



VERTIV[™]

Liebert[®] SRC

SMALL ROOM COOLING



Table of Content

Important Safety Instructions	1
1.0 Model Number and Nomenclature	4
2.0 Product Introduction	5
3.0 Installation	7
4.0 Piping	15
5.0 Electrical Connections	21
6.0 Maintenance	23
7.0 Controller	25
8.0 Hardware Details	26
9.0 Operation	27
10.0 Alarms	30
11.0 Sequencing Logic	31
12.0 Modbus Register Map	33
13.0 History Alarm	34
14.0 Trouble Shooting Guide	39
15.0 Commissioning / Preventive Maintenance Checklist	40

Important Safety Instructions

SAVE THESE INSTRUCTIONS

Do not throw away, destroy or lose this manual. Please read carefully and store in a safe place for future reference. Content familiarity required for proper installation.

The instructions included in this manual must be followed to prevent product malfunction, property damage, injury, or death to the user or other people. Incorrect operation due to ignoring any instructions will cause harm or damage.



WARNING

Risk of improper unit installation and/or removal. Can cause water and/or refrigerant leakage, electric shock, smoke, fire and explosion resulting in building and equipment damage, serious injury or death. Do not install, remove, or re-install the unit by yourself (customer). Ask the dealer or an authorized technician to install the unit. For replacement of an installed unit, always contact an authorized Liebert service provider.



WARNING

Risk of explosive discharge of high pressure gas. Can cause serious injury. The unit is shipped with pressurised gas and the service valves closed. Do not open service valves on the unit until all non-condensibles have been removed from the piping system and authorization to do so has been obtained from the commissioning agent.



WARNING

Risk of excessive refrigerant pressure. Can cause equipment damage, serious injury or death. Do not run the compressor with the service valves closed.



WARNING

Risk of contact with sharp edges, nails, splinters, and other packaging materials and improper disposal of plastic bags. Can cause injury or death. Wear gloves and arm protection when unpacking the unit and Dispose the packing materials safely.

Cut the plastic packaging bag into small pieces or dispose of securely to eliminate the risk of suffocation and death from improperly wearing the plastic bag as a head cover.



WARNING

Risk of improper installation. Can cause equipment and building damage, injury or death. Utilize a structural engineer to evaluate the mounting surface and environmental risks and recommend the safest fastening method.



WARNING

Risk of protective safety devices not operating properly. Can cause electrical short circuit, electric shock, explosion, fire, injury or death. Do not change the settings of the protection devices and only use replacement parts that are specified by Liebert.



WARNING

Risk of improper installation location. Can cause serious injury or death. Install the unit in a safe location where nobody can step on or fall onto it. Utilize a structural engineer to verify that the mounting surface and method is secure.



WARNING

Risk of electric shock. Can cause injury or death. Secure all hazardous voltage field wiring connections with appropriate wire strain relief.

Improperly secured wires will create excessive stress on electrical power connection lugs. Improper or loose connections may generate excessive heat and cause smoke and fire.



WARNING

Risk of damaged electrical components and short circuits. Can cause building and equipment damage, smoke, fire, injury and death. Do not provide power to or operate the unit if it is flooded or submerged.



WARNING

Risk of unit mounting base deterioration and collapse. Can cause building and equipment damage, injury or death. Periodically verify the equipment mounts have not deteriorated.



WARNING

Risk of electric shock and contact with high speed moving parts. Can cause serious injury or death. Do not operate the unit with the panel(s) or protective cover(s) removed; keep fingers and clothing away from moving parts. Do not open the inlet grille of the unit during operation. Do not insert hands or other objects through the inlet or outlet when the unit is plugged in. Do not touch the electrostatic filter, if the unit includes one.



WARNING

Risk of electric shock. Can cause injury or death. Periodically, check power cord and plug for damage. Damaged power cords must be replaced by the manufacturer, its service agent, or similar Liebert-trained and qualified persons.



CAUTION

Risk of exposure to refrigerant gas. Can cause injury or illness. Always check for system refrigerant leaks after the unit has been installed or serviced.



CAUTION

Risk of contact with sharp edges. Can cause injury. Wear protective gloves when handling equipment.

Important Safety Instructions



CAUTION

Risk of contact with extremely hot and cold surfaces. Can cause injury. Refrigerant piping is extremely hot or cold during unit operation. Do not touch the refrigerant piping during or after operation. Wear thermally insulated gloves and arm protection or allow the piping to cool or warm to a safe handling temperature before working on the piping.



CAUTION

Risk of improper lifting and moving of a heavy unit. Can cause building and equipment damage and injury. Be very careful when transporting the product.

- Do not attempt to carry the product without assistance. Some products use polypropylene bands for packaging. Do not use polypropylene bands to lift the unit.
- Suspend the unit from the base at specified positions.
- Support the unit a minimum of four points to avoid slippage from rigging apparatus.

Verify that all lifting apparatus is rated for the weight of the unit. See XREF TABLE for indoor and outdoor unit weights.



CAUTION

Risk of contact with sharp edges, and extremely hot or cold components. Can cause injury. Wear approved head and eye protection, thermally insulated gloves and arm protection or allow the unit to reach a safe for contact temperature and use caution when cleaning or servicing the unit.

NOTICE

Risk of exposure to corrosive environments. Can cause equipment damage. Don't install the unit where it's directly exposed to ocean winds.

Ocean winds may cause corrosion, particularly on the condenser and evaporator fins, which, in turn could cause product malfunction or inefficient performance.

NOTICE

Risk of water damage and abnormal vibration. Can cause equipment damage

When installing the unit in a low-lying area, or a location that is not level, use a raised concrete pad or concrete blocks to provide a solid, level foundation.

NOTICE

Risk of excessive condensation. Can cause building and equipment damage.

Properly insulate all cold surfaces to prevent "sweating." Cold surfaces such as uninsulated piping can generate condensate that may drip and cause a slippery floor condition and/or water damage to walls.

NOTICE

Risk of exposure to excessive Electro-Magnetic Interference. Can cause equipment malfunction.

When installing the unit in a hospital, mechanical room, or similar electromagnetic field (EMF) sensitive environment, provide sufficient protection against electrical noise.

Inverter equipment, power generators, high-frequency medical equipment, or radio communication equipment may cause the unit to operate improperly. The unit may also affect such equipment by creating electrical noise that disturbs medical treatment or image broadcasting.

1.0 Model Number and Nomenclature

Figure 1-1 Product Nomenclature

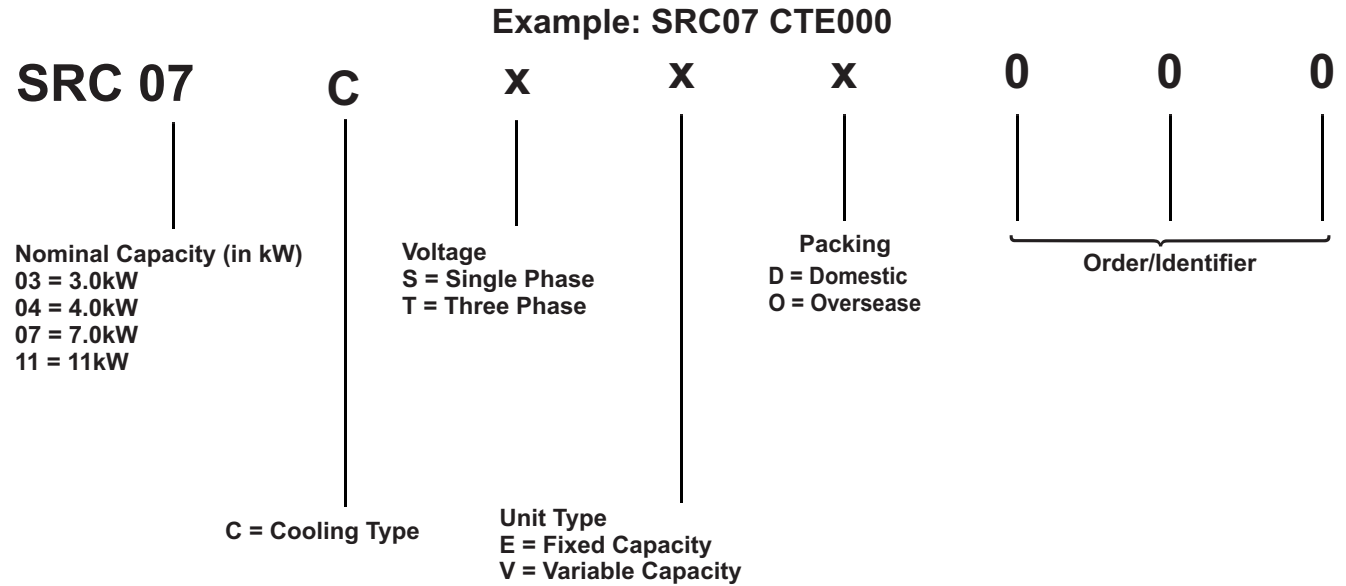

2.0 Product Introduction

Suggestions for Energy Saving when Operating the Liebert SRC:

- Do not cool excessively indoors. This may be harmful for your health and may consume more electricity.
- Block sunlight with blinds or curtains while you are operating the unit.
- Keep doors or windows closed tightly while you are operating the unit.
- Adjust the direction of the air flow vertically or horizontally to circulate indoor air.
- Speed up the fan to cool or warm indoor air quickly, within a short period of time.
- Clean the air filter once every month This cleaning intensity to very based on site condition.

Figure 2-1 Indoor Unit Parts and Functions

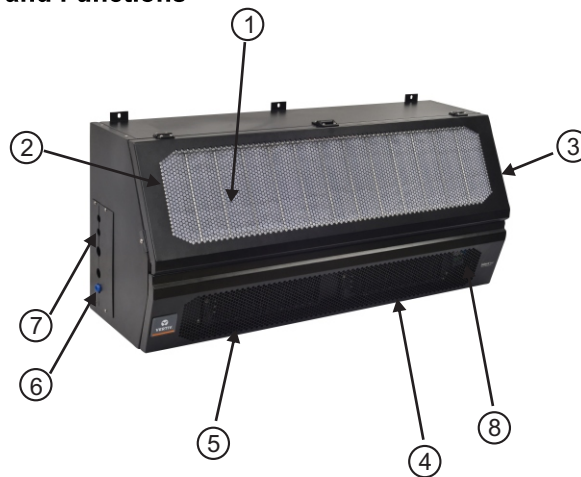

No.	Description	No.	Description
1	Air filter (under the panel)	5	Air outlet
2	Air intake	6	Drain pipe cutout
3	Front cover	7	Electrical input
4	Air deflector (vertical louver)	8	Controller location

Figure 2-2 Outdoor Unit Parts and Functions

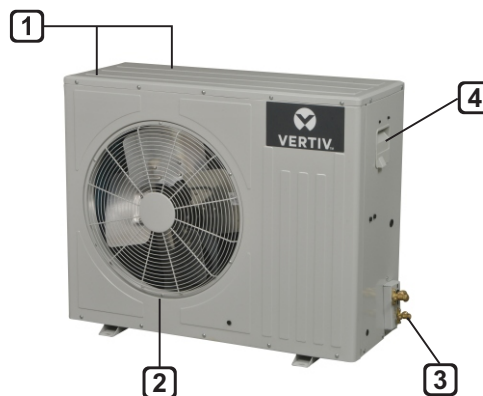

No.	Description
1	Air intake vents
2	Air outlet vents
3	Refrigeration piping
4	Electrical connection

Product Introduction

2.1 Product Technical Data

Inter Connection Pipe Specification						
Models		SCR 03	SCR 04	SCR 07	SCR 07	SCR 11
Main Power Supply Voltage		230V ± 10% 1Ph 50Hz			400V ± 10% 3Ph+N+PE / 50Hz	
Outdoor conditions	From	10°C				
	To	Upto 48°C				
Indoor conditions with compressor running	From	20°C-30°C,30% R.H. / 80% R.H.				
	To	35°C, 40% R.H.		30°C, 40% R.H.		
Storage Conditions	From	40°C, 5% R.H.				
	To	55°C, 90% R.H.				
Gas Side	Diameter (Inch)	1/2"	1/2"	5/8"	5/8"	3/4"
	Connection Type	FLARE	FLARE	FLARE	FLARE	FLARE
Liquid Side	Diameter (Inch)	3/8"	3/8"	3/8"	3/8"	1/2"
	Connection Type	FLARE	FLARE	FLARE	FLARE	FLARE
Max. Effective Length (Feet)		100	100	100	100	100
Condensate Drain Pipe	Outer Diameter (Inch)	7/8"	7/8"	7/8"	7/8"	7/8"
Maximum number of Bends		7	7	7	7	7
Electrical Connection Wire (Indoor to Outdoor)		3 Core / 2.5 Sq.mm	3 Core / 2.5 Sq.mm	3 Core / 2.5 Sq.mm	3 Core / 2.5 Sq.mm	3 Core / 2.5 Sq.mm
Refrigerant used		R410a	R407c			

3.0 Installation

3.1 Selecting the Location for the Outdoor Unit



WARNING

Risk of improper installation. Can cause serious injury or death.

- To avoid the possibility of fire, do not install the unit in an area where combustible gas may generate, flow, stagnate, or leak.
- Do not install the unit in a location where acidic solution and spray (sulfur) are often used.
- Do not use the unit in environments where oil, steam, or sulfuric gas are present.

NOTICE

Risk of unauthorized access to the unit. Can cause equipment malfunction or damage.

Install a fence to prevent vermin from crawling into the unit or unauthorized individuals from accessing it.

Select a location for installing the outdoor unit that will meet the following conditions:

- Where the unit will not be subjected to direct thermal radiation from other heat sources.
- Where operating sound from the unit will not disturb inhabitants of surrounding buildings.
- Where the unit will not be exposed to direct, strong winds.
- Where there is enough strength to bear the weight of the unit.
- Include space for drainage to ensure condensate flows properly out of the unit when it is in heating mode.
- Include enough space for air flow and for service access.
- If the outdoor unit is installed in a highly-humid environment (near an ocean, lake, etc.), ensure that the site is well-ventilated and has a lot of natural light. (For example: Install on a rooftop.)

Installation location of the outdoor unit can affect indoor-unit operation. The indoor unit may take longer to provide heat, or heating performance will be reduced in winter in the outdoor unit is installed:

- In a narrow, shady location.
- Near a location that has a lot of ground moisture.
- In a highly-humid environment.
- In an area in which condensate does not drain properly.

3.1.1 Ambient air conditions

NOTICE

Risk of exposure to improper environmental conditions. Can cause equipment damage.

- Avoid exposing the outdoor unit to steam, combustible gases, or other corrosive elements.
- Avoid exposing the unit to discharge from boiler stacks, chimneys, steam relief ports, other air-conditioning units, kitchen vents, plumbing vents, or substances that may degrade performance or cause damage to the unit.
- When installing multiple outdoor units, avoid placing the units where discharge of one outdoor unit will blow into the inlet side of an adjacent unit.

3.1.2 Oceanside Applications

Using a Windbreak to Shield the Unit from Sea Wind



NOTE

Ocean winds may cause corrosion, particularly on the condenser and evaporator fins, which, in turn could cause product malfunction or inefficient performance.

- Avoid installing the unit where it would be directly exposed to ocean winds.
- Install the outdoor unit on the side of the building opposite from direct ocean winds.
- Select a location with good drainage.
- Periodically clean dust or salt particles off of the heat exchanger with water.
- If the outdoor unit must be placed in a location where it would be subjected to direct ocean winds, install a concrete windbreak strong enough to block any winds, see **Figure 3-1** for windbreak location.
- The windbreak should be more than 150% of the outdoor unit's height. There must be 2 to 3-1/2 inches of clearance between the outdoor unit and the windbreak for purposes of flow.

Figure 3-1 Oceanside placement using a windbreak

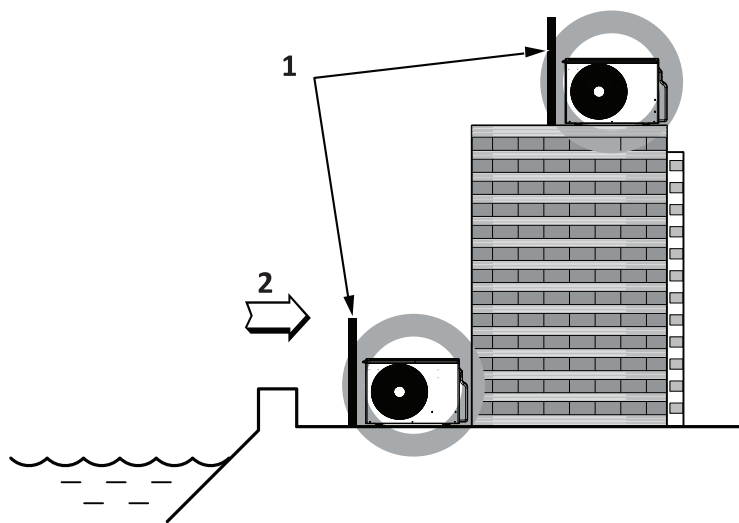

No.	Description
1	Windbreak
2	Sea wind

Installation

Using a Building to Shield the Unit from Sea Wind

If a windbreak is not possible, a building or larger structure must be used to shield the outdoor unit from direct exposure to the sea wind. The unit should be placed on the side of the building directly opposite to the direction of the wind as shown in **Figure 3-2**.

Figure 3-2 Oceanside placement using a building

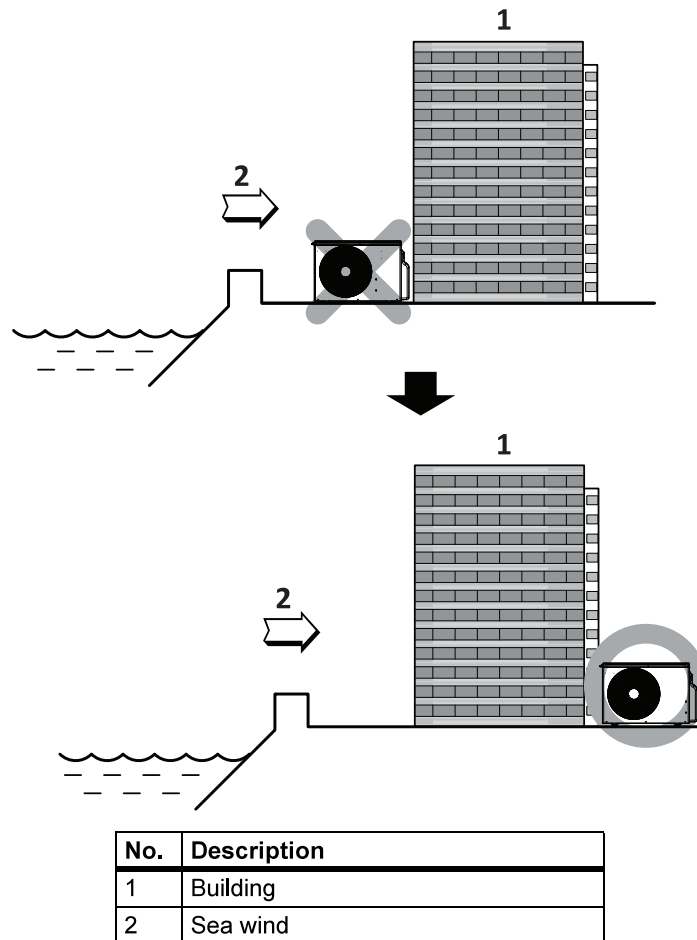

3.2 Mounting the Outdoor Unit

Securely attach the outdoor unit to a condenser pad, base rails, or another mounting platform that is securely anchored to the ground or building structure. Attach the outdoor unit with a bolt and nut on a concrete or rigid mount. See **Figure 3-3**. Follow applicable local codes for clearance, mounting, anchor and vibrations attenuation requirements.



NOTE

All referenced materials are field-supplied. Images are not to scale.

Figure 3-3 Outdoor unit mounting methods



1	Dimension(mm)	(L)1050 X (W)444 X (H)802
2	Weight	72kg

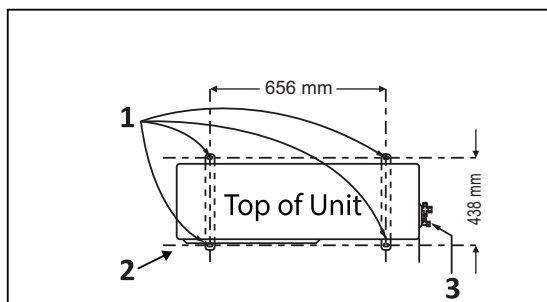

No.	Description	No.	Description
1	Bolt placement and Anti-vibration pad	3	Piping connection
2	Foundation		

3.2.1 Mounting Platform

The underlying structure or foundation must be designed to support the weight of the unit. Avoid placing the unit in a low-lying area where water may accumulate. When installing the outdoor unit on the wall or roof top, anchor the mounting base securely to account for wind, earthquake or vibration.

3.2.2 Tie-downs and Wind Restraints

The strength of the inverter system frame is adequate to be used with field-provided wind restraint tie-downs. The overall tie-down configuration must be approved by a local, professional engineer.



NOTE

Always refer to local code when designing a wind-restraint system.

Installation

3.3 Clearance requirements

Proper airflow through the outdoor unit coil is critical for correct unit operation. When installing, consider service, inlet and outlet, and minimum allowable space requirements as illustrated in **Figure 3-4**.

3.3.1 Outdoor Unit Clearance

Specific clearance requirements are for the wall-mount systems. **Figure 3-4** shows the overall minimum clearances that must be observed for safe operation and adequate airflow around the outdoor unit.

Figure 3-4 Outdoor-unit clearances

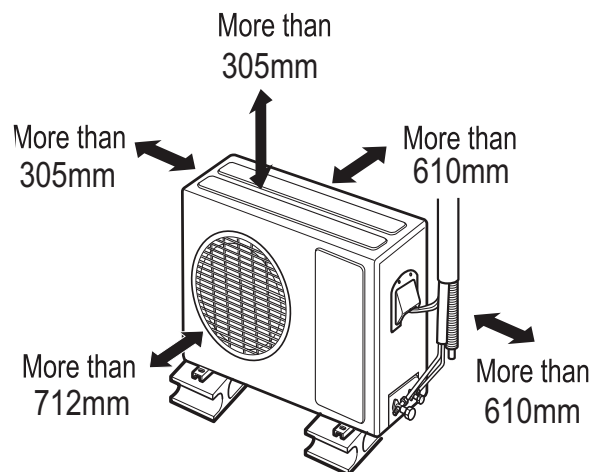

When placing the outdoor unit under an overhang, awning, sunroof or other “roof-like” structure, observe the clearance requirements (as shown in **Figure 3-5**) for height in relation to the unit. This clearance ensures that heat radiation from the condenser is not restricted around the unit. See **Figures 3-6** and **3-7** for recommendations when other obstacles are present.

Adhere to all clearance requirements if installing the unit on a roof. Be sure to level the unit and ensure that the unit is adequately anchored. Consult local codes for roof-top mounting requirements.



NOTE

Do not place the unit where animals and/or plants will be in the path of the warm air, or where the warm air and/or noise will disturb neighbors.

Figure 3-5 Outdoor-unit sunroof/awning clearances

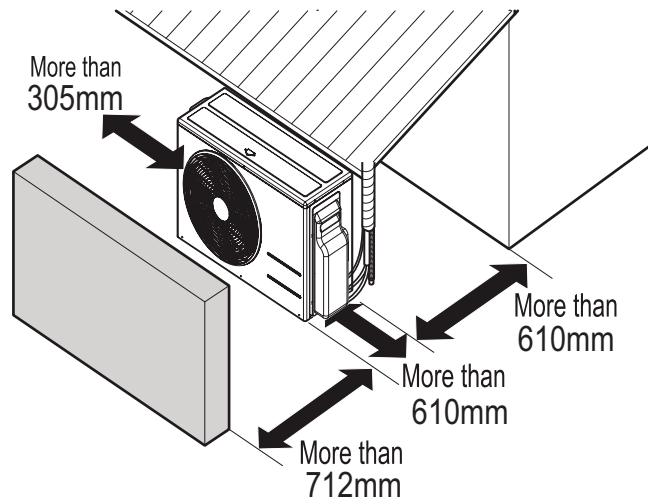
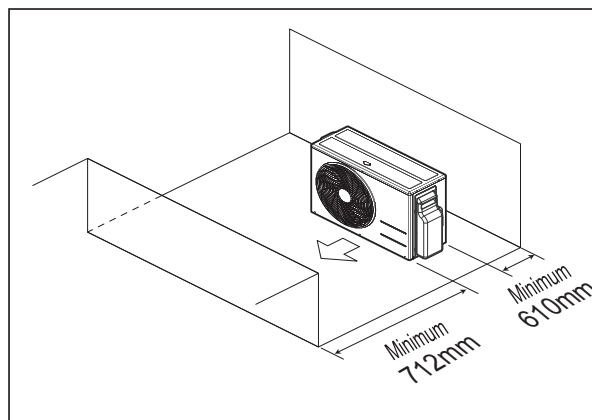

Figure 3-6 Clearances when there are obstacles on both air-inlet and air-outlet sides



NOTE

In Figures 3-6 and 3-7, the obstacle on the outlet side is lower than the outdoor unit.

Figure 3-7 Clearances when there are obstacles above and on both air-inlet and air-outlet sides

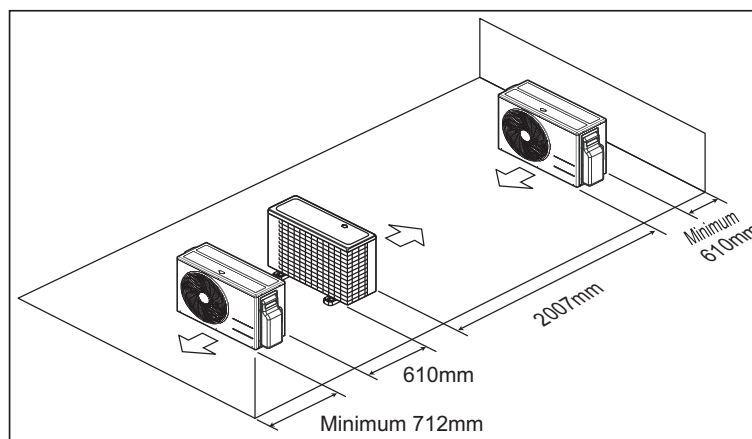

Installation

3.3.2 Indoor Unit Clearance

Follow recommended practices when choosing an indoor location for the wall-mounted indoor unit.

- Keep unit away from any indoor steam or excessive heat.
- No obstacles should be placed around the unit.
- Condensation drain (leakage piping) should be routed away from the unit.
- Do not install near a doorway.
- Clearance gap between any wall or enclosure and the left or right side of the unit must be greater than 4 inches, **Figure 3-8**.
- From the top of the unit to the ceiling, there must be greater 8 inches of clearance, see **Figure 3-8**.
- Unit should be at least 6.5 feet from the floor for adequate clearance.

Figure 3-8 Indoor unit clearance requirements

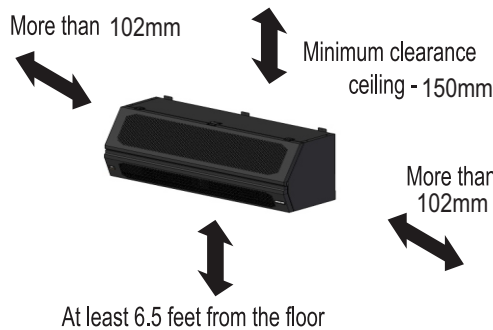

1	Dimension(mm)	(L)1105 X (W)375 X (H)512
2	Weight	62kg

3.4 Installing the Indoor Unit

1. LOCATE BOTTOM CHANNEL (ITEM01) ON WALL.
2. MARK HOLE POSITION, M8 CSK SCREWS 4NO'S .
3. DRILL AND MOUNT THE CHANNEL ON WALL.
4. PICK-UP INDOOR UNIT AND LOCK ON THE MACHINE LOCKING FLANGE.
5. MARK THE HOLE POSITION M6 SCREW 3NO'S.
6. TIGHTEN THE SCREW.
7. PROCEED FOR PIPING AND WIRING ROUNTING .

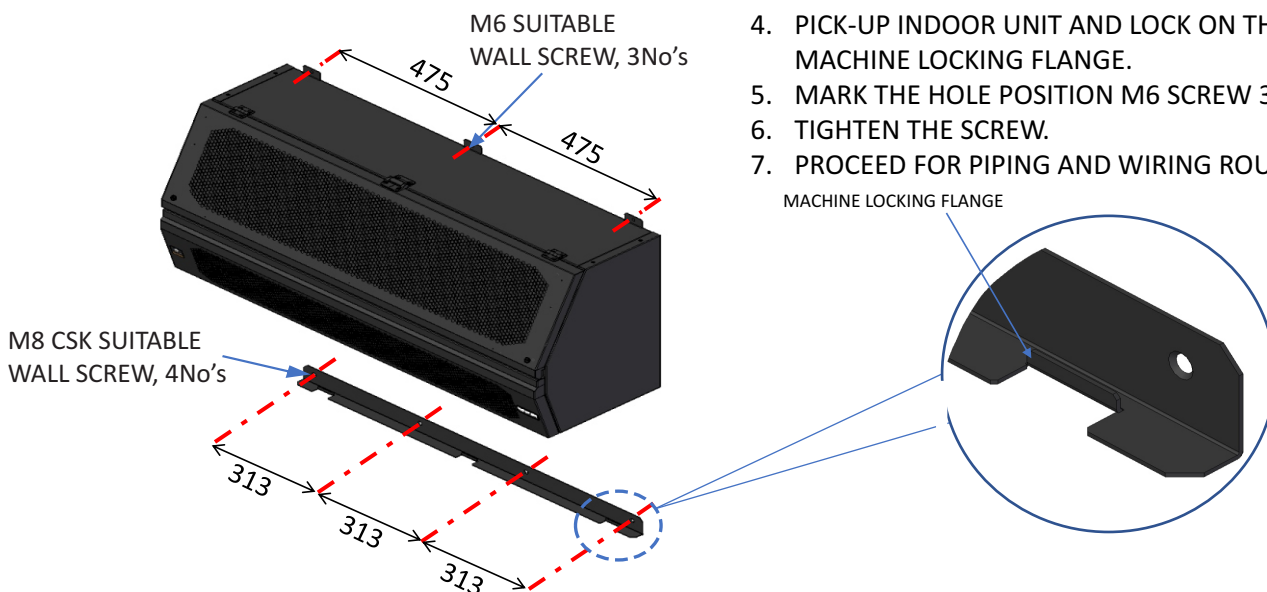

3.4.1 Mounting the Installation Plate to the Wall



WARNING

Risk of electrical shock. Can cause injury or death.

- When choosing a location for the wall-mount plate, be sure to take into consideration routing of wiring for power outlets within the wall. Avoid contact with hazardous voltage wiring.
- Use caution when drilling holes through the walls for the purposes of piping connections.

Refer to **3.4.3 - Drilling a Piping Hole in the Wall**, as you following the plate-installation procedure.



WARNING

Risk of improper mounting. Can cause building and equipment damage, serious injury or death.

Consult a structural engineer to determine the suitability of the wall for mounting and the recommended fastening method. Unit must be anchored tightly to a wall having sufficient strength to support the unit during operation to prevent the unit from falling or creating excessive, unnecessary vibration during operation.

Follow this procedure and best practices when mounting the indoor unit's plate to a wall.

3.4.2 Drilling a Piping Hole in the Wall

Follow the left or right piping-clearance recommendations.

1. Using a 2-5/8 in. (0.65 mm) hole-core drill bits, drill a hole at either the right or left side of the wall mounting, **Figure 3-13**.
 - The slant of the hole should be 3/16 to 5/16 of an inch from level with an upward slant on the indoor-unit side and downward on the outdoor-unit side.
2. Finish-off the newly-drilled hole as shown in **Figure 3-13** with a bushing and sleeve covering.
 - The sleeve and bushing prevents damage to the tubing/bundling of the piping.

Figure 3-13 Drilling a piping hole

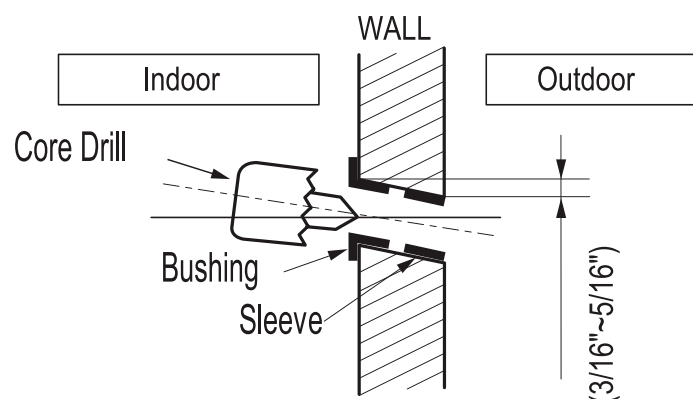

4.0 Piping

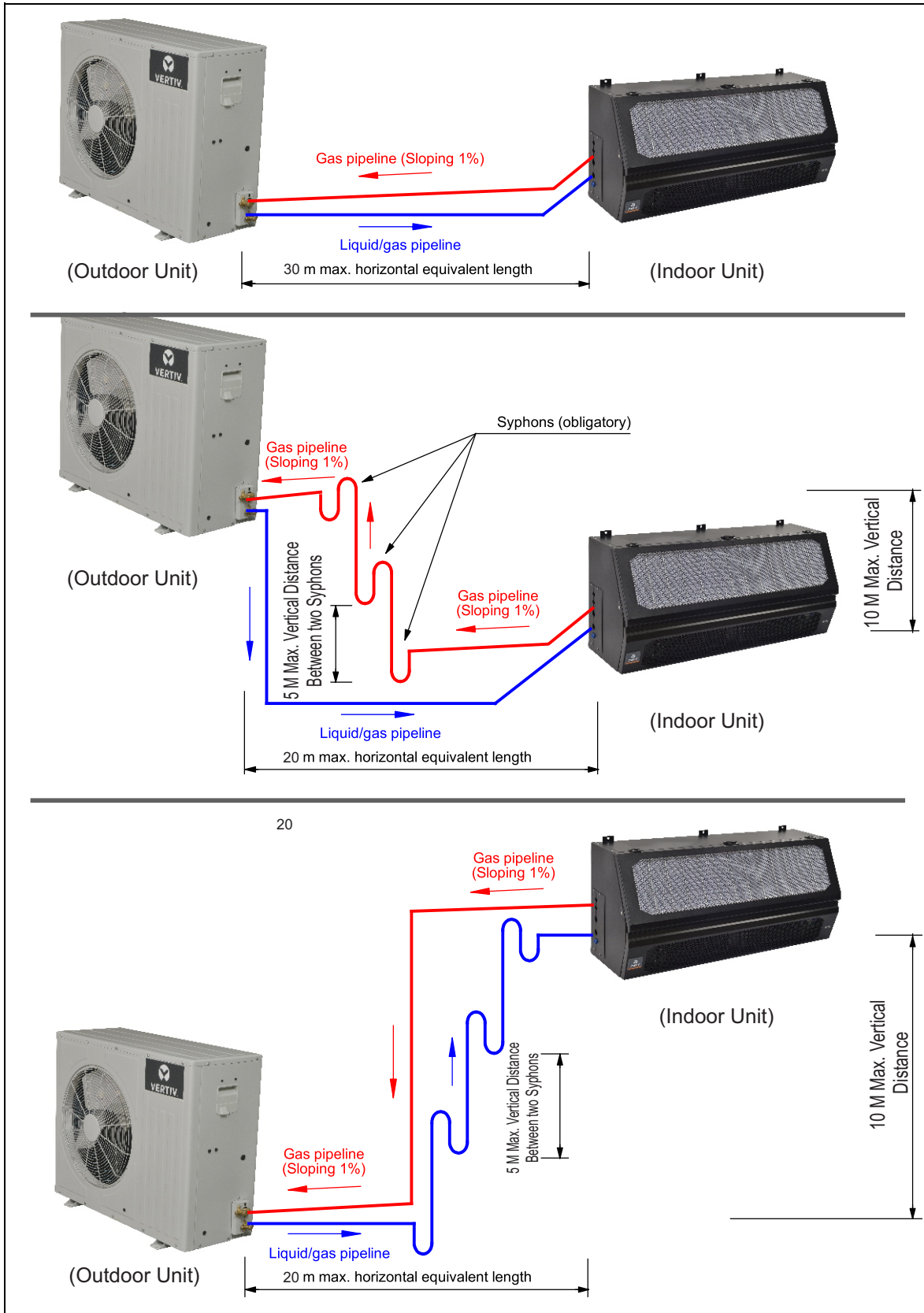

4.1.1 Pipe bundling

Refer to **Figure 4-15** for proper cable and pipe bundling. Note the placement of the piping along with the necessary insulation material.

Figure 4-15 Proper pipe and cable bundling—cut-away

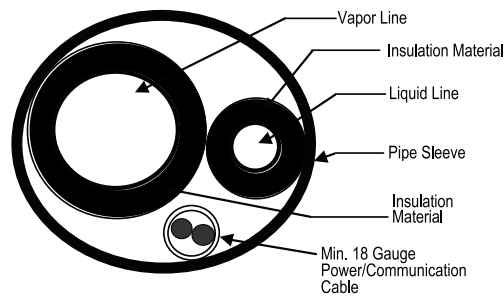

1. Be sure to wrap each pipe with proper insulation material.
2. Secure the piping by wrapping vinyl tape around the pipe.
 - Use narrow-size tape for wrapping the actual pipe.
3. You can include the drain hose in the bundled piping and wrap all of them together using wider vinyl tape.
 - The end of the drain-hose outlet must be routed above the ground.

4.1.2 Connecting Piping on the SRC Outdoor Unit

1. Remove the tubing cover by loosening the fastening screws,



NOTE

Do not thread liquid or gas piping through bracket used to hold main power cables.

2. Align the center of the refrigerant pipe and corresponding connection as shown in **Figure 5-24**.

Figure 5-24 Align center of piping connection

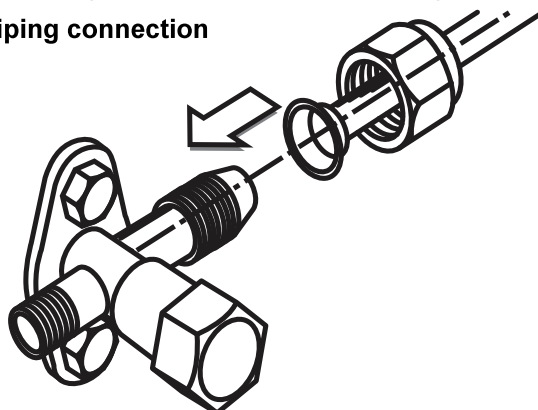

3. Refer to **Figure 5-25** for correct liquid and gas pipe attachment to the outdoor unit.
4. Place a couple of drops of refrigerant oil on the opening rim of the flare before assembling, making sure that you do not introduce any contaminants, and tighten the flare nut by hand.
5. Following the torque guidelines in **Figure 5-14**, finish tightening the flare nut with a torque wrench until the wrench clicks referring to **Table 5-25** for correct connection points.



NOTE

When tightening the flare nut with a torque wrench, make sure the direction for tightening follows the arrow on the wrench.

Table 5-14 Tightening torque for flare nuts

Pipe size (in. O.D.)	Tightening torque (ft-lbs)
1/4	13.9 – 18
3/8	24.5 – 30.3
1/2	39.7 – 47.7
5/8	45.5 – 59.2
3/4	71.6 – 87.5

Figure 5-25 Correct piping attachment for SRC outdoor unit

7. Make sure the tube cutting line is placed upward, **Figure 5-32**.

Figure 5-32 Correct cutting line placement

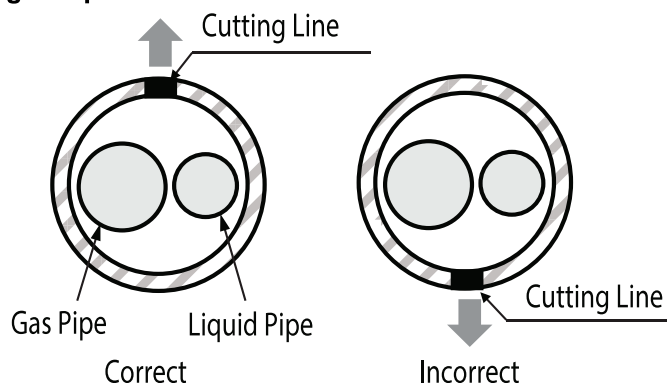

Piping

8. Use narrow type vinyl tape, and make sure that the section placed in the rear pipe housing is wrapped sufficiently.
9. Continue to wrap the indoor-unit pipe connection to the outdoor-unit as shown in **Figure 5-33**.

4.2 Piping Insulation

To prevent heat loss/heat gain through the refrigerant piping, all refrigerant piping, including liquid lines and vapor lines, must be insulated separately. Insulation must be a minimum 1/2-in. thick, and the thickness may need to be increased based on ambient conditions and local codes. All refrigerant piping, including field-supplied isolation ball valves, service valves, and elbows must be completely insulated using closed-cell pipe insulation. All insulation joints must be glued with no air gaps. Insulation material must fit snugly against the refrigeration pipe with now space between it and the pipe. Insulation passing through pipe hangers, inside conduit, and/or sleeves must not be compressed. Protect insulation inside hangers and supports with a second layer.

Figure 5-36 Typical pipe-insulation, power wire, and communications-cable arrangement

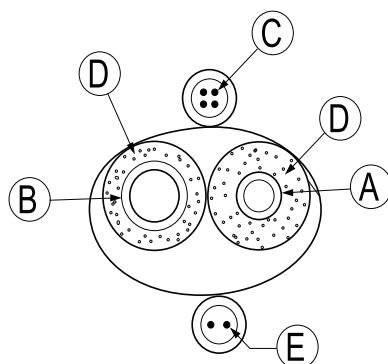

- A Liquid Pipe
- B Gas Pipe
- C Power Wiring
- D Insulation
- E Communication Cables

Figure 5-37 Typical butt-joint insulation at indoor unit

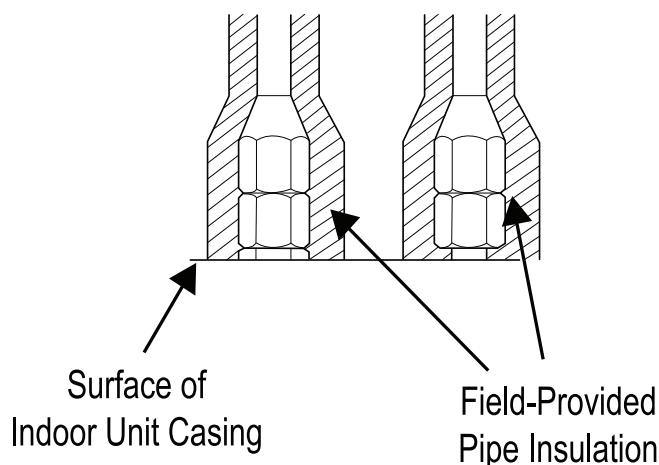
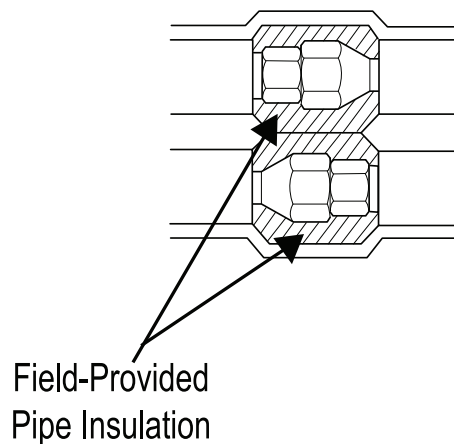

Figure 5-38 Typical refrigerant flare-fitting insulation



4.2.1 Piping Leak Test

Perform the leak test by pressurizing nitrogen gas to 550 psi on both the liquid and gas pipes. Test with the piping service valves closed. If the pressure does not drop for 24 hours, the system passes the test. If the pressure drops, there is a nitrogen leak in the system. Find the leak, repair it, and test again.



WARNING

Risk of using combustible gases. Can cause explosion and fire resulting in building and equipment damage, serious injury or death.

Do not use combustible gases, including oxygen for leak detection. Use only inert gas (nitrogen) when checking plumbing leaks, cleaning or repairing pipes, etc.

4.2.1.1 Connecting the pressure gauge



NOTE

- To avoid nitrogen entering the refrigerant system in a liquid state, the top of the cylinder must be higher than its bottom when you pressurize the system.
 - Be sure the cylinder is used in a vertical standing position.
1. Connect the manifold valve (which includes the pressure gauges) and the dry-nitrogen gas cylinder to the service valves using a charge hose.
 2. Pressurize the system to maximum 550 psig with dry-nitrogen gas and close the cylinder valve when the gauge reaches 550 psig.

4.2.1.2 Soap-and-Water Leak Testing

1. Remove the caps from the 2-way and 3-way valves.
2. Open the 2-way valve by turning the valve stem counter-clockwise approximately 90 degrees, wait for 2 to 3 seconds, and close it.
3. While running nitrogen pressure, apply a soapy-water or liquid, neutral detergent on the indoor or outdoor unit connections using a soft brush, and observe the connections for any leaks.
 - Bubbles at connection points or joints indicate a leak.
4. Make a note of any leaks along the liquid and gas piping.
5. Disengage the nitrogen pressure by loosening the charge hose at the cylinder.
6. When pressure returns to normal, disconnect the charge hose from the cylinder.
7. Make repairs to all connections and piping where leaks were observed.
8. When repairs are complete, repeat the leak test using nitrogen pressure and check for further leaks.
9. Once the piping system is leak-free, proceed.

4.2.1.3 Ambient Temperature for Leak Test

If the ambient temperature changed between the time when the pressure was applied and when the pressure-drop was checked, adjust the results by factoring-in approximately 1.45 psi for each 2°F of temperature difference.

Correction formula = (Ambient temperature when pressure was applied – Ambient temperature when pressure drop was checked) x 0.01.

For example:

When pressure (550 psig) was applied, the ambient temperature was 80.6°F. When the pressure drop was checked 24 hours later (540 psi), the ambient temperature was 68°F.

Therefore, $80.6 - 68 \times 0.01 = 0.126$. In this case, the pressure drop of 0.126 was due to temperature difference, and there is no leak in the refrigerant-piping system.

4.2.2 Evacuation

After successfully completing leak testing, use the same hook-up described to perform the evacuation procedure.



NOTE

- Be sure to use a manifold valve for air purging. If it is not available, use a stop valve.
- Be sure that the knob of the 3-way valve is always kept closed.

1. Confirm that the “Lo” knob of the manifold valve is open.
2. Confirm that the “Hi” knob of the manifold valve is closed.
3. Run the vacuum pump until the system is evacuated down to 300 microns, and continue to run the pump an additional 15 minutes.



NOTE

The duration of running the vacuum pump will vary according to pipe length and pump capacity. Refer to **Table 5-17** for accurate time duration.

Table 5-17 Evacuation timing*

Tubing less than 33 ft.	Tubing more than 33 ft.
10 minutes or more	15 minutes or more

* Required time for evacuation when 30-gal/h vacuum pump is used.

4. When appropriate time has elapsed, turn-off the pump and leave the connections secured on the service valves for 5 minutes.
5. If the system fails to hold 500 microns or less, check all connections for a tight fit and repeat the evacuation steps.
6. When the correct vacuum is reached, close the “Lo” knob of the manifold valve and stop the vacuum pump.

4.2.3 Removing Purge and Test Equipment

When evacuation is completed, turn-off all valves at the outdoor unit and safely disengage the manifold valve and vacuum pump using the following steps.

1. Using a wrench, turn the valve of the liquid stem counter-clockwise to fully open the valve.
2. Turn the valve of the gas temp counter-clockwise to fully open the valve.
3. Loosen the charge hose connected to the gas-side service port slightly to release the pressure, and remove the hose.
4. Replace the flare nut and its cap on the gas service port, and fasten the flare nut securely using an adjustable wrench.
 - This step is very important to prevent leakage from the system.
5. Replace the valve caps at both gas- and liquid-side service valves and fasten them tightly.

5.0 Electrical Connections



WARNING

Arc flash and electric shock hazard. Can cause serious injury or death. Open all local and remote electric power disconnect switches, verify with a voltmeter that power is off and wear personal protective equipment before working within the electric control enclosure.



WARNING

Risk of electric shock and overheated wiring. Can cause injury or death. All field-supplied power wiring, overcurrent protection (circuit breakers/fuses) and earth grounding must be installed by a trained and qualified HVAC technician in accordance with local, state, and National Electrical Code regulations related to electrical equipment and wiring.

- Read and follow explicitly all instructions and safety alert messages in this manual.
- Do not connect ground wire to refrigerant, gas or water piping, to lightning rods, to telephone ground wiring, or to the building plumbing system.
- Replace and securely fasten all control box and panel covers immediately after working on the unit to protect the operator from the hazards above.

NOTICE

Risk of electrical phase reversal. Can cause equipment damage, unit malfunction and loss of cooling operation.

If there is a possibility of reversed phase, phase loss, momentary blackout, or the power goes on and off while the system is operating, install a field-supplied phase-loss protection circuit.



NOTE

Consider ambient conditions (temperature, direct sunlight, inclement weather, etc.) when selecting, installing, and connecting the power wiring.

5.1 Power-supply/Power-wiring Specifications

- Liebert SRC systems operate at 230V ± 10% 1Ph 50Hz, 400V ± 10% 3Ph+N+PE / 50Hz
- Power-supply wire type and size should be selected based on National Electrical Code and local codes. Maximum allowable voltage fluctuation ±10% or nameplate rated value. Refer for wiring guidelines.
- Properly ground the indoor and outdoor unit per National Electrical Code and local codes.
- Use only copper wiring that is stranded and shielded with the wires separately insulated.
- Ground wire should be longer than the common power/communication wires.
- Refer to the appropriate circuit and terminal-block diagrams for your model unit.
- Always match color codes of each wire and follow wiring diagram.

If ring terminals or space clips are not available then:



WARNING

Risk of improper electrical connection termination. Can cause building and equipment damage, excessive heat at the terminations, smoke, fire, electric shock, serious injury and death.

Do not terminate different gauge wires to the power terminal block. Slack in the wiring may generate heat and fire. Do not ground the shield of the communications cable to the indoor unit frame or other grounded entities of the building.

Electrical Connections



NOTE

- *When terminating wires of the same thickness, follow the instructions.*
- *Attach the wire securely without placing external force on the terminal block.*
- *Use an appropriately-sized screwdriver to tighten the terminals.*
- *Do not over-tighten the connections. Over-tightening may damage the terminals.*
- *Never apply line-voltage power to the communications-cable terminal block. If contact is made, the PCBs may be damaged.*
- *Always include some allowance in the wiring length when terminating. Provide some slack to facilitate removal of electrical panels when servicing.*

Figure 6-3 Proper and Improper power-wiring connections

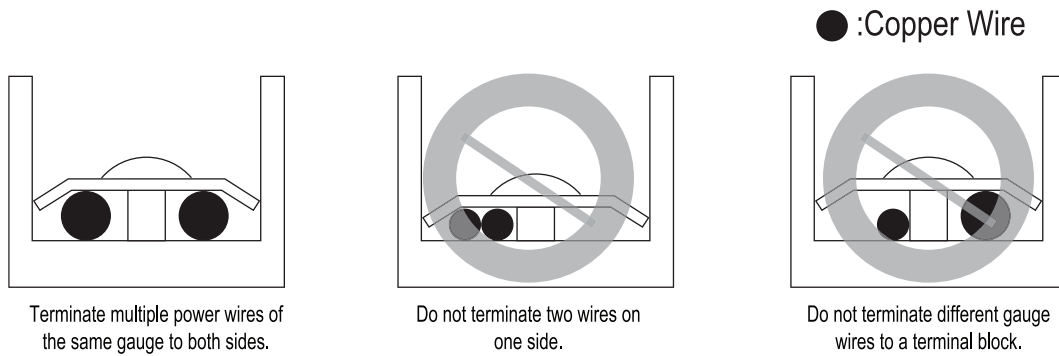

6.0 Maintenance



WARNING

Arc flash and electric shock hazard. Can cause serious injury or death. Open all local and remote electric power disconnect switches, verify with a voltmeter that power is off and wear personal protective equipment before working within the electric control enclosure.

If the unit will not be used for an extended period of time, dry the unit to maintain it in the best condition. Clean the unit regularly to maintain optimal performance and to prevent possible breakdown.

- Dry the unit in Fan mode for 3 to 4 hours and disconnect the power. There may be internal damage if moisture is left in unit's components.
- Before using the unit again, dry the unit in Fan mode for 3 to 4 hours to remove odor generated by moisture.

Figure 9-1 Cleaning the outside of the indoor unit



NOTICE

Risk of improper cleaning. Can cause cabinet finish damage.

- Never use water that is higher than 104° (40°C) when you clean the filters. It may cause deformation or discoloration.
- Never use volatile substances when you clean the filters. These may damage the surface of the unit.

Table 9-1 Cleaning Schedule

Component	Description	Interval
Air filter	Clean with a vacuum or hand wash.	1 month
Indoor unit	Clean the surface using a soft, dry cloth.	Regularly
	Have a professional clean the condensate drain pan.	Once a year
	Have a professional clean the condensate drain pipe.	Every 4 months
Outdoor unit	Have a professional clean the heat-exchanger coils and the panel vents. (Consult a technician.)	Once a year
	Have a professional clean the fan.	Once a year
	Have a professional clean the condensate drain pan	Once a year
	Have a professional verify that the fan assembly is firmly tightened.	Once a year
	Clean the electric components with air.	Once a year

9.1 Cleaning the Air Filter

Clean the air filter once every month or more if necessary.



NOTE

- *Bending the air filter can break it.*
- *If the air filter is not assembled correctly, dust and other substances can enter the indoor unit.*

9.1.1 Cleaning the Air Filter

1. Turn-off power and unplug the power cord.
2. Open the front cover by lifting both sides of the cover slightly.

Figure 9-2 Removing the air filter unit

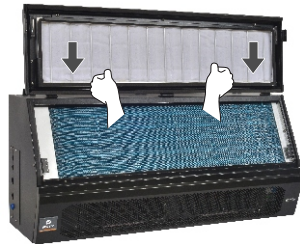

4. Clean the filters with a vacuum cleaner or lukewarm water with a neutral detergent.
5. Dry the filters in the shade.
6. Insert the hooks of the air filters into the front cover, , and make sure the filters are inside the cover for correct assembly.

Figure 9-3 Inserting cleaned air filter in Type 1 unit

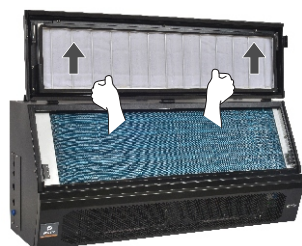

Controller

7. Scope

7.1 Definition of Terms :

Sr. No.	Abbreviation	Description
1.	E-Fan	Evaporator Fan
2.	C-Fan	Condensation Fan
3.	PWM	Pulse Width Modulation
4.	PFC	Potential Free Contact
5.	RPM	Revolution per minute
6.	RTC	Real time Clock
7.	CAN	Controller Area Network
8.	HP	High Pressure
9.	LP	Low Pressure
10.	SRC	Small Room Cooling

8. Hardware Details

Hardware of SRC controller consists of 32-bit ARM cortex M controller (STM32F302xC) as a Microcontroller. Controller Main Interfaces are

- ❖ ADC measurements
 1. Temperature probes – 7 NTC Probes
 2. Pressure Probes – 3 (Either 0-5V or 4-20 mA)
 3. AC voltage (24V AC)
 4. AC current
 5. 4-20 mA Sensors - 2
- ❖ Three RS485 channels – Display, Compressor, User Interface
- ❖ EEV Drive – Stepper Motor Drive
- ❖ CAN Communication for Inter-SRC communication
- ❖ RTC Interface
- ❖ 3 SPEED Interface for FAN control
- ❖ 3 Capture Interfaces
- ❖ Isolated and Non Isolated Digital Inputs
- ❖ Relay/PFC – 1 Compressor Relay, 3 FAN Relays, 5- Alarm Relays
- ❖ EEPROM for Configuration saving
- ❖ Flash for Data Saving
- ❖ I2C interface for Humidity Sensor.
- ❖ Optional Display and Keypad Interface (8 pin display and 4 keys)

8.1 Hardware used in SRC

1. Temperature Probes: Supply, Return, Ambient
2. SPEED and capture: 2 number for evaporator fans
3. EEPROM and Flash: For Event and configuration storage
4. RS485 : Display and User Interface
5. Digital Inputs: HP, LP, Bad Power, Fire, Compressor Contactor fail.
6. RTC
7. PFC: Compressor, Evaporator Fan – 2 number, 2 for user (1 for alarm, 1 for controller ON Status)

8.2 Operating the unit

1. Use the ON/OFF button on corded remote to operate the system.
2. Press ON/OFF button.



9. Operation

This section describes operation of Air condition system for SRC only. For SRC there are two evaporator Fans of variable speed type with tachometer output for feedback. There is a condensate fan which is of fixed speed and is turned on/off through compressor relay.

9.1 Power on Sequence:

After Power on, all peripherals are initialized and complete system is made OFF.

1. Compressor and condensate fan relay is turned off.
2. Alarm and Application will be handled after 5 seconds.
3. There are two evaporator fans, so evaporator fan relays are turned on.
4. Run Evaporator FAN at fixed speed for a fixed time as configured. (Default 40% SPEED and for 15 seconds).
5. Compressor will be off for the configured time. (Default 30 seconds)
6. Indoor temperature is taken from supply temperature or return temperature as per configuration. (Default Return temperature)

9.2 Modes of Operation

Machine can worked in following modes; some of the modes are enabled only if they are enabled in configuration.

1. Cooling Not Required (Idle): Temperature is within range
2. Cooling Not Possible: HP, LP, of fan fail alarms are present and temperature is above setpoint + differential.
3. Compressor Cooling: Compressor will be used for cooling.
4. Fault Mode: If any of the critical alarm as bad power, fire, HP,LP
5. REMOTE OFF: Unit will be in off condition on pressing off key from display.

9.3 Mode selection

After power on time, appropriate mode will be selected. Sequence of operation is as below.

Default mode is Cooling Not Required.

1. If any of the alarm is active among fire, bad power, fan fail, mode of operation will be fault mode
2. Mode of operation will be selected as per current running mode.

9.3.1 Cooling Not Required or Cooling Not Possible:

1. If Indoor Temperature \geq (Cooling Setpoint + Cooling Diff) then
 - 1.1. If HP, LP and compressor fault alarms are not present and compressor OFF time is elapsed then mode of operation will be Compressor cooling mode.
 - 1.2. Else mode will be Cooling Not Possible.
2. Else mode will be Cooling Not Required (Idle).

9.3.2 Compressor Mode:

1. If any of the HP, LP and compressor fault alarms is present then mode of operation will be Cooling Not Required. (Idle) or Cooling Not Possible.
2. Else if minimum run time of compressor is not elapsed then mode of operation is compressor.
3. Else if $((\text{Setpoint} - \text{Hysteresis}) < \text{Indoor Temperature})$ the mode of operation will be Cooling Not Required. (Idle)

9.3.3 Fault Mode:

1. If Fire or AC Bad or Fan fail alarms are present then mode of operation will be Fault mode
2. Else Mode of operation will be Cooling Not Required.

9.3.4 Remote OFF Mode:

Till user provides remote ON command through display or Modbus, mode of operation remains Remote OFF. Else it will be Cooling Not Required.

9.4 Mode Change

When Mode is changed from previous mode of operation then operations are performed depending on the new mode selected.

9.4.1 Compressor Mode

This mode will be selected only from Cooling Not Required or Cooling Not possible mode. So sequences of operation performed are

1. Condensate fan and Evaporator fan is run at the fixed speed for the time configured.
2. Compressor and condensate fan relay is turned ON
3. Evaporator fans relay is operated.
4. Condensate fan and Evaporator fans are run at the fixed speed for the time configured.
5. HP, LP alarms delay timer is loaded
6. Compressor Minimum run time timer is loaded.

9.4.2 Fault Mode or Remote OFF mode

1. All fans and compressor relays will be turned off
2. Compressor Minimum off time timer will be loaded.

9.4.3 Cooling Not Possible or Cooling Not Required Mode

1. Condensate fan relay will be turned off
2. Compressor relay will be turned off and compressor minimum off time timer is loaded.
3. Evaporator fans are run fixed speed and configured time is loaded in timer.

9.5 Same Mode Operation:

In Cooling Not required or Cooling Not Possible only Evaporator fan is managed as per configuration while condensate fan is kept OFF. (Default: 40% to 90% for 20C + 5C)

In compressor mode both condensate and evaporator fans are Fixed speed in SRC.

9.5.1 General Fan Operation

Speed of the fan (SPEED required) will be determined from the values configured by Line Equation Y
 $= mX + C$ where

$$m = (\text{Max SPEED} - \text{Min SPEED}) / (\text{Full Speed} - \text{Start Speed})$$

$$C = \text{Max SPEED} - (m * \text{Full Speed})$$

$$\text{Fan SPEED required} = m * \text{Sensor Temperature} + C$$

Fan Speed will be corrected after configured Fan Correction time (Default 30 Seconds)

9.5.2 Evaporator Fan Operation

If Evaporator Fan is configured as variable speed then Evaporator Fan SPEED will be adjusted as per indoor temperature as mentioned above.

As per configuration of Evaporator fan control method (P or PID) SPEED will be changed.

In case of Compressor mode If PID Method is configured then following algorithm is used.

1. If Indoor temperature is more or less than 0.5 degree Celsius of setpoint then only PID loop algorithm is used.
2. If (Setpoint > Indoor Temperature) then
 - 2.1. If new calculated SPEED as per configuration is less than previously provided SPEED then update new SPEED with previous SPEED.
 - 2.2. If (Set point – Indoor Temperature) is less than -0.5 then new calculated SPEED is added by offset of $(\text{Max SPEED} - \text{Min SPEED}) / 20$
3. Else If (Setpoint < Indoor Temperature) then
 - 3.1. If new calculated SPEED as per configuration is greater than previously provided SPEED then update new SPEED with previous SPEED.
 - 3.2. If (Set point – Indoor Temperature) is greater than +0.5 then new calculated SPEED is subtracted by offset of $(\text{Max SPEED} - \text{Min SPEED}) / 20$
4. Newly calculated SPEED should be between Minimum and Maximum SPEED, if greater then Max then truncate to Max if less than Min truncate to Min.

Evaporator Fan SPEED change is carried out every 30 seconds.

9.5.3 Condenser Fan Operation

Condensate Fan and compressor share the same relay for turning ON/OFF. Also it is fixed speed fan hence it will be turned on in compressor mode only.

10. Alarms

10.1 LP Alarm: Low Pressure Alarm

LP switch will provide PFC output to Control board. This alarm will be generated only after 15 seconds of compressor ON and in running condition if active. This alarm is auto resettable if configured. (Default Auto resettable)

10.2 HP Alarm: High Pressure Alarm

HP switch will provide PFC output to Control board. This alarm will be generated if active independent of compressor is running. This alarm is auto resettable if configured. (Default: Not Auto resettable)

10.3 Fire Alarm:

This alarm is non auto resettable alarm generated based on digital input.

10.4 AC BAD:

This alarm is auto resettable alarm generated based on digital input or measurement in case of single phase as per configuration. (Default: Digital Input)

10.5 HT: High temperature

This alarm is auto resettable alarm generated if Cooling temperature is greater than configured value. (Default: 35.0C)



10.6 Temperature Sensor Fail

This alarm is auto resettable alarm generated if temperature sensor fails. In this case fan will run at full speed.

11. Sequencing Logic

When there are more than 1 system connected to cool same environment this feature comes in picture. In this mode of operation all units will communicate with each other on CAN bus. Unit having machine ID 1 will be considered as master and its probes are used (Unless temperature probes are failed).

Sequencing is performed in following conditions

-  Cascading: Sequencing in N + 1 Mode
-  Sequencing on Time based. (8 hrs, 12 hrs , 24 hrs etc)
-  Sequencing on fault failure.

11.1 Cascading:

This will work to provide more cooling in case of one machine is not sufficient to perform cooling.

For example:

If Set point is 20C, differential is 6C and number of units are 3 then

1. Unit number ONE will ON above 22C and OFF below 20C.
2. Unit number TWO will ON above 24C and OFF below 22C.
3. Unit number THREE will ON above 26C and OFF below 24C.

11.2 Time Based

This will work to provide equal usage of machines. Maximum run time in minutes is configurable (Default: 8 Hrs). Unit which is having lowest compressor run hours will highest priority i.e. unit number one.

11.3 Fault:

If one of the unit gets faulty then the unit which is healthy and have lower priority (by run hours) than fault unit will gets its priority.

11.4 Sequencing Example:

- ❖ Lowest machine ID is considered as Master and its temperature probes are used for deciding logic till it has all temperature probes OK.
- ❖ Logical ID is calculated as per sequencing logic. (Run Hours and fault)
- ❖ Logical ID 0 is highest priority. i.e. lowest differential
- ❖ Cooling point is calculated for each unit as Set point + (Difference / Number of units) * logical ID
- ❖ Logical ID will be rotated if one of the following conditions meets
 - a) If run hours of any of the running unit reaches Max run Hours

- b) If any of the unit become faulty
- c) If any of the unit become OK from faulty
- ❖ In case of rotation Lowest Run hours Machine will have lowest logical ID if machine is not in fault
- ❖ Faulty machine will have highest logical ID
- ❖ Faulty machine is decided if any of the following condition meet
 - a) Machine does not communicate
 - b) Machine gets LP or HP alarm
 - c) Machine AC fails or Bad AC
 - d) Machine Compressor Fails
 - e) Fan Fail
- ❖ Above logic of Compressor is valid only when free cooling is not applicable

Example:

Setpoint: 22.0

Differential: 8

Max Run Hours: 4

Time	Temp	Fault				Logical ID				RUN STATE			
		M1	M2	M3	M4	M1	M2	M3	M4	M1	M2	M3	M4
00:00	26.1	N	N	N	N	1	2	3	4	ON	ON	OFF	OFF
01:00	26.6	N	N	N	N	1	2	3	4	ON	ON	OFF	OFF
02:00	25.4	N	Y	N	N	3	4	1	2	OFF	OFF	ON	OFF
03:00	25.1	N	N	N	N	3	4	2	1	OFF	OFF	OFF	ON
04:00	25.8	N	N	N	N	3	4	2	1	OFF	OFF	OFF	ON
05:00	25.7	N	N	N	N	3	4	2	1	OFF	OFF	OFF	ON
06:00	25.0	N	N	N	N	3	4	2	1	OFF	OFF	OFF	ON
07:00	25.7	N	N	N	N	2	3	1	4	OFF	OFF	ON	OFF
08:00	25.3	N	N	Y	N	1	2	4	3	ON	OFF	OFF	OFF
09:00	25.1	N	N	N	N	3	1	2	4	OFF	ON	OFF	OFF
10:00	27.2	N	N	N	N	3	1	2	4	OFF	ON	ON	OFF
11:00	26.8	N	N	N	N	1	3	2	4	ON	OFF	ON	OFF
12:00	26.5	N	N	N	N	1	2	3	4	ON	ON	OFF	OFF
13:00	26.2	N	Y	N	N	3	4	1	2	OFF	OFF	ON	ON
14:00	26.0	N	Y	N	N	3	4	1	2	OFF	OFF	ON	ON
15:00	25.8	N	Y	N	N	3	4	1	2	OFF	OFF	ON	ON
16:00	25.7	N	N	N	N	1	2	3	4	ON	OFF	OFF	OFF
17:00	26.1	N	N	N	N	1	2	3	4	ON	ON	OFF	OFF
18:00	23.0	N	N	N	N	1	2	3	4	ON	OFF	OFF	OFF

12. Modbus Register Map

12.1 Input registers (Function code 04):

Parameter	Unit	Description	Modbus Address
Indoor temp (Return Air)	°C		40100
Ambient temp	°C		40101
Evaporator temp (Supply Air)	°C		40102
Cooling Temperature	°C	Supply or return	40103
Software version			40104
Status			40105
System Alarm			40106
Sub cool Temperature	°C		40107
Superheat temperature	°C		40108
Low Pressure	Psi		40109
High Pressure	Psi		40110
Comp On time	S		40111
Run Mode			40112
Logic ID			40113
Run Hours	Hrs		40114
Run Hours	Hrs		40115
Individual Alarm Status1			40116
Individual Alarm Status2			40117
Individual Alarm Status3			40118
Individual Alarm Status4			40119
Individual Alarm Status5			40120
Individual Alarm Status6			40121
Individual Alarm Status7			40122
Individual Alarm Status8			40123
Fan1 PWM	%		40124
Fan2 PWM	%		40125
Fan3 PWM	%		40126
Reserved			40127
Reserved			40128
Reserved			40129
Reserved			40130
Reserved			40131
Reserved			40133- 40146
Number of History Logs			40147

12.2 Holding registers (Function code 03):

Parameter	Unit	Range	Default value	Modbus Address
Machine ID		0-8	1	30100
Return air temperature sensor		0-7	3	30101
Ambient temperature sensor		0-7	5	30102
Supply air temperature sensor		0-7	0	30103
Unit of measure		0=°C, 1=°F	0	30104
Minimum on time	S	60-1800	180	30105
Delay between 2 starts of the same compressor	S	60-1800	300	30106
Delay at start-up	S	0~255	30	30107
Comp rotation differential (Max On Time)	hr	1~48	8	30108
Evap FAN Min SPEED	%	0~100	40	30109
Evap FAN Max SPEED	%	0~100	90	30110
Temp set point for min fan SPEED	°C	0-50	20	30111
differential for max fan speed	°C	0.0~10.0	5	30112
Fan cut off temperature	°C	0~1-0.0	70	30113
Fixed fan speed when compressor ON	%	0-100	40	30114
Fan working mode during group control	-	0: always ON	0	30115
Fan working mode during BPA	-	0: Fan OFF (For AC operated Fan)	0	30116
Number of unit in group		1-8	4	30117
High temp alarm set point	°C	0-100	35	30118
HT alarm delay from the start-up	min	0~250	1	30119
Low temp alarm set point	°C	-40~176	5	30120
DTA threshold	°C	1.0~50.0	5	30121
DTA delay	S	0~255	10	30122
LP alarm reset	-	0: auto reset ; 1: manual reset	0	30123
Cooling set point	°C	0-100	20	30124
Cooling differential 1	°C	0.0~50.0	2	30125
Delta temperature to enable free-cooling	°C	1.0~50.0	5	30126
Differential of delta temperature	°C	1.0~50.0	1	30127
Emergency cooling Delta	°C	0-5	1.5	30128
Cooling Probe type	min	0- Return, 1-Supply	0	30129
Return temp probe offset	°C	-10.0 to +10.0	0	30130
Supply temp probe offset	°C	-10.0 to +10.0	0	30131

Ambient temp probe offset	°C	-10.0 to +10.0	0	30132
RTC Date time		Time Since EPOCH		30133
RTC Date time				30134
Remote ON/OFF		0 to 1	0	30135
Reset Alarms		0 to 1	0	30136

7. History Alarm:

Alarm History of 1000 alarms is stored in flash along with date time which can be downloaded through Modbus.

Function code: 04

Start address: 1600

Number of registers for each record: 16

Modbus Alarm Interpretation

Each History Alarm is stored in 32 bytes of memory.

Byte No.	Description
1.	Alarm Number
2.	Alarm Status
3.	Alarm Type
4.	Dummy
5.	Alarm Occurrence Date and time: Year
6.	Alarm Occurrence Date and time: Month
7.	Alarm Occurrence Date and time: Day
8.	Alarm Occurrence Date and time: Hour
9.	Alarm Occurrence Date and time: Minutes
10.	Alarm Occurrence Date and time: Seconds
11.	Alarm Retire Date and time: Year
12.	Alarm Retire Date and time: Month
13.	Alarm Retire Date and time: Day
14.	Alarm Retire Date and time: Hour
15.	Alarm Retire Date and time: Minutes
16.	Alarm Retire Date and time: Seconds
17-32	Dummy 0xFF

Alarm Number	Alarm Name
0.	DUMMY
1.	TEMP_SENS1_FAIL
2.	TEMP_SENS2_FAIL
3.	TEMP_SENS3_FAIL
4.	TEMP_SENS4_FAIL
5.	TEMP_SENS5_FAIL
6.	TEMP_SENS6_FAIL
7.	TEMP_SENS7_FAIL
8.	SENS1_FAIL
9.	SENS2_FAIL
10.	SENS3_FAIL

Alarm type is as below

11.	SENS4_FAIL
12.	SENS5_FAIL
13.	FAN1_FAIL
14.	FAN2_FAIL
15.	FAN3_FAIL
16.	RTC_FAIL
17.	EEPROM_FAIL
18.	FLASH_FAIL
19.	FIRE
20.	HIGH_TEMPERATURE
21.	LOW_TEMPERATURE
22.	HIGH_PRESSURE
23.	LOW_PRESSURE
24.	UNIT1_COMM_FAIL
25.	UNIT2_COMM_FAIL
26.	UNIT3_COMM_FAIL
27.	UNIT4_COMM_FAIL
28.	UNIT5_COMM_FAIL
29.	UNIT6_COMM_FAIL
30.	UNIT7_COMM_FAIL
31.	UNIT8_COMM_FAIL
32.	MULTI_UNIT_COMM_FAIL
33.	ANY_UNIT_COMM_FAIL
34.	AC_VOLTAGE_BAD
35.	TEMP_DIFFERENCE (DTA)
36.	COMP_FAIL

37.	DI1_ACTIVE
38.	DI2_ACTIVE
39.	DI3_ACTIVE
40.	DI4_ACTIVE
41.	DI5_ACTIVE
42.	DI6_ACTIVE
43.	DI7_ACTIVE
44.	DI8_ACTIVE
45.	FILTER_CHOKE
46.	FILTER_MISSING
47.	FILTER_DIRTY
48.	ALL_UNIT_COMM_FAIL
49.	FIRE_M1
50.	FIRE_M2
51.	FIRE_M3
52.	FIRE_M4
53.	FIRE_M5
54.	FIRE_M6
55.	FIRE_M7
56.	FIRE_M8

Example:

Modbus details for single event read

Function code: Read Input register (0x04)

Start address: 1600

Number of registers: 16

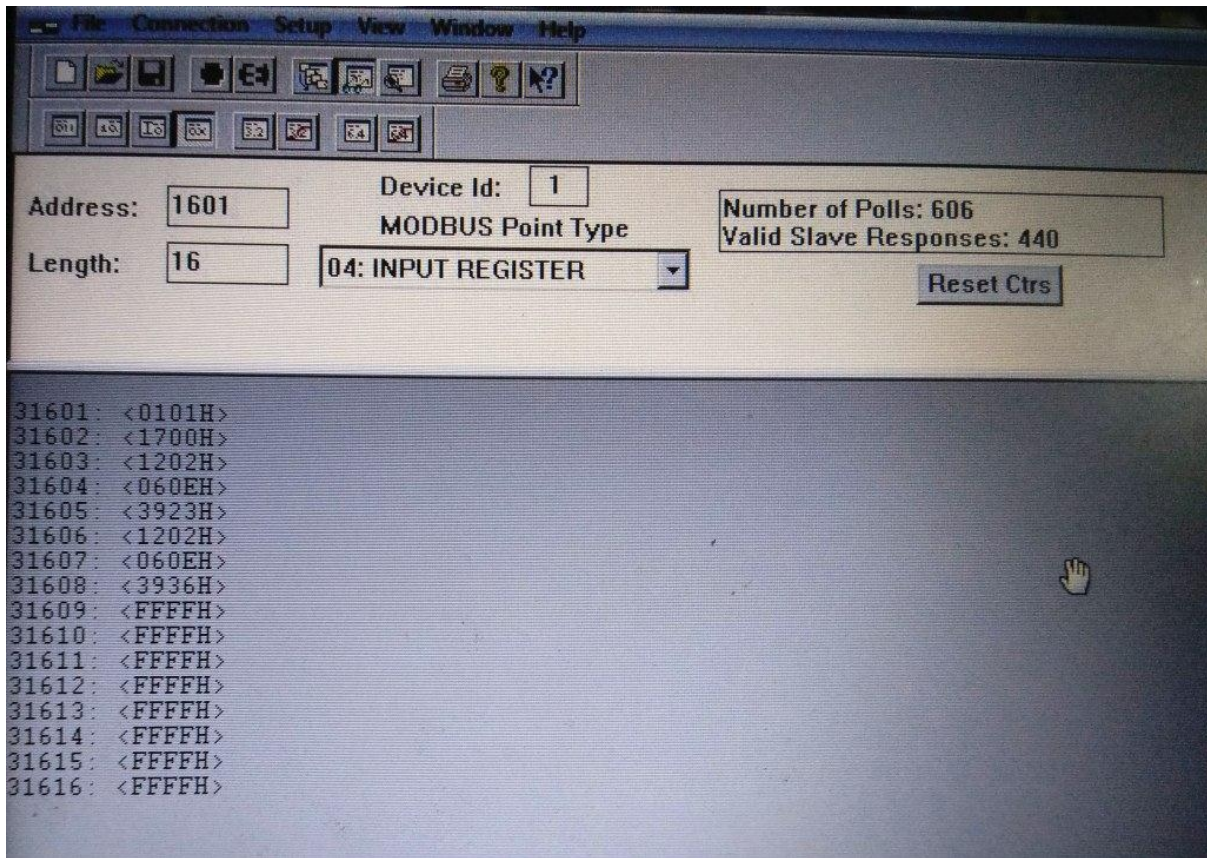

Byte No.	Description	Value
1.	Alarm Number	0x01
2.	Alarm Status	0x01
3.	Alarm Type	0x17 → 23 Low Pressure
4.	Dummy	0x00
5.	Alarm Occurrence Date and time: Year	0x12 → 18
6.	Alarm Occurrence Date and time: Month	0x02 → 2
7.	Alarm Occurrence Date and time: Day	0x06 → 6
8.	Alarm Occurrence Date and time: Hour	0x0E → 14
9.	Alarm Occurrence Date and time: Minutes	0X39 → 57
10.	Alarm Occurrence Date and time: Seconds	0X23 → 35
11.	Alarm Retire Date and time: Year	0x12 → 18
12.	Alarm Retire Date and time: Month	0x02 → 2
13.	Alarm Retire Date and time: Day	0x06 → 6
14.	Alarm Retire Date and time: Hour	0x0E → 14
15.	Alarm Retire Date and time: Minutes	0X39 → 57
16.	Alarm Retire Date and time: Seconds	0X36 → 54
17-32	Dummy 0xFF	

14.0 Trouble shooting guide

Problem	Possible Causes	Corrective Action
Unit does not emit cool air	Air is not circulating properly.	<ul style="list-style-type: none"> • Make sure that there are not curtains, blinds, or furniture blocking the front of the unit.
	The air filter is dirty.	<ul style="list-style-type: none"> • Clean the air filter once every month.
	The room temperature is too high.	<ul style="list-style-type: none"> • In summer, cooling the indoor air fully may take some time. In this case, select Power Cool to cool the indoor air quickly.
	Cold air is escaping from the room.	<ul style="list-style-type: none"> • Make sure that no cold air is escaping through ventilation points in the room.
	The desired temperature is higher than the set temperature.	<ul style="list-style-type: none"> • Set the desired temperature to a level lower than the current temperature.
	There is a heating source nearby.	<ul style="list-style-type: none"> • Avoid using heat generators like electric ovens or gas burners while the unit is operating.
	Outside temperature is too high.	<ul style="list-style-type: none"> • The cooling effect may not be sufficient.
The unit stops during operation.	The unit is suddenly turned off.	<ul style="list-style-type: none"> • Check whether any alarm in controller display.
	A power failure has occurred during operation.	<ul style="list-style-type: none"> • Wait for the power to come back. Your unit will resume in its last operation mode several minutes after power is restored.
The air outlet on the indoor unit is discharging mist.	The cooled air from the unit makes mist.	<ul style="list-style-type: none"> • When the room temperature decreases, the phenomenon will disappear.
Water leaks from the outdoor unit.	Drain chock and improper installation.	<ul style="list-style-type: none"> • This requires installing a drain hose under the base pan. Contact the installer.
There is a noise or vibration.	Flowing or Blowing sound: This is the flow of the refrigerant through the unit.	<ul style="list-style-type: none"> • These are normal occurrences. The noise will stop.
The indoor unit gives off an odor.	Odors (such as cigarette smoke) may be absorbed into the indoor unit and discharged with air flow.	<ul style="list-style-type: none"> • If the smell does not disappear, wash the air filter. If this does not work, contact service to clean the heat exchanger.

15.0 Commissioning / Preventive Maintenance Checklist

Customer :		Date :			
Site address :		Controller Details / Make :			
Model :		Controller Sr. # :			
SI # :		Commissioned by :			
<input type="checkbox"/> Please tick after each check is done		Please mention the values wherever necessary			
Physical checks		Electrical			
<input type="checkbox"/>	Installation of machines	Incoming voltage (volts)			
<input type="checkbox"/>	Sealing of gaps around the units	Loose connection			
<input type="checkbox"/>	Controller fitment	Earthing of units			
<input type="checkbox"/>	Grilles fitment	Earthing of controller			
<input type="checkbox"/>	Cleanliness of air filter	Total unit current (amp)			
<input type="checkbox"/>	Cleanliness of evaporator coil	Blower fan current (amp)	R		
<input type="checkbox"/>	Cleanliness of condenser coil	Condenser fan current (amp)	R		
<input type="checkbox"/>	Insulation fitment	Compressor current (amp)	R		
<input type="checkbox"/>	Fan rotation				
<input type="checkbox"/>	Condenser fan rotation				
<input type="checkbox"/>	Compressor rotation				
<input type="checkbox"/>	Blower fan free rotation				
<input type="checkbox"/>	Unit vibration if any				
<input type="checkbox"/>	Refrigerant pipes rubbing	Mechanical readings			
<input type="checkbox"/>	Oil trace / refrigerant leak if any	Compressor suction pressure			psig
<input type="checkbox"/>	Drain pipe clear for water movement	Compressor discharge pressure			psig
<input type="checkbox"/>	Unit changeover	Room temperature			°C
Remarks :		Controller settings			
		Mode of operation			
		Unit selection			
		Cycling hours			hr
		Temp. set points			°C
Customer's signature		Signature of C S E			

Country Office

Vertiv Energy (India) Private Ltd.

**Plot No. C-20, Road No. 19, Wagle Estate,
Thane (w), Maharashtra - 400 604. India.**

Tel.: 91-22-33154400

Fax: 91-22-25828358

Toll Free No 18002096070

Email: marketing.india@emerson.com



VERTIV™

E-mail : marketing.india@vertivco.com

Toll free : 1-800-2096070

VertivCo.com | Nitco Biz Park, 2nd Floor, Plot no. C-19, Road No.16U, Wagle Ind Estate, Thane (W), Maharashtra - 400604. India.

© 2016 Vertiv Co. All rights reserved.