

# LIEBERT® LIQUI-TECT™ 460 KIT

## ZONE LEAK-DETECTION SENSOR WITH CABLE

### Installation Guide



Liebert Liqui-tect™ Leak Detection Sensors install quickly and work simply for reliable detection of conductive aqueous fluid leaks.

The Liqui-tect 460 Sensor provides zone protection using the easy-to-install and quick-drying Liebert leak detection cable. LEDs on the top cover provide visual indication. A reset button provides optional manual acknowledgement of alarms.

The top cover is hinged, for easy access to the electronics inside the steel enclosure. Terminal blocks allow easy interconnection of power and alarm outputs.

Dual Form-C relay outputs simultaneously signal the local alarm panel and remote monitoring system. The sensor features supervised operation through alarms for cable faults, circuit failure or loss of power,

ensuring a completely self-monitored leak detection system.

The LT460 is available in packaged kits with 20, 25, 30, 35 or 45 feet of leak detection cable and hold-down clips. Note that additional cable cannot be added to packaged kits.

The LT460 sensor can also be purchased independently. The sensor can accommodate up to 100 feet of leak detection cable.

### DIMENSIONS - TOP, FRONT AND SIDE

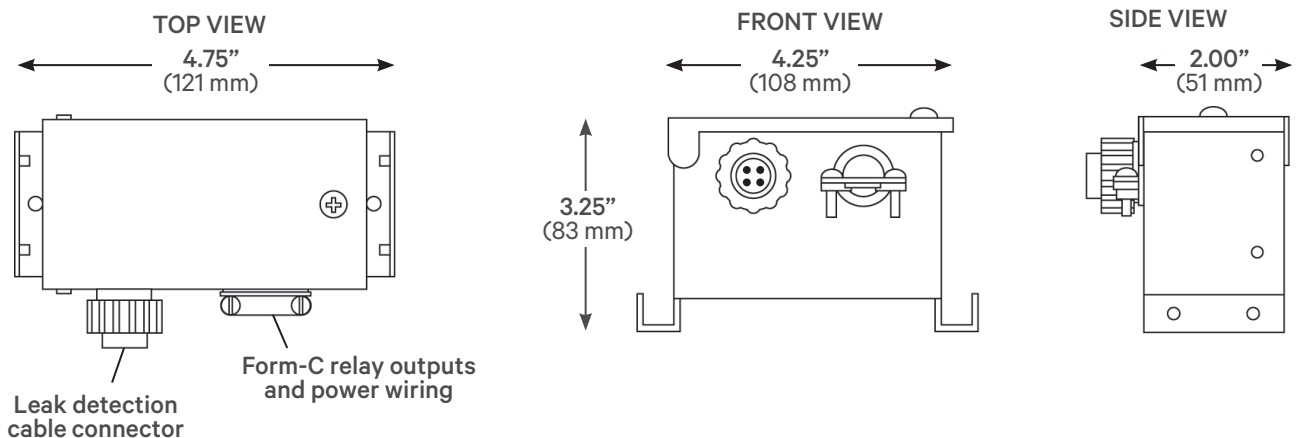

As shown in the illustration on the next page, the Liqui-tect 460 (LT460) may be placed on a subfloor, where it is connected to the leak detection cable that surrounds the leak detection zone—the area directly beneath the unit being protected or other areas such as the perimeter of a room.

**NOTE:** For a downflow unit, the leak detection cable must be located six feet in front of the unit.

The LT460 requires a 24 VAC power supply from the environmental unit or an external source. There are two sets of Form-C dry contacts for connection to a Liebert environmental unit and an external monitoring panel.

### Detection-cable Placement Precautions

- Do not use detection cable that is damaged or dirty (from plaster, spackle or construction debris.)
- Do not drag detection cable through contaminants (dirty or greasy areas). Floor must be clean for the detection cable to function properly and for the hold-down clips to adhere to the floor surface.

- Take careful consideration to place detection cable out of the direct discharge airflow path of environmental equipment, which can discharge moisture into the airflow. Place cable 6 ft from discharge to avoid nuisance alarms during humidification.
- Tools or heavy objects can do permanent damage when dropped, rolled, or set on the detection cable. Avoid foot traffic on the detection cable as well.
- Do not use any type of adhesive tape to secure the detection cable.
- Do not allow soldering or welding near the detection cable without providing protection from heat or contaminants. (Also avoid installing the detection cable in or near these type of areas.)
- Mild dishwashing liquid can be used to clean the detection cable of many contaminants.

### Installation of Leak Detection System Cable

1. Attach the leak detection cable to the LT460 module, activate module and test detection cable. (Touch detection cable with a clean moist cloth or paper towel.)

Dry detection cable to remove the alarm condition. (A hair dryer can be used to speed up the drying.)

**NOTE:** Do not try to saturate the detection cable for testing. It only requires a small amount of water to alarm. The detection cable must dry for the alarm condition to clear.

2. Install the hold-down clips in pairs in pairs as shown in the figure below, and one pair as needed to maintain consistent uniform contact between the floor and detection cable.

**IMPORTANT:** Be certain the detection cable is protected from the adhesive installation for the hold-down clips. No adhesive should come in contact with the detection cable.

3. Once adhesive is completely dry, snap the cable into each hold-down clip.
4. Check that there are no gaps between the floor and detection cable. (Add clips as required.)
5. Be certain there are no alarms present on the module, and do final testing as per instruction in Step 1.

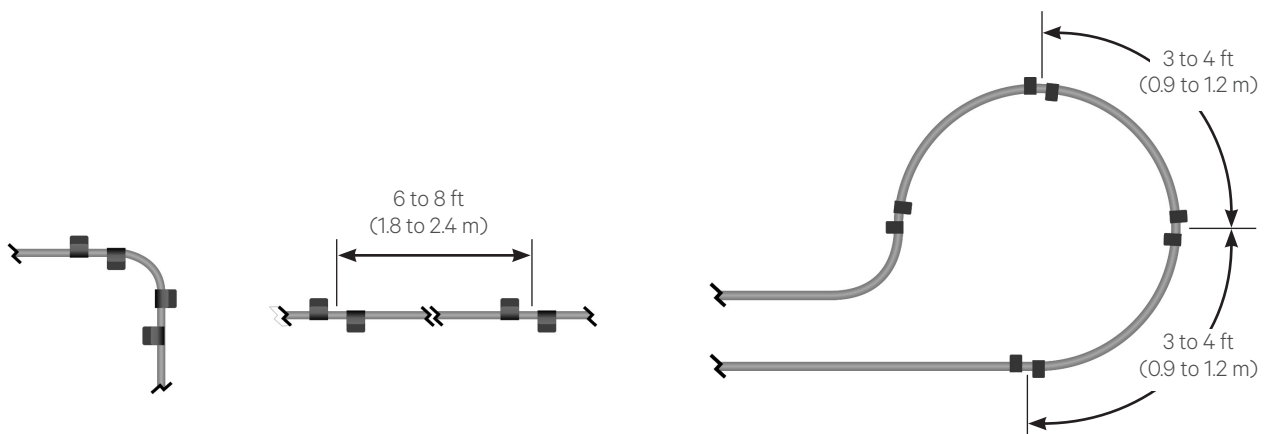

**PLACEMENT ON SUBFLOOR UNDER COOLING SUPPORT EQUIPMENT**

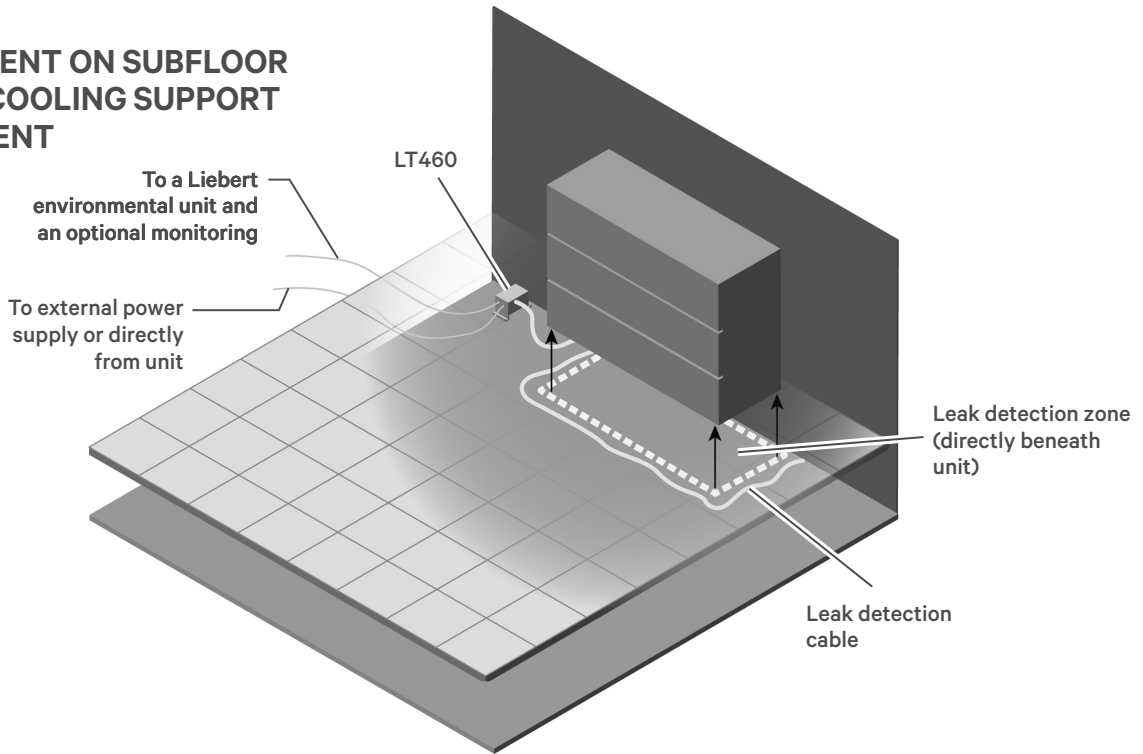

**Leak-detection Kit Installation Scenarios**

Refer to the documentation included with your Liebert Thermal Management system for configuration and dimensions and the table below to calculate the length of the leak-detection cable required for proper placement of the cable.

**SCENARIO BY UNIT CONFIGURATION**

Cable clearance (distance from unit)	Upflow around unit	Upflow sides and front	Downflow around unit	Downflow sides and front
Back	2 ft	No cable behind	1 ft	No cable behind
Sides	2 ft	2 ft	1 ft	1 ft
Front	2 ft	2 ft	6 ft	6 ft

## POWER WIRING

The LT460 is rated for 24 VAC, 50/60 Hz, and 0.12 A.

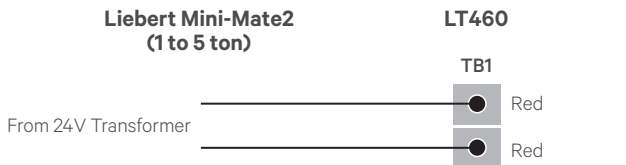
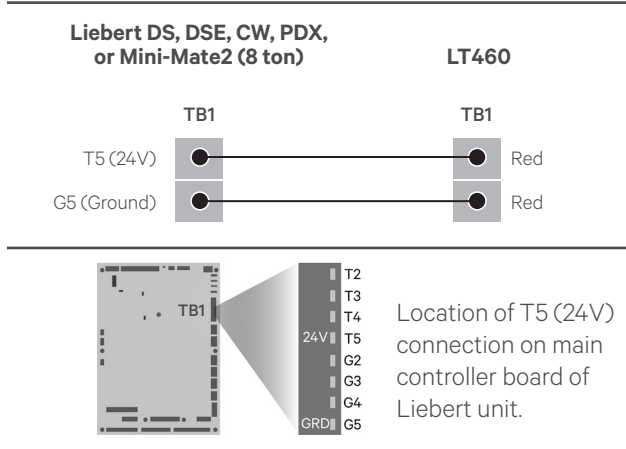

\* Requires external transformer (there are no designated terminal connections on the unit)

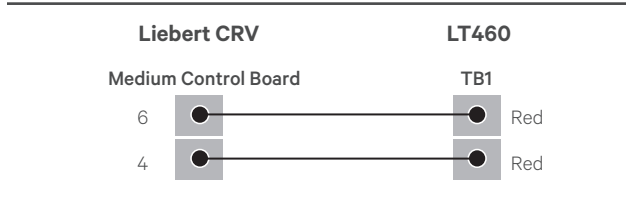

## WIRING TO AUXILIARY ALARM PANELS

The LT460 has two Form-C dry-contact alarm-output contacts (TB2 and TB3). Each contact is rated for 24 VAC at 3 amp..

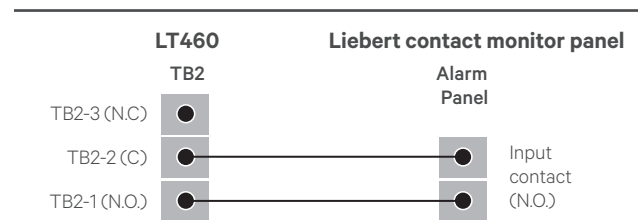
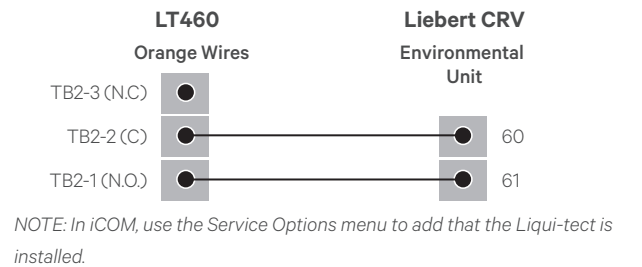
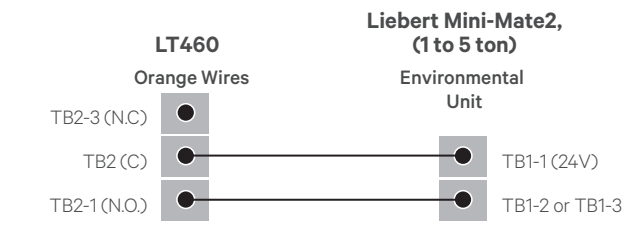
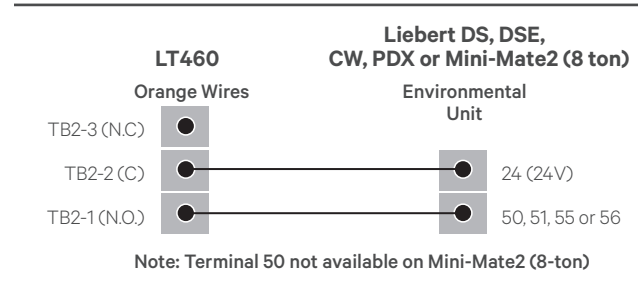

## CONFIGURATION-SWITCH SETTINGS

A 4-position DIP switch selects two alarm (filter) delays and three mutually-exclusive alarm modes. The switches are located next to the wiring termination blocks.

SWITCH SETTINGS	OFF	ON
1. Leak Detect Filter	10 sec	2 min
2. Alarm Latch	No	Yes
3. Alarm Retest Delay	No	1 hr
4. Not Used	-	-

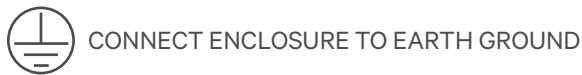

### ALL CIRCUITS: CLASS 2

Contacts shown in POWERED, NON-ALARM state

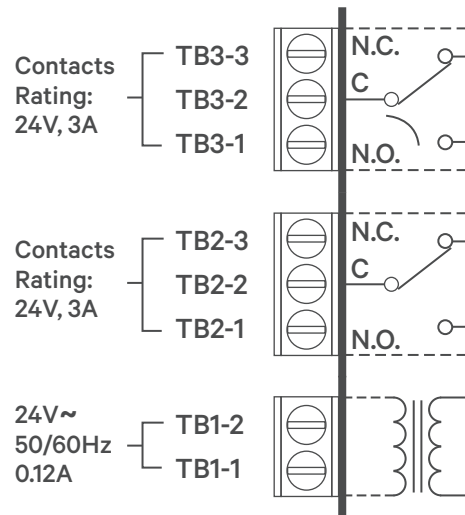

## SWITCH-SETTINGS SUMMARY

SS2	SS2	SS3	SS4	MODE
OFF	OFF	OFF	not used	Non-latching, 10-second filter delay (factory default)
ON	OFF	OFF	not used	Non-latching, 2-minute filter delay
OFF	ON	—	not used	Latching, 10-second filter delay
ON	ON	—	not used	Latching, 2-minute filter delay
OFF	OFF	ON	not used	1-hour latch/retest, 10-second filter delay
ON	OFF	ON	not used	1-hour latch/retest, 2-minute filter delay

### Leak Detect Filter Delay(SS1)

SS1 selects the leak detect filter delay, the interval for which a leak condition must be continuously detected before an alarm is triggered:

- OFF = 10 seconds (default)
- ON = 2 minutes

This feature is useful for eliminating nuisance alarms. SS1 works independently of the settings of SS2 and SS3. While the alarm delay is selectable (factory default is OFF=10 seconds), the cable fault delay is preset at approximately 2 seconds.

### Latching or Non-Latching Alarms (SS2)

SS2 selects latching or non-latching alarms, the setting in which an alarm will latch ON until manually reset:

- OFF=Non-latching (default)
- ON=Latching

The factory default is OFF=Non-latching. If the sensor is in latching mode (ON=Latching) and the leak condition clears itself in the interim, a manual reset is required. While the alarm is latched, the sensor goes into a “sleep” mode and power to the leak detection cable is discontinued. Depowering the cable prevents damage to the cable should it be in contact with the conductive liquid for an extended duration. After a manual reset, the sensor resumes its normal operation, continuously checking for leaks. If the leak condition has not yet cleared but the sensor is manually reset, the sensor will re-alarm after the appropriate leak detect filter delay. SS2 in the ON position will disable the operation of SS3.

### Alarm Retest Delay (SS3)

SS3 selects the alarm retest delay, the setting in which an alarm is latched and retested every hour.

- OFF=Non-latching (default)
- ON=Latching-retest each hour

The factory default is OFF=Non-latching. If SS3=ON and a leak is detected, the alarm condition is latched, the sensor goes into a “sleep” mode and power to the leak detection cable is discontinued. After one hour, the sensor will automatically retest if the leak is still present. If the leak has cleared itself, the sensor deactivates the alarm, resets itself and resumes normal operation; if the leak is still present, the alarm condition remains activated and the sensor goes to “sleep” and retests in another hour. This procedure will repeat indefinitely until the leak is cleared or until the alarm is manually reset.

A manual reset can be initiated at any time. If the leak condition has not yet cleared, the sensor re-alarms after the selected leak detect filter delay; if the leak has cleared, the sensor deactivates the alarm and resets itself. SS3 is disabled if SS2=ON.

The factory default settings of SS2=OFF and SS3=OFF place the sensor in a nonlatching, continuous retest mode. The sensor does not go to “sleep” after detecting a leak—instead, it continually checks to determine whether the leak condition has cleared itself. Alarms automatically reset when the leak condition clears. Initiating a manual reset will cause the sensor to trigger the alarm again after the selected leak detect filter delay. The leak detect cable remains powered at all times.

SS4 is not used.

## LED OPERATION

### System Normal (Green):

- ON continuously when power is applied to sensor.

### Alarm Pending (Yellow):

- ON continuously during leak detect filter delay and cable fault delay.
- FLASHING (with Leak Detected LED) to indicate cable fault condition.

### Leak Detected (Red):

- FLASHING to indicate leak detected alarm.
- FLASHING (with Alarm Pending LED) to indicate cable fault condition.

## NOTES

This equipment has been tested and found to comply with the limits for a Class A digital device, pursuant to part 15 of FCC rules. These limits are designed to provide reasonable protection against harmful interference when the equipment is operated in a commercial environment. This equipment generates, uses, and can radiate radio frequency energy and, if not installed and used in accordance with the instruction manual, may cause harmful interference to radio communications. Operation of this equipment in a residential area is likely to cause harmful interference in which case the user will be required to correct the interference at his own expense.

In the event of a severe leak causing submersion or partial-submersion of the enclosure and/or the electronic circuitry inside the enclosure, the entire module should be returned to the factory for inspection.

