



# Performance Improvements with Sharing Inductors in Distributed Static Switch UPS Systems

Technical Note

Simplified Installation and Improved Performance

# TABLE OF CONTENTS

**1.0 INTRODUCTION..... 1**  
**2.0 BYPASS SHARING FOR REDUNDANCY AND CAPACITY..... 1**  
**3.0 BYPASS POWER SHARING WITH CABLING IMPEDANCE DIFFERENCES.  
2**

## FIGURES

Figure 1 Typical Distributed Bypass Electrical Circuit..... 2

## TABLES

Table 1 Liebert® NXL™ 750kVA UPS: Comparison of Load Percent Distribution for Various Load Cable Differences between Systems With and Without Sharing Inductors..... 3  
Table 2 Liebert® EXL™ 800kVA UPS: Comparison of Load Percent Distribution for Various Load Cable Differences between Systems With Sharing Inductors ..... 4  
Table 3 Liebert EXL™ S1 1200kVA UPS: Comparison of Load Percent Distribution for Various Load Cable Differences between Systems With and Without Sharing Inductors..... 5  
Table 4 Liebert NX™ 300kVA UPS: Comparison of Load Percent Distribution for Various Load Cable Differences between Systems With and Without Sharing Inductors..... 6  
Table 5 Liebert NX™ 600kVA UPS: Comparison of Load Percent Distribution for Various Load Cable Differences between Systems With and Without Sharing Inductors..... 7

# 1.0 INTRODUCTION

This paper explains how the impedances of the bypass paths should be controlled for paralleled distributed static switch systems and provides recommendations for controlling the cabling impedances to ensure efficient bypass power sharing.

A distributed static switch system operating on bypass does not control the power flowing through the bypass path. Bypass power sharing can be aided only by adding bypass sharing inductors in the UPS modules.

In large UPS systems, redundancy is defined as having at least one more UPS module than is required to feed the entire load should a single module be removed. Without redundancy, a system can carry the load of the data center only with all UPS modules in full operation. If two UPS modules are paralleled and the impedance in each bypass path is identical then each unit will have exactly 50 percent of the load at the critical bus while on bypass. Any mismatch in the impedance will cause one unit to have more than 50 percent of the load while the other UPS will have less than 50 percent.

For a distributed static switch UPS system, the impedances in the bypass paths must be matched sufficiently in order for each module to carry its rated load. If not, a full system load could cause one UPS to have, for example, 120 percent of the load and the other only 80 percent, which will cause one UPS to be overloaded and shutdown the entire load.

# 2.0 BYPASS SHARING FOR REDUNDANCY AND CAPACITY

One UPS unit can be removed in a redundant system while the critical load remains supplied from a conditioned, uninterruptible power source. Accurate bypass sharing is not critical, as the load on the bypass paths will never near 100 percent full load. However, if the redundant module is off-line, then bypass sharing becomes important.

In a capacity system, the total critical load is such that all UPS's must be on-line to support the load; each UPS must be on and adequately sharing power under all circumstances. When operating on bypass, it is a function of impedance differences between each unit's bypass paths for the bypass circuits to share power.

**Figure 1** illustrates the simplified electrical circuit paths for the distributed bypass system. The circuit is composed of four impedance elements:

- Input cabling impedance
- Back-Feed Breaker (BFB)
- Bypass sharing inductors
- Output cabling impedance

These are summed together to create the total impedance of the bypass path.

**Figure 1** shows typical location of sharing inductors; however, the location can vary depending on site requirements and system design.

Data in **Tables 1** through **5** show the cabling impedance is based on both the input and output cabling of the UPS bypass path. It is assumed that the system paralleling cabinet has no impedance. The impedance from the system paralleling cabinet to the load (which does not affect the sharing) is assumed to be negligible. For this example, the cabling is determined based on the Vertiv-recommended conductor size and number of conductors per phase.

**Figure 1 Typical Distributed Bypass Electrical Circuit**

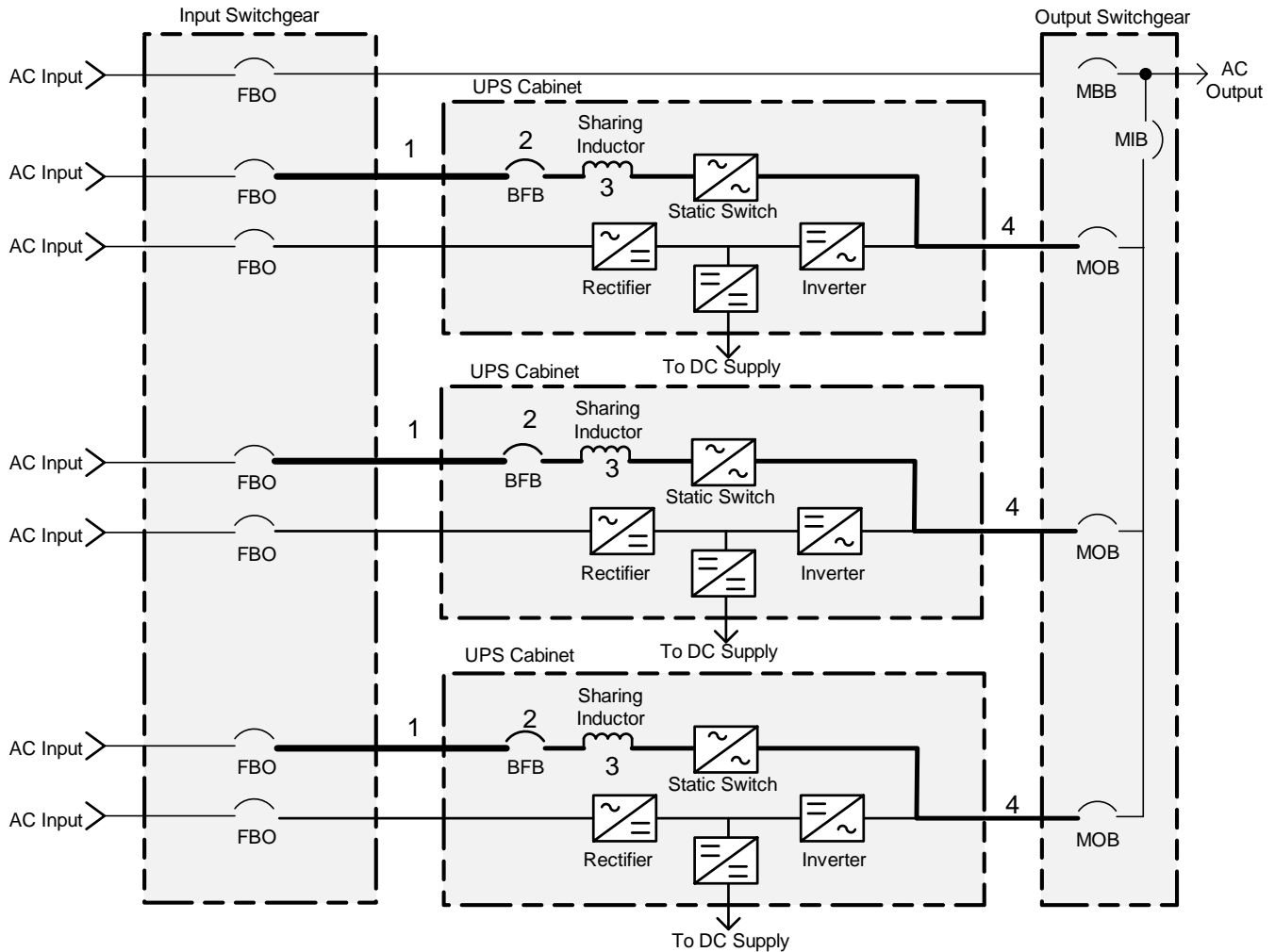

**NOTE**

*in some UPS designs, inductive elements may be in the circuit whether the UPS is on bypass or inverter, in which case additional sharing inductors in the bypass line only may not be required.*

### 3.0 BYPASS POWER SHARING WITH CABLING IMPEDANCE DIFFERENCES

**Table 1** shows the impact of varying distributed bypass path cable length on load sharing for a system of three Liebert NXL™ 750kVA UPS units at 0.9 power factor. Based on a distributed bypass system of three 800kVA Liebert EXL™ UPS units with 2,400kVA of load at 1.0 power factor, **Table 2** shows the bypass load sharing when the cabling length is varied while the UPS modules power the load via their static bypass switches.

The Liebert EXL distributed bypass modules have factory-installed sharing inductors to minimize the effects of cable impedance mismatch. **Table 3** illustrates the impact of varying the bypass path cable length on load sharing for a system of four 1200kVA Liebert EXL S1 units with 4,800kVA of load at 1.0 power factor. **Tables 4,** and **5** illustrate the impact of varying the bypass path

cable length on load sharing on a system of four 300kVA and 600kVA Liebert NX™ UPS units at 1.0 power factor.

The data tables are grouped according to UPS type and bypass cable length. The first row of data provides the generic information for equal lengths of cable per UPS and subsequent rows of data show the load percent variation on each UPS with one UPS's cable length increased by a percentage of the other UPS's. The left half of each table shows the current sharing difference **with** sharing inductors. The right half of each table shows the same load percent variation **without** sharing inductors, such as with non-Liebert UPS systems. The shaded data indicates the individual UPS is in an overload situation sufficient to cause a breaker trip and load shutdown.

The data in **Tables 1** through **5** show that it is important to have bypass sharing inductors to help control the cabling impedances due to likely variations in cable length if the bypass paths are to share the power without an overload situation. The effect of cabling differences amplifies for capacity systems as the number of paralleled UPS modules increases

**Table 1 Liebert® NXL™ 750kVA UPS: Comparison of Load Percent Distribution for Various Load Cable Differences between Systems With and Without Sharing Inductors**

<b>With Sharing Inductors, 100% System Load (4) 600kcmil per phase, 0.9 PF</b>				<b>Without Sharing Inductors, 100% System Load (4) 600kcmil per phase, 0.9 PF</b>			
<b>Bypass cable length: 50ft</b>				<b>Bypass cable length: 50ft</b>			
<b>% Cable Difference</b>	<b>% Load UPS #1</b>	<b>% Load UPS #2</b>	<b>% Load UPS #3</b>	<b>% Cable Difference</b>	<b>% Load UPS #1</b>	<b>% Load UPS #2</b>	<b>% Load UPS #3</b>
0	100	100	100	0	100	100	100
10	99.6	99.6	100.8	10	96.4	96.4	107.1
25	99	99	102	25	90	90	120
50	98	98	104.1	50	75	75	150
<b>Bypass Cable Length: 75ft</b>				<b>Bypass Cable Length: 75ft</b>			
0	100	100	100	0	100	100	100
10	99.4	99.4	101.1	10	96.4	96.4	107.1
25	98.6	98.6	102.9	25	90	90	120
50	97.1	97.1	106	50	75	75	150
<b>Bypass Cable Length: 100ft</b>				<b>Bypass Cable Length: 100ft</b>			
0	100	100	100	0	100	100	100
10	99.3	99.3	101.5	10	96.4	96.4	107.1
25	98.1	98.1	103.7	25	90	90	120
50	96.2	96.2	107.7	50	75	75	150
<b>Bypass Cable Length: 125ft</b>				<b>Bypass Cable Length: 125ft</b>			
0	100	100	100	0	100	100	100
10	99.1	99.1	101.8	10	96.4	96.4	107.1
25	97.8	97.8	104.5	25	90	90	120
50	95.4	95.4	109.3	50	75	75	150

Shaded cells indicate overloaded unit leading to breaker trip and load shutdown

**Table 2 Liebert® EXL™ 800kVA UPS: Comparison of Load Percent Distribution for Various Load Cable Differences between Systems With Sharing Inductors**

<b>With Sharing Inductors, 100% System Load (3) 500kcmil per phase, unity PF</b>			
<b>Bypass Cable Length: 50ft</b>			
<b>% Cable Difference</b>	<b>% Load UPS #1</b>	<b>% Load UPS #2</b>	<b>% Load UPS #3</b>
0	100	100	100
10	99.5	99.5	101.1
25	98.6	98.6	102.8
50	97.2	97.2	105.8
<b>Bypass Cable Length: 75ft</b>			
0	100	100	100
10	99.2	99.2	101.6
25	98	98	104
50	96	96	108.3
<b>Bypass Cable Length: 100ft</b>			
0	100	100	100
10	99	99	102
25	97.5	97.5	105.1
50	94.9	94.9	110.6
<b>Bypass Cable Length: 125ft</b>			
0	100	100	100
10	98.9	98.9	102.3
25	97.1	97.1	106
50	93.8	93.8	112.8

Shaded cells indicate overloaded unit leading to breaker trip and load shutdown

**Table 3 Liebert EXL™ S1 1200kVA UPS: Comparison of Load Percent Distribution for Various Load Cable Differences between Systems With and Without Sharing Inductors**

<i>With Sharing Inductors, 100% System Load (6) 500kcmil per phase, unity PF</i>					<i>Without Sharing Inductors, 100% System Load (6) 500kcmil per phase, unity PF</i>				
<b>Bypass cable length: 50 ft.</b>					<b>Bypass cable length: 50 ft.</b>				
<b>% Cable Difference</b>	<b>% Load UPS #1</b>	<b>% Load UPS #2</b>	<b>% Load UPS #3</b>	<b>% Load UPS #4</b>	<b>% Cable Difference</b>	<b>% Load UPS #1</b>	<b>% Load UPS #2</b>	<b>% Load UPS #3</b>	<b>% Load UPS #4</b>
0	100	100	100	100	0	100	100	100	100
10	99.7	99.7	99.7	101.0	10	97.6	97.6	97.6	107.3
25	99.2	99.2	99.2	102.4	25	94.1	94.1	94.1	117.7
50	98.4	98.4	98.4	104.7	50	88.9	88.9	88.9	133.4
<b>Bypass cable length: 75 ft.</b>					<b>Bypass cable length: 75 ft.</b>				
0	100	100	100	100	0	100	100	100	100
10	99.6	99.6	99.6	101.4	10	97.6	97.6	97.6	107.3
25	98.9	98.9	98.9	103.4	25	94.1	94.1	94.1	117.7
50	97.8	97.8	97.8	106.7	50	88.9	88.9	88.9	133.3
<b>Bypass cable length: 100 ft.</b>					<b>Bypass cable length: 100 ft.</b>				
0	100	100	100	100	0	100	100	100	100
10	99.4	99.4	99.4	101.7	10	97.6	97.6	97.6	107.3
25	98.6	98.6	98.6	104.3	25	94.1	94.1	94.1	117.7
50	97.2	97.2	97.2	108.5	50	88.9	88.9	88.9	133.3
<b>Bypass cable length: 125 ft.</b>					<b>Bypass cable length: 125 ft.</b>				
0	100	100	100	100	0	100	100	100	100
10	99.3	99.3	99.3	102.1	10	97.6	97.6	97.6	107.3
25	98.3	98.3	98.3	105.1	25	94.1	94.1	94.1	117.7
50	96.7	96.7	96.7	110.1	50	88.9	88.9	88.9	133.3

Shaded cells indicate overloaded unit leading to breaker trip and load shutdown.



**Table 4 Liebert NX™ 300kVA UPS: Comparison of Load Percent Distribution for Various Load Cable Differences between Systems With and Without Sharing Inductors**

<i>With Sharing Inductors, 100% System Load (2) 4/0awg per phase, unity PF</i>					<i>Without Sharing Inductors, 100% System Load (2) 4/0awg per phase, unity PF</i>				
<b>Bypass Cable Length: 50ft</b>					<b>Bypass Cable Length: 50ft</b>				
<b>% Cable Difference</b>	<b>% Load UPS #1</b>	<b>% Load UPS #2</b>	<b>% Load UPS #3</b>	<b>% Load UPS #4</b>	<b>% Cable Difference</b>	<b>% Load UPS #1</b>	<b>% Load UPS #2</b>	<b>% Load UPS #3</b>	<b>% Load UPS #4</b>
0	100	100	100	100	0	100	100	100	100
10	99.9	99.9	99.9	100.4	10	97.3	97.3	97.3	108.1
25	99.7	99.7	99.7	101.1	25	92.3	92.3	92.3	123.1
50	99.3	99.3	99.3	102.2	50	80	80	80	160
<b>Bypass Cable Length: 75ft</b>					<b>Bypass Cable Length: 75ft</b>				
0	100	100	100	100	0	100	100	100	100
10	99.7	99.7	99.7	100.9	10	97.3	97.3	97.3	108.1
25	99.3	99.3	99.3	102.2	25	92.3	92.3	92.3	123.1
50	98.6	98.6	98.6	104.4	50	80	80	80	160
<b>Bypass Cable Length: 100ft</b>					<b>Bypass Cable Length: 100ft</b>				
0	100	100	100	100	0	100	100	100	100
10	99.6	99.6	99.6	101.3	10	97.3	97.3	97.3	108.1
25	99	99	99	103.2	25	92.3	92.3	92.3	123.1
50	97.9	97.9	97.9	106.6	50	80	80	80	160.1
<b>Bypass Cable Length: 125ft</b>					<b>Bypass Cable Length: 125ft</b>				
0	100	100	100	100	0	100	100	100	100
10	99.5	99.5	99.5	101.7	10	97.3	97.3	97.3	108.1
25	98.6	98.6	98.6	104.3	25	92.3	92.3	92.3	123.1
50	97.3	97.3	97.3	108.8	50	80.1	80.1	80.1	160.1

Shaded cells indicate overloaded unit leading to breaker trip and load shutdown

**Table 5 Liebert NX™ 600kVA UPS: Comparison of Load Percent Distribution for Various Load Cable Differences between Systems With and Without Sharing Inductors**

<i>With Sharing Inductors, 100% System Load (3) 350kcmil per phase, unity PF</i>					<i>Without Sharing Inductors, 100% System Load (3) 350kcmil per phase, unity PF</i>				
<b>Bypass Cable Length: 50ft</b>					<b>Bypass Cable Length: 50ft</b>				
<b>% Cable Difference</b>	<b>% Load UPS #1</b>	<b>% Load UPS #2</b>	<b>% Load UPS #3</b>	<b>% Load UPS #4</b>	<b>% Cable Difference</b>	<b>% Load UPS #1</b>	<b>% Load UPS #2</b>	<b>% Load UPS #3</b>	<b>% Load UPS #4</b>
0	100	100	100	100	0	100	100	100	100
10	99.8	99.8	99.8	100.5	10	97.3	97.3	97.3	108.1
25	99.6	99.6	99.6	101.3	25	92.3	92.3	92.3	123.1
50	99.1	99.1	99.1	102.7	50	80	80	80	160
<b>Bypass Cable Length: 75ft.</b>					<b>Bypass Cable Length: 75ft.</b>				
0	100	100	100	100	0	100	100	100	100
10	99.7	99.7	99.7	101	10	97.3	97.3	97.3	108.1
25	99.1	99.1	99.1	102.6	25	92.3	92.3	92.3	123.1
50	98.3	98.3	98.3	105.3	50	80	80	80	160.1
<b>Bypass Cable Length: 100ft.</b>					<b>Bypass Cable Length: 100ft.</b>				
0	100	100	100	100	0	100	100	100	100
10	99.5	99.5	99.5	101.5	10	97.3	97.3	97.3	108.1
25	98.8	98.8	98.8	103.8	25	92.3	92.3	92.3	123.1
50	97.5	97.5	97.5	107.8	50	80	80	80	160.1
<b>Bypass Cable Length: 125ft</b>					<b>Bypass Cable Length: 125ft</b>				
0	100	100	100	100	0	100	100	100	100
10	99.4	99.4	99.4	101.9	10	97.3	97.3	97.3	108.1
25	98.4	98.4	98.4	104.9	25	92.3	92.3	92.3	123.1
0	96.8	96.8	96.8	110.1	50	80.1	80.1	80.1	160.1

Shaded cells indicate overloaded unit leading to breaker trip and load shutdown

## Recommendations

The impedances of the bypass paths need to be controlled for paralleled distributed static switch systems.

The impedances can be controlled by providing similar lengths of cable to and from each UPS module. The cabling impedance for a parallel system should be matched as closely as possible. The design and layout of the UPS system, associated panels and cabling should ensure that cable lengths and impedances are evenly-matched.

The sharing inductors' impedance compensates for reasonable impedance system mismatches as shown in the tables within this document. For certain Liebert large facility UPS's sharing inductors are required for distributed bypass capacity systems and recommended for 1+1 redundant systems. These minimize the chance of an overload situation when the UPS system operates at full capacity.

## Notes





