

**DISCONTINUED
PRODUCT**



POWER PROTECTION

SmartSwitch™

Automatic Transfer Switch

Installation and Operation Manual



**DISCONTINUED
PRODUCT**

TABLE OF CONTENTS

IMPORTANT SAFETY INSTRUCTIONS	1
1.0 INTRODUCTION	2
1.1 Specifications	2
1.1.1 General Specifications	2
1.1.2 Electrical Specifications	3
1.1.3 Environmental Specifications	3
2.0 UNPACKING AND INSTALLATION	5
2.1 Location Considerations	5
2.2 Input and Output Power Connections	6
2.3 Grounding	10
2.4 Control Wiring Connections	10
3.0 OPERATING INSTRUCTIONS	11
3.1 Description of SmartSwitch Operation	11
3.2 Status Indicators	11
3.3 RS-232 Communications Port	12
4.0 OPERATOR CONTROLS	14
4.1 Bypass/Transfer Control Switch	14
5.0 OPERATING GUIDELINES	15
6.0 MAINTENANCE	17

FIGURES

Figure 1	Typical SmartSwitch One-Line Diagram	2
Figure 2	Typical 15 to 20 Amp SmartSwitch Rackmount Unit	7
Figure 3	Typical 25 to 60 Amp SmartSwitch Underfloor / Wallmount Unit	8
Figure 4	Typical Input and Output Power Connections	9
Figure 5	Control Wiring Connections	10
Figure 6	Bypass / Transfer Control Switch	14

TABLES

Table 1	SmartSwitch™ Ratings	4
Table 2	SmartSwitch Status Indicators	11
Table 3	RS-232 ASCII Communication Port Customer Commands	12
Table 4	Example View Status Response	12
Table 5	Example View Event Log Response	13
Table 6	Example View Settings Response	13
Table 7		

IMPORTANT SAFETY INSTRUCTIONS



WARNING

THERE ARE NO USER-SERVICEABLE PARTS INSIDE THE REMOVABLE ELECTRONICS MODULE. OPENING OR REMOVING THE COVER OF THE REMOVABLE ELECTRONICS MODULE MAY EXPOSE HAZARDOUS VOLTAGES, EVEN WHEN THE SMARTSWITCH™ IS IN BYPASS. DO NOT ATTEMPT TO SERVICE THIS PRODUCT YOURSELF. REFER ALL SERVICING TO QUALIFIED SERVICE PERSONNEL.



NOTE

Read the entire User's Manual before installing and operating the SmartSwitch. Adhere to all operating instructions and warnings on the unit and in this manual.

Liebert Corporation neither recommends nor knowingly sells this product for use with life support or other FDA-designated "critical" devices.

The SmartSwitch is suitable for indoor use only. Protect unit from excessive moisture and install in an area free from flammable liquids, gases, or corrosive substances.

The unit is designed to operate from solidly grounded AC power sources only. Provide input overcurrent protection in accordance with the unit ratings. Wire and ground the unit according to national and local electrical safety codes.



CAUTION

The unit is supplied by two power sources. Unit may be electrically live if either of the two input sources is ON, even when the electronics module is removed. To isolate the unit, turn OFF and lock out BOTH input power sources.



CAUTION

If unit is furnished with input power plugs, the ground (earth) leakage current must not exceed 2.75 milliamperes. Most information technology equipment meets this requirement if no more than 4 pieces of equipment are powered from this unit. Note: These instructions may be modified by local wiring regulations.



CAUTION

This unit complies with the limits for a Class A digital device, pursuant to Part 15 Subpart J of the FCC rules. These limits provide reasonable protection against harmful interference in a commercial environment. This unit generates, uses and radiates radio frequency energy and, if not installed and used in accordance with this instruction manual, may cause harmful interference to radio communications. Operation of this unit in a residential area may cause harmful interference which the user must correct at his own expense.

1.0 INTRODUCTION

The SmartSwitch™ is an automatic transfer switch designed to provide fast automatic transfers between two independent, synchronous AC power sources to provide continuity of AC power to critical equipment, such as information technology equipment, despite irregularities in either of the two AC input power sources. The transfer is accomplished with sense and transfer times of less than 6 milliseconds. The SmartSwitch is available in a 2, 3, or 4 pole configurations, with ampacities of 13, 15, 20, 25, 30, 50, or 60 amps, in a floor, wall, or rack mount packages. Inputs may be hardwired or plug connected to the two input branch circuits. Outputs may be receptacles or hardwired connected to the load equipment.

The SmartSwitch consists of two modules, a fixed module containing the input and output connections and bypass switch with a compartment that holds the plug-in and removable electronics/switching module. **Figure 1** shows a typical one-line schematic diagram of the SmartSwitch.

Figure 1 Typical SmartSwitch One-Line Diagram

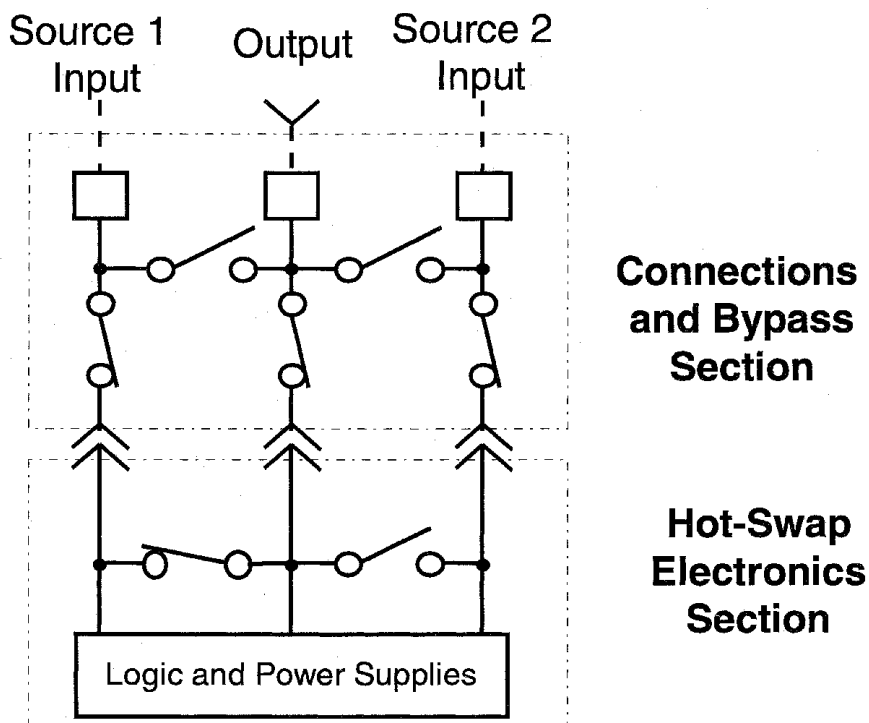

1.1 Specifications

1.1.1 General Specifications

- Manual and Automatic Transfers.
- Sense and Transfer Time: Less than 6 milliseconds.
- Break-Before-Make Switching.
- Selectable Preferred Source.
- Selectable Auto/Manual Retransfer.
- Retransfer Time Delay: 1 to 60 seconds adjustable.
- In-Phase Transfer Window: 1 to 20 degrees adjustable.
- Output Overload Transfer Inhibit: 1 to 10 times full load current adjustable.
- Programmable Switch Self Test.
- Convection Cooling.

1.1.2 Electrical Specifications

- Nominal input voltage
 - 120 or 208 volts single phase 2W+G, 60 Hz
 - 220, 230, or 240 volts single phase 2W+G, 50 Hz
 - 208/120 volts single phase 3W+G, 60 Hz
 - 208 volts three phase, 3W+G, 60 Hz
 - 208/120 volts three phase, 4W+G, 60 Hz
 - 380, 400, or 415 volts three-phase 3W+G, 50 Hz
 - 380/220, 400/230, or 415/240 volts three phase 4W+G, 50 Hz
 - Solidly grounded power sources
- Branch circuit breaker rating
 - 15, 20, 30, or 60 amps, 60 Hz
 - 13, 25, or 50 amps, 50 Hz
- Maximum continuous current
 - 12, 16, 24, or 48 amps, 60 Hz
 - 13, 25, or 50 amps, 50 Hz
- Load power factor range: 0.5 to 1.0, leading or lagging.
- Load crest factor: up to 3.5.
- Source voltage distortion: up to 10% THD.
- Overload capability: 125% of continuous current for 2 hours, 1000% for 2 cycles minimum.
- Overcurrent Protection: External overcurrent protection provided by the supply branch circuit breakers.
- Short circuit withstand capability: up to 20,000 symmetrical amps, protected by internal fusing.
- Withstands Transient Voltage Surges up to 6 kV as defined by IEEE C62.41 for Category A3.
- Meets FCC Part 15 Class A Emission Limits.
- ETL Listed under UL Standard 1008.
- 50 Hz units are CE marked for compliance with the EMC and Low Voltage Directives.
- Redundant Control Power Supplies.
- Integral Maintenance Bypass.
- Eight Isolated Normally Open, Form A Switch Status Contacts.
- RS-232 Communications Port
- Hot-Swap, Plug-In Electronics Module.

1.1.3 Environmental Specifications

- Storage temperature range: -40° to +60°C
- Operating temperature range: 0° to 40°C.
- Relative Humidity: 0 to 95% without condensation
- Operating Altitude: up to 5000 feet (1500 meters) above sea level without derating.
- Storage/Transport Altitude: up to 40,000 feet (12,000 meters) above sea level.
- Audible Noise: less than 45 dBA at 5 feet (1.5 meters).

Table 1 SmartSwitch™ Ratings

SS xxxxxxxx U 01									
<u>Product Family</u> SS = SmartSwitch		<u>Output Connector(s)</u> (See Table)		<u>Enclosure Type</u> U = Underfloor/Wallmount R = Rackmount			<u>Generation Code</u> 01 = Present		
Connector Designation	Receptacle	Voltage	No. of Conductors			OPD*		Enclosure	
			Phase	Neutral	Gnd	Poles	Amps	Type	Refer to
IBMA	3743	208	2	—	1	2	20	R	Figure 2
IBMB	3744	208	3	—	1	3	15	U	Figure 3
IBMC	3753	208	2	—	1	2	30	U	Figure 3
IBMD	3754	208	3	—	1	3	30	U	Figure 3
IBME	7324	208	3	—	1	3	60	U	Figure 3
420R9V	420R9V	208	3	—	1	3	20	U	Figure 3
460R9V	460R9V	208	3	—	1	3	60	U	Figure 3
515R2	5262	120	1	1	1	1	15	U	Figure 3
515R4	(2) 5262	120	1	1	1	1	15	R	Figure 2
520R2	5362	120	1	1	1	1	20	R	Figure 2
520R4	(2) 5362	120	1	1	1	1	20	R	Figure 2
530R1	9308	120	1	1	1	1	30	U	Figure 3
615R2	5662	208	2	—	1	2	15	R	Figure 2
620R2	5462	208	2	—	1	2	20	R	Figure 2
630R1	9330	208	2	—	1	2	30	U	Figure 3
1420R1	8410	120/208	2	1	1	2	20	U	Figure 3
1430R1	9430	120/208	2	1	1	2	30	U	Figure 3
1520R1	8420	208	3	—	1	3	20	U	Figure 3
L515R1	4710	120	1	1	1	1	15	R	Figure 2
L520R1	2310	120	1	1	1	1	20	R	Figure 2
L530R1	2610	120	1	1	1	1	30	U	Figure 3
L615R1	4560	208	2	—	1	2	15	R	Figure 2
L620R1	2320	208	2	—	1	2	20	R	Figure 2
L630R1	2620	208	2	—	1	2	30	U	Figure 3
L1420R1	2410	120/208	2	1	1	2	20	U	Figure 3
L1430R1	2710	120/208	2	1	1	2	30	U	Figure 3
L1520R1	2420	208	3	—	1	3	20	U	Figure 3
L1530R1	2720	208	3	—	1	3	30	U	Figure 3
L2120R1	2510	120/208	3	1	1	3	20	U	Figure 3
L2130R1	2810	120/208	3	1	1	3	30	U	Figure 3
FW120	None	120	1	1	1	1	20	R	Figure 2
FW130	None	120	1	1	1	1	30	U	Figure 3
FW220	None	208	2	—	1	2	20	R	Figure 2
FW230	None	208	2	—	1	2	30	U	Figure 3
FW230N	None	208/120	2	1	1	2	30	U	Figure 3
FW330	None	208	3	—	1	3	30	U	Figure 3
FW330N	None	208/120	3	1	1	3	30	U	Figure 3
FW360	None	208	3	—	1	3	60	U	Figure 3
FW113	None	230	1	1	1	1	13	R	Figure 2
FW325N	None	400/230	3	1	1	3	25	U	Figure 3
FW350	None	400	3	—	1	3	50	U	Figure 3

Consult Factory for other available connectors not shown.

* OPD - Maximum size of Overcurrent Protection Device (fuse or circuit breaker) supplying SmartSwitch.

2.0 UNPACKING AND INSTALLATION

A quality installation begins on the receiving dock.

Upon receipt and before unpacking, inspect the shipping container for damage or mishandling. If carton is damaged, note on shipper's receipt and check for concealed damage. If any damage as a result of shipping is observed, file a damage claim with the shipper within 24 hours and contact your local Liebert representative or Liebert Customer Service and Support at **1-800-543-2378** to inform them of the damage claim and the condition of the equipment.

If unit is to be stored before installation, it is recommended to store the unit in a dry environment with temperatures in the range of 0°C to 40°C. Use original packing materials or other suitable means to keep the unit clean. When opening the shipping carton, use care not to puncture the carton with sharp objects.

The unit is of a size and weight that it can be easily moved to its intended location. Refer to the unit dimensions shown in **Figure 2** and **Figure 3**. Typical unit weights are less than 70 pounds (32 kg) for the wall or underfloor enclosure and less than 40 pounds (18 kg) for the rackmount enclosure.

2.1 Location Considerations

The unit is designed to be installed indoors where the ambient air temperature is in the range of 0°C and 40°C with a relative humidity of 0% to 95% non-condensing.

The underfloor and wall mount enclosures are designed to withstand moderate amounts of moisture such as is normally available under a computer room raised floor. Do not operate the units in standing water.



CAUTION:

Do not locate or operate the unit in hazardous areas where there is conductive or explosive dust, flammable liquids or gases, or corrosive substances.

Altitude - The standard units are designed for full load operation up to 5000 feet (1500 meters) above sea level. For higher altitude applications, contact your local Liebert Representative or applications engineering.

Heat Output - The units produce minimal heat output during normal operation. The typical heat output, which should be included in any calculations for room heat load, is less than 260 BTU/ Hour (80 W/Hour).

Rackmount Installation - The rackmount enclosure is designed to fit into an EIA Standard 19 inch rack. For rackmount installation, support the unit on a shelf, bracket, or slide. Do not secure only by the front mounting plate. Secure the unit into the rack using four screws through the front plate. See **Figure 2**.

2.2 Input and Output Power Connections

All wiring should be installed by a qualified electrician. All wiring must comply with NEC and applicable local codes.



WARNING

RISK OF ELECTRICAL SHOCK. HAZARDOUS VOLTAGES ARE PRESENT INSIDE THE SMARTSWITCH. VERIFY THAT THE ALL INPUT POWER SOURCES ARE DE-ENERGIZED AND LOCKED OUT BEFORE MAKING CONNECTIONS INSIDE THE UNIT. THE SMARTSWITCH IS INTENDED TO BE FED FROM TWO SOURCES. BE SURE ALL SOURCES OF POWER ARE DE-ENERGIZED AND LOCKED OUT BEFORE MAKING CONNECTIONS INSIDE THE UNIT.



WARNING

RISK OF UNIT DAMAGE. THE SMARTSWITCH IS INTENDED TO BE OPERATED FROM SOLIDLY GROUNDED POWER SOURCES. OPERATION FROM OTHER THAN SOLIDLY GROUNDED POWER SOURCES MAY CAUSE MISOPERATION OR DAMAGE TO THE UNIT.

If the unit is not furnished with input power cables, then input power connections are made to terminal blocks located inside the unit. Refer to the unit outline drawings furnished with the unit or **Figure 2** and **Figure 3** for the location of the input power connections. Terminal blocks for switches rated 13 to 20 amps accept wires sizes of #14 to #10 AWG. Terminal blocks for switches rated 25 to 60 amps accept wire sizes of #12 to #6 AWG.

Wire Size AWG	Tightening Torque Lb.-in (N-m)
#14 - #10	20 (2.3)
#8	25 (2.9)
#6	35 (4.0)

Figure 2 Typical 15 to 20 Amp SmartSwitch Rackmount Unit

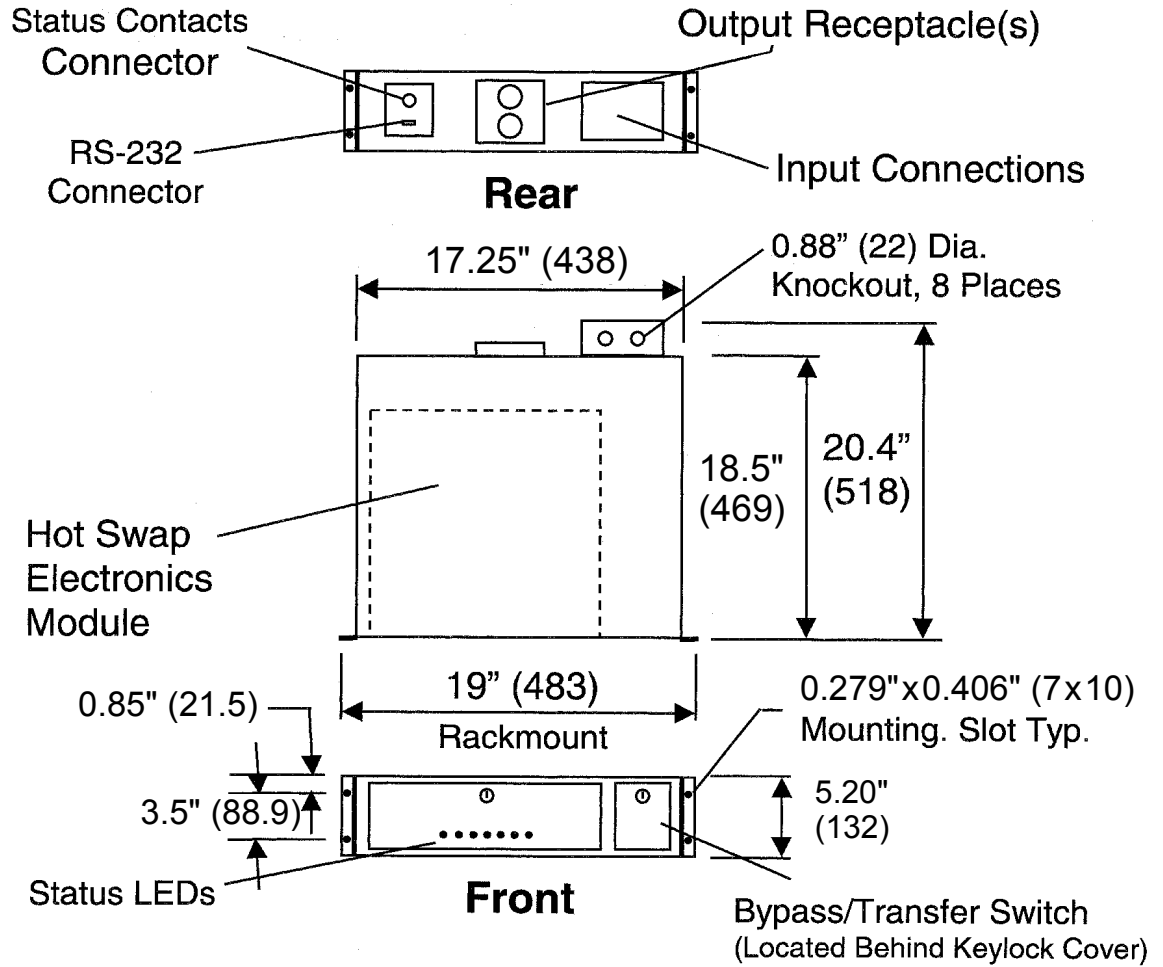

All dimensions are in inches (mm).

Figure 3 Typical 25 to 60 Amp SmartSwitch Underfloor / Wallmount Unit

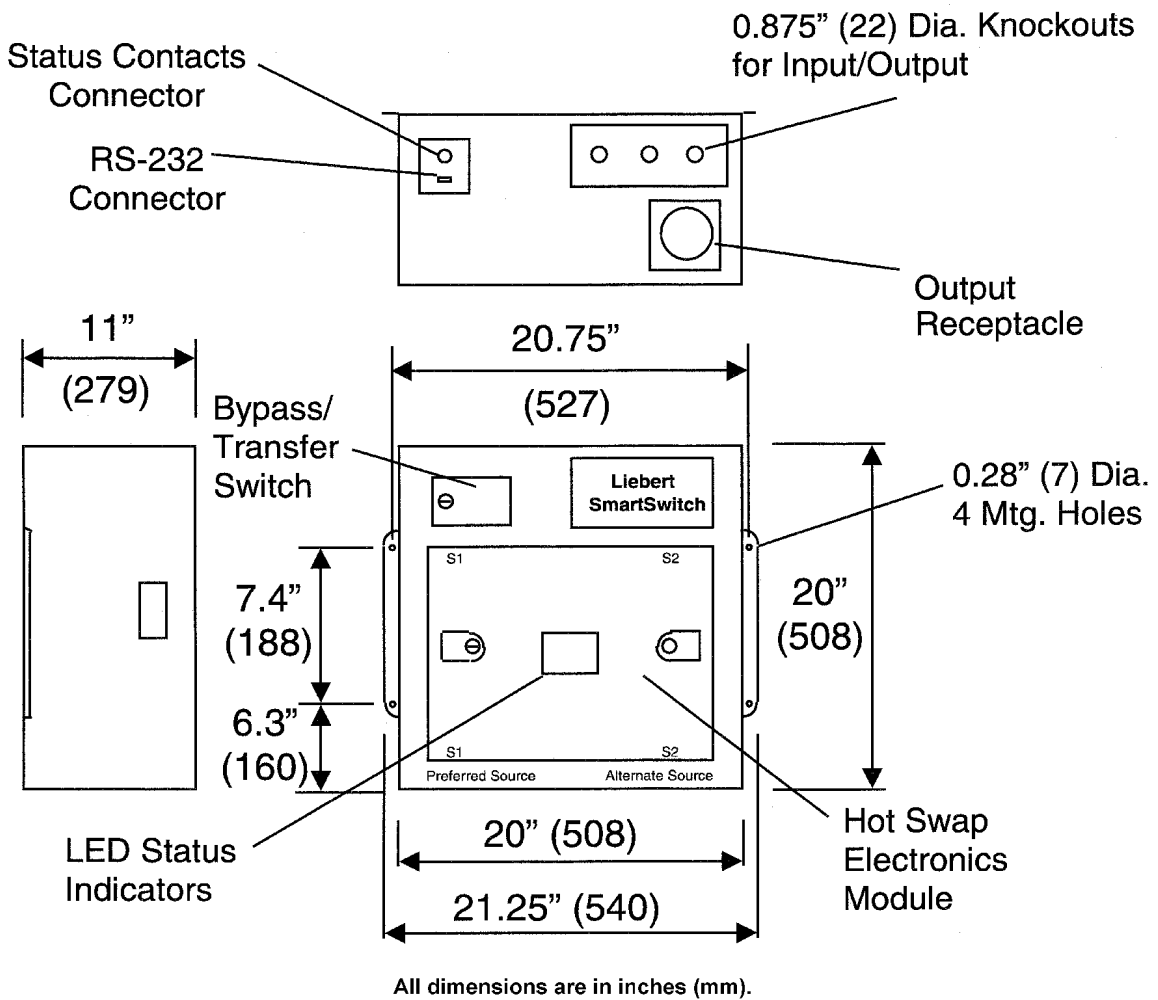

If the unit is furnished with input power cables, the input power connections are made to the receptacles matching the input power plugs furnished located in close proximity to the Smart-Switch (typically within 3 feet).

The input power connections to the SmartSwitch must include overcurrent protection included as part of the supply power distribution system. The maximum supply overcurrent protection for each SmartSwitch input should not exceed 125% of the rated continuous current or as indicated on the unit label. The maximum size overcurrent protection device (fuse or circuit breaker) for the particular SmartSwitch used is listed in the unit ratings table (see **Table 1**).

The nominal voltage and frequency of each input source must match the voltage rating indicated on the unit label. Failure to comply with this requirement may result in misoperation or damage to the unit.

Severe input voltage distortion or large ringing transients, such as those caused by utility capacitor switching, may be interpreted by the SmartSwitch as a source failure.

The SmartSwitch is intended to be supplied from two independent AC power sources to provide protection against a source failure.



NOTE

The two input sources need to be nominally of the same voltage level, frequency and phase rotation. To ensure virtually uninterrupted transfers between the two AC sources, the two input sources must be synchronized, typically within 5 to 15 electrical degrees. For single phase circuits, be sure to use the same phase from each input power source to maintain synchronized inputs to the SmartSwitch.

Figure 4 shows the typical input and output power connections to the SmartSwitch. The SmartSwitch can accept up to 3 phase conductors, a neutral conductor and an equipment grounding conductor per input and output to match the specified supply voltage configuration. See the unit ratings table (Table 1) for the required number of phase and neutral conductors required for the particular SmartSwitch used.

For example, for a NEMA 520R2 SmartSwitch application, one phase and neutral conductor and equipment grounding conductor per source are required whereas for a NEMA L1530R1 SmartSwitch application, three phase conductors and an equipment grounding conductor per source are required.

The output power connections can be to terminal blocks located inside the SmartSwitch (as shown in Figure 2, Figure 3, and Figure 4) or to receptacle(s) located on the SmartSwitch.

Figure 4 Typical Input and Output Power Connections

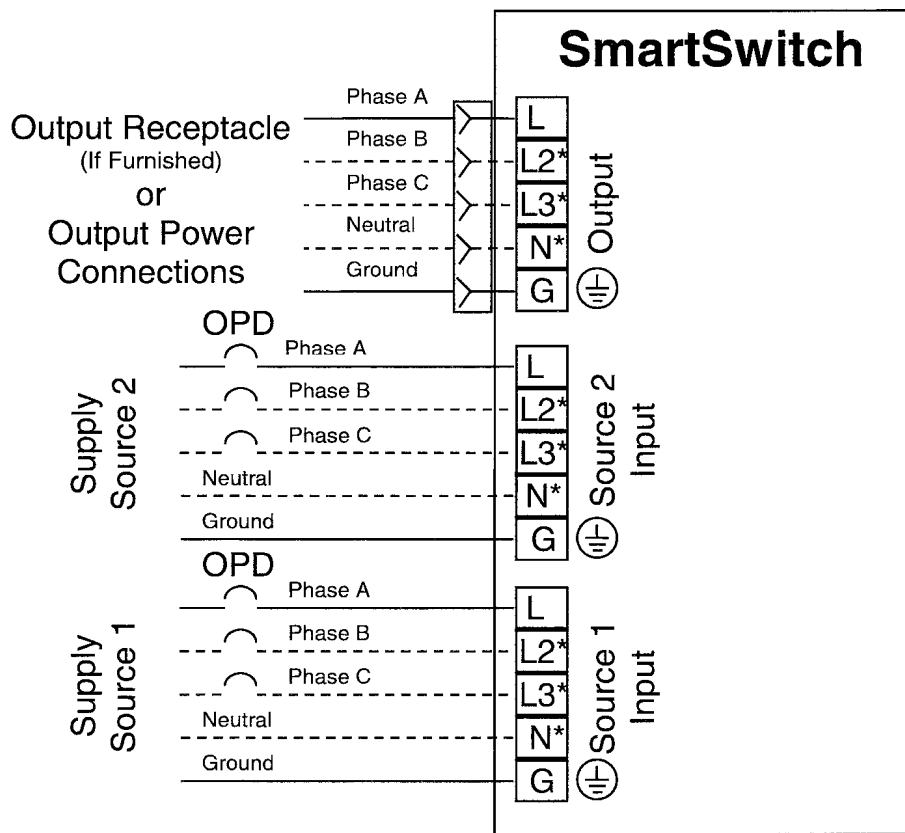

OPD – Supply Overcurrent Protection Device; Fuse or Circuit Breaker. Connections to L2, L3 or N depend on unit voltage rating.

See Unit Ratings Table.

Terminals marked  must be connected to the protective earthing (equipment grounding) conductor associated with the supply and output wiring.

2.3 Grounding

Proper, NEC-specified equipment grounding is required for safety purposes. An insulated equipment grounding conductor is recommended to be run with each input and output power connection. The equipment grounding conductors should be at least the minimum size conductor per NEC Table 250-95 based on the supply overcurrent protection device.

If conduit or other wireway is used as the grounding means, adequate electrical continuity must be maintained at all conduit connections. The use of isolating bushings with a metal conduit can be a safety hazard and is not recommended.

In accordance with the NEC, only one equipment grounding system may be used in a single building. As such, both input power sources should be referenced to a common building grounding electrode system. The SmartSwitch input equipment grounding conductors should not be the only grounding interconnection between the two input power sources.

The SmartSwitch switches all input phase and neutral conductors to maintain complete isolation of the two input power sources. A common neutral-to-ground bond for the two input sources is not required for proper operation but is recommended to avoid potential common mode disturbances when source transfers are made.

2.4 Control Wiring Connections

The SmartSwitch includes relay output contacts and RS-232 communications port for remote indication of switch status. **Figure 2** and **Figure 3** show the typical locations of the control connectors. **Figure 5** shows the typical control connections. Refer to **3.3 - RS-232 Communications Port** for RS-232 communication port description.

To facilitate connection to the relay contacts, the mating connector with short pigtailed wires is supplied with the SmartSwitch. Relay contact ratings are 1 amp, 125 VAC or 30 VDC maximum. Contacts close on the indicated switch condition. The relays are located in the removable electronics module. Contacts are not operational with the electronics module removed.

Figure 5 Control Wiring Connections

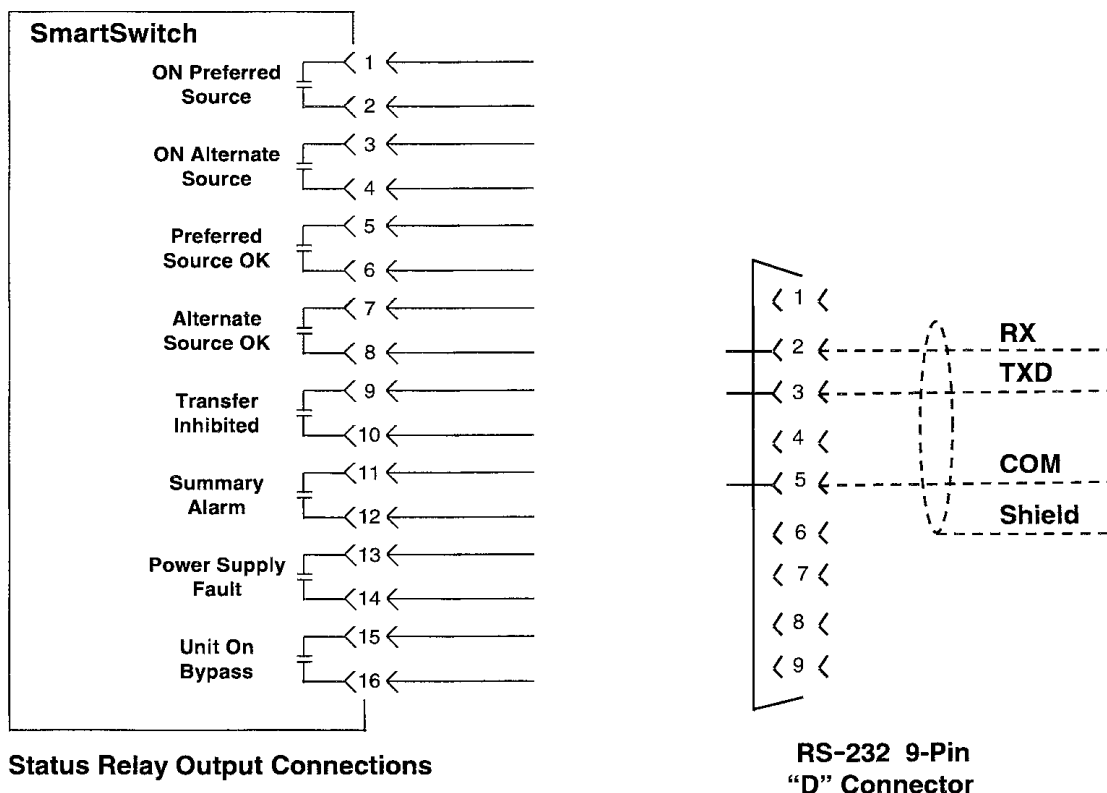

3.0 OPERATING INSTRUCTIONS



NOTE

Read the entire operating instructions section before placing the SmartSwitch into operation.



NOTE

For continued protection against a source failure, periodic testing of the SmartSwitch is recommended. For manual testing, see the transfer control instructions.

3.1 Description of SmartSwitch Operation

The SmartSwitch™ is an automatic transfer switch designed to provide fast automatic transfers between two independent, synchronous AC power sources to provide continuity of AC power to critical equipment, such as information technology equipment. One of the two AC inputs is designated as the “preferred” source to which the SmartSwitch will connect the load as long as the designated input source is within acceptable voltage limits. If the preferred source falls outside the acceptable limits, the SmartSwitch is designed to transfer the output load to the other “alternate” input source, as long as the alternate source is within acceptable voltage limits and is synchronized with the preferred source within the selected phase synchronization window. The SmartSwitch provides fast, break-before-make transfers to prevent interconnection of the two sources, even under faulted source conditions. The maximum sense and transfer times are within the tolerance of the IEEE Standard 446 susceptibility curve for information technology equipment to allow uninterrupted load equipment operation. To prevent the transfer of a output overload or fault condition, the SmartSwitch automatically disables transfers to the alternate source if the output current exceeds preset limits.

The SmartSwitch™ consists of two modules, a fixed module containing the input and output connections and bypass/transfer control switch, and a plug-in, removable electronics/switching module. The bypass/transfer control switch is located behind a keylocked, hinged access cover to restrict access to qualified or designated operators. The plug-in module likewise contains keylocked latches to prevent unauthorized removal of the module. The SmartSwitch is designed to allow replacement of the removable electronics/switching module without having to de-energize the load equipment. See the bypass, transfer control, and module replacement instructions for more information.

3.2 Status Indicators

The SmartSwitch contains seven long-life, status indicators located on the removable electronics module to indicate the unit and source status. See **Table 2** for a listing of the status indicators and their definitions. The status indicators are active as long as the removable module is in place and at least one of the two input sources is energized.

Table 2 SmartSwitch Status Indicators

Indicator	Description
ON PREFERRED SOURCE	The output load is connected to the preferred source.
ON ALTERNATE SOURCE	The output load is connected to the alternate source.
PREFERRED SOURCE OK	All phases of the preferred source are within voltage limits.
ALTERNATE SOURCE OK	All phases of the alternate source are within voltage limits.
TRANSFER INHIBITED	Automatic transfer is inhibited. Reasons for transfer (or retransfer) inhibit include both sources are not available, sources are not synchronized, or the output load has exceeded the preset limit.
SUMMARY ALARM	The SmartSwitch has detected a fault condition. If both sources are available and synchronized, then the alarm may indicate a SmartSwitch failure.
ON BYPASS	The bypass/transfer switch is in the bypass position.
S1 PREFERRED*	Source 1 is selected as the preferred source.
S2 PREFERRED*	Source 2 is selected as the preferred source.

*These LED indicators are only provided on the rackmount units.

3.3 RS-232 Communications Port

The SmartSwitch contains an RS-232 ASCII communications port for changing user settings and remote monitoring of unit status and alarm information. The RS-232 port connections are to a 9-pin “D” connector located on the outside of the unit. See **Figure 2** and **Figure 3** for the location of the port and **Figure 5** for the port connections.

The default parameters of the communications port are RS-232 terminal emulator protocol using EIA voltage levels, ASCII Characters, Half Duplex Asynchronous Communications, 9600 Baud rate, 8 Data Bits, 1 Stop Bit, No Parity, No Handshaking, and <CR> Terminator.

The port uses a query-response format. Commands are divided into two groups, inquiries and settings changes. The list of available customer commands is shown in **Table 3**. Only one command is serviced at a time. A password is required to change unit settings. The default password is “Liebert.” Inquiries include viewing unit status, viewing event history log, and viewing settings. Typical inquiry responses are shown in **Table 4**, **Table 5**, and **Table 6**.

The Event Log contains the last 175 switch events. The Settings Log contains the last 50 switch settings changes.

Table 3 RS-232 ASCII Communication Port Customer Commands

Function	Command	Selections
View Status	Y<CR>	
View Event Log	B<CR>	Views up to the last 175 switch events
View Settings	O<CR>	
Set Time*	Thh:mm:ss<CR>	hh = hours, mm = minutes, ss = seconds
Set Date*	Dmm/dd/yy<CR>	mm = month, dd = day, yy = year
Synchronization Window*	Pn<CR>	n = 1 to 20 degrees
Auto Retransfer Enable*	Rx<CR>	x = 0 for disabled, x = 1 for enabled
Auto Retransfer Delay*	En<CR>	n = 1 to 60 seconds
Load Current Transfer Inhibit*	In<CR>	n = 1 to 10 times full load current
Load Current Inhibit Reset*	Hx<CR>	x = 0 for Manual, x = 1 for Automatic
Auto Transfer Test Enable*	Sx<CR>	x = 0 for disabled, x = 1 for enabled
Auto Transfer Test Settings*	Xmm/dd/yy hh:mm:ss n<CR>	mm/dd/yy = test date, hh:mm:ss = test time, n = 1 to 365 days between tests
Restore Default Settings*	W<CR>	
Clear Event Log*	G<CR>	
View Settings Log	C<CR>	Views up to the last 50 switch settings changes
Clear Settings Log*	Z<CR>	

*User Password required for these commands. System prompts for password entry. Password remains valid for 2 minutes after each password-required command.

Table 4 Example View Status Response

ALARMS
Power Supply Fault
SOURCE and SWITCH
Load on Preferred Source
Switch in Normal Mode
Preferred Source Available
Alternate Source Available

Alarms include:

Preferred Source Fail, Alternate Source Fail, Out of Sync, Transfer Inhibit, Peak Overload, Transfer Test Failed, and Power Supply Fault.

Source and Switch Messages include:

Load on Preferred Source, Load on Alternate Source, Switch in Normal Mode, Manual Transfer to S1, Manual Transfer to S2, Bypass to S1, Bypass to S2, Preferred Source Available, and Alternate Source Available.

Table 5 Example View Event Log Response

DATE	TIME	DESCRIPTION
10/21/97	16:34:39	Transferred to Preferred
10/21/97	16:34:39	Transfer Test Passed
10/21/97	16:34:39	Transferred to Alternate
10/21/97	16:34:38	Transfer Test Initiated
10/21/97	16:34:38	Alternate Source Available
09/27/97	07:22:11	In Sync
09/27/97	07:21:08	Out of Sync
06/01/97	02:10:32	Transferred to Preferred
06/01/97	02:10:29	Preferred Source Available
06/01/97	01:29:13	Transferred to Alternate
06/01/97	01:29:13	Preferred Source Fail

Logged Events include:

Preferred Source Fail
Preferred Source Available
Alternate Source Fail
Alternate Source Available
Out of Sync
In Sync
Peak Overload
Peak Overload Gone
Transfer Inhibit
OK to Transfer
Power Supply Fault
Power Supply OK
Switch in Normal Mode
Manual Transfer to S1
Manual Transfer to S2
Bypass to S1
Bypass to S2
Transferred to Alternate
Transferred to Preferred
Transfer Test Initiated
Transfer Test Pended
Transfer Test Passed
Transfer Test Failed

Table 6 Example View Settings Response

CURRENT SETTINGS:	
System Time:	10/21/97 16:23:54
Nominal Voltage:	120
Amps:	24
Frequency:	60
Phase:	1
Neutral:	YES
Unit Type:	UNDERFLOOR
Sync Window:	10
Auto Retransfer:	ENABLED
Retransfer Delay:	5
Current Inhibit:	5
Inhibit Type:	MANUAL
Transfer Test:	ENABLED
Next Test:	10/01/97 23:59:58
Test Interval:	90
Preferred Source	S1

4.0 OPERATOR CONTROLS

4.1 Bypass/Transfer Control Switch

The SmartSwitch is furnished with a Bypass/Transfer Control switch. The switch is located behind the hinged, keylocked cover. **Figure 6** shows the switch positions.

Normal Mode. The switch should be left in the “Normal” position for automatic transfer control. Automatic transfer control is inhibited in all switch positions other than the “Normal” position. In the “Normal” position, the switch will connect the load to the preferred source as long as the preferred source is available. If the preferred source falls outside of the designated limits while the switch is in the “Normal” position and the alternate source is available and synchronized, the SmartSwitch will automatically transfer the load to the alternate source. To disable automatic transfers, place the Bypass/Transfer Control switch in any position other than “Normal.”

Man. Xfer S1. Placing the Bypass/Transfer Control switch in the “Man. Xfer S1” position commands the SmartSwitch to transfer the load to source 1. If the load is already connected to source 1, automatic transfers to source 2 will be disabled. If the load is connected to source 2, placing the switch in this position requests the SmartSwitch to transfer the load to source 1. The SmartSwitch will transfer the load to source 1 if source 1 is available and synchronized to source 2. The SmartSwitch will automatically delay transfer to source 1 until source 1 is available and within the preset phase synchronization window.

Man. Xfer S2. Placing the Bypass/Transfer Control switch in the “Man. Xfer S2” position commands the SmartSwitch to transfer the load to source 2.

If the load is already connected to source 2, automatic transfers to source 1 will be disabled. If the load is connected to source 1, placing the switch in this position requests the SmartSwitch to transfer the load to source 2. The SmartSwitch will transfer the load to source 2 if source 2 is available and synchronized to source 1. The SmartSwitch will automatically delay transfer to source 2 until source 2 is available and within the preset phase synchronization window.

Bypass to S1. Placing the Bypass/Transfer Control switch in the “Bypass to S1” position bypasses the electronics and switching module and connects the load to source 1 by way of the bypass switch. In this position, control power is still available in the electronics module to allow the bypass status indicator to remain active. All other indicators, such as source available indicators, are not active in the bypass position. **To avoid loss of power to the load, do not rotate the switch to the “Bypass to S1” position unless the load is connected to source 1 (and source 1 is available) when the switch is in the “Man. Xfer to S1” position.**

Bypass to S2. Placing the Bypass/Transfer Control switch in the “Bypass to S2” position bypasses the electronics and switching module and connects the load to source 2 by way of the bypass switch. In this position, control power is still available in the electronics module to allow the bypass status indicator to remain active. All other indicators, such as source available indicators, are not active in the bypass position. **To avoid loss of power to the load, do not rotate the switch to the “Bypass to S2” position unless the load is connected to source 2 (and source 2 is available) when the switch is in the “Man. Xfer to S2” position.**

Figure 6 Bypass / Transfer Control Switch

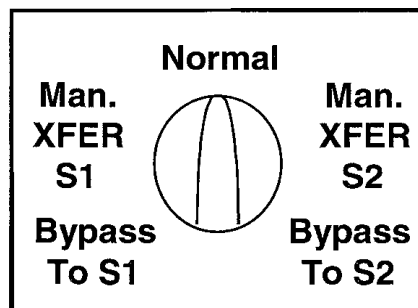

5.0 OPERATING GUIDELINES

After installation, the following operating guidelines can be used for standard equipment operation. These guidelines should be reviewed for any special equipment modifications, special site conditions, or company policies that may require changes to these operating guidelines.

Initial System Turn-On. After the initial installation, equipment relocation, or extended period of inoperation, perform the initial system checkout. Have an electrician or other qualified electrical service person verify that the unit has been properly installed and connected to the input sources, including having the proper supply overcurrent protection and having the required quantity and size of input and output conductors based on the unit rating. Verify that both input power sources have a nominal voltage and frequency that match the unit rating. Verify that the two input power sources are synchronized. With load disconnected or turned off, and the Bypass/Transfer Control switch is in the “Normal” position, apply power to one of the SmartSwitch inputs. Verify that the SmartSwitch recognizes that the source is available and transfers to that source. Apply power to the second input and verify that the SmartSwitch recognizes that source is available, the transfer inhibit indicator is OFF, and transfers to the preferred source. Use the normal operating procedures to verify proper SmartSwitch operation in all modes before connecting the load equipment. Failure of the SmartSwitch to operate properly may be due to installation errors, the power sources not being synchronized or otherwise compatible with the SmartSwitch ratings, or SmartSwitch failure. For assistance contact Liebert Global Services (in the U.S., **1-800-LIEBERT**) or your local Liebert sales representative. After verifying proper SmartSwitch operation in all modes, connect the load equipment and verify proper load operation in all SmartSwitch operating modes.

After completing the initial system Turn-On, refer to the following operational guidelines for standard equipment operation.

Normal System Turn-On. The SmartSwitch can be started with either or both input power sources available and the Bypass/Transfer Control switch in any position. If the Bypass/Transfer Control switch is not in the “Normal” position, refer to the instructions pertaining to that position of the switch to return the Bypass/Transfer Control switch to the “Normal” position. If the Bypass/Transfer Control switch is in the “Normal” position, the SmartSwitch will automatically transfer the load to whichever source is first available. If both sources are available and synchronized, the SmartSwitch will transfer the load to the designated preferred source. For automatic source failure protection, the Bypass/Transfer Control switch must be in the “Normal” position.

Manual Transfer to Source 1. Rotating the Bypass/Transfer Control switch to the “Man. XFER S1” position initiates a manual transfer to source 1. If the load is not currently connected to source 1, the SmartSwitch will transfer the load to source 1 if source 1 is available and synchronized. If the load is connected to source 1, the SmartSwitch will keep the load connected to source 1, even if source 1 fails. The “Man. XFER S1” position is intended to be used for test transfer purposes and to ensure that the load is connected to source 1 before bypassing to source 1.

Manual Transfer to Source 2. Rotating the Bypass/Transfer Control switch to the “Man. XFER S2” position initiates a manual transfer to source 2. If the load is not currently connected to source 2, the SmartSwitch will transfer the load to source 2 if source 2 is available and synchronized. If the load is connected to source 2, the SmartSwitch will keep the load connected to source 2, even if source 2 fails. The “Man. XFER S2” position is intended to be used for test transfer purposes and to ensure that the load is connected to source 2 before bypassing to source 2.

Bypass to Source 1. From the “Normal” position, rotate the Bypass/Transfer Control switch to the “Man. XFER S1” position to initiate transfer of the load to source 1. Use the indicator lights to verify that source 1 is available and the load is connected to source 1 before rotating the Bypass/Transfer Control switch to “Bypass To S1” position. If source 1 is not available and the load is not connected to source 1 before the switch is rotated to the “Bypass To S1” position, power to the load may be interrupted. If the load is connected to source 2 and the SmartSwitch will not transfer the load to source 1, initiate a bypass to source 2.

Bypass to Source 2. From the “Normal” position, rotate the Bypass/Transfer Control switch to the “Man. XFER S2” position to initiate transfer of the load to source 2. Use the indicator lights to verify that source 2 is available and the load is connected to source 2 before rotating the Bypass/

Transfer Control switch to “Bypass To S2” position. If source 2 is not available and the load is not connected to source 2 before the switch is rotated to the “Bypass To S2” position, power to the load may be interrupted. If the load is connected to source 1 and the SmartSwitch will not transfer the load to source 2, initiate a bypass to source 1.

System Shutdown. Power to both SmartSwitch inputs must be turned OFF to ensure system shutdown.

Transfer Test. For continued protection against the SmartSwitch failure, periodic transfer testing of the SmartSwitch is recommended.

For manual transfer test, with both input sources available and synchronized (no Summary Alarm present), rotate the Bypass/Transfer Control switch from the “Normal” to “Man. XFER S1” or “Man. XFER S2” positions (whichever is the alternate source) and observe proper switch transfers (observe change in “On Preferred Source” and “On Alternate Source” indicator lights). Return Bypass/Transfer Control switch to the “Normal” position and after the retransfer delay, observe proper switch transfer back to the preferred source (observe change in “On Alternate Source” and “On Preferred Source” indicator lights).

For automatic (programmable) transfer testing, see the RS-232 communications port information in **3.3 - RS-232 Communications Port**.

Preferred Source Selection. The SmartSwitch allows either input source to be designated as the preferred source to which the load is transferred to and remains transferred to as long as the source remains available.

For 13 to 20 amp units in the rackmount enclosure (see **Figure 2**), to change the preferred source, place the unit in bypass to either input source, following the bypass procedure. Unlock and the removable electronics module. Slide out (remove) the electronics module from the main enclosure. Rotate the Preferred Source selector switch located on the rear of the electronics module to the desired preferred source. Re-insert the electronics module in the main unit completely and lock the electronics module.

On 25 to 60 amp units in the wall-mount and underfloor enclosure (see **Figure 3**), the preferred source is indicated by labeling on the top of the unit. To change the preferred source, place the unit in bypass to either input source, following the bypass procedure. Unlock and unlatch the two latches on the removable electronics module. Remove the electronics module from the main enclosure. Rotate the electronics module and re-insert in the main unit. Re-latch and lock the two latches on the electronics module. Verify that the labeling on the top of the unit indicates that the desired source is the preferred source.

6.0 MAINTENANCE



WARNING

THERE ARE NO USER-SERVICEABLE PARTS INSIDE THE REMOVABLE ELECTRONICS MODULE. OPENING OR REMOVING THE COVER OF THE REMOVABLE ELECTRONICS MODULE MAY EXPOSE HAZARDOUS VOLTAGES, EVEN WHEN THE SMARTSWITCH IS IN BYPASS. DO NOT ATTEMPT TO SERVICE THIS PRODUCT YOURSELF. REFER ALL SERVICING TO QUALIFIED SERVICE PERSONNEL.



CAUTION

The unit is supplied by two power sources. Unit may be electrically live if either of the two input sources is ON, even when the electronics module is removed. Lethal voltages exist inside the unit. Turn OFF and lock out BOTH input power sources before removing covers or working inside.

Minimal periodic maintenance of the SmartSwitch is required in normal operation. For assurance of continued protection against SmartSwitch failure, periodic transfer testing of the Smart Switch is recommended. For manual transfer tests, refer to the transfer test information in the operating guidelines section of this manual. For automatic transfer tests at programmed intervals, see the RS-232 communication port information in the operating instructions in **3.3 - RS-232 Communications Port**.

The SmartSwitch includes a replaceable electronics module. To replace the electronics module, follow the unit bypass instructions and place the unit on bypass to the source that is currently supplying the load. Unlock and unlatch the electronics module. Slide the electronics module out of the SmartSwitch. Replace the module with a module having the same part number or approved equivalent. Failure to use the approved replacement module may result in misoperation or damage to the SmartSwitch.

Monitoring of the SmartSwitch status (such as by way of the status relay output) is strongly recommended to allow detection of source failures or SmartSwitch failures before loss of power to the load. A summary alarm in the absence of any source failure or transfer inhibit alarm generally indicates a SmartSwitch failure. Prompt action to identify and correct the situation is recommended to prevent loss of power to the load.

Even the most reliable equipment can fail. For information or repair assistance, contact your local Liebert representative or Liebert Global Services. To contact Liebert Global Services in the U.S., call **1-800-LIEBERT**.



SmartSwitch™

Automatic Transfer Switch

Technical Support

U.S.A.	1-800-LIEBERT
Outside the U.S.A.	+614-841-6755 or 1-800-222-5877
U.K.	+44 (0) 1628 403200
France	+33 (0) 1 43 60 01 77
Germany	+49 89 99 19 220
Italy	+39 2 98250 1
Netherlands	+31 (0) 475 503333
Web site	http://www.liebert.com
Worldwide FAX tech support	+614-222-5877 option #4

The Company Behind The Products

With more than 500,000 installations around the globe, Liebert is the world leader in computer protection systems. Since its founding in 1965, Liebert has developed a complete range of support and protection systems for sensitive electronics:

- Environmental systems: close-control air conditioning from 1.5 to 60 tons.
- Power conditioning and UPS with power ranges from 250 VA to more than 1000 kVA.
- Integrated systems that provide both environmental and power protection in a single, flexible package.
- Monitoring and control — on-site or remote — from systems of any size or location

Service and support, through more than 100 service centers around the world, and a 24-hour Customer Response Center.

While every precaution has been taken to ensure accuracy and completeness of this literature, Liebert Corporation assumes no responsibility, and disclaims all liability for damages resulting from use of this information or for any errors or omissions.

© 2000 Liebert Corporation. All rights reserved throughout the world. Specifications subject to change without notice.

® Liebert and the Liebert logo are registered trademarks of Liebert Corporation. All names referred to are trademarks or registered trademarks of their respective owners.

Printed in U.S.A.

SL-20320