



**DISCONTINUED
PRODUCT**

POWER AVAILABILITY

MOMENTARY POWER-TIE CONFIGURATION

USER MANUAL

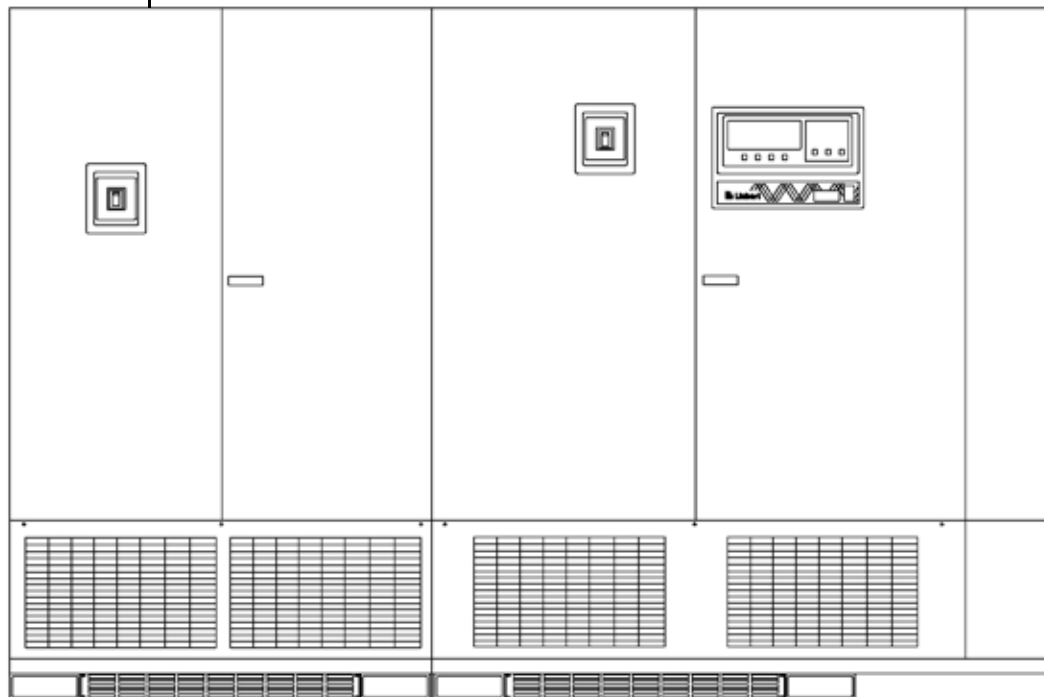

*Series 610
Multi-Module UPS*



**DISCONTINUED
PRODUCT**

TABLE OF CONTENTS

1.0	SYSTEM DESCRIPTION	1
1.1	Function	1
1.2	System Flexibility	1
1.3	Inter-System Isolation and Reliability	1
1.4	Control System Features	5
1.5	Operational Description	5
1.5.1	Operational Choices	5
1.5.2	Momentary Tie Operation	6
1.5.3	Tie System Components	7
1.5.4	Modes of Operation	8
2.0	OPERATION DESCRIPTION	10
2.1	Load Transfers Between UPS Systems	10
2.2	Design Criteria	12
2.3	Improper User Operation	15
2.4	Tie Circuit Breaker or Logic Faults	16
2.4.1	What Happens If a Failure Occurs During a Power Transfer	16
2.4.2	What Happens If a Logic Failure Occurs During Power Transfer	16
2.4.3	Hardware Failures	16
2.5	Recommendations - Tie Circuit Breaker Selection	16
3.0	CONTROL PANEL DESCRIPTION	17
3.1	Mimic Panel	17
3.2	Load Transfer Controls	18
3.3	Control Inhibits	19
3.4	Manual Controls	20
4.0	OPERATING INSTRUCTIONS	21
4.1	Initial System Start-Up	21
4.2	Basic Operation	21
4.2.1	Momentary Tie - Load Transfers	21
4.2.2	Normal Transfer Operation Configurations	21
4.2.3	Maintenance Procedures - Isolating Each UPS System	21
4.2.4	Isolating a UPS System for Maintenance - Combined Loads Operation	22
4.2.5	Transfer of Load Between Two Systems	22
4.2.6	Returning an Isolated System to Normal Operation - End Combined Loads Operation	23
4.2.7	Maintenance Procedures - Maintaining Power-Tie Components	23
4.2.8	Maintenance Procedures - Tie Control Logic Components	23
4.2.9	Abnormal Operations	24
4.2.10	Trouble Recovery	24
4.2.11	Isolation for Maintenance	24
4.2.12	Operation Scenarios/Transfer Procedures	26

FIGURES

Figure 1	Basic Dual-Bus Power-Tie one-line diagram	2
Figure 2	Power-Tie systems - fault isolation issues	3
Figure 3	Power-Tie systems - control interface diagram	4
Figure 4	Power-Tie system one-line diagram	9
Figure 5	Control panel layout	11
Figure 6	Power-Tie system - fault isolation issues	13
Figure 7	Power-Tie systems - fault tolerance	14
Figure 8	Power-Tie system one-line diagram	25
Figure 9	From start-up to normal operation, loads to be split between two distribution feeders	26
Figure 10	From combined loads operation to loads split between two feeders	26
Figure 11	Transfer both load feeders to one UPS	27
Figure 12	Both feeders on one system to normal operation	27
Figure 13	Transfer 100% load on one system to 100% load on a second system (a two-step operation) . . .	27
Figure 14	One system in bypass to both feeders combined on remaining operational system	28

1.0 SYSTEM DESCRIPTION

1.1 Function

The Liebert Momentary Power-Tie™ system provides manually initiated, uninterrupted transfers of a critical load bus between the two UPS Systems.

This topology permits one UPS and its associated distribution system to be shut down for maintenance while the load continues to be supplied by another UPS, without the necessity of transferring the load to bypass during shutdown or restart of the UPS being maintained.

1.2 System Flexibility

When the off-line (whether for maintenance or repair) modules are brought on-line again, the two UPS critical buses are again separated without the need to transfer to the bypass source. For momentarily tied systems, module kVA and kW ratings must be identical.

1.3 Inter-System Isolation and Reliability

For multiple UPS installations at a single site, best total system reliability is achieved when system-to-system independence is maximized. However, to transfer loads or parallel critical buses between multiple UPS systems, a certain amount of cross-connected system-to-system power and signal conductors are required. See **Figure 2**.

Proper implementation of power conductor runs and circuit breaker placement will minimize the risk that a catastrophic critical bus fault (e.g., a dropped wrench) on one system will cause a failure in a second system.

Liebert has minimized the risk of system-to-system electrical noise susceptibility and faults in system-to-system copper wire control circuitry through the use of fiber-optic technology as well as transformer and impedance isolation techniques in critical control circuits.

The possibility of signal and ground loops through control interconnections has been eliminated by isolating all control signals between each UPS system and the Tie Controls (See **Figure 3**). For example, a water leak over one UPS could effectively short all the control conductors together, causing a catastrophic fault in one system. Through the noted isolation techniques, this fault will not be propagated through intersystem (e.g., load sharing control conductors) control wiring to the second system.

Figure 1 Basic Dual-Bus Power-Tie one-line diagram

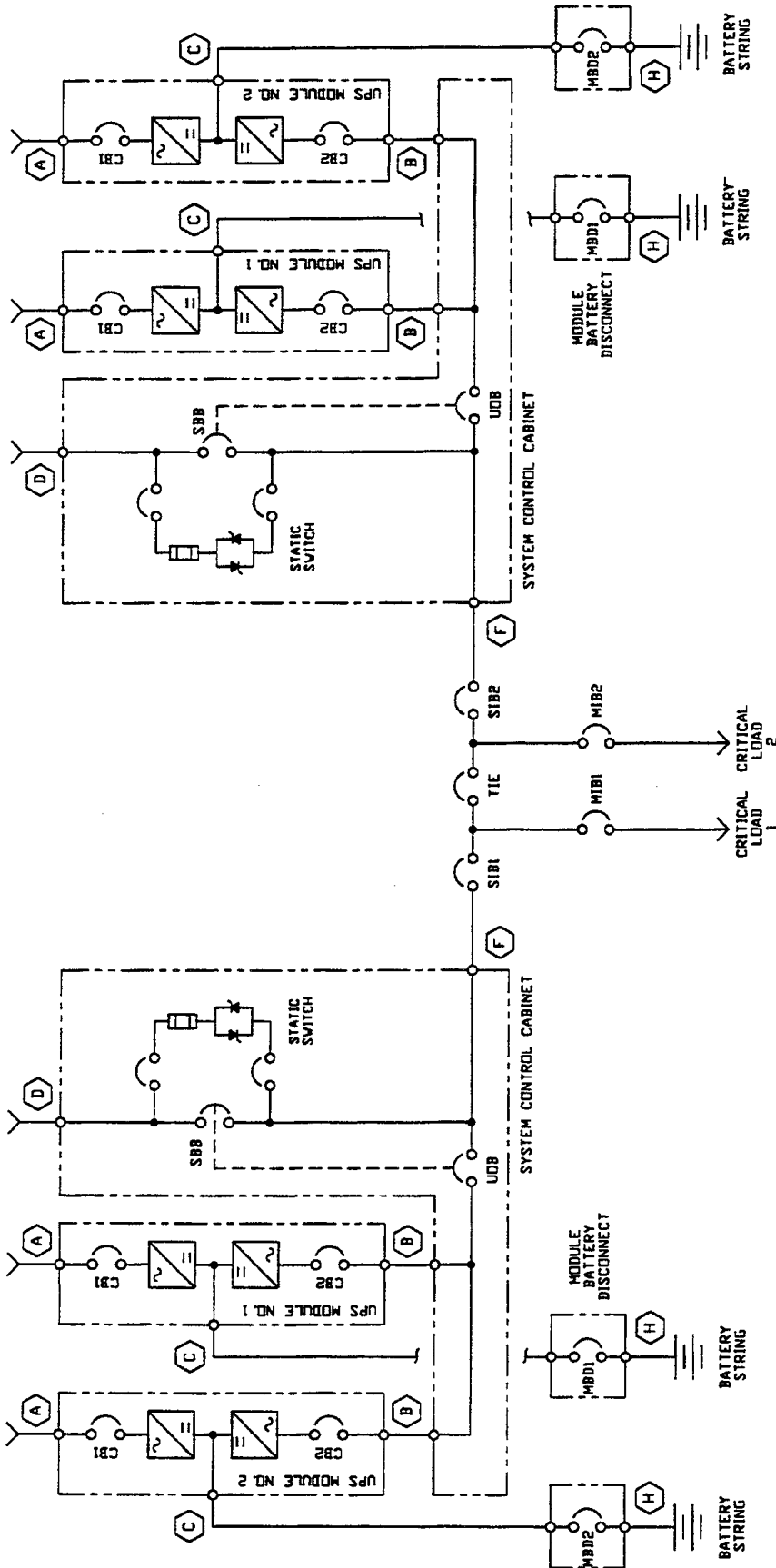

- (A) RECTIFIER AC INPUT
- (B) UPS MODULE AC OUTPUT
- (C) UPS MODULE DC INPUT
- (D) SYSTEM CONTROL CABINET AC INPUT
- (E) UPS SYSTEM AC OUTPUT
- (F) CRITICAL BUS AC OUTPUT
- (G) MODULE BATTERY DISCONNECT TO BATTERY STRING
- (H) MODULE BATTERY DISCONNECT TO BATTERY STRING

		TITLE ONE - LINE DIAGRAM POWER TIE SYSTEM	
DRG. NO. RC022241	DATE 02/22/94	ORDER NO.	

Figure 2 Power-Tie systems - fault isolation issues



HOW TO PROVIDE INTER-SYSTEM SIGNAL ISOLATION

- (A) RECTIFIER AC INPUT
- (B) UPS MODULE AC OUTPUT
- (C) UPS MODULE DC INPUT
- (D) SYSTEM CONTROL CABINET AC INPUT
- (E) UPS SYSTEM AC OUTPUT
- (F) CRITICAL BUS AC OUTPUT
- (G) MODULE BATTERY DISCONNECT TO BATTERY STRING
- (H) MODULE BATTERY DISCONNECT TO BATTERY STRING

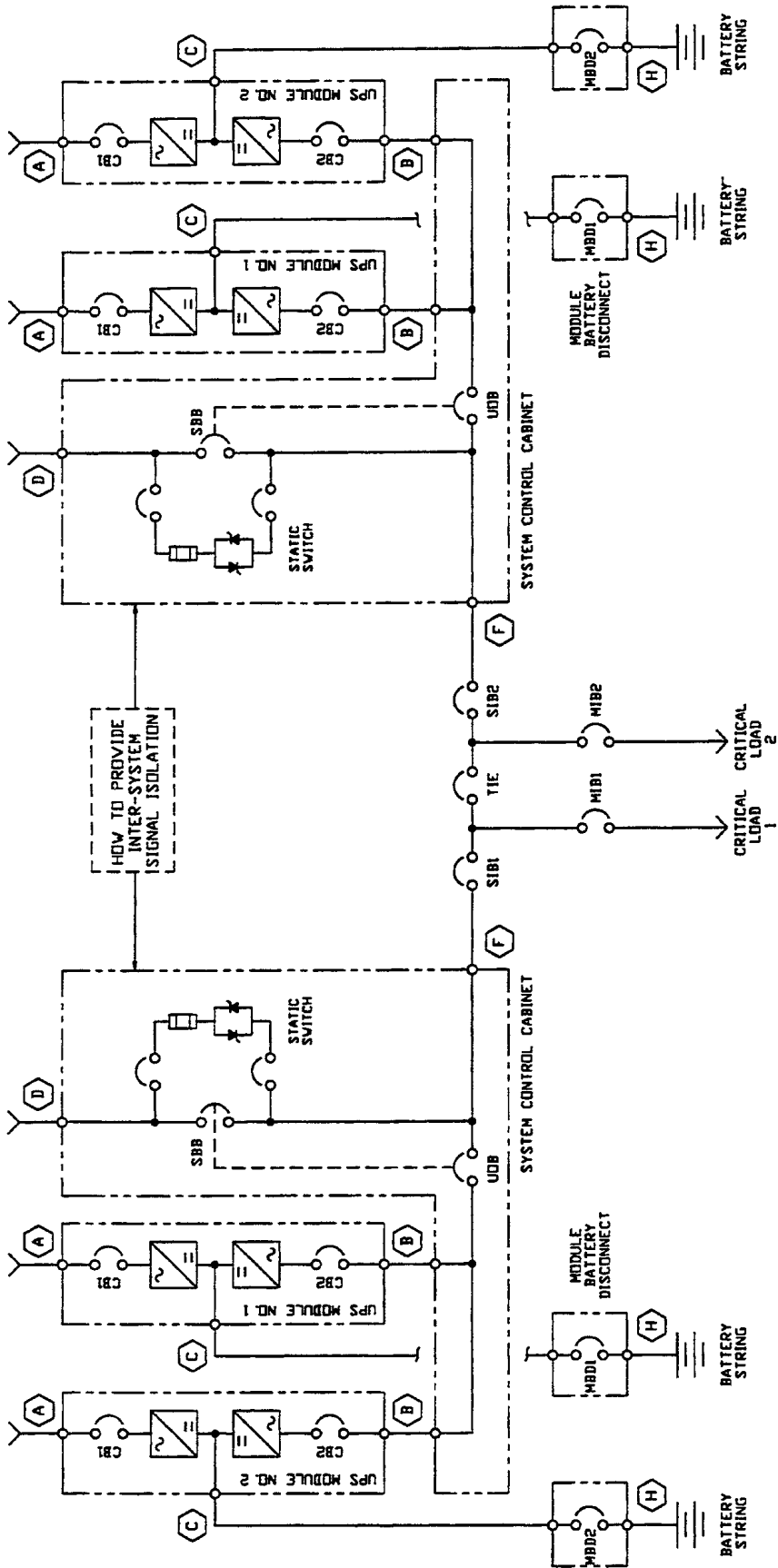
LiBERT <small>NEW JERSEY 800 521-6474</small>	
DRG. NO. RC022242	DATE 02/22/94
ORDER NO.	TITLE
ONE - LINE DIAGRAM POWER TIE SYSTEM	

Figure 3 Power-Tie systems - control interface diagram

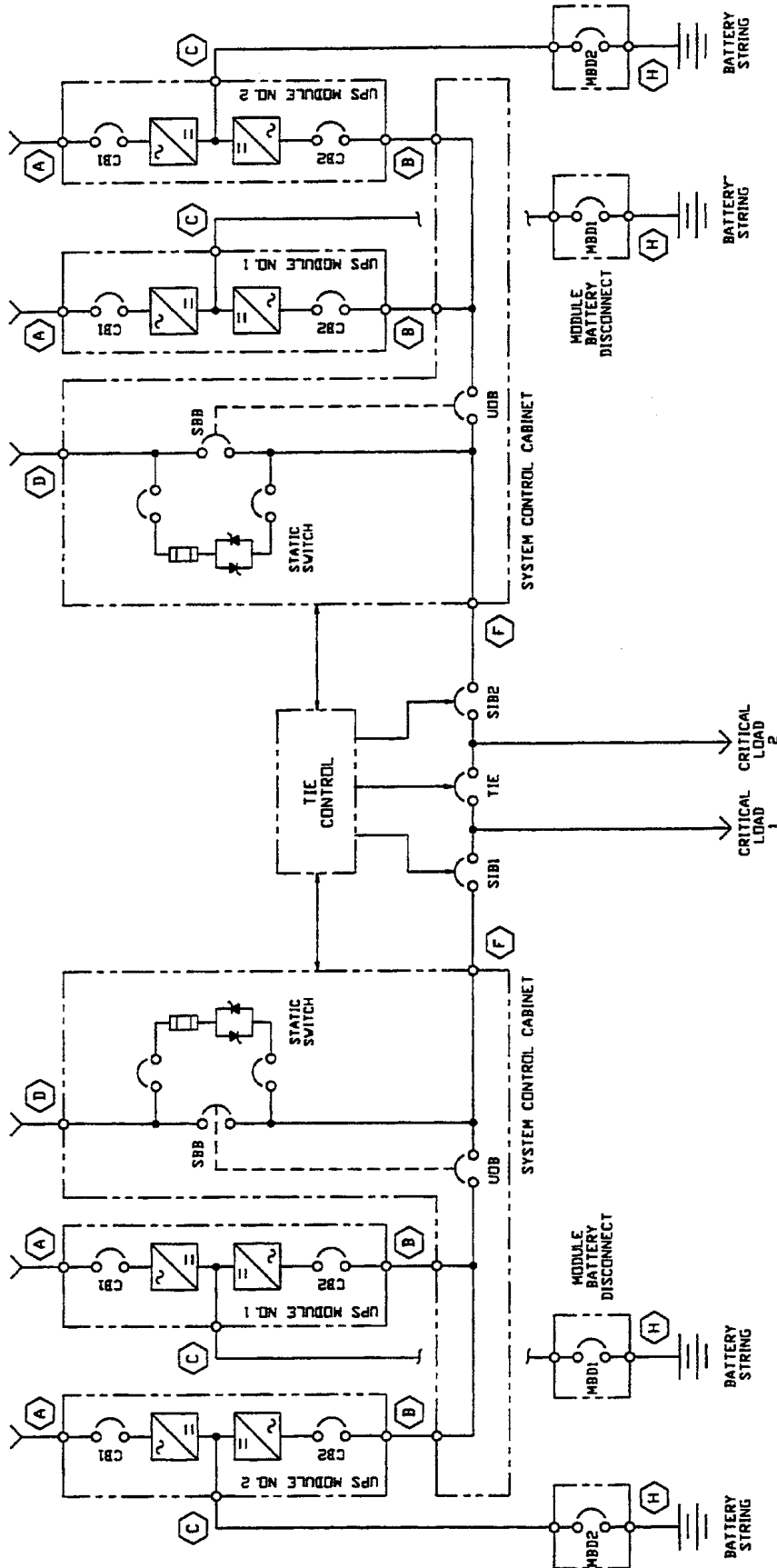

- (A) RECTIFIER AC INPUT
- (B) UPS MODULE AC OUTPUT
- (C) UPS MODULE DC INPUT
- (D) SYSTEM CONTROL CABINET AC INPUT
- (E) UPS SYSTEM AC OUTPUT
- (F) CRITICAL BUS AC OUTPUT
- (G) MODULE BATTERY DISCONNECT TO BATTERY STRING
- (H) MODULE BATTERY DISCONNECT TO BATTERY STRING

DRG. NO. RC022243		DATE 02/22/94		ORDER NO.	TITLE ONE - LINE DIAGRAM POWER TIE SYSTEM



1.4 Control System Features

A key design requirement for maximizing multiple system reliability and inverter availability in tied configurations is assuring maximum system independence under the normal, separated operating conditions.

Liebert has incorporated a number of unique solutions in your Power-Tie System to accomplish these high availability/high reliability performance goals:

Digital Controls

Digital Controls provide more precise control than analog techniques. They permit the direct use of fiber-optics for the most critical inter-system control functions without the need for the additional complexity of A/D and D/A converters. Digital Controls are very reliable—implemented using internally redundant ASICs (application specific integrated circuits) with millions of field-proven trouble-free operating hours—and provide rock-solid UPS load sharing and synchronization control under dynamic load conditions.

Digital Phase Lock of Uninterruptible Power Module (UPM) Inverters

Parallel module inverters are all tightly phase-locked together by redundant digital oscillators. No master oscillator is required. This feature, coupled with closely matched module output impedances, provides the primary module-to-module load sharing function to approximately $\pm 10\%$. This degree of load sharing is good enough, under emergency conditions, to provide acceptable operation for system load sharing and transfer operations.

System Output Voltage Control

A separate, independent and isolated system control function for output voltage which also makes a secondary contribution to the load share function of an additional $\pm 3\%$.

Module Load Sharing

An additional, separate, independent secondary control function contributes another $\pm 3\%$ of inter-module load sharing.

These three independent control functions are additive in contribution to the module load share function, and provide an additional level of redundancy to this function without simply duplicating a circuit.

In combination, these three control functions provide module load sharing to better than $\pm 5\%$. The system will continue to operate acceptably well with the loss of one or more of these control functions. The loss of which will be annunciated through the diagnostic system.

In a tied system configuration these critical functions, coupled with the Tie Control Unit, provide the degree of load share control required, while maintaining system-to-system independence and isolation.

1.5 Operational Description

1.5.1 Operational Choices

See **Figure 3**.

Momentary Tie provides intersystem transfer capability without bypass required, permitting on-line maintenance of the unloaded UPS and distribution system.

Available as a separately packaged hardware option, Continuous Tie permits tying the available modules in both systems together to act as a single multi-module system, in the unlikely event that multiple module failures have reduced the capacity of the UPS system(s). For more information on this performance feature, contact your local Liebert sales representative or call Liebert Global Services (LGS) at 1-800-LIEBERT.

1.5.2 Momentary Tie Operation

See **Figure 3**.

Momentary Tie operation provides manually initiated, uninterrupted transfers of a critical load bus between two otherwise independent multi-module UPS systems. This topology permits individual UPS shutdown for maintenance while its load continues to be supplied by another UPS without the necessity of transferring the load to bypass during shutdown or restart of the UPS being maintained.

A major goal in the design of Momentary Tie Operation was to provide the same high reliability associated with a standard parallel redundant system while providing more system flexibility for maintenance purposes.

The key to maximizing reliability of this configuration is to maintain as much independence as possible between systems, and retain the same basic concepts in transfer philosophy that have served so well in current standard Series 610 UPS systems (as well as previous Series 500 designs).

The only time intersystem controls are active is during the actual operation of transferring loads back and forth between the UPS systems, a period of a few cycles. At all other times, the UPS systems are operating independently.

Following are two main functions associated with the Momentary Tie:

- Intersystem synchronizing
- Intersystem transfer control and switchgear

Intersystem Synchronizing

Synchronization between UPS systems is accomplished by momentarily synchronizing one UPS output (the system accepting the load) to the same sync source the other system is using. The internal clock frequency reference will be used if the Bypass Source is not available as a frequency reference.

When sync signal coincidence is achieved the module sync buses will be tied to lock the modules of both systems in tight synchronization. The associated Tie Control Unit does not perform the sync function, but instead simply supplies each UPS with a sync reference signal, depending on which direction the transfer is going to go. Synchronization of each UPS will automatically revert to its internal bypass sync at the conclusion of the transfer sequence.

Momentary Tie Transfer Controls

The transfer control operates the Tie Breaker and System Isolation Breakers in a sequential make-before-break manner to permit the uninterrupted transfer of a critical load between two UPS systems.

The breakers are operated such that there is an approximate 5 cycle overlap time when the two UPS systems are paralleled prior to one or the other UPS being isolated by its associated Isolation Breaker. Or, the systems are separated via the Tie Breaker opening when returning a load to its normal position).

Should one system transfer to bypass due to overloads or faults, this function can be used to transfer the critical load bus to the second on-line system. The second system is able to pick up the load from the first system's bypass without having to bypass the second system.

This transfer operation is identical to the normal internal transfer from UPS to bypass and return, an operational sequence that is a reliability cornerstone of the Liebert UPS. The difference in this tie function is that the Isolation and Tie breakers replace the functions otherwise performed by the System Bypass Breaker (SBB) and UPS Output Breaker (UOB) devices.

The Tie Control Unit also contains interlock and monitoring circuitry necessary to assure successful transfers of load between UPS systems. These consist of the following:

1. Sync Verification circuitry, similar to the circuitry employed in each UPS, provides the sync check function in two independent modes:
 - a. Phase Difference detection for ± 3 degrees.
Phase Difference inhibits a transfer if limits are exceeded.
 - b. Voltage Difference detection for $\pm 3\%$.
Voltage Differential inhibits transfers if limits are exceeded (if phase error is greater than ± 3 degrees, the Voltage Difference will also exceed $\pm 5\%$), making the differential voltage detection a redundant phase detector.
2. Load Verification circuitry prohibits transfer if the resulting total system load will exceed the capacity of one UPS System (the system which will assume all the critical load once the transfer is complete).

1.5.3 Tie System Components

See **Figure 4**.

A Liebert Power-Tie Uninterruptible Power System consists of the following basic components:

1. Two complete, independent UPSs with individual load buses, each with the capability to source the combined critical load of the two load buses. Each of the two UPSs may be a single-module system (SMS) or a multi-module system (MMS).
2. Two discrete system input sources, each with the capacity to source the combined critical load. The two input sources need only be acceptable with regard to frequency and voltage. The two sources do not require an in-phase relationship, although under this circumstance, a “V Lockout” alarm will be indicated until the “Sync Systems” button is pushed. Then the “V Lockout” should clear.
3. Two discrete bypass sources, each with the capacity to source the combined critical load. The two bypass sources need only be acceptable with regard to voltage and frequency, such as the utility or an emergency generator, and are not required to be in-phase. However, if make-before-break downstream load switching equipment, such as automatic transfer switches, static transfer switches (STS) or dual input power distribution units, is intended to be used, having the two bypass sources in sync is preferable.
4. One system isolation and tie switchboard containing system isolation breakers and tie breaker(s).
5. Tie Control Unit, wall or floor mounted or installed in the tie switchboard.
6. Optional maintenance bypass breakers and test load distribution.

1.5.4 Modes of Operation

See **Figure 4**.

The Power-Tie Uninterruptible Power System is designed to operate in the following modes:

1. **Normal** - Each load bus is fed from its respective UPS and the tie breaker is open. Each inverter is synchronized to its respective bypass source. Each load is supplied by its inverter(s), with its bypass available as an alternate source.
2. **Momentary Tie** - The load bus and the two UPSs are momentarily paralleled through the tie breaker. Both UPSs are on-line, and the bypass source of one UPS will be selected as the primary sync source. When one UPS drops off-line, then operation reverts to the Combined Loads Mode below.
3. **Combined Loads** - Both loads are running on one UPS through the tie breaker. The combined loads are supplied by the selected UPS's inverter(s), with that UPS's bypass available as the alternate and sync source. This mode is typically used for servicing a UPS system, including its bypass and bypass transfer controls, without placing that UPS's load on bypass.
4. **System Isolation** - A selected load bus which has had all load removed (via shutdown, external maintenance bypass or downstream critical load switchover devices—dual input PDU, STS or ATS) may be isolated from one or both UPSs for maintenance.

Figure 4 Power-Tie system one-line diagram

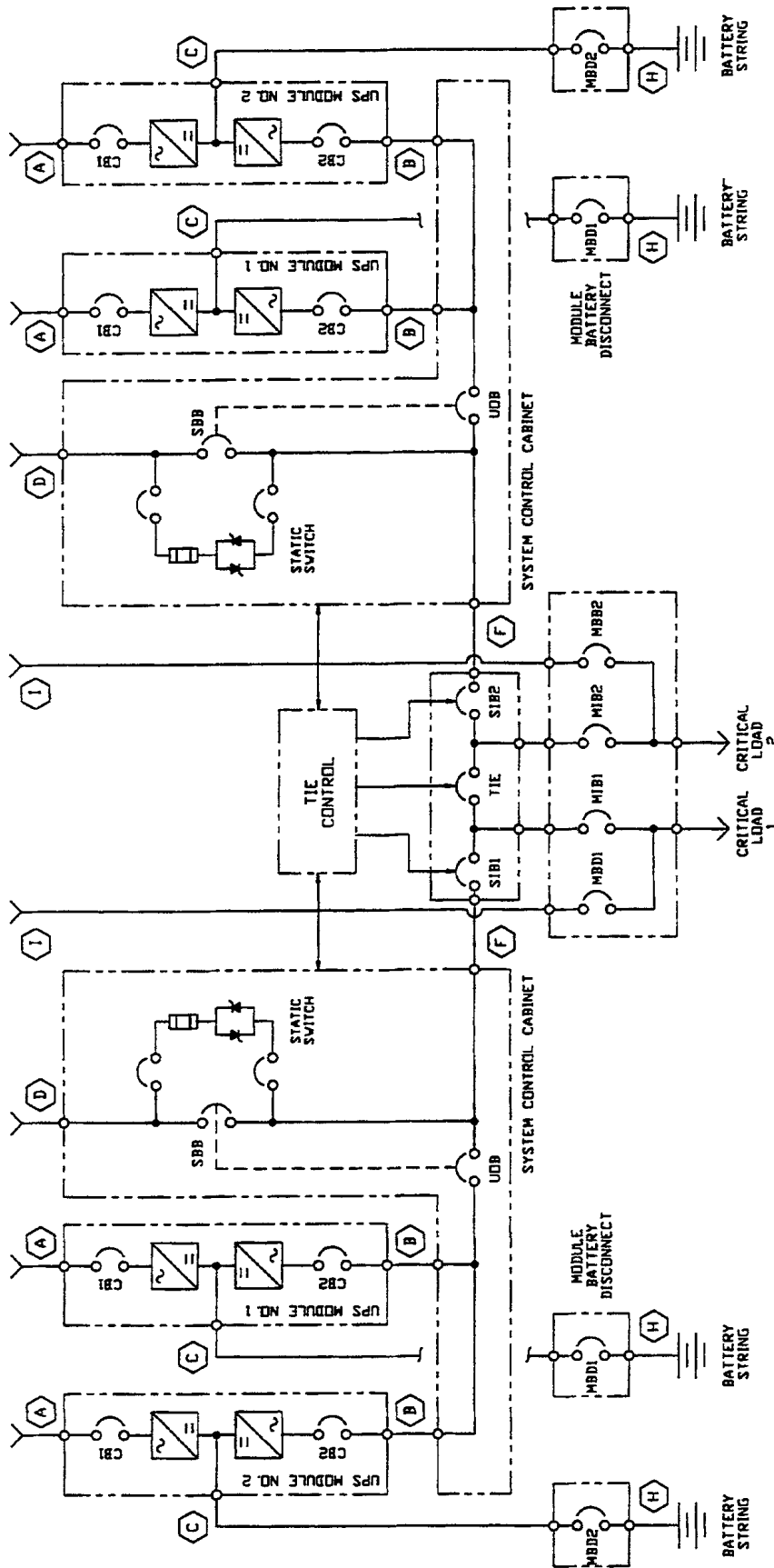

- (A) RECTIFIER AC INPUT
- (B) UPS MODULE AC OUTPUT
- (C) UPS MODULE DC INPUT
- (D) SYSTEM CONTROL CABINET AC INPUT
- (E) UPS SYSTEM AC OUTPUT
- (F) CRITICAL BUS AC OUTPUT
- (G) MODULE BATTERY DISCONNECT TO BATTERY STRING
- (H) MAINTENANCE BYPASS AC INPUT
- (I) TIE CONTROL

		TITLE ONE - LINE DIAGRAM POWER TIE SYSTEM	
DRG. NO. RC02244	DATE 02/22/94	ORDER NO.	ORDER NO.

2.0 OPERATION DESCRIPTION

There are two types of operations which can be performed with the Liebert Momentary Power-Tie System.

- Create a momentary tie between the critical buses of two UPS systems
- Transfer of a critical load between two UPS systems

2.1 Load Transfers Between UPS Systems

Functionally, load transfers are a momentary tie operation followed by an immediate selective separation of the systems. The following sequence of operations describes the actions taken to transfer a load between UPS systems.

Selecting a System for Transfer

Select the system you want to receive the load, system 1 or system 2. Press the TRANSFER LOAD TO button (for system 1 or system 2) on the LOAD TRANSFER CONTROL section of the control panel. The system 1 or system 2 light turns on to indicate your selection.

You can cancel your selection by pressing the system button again. The button toggles between select and deselect.

Synchronizing to the Bypass Source

The two UPS systems synchronize to the proper bypass source to perform the selected transfer. With the line sync controls tied, the Momentary Power-Tie logic checks the inter-module sync signals for coincidence. The Power-Tie logic ties the inter-module sync signals when coincidence occurs.

The SYNCHRONIZING light in the CONTROL STATUS section of the MIMIC panel turns on to let the operator know synchronization is still in progress.

Checking for Phase, Voltage, and Capacity

The Power-Tie logic checks these UPS system parameters, phase, voltage, and capacity, to determine when they have reached their proper limits. The OK TO TRANSFER LOAD (#) TO SYSTEM (#) indicator turns on in the LOAD TRANSFER CONTROL section of the control panel on when these parameters reach their proper limits.

Transferring the Load

After the OK TO TRANSFER LOAD (#) TO SYSTEM (#) light turns on, press the PUSH TO TRANSFER AFTER OK button.

The Power-Tie logic operates the proper circuit breakers in a make-before-break manner to transfer the load.

Once the transfer starts, the TRANSFERRING light in the CONTROL STATUS section of the MIMIC panel turns on indicating a transfer in progress. With the two UPS systems in parallel, the voltage synchronization and power sharing loops become tied.

Transfer Complete

When transfer is complete, both systems automatically resynchronize to their own bypass source; and all control loops between the systems separate.

Figure 5 Control panel layout

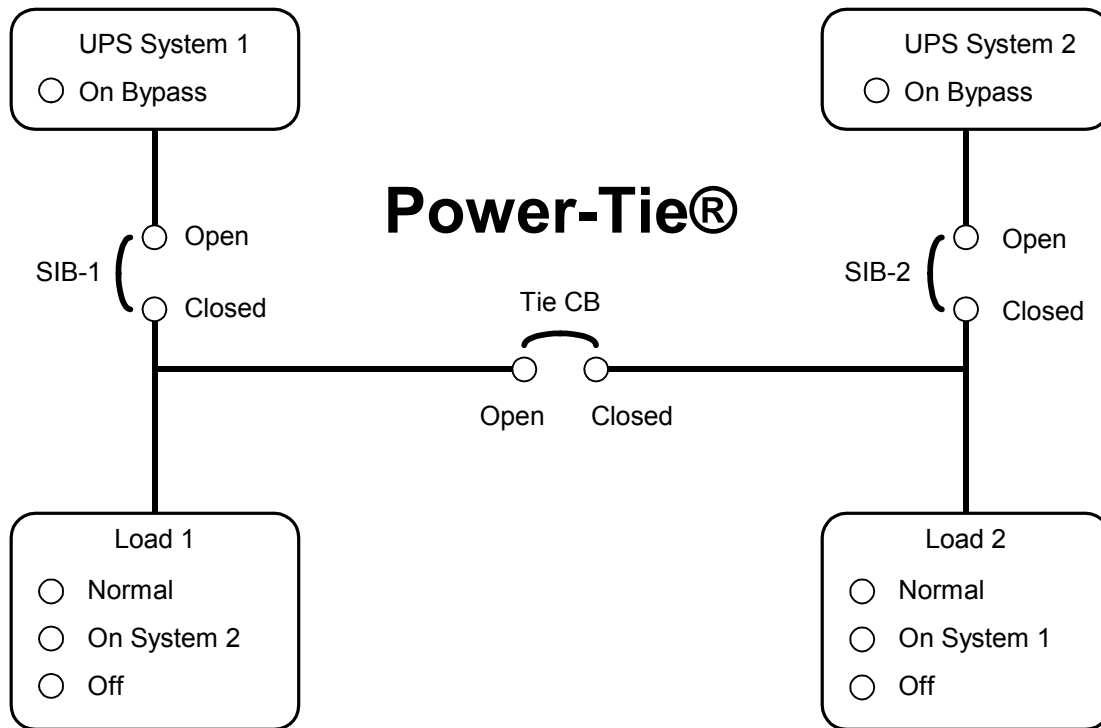

Load Transfer Control

- 'OK' to Transfer Load 1 to System 1
- 'OK' to Transfer Load 1 to System 2
- 'OK' to Transfer Load 2 to System 1
- 'OK' to Transfer Load 2 to System 2
- Synchronizing
- Transferring

Transfer Inhibits

- Phase Lockout
- Voltage Lockout
- Load Lockout
- Logic Failure
- Invalid Operation

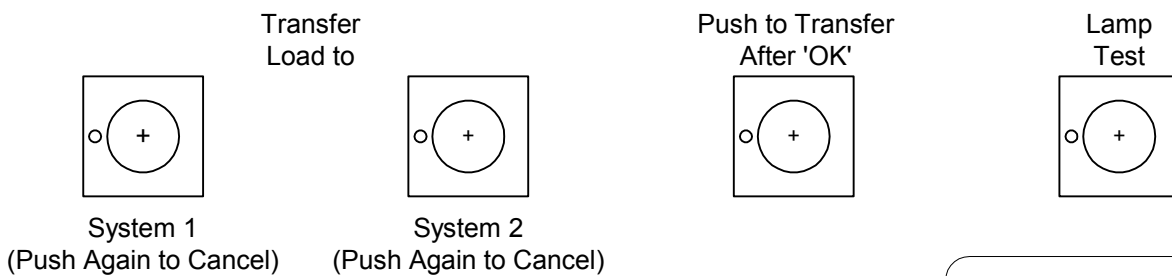

Emergency trip buttons for Tie circuit breakers located on panel behind this door.

NOTES

1. Overall Dimensions: 17.5" x 19.5" (444.5 x 495.3mm).
2. Reference control panel cutout drawing 88-791618-02 for mechanical details.

DWG NO.
88-797620-09
REF. DWG. NO
02-795113-00

2.2 Design Criteria

The ultimate power goal in the design of the Liebert Momentary Tie System is to provide maximum UPS availability and maintainability without compromising the inherent reliability of the UPS systems. We have designed the Momentary Power-Tie system to minimize or eliminate possible failure modes and their effect on the system.

Isolation and Fault Tolerance

See **Figures 6** and **7**.

Signal isolation prevents an internal failure from propagating between systems. By using fiber-optics, optical isolators, and isolation amplifiers, we isolate all control signals between each UPS system and the Power-Tie Controls.

To parallel systems requires some amount of intersystem information. The controls have been designed to be as fault tolerant as possible.

We use a parallel module sync bus means because the system will still function if a 60Hz clock in an individual module fails. The parallel module sync bus eliminates the need for a system master oscillator function.

In tied systems we use a parallel module sync and fiber-optics. Fiber optics transport the digital module sync signals between systems to maintain isolation. We use fiber optics for these signals since they are the most critical intersystem signals in parallel systems.

Load Share Signal

The Load Share signal is sent between UPS systems when they are in parallel. Isolation amplifiers isolate the Load Share signal levels between the systems. The load sharing loop and the voltage control improves the module load sharing capability of the modules to within $\pm 5\%$ of module load.

Because a Momentary Tie system uses modules of the same kVA/kW rating, the modules have some inherent capability to share loads due to their similar output impedance. Load Share signals are not as critical as module sync signals.

System Voltage Control Signal

The System Voltage Control signal is sent between UPS systems when they are in parallel. Isolation amplifiers isolate the System Voltage Control signal levels between the two systems. The System Voltage Control signal helps to maintain load sharing by giving all the modules a common reference signal for output voltage. The System Voltage Control signal is not a critical signal. Loss of the System Voltage Control signal should only cause a minor degrade in module sharing capability, if at all.

Line Sync Signal

The Line Sync signal is sent between UPS systems when they are in parallel. Isolation amplifiers isolate the Line Sync signal levels between the two systems. The Line Sync signal synchronizes the UPS systems to the Primary Bypass line. By maintaining sync with the Primary Bypass, uninterrupted transfers to the Primary Bypass can be made, if a fault occurs while the systems are in parallel.

All status signals sent between the UPS system and the Tie Controls are isolated through optical couplers. In addition, all these status signals have impedance protection between the signal wire connections and the system power supplies and ground.

The Tie Control's power supply can use either UPS system's output as its source and the Tie Control power supply employs transformer isolation.

All necessary voltage sensing occurs at the tie cabinet and employs fuse, transformer and/or impedance protection.

Figure 6 Power-Tie system - fault isolation issues

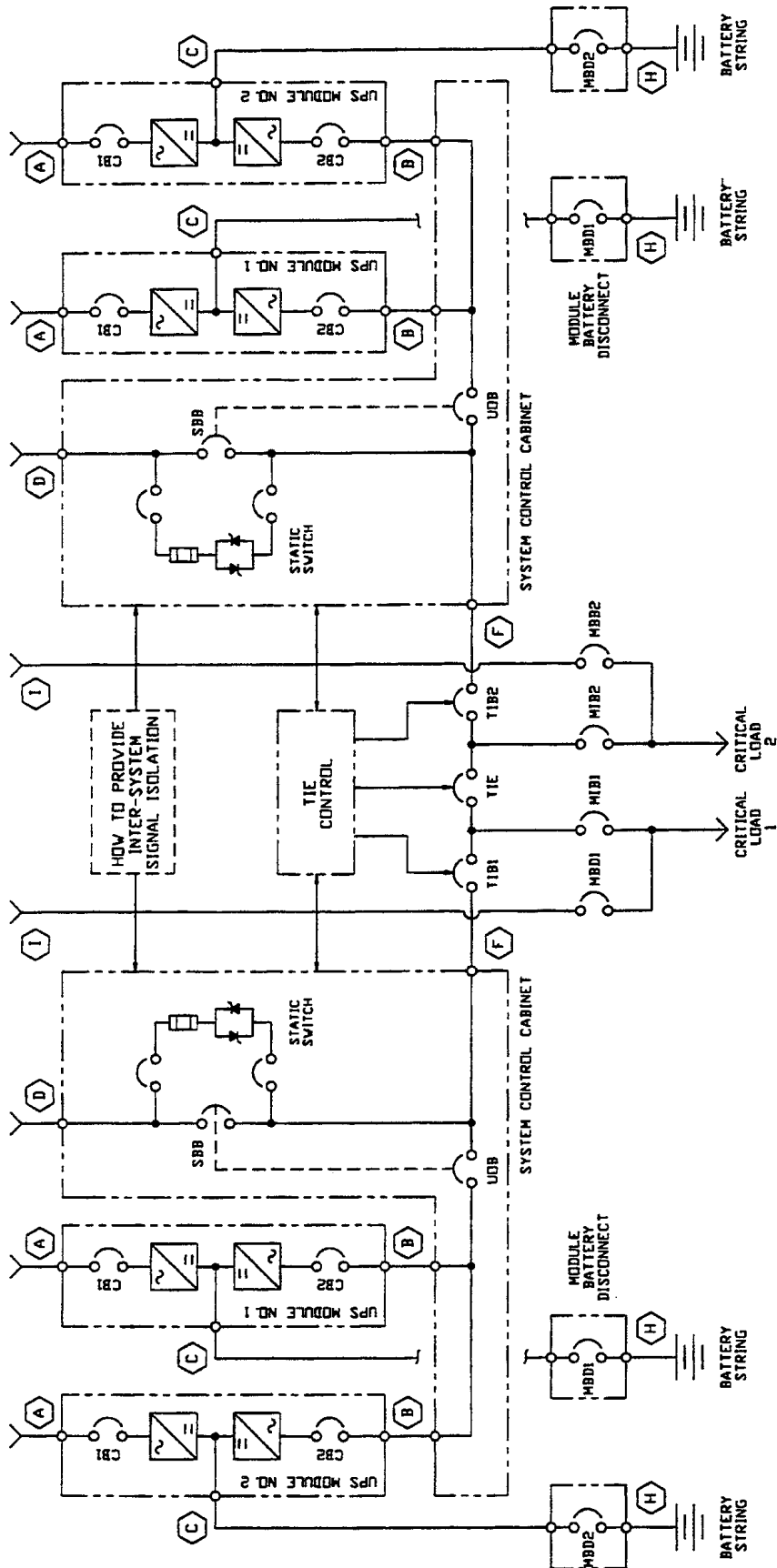

- (A) RECTIFIER AC INPUT
- (B) UPS MODULE AC OUTPUT
- (C) UPS MODULE DC INPUT
- (D) SYSTEM CONTROL CABINET AC INPUT
- (E) UPS SYSTEM AC OUTPUT
- (F) CRITICAL BUS AC OUTPUT
- (G) MODULE BATTERY DISCONNECT TO BATTERY STRING
- (H) MAINTENANCE BYPASS AC INPUT
- (I) CRITICAL LOAD

DRG. NO. RC02247		DATE 02/22/94		ORDER NO.		TITLE ONE - LINE DIAGRAM POWER TIE SYSTEM	
---------------------	--	------------------	--	-----------	--	---	--



Figure 7 Power-Tie systems - fault tolerance

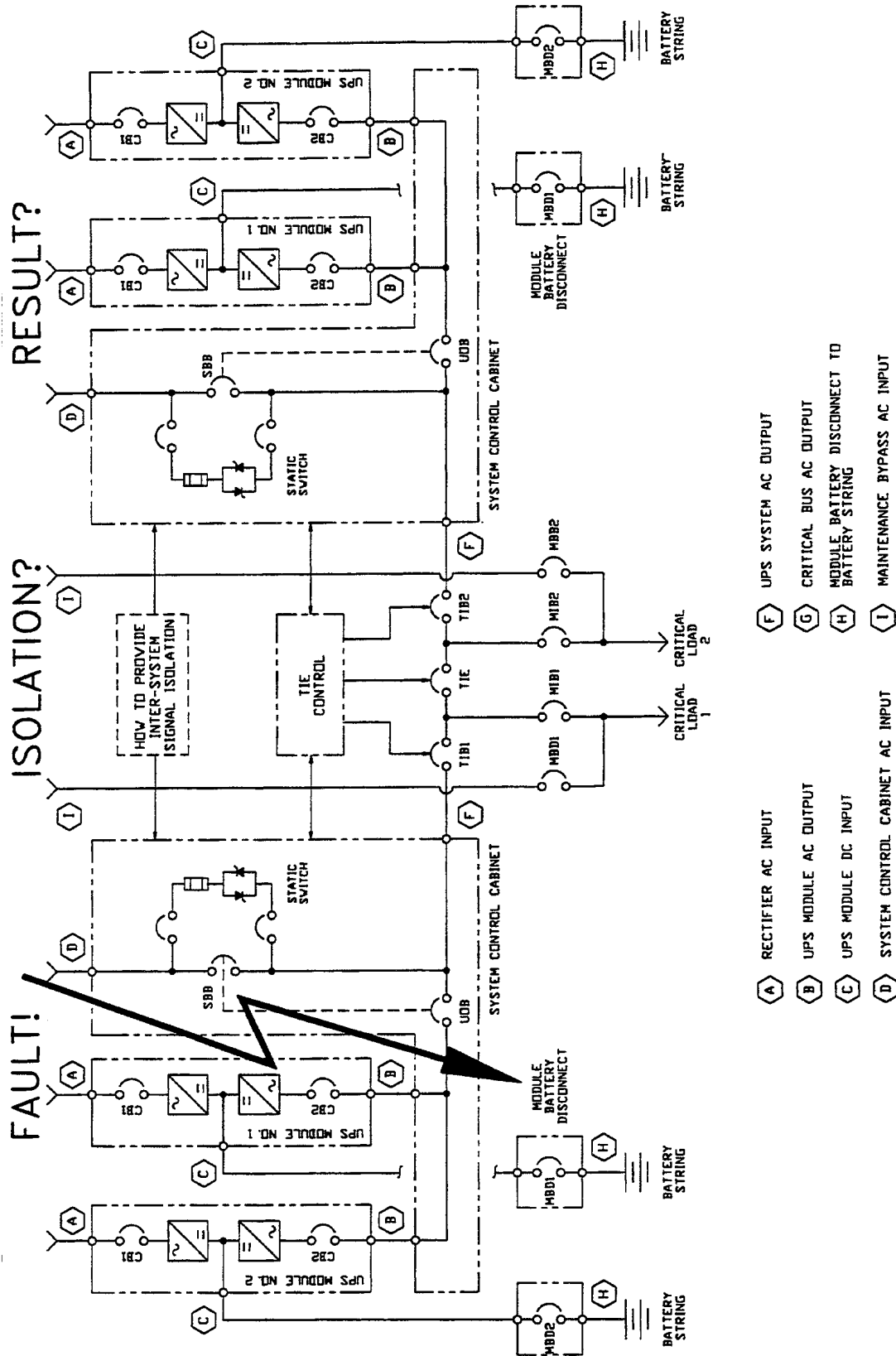

DRG. NO. RC022249		DATE 02/22/94	ORDER NO.	TITLE ONE - LINE DIAGRAM POWER TIE SYSTEM
----------------------	--	------------------	-----------	---



2.3 Improper User Operation

See **Figures 4 and 5**. The Power-Tie Operator controls and logic are designed so that improper operator use does not directly cause a loss of critical bus functions. Additional security functions, such as removable key switches, are available as system options.

Transfer Operation

Transfer functions require two push-button operations. Pushing any single button at random, does not put the system at risk. The Power-Tie system has redundant status sensors and monitors them for proper operation.

The operator should use good judgement when operating the Tie Control. The Tie Control cannot prevent an operator from tying to a source that subsequently goes bad.

For example, assume one UPS has gone to bypass. You want to bring the bypass feeder onto the second system. The second system must momentarily tie to the first system's bypass source. If a bypass fault occurs in the first system during the tie operation, both load feeders could fault. To prevent this type of fault, put the first system's bypass source on a standby engine generator.

Tie Operation

The tie process only requires selection of the desired Primary Bypass Source (which may be left in a default desired position) and the sequential pushing of two buttons. The Power-Tie logic takes care of synchronizing to the select Primary Bypass Source, checking that the systems are in an acceptable configuration, verifying that electrical parameters are within tolerance, and verifying sufficient combined systems capacity.

The sequential operation serves both to eliminate accidental operation and allows the operator an opportunity to cancel an undesired action. Before a transfer or tie operation can be performed the Power-Tie control turns on an OK indicator.

The OK indicator clearly describes the action which will occur.

If the action indicated is not the desired action, the operator simply presses the button he used to initiate the original operation and the operation is canceled. Directions on how to use the "Push Again to Cancel" feature are posted on the Power-Tie control panel, next to each applicable push button.

2.4 Tie Circuit Breaker or Logic Faults

The Momentary Power-Tie system has been designed to anticipate circuit breaker and logic faults. Should a circuit breaker or logic fault occur, the Power-Tie system maintains the critical bus function under fault conditions

2.4.1 What Happens If a Failure Occurs During a Power Transfer

During normal operation, the Power-Tie logic maintains system isolation. Upon power transfer initiation, the Power-Tie logic checks the circuit breaker (CB) positions. The Power-Tie logic inhibits the power transfer if the circuit breaker positions are incorrect.

For Momentary Tie, if all circuit breakers are in their correct positions, then all circuit breakers momentarily remain closed, tying both systems together. The power transfer sequence stops. The static bypass becomes the backup.

If the operator selects momentary Power-Tie, the isolation circuit breaker opens. If this circuit breaker fails to open, the system returns to its initial configuration, maintaining the critical bus.

2.4.2 What Happens If a Logic Failure Occurs During Power Transfer

If a failure occurs before the power transfer, the Power-Tie logic inhibits the power transfer operation.

If a failure during the power transfer, one of the following occurs:

- If the failure occurs before overlap period has timed out, the Power-Tie logic returns the system to its initial configuration.
- If failure occurs after overlap period has expired (e.g., the isolating breaker has already been commanded to trip), the Power-Tie logic completes the transfer.
- If the power transfer does not complete (e.g., the isolating breaker fails to trip within an acceptable time period), the Power-Tie logic returns the system to its initial configuration.
- If the failure occurs after the transfer has occurred, the static bypass becomes the backup.

2.4.3 Hardware Failures

Improper operation of the Power-Tie are caused primarily by tie circuit breaker failures. The Power-Tie logic monitors the “Close” and “Open” sent to the circuit breakers. If the breaker command is not completed by the breaker within an acceptable time period, the Power-Tie logic takes corrective action. The Power-Tie implements corrective action based on the operation being performed and the current system configuration.

The Power-Tie logic takes protective action if a fault occurs on a UPS system during a load transfer or while the UPS systems momentarily are in parallel operation. The Power-Tie logic takes action based on the current system configuration and the active operation to minimize the affects of the fault.

The Power-Tie controls add additional protection to the individual UPS systems. And, the protective controls of the individual UPS become an integral part of the overall fault protection scheme used by the Power-Tie controls.

2.5 Recommendations - Tie Circuit Breaker Selection

Consider using non-automatic circuit breakers for momentary Power-Tie applications. The circuit breaker function should not be the primary fault limiting function. Using non-automatic circuit breakers eliminates a primary circuit breaker failure mode, the trip unit components within the circuit breaker.

3.0 CONTROL PANEL DESCRIPTION

Refer to **Figure 5**.

3.1 Mimic Panel

The Mimic panel consists of the following:

- UPS SYSTEM 1 - PRIMARY BYPASS
- UPS SYSTEM 2 - PRIMARY BYPASS
- UPS SYSTEM 1 - ON BYPASS
- UPS SYSTEM 2 - ON BYPASS
- LOAD 1 CIRCUIT BREAKER
- LOAD 2 CIRCUIT BREAKER
- TIE CIRCUIT BREAKER

- LOAD 1 - NORMAL
- LOAD 1 - ON SYSTEM 2
- LOAD 1 - SYSTEMS TIED
- LOAD 1 - OFF

- LOAD 2 - NORMAL
- LOAD 2 - ON SYSTEM 1
- LOAD 2 - SYSTEMS TIED
- LOAD 2 - OFF

- CONTROL STATUS - SYNCHRONIZING
- CONTROL STATUS - TRANSFERRING

UPS System 1 - Primary Bypass

This light turns on when UPS System 1 is the selected Primary Bypass. When lit, the light indicates the UPS Modules of both UPS systems are synchronizing to the bypass of UPS System 1, when systems are tied or in the process of transferring load.

UPS System 2 - Primary Bypass

This light turns on when UPS System 2 is the selected Primary Bypass. When lit, the light indicates that the UPS Modules of both UPS systems are synchronizing to the bypass of UPS System 2, when systems are tied or in the process of transferring load.

UPS System 1 - On Bypass

This light turns on when UPS System 1 is on Bypass.

UPS System 2 - On Bypass

This light turns on when UPS System 2 is on bypass.

Load 1 Circuit Breaker

These two lights indicate the OPEN (Red light) or CLOSED (Green light) state of the Load 1 circuit breaker.

Load 2 Circuit Breaker

These two lights indicate the OPEN (Red light) or CLOSED (Green light) state of the Load 2 circuit breaker.

Tie Circuit Breaker

These two lights indicate the OPEN (Red light) or CLOSED (Green light) state of the Tie circuit breaker.

Load 1 - Normal

This light indicates that Load 1 is being supplied by UPS System 1. Load 1 supplied by UPS system 1 represents the normal operating mode.

Load 1 - On System 2

This light indicates that Load 1 is being supplied by UPS System 2 through the Tie circuit breaker.

Load 1 - Systems Tied

This light indicates that Load 1 is being supplied by both UPS Systems which share the combined loads.

Load 1 - Off

This light indicates that Load 1 is isolated from both UPS Systems.

Load 2 - Normal

This light indicates that Load 2 is being supplied by UPS System 2. Load 2 supplied by UPS system 2 represents the normal operating mode

Load 2 - On System 1

This light indicates that Load 2 is being supplied by UPS System 1 through the Tie circuit breaker.

Load 2 - Systems Tied

This light indicates that Load 2 is being supplied by both UPS Systems which share the combined loads.

Load 2 - Off

This light indicates that Load 2 is isolated from both UPS Systems.

Control Status - Synchronizing

This light indicates that the UPS Systems are currently synchronizing to the selected bypass line.

Control Status - Transferring

This light indicates that the controls are transferring a load from one system to the other system.

3.2 Load Transfer Controls

This section of the control panel gives indications and allows control of load transfers between the UPS Systems.

OK to Transfer Load 1 to System 1

This light indicates that it is safe to transfer Load 1 from UPS System 2 to UPS System 1. The transfer occurs when the PUSH TO TRANSFER AFTER OK button is pressed, but only if this light is on.

OK to Transfer Load 1 to System 2

This light indicates that it is safe to transfer Load 1 from UPS System 1 to UPS System 2. The transfer occurs when the PUSH TO TRANSFER AFTER OK button is pressed, but only if this light is on.

OK to Transfer Load 2 to System 1

This light indicates that it is safe to transfer Load 2 from UPS System 2 to UPS System 1. The transfer occurs when the PUSH TO TRANSFER AFTER OK button is pressed, but only if this light is on.

OK to Transfer Load 2 to System 2

This light indicates that it is safe to transfer Load 2 from UPS System 1 to UPS System 2. The transfer occurs when the PUSH TO TRANSFER AFTER OK button is pressed, but only if this light is on.

Transfer Control Disabled

This light indicates that load transfers are not allowed because the systems are currently being put in parallel operation.

Transfer Function Available

The Transfer Function Available lights indicate the transfer options the operator has available based on the current system configuration.

Transfer Function Available - OK to Transfer Load 1 to System 1

This light indicates that the systems are in a configuration where a transfer of load 1 from UPS System 2 to UPS System 1 can be attempted.

Transfer Function Available - OK to Transfer Load 1 to System 2

This light indicates that the systems are in a configuration where a transfer of load 1 from the UPS System 1 to UPS System 2 can be attempted.

Transfer Function Available - OK to Transfer Load 2 to System 1

This light indicates that the systems are in a configuration where a transfer of load 2 from UPS System 2 to UPS System 1 can be attempted.

Transfer Function Available - OK to Transfer Load 2 to System 1

This light indicates that the systems are in a configuration where a transfer of load 2 from UPS System 1 to UPS System 2 can be attempted.

Transfer Load To - System 1

When this button is pressed, it initiates a sequence to allow a load transfer to UPS System 1. The transfer to be performed is automatically determined by the current state of the Tie and Load circuit breakers. The button turns on indicating that the sequence is armed. When the control logic determines all conditions for a safe transfer have been met, it turns on the appropriate OK TO TRANSFER light.

Transfer Load To - System 2

When this button is pressed it initiates a sequence to allow a load transfer to UPS System 2. The transfer to be performed is automatically determined by the current state of the Tie and Load circuit breakers. The button turns on indicating that the sequence is armed. When the control logic determines that all conditions for a safe transfer have been met, it turns on the appropriate OK TO TRANSFER light.

Push to Transfer After OK

This button starts the transfer after the OK TO TRANSFER light turns on.

3.3 Control Inhibits

This section of the control panel provides alarm indicators which prevent transfers and parallel operation of the UPS systems.

Phase Lockout

This light indicates the systems are not synchronized. It is a waveform-based redundant check of synchronization. The primary sync indicator is based on UPS module sync bus coincidence.

This light normally turns on while the systems are synchronizing prior to a Tie or Transfer operation. If the light does not turn off, contact Liebert Global Services for assistance.

Voltage Lockout

This light indicates the system voltages are too far apart to allow safe transfers and parallel operation of the UPS systems. To correct this condition, adjust the UPS system voltage to proper levels.

If both system voltages are adjusted correctly, and the PHASE LOCKOUT alarm is not present, then check the voltage detection circuitry. Contact Liebert Global Services for assistance.

Load Lockout

This light indicates insufficient UPS capacity to perform the selected operation. The control logic intelligently checks the UPS systems and the Loads based on the specific operation in progress.

Verify UPS capacity and shed load as necessary until UPS capacity is not being exceeded. If UPS capacity is sufficient, then check the load/capacity detection circuitry. Contact Liebert Global Services for assistance.

Logic Failure

This light indicates that a logic failure has occurred. No Tie operations are allowed while this condition exists.

Check all tie control logic functions to determine the source of the fault. Contact Liebert Global Services for assistance.

Lamp Test

This button is pressed to check all indicators on the MIMIC and CONTROL PANEL.

3.4 Manual Controls

These controls are located on a panel behind the Control Panel door. They are provided to assist in initial system start-up and provide emergency manual breaker trip capability. During normal operations they should not need to be used.

Close Load 1

This button closes the Load 1 circuit breaker during start-up. It only functions if the Tie breaker is open.

Close Load 2

This button closes the Load 2 circuit breaker during start-up. It only functions if the Tie breaker is open.

Trip Load 1

This button is used to manually trip the Load 1 circuit breaker and is provided for emergency purposes.

The light on this push button will go out when load is being supplied through the breaker. Pressing this button when the light is out will result in loss of power to an on-line load.

Trip Load 2

This button is used to manually trip the Load 2 circuit breaker and is provided for emergency purposes.

The light on this push button will go out when load is being supplied through the breaker. Pressing this button when the light is out will result in loss of power to an on-line load.

Trip Tie

This button is used to manually trip the Tie circuit breaker and is provided for emergency purposes.

4.0 OPERATING INSTRUCTIONS

Refer to **Figure 5**.

4.1 Initial System Start-Up

All load circuit breakers and tie circuit breakers are initially open.

1. Press the CLOSE LOAD 1 button located on the panel behind the Control door. The Load 1 breaker should close when the button is pressed.
2. Press the CLOSE LOAD 2 button located behind the Control door. The Load 2 breaker should close when the button is pushed.



NOTE

The operation can be performed with the UPS on bypass or inverter output. The Power-Tie logic confirms that the Tie breaker is open to prevent inadvertently putting the systems in parallel.

3. Once one or both UPS systems are on-line, a transfer of either critical load between systems or a momentary tie operation can be performed subject to conditions outlined in **1.0 - System Description** and **2.0 - Operation Description** and the following sections.

4.2 Basic Operation

4.2.1 Momentary Tie - Load Transfers

A momentary tie operation is used to transfer a critical load from a UPS system, which requires isolation for maintenance, to another UPS system without placing the critical load on utility bypass.

The isolated UPS system can be serviced while the critical load remains protected by a fully functional UPS system. Once service is complete, perform another Momentary tie operation to return the critical load to its normal UPS system. This can be done without placing the critical load on utility bypass.

4.2.2 Normal Transfer Operation Configurations

Transfers of a critical load between systems can be performed from several initial system configurations. The guiding criteria for permitting transfers is that the critical load must remain on UPS inverter output.

Transfers to a UPS system operating on its bypass source cannot be initiated due to logic lockouts. However, a critical load initially on a UPS system's bypass source can be transferred to the other UPS system operating on inverter output.

In addition to checking system configurations, the Power-Tie logic uses three independent criteria for verifying synchronization. The Power-Tie logic verifies system voltages are within proper limits. And the Power-Tie logic verifies the UPS system which will accept the additional load has sufficient UPS capacity.

The logic intelligently determines which system to synchronize with, which UPS system capacity to check, and which load(s) to check, based on which system the operator selects to transfer load. The Power-Tie logic "knows" the present system configuration.

The Power-Tie logic automatically returns both UPS systems to independent operation by resynchronizing them to their own bypass source and separating all control loops between the systems when the transfer is complete.

4.2.3 Maintenance Procedures - Isolating Each UPS System

Power-Tie system capabilities permit each UPS system to be completely isolated for service while its load continues to be powered and protected by the other UPS system. In addition, since all controls of each system are electrically isolated from the other system, any operation or fault on the system being serviced does not affect the system supplying the combined loads.

4.2.4 Isolating a UPS System for Maintenance - Combined Loads Operation

Both Load circuit breakers are initially closed and the Tie circuit breaker initially open. The Tie circuit breaker is closed if the UPS systems are currently in parallel operation.

1. Select the UPS system that will carry both loads by pressing the appropriate SYSTEM button in the LOAD TRANSFER CONTROL section of the control panel. If System 2 is to be isolated then the press the SYSTEM 1 button. Load 2 will be transferred to System 1.
2. Wait for the OK TO TRANSFER LOAD light to turn on. If System 2 is to be isolated then the OK TO TRANSFER LOAD 2 TO SYSTEM 1 light should turn on when it is safe to perform the transfer.
3. Once the OK indication is received, press the PUSH TO TRANSFER AFTER OK button and the transfer will be performed. If System 2 is to be isolated then the Tie breaker will close. Then, the Load 2 circuit breaker opens after the overlap period times out.
4. The isolated UPS system (System 2) can now be safely serviced.

4.2.5 Transfer of Load Between Two Systems

This procedure may be performed from three initial states:

- Tie circuit breaker is open and both load circuit breakers are closed.
 - Both loads are on System 1.
 - Both loads are on System 2. The UPS system losing the load may be on UPS or Bypass. The UPS system accepting the load must be on UPS.
1. Select the UPS system to carry the transfer load. Press the TRANSFER LOAD TO SYSTEM (#) button. If you want to transfer Load 2 to System 1, press the "SYSTEM 1" button. Both systems synchronize to the bypass of the system receiving the additional load. The SYNCHRONIZING light in the CONTROL STATUS section of the mimic turns on while the systems are synchronizing. The light turns off when the sync lines (bypass and oscillator) are in the proper state.

At this point the OK TO TRANSFER LOAD (#) TO SYSTEM (#) light should turn on if there are no inhibits. If Load 2 can be transferred to System 1, the OK TO TRANSFER LOAD 2 TO SYSTEM 1 light turns on.



NOTE

When a transfer sequence is initiated, the Tie controls are locked out and the TIE CONTROL DISABLED light turns on.

2. After the OK TO TRANSFER LOAD (#) TO SYSTEM (#) light turns on, press the PUSH TO TRANSFER AFTER OK button to transfer the load. The proper circuit breaker closes and, after a delay, the proper isolating circuit breaker opens. While the systems are tied the Load Sharing and Voltage Adjust Controls will also be tied between the systems. The LOAD TRANSFERRING light turns on to tell the operator that a transfer is in progress. Once transfer is complete, the systems return to their own internal sync, the current share and voltage adjust controls separate, the TRANSFERRING and TIE CONTROL DISABLED lights turn off. The SYSTEM (#) push-button light turns off and the NORMAL status light turns on. All load transfers follow this same procedure. The logic knows whether Load 2 is to be transferred from System 2 to System 1 or Load 1 is being returned to System 1. The SYSTEM 1 button is pressed for both operations because the systems' initial configuration make only one choice possible.

4.2.6 Returning an Isolated System to Normal Operation - End Combined Loads Operation

One Load circuit breaker and the Tie circuit breaker are closed. The Load circuit breaker of the isolated system which was being serviced will be opened.

1. Select the UPS system to accept the load. Press the TRANSFER LOAD TO SYSTEM (#). If System 2 had been isolated then press the SYSTEM 2 button. Load 2 will be returned to System 2.
2. Wait for the OK TO TRANSFER LOAD light to turn on. If System 2 was isolated then the OK TO TRANSFER LOAD 2 TO SYSTEM 2 light should turn on when it is safe to perform the transfer.
3. After the OK TO TRANSFER LOAD 2 TO SYSTEM 2 light turns on, press the PUSH TO TRANSFER AFTER OK button. The transfer will be performed. If System 2 was isolated then the Load 2 breaker will close and the Tie circuit breaker opens after the overlap period times out.
4. Both UPS systems will now be supplying their normal Load and operating independent of each other.

4.2.7 Maintenance Procedures - Maintaining Power-Tie Components

Refer to the procedures in **4.2.3 - Maintenance Procedures - Isolating Each UPS System** to isolate the UPS's load circuit breaker and the associated downstream feeders for service.

By using downstream switchover devices for the individual critical loads, such as ATs or dual input PDUs, the load feeder components to be maintained are de-energized. All critical load operations are transferred to the feeder which will power the combined loads.

There are three approaches to maintaining the Tie circuit breaker and its associated circuit components depending on the convenience and isolation desired.

1. **Single fixed-mount Tie circuit breaker**
Complete UPS system and critical loads must be placed on a reliable maintenance bypass source (e.g., standby engine-generator) to de-energize the Tie circuit breaker.
Using appropriate safety equipment and procedures, the Tie circuit breaker can be serviced while one or both systems remain energized (depending on isolation breaker usage).
2. **Single drawout Tie circuit breaker**
Drawout mechanism permits servicing the Tie circuit breaker and associated circuitry while the Power-Tie system is in its normal mode of operation.
To de-energize the drawout carriage plug-in stubs and buswork, however, one feeder at a time must be isolated for service. Refer to **4.2.3 - Maintenance Procedures - Isolating Each UPS System**.
Using appropriate safety equipment and procedures, these components can be serviced while one or both systems remain energized (depending on isolation breaker usage).
3. **Two Tie circuit breakers in series—Fixed-mount or Drawout**
By using two Tie circuit breakers in series, each circuit breaker and its associated buswork can be conveniently and completely de-energized for service. Refer to **4.2.3 - Maintenance Procedures - Isolating Each UPS System**.
Using appropriate safety equipment and procedures, these components can be serviced while one of the two systems remains energized.

4.2.8 Maintenance Procedures - Tie Control Logic Components

Unless the controls are momentarily in a parallel mode or currently in the process of transferring a load, it is possible to service the Tie controls by taking a few precautions. Since all control signals are isolated, they can be safely de-energized for maintenance without affecting the UPS systems.

4.2.9 Abnormal Operations

Improper Transfer

Transfers can not be performed unless the OK TO TRANSFER LOAD (#) TO SYSTEM (#) light turns on. This makes it difficult to begin an improper transfer.

The source feeding the UPS modules does not matter because the UPS inverter output is isolated from the rectifier.

The logic permits transfers to and from a UPS system with the UPS modules running on Utility, Battery, or Engine-generator so long as the system accepting the load is running on inverter output.

Synchronization is verified by forcing the system to meet three independent criteria. First, all on-line module oscillators must be synchronized. Second, the voltage zero crossings must be within tolerance. Third, the instantaneous voltage differential between UPS system voltages must be within tolerance. But, regardless of synchronization status, a critical load will not be allowed to transfer to a system running on its bypass source. Transfers from a bypass source to a system on UPS is permitted.

Circuit Breaker Failure

If a “Close” or “Open” command to a circuit breaker fails to return a confirmation of completion within an acceptable time period the Power-Tie logic initiates corrective actions based on the system’s initial state and current state.

Loss of Tie Controls

Since UPS system independence has been stressed throughout the design of this Power-Tie configuration, complete loss of Tie Controls will not affect either UPS system operating in any Momentary Tie (Combined Loads Mode) configuration.

4.2.10 Trouble Recovery

While failures are extremely unlikely, the Power-Tie system has been designed to restart from any system operating mode once the fault has been corrected. Refer to **1.5.4 - Modes of Operation** for a description of the operating modes.

4.2.11 Isolation for Maintenance

See **Figure 8**.

Once the critical loads are transferred to the desired UPS, the maintenance bypass circuit breakers and isolation circuit breakers may be operated. The details of these isolation/maintenance operations are dependent on the specific arrangement of your switchboards. Typically, to assist maintenance personnel, maintenance circuit breaker operation is further guided by an electrical or electromechanical interlock system.

For detailed instructions for use of the maintenance bypass switchboard, refer to the Operation and Maintenance Manual for your Liebert Series 610 UPS.

Figure 8 Power-Tie system one-line diagram

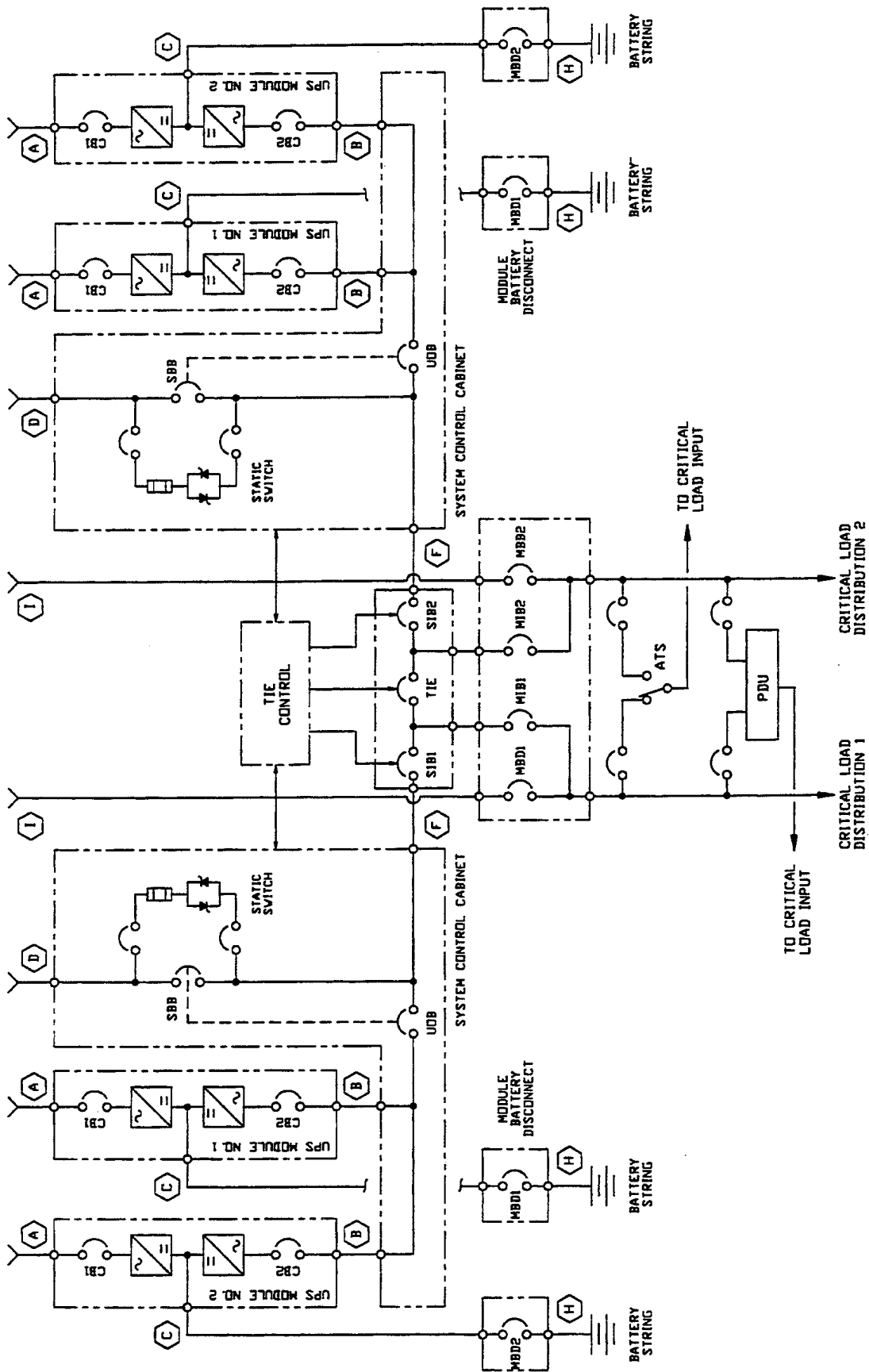

		TITLE ONE - LINE DIAGRAM POWER TIE SYSTEM	
DATE 02/22/94	TITLE		

4.2.12 Operation Scenarios/Transfer Procedures

Refer to the section listed below each figure for the operational procedure to perform the function indicated.

Figure 9 From start-up to normal operation, loads to be split between two distribution feeders

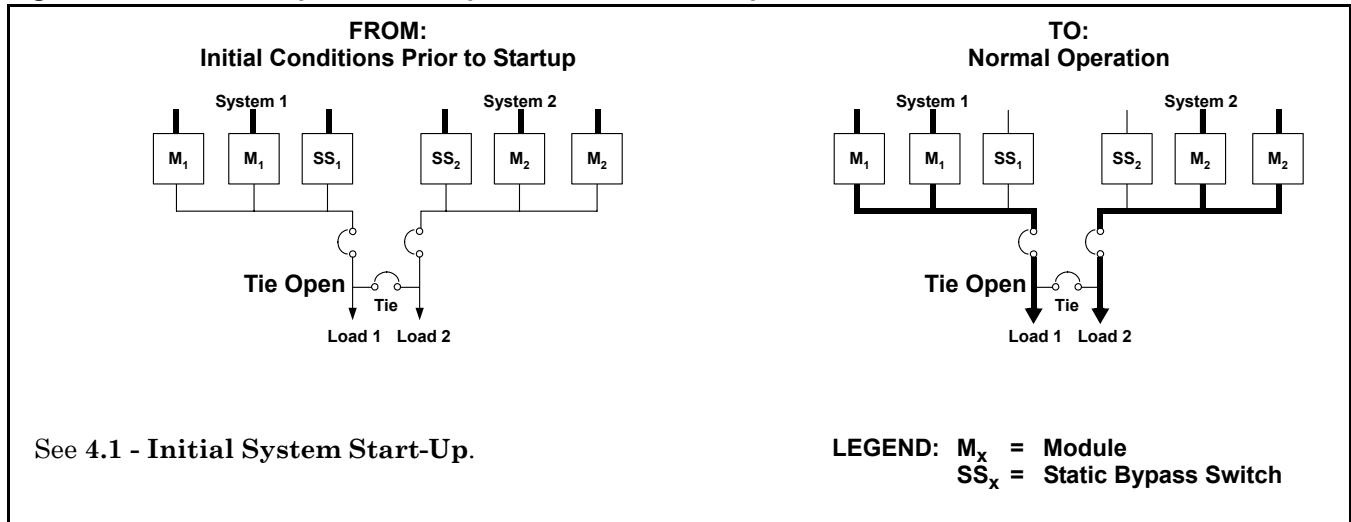

Figure 10 From combined loads operation to loads split between two feeders

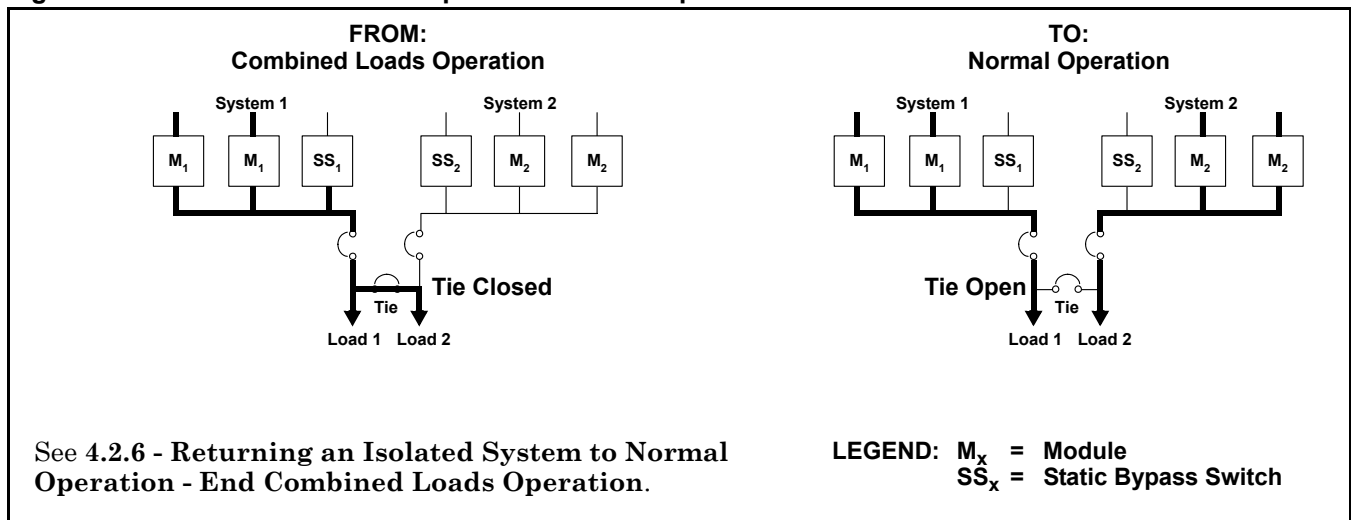

Figure 11 Transfer both load feeders to one UPS

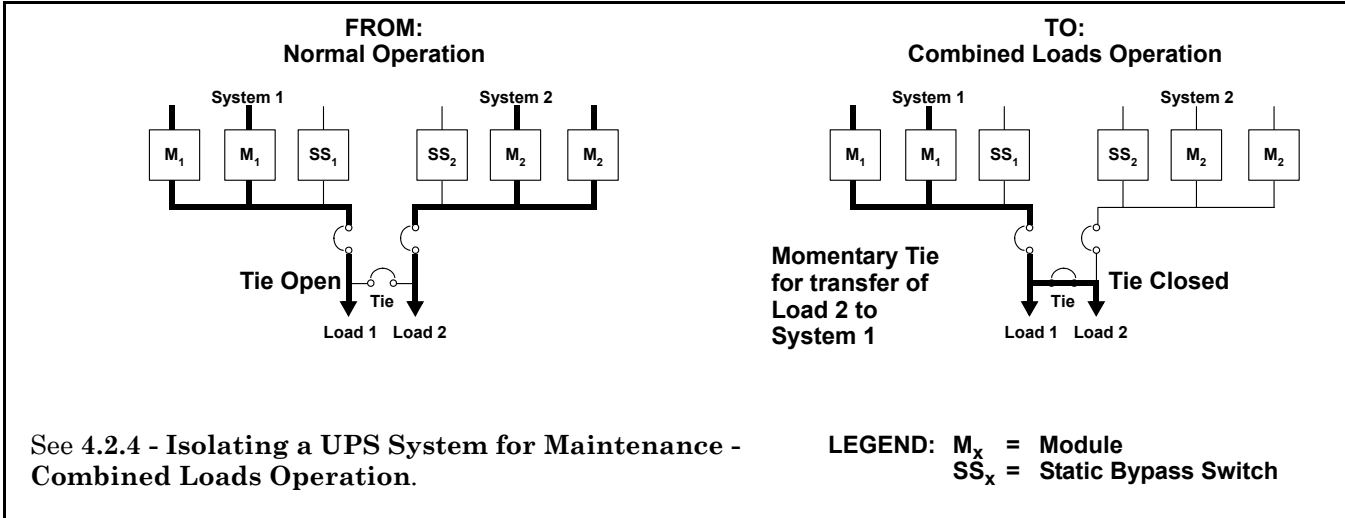

Figure 12 Both feeders on one system to normal operation

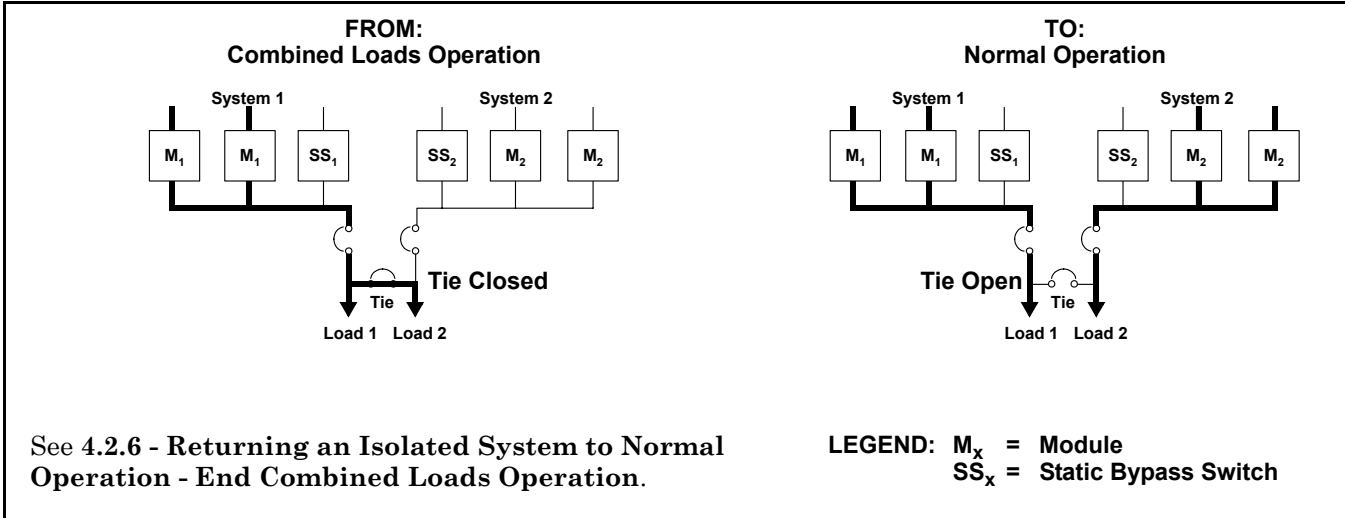

Figure 13 Transfer 100% load on one system to 100% load on a second system (a two-step operation)

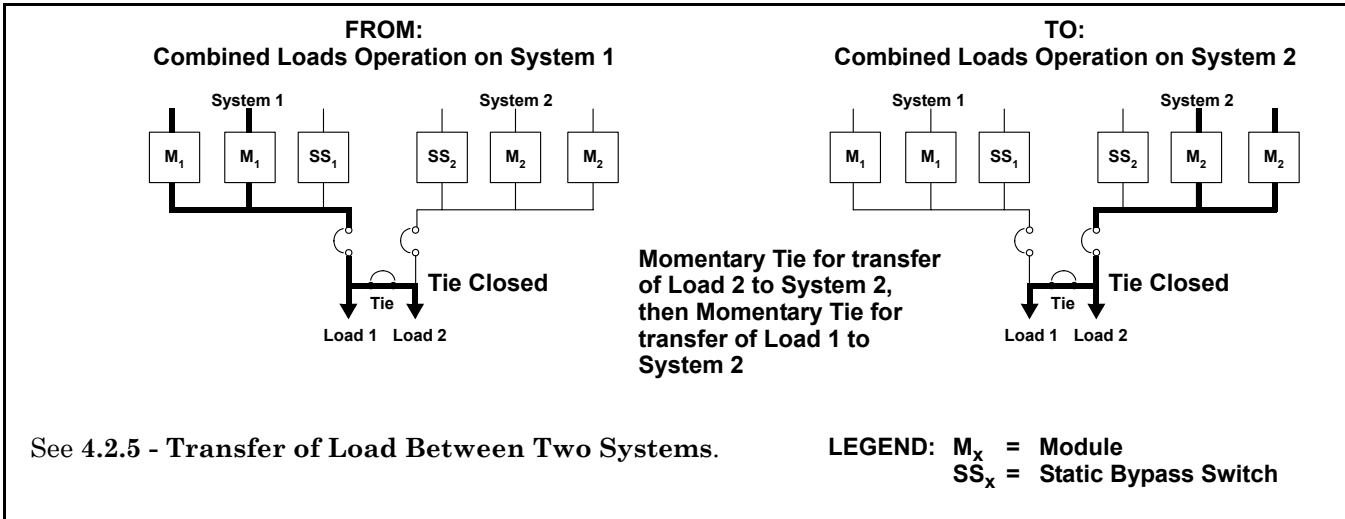
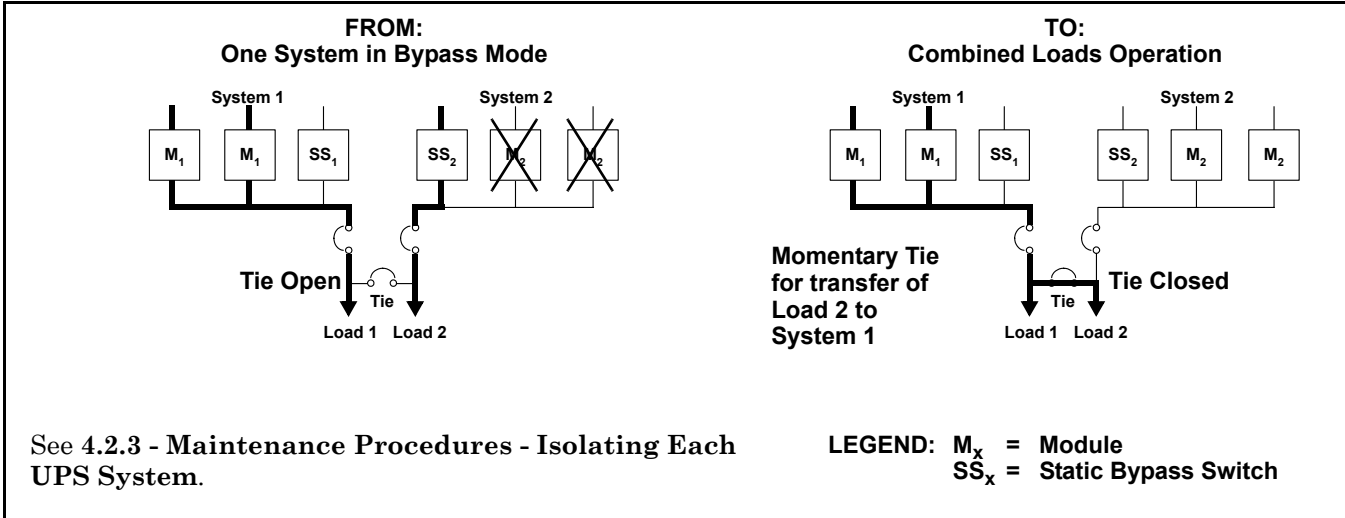

Figure 14 One system in bypass to both feeders combined on remaining operational system



NOTES

**DISCONTINUED
PRODUCT**

MOMENTARY POWER-TIE CONFIGURATION

USER MANUAL

The Company Behind the Products

With over a million installations around the globe, Liebert is the world leader in computer protection systems. Since its founding in 1965, Liebert has developed a complete range of support and protection systems for sensitive electronics:

- Environmental systems—close-control air conditioning from 1 to 60 tons
- Power conditioning and UPS with power ranges from 300 VA to more than 1000 kVA
- Integrated systems that provide both environmental and power protection in a single, flexible package
- Monitoring and control—from systems of any size or location, on-site or remote
- Service and support through more than 100 service centers around the world and a 24/7 Customer Response Center

While every precaution has been taken to ensure the accuracy and completeness of this literature, Liebert Corporation assumes no responsibility and disclaims all liability for damages resulting from use of this information or for any errors or omissions.

© 2005 Liebert Corporation

All rights reserved throughout the world. Specifications subject to change without notice.

® Liebert and the Liebert logo are registered trademarks of Liebert Corporation. All names referred to are trademarks or registered trademarks of their respective owners.

SL-30040 (12/05) Rev. 1

Technical Support/Service

Web Site

www.liebert.com

Monitoring

800-222-5877

monitoring@liebert.com

Outside the US: 614-841-6755

Single-Phase UPS

800-222-5877

upstech@liebert.com

Outside the US: 614-841-6755

Three-Phase UPS

800-543-2378

powertech@liebert.com

Environmental Systems

800-543-2778

Outside the United States

614-888-0246

Locations

United States

1050 Dearborn Drive

P.O. Box 29186

Columbus, OH 43229

Italy

Via Leonardo Da Vinci 8

Zona Industriale Tognana

35028 Piove Di Sacco (PD)

+39 049 9719 111

Fax: +39 049 5841 257

Asia

7/F, Dah Sing Financial Centre

108 Gloucester Road, Wanchai

Hong Kong

852 25722201

Fax: 852 28029250

**DISCONTINUED
PRODUCT**