



eSure™

DC/DC Converter Module

User Manual (UM1C400483500e), Revision J

Specification Number: 1C400483500e

Model Number: C400/48-3500e

The information contained in this document is subject to change without notice and may not be suitable for all applications. While every precaution has been taken to ensure accuracy and completeness herein, Vertiv Group Corp. assumes no responsibility, and disclaims all liability, for damages resulting from use of this information or for any errors or omissions. Refer to other local practices or building codes as applicable for the correct methods, tools, and materials to be used in performing procedures not specifically described in this document.

This document may contain confidential and/or proprietary information of Vertiv Group Corp., and its receipt or possession does not convey any right to reproduce, disclose its contents, or to manufacture or sell anything that it may describe. Reproduction, disclosure, or use without specific authorization from Vertiv Group Corp. is strictly prohibited.

Vertiv and the Vertiv logo are trademarks or registered trademarks of Vertiv Group Corp. All other names and logos referred to are trade names, trademarks or registered trademarks of their respective owners.

© 2019 Vertiv Group Corp. All rights reserved.

TABLE OF CONTENTS

Admonishments Used in this Document.....	4
Important Safety Instructions	5
General Safety	5
Voltages	5
DC Input Voltages.....	5
DC Output and Battery Voltages	5
Personal Protective Equipment (PPE).....	6
Hazardous Voltage	6
Handling Equipment Containing Static Sensitive Components.....	6
Static Warning.....	7
Introduction	9
Overview	9
Specifications	9
DC Output Ratings.....	9
DC Input Ratings.....	9
Environmental Ratings	10
Compliance Information.....	11
Standard Features.....	11
Mechanical Specifications.....	14
Operation	15
Local Indicators.....	15
Converter High Voltage Shutdown and Lockout Restart.....	15
Installing Converter Modules.....	16
Troubleshooting and Repair	18
Troubleshooting	18
Converter Current Sharing Imbalanced.....	18
Converter Fault Symptoms and Troubleshooting	18
Replacement Procedures.....	20
Converter Module Replacement.....	20
Converter Fan Replacement.....	21

ADMONISHMENTS USED IN THIS DOCUMENT



DANGER! Warns of a hazard the reader *will* be exposed to that will *likely* result in death or serious injury if not avoided. (ANSI, OSHA)



WARNING! Warns of a potential hazard the reader *may* be exposed to that *could* result in death or serious injury if not avoided. This admonition is not used for situations that pose a risk only to equipment, software, data, or service. (ANSI)



CAUTION! Warns of a potential hazard the reader *may* be exposed to that *could* result in minor or moderate injury if not avoided. (ANSI, OSHA) This admonition is not used for situations that pose a risk only to equipment, data, or service, even if such use appears to be permitted in some of the applicable standards. (OSHA)



ALERT! Alerts the reader to an action that *must be avoided* in order to protect equipment, software, data, or service. (ISO)



ALERT! Alerts the reader to an action that *must be performed* in order to prevent equipment damage, software corruption, data loss, or service interruption. (ISO)



FIRE SAFETY! Informs the reader of fire safety information, reminders, precautions, or policies, or of the locations of fire-fighting and fire-safety equipment. (ISO)



SAFETY! Informs the reader of general safety information, reminders, precautions, or policies not related to a particular source of hazard or to fire safety. (ISO, ANSI, OSHA)

IMPORTANT SAFETY INSTRUCTIONS

General Safety



DANGER! YOU MUST FOLLOW APPROVED SAFETY PROCEDURES.

Performing the following procedures may expose you to hazards. These procedures should be performed by qualified technicians familiar with the hazards associated with this type of equipment. These hazards may include shock, energy, and/or burns. To avoid these hazards:

- a) The tasks should be performed in the order indicated.
- b) Remove watches, rings, and other metal objects.
- c) Prior to contacting any uninsulated surface or termination, use a voltmeter to verify that no voltage or the expected voltage is present. Check for voltage with both AC and DC voltmeters prior to making contact.
- d) Wear eye protection.
- e) Use certified and well maintained insulated tools. Use double insulated tools appropriately rated for the work to be performed.
- f) For systems operating with 400 VDC power, do not work on an energized system without full arc flash and PPE protection.

Voltages

DC Input Voltages



DANGER! This system operates from 400 VDC input voltage capable of producing fatal electrical shock.

DC Output and Battery Voltages



DANGER! This system produces DC power and may have a battery source connected to it. Although the DC voltage is not hazardously high, the converters and/or battery can deliver large amounts of current. Exercise extreme caution not to inadvertently contact or have any tool inadvertently contact an output terminal or battery terminal or exposed wire connected to an output terminal or battery terminal. NEVER allow a metal object, such as a tool, to contact more than one termination or battery terminal at a time, or to simultaneously contact a termination or battery terminal and a grounded object. Even a momentary short circuit can cause sparking, explosion, and injury.

Personal Protective Equipment (PPE)



DANGER! ARC FLASH AND SHOCK HAZARD.

Appropriate PPE and tools required when working on this equipment. An appropriate flash protection boundary analysis should be done determine the “hazard/risk” category, and to select proper PPE.



This product is intended only for installation in a Restricted Access Location.

Only authorized and properly trained personnel should be allowed to install, inspect, operate, or maintain the equipment.

Do not work on LIVE parts. If required to work or operate live parts, obtain appropriate Energized Work Permits as required by the local authority, per NFPA 70E “Standard for Electrical Safety in the Workplace”.

Hazardous Voltage



DANGER! HAZARD OF ELECTRICAL SHOCK.

More than one disconnect may be required to de-energize the system before servicing.

Handling Equipment Containing Static Sensitive Components



ALERT! Installation or removal of equipment containing static sensitive components requires careful handling. Before handling any equipment containing static sensitive components, read and follow the instructions contained on the Static Warning Page.

STATIC WARNING



This equipment contains static sensitive components. The warnings listed below must be observed to prevent damage to these components. Disregarding any of these warnings may result in personal injury or damage to the equipment.

1. Strictly adhere to the procedures provided in this document.
2. Before touching any equipment containing static sensitive components, discharge all static electricity from yourself by wearing a wrist strap grounded through a one megohm resistor. Some wrist straps have a built-in one megohm resistor; no external resistor is necessary. Read and follow wrist strap manufacturer's instructions outlining use of a specific wrist strap.
3. Do not touch traces or components on equipment containing static sensitive components. Handle equipment containing static sensitive components only by the edges that do not have connector pads.
4. After removing equipment containing static sensitive components, place the equipment only on static dissipative surfaces such as conductive foam or ESD bag. Do not use ordinary Styrofoam™ or ordinary plastic.
5. Store and ship equipment containing static sensitive components only in static shielding containers.
6. If necessary to repair equipment containing static sensitive components, wear an appropriately grounded wrist strap, work on a conductive surface, use a grounded soldering iron, and use grounded test equipment.

This page is intentionally blank.

INTRODUCTION

Overview

The C400/48-3500e is a compact DC/DC converter which offers efficient power conversion. It operates from a nominal +400Vdc source to provide nominal -48Vdc load power.

Specifications

DC Output Ratings

- Voltage: Nominal -48 volts DC, positive ground. Output voltage is adjustable from -42 to -58 volts DC via the associated controller.
- Nameplate Rating: -48 to -58Vdc, 3500W.
- Regulation:
 - a) Output Voltage Tolerance: $< \pm 0.6\%$ when the load is 5%-100% and the temperature is 25°C.
 - b) Dynamic Response: The dynamic response time at rated input and output voltage is $\leq 200\mu\text{s}$ and overshoot $\leq 5\%$ for load changes at 50%-25%-50% and 50%-75%-50%.
 - c) The output voltage is accurate at half load. At half load, the error of output voltage is $\leq \pm 100\text{mV}$. Static regulation will give other voltage depending on load. The default value at half load is 53.5V.
- Filtering:
 - a) Wideband noise is $< 20\text{mV}$ between 25Hz-20kHz.
 - b) Peak-peak voltage is $\leq 250\text{mV}$ at 0-100MHz and normal output voltage.
 - c) Psophometric noise voltage is $\leq 2\text{mV}$ at 300-3400Hz.
 - d) Wideband noise voltages are $\leq 50\text{mV}$ at 3.4 kHz-150 kHz and $\leq 20\text{mV}$ at 0.15MHz-30MHz.
 - e) Discrete noise voltages are $\leq 5\text{mV}$ at 3.4-150 KHz, $\leq 3\text{mV}$ at 150-200 KHz, $\leq 2\text{mV}$ at 200-500KHz, and $\leq 1\text{mV}$ at 500-30000 KHz.
- Output over Current Protection: The converter has an appropriate fuse in the negative output.

DC Input Ratings

- Rated Input Voltage Range: 260Vdc to 400Vdc.
- Inrush Current: The peak value of the inrush current does not exceed 1.5 times the rated input steady-state peak value.
- Static Line Regulation: $\leq \pm 0.1\%$ over the operating nominal input voltage range at nominal frequency. Output voltage static regulation with temperature variation meets the temperature coefficient.
- Temperature Coefficient: $\leq \pm 0.02\%/^{\circ}\text{C}$ over the specified operating temperature range.
- Input Voltage Protection: The converter will shut down at low or high voltage input. Refer to the following:
 - a) Low Voltage Disable Point: 255Vdc \pm 5Vdc; hysteretic at least 15Vdc for restart.

- b) High Voltage Disable Point: 405Vdc±5Vdc; hysteretic at least 10Vdc for restart.
- Typical Input Data: When equipped with one DC-DC converter.
 - a) See **Table 1**.
 - b) Maximum Input Current: 14.6A_{dc} maximum @ 260Vdc input voltage, 3500 Watt output.
 - c) Efficiency: The efficiency is 96.5% at 30%-70% load when the input voltage is 380V and output voltage is 54V.

Table 1: Typical Input Data

Input Voltage	Percent of Full Load	Input Current (Amps)	Efficiency (%)	Typical Heat Dissipation (BTU/Hr)
380 VDC	10	0.92	92.53	82.9
	20	1.84	95.85	95.38
	30	2.76	96.86	109.17
	40	3.72	96.92	143.77
	50	4.68	96.87	183.45
	60	5.60	97.10	204.16
	70	6.56	96.83	260.9
	80	7.52	96.71	310.15
	90	8.48	96.55	366.16
	100	9.48	96.18	450.03

 **NOTE!** The output voltage of the DC-DC converter is initially adjusted to 48 volts DC at 50% load and 380 volts DC input.

Environmental Ratings

- Operation Temperature Range: -40°C to +75°C (-40°F to +167°F), -20°C to +45°C (-4°F to +113°F) with full performance.
- Storage Ambient Temperature Range: -40°C to +70°C (-40°F to +158°F).
- Humidity: This converter is capable of operating in an ambient relative humidity range of 0 to 95%, non-condensing.
- Altitude: The maximum operating ambient temperature should be derated by 3°C per 1000 feet at an elevation of 6,000 feet.
- Ventilation Requirements: The converter is fan cooled and utilizes front to back forced ventilation.
- Audible Noise: With a single converter installed and operating, the audible noise measured in front of converter at a 0.6m distance from a horizontal line from the middle of converter does not exceed 50 dBA with a temperature of 25°C.
- Over Voltage Category: II.
- Power Distribution System: TN/TT/IT.



NOTE! The converter is recommended to be used in an environment with Pollution of Degree 2 or less. Pollution Degree 2 applies where there is only non-conductive pollution that might temporarily become conductive due to occasional condensation (such as the office environment).

Compliance Information

- Safety Compliance: This unit meets the requirements of UL 60950-1, Standard for Information Technology Equipment, and is UL Recognized as a power supply for use in Telephone, Electronic Data Processing or Information Processing Equipment.
- EMC: This unit meets EN300 386:2001, Class A, other than Telecom centers.
- EFT: This unit meets EN61000-4-4, EFT will be fulfilled for DC terminals at 4KV (CM) with criteria B and signal line at 1KV (CM) with criteria B.
- ESD: This unit meets EN61000-4-2; requirements are 4KV air for criteria A 6KV contact and 8KV air for criteria B.
- Radiated Electrical Fields: This unit meets EN61000-4-3. 10V/m in the frequency range 80MHZ-1GHZ and 1.4-2GHZ with criteria A will be fulfilled.
- Power Frequency Magnetic Field: This unit meets EN61000-4-8. 30A/m magnetic field at 50Hz will be fulfilled for criteria A.
- Radiated Emission: For electrical field, meets EN55022 Class A between 30MHZ-1GHZ. For a standalone converter the levels are 6db below the class A limits.
- Climatic Environment:
 - a) Transportation: Meets ETS 300 019-1-2, Class 2.3.
 - b) Storage and Handling: Meets ETS 300 019-1-1, Class 1.2.
 - c) Operation: Meets ETS 300 019-1-3, Class 3.2.
 - d) Transportation, Storage and Handling, Operation: Meets Telcordia GR-63-Core, Chapter 4.

Standard Features

- Type of Power Conversion Circuit: High Frequency.
- Input Voltage Protection:
 - a) Fusing: A non-user replaceable fuse is located in the positive and negative input lead of each DC-DC converter.
 - b) High and Low Input Voltage Inhibit: The converter shuts down at low or high input voltage.
 1. Low Voltage Disable Point: 255Vdc \pm 5Vdc; hysteretic at least 15Vdc for restart.
 2. High Voltage Disable Point: 405Vdc \pm 5Vdc; hysteretic at least 10Vdc for restart.
- Output Protection:
 - a) Overvoltage Protection: When output voltage goes above a preset value (59.5 \pm 0.5V, not to exceed 60V for more than 50ms), the converter shuts down. Software settable HVSD level (from controller) 56V-59V.

- b) Power Limit: Output power is limited to 3500W.
- c) Over Temperature Protection: The operation of a DC-DC converter will automatically shut down and lock out if the internal temperature of the module exceeds a predetermined value. Operation will automatically resume after the over-temperature condition is corrected.
- Series Paralleling Output FET: A series paralleling output FET is provided in each DC-DC converter. This allows the modules to be paralleled for redundancy.
- Hot Swappable: The converter is designed to be plug-and-play. The converter can be inserted or removed from a live DC power system with no damage. When the converter is plugged into the system, the system output voltage will not be affected.
- Cooling: Each converter contains a fan for forced convection cooling.
 - a) Fan Fault Protection: The converter shuts down and its alarm indicator (red) flashes if the fan fails. Fan failure is detected and reported to controller. The fan is field replaceable.
 - b) Fan Control: Fan speed is continuously variable. When input voltage is within normal range, the built-in processor adjusts fan speed according to the converter's output power. For example, a higher output power increases the fan speed.
- Communication Failure: The protection indicator (yellow) will flash should communication between the converter and associated system controller fail. The failure information will be reported to the associated system controller and the controller will process the failure accordingly. During a communication failure, the converter output voltage will automatically adjust to 48.00Vdc. The converter will revert to normal operation once normal communication is restored.
- Monitoring Function: The converter has a built-in advanced DSP (Digital Signal Processor) that monitors and controls the operation of the converter. The DSP also communicates with the associated system controller in real time through the CAN bus. **Table 2** lists the different commands and information exchanged between the converter and the controller.
- External Alarm: Provided via the associated controller. Refer to the separate power system documentation for a description of available external alarms.
- Battery Management Function: The converter can receive commands from controller to realize battery management function such as charge current limit, temperature compensation, equalize, float, discharge test and so on.
- Walk-in Function: The rise time of the converter output voltage is > 8s at 90% of the rated load, and the maximum time is 124s at 100% of the rated load.

The feature is selectable (on/off) and configurable in seconds through the controller.

Table 2: Monitoring Function

Commands / signals that can be received by the Converter from the Controller.	Information gathered by the Controller from the Converter.
<ul style="list-style-type: none"> • Turn On/Off • HVSD Reset • Current Limit Adjustment • Voltage Adjustment • Fan Speed Control Enable/Disable • HVSD Threshold 	<ul style="list-style-type: none"> • Output Voltage • Output Current • Current Limit Setting • Temperature • Over Voltage Setting • On/Off Status • Fault Alarms, such as: <ul style="list-style-type: none"> • HVSD • Fan Fail • EEPROM Failure • Protection Alarms, such as: <ul style="list-style-type: none"> • Input Voltage Protection • High Temperature Protection • Thermal Derating • Address • Code • Date • Software Version • Hardware Version

- Interval Start Function: The time period between starting each converter in the system can be set via controller. It reduces the inrush current which draw from the 400V power and improve the stabilization of the whole system.
- Power Derating Based on Temperature: The converter delivers full power when operating at an ambient temperature of +45°C (+113°F) or below. Each converter continuously monitors the ambient temperature surrounding the power conversion circuit. If this temperature for any reason (such as a high ambient temperature or failed fan) increase above approximately +45°C (+113°F), the converter will not shut down. Rather, the converter limits its maximum output power to maintain the temperature of the power conversion circuit within design parameters. Operation between +45°C (+113°F) and +75°C (+158°F) will result in output power being decreased. Full power capability is restored when the temperature decreases to below approximately +45°C (+113°F). Refer to **Figure 1** to review the relationship between the output power and the ambient temperature.

WARNING! The module is rated for continuous operation at full output power up to +45°C (+113°F). Operation between +45°C (+113°F) and +75°C (158°F) will result in output power decreasing. Operation above +75°C (+158°F) is considered abnormal and should be used on a temporary¹ basis only.

- ¹ Temporary Operation at Abnormal Temperature: Temporary operation refers to a period of not more than eight consecutive hours per day, and a total of not more than 15 days in a year. (This refers to a total of 120 hours in any given year, but no more than 15 occurrences in that one year period.)

Figure 1: Typical Thermal Power Limit Curve

**C400/48-3500e Output power vs. Temperature
at 400Vdc ≥ Vin ≥ 290 Vdc**

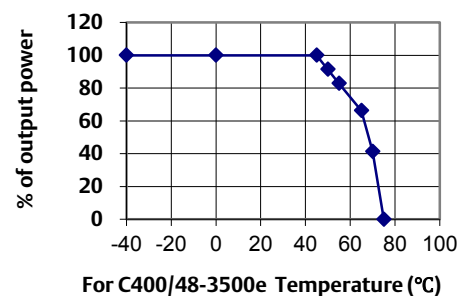

Mechanical Specifications

- Weight: 3.5kg (7.7 lbs).
- Dimensions (H x W x D): 5.20" (132mm) x 3.36" (85.3mm) x 11.3" (287mm).
- Local Controls: None.
- Local Status and Alarm Indicators:
 - a) Power (Green)
 - b) Protection (Yellow)
 - c) Alarm (Red)

OPERATION

Local Indicators

Location and Identification: Refer to **Figure 2**.

Description: There are three (3) indicators located on the converter's front panel. The functions of these indicators are as shown in **Table 3**.

 **NOTE!** DC voltage must be present at the converter output terminals (from battery or an operating converter) or DC voltage at the input terminals.

Converter High Voltage Shutdown and Lockout Restart

Procedure

Remove the converter, wait 30 seconds or more (until the LEDs on the converter extinguish), then re-insert the converter.

The converter may also be restarted from the controller. Refer to the controller's documentation.

Figure 2: Local Indicator Locations

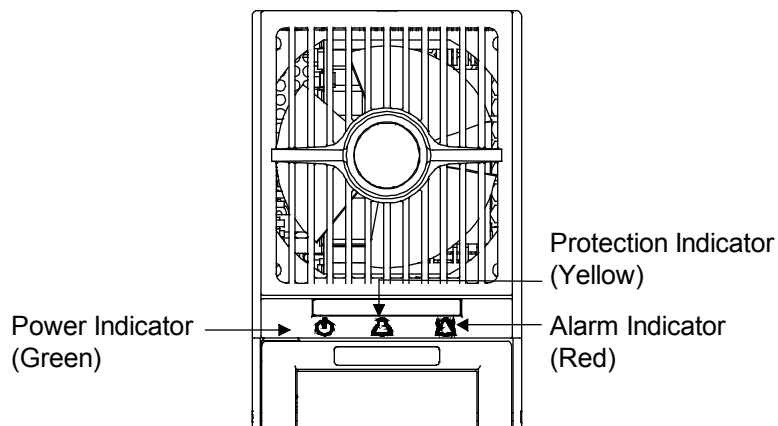







Table 3: DC-DC Converter Indicators

Indicator		Normal State	Alarm State	Alarm Cause
	Power (Green)	On	Off	No input voltage. Internal input fuse open.
			Flashing	The converter is being identified by the controller.
	Protection (Yellow)	Off	On	DC input under/over voltage. PFC over-voltage. Moderate load sharing imbalance. Converter not inserted into the slot completely. Converter over-temperature protection. Converter in ECO Standby Mode when ECO Mode is active in controller.
			Flashing	Loss of communication with the controller (the converter can provide power). Input voltage is AC.
	Alarm (Red)	Off	On	Severe load sharing imbalance. Converter output disabled for any reason, including overvoltage shutdown and internal output fuse open. Converter addresses contradictory.
			Flashing	Fan not operating (converter shuts down).

Installing Converter Modules

Converters can be inserted or removed with power applied (hot swappable).

 **NOTE!** Each converter locks into a module mounting shelf by means of a latch located on the underside of the converter module. The latch and converter module handle are interactive. Push the handle into the converter module's front panel, and the latch will pop out from the converter module bottom. Click the handle to pop it out from the converter module's front panel, and the latch will retract back into the converter module. The latch mechanism is shown in **Figure 3**.

 **CAUTION!** This converter contains double pole/neutral fusing. Parts of the equipment that remain energized might represent a hazard during servicing after operation of the fuse. This fuse is not customer replaceable.

 **WARNING!** To prevent damage to the latching mechanism, ensure the handle is in the open position when installing or removing a converter module. NEVER hold the handle in the closed position when installing a converter into a shelf.

Procedure



NOTE! Refer to **Figure 3** as this procedure is performed.

1. Unpack the module.
2. If present, remove blank cover panels from the module mounting positions into which converter modules are to be installed.
3. Place the module into an unoccupied mounting slot without sliding it in completely.
4. Push the converter module handle in and release in order to pop it forwards out of the converter module's front panel (this will also retract the latch mechanism located on the underside of the converter module).
5. Push the converter module completely into the shelf.
6. Push the handle into the front panel of the converter module. This will also cause the latch mechanism located on the underside of the converter module to lock the converter module securely to the shelf.
7. Repeat the above steps for each converter module being installed in the system.
8. After the converter modules are physically installed in the mounting shelf(s), they are ready for operation immediately after power is supplied to them.
9. Certain functions (i.e. converter current limit, converter addressing) may require adjustment when adding or replacing a converter module. Refer to the power system documentation for instructions.

Figure 3: Installing Converter

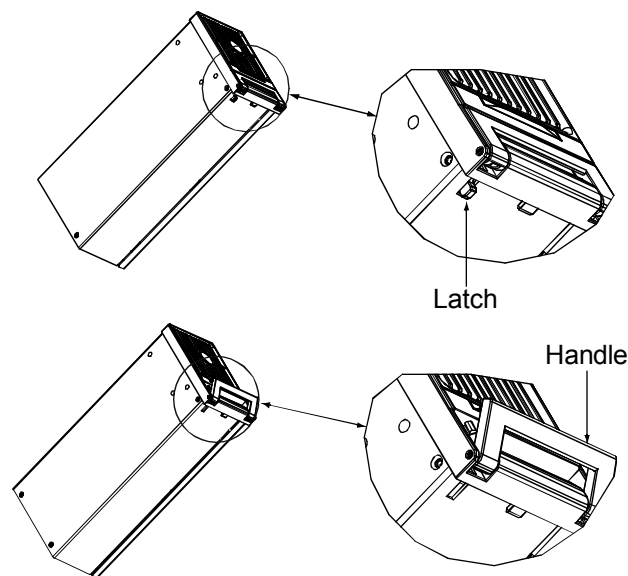

TROUBLESHOOTING AND REPAIR

Troubleshooting

Converter Current Sharing Imbalanced

When multiple converters are operating in parallel and the load is greater than 10%, if the current sharing imbalance among them is greater than 3%, check if the converter is properly seated in the shelf.



If the current sharing imbalance still persists following the verification suggested above, replace the converter exhibiting the current imbalance.

Converter Fault Symptoms and Troubleshooting

The fault indicators that can be displayed by the converter are as follows. Refer to **Table 4** for a list of possible causes and corrective actions.

- Power Indicator (Green) OFF
- Protection Indicator (Yellow) ON
- Protection Indicator (Yellow) Flashing
- Alarm Indicator (Red) ON
- Alarm Indicator (Red) Flashing

Table 4: Converter Troubleshooting

Symptom		Possible Cause(s)	Suggested Action(s)
	Power Indicator (Green) Off	No input voltage.	Make sure there is input voltage.
		Internal input fuse open.	Replace the converter.
	Protection Indicator (Yellow) On	DC input under/over voltage.	Correct the DC input voltage to within the acceptable range.
		PFC over-voltage.	Replace the converter.
		Moderate load sharing imbalance.	Check if the converter is properly seated in the module mounting assembly. If this does not correct the fault, replace the converter.
		Converter not inserted into the slot completely.	Remove and properly insert the converter.
		Converter over-temperature protection.	Fan rotor blocked: remove any object that may be blocking the fan. Ventilation blocked (inlet or outlet): remove any object that may be blocking the inlet or outlet. Ambient temperature too high or rectifier inlet too close to a heat source: lower the ambient temperature or relocate the heat source.
	Converter in ECO Standby Mode when ECO Mode is active in controller.	--	
	Protection Indicator (Yellow) Flashing	Loss of communication with controller (the converter can provide power).	Check the communication cables. Remove and properly insert the converter.
Input voltage is AC.		Correct the input voltage.	
	Alarm Indicator (Red) On	Severe load sharing imbalance. Converter output disabled for any reason, including overvoltage shutdown and internal output fuse open.	Remove the converter, wait 30 seconds or more (until the LEDs on the converter extinguish), then re-insert the converter. If converter fails to start, shuts down again, or load sharing imbalance persists; replace the converter.
		Converter addresses contradictory.	Replace the converter.
	Alarm Indicator (Red) Flashing	Fan not operating (converter shuts down).	Replace the fan.

Replacement Procedures

Converter Module Replacement

Converter modules can be inserted or removed with power applied (hot swappable).

 **NOTE!** Each converter locks into a module mounting shelf by means of a latch located on the underside of the converter module. The latch and converter module handle are interactive. Push the handle into the converter module's front panel, and the latch will pop out from the converter module bottom. Click the handle to pop it out from the converter module's front panel, and the latch will retract back into the converter module. The latch mechanism is shown in **Figure 3**

 **DANGER!** Take care when removing a converter that was in operation, as converter surfaces could be very hot.

 **WARNING!** To prevent damage to the latching mechanism, ensure the converter module handle is in the open position when installing or removing a converter module. NEVER hold the handle in the closed position when installing a converter into a shelf.

Procedure

 **NOTE!** Refer to **Figure 3** as this procedure is performed.

1. Performing this procedure may activate external alarms. Do one of the following. If possible, disable these alarms. If these alarms cannot be easily disabled, notify the appropriate personnel to disregard any alarms associated with this system while this procedure is performed.
2. On the converter module to be removed, push the converter module handle in and release in order to pop it forwards out of the converter module's front panel (this will also retract the latch mechanism located on the underside of the converter module). Refer to **Figure 3**.
3. Slide the converter out by pulling forwards.
4. Place the replacement converter module into the mounting position without sliding it in completely.
5. On the replacement converter module, push the converter module handle in and release in order to pop it forwards out of the converter module's front panel (this will also retract the latch mechanism located on the underside of the converter module). Refer to **Figure 3**.
6. Push the converter module completely into the shelf.
7. Push the handle into the front panel of the converter module. This will also cause the latch mechanism located on the underside of the converter module to lock the converter module securely to the shelf.
8. Certain functions (i.e. converter current limit, converter addressing) may require adjustment when adding or replacing a converter module. Refer to the power system documentation for instructions.
9. After the converter modules are physically installed in the mounting shelf(s), they are ready for operation immediately after power is supplied to them. Verify that the converter modules are operating normally.
10. Enable the external alarms, or notify appropriate personnel that this procedure is finished.
11. Ensure that there are no local or remote alarms active on the system.

Converter Fan Replacement

Each converter uses a fan (P/N 32010109) for cooling. If fan replacement should become necessary, perform the following procedure.

Refer to **Figure 4** as this procedure is performed.

 **NOTE!** When performing any step in this procedure that requires removal of existing hardware, retain all hardware for use in subsequent steps.

Procedure

1. Performing this procedure may activate external alarms. Do one of the following. If possible, disable these alarms. If these alarms cannot be easily disabled, notify the appropriate personnel to disregard any alarms associated with this system while this procedure is performed.
2. Remove the converter from the shelf. Refer to a previous procedure for step-by-step instructions.
3. On this converter; remove the front panel by removing the screws securing the front panel to the chassis, and by unplugging the fan from the printed circuit card.
4. For proper orientation of the new fan, observe the location of the fan wires and the air flow arrows on the old fan.
5. Remove the old fan from the front panel by removing the three screws and clips securing the fan.
6. Install the new fan onto the front panel using the two screws and clips previously removed. Ensure the fan wires and air flow arrows match the orientation of the old fan.
7. Install the front panel with the new fan onto the chassis by plugging the fan cable into the printed circuit card, and securing the front panel with the screws previously removed.
8. Replace the converter into the shelf. Refer to the previous procedure for step-by-step instructions.
9. Enable the external alarms, or notify appropriate personnel that this procedure is finished.
10. Ensure that there are no local or remote alarms active on the system.

Figure 4: Fan Replacement

