



## Rectifier Module

User Manual (UM1R243000), Revision J

Specification Number: 1R242500, 1R243000

Model Number: R24-2500, R24-3000

The information contained in this document is subject to change without notice and may not be suitable for all applications. While every precaution has been taken to ensure accuracy and completeness herein, Vertiv Group Corp. assumes no responsibility, and disclaims all liability, for damages resulting from use of this information or for any errors or omissions. Refer to other local practices or building codes as applicable for the correct methods, tools, and materials to be used in performing procedures not specifically described in this document.

This document may contain confidential and/or proprietary information of Vertiv Group Corp., and its receipt or possession does not convey any right to reproduce, disclose its contents, or to manufacture or sell anything that it may describe. Reproduction, disclosure, or use without specific authorization from Vertiv Group Corp. is strictly prohibited.

Vertiv and the Vertiv logo are trademarks or registered trademarks of Vertiv Group Corp. All other names and logos referred to are trade names, trademarks or registered trademarks of their respective owners.

© 2019 Vertiv Group Corp. All rights reserved.

# TABLE OF CONTENTS

<b>Admonishments Used in this Document.....</b>	<b>4</b>
<b>Important Safety Instructions .....</b>	<b>5</b>
General Safety .....	5
Voltages .....	5
AC Input Voltages.....	5
DC Output and Battery Voltages .....	5
Hazardous Voltage.....	5
Handling Equipment Containing Static Sensitive Components.....	5
<b>Static Warning.....</b>	<b>6</b>
<b>Introduction .....</b>	<b>7</b>
Overview.....	7
Specifications .....	7
DC Output Ratings.....	7
AC Input Ratings.....	9
Environmental Ratings.....	11
Compliance Information.....	12
Standard Features.....	12
Mechanical Specifications.....	15
<b>Operation.....</b>	<b>16</b>
Local Indicators.....	16
Rectifier High Voltage Shutdown and Lockout Restart.....	16
Installing Rectifier Modules.....	18
<b>Troubleshooting and Repair .....</b>	<b>19</b>
Troubleshooting .....	19
Rectifier Current Sharing Imbalance.....	19
Rectifier Module Fault Symptoms and Troubleshooting.....	19
Replacement Procedures.....	21
Rectifier Module Replacement.....	21
Rectifier Module Fan Replacement.....	22

## ADMONISHMENTS USED IN THIS DOCUMENT



**DANGER!** Warns of a hazard the reader *will* be exposed to that will *likely* result in death or serious injury if not avoided. (ANSI, OSHA)



**WARNING!** Warns of a potential hazard the reader *may* be exposed to that *could* result in death or serious injury if not avoided. This admonition is not used for situations that pose a risk only to equipment, software, data, or service. (ANSI)



**CAUTION!** Warns of a potential hazard the reader *may* be exposed to that *could* result in minor or moderate injury if not avoided. (ANSI, OSHA) This admonition is not used for situations that pose a risk only to equipment, data, or service, even if such use appears to be permitted in some of the applicable standards. (OSHA)



**ALERT!** Alerts the reader to an action that *must be avoided* in order to protect equipment, software, data, or service. (ISO)



**ALERT!** Alerts the reader to an action that *must be performed* in order to prevent equipment damage, software corruption, data loss, or service interruption. (ISO)



**FIRE SAFETY!** Informs the reader of fire safety information, reminders, precautions, or policies, or of the locations of fire-fighting and fire-safety equipment. (ISO)



**SAFETY!** Informs the reader of general safety information, reminders, precautions, or policies not related to a particular source of hazard or to fire safety. (ISO, ANSI, OSHA)

# IMPORTANT SAFETY INSTRUCTIONS

## General Safety



**DANGER!** YOU MUST FOLLOW APPROVED SAFETY PROCEDURES.

Performing the following procedures may expose you to hazards. These procedures should be performed by qualified technicians familiar with the hazards associated with this type of equipment. These hazards may include shock, energy, and/or burns. To avoid these hazards:

- a) The tasks should be performed in the order indicated.
- b) Remove watches, rings, and other metal objects.
- c) Prior to contacting any uninsulated surface or termination, use a voltmeter to verify that no voltage or the expected voltage is present. Check for voltage with both AC and DC voltmeters prior to making contact.
- d) Wear eye protection.
- e) Use certified and well maintained insulated tools. Use double insulated tools appropriately rated for the work to be performed.

## Voltages

### AC Input Voltages



**DANGER!** This system operates from AC input voltage capable of producing fatal electrical shock.

### DC Output and Battery Voltages



**DANGER!** This system produces DC power and may have a battery source connected to it. Although the DC voltage is not hazardously high, the rectifiers and/or battery can deliver large amounts of current. Exercise extreme caution not to inadvertently contact or have any tool inadvertently contact an output terminal or battery terminal or exposed wire connected to an output terminal or battery terminal. NEVER allow a metal object, such as a tool, to contact more than one termination or battery terminal at a time, or to simultaneously contact a termination or battery terminal and a grounded object. Even a momentary short circuit can cause sparking, explosion, and injury.

## Hazardous Voltage



**DANGER!** HAZARD OF ELECTRICAL SHOCK.

More than one disconnect may be required to de-energize the system before servicing.

## Handling Equipment Containing Static Sensitive Components



**ALERT!** Installation or removal of equipment containing static sensitive components requires careful handling. Before handling any equipment containing static sensitive components, read and follow the instructions contained on the Static Warning Page.

## STATIC WARNING



This equipment contains static sensitive components. The warnings listed below must be observed to prevent damage to these components. Disregarding any of these warnings may result in personal injury or damage to the equipment.

1. Strictly adhere to the procedures provided in this document.
2. Before touching any equipment containing static sensitive components, discharge all static electricity from yourself by wearing a wrist strap grounded through a one megohm resistor. Some wrist straps have a built-in one megohm resistor; no external resistor is necessary. Read and follow wrist strap manufacturer's instructions outlining use of a specific wrist strap.
3. Do not touch traces or components on equipment containing static sensitive components. Handle equipment containing static sensitive components only by the edges that do not have connector pads.
4. After removing equipment containing static sensitive components, place the equipment only on static dissipative surfaces such as conductive foam or ESD bag. Do not use ordinary Styrofoam™ or ordinary plastic.
5. Store and ship equipment containing static sensitive components only in static shielding containers.
6. If necessary to repair equipment containing static sensitive components, wear an appropriately grounded wrist strap, work on a conductive surface, use a grounded soldering iron, and use grounded test equipment.

# INTRODUCTION

## Overview

The rectifiers provide load power, battery float current, and battery recharge current during normal operating conditions. The rectifiers are a constant power design. The rectifiers are rated at their maximum output power. This means that, within the normal operating ambient temperature range and input voltage range, the maximum output power available is a constant 2500W (R24-2500) or 3000W (R24-3000). Within these ranges, the rectifier operate in one of three modes, depending upon load demands. Transition between modes is completely automatic. If ambient temperature rises above or input voltage falls below acceptable values, rectifiers continue to operate but at derated output power levels.

- Constant Voltage Mode: For any initial output voltage setting from 23.5 to 28.5 volts, output voltage remains constant regardless of load. This is the normal operating condition, in which loads are supplied and batteries are float charged. Rectifiers operate in the Constant Voltage Mode unless load increases to the point where the product of load current and output voltage is approximately 2500W (R24-2500) or 3000W (R24-3000).
- Constant Power Mode: As load increases above approximately 2500W (R24-2500) or 3000W (R24-3000) (non-adjustable), output current continues to increase, but output voltage decreases as required to maintain constant output power. Rectifiers operate in the Constant Power Mode unless load continues to increase to the point where the current limit setting is reached.
- Constant Current Mode: If load increases to the current limit setting, output voltage decreases linearly to maintain output current at the current limit setting.

## Specifications

### DC Output Ratings

- Voltage: Nominal +24 volts DC, Negative Ground. Output voltage is adjustable from 23.50 to 28.50 volts DC via the associated controller.
- Current (One 2500W Rectifier Module): 87.7A at 28.5VDC to 104.2A at 24.0VDC.
- Current (One 3000W Rectifier Module): 105.3A at 28.5VDC to 125.0A at 24.0VDC.
- Power (One Rectifier Module): 2500W or 3000W at  $V_{out} \geq 24VDC$ .
- Output Characteristics: The relationship between output voltage and current is depicted graphically in the following illustrations.

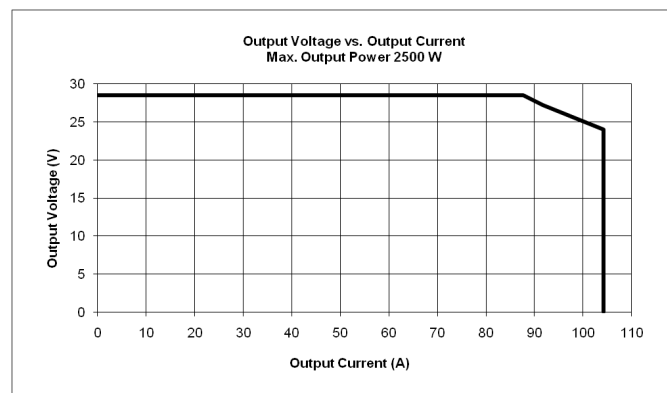

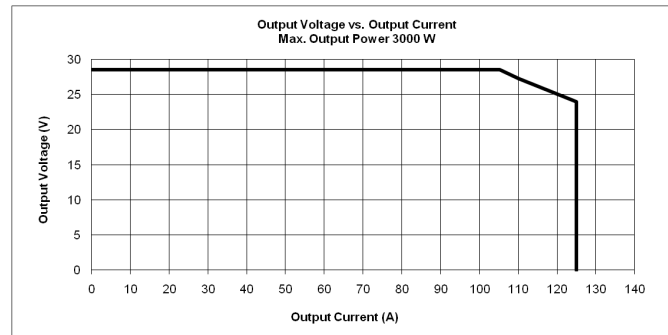

- Power Derating Based on Input Voltage:** The rectifier can provide maximum rated power (2500W or 3000W) as long as the input voltage is within the range of 180 to 275 VAC. From 180 VAC to 90 VAC, the rectifier will continue to operate, but maximum power is reduced. The relationship between the output power and input voltage is illustrated below.

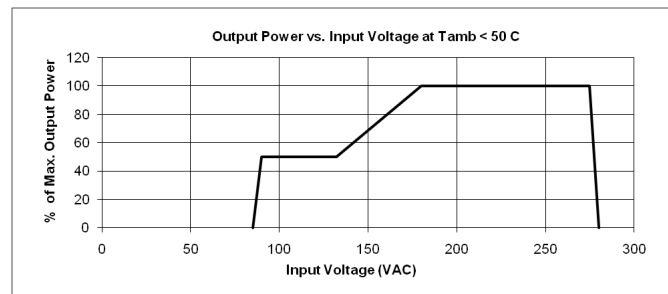

- Power Derating Based on Temperature:** Each rectifier continuously monitors the ambient temperature surrounding the power conversion circuit. If this temperature for any reason (such as a high ambient temperature or failed fan) increases above approximately +50°C (+122°F), the rectifier will not shut down. Rather, the rectifier limits its maximum output power to maintain the temperature of the power conversion circuit within design parameters. Operation between +50°C (+122°F) and +65°C (149°F) will result in the output power being decreased linearly to 80% of full rated power at +65°C (149°F). Full power capability is restored when the temperature decreases to below approximately +50°C (+122°F). Refer to the following curve illustrating typical operating parameters.

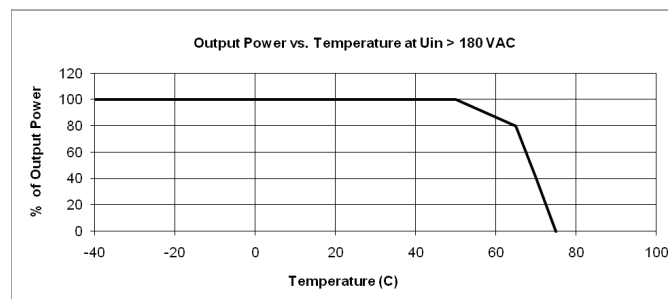





**WARNING!** The module is rated for continuous operation at full output power up to +50°C (+122°F). Operation between +50°C (+122°F) and +65°C (+149°F) will result in output power decrease. Operation above +65°C (+149°F) is considered abnormal and should be used on a temporary<sup>1</sup> basis only.

<sup>1</sup> Temporary Operation at Abnormal Temperature: Temporary operation is defined as a period of not more than eight consecutive hours per day, and a total of not more than 15 days in a year. (This refers to a total of 120 hours in any given year, but no more than 15 occurrences in that one-year period.)

- Regulation:
  - a) Static: Steady state regulation is  $\pm 0.5\%$  as controlled within the rectifier for any and all combinations of load from no load to full load, input voltage, and input frequency at a constant ambient temperature. The associated system controller may provide improved regulation.
  - b) Dynamic Load: For any step load change within the range of 10% to 90% of full load within 50 microseconds, per Telcordia GR-947-CORE, the maximum voltage transient will not exceed  $\pm 5\%$  of the initial steady state voltage within 250 microseconds. Recovery to within 1% of the initial steady state voltage does not exceed 4 milliseconds.
  - c) Dynamic Line: Any step change of line voltage within the specified operating range shall not cause the output voltage to deviate outside the  $\pm 0.5\%$  regulation band.
- Filtering (with or without battery): Typical readings were taken at nominal input voltage, nominal output voltage, 50% load, and 25°C (77°F) ambient.
  - a) Voice Band Noise: Complies with Telcordia GR-947-CORE.
    1. Typically 30 dB<sub>rn</sub> with C-message weighting. Does not exceed 32 dB<sub>rn</sub> C.
    2. Typically 0.6 millivolt psophometric. Does not exceed 1 millivolt psophometric.
  - b) Wide Band Noise: Complies with Telcordia GR-947-CORE.
    1. Typically 80 millivolts peak-to-peak. Does not exceed 250 millivolts peak-to-peak.
    2. Typically 6.3 millivolts rms. Does not exceed 50 millivolts rms.

## AC Input Ratings

- Voltage:
  - a) Normal: Nominal 208-240 volts AC, single phase, 50/60 Hz, with an operating range of 180 to 264 volts. Acceptable input frequency range is 47 to 65 Hz.
  - b) Reduced Output: The rectifier operates and provides reduced output power from 180 to 90 volts.
  - c) Extended: The rectifier operates safely to 275 volts AC.
  - d) Safe Voltage: The rectifier tolerates 300 volts AC without damage.
- Harmonic Content: Meets EN 61000-3-2.
- Inrush Current: Peak does not exceed 2 times the RMS input current at full load, nominal input voltage, and for any duration of AC input interrupts. Under the above conditions, standard AC distribution circuit breakers will not trip.

- Typical Input Data (1R242500): 60 Hz Input

a) System output is initially adjusted to 27.24 volts DC as measured at the system sense points at 50% of full load and nominal input. “Percent of Full Load” refers to percent of 87.7A at 28.5V.

Nominal Input Voltage	Percent of Full Load	Input Current (Amperes)	Input VA	Input Watts	Power Factor %	Efficiency %	Heat Dissipation BTU/Hr
208	0	0.3166	65.9478	21.1692	32.1	--	72.23
	25	3.376	703.896	696.153	98.9	85.93	334.11
	50	6.406	1330.53	1327.87	99.8	90.18	445.11
	75	9.495	1973.06	1971.09	99.9	90.84	615.79
	100	12.683	2639.33	2636.69	99.9	90.57	848.46
	110	13.683	2839.22	2833.54	99.8	90.26	942.01
	120	13.69	2846.15	2840.46	99.8	89.74	994.54
240	0	0.3433	82.4263	19.535	23.7	--	66.66
	25	2.956	708.258	691.259	97.6	86.51	318.16
	50	5.551	1327.8	1322.49	99.6	90.59	424.57
	75	8.288	1975.86	1971.91	99.8	91.15	595.74
	100	11.054	2625.33	2622.7	99.9	91.07	799.42
	110	11.885	2819.12	2816.3	99.9	90.95	869.93
	120	11.875	2827.44	2824.61	99.9	90.27	937.98

b) Maximum Input Current: 15.43A at 100% of full load with output adjusted to 28.5 volts DC as measured at the shelf output terminals, and input voltage of 180 volts.

- Typical Input Data (1R243000): 60 Hz Input

a) System output is initially adjusted to 27.24 volts DC as measured at the system sense points at 50% of full load and nominal input. “Percent of Full Load” refers to percent of 105.3A at 28.5V.

Nominal Input Voltage	Percent of Full Load	Input Current (Amperes)	Input VA	Input Watts	Power Factor %	Efficiency %	Heat Dissipation BTU/Hr
208	0	0.308	64.22	15.83	24.67	--	53.81
	25	3.819	795.63	787.42	98.97	91.05	239.65
	50	7.361	1532.2	1529.2	99.81	93.75	324.91
	75	11.057	2299.3	2296.4	99.88	93.56	503.09
	100	14.835	3082.1	3077	99.84	93.00	732.76
	110	16.165	3357.7	3351.5	99.81	92.61	842.20
	120	16.253	3375.7	3369.5	99.81	92.03	912.86
240	0	0.344	82.94	14.55	17.58	--	49.45
	25	3.334	801.78	784.97	97.91	91.18	235.50
	50	6.372	1531.2	1525.7	99.64	93.87	318.19
	75	9.537	2289.9	2286.9	99.87	93.89	475.13
	100	12.77	3064.1	3060.8	99.9	93.46	680.27
	110	13.908	3336.8	3333.1	99.89	93.14	777.23
	120	13.981	3354.1	3350.4	99.89	92.54	849.45

b) Maximum Input Current: 18.3A at 100% of full load with output adjusted to 28.5 volts DC as measured at the shelf output terminals, and input voltage of 180 volts.

### Environmental Ratings

- Operating Ambient Temperature Range: -40°C to +75°C (-40°F to +167°F).
- Specification Compliant Temperature Range:
  - a) R24-2500: -20°C to +70°C (-4°F to +158°F).
  - b) R24-3000: -20°C to +65°C (-4°F to +149°F).
- Reduced Load Temperature Range: +50°C to +75°C (+122 to +167°F).
- Storage Ambient Temperature Range: -40°C to +85°C (-40°F to +185°F).
- Relative Humidity: This rectifier is capable of operating in an ambient relative humidity range of 0% to 95%, non-condensing.
- Altitude: This rectifier is capable of operating in an altitude range of -200 feet to 10,000 feet. The maximum operating ambient temperature should be de-rated by 3°C per 1000 feet above 5000 feet.
- Surge Protection: Compliance with EN61000-4-5 Installation Class 4, and capable of withstanding surges per ANSI/IEEE C 62.41 1980 Category B3 across the input terminals.



**NOTE!** This level of protection is a widely used standard for telecommunications power equipment. As with all such equipment, it is the end user's responsibility to provide an adequately sized Surge Suppression Device at the commercial power service entrance of the building that reduces all incoming surges to levels below the classes/categories stated for the equipment.

- Ventilation Requirements: The rectifier is fan cooled and utilizes front to back forced ventilation. A rectifier must be mounted so ventilating openings are not blocked and temperature of the air entering the rectifier does not exceed the Operating Ambient Temperature Range stated above.
- Single Rectifier Audible Noise: The audible noise at any point two feet from any vertical surface of a Rectifier Mounting Shelf (with one rectifier installed and fans operating) does not exceed the following limits. The audible noise was measured with the fan control circuit enabled. A Sound Level Meter conforming to ANSI S1.4 was used.
  - a) 50dB-A maximum at less than 32°C ambient, half load or less.
  - b) 60dB-A maximum at less than 32°C ambient, full load.
  - c) 70dB-A maximum at greater than 32°C ambient, full load.
- EMI/RFI Suppression: Rectifier operating in an approved Module Mounting Shelf conform to the requirements of FCC rules Part 15, Subpart B, Class B for Radiated and Conducted emissions limits.

### Compliance Information

- Safety Compliance: This unit meets the requirements of UL 60950-1, Standard for Information Technology Equipment, and is UL Recognized as a power supply for use in Telephone, Electronic Data Processing or Information Processing Equipment. This unit meets the requirements of CAN/CSA 22.2, No. 60950-00 and is tested and Certified by UL ("c UR") as a Component Type Power Supply.
- The rectifier is RoHS 5/6 compliant.
- NEBS Compliance (when used in a compliant system): Compliance verified by a Nationally Recognized Testing Laboratory (NRTL) per GR-1089-CORE and GR-63-CORE. Contact Vertiv for NEBS compliance reports.

### Standard Features

- Type of Power Conversion Circuit: High frequency.
- Constant Voltage Mode: For any initial output voltage setting from 23.5 to 28.5 volts, output voltage remains constant regardless of load. This is the normal operating condition, in which loads are supplied and batteries are float charged. Rectifiers operate in the Constant Voltage Mode unless load increases to the point where the product of load current and output voltage is approximately 2500W (R24-2500) or 3000W (R24-3000).
- Constant Power Mode: As load increases above approximately 2500W (R24-2500) or 3000W (R24-3000) (non-adjustable), output current continues to increase, but output voltage decreases as required to maintain constant output power. Rectifiers operate in the Constant Power Mode unless load continues to increase to the point where the current limit setting is reached.
- Constant Current Mode: If load increases above the current limit setting, output voltage decreases linearly to maintain output current at current limit.

- Input Protection:
  - a) Fusing: The rectifier contains double pole/neutral fusing (non user-replaceable). Customer is to provide AC input branch circuit protection.
  - b) Low Input Voltage: The rectifier shuts down and its protection indicator (yellow) illuminates if input voltage decreases below 85VAC. The rectifier automatically restarts when the input voltage returns to within the normal operating range. A low input voltage condition does not trip the recommended input protection device.
  - c) High Input Voltage: The rectifier shuts down and its protection indicator (yellow) illuminates if input voltage increases above 280VAC. The rectifier automatically restarts when the input voltage returns to within the normal operating range.
  - d) Power Interruption: Interruption and restoration of input power does not affect the proper operation of the controls, alarm signals, or visual indicators. On restoration of input power, the rectifier automatically restarts without manual intervention and without operating protective devices, even if connected to a completely discharged battery string or capacitor bank.
  
- Output Protection:
  - a) Current Limiting: The maximum current delivered by the rectifier can be programmed from 10% to 120% of full load rating via the controller. If communication to the controller is lost, the rectifier default value is 121% of full load rating. Full load rating for rectifier is defined as the maximum current available over the entire output voltage range (88A for R24-2500, 104A for R24-3000). The rectifier can start when connected to a completely discharged battery or capacitor bank without operating rectifier protective devices or needing any manual intervention.
  - b) Fusing: The rectifier contains an output fuse (non user-replaceable). Rectifier output power is lost and its fault indicator (red) illuminates if the output fuse opens. The rectifier can be plugged into or pulled out of a shelf while operating, without damage or opening the fuse.
  - c) High Voltage Shutdown:
    1. Adjustable Control: If rectifier output voltage exceeds an adjustable preset value and the rectifier is delivering more than 10% of its rated current, the rectifier shuts down. (Adjustable from 24.00 VDC to 29.75 VDC via the controller. The restart hysteresis is 0.5 V  $\pm$ 0.2 V.)

The rectifier then restarts and a HVSD restart timer starts (time value configurable via the controller, factory default is 5 minutes). If output voltage again exceeds the high voltage shutdown value before the HVSD restart timer expires, the rectifier shuts down and locks out. Manual restart is then required (by turning power to the rectifier off or by removing the rectifier, waiting until the LEDs on the rectifier extinguish, then turning power to the rectifier on or re-inserting the rectifier). If the rectifier does not experience a high voltage condition before the HVSD restart timer expires, the restart circuit is reset.

If two or more rectifiers are paralleled, only the rectifier causing the high voltage condition shuts down.
    2. Backup: If rectifier output voltage exceeds 31.0 V  $\pm$ 0.5 V (non-adjustable) and the rectifier is delivering more than 10% of its rated current, the rectifier shuts down. The rectifier then restarts and a HVSD restart timer starts (time value configurable via the controller, factory default is 5 minutes). If output voltage again exceeds the high voltage shutdown value before

the HVSD restart timer expires, the rectifier shuts down and locks out. Manual restart is then required (by turning power to the rectifier off or by removing the rectifier, waiting until the LEDs on the rectifier extinguish, then turning power to the rectifier on or re-inserting the rectifier).

- Over-Temperature Protection: The rectifier provides over temperature protection by derating output power and recovers automatically.
- Hot Swappable: The rectifier is designed to be plug-and-play. The rectifier can be inserted or removed from a live DC power system with no damage. When the rectifier is plugged into the system, the system output voltage will not be affected.
- Power Factor Correction Failure: If the power factor correction circuit fails and results in over/low DC bus voltage, the rectifier shuts down and its protection indicator (yellow) illuminates.
- Rectifier Module DC/DC Converter Failure: If the rectifier's DC/DC converter fails, the rectifier shuts down and the fault indicator (red) illuminates.
- Rectifier Module Load Sharing (per Bay): The rectifier shares load with other like rectifiers operating in parallel on one CAN communications bus to within  $\pm 3\%$  of the ratings of the rectifiers when between 10%~100% load (maximum 28 rectifiers).

If R24-2500 and R24-3000 rectifiers are operating in the same system, they will share load at the ratio of their output power ratings.

- Startup Time: The rectifier has two startup modes.
  - a) Normal Startup:
    - Start up time, defined as beginning at AC input being applied and ending when full output power has been reached, consists of two time intervals, the delay period and the output voltage ramp up period.
    - During the delay period the output voltage will be zero.
    - Start up time (from AC on until full power):  $\leq 5$  seconds.
    - Output voltage ramp up period,  $t$ :  $50 \leq t \leq 150$  ms. (10% to 90% of full power) (if walk-in feature is disabled).
    - The rise time is retained with a DC load of 0.31 Ohm (+24.0VDC & 87.7A).
    - The rectifier will not suffer any damage when subjected to repetitive AC voltage on / off operations.
  - b) Output Voltage Walk-In: Meets Telcordia GR-947-CORE, R3-19. Output voltage gradually increases after AC service is supplied or restored. Ramp-up time is settable via the controller. The controller can enable/disable this feature.
- Cooling: Each rectifier contains two fans for forced convection cooling.
  - a) Fan Fault Protection: The rectifier shuts down and its fault indicator (red) flashes if either fan fails. Fan failure is detected and reported to controller. The fans are field replaceable.
  - b) Fan Control: Fan speed is continuously variable. When input voltage is within normal range, the built-in processor adjusts fan speed according to the rectifier's internal temperature and output power. For example, a higher temperature or output power increases the fan speed. Fan speed control can be disabled by the controller.

- Communication Failure: The rectifier's protection indicator (yellow) will flash should it experience a communication failure. The failure information will be reported to the controller and the controller will process the failure accordingly. During a communication failure, in order to protect the battery, the rectifier output voltage will automatically be adjusted as follows.
  - The rectifier default factory output voltage is 27.24V.
  - Once power is applied to the rectifier and the rectifier is recognized by the controller, the output voltage is updated to the setting programmed into the controller.
  - If communications with an SCU+ controller is lost, rectifier output voltage goes to a default value programmed into the controller (this is a separate programmable parameter from the output voltage setting).
  - If communications with an ACU+ or NCU controller is lost, rectifier output voltage goes to the last communicated float output voltage setting in the controller (the last communicated float output voltage setting is stored in the rectifier).
  - The rectifier will revert to normal operation once normal communication to the controller is restored.
- Output Current Imbalance:
  - a) When the average current of all rectifiers is greater than 20% of full rated current, and the difference between local rectifier current and average current is greater than 16% of full rated current, the yellow protection indicator will illuminate.
  - b) When the average current of all rectifiers is greater than 20% of full rated current, and local rectifier current is less than 2% of full rated current, then the red fault indicator will illuminate.
- Paralleling: This rectifier may be connected in parallel with any rectifier of the same polarity and adjusted to the same output voltage.
- Monitoring Function: The rectifier has a built-in advanced DSP (Digital Signal Processor) that monitors and controls the operation of the rectifier. The DSP also communicates with the associated system controller in real time through the CAN bus. **Table 1** lists the different commands and information exchanged between the rectifier and the controller.
- External Control Circuits: Provided via the associated controller. Refer to the separate Power System documentation for a complete description of available external control circuits.
- External Alarm Circuits: Provided via the associated controller. Refer to the separate Power System documentation for a description of available external alarms.

## Mechanical Specifications

- Weight: 6.4 lbs (2.9 kg).
- Dimensions (H x W x D): 1.63" (41.4mm) x 4.88" (124mm) x 14.96" (380mm).
- Local Controls: None.
- Local Status and Alarm Indicators:
  - a) Power (Green)
  - b) Protection (Yellow)
  - c) Alarm (Red)

**Table 1:**

Commands / signals that can be received by the Rectifier Module from the Controller.	Information gathered by the Controller from the Rectifier Module.
<ul style="list-style-type: none"> <li>• Turn On/Off</li> <li>• Voltage Walk-in On/Off</li> <li>• HVSD Reset</li> <li>• Current Limit Adjustment</li> <li>• Voltage Adjustment</li> <li>• Fan Speed Control Enable/Disable</li> </ul>	<ul style="list-style-type: none"> <li>• Input Voltage</li> <li>• Output Voltage</li> <li>• Output Current</li> <li>• Current Limit Setting</li> <li>• Temperature</li> <li>• Over Voltage Setting</li> <li>• On/Off Status</li> <li>• Fault Alarms, such as:               <ul style="list-style-type: none"> <li>HVSD</li> <li>Fan Fail</li> </ul> </li> <li>• Protection Alarms, such as:               <ul style="list-style-type: none"> <li>Input Voltage Protection</li> <li>Inner DC Bus Voltage Protection</li> <li>High Temperature Protection</li> </ul> </li> <li>• Thermal Derating</li> <li>• AC Derating</li> <li>• AC Fail</li> <li>• Imbalanced Output Current</li> <li>• Address</li> <li>• Code</li> <li>• Date</li> <li>• Software Version</li> <li>• Hardware Version</li> </ul>

## OPERATION

### Local Indicators

Location and Identification: Refer to **Figure 1**.

Description: There are three (3) indicators located on the rectifier’s front panel. The functions of these indicators are as shown in **Table 2**.

 **NOTE!** DC voltage must be present at the rectifier output terminals (from battery or an operating rectifier) or AC voltage at the input terminals for local indicators to illuminate.

### Rectifier High Voltage Shutdown and Lockout Restart

#### Procedure

1. Turn the power to the rectifier off or remove the rectifier, wait 30 seconds or more (until the LEDs on the rectifier extinguish), then turn the power to the rectifier on or re-insert the rectifier.



**Figure 1:** Local Indicator Locations

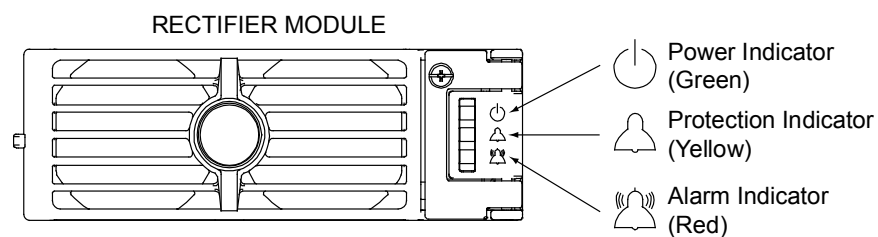

**Table 2:** Rectifier Module Indicators

Indicator		Normal State	Alarm State	Alarm Cause
	Power (Green)	On	Off	No input voltage. Internal input fuse open.
			Flashing	The rectifier is being identified by the controller.
	Protection (Yellow)	Off	On	AC input under/over voltage. PFC output under/over voltage. Moderate load sharing imbalance. Rectifier not inserted into the slot completely. Rectifier over-temperature protection. Rectifier in ECO Standby Mode when ECO Mode is active in controller.
			Flashing	Loss of communication with controller (the rectifier can provide power).
	Alarm (Red)	Off	On	Severe load sharing imbalance. Rectifier output disabled for any reason, including overvoltage shutdown and internal output fuse open. Rectifier addresses contradictory.
			Flashing	One or both fans not operating (rectifier shuts down).

## Installing Rectifier Modules

The rectifier is hot swappable. It can be installed with the system operating.

**WARNING!** To prevent damage to the latching mechanism, ensure the handle is in the open position when installing or removing a rectifier. NEVER hold the handle in the closed position when installing a rectifier into a shelf.

### Procedure

1. Place the module into an unoccupied mounting slot without sliding it in completely.
2. Loosen the captive screw on the module handle. Pull the handle to pivot it out of the module front panel (this will also retract the latch mechanism located at the right side of the module). Refer to **Figure 2** for latch mechanism illustration.
3. Push the rectifier completely into the shelf.
4. Push the handle into the front panel of the module. Tighten the captive screw on the handle. This will lock the module securely to the shelf.
5. Repeat the above steps for each rectifier being installed in the system.
6. After the rectifiers are physically installed in the mounting shelf(s), they are ready for operation immediately after power is supplied to them.
7. Certain functions (i.e. rectifier current limit, rectifier addressing) may require adjustment when adding or replacing a rectifier. Refer to the Power System documentation for instructions.

**Figure 2:** Rectifier Module Handle/Latch Mechanism

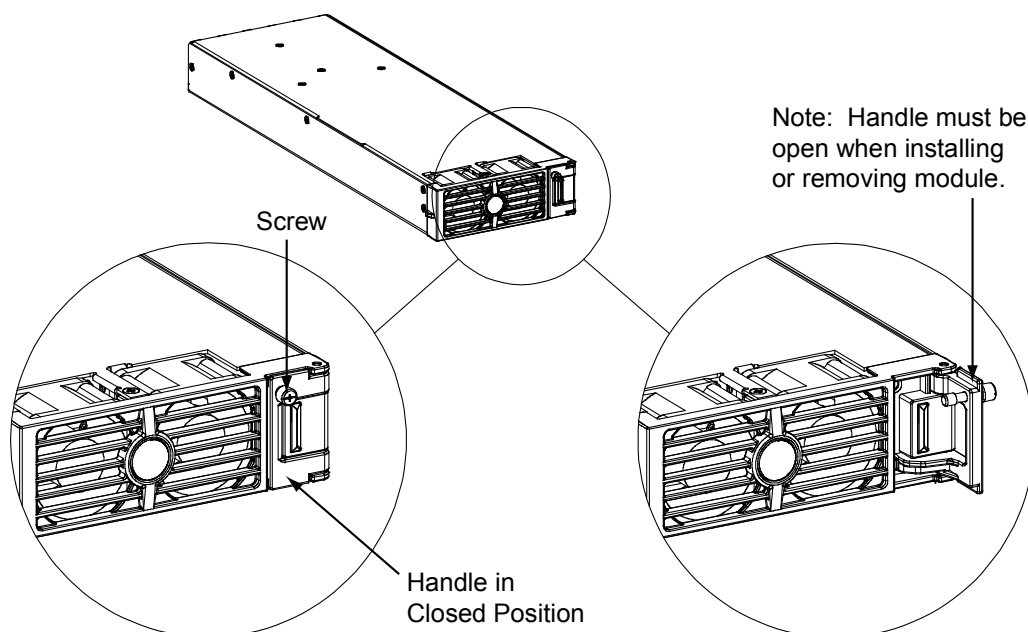

# TROUBLESHOOTING AND REPAIR

## Troubleshooting

### Rectifier Current Sharing Imbalance

When multiple rectifiers are operating in parallel and load is 10%-100%, then if the current sharing imbalance among them is greater than  $\pm 3A$  of the average rectifier current, check if the rectifier is properly seated in the shelf.



If the current sharing imbalance still persists following the verification suggested above, replace the rectifier exhibiting the current imbalance.

### Rectifier Module Fault Symptoms and Troubleshooting

The fault indicators that can be displayed by the rectifier are as follows. Refer to **Table 3** for a list of possible causes and corrective actions.

- Power Indicator (Green) OFF
- Protection Indicator (Yellow) ON
- Protection Indicator (Yellow) Flashing
- Alarm Indicator (Red) ON
- Alarm Indicator (Red) Flashing

**Table 3:** Rectifier Module Troubleshooting

Symptom		Possible Cause(s)	Suggested Action(s)
	Power Indicator (Green) Off	No input voltage.	Make sure there is input voltage.
		Internal input fuse open.	Replace the rectifier.
	Protection Indicator (Yellow) On	AC input under/over voltage.	Correct the AC input voltage to within the acceptable range.
		PFC under/over voltage.	Replace the rectifier.
		Moderate load sharing imbalance.	Check if the rectifier is properly seated in the module mounting assembly. If this does not correct the fault, replace the rectifier.
		Rectifier not inserted into the slot completely.	Remove and properly insert the rectifier.
		Rectifier over-temperature protection.	Fan rotor blocked: remove any object that may be blocking the fan. Ventilation blocked (inlet or outlet): remove any object that may be blocking the inlet or outlet. Ambient temperature too high or rectifier inlet too close to a heat source: lower the ambient temperature or relocate the heat source.
	Rectifier in ECO Standby Mode when ECO Mode is active in controller.	--	
	Protection Indicator (Yellow) Flashing	Loss of communication with controller (the rectifier can provide power).	Check the communication cables. Remove and properly insert the rectifier and controller.
	Alarm Indicator (Red) On	Severe load sharing imbalance. Rectifier output disabled for any reason, including overvoltage shutdown and internal output fuse open. Rectifier addresses contradictory.	Turn AC power to the rectifier off or remove the rectifier, wait 30 seconds or more (until the LEDs on the rectifier extinguish), then turn the AC power to the rectifier on or re-insert the rectifier. If rectifier fails to start, shuts down again, or load sharing imbalance persists; replace the rectifier.
	Alarm Indicator (Red) Flashing	One or both fans not operating (rectifier shuts down).	Replace the fan(s).

## Replacement Procedures

### Rectifier Module Replacement



**DANGER!** Take care when removing a rectifier module that was in operation, as rectifier module surfaces could be very hot.



**WARNING!** To prevent damage to the latching mechanism, ensure the handle is in the open position when installing or removing a rectifier. NEVER hold the handle in the closed position when installing a rectifier into a shelf.

The rectifier is hot swappable. It can be removed and installed with the system operating.

#### **Procedure**

1. Performing this procedure may activate external alarms. Do one of the following. If possible, disable these alarms. If these alarms cannot be easily disabled, notify the appropriate personnel to disregard any alarms associated with this system while this procedure is performed.
2. Loosen the captive screw on the module handle. Pull the handle to pivot it out of the module front panel (this will also retract the latch mechanism located at the right side of the module). Refer to **Figure 2** for latch mechanism illustration.
3. Grasp the handle and pull firmly to remove the module from the shelf.
4. Place the replacement Rectifier Module into the mounting position without sliding it in completely.
5. Loosen the captive screw on the module handle. Pull the handle to pivot it out of the module front panel (this will also retract the latch mechanism located at the right side of the module). Refer to **Figure 2** for latch mechanism illustration.
6. Push the rectifier completely into the shelf.
7. Push the handle into the front panel of the module. Tighten the captive screw on the handle. This will lock the module securely to the shelf.
8. Certain functions (i.e. rectifier current limit, rectifier addressing) may require adjustment when adding or replacing a rectifier. Refer to the Power System documentation for instructions.
9. After the Rectifiers are physically installed in the mounting shelf(s), they are ready for operation immediately after power is supplied to them. Verify that the Rectifiers are operating normally.
10. Enable the external alarms, or notify appropriate personnel that this procedure is finished.
11. Ensure that there are no local or remote alarms active on the system.

## Rectifier Module Fan Replacement

Each rectifier uses two fans (P/N 32010480) for cooling. If fan replacement should become necessary, perform the following procedure. It is recommended that both fans in the rectifier be replaced at the same time.

Refer to **Figure 3** as this procedure is performed.



**WARNING!** In a system with NO redundant rectifier, battery must have sufficient reserve to power the load(s) while the rectifier is removed for fan replacement.



**NOTE!** When performing any step in this procedure that requires removal of existing hardware, retain all hardware for use in subsequent steps.

### Procedure

1. Performing this procedure may activate external alarms. Do one of the following. If possible, disable these alarms. If these alarms cannot be easily disabled, notify the appropriate personnel to disregard any alarms associated with this system while this procedure is performed.
2. Remove the rectifier from the shelf. Refer to the previous procedure for step-by-step instructions.
3. Place the rectifier on a static-safe work surface. Connect an approved grounding strap to your wrist for the remainder of this procedure.
4. Remove the four (4) faceplate mounting screws shown in **Figure 3** from the rectifier. Remove the faceplate.
5. For proper orientation of the new fan(s), observe the location of the fan wires and the air flow arrows on the old fan(s).
6. Carefully pull the fan(s) out from the rectifier, until the fan power cable(s) can be accessed.
7. Unplug the fan power cable(s) from connector(s) on the PC board, and remove the fan(s).
8. Plug the power cable(s) of the replacement fan(s) into the connector(s) on the PC board.
9. Place the new fan(s) in the space vacated by the old fan(s) (ensure the fan wires and air flow arrows match the orientation of the old fan), and plug it into the rectifier.
10. Replace the faceplate on the rectifier. Note that each fan has four holes in the front corners and that the faceplate has four tabs per fan. When replacing the faceplate, align the fan holes with the faceplate tabs. Ensure that no fan wiring is pinched. Secure faceplate with the four (4) previously removed screws.
11. Replace the rectifier into the shelf. Refer to the previous procedure for step-by-step instructions.
12. When the fans start, check to ensure that each is providing front-to-back airflow. If air direction is wrong, immediately remove the rectifier from the shelf. Repeat previous steps to check fan orientation, and correct as necessary. Reinstall the rectifier and again check for proper airflow.
13. Enable the external alarms, or notify appropriate personnel that this procedure is finished.
14. Ensure that there are no local or remote alarms active on the system.

**Figure 3:** Rectifier Module Fan Replacement

