



NetSure™

V200D50 DC Power Retrofit

Installation and User Manual (UM486527803), Revision F

Specification Number: 486527803

Model Number: V200D50

The information contained in this document is subject to change without notice and may not be suitable for all applications. While every precaution has been taken to ensure the accuracy and completeness of this document, Vertiv Group Corporation assumes no responsibility and disclaims all liability for damages resulting from use of this information or for any errors or omissions. Refer to other local practices or building codes as applicable for the correct methods, tools, and materials to be used in performing procedures not specifically described in this document.

This document may contain confidential and/or proprietary information of Vertiv Group Corporation, and its receipt or possession does not convey any right to reproduce, disclose its contents, or to manufacture or sell anything that it may describe. Reproduction, disclosure, or use without specific authorization from Vertiv Group Corporation is strictly prohibited.

Vertiv and the Vertiv logo are trademarks or registered trademarks of Vertiv Group Corporation. NetPerform™, NetReach™, NetSure™ and NetXtend™ are trademarks of Vertiv Energy Systems, Inc. All other trademarks are the property of their respective owners.

© 2017 Vertiv Energy Systems, Inc. All rights reserved.

TABLE OF CONTENTS

Admonishments Used in this Document	4
Important Safety Instructions	5
General Safety	5
Personal Protective Equipment (PPE).....	5
Handling Equipment Containing Static Sensitive Components.....	5
Static Warning	6
Introduction	7
General.....	7
Specifications	7
DC Output Ratings.....	7
AC Input Ratings.....	9
Environmental Ratings.....	12
Standard Features.....	13
Installation	16
Safety Statement.....	16
Remove Style Strips from Power Bay.....	17
Remove the Power Conversion Unit (PCU) or Blank Cover Panel.....	17
Install the Mounting Frame.....	19
Install the Rectifiers.....	22
Install Remaining Retrofits in Power Bay.....	24
Reinstall Style Strips on Power Bay.....	24
Repeat Procedure for Remaining Power Bays.....	24
Final Step.....	24
Operation	25
Local Indicators.....	25
Rectifier High Voltage Shutdown and Lockout Restart.....	26
Troubleshooting and Repair	26
Troubleshooting	26
Replacement Procedures.....	27
Replacing a Rectifier.....	27
Replacing the Rectifier Interface Circuit Card.....	28
Replacing a Fan in a Rectifier	30

ADMONISHMENTS USED IN THIS DOCUMENT



DANGER! Warns of a hazard the reader *will* be exposed to that will *likely* result in death or serious injury if not avoided. (ANSI, OSHA)



WARNING! Warns of a potential hazard the reader *may* be exposed to that *could* result in death or serious injury if not avoided. This admonition is not used for situations that pose a risk only to equipment, software, data, or service. (ANSI)



CAUTION! Warns of a potential hazard the reader *may* be exposed to that *could* result in minor or moderate injury if not avoided. (ANSI, OSHA) This admonition is not used for situations that pose a risk only to equipment, data, or service, even if such use appears to be permitted in some of the applicable standards. (OSHA)



ALERT! Alerts the reader to an action that *must be avoided* in order to protect equipment, software, data, or service. (ISO)



ALERT! Alerts the reader to an action that *must be performed* in order to prevent equipment damage, software corruption, data loss, or service interruption. (ISO)



FIRE SAFETY! Informs the reader of fire safety information, reminders, precautions, or policies, or of the locations of fire-fighting and fire-safety equipment. (ISO)



SAFETY! Informs the reader of general safety information, reminders, precautions, or policies not related to a particular source of hazard or to fire safety. (ISO, ANSI, OSHA)

IMPORTANT SAFETY INSTRUCTIONS

General Safety



DANGER! YOU MUST FOLLOW APPROVED SAFETY PROCEDURES.

Performing the following procedures may expose you to hazards. These procedures should be performed by qualified technicians familiar with the hazards associated with this type of equipment. These hazards may include shock, energy, and/or burns. To avoid these hazards:

- a) The tasks should be performed in the order indicated.
- b) Remove watches, rings, and other metal objects.
- c) Prior to contacting any uninsulated surface or termination, use a voltmeter to verify that no voltage or the expected voltage is present. Check for voltage with both AC and DC voltmeters prior to making contact.
- d) Wear eye protection.
- e) Use certified and well maintained insulated tools. Use double insulated tools appropriately rated for the work to be performed.

Personal Protective Equipment (PPE)



DANGER! ARC FLASH AND SHOCK HAZARD.

Appropriate PPE and tools required when working on this equipment. An appropriate flash protection boundary analysis should be done determine the “hazard/risk” category, and to select proper PPE.



This product is intended only for installation in a Restricted Access Location.

Only authorized and properly trained personnel should be allowed to install, inspect, operate, or maintain the equipment.

Do not work on LIVE parts. If required to work or operate live parts, obtain appropriate Energized Work Permits as required by the local authority, per NFPA 70E “Standard for Electrical Safety in the Workplace”.

Handling Equipment Containing Static Sensitive Components



ALERT! Installation or removal of equipment containing static sensitive components requires careful handling. Before handling any equipment containing static sensitive components, read and follow the instructions contained on the Static Warning Page.

STATIC WARNING



This equipment contains static sensitive components. The warnings listed below must be observed to prevent damage to these components. Disregarding any of these warnings may result in personal injury or damage to the equipment.

1. Strictly adhere to the procedures provided in this document.
2. Before touching any equipment containing static sensitive components, discharge all static electricity from yourself by wearing a wrist strap grounded through a one megohm resistor. Some wrist straps have a built-in one megohm resistor; no external resistor is necessary. Read and follow wrist strap manufacturer's instructions outlining use of a specific wrist strap.
3. Do not touch traces or components on equipment containing static sensitive components. Handle equipment containing static sensitive components only by the edges that do not have connector pads.
4. After removing equipment containing static sensitive components, place the equipment only on conductive or anti-static material such as conductive foam, conductive plastic, or aluminum foil. Do not use ordinary Styrofoam™ or ordinary plastic.
5. Store and ship equipment containing static sensitive components only in static shielding containers.
6. If necessary to repair equipment containing static sensitive components, wear an appropriately grounded wrist strap, work on a conductive surface, use a grounded soldering iron, and use grounded test equipment.

INTRODUCTION

General

The NetSure™ Model V200D50 DC Power Retrofit is a power solution comprising a Mounting Frame that allows three (3) new-generation NetSure Rectifiers (Model R48-3500e, Spec. No. 1R483500e), to be installed in the NetSure Model 1231V1, Spec. No. 582121100 Power Bay. The Retrofit replaces one V200D50 Power Conversion Unit (PCU), and can operate with or without the original PCUs in the same system.

The V200 Retrofit provides load power, battery float current, and battery recharge current during normal operating conditions. Each rectifier in the Retrofit incorporates a constant power design. This means that, within the normal operating ambient temperature range, the maximum output power available is a constant 10,500W per Retrofit. Within the normal temperature range, the rectifiers operate in one of three modes, depending upon load demands. Transition between modes is completely automatic.

- Constant Voltage Mode: For any initial output voltage setting from 47 to 58 volts, output voltage remains constant regardless of load. This is the normal operating condition, in which loads are being supplied and batteries are float charged. Rectifiers operate in the Constant Voltage Mode unless load increases to the point where the product of load current and output voltage is approximately 10,500W per V200 Retrofit.
- Constant Power Mode: As load increases above approximately 10,500W per V200 Retrofit (non-adjustable), output current continues to increase, but output voltage decreases as required to maintain constant output power. Rectifiers operate in the Constant Power Mode unless load continues to increase to the point where the current limit setting is reached.
- Constant Current Mode: If load increases to the current limit setting, output voltage decreases linearly to maintain output current at the current limit setting.

SPECIFICATIONS

DC Output Ratings

Voltage: Nominal -48 volts DC, Positive Ground.

- a) Without Battery Charge Temperature Compensation: Float voltage is adjustable from 47.00 to 58.00 volts DC. Test/equalize voltage is adjustable from 45.00 to 58.00 volts DC. Adjustment is made via the system MCA. Refer to System Application Guide SAG582121300 for factory settings of Float and Test/Equalize voltages. The output voltage temperature coefficient (1/°C) does not exceed 0.01% per degree centigrade from 0°C to +40°C.
- b) With Battery Charge Digital Temperature Compensation Probe: This operating parameter is identical in systems equipped with the V200D50 Retrofits and systems equipped with the original V200D50 Power Conversion Units (PCUs). Refer to System Application Guide SAG582121100 for a complete description.
- c) With Battery Charge Analog Temperature Compensation Module: This operating parameter is identical in systems equipped with the V200D50 Retrofits and systems equipped with the original V200D50 Power Conversion Units (PCUs). Refer to System Application Guide SAG582121100 for a complete description.

Power and Current, One (1) V200 Retrofit: 10,500W, maximum (180.9A @ 58 VDC to 218.7A @ 48 VDC).

Figure 1 shows the relationship between output voltage and output current at maximum power.

Figure 1: Output Voltage vs. Output Current

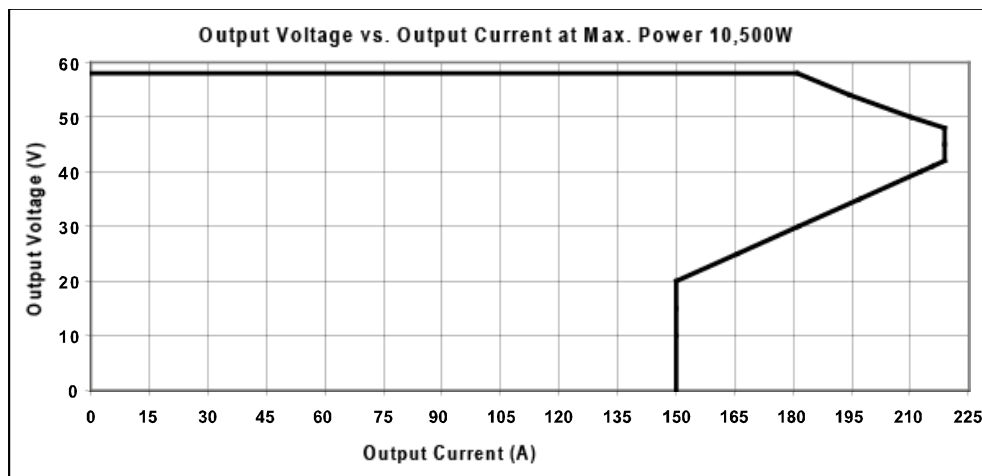

Power Derating Based on Input Voltage: See **Figure 2**.

Figure 2: Output Power vs. Input Voltage

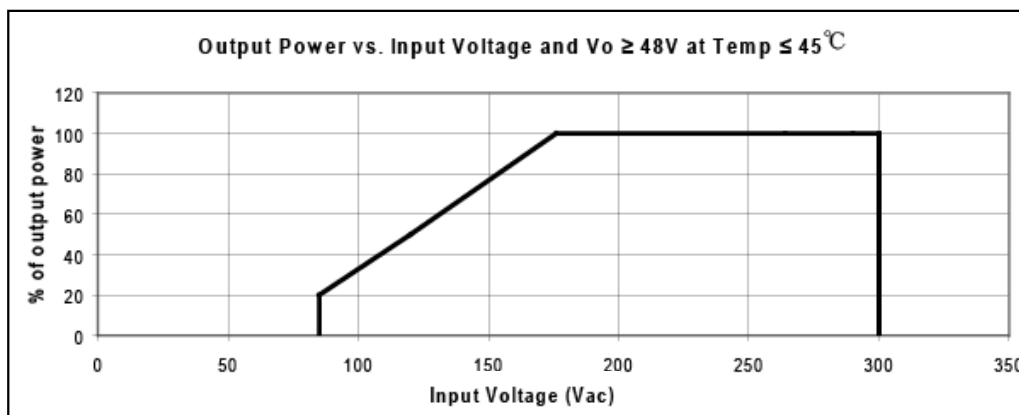

Regulation (Rectifier Default):

- a) Voltage Regulation: $\leq \pm 1\%$
- b) Load Regulation: $\leq \pm 0.5\%$
- c) Line Regulation: $\leq \pm 0.1\%$
- d) Overshoot at Startup: $\leq \pm 1\%$
- e) Dynamic Response (at rated input and output voltage values):

Response time is $\leq 200 \mu\text{s}$, and the overshoot is $\leq 5\%$ for load changes at 50%-25%-50% and 50%-75%-50%.

Overshoot or undershoot is $\leq 5\%$ and within $\pm 1\%$ of the regulation band, ≤ 4 ms at $50 \mu\text{s}$ for load changes at 10%-90% and 90%-10%.

Regulation (via MCA)

- a) Static: The Power System MCA controls the steady state output voltage to within $\pm 0.5\%$ of any voltage setting within the range of 44.0 to 58.0 volts DC for any and all combinations of load from no load to full load, input voltage, and input frequency at a constant ambient temperature. If the MCA's regulation feature is disabled for any reason, steady state regulation is $\pm 1.0\%$ as controlled within the Rectifiers.
- b) Dynamic Response: For any step load change from 10% to 90% or from 90% to 10% of full rated load within 250 microseconds, shall not cause the voltage measured at the output to overshoot or undershoot more than 5% of the regulated output level within 1 millisecond. The output voltage must return and stay within the $\pm 1\%$ regulation band within 4 milliseconds and within the $\pm 0.5\%$ regulation band within 3 seconds.

Any step change of the line voltage within the range of 176 to 264 volts shall not cause the output voltage to deviate outside the $\pm 0.5\%$ regulation band.

Filtering (with or without battery): Typical readings were taken at nominal input voltage, nominal output voltage, 50% load, and 25° C ambient.

- a) Voice Band Noise: Complies with Telcordia GR-947-CORE.
 - 1. Typically 13 dBrn C-message weighting. Does not exceed 32 dBrn C.
 - 2. Typically 0.100 millivolts psophometric. Does not exceed 1 millivolt psophometric.
- b) Wide Band Noise: Complies with Telcordia GR-947-CORE.
 - 1. Typically 150 millivolts peak-to-peak. Does not exceed 200 millivolts peak-to-peak
 - 2. Typically 10 millivolts rms. Does not exceed 30 millivolts rms.

AC Input Ratings

Voltage: Nominal 208/240 volts AC, single phase, 60 Hz, with an operating range of 176 to 264 volts. Acceptable input frequency range is 45 to 65 Hz.

Safe Voltage: The system can tolerate 415 volts AC without damage.

THD (Total Harmonic Distortion): $< 5\%$ THD at 50% - 100% load. The voltage source must have a voltage THD of $< 1.1\%$. The rectifiers comply with EN61000-3-2.

Inrush Current: Peak does not exceed 1.5 times the steady state peak value of the input current at full load, nominal input voltage, and for any duration of AC input interrupts. Under the above conditions, standard AC distribution circuit breakers will not trip.

Typical Input Data: One (1) V200D50 Retrofit, 50 Hz input.

- a) System output is initially adjusted to 54.48 volts DC as measured at the system sense point at 50% of full load and nominal input. “Percent of Full Load” refers to percent of 180 Amperes.

Nominal Input Voltage	Percent of Full Load	Input Current (Amperes)	Input VA	Input Watts	Power Factor	Efficiency %	Heat Dissipation (BTU/Hr)
208	0	0.815	294	61	0.20	--	211
	25	7.410	2669	2607	97.66	94.68	473
	50	14.320	5160	5126	99.36	95.67	757
	75	21.500	7751	7731	99.74	95.57	1169
	100	28.850	10403	10388	99.86	94.73	1869
	110	31.280	11284	11269	99.88	94.30	2192
	120	31.280	11280	11266	99.87	93.80	2383
240	0	0.895	373	61	0.16	--	208
	25	6.504	2709	2630	97.10	95.07	450
	50	12.470	5195	5138.6	98.92	96.07	689
	75	18.500	7706	7670	99.50	95.90	1071
	100	24.890	10364	10338	99.74	95.20	1679
	110	26.950	11220	11195	99.78	94.88	1954
	120	26.940	11217	11190	99.76	94.40	2138

- a) Maximum Input Current: at 100% of full load with output adjusted to 58 volts DC as measured at the Retrofit output terminals, and input voltage as shown.

Nominal Input Voltage	Input Voltage	Input Current (Amperes)
208/240	176	36.47

Typical Input Data: One (1) V200D50 Retrofit, 60 Hz input.

- a) System output is initially adjusted to 54.48 volts DC as measured at the system sense point at 50% of full load and nominal input. “Percent of Full Load” refers to percent of 180 Amperes.

Nominal Input Voltage	Percent of Full Load	Input Current (Amperes)	Input VA	Input Watts	Power Factor	Efficiency %	Heat Dissipation (BTU/Hr)
208	0	0.908	328.9	61.7	0.187	--	211
	25	7.41	2672	2594.5	97.10	94.50	486
	50	14.34	5171	5130	99.20	95.70	752
	75	21.34	7694	7669	99.70	95.60	1161
	100	28.87	10412	10395	99.80	94.60	1910
	110	31.298	11285	11270	99.86	94.40	2139
	120	31.23	11263	11246	99.84	93.88	2348
240	0	1.005	417	61.0	0.146	--	208
	25	6.51	2709	2609.5	96.30	94.80	462
	50	12.53	5218	5143	98.60	96.00	696
	75	18.54	7717	7671	99.39	95.90	1069
	100	24.893	10363	10329	99.67	95.26	1670
	110	26.96	11223	11192	99.72	94.87	1940
	120	26.918	11205	11170	99.69	94.40	2131

- b) Maximum Input Current: at 100% of full load with output adjusted to 58 volts DC as measured at the Retrofit output terminals, and input voltage as shown.

Nominal Input Voltage	Input Voltage	Input Current (Amperes)
208/240	176	36.33

c) Typical Efficiency versus Output Current: See **Figure 3**.

Figure 3: Typical Efficiency

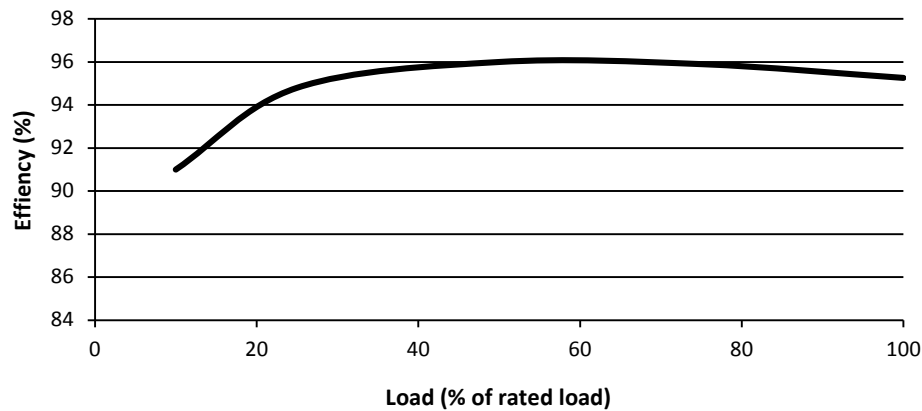

Environmental Ratings

Operating Ambient Temperature Range:

- a) Operational: -40°C to $+75^{\circ}\text{C}$ (-40°F to $+167^{\circ}\text{F}$)
- b) Start: -30°C to $+75^{\circ}\text{C}$ (-22°F to $+167^{\circ}\text{F}$)
- c) Specification Compliant Full Output: -20°C to $+45^{\circ}\text{C}$ (-4°F to $+113^{\circ}\text{F}$)
- d) Reduced Load: $+45^{\circ}\text{C}$ to $+75^{\circ}\text{C}$ ($+113^{\circ}\text{F}$ to $+167^{\circ}\text{F}$). Refer to **Figure 4**.

Storage Ambient Temperature Range: -40°C to $+75^{\circ}\text{C}$ (40°F to $+167^{\circ}\text{F}$).

Humidity: This system is capable of operating in an ambient relative humidity range of 0% to 95%, non-condensing.

Altitude: 2000 m (6560 ft) at full power (power limited for heights above 2000 m).

Ventilation Requirements: When equipped with V200 Retrofits, a VPS Power Bay must be mounted so ventilating openings are not blocked and temperature of the air entering the cabinet does not exceed the Operating Ambient Temperature Range stated previously.

In addition, the distance from the rear of a VPS Power Bay to a wall or other solid structure must not be less than 15 inches. This will assure proper air flow through the V200 Retrofits.

Audible Noise: The audible noise at any point one meter from any vertical surface of a Power Bay, with one V200 Retrofit installed and fans operating, does not exceed the following typical levels. A Sound Level Meter conforming to ANSI S1.4 was used.

- a) Fan at Low Speed: < 59 dBA
- b) Fan at High Speed: < 67 dBA

EMI/RFI Suppression: A V200 Retrofit operating in a NetSure Power Bay conforms to the requirements of FCC rules Part 15, Subpart B, Class A for Radiated and Conducted emissions limits.

Surge Protection: Complies with IEEE C62 41-1991 Class B3, 6kV/3kA (1.2/50 μ s surge voltage and 8/20 μ s surge current).

 **NOTE!** *This level of protection is a widely used standard for telecommunications power equipment. As with all such equipment, it is the end user's responsibility to provide an adequately sized Surge Suppression Device at the commercial power service entrance of the building that reduces all incoming surges to levels below the classes/categories stated for the equipment.*

Compliance Information

- a) Safety: The rectifiers have been recognized to meet the UL/EN/IEC 60950-2000 safety standard and are CE marked.
- b) RoHS: The rectifiers are RoHS compliant, 5/6.

Standard Features

Type of Power Conversion Circuit: High frequency.

Float Charging Output Mode: This operating parameter is identical in systems equipped with the V200D50 Retrofits and systems equipped with the original V200D50 Power Conversion Units (PCUs). Refer to System Application Guide SAG582121100 for a complete description.

Test/Equalize Charging Output Mode: This operating parameter is identical in systems equipped with the V200D50 Retrofits and systems equipped with the original V200D50 Power Conversion Units (PCUs). Refer to System Application Guide SAG582121100 for a complete description.

Output Mode (Float or Test/Equalize) Selection: This operating parameter is identical in systems equipped with the V200D50 Retrofits and systems equipped with the original V200D50 Power Conversion Units (PCUs). Refer to System Application Guide SAG582121100 for a complete description.

Input Protection:

- a) Input Fusing: Input fusing is provided in each rectifier. This fusing is not customer replaceable.
- b) Low AC Input Voltage Protection: If AC input voltage decreases to within the range of approximately 80-176 volts (non-adjustable), the rectifiers continue to operate, but at a reduced maximum output (see **Figure 2**). When AC input voltage increases to approximately 176 volts (non-adjustable), the PCU automatically switches to full output power.

If AC input voltage decreases below approximately 80 volts (non-adjustable), rectifier power conversion circuitry inhibits, disabling system output, and the rectifier protection indicator (yellow) illuminates. When AC input voltage increases to within the range of approximately 95-176 volts (non-adjustable), the system automatically restarts and operates in the reduced power mode.

- c) High AC Input Voltage Protection:
 - 1. Over Voltage Inhibit: If AC input voltage increases to approximately 295 volts, the PCU power conversion circuitry inhibits, disabling system output. When AC input voltage decreases to

approximately 280 volts (non-adjustable), the rectifier automatically restarts, and the protection indicator extinguishes.

2. Over Voltage Isolation: The Rectifier will be disconnected from the AC input when a preset non-adjustable value is reached.

Output Protection:

- a) Current Limiting: The maximum current delivered by the system can be programmed from 10% to 110% of total system capacity. The MCA automatically adjusts the current limit circuit on each V200 Retrofit so that this value is not exceeded. If a V200 Retrofit fails, the MCA automatically resets current limit point of each remaining V200 Retrofit to maintain this value. The MCA also insures that the current limit circuit of each remaining V200 Retrofit is not set above 110% of its capacity. The default current limit setting is the sum of the output ratings of each installed V200 Retrofit. If a V200 Retrofit is added to the system, the system current limit is automatically increased by the rating of the new V200 Retrofit and the new current limit value is displayed.

The current limiting point can be adjusted without removing a V200 Retrofit. One adjustment changes the setting of all V200 Retrofits.

The current limit is factory set at 100% of rated full load, unless otherwise specified.

- b) Thermal Power Limiting: Each rectifier continuously monitors the ambient temperature surrounding the power conversion circuit. If this temperature for any reason (such as a high ambient temperature) increases above approximately +45°C (+113°F), the Rectifier will not shut down. Rather, the rectifier will limit its maximum output power to maintain the temperature of the power conversion circuit within design parameters. Operation between +45°C (+113°F) and +65°C (149°F) will result in the output power being decreased. Full power capability is restored when the temperature decreases to below approximately +45°C (+113°F). **Figure 4** illustrates typical operating parameters.



WARNING! The module is rated for continuous operation at full output power up to +45°C (+113°F). Operation between +45°C (+113°F) and +65°C (149°F) will result in output power decreasing. Operation above +65°C (+149°F) is considered abnormal and should be used on a temporary¹ basis only.

¹ Temporary Operation at Abnormal Temperature: Temporary operation refers to a period of not more than eight consecutive hours per day, and a total of not more than 15 days in a year. (This refers to a total of 120 hours in any given year, but no more than 15 occurrences in that one year period.)

Figure 4: Typical Thermal Power Limit Curve

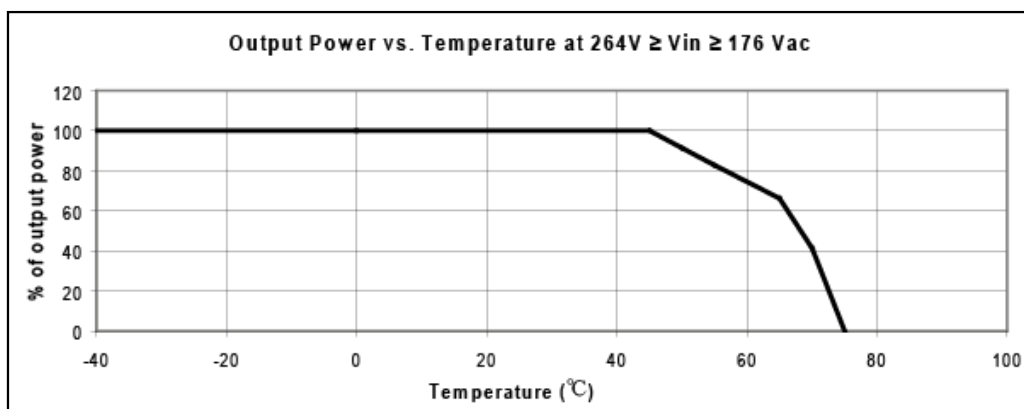

- c) Output Fusing: Output fusing is provided in each Rectifier. If a fuse opens, local and remote Rectifier Fail Alarms activate. This fusing is not customer replaceable.
- d) High Voltage Shutdown (Each Rectifier):
 1. Selective: If rectifier output voltage exceeds an adjustable preset value and is delivering more than 10% of its rated current, the rectifier shuts down.

After approximately 6 seconds, the rectifier automatically restarts. If rectifier output voltage again exceeds the high voltage shutdown value within 5 minutes, the rectifier shuts down and locks out. Manual restart is then required (by turning AC power off or removing the rectifier, then reapplying AC power or reinserting the rectifier). If the rectifier does not experience a high voltage condition within the 5 minute time period, the restart circuit is reset.

Only the rectifier causing the high voltage condition shuts down.

Setpoint is adjustable from 56.00 to 59.00 volts DC. Factory set at 57.50 volts, unless otherwise specified. One adjustment at the MCA changes the setting of all Rectifiers.

2. Backup: If rectifier output voltage exceeds a second (non-adjustable) value, the rectifier shuts down and locks out regardless of load. Manual restart is then required. The backup HVSD setpoint is 59.5V (within the range of 58.5 to 60V).

Output Current Walk-In:

- a) Normal Start:
 - Start up time, defined as beginning at AC switch on and ending when full output power has been reached, consists of two time intervals, the delay period and the output voltage ramp up period.
 - During the delay period the output voltage will be zero.
 - Start up time (AC on, till full power): < 5 seconds.
- b) Current Walk-In (if enabled via Controller):
 - 90% load in > 8S, 100% load in < 124s.
 - According to Telcordia GR-947-CORE, R3-19.

Hot Swappable: Each rectifier is designed to be plug-and-play. The rectifier can be inserted or removed from a live DC power system with no damage. When the rectifier is plugged into the system, the system output voltage will not be affected.



NOTE! *The Retrofit Mounting Frame CANNOT be installed in or removed from the Power Bay unless all Rectifiers are first removed from the Mounting Frame. Doing so will defeat the precharge circuit in the rectifiers and cause arcing and pitting on the DC power connector!*

Cooling: Each rectifier contains one fan for front-to-back forced convection cooling.

Fan Control:

- When input voltage is within normal range, the fan's speed is controlled based on the internal temperature of the rectifier.

- The fan is turned off when input voltage is abnormal such as very low or high input voltage.
- The fan starts at half speed when the rectifier starts up.
- A fan failure is detected and reported to the Controller. In addition, the fault indicator (red) on the Rectifier front panel will flash and the Rectifier will also inhibit its output.
- Full fan speed is customer selectable via the Controller.

Active Load Sharing (Rectifier): Each Rectifier uses advanced digital active load sharing technology that maintains balancing to within $\pm 1.5A$. The difference in the average current between Rectifiers is $< \pm 1.5A$ for loads in the 10 to 100% range.

Load Sharing (via system MCA): The MCA load sharing feature automatically balances the load. If the MCA's load sharing feature is disabled for any reason, pre-programmed slope control in each PCU or Retrofit balances the load. The MCA's load sharing feature is disabled whenever the system is in current limit, the system is delivering more than 97% capacity, or the system is delivering less than 3% capacity.



NOTE! For optimal load sharing between the V200 Retrofits and legacy V200 PCUs, MCA version 4.2.0 or newer is required. With earlier MCA versions, system functionality is maintained; however, load sharing will not be proportional.

Communication Failure: A rectifier's protection indicator (yellow) will begin flashing should it experience a communication failure. The failure information will be reported to the Controller and the Controller will process the failure accordingly. During a communication failure, in order to protect the battery, rectifier output voltage will automatically adjusted to a default value of 53.5 V. The rectifier will revert to normal operation once normal communication is restored.

Imbalance of Rectifier Output Current: When the output current of a rectifier in a DC power system is unbalanced, the rectifier having the unbalanced output current will be identified automatically and its protection indicator (yellow) will illuminate.

The failure information will be reported to the Controller and the Controller will process the failure accordingly.

Paralleling: A Power System equipped with V200 Retrofits may be connected in parallel with any rectifier of the same polarity and adjusted to the same output voltage.

Weight: 58 Lbs. (Mounting Frame with Three Rectifiers)

INSTALLATION

Safety Statement



DANGER! INSTALLERS MUST FOLLOW APPROVED SAFETY PROCEDURES.

Hazardous AC and DC power sources are connected to, and are present within, the Power System. Following this installation procedure will minimize the possibility of personal injury or equipment damage. Refer to the documentation provided with your Power System for any installation or maintenance procedures beyond the scope of this upgrade procedure.

The NetSure™ Model V200D50 DC Power Retrofit is designed to mount in a Model 1231V1, Spec. No. 582121100, Power Bay. Installation in any other Power System should not be attempted.

Installation consists of removing one existing V200D50 Power Conversion Unit (PCU) or blank cover panel from the Power Bay, installing the V200 Retrofit Mounting Frame in the Power Bay, and installing the three furnished NetSure™ R48-3500e Rectifiers in the Mounting Frame.

The V200D50 Retrofit can be installed while the Power System is in service. Before starting, ensure that all AC input and DC output connections to the Power Bay are intact. No changes or adjustments are required for these connections when installing the V200D50 Retrofit. All wiring and grounding should follow the current edition of the National Electrical Code and applicable local codes.

Performing this upgrade procedure may activate external alarms. Do one of the following. If possible, disable these alarms. If these alarms cannot be easily disabled, notify the appropriate personnel to disregard any future alarms associated with this system.

Follow the procedures below to replace one or more existing V200D50 Power Conversion Units (Rectifiers) with the NetSure V200D50 Retrofit.

Remove Style Strips from Power Bay

Procedure

1. Remove the two style strips from the front left and right edges of the VPS Power Bay being upgraded. These conceal the mounting hardware. The style strips are secured at the bottom with a captive fastener, and at the top with a pin that passes through a hole in the style strip. To remove the style strip, loosen the captive fastener at the bottom, and slide the bottom of the style strip out and up.

Remove the Power Conversion Unit (PCU) or Blank Cover Panel

Procedure

1. If the mounting position in the Power Bay has a cover panel rather than a V200 PCU, remove the cover panel by first removing the four screws that secure it. Then skip steps 2 and 3.



NOTE! In the next step, the OUTPUT SWITCH has a mechanical interlock that prevents a PCU from being plugged into or pulled out of a bay with the device in the "on" position.



CAUTION! In a system with NO redundant Rectifier, battery must have sufficient reserve to power the load(s) while the Rectifier is removed.

2. On the PCU to be removed, place the Standby/Operate switch to the "standby" position, then the OUTPUT SWITCH to the 0 "off" position.



DANGER! In the next step, use two people to remove a PCU. A PCU weighs approximately 80 lbs..



NOTE! In the next step, a safety latch is present on each PCU that prevents the PCU from inadvertently being removed completely from the Power Bay.

3. Loosen the captive fasteners on the front of the PCU to be removed. Use the handles provided on the front of the PCU, and pull the PCU out until it is stopped by a safety latch located on the right-hand side panel of the PCU. Refer to **Figure 5** for latch and release location. Depress and hold the latch release, and remove the PCU from the Power Bay. Support the bottom of the PCU as you pull it out.

Figure 5: Right Side View of V200 PCU Showing Location of Safety Latch and Latch Release

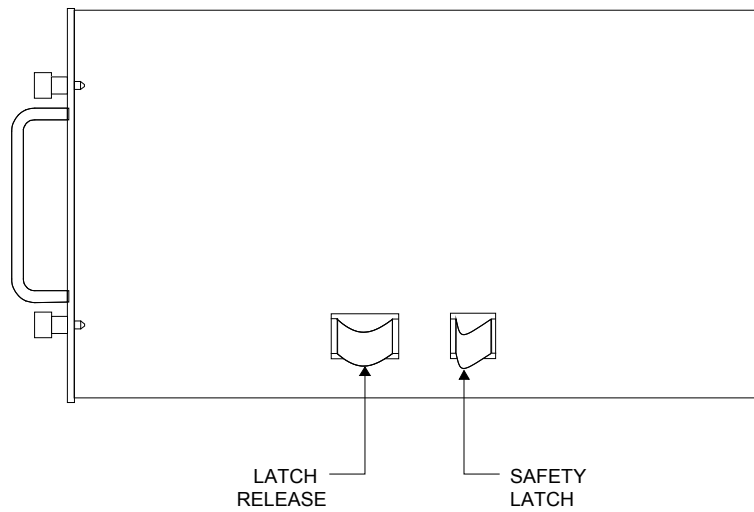

Install the Mounting Frame

The Retrofit Mounting Frame **CANNOT** be installed in the Power Bay unless all Rectifiers are first removed from the Mounting Frame. Doing so will defeat the precharge circuit in the rectifiers and cause arching and pitting on the DC power connector!

Checking the Power Bay's Rectifier AC/Data Connector in Older Style Bays

Identifying Older Style Bays

1. Older style bays have Rectifier AC/Data connectors that do not have springs as shown in **Figure 6**. In bays that have Rectifier AC/Data connectors without springs, perform the following procedure.

Figure 6: Identifying Older Style Bays

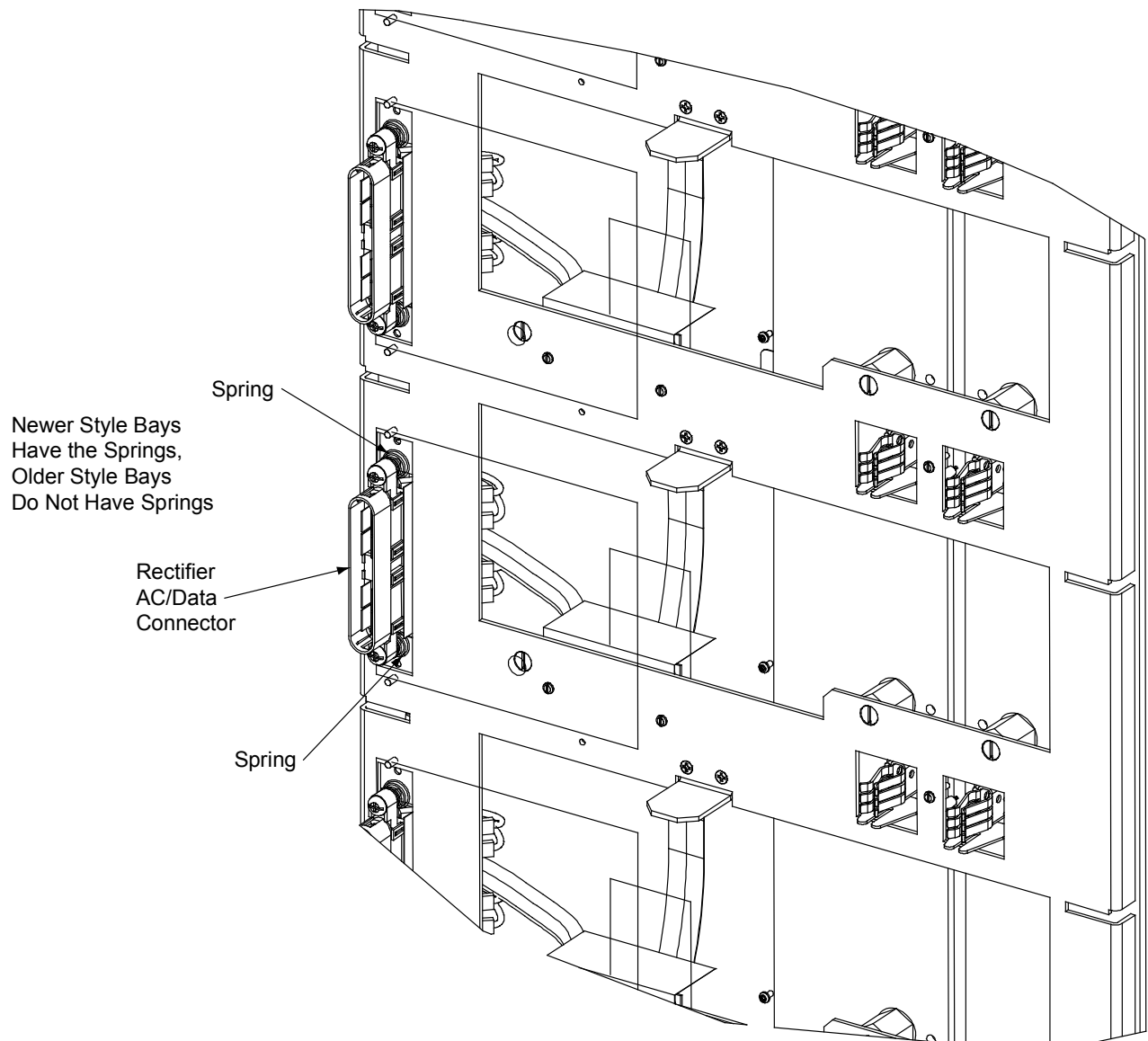

Check Procedure (Older Style Bays Only)

1. With the PCU removed, use a quality wooden carpenter's ruler or other non-conductive rule. Place the measuring device directly against the unpainted bracket holding the AC/Data connector. Take two measurements, one on the bottom of connector directly next to the bolt through the black ac housing, and note the distance to the front outside of the left side panel. Take second measurement on the top of the AC/Data connector. Both must measure $15\text{-}5/16\text{''} + 1/16\text{''}$ or $-1/16\text{''}$ tolerance. See **Figure 7**.

Figure 7: Taking Measurements



2. Pay close attention to the measurements, they must be within $15\text{-}1/4\text{''}$ to $15\text{-}3/8\text{''}$. If a measurement is greater than $15\text{-}3/8\text{''}$ or less than $15\text{-}1/4\text{''}$, adjustment is required (see next procedure).

Adjustment Procedure (Older Style Bays Only, if required)

1. When adjustment of the PCU slot is required, it is recommended to remove the PCU below the slot which requires adjustment. This allows the AC/Data connector to be moved as required to properly set the $15\text{-}5/16\text{''}$ measurements.

 **NOTE!** The MCA will alarm with the removal of any PCU, so be aware Minor and Major alarms could be generated during this process.

2. In the PCU slot to be adjusted, remove the rear sheet metal panel on the rear of bay and locate the two Philips $1/4\text{''}$ self tapping screws at the bottom of panel, which holds the AC connector. Loosen these screws. See **Figure 8**.
3. Directly to the right of the two Philips screws is a single $1/4\text{''}$ inch hex bolt which also must be loosened for lower adjustment. See **Figure 8**.

Figure 8: Locating the Bottom Two 1/4" Self Tapping Screws and 1/4" Hex Bolt

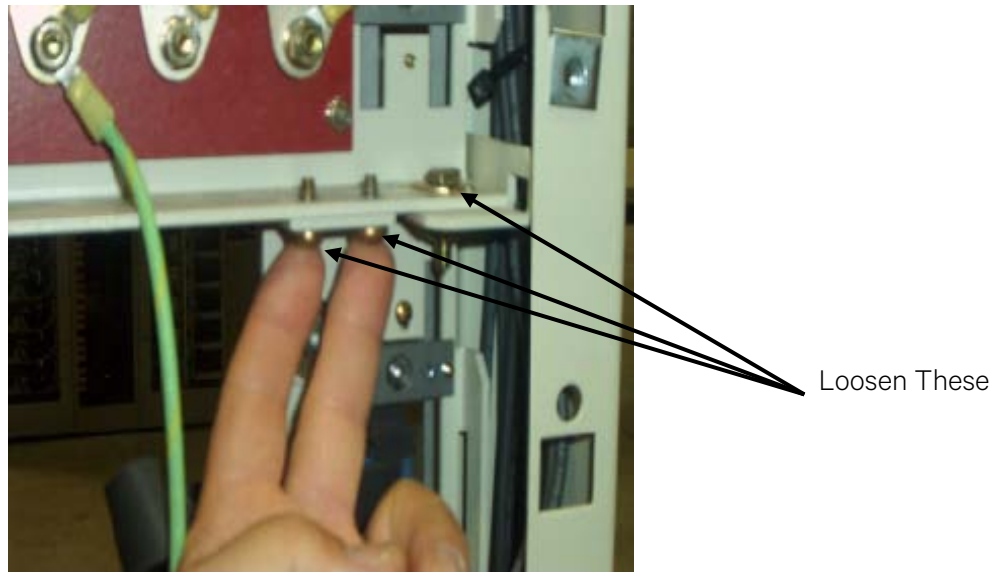

4. Next loosen the two Philips 1/4" self tapping screws at the top of the PCU position to be adjusted. See **Figure 9**.

Figure 9: Locating the Top Two 1/4" Self Tapping Screws

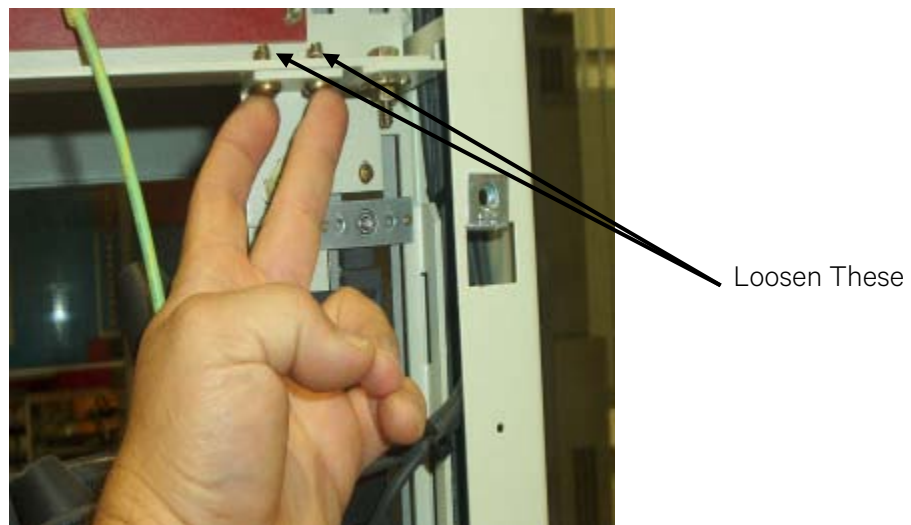

5. With hardware loosened, measure the bottom first for a 15-5/16" and secure the single 1/4" hex bolt first.
6. With bottom secured at 15-5/16", move to the top of the AC connector and measure for 15-5/16", then secure the two Philips screws at the top of the back plane sheetmetal.

NOTE! The process of measurement and securing the hardware may take two people to keep the panel from moving when retorquing the hardware.

7. Torque the top and bottom 1/4" screws (2 each) and bottom 1/4" bolt to 84 in-lbs.
8. Recheck the measurements by performing the previous procedure to verify the proper measurements.

Mounting Procedure

1. Remove the front cover panel from the Mounting Frame by first loosening two captive fasteners. Refer to **Figure 10**.

NOTE! In the next step, the Retrofit Mounting Frame **CANNOT** be installed in the Power Bay unless all Rectifiers are first removed from the Mounting Frame. Doing so will defeat the precharge circuit in the rectifiers and cause arcing and pitting on the DC power connector!

2. Ensure no Rectifiers are present in the Mounting Frame.
3. Slide the empty Mounting Frame into an open mounting position in the Power Bay.
4. Using the supplied hardware, secure the Mounting Frame to the Power Bay.

Figure 10: Removing the Cover Panel from the Mounting Frame

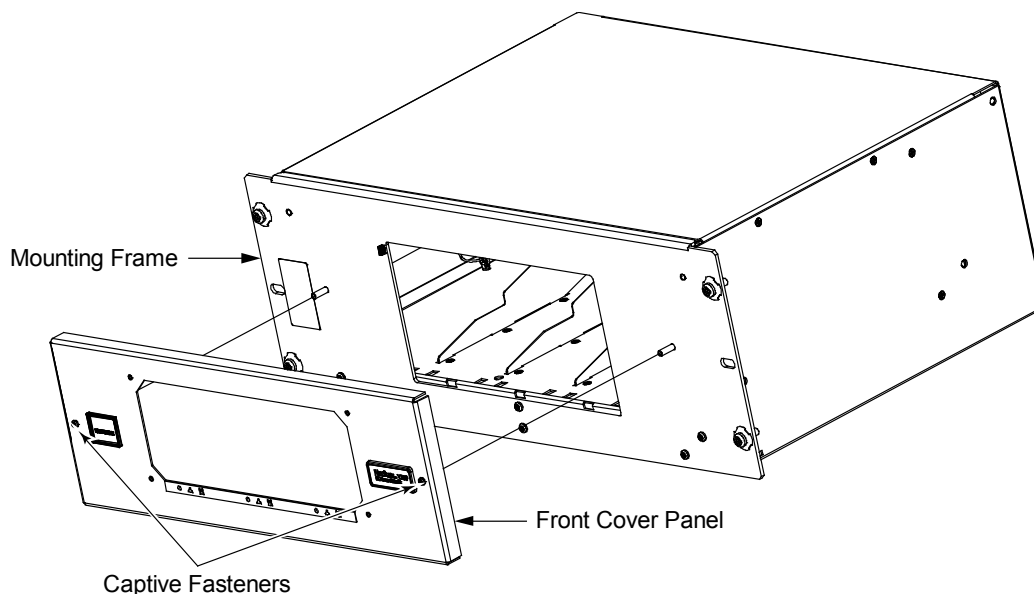

Electrical Connections

All electrical connections to the Mounting Frame are made automatically when the Mounting Frame is installed in the Power Bay. No additional connections are required.

Install the Rectifiers

Procedure

1. Place one Rectifier into an unoccupied mounting position in the Mounting Frame without sliding it in completely.
2. Click the handle on the Rectifier in order to pop it forward out of the front panel (this will also retract the latch mechanism located on the underside of the Rectifier). See **Figure 11**.
3. Gently push the Rectifier completely into the frame.

Figure 11: Rectifier Handle and Safety Latch

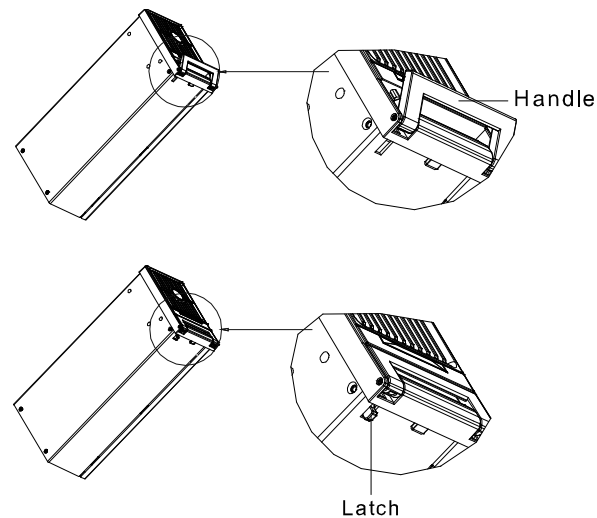

4. Push the handle into the front panel of the Rectifier. This will lock the Rectifier securely to the frame.
5. Repeat Step 1 through 4 for each of the remaining Rectifiers.
6. After the Rectifiers are physically installed in the Mounting Frame, they are ready for operation immediately after power is supplied to them.
7. On the Power System controller (MCA), update the system inventory as necessary. Refer to the Power System documentation for a procedure.



NOTE! The MCA identifies the entire Retrofit Assembly as one PCU.

8. Ensure that there are no local or remote alarms active on the system.
9. Install the front cover on the Mounting Frame. Secure by tightening the two captive fasteners. Refer to **Figure 12**.

Figure 12: Securing Front Cover Panel

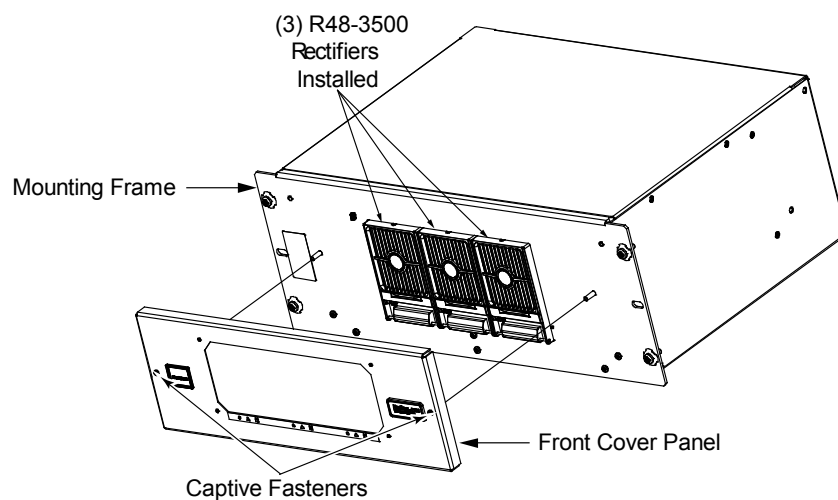

Install Remaining Retrofits in Power Bay

Repeat the installation procedure for each V200 Retrofit remaining to be installed in the Power Bay.

Reinstall Style Strips on Power Bay

After all Retrofits have been installed in the Power Bay, replace the left and right style strips on the front of the bay by sliding the top of the style strip up and over the pin located on top of the bay, then sliding the bottom in and securing with the captive fastener.

Repeat Procedure for Remaining Power Bays

Repeat the entire installation procedure for any remaining Power Bays in the Power System that are to receive the V200 Retrofit.

Final Step

Enable the external alarms, or notify appropriate personnel that this procedure is finished.

OPERATION

Local Indicators

Three indicators are located on the front panel of each rectifier in the V200 Retrofit. The functions of these indicators are as shown in **Table 1**. Refer to **Figure 13** for the location and identification of the local indicators.

NOTE! DC voltage must be present at the V200 Retrofit output terminals, (from battery or an operating rectifier) for local indicators to illuminate.

Figure 13: Status Indicators

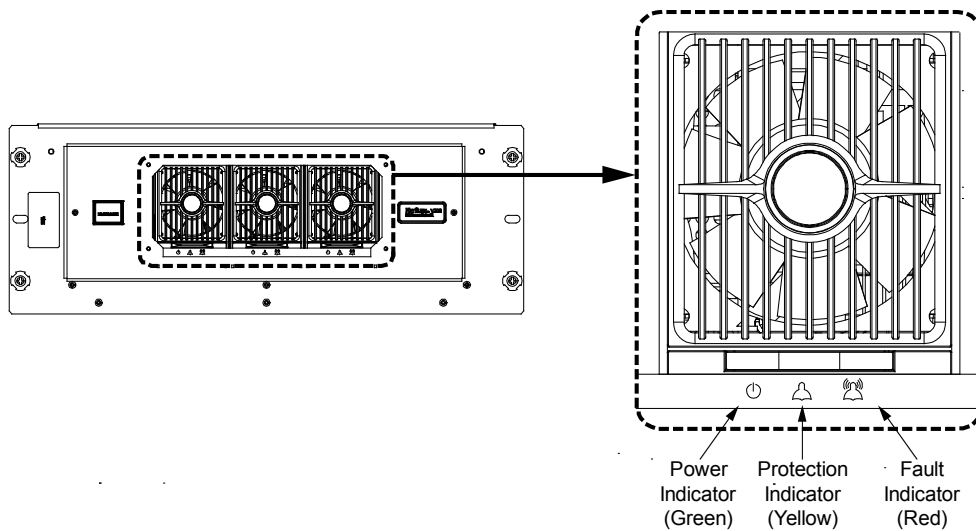

Table 1: Local Indicators

Indicator	Normal State	Fault State	Fault Cause
 Power (Green)	On	Off	No input voltage. Internal input fuse open.
		Flashing	The Rectifier is being identified by the Controller.
 Protection (Yellow)	Off	On	AC input under/over voltage. PFC output under/over voltage. High temperature. Load sharing imbalance.
		Flashing	Rectifier communication failure.
 Alarm (Red)	Off	On	Rectifier output disabled for any reason, including overvoltage shutdown and internal output fuse open. Rectifier addresses contradictory.
		Flashing	Faulty fan (Rectifier shuts down).

Rectifier High Voltage Shutdown and Lockout Restart

Procedure

Turn AC power to the V200 Retrofit OFF or remove the rectifier from the V200 Mounting Frame, wait 30 seconds or more; then turn AC power to the V200 Retrofit ON or re-insert the rectifier. Refer to “Replacing a Rectifier” on page 27 for a rectifier removal procedure.

TROUBLESHOOTING AND REPAIR

Troubleshooting

Rectifier Current Sharing Imbalance

When multiple Rectifiers are operating in parallel and the current sharing imbalance among them is greater than 3%, check to verify the Rectifier is properly seated in the Mounting Frame. (Refer to “Replacing a Rectifier” on page 27 for procedure to remove and reinstall a Rectifier.)

If the current sharing imbalance still persists following the verification suggested above, replace the rectifier exhibiting the current imbalance.



Rectifier Fault Symptoms and Troubleshooting

The Power System controller (MCA) provides the same fault indications for the Retrofit as for the original V200D50 PCUs. Refer to your Power System documentation for details.

 **NOTE!** The system MCA identifies each V200 Retrofit as one PCU. If a PCU fault condition is indicated, observe the local indicators on the Rectifiers in that Retrofit to localize the fault to one Rectifier.

The fault indicators that each Rectifier can display are as follows: Power indicator (green) OFF, Protection indicator (yellow) ON or FLASHING, and Alarm indicator (red) ON or FLASHING. Refer to **Table 2** for a list of possible causes and corrective actions.

Table 2.

Symptom		Possible Cause(s)	Suggested Action(s)
	Power Indicator (Green) Off	No input voltage.	Verify input voltage is available.
		Internal Input fuse open.	Replace the Rectifier.
	Protection Indicator (Yellow) On	AC input voltage outside the normal range.	Correct the AC input voltage to within the acceptable range.
		PFC over-voltage.	Replace the Rectifier.
		Current sharing imbalance.	See “Rectifier Current Sharing Imbalance” on page 26.
		Rectifier over-temperature protection, which could be caused by:	
	1. Fan rotor blocked.	Remove any object that may be blocking the fan rotor.	
	2. Ventilation blocked (inlet or outlet).	Remove any object that may be blocking the inlet or outlet.	
	3. Ambient temperature too high or Rectifier inlet too close to a heat source.	Lower the ambient temperature or relocate the heat source.	
	Rectifier not inserted into the slot completely.	Remove and properly inset the Rectifier.	
	Protection Indicator (Yellow) Flashing	Rectifier communication failure.	Check the communication cables. Remove and properly insert the Rectifier. Replace Interface Circuit Card.
	Alarm Indicator (Red) On	Overvoltage shutdown. Internal output fuse open.	Remove the Rectifier from the Mounting Frame and then reinstall after 30 seconds. If Rectifier fails to start or shuts down again, replace Rectifier.
	Alarm Indicator (Red) Flashing	Fans not operating (Rectifier shuts down)	Replace the fan.

Replacement Procedures

Replacing a Rectifier



DANGER! Use caution when removing a Rectifier that has been operating, as Rectifier surfaces could be very hot.



WARNING! In order to prevent damage to the latching mechanism, do not use excessive force on the Rectifier handle when pushing the Rectifier into the Mounting Frame.



CAUTION! In a system with NO redundant Rectifier, battery must have sufficient reserve to power the load(s) while the Rectifier is removed.

Rectifiers can be inserted or removed with power applied (hot swappable).

Procedure

1. Performing this procedure may activate external alarms. Do one of the following. If possible, disable these alarms. If these alarms cannot be easily disabled, notify the appropriate personnel to disregard any future alarms associated with this system.
2. Remove the front cover panel from the Mounting Frame by first loosening the two captive fasteners. Refer to **Figure 12**.
3. On the Rectifier to be removed, click the handle in order to pop it forwards out of the Rectifier front panel. This will retract the latch mechanism located on the underside of the Rectifier and thus unlock the Rectifier from the shelf. Refer to **Figure 11**.
4. Slide the rectifier out of the Mounting Frame.
5. Place the replacement Rectifier into the mounting slot without sliding it in completely.
6. Click the handle in order to pop it forwards out of the Rectifier front panel (this will also retract the latch mechanism located on the underside of the rectifier).
7. Push the Rectifier completely into the shelf.
8. Push the handle into the front panel of the Rectifier. This will lock the module securely to the shelf.
9. After the Rectifier is physically installed in the Mounting Frame, it is ready for operation immediately after power is supplied to it. Verify that the rectifier is operating normally.
10. On the Power System controller (MCA), update the system inventory as necessary. Refer to the Power System documentation for a procedure.
11. Ensure that there are no local or remote alarms active on the system.
12. Install the front cover on the Mounting Frame. Secure by tightening the two captive fasteners. Refer to **Figure 12**.

Replacing the Rectifier Interface Circuit Card

One Rectifier Interface Circuit Card, Part No. 547568, is located within the V200 Retrofit Mounting Frame. To replace this circuit card perform the following procedure.



CAUTION! When performing any step in this procedure that requires removal or installation of hardware, use caution to ensure no hardware is dropped and left inside the cabinet; otherwise service interruption or equipment damage may occur.



WARNING! Circuit cards used in this equipment contain static-sensitive devices. Read the Static Warning page at the front of this document before performing the following procedure.



NOTE! When performing any step in this procedure that requires removal of existing hardware, retain all hardware for use in subsequent steps.

Procedure

1. Performing this procedure may activate external alarms. Do one of the following. If possible, disable these alarms. If these alarms cannot be easily disabled, notify the appropriate personnel to disregard any future alarms associated with this system.
2. Remove the front cover panel from the Mounting Frame by first loosening the two captive fasteners. Refer to **Figure 12**.



NOTE! The Retrofit Mounting Frame CANNOT be installed in or removed from the Power Bay unless all Rectifiers are first removed from the Mounting Frame. Doing so will defeat the precharge circuit in the rectifiers and cause arcing and pitting on the DC power connector!

3. Remove all three rectifiers from the Mounting Frame. Refer to the previous procedure, “Replacing a Rectifier”, for step-by-step instructions.
4. Remove the two style strips from the front left and right edges of the VPS Power Bay being upgraded. These conceal the mounting hardware. The style strips are secured at the bottom with a captive fastener, and at the top with a pin that passes through a hole in the style strip. To remove the style strip, loosen the captive fastener at the bottom, and slide the bottom of the style strip out and up.
5. Remove the four screws that secure the Mounting Frame to the Power Bay. Remove the Mounting Frame to a static-safe work station.



WARNING! Damage to the circuit card may result if the next step is not followed.

6. Connect an approved grounding strap to your wrist. Attach the other end to a suitable ground.
7. Remove the top/rear cover from the Mounting Frame by removing five screws from the rear and two from each side along the top. Refer to **Figure 14**.
8. Locate the interface circuit card, Part No. 547568. Refer to **Figure 14**.

Figure 14: Replacing the Rectifier Interface Circuit Card

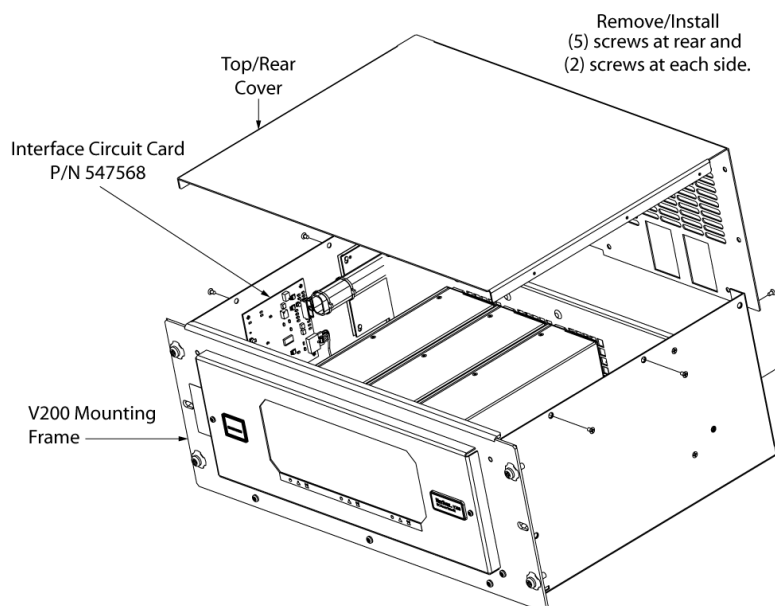

9. Disconnect two (2) cables from the interface circuit card.
10. Remove the one screw that secures the circuit card. Carefully lift the circuit card from its mounting posts, and remove.
11. Place the circuit card over its mounting posts and carefully press down at each post until fully seated. Install and tighten the one mounting screw.
12. Connect the two cables previously disconnected.
13. Install the top/rear cover on the Mounting Frame, and secure with the nine previously removed screws.
14. Remove the grounding wrist strap.



NOTE! In the next step, the Retrofit Mounting Frame CANNOT be installed in the Power Bay unless all Rectifiers are first removed from the Mounting Frame. Doing so will defeat the precharge circuit in the rectifiers and cause arcing and pitting on the DC power connector!

15. Slide the Mounting Frame into its mounting position in the Power Bay. Secure with the four previously removed screws.
16. Install the three Rectifiers into the Mounting Frame. Refer to the previous procedure, “Replacing a Rectifier”, for step-by-step instructions.
17. After the Rectifiers are physically installed in the Mounting Frame, they are ready for operation immediately after power is supplied to them. Verify that the Rectifiers are operating normally.
18. On the Power System controller (MCA), update the system inventory as necessary. Refer to the Power System documentation for a procedure.
19. Ensure that there are no local or remote alarms active on the system.
20. Install the front cover on the Mounting Frame, and secure by tightening the two captive fasteners.

Replacing a Fan in a Rectifier

Each Rectifier in a Mounting Frame uses a fan for cooling. If fan replacement should become necessary, perform the following procedure.

Refer to **Figure 15** as this procedure is performed.



CAUTION! In a system with NO redundant Rectifier, battery must have sufficient reserve to power the load(s) while the Rectifier is removed for fan replacement.



WARNING! Circuit cards used in this equipment contain static-sensitive devices. Read the Static Warning page at the front of this document before performing the following procedure.



NOTE! When performing any step in this procedure that requires removal of existing hardware, retain all hardware for use in subsequent steps.

Procedure

1. Performing this procedure may activate external alarms. Do one of the following. If possible, disable these alarms. If these alarms cannot be easily disabled, notify the appropriate personnel to disregard any future alarms associated with this system.

2. Remove the front cover panel from the Mounting Frame by first loosening the two captive fasteners. Refer to **Figure 12**.
3. Remove the Rectifier from the Mounting Frame. Refer to a previous procedure, “Replacing a Rectifier”, for step-by-step instructions.
4. Place the Rectifier on a static-safe work surface. Connect an approved grounding strap to your wrist for the remainder of this procedure.
5. Loosen the three (3) screws on the rectifier front cover and remove the cover.
6. Unplug the power cable of the fan and remove the fan.
7. Place the new fan in the space vacated by the old fan.
8. Plug the fan power cable back into the corresponding socket. Push back the fan (the side with the tag facing inward). Position the rectifier front cover back into place and secure with the three previously removed screws.
9. Reinstall the Rectifier into the Mounting Frame. Refer to a previous procedure, “Replacing a Rectifier”, for step-by-step instructions.
10. When the fans start, check to ensure that each is providing front-to-back airflow. If air direction is wrong, immediately remove the Rectifier from the Mounting Frame. Repeat previous steps to check fan orientation, and correct as necessary. Reinstall the Rectifier and again check for proper airflow.
11. Enable the external alarms, or notify appropriate personnel that this procedure is finished.
12. Ensure that there are no local or remote alarms active on the system.
13. Install the front cover on the Mounting Frame, and secure by tightening the two captive fasteners.

Figure 15: Rectifier Fan Replacement

