

SYSTEM OVERVIEW

Description:	Front access Vertiv™ NetSure™ -48 VDC Battery Rack System consisting of a 27.5" wide x 22.7" deep x 84" tall free-standing box framework, five (5) battery trays, and battery termination busbar assemblies. The battery trays accommodate a variety of 12-volt front terminal valve regulated lead acid (VRLA) batteries. Each tray mounts one -48V string of four (4) batteries. Includes factory routed and lugged cabling from each battery tray to the battery termination busbar assemblies. Also equipped with left side mounted battery disconnect circuit breakers. Factory circuit breaker alarm wiring is provided to an alarm card. The alarm card provides external relay contacts and resistive battery for connection to customer external alarm circuits.
Application:	For use with -48 VDC NetSure™ Power Systems and other -48 VDC Power Systems
Family:	NetSure™
Spec. Nos.:	588820400100, 588820400150, 588820400200
Model:	48BA800-23
General Specifications: (see detailed specifications on page 12)	
Output Voltage:	-48 VDC
Output Capacity:	800 A, maximum
System Agency Approval:	UL 1801 Listed ("c UL"), NEBS, Seismic Zone 4
Framework Type:	Box Framework
Mounting Width:	27.5"
Mounting Depth:	22.7"
Height	84"
Access:	Front for Installation, Operation, and Maintenance
Color:	Textured Dark Gray
Environment:	0 °C to +40 °C (32 °F to +104 °F)

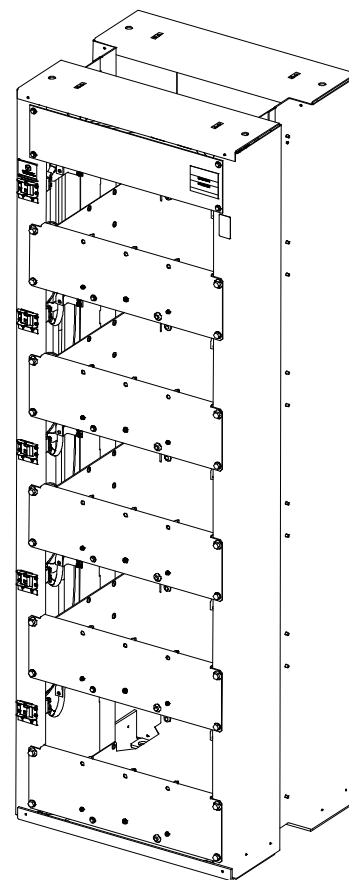

Vertiv™ NetSure™ -48 VDC Battery Rack System

System Application Guide

TABLE OF CONTENTS

SYSTEM OVERVIEW.....	1
MAIN COMPONENTS ILLUSTRATIONS	3
DESCRIPTIONS.....	4
Battery Rack Systems.....	4
588820400100: Battery Rack System with 100 A Battery Disconnect Circuit Breakers	4
588820400150: Battery Rack System with 150 A Battery Disconnect Circuit Breakers.....	4
588820400200: Battery Rack System with 200 A Battery Disconnect Circuit Breakers.....	5
ACCESSORY DESCRIPTIONS.....	6
Battery Rack Isolation Kit	6
Batteries	7
Crimp Lugs.....	8
Battery Spacer Shim, Part No. 564917	9
Battery Retainer Kit, Part No. 10010061	9
RECOMMENDED WIRE SIZES, BRANCH CIRCUIT PROTECTION, AND CRIMP LUGS.....	10
Rack Frame Grounding Requirements.....	10
Recommended Battery Rack Output Lead Wire Sizes	10
800 Ampere Cable-Connected Stand-Alone Battery Rack	10
600 Ampere Cable-Connected Stand-Alone Battery Rack.....	11
400 Ampere Cable-Connected Stand-Alone Battery Rack.....	11
SPECIFICATIONS	12
1. System	12
1.1 Output Ratings.....	12
1.2 Environmental Ratings	12
1.3 Compliance Information.....	12
MECHANICAL SPECIFICATIONS.....	13
Overall Dimensions.....	13
Dimensions with Battery Retainer Kit (P/N 10010061).....	14
Floor Mounting Dimensions	15
Battery Rack Output Lug Landing Dimensions.....	16
Circuit Breaker Alarms	17
BATTERY MANUFACTURER INFORMATION.....	18
RELATED DOCUMENTATION.....	18

MAIN COMPONENTS ILLUSTRATIONS

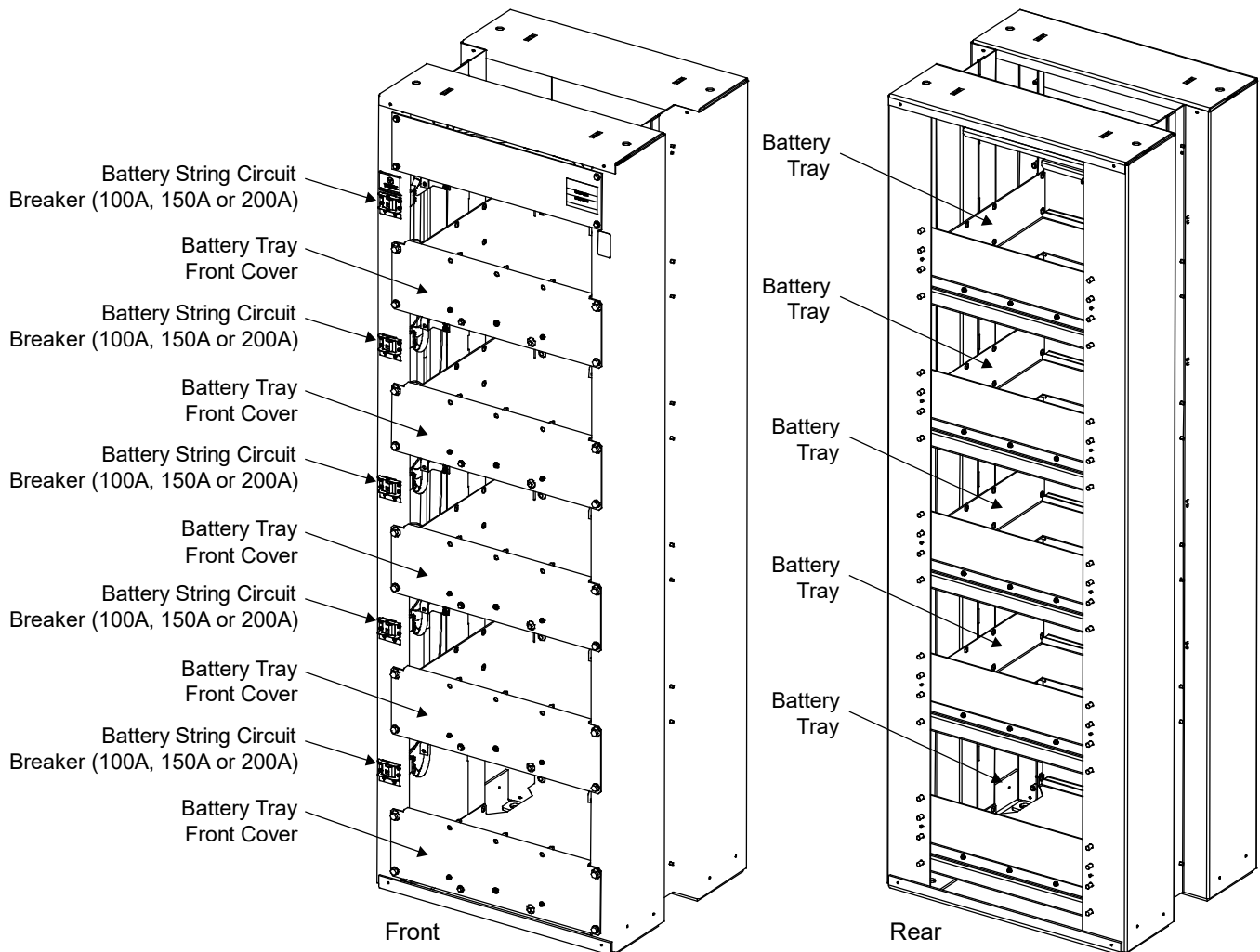
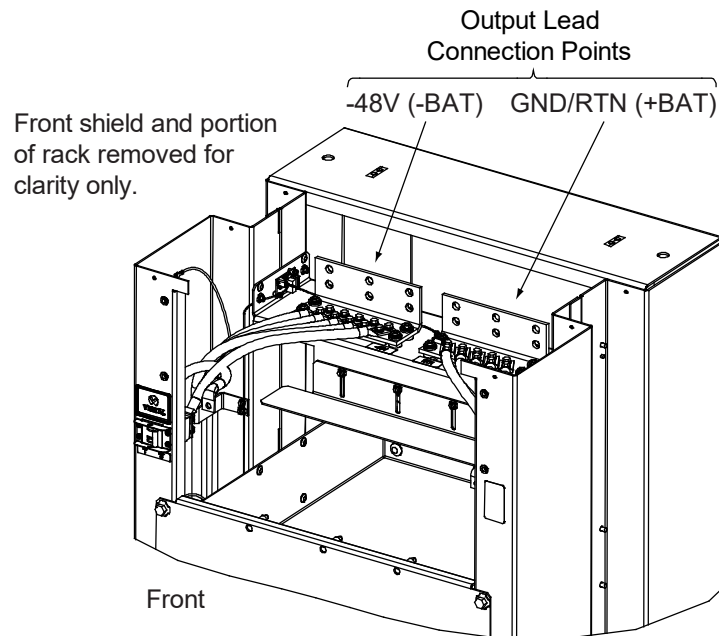

DESCRIPTIONS

Battery Rack Systems

588820400100: Battery Rack System with 100 A Battery Disconnect Circuit Breakers

Features

- ◆ Provides one assembled “stand-alone” battery rack. Includes (1) 27.5” wide x 22.6” deep x 84” tall box framework, (5) battery trays, battery termination busbar assemblies, (1) instruction manual, and packaging. Also includes factory routed and lugged cabling from each battery tray to the battery termination busbar assemblies. Also equipped with (5) left side mounted 100 A battery disconnect circuit breakers. Factory circuit breaker alarm wiring is provided to an alarm card. The alarm card provides external relay contacts and resistive battery for connection to customer external alarm circuits.
- ◆ Eight (8) P/N 564901 Floor Anchor Reinforcing Plates are furnished with each battery rack. (2.0" x 2.0" x 0.25" thick, with a 1" diameter hole).

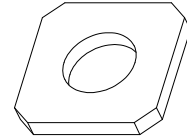

Restrictions

For use with a power system mounted in separate bay.

Designed to accommodate the batteries listed under “Batteries” on page 7.

Battery circuit breakers are E/M trip. E/M (Electrical/Mechanical) trip circuit breaker (black handle) provides an alarm during and electrical or manual trip condition.

The maximum total current is 400 A based on 80% of the total disconnect breaker rating.

Ordering Notes

- 1) Order one (1) 588820400100 per system for a system with 100 A battery circuit breakers.
- 2) Order Battery Rack Isolation Kit, P/N 10019129, as required. See “Battery Rack Isolation Kit” on page 6.
- 3) Order batteries separately. See “Batteries” on page 7.
- 4) Order Battery Space Shim, P/N 564917, for use with certain batteries. See Table 1.
- 5) Order Battery Retainer Kit, P/N 10010061, for use with certain batteries. See Table 1.

588820400150: Battery Rack System with 150 A Battery Disconnect Circuit Breakers

Features

- ◆ Provides one assembled “stand-alone” battery rack. Includes (1) 27.5” wide x 22.6” deep x 84” tall box framework, (5) battery trays, battery termination busbar assemblies, (1) instruction manual, and packaging. Also includes factory routed and lugged cabling from each battery tray to the battery termination busbar assemblies. Also equipped with (5) left side mounted 150 A battery disconnect circuit breakers. Factory circuit breaker alarm wiring is provided to an alarm card. The alarm card provides external relay contacts and resistive battery for connection to customer external alarm circuits.
- ◆ Eight (8) P/N 564901 Floor Anchor Reinforcing Plates are furnished with each battery rack. (2.0" x 2.0" x 0.25" thick, with a 1" diameter hole).

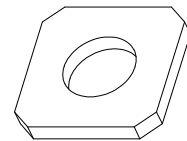

Restrictions

For use with a power system mounted in separate bay.

Designed to accommodate the batteries listed under “Batteries” on page 7.

Battery circuit breakers are E/M trip. E/M (Electrical/Mechanical) trip circuit breaker (black handle) provides an alarm during and electrical or manual trip condition.

The maximum total current is 600 A based on 80% of the total disconnect breaker rating.

Ordering Notes

- 1) Order one (1) 588820400150 per system for a system with 150 A battery circuit breakers.
- 2) Order Battery Rack Isolation Kit, P/N 10019129, as required. See “Battery Rack Isolation Kit” on page 6.
- 3) Order batteries separately. See “Batteries” on page 7.
- 4) Order Battery Space Shim, P/N 564917, for use with certain batteries. See Table 1.
- 5) Order Battery Retainer Kit, P/N 10010061, for use with certain batteries. See Table 1.

Vertiv™ NetSure™ -48 VDC Battery Rack System

System Application Guide

588820400200: Battery Rack System with 200 A Battery Disconnect Circuit Breakers

Features

- ◆ Provides one assembled “stand-alone” 800 A battery rack. Includes (1) 27.5” wide x 22.6” deep x 84” tall box framework, (5) battery trays, battery termination busbar assemblies, (1) instruction manual, and packaging. Also includes factory routed and lugged cabling from each battery tray to the battery termination busbar assemblies. Also equipped with (5) left side mounted 200 A battery disconnect circuit breakers. Factory circuit breaker alarm wiring is provided to an alarm card. The alarm card provides external relay contacts and resistive battery for connection to customer external alarm circuits.
- ◆ Eight (8) P/N 564901 Floor Anchor Reinforcing Plates are furnished with each battery rack. (2.0" x 2.0" x 0.25" thick, with a 1" diameter hole).

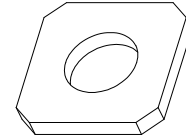

Restrictions

For use with a power system mounted in separate bay.

Designed to accommodate the batteries listed under “Batteries” on page 7.

Battery circuit breakers are E/M trip. E/M (Electrical/Mechanical) trip circuit breaker (black handle) provides an alarm during and electrical or manual trip condition.

Ordering Notes

- 1) Order one (1) 588820400200 per system for a system with 200 A battery circuit breakers.
- 2) Order Battery Rack Isolation Kit, P/N 10019129, as required. See “Battery Rack Isolation Kit” on page 6.
- 3) Order batteries separately. See “Batteries” on page 7.
- 4) Order Battery Space Shim, P/N 564917, for use with certain batteries. See Table 1.
- 5) Order Battery Retainer Kit, P/N 10010061, for use with certain batteries. See Table 1.

ACCESSORY DESCRIPTIONS

Battery Rack Isolation Kit

Features

- ◆ Provides electrical isolation of the battery rack from the concrete floor. Includes an insulating pad, four (4) insulating bushings, and four (4) flat washers to be used with the anchors used to mount the battery rack to the floor.

Ordering Notes

- 1) Order P/N 10019129 for a Battery Rack Isolation Kit to be used with 588820400100, 588820400150, and 588820400200.

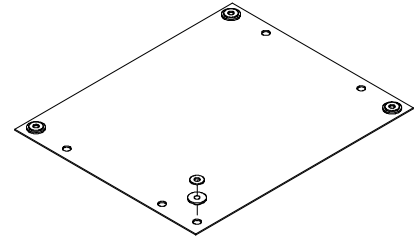

Vertiv™ NetSure™ -48 VDC Battery Rack System

System Application Guide

Batteries

Ordering Notes

- 1) Order four (4) batteries per battery string from Table 1 as required.
- 2) For batteries that require an optional “Battery Spacer Shim”, order one shim per battery tray. See “Battery Spacer Shim, Part No. 564917” on page 9.
- 3) For batteries that require a “Battery Retainer Kit”, order one (1) kit per battery tray. See “Battery Retainer Kit, Part No. 10010061” on page 9.

Manufacturer*	Manufacturer P/N	Vertiv P/N (12 V Module)	Capacity (A-Hr)	Dimension L x W x H (Inches) (per 12 V Module)	Weight (lb) (per 12V battery)	Requires Battery Spacer Shim, Part No. 564917	Requires Battery Retainer Kit, Part No. 10010061
C&D	TEL12-160F	140456	151	20.16 x 4.86 x 11.14	115	Recommended 3 Qty of Shims	--
C&D	TEL12-180F	--	174	20.16 x 4.86 x 12.6	131	Recommended 3 Qty of Shims	--
C&D	TEL12-210F	554579	202	20.1 x 4.8 x 12.6	132	Recommended 3 Qty of Shims	--
Deka	12AVR-150ET	122018	150	20.86 x 4.86 x 11.63	115	Recommended 1 Qty of Shims	--
Deka	12AVR-170ET	541381	170	20.86 x 4.86 x 12.6	120	Recommended 1 Qty of Shims	--
Deka	12AVR-200ET	--	200	24.30 x 4.97 x 12.74	151	--	Yes
Deka	HT170ET	--	164	20.86 x 4.86 x 12.58	151	Recommended 1 Qty of Shims	--
Deka	HT200ET	--	190	24.15 x 4.97 x 12.74	151	--	Yes
Energysys	12V155FS	122010	155	20.75 x 4.92 x 11.14	106.9	Recommended 1 Qty of Shims	--
Energysys	12V170FS	--	170	20.7 x 4.89 x 11.14	112	Recommended 1 Qty of Shims	--
Energysys	SBS 170F	--	170	20.74 x 4.89 x 11.14	116	Recommended 2 Qty of Shims	--
Energysys	SBS 190F	--	190	20.74 x 4.89 x 12.46	132	Recommended 1 Qty of Shims	--
FIAMM	12FAT100	--	100	21.97 x 4.96 x 9.06	95	No info yet	--
FIAMM	12FAT155	--	155	21.97 x 4.96 x 12.64	129		--
FIAMM	12FAT180	--	100	21.97 x 4.96 x 12.64	134		--
FIAMM	12FAT181	--	180	21.97 x 4.96 x 12.64	130		--
Northstar	NSB155FT RED	--	155	22.00 x 4.90 x 11.00	101		--
Northstar	NSB170FT RED	126111	170	22.00 x 4.90 x 12.60	116		--
Northstar	NSB190FT RED	--	190	22.00 x 4.90 x 12.60	123		--
Northstar	NSB155FT HT	--	154	22.00 x 4.90 x 11.00	117		--
Northstar	NSB170FT HT	--	174	22.00 x 4.90 x 12.60	121		--
Northstar	NSB190FT HT	--	190	22.00 x 4.90 x 12.60	132		--
GS Yuasa	PYL12V160FT	--	160	21.90 x 4.90 x 11.00	116.20	Recommended 1 Qty of Shims	--
GS Yuasa	PYL12V185FT	--	185	21.90 x 4.90 x 11.00	133.80	Recommended 1 Qty of Shims	--

* See “Battery Manufacturer Information” on page 18.

Table 1
Batteries

Vertiv™ NetSure™ -48 VDC Battery Rack System

System Application Guide

Crimp Lugs

Battery Rack Equipment Grounding (Frame Ground) Lug Landing Points

A customer's grounding network lead can be attached to the top of each rack. Provision is made for installing a lead with a two-hole lug that has 1/4" bolt clearance holes on 5/8" centers. Refer to Table 2 for lug selection. Refer to "Rack Frame Grounding Requirements" on page 10 for rack grounding information.

Lead Size	Part Number
14 AWG to 10 AWG	245342300
8 AWG	245390200
6 AWG	245346700
4 AWG	245346800
2 AWG	245346900

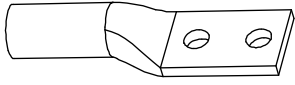

Lugs should be crimped per lug manufacturer's specifications.

Table 2
Crimp Lug (Two-Hole, 1/4" Bolt Clearance Hole, 5/8" Centers)

Battery Rack Output Busbar Lug Landing Points

The battery rack is equipped with top-mounted battery busbar termination assemblies which provide three (3) negative battery rack output (-48V) and three (3) positive battery rack output (GND/RTN) lug landing points. These lug landing points provide clearance holes for 3/8" bolts for installation of customer-provided two-hole lugs that have 1" centers and 3/8" bolt clearance holes. Customer must provide lug mounting bolts and additional hardware. Refer to "Battery Rack Output Lug Landing Dimensions" on page 16.

The battery busbar termination assemblies are designed to accommodate the lugs listed in Table 3. Use Table 4 to select recommended battery rack output lead sizes and lugs for various loop lengths for the maximum battery rack output capacity rating (800 A). When making connections observe correct polarity.

Battery Rack Output Lug Part Numbers

Lead Size	Part Number
6 AWG	245349900
4 AWG	245350000
2 AWG	245348200
1/0 AWG	245347100
2/0 AWG	245347200
3/0 AWG	245347300
4/0 AWG	245347400
250 kcmil	245347500
300 kcmil	245347600
350 kcmil	245347700
400 kcmil	245347800
500 kcmil	245347900
600 kcmil	245348000
750 kcmil	245348100

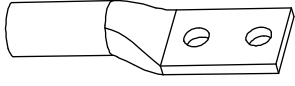

Lugs should be crimped per lug manufacturer's specifications.

Table 3
Crimp Lug (Two-Hole, 3/8" Bolt Clearance Hole, 1" Centers)

Vertiv™ NetSure™ -48 VDC Battery Rack System

System Application Guide

Battery Spacer Shim, Part No. 564917

Features

- ◆ To ensure spacing between batteries, spacers are provided on the rear and front cover of each battery tray. For certain batteries of shorter length, a shim is required between the front retaining bracket and the spacers. Kit includes ten (10) shims and the necessary hardware.

Restrictions

Shims are to be installed by customer.

Ordering Notes

- 1) Order one (1) kit of shims and hardware per battery rack, if required. See Table 1 for requirement.

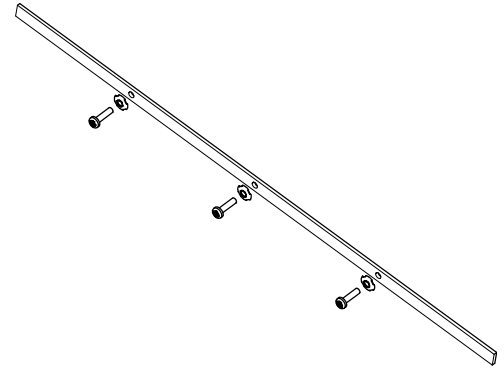

Battery Retainer Kit, Part No. 10010061

Features

- ◆ This kit is used to accommodate batteries with a deeper profile (longer length). Refer to Table 1 for batteries requiring this kit. This kit includes a front retaining bracket, a top retaining bracket, and installation hardware.
- ◆ This kit can be factory or field installed.

Ordering Notes

- 1) Refer to Table 1 for batteries requiring this kit. Order one (1) battery retainer kit P/N 10010061 for each battery tray using batteries requiring this kit.

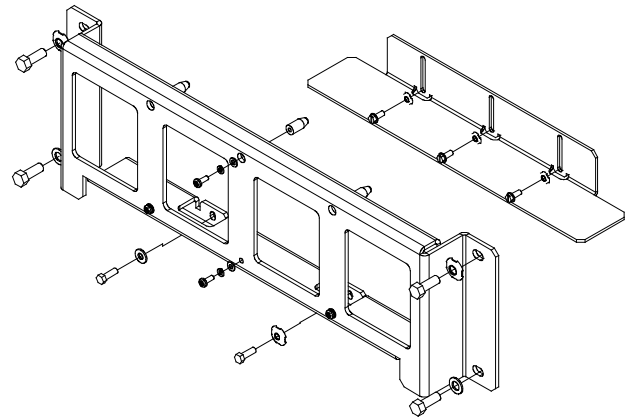

Battery Retainer Kit

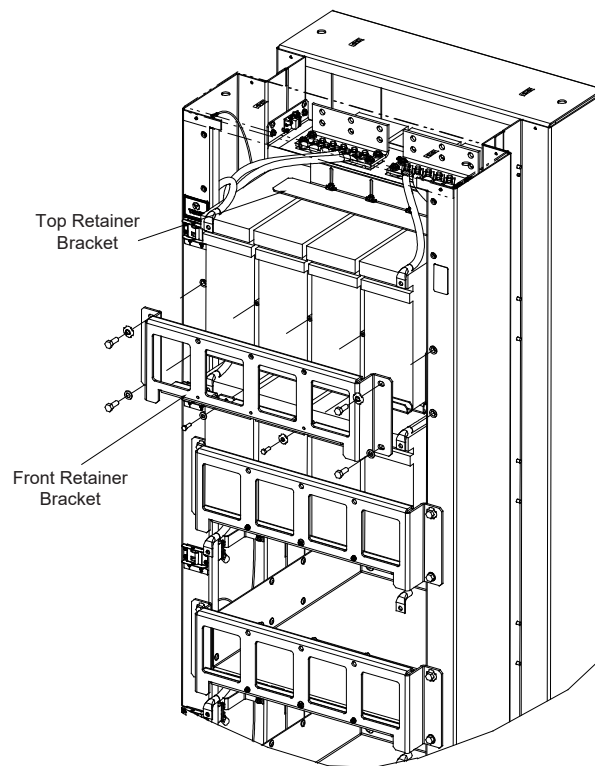

Mounting View of Battery Retainer Kit

RECOMMENDED WIRE SIZES, BRANCH CIRCUIT PROTECTION, AND CRIMP LUGS

Rack Frame Grounding Requirements

For rack grounding requirements, refer to the current edition of the American National Standards Institute (ANSI) approved National Fire Protection Association's (NFPA) National Electrical Code (NEC), applicable local codes, and your specific site requirements.

A customer's grounding network lead can be attached to the top of each rack. Provision is made for installing a lead with a two-hole lug that has 1/4" bolt clearance holes on 5/8" centers. Refer to "Battery Rack Equipment Grounding (Frame Ground) Lug Landing Points" on page 8 for lug selection.

Recommended Battery Rack Output Lead Wire Sizes

800 Ampere Cable-Connected Stand-Alone Battery Rack

Lug and Wire Size Selection for 800 Ampere Cable-Connected Stand-Alone Battery Rack				
Ambient Operating Temperature ⁽¹⁾	Loop Length (Ft) 1.0 Voltage Drop ⁽²⁾	Loop Length (Ft) 0.25 Voltage Drop ⁽²⁾	Recm 90°C Wire Size (AWG) ⁽¹⁾	Recommended Crimp Lug ⁽³⁾
+40°C (+104°C)	71.4	17.8	(6) 1/0 AWG	(6) 245347100
	75.6	18.9	(4) 3/0 AWG	(4) 245347300
	101.4	25.3	(3) 300 kcmil	(3) 245347600
	135.1	33.8	(2) 600 kcmil	(2) 245348000
	168.9	42.2	(2) 750 kcmil	(2) 245348100
	253.4	63.3	(3) 750 kcmil	(3) 245348100
	337.8	84.5	(4) 750 kcmil	(4) 245348100
	422.3	105.6	(5) 750 kcmil	(5) 245348100
	506.8	126.7	(6) 750 kcmil	(6) 245348100

¹ Wire sizes based on recommendations of the American National Standards Institute (ANSI) approved National Fire Protection Association's (NFPA) National Electrical Code (NEC), Table 310.15 (B) (16) for copper wire at 90 °C conductor temperature. For operation in countries where the NEC is not recognized, follow applicable codes.

² Recommended wire sizes are sufficient to restrict voltage drop to the voltage shown in the column heading, or less, at rated full load output current of the system for the loop lengths shown in this column. Loop length is the sum of the lengths of the positive and negative leads.

³ Two-hole lug, 3/8 bolt clearance hole, 1" centers. Lugs should be crimped per lug manufacturer's specifications.

Table 4

Vertiv™ NetSure™ -48 VDC Battery Rack System

System Application Guide

600 Ampere Cable-Connected Stand-Alone Battery Rack

Lug and Wire Size Selection for 600 Ampere Cable-Connected Stand-Alone Battery Rack				
Ambient Operating Temperature ⁽¹⁾	Loop Length (Ft) 1.0 Voltage Drop ⁽²⁾	Loop Length (Ft) 0.25 Voltage Drop ⁽²⁾	Recm 90°C Wire Size (AWG) ⁽¹⁾	Recommended Crimp Lug ⁽³⁾
+40°C (+104°C)	49.8	12.5	(5) 2 AWG	(5) 245348200
	63.4	15.9	(4) 1/0 AWG	(4) 245347100
	75.6	18.9	(3) 3/0 AWG	(3) 245347300
	105.1	26.3	(2) 350 kcmil	(2) 245347700
	120.1	30.0	(2) 400 kcmil	(2) 245347800
	150.2	37.5	(2) 500 kcmil	(2) 245347900
	180.2	45.0	(2) 600 kcmil	(2) 245348000
	225.2	56.3	(2) 750 kcmil	(2) 245348100
	337.8	84.5	(3) 750 kcmil	(3) 245348100

¹ Wire sizes based on recommendations of the American National Standards Institute (ANSI) approved National Fire Protection Association's (NFPA) National Electrical Code (NEC), Table 310.15 (B) (16) for copper wire at 90 °C conductor temperature. For operation in countries where the NEC is not recognized, follow applicable codes.

² Recommended wire sizes are sufficient to restrict voltage drop to the voltage shown in the column heading, or less, at rated full load output current of the system for the loop lengths shown in this column. Loop length is the sum of the lengths of the positive and negative leads.

³ Two-hole lug, 3/8 bolt clearance hole, 1" centers. Lugs should be crimped per lug manufacturer's specifications.

Table 5

400 Ampere Cable-Connected Stand-Alone Battery Rack

Lug and Wire Size Selection for 400 Ampere Cable-Connected Stand-Alone Battery Rack				
Ambient Operating Temperature ⁽¹⁾	Loop Length (Ft) 1.0 Voltage Drop ⁽²⁾	Loop Length (Ft) 0.25 Voltage Drop ⁽²⁾	Recm 90°C Wire Size (AWG) ⁽¹⁾	Recommended Crimp Lug ⁽³⁾
+40°C (+104°C)	35.5	8.9	(6) 6 AWG	(6) 245349900
	47.0	11.8	(5) 4 AWG	(4) 245350000
	59.8	14.9	(4) 2 AWG	(4) 245348200
	71.4	17.8	(3) 1/0 AWG	(3) 245347100
	75.6	18.9	(2) 3/0 AWG	(2) 245347300
	135.1	33.8	(1) 600 kcmil	(1) 245348000
	168.9	42.2	(1) 750 kcmil	(1) 245348100
	337.8	84.5	(2) 750 kcmil	(q) 245348100
	506.8	126.7	(3) 750 kcmil	(1) 245348100

¹ Wire sizes based on recommendations of the American National Standards Institute (ANSI) approved National Fire Protection Association's (NFPA) National Electrical Code (NEC), Table 310.15 (B) (16) for copper wire at 90 °C conductor temperature. For operation in countries where the NEC is not recognized, follow applicable codes.

² Recommended wire sizes are sufficient to restrict voltage drop to the voltage shown in the column heading, or less, at rated full load output current of the system for the loop lengths shown in this column. Loop length is the sum of the lengths of the positive and negative leads.

³ Two-hole lug, 3/8 bolt clearance hole, 1" centers. Lugs should be crimped per lug manufacturer's specifications.

Table 6

SPECIFICATIONS

1. SYSTEM

1.1 Output Ratings

1.1.1 See page 1.

1.2 Environmental Ratings

1.2.1 Operating Ambient Temperature Range: 0 °C to +40 °C (32 °F to +104 °F).

1.2.2 Storage Ambient Temperature Range: -40 °C to +75 °C (-40 °F to +167 °F).

1.2.3 Humidity: This system is capable of operating in an ambient relative humidity range of 0% to 95%, non-condensing.

1.2.4 Altitude: 0 feet (0 meters) to 12,000 feet (3657 meters). Derate operating ambient temperature range by 2 °C per 1000 feet (305 meters) above 5000 feet (1524 meters).

1.2.5 Mounting: This product is intended only for installation in a restricted access location on or above a non-combustible surface.

This product must be located in a controlled environment with access to crafts persons only.

This product is intended for installation in network telecommunication facilities (CO, vault, hut, or other environmentally controlled electronic equipment enclosure).

This product is intended to be connected to the common bonding network in a network telecommunication facility (CO, vault, hut, or other environmentally controlled electronic equipment enclosure).

The DC return connection to this system can remain isolated from system frame and chassis (DC-I).

This system is suitable for installation as part of the Common Bonding Network (CBN).

Clearance requirements are:

- a) Recommended minimum aisle space clearance for the front of each bay is 2'6".
- b) The battery rack is front accessed for installation, operation, and maintenance. Refer to your company's standards for recommended minimum aisle space clearance for the rear of each bay..

1.3 Compliance Information

1.3.1 Safety Compliance: This power board is UL Listed ("c UL") as a DC Power Distribution Center for Communications Equipment. This unit meets the requirements of CSA 22.2, No. 225 and is tested and Certified by UL ("c UL") as a Custom Built Power Distribution Center for Communications Equipment.

1.3.2 Seismic Compliance: NEBS Zone 4 Earthquake compliant with five battery strings.

1.3.3 NEBS Compliance: Compliance verified by a Nationally Recognized Testing Laboratory (NRTL) per GR-1089-CORE and GR-63-CORE. Contact Vertiv for NEBS compliance reports.

MECHANICAL SPECIFICATIONS

Overall Dimensions

Notes:

1. All dimensions are in inches, unless otherwise specified.
2. Weight in LBS.
 (minus batteries)
 Net: 484.50
 Shipping: 517.50
3. Finish: Textured Dark Gray

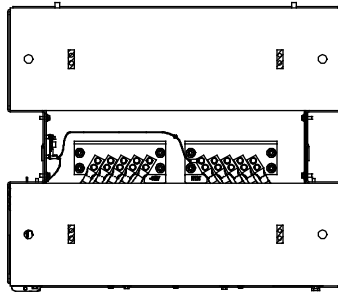

Top View

Battery Tray Internal Dimensions:
 21.2 W x 21.0 D x 11.1 H

Space between Installed Battery
 Trays (from bottom of one tray to
 bottom of next tray): 15

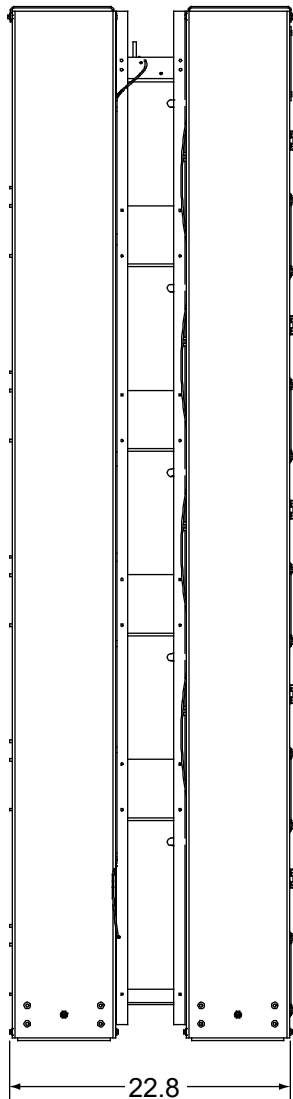

Left Side View

22.8

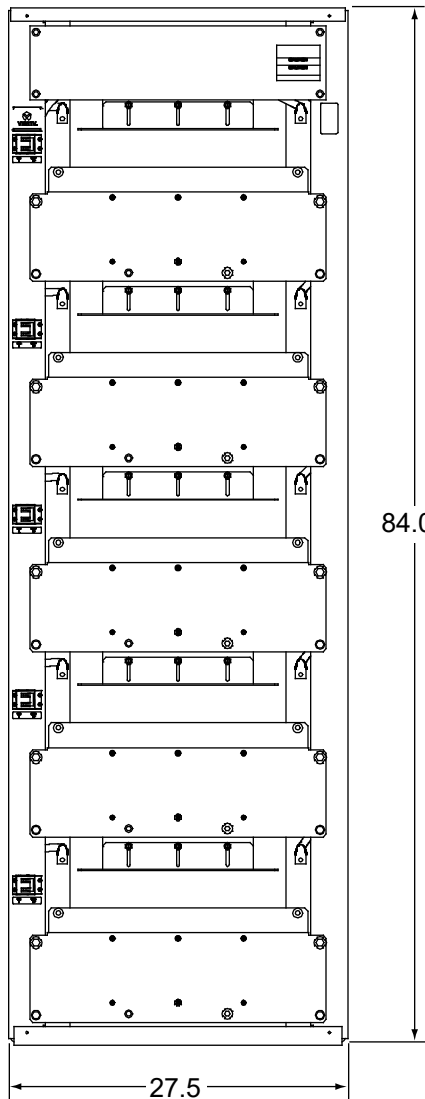

Front View

84.0

27.5

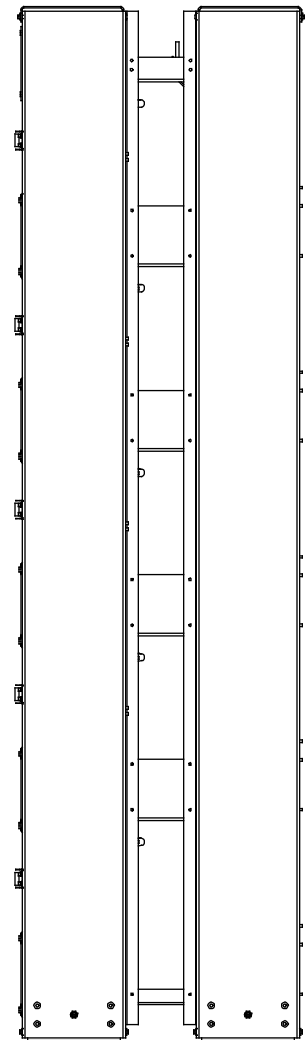

Right Side View

Vertiv™ NetSure™ -48 VDC Battery Rack System

System Application Guide

Dimensions with Battery Retainer Kit (P/N 10010061)

Notes:

1. All dimensions are in inches, unless otherwise specified.
2. Weight in LBS.
(minus batteries)
Net: 484.50
Shipping: 517.50
3. Finish: Textured Dark Gray

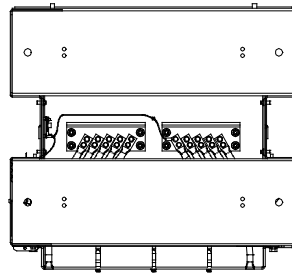

Top View

Battery Tray Internal Dimensions:
21.2 W x 23.2 D x 12.7 H

Space between Installed Battery
Trays (from bottom of one tray to
bottom of next tray): 15

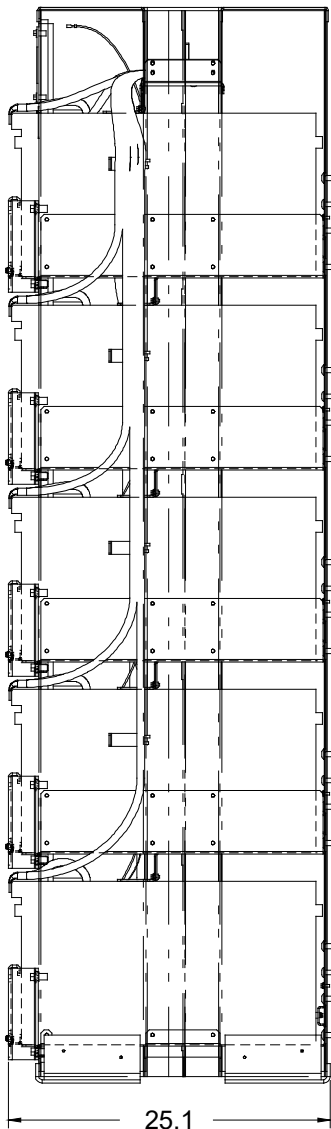

Left Side View

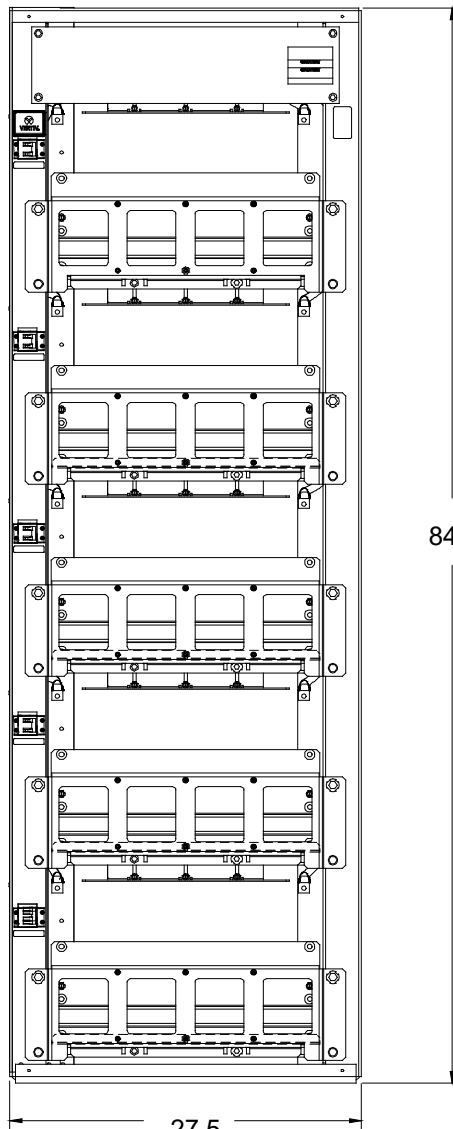

27.5
Front View

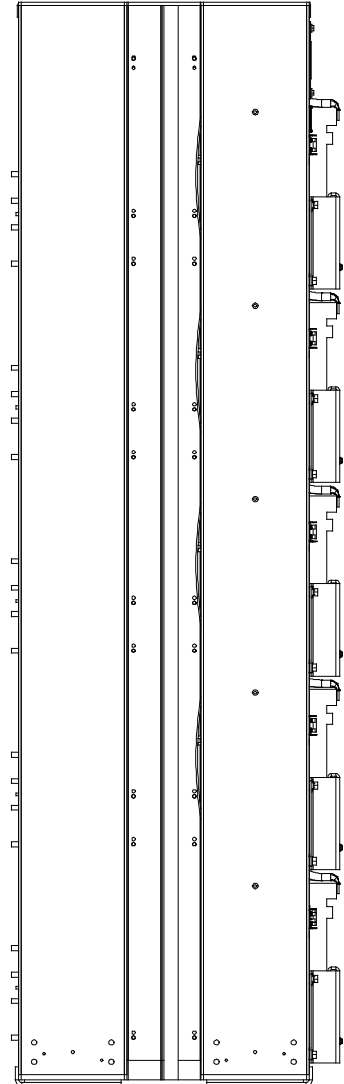

Right Side View

84.0

Floor Mounting Dimensions

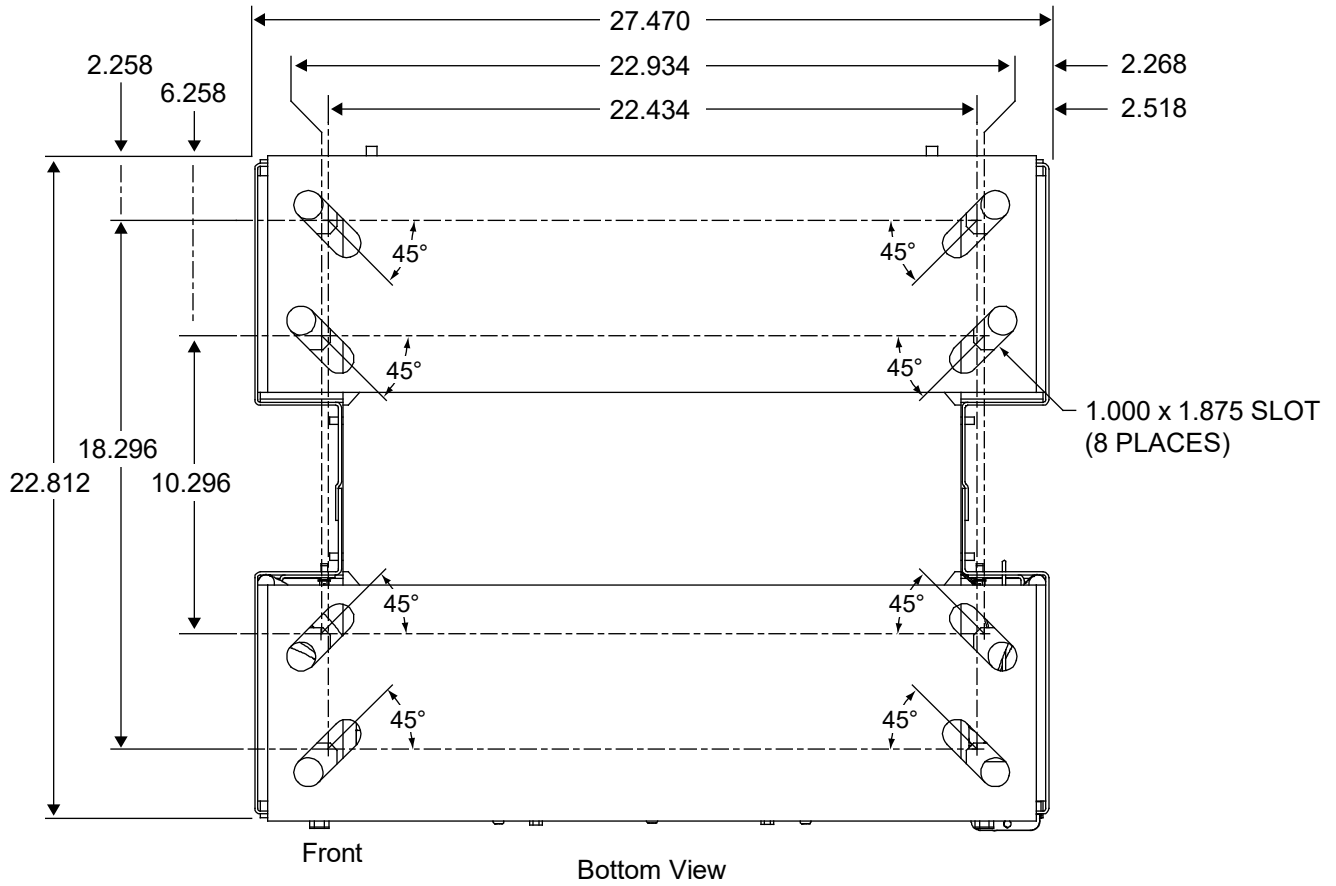

Battery Rack Output Lug Landing Dimensions

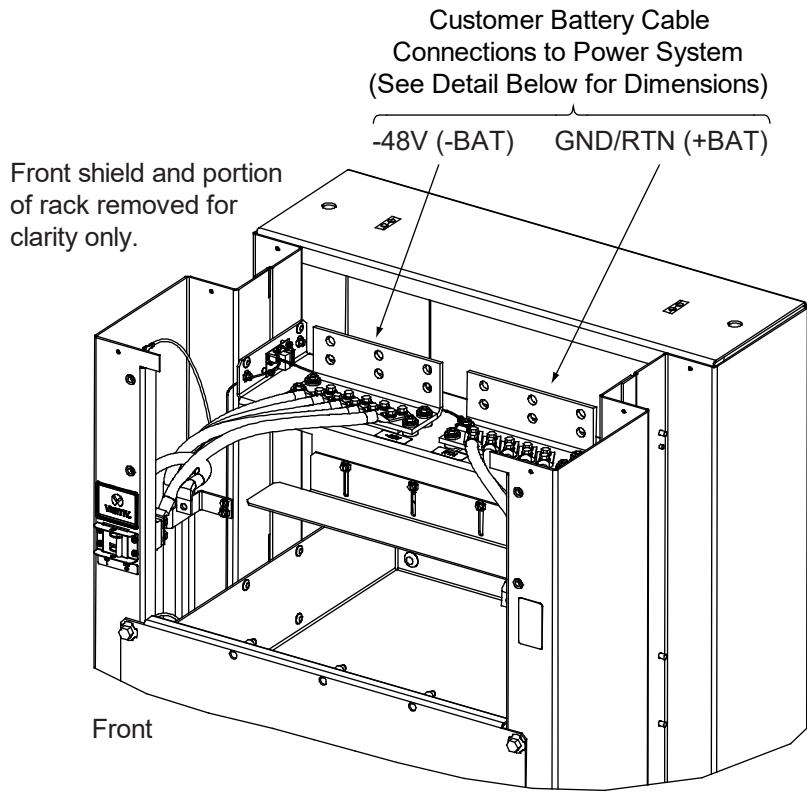

Note: Dimensions are in inches.

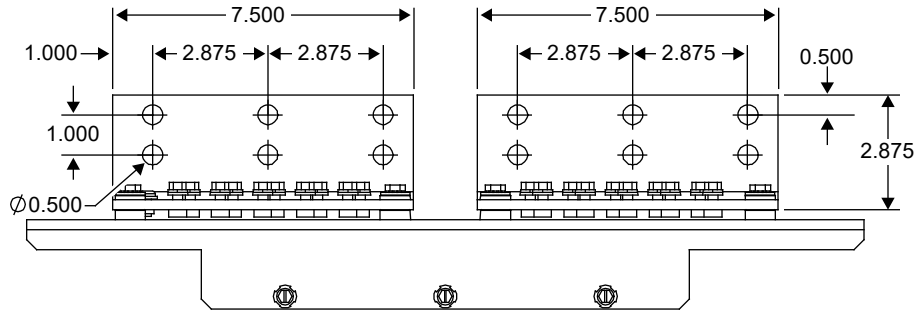

Circuit Breaker Alarms

Front shield and portion
of rack removed for
clarity only.

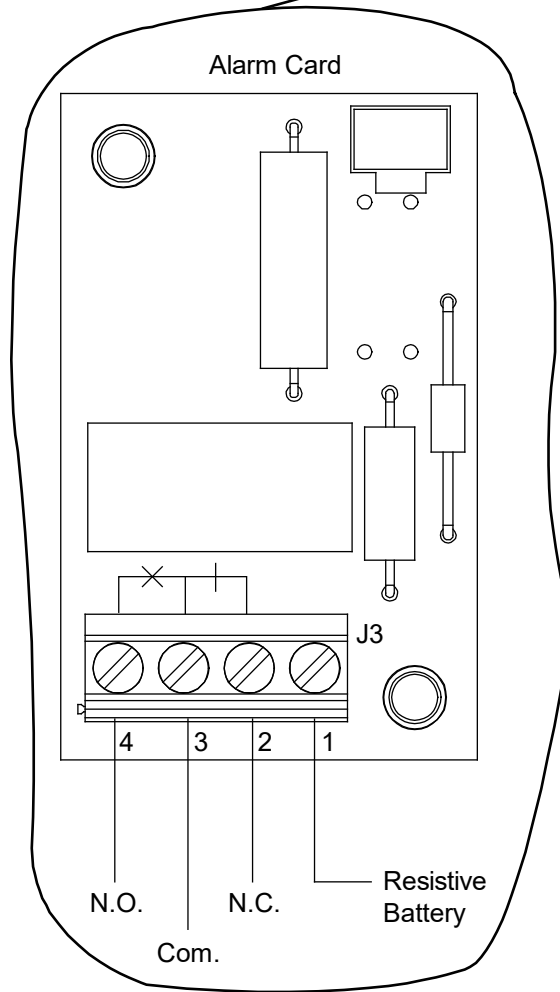
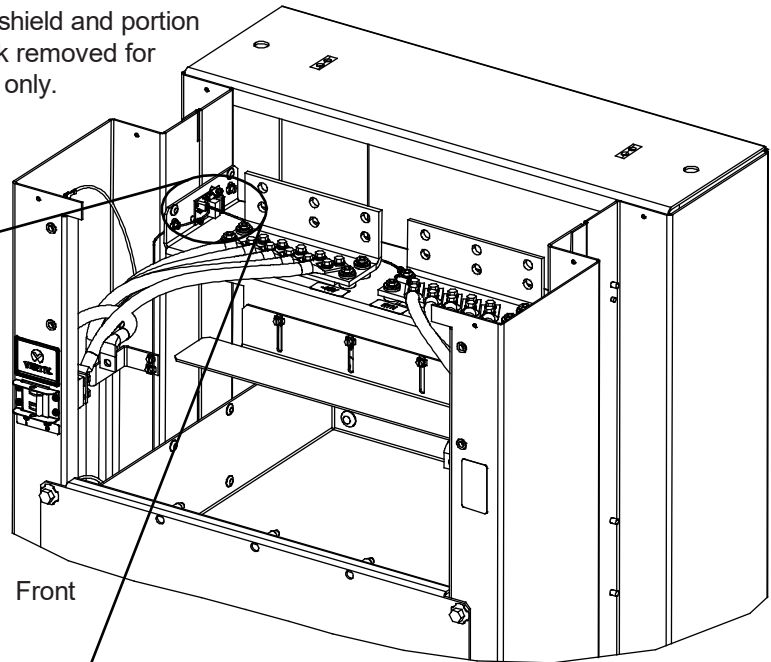

Notes:

Relay shown in deenergized state.

Relay energizes during alarm condition.

N.O. (Normally Open Contact)

Com. (Common)

N.C. (Normally Closed Contact)

Terminal Block (J3) accepts a wire size in the range of 26 AWG to 14 AWG (solid or stranded). Recommended Torque (J3): 4.4 to 5.3 in-lbs.

Vertiv™ NetSure™ -48 VDC Battery Rack System

System Application Guide

BATTERY MANUFACTURER INFORMATION

Some equipment described in this System Application Guide is designed to accommodate batteries from various manufacturers. The following are referenced in this document.

Deka®: East Penn Mfg. Co., Inc., Lyon Station, PA 19536-0147

Marathon™: GNB Industrial Power, a Division of Exide Technologies, Princeton, NJ 08543.

RELATED DOCUMENTATION

System Installation and User Instructions:	IM588820400100
Main Schematic Diagrams:	SD588820400100, SD588820400150, SD588820400200
Main Wiring Diagrams:	T588820400100, T588820400150, T588820400200

Vertiv.com | Vertiv Headquarters, 1050 Dearborn Drive, Columbus, OH, 43085, USA

© 2021 Vertiv Group Corp. All rights reserved. Vertiv™ and the Vertiv logo are trademarks or registered trademarks of Vertiv Group Corp. All other names and logos referred to are trade names, trademarks or registered trademarks of their respective owners. While every precaution has been taken to ensure accuracy and completeness here, Vertiv Group Corp. assumes no responsibility, and disclaims all liability, for damages resulting from use of this information or for any errors or omissions. Specifications, rebates and other promotional offers are subject to change at Vertiv's sole discretion upon notice.

