

2

1

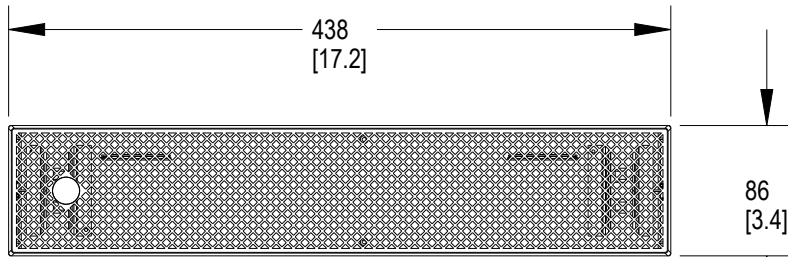

FRONT VIEW

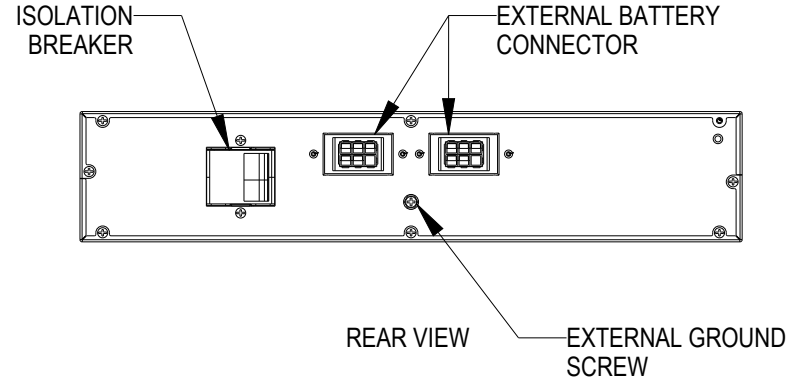

REAR VIEW

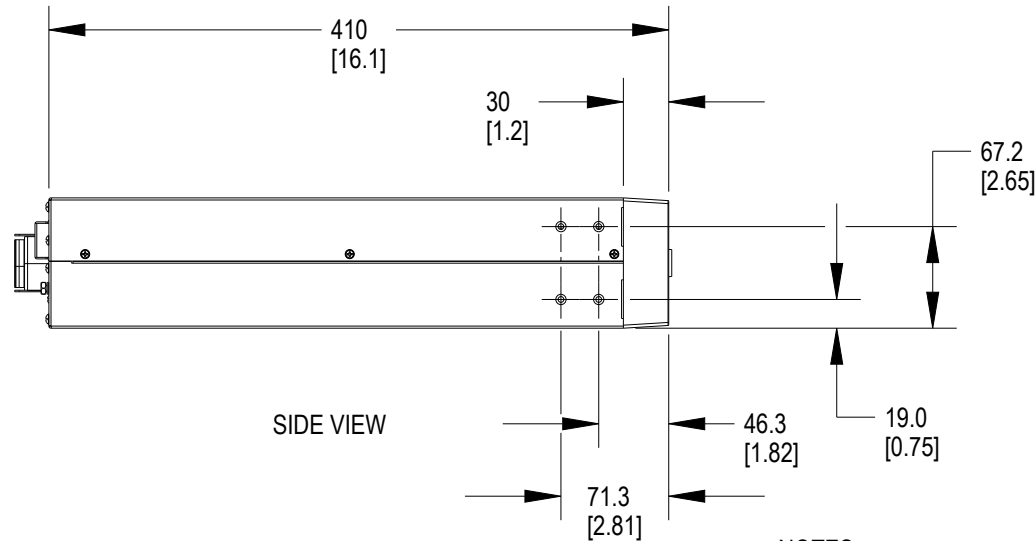

SIDE VIEW

NOTES :

1. UNIT DIMENSIONS (W x D x H) : 438mm x 410mm x 86mm  
(17.2") x (16.1") x (3.4")
2. UNIT WEIGHT WITHOUT EBC : 19.0Kg ( 41.9Lbs)
3. SHIPPING DIMENSIONS (W x D x H) : 560mm x 600mm x 235mm  
(22.0") x (23.6") x (9.3")
4. SHIPPING WEIGHT : 21.1Kg ( 46.7Lbs)
5. MINIMUM AIRFLOW CLEARANCE : 100mm (4.0") FRONT & REAR.

B

B

A

A

SHEET NO. 1 OF 1	DRAWN BY: RINU TOMS	TITLE  OUTLINE DRAWING LIEBERT GXE3 24V EXTERNAL BATTERY CABINET
CO. NO. -	DESIGNED BY: PETE BENNER	
REF DWG. -	APPROVED BY: BAPIN NARAYANKAR	

DWG. NO. GXE3-EBC24VRT2U_OL	
DATE (LATEST REV.) 07-DEC-2023	
REVISION 0	505 N. CLEVELAND AVE WESTERVILLE, OHIO 43082

2

1