

Vertiv™ Liebert® APS Module Replacement

Quick Installation Guide

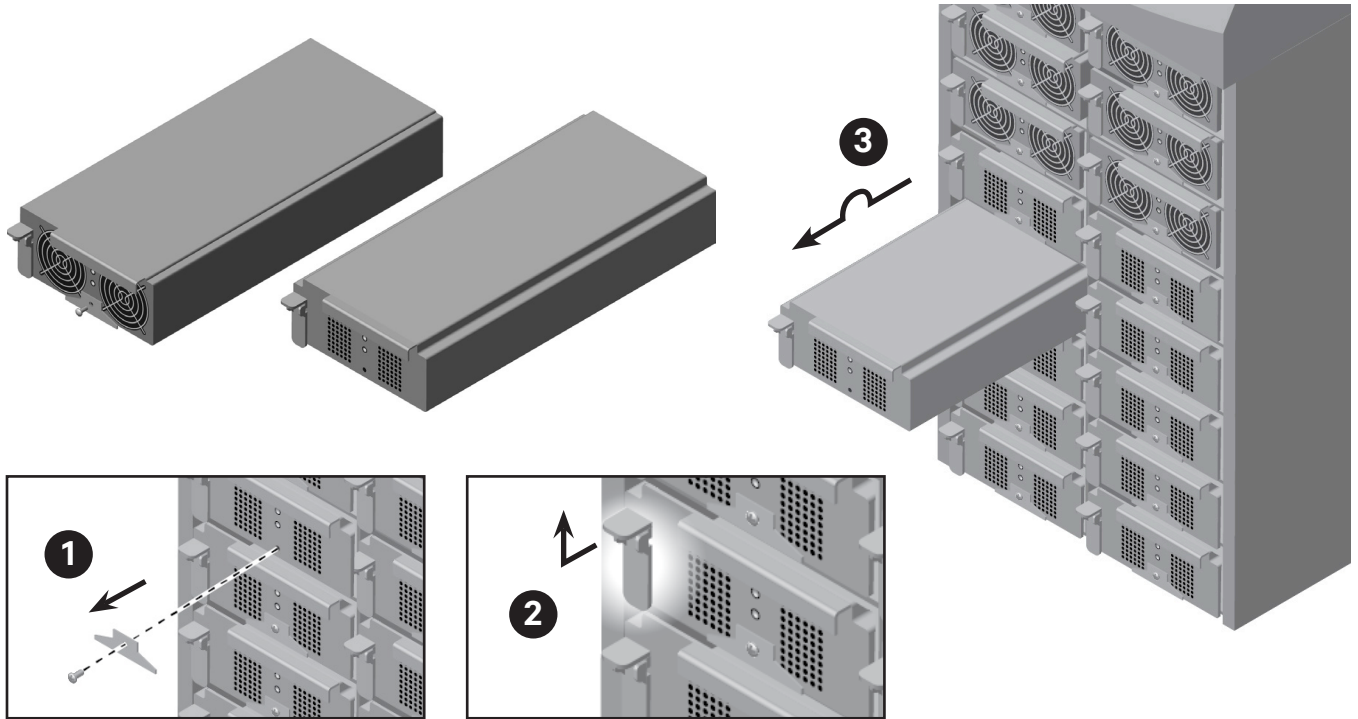

These instructions apply to the replacement or addition of the following modules:

- Power module
- Battery module
- Charger module
- System control module
- System monitoring module

Battery, Power, and Charger Module Removal

WARNING: Risk of heavy unit falling over. Can cause equipment damage, injury or death. Read all of the instructions before attempting to move, lift, remove packaging, or prepare the unit for installation. The UPS represents a tipping hazard.

Do not remove more than one module at a time. Failure to do so may cause unit to tip over and cause serious injury.

To locate a faulty module, remove the bezel cover and look for an illuminated yellow “fault” LED, which indicates a faulty module.

If the removed bezel(s) have air filters, replace them at this time.

NOTE: If your system does not contain a redundant module, place the UPS into manual bypass mode before removing modules to prevent accidental loss of power to the connected equipment.

1. Removing the module-securing bracket

Use a Phillips-head screwdriver to remove the fastener (if installed).

2. Releasing the lock lever

Pull out the lock lever slightly and lift up, then wait a few seconds before continuing.

3. Removing the module from the cabinet bay

Slide the module out about two-thirds of the way until it is stopped by the safety catch.

Lift the module slightly and, while supporting the module, slide it completely out.

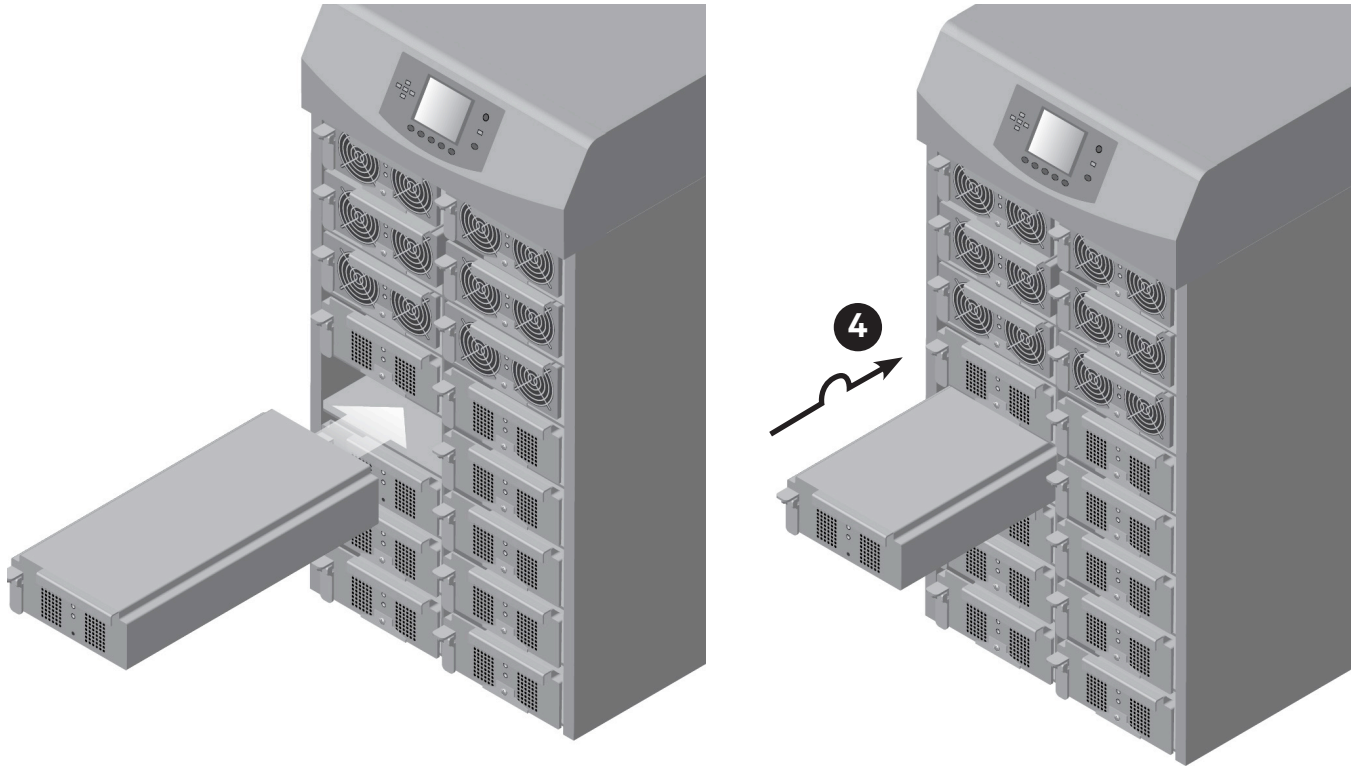

Battery, Power, and Charger Module Installation

4. Inserting a module into a cabinet bay

Lift the module to the appropriate bay, resting the end of the module on the bay shelf.

NOTE: Do not rest the module on any plastic bezels. It could damage the bezel.

NOTE: Two battery modules must be installed in the same row to complete the battery string.

Slowly push the module in until about one-third of the module is in the bay.

Lift the module up, then continue pushing until about 5 cm (2 in.) of the module remains outside the bay, then push it firmly and smoothly to ensure that it is fully inserted.

5. Engaging the lock lever

Pull out the lock lever slightly and press the lever down into the bracket.

NOTE: If the lever does not press down smoothly, remove and reinstall the module.

6. Attaching the module-securing bracket

Use a #2 Phillips-head screwdriver to install the module-securing bracket.

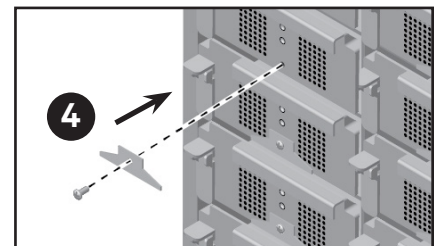
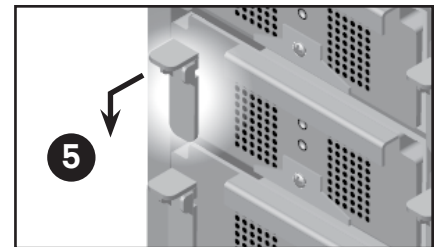

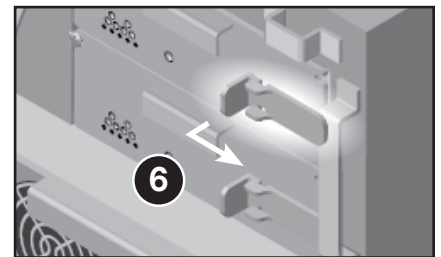
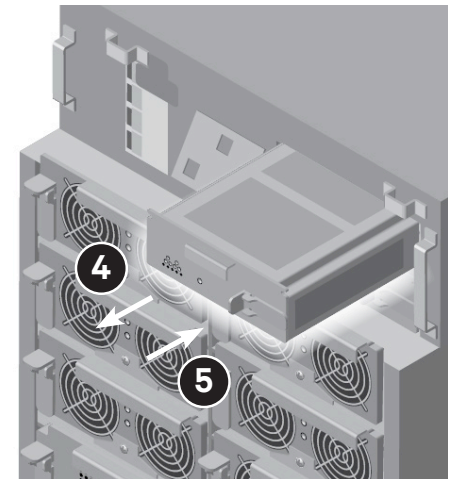
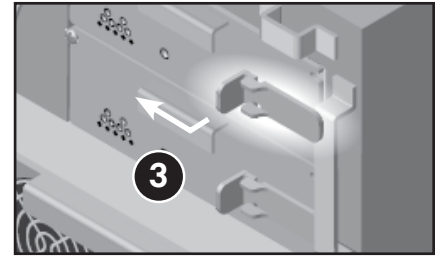
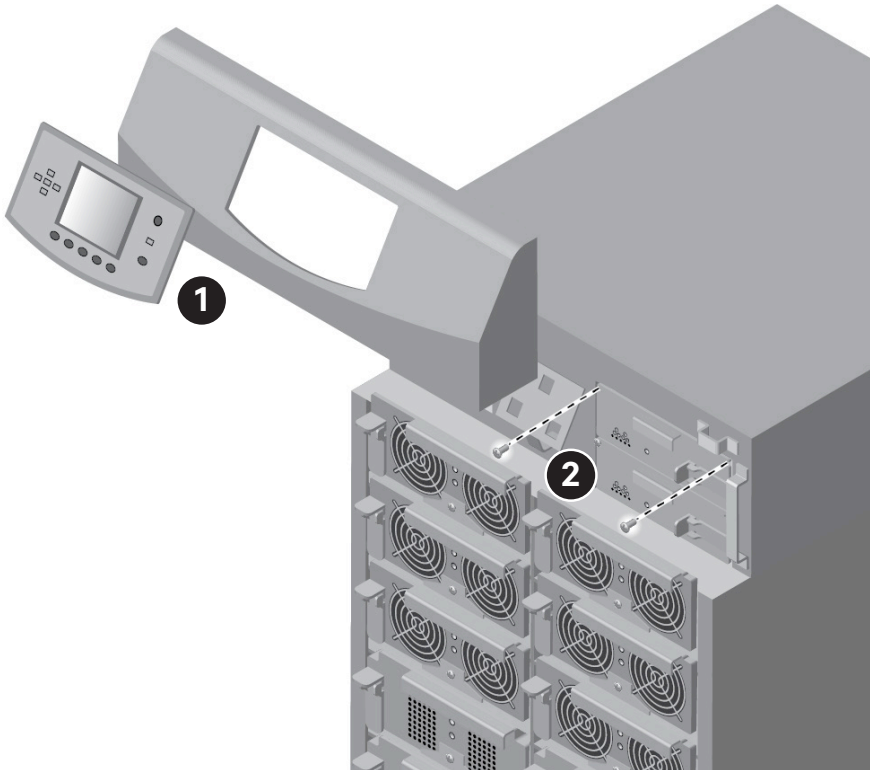

System Control or System Monitoring Module Removal

CAUTION: When both a control and monitoring module need replaced, do not remove them at the same time. If both are removed, the UPS shuts down and power is removed from the connected equipment unless the system includes an external maintenance-bypass system, and the UPS is operating in maintenance-bypass mode.

1. Remove the display bezel and the LCD display.

Lay the display module on top of the UPS.

2. Freeing the module

Use a Phillips-head screwdriver to remove the screws from the 2 securing holes.

3. Releasing the lock lever

Pull out the lock lever slightly and pull to the left, then wait a few seconds before continuing.

4. Removing the module

Being sure to support the module, slide it completely out of its control bay.

NOTE: These modules do not have a safety catch because they are lightweight.

System Control or System Monitoring Module Installation

5. Inserting a module into a control bay

Push the module in until about 1 cm (1/2 in.) of the module remains outside the bay, then push it firmly and smoothly to ensure that it is fully inserted.

6. Engaging the lock lever

Pull out the lock lever slightly and press the lever to the right into the bracket.

7. Re-attaching the module to the cabinet

Use a #2 Phillips-head screwdriver to resecure the module.

8. Replace the LCD display and the display bezel.



To contact Vertiv Technical Support: visit www.Vertiv.com

© 2021 Vertiv Group Corp. All rights reserved. Vertiv™ and the Vertiv logo are trademarks or registered trademarks of Vertiv Group Corp. All other names and logos referred to are trade names, trademarks or registered trademarks of their respective owners. While every precaution has been taken to ensure accuracy and completeness here, Vertiv Group Corp. assumes no responsibility, and disclaims all liability, for damages resulting from use of this information or for any errors or omissions. Specifications, rebates and other promotional offers are subject to change at Vertiv's sole discretion upon notice.

