



Product brochure

Vertiv™ Liebert® GXT5 UPS

500 - 3000VA 120V

Intelligent and efficient UPS for protection
of your mission-critical applications



Intelligent and efficient UPS for protection of your mission-critical applications

The Vertiv™ Liebert® GXT5 UPS is an online double conversion UPS solution which offers premium power outage protection and continuous power conditioning in a compact and flexible rack/tower form factor.

The Vertiv Liebert GXT5 single-phase UPS operates with high power efficiency, making it ideally suited to protect critical infrastructure in both centralized and edge network applications.

Scalable runtime options with matching external battery cabinets offer additional flexibility when extended uninterrupted power is required. Plus, the Vertiv Liebert GXT5 provides battery health status and replacement date prediction for intelligent battery health management.

The UPS system is easy to deploy and maintain due to its user-friendly LCD interface and remote management capabilities supported by the Vertiv™ Liebert® RDU120 communications card which makes the Vertiv Liebert GXT5 compatible with Vertiv™ infrastructure management solutions such as Vertiv™ Life™ Services, environmental sensors, Vertiv™ Power Insight, and more.

With market leading efficiency and unity power factor operation, the Vertiv Liebert GXT5 will meet your critical application needs. And you can rest assured that your business is protected with this Vertiv™ solution that includes a standard, three-year advanced exchange product warranty.

What's in the box

- UPS
- Tower stand
- 4-Post rack mounting kit
- Usb cable
- Quick start guide
- Safety manual
- Vertiv™ Power Insight management software (free download from Vertiv.com)



Vertiv™ Liebert® GXT5 features

Leading UPS technology

- High output power factor = up to 1.0
- Full-color graphic LCD with gravity sensing orientation
- Individually controllable output power sockets
- External battery cabinets with auto-detection
- Battery health status and replacement date prediction
- Remote management, update, and configuration capabilities
- Optimized thermal management and variable speed fan

Efficient and green product

- High efficiency in online mode
- Energy Star 2.0 certified
- Even higher efficiency (up to 98%) in Active ECO mode
- Programmable outlets for power cycling hung equipment and optimum battery usage
- Compliance with Restriction of Hazardous Substances (RoHS) directive and the Registration, Evaluation, Authorization and Restriction of Chemicals (REACH) regulation

Solutions wide

- Compact rack/tower design
- Broad range of services and extended warranty
- Easy to install, configure and operate
- Vertiv Liebert RDU120 network communications card with advanced features
- Compatibility with environmental sensors
- Integrated dry-contacts with selectable definition
- Free Vertiv Power Insight management software
- Serial port for out-of-band management with Vertiv™ Avocent® serial consoles
- Automatic internal bypass and external maintenance bypass options



Vertiv™ Liebert® GXT5 features



High power factor (0.9-1.0)

More usable power enables more connected loads saving space and costs.



Efficiency (up to 98%) in Active ECO mode

Superior protection with maximum efficiency.



Battery cabinets with auto-detection

Be confident the UPS is set up correctly to report available runtime when used with external battery cabinets.



Product warranty

Comprehensive coverage through a standard three-year advanced exchange warranty.

Efficiency (up to 95%) in online mode Energy Star Certified



High energy efficiency saves on energy costs and reduces heat dissipation from the UPS.

Colored graphic LCD with gravity sensitive orientation



User-friendly interface provides insight to UPS status for easy installation, configuration and operation.

Compact rack/tower design

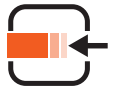

Space-saving UPS provides rack space optimization and flexible installation.



500-1500VA – 120V Rack/Tower

External battery connector
Scalable runtime solution supported for extended outage protection

4 X individually controllable receptacle
Manage load on battery and control unauthorized access to UPS receptacle

Communications
SNMP, Serial, Dry contact, Local USB
Local and remote configuration and UPS Management

NEMA 5/15P input with over current protection
Simple installation and power on with connected input cord

2000VA – 120V Rack/Tower

External battery connector
Scalable runtime solution supported for extended outage protection

NEMA L5-20R
Support larger devices or rack PDU

4x individually controllable receptacle, 2x always on receptacles
Manage load on battery and control unauthorized access to UPS receptacle

Communications
SNMP, Serial, Dry contact, Local USB
Local and remote configuration and UPS Management

NEMA L5-20P input with over current protection
Includes NEMA 5-20 Adapter Cable for non-locking receptacles

3000VA – 120V Rack/Tower

External battery connector
Scalable runtime solution supported for extended outage protection

NEMA L5-30R
Support larger devices or rack PDU

4x individually controllable receptacle, 2x always on receptacles
Manage load on battery and control unauthorized access to UPS receptacle

Communications
SNMP, Serial, Dry contact, Local USB
Local and remote configuration and UPS Management

NEMA L5-30P input with over current protection
Simple installation and power on with connected input cord



How you benefit from the Vertiv™ Liebert® GXT5 UPS

Designed for high availability



- The higher power factor (0.9 - 1.0) allows the connection of more loads and IT equipment
- With individually controlled output receptacles, you can manage power to individual devices without impacting other critical network equipment operation
- Minimum downtime of the device provided by hot-swappable, user-replaceable battery modules which can be changed during operation
- Vertiv™ Life™ Services helps to enhance uptime, as well as operational efficiency with continuous remote monitoring, expert analysis, and proactive response
- Automatic self-test

User-friendly installation and operation



- Easy-to-read, gravity-sensing graphical color display
- Intuitive user interface for local configuration and management
- Support for the Vertiv™ suite of remote management tools (Vertiv™ Liebert® Power Insight, RDU120 network interface card, and serial connectivity support)
- Auto-detection of external battery cabinets enables faster deployment and accurate runtime information
- Remote UPS firmware upgrade capability ensures the UPS has the latest features and enhancements

Longer service life and runtime of the batteries

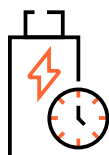

- Extended runtimes provided by the addition of external battery cabinets
- Improved battery care by temperature-compensated battery charging
- Intelligent battery health management ensures a longer service life (optimized battery maintenance and replacement when needed)

Optimized energy and capacity management

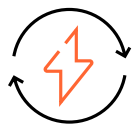

- Active ECO operating mode with up to 98% efficiency
- Efficiency in online double conversion mode up to 95%
- Energy Star 2.0 certified
- Four individually programmable output receptacles can be use to extend runtime for the most critical loads and smart disconnection of the less critical ones

Seamless connectivity

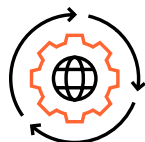

- Four onboard, user-definable dry contact I/O for integration of support management systems
- Supports SNMP, web, and environmental sensors with the optional network communications card
- Serial connection for integration of Vertiv™ Avocent® ACS product or direct serial management and control of the UPS

Power Assurance Package: comprehensive service support for critical systems

- **Five-year protection plan** with 100% parts coverage and 24x7 emergency service
- **On-site installation and startup** of UPS and internal batteries (excludes hard-wired applications); configuration of new UPS and accessories; and if purchased, safe removal and disposal of legacy UPS and batteries
- **On-site service support** available 24x7 (within 150 miles of regional service center) and includes 100% labor and travel coverage
- **100% parts coverage** for UPS and includes internal batteries, POD (power output distribution), and web card
- **24x7 access** to customer resolution center and online access to Customer Services Network

Key benefits:

- Hassle-free management of multi-site rollouts
- Frees up time-strapped IT staff by managing and tracking UPS health, maintenance and service
- Reduces the worry of critical equipment downtime
- Allows rapid recovery in the event of failure (within 24-48 hours)
- Frees you from the responsibility of handling and documenting the disposal of legacy UPS and batteries

Remote diagnostic services for rapid response

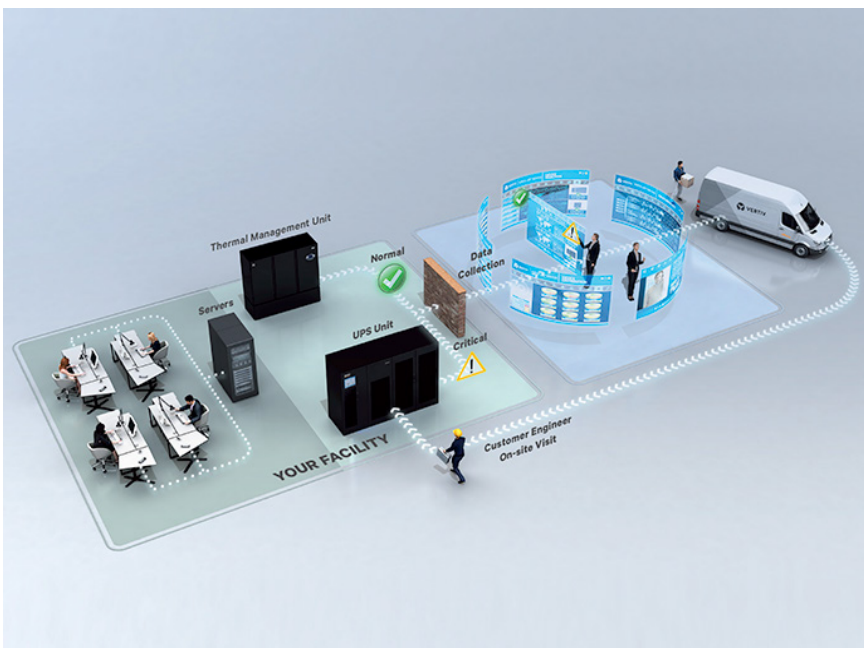

Refer to page 11 for service offerings' SKUs

Uptime assurance

- Continuous monitoring for early detection of trends and operating anomalies
- Analysis and interpretation of alarm and status messages

Rapid incident response

- Automatic transmission of data for analysis
- Concurrent diagnosis and dispatch of engineer to site
- Shipment of parts for corrective maintenance

Increased insight and ease of management

- Notification of operating conditions that may impact system health
- Periodic trend and analysis reports
- Integration of remote and on-site services to enable business continuity



Technical Specifications

Standard models with RDU120 network card	Vertiv™ Liebert® GXT5-500LVRT2UXL	Vertiv™ Liebert® GXT5-750LVRT2UXL	Vertiv™ Liebert® GXT5-1000LVRT2UXL	Vertiv™ Liebert® GXT5-1500LVRT2UXL	Vertiv™ Liebert® GXT5-2000LVRT2UXL	Vertiv™ Liebert® GXT5-3000LVRT2UXL
	Vertiv™ Liebert® GXT5-500LVRT2UXLN	Vertiv™ Liebert® GXT5-750LVRT2UXLN	Vertiv™ Liebert® GXT5-1000LVRT2UXLN	Vertiv™ Liebert® GXT5-1500LVRT2UXLN	Vertiv™ Liebert® GXT5-2000LVRT2UXLN	Vertiv™ Liebert® GXT5-3000LVRT2UXLN
Ratings (VA/W)	500VA/500W	750VA/750W	1000VA/1000W	1500VA/1350W	2000VA/1800W	3000VA/2700W
Dimensions, inches (mm)						
Unit W x D x H	16.9 x 15.7 x 3.4 (430 x 400 x 85)	16.9 x 15.7 x 3.4 (430 x 400 x 85)	16.9 x 15.7 x 3.4 (430 x 400 x 85)	16.9 x 18.5 x 3.4 (430 x 470 x 85)	16.9 x 18.5 x 3.4 (430 x 470 x 85)	16.9 x 21.3 x 3.4 (430 x 540 x 85)
Weight, pounds (kg)						
Unit	37 (16.8)	37 (16.8)	37 (16.8)	46.2 (21)	47.5 (21.6)	66(30)
Input AC parameters						
Range	Typical 120V Range: 60-150V	Typical 120V Range: 60-150V	Typical 120V Range: 60-150V	Typical 120V Range: 60-150V	Typical 120V Range: 60-150V	Typical 120V Range: 60-150V
Frequency	40-70Hz; Auto sensing	40-70Hz; Auto sensing	40-70Hz; Auto sensing	40-70Hz; Auto sensing	40-70Hz; Auto sensing	40-70Hz; Auto sensing
Input power cord	10 ft. attached w/ NEMA 5-15P plug	10 ft. attached w/ NEMA 5-15P plug	10 ft. attached w/ NEMA 5-15P plug	10 ft. attached w/ NEMA 5-15P A plug	NEMA L5-20P or 5-20P plug (5-20P adapter included)	10 ft. attached w/ NEMA L5-30P plug
Output AC parameters						
Output receptacles	5-15R x 6	5-15R x 6	5-15R x 6	5-15R x 6	L5-20R+5-20R x 6	L5-30R+5-20R x 6
Typical 120V	110/115/120/125VAC	110/115/120/125VAC	110/115/120/125VAC	110/115/120VAC	110/115/120VAC	110/115/120VAC
User selectable output	(user-configurable); ±3%	(user-configurable); ±3%	(user-configurable); ±3%	(user-configurable); ±3%	(user-configurable); ±3%	(user-configurable); ±3%
Waveform	Sine wave	Sine wave	Sine wave	Sine wave	Sine wave	Sine wave
Utility (AC) mode overload	>200% for 250ms; 150- 200% for 50 seconds; 125- 150% for 60 seconds; 105-125% for 60 seconds	>200% for 250ms; 150- 200% for 50 seconds; 125- 150% for 60 seconds; 105-125% for 60 seconds	>200% for 250ms; 150- 200% for 50 seconds; 125- 150% for 60 seconds; 105-125% for 60 seconds	>200% for 250ms; 150- 200% for 2 seconds; 125- 150% for 50 seconds; 105-125% for 60 seconds	>200% for 250ms; 150- 200% for 2 seconds; 125- 150% for 50 seconds; 105-125% for 60 seconds	>200% for 250ms; 150- 200% for 2 seconds; 125- 150% for 10 seconds; 105-125% for 15 seconds
Battery						
Type	Valve-regulated, non-spillable, lead acid	Valve-regulated, non-spillable, lead acid	Valve-regulated, non-spillable, lead acid	Valve-regulated, non-spillable, lead acid	Valve-regulated, non-spillable, lead acid	Valve-regulated, non-spillable, lead acid
Backup time (100% load)	17.9	10.4	6.7	6.7	4	4
Backup time (50% load)	40.4	25.5	17.9	18.8	12.3	12.6
+1 External battery cabinet (100% load)	76.3	45.4	32.6	32.4	22	22.2
+1 External battery cabinet (50% load)	147.8	102.4	76.5	79.7	53.6	54.6
Environmental requirements						
Operating temperature, °F (°C)	+32 to +104 (0 to 40)	+32 to +104 (0 to 40)	+32 to +104 (0 to 40)	+32 to +104 (0 to 40)	+32 to +104 (0 to 40)	+32 to +104 (0 to 40)
Storage temperature, °F (°C)	-4 to +140 (-20 to 60) contain batteries will be from -15 to 40°C.	-4 to +140 (-20 to 60) contain batteries will be from -15 to 40°C.	-4 to +140 (-20 to 60) contain batteries will be from -15 to 40°C.	-4 to +140 (-20 to 60) contain batteries will be from -15 to 40°C.	-4 to +140 (-20 to 60) contain batteries will be from -15 to 40°C.	-4 to +140 (-20 to 60) contain batteries will be from -15 to 40°C.
Relative humidity	0% to 95%, non-condensing	0% to 95%, non-condensing	0% to 95%, non-condensing	0% to 95%, non-condensing	0% to 95%, non-condensing	0% to 95%, non-condensing
Operating elevation	10,000 ft. (3,000m)	10,000 ft. (3,000m)	10,000 ft. (3,000m)	10,000 ft. (3,000m)	10,000 ft. (3,000m)	10,000 ft. (3,000m)
Storage elevation	50,000 ft. (15,000m)	50,000 ft. (15,000m)	50,000 ft. (15,000m)	50,000 ft. (15,000m)	50,000 ft. (15,000m)	50,000 ft. (15,000m)
Audible noise	<46dBA max @ 3 ft. (1m) front and sides < 43dBA, at 3 ft. (1m) rear	<46dBA max @ 3 ft. (1m) front and sides < 43dBA, at 3 ft. (1m) rear	<46dBA max @ 3 ft. (1m) front and sides < 43dBA, at 3 ft. (1m) rear	< 46dBA at 3 ft. (1m) front and side < 45dBA at 3 ft. (1m) rear	<48dBA max @ 3 ft. (1m) front and side <48dBA max @ 3 ft. (1m) rear	<48dBA max @ 3 ft. (1m) front and side <48dBA max @ 3 ft. (1m) rear
Agency						
Surge immunity Transportation	ANSI C62.41 Category B ISTA Procedure 1A	ANSI C62.41 Category B ISTA Procedure 1A	ANSI C62.41 Category B ISTA Procedure 1A	ANSI C62.41 Category B ISTA Procedure 1A	ANSI C62.41 Category B ISTA Procedure 1A	ANSI C62.41 Category B ISTA Procedure 1A
Safety	UL 1778 4th Edition and CSA 22.2 No 107.3	UL 1778 4th Edition and CSA 22.2 No 107.3	UL 1778 4th Edition and CSA 22.2 No 107.3	UL 1778 4th Edition and CSA 22.2 No 107.3	UL 1778 4th Edition and CSA 22.2 No 107.3	UL 1778 4th Edition and CSA 22.2 No 107.3
Emissions	FCC Part 15 (Class A) - CISPR22 Class A (RFI)	FCC Part 15 (Class A) - CISPR22 Class A (RFI)	FCC Part 15 (Class A) - CISPR22 Class A (RFI)	FCC Part 15 (Class A) - CISPR22 Class A (RFI)	FCC Part 15 (Class A) - CISPR22 Class A (RFI)	FCC Part 15 (Class A) - CISPR22 Class A (RFI)
Environmental	WEEE and ROHS2 REACH	WEEE and ROHS2 REACH	WEEE and ROHS2 REACH	WEEE and ROHS2 REACH	WEEE and ROHS2 REACH	WEEE and ROHS2 REACH
Warranty						
	Std. 3 year; Opt. 2 year	Std. 3 year; Opt. 2 year	Std. 3 year; Opt. 2 year	Std. 3 year; Opt. 2 year	Std. 3 year; Opt. 2 year	Std. 3 year; Opt. 2 year
Protection plan						
Equipment Protection Plan	\$500,000					

Vertiv™ VR Rack

Supports a wide variety of equipment and gives you the flexibility you need with easy installation

Vertiv™ PowerIT rPDU

Reliably distributes power to the rack, supporting dynamic data center operations and DCIM

Vertiv™ SwitchAir™

Prevents overheating of network switches by directing cool air to switch intakes, keeping hot exhaust air out

Vertiv™ Avocent®

ACS Console
Enables integrated remote monitoring, out-of-band management, and IoT connectivity

Vertiv™ KVM Switch

Enables single-point access for switching between multiple computers

Vertiv™ Rack Cooling

Provides energy-efficient cooling close to the IT equipment and UPS units

Vertiv™ Liebert® GXT5

Helps protect mission-critical equipment from all power disturbances due to blackouts, brownouts, sags, surges or noise interference

Accessories

- **Racks and enclosures:** Support a wide variety of equipment with the Vertiv™ VR Rack including servers, storage, switches, routers, PDUs, UPS units, console port servers, and KVM switches.
- **Rails and mounting hardware:** Install equipment with a four-post rail kit and hardware for mounting in a 19- or 23-inch rack or choose a two-post telecom rack for front- or mid-chassis, wall, or Zero U configuration.
- **Rack mount PDUs:** For basic or intelligent power distribution that helps prevent overloaded circuits in the data center, choose from products such as upgradable PDUs, inline power meters, transfer switches, and monitoring sensors.
- **Extended battery modules:** Enable scalable runtime for support during extended power outage situations by adding reliable power and protection to new or existing deployments.
- **Environmental sensor:** Maintain knowledge of remote environments with temperature, humidity and leak detection, or monitor available dry-contact sensors for security access control or smoke detection.



Available accessories for the Vertiv™ Liebert® GXT5 UPS



External battery cabinets and replacement battery kits

UPS	External battery cabinets	Replacement battery kits
GXT5-500LVRT2UXL	GXT5-EBC36VRT2U	GXT5-36VBATKIT
GXT5-750LVRT2UXL	GXT5-EBC36VRT2U	GXT5-36VBATKIT
GXT5-1000LVRT2UXL	GXT5-EBC36VRT2U	GXT5-36VBATKIT
GXT5-1500LVRT2UXL	GXT5-EBC48VRT2U	GXT5-48VBATKIT
GXT5-2000LVRT2UXL	GXT5-EBC48VRT2U	GXT5-48VBATKIT
GXT5-3000LVRT2UXL	GXT5-EBC72VRT2U	GXT5-72VBATKIT



Vertiv™ Liebert® RDU101 network card

Network Communication Cards and environmental sensors

Optional Intellislot cards are compatible with all Vertiv™ Liebert® GXT5 UPS systems

	Card/Kit	Description
Network communications	RDU120	Network Communication Card with 10/100/1000 Mbps Ethernet, web interface, MIB, configuration cable, and environmental sensor support, UL 2900 certified.
	RDU101	Vertiv™ Liebert® IntelliSlot™ web card for SNMP and web management. Supports environmental sensors.
	IS-RELAY	Vertiv™ Liebert® IntelliSlot™ Interface Kit for Relay Contacts
Vertiv™ Liebert® RDU101 Card Environmental Sensors*	SN-Z01	Integrated cable with single temperature sensor
	SN-Z02	Integrated cable with three temperature sensors
	SN-Z03	Integrated cable with three temperature and one humidity sensors
	SN-T	Modular with single temperature sensor
	SN-TH	Modular with single temperature and single humidity sensor
	SN-2D	Modular with two door contact inputs
	SN-3C	Modular with three dry contact inputs
	SN-L20	Modular leak zone sensor with 20 foot cable (Liebert RDU-S only)
Vertiv™ Liebert® IntelliSlot™ RDU120 Card Environmental Sensors**	A2D-10	Analog to digital converter provides the ability to connect a dry contact, 0-10V, or 4-20mA sensor to a Plug-n-Play sensor port. Includes a 10ft / 3m cable.
	A2D-50	Analog to digital converter provides the ability to connect a dry contact, 0-10V, or 4-20mA sensor to a Plug-n-Play sensor port. Includes a 10ft / 3m cable.
	GT3HD	Temperature, humidity, and dew point sensor with dual inputs for included 3ft / .9m and 6ft / 1.8m temperature sensors for monitoring top, middle, and bottom of a rack or cabinet. Includes a supplementary input for daisy-chaining additional sensors. Includes 10ft / 3m cable.
	GT3HD-50	Temperature, humidity, and dew point sensor with dual inputs for included 3ft / .9m and 6ft / 1.8m temperature sensors for monitoring top, middle, and bottom of a rack or cabinet. Includes a supplementary input for daisy-chaining additional sensors. Includes 50ft / 15.2m cable.
	GTHD	Temperature, humidity, and dew point sensor. Includes a supplementary input for daisy-chaining additional sensors. Includes 10ft / 3m cable.
	GTHD-50	Temperature, humidity, and dew point sensor. Includes a supplementary input for daisy-chaining additional sensors. Includes 50ft / 15.2m cable.
	SRT-12	Temperature sensor used to monitor temperature in critical environments. Includes a 12ft / 3.6m cable.
	SRT-20	Temperature sensor used to monitor temperature in critical environments. Includes a 20ft / 6.1m cable.
	SRT-50	Temperature sensor used to monitor temperature in critical environments. Includes a 50ft / 15.2m cable.
	SRT-100	Temperature sensor used to monitor temperature in critical environments. Includes a 100ft / 30.4m cable.
	RTAFHD3-12	Temperature, airflow, humidity, and dew point sensor. Includes 12ft / 3.6m cable.
	RTAFHD3-20	Temperature, airflow, humidity, and dew point sensor. Includes 20ft / 6.1m cable.
	RTAFHD3-50	Temperature, airflow, humidity, and dew point sensor. Includes 50ft / 15.2m cable.
	RTAFHD3-100	Temperature, airflow, humidity, and dew point sensor. Includes 100ft / 30.4m cable.
	FS-15	0-5VDC conductivity based flood sensor used to detect the presence of water. Includes a 15ft / 4.5m cable.
	FS-100	0-5VDC conductivity based flood sensor used to detect the presence of water. Includes a 100ft / 30.4m cable.
	RDPS	Magnetic normally-closed dry-contact sensor used to monitor remote door position. Includes 30ft / 9.1m cable.
RDPS-50	Magnetic normally-closed dry-contact sensor used to monitor remote door position. Includes 50ft / 15.2m cable.	
RDPS-100	Magnetic normally-closed dry-contact sensor used to monitor remote door position. Includes 100ft / 30.4m cable.	
PFS-100 US	0-5V power failure sensor to monitor the presence of utility power. Includes a 100ft / 30.4m cable and US NEMA power supply	

* Only compatible with Vertiv™ Liebert® IntelliSlot™ RDU101 Network Card

**Only compatible with Vertiv™ Liebert® IntelliSlot™ RDU120 Network Card



Vertiv™ Liebert® MicroPOD - Maintenance bypass and output distribution

The Vertiv Liebert MicroPOD (Power Output Distribution) is a maintenance bypass option for UPS products, 3 kVA and below. It allows removal of the UPS without powering down the connected equipment. The 2U POD's can be installed on the floor or mounted to a Vertiv™ Liebert® GXT5 UPS using the included mounting brackets.

UPS VA rating	POD model number	Output receptacles	Plug to utility
500-1500VA UPS	MP2-115HW	Hardwired	Hardwired
	MP2-115A	8 x 5-15R	5-15P
2000VA UPS	MP2-120HW	Hard Wired	Hardwired
	MP2-120C	8 x 5-15/20R	5-20P
	MP2-120E	4 x 5-15/20R; 1 x L5-20R	5-20P
3000VA UPS	MP2-130HW	Hardwired	Hardwired
	MP2-130C	8 x 5-15/20R	L5-30P
	MP2-130E	2 x 5-15/20R; 1 x L5-30R; 4 x 5-15/20R	L5-30P
	MP2-130P	4 x 5-15R; 2 x L5-20R	L5-30P

Vertiv™ UPS software benefits ladder

Feature	Vertiv™ Power Assist	Vertiv™ Power Insight	Vertiv™ Environet™ Alert	Vertiv™ Avocent® DSView™ Solutions	Vertiv™ Environet™ Connect
Management					
Mass device provisioning					•
Mass device configuration					•
Mass firmware upgrade				•	•
Hypervisor plugin		vCenter, vXRail, Nutanix			
Automated server shutdown	•	•			
Reporting					
Analytics and reporting			•		•
Historical data		•	•		•
Thresholds and alerts		•	•	•	•
Alarm management	•	•	•	•	•
Monitoring					
IT device monitoring				•	
Thermal monitoring			•		•
Power monitoring	UPS only	UPS and rack PDU	•	UPS, rack PDU, servers	•
Specifications					
Protocol support	USB/SNMP	SNMP	SNMP, Modbus TCP, BACnet IP	SNMP, IPMI, Redfish	SNMP
Equipment support	Vertiv only	Vertiv only	Multi-vendor	Multi-vendor	Multi-vendor
Max. devices support	2	100	Scalable	Scalable	Scalable
Software architecture	On-prem	On-prem	On-prem	On-perm	Multi-tenant cloud based
Licensing	Free	Free	Perpetual	Subscription	Subscription



2POSTRMKIT

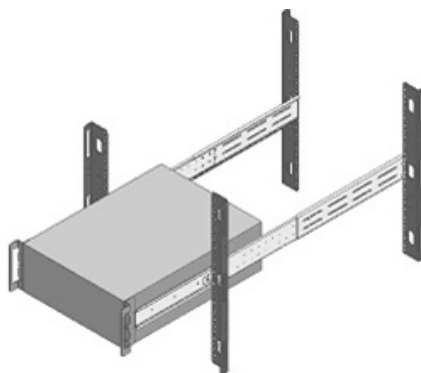

Rack slide kits for all Vertiv™ Liebert® GXT5 rack tower models (RMKIT 18-32)

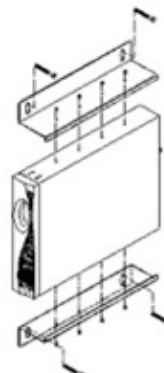

Wall mount bracket kit for Vertiv™ Liebert® GXT5 500VA – 3000VA models WMBKT2U and WMBKT2U-SS

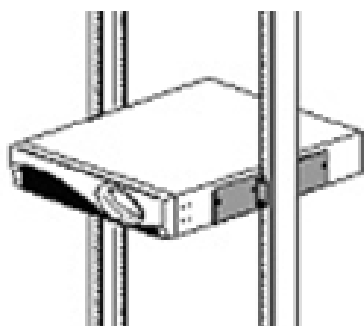

ZUTELECOMRKIT

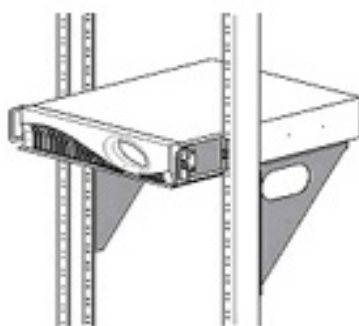

Rack shelves - center mount shown RS600 / RS800

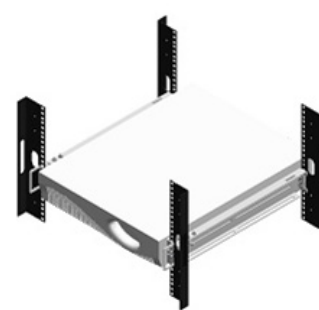

Standard kit included inside the UPS box VRMKIT18-32

Mounting Kit Options

Application	Model supported	Style	Model	Description
2 Post rack	Vertiv™ Liebert® GXT5 UPS family (500VA to 10kVA)	Shelf	RS500	Flush-mount shelf for 19" rack wide
		Shelf	RS600	Center-mount shelf for 19" rack wide
		Shelf	RS700	Flush-mount shelf for 23" rack wide
		Shelf	RS800	Center-mount shelf for 23" rack wide
	Vertiv™ Liebert® GXT5 up to 3kVA	Bracket	ZUTELECOMRKIT	Only center-mount bracket for 19" rack wide
		Bracket	2POSTRMKIT	Front flush/ center-mount bracket - 4-piece design
Wall mount	Vertiv™ Liebert® GXT5 up to 3kVA	Bracket	WMBKT2U	Wall mount bracket holds (1) GXT5 2U or (1) PS15 2U product, steel painted black
		Bracket	WMBKT2USS	Wall mount bracket holds (1) GXT5 2U or (1) PS15 2U product, stainless steel
4 Post rack	Entire Vertiv™ Liebert® GXT5 UPS family (500VA to 10kVA)	Bracket	RMKIT18-32	Cabinet/racks with 18" - 32" deep support rails - Telescopic rail

Note: RS600 and RS800 kits include adapter brackets for installation of up to (2) Vertiv™ Liebert® GXT5 2U model

Vertiv™ Liebert® GXT5 UPS - Power Assurance Services

Power Assurance Package

Bundled start-up service and 5-year on-site emergency response	Standard	With Vertiv™ Life™ Services	With removal	Vertiv™ With Life™ and removal
Vertiv equipment model / type	Part number	Part number	Part number	Part number
Vertiv™ Liebert® GXT5 UP TO 3 KVA	PAPGXT-1K3K	PAPGXT-1K3KLF	PAPGXT-1K3KRMV	PAPGXT-1K3KRLF
External battery cabinet (36V or 48V or 72V)	PAPGXT-BATT	N/A	PAPGXT-BATTRMV	N/A

Power Startup Services

Startup service only	Standard	With removal
Equipment model / type	Part number	Part number
Vertiv™ Liebert® GXT5 UP TO 3 KVA	SUGXT-1K3K	SUGXT-1K3KRMV
External battery cabinet (36V or 48V or 72V)	SUGXT-EXTBTCB	SUGXT-EXTBTCBMV

Power Emergency Services

5-Year on-site emergency coverage - only	Standard	With Life services
Equipment model / type	Part number	Part number
Vertiv™ Liebert® GXT5 UP TO 1 KVA	PEPGXT-1K5YR	PEPGXT-1KLF
Vertiv Liebert GXT5 1.5 kVA	PEPGXT-15005YR	PEPGXT-1500LF
Vertiv Liebert GXT5 2.0 kVA	PEPGXT-20005YR	PEPGXT-2000LF
Vertiv Liebert GXT5 3.0 kVA	PEPGXT-30005YR	PEPGXT-3000LF
External battery cabinet 36V	PEPGXT-36VBAT5YR	N/A
External battery cabinet 48V	PEPGXT-48VBAT5YR	N/A
External battery cabinet 72V	PEPGXT-72VBAT5YR	N/A

Power Assurance Package - summary

- Includes all below "Power Start-up Services" and "Power Emergency Services" support
- One Preventative Maintenance visit after 3rd year (5-10kVA UPS only)

Power Startup Services - summary

- Installation includes mounting and start-up of new UPS or EBC (excludes hard-wired applications)
- Services performed by Vertiv factory trained technician
- Services performed 7 X 24, excluding national holidays within the 48 contiguous states and Hawaii
- Removal and disposal of existing UPS or EBC equipment, if selected

Power Emergency Services - summary

- On site service support
- Full-service five (5) year contract term commencing upon the start-up date
- 100% parts coverage, including internal batteries, POD and web card
- 100% labor and travel coverage 7 days/week, 24 hours/day
- 24-Hour Customer Resolution Center via 1-800-LIEBERT
- Access to Customer Services Network portal

Vertiv™ Life™ Services includes above plus:

- Continuous monitoring, expert analysis, and proactive response

Note: Vertiv Life Services requires an RDU120 card, which is included on all 5000VA to 10000VA models.

Please refer to the Scopes of Work for full and additional details.



Vertiv.com | Vertiv Headquarters, 505 N Cleveland Ave, Westerville, OH 43082, USA

© 2026 Vertiv Group Corp. All rights reserved. Vertiv™ and the Vertiv logo are trademarks or registered trademarks of Vertiv Group Corp. All other names and logos referred to are trade names, trademarks or registered trademarks of their respective owners. While every precaution has been taken to ensure accuracy and completeness here, Vertiv Group Corp. assumes no responsibility, and disclaims all liability, for damages resulting from use of this information or for any errors or omissions. Specifications, rebates and other promotional offers are subject to change at Vertiv's sole discretion upon notice.