



Liebert®CRV Row Based Cooling System

Installer/User Guide

600 mm and 300 mm Wide

The information contained in this document is subject to change without notice and may not be suitable for all applications. While every precaution has been taken to ensure the accuracy and completeness of this document, Vertiv assumes no responsibility and disclaims all liability for damages result from use of this information or for any errors or omissions.

Vertiv recommends installing a monitored fluid detection system that is wired to activate the automatic closure of field-installed coolant fluid supply and return shut off valves, where applicable, to reduce the amount of coolant fluid leakage and consequential equipment and building damage. Refer to local regulations and building codes relating to the application, installation, and operation of this product. The consulting engineer, installer, and/or end user is responsible for compliance with all applicable laws and regulations relation to the application, installation, and operation of this product.

The products covered by this instruction manual are manufactured and/or sold by Vertiv. This document is the property of Vertiv and contains confidential and proprietary information owned by Vertiv. Any copying, use, or disclosure of it without the written permission of Vertiv is strictly prohibited.

Names of companies and products are trademarks or registered trademarks of the respective companies. Any questions regarding usage of trademark names should be directed to the original manufacturer.

Technical Support Site

If you encounter any installation or operational issues with your product, check the pertinent section of this manual to see if the issue can be resolved by following outlined procedures.

Visit <https://www.vertiv.com/en-us/support/> for additional assistance.

TABLE OF CONTENTS

1 Important Safety Instructions	1
2 Nomenclature and Components	7
2.1 Model Number Nomenclature	7
2.2 Component Location	7
2.3 Cooling Configurations and Liebert® CRV Overview	8
3 Pre-installation Preparation and Guidelines	9
3.1 Planning Dimensions	9
3.2 Unit Weights	9
4 Equipment Inspection and Handling	11
4.1 Packaging Material	12
4.2 Handling the Unit while Packaged	12
4.3 Unpacking the Export Shipped 600 mm (24 in.) Unit	12
4.4 Unpacking the Domestic Shipped 600 mm (24 in.) Unit	13
4.5 Removing 600 mm (24 in.) Units from the Pallet	14
4.6 Unpacking the Export Shipped 300 mm (24 in.) Unit	16
4.7 Unpacking the Domestic Shipped 300 mm (12 in.) Unit	17
4.8 Removing 300 mm (12 in.) Units from the Pallet	18
5 Installing in Enclosure Row	21
5.1 Adjusting Base Supports/Leveling Feet	21
5.2 Optional Tie Down Brackets for 300 mm (12 in.) Units	23
5.2.1 What's Included	23
5.2.2 Tools Required	24
5.2.3 Installing Tie Down Brackets on 300 mm (12 in.) and on Cabinets of Different Heights	24
5.2.4 Installing Tie Down Brackets on 300 mm (12 in.) and on Cabinets of the Same Height	26
6 Piping and Refrigerant Requirements	27
6.1 Drain and Humidifier Fluid Piping	28
6.1.1 Humidifier Water Supply Line Requirements	28
6.1.2 Condensate Pump Drain Line Requirements	29
6.1.3 Condensate Pump Drain Piping for 300 mm (12 in.) Models	30
6.1.4 Field Installed, Gravity Fed Drain Line Requirements	36
6.2 Refrigerant Piping and Charging	41
6.2.1 Refrigerant Piping Guidelines for Air Cooled Systems	42
6.3 Piping Guidelines for Liebert® MC Condensers	43
6.3.1 Piping Layout and Condenser Positioning	44
6.3.2 Top or Bottom Connection for Refrigerant Piping on Air Cooled Units	45
6.3.3 Refrigerant Line Sizes and Equivalent Lengths	46
6.3.4 Refrigerant Charge Requirements for Air Cooled Systems	48
6.3.5 Additional Oil Requirements for Digital Scroll Compressors	50
6.3.6 Evacuation, Leak Testing, and Charging Air Cooled Systems without Receivers	52

6.3.7 Evacuation, Leak Testing, and Charging Air Cooled Systems with Liebert® Lee-Temp Flooded Condenser Head Pressure Control System	58
6.3.8 Superheat and Refrigerant Charge Optimization	60
6.4 Water/Glycol Loop Piping Guidelines	62
6.4.1 Glycol Mixture	64
6.4.2 Water/Glycol Cooled Piping Connections	64
6.4.3 Leak Checking for Unit and Field Installed Piping	66
6.5 Chilled Water Loop Piping	66
7 Electrical Connections	69
7.1 Power Supply Cable Connection Guidelines	69
7.2 Wiring Connection Guidelines	70
7.3 Electrical Field Connections Descriptions	70
7.3.1 Locating the Serial Tags and Removing the Electrical Panel on 600 mm (24 in.) Units	70
7.3.2 Cable Entry Points on 600 mm (24 in.) Units	73
7.3.3 Protective Features of Electrical Heaters—600-mm (24-in.) Units	74
7.3.4 Accessing the Electrical Panel on 300 mm (12 in) Units	74
7.3.5 Releasing the Electric Panel Lock	75
7.4 Protective Features of the Electronically Commutated (EC) Fans—All Models	76
8 Humidifier 600 mm (24 in.) Units Only	79
8.1 Principal of Operation	79
8.2 Connecting Water Supply to the Humidifier	80
8.3 Humidifier Startup and Operation	81
8.3.1 Low Water Conductivity	81
8.4 Humidifier Canister Replacement	82
8.4.1 Removing the Old Canister	82
8.4.2 Mandatory Cleaning of the Drain Valve	83
8.4.3 Installing the New Canister	84
8.5 Humidifier Maintenance during Extended Shutdown	85
8.5.1 Humidifier Troubleshooting	85
8.5.2 Humidifier Troubleshooting Steps	87
9 Startup	89
9.1 Checks to Perform after Startup	90
9.2 Automatic Restart	91
9.3 Chilled Water Valve— All Chilled Water Models	92
9.4 Adjust Baffles to Direct Air Properly	93
9.4.1 Adjusting Baffles—600 mm (24 in.)	94
9.4.2 Adjusting Blocker Plate—600 mm (12 in.)	95
9.4.3 Adjusting Baffles—300 mm (12 in.)	95
10 Troubleshooting	97
11 Maintenance	101
11.1 Safety Instructions	101
11.2 Facility Fluid and Piping Maintenance for Water and Glycol Systems	102

11.3 Glycol Solution Maintenance	102
11.4 Spare Parts	102
11.5 Maintenance Schedule	102
11.6 Thermostatic Expansion Valve (TXV) Maintenance	104
11.6.1 Determining Suction Superheat	104
11.6.2 Adjusting Superheat Setting with the TXV	105
11.7 Compressor Maintenance	105
11.7.1 Compressor Oil	105
11.7.2 Replacement Compressors	105
11.7.3 Rotalock Valve on Digital Scroll Compressors	106
11.7.4 Unloading Solenoid(s) on a Digital Scroll Compressor	106
11.7.5 Compressor Electrical Failure (Motor Burnout)	107
11.7.6 Replacing a Compressor with Electrical Failure (Motor Burnout)	107
11.7.7 Compressor Mechanical Failure	107
11.7.8 Replacing a Compressor with Mechanical Failure	108
11.8 Inspect and Replace the Air Filters—600 mm (24 in.) Models	109
11.9 Inspect and Replace the Air Filters—300 mm (12 in.) Models	111
11.10 Condensate Drain and Condensate Pump System Maintenance	112
11.10.1 Condensate Drain	112
11.10.2 Condensate Pump, Dual Float	112
11.11 Air-Cooled Condenser and Drycooler Maintenance	113
11.12 Electric Reheat Maintenance	113
11.13 Fan Replacement	114
11.13.1 Replacing a Fan in 600 mm (24 in.) Models	114
11.13.2 Replacing a Fan in 300 mm (12 in.) Models	115
11.14 Considerations when Dismantling the Unit	116
12 Preventive Maintenance Worksheet	119
Appendices	125
Appendix A: Technical Support and Contacts	125
Appendix B: Model Number Nomenclature Detail	127
Appendix C: Submittal Drawings	131

1 Important Safety Instructions

SAVE THESE INSTRUCTIONS

This manual contains important safety instructions that should be followed during the installation and maintenance of the Liebert® CRV. Read this manual thoroughly before attempting to install or operate this unit.

Only qualified personnel should move, install or service this equipment.

Adhere to all warnings, cautions, notices and installation, operating and safety instructions on the unit and in this manual. Follow all installation, operation and maintenance instructions and all applicable national and local building, electrical and plumbing codes.

Any operation that requires opening doors or equipment panels must be carried out only by properly-trained and qualified personnel.

To identify the unit model and serial number for assistance or spare parts, locate the identification label on the unit. The label is inside the door on 600 mm (24 in.) units and at the electrical box on 300 mm (12 in.) units.

A warning label on the front and back panels reminds users that:

- The Liebert® CRV restarts automatically
- The main switch must be opened before opening the internal compartments for any operation.



WARNING! Arc flash and electric shock hazard. Open all local and remote electric power-supply disconnect switches, verify with a voltmeter that power is Off and wear appropriate, OSHA-approved personal protective equipment (PPE) per NFPA 70E before working within the electric control enclosure. Failure to comply can cause serious injury or death. Customer must provide earth ground to unit, per NEC, CEC and local codes, as applicable. Before proceeding with installation, read all instructions, verify that all the parts are included and check the nameplate to be sure the voltage matches available utility power. The Liebert® controller does not isolate power from the unit, even in the “Unit Off” mode. Some internal components require and receive power even during the “Unit Off” mode of the controller. The only way to ensure that there is NO voltage inside the unit is to install and open a remote disconnect switch. Refer to unit electrical schematic. Follow all local codes.

Installation, service, and maintenance work must be performed only by properly trained and qualified personnel and in accordance with applicable regulations and manufacturers’ specifications. Opening or removing the covers to any equipment may expose personnel to lethal voltages within the unit even when it is apparently not operating and the input wiring is disconnected from the electrical source.



WARNING! Risk of over pressurization of the refrigeration system. Can cause explosive discharge of high pressure refrigerant, loss of refrigerant, environmental pollution, equipment damage, injury, or death. This unit contains fluids and gases under high pressure. Use extreme caution when charging the refrigerant system. Do not pressurize the system higher than the design pressure marked on the unit's nameplate.



WARNING! Risk of contact with high speed rotating fan blades. Can cause serious injury or death. Open all local and remote electric power-supply disconnect switches, verify with a voltmeter that power is off, and verify that all fan blades have stopped rotating before working in the unit cabinet or on the fan assembly. Fan motor controls can maintain an electric charge for 10 minutes after power is disconnected. If control voltage is applied, the fan motor can restart without warning after a power failure.



WARNING! Risk of top-heavy unit falling over. Improper handling can cause equipment damage, injury or death. Read all of the following instructions and verify that all lifting and moving equipment is rated for the weight of the unit before attempting to move, lift, remove packaging from or prepare the unit for installation. Unit weights are specified in **Table 3.2** on page 10 .



WARNING! Risk of unsecured unit rolling off pallet. Can cause equipment damage, injury or death. The unit is on casters. Ensure that the pallet is located on a flat surface before loosening the hardware securing the to its shipping pallet.



WARNING! Risk of hair, clothing and jewelry entanglement with high speed rotating fan blades. Can cause equipment damage, serious injury or death. Keep hair, jewelry and loose clothing secured and away from rotating fan blades during unit operation.



WARNING! Risk of contact with extremely hot and/or cold surfaces. Can cause injury. Verify that all components have reached a temperature that is safe for human contact or wear appropriate, OSHA-approved PPE before working within the electric connection enclosures or unit cabinet. Perform maintenance only when the system is de-energized and component temperatures have become safe for human contact.



WARNING! Risk of improper wiring, piping, moving, lifting and handling. Can cause equipment damage, serious injury or death. Installation and service of this equipment should be done only by qualified personnel who have been specially trained in the installation of air conditioning equipment and who are wearing appropriate, OSHA-approved PPE.



WARNING! Risk of improper wire sizing/rating and loose electrical connections. Can cause overheated wire and electrical connection terminals resulting in smoke, fire, equipment and building damage, injury or death. Use correctly sized copper wire only and verify that all electrical connections are tight before turning power On. Check all electrical connections periodically and tighten as necessary.



WARNING! Risk of humidifier canister meltdown, smoke and fire. Can cause fire suppression system activation, fire and smoke alarm activation, building evacuation, dispatching of fire and rescue equipment and personnel and water leaks resulting in expensive equipment or building damage, injury or death. Check steam generating humidifier electrode plugs to ensure that they are pressed firmly onto pins. Loose connections will cause overheating of cylinder and plugs.



CAUTION: Risk of contact with sharp edges, splinters, and exposed fasteners. Can cause injury. Only properly trained and qualified personnel wearing appropriate, OSHA-approved PPE should attempt to move, lift, remove packaging from or prepare the unit for installation.



CAUTION: Risk of improper moving, lifting and handling. Can cause equipment damage or injury. Only properly trained and qualified personnel should work on this equipment. Condenser fan modules weigh in excess of 125 lb (56.7 kg). Use proper lifting techniques and wear appropriate, OSHA-approved PPE to avoid injury and dropping the fan module during removal. Equipment used in handling/lifting, and/or installing the fan assembly must meet OSHA requirements. Use handling/lifting equipment rated for the weight of the fan assembly. Use ladders rated for the weight of the fan assembly and technicians if used during installation. Refer to handling/lifting, and/or installation equipment operating manual for manufacturer's safety requirements and operating procedures.



CAUTION: Risk of exposure to harmful noise levels. Can cause hearing injury or loss. Depending on the installation and operating conditions, a sound pressure level greater than 70 dB(A) may arise. Take appropriate technical safety measures. Operating personnel must wear appropriate, OSHA-approved PPE and observe all appropriate hearing protection safety requirements.



CAUTION: Risk of excessive refrigerant line pressure. Can cause tubing and component rupture resulting in equipment damage and personal injury. Do not close off the refrigerant line isolation valve for repairs unless a pressure-relief valve is field installed in the line between the isolation valve and the check valve. The pressure relief valve must be rated 5% to 10% higher than the system design pressure. An increase in ambient temperature can cause the pressure of the isolated refrigerant to rise and exceed the system design pressure rating (marked on the unit nameplate).

NOTICE

Risk of improper power supply connection. Can cause equipment damage and loss of warranty coverage. Prior to connecting any equipment to a main or alternate power source (for example: backup generator systems) for startup, commissioning, testing, or normal operation, ensure that these sources are correctly adjusted to the nameplate voltage and frequency of all equipment to be connected.

NOTICE

Risk of oil contamination with water. Can cause equipment damage.

Liebert® CRV systems require the use of POE (polyolester) oil. POE oil absorbs water at a much faster rate when exposed to air than previously used oils. Because water is the enemy of a reliable refrigeration system, extreme care must be used when opening systems during installation or service. If water is absorbed into the POE oil, it will not be easily removed and will not be removed through the normal evacuation process. If the oil is too wet, it may require an oil change. POE oils also have a property that makes them act as a solvent in a refrigeration system. Maintaining system cleanliness is extremely important because the oil will tend to bring any foreign matter back to the compressor.

NOTICE

Risk of improper refrigerant charging. Can cause equipment damage.

Refrigerant charge must be weighed into air-cooled compressorized systems before they are started. Starting scroll and digital scroll compressors without proper refrigerant charging can cause the compressors to operate at less than 5°F (-15°C) evaporator temperature and at less than 20 psig (138 kPa). Operation for extended periods at less than 20 psig (138 kPa) can cause premature compressor failure.

NOTICE

Risk of clogged or leaking drain lines and leaking water supply lines. Can cause equipment and building damage.

This unit requires a water drain connection. Drain lines must be inspected at startup and periodically, and maintenance must be performed to ensure that drain water runs freely through the drain system and that lines are clear and free of obstructions and in good condition with no visible sign of damage or leaks. This unit may also require an external water supply to operate.

Improper installation, application and service practices can result in water leakage from the unit. Water leakage can result in catastrophic and expensive building and equipment damage and loss of critical data center equipment.

Do not locate unit directly above any equipment that could sustain water damage.

We recommend installing a monitored fluid detection system to immediately discover and report coolant fluid system and condensate drain line leaks.

NOTICE

Risk of piping system corrosion and freezing fluids. Can cause leaks resulting in equipment and very expensive building damage. Cooling coils, heat exchangers and piping systems are at high risk of freezing and premature corrosion. Fluids in these systems must contain the proper antifreeze and inhibitors to prevent freezing and premature coil, heat exchanger and piping corrosion. The water or water/glycol solution must be analyzed by a competent local water treatment specialist before start up to establish the inhibitor and antifreeze solution requirement and at regularly scheduled intervals throughout the life of the system to determine the pattern of inhibitor depletion.

The complexity of water/glycol solution condition problems and the variations of required treatment programs make it extremely important to obtain the advice of a competent and experienced water treatment specialist and follow a regularly scheduled coolant fluid system maintenance program.

Water chemistry varies greatly by location, as do the required additives, called inhibitors, that reduce the corrosive effect of the fluids on the piping systems and components. The chemistry of the water used must be considered, because water from some sources may contain corrosive elements that reduce the effectiveness of the inhibited formulation. Sediment deposits prevent the formation of a protective oxide layer on the inside of the coolant system components and piping. The water/coolant fluid must be treated and circulating through the system continuously to prevent the buildup of sediment deposits and or growth of sulfate reducing bacteria.

Proper inhibitor maintenance must be performed in order to prevent corrosion of the system. Consult glycol manufacturer for testing and maintenance of inhibitors.

Commercial ethylene glycol, when pure, is generally less corrosive to the common metals of construction than water itself. It will, however, assume the corrosivity of the water from which it is prepared and may become increasingly corrosive with use if not properly inhibited.

We recommend installing a monitored fluid detection system that is wired to activate the automatic closure of field installed coolant fluid supply and return shutoff valves to reduce the amount of coolant-fluid leakage and consequential equipment and building damage. The shutoff valves must be sized to close off against the maximum coolant fluid system pressure in case of a catastrophic fluid leak.

NOTICE

Risk of frozen pipes and corrosion from improper coolant mixture. Can cause water leaks resulting in equipment and building damage.

When the cooling unit or piping may be exposed to freezing temperatures, charge the system with the proper percentage of glycol and water for the coldest design ambient temperature. Automotive antifreeze is unacceptable and must NOT be used in any glycol fluid system. Use only HVAC glycol solution that meets the requirements of recommended industry practices.

NOTICE

Risk of no flow condition. Can cause equipment damage.

Do not leave the water/coolant fluid supply circuit in a no flow condition. Idle fluid allows the collection of sediment that prevents the formation of a protective oxide layer on the inside of tubes. Keep unit switched On and water/coolant fluid-supply circuit system operating continuously.

NOTICE

Risk of doorway/hallway interference. Can cause unit and/or structure damage. The unit may be too large to fit through a doorway or hallway while on the skid. Measure the unit and passageway dimensions, and refer to the installation plans prior to moving the unit to verify clearances.

NOTICE

Risk of improper water supply. Can reduce humidifier efficiency or obstruct humidifier plumbing.

Do not use completely demineralized water with this unit. The water must contain minerals for the electrode principle to work.

Do not use a hot water source. It will cause deposits that will eventually block the fill valve opening.

NOTICE

Risk of water backing up in the drain line. Leaking and overflowing water can cause equipment and building damage.

Do not install an external trap in the drain line. This line already has a factory installed trap inside the cabinet (except for 300 mm (12 in.)) Chilled water models). Installation of a second trap will prevent drain water flow and will cause the water to overflow the drain pan.

This line may contain boiling water. Use copper or other material that is rated for handling boiling water for the drain line. Sagging condensate drain lines may inadvertently create an external trap.

NOTICE

Risk of doorway/hallway interference. Can cause unit and/or structure damage. The unit may be too large to fit through a doorway or hallway while on the skid. Measure the unit and passageway dimensions, and refer to the installation plans prior to moving the unit to verify clearances.

NOTICE

Risk of damage from forklift. Can cause unit damage. Keep tines of the forklift level and at a height suitable to fit below the skid and/or unit to prevent exterior and/or underside damage.

NOTICE

Risk of improper storage. Can cause unit damage.

Keep the unit upright, indoors and protected from dampness, freezing temperatures and contact damage.

NOTICE

Risk of release of hazardous substances into the environment. Can cause environmental pollution and violation of environmental regulations.

The Liebert® CRV contains substances and components hazardous for the environment (electronic components, refrigerating gases and oils). At the end of its useful life, the Liebert® CRV must be dismantled by specialized refrigerating technicians. The unit must be delivered to suitable centers specializing in the collection and disposal of equipment containing hazardous substances.

NOTICE

Condenser fans should be operated manually if they have not run for an extended time in an outdoor environment. Before enabling the condenser for normal cooling operation fans should be run at full speed for at least 3 hours once a month to move the bearings and allow any condensate that may have ingressed to evaporate.

Condenser firmware release 1.06.045 and later include settings to operate condenser fans if they have been inactive for more than 30 days.

NOTE: The Liebert indoor cooling unit has a factory installed high pressure safety switch in the high side refrigerant circuit. Consult local building codes to determine whether the Liebert® MC Condensers without receivers will require field provided pressure relief devices such as a fusible plug. A pressure relief valve is provided with Liebert® Lee-Temp receivers.

Agency Listed

Standard 60 Hz units are CSA Certified to the harmonized U.S. and Canadian product safety standard CSA C22.2 No 236/UL 1995 for "Heating and Cooling Equipment" and are marked with the CSA c-us logo.



2 Nomenclature and Components

This section describes the model number for Liebert® CRV units and components.

2.1 Model Number Nomenclature

The tables describe the 25 digit configuration number. The 14 digit model number consists of the first 10 digits and last 4 digits of the configuration number.

For the full description of configuration and model number refer to [Model Number Nomenclature Detail](#) on page 127.

Model Number Digits 1 to 10										Model Details											Model Number Digits 11 to 14			
1	2	3	4	5	6	7	8	9	10	11	12	13	14	15	16	17	18	19	20	21	22	23	24	25
C	R	0	2	0	R	A	1	C	7	S	H	1	8	1	1	E	L	1	0	P	A	—	—	—

Digits 1-2 - Unit Family	Digit 14 - Air Filter
Digits 3-5 - Nominal Capacity, kW	Digit 15 - Water/Glycol Valve Type
Digit 6 - Row-Based, Unit Depth	Digit 16 - Enclosure
Digit 7 - System Type	Digit 17 - High Voltage Options
Digit 8 - Fan Type	Digit 18 - Option Package
Digit 9 - Power Supply	Digit 19 - Liebert® IntelliSlot™ Housing
Digit 10 - Cooling System	Digit 20 - Future Options
Digit 11 - Humidifier	Digit 21 - Packaging With Ramp
Digit 12 - Control System	Digit 22 - Special Features
Digit 13 - Reheat	Digits 23-25 - Factory Configuration Number

2.2 Component Location

The unit component locations are described in the submittal documents included in the [Submittal Drawings](#) on page 131.

The following table lists the relevant documents by number and title.

Table 2.1 Component Location Drawings

Document Number	Title
DPN003738	Component Location Diagram, 600mm (24in.) Models
DPN003583	Component Location Diagram, 300mm (12in.) Air Cooled Models
DPN003585	Component Location, 300mm (12in.) Water Glycol Cooled Models
DPN003584	Component Location, 300mm (12in.) Chilled Water Models

2.3 Cooling Configurations and Liebert® CRV Overview

The Liebert®CRV is a precision cooling unit available in compressorized (air, water, or glycol cooled) and chilled water configurations to be installed within a row of high density computing racks in a “hot aisle-cold aisle” configuration.

Air enters the rear of the CRV from the hot aisle, is filtered, cooled and conditioned, then discharged into the cold aisle. The CRV provides all the necessary functions of a standard Thermal Management unit, including cooling, heating, humidification, dehumidification, air filtration, condensate management, temperature control, alarm monitoring and data communication. (The 300 mm [12 in.] models do not provide heating, humidification or dehumidification.) The CRV is optimized for maximum cooling capacity in a minimal footprint.

The Liebert® CRV 300 series and 600 series Thermal Management units are meant for location within a row of heat generating IT equipment racks.

The extremely energy efficient components of the CRV are managed by the Liebert® iCOM™ control system. The iCOM control monitors the environment in real time with rack inlet sensors on the cooled by the in-row CRV. The information gathered allows optimization of performance and energy efficiency.

All operations and sensor data can be reported remotely via a variety of communication protocols, providing a built-in, rack-temperature monitoring system.

The supply-air baffle directs the air leaving the CRV to the racks, maximizing its effectiveness, reducing the chance for hot spots, and improving overall system efficiency. The angle and spacing of the baffle vanes series are optimized through CFD modeling, laboratory testing and real world installations.

All service and maintenance is performed through the front and rear of the unit, including all component replacement. All piping and electrical connections are made through the top or bottom of the unit.

Table 2.2 CRV Configurations

Series	Width	Cooling Type	Nominal Cooling Capacity, kW	Input Power 60 Hz
600	24 in. (600 mm)	Air	20	208 V/3 ph 460 V/3 ph 460 V/3 ph
		Water/Glycol		
		Air	35	
		Water/Glycol		
		Chilled Water	40	
		50	460 V/3 ph	
300	12 in. (300 mm)	Air	19	208-230 V/3 ph 460 V/3 ph-Wye
		Chilled Water	32	208-230 V/1 ph 208-230 V/3 ph 460 V/3 ph-Wye 120 V/1 ph
		Water/Glycol	19	208-230 V/3 ph 460 V/3 ph-Wye

3 Pre-installation Preparation and Guidelines

NOTE: Before installing unit, determine whether any building alterations are required to run piping and wiring. Follow all unit dimensional drawings and refer to the submittal engineering dimensional drawings of individual units for proper clearances.

Refer to [Model Number Nomenclature](#) on page 7 and the appropriate submittal drawings, to determine the type of system being installed and anticipate building alterations and piping needed.

The unit dimensions, pipe connection locations, and piping schematics are described in the submittal documents included in the [Submittal Drawings](#) on page 131.

- Verify that the floor is level, solid and sufficient to support the unit. See [Unit Weights](#) below for unit weights.
- Confirm that the room is properly insulated and has a sealed vapor barrier.
- For proper humidity control, keep outside or fresh air to an absolute minimum (less than 5% of total air circulated in the room).
- Do not install a Liebert® CRV in an alcove or at the end of a long, narrow room.
- Install the units as close as possible to the largest heat load.
- Allow at least the minimum recommended clearances for maintenance and service. See the appropriate submittal drawings for dimensions.
- We recommend installing an under floor leak detection system. Contact your Vertiv representative for information.

3.1 Planning Dimensions

The unit, floor stand, and plenum dimensions are described in the submittal documents included in the [Submittal Drawings](#) on page 131.

The following table lists the relevant documents by number and title.

Table 3.1 Dimension Planning Drawings

Document Number	Title
DPN001791	Cabinet Dimensional Data 600 mm (24 in.) Models
DPN002807	Cabinet Dimensional Data 300 mm (12 in.) Models

3.2 Unit Weights

Table 3.2 Shipping Weights

Model No.	Domestic Packaging, lb (kg)			Export Packaging, lb (kg)		
	Air	Water/Glycol	Chilled Water	Air	Water/Glycol	Chilled Water
CR019	649 (294)	687 (311)	—	721 (327)	782 (355)	—
CR032	—	—	560 (254.0)	—	—	683 (309.8)
CR020	846 (384)	879 (399)	—	953 (432)	986 (447)	—

Table 3.2 Shipping Weights (continued)

Model No.	Domestic Packaging, lb (kg)			Export Packaging, lb (kg)		
	Air	Water/Glycol	Chilled Water	Air	Water/Glycol	Chilled Water
CR035	912 (414)	956 (434)	—	1019 (462)	1063 (482)	—
CR040	—	—	835 (379)	—	—	942 (427)
CR050	—	—	862 (391)	—	—	970 (440)

4 Equipment Inspection and Handling



WARNING! Risk of top-heavy unit falling over. Improper handling can cause equipment damage, injury or death. Read all of the following instructions and verify that all lifting and moving equipment is rated for the weight of the unit before attempting to move, lift, remove packaging from or prepare the unit for installation. Unit weights are specified in **Table 3.2** on page 10 .



WARNING! Risk of contact with sharp edges, splinters, and exposed fasteners. Can cause injury. Only properly trained and qualified personnel wearing appropriate, OSHA-approved PPE should attempt to move, lift, remove packaging from or prepare the unit for installation.

NOTICE

Risk of passageway interference. Can cause unit and/or structure damage. The unit may be too large to fit through a passageway while on or off the skid. Measure the unit and passageway dimensions, and refer to the installation plans prior to moving the unit to verify clearances.

NOTICE

Risk of damage from forklift. Can cause unit damage. Keep tines of the forklift level and at a height suitable to fit below the skid and/or unit to prevent exterior and/or underside damage.

NOTICE

Risk of improper storage. Can cause unit damage. Keep the unit upright, indoors and protected from dampness, freezing temperatures and contact damage.

Upon arrival of the unit and before unpacking:

- Verify that the labeled equipment matches the bill of lading.
- Carefully inspect all items for visible or concealed damage.
- Report damage immediately to the carrier and file a damage claim with a copy sent to Vertiv or to your sales representative.
- For initial access, use a 7/32 in. Allen wrench for panel removal.

Equipment Recommended for Handling the Unit:

- Forklift
- Pallet jack
- Piano jacks
- Slings
- Spreader bars

4.1 Packaging Material



All material used to package this unit is recyclable. Please save for future use or dispose of the material appropriately.

4.2 Handling the Unit while Packaged

Transport the unit with a forklift or pallet jack.

When using a forklift or pallet jack:

- Make sure that the forks (if adjustable) are spread to the widest allowable distance that will fit under the skid.
- Make sure the fork length is suitable for the skid length. Skid length is 60 in (1524 mm)
- When moving the packaged unit, do not lift the unit any higher than 2 to 4 in. (51 to 102 mm). All personnel except those moving the unit must be kept 12 ft (3.7 m) or more from the unit while it is being moved.
- If the unit must be lifted higher than 4 in. (102 mm), all personnel not directly involved in moving the unit must be 20 ft (5 m) or farther from the unit.

4.3 Unpacking the Export Shipped 600 mm (24 in.) Unit

1. Remove the metal clips (12 places typical) that secure the top panel of the crate to the side panels, see **Figure 4.1** on the facing page .
2. Use a Phillips head screw driver to remove all the wood screws (34 places typical) that secure the side panels together and to the pallet, see **Figure 4.1** on the facing page .
3. To remove the remaining packaging, start with Step 1, of [Unpacking the Domestic Shipped 600 mm \(24 in.\) Unit](#) on the facing page .

Figure 4.1 Metal Clips and Wood Screws on Crate

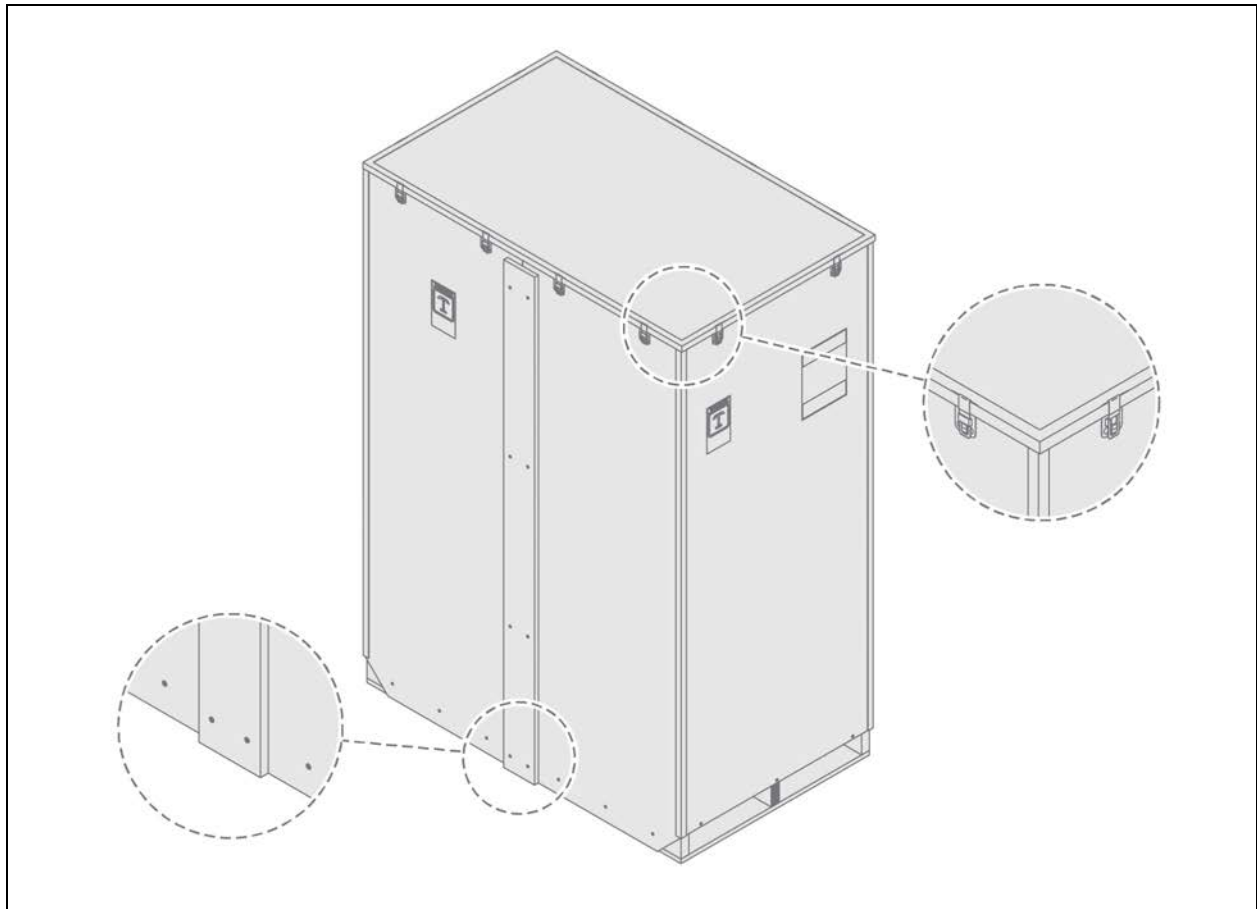

Item	Description
1	Metal clips, typical 12 places
2	Wood screws, minimum 34 places

4.4 Unpacking the Domestic Shipped 600 mm (24 in.) Unit

1. Use a 9/16 in. socket drive or wrench to remove the lag screws (4 places typical) that secure the ramp to the pallet, see **Figure 4.2** on the next page. Set the ramps aside for use later when preparing move the unit from the pallet.
2. Remove the exterior packaging from around the unit

NOTE: The bag may remain in place to protect from dust and to protect the unit panels, or it may be removed for immediate installation.

3. Remove the bag from the unit when ready to move off the pallet and install the unit. See [Removing 600 mm \(24 in.\) Units from the Pallet](#) on the next page.

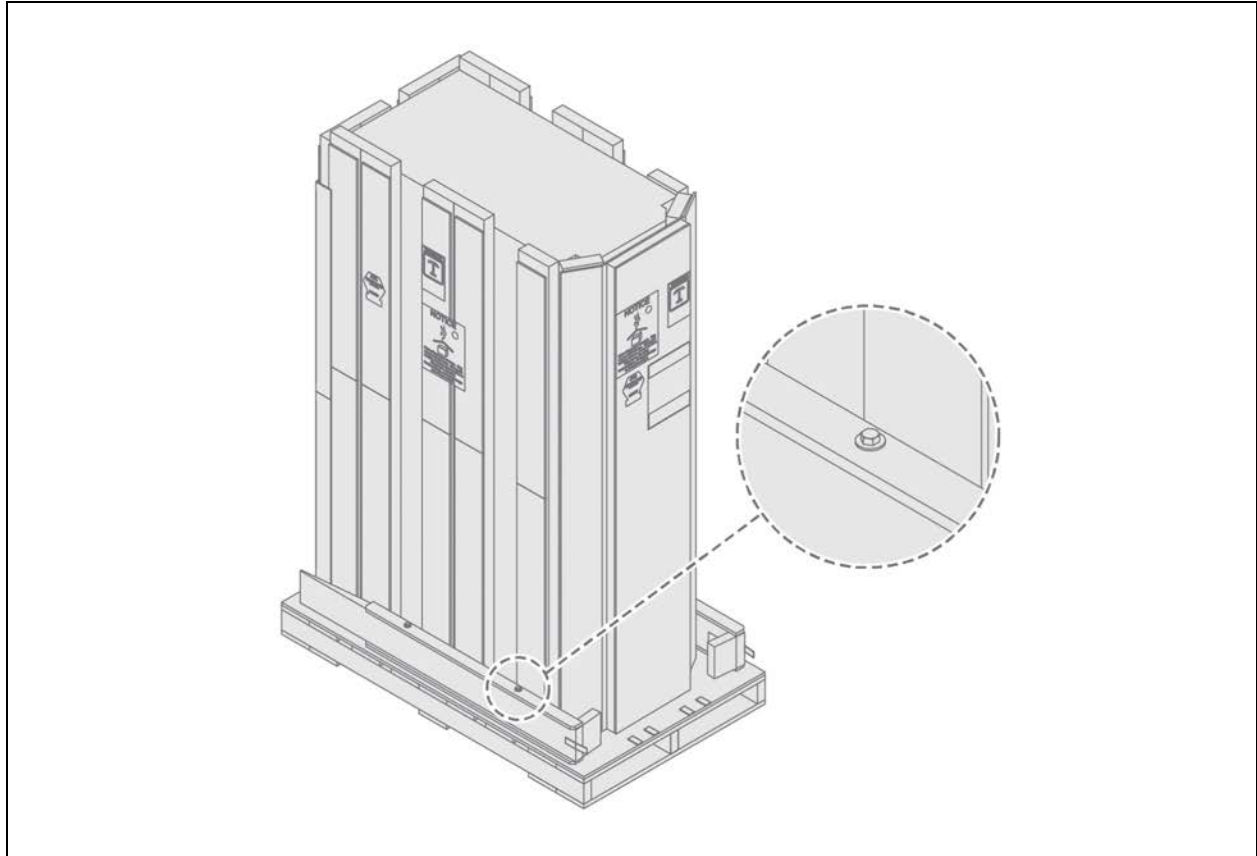
Figure 4.2 Lag Screws that Secure Ramps

4.5 Removing 600 mm (24 in.) Units from the Pallet

1. Remove front panel, see **Figure 4.3** on the facing page
 - Open the top panel door (with controller display).
 - Using a 8 mm hex head or T30 Torx screwdriver, remove the screws securing the bottom front panel assembly, and set aside until instructed to re attach.
 - Close and latch the top panel door.
2. Lower the 4 leveling feet to touch the pallet deck as shown in **Figure 4.3** on the facing page . Open the rear, hinged door to access the rear leveling feet.
3. Using a 13 mm socket-drive or wrench, remove the screws that secure the shipping brackets to the side of the unit, 3 each side, see **Figure 4.3** on the facing page .
4. Using a 9/16 in. socket drive or wrench, remove the lag screws that secure the shipping brackets to the pallet, 4 each side, see **Figure 4.3** on the facing page .
5. Adjust the 4 leveling feet equally, to raise the unit off the shipping blocks, and remove the blocks, see **Figure 4.3** on the facing page .

Figure 4.3 Preparing to Attach Ramps

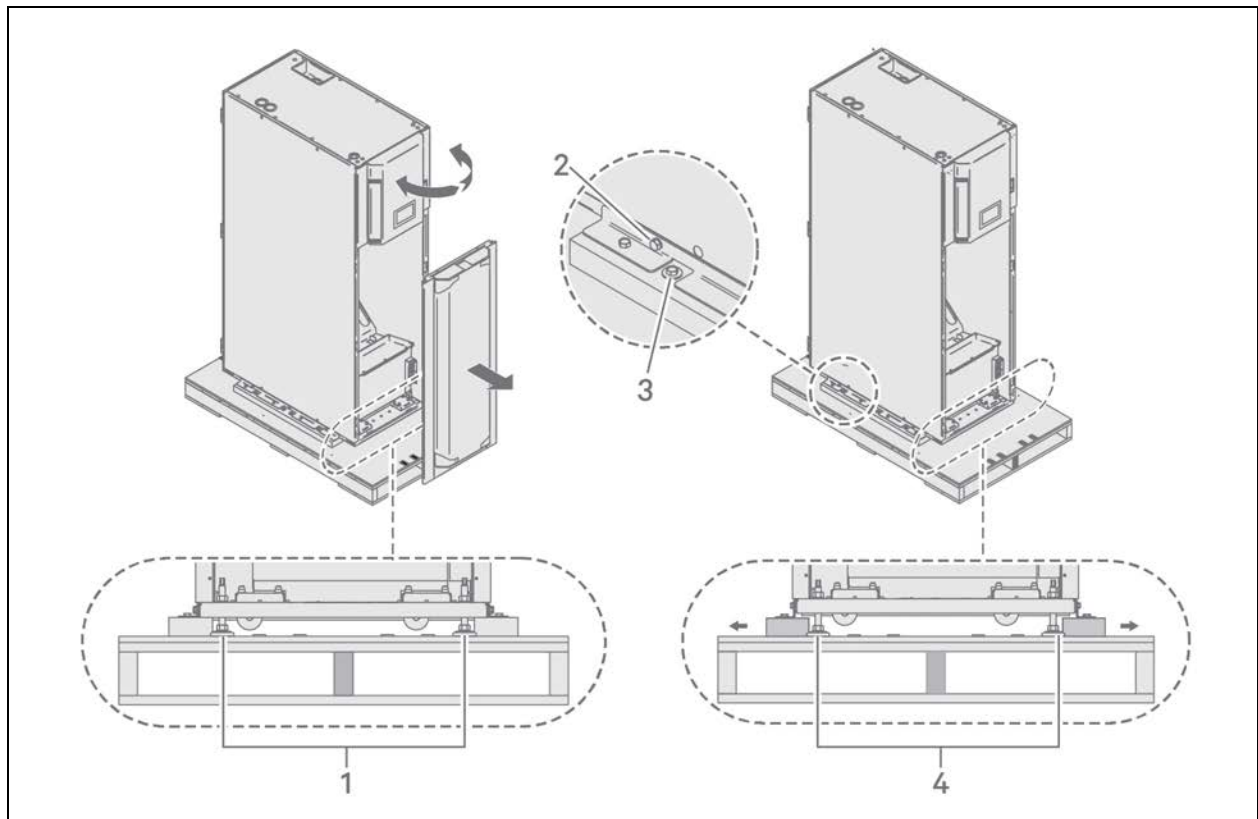

Item	Description
1	Leveling feet touching pallet, front view
2	13 mm hex head screw, 3 each side
3	9/16-in. hex head screw, 4 each side
4	Leveling feet raise unit off shipping blocks, front view

6. Locate the ramps and attach to the pallet using the hook and loop strips, see **Figure 4.4** on the next page, for placement of the strips.



WARNING! Risk of unsecured unit rolling off pallet. Can cause equipment damage, injury or death. The unit is on casters. Ensure that the pallet is located on a flat surface before loosening the hardware securing the to its shipping pallet.

7. Adjust the 4 leveling feet equally until casters make contact with the pallets, then continue to raise all the feet to the full up position, see **Figure 4.4** on the next page.

IMPORTANT! Two or more properly trained and qualified personnel are required to move the unit to its installation location.

8. With two or more personnel, move the unit from the pallet, to the ramps, to the floor, and then to the installation location.

Figure 4.4 Ramps Attached and Leveling Feet Raised

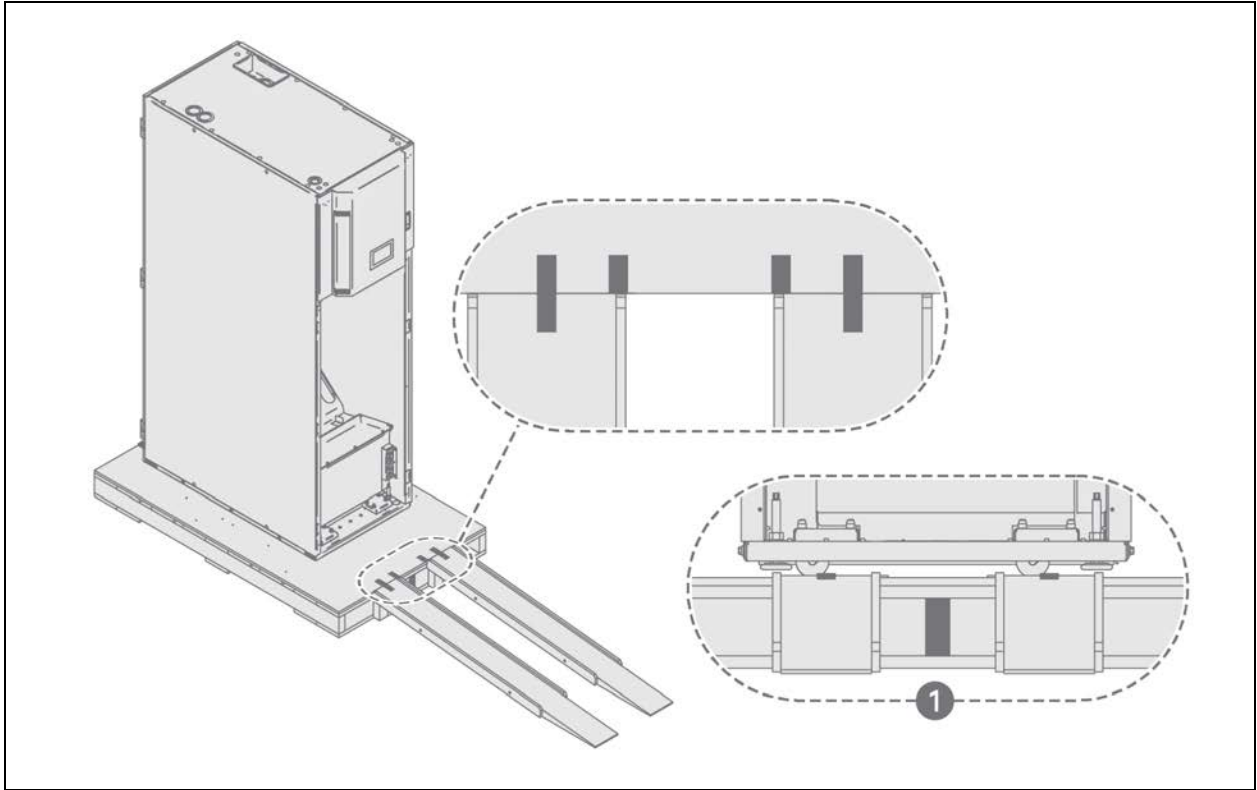

Item	Description
1	Leveling feet fully raised. Casters ready to roll.

4.6 Unpacking the Export Shipped 300 mm (24 in.) Unit

1. Remove the metal clips (12 places typical) that secure the top panel of the crate to the side panels, see **Figure 4.5** on the facing page .
2. Use a Phillips-head screw driver to remove all the wood screws (34 places typical) that secure the side panels together and to the pallet, see **Figure 4.5** on the facing page .
3. To remove the remaining packaging, start with Step 1, of [Unpacking the Domestic Shipped 300 mm \(12 in.\) Unit](#) on the facing page .

Figure 4.5 Metal Clips and Wood Screws on Crate

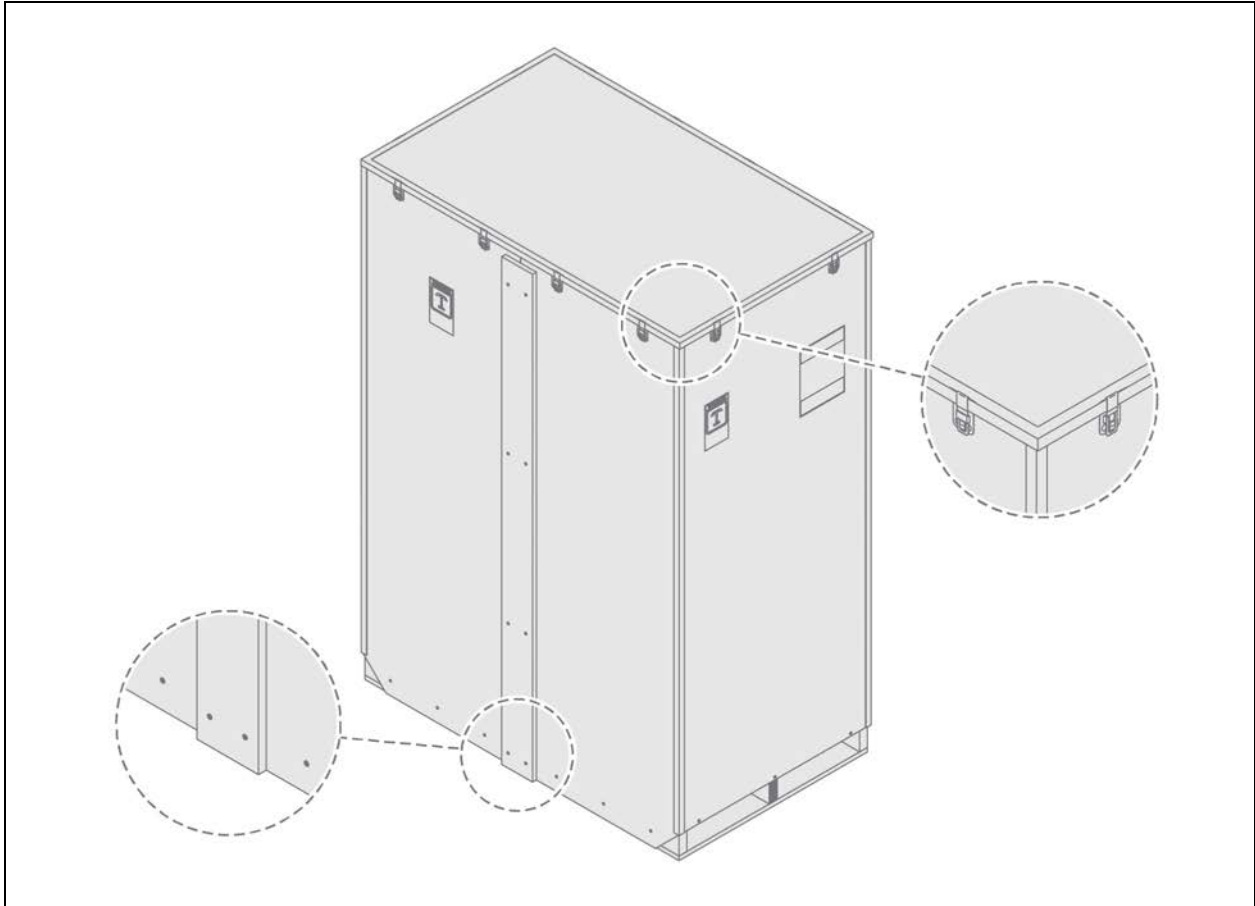

4.7 Unpacking the Domestic Shipped 300 mm (12 in.) Unit

1. Use a 9/16 in. socket drive or wrench to remove the lag screws (4 places typical) that secure the ramp to the pallet, see **Figure 4.6** on the next page. Set the ramps aside for use later when preparing move the unit from the pallet.
2. Remove the exterior packaging from around the unit

NOTE: The bag may remain in place to protect from dust and to protect the unit panels, or it may be removed for immediate installation.

3. Remove the bag from the unit when ready to move off the pallet and install the unit. See [Removing 300 mm \(12 in.\) Units from the Pallet](#) on the next page.

Figure 4.6 Lag Screws that Secure Ramps

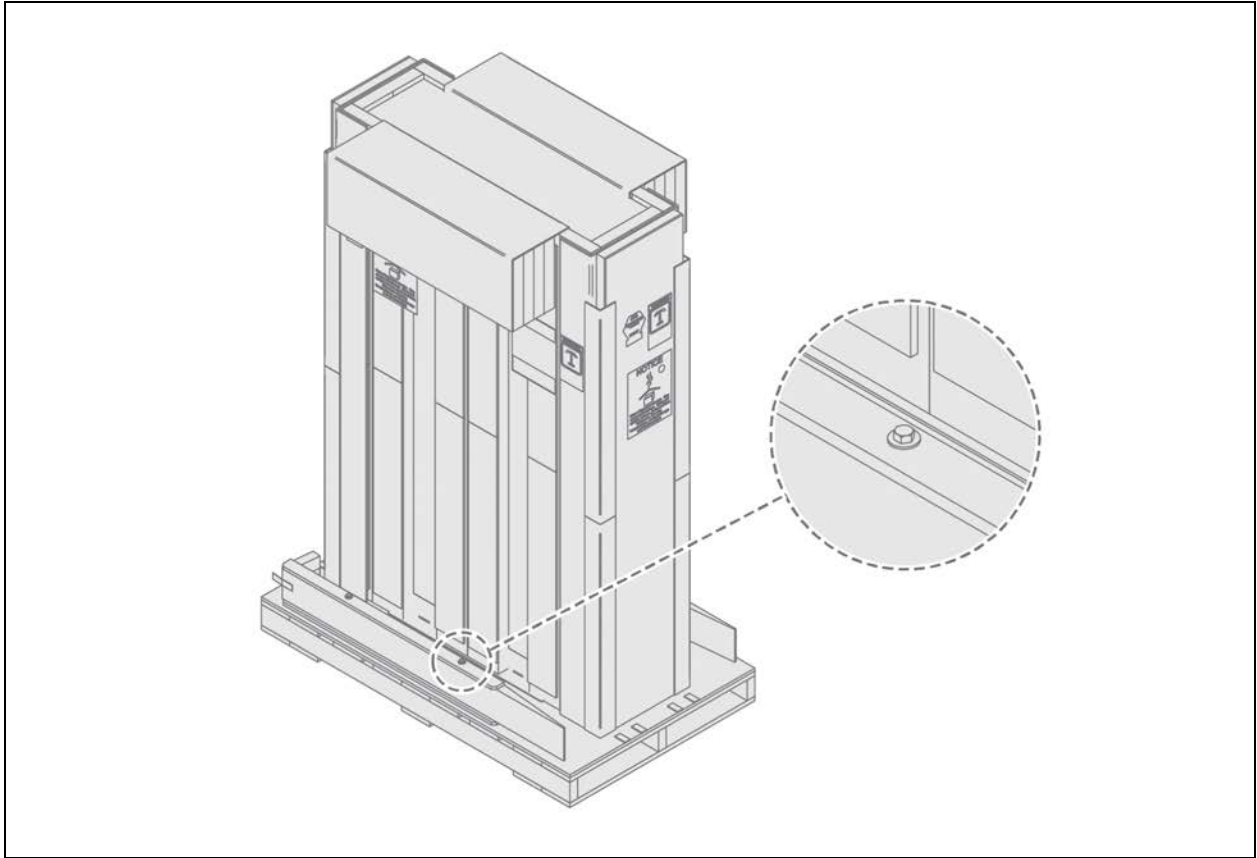

4.8 Removing 300 mm (12 in.) Units from the Pallet

1. Locate the ramps and attach to the pallet using the hook and loop strips, see **Figure 4.7** on the facing page, for placement of the strips.



WARNING! Risk of unsecured unit rolling off pallet. Can cause equipment damage, injury or death. The unit is on casters. Ensure that the pallet is located on a flat surface before loosening the hardware securing the to its shipping pallet.

2. Using a 13-mm socket-drive or wrench, remove the screws that secure the shipping brackets to the side of the unit, 3 each side, see **Figure 4.7** on the facing page .
3. Using a 9/16-in. socket-drive or wrench, remove the lag screws that secure the shipping brackets to the pallet, 3 each side, see **Figure 4.7** on the facing page .

IMPORTANT! Two or more properly-trained and qualified personnel are required to move the unit to its installation location.

4. With two or more personnel, move the unit from the pallet, to the ramps, to the floor, and then to the installation location.

Figure 4.7 Attach Ramps and Remove Shipping Brackets

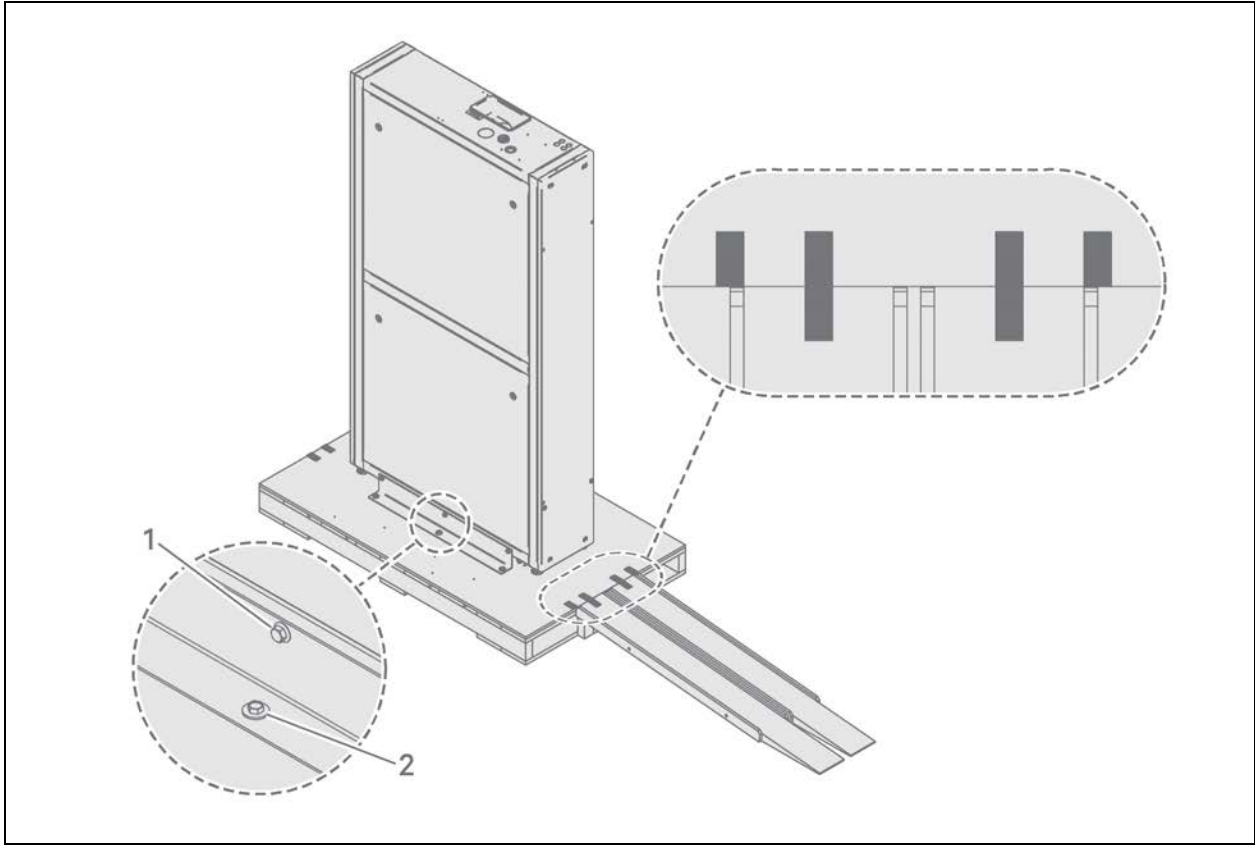

Item	Description
1	13 mm hex-head screw, 3 each side
2	9-16 in. hex-head screw, 3 each side

This page intentionally left blank

5 Installing in Enclosure Row

Built-in casters let you roll the Liebert® CRV into position for installation. For 300 mm units, optional stabilizers reduce the likelihood of the module tipping over. These stabilizers, shown in **Figure 5.1** on the next page, must be removed before the unit is positioned in the row. Adjustable leveling feet prevent it from moving after positioning, See [Adjusting Base Supports/Leveling Feet](#) below.

Once positioned, secure the unit to the floor or to an adjacent cabinet.

Adjustable brackets for attaching the unit to an adjacent cabinet are included with each unit. A bracket to attach the unit to the floor is available from your Vertiv representative.

5.1 Adjusting Base Supports/Leveling Feet

1. After the unit is in its final installation position, open the display door and remove the lower front baffle panel using a 10 mm nut driver or T30 Torx Bit to prepare for installation.
2. Open the rear panel.
3. Using an adjustable wrench, adjust the four base supports, or feet, shown in **Figure 5.1** on the next page. Ensure that the unit is level to avoid corrosion or health hazards caused by condensate accumulation.
4. Turning the base supports (leveling feet) clockwise, extends them, and lifts the unit one corner at a time.
5. Tighten the nut on the top of each foot to lock the feet. The nut on 600 mm (24 in.) units is inside the cabinet. The nut on 300 mm (24 in.) units is under the cabinet, as shown in **Figure 5.2** on page 23.

Figure 5.1 Caster Locations

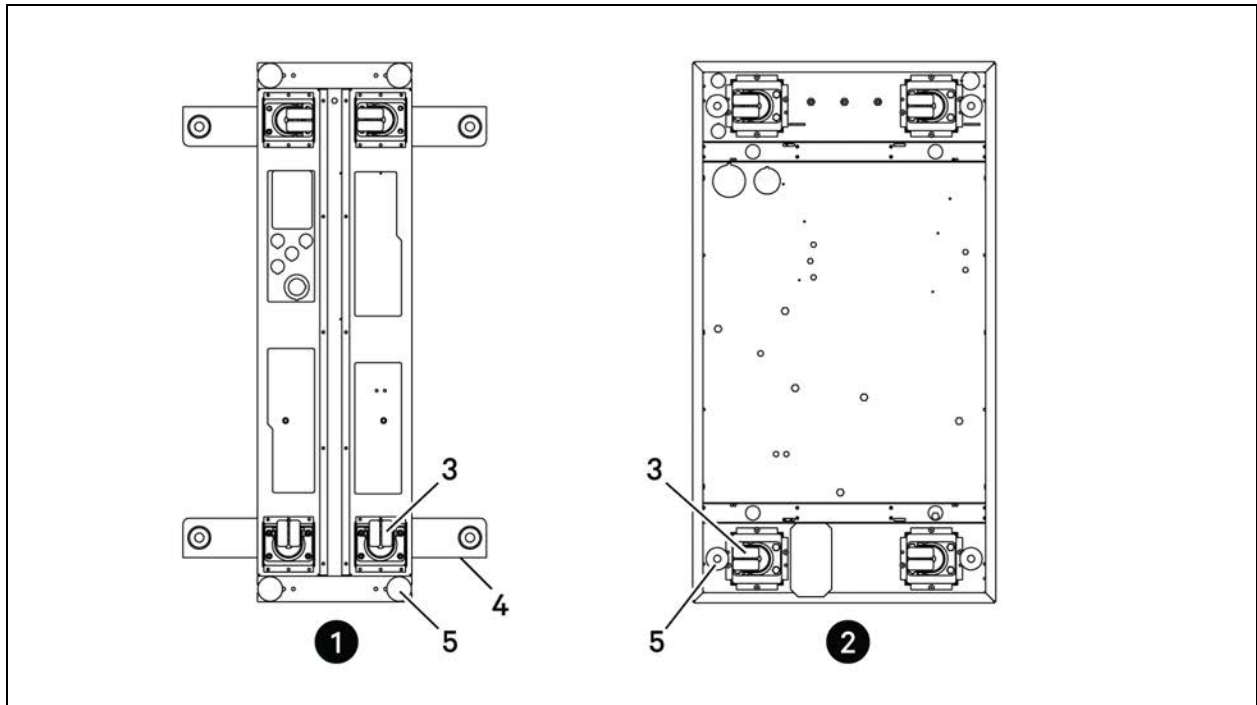

Item	Description
1	Rear of 300 mm (12 in.) unit, bottom view
2	Rear of 600 mm (24 in.) unit, bottom view
3	Caster, 1 at each corner
4	Stabilizer (optional), 1 at each corner. Only available for 300 mm (12 in.) units.
5	Adjustable leveling foot, 1 at each corner

Figure 5.2 Adjust Leveling Feet

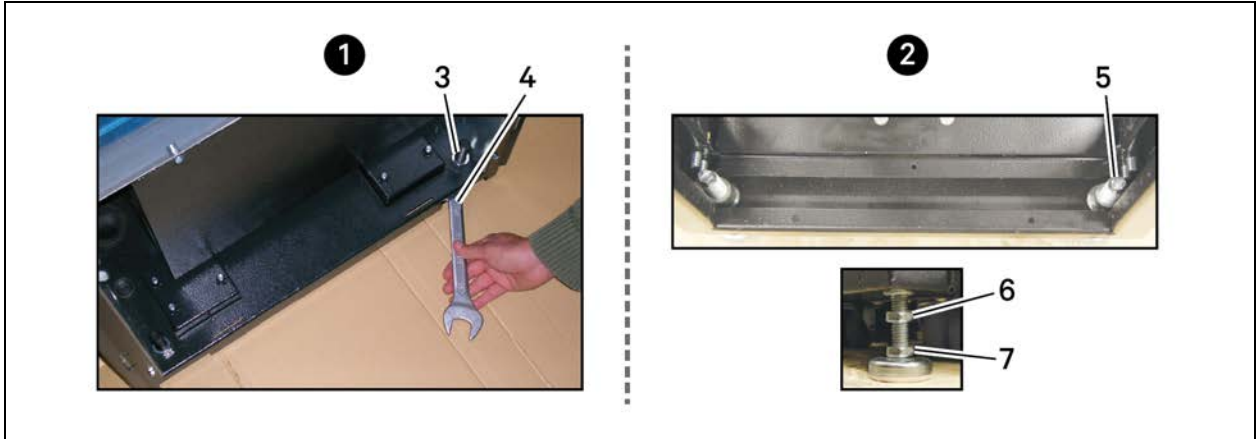

Item	Description
1	600 mm (24 in.) unit
2	300 mm (12 in.) unit
3	Nut on top of foot.
4	Adjust foot with wrench
5	Adjust foot with wrench
6	Jam nut, secures foot and final height
7	Nut to raise/lower foot.

5.2 Optional Tie Down Brackets for 300 mm (12 in.) Units

An optional tie down bracket may be installed on the unit to secure it in the row. The bracket keeps the space between the cooling unit and adjacent equipment constant, preventing noise from vibration.

! WARNING! Risk of electric shock and/or improper drilling. Can cause equipment damage, injury or death. Open all local and remote electric power disconnect switches, verify that power is off with a voltmeter and verify that no servers or other equipment is located in the intended area for drilling or use of mounting screws. Verify that there are no electric wires or equipment that may be damaged by the drill or by the resulting shavings and debris.

5.2.1 What's Included

- Brackets: 4 (2 piece, L-shaped components; for cabinets of different heights)
- Bracket tie-downs: 2 (flat brackets; for cabinets of same height)
- M6 bolts: 2
- M6 nuts: 2
- Washers: 2
- Self-tapping screws: 16

5.2.2 Tools Required

- Screwdriver, Phillips #2 Bit
- Drill
- Drill bit: 1/8" diameter
- 10 mm wrench or adjustable wrench

5.2.3 Installing Tie Down Brackets on 300 mm (12 in.) and on Cabinets of Different Heights

To install the tie down bracket:

1. Insert the M6 bolt through the longest slot in the two-piece tie-down bracket as shown in **Figure 5.3** on the facing page .
2. Secure the tie-down bracket loosely with the washer and M6 nut.
3. Position the tie-down bracket over the factory fabricated holes on the top of the Liebert® CRV and over the top of the adjacent cabinet as shown in [Tie Down Bracket on Cabinets of Different Heights—300 mm \(12 in.\)](#) on the facing page .
4. Mark where the self-tapping screws will attach the tie down bracket to the adjacent cabinet.
5. Taking proper precautions to collect the metal shavings and protect equipment, drill holes in the adjacent cabinet for the two screws.
6. Use a vacuum cleaner or other method to remove all metal particles.
7. Position the bracket over the holes in the Liebert® CRV and the adjacent cabinet.
8. Insert and tighten the four screws.
9. Tighten the M6 nut installed in step 2 securely.

Figure 5.3 Tie Down Bracket on Cabinets of Different Heights—300 mm (12 in.)

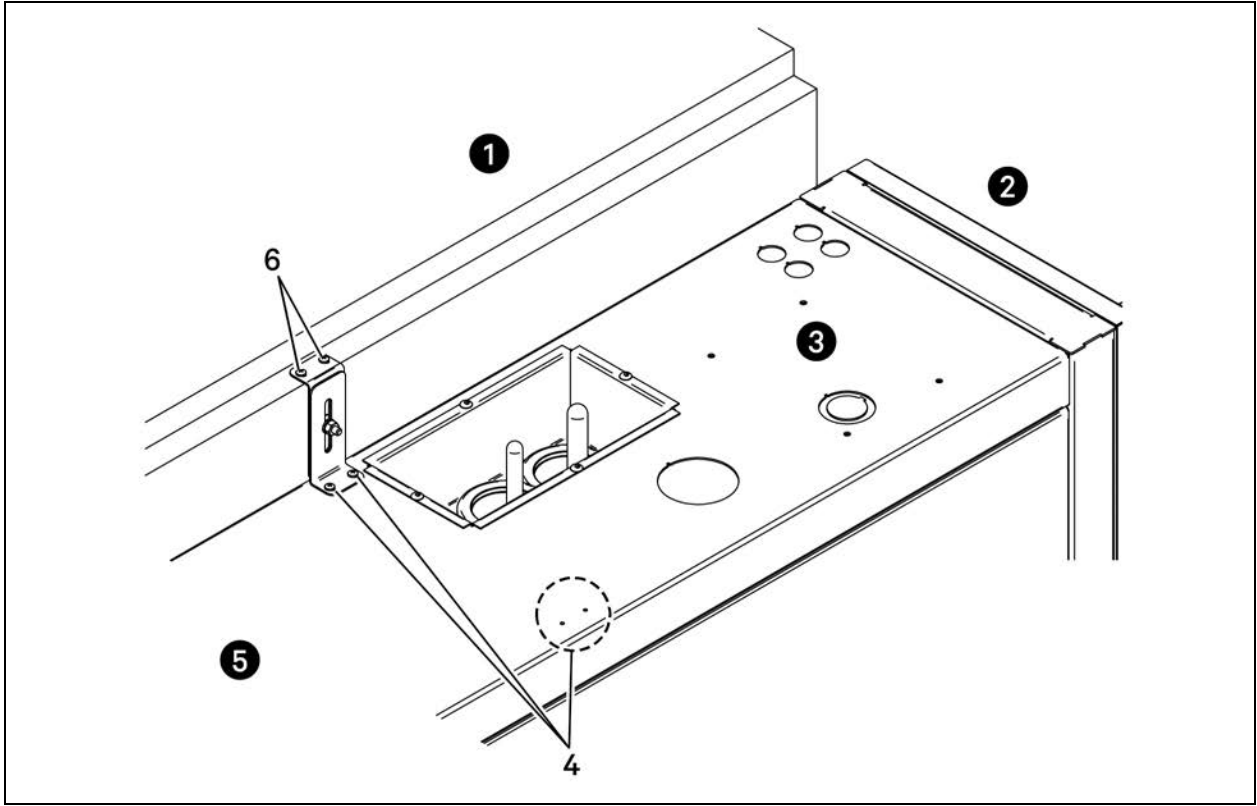

Item	Description
1	Top of adjacent cabinet
2	Rear of unit
3	Top of unit
4	Screw holes for tie-down brackets
5	Front of unit
6	Screws in drilled holes.

5.2.4 Installing Tie Down Brackets on 300 mm (12 in.) and on Cabinets of the Same Height

To install the tie down bracket:

1. Position the tie-down bracket over the factory fabricated holes on the top of the Liebert® CRV and over the top of the adjacent cabinet of the same height as shown in **Figure 5.4** below .
2. Mark where the self-tapping screws will attach the tie-down bracket to the adjacent cabinet.
3. Taking proper precautions to collect the metal shavings and protect equipment, drill holes in the adjacent cabinet for the two screws.
4. Use a vacuum cleaner or other method to remove all metal particles.
5. Position the bracket over the holes in the Liebert® CRV and the adjacent cabinet.
6. Insert and tighten the four screws.

Figure 5.4 Tie Down Bracket on Cabinets of the Same height—300 mm (12 in.)

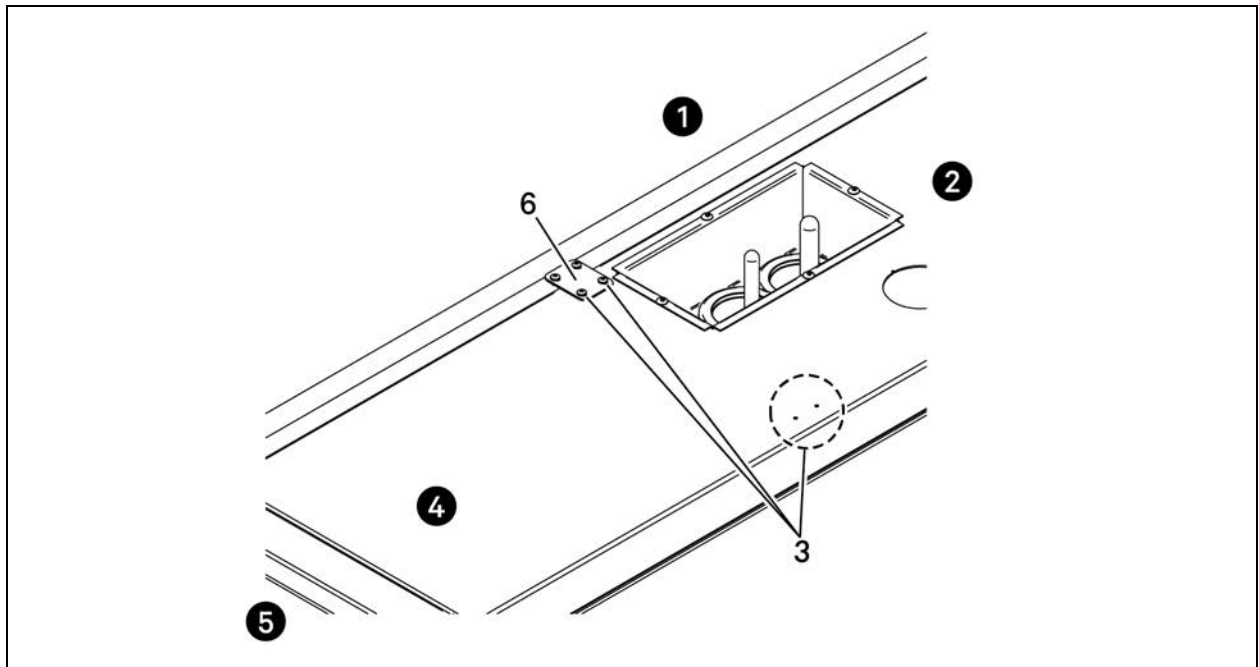

Item	Description
1	Top of adjacent cabinet
2	Rear of unit
3	Screw holes for tie-down brackets
4	Top of the unit
5	Front of the unit
6	Bracket

6 Piping and Refrigerant Requirements

The chilled water and water/glycol piping use threaded connections. The air cooled unit and internal refrigeration connections are sweat copper. The humidifier and condensate supply are threaded connections. To remove threaded plugs a backer wrench must be used. If there is difficulty removing the plugs, installer may use a heat gun, no higher to 338 F° (170°C) to breakdown the Loctite (glue), vent the system first, keep internal piping free from scale. Factory installed piping brackets must not be removed. Field installed piping must be installed in accordance with local codes and must be properly assembled, supported, isolated and insulated. Avoid piping runs through noise sensitive areas, such as office walls and conference rooms.

Refer to specific text and detailed diagrams in this manual for other unit-specific piping requirements.

All piping below the elevated floor must be arranged so that it offers the least resistance to airflow. Careful planning of the piping layout under the raised floor is required to prevent the airflow from being blocked. When installing piping on the subfloor, we recommend installing the pipes in a horizontal plane rather than stacked one above the other. Whenever possible, the pipes should be run parallel to the airflow.

The pipe connection locations, piping general arrangement and schematics are described in the submittal documents included in the [Submittal Drawings](#) on page 131 .

The following tables list the relevant documents by number and title.

Table 6.1 Piping General Arrangement Drawings

Document Number	Title
Air Cooled Systems	
DPN002858	General Arrangement Diagram 600 mm (24 in.) Air Cooled with Liebert® MC Models
DPN002808	General Arrangement Diagram 300 mm (12 in.) Air Cooled with Liebert® MC Models
Water/Glycol Cooled Systems	
DPN001985	General Arrangement Diagram 600 mm (24 in.) Water/Glycol Cooled Models
DPN003039	General Arrangement Diagram, 300 mm (12 in) Water/Glycol Cooled Models
Chilled Water Systems	
DPN001986	General Arrangement Diagram 600 mm (24 in.) Chilled Water Models
DPN002976	Primary Connection Locations CR040 Chilled Water Models

Table 6.2 Piping Connection Drawings

Document Number	Title
Air Cooled Systems	
DPN003954	Air Cooled Piping Schematic Condenser Above Indoor Unit
DPN001792	Primary Connection Locations CR020RA & CR035RA Air Cooled Models
DPN002813	Primary Connection Locations 300 mm (12 in.) Air Cooled Models
Water/Glycol Cooled Systems	
DPN001793	Primary Connection Locations CR020RW & CR035RW Water/Glycol Models
DPN003040	Primary Connection Locations 300 mm (12 In.) Water/Glycol Cooled Models

Table 6.2 Piping Connection Drawings (continued)

Document Number	Title
Chilled Water Systems	
DPN001794	Connection Locations, CR040R Chilled Water Models
DPN002814	Liebert® IntelliSlot Cable Connection Paths Liebert® IntelliSlot Wiring Routing Top of Unit 300 mm (12 in.) all Models
DPN002815	Primary Connections 300 mm (12 in.) Chilled Water Models

6.1 Drain and Humidifier Fluid Piping

NOTICE

Risk of water leakage. Can cause severe property damage and loss of critical data center equipment.

The Liebert® CRV requires a water drain connection. The 600 mm (24 in.) model may require an external water supply to operate the humidifier. Improper installation, application and service practices can result in water leakage from the unit.

Do not locate the unit directly above any equipment that could sustain water damage.

We recommend installing monitored leak detection equipment for the water supply lines and the internal unit water lines.

6.1.1 Humidifier Water Supply Line Requirements

NOTE: The humidifier is an option on 600 mm (24 in.) units only.

NOTE: For CR050 models the humidifier is not available.

The fill valve is sized for an extended water pressure range of 30 to 80 psi.

For installations where water pressure is less than 15 psi, add a pressure-boost pump and notify your Vertiv representative. A fill valve with an oversized opening will be supplied.

For installations where water pressure is greater than 80 psi, install a pressure reducing valve in the water feed line to the unit.

With dirty or muddy water sources (for example, some well sources), ensure proper filtration by adding an external filter to the water line entering the unit. (Consult your Vertiv for accessories such as filters.)

NOTICE

Risk of improper water supply. Can reduce humidifier efficiency or obstruct humidifier plumbing.

Do not use a hot water source. It will cause deposits that will eventually block the fill valve opening.

See [Connecting Water Supply to the Humidifier](#) on page 80 to connect the humidifier.

6.1.2 Condensate Pump Drain Line Requirements

NOTICE

Risk of water backing up in the drain line. Leaking and overflowing water can cause equipment and building damage.

Do not install an external trap in the drain line. This line already has a factory installed trap inside the cabinet (except for 300 mm (12 in.) Chilled water models). Installation of a second trap will prevent drain water flow and will cause the water to overflow the drain pan.

This line may contain boiling water. Use copper or other material that is rated for handling boiling water for the drain line. Sagging condensate drain lines may inadvertently create an external trap.

Observe the following requirements when installing and routing the drain line:

- The drain line must be located so it will not be exposed to freezing temperatures.
- The drain should be the full size of the drain connection.
- Drain is trapped internally. Do not externally trap the drain line.
- The drain line must be rigid enough that it does not sag between supports, which unintentionally creates traps.
- Use copper or other material suitable for draining water that can reach temperatures up to 212°F (100°C).
- We recommend installing monitored, under floor leak detection equipment.

When your unit includes the factory installed, optional condensate pump, refer to the additional details and specific installation instructions depending on the configuration of your unit:

- [Condensate Pump Drain Piping for 600 mm \(24 in.\) Models](#) below
- [Bottom Connection for Humidifier Supply and Condensate Drain Water on 600 mm \(24 in.\) Water/Glycol Systems](#) below
- [Condensate Pump Drain Piping for 300 mm \(12 in.\) Models](#) on the next page

Condensate Pump Drain Piping for 600 mm (24 in.) Models

- 1/2 in. FPT connection is provided on units with top and bottom connections for optional factory installed condensate pump.
- Condensate pump is rated for approximately 6 GPM at 30 ft (22.7 l/m) at 9 m total head.
- Size piping based on available condensate head.

NOTE: For CR050 models the condensate pump drain piping is not available.

Bottom Connection for Humidifier Supply and Condensate Drain Water on 600 mm (24 in.) Water/Glycol Systems

NOTE: A humidifier is optional: See [Humidifier 600 mm \(24 in.\) Units Only](#) on page 79 .

Units with a condensate pump and humidifier are preset to be connected from the top. If floor connections are used, the water lines can be intercepted at the following points shown in **Figure 6.1** on the next page .

Figure 6.1 Water Connection Points, Bottom Entry, 600 mm (24 in.) Models

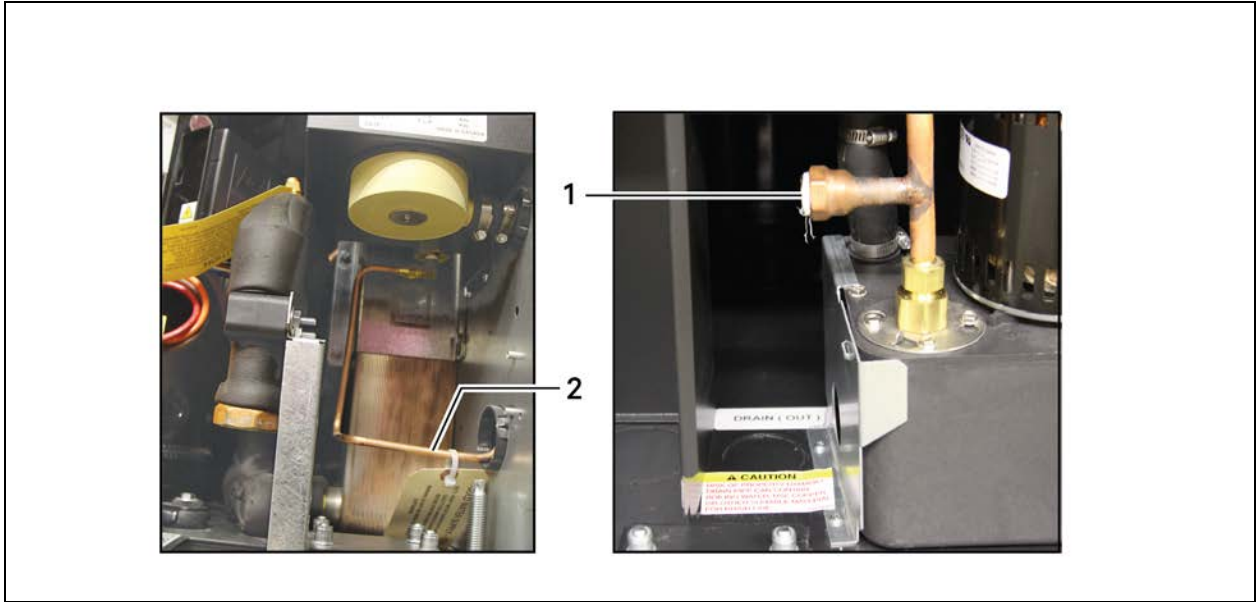

Item	Description
1	Condensate pump drain
2	Humidifier water supply

6.1.3 Condensate Pump Drain Piping for 300 mm (12 in.) Models

- Condensate pump is rated for approximately 4.6 GPH at 17 feet (0.28l/m at 5.18 m) total head. Maximum coil condensate design flow rate is 4.6 GPH.
- Size piping based on available condensate head.

Before connecting the drain line, refer to the appropriate instructions to the discharge hose to the drain line opening based on the cooling type of the unit:

- [Connecting Discharge Hose on Air Cooled, 300 mm \(12 in.\) Models](#) on the facing page
- [Connecting Discharge Hose on Water/Glycol Cooled, 300 mm \(12 in.\) Models](#) on page 32
- [Connecting Discharge Hose on Chilled Water, 300 mm \(12 in.\) Models](#) on page 34

Connecting Discharge Hose on Air Cooled, 300 mm (12 in.) Models

The unit has a 3/8 in. ID x 5/8 in. OD vinyl hose on the condensate discharge with a factory installed 3/8-in hose barb. Refer to **Figure 6.3** on the next page for the condensate pump components.

For field connection to the drain piping, a factory supplied 1/2 in. MPT x 3/8 in. hose-barb threaded adapter is included.

Figure 6.2 Condensate Pump Piping Adapters, Air Cooled, 300°mm (12°in.)

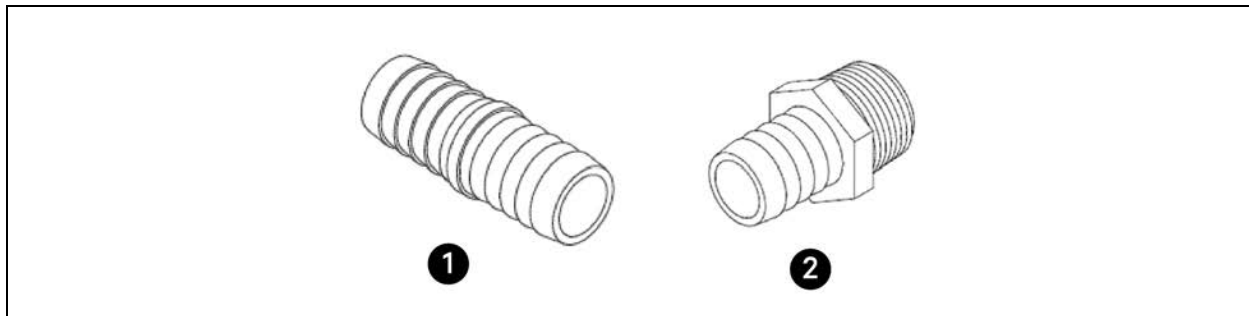

Item	Description
1	3/8 in. Nylon adapter hose (factory supplied, installed on the condensate pump.)
2	1/2 in. MPT X 3/8 in. hose barb threaded adapter (factory supplied)

For top discharge:

Connect the discharge tubing to the tubing exiting the top of the unit.

For bottom discharge:

Run the tubing out the bottom of the unit.

Figure 6.3 Condensate Pump Drain Piping, Air Cooled, 300 mm (12 in.)

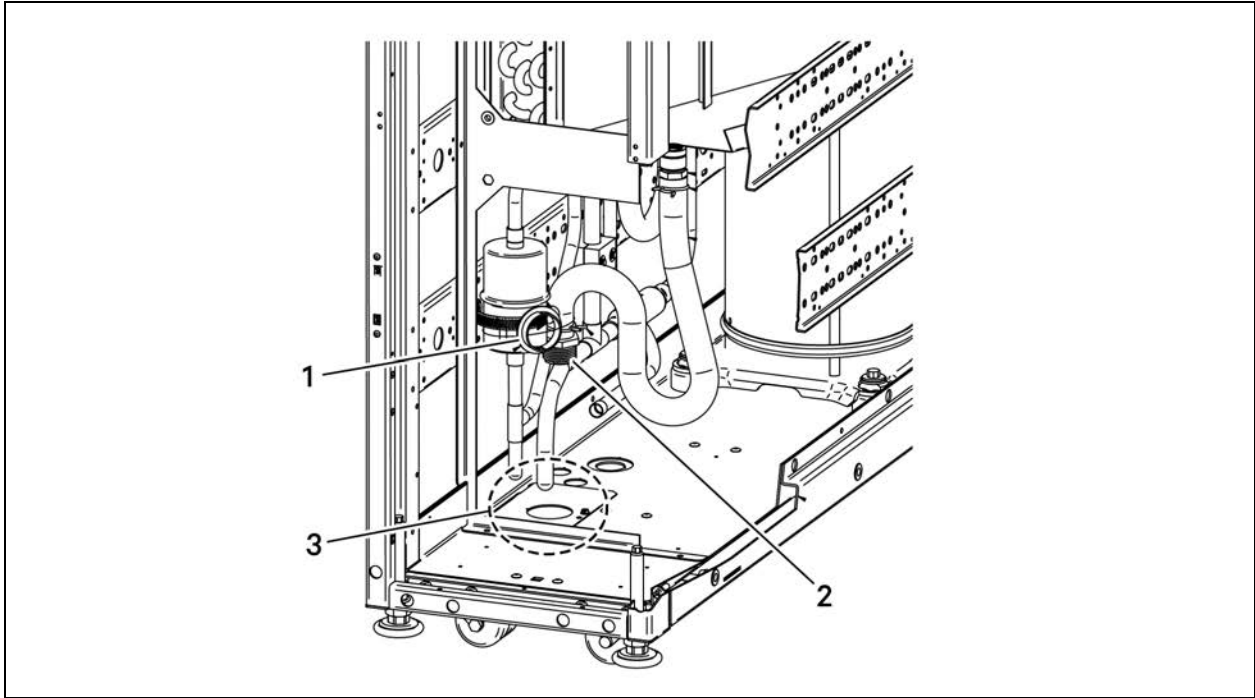

Item	Description
1	Bushing for bottom condensate exit (field installed in drain line knockout hole)
2	Hose barb (field installed)
3	Drain line knockout

Connecting Discharge Hose on Water/Glycol Cooled, 300 mm (12 in.) Models

The 300 mm (12 in.) water/glycol cooled units have separate models for top and bottom fluid connections. Both have a factory installed top discharge for the condensate pump drain connection. The discharge can be changed to the bottom of the unit in the field.

The unit has a 3/8 in. ID x 5/8 in. OD vinyl, drain hose on the condensate discharge with a factory installed 3/8 in. hose barb. Refer to the figure for the condensate pump components.

For field connection to the drain piping, a factory supplied 1/2 in. MPT x 3/8 in. hose barb threaded adapter is included.

For top discharge:

Connect the discharge tubing to the tubing exiting the top of the unit.

For bottom discharge, run the condensate drain through the bottom of the unit:

Refer to the following figure and:

1. Unbolt the fasteners that hold the condensate pump in the unit.
2. Unplug the fan wiring pin connectors from the fan control board and remove the fan control board.
3. Loosen the hose barb and hole bushing from the condensate pump.

- 4. Remove the drain line from the evaporator coil and pump discharge line.
- 5. Remove the condensate pump.
- 6. Remove the wire ties that secure the wire harness inside the corner post to get slack in the wires.
- 7. Remove the vertical access plate behind the pump and fan control board.
- 8. Remove the access plate beside the brazed plate exchange so that unit the condensate drain line can be run under the unit.

Figure 6.4 Condensate Pump Drain Piping, Water/Glycol Cooled, 300 mm (12 in.)

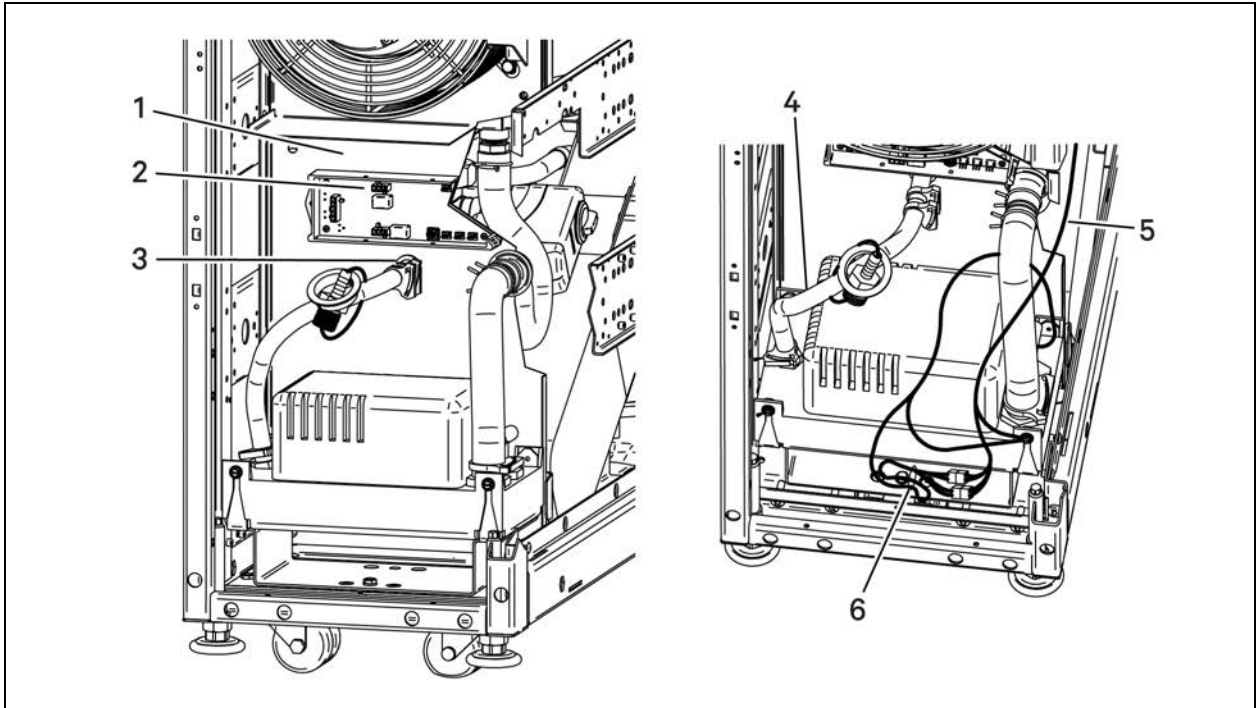

Item	Description
1	Back panel
2	Fan control board
3	Bushing for bottom condensate exit (field installed in drain line knockout hole)
4	Drain hose
5	Wiring from electrical panel
6	Wire ties on wiring routed inside frame

Connecting Discharge Hose on Chilled Water, 300 mm (12 in.) Models

The unit has a 3/8 in. ID x 5/8 in. OD vinyl hose on the condensate discharge with a factory installed 3/8 in hose barb. Refer to the figure for the condensate pump components.

For field connection to the drain piping, a factory supplied 1/2 in. MPT x 3/8 in. hose barb threaded adapter is included.

For top discharge:

Refer to the following figure and:

1. Remove the factory supplied adapter that is tied to the condensate line inside the unit.
2. Insert the adapter into the factory installed condensate line at the top of the unit.
3. Insert the barbed connection of the condensate pump line into the factory installed condensate line.
4. Connect field supplied drain line to the connection at the top of the unit.
5. Using field supplied clamps, clamp all connections as needed.

For bottom discharge:

Refer to the following figure and:

1. Remove the factory supplied adapter and bushing that are tied to the condensate line inside the unit.
2. Remove the barbed adapter from the condensate pump discharge hose.
3. Insert the adapter into the condensate pump discharge hose.
4. Remove the knockout in the plate inside the bottom of the unit, and insert the bushing into the knockout.
5. Run the condensate pump discharge hose through the bushing in the bottom of the unit.
6. Connect field installed drain line to the connection under the unit.
7. Using field supplied clamps, clamp all connections as needed.

Figure 6.5 Condensate Pump Drain Piping, Chilled Water, 300 mm (12 in.)

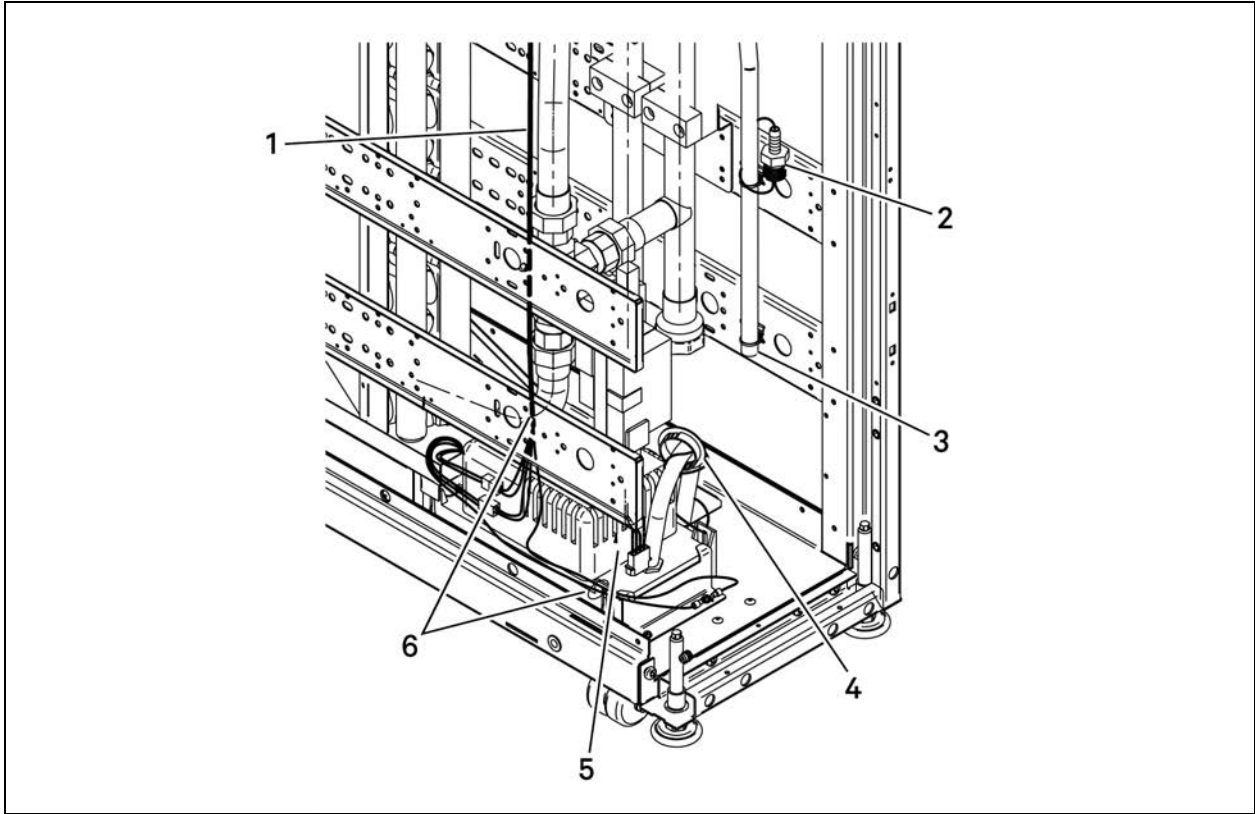

Item	Description
1	Wiring harness from electrical panel to condensate pump
2	Adapter (field installed)
3	Condensate drain tubing, top exit
4	Bushing for bottom condensate exit (field installed in drain line knockout hole)
5	Condensate pump
6	Service loop of high and low voltage wiring for condensate pump removal. Make sure the service loop remains, and coil as necessary.

6.1.4 Field Installed, Gravity Fed Drain Line Requirements

NOTICE

Risk of water backing up in the drain line. Leaking and overflowing water can cause equipment and building damage.

Do not install an external trap in the drain line. This line already has a factory installed trap inside the cabinet (except for 300 mm (12 in.)) Chilled water models). Installation of a second trap will prevent drain water flow and will cause the water to overflow the drain pan.

This line may contain boiling water. Use cooper or other material that is rated for handling boiling water for the drain line. Sagging condensate drain lines may inadvertently create an external trap.

- A 3/4 in. FPT connection is provided on models with no humidifier.
- A 1-1/4 in. FPT connections is provided on models with a steam-generating humidifier.

Observe the following requirements when installing and routing the drain line:

- The drain line must be sized for 2 gpm (7.6 l/m) flow.
- The drain line must be located so it will not be exposed to freezing temperatures.
- The drain should be the full size of the drain connection.
- The drain line must slope continuously away from the unit. Pitch drain line toward drain a minimum of 1/8 in. (3 mm) per 1 ft (305 mm) of length.
- The drain line must be rigid enough that it does not sag between supports, which unintentionally creates traps.
- The drain line must comply with all applicable codes.

Figure 6.6 Correct and Incorrect Gravity Drain Piping on all 600 mm (24 in.) and Water/Glycol Cooled 300 mm (12 in.) Models

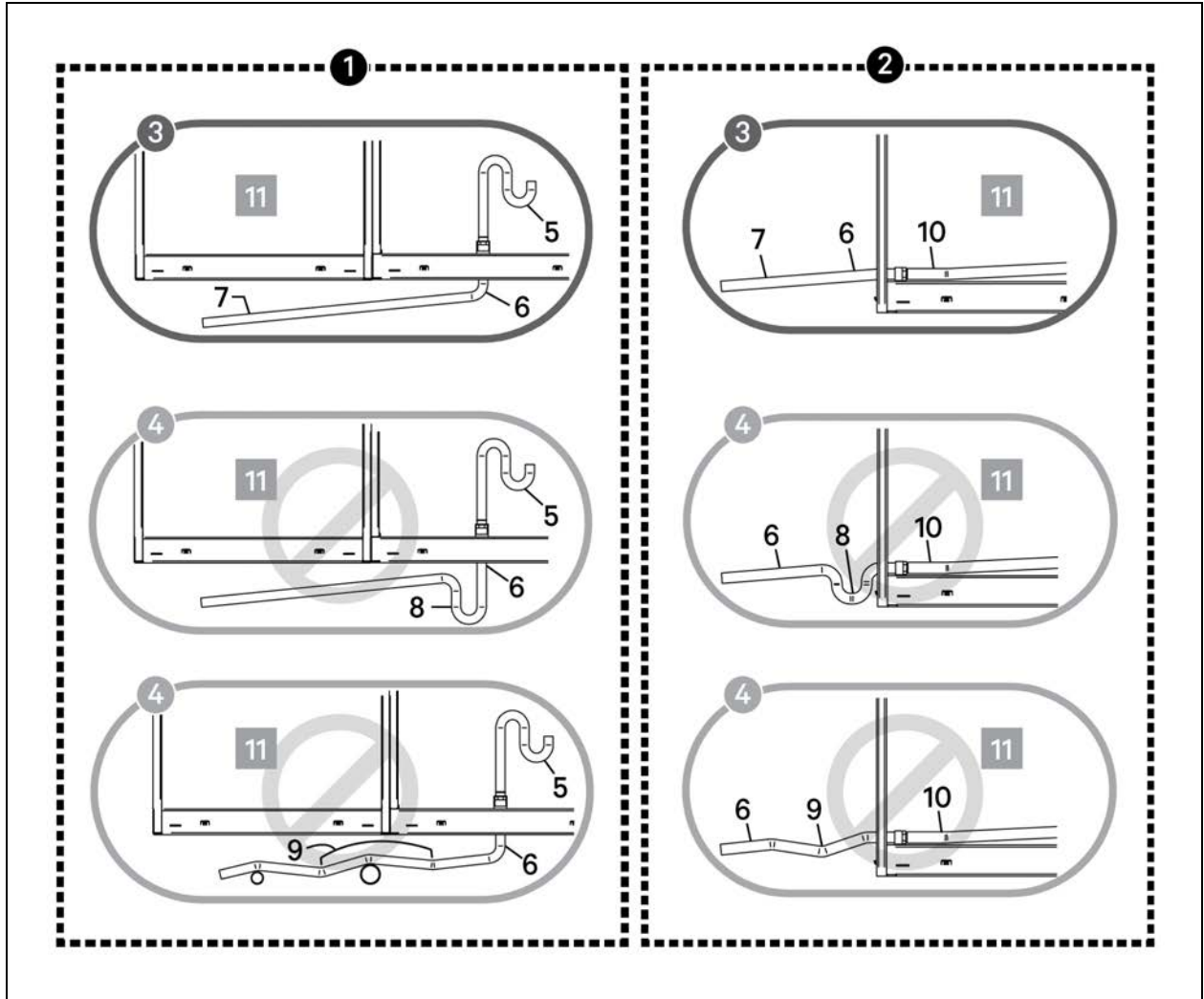

Item	Description	Item	Description
1	For downflow units	7	Continuous downward slope
2	For upflow units	8	External trap. Do not trap externally.
3	Correct drain installation	9	External traps, although unintentional. Lines must be rigid enough to bow.
4	Incorrect drain installation	10	Internal drain
5	Internal drain	11	CRV unit
6	External drain		

Connecting Gravity Drain Line on All 600 mm (24 in.) Models and on Air and Water/Glycol Cooled 300 mm (12 in.) Models

1. Remove the factory supplied adapter and bushing that are tied to the condensate line inside the unit.
2. Remove the knockout in the plate inside the bottom of the unit, and insert the bushing into the knockout.
3. Run the evaporator drain line through the bushing in the bottom of the unit.
4. Connect field installed drain line to the discharge hose.
5. Using field supplied clamps, clamp all connections as needed.

Figure 6.7 Gravity Drain Line Connection on Air Cooled, 300 mm (12 in.) Unit

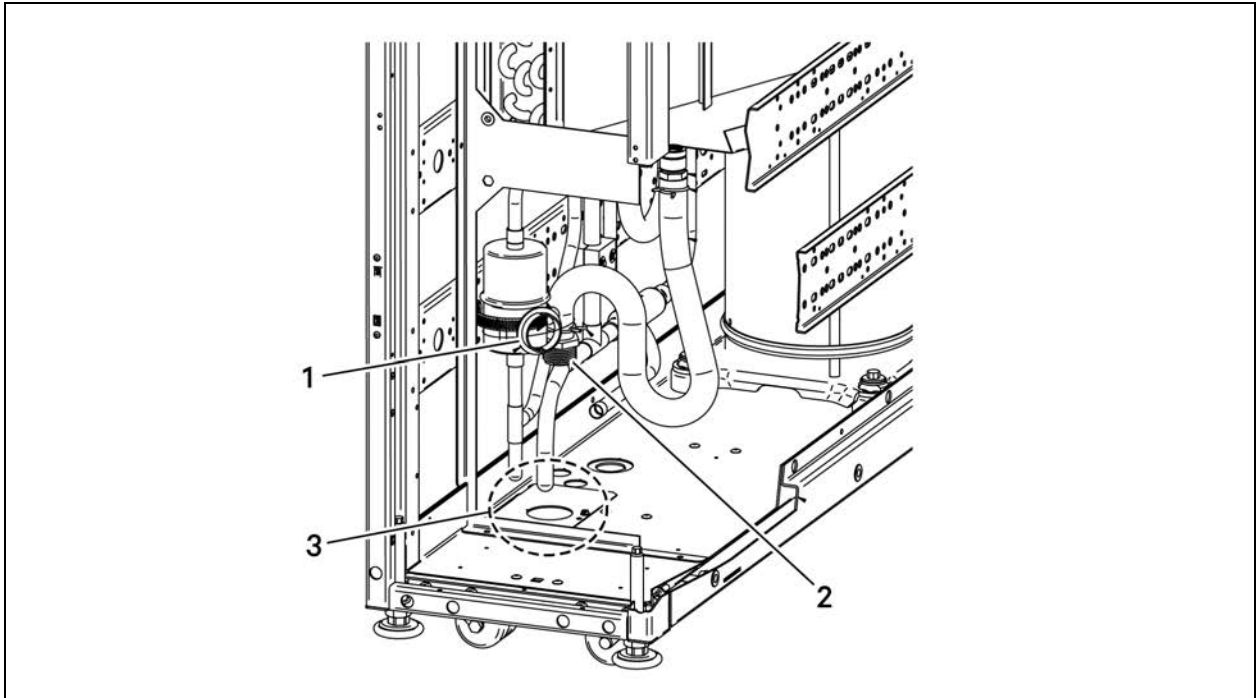

Item	Description
1	Bushing for installation after knockout is removed
2	Adapter, 1 in. NPT male – 3/4 in. barb
3	When coolant supply/return is top-entry, remove this plate, remove the knockout for the drain, and then re-install the plate.

Figure 6.8 Gravity Drain Line Connection on all 600°mm°(24°in.) unit

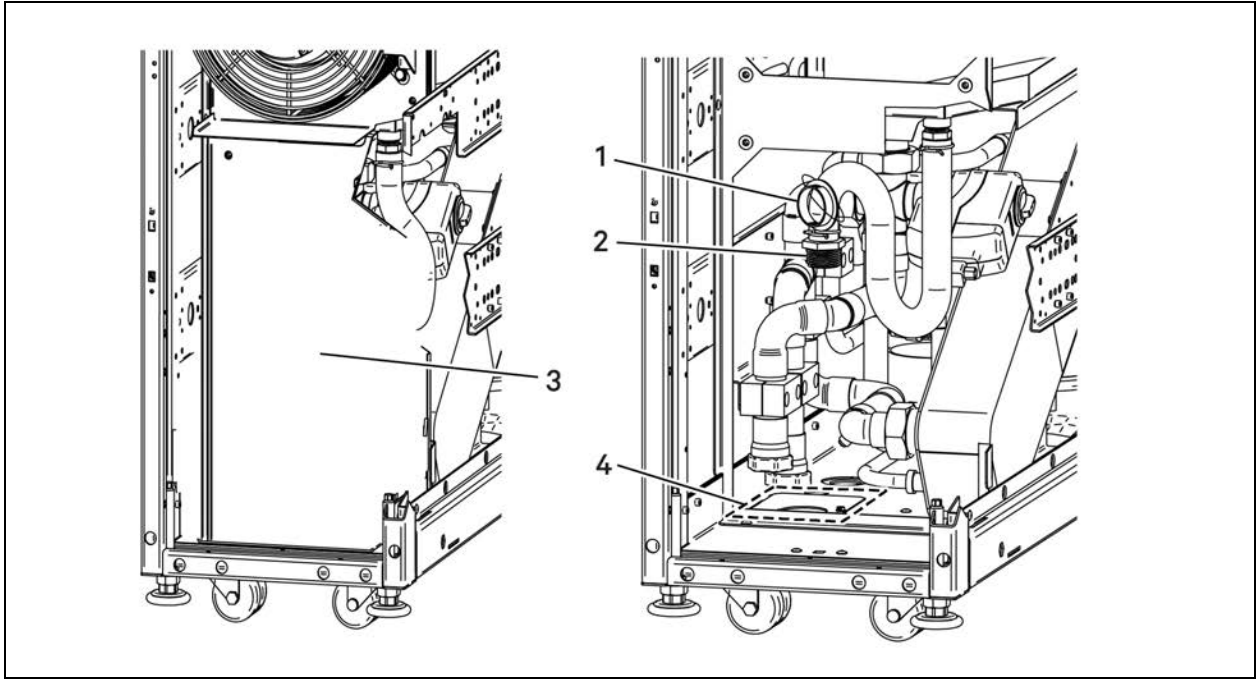

Item	Description
1	Bushing for installation after knockout is removed
2	Adapter, 1 in. NPT male – 3/4 in. barb
3	When coolant supply/return is top entry, remove this plate, remove the knockout for the drain, and then re-install the plate.

Connecting Gravity Drain Line on Water/Glycol Cooled, 300 mm (12-in.) Models

- 1. Remove the access plate, shown in Figure 6.9 on the next page .
- 2. Route the evaporator drain line through the bottom of the unit at unit bottom access plate.
- 3. Fill the drain trap with tap water.

Figure 6.9 Gravity Drain Line Connection on Water/Glycol Cooled, 300 mm (12-in.) Unit

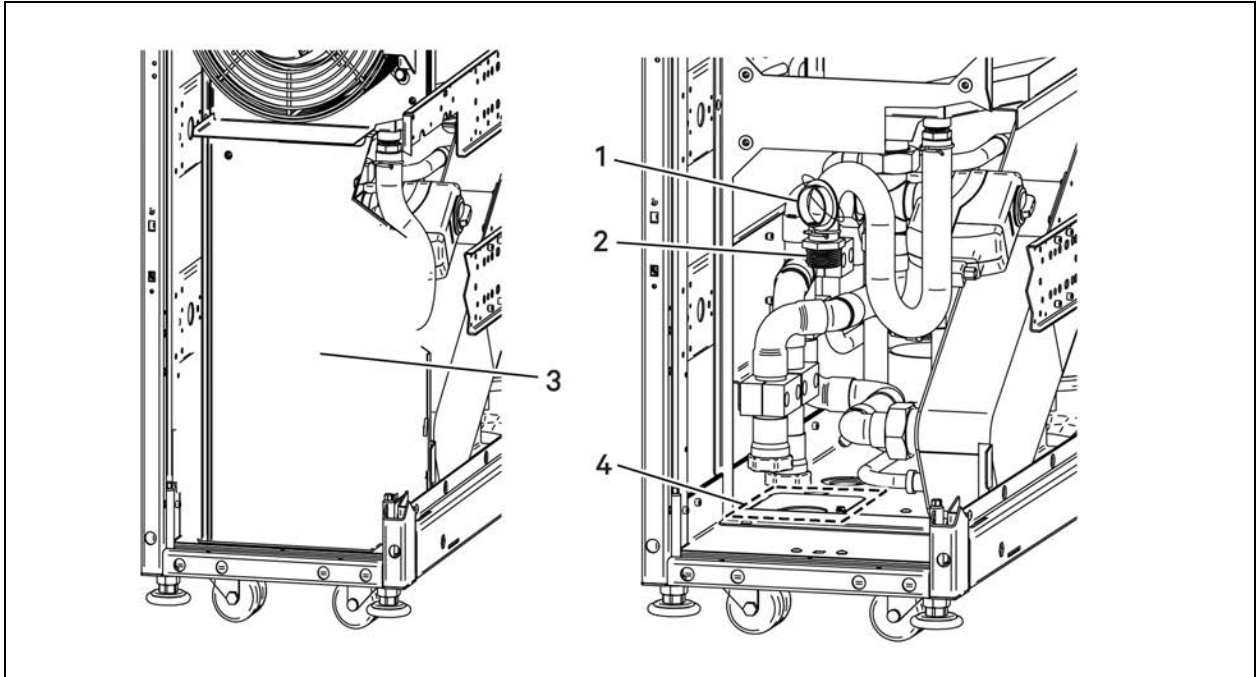

Item	Description
1	Bushing (field installed after knockout removed)
2	Adapter, 1 in. NPT Male – 3/4 in. barb
3	Access plate
4	When coolant supply/return is top entry, remove this plate, remove the knockout for the drain, and then re-install the plate.

Connecting Gravity Drain Line on Chilled Water, 300 mm (12-in.) Models

1. Remove the factory supplied hose barb, bushing and trap that are tied to piping inside the unit.
2. Remove the knockout in the plate in the bottom of the unit, and insert the bushing into the knockout.
3. Insert factory supplied drain trap through bushing with 90 degree barb inside the unit and the trap beneath the unit.
4. Connect the barb to the factory installed condensate line.

Figure 6.10 Gravity Drain Line Connection on Chilled Water, 300°mm (12 in.) Units

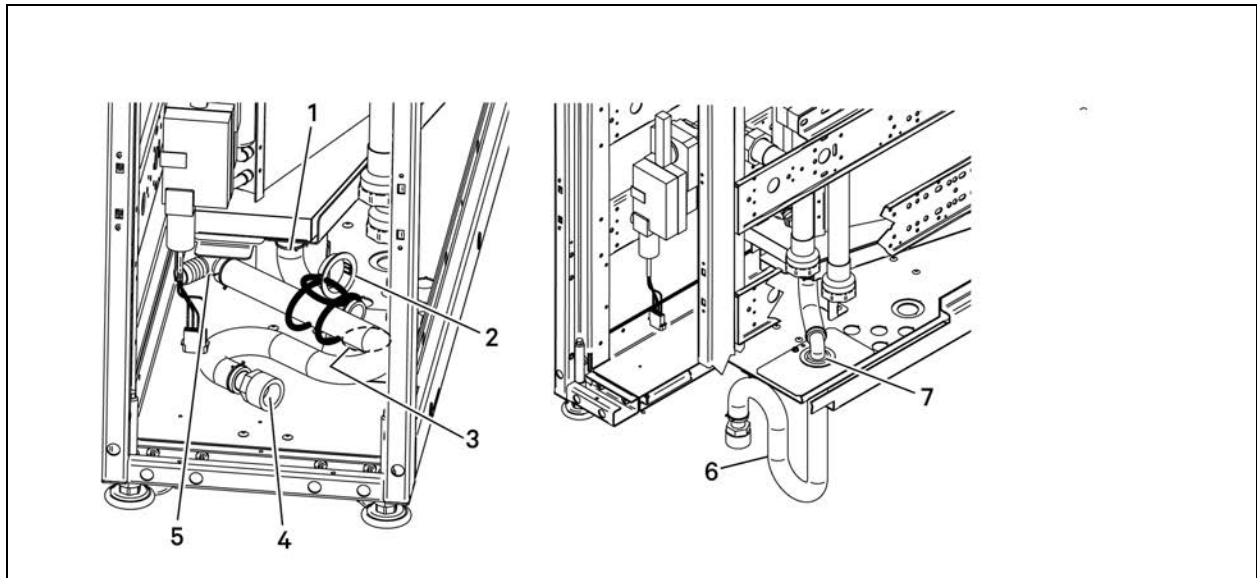

Item	Description
1	Condensate drain (factory installed)
2	Bushing (field installed after knockout removed)
3	Knockout location below drain tubing (not visible in figure)
4	Connect to field supplied drain line
5	90 degree hose barb
6	Condensate drain and trap under units without a condensate drain pump
7	Condensate drain tubing routed through bushing/knockout

6.2 Refrigerant Piping and Charging



WARNING! Risk of over pressurization of the refrigeration system. Can cause explosive discharge of high pressure refrigerant, loss of refrigerant, environmental pollution, equipment damage, injury, or death. This unit contains fluids and gases under high pressure. Use extreme caution when charging the refrigerant system. Do not pressurize the system higher than the design pressure marked on the unit's nameplate.



CAUTION: Risk of excessive refrigerant line pressure. Can cause tubing and component rupture resulting in equipment damage and personal injury. Do not close off the refrigerant line isolation valve for repairs unless a pressure-relief valve is field installed in the line between the isolation valve and the check valve. The pressure relief valve must be rated 5% to 10% higher than the system design pressure. An increase in ambient temperature can cause the pressure of the isolated refrigerant to rise and exceed the system design pressure rating (marked on the unit nameplate).

Consult local building and plumbing codes for installation requirements of additional pressure relief devices when isolation valves are field installed. Do not isolate any refrigerant circuits from over pressurization protection.

NOTICE

Risk of oil contamination with water. Can cause equipment damage.

Liebert® CRV systems require the use of POE (polyolester) oil. POE oil absorbs water at a much faster rate when exposed to air than previously used oils. Because water is the enemy of a reliable refrigeration system, extreme care must be used when opening systems during installation or service. If water is absorbed into the POE oil, it will not be easily removed and will not be removed through the normal evacuation process. If the oil is too wet, it may require an oil change. POE oils also have a property that makes them act as a solvent in a refrigeration system. Maintaining system cleanliness is extremely important because the oil will tend to bring any foreign matter back to the compressor.

NOTICE

Risk of improper refrigerant charging. Can cause equipment damage.

Refrigerant charge must be weighed into air-cooled compressorized systems before they are started. Starting scroll and digital scroll compressors without proper refrigerant charging can cause the compressors to operate at less than 5°F (–15°C) evaporator temperature and at less than 20 psig (138 kPa). Operation for extended periods at less than 20 psig (138 kPa) can cause premature compressor failure.

NOTICE

Units should never be operated with no refrigerant charge, a holding charge, a proper load or without additional oil as required added. Tag out system to prevent unauthorized personnel from accidentally starting equipment and damaging compressors if any of these conditions exist.

6.2.1 Refrigerant Piping Guidelines for Air Cooled Systems

- Air cooled units ship with a nitrogen holding charge. Do not vent the charge until all refrigerant piping is in place, ready for connection to the unit and condenser.
- Use copper piping with a brazing alloy with a minimum temperature of 1350°F (732°C), such as Sil-Fos. Avoid soft solders, such as 50/50 or 95/5.
- Use a flow of dry nitrogen through the piping during brazing to prevent formation of copper oxide scale inside the piping. When copper is heated in the presence of air, copper oxide forms. POE oils will dissolve these oxides from inside the copper pipes and deposit them throughout the system, clogging filter driers and affecting other system components.
- A pure dry nitrogen flow of 1-3 ft³/min (0.5-1.5 l/s) inside the pipe during brazing is sufficient to displace the air. Control the flow using a suitable measuring device.
- Ensure that the tubing surfaces to be brazed are clean and that all burrs have been removed from the ends of the tubes.
- Ensure that all loose material has been cleaned from inside the tubing before brazing.
- Protect all refrigerant line components within 18 in. (460 mm) of the brazing site by wrapping them with a wet cloth or with a suitable heat-sink compound.
- Isolate piping from building using vibration-isolating supports.
- Condensers with receivers cannot be installed below the evaporator. The maximum height of the condenser above the evaporator is 60 ft (18.3 m). Refer to DPN003954 included in [Submittal Drawings](#) on page 131. Consult the factory before installing units, condensers, and receivers outside these parameters.
- Pitch horizontal hot-gas piping down at a minimum rate of 1/2 in. per 10 ft (42 mm per 10 m) so that gravity will aid in moving oil in the direction of refrigerant/oil flow.
- Keep piping clean and dry, especially on units with refrigerant.
- Avoid piping runs through noise-sensitive areas.

- Do not run piping directly in front of discharge air stream.
- Refrigerant oil – do not mix oil types (see [Compressor Oil](#) on page 105).

Refer to ASHRAE Refrigeration Handbook for general, good practice refrigeration piping.

- Refer to [Refrigerant Line Sizes and Equivalent Lengths](#) on page 46 , for recommended refrigerant piping sizes based on equivalent pipe lengths.
- Refer to [Refrigerant Charge Requirements for Air Cooled Systems](#) on page 48 , for the refrigerant-charge requirements of the system.
- Refer to [Charging Air Cooled Systems with Liebert® Lee-Temp Receiver](#) on page 59 , for charging information.

6.3 Piping Guidelines for Liebert® MC Condensers

The following operations must be carried out by an experienced refrigeration technician.

NOTICE

Risk of oil contamination with water. Can cause equipment damage.

Liebert® CRV systems require the use of POE (polyolester) oil. POE oil absorbs water at a much faster rate when exposed to air than previously used oils. Because water is the enemy of a reliable refrigeration system, extreme care must be used when opening systems during installation or service. If water is absorbed into the POE oil, it will not be easily removed and will not be removed through the normal evacuation process. If the oil is too wet, it may require an oil change. POE oils also have a property that makes them act as a solvent in a refrigeration system. Maintaining system cleanliness is extremely important because the oil will tend to bring any foreign matter back to the compressor.

1. When installing the refrigerant piping, note the following:

Brazing:

- All joints must be brazed.
- Avoid butt brazes by using couplings or swaging one of the pipes with a swaging tool.
- Ensure that all brazed joints are leak free.
- Flow dry nitrogen through the pipes during brazing.

Always use large radius curves (bending radius at least equal to pipe diameter). Bend the pipes as follows:

- soft copper: bend by hand or use bending device;
- hard copper: use preformed curves.
- To minimize oxidation, avoid overheating the pipes when brazing.

2. Connect the pipes to the condenser:

- Condensers with butt brazed pipe connections: Cut the pipe, enlarge it, and braze it to the pipeline.
- Respect the direction of refrigerant flow. (See labels on refrigerant.)

3. Wash out the pipelines as follows:
 - a. Plug up the free ends of the pipes.
 - b. Connect a helium or nitrogen cylinder, fitted with a reducer (maximum pressure 10 bar), to the 1/4" SAE Schrader valve of the condenser.
 - c. Pressurize the pipes with helium or nitrogen.
 - d. Unplug the pipes instantaneously.
 - e. Repeat steps a through d several times.

This operation is especially important when hard copper piping is used.

4. Open all the shutoff valves on the room unit.
5. Discharge the room unit pressurized with helium (at 1 bar) by opening the charge valves so that all the branches of the circuit are discharged (for example, on the receiver, on the low pressure side, and on the compressor delivery).
6. Cut the spun-closed ends off the hot-gas and liquid line connections on the Liebert® CRV.
7. Fix (braze) the pipes to the connections on the air conditioner.
8. **Air Cooled Units**—Connect the refrigerant-safety pressure-relief valve to the outdoors with a 5/8 in. (16 mm) copper pipe if hot-gas and liquid-isolation valves are installed in the field.

NOTE: Not required on water/glycol units, which have an indoor relief valve.

6.3.1 Piping Layout and Condenser Positioning

The piping layout and condenser positioning is detailed in the submittal documents included in the [Submittal Drawings](#) on page 131.

The following table lists the relevant documents by number and title along with recommended insulation guidelines for the piping.

Table 6.3 Air Cooled Piping Layout and Condenser Positioning Drawings

Condenser Position:		Condenser above Indoor Unit	Condenser and Indoor Unit at Same Level	Condenser Below Indoor Unit
Insulation:				
Discharge line	Indoor	Necessary	Necessary	Necessary
	Outdoor	Only for aesthetic reasons	Only for aesthetic reasons	Only for aesthetic reasons
Liquid line:	Indoor	Only for aesthetic reasons	Only for aesthetic reasons	No, expose to under-floor air
	Outdoor		Only if exposed to sunlight	Only if exposed to sunlight
Document Number: (see Submittal Drawings on page 131.)		DPN003954, Pg. 1	DPN003954, Pg. 2	DPN003954, Pg. 3

Piping Guidelines:

1. Piping must be Type ACR copper tubing and sized per [Liebert CRV Recommended Refrigerant Line Sizes, O.D. CU for Liebert MC Condensers with and without Liebert® Lee Temp \(continued\)](#) on page 47 through **Table 6.7** on page 47.

NOTE: All field installed piping must comply with applicable national, state and local codes.

2. Use the shortest possible refrigeration pipelines to minimize the total charge of refrigerant and the number of pressure drops.

3. Minimize the number of bends and make the bends the largest radius practical to prevent constricting refrigerant flow.
4. Insulate the piping as specified in [Piping Layout and Condenser Positioning](#) on the previous page . If the pipes are installed next to electrical cables, they must be isolated from the building using vibration-isolating supports to avoid damage to cable insulation.
5. There must be at least 1 in. (25 mm) separation between the gas and liquid pipelines. If this is not possible, insulate both lines.
6. Support both horizontal and vertical pipes with vibration-damping clamps, which include rubber gaskets. Place these clamps every 5 to 7 ft (1.5 to 2 m).

Table 6.4 Maximum Equivalent Refrigerant Piping—Indoor Unit to Liebert®MC Condenser with or without Liebert® Lee-Temp

Parameter	Maximum Distances, ft (m)	
From indoor unit to condenser	300 (91.4) equivalent length	
Condenser without receiver relative to indoor unit	Above: 60 (18.3)	Below: 15 (4.5)
Condenser with receiver relative to indoor unit	Above: 60 (18.3)	Below: 0 (0)

6.3.2 Top or Bottom Connection for Refrigerant Piping on Air Cooled Units

The Liebert® CRV can be connected to a condenser through either the top or bottom of the unit. The unit is piped for connections at the top of the unit, shown in [Figure 6.11](#) below , with provisions for connection through the bottom.

Connecting through the bottom of the unit requires cutting the liquid and discharge lines as shown in [Figure 6.12](#) on the next page . Cutting these lines just below the pipe clamps disconnects the top connections from the rest of the refrigeration system.

NOTE: Clearances require using a smaller tubing cutter to make the refrigerant piping connections on the top or bottom of the unit.

Air cooled units are shipped with a holding charge of nitrogen.

Figure 6.11 Top Refrigerant Piping Connection on All Unit Models

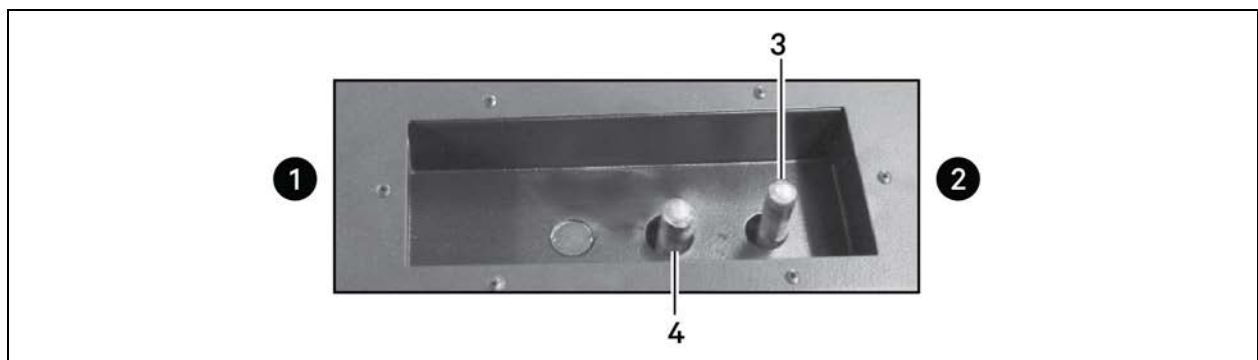

Item	Description
1	Toward front of unit
2	Toward rear of unit
3	Discharge connection
4	Liquid line connection

NOTE: Figure 6.12 below shows the pipe clamps in an Air-cooled, 600-mm model

Figure 6.12 Pipe Clamps for Cuts to Make Bottom Refrigerant Piping Connections

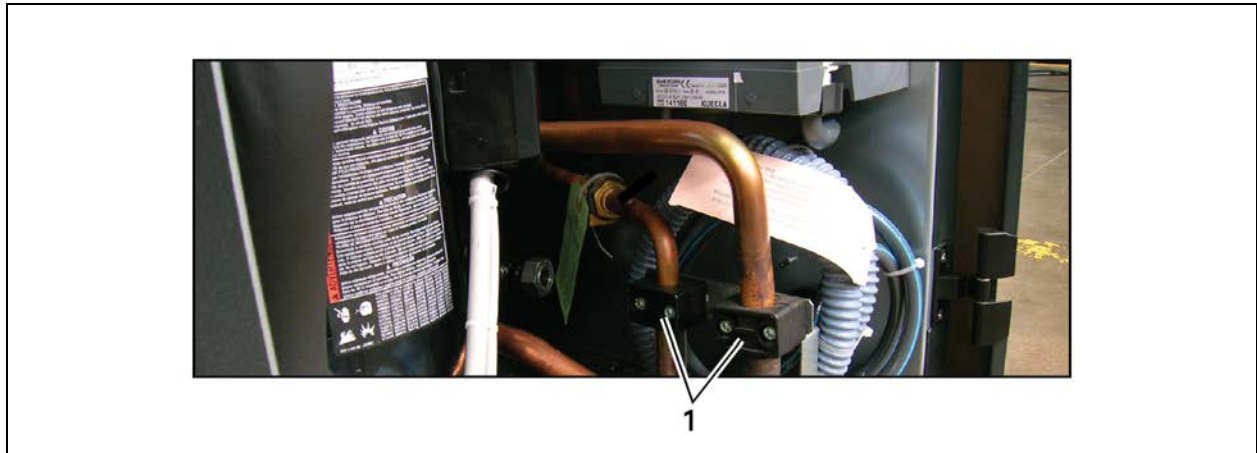

Item	Description
1	Pipe clamps (make cuts just below clamps for bottom connections)

6.3.3 Refrigerant Line Sizes and Equivalent Lengths

Table 6.5 Liebert CRV Recommended Refrigerant Line Sizes, O.D. CU for Liebert MC Condensers with and without Liebert® Lee Temp

Liebert® CRV Model Number	Total Equivalent Length, ft (m)	Hot-gas Line, in. (mm)	Liquid Line, in. (mm)
CR019RA/CR020RA	50 (15)	3/4 (19.1)	5/8 (15.9)
	100 (30)	3/4 (19.1)	5/8 (15.9)
	150 (45)	3/4 (19.1)	5/8 (15.9)
	300 (91)	7/8 (22.2)*	3/4 (19.1)
CR035RA	50 (15)	7/8 (22.2)	3/4 (19.1)

**Table 6.5 Liebert CRV Recommended Refrigerant Line Sizes, O.D. CU
for Liebert MC Condensers with and without Liebert® Lee Temp (continued)**

Liebert® CRV Model Number	Total Equivalent Length, ft (m)	Hot-gas Line, in. (mm)	Liquid Line, in. (mm)
	100 (30)	7/8 (22.2)	3/4 (19.1)
	150 (45)	7/8 (22.2)	3/4 (19.1)
	300 (91)	1-1/8 (28.6)*	7/8 (22.2)

Contact your Vertiv representative for line sizing for runs longer than 300 ft. (91.4 m) equivalent length.

*Must down-size vertical riser one trade size (1-1/8" to 7/8", 7/8" to 3/4", 3/4" to 5/8", 5/8" to 1/2").

Source: DPN000788, Rev. 16

**Table 6.6 Liebert® MC Condenser Piping Sizes for
60 mm (24 in.) and 300 mm (12 in.) units**

Model No.	Number of Fans	Connection Sizes, OD, in. (mm)	
		Hot Gas Line	Liquid Line
MCS028	1	7/8	5/8
MCM040	1	7/8	5/8
MCM080	2	1-1/8	7/8
MCL055	1	1-1/8	7/8
MCL110	2	1-3/8	1-1/8

Table 6.7 Single Circuit Liebert MC Condenser Piping Connection Sizes with Liebert® Lee-Temp for All Models of Liebert® CRV

Model #	Condenser Connections, OD, In		Liebert® Lee-Temp Connections		
	Hot Gas	Liquid	Hot Gas Tee IDS In.	Liquid Line to Lee-Temp Valve, ODS, In.	Receiver Out, IDS In.
MCS028	7/8	5/8	7/8	5/8	5/8
MCM040	7/8	5/8	7/8	5/8	5/8
MCM080	1-1/8	7/8	1-1/8	7/8	1-1/8
MCL055	1-1/8	7/8	1-1/8	7/8	7/8
MCL110	1-3/8	1-1/8	1-3/8	1-1/8	1-1/8

Source: DPN002167, Rev. 9

6.3.4 Refrigerant Charge Requirements for Air Cooled Systems

The following tables provide the refrigerant charge requirements for the Liebert® CRV, connected piping and condenser options.

Table 6.8 R410-A Refrigerant Charge for Air Cooled Liebert CRV

Model	Base Refrigerant Charge. lb (kg)
CR019RA	5 (2.7)
CR020RA	7 (3.2)
CR035RA	10 (4.5)

Table 6.9 Interconnecting Piping Refrigerant Charge for R-410A, lb per 100 ft (kg per 30 m)

Line Size, O.D., in.	Hot Gas lb/(kg)	Liquid lb/(kg)
3/8	—	3.2 (1.4)
1/2	0.7 (0.3)	5.9 (2.7)
5/8	1.1 (0.5)	9.6 (4.3)
3/4	1.6 (0.7)	14.3 (6.4)
7/8	2.3 (1.0)	19.8 (8.8)
1-1/8	3.9 (1.7)	33.8 (15.1)
1-3/8	5.9 (2.6)	51.5 (23.0)
1-5/8	8.4 (3.7)	—

Data based on 50°F Evap 15°F superheat 125°F SCT 10°F sub-cooling
Source: DPN003099 Rev. 1

Table 6.10 Liebert® MC Condenser Refrigerant Charge Approximate R-410A with and without Liebert® Lee-Temp

Single Circuit, lb/circuit (kg/circuit)		
Condenser Models	Condensers without Liebert® Lee-Temp	Condensers with Liebert® Lee-Temp
MCS028	2.5 (1.2)	21.7 (9.8)
MCM040	3.5 (1.6)	22.7 (10.3)
MCM080	8.5 (3.8)	39.8 (18.1)
MCL055	5.0 (2.3)	24.2 (11.0)
MCL110	10.7 (4.9)	49.1 (22.3)

Vacuum Refrigerant Charge Connection Locations

Figure 6.13 below, and Figure 6.14 on the next page, show the various connection locations for refrigerant charging.

Figure 6.13 Connections for Vacuum Creation and Refrigerant Charge—Air Cooled, 600°mm (24°in.)

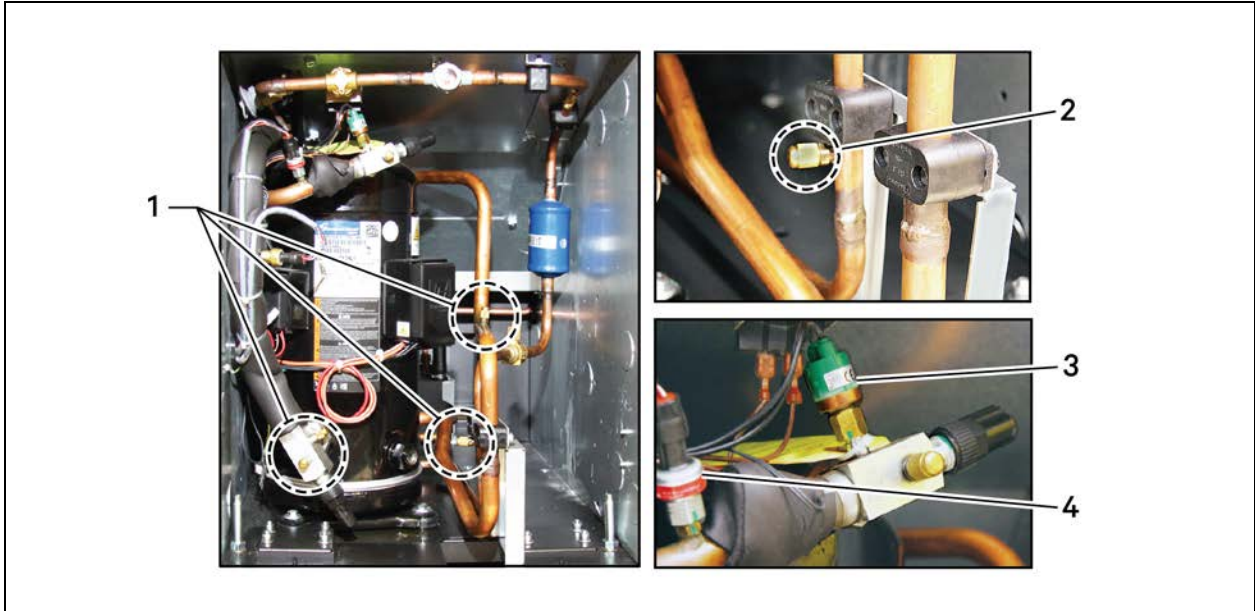

Item	Description
1	Suction, liquid, and discharge service connections
2	Liquid line service connection (close-up view of the center callout in Item 1)
3	High pressure switch
4	Pressure transducer

Figure 6.14 Connections for Vacuum Creation and Refrigerant Charge—Air Cooled, 300°mm (12°in.)

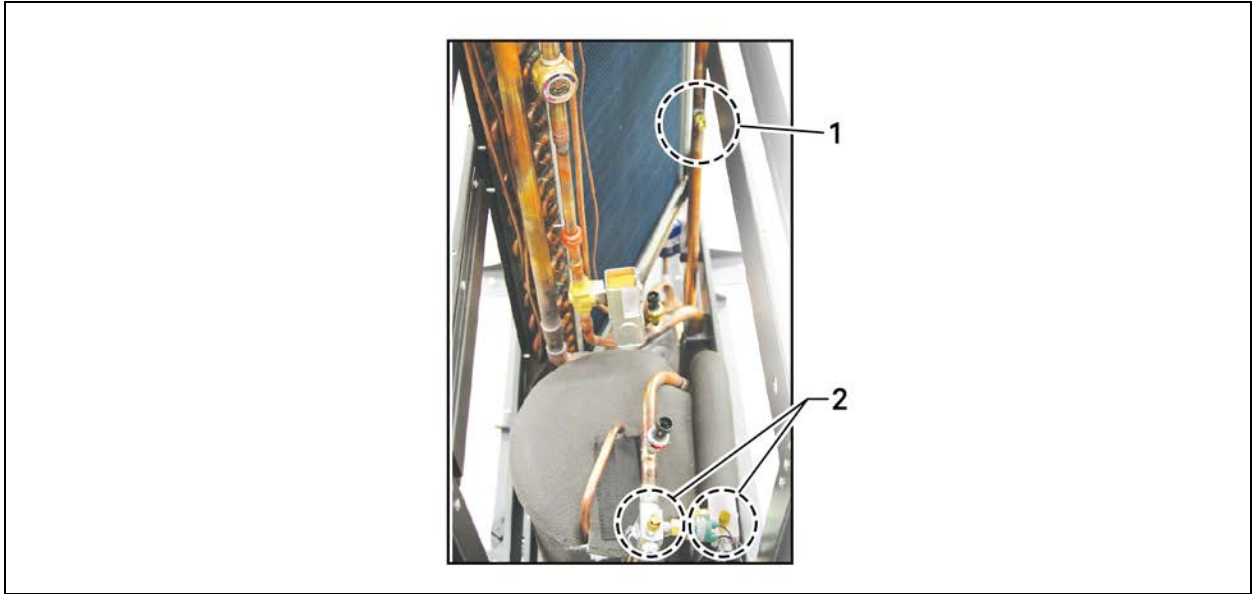

Item	Description
1	Service discharge connections for vacuum charging
2	Service suction and discharge connections for vacuum charging

6.3.5 Additional Oil Requirements for Digital Scroll Compressors

NOTICE

Risk of improper compressor lubrication. Can cause compressor and refrigerant system damage.

Failure to use oil types, viscosities and quantities recommended by the compressor manufacturer may reduce compressor life and void the compressor warranty. See **Table 6.12** on page 52 for the recommended oil for the system.

- Do not mix polyolester (POE) and mineral based oils.
- Do not mix oils of different viscosities.
- Consult your Vertiv sales representative, visit <https://www.Vertiv.com/en-us/support/>, or contact the compressor manufacturer if questions arise.

See **Table 6.11** on the facing page, for the amount required for various system charge levels.

In addition to oil added based on system charge, additional oil is required for discharge-line field installed traps. Standard-formed tube traps are required, see **Figure 6.15** on the facing page, and **Table 6.13** on page 52, because straight tubes and fittings used as traps require much more oil and the length of the straight tube can vary.

With the total calculated refrigerant charge for each circuit, see **Table 6.11** on the facing page for the refrigerant charge amount that was calculated and follow that line to the right to see how much additional compressor oil is required for each circuit.

Count the numbers of traps in each circuit. See **Table 6.13** on page 52 for the discharge line pipe diameter. Follow the line to the right to see how much oil is needed per trap. Multiply the number of traps per circuit by the Oil volume.

Add the additional compressor oil amount and the trap oil volume together. This will be the total amount of oil that will need to be added before the refrigerant is added to each circuit.

The amount of oil added by field service must be recorded on the tag marked “Oil Added Field Service Record,” attached to each compressor. The date of oil addition must be included as well.

Figure 6.15 Standard Formed Tube Trap Versus Straight Tubes and Fittings Trap

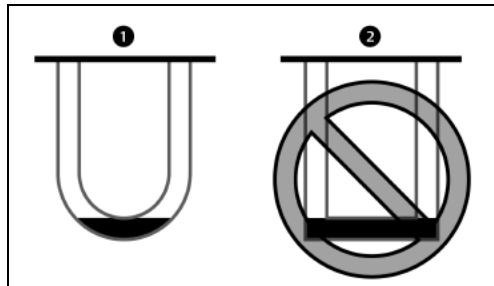

Item	Description
1	Standard-formed tube trap
2	Straight tubes and fittings trap

Table 6.11 Additional Oil Requirements Scroll and Digital Scroll

Refrigerant System Charge per Circuit, lb (kg) ¹	Model		
	CR019RA	CR020RA	CR035RA
	Additional Oil per Circuit oz (ml)		
<40 (18.1)	0	0	0
40 (18.1)	0	0	5 (150)
50 (22.7)	2 (60)	2 (60)	9 (270)
60 (27.2)	4 (120)	4 (120)	13 (380)
70 (31.8)	5.5 (160)	5.5 (160)	17 (500)
80 (36.3)	7 (210)	7 (210)	21 (620)
90 (40.8)	8.5 (250)	8.5 (250)	25 (740)
100 (45.4)	10 (300)	10 (300)	29 (860)

¹ System charge = Indoor unit + condenser + refrigerant receiver + refrigerant lines. For system charges over 100 lbs. (45.5 kg), consult your Vertiv representative.

Table 6.12 Compressor Oil Types for R-410A Refrigerant

Compressor Type	Oil Type for R-410A Refrigerant ²
Copeland Scroll and Digital Scroll	POE Oil ISO 32 Centistokes Viscosity
² Use Copeland POE oil ULTRA 32-3MAF or other Copeland-approved oils.	
Source: DPN003950 Rev. 6	

Table 6.13 Volume of Oil in Standard Form Trap by Pipe Diameter

Pipe diameter, in.	Oil volume, oz (ml)
1/2	0.2 (5.9)
5/8	0.4 (11.8)
3/4	0.6 (17.7)
7/8	0.9 (26.6)
1-1/8	1.8 (53.2)
1-3/8	3.3 (97.6)
1-5/8	5.5 (162.7)
Source: DPN003950, Rev. 6	

6.3.6 Evacuation, Leak Testing, and Charging Air Cooled Systems without Receivers

A discharge line and liquid line must be field installed between the indoor unit and the outdoor condenser. See the appropriate piping schematic, listed in [Piping General Arrangement Drawings](#) on page 27 .

Evacuation and Leak Testing Air Cooled Systems without Liebert®Lee-Temp Receiver

For proper leak check and evacuation, you must open all system valves and account for all check valves.

NOTE: The system includes a factory installed check valve and an additional downstream Schrader valve with core in the compressor discharge line. Proper evacuation of the condenser side of the compressor can be accomplished only using the downstream Schrader valve. See the appropriate piping schematic for your system in [Submittal Drawings](#).

1. If unit power is available, open the unit liquid line solenoid valve using the evacuation function in the diagnostic section of the Liebert® iCOM® control.
– or –
If unit power is not available, connect a field supplied 24-VAC/75-VA power source directly to the unit solenoid valve.
2. Connect a jumper hose from the service-valve fitting on the outlet of the receiver and the Schrader fitting on the discharge header of the condenser. Seat the service valve approximately two (2) turns from the fully back seated position.
3. At the compressor, connect refrigerant gauges to the suction rotalock valves and discharge line Schrader valves.
4. Open the service valves and place a 150 PSIG (1034 kPa) charge of dry nitrogen with a tracer of refrigerant. Check system for leaks with a suitable leak detector.

5. After completion of leak testing, release the test pressure, (observe local code) and pull an initial deep vacuum of 500 microns on the system with a suitable pump.
6. After 4 hours, check the pressure readings and, if they have not changed, break vacuum with dry nitrogen. Pull a second and third vacuum to 500 microns or less. Re-check the pressure after 2 hours.

When the 3 checks are complete, remove the jumper hose from the service-valve fitting and the condenser, and proceed to [Charging Air Cooled Systems with Liebert® Lee-Temp Receiver](#) on page 59 .

Breaking Vacuum

Using a manifold charging hose equipped with a ball valve, properly connect to a tank of refrigerant, and purge the hose with refrigerant to ensure non-condensables do not enter the system. Connect the hose assembly to the liquid line Schrader port and break circuit vacuum with a portion of the calculated refrigerant pre-charge. Add enough refrigerant to bring pressure slightly above positive. Close ball valve and remove refrigerant tank.

Charging Air Cooled Systems without Liebert® Lee-Temp

NOTICE

Risk of improper refrigerant charging. Can cause equipment damage.

R-410A is a blended refrigerant and must be introduced and charged from the cylinder only as a liquid.

Care must be exercised to avoid damage to the compressor. We recommend connecting a manifold charging hose equipped with a ball valve to the liquid line Schraeder port.

NOTICE

Risk of refrigerant overcharge. Can cause equipment damage.

Do not use the sight glass as an indicator when charging Liebert® condenser systems.

NOTE: A digital scroll compressor can have a clear unit sight glass on the liquid line only when operating at 100% capacity. When operating below 100%, the unit sight glass may show bubbles with each 15-second unloading cycle.

The system must be fully piped and evacuated before it can be charged. See [Evacuation and Leak Testing Air Cooled Systems without Liebert® Lee-Temp](#).

Liebert® MC condensers are charge sensitive and require accurate calculation of the system charge to avoid overcharging. To avoid overcharge, the following additional guidelines are recommended to ensure trouble-free operation.

- When charging system in an outdoor ambient below 50°F (10°C), recheck the subcooling against **Table 6.14** on page 56, when the ambient is above 60°F (15.6°C)
- The indoor space should be maintained at 70 to 80°F (21 to 26.7°C) return air before final charge adjustments are made.
- Charging unit at greater than 80°F (26.7°C) return air and low outdoor ambient temperature may result in the unit being overcharged.
- Charge by subcooling measurement at the indoor unit. See **Table 6.14** on page 56, for target subcooling temperatures.
- Pressure and temperature measuring instruments should be capable of measuring to ±10 psig (68.9 kPa) and ±2°F (1.1°C) for best subcooling measurement.

NOTICE

Units should never be operated with no refrigerant charge, holding charge, proper load, or without additional oil as required. Tag out system to prevent unauthorized personnel from accidentally starting equipment and damaging compressors if any of these conditions exist.

To charge the system:

1. Check the nameplate on the indoor unit for refrigerant type to be used. Unit control configurations differ depending on refrigerant type.
2. Refer to the following if necessary:
 - [Checks to Perform after Start-up](#) to operate the system.
 - The operating manual for the Liebert® MC Condenser.

Manuals are available at <https://www.Vertiv.com/en-us/support/>.

3. Calculate the amount of charge for the system. See [Refrigerant Charge Requirements for Air Cooled Systems](#) on page 48 .
4. Add additional compressor and trap oil. See section [Additional Oil Requirements for Digital Scroll Compressors](#) on page 50 .
5. Accurately weigh in as much of the system charge as possible before starting the unit. Do not exceed the calculated charge by more than 0.5 lb (0.23 kg).
6. Close the Liebert® MC disconnect switch.
7. Close the Liebert® CRV disconnect switch.

NOTICE

The unit must have line voltage applied to the unit at least 12 hours before compressor start-up to allow the compressor crankcase heaters time to warm the compressors and boil off any liquid refrigerant in the compressors after pre-charge.

8. In the Service menu of the Liebert® iCOM controller, select *Diagnostics/Service > Diagnostics*:
 - a. *Enable Manual Mode*.

NOTE: Manual Mode will time out after 60 minutes.

- b. In Evaporator Fan options set *Motors* to *On* to operate the fan during Manual Mode.
- c. In Compressor Circuit 1 options, set *Compressor Mode* to *Charge* to operate the compressor at full capacity, energize the liquid line solenoid valve, and disable reheat and humidifier.
- d. Reset the charge function as many times as needed to complete unit charging.

NOTE: You must establish and maintain a minimum 20 psig (138 kPa) for the compressor to operate.

9. Attach pressure and temperature instruments to the liquid line of the indoor unit, measure the initial subcooling, and continue to add charge until the recommended subcooling for the current outdoor ambient temperature is reached. See **Table 6.14** on the next page . Read the outdoor ambient temperature from the Liebert® MC condenser control menu ID F02.

NOTE: To determine subcooling measurement, you must measure the liquid line pressure reading (at the factory installed Schrader tap) and obtain a temperature reading on the liquid line. Convert the liquid line pressure reading into a liquid temperature using a Pressure Temperature Guide or Table 6.15 on page 57 . Subtract the measured temperature from the saturated-liquid temperature. The difference is subcooling. Make sure to use the saturated liquid temperature to calculate subcooling.

10. As head pressure builds, the variable fan speed controlled condenser fan begins rotating. The fan will run at full speed when sufficient head pressure is developed.

Additional Compressor Oil

Once the circuits are topped off with refrigerant, more compressor oil may need to be added to each circuit if the final charge is over 10 pounds of the calculated refrigerant charge. Record this additional oil amount on the manilla tag hanging on the compressor service valve.

Table 6.14 Target Subcooling for Ambient Outdoor Temperature

Ambient Temp, °F (°C)	Subcooling, °F (°C)
0 (-17.8)	22 (12.0)
10 (-12.2)	22 (12.0)
20 (-6.7)	22 (12.0)
30 (-1.1)	22 (12.0)
40 (4.4)	22 (12.0)
50 (10.0)	21 (11.7)
60 (15.6)	19 (10.8)
70 (21.1)	17 (9.3)
80 (26.7)	13 (7.2)
90 (32.2)	9 (5.0)
95 (35.0)	7 (3.9)
100 (37.8)	5 (2.9)
105 (40.6)	3 (1.8)
110 (43.3)	1 (0.7)
125 (51.7)	0

DPN002411, Rev. 8

Table 6.15 Liquid Pressure and Temperature Chart—R-410A

Pressure		Temperature*	
PSIG	BarG	°F	°C
170	11.7	59.8	15.4
180	12.4	63.1	17.3
190	13.1	66.3	19.1
200	13.8	69.5	20.8
210	14.5	72.5	22.5
220	15.2	75.4	24.1
230	15.9	78.2	25.7
240	16.6	80.9	27.2
250	17.2	83.6	28.7
260	17.9	86.2	30.1
270	18.6	88.7	31.5
280	19.3	91.1	32.8
290	20.0	93.5	34.2
300	20.7	95.8	35.5
310	21.4	98.1	36.7
320	22.1	100.3	38.0
330	22.8	102.5	39.2
340	23.4	104.6	40.3
350	24.1	106.7	41.5
360	24.8	108.7	42.6
370	25.5	110.7	43.7
380	26.2	112.7	44.8
390	26.9	114.5	45.9
400	27.6	116.4	46.9
500	34.5	133.5	56.4
600	41.4	148.1	64.5

* Values are for saturated liquid
Source: DPN002411, Rev. 8

6.3.7 Evacuation, Leak Testing, and Charging Air Cooled Systems with Liebert® Lee-Temp Flooded Condenser Head Pressure Control System

The Liebert® Lee-Temp system consists of a modulating-type head-pressure control valve and insulated receiver with heater pad to ensure operation at ambient temperatures as low as -30°F (-34.4°C). The Liebert® Lee-Temp system can be used with any compressor or expansion-valve choice.

A discharge line and liquid line must be field installed between the indoor unit and the outdoor condenser. See the appropriate piping schematic, listed in **Table 6.1** on page 27.

Liebert® Lee-Temp Controlled Materials Supplied

- Built-in, pre-wired condenser control box
- Air-cooled condenser
- Piping access cover
- Bolts—4 per leg (3/8 in. x 5/8 in.)
- Terminal block for 2 wire, 24 V interlock connection between unit and condenser
- Terminal blocks for shielded, CANbus cable connection between unit and condenser
- Condenser legs—4 with one fan unit and 5 with two fan units
- Bolts—6 per receiver (3/8 in. x 1 in.)
- Liebert® Lee-Temp system:
 - Insulated storage receiver with 2 liquid level sight glasses—1 per circuit
 - Head pressure control valve piping assembly with 2 integral check valves—1 per circuit
 - Service valve—1 per receiver
 - Pressure relief valve—1 per receiver

NOTE: The Liebert® Lee-Temp heater pad requires a separate, continuous electrical source. See nameplate on receiver for proper voltage.

Breaking Vacuum

Using a manifold charging hose equipped with a ball valve, properly connect to a tank of refrigerant, and purge the hose with refrigerant to ensure non-condensables do not enter the system. Connect the hose assembly to the liquid line Schrader port and break circuit vacuum with a portion of the calculated refrigerant pre-charge. Add enough refrigerant to bring pressure slightly above positive. Close ball valve and remove refrigerant tank.

Charging Air Cooled Systems with Liebert® Lee-Temp Receiver

NOTICE

Risk of improper refrigerant charging. Can cause equipment damage.

R-410A is a blended refrigerant and must be introduced and charged from the cylinder only as a liquid.

Care must be exercised to avoid damage to the compressor. We recommend connecting a manifold charging hose equipped with a ball valve to the liquid line Schraeder port.

NOTICE

Risk of improper operation. Can cause compressor failure.

Operating the unit with the EEV closed can cause compressor failure. The reheat and humidifier are disabled. A minimum of 20 psig (138 kPa) must be established and maintained for the compressor to operate. The charging function can be reset as many times as required to complete.

NOTICE

Units should never be operated with no refrigerant charge, holding charge, proper load, or without additional oil as required. Tag out system to prevent unauthorized personnel from accidentally starting equipment and damaging compressors if any of these conditions exist.

To charge the system:

1. Check the nameplate on the indoor unit for refrigerant type to be used. Unit control configurations differ depending on refrigerant type.
2. Calculate the amount of charge for the system. See [Refrigerant Charge Requirements for Air Cooled Systems](#) on page 48.
3. Add additional compressor and trap oil. See [Additional Oil Requirements for Digital Scroll Compressors](#) on page 50.
4. Accurately weigh in as much of the system charge as possible before starting the unit.
5. Close the Liebert® CRV disconnect switch.

NOTICE

The unit must have line voltage applied to the unit at least 12 hours before compressor start-up to allow the compressor crankcase heaters time to warm the compressors and boil off any liquid refrigerant in the compressors after pre-charge.

6. In the Service menu of the Liebert® iCOM controller, select *Diagnostics/Service > Diagnostics*:
 - a. *Enable Manual Mode*.

NOTE: Manual Mode will time out after 60 minutes.

- b. In Evaporator Fan options set *Motors* to *On* to operate the fan during Manual Mode.
- c. In Compressor Circuit 1 options, set *Compressor Mode* to *Charge* to operate the compressor at full capacity, energize the liquid line solenoid valve, and disable reheat and humidifier.
- d. Reset the charge function as many times as needed to complete unit charging.

NOTE: You must establish and maintain a minimum 20 psig (138 kPa) for the compressor to operate.

7. Check the refrigerant level in the refrigerant-level sight glass on the Lee-Temp receiver after the unit has been operating for at least 15 minutes.

NOTE: The receiver at the condenser has 2 sight glasses and the refrigerant level varies with outside temperature.

8. Adjust the refrigerant level to meet the level shown in [Target Refrigerant Level in Sight Glasses at Outdoor Temperatures](#) below .
9. After adjusting the refrigerant, allow the system to operate an additional 15 minutes before checking for the need of further adjustment.

NOTE: A digital scroll compressor can have a clear unit sight glass on the liquid line only when operating at 100% capacity. When operating with a receiver, the unit sight glass might not become clear even when operating at 100% capacity. When operating below 100%, the unit sight glass may show bubbles with each 15 second unloading cycle.

Target Refrigerant Level in Sight Glasses at Outdoor Temperatures

- 40°F (4.5°C) and lower—bottom sight glass is 3/4 full
- 40 to 60°F (4.5 to 15.5°C)—bottom sight glass is full
- 60°F (15.5°C) and higher—top sight glass is 3/4 full

Additional Compressor Oil

Once the circuits are topped off with refrigerant, more compressor oil may need to be added to each circuit if the final charge is over 10 pounds of the calculated refrigerant charge. Record this additional oil amount on the manilla tag hanging on the compressor service valve.

6.3.8 Superheat and Refrigerant Charge Optimization

Superheat on All Units

Compressor suction superheat for all unit types should be checked and adjusted per **Table 6.17** on the facing page . See [Determining Suction Superheat](#) on page 104 and [Adjusting Superheat Setting with the TXV](#) on page 105 for superheat measurement and adjustment methods.

Optimizing Refrigerant Charge on Water/Glycol Units

Liebert® CRV water/glycol systems are factory charged with R-410A refrigerant and will operate without refrigerant charge adjustment at a wide range of return air temperatures and water/glycol entering temperatures. Adjusting the factory refrigerant charge while operating the unit at full-load room conditions and at typical water/glycol temperatures can maximize the cooling capacity and unit efficiency.

Table 6.16 on the facing page , describes the factory charge for the unit.

Table 6.16 R410-A Refrigerant Factory Charge and Oil Charge for Water Cooled Liebert® CRV

Model	R-410A Refrigerant Charge, lb (kg)	Initial Oil Charge, oz. (kg)*
CR019RW	6.5 (2.9)	60 (1.68)
CR020RW	13.0 (5.9)	60 (1.68)
CR035RW	17.0 (7.7)	110 (3.12)

1. Use Copeland POE Oil ULTRA 32-3MAF or other Copeland approved oils.

To optimize the refrigerant charge:

- Operate the unit at full heat load, normal room conditions and normal water/glycol fluid temperatures for a minimum of 30 minutes before measuring stable unit superheat and subcooling temperatures and adjusting charge levels.
 - Condensing temperatures should be in range of 100 to 130°F (38 to 54°C) depending on fluid type and fluid temperature.
 - Full heat load is required to stabilize the system and prevent digital scroll-compressors from modulating.
- Attach pressure and temperature instruments to the liquid line of the indoor unit. Use the factory installed Schrader valve located in the liquid line downstream of the condenser. Measure the initial subcooling.

NOTE: To determine subcooling measurement, a liquid line pressure reading (at the factory installed Schrader tap) must be measured along with the temperature reading on the liquid line. Convert the liquid line pressure reading into a liquid temperature by utilizing a Pressure-temperature Guide or Table 6.15 on page 57. Subtract the measured temperature from the liquid-saturation temperature. The difference is subcooling.

- Adjust refrigerant charge levels as needed to achieve subcooling and superheat ranges shown for your model in Table 6.17 below, while maintaining full load conditions.

Table 6.17 Target Superheat and Subcooling Ranges by Model Number

Model No.	Model Width	System Type	Superheat	Subcooling
CR019	12 in. (300 mm)	Air-cooled	10 – 20°F (5.6 – 11.1°C)	See Table 6.14 on page 56.
		Water/Glycol-cooled	15 – 25°F (8.3 – 13.9°C)	1 – 5°F (0.6 – 2.7°C)
CR020 CR035	24 in. (600 mm)	Air-cooled	10 – 20°F (5.6 – 11.1°C)	See Table 6.14 on page 56.
		Water/Glycol-cooled	10 – 20°F (5.6 – 11.1°C)	1 – 5°F (0.6 – 2.7°C)

6.4 Water/Glycol Loop Piping Guidelines

NOTICE

Risk of frozen pipes and corrosion from improper coolant mixture. Can cause water leaks resulting in equipment and building damage.

When the cooling unit or piping may be exposed to freezing temperatures, charge the system with the proper percentage of glycol and water for the coldest design ambient temperature. Automotive antifreeze is unacceptable and must NOT be used in any glycol fluid system. Use only HVAC glycol solution that meets the requirements of recommended industry practices.

NOTICE

Risk of piping system corrosion and freezing fluids. Can cause leaks resulting in equipment and very expensive building damage. Cooling coils, heat exchangers and piping systems are at high risk of freezing and premature corrosion. Fluids in these systems must contain the proper antifreeze and inhibitors to prevent freezing and premature coil, heat exchanger and piping corrosion. The water or water/glycol solution must be analyzed by a competent local water treatment specialist before start up to establish the inhibitor and antifreeze solution requirement and at regularly scheduled intervals throughout the life of the system to determine the pattern of inhibitor depletion.

The complexity of water/glycol solution condition problems and the variations of required treatment programs make it extremely important to obtain the advice of a competent and experienced water treatment specialist and follow a regularly scheduled coolant fluid system maintenance program.

Water chemistry varies greatly by location, as do the required additives, called inhibitors, that reduce the corrosive effect of the fluids on the piping systems and components. The chemistry of the water used must be considered, because water from some sources may contain corrosive elements that reduce the effectiveness of the inhibited formulation. Sediment deposits prevent the formation of a protective oxide layer on the inside of the coolant system components and piping. The water/coolant fluid must be treated and circulating through the system continuously to prevent the buildup of sediment deposits and or growth of sulfate reducing bacteria.

Proper inhibitor maintenance must be performed in order to prevent corrosion of the system. Consult glycol manufacturer for testing and maintenance of inhibitors.

Commercial ethylene glycol, when pure, is generally less corrosive to the common metals of construction than water itself. It will, however, assume the corrosivity of the water from which it is prepared and may become increasingly corrosive with use if not properly inhibited.

We recommend installing a monitored fluid detection system that is wired to activate the automatic closure of field installed coolant fluid supply and return shutoff valves to reduce the amount of coolant-fluid leakage and consequential equipment and building damage. The shutoff valves must be sized to close off against the maximum coolant fluid system pressure in case of a catastrophic fluid leak.

NOTICE

Risk of no flow condition. Can cause equipment damage.

Do not leave the water/coolant fluid supply circuit in a no flow condition. Idle fluid allows the collection of sediment that prevents the formation of a protective oxide layer on the inside of tubes. Keep unit switched On and water/coolant fluid-supply circuit system operating continuously.

- Use copper piping with a brazing alloy with a minimum temperature of 1350°F (732°C), such as Sil-Fos. Avoid soft solders, such as 50/50 or 95/5.
- Follow local piping codes and safety codes.
- Qualified personnel must install and inspect system piping.

- The water/glycol cooled system will operate in conjunction with a cooling tower, city water or drycooler.
- Contact a local water consultant regarding water quality, corrosion protection and freeze protection requirements.
- Install manual shut off valves at the supply and return line to each unit and drycooler to permit routine service and emergency isolation of the unit.
- Install a monitored, fluid detection system that is wired to activate the automatic closure of field installed coolant fluid supply and return shut off valves to reduce the amount of coolant fluid leakage and consequential equipment and building damage. The shut off valves must be sized to close off against the maximum coolant-fluid system pressure in case of a catastrophic fluid leak.

6.4.1 Glycol Mixture

Add ethylene glycol or propylene glycol to the circuit in the percentages shown in the following table.

Table 6.18 Glycol Mixtures

Glycol Percentage * by Volume	Ethylene Glycol - Freezing Temperature, °F (°C)	Propylene Glycol - Freezing Temperature, °F (°C)
0%	32 (0)	32 (0)
10%	25.3 (-3.7)	28.9 (-1.7)
20%	16 (-8.9)	18.7 (-7.4)
30%	3.7 (-15.7)	8.4 (-13.1)
40%	-12.6 (-24.8)	-6.7 (-21.5)

* Freezing temperatures may vary slightly among commercially available glycol products; refer to manufacturer's specifications.

6.4.2 Water/Glycol Cooled Piping Connections

- The unit must receive cooling water via:
 - Open circuit, see [Open Circuit Applications](#) below , for additional requirements.
 - or –
 - Closed circuit, see [Closed Circuit Applications](#) below , for additional requirements.
- Connect the refrigerant piping as described in [Piping and Refrigerant Requirements](#) on page 27 .
- Use hoses connected with 3 piece joints to the condenser water inlet and outlet couplings.
- Install a field supplied, 16-20 mesh strainer on the water/glycol supply to the indoor unit. The strainer prevents particles in the water from entering the unit's heat exchanger.
- Place shutoff ball valves at the indoor unit inlet and outlet to allow easy maintenance.
- Install a water drain system at the lowest point in the circuit.
- Fully drain the piping before connecting it to the cooling unit.

Open Circuit Applications

The cooling unit receives cooling water in an open circuit from an external cooling water source. For open circuit applications note the following:

- Use the unit with mains or well water. Do not use water from an evaporative cooling tower unless the water hardness is controlled.
- The water pressure must be 29 to 145 psi (2 to 10 bar). If water pressure is outside this range, contact Vertiv for technical support.
- The required water flow at different temperatures is available from Vertiv technical support.
- If water temperature is very low, insulate both pipes.

Closed Circuit Applications

The cooling unit receives cooling water in a closed circuit using a drycooler. For closed circuit applications, note the following:

- Install a pump system calculated on the basis of the flow and total head of the system (see site plan data) and controlled by the compressor running (see label on the unit).
- Insulate both pipes.

IMPORTANT! Add water and ethylene or propylene glycol to the circuit when the ambient temperature is below 32°F (0°C). Refer to the Liebert® CRV System Design Manual, SL-11978). Do not exceed the nominal operating pressure of the circuit components.

- Bleed air out of the circuit.
- The following figure shows the recommended installation of a drycooler.

Figure 6.16 Recommended Drycooler Installation

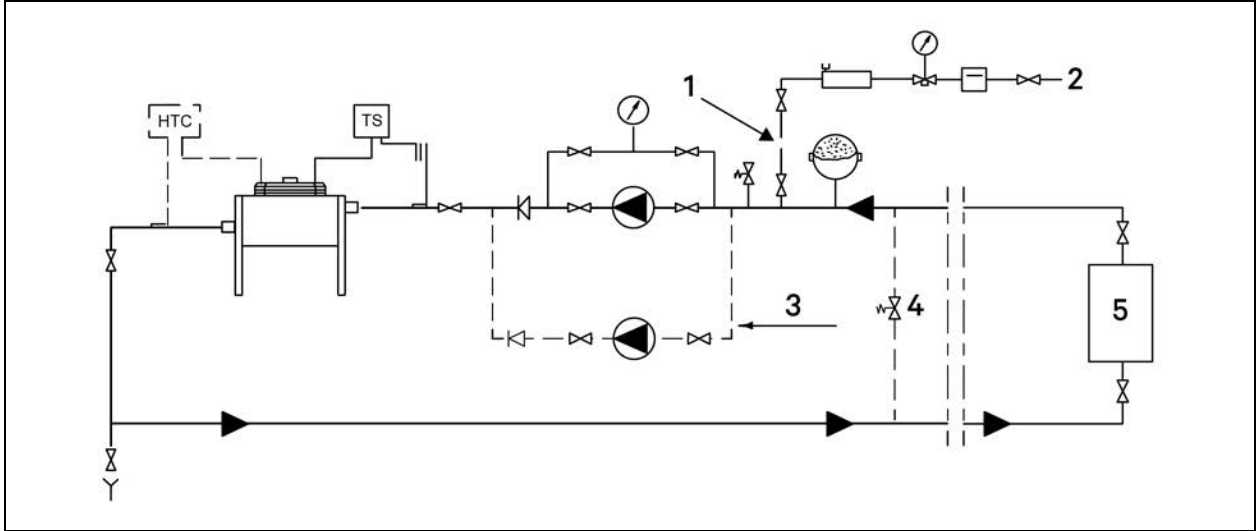

Item	Description	Item	Description
1	Disconnect after charge.		Expansion tank
2	Fill water		Filling meter
3	Stand-by pump (optional)		Gauge
4	Pressure-operated bypass		Pump
5	Thermal-management unit		Safety valve
	Air separator		Shut off valve
	Charge group (filter, reducer, check valve)	TS	Thermostat
	Check valve	HTC	Variex
Y	Drain (at lowest point)		

6.4.3 Leak Checking for Unit and Field Installed Piping

The fluid systems in the Liebert® CRV are factory-checked for leaks and may be shipped with a nitrogen holding charge. At installation, check all fluid circuits for leaks.

NOTE: We recommend isolating the unit with field-installed shutoff valves during leak checking of field-installed piping. When the units are included in a leak test, use of fluid for pressure testing is recommended. When pressurized gas is used for leak testing the unit, the maximum recommended pressure is 30 psig (207 kPa) and tightness of the unit should be verified by pressure decay over time, (<2 psig/hour [13.8 kPa/hour]) or sensing a tracer gas with suitable instrumentation. Dry seals in fluid valves and pumps may not hold a high gas pressure.

Table 6.19 Fluid Systems

Liebert® CRV Option	Condensate Pump and Humidifier r		Condensate Pump and No Humidifie		No condensate Pump and No Humidifier	
Model	600 mm	300 mm	600 mm	300 mm	600 mm	300 mm
Top Connections	Available	Not available	Available	Available	Not Available	Available
Bottom Connections	Available	Not Available	Available	Available	Not Available	Available

Table 6.20 Volume of Internal Water Circuits—600 mm (24 in) and 300 mm (12 in)

Model	Volu, gal. (L)
CRO19RW	1.0 (3.78)
CRO20RW	1.50 (5.7)
CRO35RW	1.51 (5.7)

6.5 Chilled Water Loop Piping

For the top connection locations the, refer to the appropriate submittal documents included in the [Submittal Drawings](#) on page 131. **Figure 6.17** on the facing page shows the bottom connection locations for the chilled-water units. **Figure 6.18** on page 68 diagrams the chilled-water circuit.

- Use copper tubing or steel pipe.

NOTE: A dielectric fitting is required when using steel pipe.

- Place the tubing on supporting saddles.
- Insulate both tubes.
- Install shut off ball valves on the inlet and outlet pipes to ease maintenance.
- Install optional thermostats and pressure gauges on the inlet and outlet pipes.
- Install a water drain tap at the lowest point in the circuit.
- Fill the circuit with water or glycol.
- Locate air vents at tops of all risers and any intermediate system high points.

Figure 6.17 Bottom Connections on Chilled Water Units

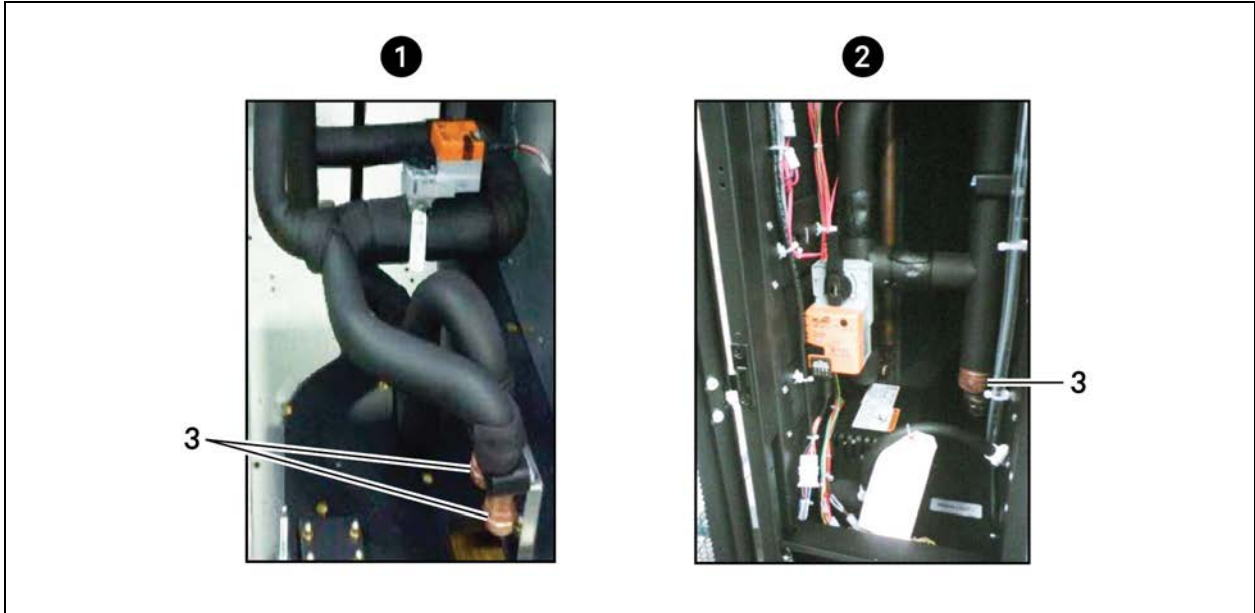

Item	Description
1	600 mm (24 in.) unit
2	300 mm (12 in.) unit
3	Chilled water connections

Figure 6.18 Chilled Water Circuit

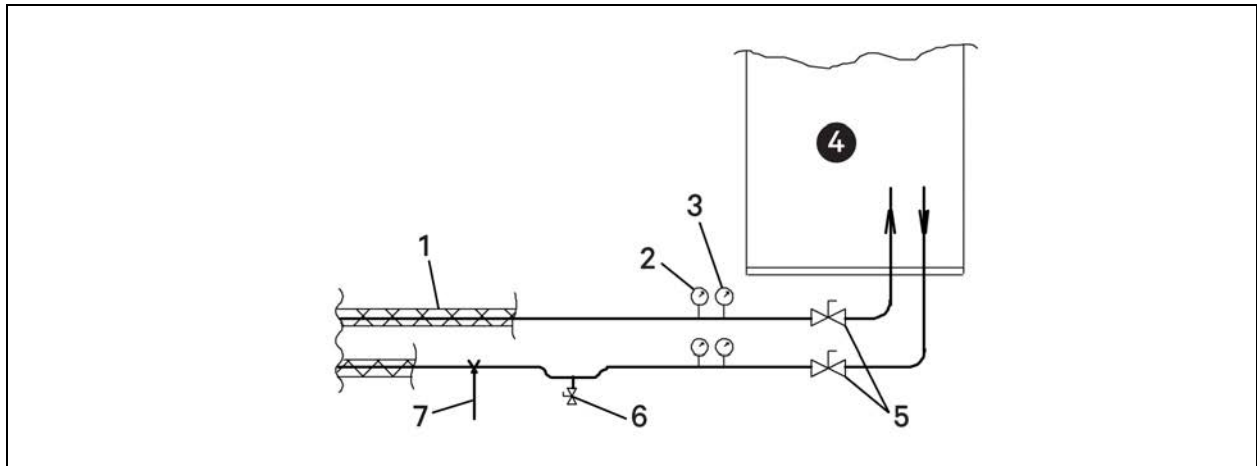

Item	Description	Item	Description
1	Insulation	5	Ball valve
2	Thermostat	6	Water drain trap
3	Pressure gauge	7	Tubing support
4	Liebert® CRV		

Figure 6.19 Venting Air Trapped in a Chilled Water Unit

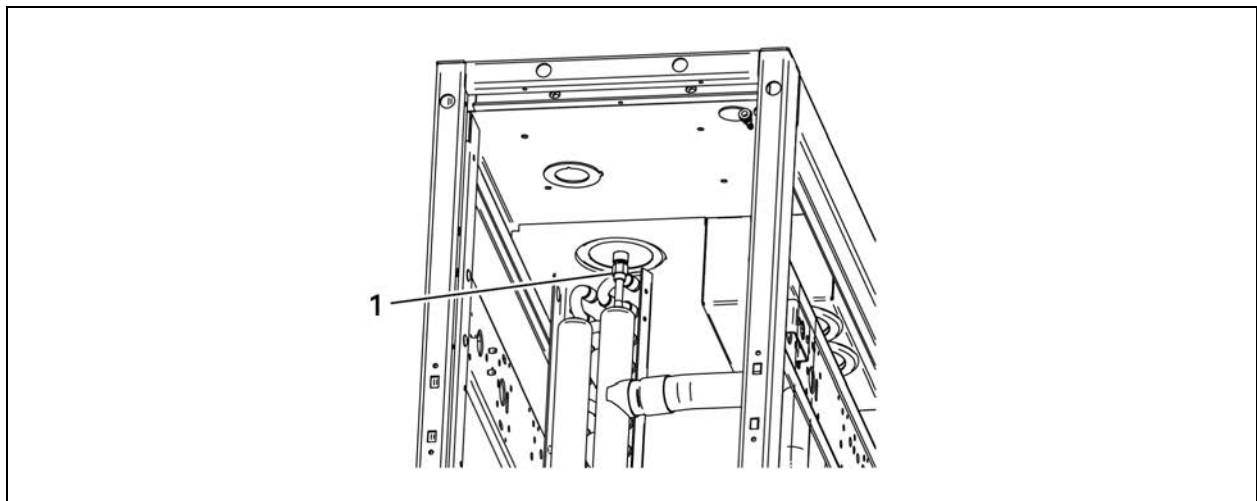

Item	Description
1	Schrader valve on core

7 Electrical Connections



WARNING! Arc flash and electric shock hazard. Open all local and remote electric power-supply disconnect switches, verify with a voltmeter that power is Off and wear appropriate, OSHA-approved personal protective equipment (PPE) per NFPA 70E before working within the electric control enclosure. Failure to comply can cause serious injury or death. Customer must provide earth ground to unit, per NEC, CEC and local codes, as applicable. Before proceeding with installation, read all instructions, verify that all the parts are included and check the nameplate to be sure the voltage matches available utility power. The Liebert® controller does not isolate power from the unit, even in the “Unit Off” mode. Some internal components require and receive power even during the “Unit Off” mode of the controller. The only way to ensure that there is NO voltage inside the unit is to install and open a remote disconnect switch. Refer to unit electrical schematic. Follow all local codes.

Installation, service, and maintenance work must be performed only by properly trained and qualified personnel and in accordance with applicable regulations and manufacturers’ specifications. Opening or removing the covers to any equipment may expose personnel to lethal voltages within the unit even when it is apparently not operating and the input wiring is disconnected from the electrical source.



WARNING! Risk of electric shock. Can cause equipment damage, injury or death. Open all local and remote electric power supply disconnect switches and verify with a voltmeter that power is off before working within any electric connection enclosures. Service and maintenance work must be performed only by properly trained and qualified personnel and in accordance with applicable regulations and manufacturers’ specifications. Opening or removing the covers to any equipment may expose personnel to lethal voltages within the unit even when it is apparently not operating and the input wiring is disconnected from the electrical source.

Before proceeding with the electrical connections, ensure that:

- All electrical components are undamaged
- All terminal screws are tight
- The supply voltage and frequency are as indicated on the unit

NOTE: The serial tag on the 600 mm (24 in.) unit is on the inside of the display panel. The serial tag on the 300°mm (12 in.) unit is on the narrow side of the electric panel, nearest the filters.

7.1 Power Supply Cable Connection Guidelines

- Connect the cable to the line inlet terminal board.
- Use the appropriate cable size for the current draw, supply voltage and installation type.
- Protect the supply using a backup fuse or circuit breaker.
- Do not fit the supply cable in the raceways inside the unit’s electric board—600 mm (24 in.) units.
- Use only multi-polar cables with sheath (CEI20-22).

7.2 Wiring Connection Guidelines

- Remote On/Off connections must be provided by the installer.
- The General Alarm terminals allow remote alarm signaling.

In case of short circuit, check the affected switch for sticking and replace it if necessary.

7.3 Electrical Field Connections Descriptions

The electrical connections are described in the submittal documents included in the [Submittal Drawings](#) on page 131.

The following table lists the relevant documents by number and title.

Table 7.1 Electrical Field Connection Drawings

Document Number	Title
600 mm (24 in.) Models	
DPN001884	Electrical Field Connections Descriptions, 600 mm (24 in.) Models
DPN002841	CANbus & Interlock Connections between 600 mm (24 in.) Unit & Liebert® MC Condenser
300 mm (12 in.) Models	
DPN002810	Electrical Field Connections Descriptions, 300 mm (12 in.) Models
DPN003036	CANbus & Interlock Connections between 300 mm (12 in.) Unit & Liebert® MC (Premium)
DPN003588	Low Voltage Field Wiring Routing, 300 mm (12 in.) All Models
DPN003589	Power Cable Routing Bottom Entry, 300 mm (12 in.) Air Cooled & Water Glycol Cooled Models
DPN003590	Power Cable Routing Bottom Entry 300 mm (12 in.) Chilled Water Models

7.3.1 Locating the Serial Tags and Removing the Electrical Panel on 600 mm (24 in.) Units

This serial tag on the 600 mm (24-in.) unit is inside the display panel as shown in [Serial Tag Location—600 mm \(24 in.\)](#) on the facing page.

Figure 7.1 Serial Tag Location—600 mm (24 in.)

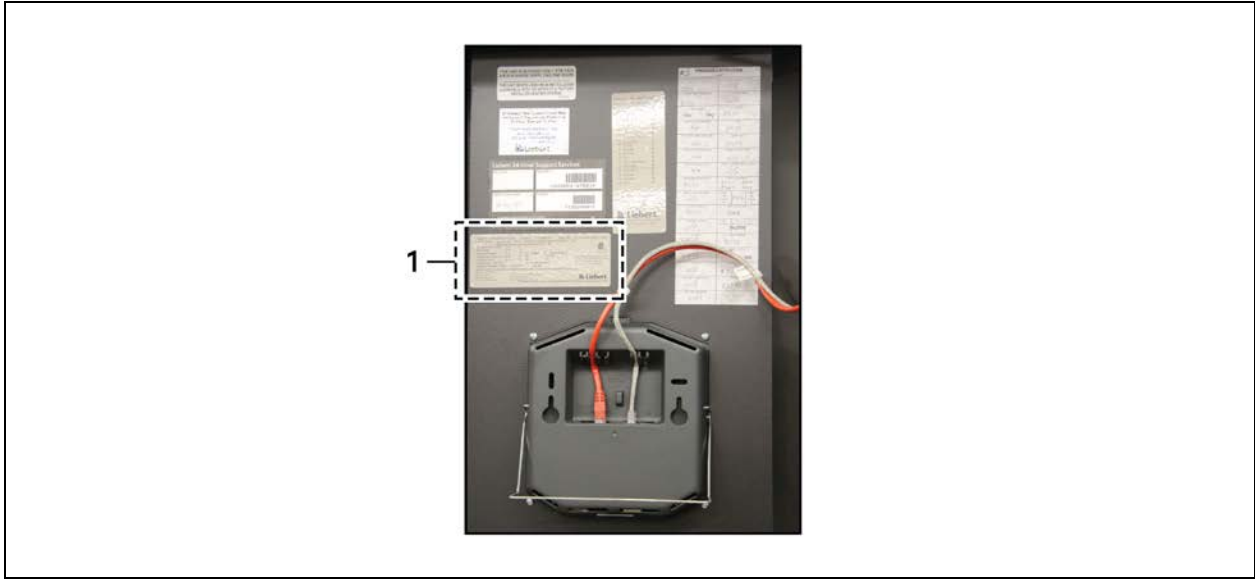

Item	Description
1	Serial tag

To access the electrical panels:

Refer to [Remove Electrical Panel and Lower Front Panel—600 mm \(24 in.\)](#) below , and remove the bolts indicated.

Figure 7.2 Remove Electrical Panel and Lower Front Panel—600 mm (24 in.)

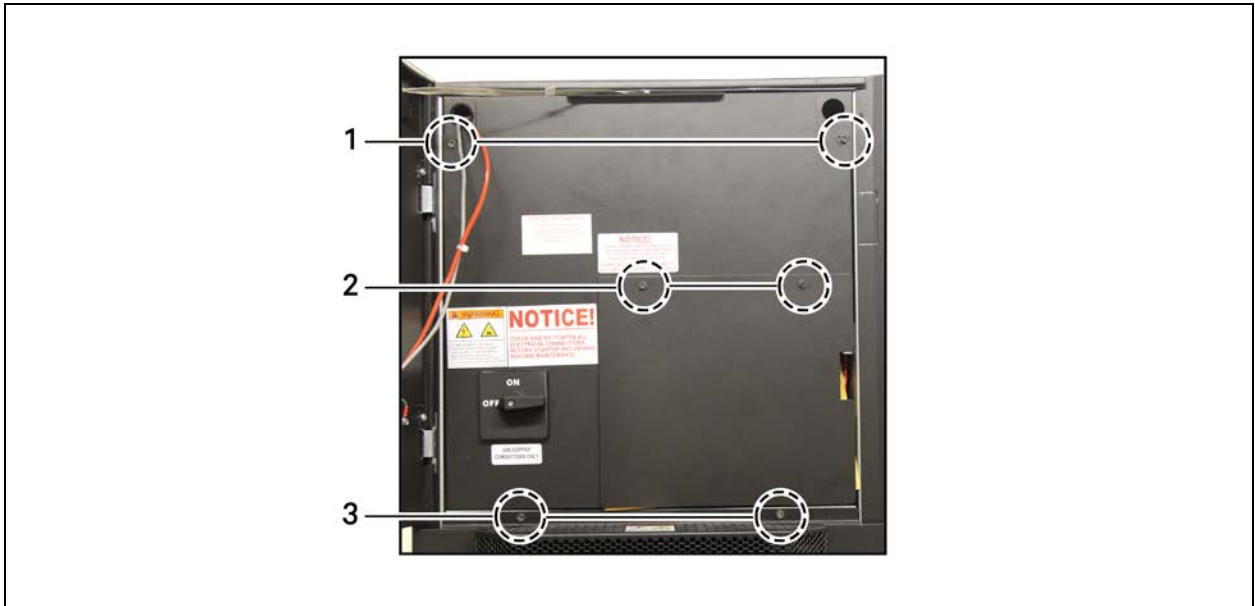

Item	Description
1	Bolts to remove for access to high voltage electrical panel
2	Bolts to remove for access to low voltage electrical panel
3	Bolts to remove to open lower front-baffle panel

7.3.2 Cable Entry Points on 600 mm (24 in.) Units

Figure 7.3 below shows the high and low voltage cable-entry points.

Figure 7.3 Power and Control Cable Entry Points and Routing—600 mm (24 in.)

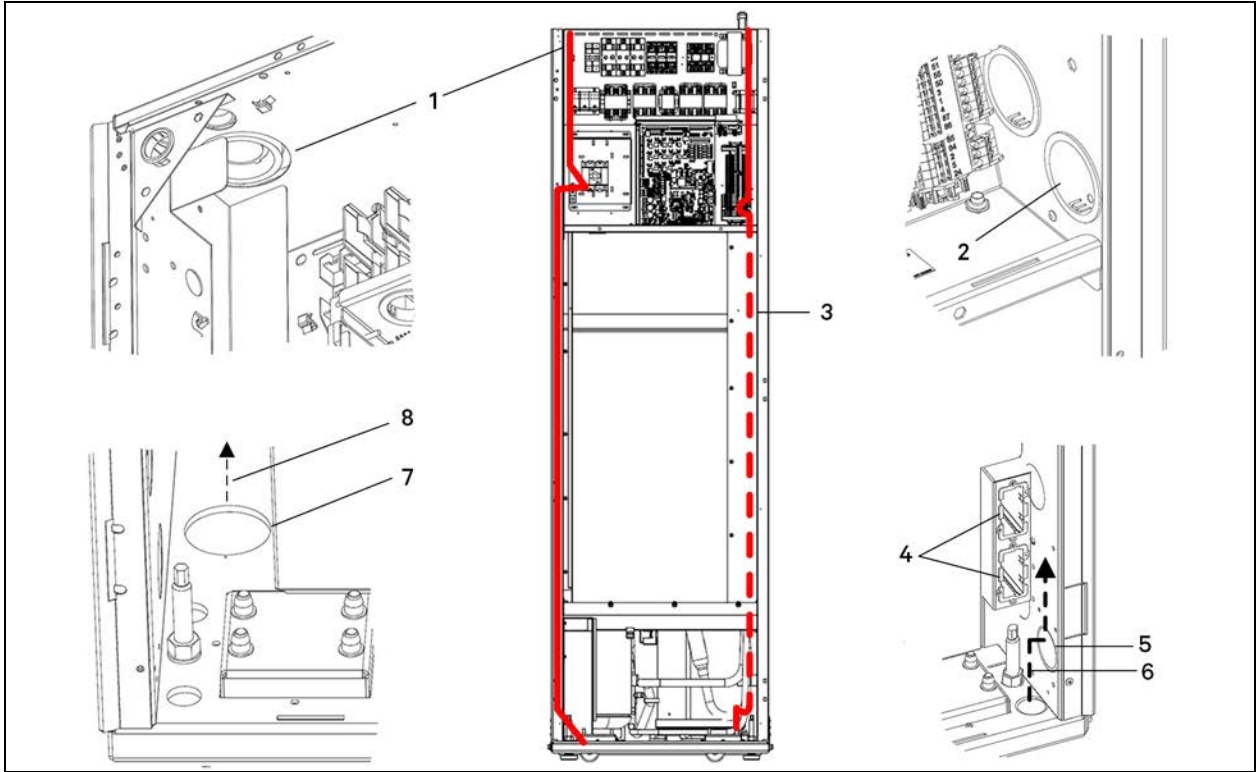

Item	Description
1	High voltage top entry point
2	Low voltage channel opening in side panel
3	Low voltage cables route from top entry, through the channel opening in the side panel, and connect bottom of the unit to the electrical panel.
4	IntelliSlot bays
5	Low voltage bottom port entry
6	Low voltage cable path to electrical panel
7	High voltage bottom-entry knockout
8	High voltage cable path

7.3.3 Protective Features of Electrical Heaters—600-mm (24-in.) Units

Figure 7.4 below shows the temperature-sensor protection on the electrical heaters.

Figure 7.4 Electrical Heating with Temperature Sensor Protection



Item	Description
1	Temperature sensor protection

7.3.4 Accessing the Electrical Panel on 300 mm (12 in) Units

The electrical panel is located on the rear of the unit behind the filters. Pulling out the electric panel—300 mm (12 in.) on the facing page shows the details to pull out the panel.

To access the electrical panel:

1. Remove the filters.
2. Turn the main disconnect "Off" and release the quarter-turn latch.

NOTE: The main disconnect switch must be Off before the electrical panel will slide out, and it will not switch to On until the panel is fully inside the unit.

3. Slide the electrical panel out of the unit until the slides on the panel locking. See Releasing the Electricpanel Lock on the facing page to slide the electrical panel into the unit.

Figure 7.5 Pulling Out the Electrical Panel—300 mm (12 in.)

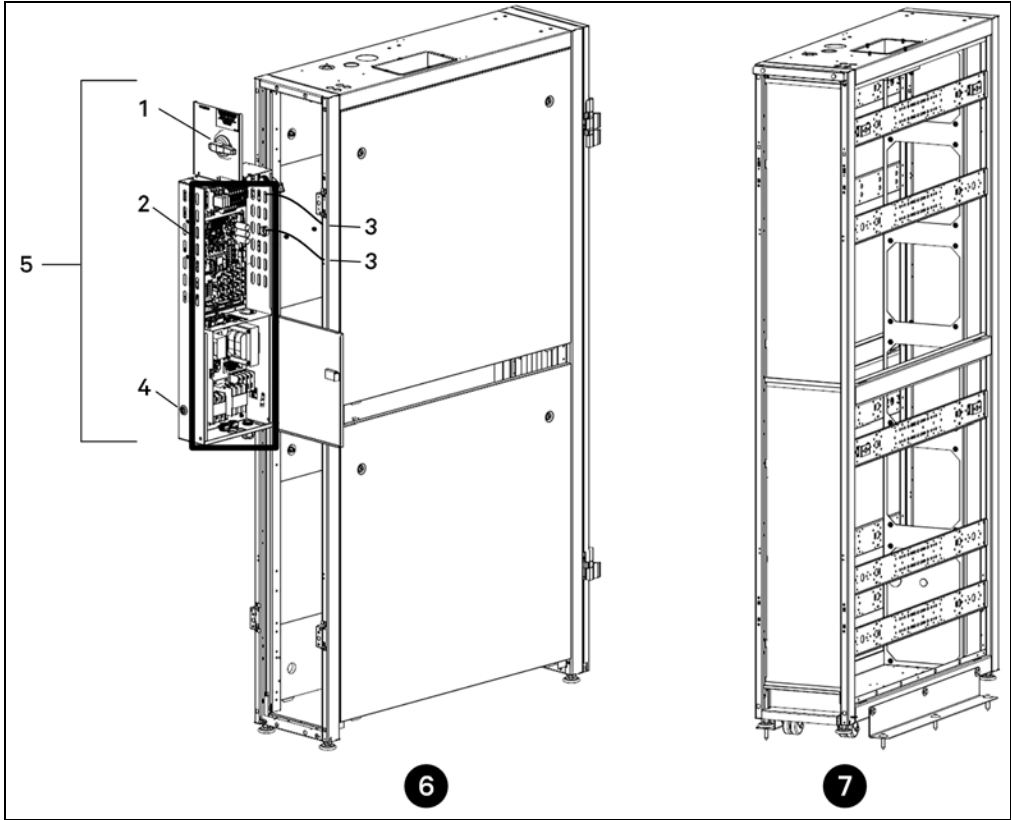

Item	Description
1	Main disconnect switch
2	Low voltage electrical panel
3	Low voltage electrical wiring (the lower conduit carries factory wiring)
4	Quarter turn latch
5	Electrical panel, slides out
6	Rear of unit, filters removed and electrical panel accessible
7	Rear of unit, filters installed

7.3.5 Releasing the Electric Panel Lock

When the electrical panel is pulled out, the slides on the panel lock.

To release the lock and push the electric panel in:

1. Press the tab in the center of the bottom slide, shown in Electric panel lock on the next page.
2. Then press the tab on the top slide while pushing the panel into the unit.
3. Lock the panel in place with the quarter-turn latch.

NOTE: The main disconnect switch will not switch to On until the panel is fully inside the unit.

Figure 7.6 Electric Panel Lock

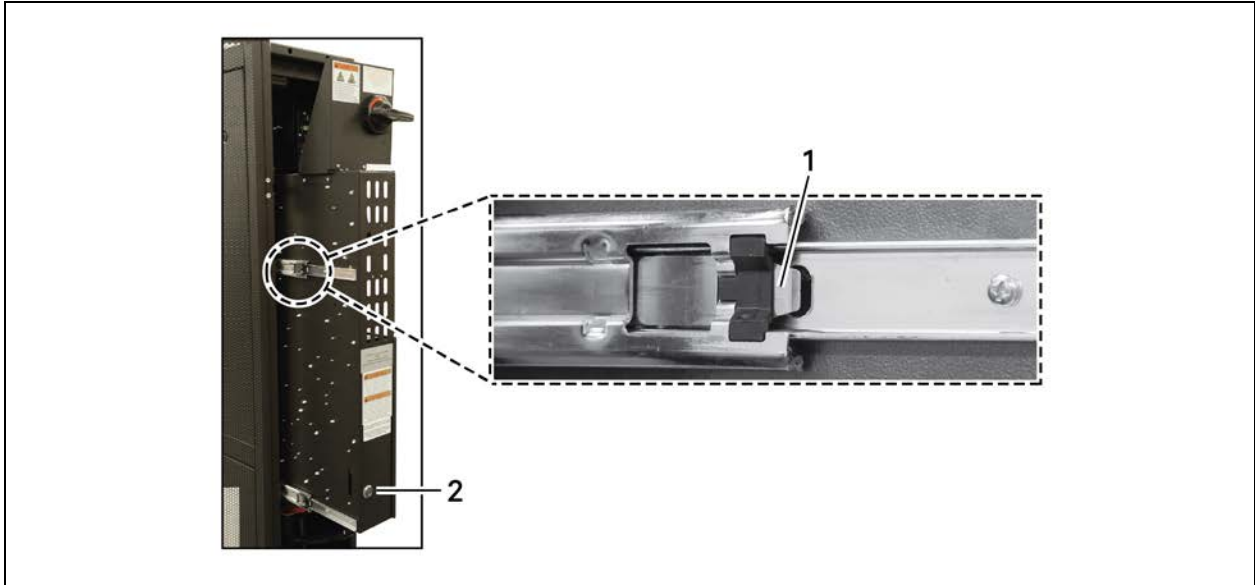

Item	Description
1	Slide lock latch, press to release
2	Quarter turn latch

7.4 Protective Features of the Electronically Commutated (EC) Fans— All Models

The EC fans are protected against:

- Over temperature of electronics
- Over temperature of motor
- Locked rotor protection
- Short circuit at the motor output

When any of these failures occurs, the motor stops, electronically, with no potential for separation, and the status relay is released.

The unit does not restart automatically. To reset the alarm, the power supply must be switched Off for 20 minutes once motor is at standstill.

- Input power under voltage detection:

If the utility power falls below the trip value of the below table (typical value) for 5 seconds or longer, the motor is switched Off, electronically, with no potential for separation, and the status relay is released.

When the utility voltage returns to a correct value, the motor restarts automatically.

Unit Input Power	Fan Under Voltage Trip
208 VAC	< 243 VAC

- Phase failure recognition:

If one phase fails for 5 seconds or longer, the motor is switched Off, electronically, with no potential for separation, and the status relay is released.

When all three phases return to correct values, the motor restarts automatically in 10 to 40 seconds.

The power supply for an external speed setting potentiometer is protected against short circuiting.

The motor is overload protected via motor current limitation.

This page intentionally left blank

8 Humidifier 600 mm (24 in.) Units Only

8.1 Principal of Operation

When the Liebert® iCOM calls, the cylinder fills to 100% of the Full Load Amperage (FLA) or to the top of the cylinder, whichever comes first. See **Figure 8.1** below . If it reaches 100% FLA, the water heats and boils away to a level giving 80% FLA. An electronic timer uses the rate of amp fall to determine the water level. The objective is to concentrate current carrying minerals in the cylinder so that a smaller volume of water is required to produce the rated steam output. This extends the life of the disposable cylinder by minimizing electrode coverage and reducing energy use because the high concentration allows a minimal drain rate. When 80% FLA is reached, the fill valve will open, refilling the cylinder to 100% FLA. On occasion, the drain valve will also come on if the water level is too low, indicating too high a concentration and the need to dilute the water in the cylinder. If the water reaches the top of the cylinder before 100% FLA, the fill valve shuts Off via the sensor, and the fill-boil-fill-boil cycle continues, cycling Off the red high water sensor light until the concentration becomes high enough to reach 100% FLA. The above described control process will then take over.

Figure 8.1 General Diagram—Humidifier Operation

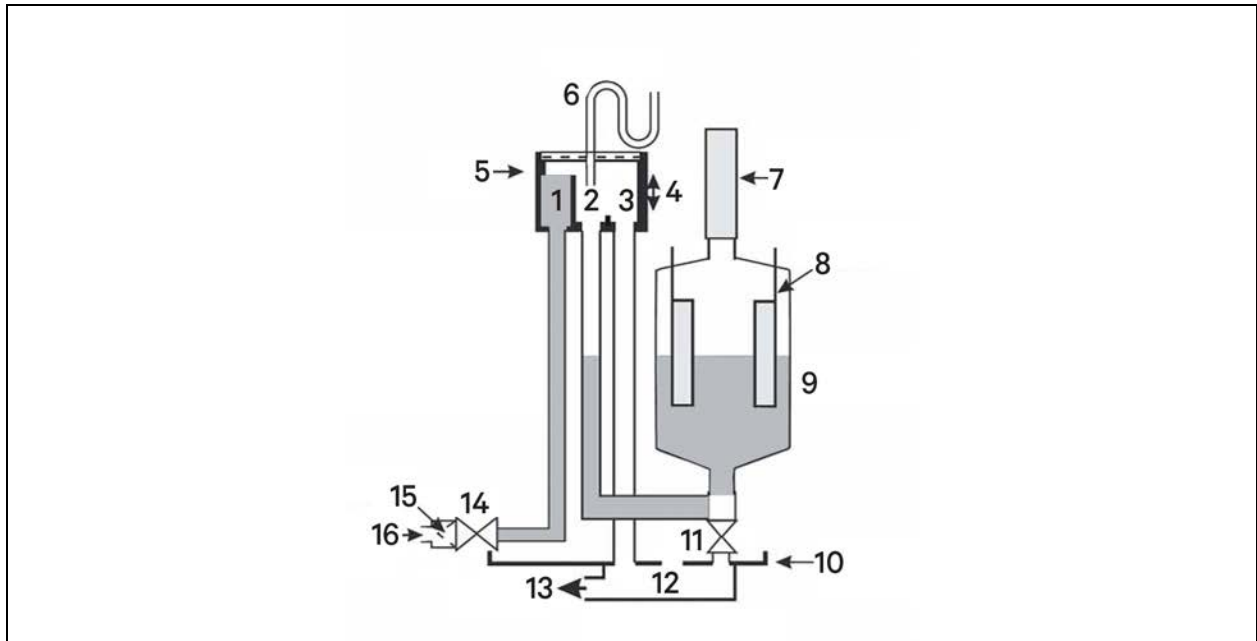

Item	Description	Item	Description
1	Inlet chamber	9	Cylinder
2	Fill chamber	10	Drain pan
3	Water over-flow chamber (safety drain in case of fill valve/control board failure)	11	Drain valve
4	1 in. air gap	12	Drain canal (open to atmosphere)
5	Fill cup	13	Drain connection

Item	Description	Item	Description
6	Condensate return (optional)	14	Fill valve
7	Steam hose	15	Strainer
8	Electrodes	16	Tap water supply

NOTE: The Liebert® iCOM control monitors the condition of the air discharging from the unit to protect neighboring electronic equipment. The Liebert® iCOM will prevent the humidifier from activating if the discharge air is near its saturation point. This protects against discharging fog from the unit or condensation forming on the unit’s supply air baffles. This protection mode is activated when the supply air leaving the unit is below 64°F (17.8°C) or above 55% relative humidity. The Liebert® iCOM screen will display “Humidifier Suspended.” The screen will display “Humidifier Resumed” when the protection mode resets at 67°F (19.4°C).

8.2 Connecting Water Supply to the Humidifier

For top piping connections, piping is connected directly to the humidifier. For bottom piping connections, the compression fitting is removed at the humidifier and then replaced in the field.

An isolating valve should ALWAYS be placed in the feed water line to allow service of the fill valve.

Each unit is fitted with a fill solenoid valve located on the base drain pan.

Flow openings are designed for water pressure from 30 to 80 psi and are protected by the built-in strainer.

For inlet water pressure outside this range, the factory should be contacted.

Figure 8.2 Water Connection to Humidifier

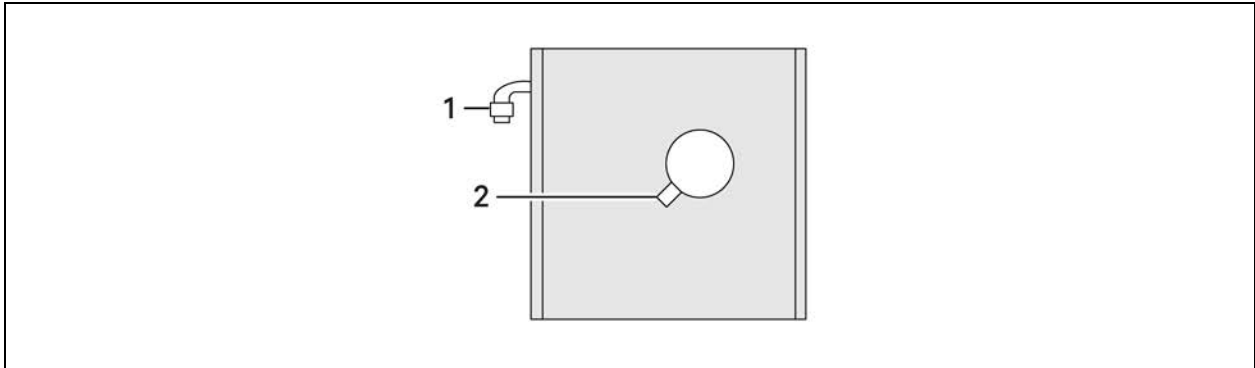

Item	Description
1	3/8 in. Cold water olive connection
2	7/8 in. Drain connection Use factory supplied 7/8 in. OD hose.

8.3 Humidifier Startup and Operation

- Ambient temperature location for humidifier: 41 - 104°F (5 - 40°C).
- Relative humidity location for humidifiers: 5 - 80% RH.

Check to see that the unit is securely mounted on a level surface with the proper drain and water supply. Check for correct voltage with appropriately sized service. Check that the steam distributor, steam supply hose and condensate line are correctly installed and routed back to the unit.

Check all electrical connections for wires that may have become loose in shipping. Components damaged because of loose connections are NOT under warranty.

Check electrode plugs to ensure they are pressed firmly onto the electrode pins. Important: Loose connections will cause overheating of the cylinder plugs, possibly melting the plugs and/or cylinder.

1. Open the isolating valve in the feed water line to the unit.
2. Make sure the Liebert® iCOM is set high enough to call for humidification.
3. Turn on the main disconnect in the primary service feeding the unit and check that unit has power at the primary terminal block.
4. Push the auto On/Off/Drain Switch to "On."

Water will start to enter the cylinder through its bottom port and rise in the cylinder to a point determined by the solid state control circuitry. It is not unusual upon initial start up for the water to fill the cylinder and cycle on the red high water sensor light.

The red light simply acts as a safety to shut off the fill valve and prevent overfilling. With the red light on, the water in the cylinder will continue to heat and, after a few minutes, start to boil. After the boiling of the water has lowered the water level below the sensor at the top of the cylinder, the red light will go out and the fill solenoid will again open until the cylinder is again full. This cycling of the red light and fill valve will continue until the unit's full output capacity is reached, after which the water level will automatically lower itself in the cylinder. (The increased concentration allows for lower electrode coverage while maintaining the same output.) When a stabilized condition is reached, the water will be boiling close to the cylinder seam level. The solid state circuitry will maintain the proper concentration in the cylinder by introducing short drains only when necessary. If the cylinder is manually drained, the above process will repeat itself.

8.3.1 Low Water Conductivity

Should normalization of the unit be required immediately after start up, the installer may speed up the process by artificially increasing water conductivity. During a fill cycle, the installer should dissolve half a teaspoon of table salt (no more) in a cup of water and add it to the cylinder by means of the fill cup attached to the plumbing section. Open the plumbing compartment and add salt solution through cylinder outlet. Excessive amounts of salt will result in erratic operation of the unit; however, normalization of the unit will occur automatically through the solid state control sequence.

8.4 Humidifier Canister Replacement



WARNING! Risk of electric shock. Can cause equipment damage, injury or death. Open all local and remote electric power supply disconnect switches and verify with a voltmeter that power is off before working within any electric connection enclosures. Service and maintenance work must be performed only by properly trained and qualified personnel and in accordance with applicable regulations and manufacturers' specifications. Opening or removing the covers to any equipment may expose personnel to lethal voltages within the unit even when it is apparently not operating and the input wiring is disconnected from the electrical source.



WARNING! Risk of humidifier canister meltdown, smoke and fire. Can cause fire suppression system activation, fire and smoke alarm activation, equipment and building damage, injury and death. The steam cylinder is disposable and must be replaced at the end of its service life. A cylinder's service life depends on water supply conditions and humidifier usage. Using a humidifier canister that has reached the end of its service life can be extremely hazardous. If the canister cannot be replaced immediately at the end of life condition, turn Off the power and water supply to the humidifier and remove the canister until a replacement canister can be installed.



CAUTION: Risk of contact with hot surfaces. Can cause injury. The compressor, refrigerant discharge lines, fan motor, and some electrical components are extremely hot during unit operation. Allow sufficient time for them to cool to a touch safe temperature before working within the unit cabinet. Use extreme caution and wear appropriate, OSHA-approved PPE when working on or near hot components.

After an extended period of operation, in accordance with life expectancy information, the cylinder is completely used as indicated by the amber high water sensor light illuminated on the cabinet. Then this condition is reached, a new replacement cylinder must be installed.

NOTE: The amber high water sensor light may come on during initial startup, but this instance does not indicate that the cylinder should be replaced.

The steam cylinder is disposable and must be replaced at the end of the cylinder's life. Cylinder life will vary according to water supply conditions and humidifier use.

Contact your local Vertiv representative to obtain a replacement cylinder. To obtain the correct cylinder, supply the cylinder model from the white 3 digit label on the cylinder, or supply the model, voltage and serial number from the unit specification label.

8.4.1 Removing the Old Canister

To replace a used up humidifier cylinder:

1. Turn off the water supply to unit.
2. The old cylinder must be drained completely before removing. This is done by pushing the auto On/Off/drain switch to the Drain position.
3. When completely drained, push the auto On/Off/Drain switch to the Off position.
4. Open the main electrical disconnect during the entire cylinder change operation.
5. The power wires to the cylinder are attached by cylinder plugs to the electrode pins on top of the cylinder. Pull up to remove the plugs from the pins.
6. Use slotted screwdriver to loosen the steam hose clamp(s)

7. Disconnect the steam hose by pulling it straight up.
8. Loosen the reversible cylinder zip tie.
The cylinder is now ready to be lifted out of the unit.

8.4.2 Mandatory Cleaning of the Drain Valve

Always clean the drain valve before installing a new cylinder. **Figure 8.3** below, shows an exploded view of the drain valve for reference to clean it.

1. Remove old cylinder as described in [Removing the Old Canister](#) on the previous page.
2. Note that the ring terminal for the drain valve green ground wire is sandwiched between the drain valve and the drain pan.
3. Remove the two screws securing the drain valve body to the drain pan.
4. Remove the hose clip and hose connection from the drain valve body.
5. The drain valve assembly is now free for disassembly and cleaning.
6. At a sink, remove the snap fit red cap from the coil assembly and slide the coil off the actuator.
7. Loosen actuator using a wrench and unscrew from the plastic body.
8. Clean the exposed core, spring and plastic drain valve pot
9. Reinstall in the reverse order.

NOTE: Be cautious when putting the spring back into the plunger, the taper end of the spring must be installed toward the solenoid.

10. Hand tighten the actuator back into place, then secure it using a wrench to turn it a quarter of a turn.
11. Clean out the end of the hose, then reconnect it to the drain valve body with the clamp.
12. Fit mounting screws back through the drain valve body, one through ring terminal on the green wire.

Figure 8.3 Drain Valve Assembly

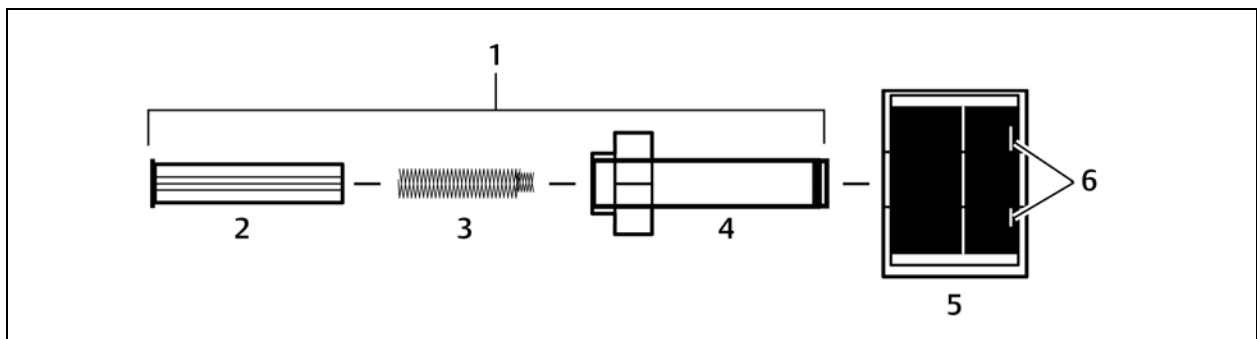

Item	Description
1	Actuator
2	Plunger
3	Spring
4	Sieve
5	Holding coil
6	Male, slip on connection tabs

8.4.3 Installing the New Canister

1. The reverse procedure should be followed to install a new cylinder. The main electrical disconnect is to be left open until the cylinder is completely installed and reconnected.
2. The blue sensor plug on all units is for the high water sensor pin, which always goes on the single pin with collar offset from the others. See **Figure 8.4** below .
3. Ensure that cylinder plugs are snug on the pins. Replace any loose fitting plugs as these may result in hazardous operation.



WARNING! Risk of humidifier canister meltdown, smoke and fire. Can cause fire suppression system activation, fire and smoke alarm activation, building evacuation, dispatching of fire and rescue equipment and personnel and water leaks resulting in expensive equipment or building damage, injury or death. Check steam generating humidifier electrode plugs to ensure that they are pressed firmly onto pins. Loose connections will cause overheating of cylinder and plugs.

Figure 8.4 Sensor Pins, Cylinder Plugs

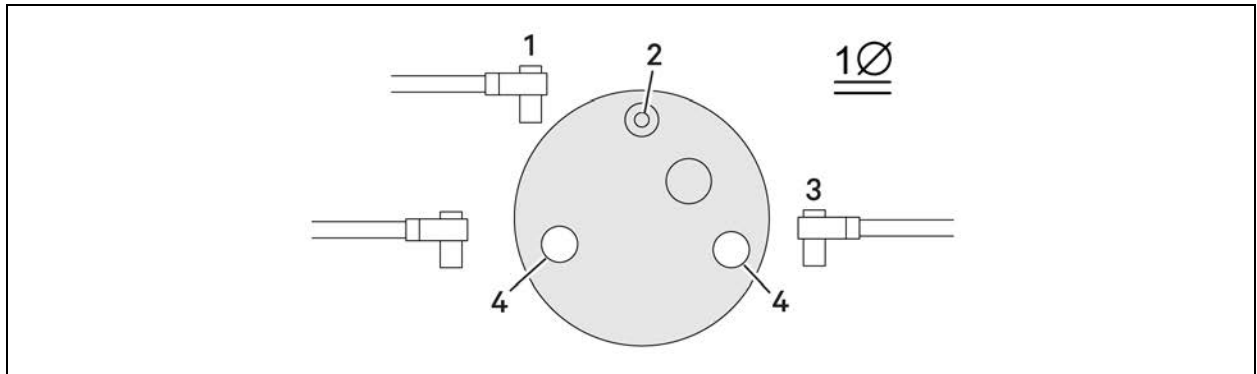

Item	Description
1	White sensor plug
2	Sensor pin
3	Cylinder plug
4	Cylinder pin

8.5 Humidifier Maintenance during Extended Shutdown



WARNING! Risk of electric shock. Can cause equipment damage, injury or death. Open all local and remote electric power supply disconnect switches and verify with a voltmeter that power is off before working within any electric connection enclosures. Service and maintenance work must be performed only by properly trained and qualified personnel and in accordance with applicable regulations and manufacturers' specifications. Opening or removing the covers to any equipment may expose personnel to lethal voltages within the unit even when it is apparently not operating and the input wiring is disconnected from the electrical source.

Always drain the cylinder before disconnecting power to the humidifier for a period of extended shutdown. Otherwise, the electrodes are subject to harmful corrosion, which drastically shortens the cylinder life. Do not leave the switch in the DRAIN position indefinitely because the drain coil could burn out. Leave the switch in the Off position and open the main external fused disconnect to stop power to the humidifier. Close the shutoff valve in the water supply line feeding the humidifier.

8.5.1 Humidifier Troubleshooting

Terms used in humidifier troubleshooting:

- **FLA (Full Load Amps)** are amps listed on the humidifier specification label.
- **Short cycling** occurs when the humidifier's "On time" is less than 10 minutes upon a call for humidity. To correct short cycling, all humidifiers have a capacity adjustment that allows the output of the humidifier to be reduced to as low as 20% of rated output, thus extending the "on time" required to maintain output.
- **Foaming** can occur when the impurities already in water reach an excess concentration as a result of boiling away water and continued boiling agitates the contained water. The humidifier electronics are designed to prevent foaming, although in extreme cases water will foam with little concentration, making it necessary to increase the drain time of the water contained in the cylinder. Foaming is normally caused by short cycling, a restricted drain or back pressure. The foam generated in these instances is conductive and may lead to false full-cylinder indication if the level of the foam approaches the top of the cylinder.
- **Back pressure** is the restriction of steam flow caused by long steam runs, improperly sloped steam lines, elbows changing the direction of steam flow from horizontal to vertical without a drain leg, any plumbing detail allowing the accumulation of condensate, undersized steam line, improper steam distributor, downward air flow onto the distributor causing excess static pressure at the steam outlets, or high static pressure ducts (not probable). To overcome excess static pressure in the duct, use a fill cup extension kit. In downflow applications, a downflow distributor should be used, but in some cases the fill cup extension will also be required.
- **Reset unit (humidifier):** To reset the humidifier, switch the auto On/Off/Drain switch at the front of the humidifier to the Off position for at least five seconds, then switch it back to the On position.
- **Monitored leg** is the primary wire to the cylinder that loops through the current sensing device of the main PCB. This wire ends at the red cylinder plug at the cylinder.

Table 8.1 Steam Generating Humidifier Status Lights: Causes and Corrective Actions

Unit Status light		Symptom	Corrective Actions
Yellow	Green		
On	On	Maximum water level inside cylinder.	<p>This usually happens on initial startup after replacing the cylinder (normal). Water is concentrated with minerals inside the cylinder.</p> <p>Let unit run; yellow light will disappear when the unit is at full output. This may take a day or two.</p>
Off	Off	No power to the board.	<p>Check for main power supply fault.</p> <p>Turn power switch to "Drain" position. If drain valve is activated (sound of solenoid), check connection to the board or board itself.</p> <p>When no sound is present, check fuse (replace with 3.0 A if needed), transformer (voltage should be present between fuse holder and ground screw).</p>
1 flash sequence	Off	Excess current. Operating amperage exceeded 130% of rated amps. Water is drained from the cylinder (drain valve on for 10 minutes).	<p>Check drain valve operation, drain time, possible drain restrictions.</p> <p>Check fill valve for leaks (not holding supply water).</p> <p>Back pressure may also cause very conductive water conditions. Check for short cycling. Water conductivity too high.</p>
2 flashes in sequence	Off	No current detection for 30 minutes with continuous call for humidity.	<p>Check water level in the cylinder - should be more than 1/4 full. If not, check fill rate, 24 VAC on fill valve terminals (unit must be on with call for humidity - green light on steadily). Verify fresh water supply to the humidifier. Leaking drain valve may be at fault (minerals blocking the plunger).</p> <p>If cylinder is more than 1/4 full, check primary power, connections to the cylinder, continuity of wires to cylinder.</p> <p>Are power wires connected to proper terminals on the cylinder? (Color coding.) Possibly wrong cylinder type.</p> <p>Low water conductivity.</p>
4 flashes in sequence	Off	End of cylinder life - change cylinder.	<p>Check water level in the cylinder; should be about 3/4 full.</p> <p>Check for foaming if water level is lower or cylinder life shorter than expected.</p> <p>Change cylinder, clean drain valve.</p>

Table 8.2 Steam Generating Humidifier Troubleshooting Guide

Symptom	Possible Cause	Check or Remedy
Unit in call for humidification, humidifier will not operate	Humidifier not receiving power	Verify ON/OFF/DRAIN switch is in ON position.
		Check fuses or CB's and replace or reset if necessary.
Humidifier contactor pulled in, but no water enters canister	No water available to unit	Check external water shut off valves.
	Clogged fill line strainer	Clean or replaced fill line strainer
Excessive arcing in canister	Drain valve clogged or defective	Verify that drain valve operates freely when activated. Clean valve and replace if defective. Flush canister several times and replace if arcing persists.
	Improper water supply	If water is commercially softened, reconnect humidifier to raw water supply, drain canister and restart. If connected to hot water supply, reconnect to cold water.
	Insufficient drain rate	Verify that drain valve operates freely when activated. Clean valve and replace if defective. Flush canister several times and replace if arcing persists.
	Excessive mineral content in water	Analyze mineral content of water. If mineral content is excessive contact Vertiv Technical Support.

8.5.2 Humidifier Troubleshooting Steps

Auto On/Off/Drain switch in On position—unit will not fill:

When the On/Off control circuit is made and the Auto On/Off/Drain switch is pushed to On, the 24V holding coil of the primary contactor should energize. The resulting magnetic pull closes the high voltage contacts with a distinct and audible “clunk.” If the contactor will not make the connection, then inspect the following while referring to the wiring diagram:

- Check for 24V across terminals 18 and 26 on the PC board.
- The low voltage 3A fuse located in the control box may be blown.
- The contactor holding coil may be open or shorted.
- The switch may be defective.

Recheck that the Auto On/Off/Drain switch is still On. If it is, shut off the main disconnect and check fuses or breaker of the main disconnect. If they are serviceable, turn power back on.

To test for a defective Auto On/Off/Drain switch, connect a wire from the fuse directly to Terminal 6 on the external controls strip. If the contactor activates, the On side of the switch is defective. If the contactor does not activate, the PC board could be defective.

If the 3A control fuse blows when the wire from the fuse touches Terminal 6 on the external controls strip, the contactor holding coil may be shorted. Replace contactor if necessary.

After the necessary components have been replaced and the contactor pulls in, there is line voltage to the cylinder and the control sequence can begin.

Approximately 30 seconds after the contactor pulls in, the fill valve coil should energize. There is also a visible fill relay on the printed circuit board. It is the one located farthest from the C.T. core. The points on this relay must be touching in order for the fill valve coil to be energized. If the points do not touch after the built in time delay, the sensor input may be interfering. To confirm, remove the black and red sensor wires from terminals 6 and 10 on the PC board. Wait 30 seconds and, if the fill relay points do not touch, replace the sensor. If they still do not touch, the basic PC board may be faulty. To confirm, disconnect the red wire from terminal 18 and touch it to terminal 14. If the fill valve coil activates, the basic PC board should be replaced. If it still does not activate, the fill valve coil should be replaced. After the necessary components have been changed, water will start filling the cylinder and begin to submerge the electrodes. Because of the high voltage across the electrodes, the water can now conduct electricity.

Red “Change Cylinder” light on—Water at top of cylinder:

This is a common occurrence on start up. See [Startup](#) on page 89 .

Water remains at high level and won't concentrate:

This is normal on cold start-up and can be accelerated by adding a maximum of 1/2 tsp. of dissolved salt to the cylinder on fill cycle through the plastic fill cup. See .

If the unit has been operating extensively, observe for normal fill-boil-fill-boil cycle; no drainage should occur. If drainage occurs, check for leaking drain valve or back pressure.

Unit drains continually:

May be caused by foaming and/or back pressure or by a leaking drain valve.

If cylinder is almost empty, check for magnetic pull on drain solenoid indicating miswiring. If there is no pull, drain actuator is blocked open; remove, disassemble and clean.

If drain is occurring through activated drain valve, valve is miswired or electronics are faulty; consult factory.

If drain is occurring through the overflow on the fill cup, this is due to abnormal restriction on the steam line and back pressure forcing water out of the cylinder so water cannot concentrate and level remains high. Review installation of steam line to ensure there are no blockages or excessive static pressure in the air system.

9 Startup



WARNING! Risk of hair, clothing and jewelry entanglement with high speed rotating fan blades. Can cause equipment damage, serious injury or death. Keep hair, jewelry and loose clothing secured and away from rotating fan blades during unit operation.



WARNING! Risk of contact with high speed rotating fan blades. Can cause serious injury or death. Open all local and remote electric power-supply disconnect switches, verify with a voltmeter that power is off, and verify that all fan blades have stopped rotating before working in the unit cabinet or on the fan assembly. Fan motor controls can maintain an electric charge for 10 minutes after power is disconnected. If control voltage is applied, the fan motor can restart without warning after a power failure.

To start the Liebert® CRV:

1. Open all valves in the refrigeration circuit according to the instruction label attached to the valve.
2. **Water/Glycol Cooled Models Only:** Open all valves in the water circuit according to the instruction label attached to the valve.
3. Ensure that the refrigerant charge is correct (see).
4. Using a leak detector, verify that there are no refrigerant leaks. If any leaks are detected, repair them and recharge, depending on your system, as described in or .
5. At least 4 hours before start up, close the main switch and the compressor switch on the electric panel.

NOTE: The default setting for the Liebert® iCOM control is for stand-alone operation. The stand-alone mode lets you turn on the unit by rotating the main switch on the electrical panel. The yellow LED on the iCOM display panel lights after the unit is turned on because electrical power is present.

If the LED does not light:

- Check the electrical panel power supply.
 - Check the protection devices (for example, thermal switches).
 - Check the fuses.
6. Verify that the crankcase heater is working.
 7. Check to ensure that there are no water leaks.
 8. If an external condenser or drycooler is installed, start it by supplying power to it.
 9. Close all MCBs on the electrical panel.
 10. Check the supply voltage on all phases.
 11. Check the supply voltage on all phases for the external condenser or drycooler, if fitted.
 12. Start the unit by pressing the On/Off switch.
 13. Check the amp draw of all components (see [Electrical Connections](#) on page 69).
 14. Check the amp draw of the external condenser/drycooler, if fitted.
 15. If the compressor makes a loud, unusual noise, invert the electrical connections of the phases supplying the unit, which accepts only one direction of rotation.
 16. Ensure that the fans rotate in the correct direction (see arrow on fan).

17. Ensure that all control system settings are correct and that there are no alarms (see Liebert® iCOM Control).
18. **Water/Glycol Cooled Models Only:** Verify the water flow is adequate.
19. **Water/Glycol Cooled Models Only:** For closed circuit units, ensure that the water pump starts when the compressor starts.

9.1 Checks to Perform after Startup

Once the system is operating under load, check the various components, as follows:

1. Verify that the fans are operating properly.
2. Ensure that the temperature and relative humidity are being controlled, and that the humidifier (optional) and heating steps (optional) operate when required.
3. Ensure that the compressor operates when required.
4. Ensure that the fan operation controller on the external condenser/drycooler (if fitted) is calibrated correctly, and that it controls the fan operation.
5. Record all of the following on the warranty inspection form:
 - a. All component voltages and current draws
 - b. All air / water temperatures indoor and outdoor
 - c. All refrigerant and water / glycol pressures,
 - d. All levels of refrigerant and oil in sight glasses
 - e. Record refrigerant pressure switch settings and operating pressures
 - f. Record superheat and subcooling.
6. Operate unit at full heat load, normal room conditions, and normal water/glycol fluid temperatures for a minimum of 30 minutes, and read/compare the superheat and subcooling values against . Adjusting the refrigerant charge as described in will maximize unit capacity and efficiency at full-load conditions.

9.2 Automatic Restart

The unit may be set to automatically restart on the return of power after a supply power interruption using the Liebert® iCOM controller.

To avoid an automatic cold restart of the compressor if a power interruption of several hours is expected, stop the unit before the blackout. After power returns, allow the compressor to preheat before restarting the unit.

Figure 9.1 Refrigerant Line Components—All Models, 600 mm (24 in.)

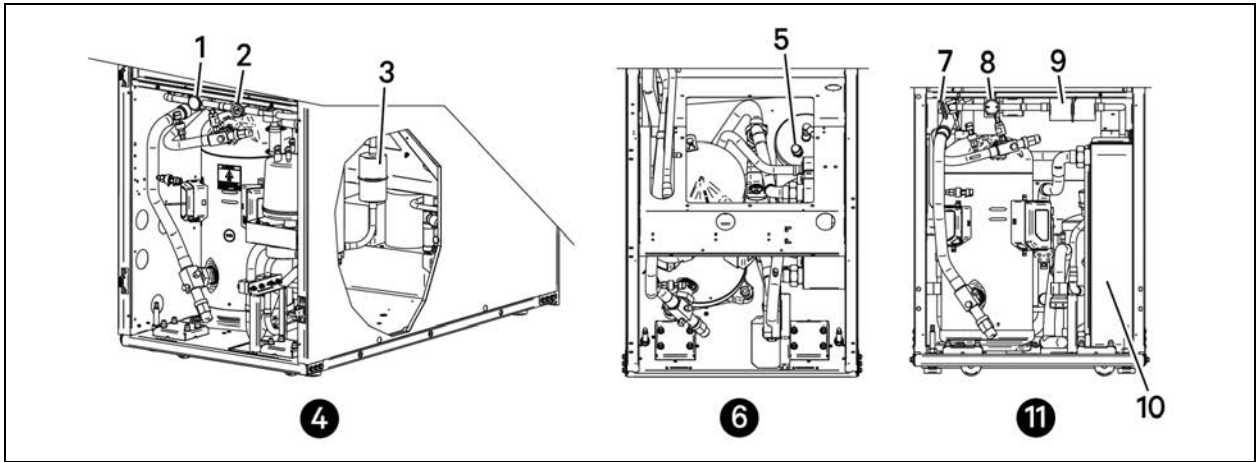

Item	Description
1	Solenoid valve
2	Sight glass
3	Filter dryer
4	Air-cooled unit, rear view
5	Liquid-receiver relief valve
6	Water-cooled unit, top view
7	Thermostatic expansion valve
8	Solenoid valve
9	Filter dryer
10	Brazed-plate heat exchanger (Behind humidifier, humidifier not shown)
11	Water cooled unit, rear view

Figure 9.2 Refrigerant Line Components—Air Cooled, 300 mm (12 in.)

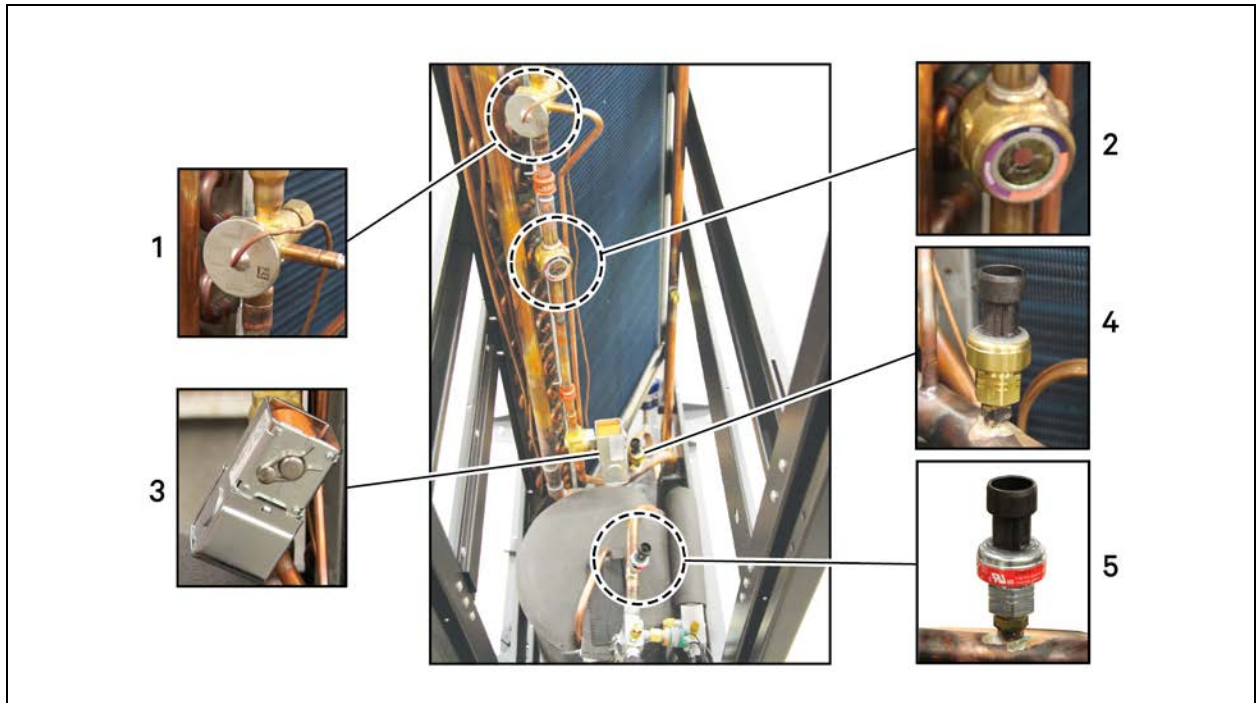

Item	Description
1	Thermostatic expansion valve
2	Sight glass
3	Solenoid valve
4	Pressure transducer
5	Pressure transducer

9.3 Chilled Water Valve— All Chilled Water Models

The chilled water units come with either a two-way or three-way valve, see **Figure 9.3** on the facing page .

The valve controls the chilled water flow and operates as follows:

- When the valve is fully open (i.e., maximum chilled water flow/cooling), the actuator handle is set to the full CW position
- When the valve is closed (i.e., no chilled water flow/cooling), the actuator handle is set to the full CW position

The valve running time is set to the value specified in the control manual.

NOTE: In the event of control system failure, the valve can be manually controlled with the ball valve handle. It can be used to drive the actuator into any position between 0 and 1.

Figure 9.3 Position of the Chilled Water Valve Actuator (for 2- or 3-Way Valve)—600 mm (24 in.) and 300 mm (12 in.) Units

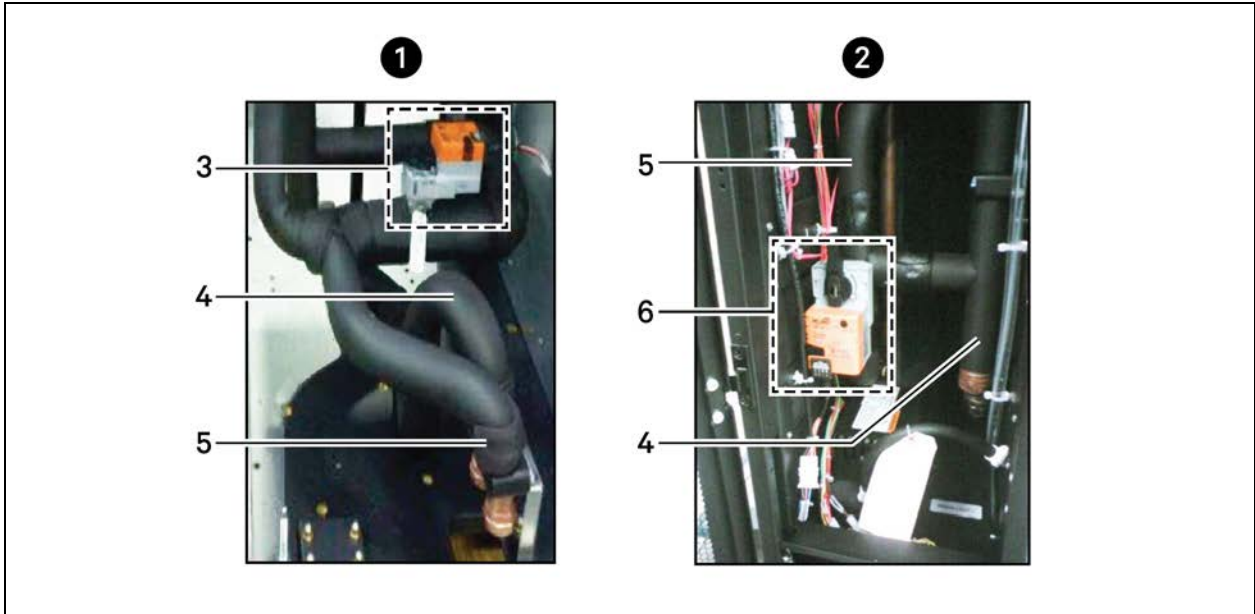

Item	Description
1	600 mm (24 in.) unit
2	300 mm (12 in.) unit
3	Chilled water valve actuator, 2 way valve
4	Water return piping
5	Water supply piping
6	Chilled water valve actuator, 3 way valve

9.4 Adjust Baffles to Direct Air Properly

! **WARNING!** Risk of electric shock. Can cause equipment damage, injury or death. Open all local and remote electric power supply disconnect switches and verify with a voltmeter that power is off before working within any electric connection enclosures. Service and maintenance work must be performed only by properly trained and qualified personnel and in accordance with applicable regulations and manufacturers' specifications. Opening or removing the covers to any equipment may expose personnel to lethal voltages within the unit even when it is apparently not operating and the input wiring is disconnected from the electrical source.

! **WARNING!** Risk of contact with high speed rotating fan blades. Can cause serious injury or death. Open all local and remote electric power-supply disconnect switches, verify with a voltmeter that power is off, and verify that all fan blades have stopped rotating before working in the unit cabinet or on the fan assembly. Fan motor controls can maintain an electric charge for 10 minutes after power is disconnected. If control voltage is applied, the fan motor can restart without warning after a power failure.

The Liebert® CRV is equipped with an adjustable, modular, supply air baffle system. Adjust the baffles prior to start up to direct air toward the racks that the cooling unit is intended to condition. Ideally, these should be the same racks from which the cooling unit is pulling hot air. The baffles can be readjusted at any time as cooling needs change.

The unit ships with the baffles in an alternating pattern to direct cold air left and right. This configuration should be used when the cooling unit is located between racks. If cooling unit is installed at the end of a row, adjust all the baffles to blow air down the cold-aisle, toward the racks. The baffle segments at the top of the panel will direct more air than the segments at the bottom. The supply air will travel the furthest when all baffle segments are pointed in the same direction, left or right.

9.4.1 Adjusting Baffles—600 mm (24 in.)

To adjust the baffles on 600 mm (24 in.) models:

1. Open the door containing the Liebert® iCOM display.
2. Remove the two bolts holding a baffle panel segment in place.
3. Slide out the baffle segment.
4. There is one screw on each side of the baffle, as shown in **Figure 9.4** below. Remove the screws and rotate the baffle segment around its horizontal axis to change the airflow direction.
5. Reinsert the baffle segment and reinstall the screws.

Figure 9.4 Baffle Adjustment for Correct Airflow Direction—600 mm (24 in.)

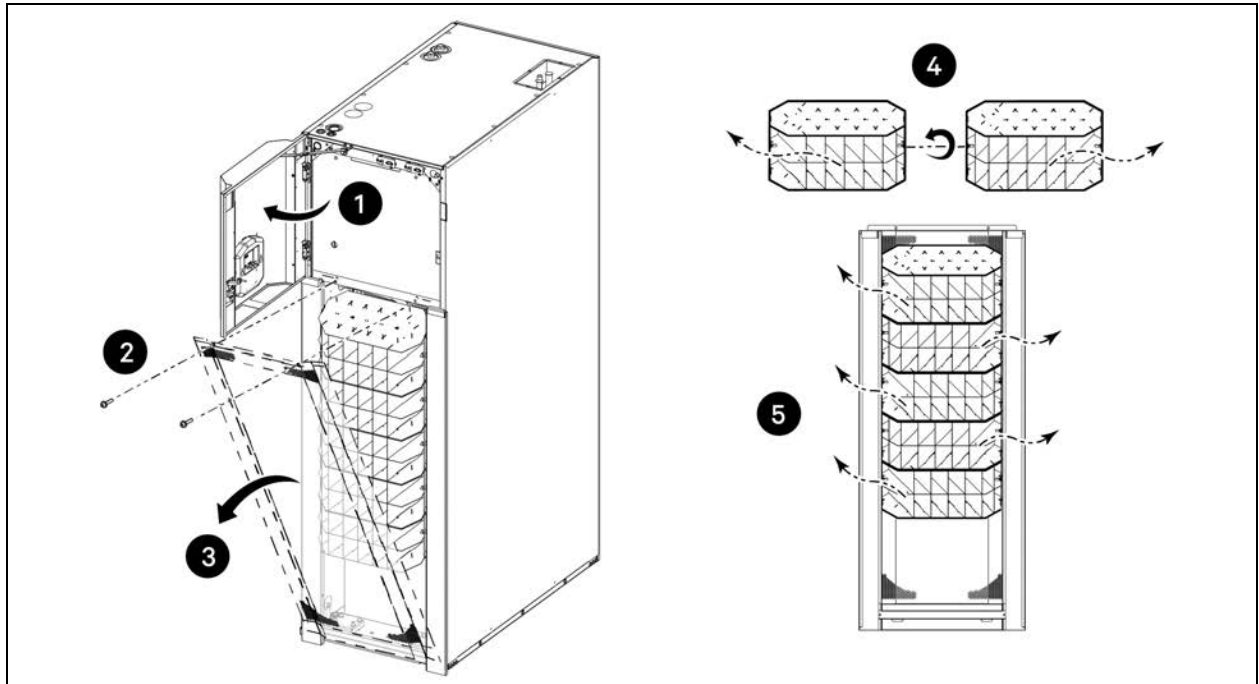

Item	Description
1	Display door (open)
2	Bolts to remove
3	Tilt and lift out baffle panel.
4	Changing baffle panel direction
5	Baffles installed so that discharge air flows upward

9.4.2 Adjusting Blocker Plate—600 mm (12 in.)

A blocker plate inside the display door should also be adjusted to direct air toward the racks that the cooling unit is intended to condition. The blocker plate can be installed on the left or right side of the display door, or it can be removed to discharge air left and right.

To adjust the blocker plate:

1. Remove the three screws that attach the blocker plate to the display door.
2. Reattach the blocker plate to the other side of the display door or to remove it.

Figure 9.5 Air Blocker Plate Adjustment on Inside of Top/Display Door

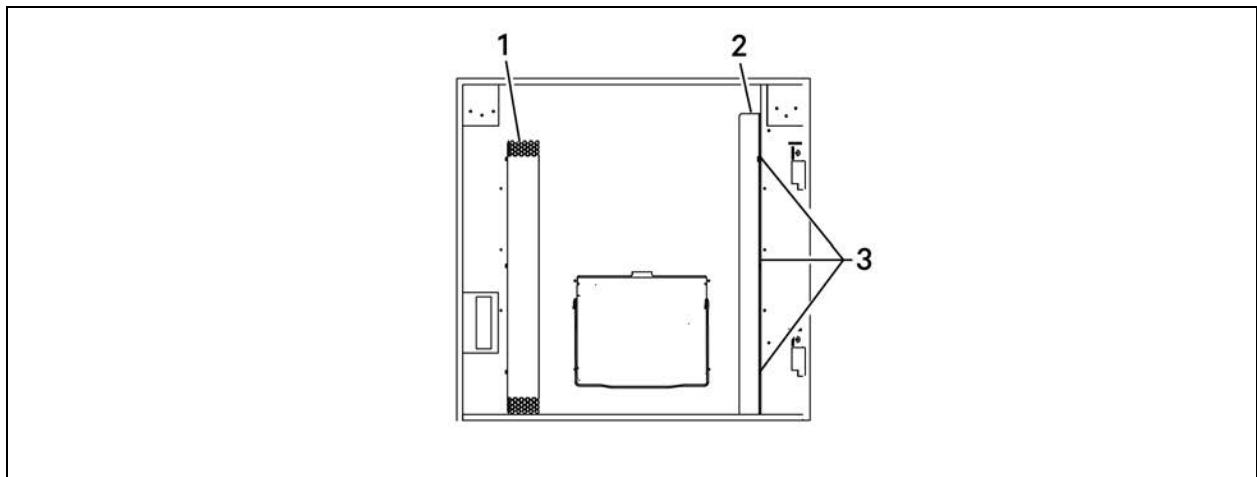

Item	Description
1	Perforated, supply air opening (some perforations removed for clarity)
2	Air blocker over perforations.
3	Attachment screws

9.4.3 Adjusting Baffles—300 mm (12 in.)

To adjust the baffles on 300 mm (12 in.) models:

NOTE: The air baffles on 300 mm (12 in.) units may be changed to direct air either right or left.

1. Shut down the Liebert® CRV.
2. Open the door containing the Liebert® iCOM display.
3. Remove the screws that secure the baffle panel in place.
Each panel is secured with four screws, two on each side.
4. Slide out the baffle panel.
5. Rotate the baffle panel around its horizontal axis to change the airflow direction.
6. Reinsert the baffle panel.
7. Repeat for all baffles to be changed.
8. Reinstall the screws in the metal brace.

Figure 9.6 Baffle Adjustment for Correct Airflow Direction—300 mm (24 in.)

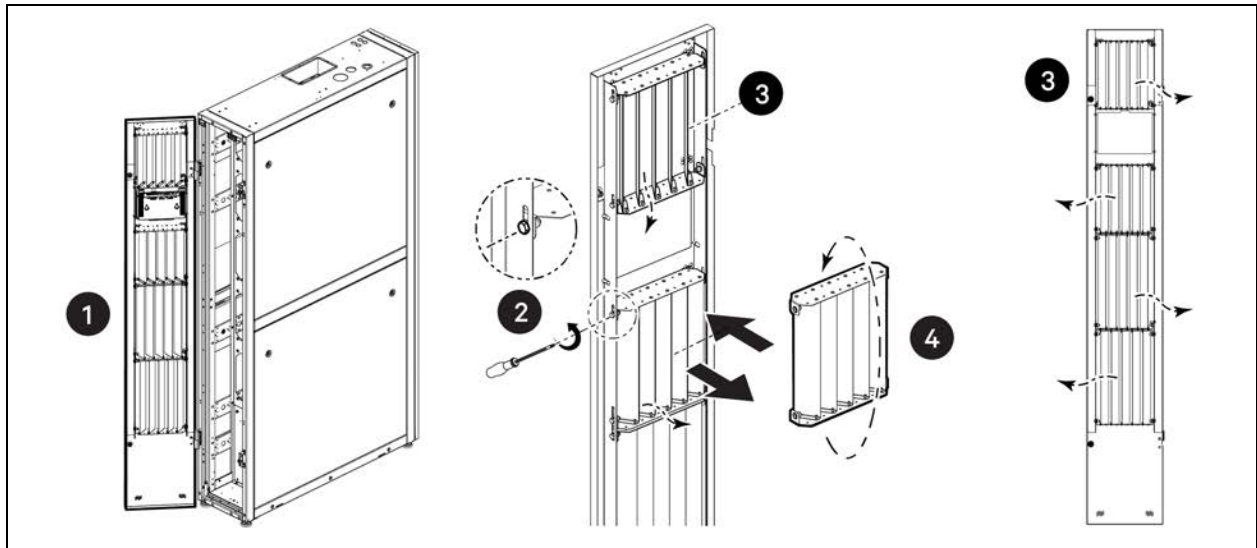

Item	Description
1	Open door
2	Screws securing baffle panel
3	Baffle panel (The arrows represent air flow direction). (When shipped, the baffles alternate as shown).
4	Rotating baffle panels

10 Troubleshooting

Table 10.1 on page 99 lists possible and their cause and corrective steps.

Table 10.1 Unit Diagnostics

Problem	Possible Cause	Corrective Action	
Rack temperature is too high	Dirty filters	Replace filters	
	Filter clog sensor failure	Call Vertiv technical support.	
	Incorrect positioning of remote temperature sensor(s)	Verify that remote temperature sensors are correctly positioned	
	Remote temperature sensor(s) issue		Verify CANbus cable connections and CANbus termination are correct.
			Adjust remote sensor mode (max/average) and number of sensors calculated in average.
			Contact your local Vertiv representative
	Chilled water units: inlet water temperature is too high	Check cooling water temperature	
	Refrigerating circuit charge issue	Contact your local Vertiv representative	
	Cold air short-cycling issues		Verify unit positioning/room configuration
			Verify unit air baffles set-up
			Verify cold aisle containment seals (if applicable)
	Insufficient room-cooling capacity	Reduce rack heat load or add cooling units	
	Chilled water-regulating valve issue	Contact your local Vertiv representative	
Unit safety device tripped	Contact your local Vertiv representative		
Compressor will not load		Verify air temperature setpoint and temperature control sensor reading	
		Verify suction pressure in the service menus, diagnostic service icon with the compressor loaded to 100%. If the suction drops below 109 psi (7.5 bar), the compressor capacity will decrease to help build suction. Verify suction transducer reading is correct compared with a manifold gauge.	
Evaporator Fans will not modulate from 100%	Low pressure condition detected	Verify suction pressure in the service menus, diagnostic service icon with the compressor loaded to 100%. If the suction drops below 109 psi (7.5 bar), the fan speed will increase to help build suction. Verify suction transducer reading is correct compared with a manifold gauge.	
		Contact your local Vertiv representative	
	Fan control not properly set	Refer to the fan-settings descriptions in the "Liebert® iCOM™ User Manual" included with your system documentation.	
		Contact your local Vertiv representative	

Table 10.1 Unit Diagnostics (continued)

Problem	Possible Cause	Corrective Action
Capacity Reduced due to HP Alarm (Comp Reduced by HP)	Condensing pressure (head pressure) has exceeded 493 psig (34 bar)	Air-cooled units: Verify that remote condenser fan(s) are running.
		Check accuracy of transducer by attaching a manifold gauge to discharge side of compressor. Compare gauge reading to what is shown in Service Menus, Diagnostic service mode.
		Water/glycol units: Check cooling water supply
		Water/glycol units: Check cooling water temp
		Contact Vertiv.
Digital Scroll Sensor Failure	Sensor disconnected	Verify sensor reading in User Menu, Sensor Data.
		Check plug connections
		Contact your local Vertiv representative
Low Supply Temperature Alarm/ Room Over-cooling	Low return temperature	Place a unit into standby (if applicable)
	Poor airflow	Install blanking panels in open areas of racks. Consult your local Vertiv representative.
		Direct discharge baffles to heat source
Supply chilled water temperature too low.	Check cooling water temperature	
Low Room Humidity	Humidifier Suspended message.	See Humidification in the "Liebert® iCOM™ User Manual" included with your system documentation.
	Humidifier problem alarm.	Check fault LED on humidifier PCB enclosure.
		See Humidifier Troubleshooting on page 85
Room Humidity Problem	Room humidity has exceeded the humidity control band for 36 hours straight. Verify setpoints and confirm room is properly sealed.	
High Room Humidity	Dehum Suspended message	The operated in dehumidification for excessive time. Dehumidification is suspended to prevent condensation for forming on accent panels and other areas.
	Room Humidity Problem	Room humidity has been below the humidity control band for 36 hours straight. Verify setpoints and confirm room is properly sealed.
Unit fan fails to start	Fan is faulty	Contact your local Vertiv representative
	Top or Bottom Fan Failure Alarm	Confirm rear door switches are made
		Confirm fan contactor is pulled in
		Confirm line voltage is present at the fan
		Contact your local Vertiv representative
Water drops carried by airflow	Room humidity is over acceptable limit	Check room condition
	Condensate pan drain is clogged	Contact your local Vertiv representative
	Problem with humidifier control	Contact your local Vertiv representative

Table 10.1 Unit Diagnostics (continued)

Problem	Possible Cause	Corrective Action
Water on the floor around the unit	Unit is not properly leveled	Adjust the leveling feet
	Unit condensate drain pipe is clogged	Remove pipe obstruction
	Chilled water and water/glycol units: leak in the water circuit	Locate and repair the leak
	Piping insulation broken/damaged	Restore insulation integrity
	Leak in the draining circuit	Contact your local Vertiv representative
	Condensate pump is faulty	Contact your local Vertiv representative
	Leak in the humidifier filling hose	Contact your local Vertiv representative
Unsteady air delivery temperature	Incorrect positioning of remote temperature sensor(s)	Verify correct positioning of temperature sensors
	Unbalanced heat load distribution	Redistribute rack heat load
	Remote temperature sensor(s) issue	Contact your local Vertiv representative
	Faulty temperature sensor(s)	Contact your local Vertiv representative
	Unit controller issue	Contact your local Vertiv representative
Local display is not operational but unit operates	Local display cable disconnected	Connect cable
	Local display cable damaged	Replace cable
	Local display configuration lost	Contact your local Vertiv representative
Local display is not operational and unit does not operate	Unit electrical supply is Off	Restore electrical supply
	Unit main switch is Off	Switch On the unit
	Control board supply issue	Contact your local Vertiv representative
	Control board issue	Contact your local Vertiv representative

Table 10.2 Liebert CRV Medium Control Board DIP Switch Settings

DIP Switch Number	Compressorized CRV Models CR019, CR020 and CR035	Chilled Water Model CR040 and CR050
1	On	Off
2	Off	Off
3	On	Off
4	Off	Off
5	Off	Off
6	Off	Off
7	Off	On
8	On	On

11 Maintenance

11.1 Safety Instructions

All maintenance operations must strictly observe national, state and local accident prevention regulations, especially the regulations concerning electrical systems, refrigerators and manufacturing resources.

Air conditioning equipment maintenance may be performed only by authorized properly trained and qualified personnel.

To keep all warranties valid, the maintenance must adhere to the manufacturer's regulations.



WARNING! Arc flash and electric shock hazard. Open all local and remote electric power-supply disconnect switches, verify with a voltmeter that power is Off and wear appropriate, OSHA-approved personal protective equipment (PPE) per NFPA 70E before working within the electric control enclosure. Failure to comply can cause serious injury or death. Customer must provide earth ground to unit, per NEC, CEC and local codes, as applicable. Before proceeding with installation, read all instructions, verify that all the parts are included and check the nameplate to be sure the voltage matches available utility power. The Liebert® controller does not isolate power from the unit, even in the "Unit Off" mode. Some internal components require and receive power even during the "Unit Off" mode of the controller. The only way to ensure that there is NO voltage inside the unit is to install and open a remote disconnect switch. Refer to unit electrical schematic. Follow all local codes.

Installation, service, and maintenance work must be performed only by properly trained and qualified personnel and in accordance with applicable regulations and manufacturers' specifications. Opening or removing the covers to any equipment may expose personnel to lethal voltages within the unit even when it is apparently not operating and the input wiring is disconnected from the electrical source.



WARNING! Risk of contact with high speed rotating fan blades. Can cause serious injury or death. Open all local and remote electric power-supply disconnect switches, verify with a voltmeter that power is off, and verify that all fan blades have stopped rotating before working in the unit cabinet or on the fan assembly. Fan motor controls can maintain an electric charge for 10 minutes after power is disconnected. If control voltage is applied, the fan motor can restart without warning after a power failure.



WARNING! Risk of contact with extremely hot and/or cold surfaces. Can cause injury. Verify that all components have reached a temperature that is safe for human contact or wear appropriate, OSHA-approved PPE before working within the electric connection enclosures or unit cabinet. Perform maintenance only when the system is de-energized and component temperatures have become safe for human contact.



WARNING! Risk of hair, clothing and jewelry entanglement with high speed rotating fan blades. Can cause equipment damage, serious injury or death. Keep hair, jewelry and loose clothing secured and away from rotating fan blades during unit operation.

NOTICE

Risk of improper maintenance. Can cause equipment damage.

All maintenance must be performed only by authorized properly trained and qualified personnel.

Ignoring safety instructions is dangerous. Soiled parts cause a loss of performance and, for switch or control devices, can lead to the breakdown of the unit performance and operation.

11.2 Facility Fluid and Piping Maintenance for Water and Glycol Systems

Maintaining the system fluid quality is required throughout the life of the system. Fluid and piping system maintenance schedules must be established and performed. A coolant-fluid maintenance program must be established that will evaluate fluid chemistry and apply necessary treatment. The complexity of water/glycol solution condition problems and the variations of required treatment programs make it extremely important to obtain the advice of a competent and experienced water-treatment specialist and follow a regularly scheduled coolant fluid system-maintenance program.

Perform periodic inspections of the facility and the unit coil and/or heat exchanger and coolant-fluid piping system for leaks and visible damage.

11.3 Glycol Solution Maintenance

It is difficult to establish a specific schedule of inhibitor maintenance because the rate of inhibitor depletion depends upon local water conditions. Analysis of water samples at the time of installation and through a maintenance program should help to establish a pattern of depletion. A visual inspection of the solution and filter residue is often helpful in judging whether active corrosion is occurring.

The complexity of water/glycol solution condition problems and the variations of required treatment programs make it extremely important to obtain the advice of a competent and experienced water-treatment specialist and follow a regularly-scheduled coolant fluid system-maintenance program. It is important to note that improper use of water treatment chemicals can cause problems more serious than using none. Proper inhibitor maintenance must be performed in order to prevent corrosion of the glycol system. Consult the glycol manufacturer for testing and maintenance of inhibitors. Do not mix products from different manufacturers.

11.4 Spare Parts

Only original spare parts made by Vertiv must be used. Using third-party material will invalidate the warranty. When seeking technical assistance, always refer to the component list supplied with the equipment, and specify the model number, serial number and, if available, the part number.

NOTE: When replacing a faulty component, follow the relevant manufacturer instructions.

NOTE: When the spare parts must be brazed, be careful not to damage the internal parts (gaskets, seals, O-rings, etc.).

11.5 Maintenance Schedule

Conduct monthly, quarterly, biannual and annual checks according to the following guidelines. Refer to **Table 11.1** on page 104

All tasks and time periods listed here are the manufacturers' regulations and must be documented in an inspection report.

Table 11.1 Maintenance Schedule

Component		Maintenance Period			
		Monthly By User	Every 3 Months	Every 6 Months	Annually
General	Check unit display for clogged-filter warning	X			
	Check for irregular noise from unit fans	X			
	Check for irregular noise from compressor (if applicable)	X			
	Check for irregular noise from remote condenser fan(s) (if applicable)	X			
Filters	Check state of filters		X		
	Replace air filter if necessary		X		
	Check filter switch functionality			X	
Blowers	Verify impellers move freely		X		
	Check bearings			X	
	Check motor mounts for tightness			X	
	Check fan safety switch				X
Electrical/Electronics	Check condition of contacts			X	
	Check electrical connections				X
	Check operation of controller			X	
	Check unit operation sequence			X	
Steam-Generating Humidifier	Check cylinder and pan		X		
	Check condition of steam hoses			X	
	Verify filling solenoid valve is operating properly			X	
Cooling Water Circuit (Water/Glycol and Chilled Water Units)	Check circuit for leakage/general condition		X		
	Check water (glycol) inlet temperature			X	
	Check water regulating valve operation			X	
	Check in/out water (glycol) Dt			X	
	Check mixture glycol level (if applicable)				X

Table 11.1 Maintenance Schedule (continued)

Component		Maintenance Period			
		Monthly By User	Every 3 Months	Every 6 Months	Annually
Refrigerating Circuit	Check compressor noise/vibrations		X		
	Check oil level through compressor sight glass			X	
	Adjust/tighten compressor/functional elements			X	
	Check sight glass for problem detection			X	
	Check starting/running amps			X	
	Check refrigerating circuit main pressures			X	
	Check compressor suction superheat			X	
	Check discharge temperature			X	
	Check subcooling				X
Air Cooled Condenser/Drycooler (if applicable)	Check fan bearings		X		
	Check fan motor mounts for tightness			X	
	Check coil condition			X	
	Check pipeline supports			X	
	Check fan speed controller operation				X
Water/Glycol Pump	See manual for the pump				

11.6 Thermostatic Expansion Valve (TXV) Maintenance

The TXV performs one function: It keeps the evaporator supplied with enough refrigerant to satisfy load conditions. It does not affect compressor operation.

Proper valve operation can be determined by measuring superheat. The correct superheat setting is found in **6.3.8** on page 60. If too little refrigerant is being fed to the evaporator, the superheat will be high. If too much refrigerant is being supplied, the superheat will be low.

11.6.1 Determining Suction Superheat

To determine superheat:

1. Measure the temperature of the suction line at the point the TXV bulb is clamped.
2. Obtain the gauge pressure at the compressor suction valve.
3. Add the estimated pressure drop between the bulb's location and the suction valve.
4. Convert the sum of the two pressures to the equivalent temperature.
5. Subtract this temperature from the actual suction line temperature. The difference is superheat.

11.6.2 Adjusting Superheat Setting with the TXV

To adjust the superheat setting:

1. Remove the valve cap at the bottom of the valve.
2. Turn the adjusting stem counterclockwise to lower the superheat.
3. Turn the adjusting stem clockwise to increase the superheat.

NOTE: Make no more than one turn of the stem at a time. Allow up to 15 minutes of fully loaded compressor operation before checking superheat or making additional stem adjustments.

11.7 Compressor Maintenance



WARNING! Risk of over-pressurization of the refrigeration system. Can cause explosive discharge of high pressure refrigerant, loss of refrigerant, environmental pollution, equipment damage, injury, or death. This unit contains fluids and gases under high pressure. Use extreme caution when charging the refrigerant system. Do not pressurize the system higher than the design pressure marked on the unit's nameplate.

11.7.1 Compressor Oil

NOTICE

Risk of improper compressor lubrication. Can cause compressor and refrigerant system damage.

Failure to use oil types, viscosities and quantities recommended by the compressor manufacturer may reduce compressor life and void the compressor warranty.

- Do not mix polyolester (POE) and mineral based oils.
- Do not mix oils of different viscosities.
- Consult Vertiv technical support or the compressor manufacturer if questions arise.

Table 11.2 Compressor Oil Types for R-410A Refrigerant

Compressor Type	Oil Type
Copeland Scroll and Digital Scroll	POE Oil - ISO 32 Centistoke Viscosity ¹
1. Use Copeland POE Oil ULTRA 32-3MAF or other Copeland-approved oils.	
Source: DPN003950. Rev. 6	

NOTE: See [Additional Oil Requirements for Digital Scroll Compressors](#) on page 50 for additional oil based on the system's refrigerant charge.

11.7.2 Replacement Compressors

Replacement compressors are available through your Vertiv sales office. If the unit is under warranty, the replacement compressor must be obtained from and the original compressor returned to your local Vertiv sales office. Compressors are shipped in reusable packaging, and the original compressor should be returned in the same packaging.

11.7.3 Rotalock Valve on Digital Scroll Compressors



WARNING! Risk of explosive discharge of high pressure refrigerant. Can cause serious injury. Neutral and service ports on the rotalock valve do not have a valve core. Front seat the service valves and relieve pressure from the compressor before loosening a part or a component attached to the service valve. Follow local codes to properly reclaim refrigerant.

- The Neutral port remains open to the compressor side in all positions of the valve stem, see **Figure 11.1** below . A high pressure cut-out switch or low pressure switch/transducer will be connected to this port.
- The Service port is closed to the system when valve stem is back seated, see **Figure 11.1** below . It is open to the system as soon as the valve is adjusted away from the back seated position.

Figure 11.1 Rotalock Valve

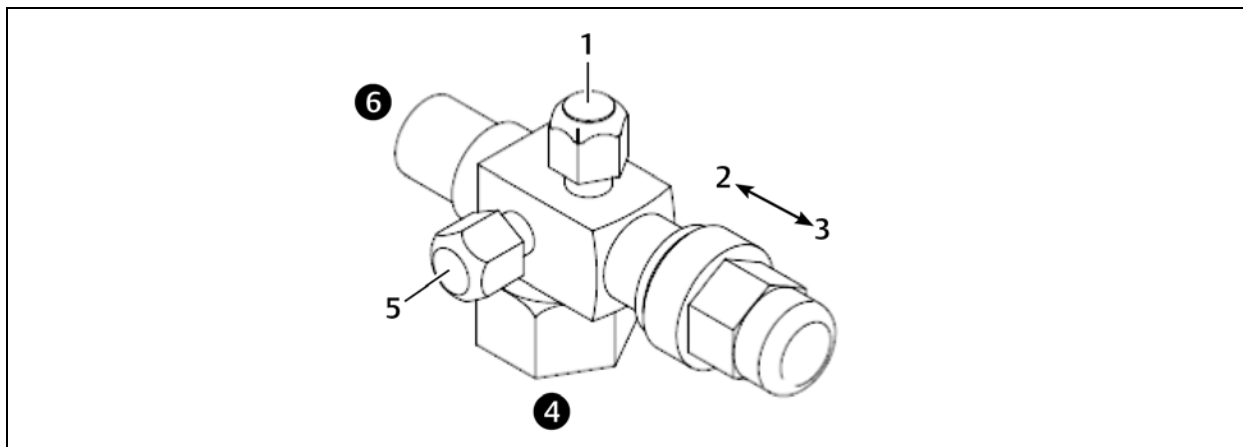

Item	Description
1	Service port (gauge)
2	Front seat
3	Back seat
4	Compressor side of valve
5	Neutral port
6	System side of valve

11.7.4 Unloading Solenoid(s) on a Digital Scroll Compressor

When replacing a digital scroll compressor, the digital solenoid valve and coil must be replaced. The compressor and valve kit are shipped separately. The valve kit must be field brazed to the top of the compressor in proper orientation and supported with the original factory bracket.

11.7.5 Compressor Electrical Failure (Motor Burnout)

If a burnout has occurred, a full system clean out is required. If not cleaned, compressor and system problems will continue.

Consult the factory for compressor maintenance. Do not attempt to remove the compressor without first contacting Vertiv support at 1-800-543-2778.

11.7.6 Replacing a Compressor with Electrical Failure (Motor Burnout)



WARNING! Risk of electric shock. Can cause serious injury or death. The Vertiv™ Liebert® iCOM™ microprocessor does not isolate power from the unit, even in the "Unit Off" mode. Some internal components require and receive power even during the "unit off" mode of the Liebert® iCOM™ control. Open all local and remote electric power disconnect switches and verify with a voltmeter that power is Off before working on any component of the system.



WARNING! Risk of over-pressurization of the refrigeration system. Can cause explosive discharge of high pressure refrigerant, loss of refrigerant, environmental pollution, equipment damage, injury, or death. This unit contains fluids and gases under high pressure. Use extreme caution when charging the refrigerant system. Do not pressurize the system higher than the design pressure marked on the unit's nameplate.

NOTE: Release of refrigerant to the atmosphere is harmful to the environment. Refrigerant must be recycled or discarded in accordance with federal, state, and local regulations.

1. Attach suction and discharge gauges to access fittings.
2. Front-seat service valves to isolate the compressor. Recover refrigerant using an approved recovery procedure and equipment. Use a filter drier when charging the system with recovered refrigerant.
3. Remove marked pressure transducer and discharge pressure switch. Disconnect all electrical connections.
4. Detach service valves from compressor.
5. Remove failed compressor.
6. Follow compressor manufacturer's suggested clean-out procedures.
7. Install replacement compressor and make all connections. Replace gaskets or seals on service valves. Replace unloading solenoid.
8. Evacuate, charge and operate per the appropriate procedure per local codes:
 - [Evacuation, Leak Testing, and Charging Air Cooled Systems without Receivers](#) on page 52
 - [Evacuation, Leak Testing, and Charging Air Cooled Systems with Liebert® Lee-Temp Flooded Condenser Head Pressure Control System](#) on page 58

NOTICE

Risk of improper component re-installation. Can cause equipment damage.

Identify and mark location of suction pressure transducer and discharge pressure switch. These devices look similar and they must be reinstalled in their original location.

11.7.7 Compressor Mechanical Failure

If mechanical failure of the compressor has occurred, only the compressor needs replaced. A full system clean out is not required.

11.7.8 Replacing a Compressor with Mechanical Failure



WARNING! Risk of electric shock. Can cause serious injury or death. The Liebert® iCOM microprocessor does not isolate power from the unit, even in the "Unit Off" mode. Some internal components require and receive power even during the "unit off" mode of the Liebert® iCOM control. Open all local and remote electric power disconnect switches and verify with a voltmeter that power is Off before working on any component of the system.



WARNING! Risk of over-pressurization of the refrigeration system. Can cause explosive discharge of high pressure refrigerant, loss of refrigerant, environmental pollution, equipment damage, injury, or death. This unit contains fluids and gases under high pressure. Use extreme caution when charging the refrigerant system. Do not pressurize the system higher than the design pressure marked on the unit's nameplate.

NOTE: Release of refrigerant to the atmosphere is harmful to the environment. Refrigerant must be recycled or discarded in accordance with federal, state, and local regulations.

1. Front seat service valves to isolate the compressor. Recover refrigerant using an approved recovery procedure and equipment
2. Remove failed compressor.
3. Keep the replacement compressor sealed until installation is complete to the point that the system isolation valves are ready to be engaged. Keep exposure of the POE oil in compressor to atmosphere to a minimum.
4. Install replacement compressor, replace gaskets or seals on service valves, and make all connections. Replace unloading solenoid if equipped.
5. Once the compressor is completely installed, keep isolation valves closed to the system and open to compressor. Add dry nitrogen to compressor and check all connections for leaks. With no leaks confirmed, evacuate the isolated compressor prior to introducing to the rest of the system.
6. When evacuating the isolated compressor volume, pull a vacuum of 500 microns with no decay above 1000 microns within 20 minutes.
Once evacuation requirements of compressor are met, open the valves to open the compressor to the system.
7. Check compressor and system operation. Make any necessary adjustments for proper equipment operation.

11.8 Inspect and Replace the Air Filters—600 mm (24 in.) Models

NOTE: Check the air filter monthly to maintain efficient air distribution through the evaporator coil.



WARNING! Risk of contact with high speed rotating fan blades. Can cause serious injury or death. Open all local and remote electric power-supply disconnect switches, verify with a voltmeter that power is off, and verify that all fan blades have stopped rotating before working in the unit cabinet or on the fan assembly. Fan motor controls can maintain an electric charge for 10 minutes after power is disconnected. If control voltage is applied, the fan motor can restart without warning after a power failure.

1. Switch Off the Liebert® CRV.
2. Open the rear panel by rotating the three locks with a screwdriver.
3. Wait until the fans stop rotating. When you open the first lock, you also open a safety switch that cuts the input power, see **Figure 11.2** below .

Figure 11.2 Air Filter Location and Input Power Safety Switch—600 mm (24 in.) Models

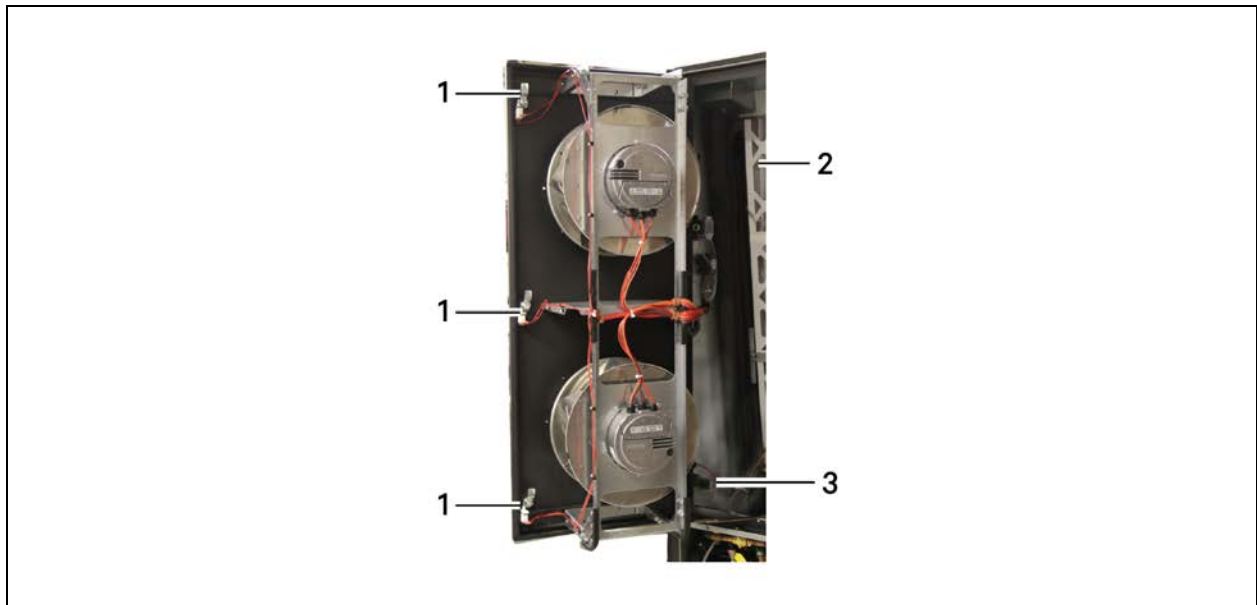

Item	Description
1	Safety switch
2	Air filter
3	Safety switch

To extract the filters, refer to [Remove the Air Filters—600 mm \(24 in.\) Models](#) on the next page :

1. Push up the upper filter.
2. Pull the bottom of the filter away from the unit.
3. Pull it out of the unit.
4. Lift the lower filter up

5. Pull the bottom of the filter away from the unit.
6. Pull it out of the unit.

Figure 11.3 Remove the Air Filters—600 mm (24 in.) Models

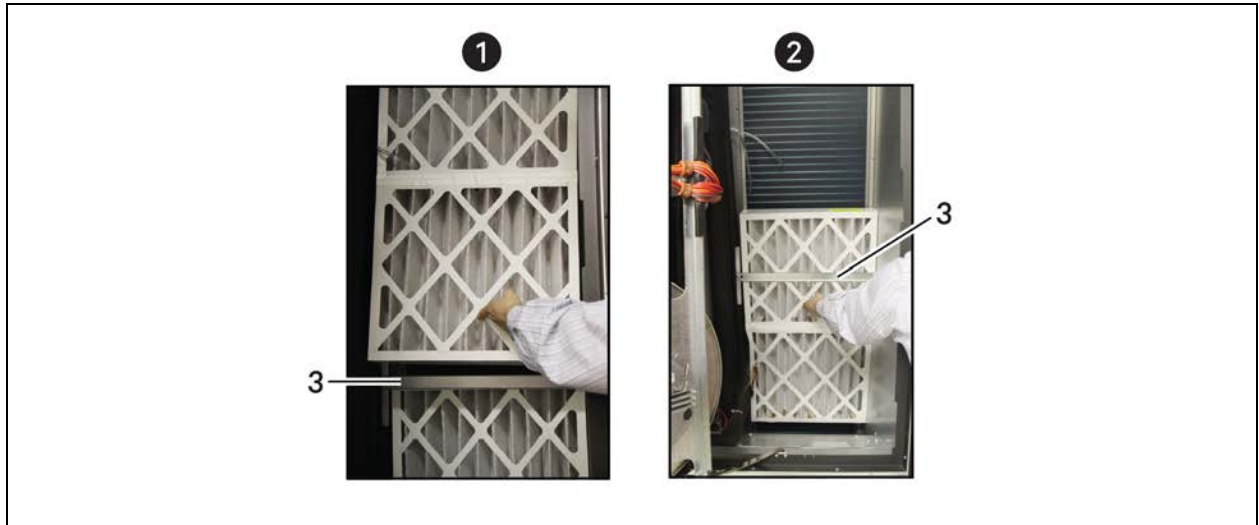

Item	Description
1	Upper filter removal
2	Lower filter removal
3	Support bar

After cleaning or replacing the filter and before reassembling the unit, check that the air differential pressure switch pipes (clogged filter alarm) are in the correct position and order. Check also that the drain trays are clean and the pipe secure.

NOTE: Before restarting the unit, be sure that the unit's door is properly closed. If it is ajar, the micro switches on the door will keep the unit in safety status.

Figure 11.4 Differential Pressure Switch Tubes—600 mm (24 in.) Models

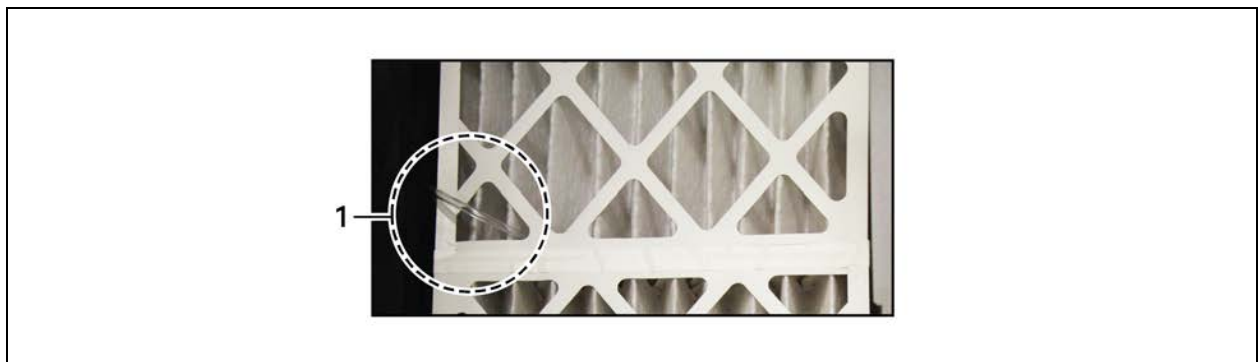

Item	Description
1	Differential pressure switch tube

11.9 Inspect and Replace the Air Filters—300 mm (12 in.) Models

NOTE: Check the air filter monthly to maintain efficient air distribution through the evaporator coil.

1. Switch Off the Liebert® CRV.
2. Remove the rear door by unlatching the two quarter-turn fasteners and lifting the door off. The filters are just inside the door.
3. If the filters appear dirty, depress the tabs on the right side of the upper filter and remove the filter.
4. Repeat step 3 for the lower filter.
5. Replace the lower filter by inserting the left edge into the rail and pushing the right side in until the tabs snap back out to retain the filter.
6. Repeat step 5 for the upper filter.

Figure 11.5 Remove the Air Filters 300 mm (12 in.) models

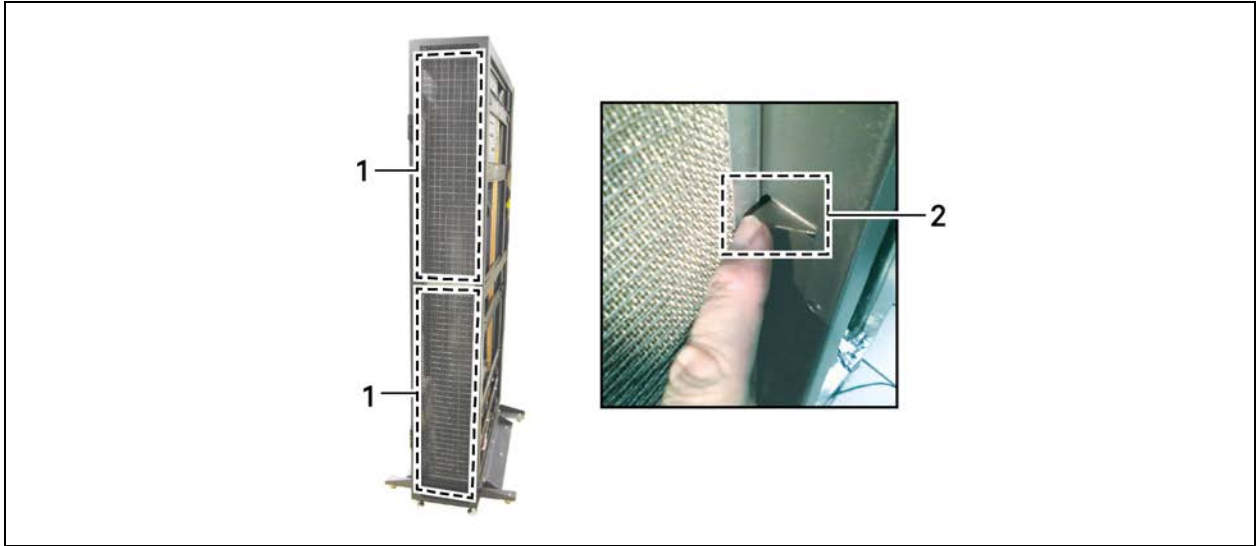

Item	Description
1	Air filter
2	Tab that secures filter in place

After cleaning or replacing the filter and before reassembling the unit, check that the air differential pressure switch tube (clogged filter alarm) are correctly installed. Also verify that the drain trays are clean and the pipe is secure.

Figure 11.6 Differential Pressure Switch Components, 300 mm (12 in.) models

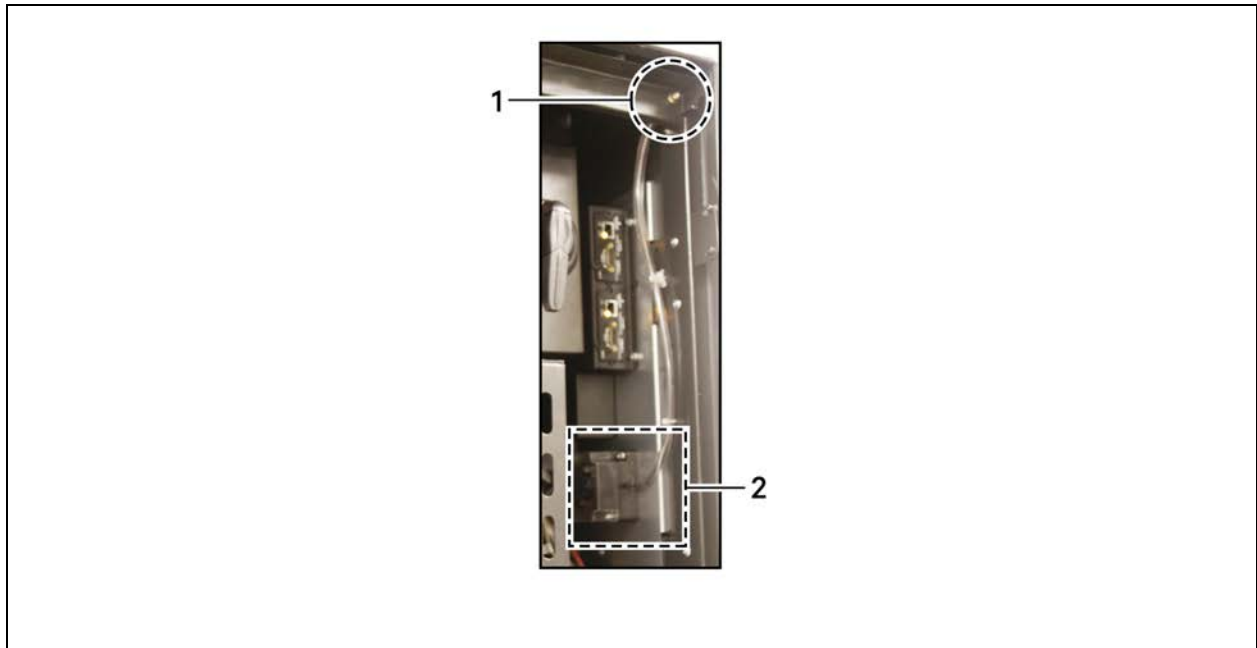

Item	Description
1	Differential pressure sampling point
2	Differential pressure switch

11.10 Condensate Drain and Condensate Pump System Maintenance

11.10.1 Condensate Drain

Check for and clear obstructions in tubing during routine maintenance.

11.10.2 Condensate Pump, Dual Float



WARNING! Risk of electric shock. Can cause injury or death. Open all local and remote electric power-supply disconnect switches and verify that power is Off with a voltmeter before working within the condensate pump electrical connection enclosure. The Liebert® iCOM™ does not isolate power from the unit, even in the “Unit Off” mode. Some internal components require and receive power even during the “Unit Off” mode of the Liebert® iCOM.

To maintain the condensate pump:

1. Disconnect power to the unit using the disconnect switch.
2. Check for and clear obstructions in gravity lines leading to the condensate pump.
3. Remove the sump, clean with a stiff nylon brush and flush with water.

Inspect and clear clogs in the discharge check valve and float mechanism.

4. Reassemble and check for leaks.

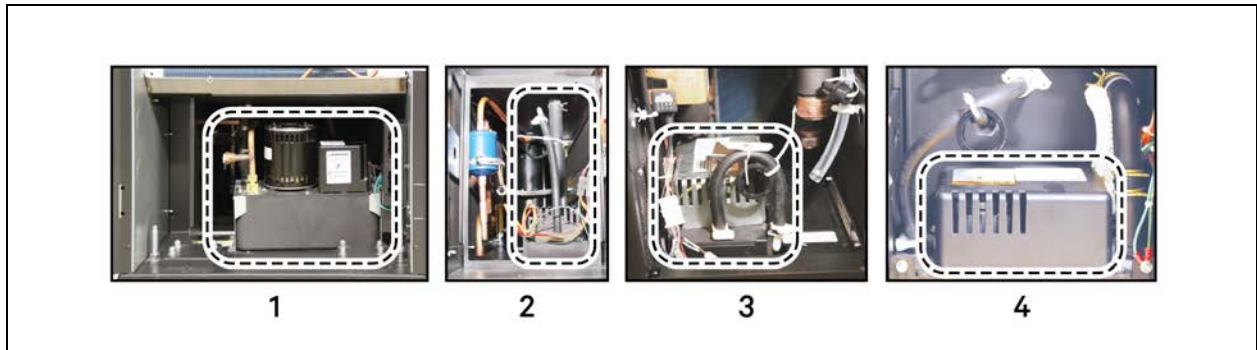
Figure 11.7 Condensate Pump Locations

Item	Description
1	600 mm (24 in.) unit, near the front of the unit
2	300 mm (12 in.), air cooled unit, near the front of the unit
3	300 mm (12 in.), chilled water unit, near the rear of the unit
4	300 mm (12 in.), water/glycol cooled unit, near the front of the unit

11.11 Air-Cooled Condenser and Drycooler Maintenance

Restricted airflow will reduce operating efficiency and could result in high compressor head pressure and loss of cooling.

- Clear coil surface of all debris that will inhibit airflow.
- Check for bent or damaged coil fins and correct.
- Do not permit snow to accumulate around or under outdoor unit.
- Periodically consider commercial cleaning of coil surface
- Inspect fans, motors and controls for proper operation.
- Check all piping and capillaries for proper support.
- Inspect for leaks.
- Check contactors for pitting. Replace if pitted.

11.12 Electric Reheat Maintenance

- Inspect and clean reheat elements.
- Inspect and tighten support hardware.

11.13 Fan Replacement

11.13.1 Replacing a Fan in 600 mm (24 in.) Models



WARNING! Risk of contact with high speed rotating fan blades. Can cause serious injury or death. Open all local and remote electric power-supply disconnect switches, verify with a voltmeter that power is off, and verify that all fan blades have stopped rotating before working in the unit cabinet or on the fan assembly. Fan motor controls can maintain an electric charge for 10 minutes after power is disconnected. If control voltage is applied, the fan motor can restart without warning after a power failure.

Refer to **Figure 11.8** below for the fan-assembly components.

To replace the fan:

1. Shut off all power to the unit by closing the main disconnect switch on the electrical panel on the rear of the Liebert® CRV.
2. Open the front door.
3. Open the panel assembly that contains the fans, using the quarter-turn latches.
4. Disconnect the fan's power connections in the electrical junction box.
5. Remove the fan frame assembly by removing the 4 bolts from the corner braces at each corner.
6. Set the fan assembly in a work area.
7. Remove the 4 bolts that attach the fan to be replaced to the frame assembly.
8. Reverse the steps to install the replacement fan.

Figure 11.8 Fan Assembly Components—600 mm (24 in.) Models

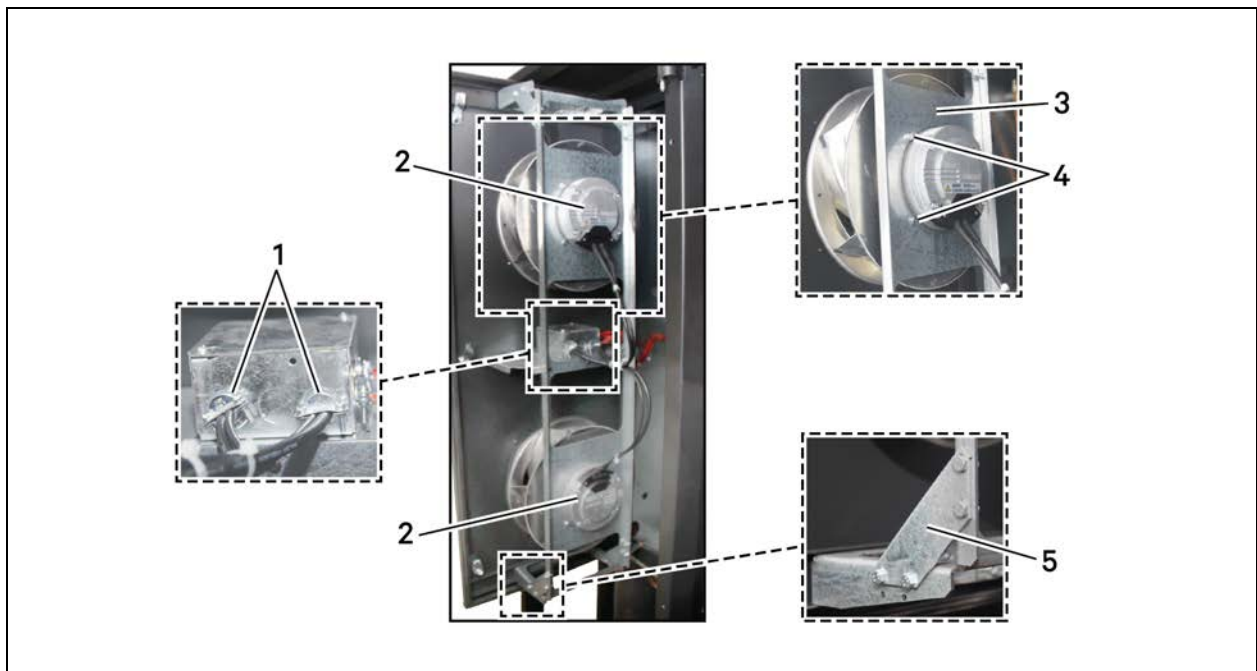

Item	Description
1	Wire entry into fan electrical-junction box
2	Fan
3	Mounting plate
4	Bolts, 2 on each side of fan, 4 total
5	Corner brace with 4 bolts

Figure 11.9 Fan Assembly Components for CR050 models.

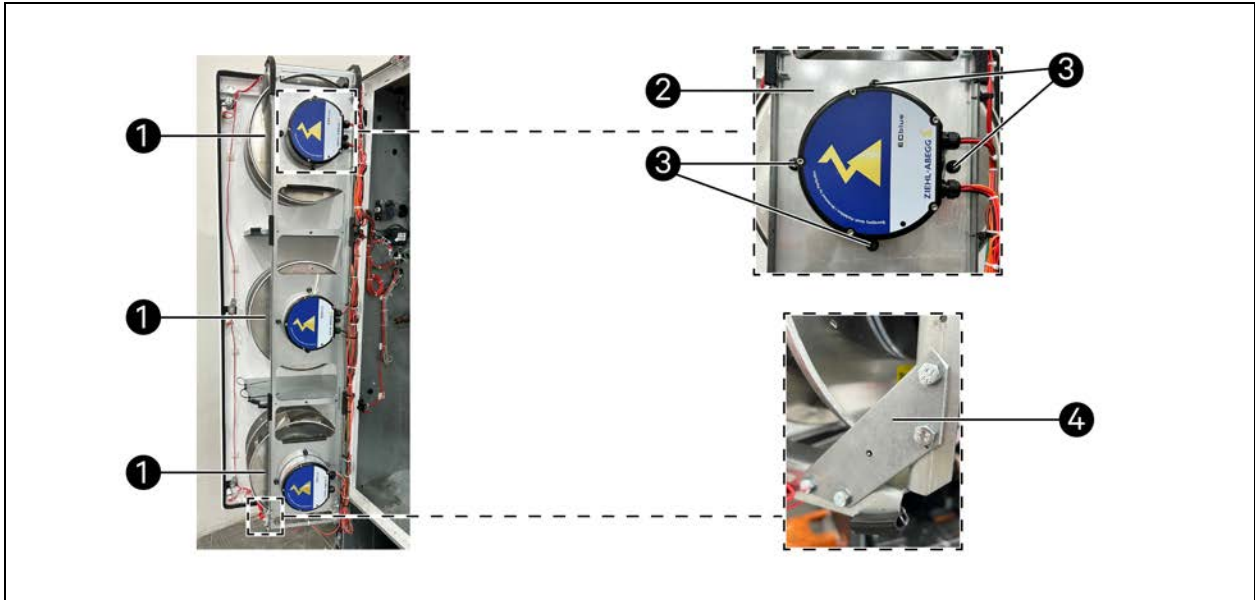

Item	Description
1	Fans
2	Mounting Plate
3	Bolts (4 for each fan)
4	Corner brace with 4 bolts

11.13.2 Replacing a Fan in 300 mm (12 in.) Models

! WARNING! Risk of contact with high speed rotating fan blades. Can cause serious injury or death. Open all local and remote electric power-supply disconnect switches, verify with a voltmeter that power is off, and verify that all fan blades have stopped rotating before working in the unit cabinet or on the fan assembly. Fan motor controls can maintain an electric charge for 10 minutes after power is disconnected. If control voltage is applied, the fan motor can restart without warning after a power failure.

Refer to **Figure 11.10** on the next page for the fan assembly components.

1. Shut off all power to the unit by closing the main disconnect switch on the electrical panel on the rear of the Liebert® CRV.
2. Open the front door.

3. Disconnect the fan high voltage 3 pin connector and low voltage 4 pin plug connector
4. Remove the 2 lower screws securing the fan assembly to the unit's frame. There is 1 screw in each corner.
5. Loosen the top screws on the fan assembly. There is 1 screw in each corner.
6. Lift the assembly up and out of the unit.
7. Set the fan assembly in a work area.
8. Reverse the steps to install the replacement fan.

Figure 11.10 Fan Assembly components—300 mm (12 in.) models

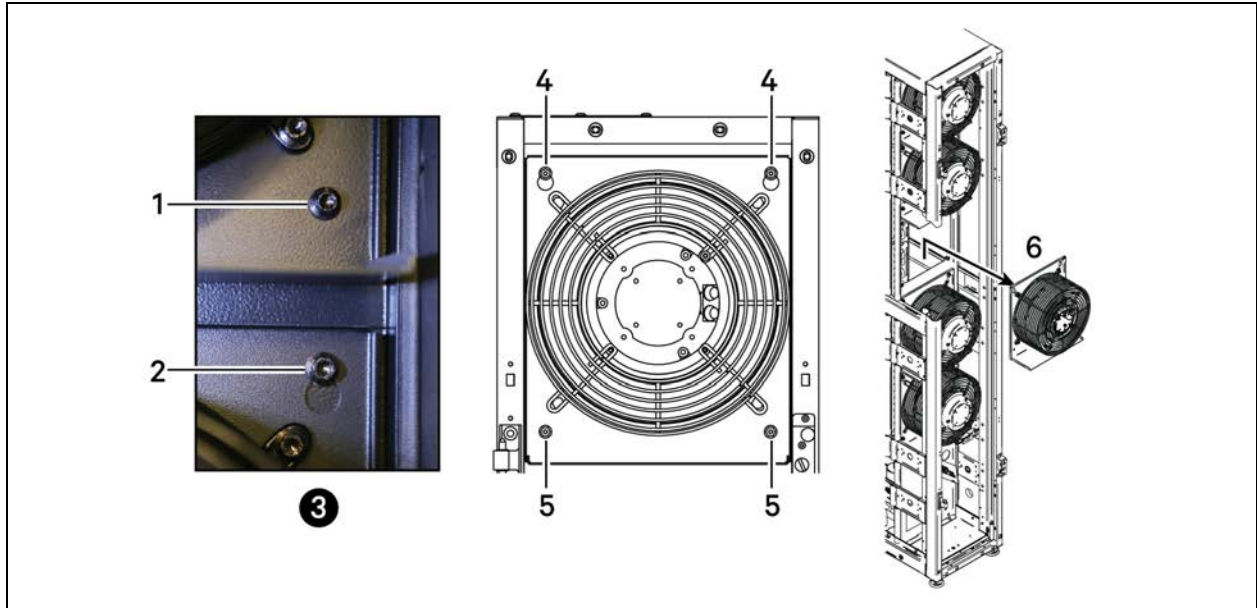

Item	Description
1	Screw in bottom half of upper fan assembly
2	Screw in keyhole slot in top half of lower fan assembly
3	Intersection of two fan assemblies
4	Upper screw in keyhole slot
5	Lower screws
6	Lift the fan assembly up and out of the unit.

11.14 Considerations when Dismantling the Unit

The Liebert® CRV is designed and built to ensure continuous operation.

The working life of some of the main components, such as the fan and the compressor, depends on proper maintenance.

NOTICE

Risk of release of hazardous substances into the environment. Can cause environmental pollution and violation of environmental regulations.

The Liebert® CRV contains substances and components hazardous for the environment (electronic components, refrigerating gases and oils). At the end of its useful life, the Liebert® CRV must be dismantled by specialized refrigerating technicians. The unit must be delivered to suitable centers specializing in the collection and disposal of equipment containing hazardous substances.

The refrigerating fluid and the lubricating oil inside the circuit must be recovered according to the laws in the relevant country.

To recover the gas, use all the connections described in [Vacuum Refrigerant Charge Connection Locations](#) on page 49 .

This page intentionally left blank

12 Preventive Maintenance Worksheet

Source: DPN002954, Rev. 1

Inspection Date	Job Name
Indoor Unit Model #	Indoor Unit Serial Number #
Condenser/Drycooler Model #	Condenser/Drycooler Serial #
Room Temperature/Humidity ° %	Ambient Temperature °

Not all units will have all components. To determine your unit’s configuration, compare the [Indoor Unit Model #](#) above and the information in the Components and Nomenclature section.

Good maintenance practices are essential to minimizing operation cost and maximizing product life. Read and follow all applicable maintenance checks listed below. At a minimum, these checks should be performed semi-annually. However, maintenance intervals may need to be more frequent based on site-specific conditions. Review the unit user manual for further information on unit operation. We recommend the use of trained and authorized service personnel, extended service contracts, and factory-certified replacement parts. Contact your local sales representative for more details.

Check all that apply:

Evaporator/Filters

- 1. Check/replace filters
- 2. Grille area unrestricted
- 3. Wipe section clean
- 4. Coil clean
- 5. Clean condensate pan
- 6. Clean trap in condensate drain
- 7. Check/test filter clog switch operation (if equipped)

Reheat (if equipped)

- 1. Inspect elements
- 2. Check wire connections (inside reheat box)
- 3. Reheat amp draw

L1	L2	L3
----	----	----

Steam Generating Humidifier (if equipped)

- 1. Check drain valve/drain lines/trap for damage/clogs/leaks
- 2. Check water fill valve and all supply lines/connection for leaks
- 3. Check condition of steam hose
- 4. Clean strainer
- 5. Replace humidifier bottle if necessary
- 6. Check operation of humidifier
- 7. Humidifier amp draw

L1	L2	L3
----	----	----

Condensate Pump (if equipped)

1. Check for debris in sump
2. Check operation of float(s) (free movement)
3. Check/clean discharge check valve

Electrical Panel

1. Check fuses
2. Check contactors for pitting (Replace if pitted)
3. Check/re-torque wire connections

Controls

1. Check/verify control operation (Sequence)
2. Check/test changeover device(s) (if equipped)
3. Check/test water-detection device(s) (if equipped)
4. Check/test CAN connection between indoor and outdoor units (if equipped)

Refrigeration Piping

1. Check refrigerant lines (clamps secure/no rubbing/no leaks)
2. Check for moisture (sight glass)
3. Check for restriction temperature drop across filter drier

Compressor Section (if equipped)

1. Check oil level
2. Check for oil leaks
3. Check compressor mounts (springs/bushings)
4. Cap tubes (not rubbing)
5. Check/re-torque wire connections (inside compressor box)
6. Compressor operation (vibration/noise)
7. Check crank case heater fuses/operation (if equipped)
8. Check for refrigerant leaks

9. Suction pressure	Circuit #1
10. Discharge Pressure	Circuit #1
11. Superheat	Circuit #1
12. Low pressure switch cut out	Circuit #1
13. Low pressure cut in	Circuit #1
14. High pressure cut out	Circuit #1

15. Amp draw

L1	L2	L3
----	----	----

Water Cooled Condensers (if equipped)

1. Verify proper water maintenance/treatment is being performed
2. Check water-regulating valve (motorized ball valve) operation
3. Verify water flow
4. Clean screen on Y strainer (if equipped)
5. Cap tubes (not rubbing)
6. Check condenser and supply/return lines/connections for water/glycol leaks
7. Entering water temperature _____°
8. Leaving water temperature _____°

Drycooler (if equipped)

1. Coil clean free of debris
2. Motor mounts tight
3. Bearings in good condition (motor)
4. Piping support/clamps secure
5. Check/Re-torque wire connections
6. Check contactors for pitting (replace if pitted)
7. Check fuses
8. Verify fan operation
9. Check surge-protection device status indicator lights (if equipped)
10. Stat Settings _____
11. Glycol level
12. Glycol solution -----%
13. Water/Glycol solution flowing continuously/clean and free of debris
14. Water-treatment plan established and followed for open cooling-tower application
15. Check refrigerant/glycol lines for signs of leaks/repair as found
16. Motor amp draw

#1	L1	L2	L3
#2	L1	L2	L3
#3	L1	L2	L3
#4	L1	L2	L3
#5	L1	L2	L3
#6	L1	L2	L3
#7	L1	L2	L3
#8	L1	L2	L3
#9	L1	L2	L3
#10	L1	L2	L3

Liebert® MC Condenser (if equipped)

1. Coil clean
2. Fans free of debris
3. Fans securely mounted
4. Motor bearings in good condition
5. Check all refrigerant lines for vibration isolation. Support as necessary
6. Check for refrigerant leaks
7. Check surge-protection device (if installed) status-indicator lights
8. Check/Re-torque wire connections
9. Check contactors for pitting (replace if pitted)
10. Verify operation sequence/set points
11. Charge verification:
 - a. Outdoor Ambient Temperature -----
 - b. Subcooling -----
 - c. Indoor-unit Return-air Temperature -----
 - d. Sight-glass level (if Lee-Temp or pumped refrigerant) -----
12. Motor amp draw

#1	L1	L2	L3
#2	L1	L2	L3
#3	L1	L2	L3
#4	L1	L2	L3

Glycol Pump

1. Check pump rotation
2. Check pump and supply/return lines/connections for leaks
3. Pump pressures

#1	Suction	Discharge
#2	Suction	Discharge
#3	Suction	Discharge

4. Amp Draw

#1	L1	L2	L3
#2	L1	L2	L3
#3	L1	L2	L3

5. Verify pump changeover (if multiple pumps)

This page intentionally left blank

Appendices

Appendix A: Technical Support and Contacts

A.1 Technical Support/Service in the United States

Vertiv Group Corporation

24x7 dispatch of technicians for all products.

1-800-543-2378

Liebert® Thermal Management Products

1-800-543-2378

Liebert® Channel Products

1-800-222-5877

Liebert® AC and DC Power Products

1-800-543-2378

A.2 Locations

United States

Vertiv Headquarters

505 N. Cleveland Ave.

Westerville, OH 43082, USA

Europe

Via Leonardo Da Vinci 8 Zona Industriale Tognana

35028 Piove Di Sacco (PD) Italy

Asia

7/F, Dah Sing Financial Centre

3108 Gloucester Road

Wanchai, Hong Kong

This page intentionally left blank

Appendix B: Model Number Nomenclature Detail

CRV Model Number Digit Definitions (continued) on page 129 describes each digit of the 25 digit configuration number. The 14 digit model number consists of the first 10 digits and last four digits of the configuration number.

Table B.1 Liebert CRV 25 Digit Configuration Number Example

Model # Part 1										Model Details											Model # Part 2			
1	2	3	4	5	6	7	8	9	10	11	12	13	14	15	16	17	18	19	20	21	22	23	24	25
C	R	0	2	0	R	A	1	C	7	S	H	1	8	1	1	E	L	1	0	P	A	—	—	—

Table B.2 CRV Model Number Digit Definitions

Digit	Description
Digits 1 and 2 = Unit Family	CR = Liebert® CRV
Digits 3-5 - Nominal Capacity, kW	019 = DX (300 mm [12 in.] wide) 020 = DX (600 mm [24 in.] wide) 035 = DX (600 mm [24 in.] wide) 032 = CW (300 mm [12 in.] wide) 040 = CW (600 mm [24 in.] wide) 050 = CW (600 mm [24 in.] wide)
Digit 6 - Row-Based, Unit Depth	R = 1100 mm (43.4 in.)
Digit 7 - System Type	A = Air-Cooled W = Water/Glycol-Cooled C = Chilled Water-Cooled
Digit 8 - Fan Type	1 = Variable Speed EC fans
Digit 9 - Power Supply	A = 460V / 3ph / 60Hz (600 mm [24 in.]) C = 208V / 3ph / 60Hz (600 mm [24 in.]) Y = 208-230V / 3ph / 60Hz (300 mm [12 in.]) P = 208-230V / 1ph / 60Hz (300 mm [12 in.]); Control transformer can be tapped to provide 240V/1ph/60Hz K = 120V / 1ph / 60Hz (300 mm [12 in.]) 3 = 460V / 3ph / 60Hz-Wye with Neutral required (300 mm [12 in.])
Digit 10 - Cooling System	2 = Two-Way Valve (CW Models Only) 3 = Three-way Valve (CW Models Only)

Table B.2 CRV Model Number Digit Definitions (continued)

Digit	Description
	<p>7 = R-410A Digital Scroll (Air-Cooled and 600 mm [24 in.] W/G)</p> <p>4 = Top Connections Only (300 mm [12 in.] W/G only)</p> <p>5 = Bottom Connections Only (300 mm [12 in.] W/G only)</p>
Digit 11 - Humidifier	<p>0 = None</p> <p>S = Steam Generating Canister (600 mm [24 in.] models only)</p>
Digit 12 - Control System	<p>1 = Liebert® iCOM™ 2 (9 inch touch color screen display)</p>
Digit 13 - Reheat	<p>0 = None</p> <p>1 = Electric Reheat (600 mm [24 in.] models only)</p>
Digit 14 - Air Filter	<p>A = 2-in. MERV 8 (300 mm [12 in.] models only)</p> <p>C = 1/2-in. MERV 1 and Clog Filter Switch (300 mm [12 in.] models only)</p> <p>8 = 4-in. MERV 8 + Clogged Filter Switch (600 mm [24 in.] models only)</p> <p>9 = 4-in. MERV 11 + Clogged Filter Switch (600 mm [24 in.] models only)</p>
Digit 15 - Water/Glycol Valve Type	<p>1 = Two-Way Valve (W/G only) OR Default Air-Cooled Selection</p> <p>7 = Three-Way Valve (W/G only)</p> <p>H = Default CW Selection</p>
Digit 16 - Enclosure	<p>1 = No Certification; Standard Color (Z-7021 Black)</p> <p>3 = Seismic Certification Level 1 (Sd = 0.8); Standard Unit Without Internal Bracing; Standard Color (Z-7021 Black)</p> <p>4 = Seismic Certification Level 2 (Sd = 2.0/2.5) With Internal bracing; Standard Color (Z-7021 Black)</p>
Digit 17 - High Voltage Options	<p>L = No condensate pump, 5k SCCR, 300 mm (12 in.) 120-V CW Only</p> <p>5 = Condensate pump, 5k SCCR, 300 mm (12 in.) 120-V CW Only</p> <p>M = No dual-float condensate pump (for units without humidifier), 65k SCCR</p> <p>P = Dual-float condensate Pump (for units with or without humidifier), 65k SCCR</p>
Digit 18 - Option Package	<p>0 = None</p> <p>H = Reheat and Humidifier Lockout Contact (600 mm [24 in.] Only)</p> <p>C = Reheat and Humidifier Lockout and Additional Alarm Contact (600 mm [24 in.] Only)</p> <p>D = Low Sound Package (600 mm [24 in.] DX Only)</p> <p>L = Low Sound Package and Reheat and Humidifier Lockout and Additional Alarm Contact (600 mm [24 in.] DX Only)</p>

Table B.2 CRV Model Number Digit Definitions (continued)

Digit	Description
Digit 19 - Liebert® IntelliSlot™ Housing 0 = No Cards C = (1) Liebert® SiteLink-E™ Card U = (1) Liebert® IntelliSlot Unity DP™ Card 6 = (1) Liebert® IntelliSlot Unity DP Card and (1) Liebert® SiteLink-E™ Card 7 = (2) Liebert® IntelliSlot Unity DP Cards	
Digit 20 - Future Options 0 = None	
Digit 21 - Packaging With Ramp P = Domestic S = Export (Seaworthy)	
Digit 22 - Special Features A = No SFAs, Standard Unit X = SFA Included	
Digits 23-25 - Factory Configuration Number	

This page intentionally left blank

Appendix C: Submittal Drawings

The submittal drawings are in the order of document part number (DPN). **Table C.1** on the next page, groups the drawings by topic/application.

Table C.1 Submittal Drawings Contents

Document Number	Title
Component Planning Drawings	
DPN003738	Component Location Diagram, 600mm (24in.) Models
DPN003583	Component Location Diagram, 300mm (12in.) Air Cooled Models
DPN003585	Component Location, 300mm (12in.) Water Glycol Cooled Models
DPN003584	Component Location, 300mm (12in.) Chilled Water Models
Dimension Planning Drawings	
DPN001791	Cabinet Dimensional Data 600 mm (24 in.) Models
DPN002807	Cabinet Dimensional Data 300 mm (12 in.) Models
Piping Schematics and Connection Locations —Air Cooled Systems	
DPN002858	General Arrangement Diagram 600 mm (24 in.) Air Cooled with Liebert® MC Models
DPN002808	General Arrangement Diagram 300 mm (12 in.) Air Cooled with Liebert® MC Models
DPN003954	Air Cooled Piping Schematic Condenser Above Indoor Unit
DPN001792	Primary Connection Locations CR020RA & CR035RA Air Cooled Models
DPN002813	Primary Connection Locations 300 mm (12 in.) Air Cooled Models
Piping General Arrangement Drawings—Water/Glycol Cooled Systems	
DPN001985	General Arrangement Diagram 600 mm (24 in.) Water/Glycol Cooled Models
DPN003039	General Arrangement Diagram, 300 mm (12 in.) Water/Glycol Cooled Models
DPN001793	Primary Connection Locations CR020RW & CR035RW Water/Glycol Models
DPN003040	Primary Connection Locations 300 mm (12 in.) Water/Glycol Cooled Models
Piping General Arrangement Drawings—Chilled Water Systems	
DPN001986	General Arrangement Diagram 600 mm (24 in.) Chilled Water Models
DPN002976	General Arrangement Diagram 300 mm (12 in.) Chilled Water Models
DPN001794	Primary Connection Locations CR040 Chilled Water Models
DPN002814	Liebert® IntelliSlot Cable Connection Paths Liebert® IntelliSlot Wiring Routing Top of Unit 300 mm (12 in.) all Models
DPN002815	Primary Connections 300 mm (12 in.) Chilled Water Models
Electrical Field Connections 600 mm (24 in.) Models	
DPN001884	Electrical Field Connections Descriptions, 600 mm (24 in.) Models
DPN002841	CANbus & Interlock Connections between 60 mm (24 in.) Unit & Liebert® MC Condenser

Table C.1 Submittal Drawings Contents (continued)

Document Number	Title
Electrical Field Connection Drawings 300 mm (12 in.) Models	
DPNO02810	Electrical Field Connections Descriptions, 300 mm (12 in.) Models
DPNO03036	CANbus & Interlock Connections between 300 mm (12 in.) Unit & Liebert® MC (Premium)
DPNO03588	Low Voltage Field Wiring Routing, 300 mm (12 in.) All Models
DPNO03589	Power Cable Routing Bottom Entry, 300 mm (12 in.) Air Cooled & Water Glycol Cooled Models
DPNO03590	Power Cable Routing Bottom Entry 300 mm (12in.) Chilled Water Models

COMPONENT LOCATION DIAGRAM 600mm (24in.) MODELS

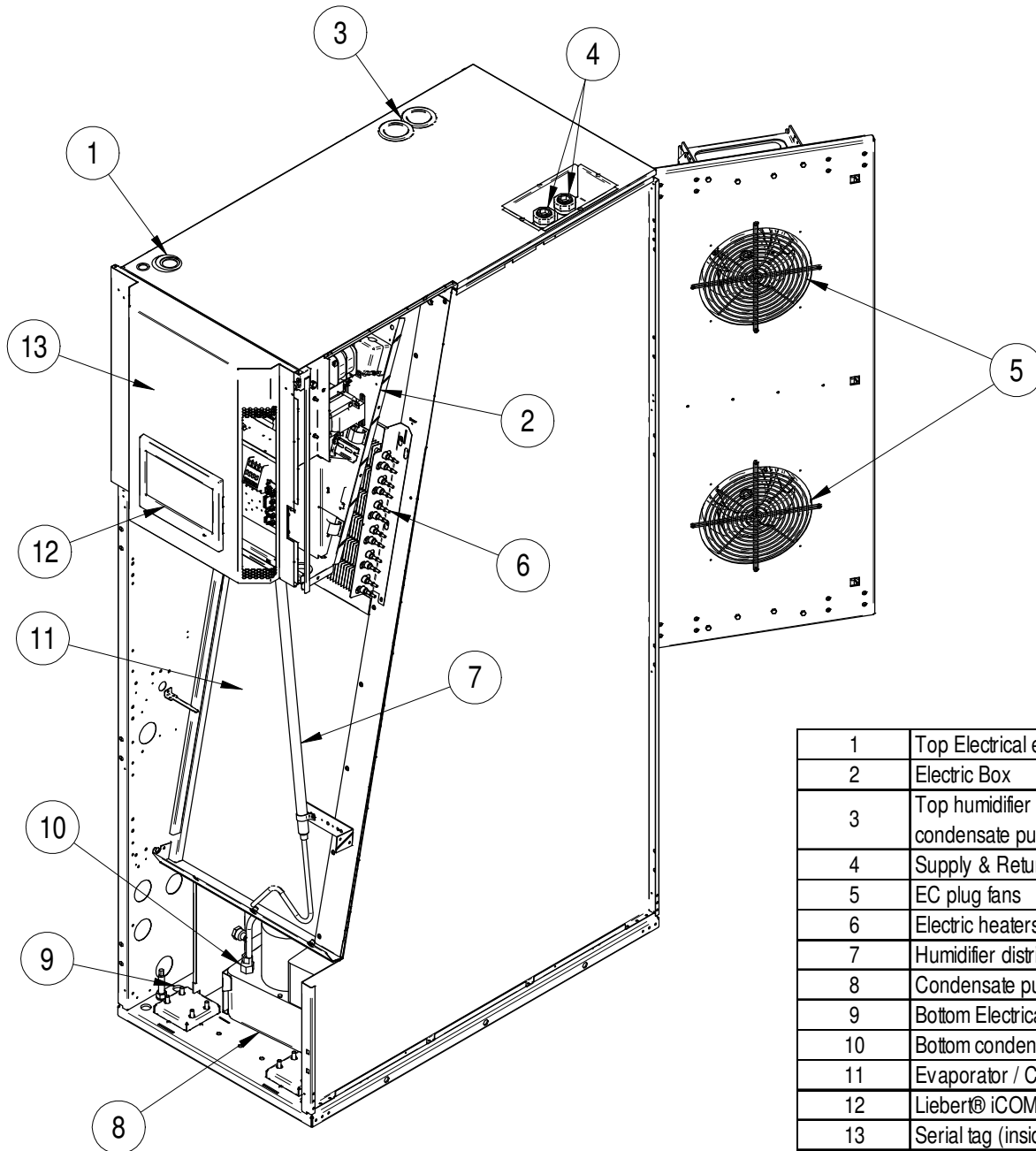

1	Top Electrical entrance
2	Electric Box
3	Top humidifier water supply, condensate pump drain
4	Supply & Return connections
5	EC plug fans
6	Electric heaters
7	Humidifier distributor
8	Condensate pump
9	Bottom Electrical entrance
10	Bottom condensate pump drain
11	Evaporator / CW coil
12	Liebert® iCOM™ Display
13	Serial tag (inside door)

LIEBERT® CRV

COMPONENT LOCATION 300mm (12in.) AIR COOLED MODELS

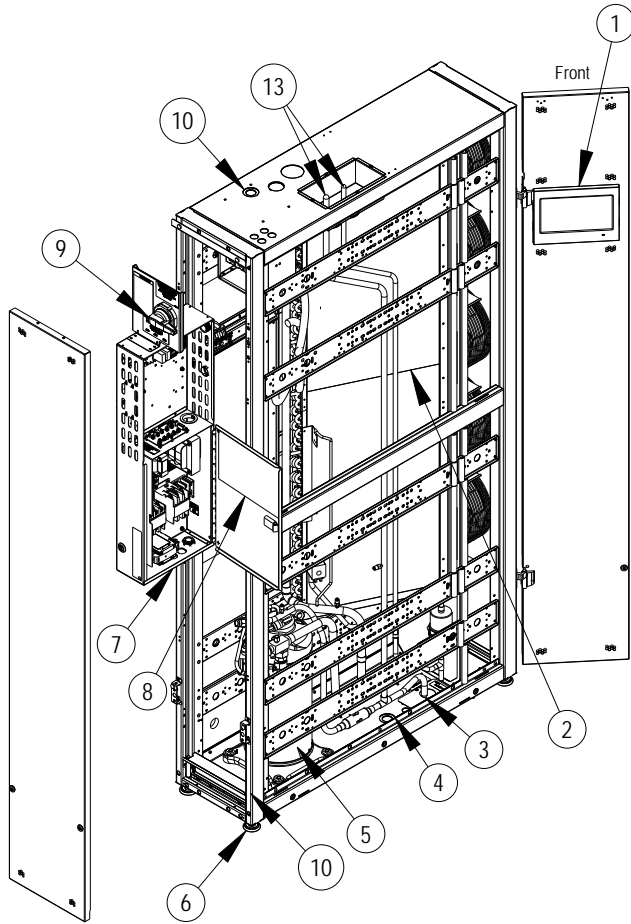

1	Liebert® iCOM™ Display
2	Evaporator Coil
3	Refrigerant piping connections & Condensate 10 Pump Drain (Bottom)
4	Electrical connection(Bottom)
5	Compressor
6	Caster & Leveling Foot(each corner)
7	Electric Box
8	Serial Tag
9	Main Disconnect Switch
10	Top Electrical Entrance
11	Air Baffles
12	EC Plug Fans
13	Top Refrigerant Connections

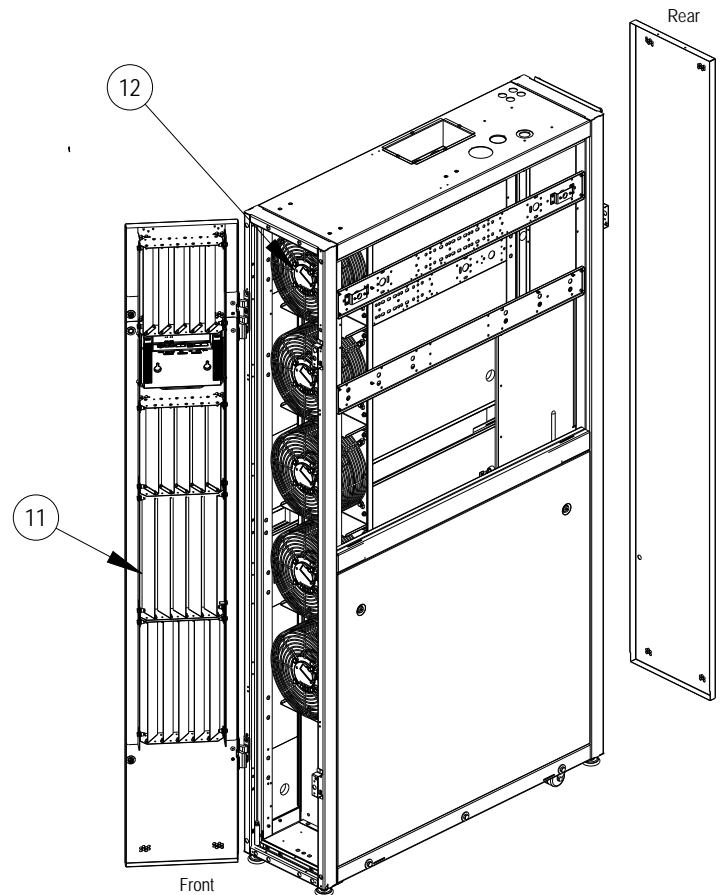

COMPONENT LOCATION 300mm (12in.) WATER GLYCOL COOLED MODELS

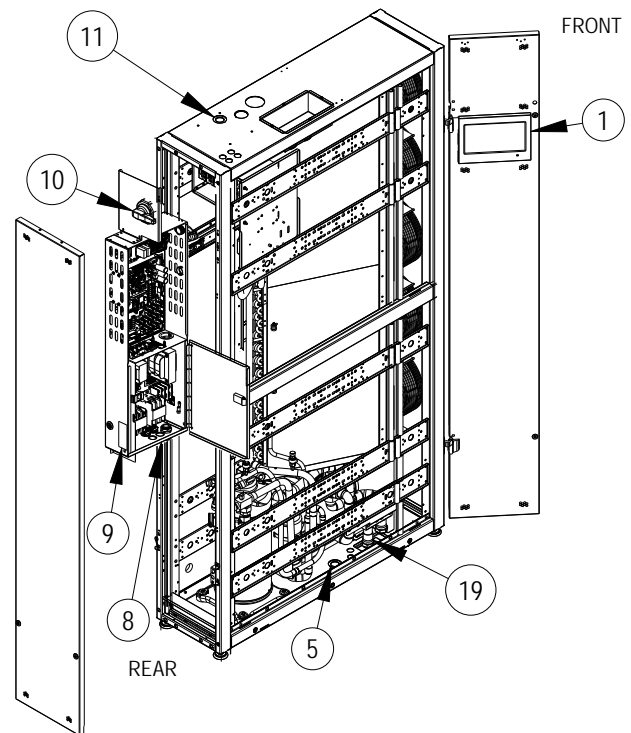
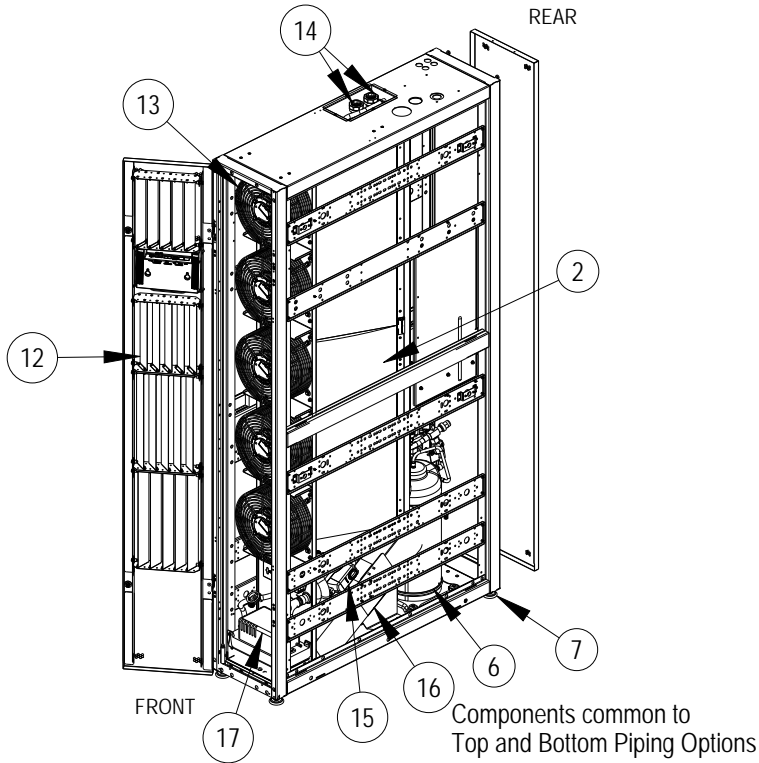
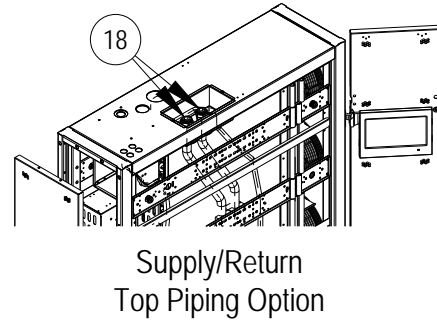
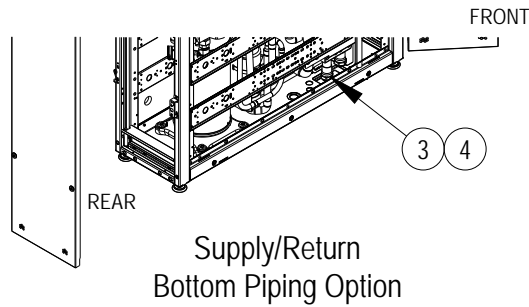

1	Liebert® iCOM™ Display	11	Top Electrical Entrance
2	Evaporator Coil	12	Air Baffles
3	Supply/Return Connections (Bottom Piping Option)	13	EC Plug Fans (5 typ.)
4	Knockouts for Supply/Return (Bottom Piping Option)	14	Condensate Pump Drain Top Connection
5	Bottom Electrical Entrance	15	Control Valve
6	Compressor	16	Heat Exchanger (Plate)
7	Caster & Leveling Foot (Each Corner)	17	Condensate Pump
8	Electric Box	18	Supply/Return Connections (Top Piping Option)
9	Serial Tag	19	Condensate Pump Drain Bottom Connection
10	Main Disconnect Switch		

LIEBERT® CRV

COMPONENT LOCATION 300mm (12in.) CHILLED WATER MODELS

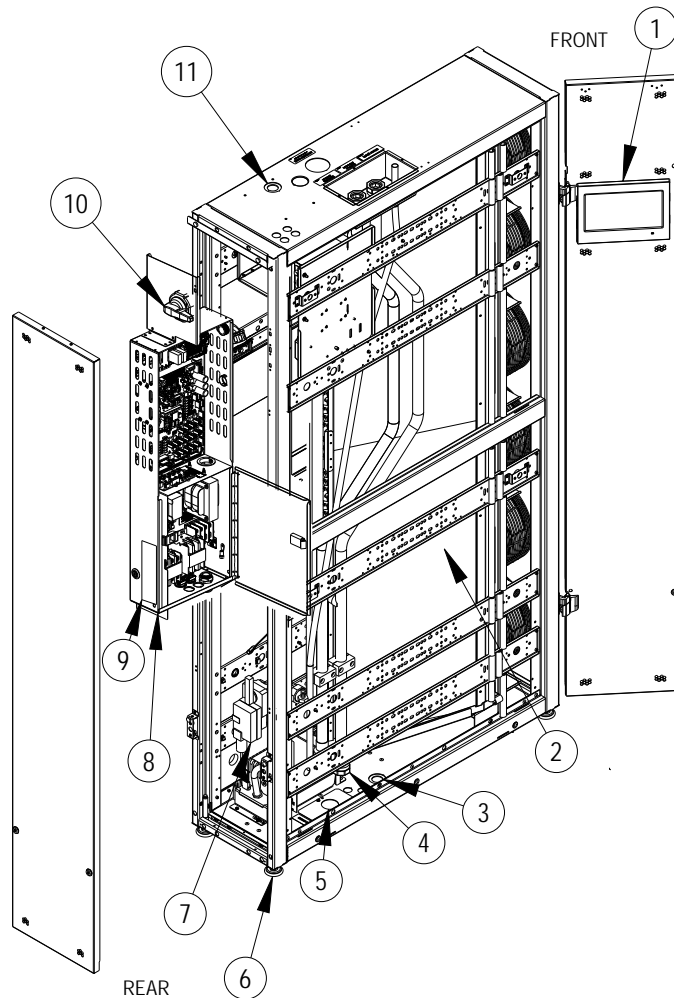

1	Liebert® iCOM™ Display
2	Cooling Coil
3	Knockouts for Bottom Electrical Entrance
4	Supply/Return Piping Connections (Bottom)
5	Bottom Chilled Water and Condensate Pump Drain Connections
6	Caster & Leveling Foot (each corner)
7	Chilled Water Valve (2 or 3-way valve)
8	Electric Box
9	Serial Tag
10	Main Disconnect Switch
11	Electrical connection (Top)
12	Air Baffles
13	EC Plug Fans (Typical 6)
14	Top Chilled Water and Condensate Pump Drain Connections

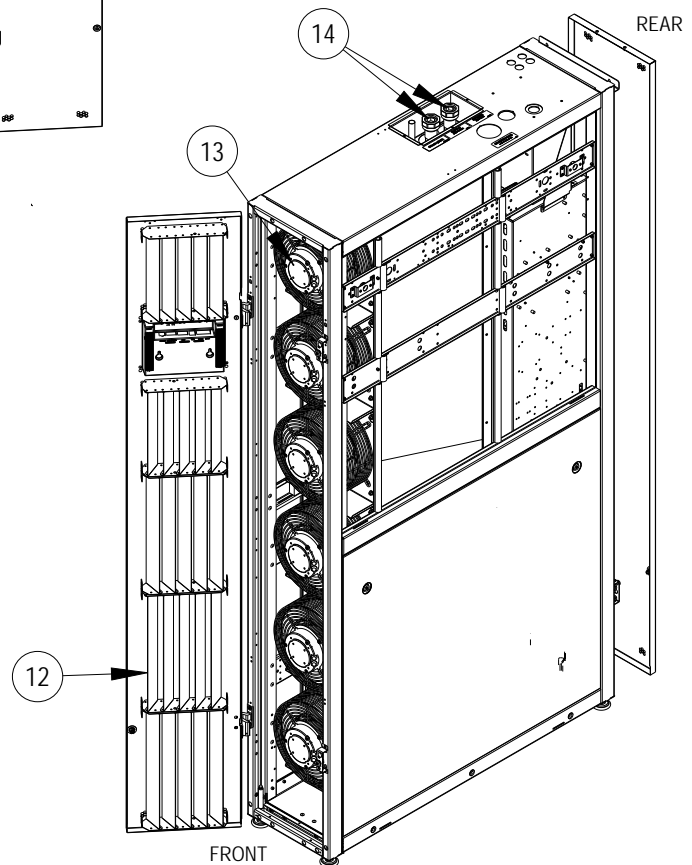

CABINET DIMENSIONAL DATA 600mm (24in.) MODELS

ACCESS REQUIRED TO SERVICE THE LIEBERT® CRV UNIT WITHIN THE ROW
REAR SERVICE AREA IS S+B OR S+A WHEN B IS NOT AVAILABLE

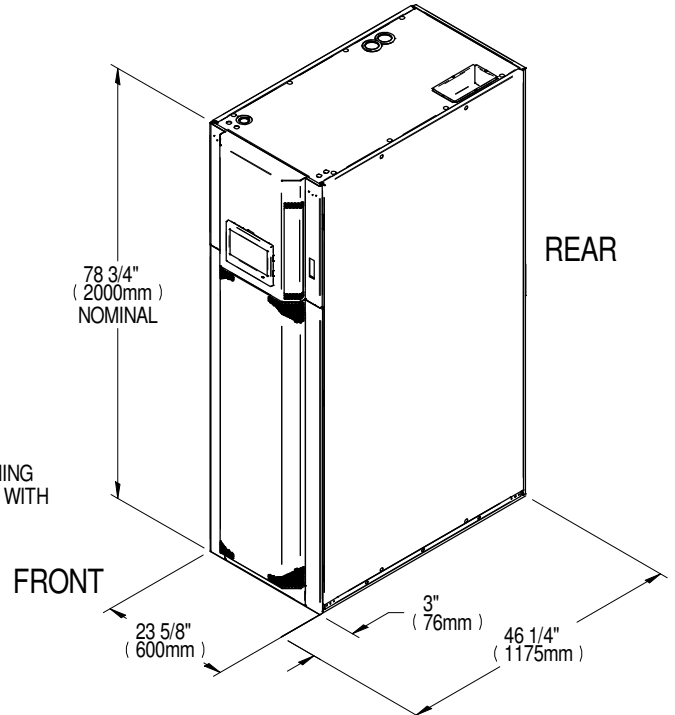
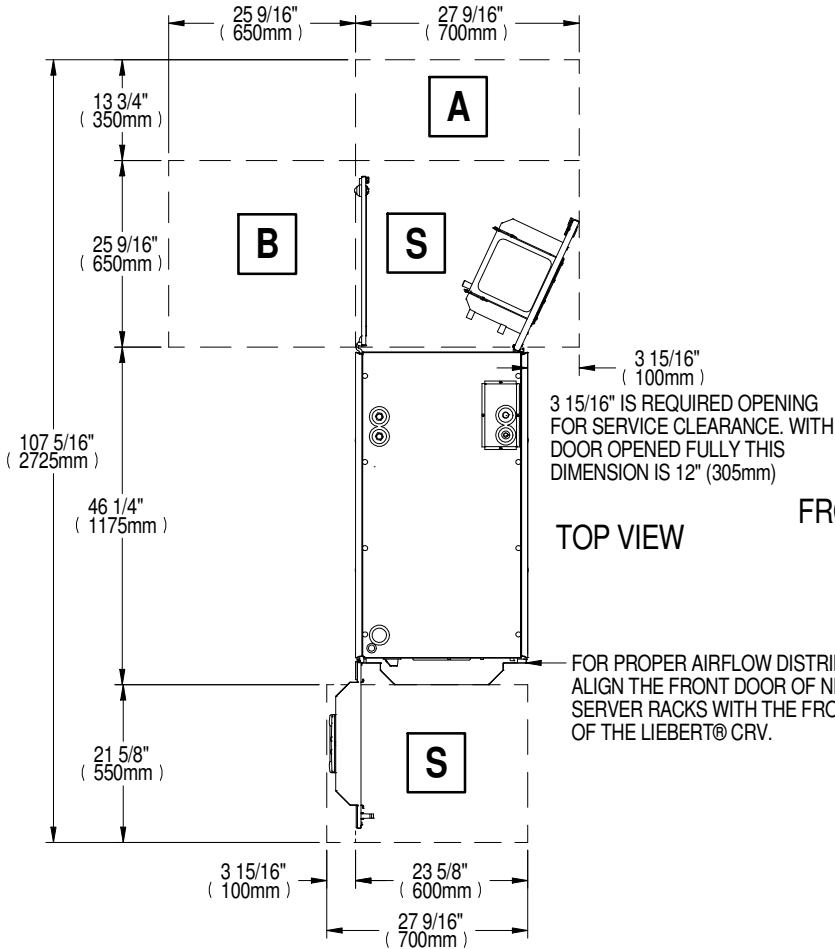

FOR PROPER AIRFLOW DISTRIBUTION:
ALIGN THE FRONT DOOR OF NEIGHBORING
SERVER RACKS WITH THE FRONT CORNER
OF THE LIEBERT® CRV.

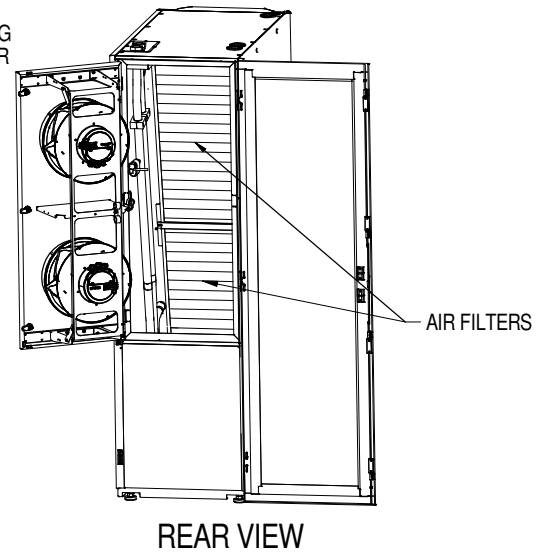

ACCESS REQUIRED FOR INSTALLATION OF
THE LIEBERT® CRV UNIT WITHIN THE ROW.

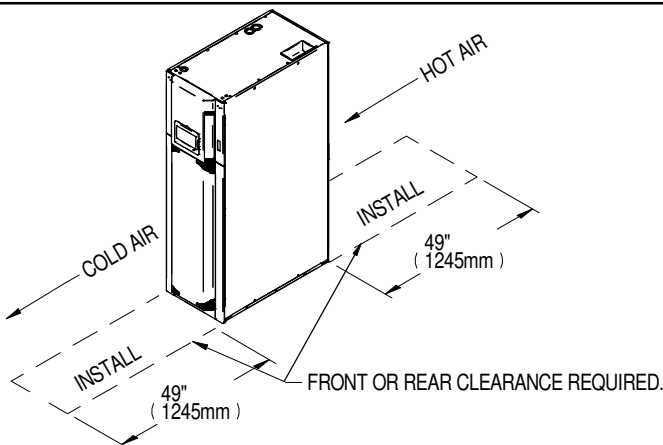

DRY WEIGHT ±5% - Lbs (kg)			
MODEL	AIR COOLED	WATER/GLYCOL	CHILLED WATER
CR020R	739 (335)	772 (350)	N/A
CR035R	805 (365)	849 (385)	
CR040R	N/A	N/A	728 (330)

CABINET DIMENSIONAL DATA 600mm (24in.) MODELS

ACCESS REQUIRED TO SERVICE THE LIEBERT® CRV UNIT WITHIN THE ROW
REAR SERVICE AREA IS S+B OR S+A WHEN B IS NOT AVAILABLE

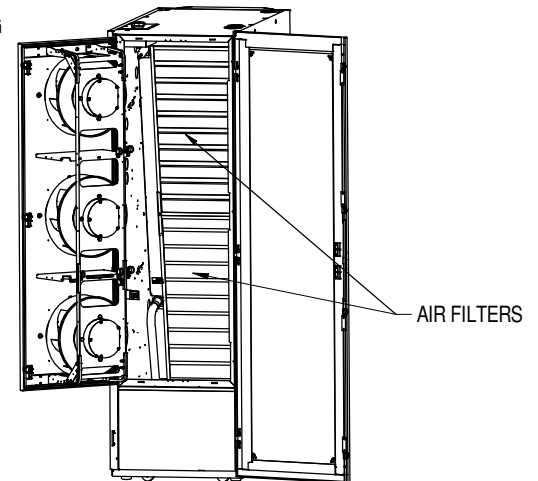
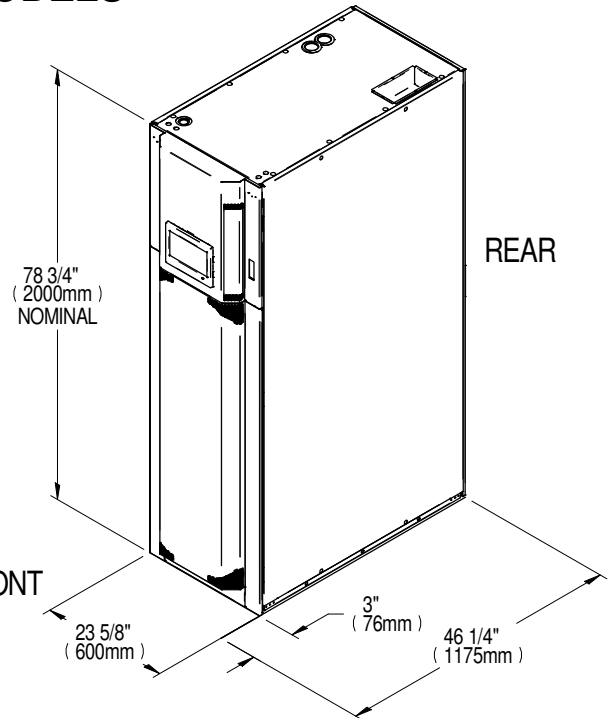
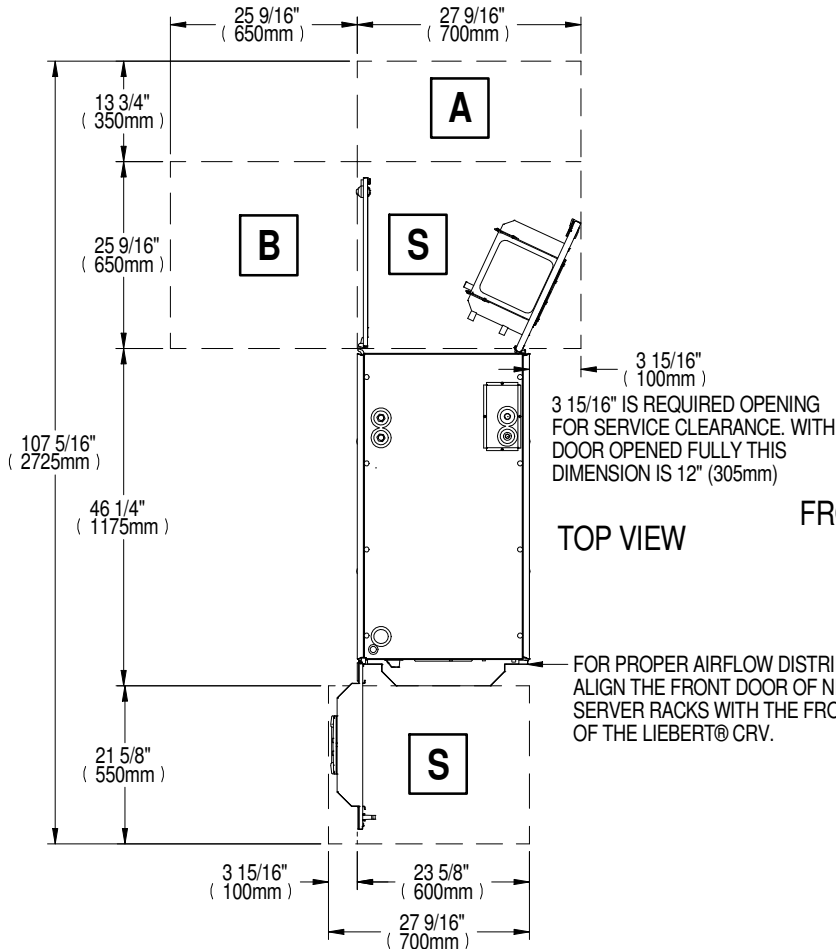

ACCESS REQUIRED FOR INSTALLATION OF THE LIEBERT® CRV UNIT WITHIN THE ROW.

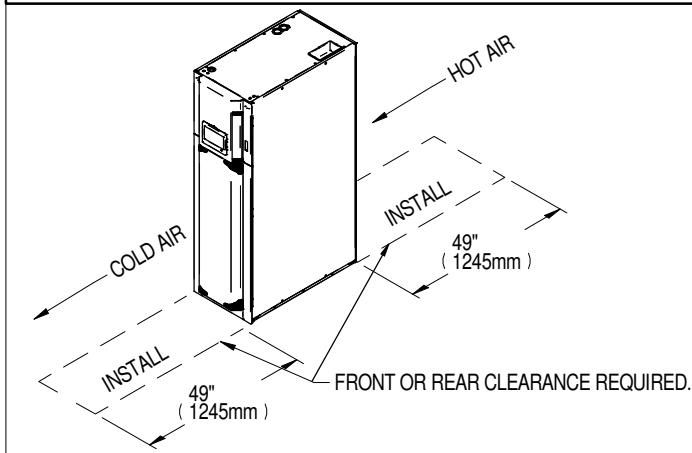

DRY WEIGHT ±5% - Lbs (kg)

MODEL	AIR COOLED	WATER/GLYCOL	CHILLED WATER
CR050R	N/A	N/A	754 (342)

CABINET DIMENSIONAL DATA 300mm (12in.) MODELS

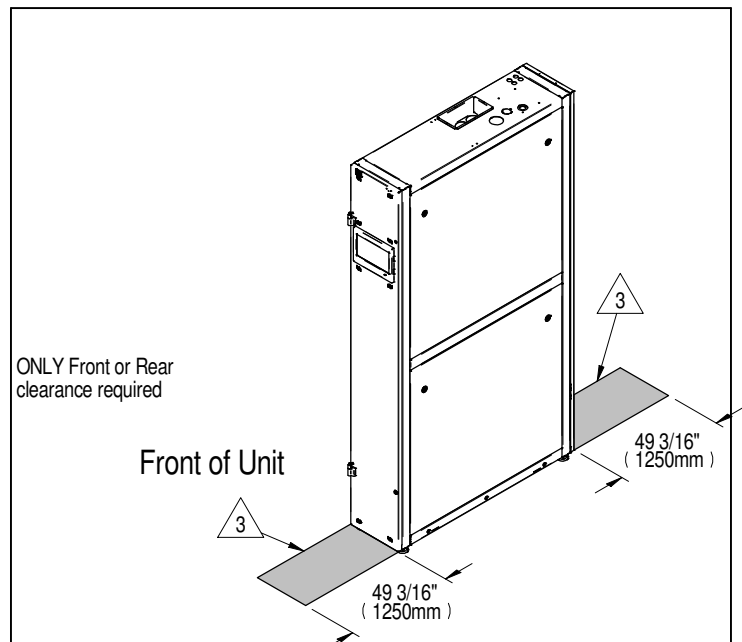
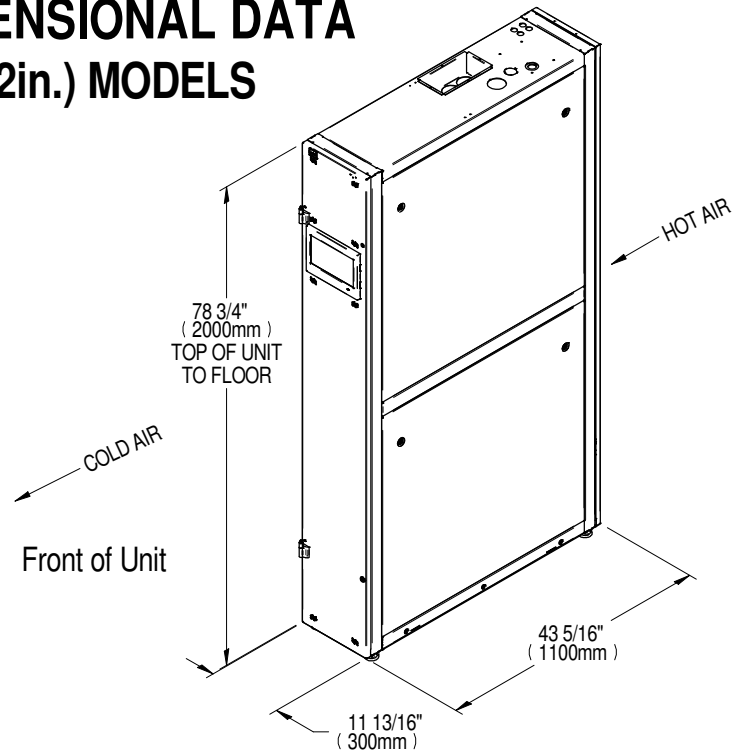
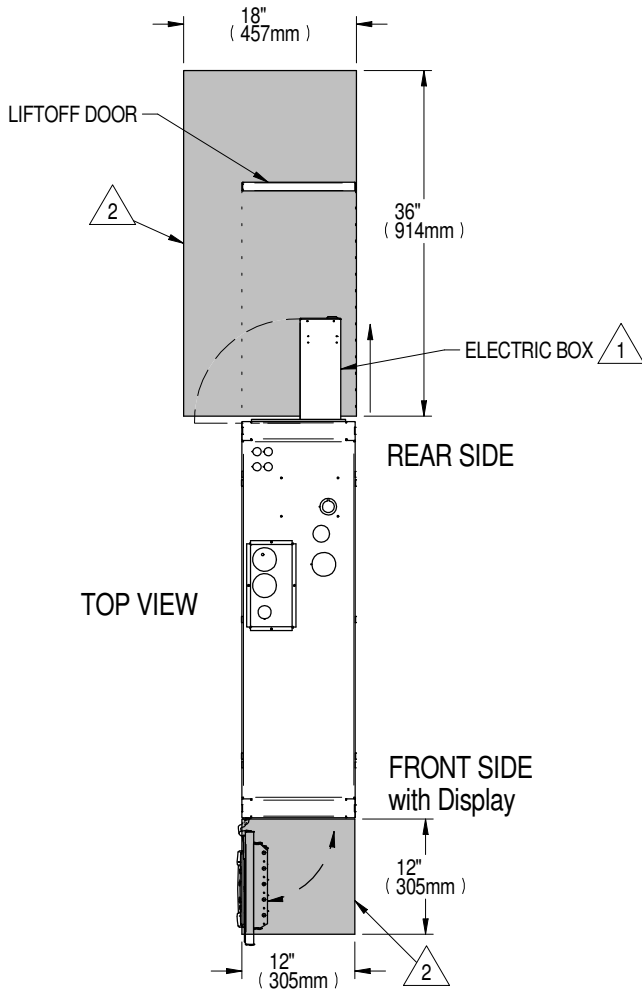

NOTES:

1. ELECTRIC BOX IS IN REAR OF UNIT (SHOWN FULLY EXTENDED). FOR SERVICE ACCESS TO ELECTRIC BOX REMOVE REAR DOOR. SLIDE ELECTRIC BOX REARWARD IN DIRECTION OF ARROW. ELECTRIC BOX DOOR SWINGS OPEN AS SHOWN. REAR EDGE OF UNIT MUST BE FLUSH WITH ADJACENT CABINET WITH REAR DOOR INSTALLED.
2. SHADED AREAS INDICATE ACCESS REQUIRED TO SERVICE THE ELECTRICAL AND MECHANICAL COMPONENTS OF THE UNIT BETWEEN EXISTING RACKS WITHIN THE ROW.
3. SHADED AREAS INDICATE ACCESS REQUIRED TO INSTALL THE UNIT BETWEEN EXISTING RACKS WITHIN THE ROW.

Cooling System	Dry Weight, +/- 5% lbs (kg)
AIR	507 (230)
WTR/GLY	545 (247)
CW	418 (190)

GENERAL ARRANGEMENT DIAGRAM 600mm (24in.) AIR COOLED W/ LIEBERT® MC MODELS

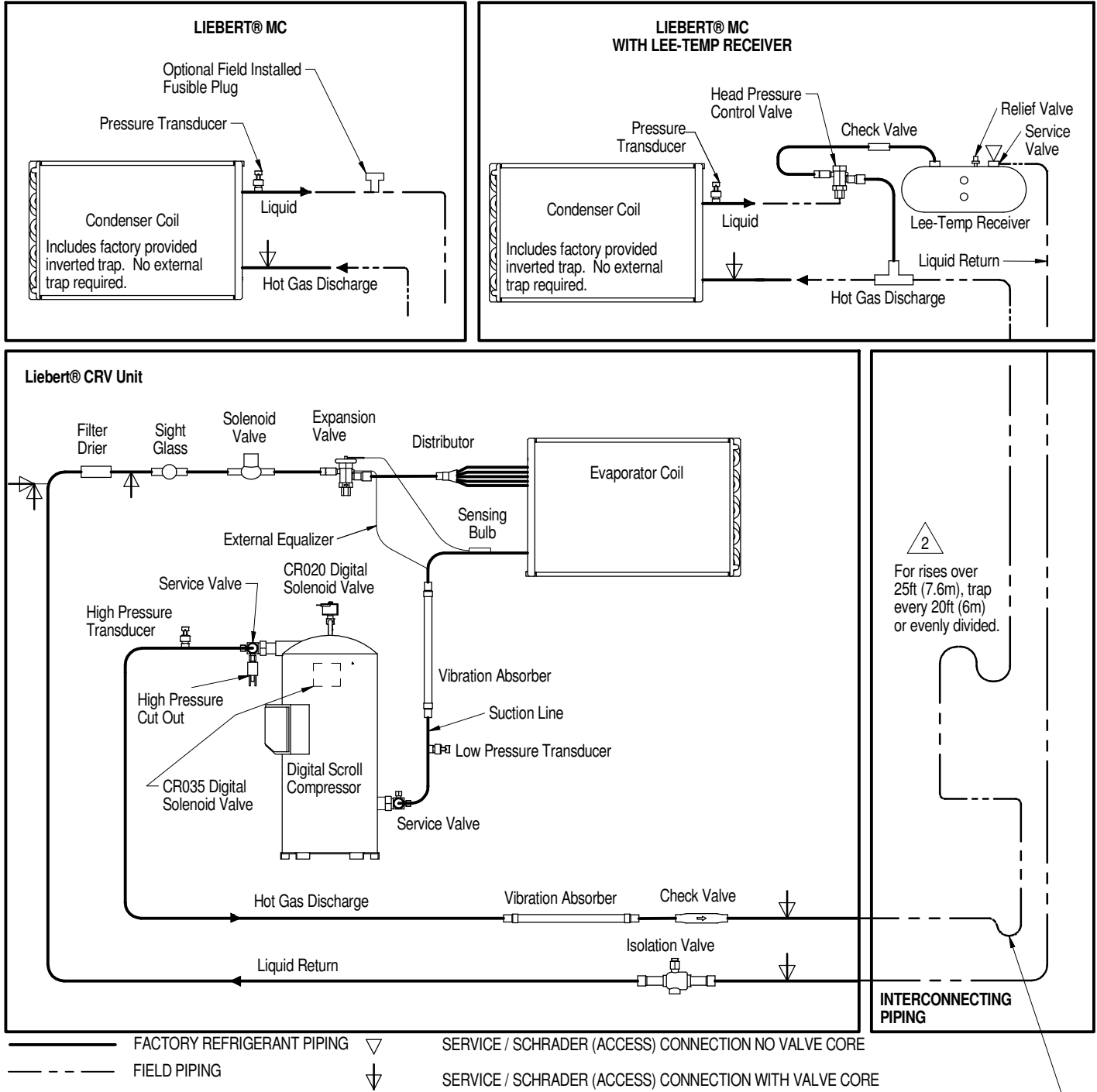

Notes:

- Schematic representation shown. Do not use for specific connection locations.
- Components are not supplied by Vertiv™, but are required for proper circuit operation and maintenance. Liebert® CRV has an internal trap at the base of the unit. For field piping the discharge line vertical rise starts at the base of the unit and not the top of the unit.
- Do not isolate any refrigerant circuit from over pressurization protection.
- Traps must be installed and horizontal lines pitched to ensure proper oil return and to reduce liquid floodback to compressor. Pitch horizontal hot gas piping at a minimum of 1/2" per 10 feet (42mm per 10m) so that gravity will aid in moving oil in the direction of the refrigeration flow.

GENERAL ARRANGEMENT DIAGRAM 300mm (12in.) AIR COOLED W/ LIEBERT® MC MODELS

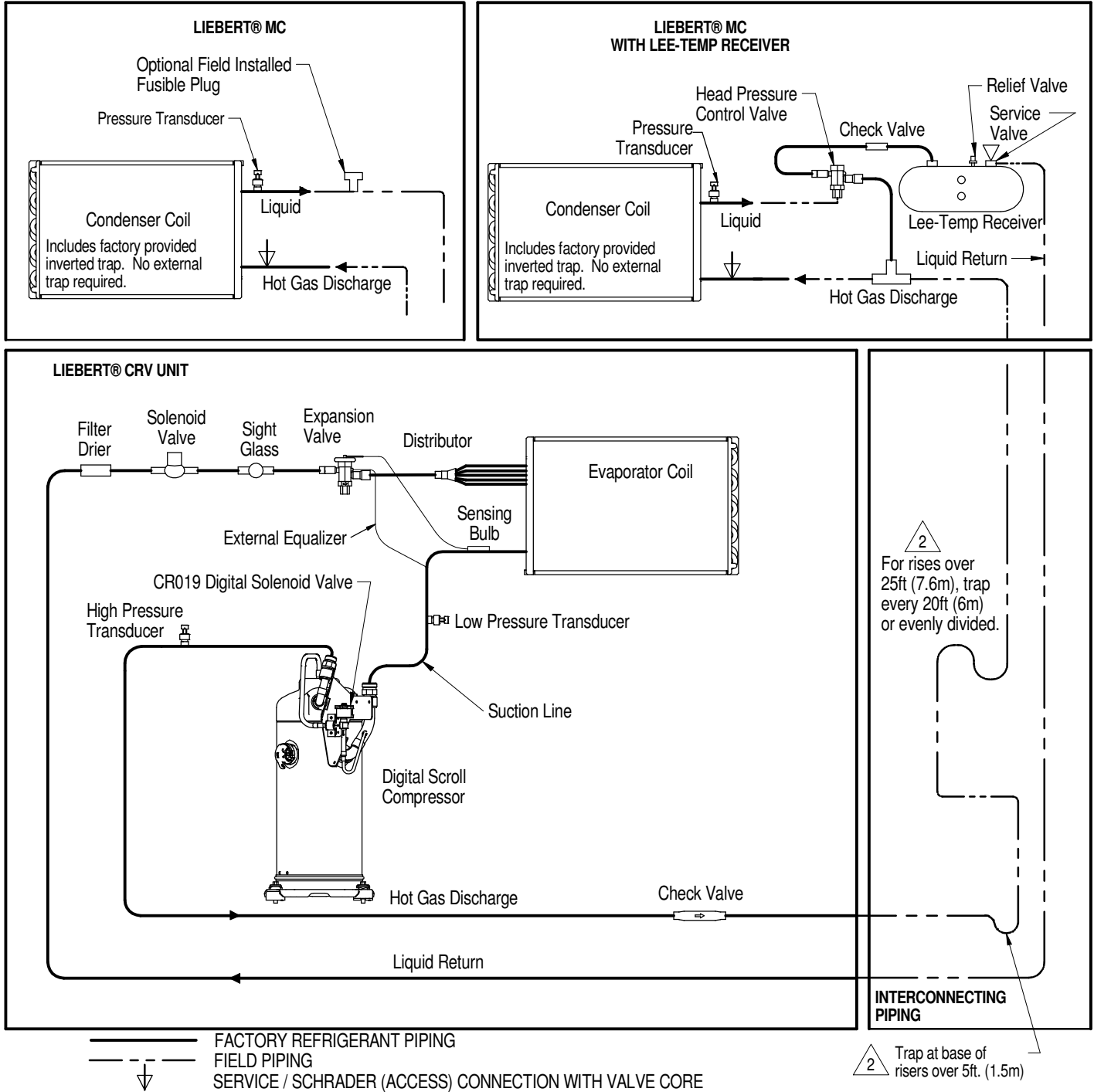

Notes:

1. Schematic representation shown. Do not use for specific connection locations.

2. Components are not supplied by Vertiv™, but are required for proper circuit operation and maintenance. Liebert® CRV has an internal trap at the base of the unit. For field piping, the discharge line vertical rise starts at the base of the unit and not at the top.

3. Do not isolate any refrigerant circuit from over pressurization protection.

4. Traps must be installed and horizontal lines pitched to ensure proper oil return and to reduce liquid floodback to compressor. Pitch horizontal hot gas piping at a minimum of 1/2" per 10 feet (42mm per 10m) so that gravity will aid in moving oil in the direction of the refrigeration flow.

AIR COOLED PIPING SCHEMATIC CONDENSER ABOVE INDOOR UNIT

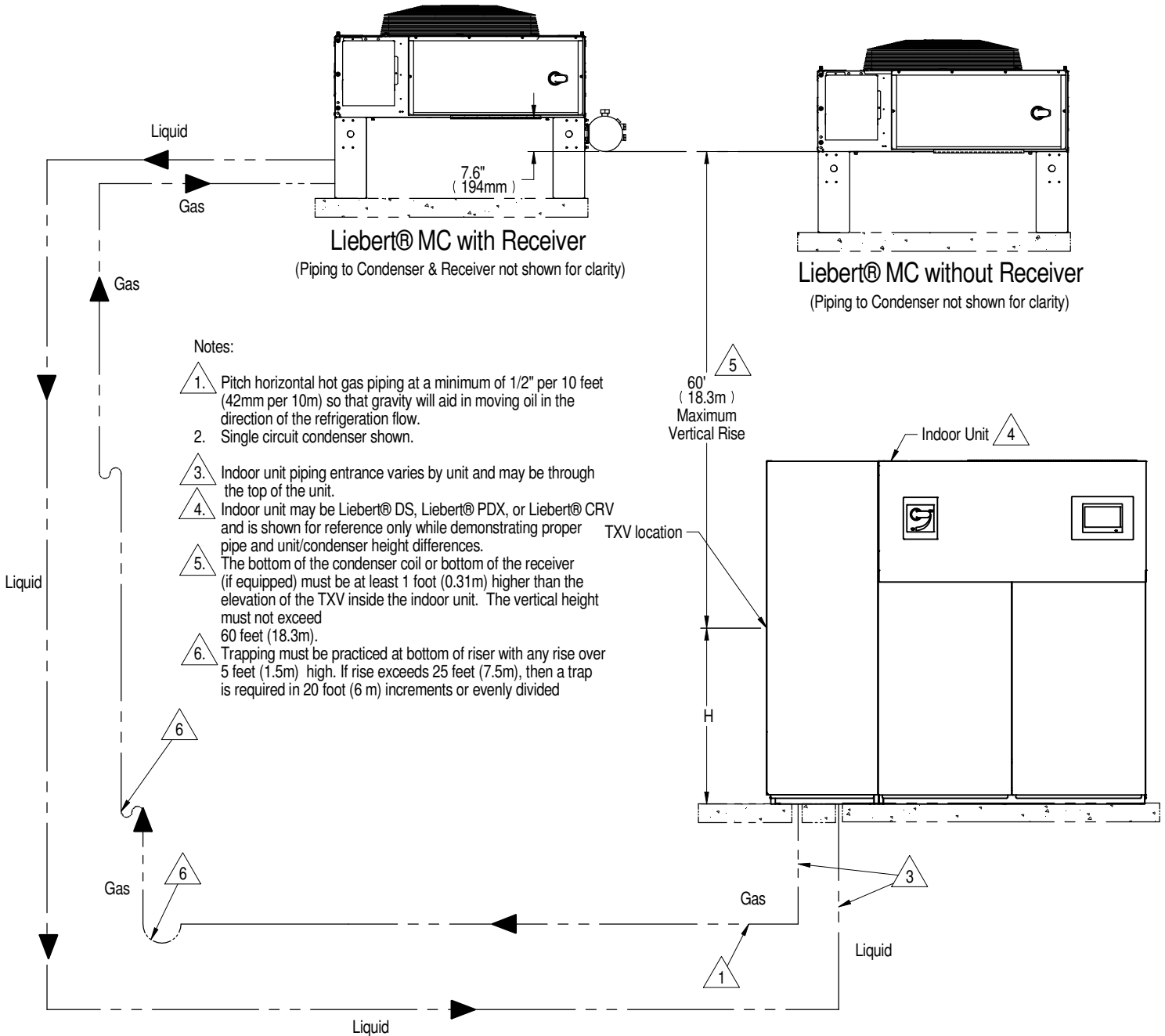

Internal TXV Height	H in. (mm)
Liebert® PDX Downflow	44 (1118)
Liebert® PDX Upflow	20 (508)
Liebert® DS	43 (1092)
Liebert® CRV - CR019	45 (1143)
Liebert® CRV - CR020/CR035	27 (686)

----- Field piping

AIR COOLED PIPING SCHEMATIC CONDENSER AND INDOOR UNIT AT SAME LEVEL

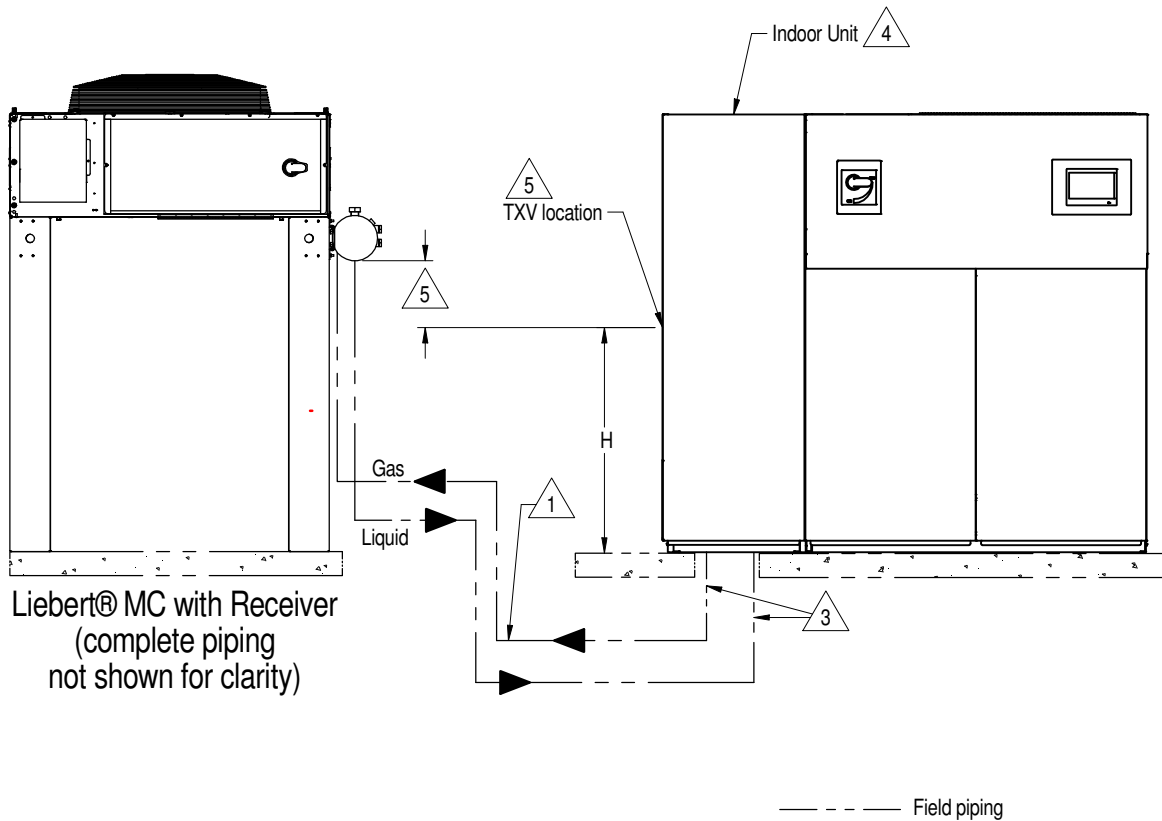

Liebert® MC with Receiver
(complete piping
not shown for clarity)

Notes:

1. Pitch horizontal hot gas piping at a minimum of 1/2" per 10 feet (42mm per 10m) so that gravity will aid in moving oil in the direction of the refrigeration flow.
2. Single circuit condenser shown.
3. Indoor unit piping entrance varies by unit and may be through the top of the unit.
4. Indoor unit may be Liebert® DS, Liebert® PDX, or Liebert® CRV and is shown for reference only.
5. The bottom of the receiver must be at least 1 foot (0.31m) higher than the elevation of the TXV inside the indoor unit, otherwise extended legs or a field piped subcooler needs to be utilized.

Internal TXV Height	H in. (mm)
Liebert® PDX Downflow	44 (1118)
Liebert® PDX Upflow	20 (508)
Liebert® DS	43 (1092)
Liebert® CRV - CR019	45 (1143)
Liebert® CRV - CR020/CR035	27 (686)

AIR COOLED PIPING SCHEMATIC CONDENSER AND INDOOR UNIT AT SAME LEVEL

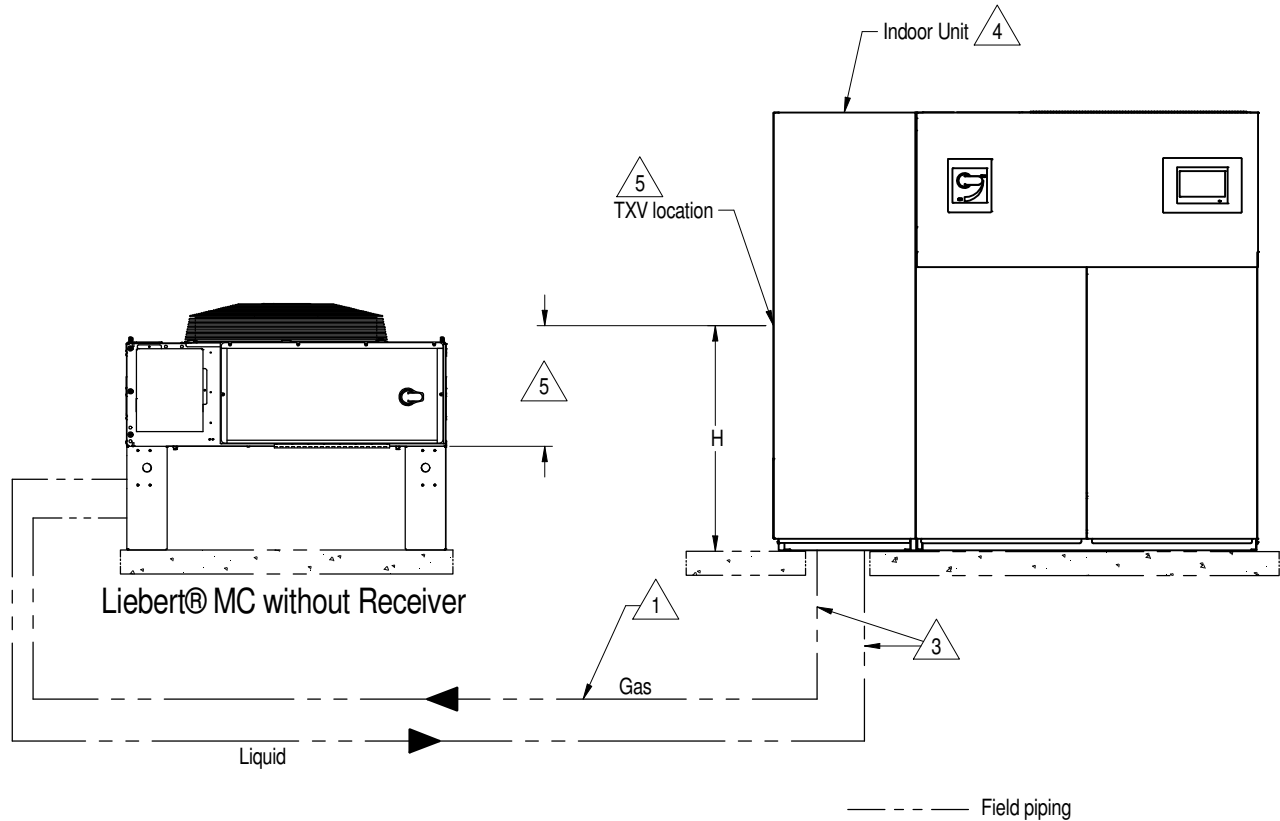

Notes:

1. Pitch horizontal hot gas piping at a minimum of 1/2" per 10 feet (42mm per 10m) so that gravity will aid in moving oil in the direction of the refrigeration flow.
2. Single circuit condenser shown.
3. Indoor unit piping entrance varies by unit and may be through the top of the unit.
4. Indoor unit may be Liebert® DS, Liebert® PDX, or Liebert® CRV and is shown for reference only.
5. The bottom of the coil must be less than 15' (4.6m) below the elevation of the TXV inside the indoor unit.

Internal TXV Height	H in. (mm)
Liebert® PDX Downflow	44 (1118)
Liebert® PDX Upflow	20 (508)
Liebert® DS	43 (1092)
Liebert® CRV - CR019	45 (1143)
Liebert® CRV - CR020/CR035	27 (686)

AIR COOLED PIPING SCHEMATIC CONDENSER BELOW INDOOR UNIT

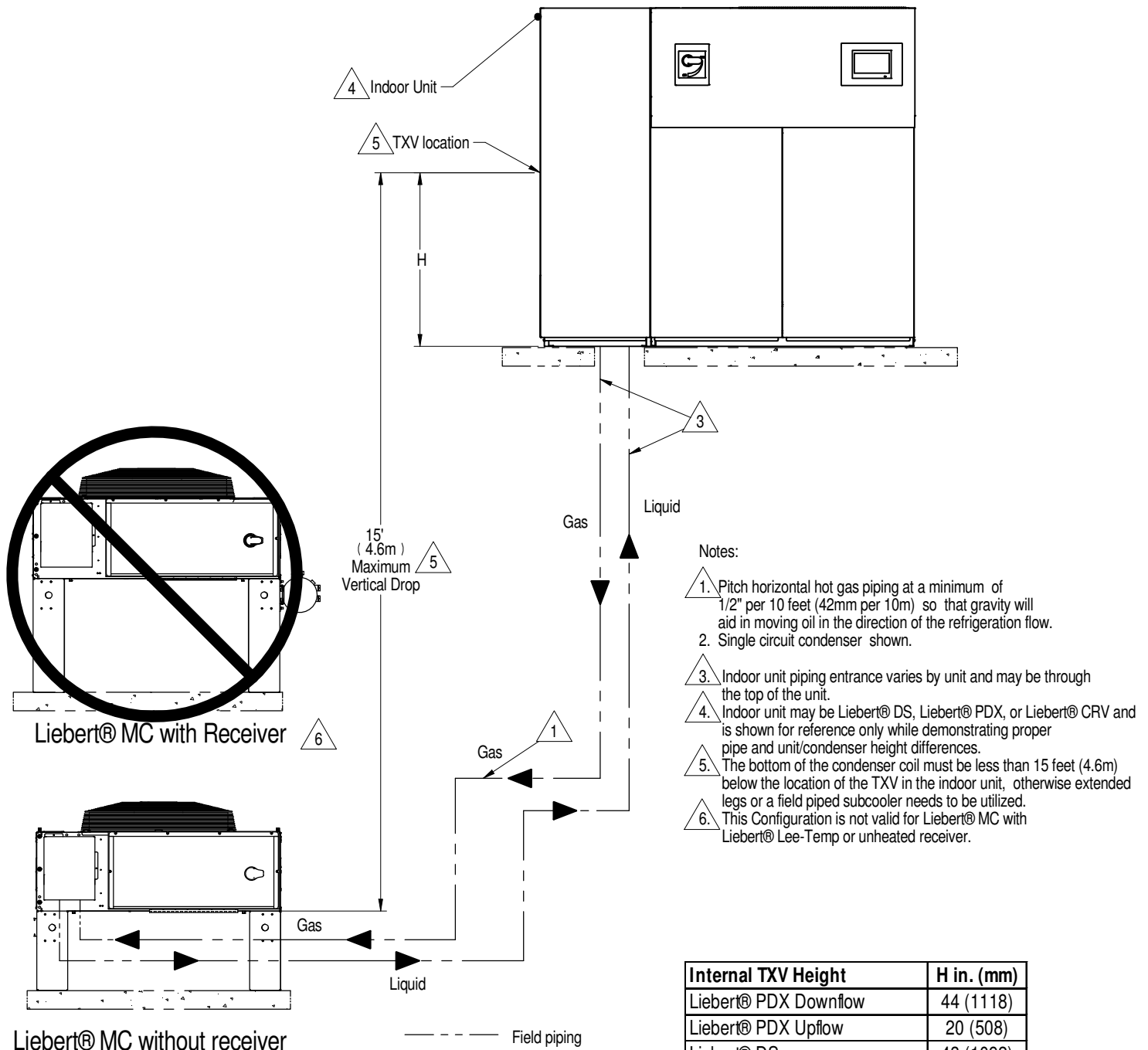

PRIMARY CONNECTION LOCATIONS CR020RA & CR035RA AIR COOLED MODELS

Notes:

- Piping and electrical connections available at the top and bottom of unit.
- Attention: Air cooled systems may require additional oil to be added in the field in order to allow for sufficient compressor lubrication. Please see the user manual for details.

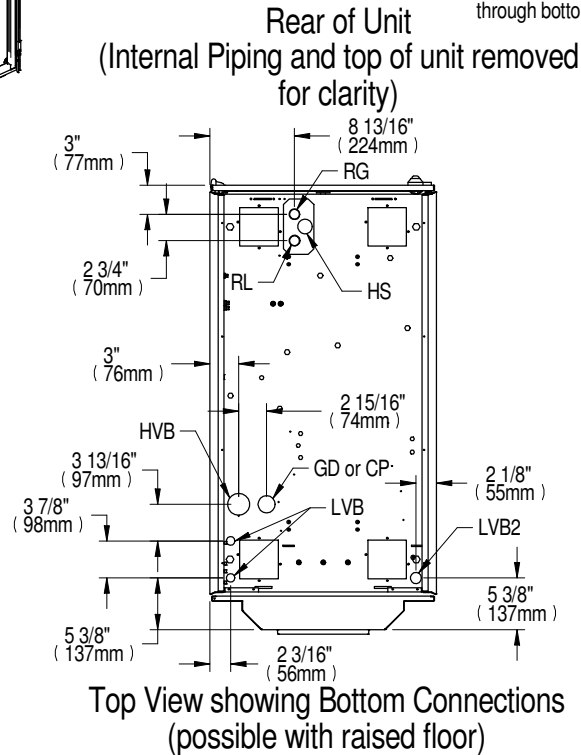
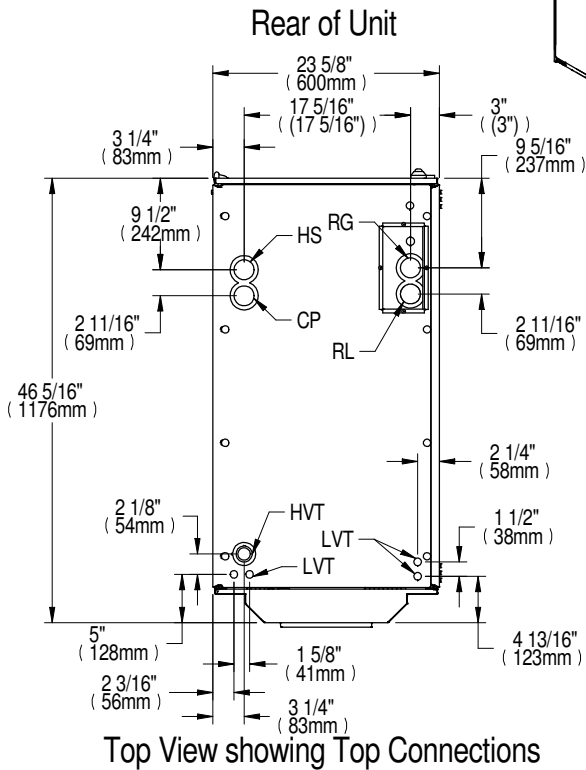
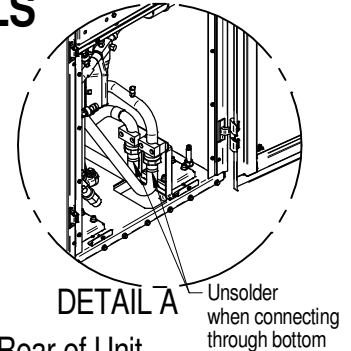
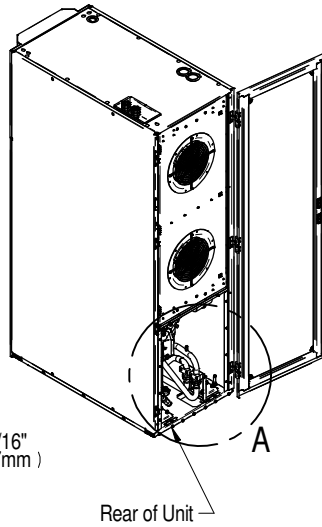

Unit Connections		CR20RA	CR35RA
RL	Refrigerant Liquid Line Inlet	1/2" O.D. Cu	5/8" O.D. Cu
RG	Refrigerant Gas Line Outlet	5/8" O.D. Cu	7/8" O.D. Cu
GD	Gravity Coil Pan Drain	1" MPT	
CP	Condensate Pump	1/2" NPT Female	
HS	Humidifier Supply	1/2" NPT Female (top connection) 1/4" Compression Fitting (bottom connection)	
HVT	High Voltage	Combination Knockout Hole Diameter 35mm (1-3/8"), 45mm (1-3/4") and 64mm (2-1/2")	
HVB	High Voltage Bottom Entrance (feed through bottom of unit)	Hole Diameter 64mm (2-1/2")	
LVT	Low Voltage	Hole Diameter 22mm (7/8") 2 places	
LVB	Low Voltage Bottom Entrance	Hole Diameter 28mm (1-1/8") 2 places	
LVB2	(feed through bottom of unit)	Hole Diameter 45mm (1-3/4") 1 place	

PRIMARY CONNECTION LOCATIONS 300mm (12in.) AIR COOLED MODELS

PIPING AND ELECTRICAL CONNECTIONS AVAILABLE AT THE TOP AND BOTTOM OF UNIT.

ATTENTION, AIR COOLED SYSTEMS MAY REQUIRE ADDITIONAL OIL TO BE ADDED IN THE FIELD IN ORDER TO ALLOW FOR SUFFICIENT COMPRESSOR LUBRICATION. SEE UNIT USER MANUAL FOR DETAILS.

Front of Unit
(Internal Piping and top of unit removed for clarity)

Front of Unit

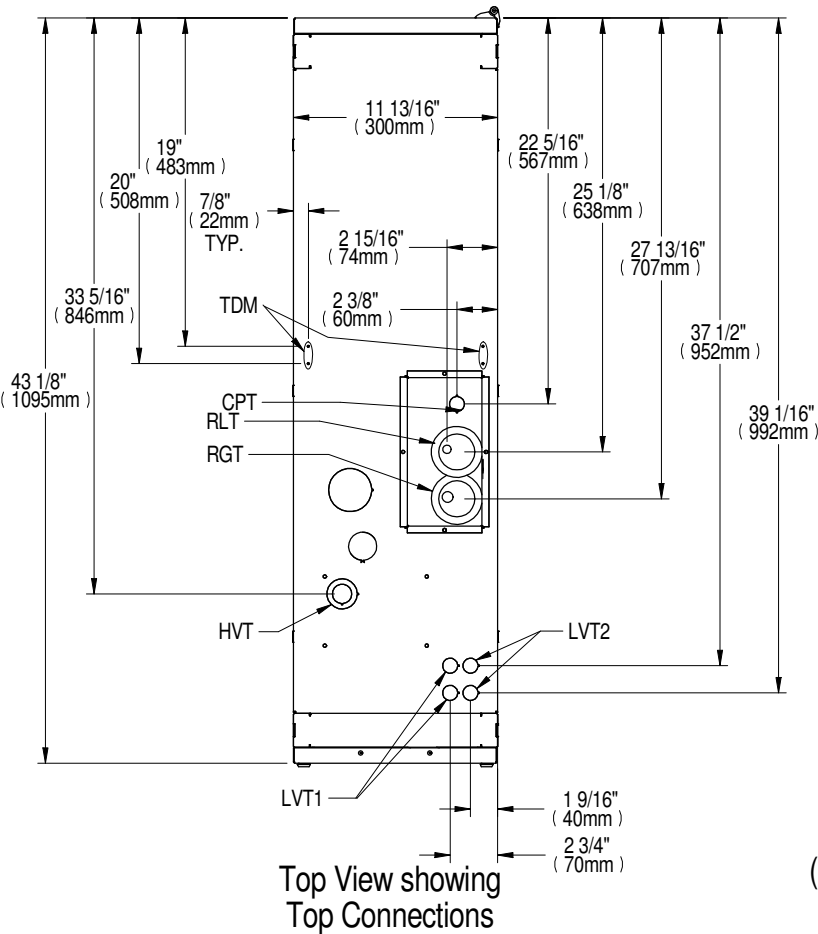

Top View showing Bottom Connections (possible with raised floor)

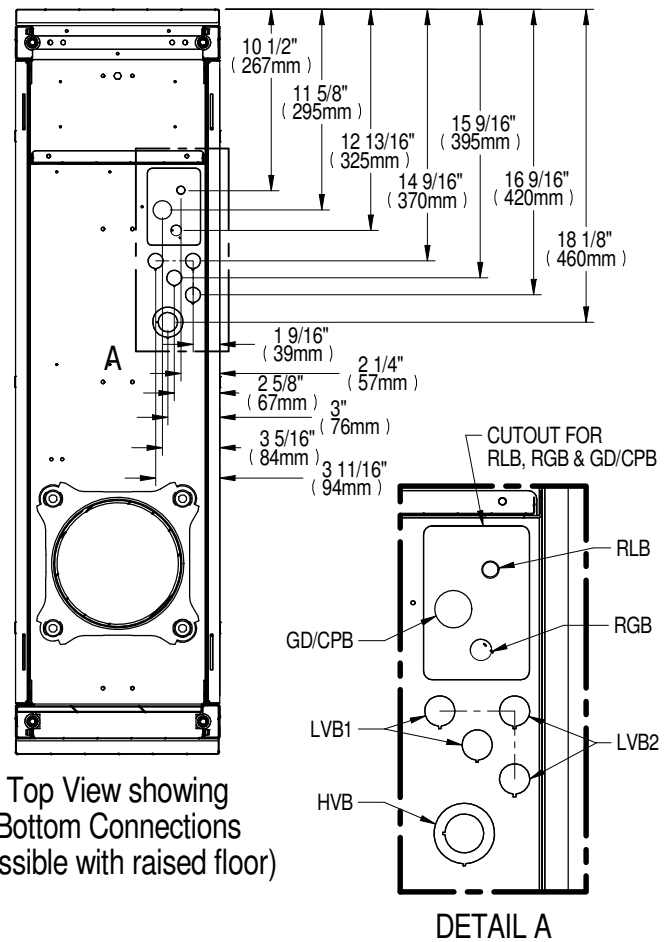

Unit Top Connections		CR019 (60Hz)	Unit Bottom Connections		CR019 (60Hz)
RLT	Refrigerant Liquid Line Inlet	1/2" O.D. Cu	RLB	Refrigerant Liquid Line Inlet	1/2" O.D. Cu
RGT	Refrigerant Gas Line Outlet	5/8" O.D. Cu	RGB	Refrigerant Gas Line Outlet	5/8" O.D. Cu
CPT	Condensate Pump	Knockout Hole Ø1-3/8" (35mm)	GD	Gravity Coil Pan Drain	Knockout Hole Diameter 1-3/4" (44mm)
HVT	High Voltage Top Connection	Combination Knockout Ø1-1/8" (29mm) & Ø1-3/4" (44mm)	CPB	Condensate Pump	
LVT1	Low Voltage (Twisted Pair)	Knockout Hole Ø7/8" (22mm) 2 places	HVB	High Voltage Bottom Entrance (feed through the base of the unit)	Combination Knockout 1-1/8" (29mm) & 1-3/4"
LVT2	Low Voltage (Shielded Cable)	Knockout Hole Ø7/8" (22mm) 2 places	LVB1	Low Voltage (Twisted Pair)	Knockout Hole Ø7/8" (22mm) 2 places
TDM	Tie Down (Top) Mounting	Hole Ø1/8" (3mm) 4 places	LVB2	Low Voltage (Shielded Cable)	

GENERAL ARRANGEMENT DIAGRAM 600mm WATER/GLYCOL COOLED MODELS

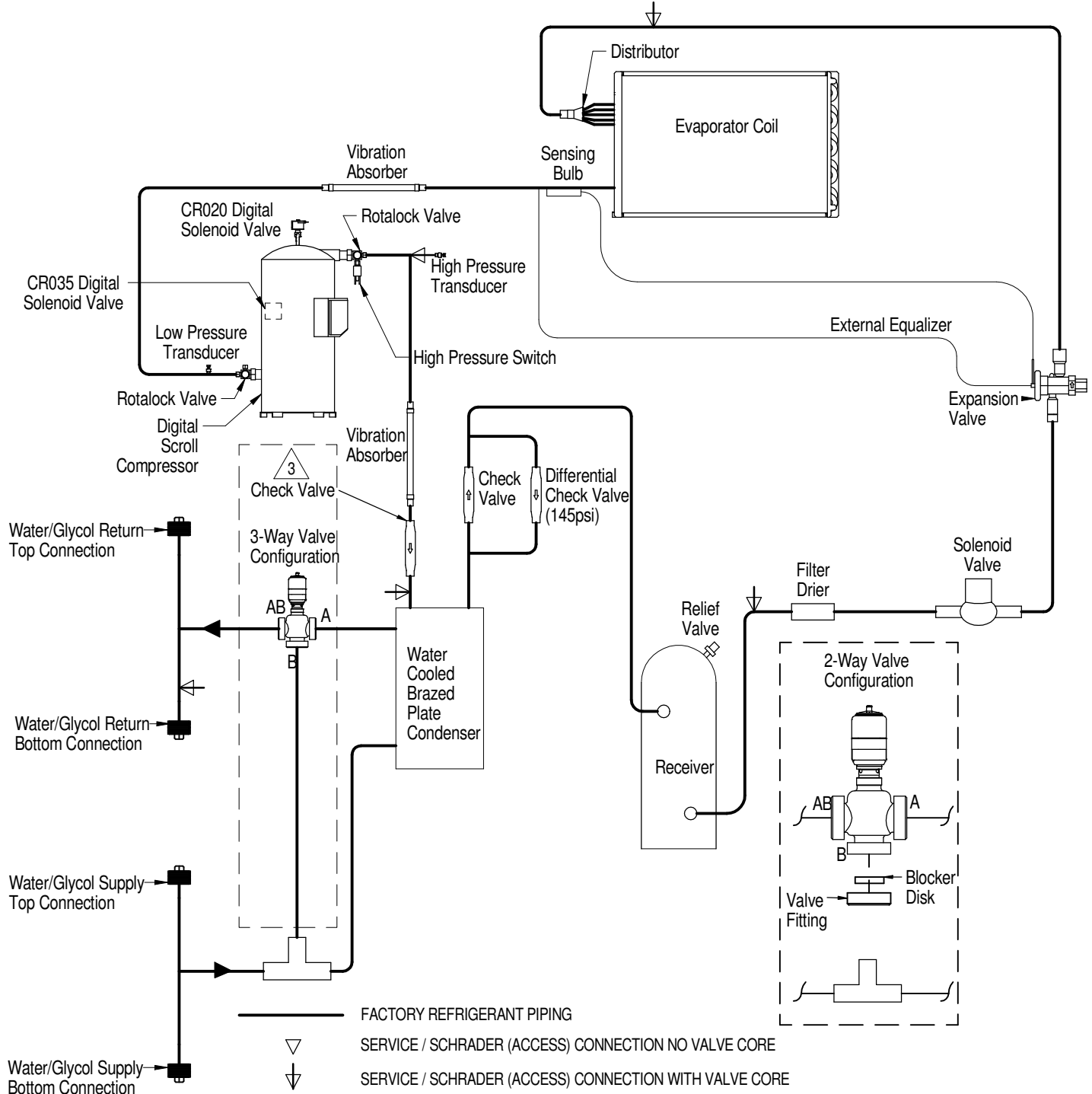

NOTES:

1. Schematic representation shown. Do not use for specific connection locations.
2. Install a 20 mesh strainer, in an easily accessible location, on the Water/Glycol Supply to prevent particles from entering the Heat Exchanger. Strainer Bypass Valves are recommended to allow the strainer to be cleaned while maintaining flow to the cooling unit.
3. Check Valve supplied only on CR020RW units.



GENERAL ARRANGEMENT DIAGRAM 300mm (12in.) WATER/GLYCOL COOLED MODELS

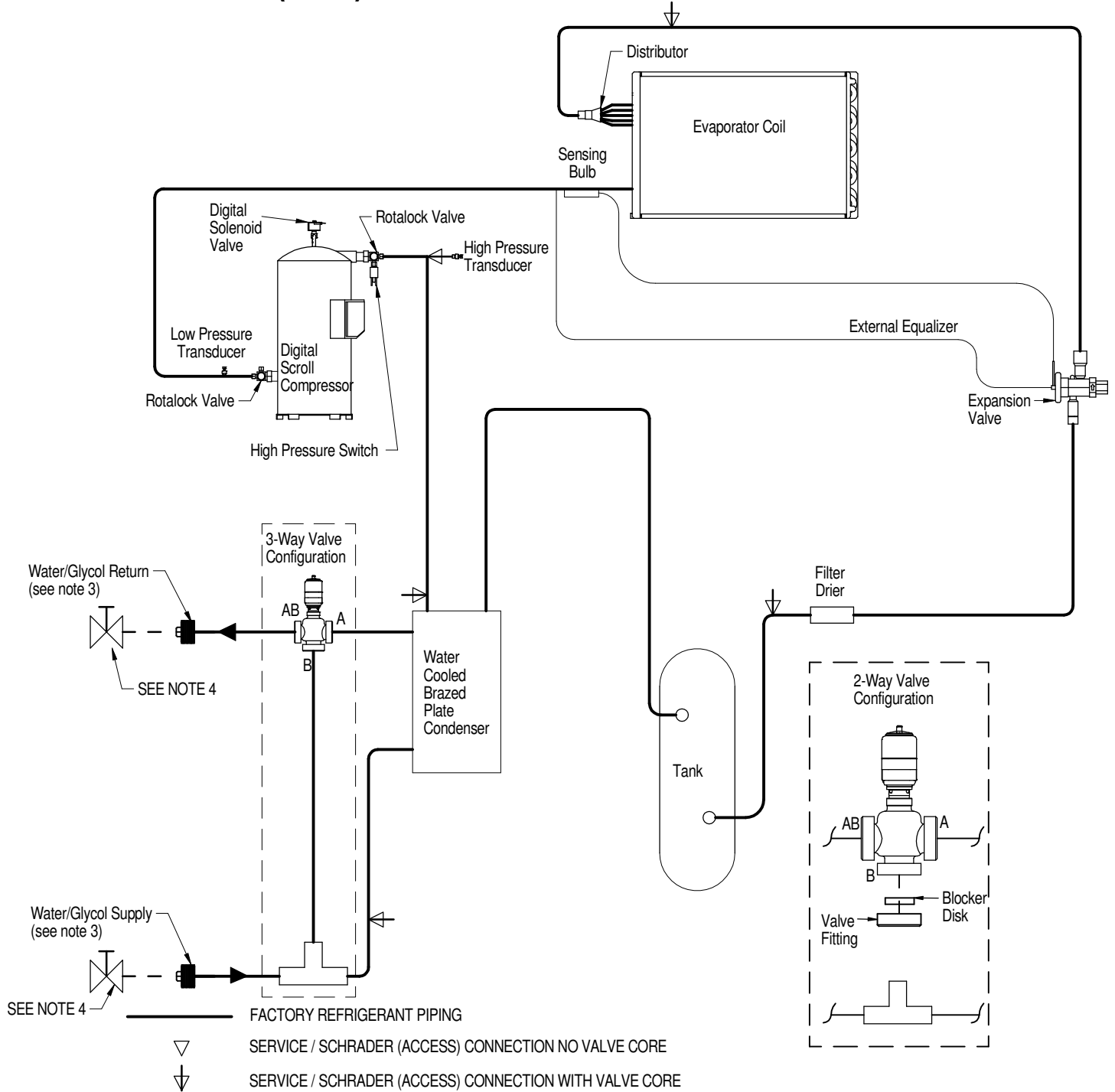

PRIMARY CONNECTION LOCATIONS
CR020RW & CR035RW WATER/GLYCOL MODELS Rear View
 (components removed for clarity)

Notes:

1. Piping and Electrical connections available at the top & bottom of unit.
2. Install a 35 mesh strainer, in an easily accessible location, on the Water/Glycol Supply to prevent particles from entering the heat exchanger. Strainer bypass valves are recommended to allow the strainer to be cleaned while maintaining flow to the cooling unit.

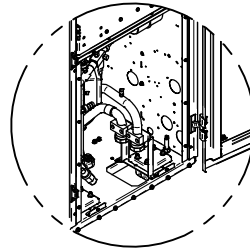
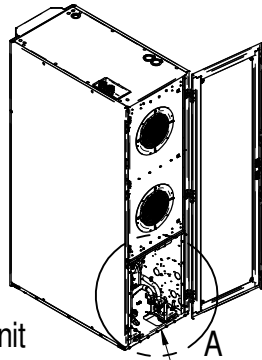

(components removed for clarity)

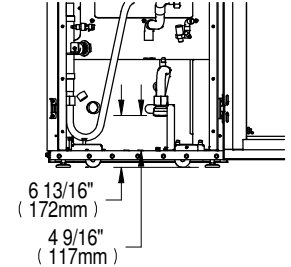

Rear of Unit

DETAIL A

Rear of Unit

(Internal Piping and top of unit removed for clarity)

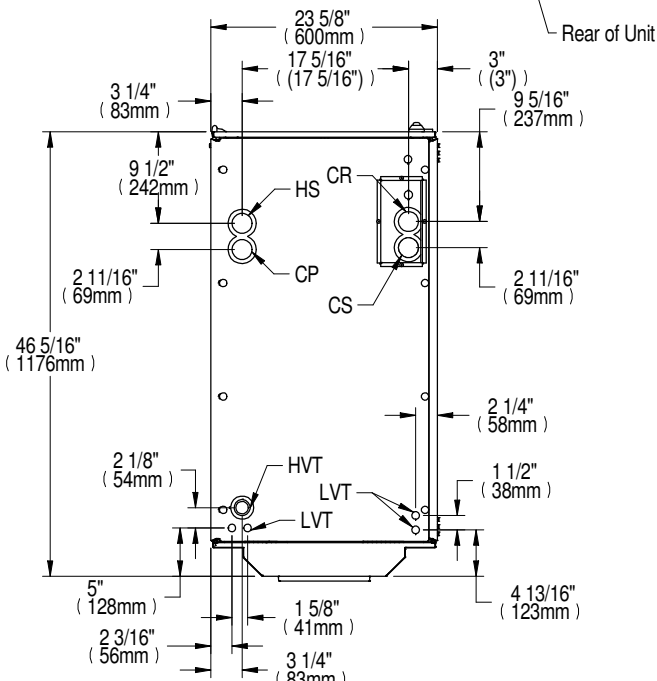

Top View showing Top Connections

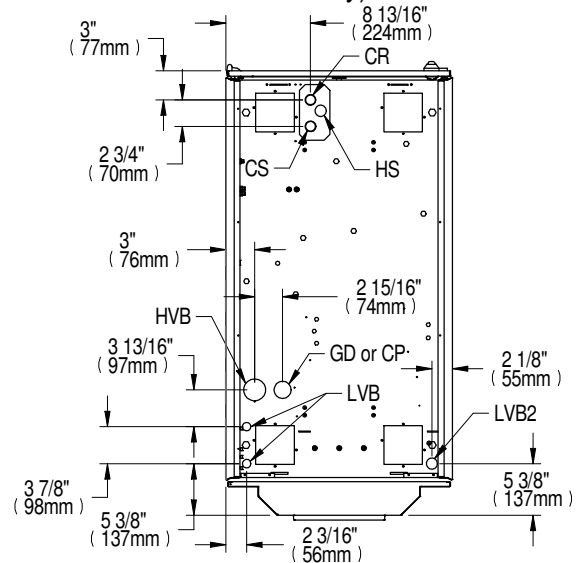

Top View showing Bottom Connections
 (possible with raised floor)

Unit Connections		CR020RW	CR035RW
CS	Water/Glycol Coolant Supply	1-1/4 NPT Female	
CR	Water/ Glycol Coolant Return		
GD	Gravity/Coil Pan Drain	1" NPT Male	
HS	Humidifier Supply	1/2" NPT Female (top connection) 1/4" Compression Fitting (bottom connection)	
CP	Condensate Pump	1/2" NPT Female	
HVT	High Voltage Top Connection	Combination Knockout Hole Diameter 35mm (1-3/8"), 45mm (1-3/4" and 64mm (2-1/2"))	
HVB	High Voltage Bottom Connection (feed through base of unit)	Knockout Hole Diameter 64mm (2-1/2")	
LVT	Low Voltage Top Connection	Knockout Hole Diameter 22mm (7/8") 4 places	
LVB	Low Voltage Bottom Entrance	Knockout Hole Diameter 28mm (1-1/8") 2 places	
LVB2	(feed through base of unit)	Knockout Hole Diameter 45mm (1-3/4") 1 place	

PRIMARY CONNECTION LOCATIONS 300mm (12in.) WATER/GLYCOL COOLED MODELS

PIPING CONNECTION LOCATIONS MUST BE ORDERED TOP OR BOTTOM.
ELECTRICAL CONNECTIONS AVAILABLE TOP OR BOTTOM OF UNIT.

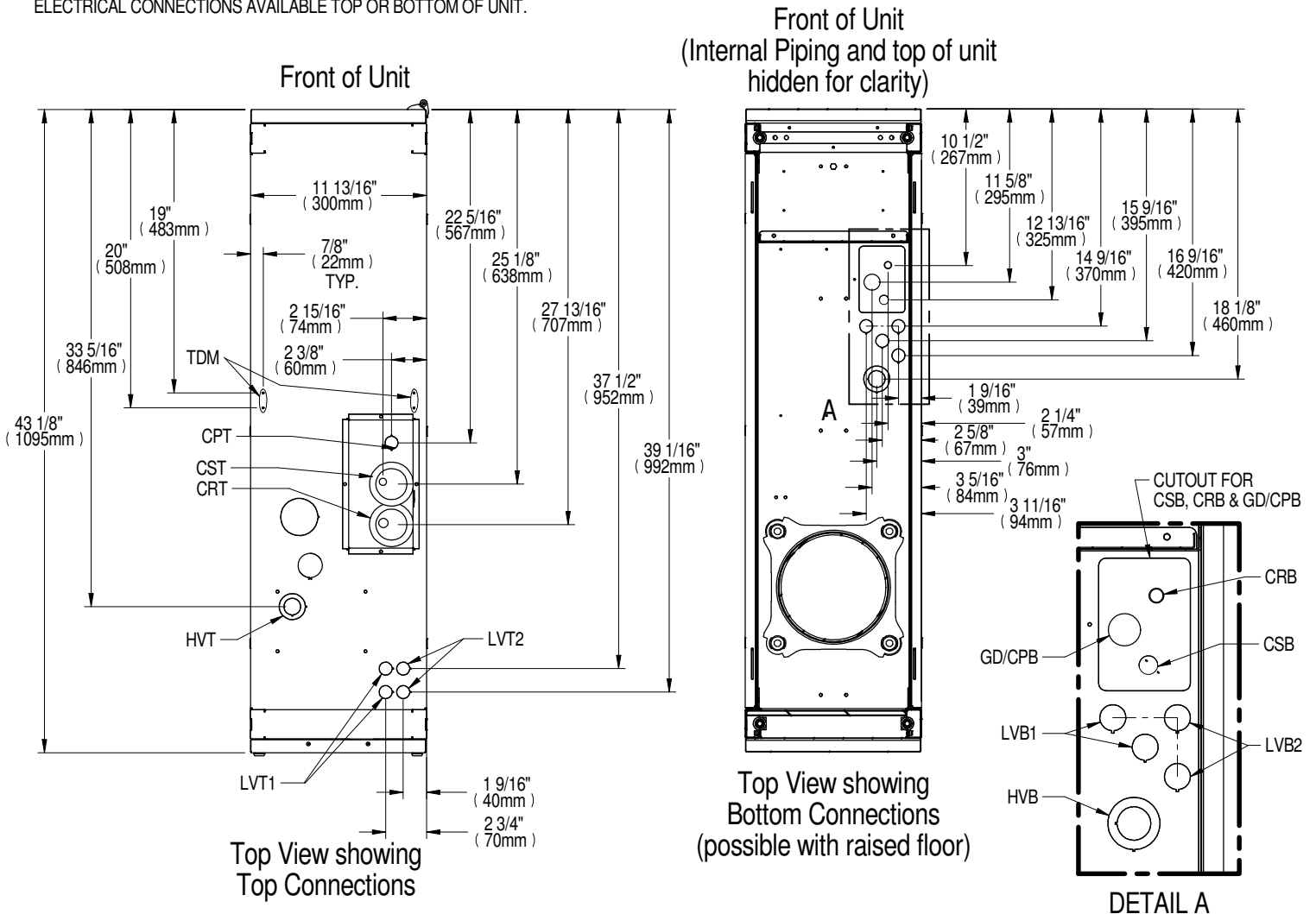

Unit Top Connections		CR019 (60Hz)	Unit Bottom Connections		CR019 (60 Hz)
CST	Water/Glycol Coolant Supply	1-1/4" NPT Female	CSB	Water/Glycol Coolant Supply	1-1/4" NPT Female
CRT	Water/Glycol Coolant Return		CRB	Water/Glycol Coolant Return	
CPT	Condensate Pump	Knockout Hole Ø1-3/8" (35mm)	GD	Gravity Coil Pan Drain	Knockout Hole Ø1-3/4" (44mm)
HVT	High Voltage	Combination Knockout Ø1-1/8" (29mm) & Ø1-3/4" (44mm)	CPB	Condensate Pump	
LVT1	Low Voltage (Twisted Pair)	Knockout Hole Ø7/8" (22mm) 2 plcs.	HVB	High Voltage Bottom Entrance (feed through the bottom of unit)	Combination Knockout Ø1-1/8" (29mm) & Ø1-3/4" (44mm)
LVT2	Low Voltage (Shielded Cable)		LVB1	Low Voltage (Twisted Pair)	Knockout Hole Ø7/8" (22mm) 2 plcs.
TDM	Tie Down (Top) Mounting	Hole Ø1/8" (3mm) 4 plcs.	LVB2	Low Voltage (Shielded Cable)	

GENERAL ARRANGEMENT DIAGRAM 600mm (24in.) CHILLED WATER MODELS

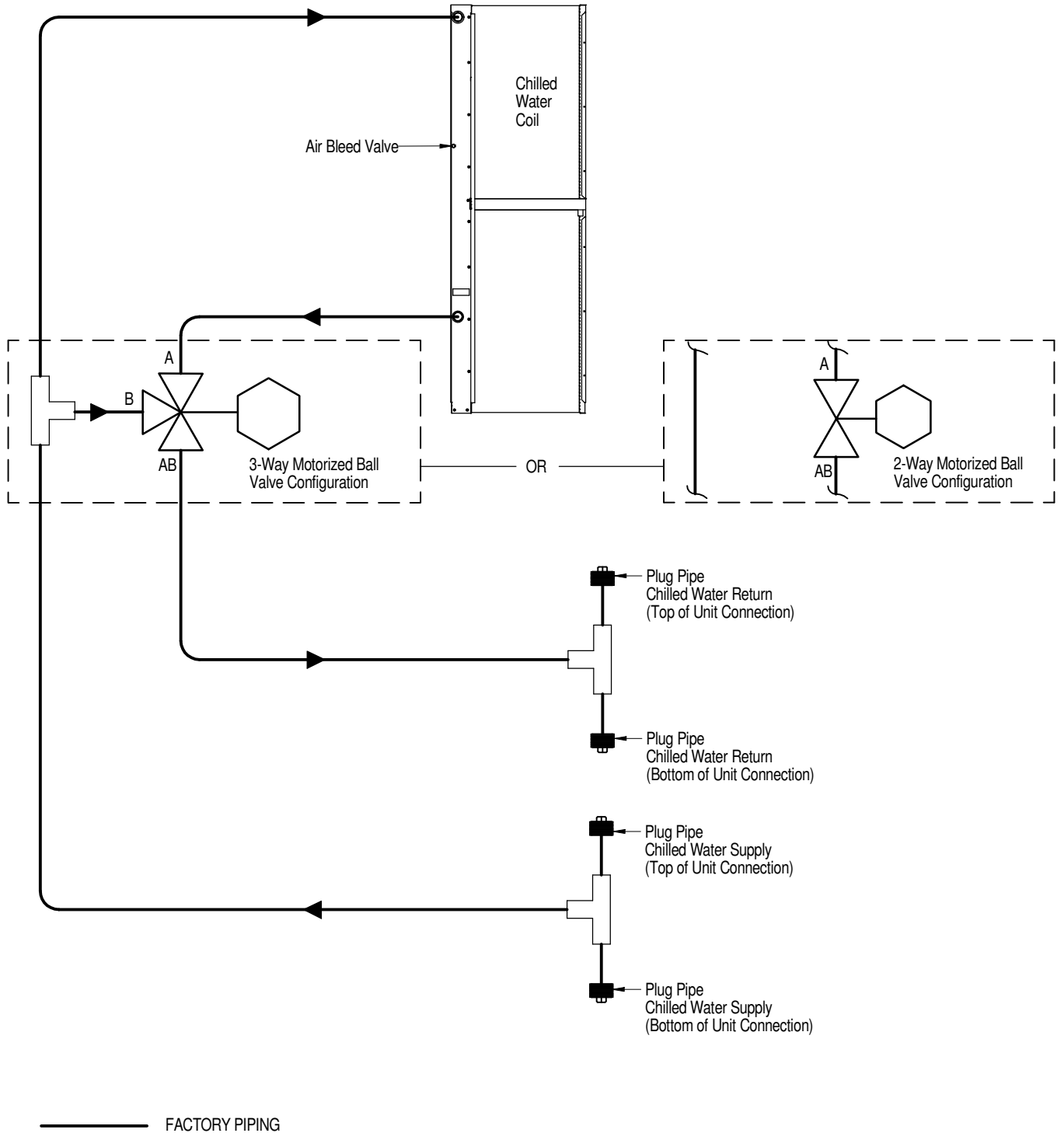

NOTE: SCHEMATIC REPRESENTATION SHOWN. DO NOT USE FOR SPECIFIC CONNECTION LOCATIONS.

GENERAL ARRANGEMENT DIAGRAM 300mm (12in.) CHILLED WATER MODELS

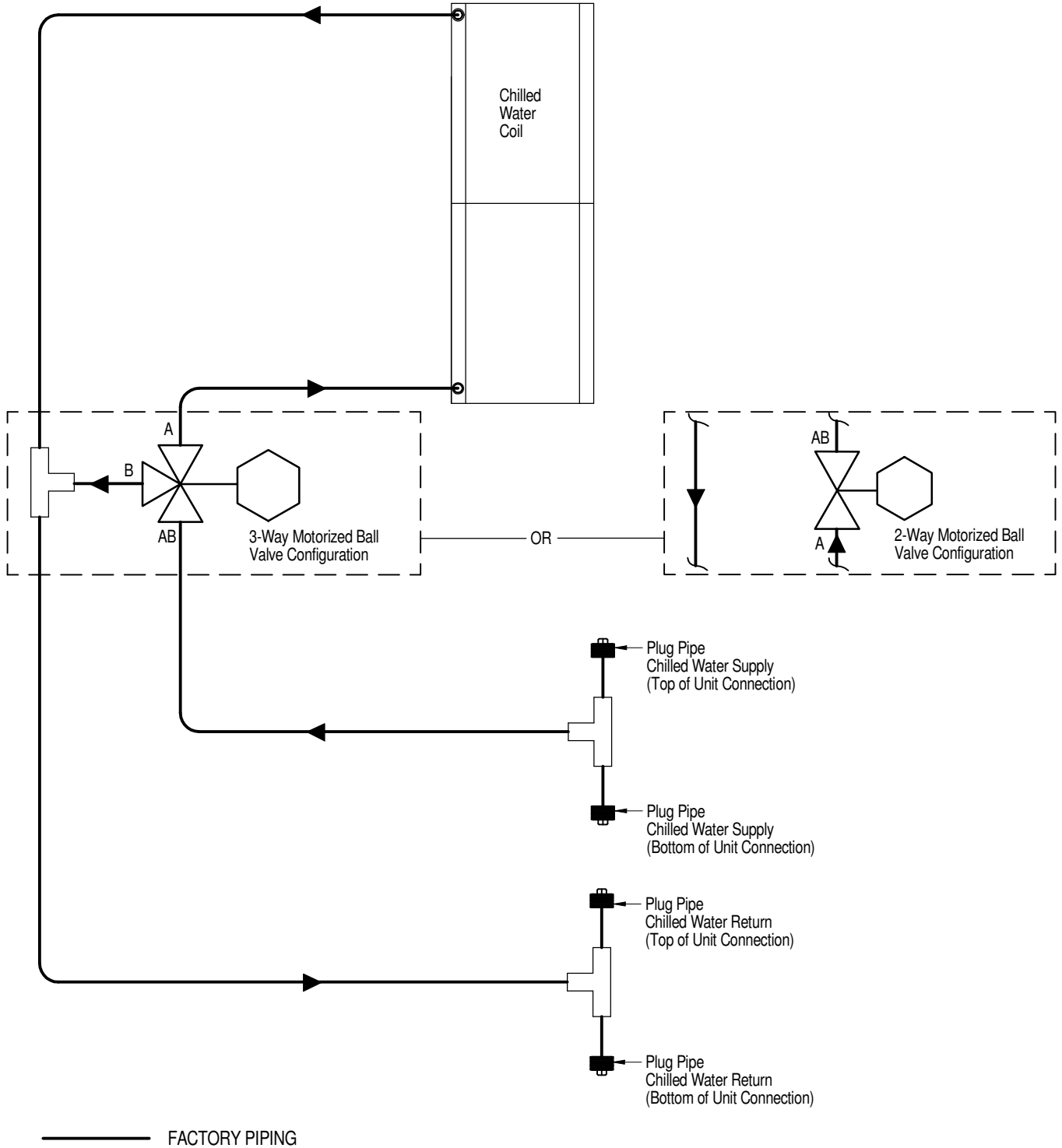

NOTE: SCHEMATIC REPRESENTATION SHOWN. DO NOT USE FOR SPECIFIC CONNECTION LOCATIONS.

PRIMARY CONNECTION LOCATIONS CR032RC & CR040RC CHILLED WATER MODELS

Notes:
1. Piping and Electrical connections available at the top & bottom of unit.

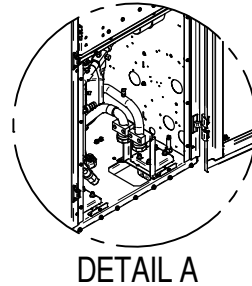
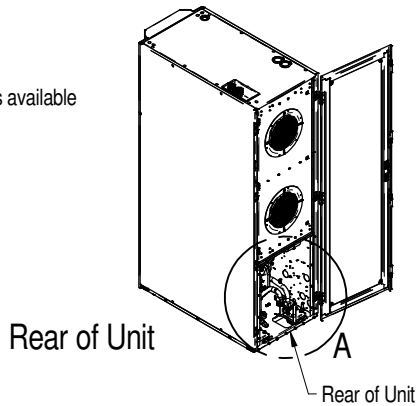

Rear View
(components removed for clarity)

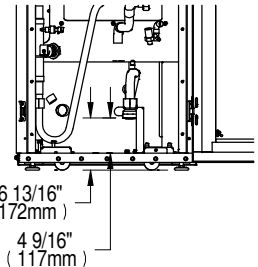

Rear of Unit
(Internal Piping and top of unit removed for clarity)

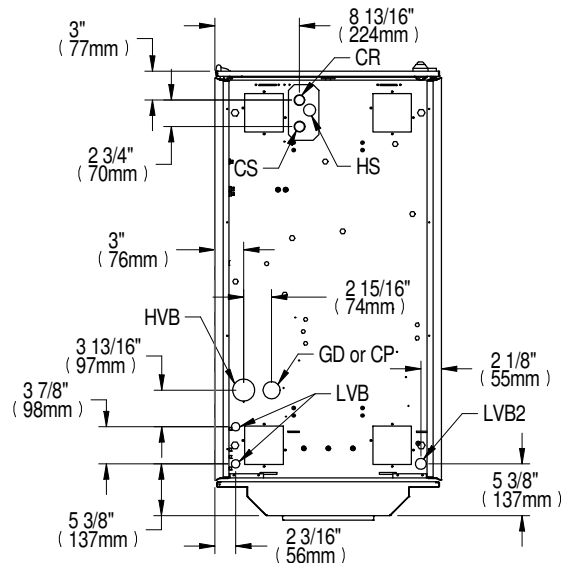

Top View showing Bottom Connections
(possible with raised floor)

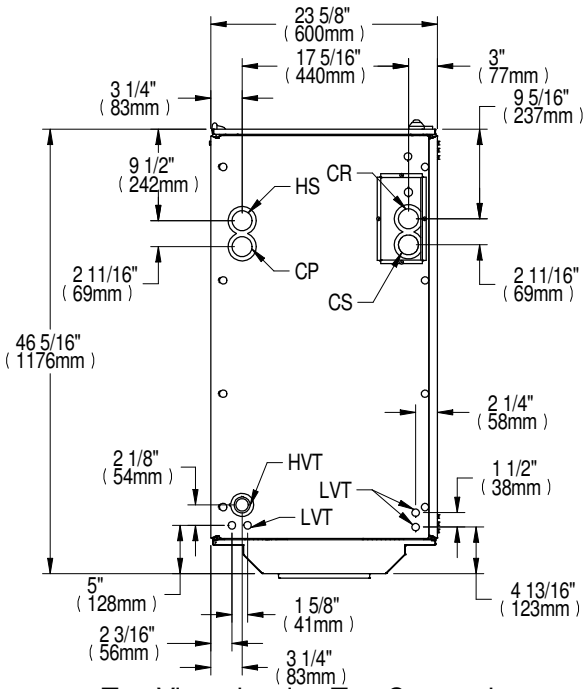

Top View showing Top Connections

Unit Connections		CR32RC	CR40RC
CS	Chilled Water Supply	1-1/4 NPT Female	
CR	Chilled Water Return		
GD	Gravity/Coil Pan Drain	1" MPT	
HS	Humidifier Supply	1/2" NPT Female (top connection) 1/4" Compression Fitting (bottom connection)	
CP	Condensate Pump	1/2" NPT Female	
HVT	High Voltage Top Connection	Combination Knockout Hole Diameter 35mm (1-3/8"), 45mm (1-3/4" and 64mm (2-1/2"))	
HVB	High Voltage Bottom Connection (feed through base of unit)	Knockout Hole Diameter 64mm (2-1/2")	
LVT	Low Voltage Top Connection	Knockout Hole Diameter 22mm (7/8") 4 places	
LVB	Low Voltage Bottom Entrance (feed through base of unit)	Knockout Hole Diameter 28mm (1-1/8") 2 places	
LVB2		Knockout Hole Diameter 45mm (1-3/4") 1 place	

PRIMARY CONNECTION LOCATIONS CR050RC CHILLED WATER MODEL

Notes:
1. Piping and Electrical connections available at the top & bottom of unit.

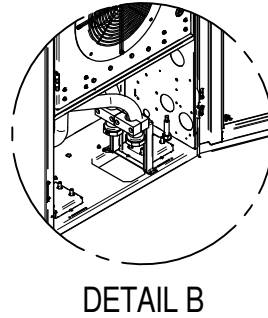
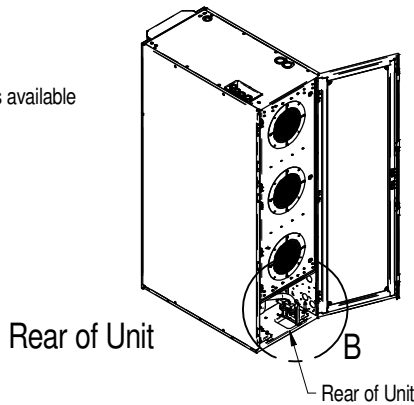

Rear View
(components removed for clarity)

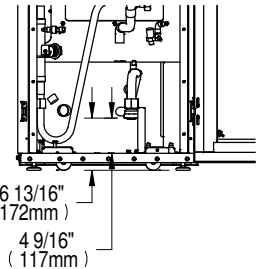

Rear of Unit
(Internal Piping and top of unit removed for clarity)

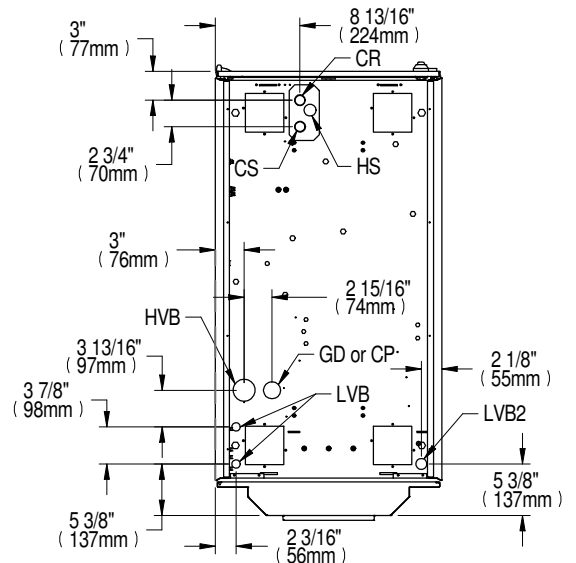

Top View showing Bottom Connections
(possible with raised floor)

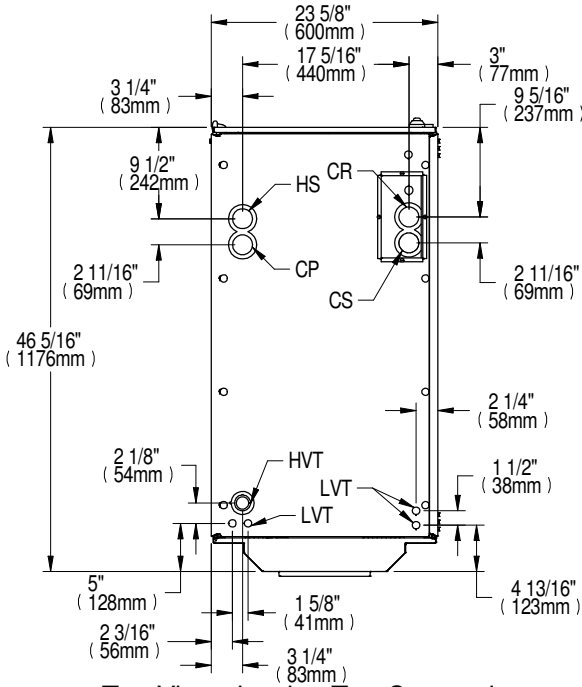

Top View showing Top Connections

Unit Connections		CR050RC
CS	Chilled Water Supply	1-1/4 NPT Female
CR	Chilled Water Return	
GD	Gravity/Coil Pan Drain	1" MPT
HS	Humidifier Supply	1/2" NPT Female (top connection) 1/4" Compression Fitting (bottom connection)
CP	Condensate Pump	1/2" NPT Female
HVT	High Voltage Top Connection	Combination Knockout Hole Diameter 35mm (1-3/8"), 45mm (1-3/4" and 64mm (2-
HVB	High Voltage Bottom Connection (feed through base)	Knockout Hole Diameter 64mm (2-1/2")
LVT	Low Voltage Top Connection	Knockout Hole Diameter 22mm (7/8") 4 places
LVB	Low Voltage Bottom Entrance	Knockout Hole Diameter 28mm (1-1/8") 2 places
LVB2	(feed through base of unit)	Knockout Hole Diameter 45mm (1-3/4") 1 place

LIEBERT® INTELLISLOT CABLE CONNECTION PATHS LIEBERT® INTELLISLOT WIRE ROUTING TOP OF UNIT 300mm (12in.) ALL MODELS

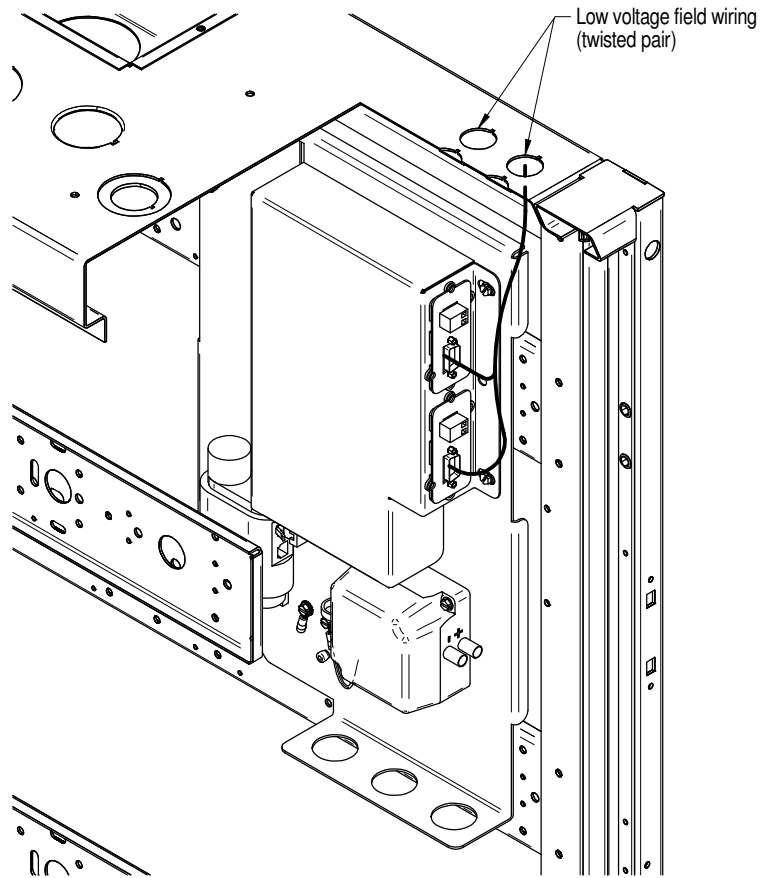
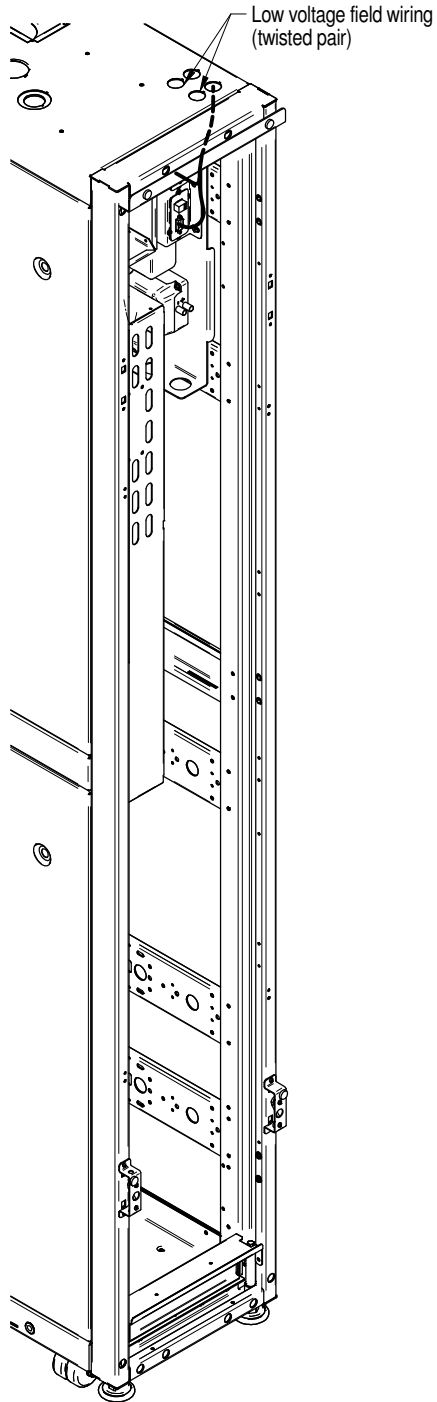

**LIEBERT® INTELLISLOT CABLE CONNECTION PATHS
LIEBERT® INTELLISLOT WIRE ROUTING BOTTOM OF UNIT
300mm (12in.) AIR, WATER/GLYCOL COOLED MODELS**

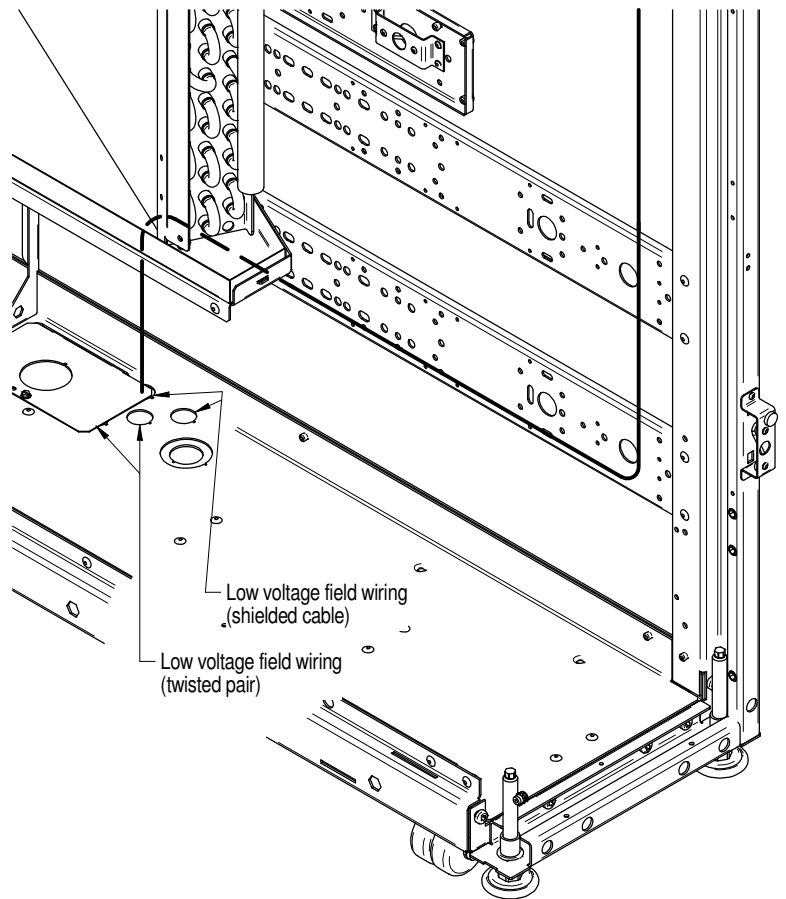
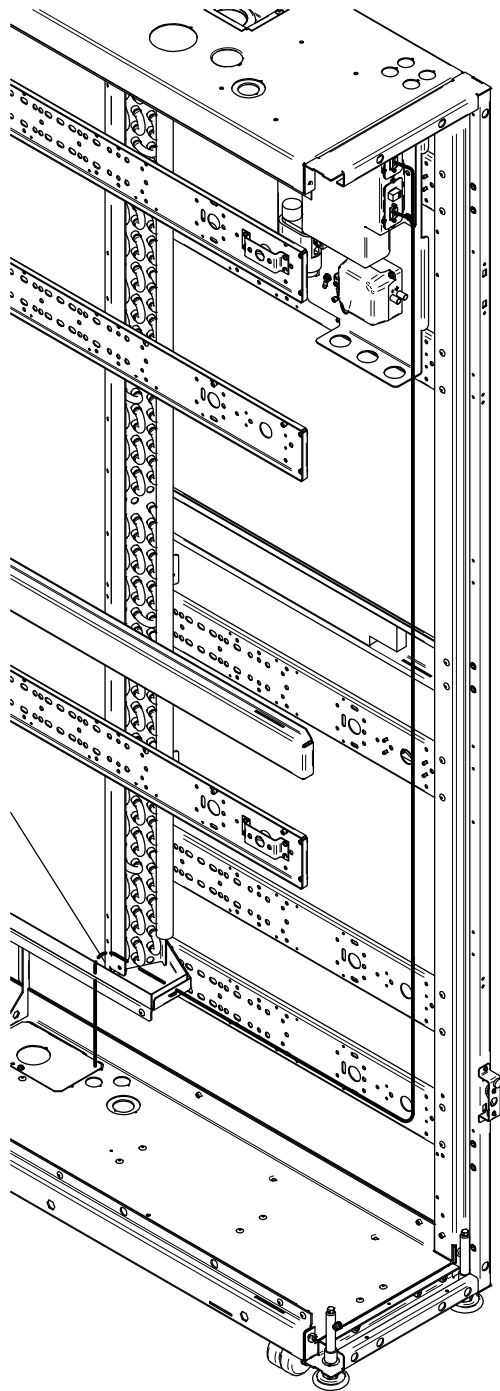

Secure tie the field wiring shielded cable to the rail. Route the shielded cable up toward the Intellislots and fasten to the side rails as needed.

LIEBERT® INTELLISLOT CABLE CONNECTION PATHS LIEBERT® INTELLISLOT WIRE ROUTING BOTTOM OF UNIT 300mm (12in.) CHILLED WATER MODELS

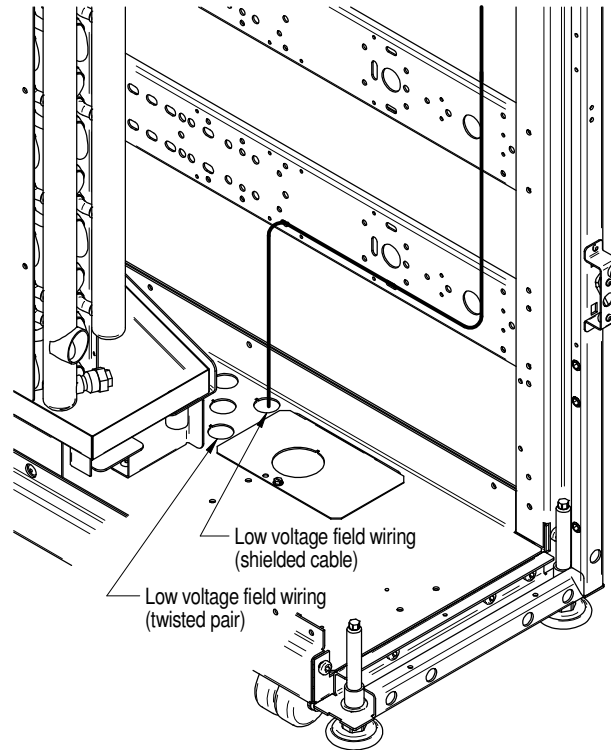
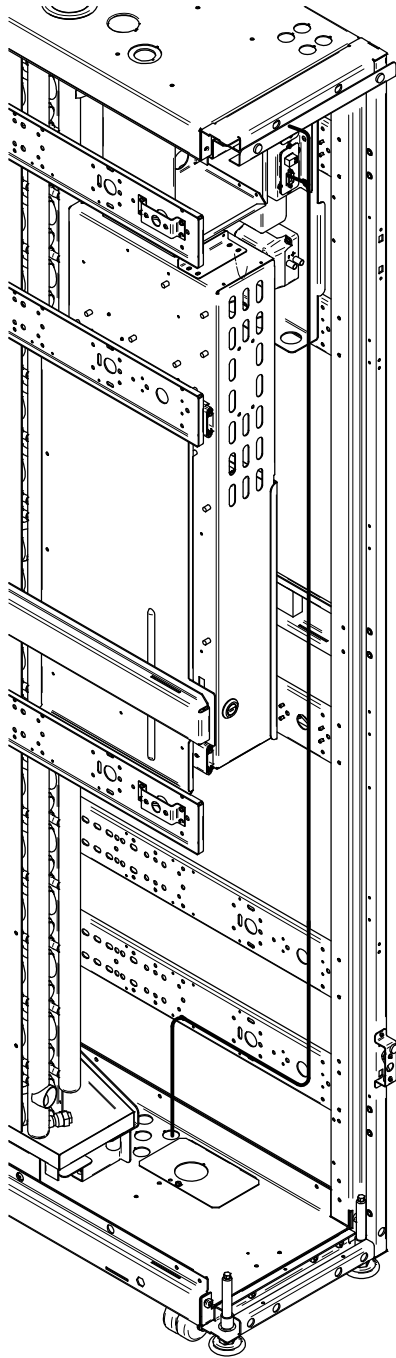

Secure the shielded cable to the rail.
Route the shielded cable up toward
the Intellislots and fasten to the side
rails as needed.

PRIMARY CONNECTION LOCATIONS 300mm (12in.) CHILLED WATER MODELS

PIPING AND ELECTRICAL CONNECTIONS AVAILABLE AT THE TOP AND BOTTOM OF UNIT.

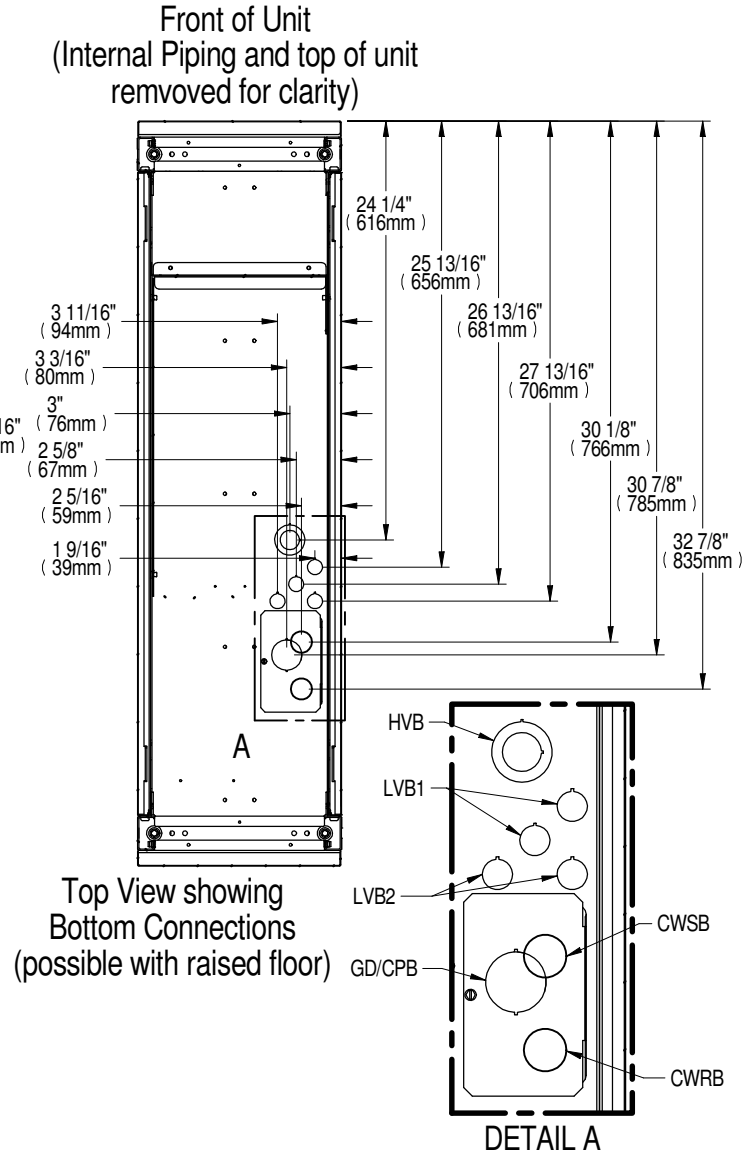
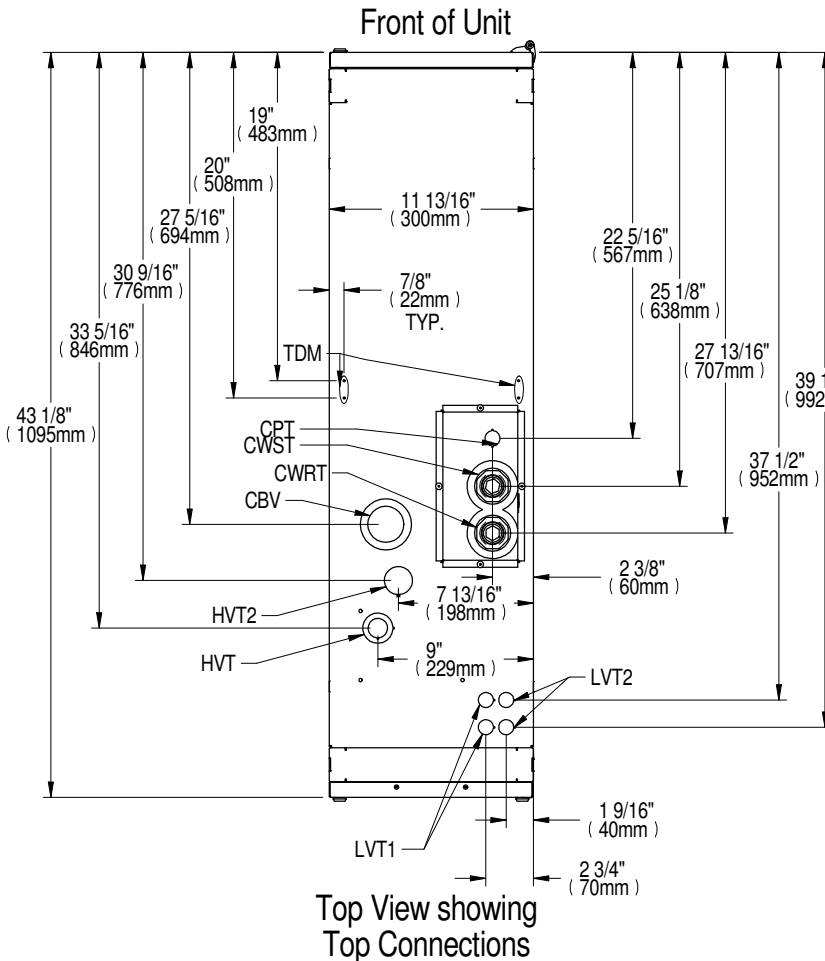

Unit Top Connections		CR032RC (60Hz)	Unit Bottom Connections		CR032RC (60Hz)
CWST	Chilled Water Supply	1-1/4" NPT Female	CWSB	Chilled Water Supply	1-1/4" NPT Female
CWRT	Chilled Water Return		CWRB	Chilled Water Return	
CPT	Condensate Pump	Knockout Ø1-3/8" (35mm)	GD	Gravity Coil Pan Drain	Knockout Ø1-3/4" (44mm)
CBV	Coil Bleeder (Schrader Valve Access)	Rubber Plug Ø2" (51mm)	CPB	Condensate Pump	
HVT	High Voltage	Combination Knockout Ø1-1/8" (29mm) & 1-3/4"	HVB	High Voltage Bottom Entrance (feed through bottom of unit)	Combination Knockout Ø1-1/8" (29mm) & Ø1-3/4"
HVT2	High Voltage (120V Units)	Knockout Ø1-3/4" (44mm)	LVB1	Low Voltage (Twisted Pair)	Knockout Ø7/8" (22mm) 2 plcs.
LVT1	Low Voltage (Twisted Pair)	Knockout Ø7/8" (22mm) 2 plcs.	LVB2	Low Voltage (Shielded Cable)	
LVT2	Low Voltage (Shielded Cable)				
TDM	Tie Down (Top) Mounting	Hole Ø1/8" (3mm)			



LIEBERT® CRV

ELECTRICAL FIELD CONNECTIONS DESCRIPTIONS 600mm (24in.) MODELS

STANDARD ELECTRICAL CONNECTIONS

- 1) **High voltage connection through the bottom of the electric panel** – 1-3/8" (34.9mm), 1-3/4" (44.5mm) & 2-1/2" (64mm) diameter concentric knockout.
- 2) **Low voltage connection through the bottom of the electric panel** - Quantity (2) 7/8" (22mm) diameter knockouts.
- 3) **High voltage connection through the top of the unit** – 1-3/8" (34.9mm), 1-3/4" (44.5mm) & 2-1/2" (64mm) diameter concentric knockout.
- 4) **Low voltage connection through the top of the unit** - Quantity (4) 7/8" (22mm) diameter knockouts.
- 5) **Three phase electrical service** – Connect to terminals on disconnect switch. Three phase service not by Liebert®. (see page 2 for an important note regarding unit electrical service)
- 6) **Factory Installed locking Disconnect Switch** - There are 2 different versions of Disconnect Switch frame, one applies for non-fuse disconnect and one for fused disconnect switch. Please refer to manual for information.
- 7) **Earth ground** - Terminal for field supplied earth grounding wire.
- 8) **Remote unit shutdown** - Replace existing jumper between terminals 37 & 38 with field supplied normally closed switch having a minimum 75VA, 24VAC rating. Use field supplied Class 1 wiring.
- 9) **Customer alarm inputs** - Terminals for field supplied, normally closed contacts, having a minimum 75VA, 24VAC rating, between terminals 3 & 50, 2 & 51, 5 & 55, or 3 & 56. Use field supplied Class 1 wiring. Terminal 3 & 56 are used for humidifier alarm when a humidifier is installed. The remaining terminals are available for customer alarm inputs, such as; smoke sensors and building fire alarms.
- 10) **Common alarm** - On any alarm, normally open dry contact is closed across terminals 75 & 76 for remote indication. 1 AMP, 24VAC max load. Use Class 1 field supplied wiring.
- 11) **Heat rejection interlock** - On any call for compressor operation, normally open dry contact is closed across terminals 70 & 71 to heat rejection equipment. 1 AMP, 24VAC max load. Use Class 1 field supplied wiring.

STANDARD ELECTRICAL CONNECTIONS

- 12) **CANbus Connector** – Terminal block with terminals 49-1 (CAN-H) and 49-3 (CAN-L) + SH (shield connection). The terminals are used to connect the CANbus communication cable (provided by others) from the indoor unit to the Liebert® MC.
- 13) **CANbus Cable** – CANbus cable provided by others to connect to the outdoor condenser. No special considerations are required when the total external cable connection between the indoor unit and outdoor unit(s) is less than 450FT (137M). For total external cable connections greater than 450FT (137M) but less than 800FT (243M) a CANbus isolator is required. Contact the Factory. Cable must have the following specifications:
 - Braided shield or foil shield with drain wire
 - Shield must be wired to ground at indoor unit
 - 22-18AWG stranded tinned copper
 - Twisted pair (minimum 4 twists per foot)
 - Low Capacitance (15pF/FT or less)
 - Must be rated to meet local codes and conditions
 - EXAMPLES BELDEN 89207 (PLENUM RATED), OR ALPHA WIRE 6454 CATEGORY 5, 5E, OR HIGHER
- 14) Do not run in same conduit, raceway, or chase as high voltage wiring.
- 15) For CANbus network lengths greater than 450FT (137M) call Factory.



LIEBERT® CRV

ELECTRICAL FIELD CONNECTIONS DESCRIPTIONS

600mm (24in.) MODELS

ELECTRICAL CONNECTIONS FOR OPTIONAL FEATURES

16) **Condensate pump high water alarm** (available when optional pump is installed) - On pump high water indication, normally open dry contact is closed across terminals 88 & 89 for remote indication. 1 AMP, 24VAC max load. Use Class 1 field supplied wiring.

17) **Liebert® LiquiTect shutdown and dry contact** (available when optional Liebert® LiquiTect sensor is installed) – On Liebert® LiquiTect activation, normally open dry contact is closed across terminals 58 & 59 for remote indication. The Liebert® LiquiTect sensor notifies Liebert® iCOM™ of indication through terminals 60 & 61. 1 AMP, 24VAC max load. Use Class 1 field supplied wiring.

18) **Reheat and humidifier lockout** – Remote 24VAC required at terminals 82 & 83 for lockout of reheat and humidifier.

19) **Additional Common Alarm** - On any alarm, one additional normally open dry contact is closed across terminals 94 & 95 for remote indication. 1 AMP, 24VAC max load. Use Class 1 field supplied wiring.

NOTE: Refer to specification sheet for total unit full load amps, wire size amps and max overcurrent protective device size.

The 600mm (24in.) CRV Model is available in

A = 460V / 3ph / 60Hz (600 mm [24 in.]

C = 208V / 3ph / 60Hz (600 mm [24 in.]

Important note for 460V rated Liebert® CRV units (CR*****A)

The electronically commutated (EC) motors included in the Liebert® CRV unit are suitable for connection to an electrical service providing input power to the unit with 300V or less line to ground potential only.

Acceptable unit input electrical service for 460V (480V) nominal units

- Solidly grounded

Un-acceptable unit input electrical service for 460V (480V) nominal units

- wye with high resistance (or impedance) ground
- delta without ground or with floating ground
- delta with corner ground
- delta with grounded center tap

ELECTRICAL FIELD CONNECTIONS DESCRIPTIONS

600mm (24in.) MODELS

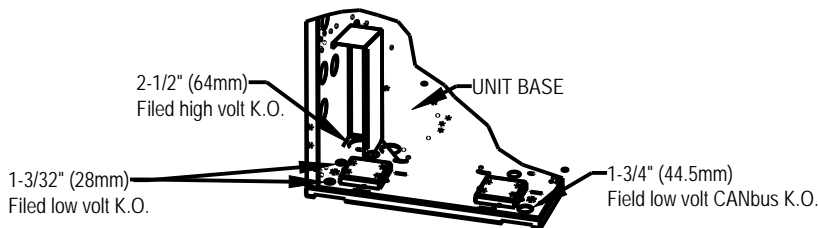
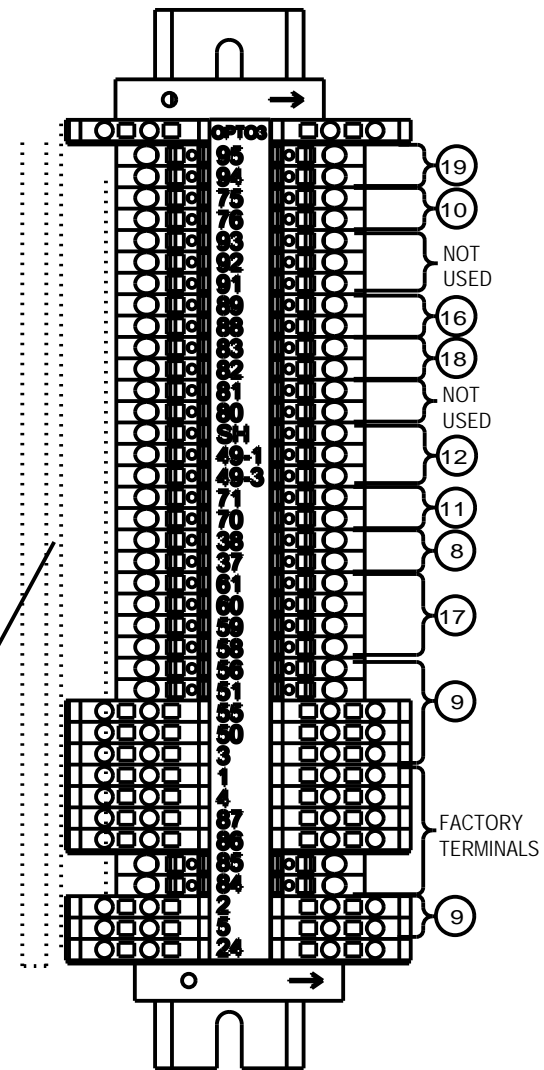
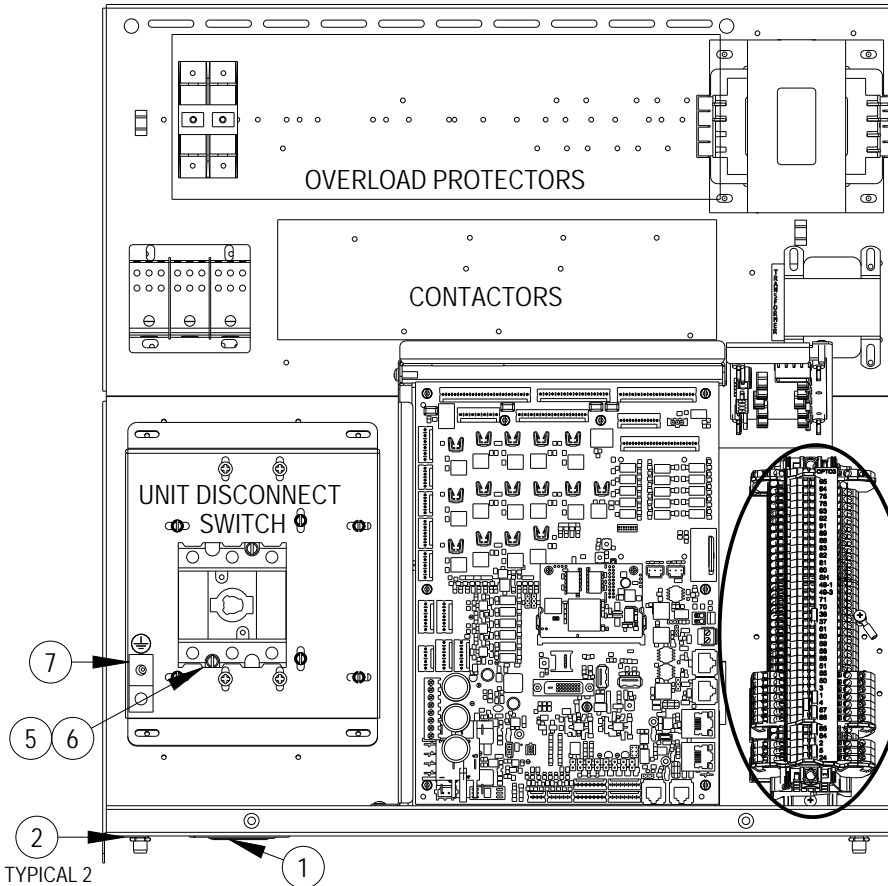
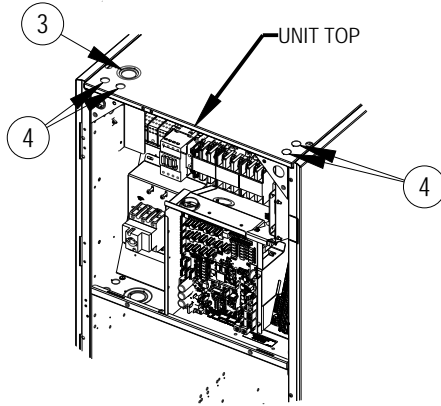

CANbus & INTERLOCK CONNECTIONS BETWEEN 600mm (24in.) UNIT & LIEBERT® MC (PREMIUM)

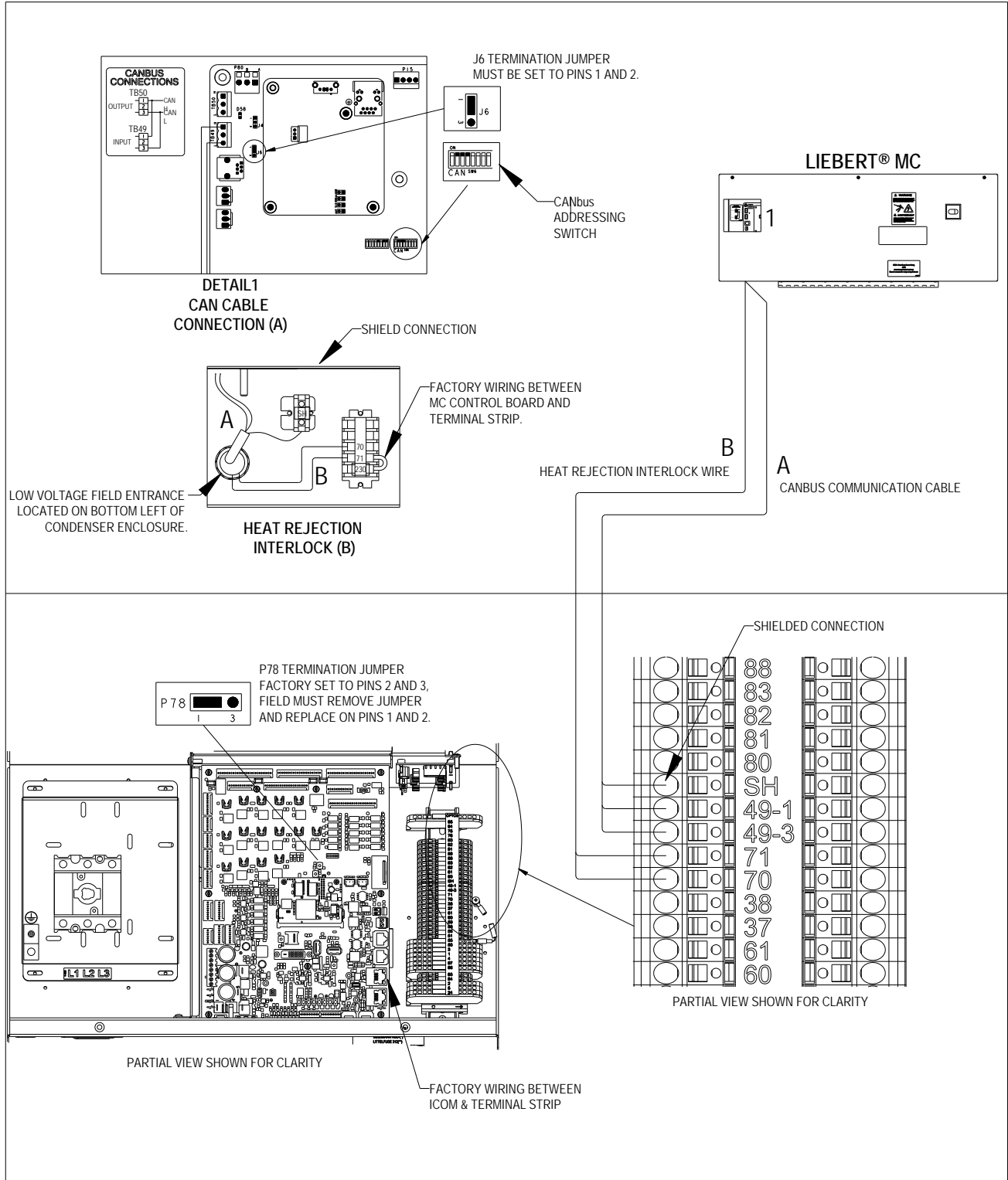



LIEBERT® CRV

CANbus & INTERLOCK CONNECTIONS BETWEEN 600mm (24in.) UNIT & LIEBERT® MC (PREMIUM)

COMPONENT NOTES:

1. COMPONENT APPEARANCE, ORIENTATION, AND POSITION MAY VARY
TERMINAL NAMES AND CALLOUTS REMAIN CONSTANT.
2. ALL CIRCUITS TO THESE CONNECTION POINTS ARE CLASS 2.

CAN & CABLE NOTES (A):

1. CABLE MUST HAVE THE FOLLOWING SPECIFICATIONS:
 - BRAIDED SHIELD OR FOIL SHIELD WITH DRAIN WIRE
 - SHIELD MUST BE WIRED TO GROUND AT INDOOR UNIT
 - 22-18AWG STRANDED TINNED COPPER
 - TWISTED PAIR (MINIMUM 4 TWISTS PER FOOT)
 - LOW CAPACITANCE (15pF/FT OR LESS)
 - MUST BE RATED TO MEET LOCAL CODES AND CONDITIONS.
 - EXAMPLES BELDEN 89207 (PLENUM RATED), OR ALPHA WIRE 6454 CATEGORY 5, 5E, OR HIGHER.
2. DO NOT RUN IN SAME CONDUIT, RACEWAY, OR CHASE AS HIGH VOLTAGE WIRING.
3. FOR CANBUS NETWORK LENGTHS GREATER THAN 450FT(137M), CONTACT FACTORY.

INTERLOCK WIRE NOTES (B):

1. FIELD SUPPLIED WIRE
 - 2 CONDUCTOR 18AWG OR GREATER
 - RATED 600V
2. RUN FIELD SUPPLIED WIRES BETWEEN THE INDOOR UNIT AND THE CONDENSER.



LIEBERT® CRV

ELECTRICAL FIELD CONNECTIONS DESCRIPTIONS 300mm (12in.) MODELS

SAFETY INSTRUCTIONS: READ ALL SAFETY MESSAGES IN USER MANUAL
BEFORE STARTING ELECTRICAL CONNECTIONS

STANDARD ELECTRICAL CONNECTIONS (See unit views for item callouts)

- 1) **High voltage connection through the rear of the disconnect switch box** – 1-1/8" (28.6mm) & 1-3/4" (44.5mm) diameter concentric knockout.
- 2) **High voltage connection through the top of the unit** – 1-1/4" (32mm) & 1-3/4" (44mm) diameter concentric knockout.
- 3) **Electrical service (hard wired)** – Refer to serial tag information for unit electrical service requirement.
Three phase – 208/230V 60Hz
Three phase with Neutral – 460V 60Hz Wye (5 wire: 3 phase + neutral + ground).
Single phase – 208/230V 60Hz (Chilled Water only).
Connect to terminals on disconnect switch. Electrical service not by Liebert®. Use copper conductors only, Wire per local codes. Refer to specification sheet for total unit full load amps, wire size amps and max over current protective device size.
- 4) **Electrical service (cord connected)** – Refer to serial tag information for unit electrical service requirement.
Single phase – 120V 60Hz (Chilled Water only). 1-3/4" (44mm) diameter knockout provided in the top and bottom of the unit for the power cord to exit the unit. The power cord is Liebert® supplied with a L5-20 plug.
- 5) **Factory installed locking Disconnect Switch**
- 6) **Earth ground** - Terminal for field supplied earth grounding wire.
- 7) **Low voltage connection through the bottom of the unit** - Quantity (2) 7/8" (22mm) diameter knockouts, not shown.
- 8) **Low voltage connection through the top of the unit** - Quantity (2) 7/8" (22mm) diameter knockouts.
- 9) **Remote unit shutdown** - Replace existing jumper between terminals 37 & 38 with field supplied normally closed switch having a minimum 75VA, 24VAC rating. Use field supplied Class 1 wiring.
- 10) **Customer alarm inputs** - Terminals for field supplied, normally closed contacts, having a minimum 75VA, 24VAC rating, between terminals 3 & 50, 2 & 51, 5 & 55, or 3 & 56. Use field supplied Class 1 wiring. Terminals 5 & 55 not available when optional Condensate Pump is installed.
- 11) **Common alarm** - On any alarm, normally open dry contact is closed across terminals 75 & 76 for remote indication. 1 AMP, 24VAC max load. Use Class 1 field supplied wiring.
- 12) **Heat rejection interlock** - On any call for compressor operation, normally open dry contact is closed across terminals 70 & 71 to heat rejection equipment. 1 AMP, 24VAC max load. Use Class 1 field supplied wiring.

CANbus ELECTRICAL CONNECTIONS

- 13) **CANbus connector** – Terminal block with terminals 49-1 (CAN-H) and 49-3 (CAN-L) + SH (shield connection). The terminals are used to connect the CANbus communication cable (provided by others) from the indoor unit to the Liebert® MC.
- 14) **CANbus cable** – CANbus cable provided by others to connect to the outdoor condenser. No special considerations are required when the total external cable connection between the indoor unit and outdoor unit(s) is less than 450FT (137M). For total external cable connections greater than 450FT (137M) but less than 800FT (243M) a CANbus isolator is required. Contact the Factory.
Cable must have the following specifications:
 - Braided shield or foil shield with drain wire
 - Shield must be wired to ground at indoor unit
 - 22-18AWG stranded tinned copper
 - Twisted pair (minimum 4 twists per foot)
 - Low Capacitance (15pF/FT or less)
 - Must be rated to meet local codes and conditions
 - EXAMPLES BELDEN 89207 (PLENUM RATED), OR ALPHA WIRE 6454 CATEGORY 5, 5E, OR HIGHER
- 15) Do not run in same conduit, raceway, or chase as high voltage wiring.
- 16) For CANbus network lengths greater than 450FT (137M) call Factory.



LIEBERT® CRV

ELECTRICAL FIELD CONNECTIONS DESCRIPTIONS

300mm (12in.) MODELS

SAFETY INSTRUCTIONS: READ ALL SAFETY MESSAGES IN USER MANUAL
BEFORE STARTING ELECTRICAL CONNECTIONS

ELECTRICAL CONNECTIONS FOR OPTIONAL FEATURES (See unit views for item callouts)

- 17) **Condensate pump high water alarm** (available when optional pump is installed) - On pump high water indication, normally open dry contact is closed across terminals 88 & 89 for remote indication. 1 AMP, 24VAC max load. Use Class 1 field supplied wiring.
- 18) **Liebert® LiquiTect shutdown and dry contact** (available when optional Liebert® LiquiTect sensor is installed) - On Liebert® LiquiTect activation, normally open dry contact is closed across terminals 58 & 59 for remote indication. The Liebert® LiquiTect sensor notifies Liebert® iCOM™ of indication through terminals 60 & 61. 1 AMP, 24VAC max load. Use Class 1 field supplied wiring.
- 19) **Additional Common Alarm** - On any alarm, one additional normally open dry contact is closed across terminals 94 & 95 for remote indication. 1 AMP, 24VAC max load. Use Class 1 field supplied wiring.

ELECTRICAL FIELD CONNECTIONS DESCRIPTIONS

300mm (12in.) MODELS

DISCONNECT VIEWS

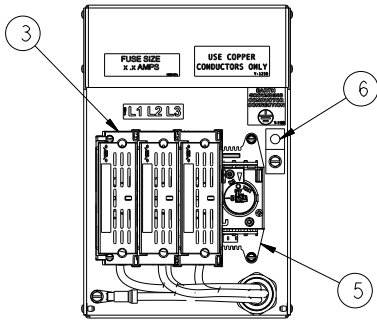

208/230V 3 phase

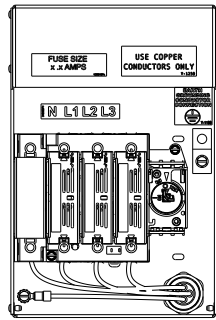

460V wye
(3 phase + neutral + ground)

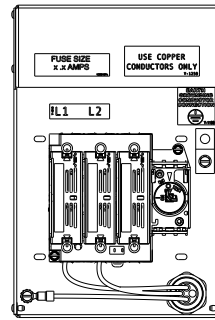

208/230V 1 phase
(CW only)

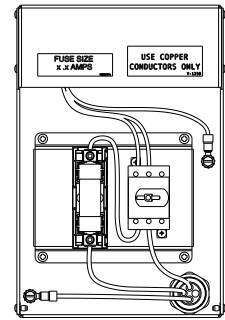

120V cord connected
(CW only)

POWER SUPPLY REQUIREMENTS FOR 460V CRV 300 mm (12in.) UNITS

460V Wye Power Supply Connection
(3 phase + Neutral + Ground)

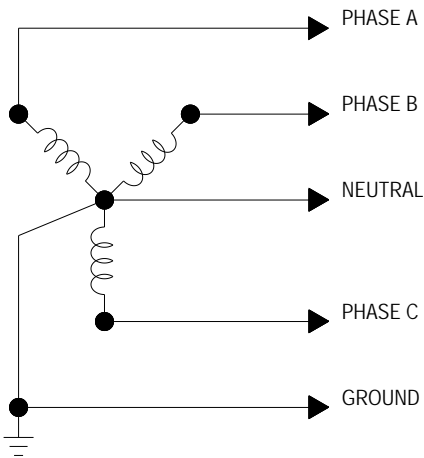

460V Delta Power Supply Connection

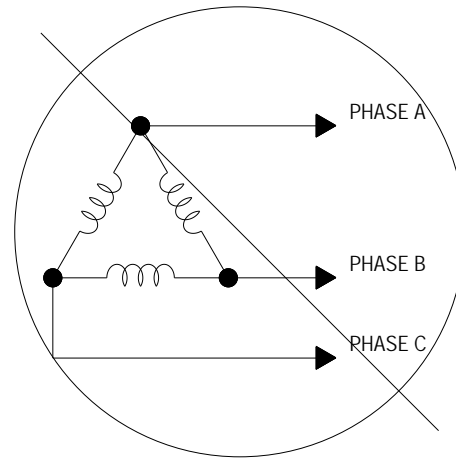

NOTE

The 460 volt Liebert® CRV 300 mm (12in.) unit is designed to operate with Wye-connected power with a solidly grounded neutral. It will not operate properly with Wye-connected power with high-resistance (or impedance) ground or with Delta-connected power.

Acceptable Power Supplies—460V Nominal Units

- 460V wye with solidly grounded neutral and 277V line-to-neutral

Unacceptable Power Supplies— 460V Nominal Units

- Wye with high-resistance (or impedance) ground
- Delta without ground or with floating ground
- Delta with corner ground
- Delta with grounded center tap

ELECTRICAL FIELD CONNECTIONS DESCRIPTIONS

300mm (12in.) MODELS

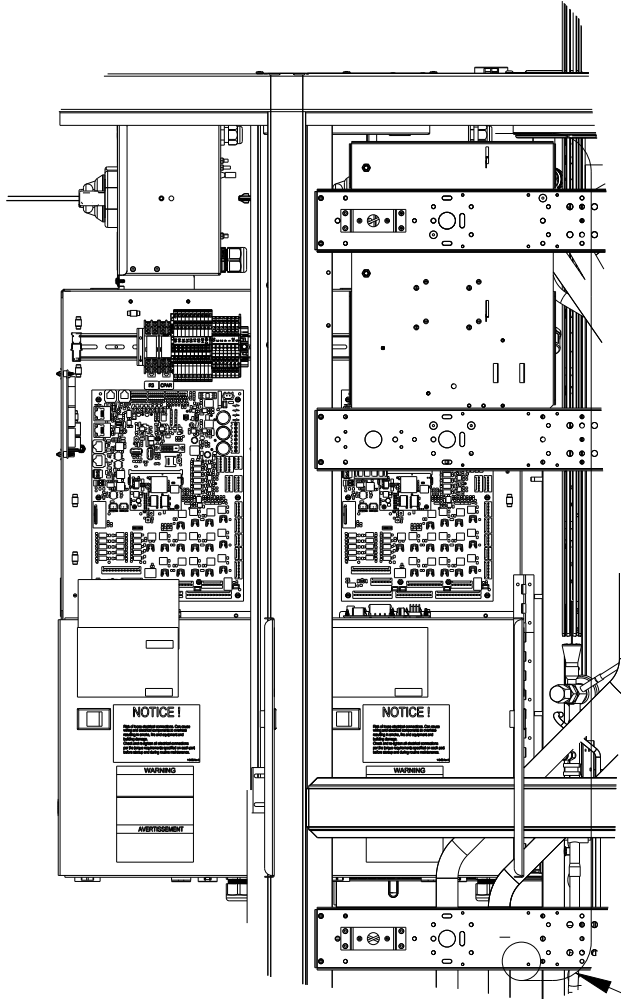

MAIN POWER CORD ROUTING - 120V CW UNITS

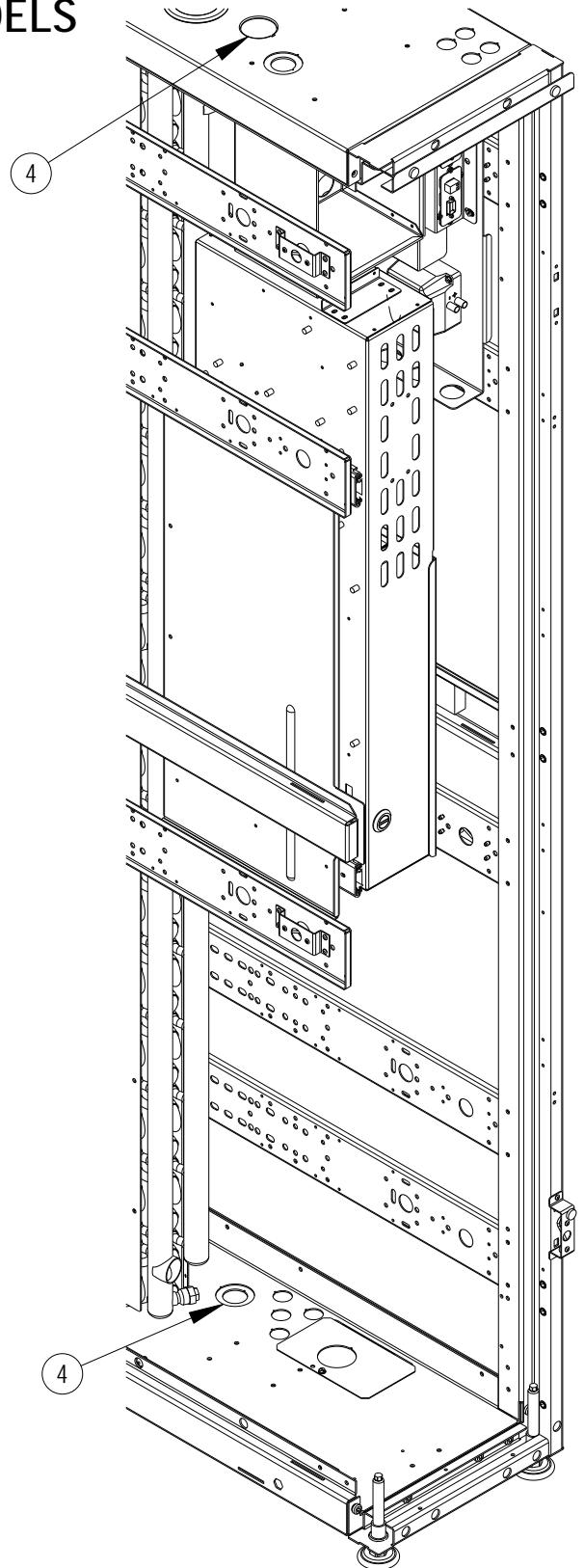

CANbus & INTERLOCK CONNECTIONS BETWEEN 300mm (12in.) UNIT & LIEBERT® MC (PREMIUM)

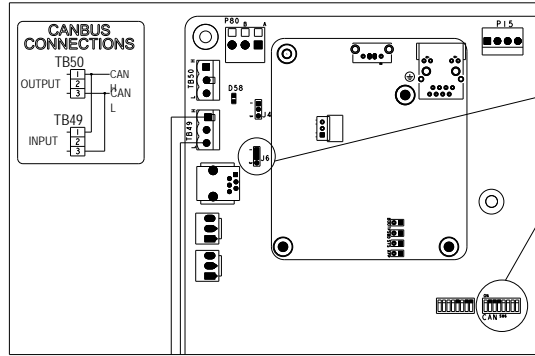

DETAIL 1
CAN CABLE CONNECTION (A)

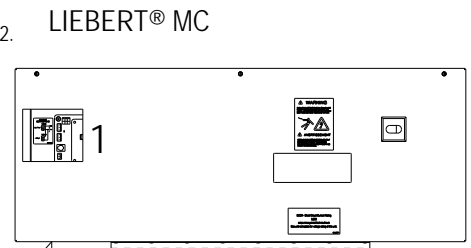
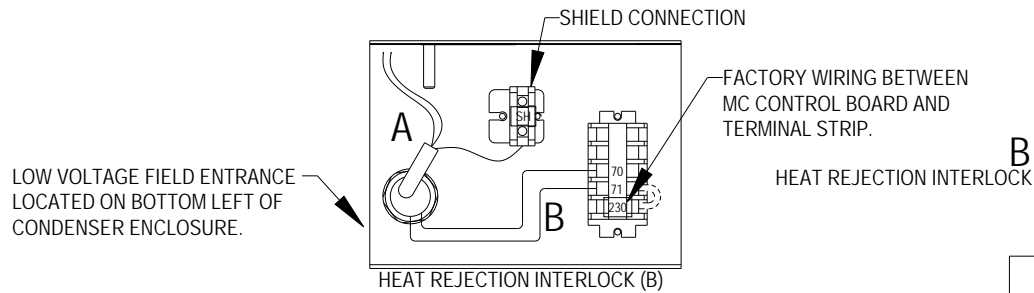

A CANbus CABLE CONNECTION

COMPONENT NOTES:

1. COMPONENT APPEARANCE, ORIENTATION AND POSITIONING MAY VARY. TERMINAL NAMES AND CALLOUTS REMAIN CONSTANT.
2. ALL CIRCUITS TO THESE CONNECTION POINTS ARE CLASS 2.

CAN & CABLE NOTES (A):

1. CABLE MUST HAVE THE FOLLOWING SPECIFICATIONS:
 - BRAIDED SHIELD OR FOIL SHIELD WITH DRAIN WIRE
 - SHIELD MUST BE WIRED TO GROUND AT INDOOR UNIT
 - 22-18AWG STRANDED TINNED COPPER
 - TWISTED PAIR (MINIMUM 4 TWISTS PER FOOT)
 - LOW CAPACITANCE (15pF/FT OR LESS)
 - MUST BE RATED TO MEET LOCAL CODES AND CONDITIONS.
 - EXAMPLES BELDEN 89207 (PLENUM RATED), OR ALPHA WIRE 6454 CATEGORY 5, 5E, OR HIGHER.
2. DO NOT RUN IN SAME CONDUIT, RACEWAY, OR CHASE AS HIGH VOLTAGE WIRING.
3. FOR CANBUS NETWORK LENGTHS GREATER THAN 450FT(137M) CONTACT FACTORY.

INTERLOCK WIRE NOTES (B):

1. FIELD SUPPLIED WIRE
 - 2 CONDUCTOR 18AWG OR GREATER
 - RATED 600V
2. RUN FIELD SUPPLIED WIRES BETWEEN THE INDOOR UNIT AND THE CONDENSER.

CRV300 INDOOR UNIT

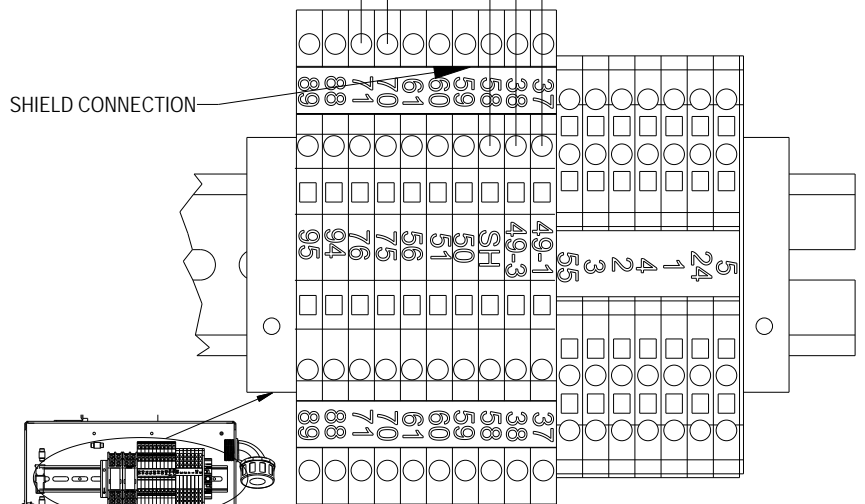

PARTIAL VIEW SHOWN FOR CLARITY

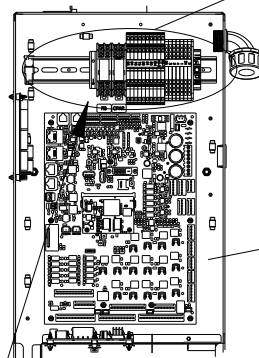

FACTORY WIRING BETWEEN ICOM AND TERMINAL STRIP.

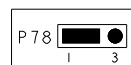

P78 TERMINATION JUMPER
FACTORY SET TO PINS 2 AND 3,
FIELD MUST REMOVE JUMPER
AND REPLACE ON PINS 1 AND 2.

LOW VOLTAGE FIELD WIRING ROUTING 300mm (12in.) ALL MODELS

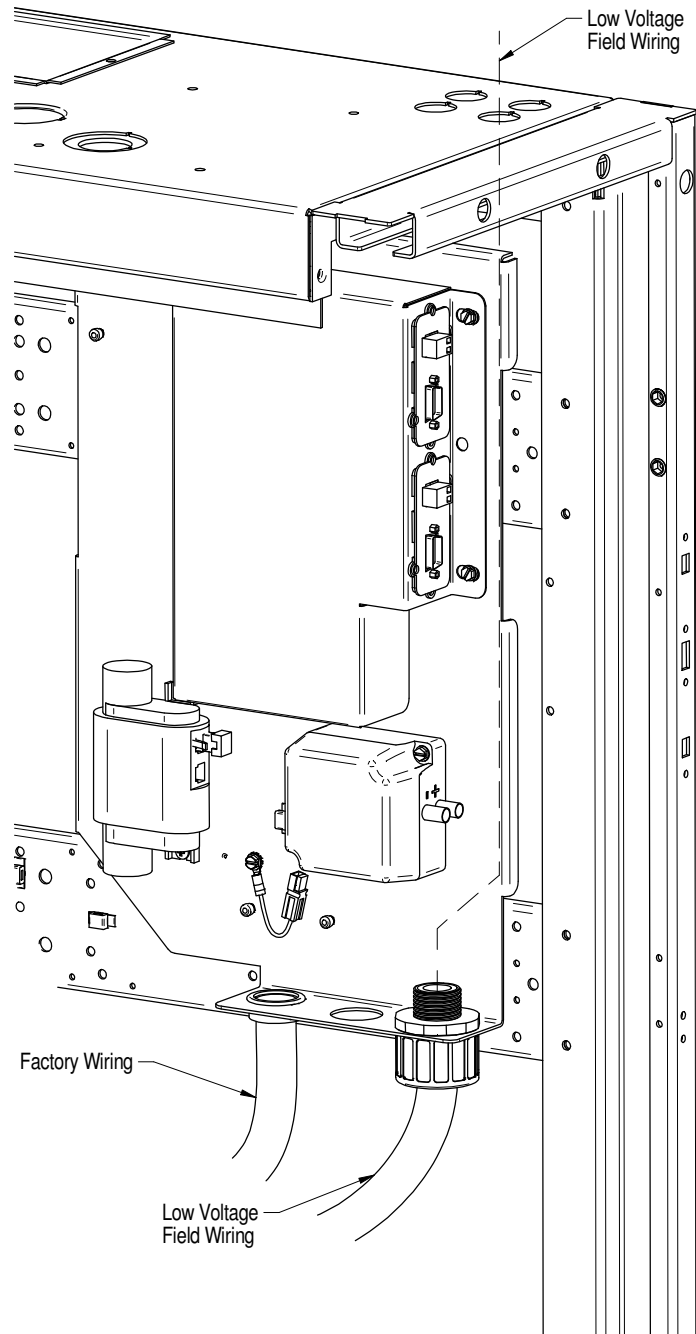

POWER CABLE ROUTING BOTTOM ENTRY 300mm (12in.) AIR COOLED & WATER GLYCOL COOLED MODELS

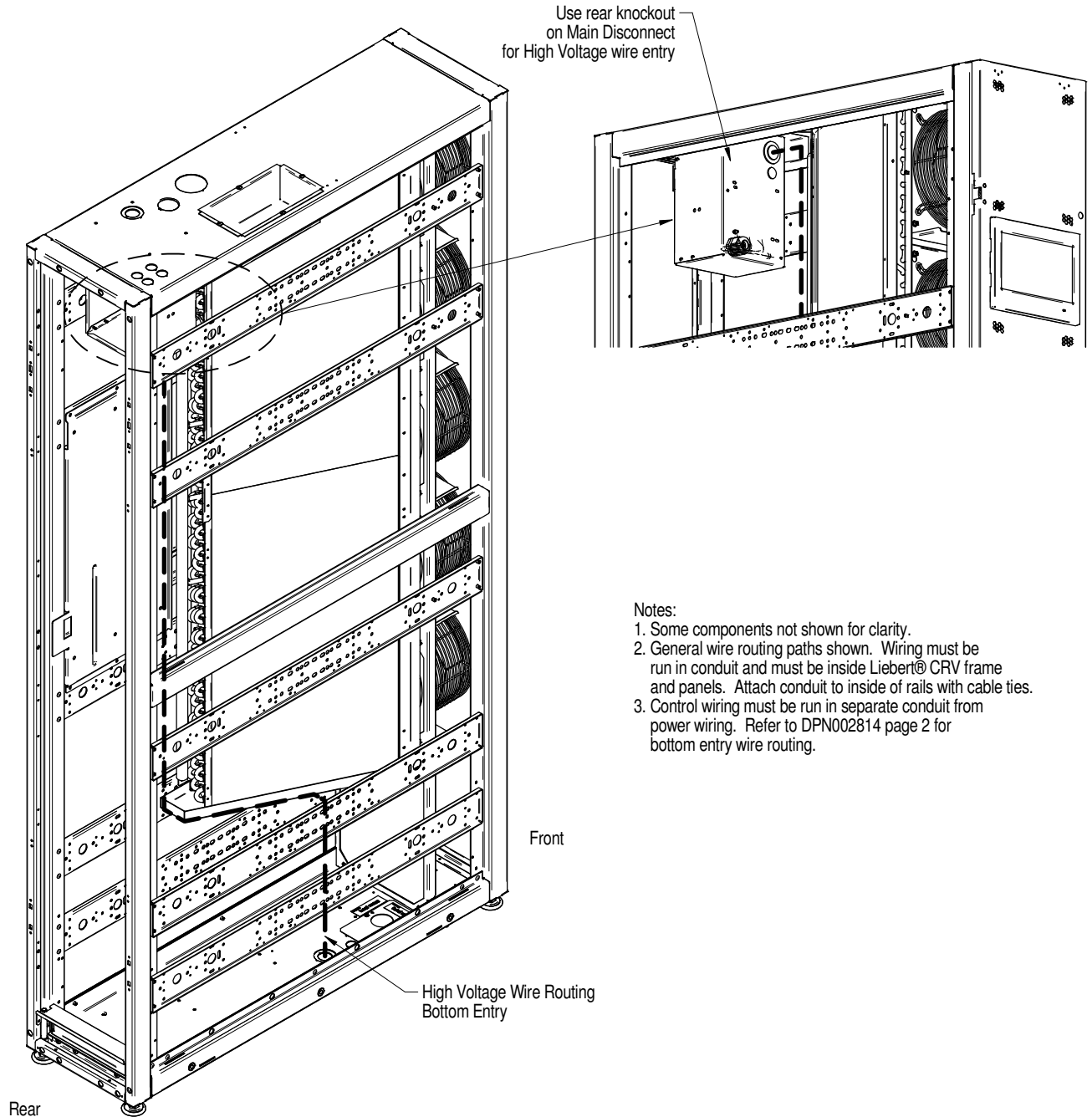

Notes:

1. Some components not shown for clarity.
2. General wire routing paths shown. Wiring must be run in conduit and must be inside Liebert® CRV frame and panels. Attach conduit to inside of rails with cable ties.
3. Control wiring must be run in separate conduit from power wiring. Refer to DPN002814 page 2 for bottom entry wire routing.

POWER CABLE ROUTING BOTTOM ENTRY 300mm (12in.) CHILLED WATER MODELS

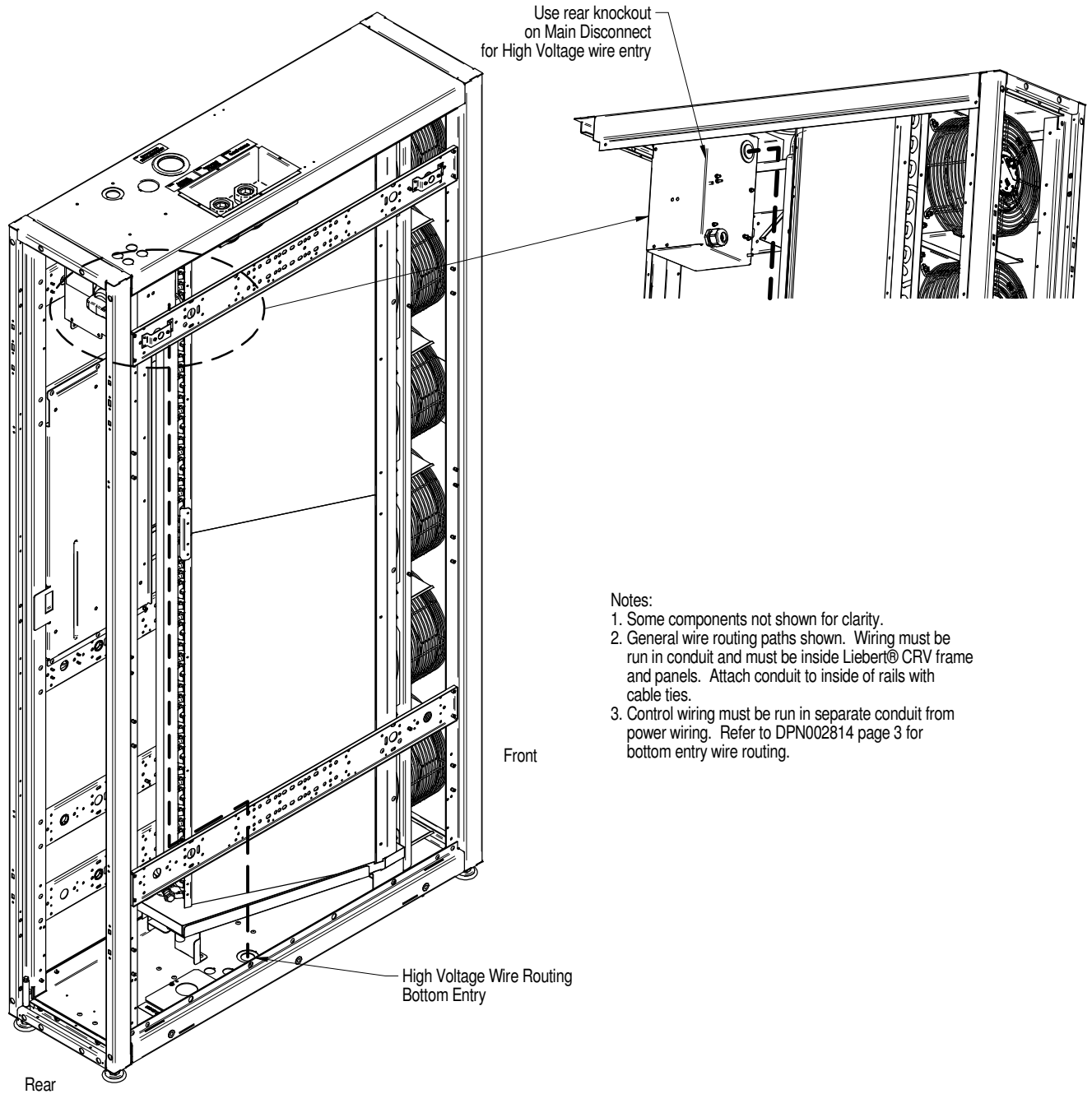

Notes:

1. Some components not shown for clarity.
2. General wire routing paths shown. Wiring must be run in conduit and must be inside Liebert® CRV frame and panels. Attach conduit to inside of rails with cable ties.
3. Control wiring must be run in separate conduit from power wiring. Refer to DPN002814 page 3 for bottom entry wire routing.

Connect with Vertiv on Social Media



<https://www.facebook.com/vertiv/>



<https://www.instagram.com/vertiv/>



<https://www.linkedin.com/company/vertiv/>



<https://www.x.com/Vertiv/>



Vertiv.com | Vertiv Headquarters, 505 N. Cleveland Ave., Westerville, OH, 43082, USA

© 2026 Vertiv Group Corp. All rights reserved. Vertiv™ and the Vertiv logo are trademarks or registered trademarks of Vertiv Group Corp. All other names and logos referred to are trade names, trademarks or registered trademarks of their respective owners. While every precaution has been taken to ensure accuracy and completeness here, Vertiv Group Corp. assumes no responsibility, and disclaims all liability, for damages resulting from use of this information or for any errors or omissions.

SL-11975_REV23_06-26