



Vertiv™ CoolChip CDU 600

Operation and Maintenance Guide

The information contained in this document is subject to change without notice and may not be suitable for all applications. While every precaution has been taken to ensure the accuracy and completeness of this document, Vertiv assumes no responsibility and disclaims all liability for damages result from use of this information or for any errors or omissions.

Refer to local regulations and building codes relating to the application, installation, and operation of this product. The consulting engineer, installer, and/or end user is responsible for compliance with all applicable laws and regulations relation to the application, installation, and operation of this product. This information contained in this document must be used in conjunction with the Installation and Commissioning Guide and the Application and Planning Guide.

The products covered by this instruction manual are manufactured and/or sold by Vertiv. This document is the property of Vertiv and contains confidential and proprietary information owned by Vertiv. Any copying, use, or disclosure of it without the written permission of Vertiv is strictly prohibited.

Names of companies and products are trademarks or registered trademarks of the respective companies. Any questions regarding usage of trademark names should be directed to the original manufacturer.

Technical Support Site

If you encounter any installation or operational issues with your product, check the pertinent section of this manual to see if the issue can be resolved by following outlined procedures.

Visit <https://www.vertiv.com/en-us/support/> for additional assistance.

TABLE OF CONTENTS

1 Important Safety Information	1
1.1 General	5
1.2 Installation/Handling	5
1.3 Application	6
1.4 Electrical Connection	6
1.5 Replacement Parts	7
1.6 Waste Disposal	7
1.7 Documentation	7
2 Agency	9
2.1 Product Standards and Approvals	9
2.2 ROHS 3 Compliance	9
3 Product Description	11
3.1 General	11
3.1.1 Product Model Nomenclature	11
4 Operation	15
4.1 Controller Overview	15
4.2 User Interface	15
4.2.1 Home Screen	15
4.2.2 Main Menu	16
4.2.3 Status Screen	17
4.2.4 Data Curves Screen (Real Time Update)	22
4.2.5 Alarm Screen	23
4.2.6 Login Screen	24
4.2.7 Setup Screen	25
4.2.8 Configuration Screen	29
4.2.9 Service Screen	34
4.2.10 Diagnostics Screen	37
4.2.11 Group Control Status Screen	39
4.2.12 Ethernet and IP Communication Status Screen	40
4.2.13 Calibration Screen	41
4.3 Automatic Operation	42
4.3.1 Primary Circuit Operation	42
4.3.2 Secondary Circuit Operation	43
4.4 Temperature Control Loop	48
4.4.1 PI Control	48
4.4.2 PID Control	49
4.5 Alarm Management	49

4.6 Troubleshooting Alarms	51
5 CANbus Communication Troubleshooting	59
5.1 Temperature Sensor Graph	59
5.2 Manual Operation of Cooling Valve	60
5.3 Group Control	60
5.3.1 Group Control—Network Cabling	61
5.3.2 Group Control—Network Termination Resistors	62
5.3.3 Group Control—Network Addresses	63
5.3.4 Group Control—Start Sequence from Power Up	63
5.3.5 Group Control—Controls	64
5.3.6 Group Control—Unit Rotation and Standby Units	64
5.3.7 Group Control—Failover Offset	64
5.3.8 Group Control—Failure Modes	64
6 Maintenance	67
6.1 Fluid Specifications	67
6.2 Planned Preventative Maintenance	68
6.2.1 Special Tools and Equipment	68
6.2.2 Visual Checks for Damage and Leakage	68
6.2.3 General Settings	69
6.2.4 Controller Checks	69
6.2.5 Sensor Checks	69
6.2.6 Fluid Checks	69
6.2.7 Functional Checks	69
6.3 Primary Filter Service (if Fitted)	70
6.4 Secondary Filter Service (if Fitted)	70
6.5 Unit Draining	73
Appendices	75
Appendix A: Technical Support and Contacts	75
Appendix B: Submittal Drawings	77
Appendix C: Notes	79
Appendix D: Disposal Procedure	81

1 Important Safety Information

SAVE THESE INSTRUCTIONS

This manual contains important instructions that should be followed during operation and maintenance of the Vertiv™ CoolChip CDU 600.



WARNING! Always check for water, waste, or any liquid accumulation on the floor or beneath the unit before and after operation or maintenance. These substances can create slip hazards and may damage the equipment. Ensure the area is clean, dry, and free of obstructions to maintain a safe working environment.



WARNING! Arc flash and electric shock hazard. Can cause serious injury or death. Building and equipment damage may also result. Disconnect all local and remote electric power supplies and wear appropriate, OSHA-approved personal protective equipment (PPE) per NFPA 70E before working within the electric control enclosure. Customer must provide earth ground to unit, per NEC, CEC and local codes, as applicable.

Verify with a voltmeter that power is Off. The controller does not isolate power from the unit, even in the “Unit Off” mode. Some internal components still require and receive power even during the Unit Off mode of the controller. The factory-supplied, optional disconnect switch is inside the unit. The line side of this switch contains live high voltage. The only way to ensure that there is NO voltage inside the unit is to install and open a remote disconnect switch. Refer to unit electrical schematic.

Before proceeding with installation, read all instructions, verify that all the parts are included and check the nameplate to be sure the voltage matches available utility power. Follow all local codes.



WARNING! Risk of electric shock. Can cause serious injury or death. Building and equipment damage may also result. Open all local and remote electric power supply disconnect switches and verify that power is off with a voltmeter before working within any electric connection enclosures. The controller does not isolate power from the unit, even in the Unit Off mode. Some internal components require and receive power even during the Unit Off mode of the controller. The controller does not isolate power from the unit, even in the Unit Off mode. Some internal components require and receive power even during the Unit Off model of the controller.

Installation, service, and maintenance work must be performed only by properly trained and qualified personnel and in accordance with applicable regulations and manufacturers’ specifications. Opening or removing the covers to any equipment may expose personnel to lethal voltages within the unit even when it is apparently not operating and the input wiring is disconnected from the electrical source.



WARNING! Risk of short circuits and electric shock. Can cause serious injury or death. Building and equipment damage can result from cut insulation or damaged wires. Can cause overheated wiring, smoke, fire, activation of fire suppression systems and EMS personnel, and loss of power to fans. Verify that all wiring connections are tight and that all wiring is contained within the junction box prior to closing and securing the cover.

Insert CSA-certified or UL-listed bushings into holes and/or knockouts used to route wiring through metal panels to protect the wire insulation from contact with sheet metal edges.



WARNING! Risk of improper wire sizing/rating and loose electrical connections causing overheated wire and electrical connection terminals resulting in smoke or fire. Can cause serious injury or death. Building and equipment damage may also result. Use correctly sized copper wire only and verify that all electrical connections are tight before turning power On. Check all electrical connections periodically and tighten as necessary.



WARNING! Risk of improper moving. Can cause serious injury or death. Building and equipment damage may also result. Use only lifting equipment that is rated for the unit weight by an OSHA-certified rating organization. The center of gravity varies depending on the unit size and selected options. The slings must be equally spaced on either side of the center of gravity indicator. Shipping weights and unit weights are specified in the Application and Planning Guide. Use the center of gravity indicators on the unit to determine the position of the slings.



CAUTION: Risk of contact with extremely hot or cold surfaces. Can cause injury. Verify that all components have reached a temperature that is safe for human contact or wear appropriate, OSHA-approved PPE before working with the electric connection enclosures or unit cabinet. Perform maintenance only when the system is de-energized and component temperatures have become safe for human contact.



CAUTION: Risk of contact with sharp edges, splinters and exposed fasteners. Can cause injury. Only properly trained and qualified personnel wearing appropriate, OSHA-approved PPE should attempt to move, lift, remove packaging from or prepare the unit for installation.



CAUTION: Risk of improper handling heavy and lengthy parts. Can cause injury. Building and equipment damage may also result. Cabinet panels can exceed 5 ft. (1.5 m) in length and weigh more than 35 lb (15.9 kg). Follow relevant OSHA lifting recommendations and consider using a two-person lift for safe and comfortable removal and installation of cabinet panels. Only properly trained and qualified personnel wearing appropriate, OSHA-approved PPE should attempt to remove or install cabinet panels.



CAUTION: Risk of improper piping installation, leak checking, fluid chemistry and fluid maintenance. Can cause injury. Building and equipment damage may also result. Installation and service of this equipment should be done only by qualified personnel who have been specially-trained in the installation of air-conditioning equipment and who are wearing appropriate, OSHA-approved PPE.



CAUTION: Risk of improper power supply connection. Can cause equipment damage and loss of warranty coverage. Prior to connecting any equipment to a main or alternate power source (for example back-up generator systems) for start-up, commissioning, testing, or normal operation, ensure that these sources are correctly adjusted to the nameplate voltage and frequency of all equipment to be connected. Also, ensure that no three-phase sources are single-phased at any time. See transformer label for primary tap connections. Installer will need to change transformer primary taps if applied unit voltage is other than pre-wired tap voltage.



CAUTION: Risk of improper electrical connection of three-phase input power. Can cause backward pump rotation and unit damage. Service technicians should use a gauge set on the system during the initial start up to verify that the three-phase power is connected properly. Three-phase power must be connected to the unit line voltage terminals in the proper sequence so that the pump rotates in the proper direction. Incoming power must be properly phased to prevent pump from running backward. We recommend checking the unit's phasing with proper instrumentation to ensure that the power connections were made correctly. We also recommend verifying discharge and suction pressures during start up to ensure that the pumps are running in the correct direction.

NOTICE

Risk of no flow condition. Can cause equipment damage. Do not leave the water/coolant fluid supply circuit in a no flow condition. Idle fluid allows the collection of sediment that prevents the formation of a protective oxide layer on the inside of the tubes. Keep unit switched On and water/ coolant fluid supply circuit system operating continuously. In multiple unit teams, allow standby units to enter the rotation automatically or schedule regular manual rotations.

NOTICE

Risk of clogged or leaking drain lines and leaking water supply lines. Can cause equipment and building damage. Lines and joints must be inspected regularly. Improper installation, application, and service practices can result in water leakage from the unit. Water leakage can result in severe property damage and loss of critical data center equipment. Do not locate directly above any equipment that could sustain water damage.

Vertiv recommends installing monitored leak detection equipment for the unit and supply return lines.

NOTICE

Risk of piping system corrosion and freezing fluids. Can cause leaks resulting in equipment and very expensive building damage. Heat exchangers and piping systems are at high risk of freezing and premature corrosion. Automotive antifreeze is unacceptable and must NOT be used in any fluid system. Use only coolant fluid solution that meets the requirements of recommended industry practices. Do not use galvanized pipe.

The system coolant fluid must be analyzed by a competent fluid treatment specialist before start up to establish the inhibitor and antifreeze solution requirement and evaluated at regularly scheduled intervals throughout the life of the system to determine the pattern of inhibitor depletion.

The fluid complexity and variants of required treatment programs make it extremely important to obtain the advice of a competent and experienced fluid treatment specialist and follow a regularly scheduled coolant-fluid system-maintenance program.

Fluid chemistry varies greatly as do the required additives, called inhibitors, that reduce the corrosive effect of the fluids on the piping systems and components.

The chemistry of the coolant fluid used must be considered, because some sources may contain corrosive elements that reduce the effectiveness of the inhibited formulation. Sediment deposits prevent the formation of a protective oxide layer on the inside of the coolant system components and piping. The coolant fluid must be treated and circulating through the system continuously to prevent the buildup of deposits and/or growth of sulfate reducing bacteria. Proper inhibitor maintenance must be performed to prevent corrosion of the system.

Consult fluid manufacturer for testing and maintenance of inhibitors.

Commercial grade coolant fluid is generally less corrosive to the common metals of construction than water itself. It will, however, assume the corrosivity of the coolant fluid from which it is prepared and may become increasingly corrosive with use if not properly inhibited.

Vertiv recommends installing a monitored fluid-detection system that is wired to activate the automatic closure of field installed coolant fluid supply and return shut off valves to reduce the amount of coolant fluid leakage and consequential equipment and building damage. The shut off valves must be sized to close off against the maximum coolant fluid system pressure in case of a catastrophic fluid leak.

NOTICE

Performing any work on the upper section of the unit requires the use of a suitable ladder or platform to ensure safe and stable access. Always use equipment that complies with local safety regulations and ensure that proper fall prevention measures are in place. Never attempt to reach or perform tasks at height without the appropriate support.

NOTICE

Risk of a catastrophic water circuit rupture. Can cause expensive building and equipment damage.

The overflow drain pan should have a drain line connected to it that flows to a floor drain or maintenance sink in case of a shutoff valve or leak detection system malfunction.

NOTICE

Risk of passageway interference. Can cause unit and/or structure damage. The unit may be too large to fit through a passageway while on or off the skid. Measure the unit and passageway dimensions, and refer to the installation plans prior to moving the unit to verify clearances.

NOTICE

Risk of damage from forklift. Can cause unit damage. Keep tines of the forklift level and at a height suitable to fit below the skid and/or unit to prevent exterior and/or underside damage.

NOTICE

Risk of improper storage. Can cause unit damage.

Keep the unit upright, indoors and protected from dampness, freezing temperatures and contact damage.

NOTICE

Risk of improper control circuits. Can cause equipment damage.

When using jumpers for troubleshooting, always remove jumpers when maintenance is complete. Jumpers left connected could override controls and cause equipment damage.

1.1 General

Mechanical and electrical equipment such as coolant distribution units (CDUs) present potential mechanical and electrical hazards. Adhere to all safety, installation, operation, and maintenance instructions. Any work on or use of the equipment should be carried out and/or supervised by personnel trained and qualified to work on this type of equipment by Vertiv. This product is designed to minimize all potential hazards by restricting access through unit casings, doors and covers while equipment is operational. Before performing any maintenance work, ensure the following:

1. Equipment is shut OFF.
2. Equipment and controls are disconnected from the electrical supply.
3. All rotating parts such as pumps and three-way valves have come to a rest.

If in doubt regarding safety, installation, operation or maintenance instructions, consult the manufacturer for clarification and advice.

1.2 Installation/Handling



WARNING! Risk of improper wiring, piping, moving, lifting and handling. Can cause serious injury or death. Building and equipment damage may also result. Installation and service of this equipment should be done only by qualified personnel who have been specially-trained in the installation of air-conditioning equipment and who are wearing appropriate, OSHA-approved PPE.



WARNING! Risk of improper moving. Can cause serious injury or death. Building and equipment damage may also result. Use only lifting equipment that is rated for the unit weight by an OSHA-certified rating organization. Shipping weights and unit weights are provided in the Application and Planning Guide.



WARNING! Risk of top-heavy unit falling over when improperly lifted or moved. Can cause serious injury or death. Building and equipment damage may also result. Read all of the following instructions and verify that all lifting and moving equipment is rated for the weight of the unit before attempting to move, lift, remove packaging from or prepare the unit for installation. Unit weights are specified in the Application and Planning Guide.



WARNING! Risk of unsecured unit falling off pallet. Can cause serious injury or death. Building and equipment damage may also result. The unit is on casters. Ensure that the unit and pallet is located on a flat surface before loosening the hardware securing the unit to its shipping pallet.



CAUTION: Risk of contact with sharp edges, splinters and exposed fasteners. Can cause injury. Only properly trained and qualified personnel wearing appropriate, OSHA-approved PPE should attempt to move, lift, remove packaging from or prepare the unit for installation.

NOTICE

Risk of passageway interference. Can cause unit and/or structure damage. The unit may be too large to fit through a passageway while on or off the skid. Measure the unit and passageway dimensions, and refer to the installation plans prior to moving the unit to verify clearances.

NOTICE

Risk of passageway interference. Can cause unit and/or structure damage. The unit may be too large to fit through a passageway while on or off the skid. Measure the unit and passageway dimensions, and refer to the installation plans prior to moving the unit to verify clearances.

Installation and operation must be conducted in accordance with local and national regulations and normal codes of good practice. When moving or lifting the product, caution must be observed to ensure the safety of personnel. Only the appropriate lifting equipment must be used.

1.3 Application

This product is for indoor use only and must be used only for the application it was designed for in consultation with Vertiv. This product must not be used in a hazardous environment.

The flow sensor is for indication only, it is not used for any control or alarm functions nor should it be depended on for consequential actions. Differential pressure is the principle means of PQ control for both a single unit and in group operation. Instrumentation and reporting in this aspect is accurate and reliable.

1.4 Electrical Connection



WARNING! This unit is powered by high voltage. Serious injury or death can occur. Power supplied to this product must be provided with an external means of isolation.



WARNING! Arc flash and electric shock hazard. Can cause serious injury or death. Building and equipment damage may also result. Disconnect all local and remote electric power supplies and wear appropriate, OSHA-approved personal protective equipment (PPE) per NFPA 70E before working within the electric control enclosure. Customer must provide earth ground to unit, per NEC, CEC and local codes, as applicable.

Verify with a voltmeter that power is Off. The controller does not isolate power from the unit, even in the “Unit Off” mode. Some internal components still require and receive power even during the Unit Off mode of the controller. The factory-supplied, optional disconnect switch is inside the unit. The line side of this switch contains live high voltage. The only way to ensure that there is NO voltage inside the unit is to install and open a remote disconnect switch. Refer to unit electrical schematic.

Before proceeding with installation, read all instructions, verify that all the parts are included and check the nameplate to be sure the voltage matches available utility power. Follow all local codes.



WARNING! Risk of electric shock. Can cause serious injury or death. Building and equipment damage may also result. Open all local and remote electric power supply disconnect switches and verify that power is off with a voltmeter before working within any electric connection enclosures. The controller does not isolate power from the unit, even in the Unit Off mode. Some internal components require and receive power even during the Unit Off mode of the controller. The controller does not isolate power from the unit, even in the Unit Off mode. Some internal components require and receive power even during the Unit Off model of the controller.

Installation, service, and maintenance work must be performed only by properly trained and qualified personnel and in accordance with applicable regulations and manufacturers' specifications. Opening or removing the covers to any equipment may expose personnel to lethal voltages within the unit even when it is apparently not operating and the input wiring is disconnected from the electrical source.

Electrical connections should be carried out in accordance with local and national regulations by a qualified electrician. Never make any electrical connections inside, or to the unit unless the electricity supply has been switched OFF at the disconnect (isolator).

1.5 Replacement Parts

Any parts replaced during maintenance or servicing must be the same specification as those being replaced and should only be obtained from Vertiv.

The use of incorrect replacement parts may affect the operation or reliability of the unit and invalidate any warranty.

1.6 Waste Disposal

Any waste or single use materials must be disposed of in a responsible manner and in strict adherence to local and national environmental regulations. For details, consult local environmental agencies.

1.7 Documentation

The Application and Planning Guide, Operation and Maintenance Guide, Installation and Commissioning Guide, maintenance, and service records must always remain with the unit.

This page intentionally left blank

2 Agency

2.1 Product Standards and Approvals

Vertiv products installed and operated in compliance with this document, the operation and maintenance guide and installation and commissioning guide conform to the Low Voltage directive 2014/35/EU, the EMC directive 2014/30/EU and the Pressure Equipment directive 2014/68/EU. As manufactured, Vertiv products are designed to comply with an IP21 rating. This product is in conformance with UL1995.



2.2 ROHS 3 Compliance

Vertiv certifies that this product manufactured and supplied by Vertiv is fully RoHS compliant in accordance with EU RoHS Directive EU 2015/863.



This page intentionally left blank

3 Product Description

Please refer to the following submittals located in [Submittal Drawings](#) on page 77.

Table 3.1 Submittals

Submittal Number	Title
20000180	Vertiv™ CoolChip CDU 600 Component Location Diagram with SS make up tank
20000033	Vertiv™ CoolChip CDU 600 Cabinet Dimensional Data
20000043	Vertiv™ CoolChip CDU 600 Piping Schematic with SS make up tank

3.1 General

This document describes the performance, possible configurations, application and specification of the CoolChip CDU 600.

The CDU 600 contains a secondary closed loop circuit that provides a supply of cooling fluid to equipment based on differential pressure, either through indirect cooling (rack mounted rear door heat exchangers) or direct cooling (cold plates at chip level).

The secondary circuit is a low pressure sealed system with the heat removed from the high heat density areas of IT equipment rejected to an external cooled fluid source (primary circuit) via a low pressure drop plate heat exchanger.

The secondary circuit ensures that the cooling fluid in the secondary network can be kept to a minimum volume, is closely controlled for flow, pressure, and temperature (with condensation control) and can be accurately maintained for fluid quality (with filtration and additives).

The primary cooling source can be a chilled water system (either dedicated or from building system), fluid cooler, cooling tower or dry air cooler, depending on the desired secondary temperature and heat transfer duty. Refer to the Primary (Facility) Circuit and Secondary Circuit in SL-07624 CoolChip CDU 600 Application and Planning Guide.

3.1.1 Product Model Nomenclature

The CDU 600 has a 29-digit model nomenclature configuration. The first seven digits are XDU0600.

Of the next 18 digits of the nomenclature, Digit 26 is used for an ETO, and the last three digits are factory digits. Refer to [Table 3.2](#) below.

Table 3.2 CDU 600 Model Number Digit Summary

Digit	Description
Digits 1 - 7	XDU0600 (Unit family)
Digit 8	Model Revision: A: Model A
Digit 9	Voltage Selection: Q: 400V, 50/60Hz (Europe and Asia), 3 phase A: 480V 60Hz (USA), 3 phase
Digit 10	Automatic Transfer Switch (ATS) 0: Standard power termination enclosure

Table 3.2 CDU 600 Model Number Digit Summary (continued)

Digit	Description
	1: Power termination enclosure with ATS
Digit 11	Controller A: Standard controller
Digit 12	Communication 1: Protocol: Modbus, BACnet, SNMPV2/V3, HTTP(S), webserver, NTP, SSH-CLI, SFTP
Digit 13	Display: 7: 7-in. touchscreen display
Digit 14	Secondary Circuit Fluid Monitoring: 0: None A: PH + conductivity (0-10,000 us/cm range) + turbidity (0-100 NTU)
Digit 15	Pump Configuration: 2: 2 Pumps
Digit 16	EMC Filter 1: Standard EMC filter 2: No EMC filter
Digit 17	Primary Connection from Facility T: Top connection B: Bottom connection
Digit 18	Primary filtration 0: None 1: Factory fitted (500 micron)
Digit 19	Primary Control Valve H: 3-way valve- 40 kV S: 3-way valve- 63 kV
Digit 20	Secondary Connection to Equipment T: Top connection B: Bottom Connection M: 6-way manifold header with 1-1/4 in. ball valve supply/double regulating valve return with factory fitted 1-in. hose barb
Digit 21	Secondary Filtration 0: None 1: Factory fitted (50 microns) 2: Factory fitted (25 microns)

Table 3.2 CDU 600 Model Number Digit Summary (continued)

Digit	Description
Digit 22	Pressure Relief Valve--Secondary Circuit 3: 3 bar pressure relief valve 4: 4 bar pressure relief valve 5: 5 bar pressure relief valve 6: 6 bar pressure relief valve
Digit 23	Reservoir N: SS reservoir with 3 stage fluid level detection
Digit 24	Packaging S: Seaworthy
Digit 25	SCCR 0: 65kA
Digit 26	ETO
Digits 27 through 29	Factory digits

This page intentionally left blank

4 Operation

4.1 Controller Overview

The CoolChip CDU 600 controller is designed to monitor and control the supply of cooling fluid to IT equipment in unattended data center environments. Secondary circuit cooling fluid is closely controlled for a defined temperature and differential pressure for optimum heat management.

When power is first applied to the unit, the touchscreen will illuminate and the pump inverter drives will energize. As the unit initializes, a logo is presented. When loaded, the displays defaults to the Home screen.

4.2 User Interface

4.2.1 Home Screen

The Home screen displays a schematic representation of the CDU 600, showing

- Essential temperatures
- Pressures
- Flows for both primary and secondary circuits
- Product code identification
- IP addresses
- Installed software version
- Date/time

See **Figure 4.1** on the next page.

Press or tap the Menu icon in the bottom right hand corner to display the main Menu screen.

Figure 4.1 Control System Home Screen

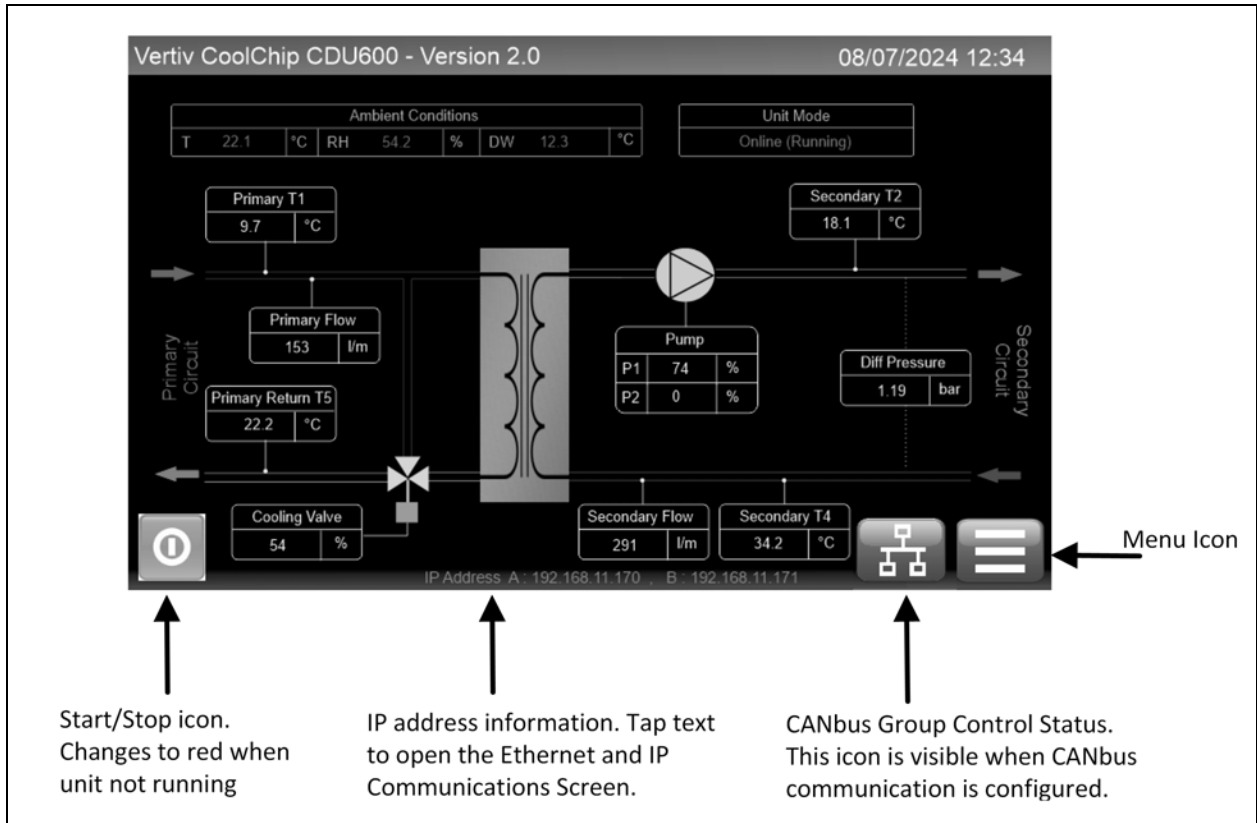

4.2.2 Main Menu

The Main Menu screen displays submenus for an increased level of information and modification of some parameters.

NOTE: Some submenus may not be visible if the user has not logged in. Visibility will also depend on the login access level used.

The touchscreen display is intuitive and easily navigable.

The touchscreen display has been designed to be intuitive and for easy navigation. **Figure 4.2** on the facing page provides an explanation of the elements in the Main Menu screen.

Figure 4.2 Control System Main Menu

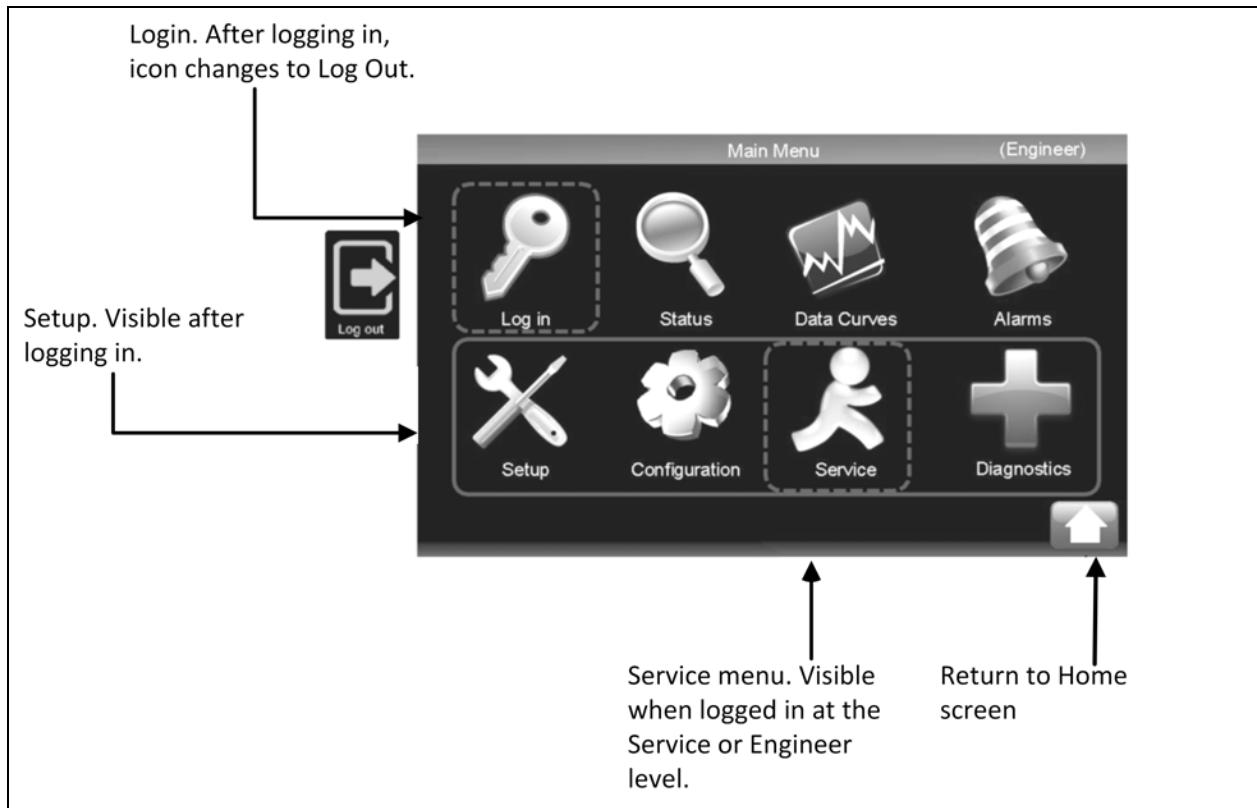

4.2.3 Status Screen

The Status screen displays information on the operation condition of the CoolChip CDU 600. This information is view only.

NOTE: Information is not given for options that have not been configured. For example, if the primary filter is not fitted, then PS3, PS4, and Filter Differential Pressure will show -101.

Figure 4.3 Control System Status Screen

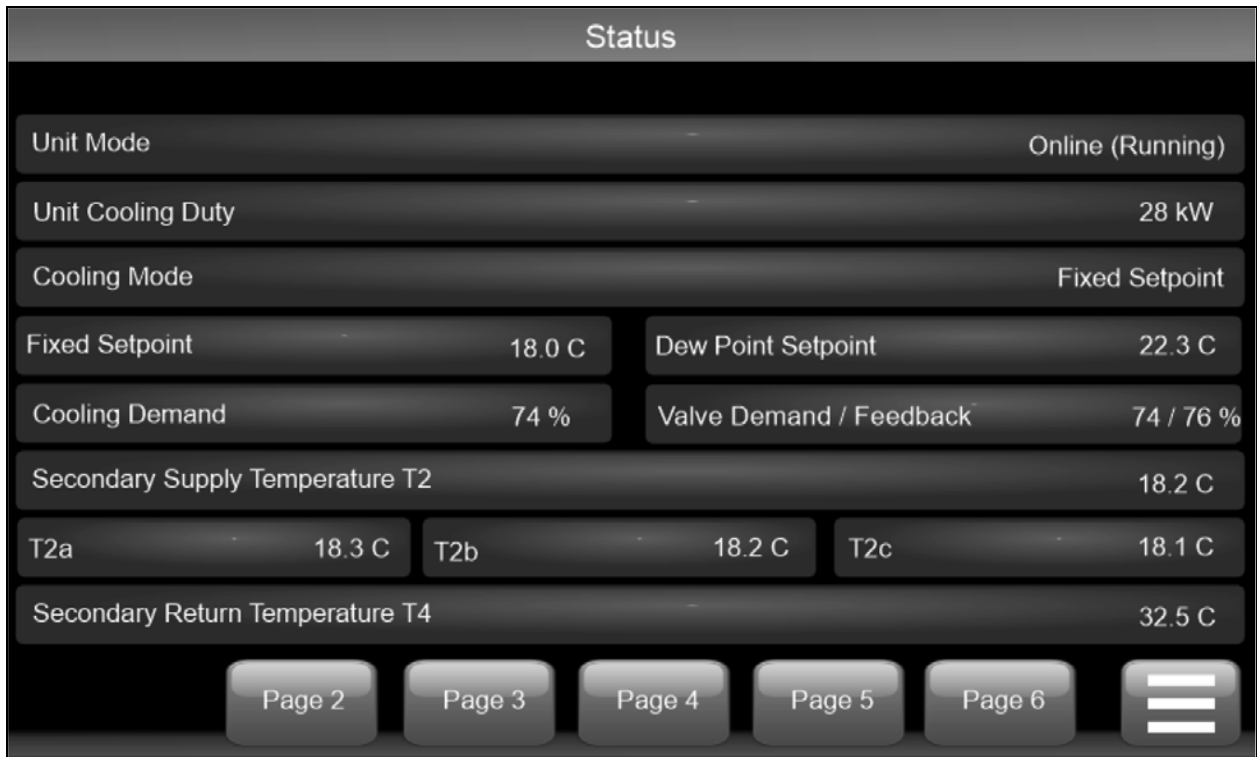

There are six information pages in the Status screen. To navigate between pages, click or tap the page number at the bottom of the screen.

Table 4.1 below through Table 4.7 on page 21 provides the details for the statuses listed on each page.

Table 4.1 Status Pages Details Page 1

Status	Description
Unit Mode	Options: <ul style="list-style-type: none"> Standby Online (running) Fault, Shutdown
Unit Cooling Duty	___ kW
Cooling Mode	Options <ul style="list-style-type: none"> Off Fixed Setpoint + DW Offset Fixed Setpoint
Fixed Setpoint	___ °C
Dew Point Setpoint	___ °C
Cooling Demand	___ %
Valve Demand Feedback	___/___ %
T2a	___ °C

Table 4.1 Status Pages Details Page 1 (continued)

Status	Description
T2b	___ °C
T2c	___ °C
Secondary Return Temperature T2	___ °C
Secondary Return Temperature T4	___ °C

Table 4.2 Status Pages Details Page 2

Status	Description
Primary Supply Temperature T1	___ °C
Primary Flow Rate	___ l/m
Primary Duty	___ kW
Primary Filter Inlet Pressure PS3	___ bar
Primary Filter Outlet Pressure PS4	___ bar
Primary Filter Differential Pressure PS3-PS4	___ bar
Ambient Temperature T3	___ °C
Ambient RH	___ %
Dew Point DW	___ °C

Table 4.3 Status Pages Details Page 3

Status	Description
Secondary Flow Rate	___ l/m
Secondary Return Pressure PS1	___ bar
Secondary Return Pressure PS1a	___ bar
Secondary Supply Pressure PS2	___ bar
Secondary Return Pressure PS1b	___ bar
Differential Pressure PS2-PS1	___ bar
Pump 1 Speed	___ %
Pump 2 Speed	___ %
Secondary Filter 1 Inlet Pressure PS5a	___ bar
Secondary Filter Inlet Pressure PS5b	___ bar
Secondary Filter 1 Differential Pressure	___ bar
Secondary Filter 2 Differential Pressure	___ bar

Table 4.4 Status Pages Details Page 4

Status	Description
Pump 1 Hours Run	__ Hrs
Pump 2 Hours Run	__ Hrs
Valve Runtime 0 to 25%	__ Hrs
Valve Runtime 26 to 50%	__ Hrs
Valve Runtime 51 to 75%	__ Hrs
Valve Runtime 76 to 100%	__ Hrs
Elapsed Minutes	__ Min
Controller Software Version	---
Unit Serial Number	---
Controller Hardware Version	---

Table 4.5 Status Pages Details Page 5

Status	Description
Pump 1 Comms Status	---
Pump 2 Comms Status	---
Pump 1 Mode	---
Pump 2 Mode	---
Pump 1 Frequency	__ Hz
Pump 2 Frequency	__ Hz
Pump 1 Voltage	__ V
Pump 2 Voltage	__ V
Pump 1 Current	__ A
Pump 2 Current	__ A
Pump 1 Power	__ kW
Pump 2 Power	__ kW
Pump 1 Heat Sink Temperature	__ °C
Pump 2 Heat Sink Temperature	__ °C
Pump 1 Last Fault Code	---
Pump 2 Last Fault Code	---

Table 4.6 Status Pages Details Page 6

CDU	Mode	DP Bar	Flow Rate l/m	Pump Speed P1	Pump Speee P2	T2 °C	Cooling Demand %	Alarm	Lead
1	Standby/Online	0.00	0	0	0.0	0	0	0	0
2	Standby/Online	0.00	0	0	0.0	0	0	0	0
3	Standby/Online	0.00	0	0	0.0	0	0	0	0
4	Standby/Online	0.00	0	0	0.0	0	0	0	0
5	Standby/Online	0.00	0	0	0.0	0	0	0	0
6	Standby/Online	0.00	0	0	0.0	0	0	0	0
7	Standby/Online	0.00	0	0	0.0	0	0	0	0
8	Standby/Online	0.00	0	0	0.0	0	0	0	0

Table 4.7 Status Pages Details Page 6 (Additional)

Status	Description
Average System DP	___ bar
Total System Flow Rate	___ l/m

NOTE: Page 6 is a quick reference for when multiple units are connected on a network using Group Control.

4.2.4 Data Curves Screen (Real Time Update)

The Data Curves screen shows a graphic representation of Cooling (Control Valve) Demand and Secondary Supply Temperature T2.

- Red traces cooling (Control Valve)
- Yellow traces Secondary Temperature Supply T2

Both update in real time, time span of display is 3 minutes.

Figure 4.4 Control System Data Curves Screen

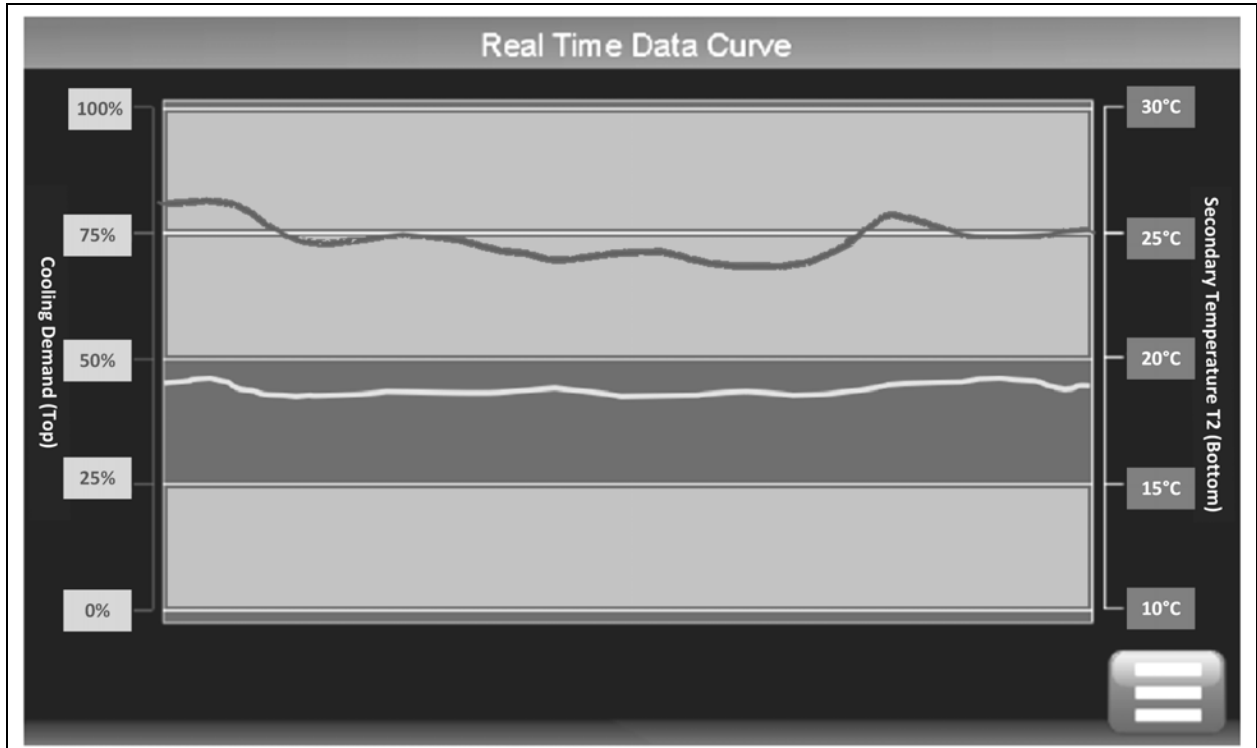

4.2.5 Alarm Screen

The Alarm screen is used to view new or active alarms and to acknowledge these events. Refer to **Table 4.41** on page 52 for a full list of alarms and further information.

Figure 4.5 Control System Alarms Screen



4.2.6 Login Screen

The Login screen provides further access to information and the ability to adjust various parameters and settings when logged in at the Service or Engineer level.

Table 4.8 Login Screen Access

User Level	Code	Description
User Level 1	No access code.	Provides access to Login, Status, Data Curves, and Alarm pages.
1234	User Level 2	Provides read only access to Setup, Configuration, and Diagnostic menus.
XXXX	Service Level	Provides full read only access to everything and write access to select configuration and service features.
XXXX	Engineer Level	Full read/write access to all features.

Figure 4.6 Control System Login Screen



Login codes are available upon request from Vertiv. Entering an invalid code will result in an Access Denied message.

After you are logged in, the Logout icon will replace the Login icon. See **Figure 4.2** on page 17.

4.2.7 Setup Screen

The Setup screen is visible after logging in. Normally, you will not require to use the Setup screen because items modified here are set at the factory or during commissioning. There may be times you may need to make adjustments following a site upgrade.

NOTE: Information available via the Factory Configuration option can be viewed with the Service and Engineer access codes. To make changes to items under Factory Configuration requires a special code.

Figure 4.7 Setup Screen

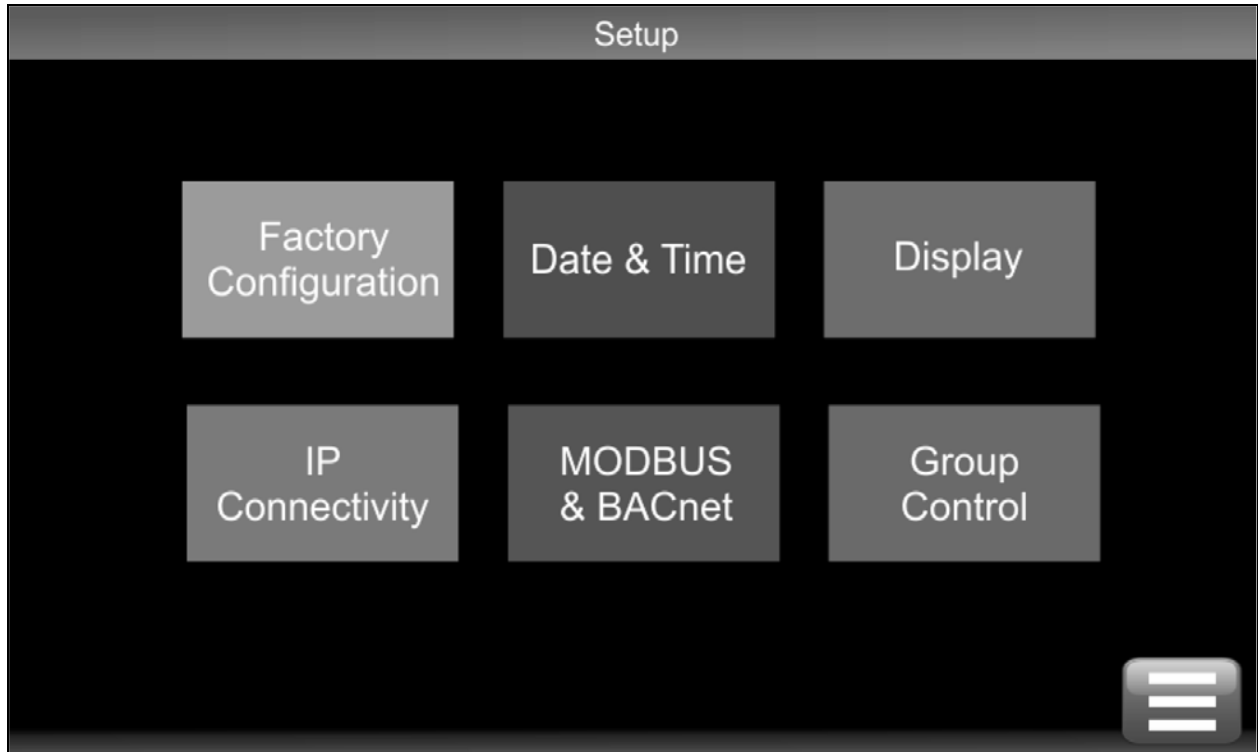

Table 4.9 Setup Factory Configuration

ID	Title	Description	Range
P001	Redundant Pumps	Select according to unit build	No, Yes
P002	Primary Filter	Select according to unit build	No, Yes
P003	Primary Flow Meter	Select according to unit build	No, Yes
P004	Secondary Filter	Select according to unit build	No, Yes
P005	RH&T Sensor Type	Select according to unit build	No, Yes
P006	Secondary Fluid Quality Instrumentation	Select according to unit build	No, Yes
P007	Single Valve	Select according to build	No, Yes
	Unit Serial Number	Select according to unit build	

Table 4.10 Setup Date and Time

ID	Title	Description	Default	Range	Unit
	Date	Adjust Date	—	dd/mm/y9y	—
P021	Date Format	Select preferred format	dd/mm/yyyy	dd/mm/yyyy mm/dd/yyyy yyyy/mm/dd	—
	Time	Adjust time (24 hour clock)	—	hh:mm:ss	—
P022	Daylight Saving	Adjust according to location	None	None Europe/UK N. America Australia	—
P023	NTP Synchronization	Select if NTP Synchronization is required or not.	Disabled	Disabled Enabled-Port A Enabled-Port B	—
P024	NTP Server IP Address	IP address of the NTP Server	0.0.0.0	Configurable	—
P025	Time Zone Offset	Select according to location	0.0	-12.0 to +12.0	hrs
P026	NTP Sync Interval	Interval between NTP synchronizations	23	1 to 168	hrs

Table 4.11 Setup Display

ID	Title	Description	Default	Range	Unit
P030	Screen Saver/Logout Period	Elapsed time before screen saver launches or display auto logs out	30	0 to 60	min
P031	Backlight Period	Elapsed time before screen dims	10	1 to 60	min
P032	Temperature Units	Select required temperature display units	°C	°C, °F	—
P033	Pressure Units	Select required pressure display units	bar	bar, psi	—
P034	Flow Rate Units	Select required flow rate display units	l/m	l/m, g/m	—

Table 4.12 Setup IP Connectivity

ID	Title	Description	Default	Range	Unit
P040	Interface A Enabled	Set to active or not. See Table 4.13 on the facing page for submenu details.	Enabled	Enable Disable	—
P041	Interface B Enabled	Set to active or not. See Table 4.14 on the facing page for submenu details.	Enabled	Enable Disable	—

Table 4.13 Setup IP Connectivity—Interface A Submenu

ID	Title	Description	Default	Range	Unit
P050	MAC Address	View MAC address	-----	Read only	—
P051	DHCP	Select as required	Disabled	Enable Disable	—
P052	IP Address	Set IP address	192.168.11.170	Configurable	—
P053	Subnet Mask	Set Subnet mask	255.255.255.0	Configurable	—
P054	Default Gateway	Set Gateway address	0.0.0.0	Configurable	—
P055	Preferred DNS Server	Set DNS address	0.0.0.0	Configurable	—
P056	Alternative DNS Server	Set DNS address	0.0.0.0	Configurable	—

Table 4.14 Setup IP Connectivity—Interface B Submenu

ID	Title	Description	Default	Range	Unit
P060	MAC Address	View MAC address	-----	Read only	—
P061	DHCP	Select as required	Disabled	Enable Disable	—
P062	IP Address	Set IP address	192.168.11.170	Configurable	—
P063	Subnet Mask	Set Subnet mask	255.255.255.0	Configurable	—
P064	Default Gateway	Set Gateway address	0.0.0.0	Configurable	—
P065	Preferred DNS Server	Set DNS address	0.0.0.0	Configurable	—
P066	Alternative DNS Server	Set DNS address	0.0.0.0	Configurable	—

Refer to the Vertiv IP Communications Guide for further information on TCP/IP and Ethernet services, 10043575MAN_ENG, Rev B.

Table 4.15 Setup Modbus

ID	Title	Description	Default	Range	Unit
P070	Modbus Address	Set required address	1	1 to 247	—
P071	Baud Rate	Set the required RS485 baud rate	9600		
P072	Coil Write Access	Set write access privileges	No	No, Yes	—
P073	Serial Protocol	Set required RS485 serial protocol	MODBUS RTU	MODBUS RTU BACnet MSTP	--

Table 4.16 Setup BACnet

ID	Title	Description	Default	Range	Unit
P074	Protocol	Set required protocol type (and physical communication port)	Diabled	Disabled, IP—Port A IP—Port B MSTP	—
P075	Instance Number	Set Device Instance Number	Based on Serial No.	0 - 4194301	—
P076	MSTP MAC Address	Set MSTP MAC Address	1	1 - 127	—
P077	MSTP Max Masters	Set MSTP Max Masters	127	1 - 127	—
P078	MSTP Info Frames	Set MSTP number of Info Frames	1	1 - 100	—
P079	Units	Set Present Value Units	SI	SI Imperial	—

Table 4.17 Setup Group Control

ID	Title	Description	Default	Range	Unit
P081	CDU Address	CDU Group Address	1	1 to 8	—
P082	Number of CDUs in Group	Number of CDUs in Group	1	1 to 8	—
P083	Number of Run CDUs	Number of run CDUs	1	1 to 8	—
P084	Failover Scheme	0 = Pump failover disabled 1 = Pump failover mode is enabled. If a pump fails, the unit switches to the redundant pump in the unit itself before it goes to another unit.	0	0, 1	—
P085	Rotation Frequency	Unit rotation frequency	Weekly	Weekly Monthly Never	—
P086	Rotation Day of Week	Rotation day	Mon.	Sun. to Sat.	—
P087	Rotation Time of Day - Hours	Rotation hours	11	00 to 23	hrs
P088	Rotation Time of Day - Minutes	Rotation minutes	00	00 to 59	mins
P089	Unit Receive Timeout Period	Set require unit receive timeout	3000	50 to 10000	msecs
P090	Unit Transmit Period	Set required unit transmit period	100	20 to 1000	msecs
P093	Baud Rate Index	Baud rate	2	0 to 3	—
P094	Group Control DP Average	0 = running CDUs only, 1 = all CDUs	0	0 to 1	—

4.2.8 Configuration Screen

The Configuration screen is used to set specific parameters and control functions.

Figure 4.8 Control System Configuration Screen

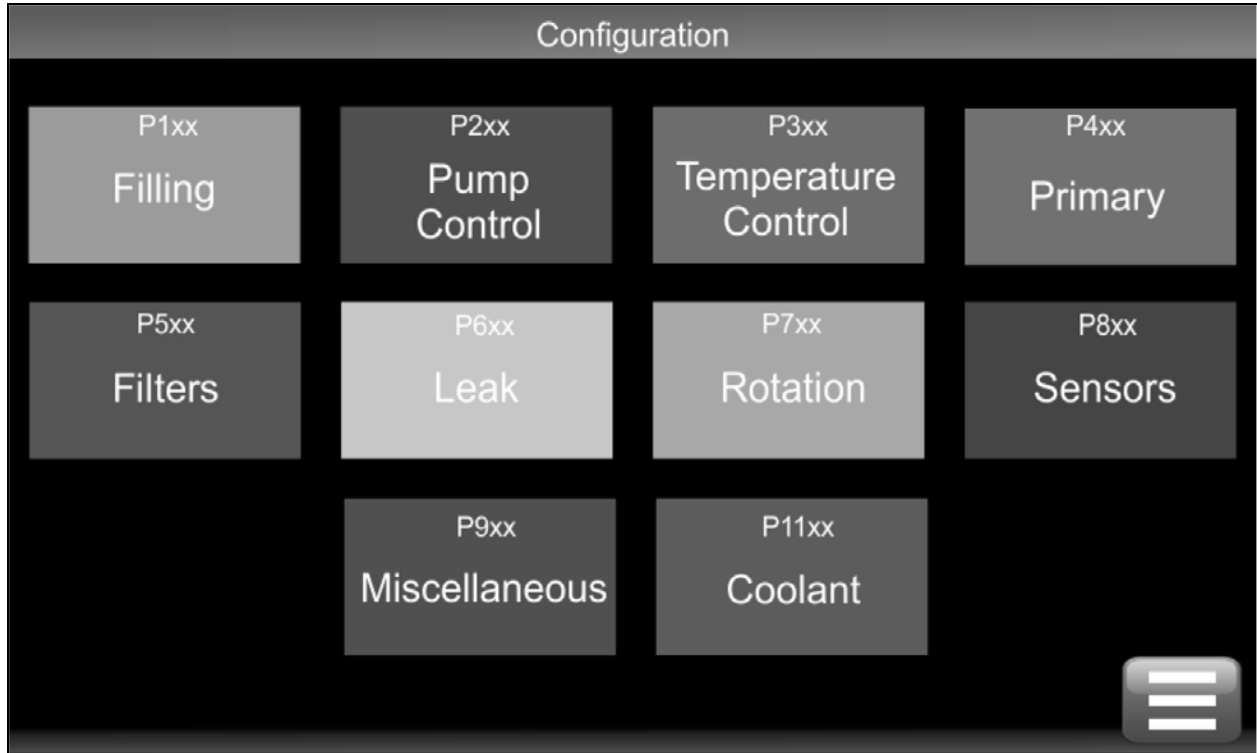

NOTE: Parameter IDs shown in *italics* below are only accessible with the Engineer login code.

Table 4.18 Configuration—Filling

ID	Title	Description	Default	Range	Unit
P101	Fill Pressure	Start threshold for fill pump	0.8	0.3 TO 1.0	bar
P102	Fill Hysteresis	Stop hysteresis for fill pump	0.2	0.1 to 0.5	bar
P103	Fill Pump Run Period	Time for level sensor to make, or fill pressure to be satisfied, prior to alarm (when unit is online)	1	1 to 15	min
P104	Level Sensor Delay	Level sensor response time, prior to alarm	1	1 to 6	secs
P105	Fill Start Delay Period	Delay prior to pump start after initiate signal	10	1 to 600	secs
P106	Fill Warning Delay Period	Delay prior to Check Make Up alarm activated	5	0 to 50	secs
P107	Group Fill	Group Fill 0 = No, 1 = Yes	0	0—1	—

Table 4.18 Configuration—Filling (continued)

ID	Title	Description	Default	Range	Unit
		All CDUs fill when any one CDU activates fill pump			
P108	Delta Load	Drop in Load	0	0 to 500	kW
P109	Delta Load Period	Drop in Load Period	60	0 to 90	secs

Table 4.19 Configuration—Pump Control

ID	Title	Description	Default	Range	Unit
P201	Control Type	Pump speed flow or DP controlled	Flow	Flow or DP	—
P202	Flow Setpoint	Set the required secondary flow rate	100	50 to 500	l/m
P203	Differential Pressure Setpoint	Set the required secondary DP	0.3	0.1 to 4.0	bar
P204	Low Flow %	Low flow alarm threshold (% of flow setpoint)	90	10 to 95	%
P205	Low DP %	Low DP alarm threshold (% of DP setpoint)	90	10 to 95	%
P206	Low Flow/DP Delay	Time delay prior to low flow/DP alarm	100	1 to 300	secs
P207	Minimum Pump Speed	Minimum pump speed	15	10 to 70	%
P208	Twin Pump Control	Set to twin or single pump mode	No	No, Yes	—
P209	Maximum Pump Speed	Set maximum pump running speed	100	25 to 100	%
P210	Pump Changeover Delay	Pump changeover period (change from P1 to P2 or P2 to P1)	250	50 to 500	msec
P211	Over Pressure Setpoint	Maximum system pressure, prior to alarm (dependant on PRV rating)	PRV setting less 10%	2.0 to 7.0	bar
P212	Over Pressure Action	Alarm only or alarm + shutdown	Alarm	Alarm or Alarm + S/D	—
<i>P213</i>	Startup Speed	Initial pump start fixed speed (0 = Auto)	0	0 to 100	%
<i>P214</i>	Startup Period	Initial start speed hold period, prior control loop taking over	0	0 to 100	secs
<i>P215</i>	Loop Refresh Period	Scan period for pump speed control loop	10	1 to 120	secs
<i>P216</i>	Maximum Control Pressure	Maximum pump speed control loop pressure	4.0	1.0 to 8.0	bar
<i>P217</i>	Failover Speed Reduction	Reduction in pump speed when moving to twin pump	0	0 to 50	%

Table 4.19 Configuration—Pump Control (continued)

ID	Title	Description	Default	Range	Unit
		mode following group failover			
P218	Fault Reset Attempts	Set number of inverter fault reset attempts	2	0 to 10	—
P219	Fault Reset Period	Set fault reset attempts period	600	60 to 3600	secs
P220	Twin Maximum Pump Speed	Set maximum pump running speed when operating in twin pump mode	100	25 to 100	%

Table 4.20 Configuration—Temperature Control

ID	Title	Description	Default	Range	Unit
P301	Temperature Setpoint	Set required secondary temperature setpoint	18.0	10.0 to 55.0	°C
P302	Control Mode	Select from Fixed Setpoint or Fixed Setpoint with Dew Point Offset	FSDO	FS FSDO	—
P303	Dew Point Offset	Minimum offset of setpoint from dew point temp.	3.0	1.0 to 5.0	°C
P304	Sec. Low Temp Diff.	Low temp alarm offset below setpoint	2.0	1.0 to 10.0	°C
P305	Sec. High Temp Diff	High temp alarm offset above setpoint	2.0	1.0 to 10.0	°C
P306	Sec. Temp Reset Hysteresis	Low/high temp. alarm reset point	1.0	.05 to 5.0	°C
<i>P307</i>	PID – Control Period	Scan period for control valve positioning	1	1 to 30	secs
<i>P308</i>	PID – Proportional Band	Proportional band	12.0	1.0 to 25.0	°C
<i>P309</i>	PID – Integral Reset	Integral reset time	18	0 to 999	secs
<i>P310</i>	PID – Derivative	Derivative reset time	5	0 to 999	secs
P311	Demand/Actual Error	Cooling valve demand to feedback error for alarm	10	0 to 50	%
P312	Valve Check Period	Scan period for cooling valve position monitoring	15	1 to 120	mins
<i>P313</i>	Valve Runtime	Cooling valve motor run time for control loop	40	10 to 80	secs
P314	Valve Minimum Position	Cooling valve minimum position	0	0 TO 80	%
P315	Valve Maximum Position	Cooling valve maximum position	100	40 to 100	%

Table 4.21 Configuration—Primary

ID	Title	Description	Default	Range	Unit
P401	Pri. Flow Delay	Time delay prior to low flow alarm	5	1 to 120	mins
P402	Pri. Low Temp Setpoint	Low temp alarm threshold	4	2 to 40	°C
P403	Pri. High Temp Setpoint	High temp alarm threshold	11	6 to 50	°C
P404	Pri. Temp Reset Hysteresis	Low/high alarm reset from threshold	1	0.5 to 5.0	°C

Table 4.22 Configuration—Filters

ID	Title	Description	Default	Range	Unit
P501	Pri. Filter Dirty Setpoint	Differential pressure alarm threshold for filter dirty	0.6	0.2 to 2.0	bar
P502	Pri. Filter Dirty Hysteresis	Alarm reset from threshold	0.2	0.1 to 0.5	bar
P503	Pri. Filter Dirty Delay Period	Time delay prior to alarm	60	10 to 600	secs
P504	Sec. Filter Dirty Setpoint	Differential pressure alarm threshold for filter dirty	0.2	0.2 to 1.0	bar
P505	Sec. Filter Dirty Hysteresis	Alarm reset from threshold	0.1	0.1 to 0.5	bar
P506	Sec. Filter Dirty Delay Period	Time delay prior to alarm	60	10 to 600	secs

Table 4.23 Configuration—Leak Detection

ID	Title	Description	Default	Range	Unit
P601	Leak Detection – Flood Tray	Alarm only, or alarm + shutdown	Alarm+S/D	Alarm or Alarm+S/D	—
P602	Leak Detection – Underfloor	Alarm only, or alarm + shutdown	Alarm+S/D	Alarm or Alarm+S/D	—
P603	Underfloor Threshold	Set sensitivity of leak tape	50	1 to 65	kohm
P604	Underfloor Delay Period	Time delay prior to alarm	10	5 to 60	secs

Table 4.24 Configuration—Rotation

ID	Title	Description	Default	Range	Unit
P701	Frequency	Frequency of pump changeover	Weekly	Never Weekly Monthly	—
P702	Day of Week	Set day of changeover	Monday	Sunday to Saturday	—
P703	Time of Day - Hours	Time of changeover (hour)	10	00 to 23	hrs
P704	Time of Day - Minutes	Time of changeover (min)	00	00 to 59	mins

Table 4.25 Configuration—Sensors

ID	Title	Description	Default	Range	Unit
P801	Secondary T2 Temperature Differential	Alarm threshold T2a/b/c temperature differential	1	0.1 to 10	°C
P802	Secondary T2 Period	Time delay before T2a/b/c differential alarm	30	0 to 120	secs
P803	Secondary PS1 Pressure Differential	Alarm threshold PS1a-PS1b pressure differential	0.2	0.1 to 1.0	bar
P804	Secondary PS1 Period	Time delay before PS1a-PS1b differential alarm	30	0 to 120	l/m
P805	Secondary Flow Sensor Full Scale	Adjust full scale (20mA) reading when external external flow meter fitted.	646	100 to 1000	l/m
P809	PS1a Scaling	Set measurement range. ¹	2	0 to 4	—
P810	PS1b Scaling	Set measurement range. ¹	2	0 to 4	—
P811	PS2 Scaling	Set measurement range. ¹	2	0 to 4	—
P812	PS3 Scaling	Set measurement range. ¹	2	0 to 4	—
P813	PS4 Scaling	Set measurement range. ¹	2	0 to 4	—
P814	PS5a Scaling	Set measurement range. ¹	2	0 to 4	—
P815	PS5b Scaling	Set measurement range. ¹	2	0 to 4	—

¹ 0 = 0 to 30 bar, 1 = 0 to 15bar, 2 = -1 to 8 bar, 3 = 0 to 6.89bar, 4 = -0.69 to +6.89 bar.

Table 4.26 Configuration—Miscellaneous

ID	Title	Description	Default	Range	Unit
P901	Manual Override Period	Time delay before controls revert to Auto mode	15	0 to 120	mins
P902	Alarm Delay	Alarm suppression on startup	20	1 to 120	mins
P903	Alarm Relays	Extended alarm relay operation mode	N/O	N/O N/C	—
P904	Post Power Failure Options	Action to be taken following a power failure once power is restored	Run	Run Standby	—
P905	Data Logging Interval	Interval between data being logged to SD card (0 = 60s, 1 = 30s, 2 = 10s, 3 = 5s)	0	0, 1, 2, 3	—
P906	Remote Start/Stop Options	Closed or Open circuit to run unit	N/O	N/O N/C	—
P907	Number of Alarm Outputs	Number of relays used for extended alarms	2	1 or 2	—
P908	Display Lockout	Lockout following failed logins	No	No Yes	—

Table 4.27 Configuration—Coolant

ID	Title	Description	Default	Range	Unit
P1101	Secondary Loop Coolant Type	Set secondary loop coolant type	Water	Water PG25	—
P1102	Primary Loop Coolant Type	Set primary loop coolant type ¹	Water	Water PG25	—

¹ Selection of PG25 equates to nominal 25% propylene glycol content.

4.2.9 Service Screen

The Service screen is used to set some parameters and to assist during commissioning. This screen is accessible only with the Service and Engineer logon codes.

Figure 4.9 Control System Service Screen

Table 4.28 Service—Fill Pump Request

Option	Description
 <p>Switch Fill Pump P3</p> <p>Cancel Off ON</p> <p>1. Confirm that the filling unit is connected</p> <p>2. Switch Fill Pump P4</p> <p>Cancel Off ON</p>	<p>The fill pump function is used only during commissioning. This allows the fill pumps to run without any time limit. Fill pump will switch OFF automatically when the unit reaches required static pressure or when reservoir tank is full.</p>

Table 4.29 Service—Rotation

Option	Description
 <p>Force Rotation</p> <p>Cancel</p> <p>Pump</p> <p>Group</p>	<p>This is used to force a pump changeover at an unscheduled time or to force a unit changeover when Group Control is active.</p>

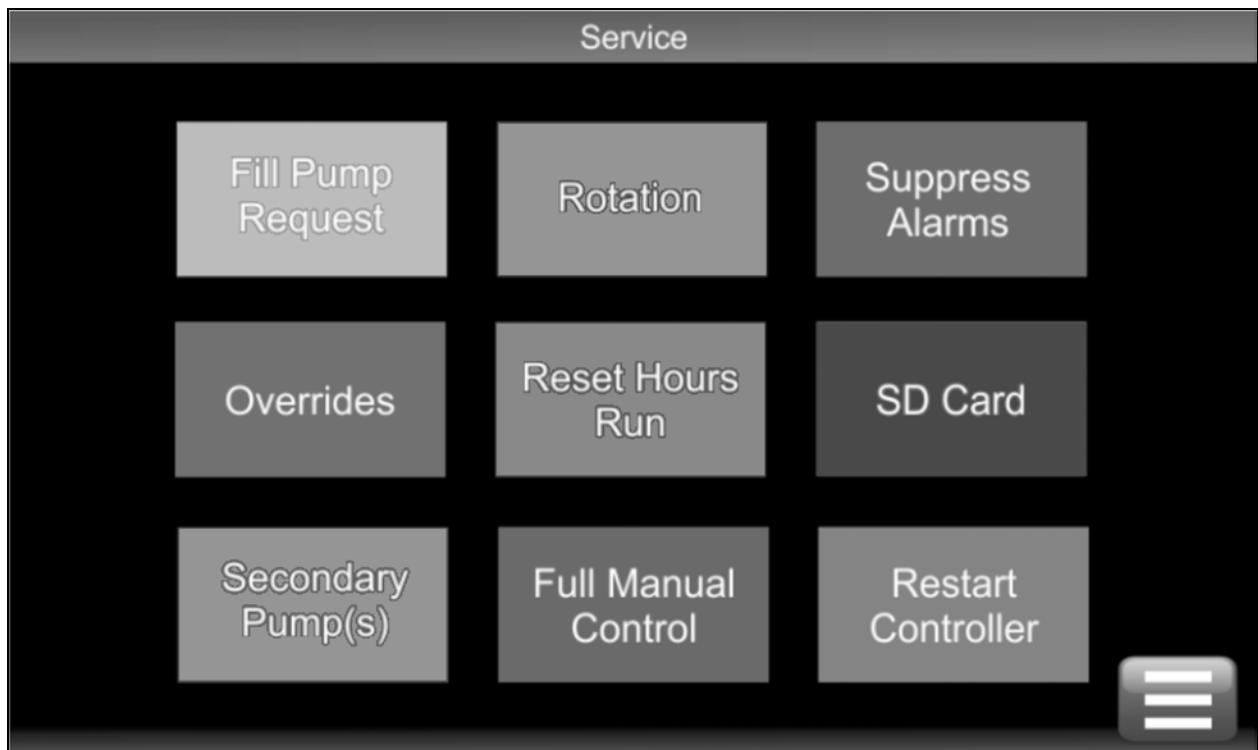
Table 4.30 Service—Suppress Alarms

Option	Description
 <p>Suppress Alarms</p> <p>Cancel OK</p>	<p>Resets the alarm delay timer to stop nuisance alarms breaking through during manual operation. Alarm delay timer is normally activated during startup.</p>

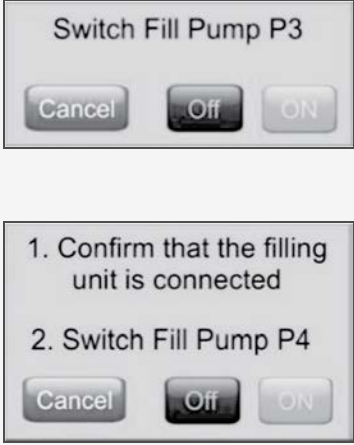
Table 4.31 Service—Overrides

ID	Title	Description	Default	Range	Unit
S101	Pump 1 Speed	Set pump 1 inverter speed. 0% = no override.	0	0 to 100	%
S102	Pump 2 Speed	Set pump 2 inverter speed. 0% = no override.	0	0 to 100	%
S103	Cooling Valve	Set cooling valve position. 0% = no override.	0	0 to 100	%
S104	Fill Pump P3	Switch fill pump on	Auto	Auto—Man.	—
S105	Alarm	Simulate fault on customer alarm relay	Auto	Auto—Man.	—

Overrides allows manual control of some functions of the unit for a limited time period while running an automatic model for troubleshooting. See **SL-07625 CoolChip CDU 600 Installation and Commissioning** for additional information. If an operator issues an override while the CDU is not in automatic mode, the override is ignored and the value will be automatically set back to default.

Table 4.32 Service—Reset Hours Run

ID	Title	Description	Default	Range	Unit
S201	Pump 1 Run Hours	Set pump 1 run hours to zero	—	—	hrs
S202	Pump 2 Run Hours	Set pump 2 run hours to zero	—	—	hrs
S203	Cooling Valve Run Hours	Set cooling valve run hours to zero	—	—	hrs

Table 4.33 Service—SD Card

Option	Description
	Use this dialog to control access to the SD card. Select Unmount to allow safe removal of the SD card. Select Mount following re-insertion of the SD card.

Table 4.34 Service--Full Control Manual

ID	Title	Description	Default	Range	Unit
S301	Full Manual Control	Allows full manual control of all functions	Disabled	Disabled Enabled	—
S302	Pump 1 Speed	Set pump 1 inverter speed	0	0 to 100	%
S303	Pump 2 Speed	Set pump 2 inverter speed	0	0 to 100	%
S304	Cooling Valve	Set control valve position	0	0 to 100	%

Table 4.34 Service--Full Control Manual (continued)

ID	Title	Description	Default	Range	Unit
S305	Fill Pump P3	Switch fill pump on	Off	Off—On	—
S306	Alarm	Simulate fault on customer alarm relay	Off	Off—On	—
S307	Fill Pump P4	Switch fill pump on	Off	Off—On	—

Full Manual control provides manual control of all functions of the unit for a limited time period. Selection causes the unit to switch OFF with the controller in dumb mode. See SL-7625 CoolChip CDU 600 Installation and Commissioning for more information. Manual override requests are honored only if S301 is set to Enabled. Otherwise, commands are automatically reset to default.

Table 4.35 Service—Restart Controller

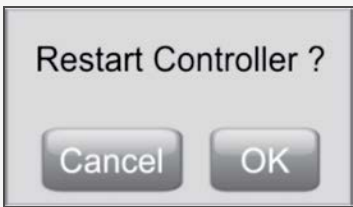
Option	Description
	Use this dialog to force a restart of the controller and touchscreen display. (Available on firmware release 3.5 and above.)

4.2.10 Diagnostics Screen

The Diagnostics screen provides raw information and conversion factors for the status of all Universal Inputs, Resistive Inputs, Digital Inputs, Digital Outputs, and Analogue Outputs.

Figure 4.10 Control System Diagnostics Screen

I/O Diagnostic - Universal Inputs 1 to 8				
		ADC Value	Electrical	Processed
UI01	Secondary Return Pressure PS1a	15501	4.73 mA	1.36 bar
UI02	Secondary Return Pressure PS1b	15552	4.75 mA	1.38 bar
UI03	Secondary Supply Pressure PS2a	21201	5.21 mA	2.01 bar
UI04	Secondary Supply Pressure PS2b	41021	6.89 mA	2.02 bar
UI05	Primary Filter Inlet/Outlet Pressure PS3/PS4	37124	6.87 mA	3.35 bar
UI06	Secondary Filter Inlet Pressure PS5a	65496	4.93 mA	2.01 bar
UI07	Secondary Filter Inlet Pressure PS5b	15116	4.99 mA	2.13 bar
UI08	ATS Status	0	0 ohms	A, B Avl

Table 4.36 I/O Diagnostics—Universal Inputs 1 to 8

ID	Description	ADC Value	Electrical	Processed
UI01	Secondary Return Pressure PS1a	0	0.00 mA	0.00 bar
UI02	Secondary Return Pressure PS1b	0	0.00 mA	0.00 bar
UI03	Secondary Supply Pressure PS2a	0	0.00 mA	0.00 bar
UI04	Secondary Supply Pressure PS2b	0	0.00 mA	0.00 bar
UI05	Primary Filter Inlet/Outlet Pressure PS3/PS4	0	0.00 mA	0.00 bar
UI06	Secondary Filter Inlet Pressure PS5a	0	0.00 mA	0.00 bar
UI07	Secondary Filter Inlet Pressure PS5b	0	0.00 mA	0.00 bar
UI08	ATS Status	0	0.00 ohms	No ATS

Table 4.37 I/O Diagnostics—Universal Inputs 9 to 16

ID	Description	ADC Value	Electrical	Processed
UI09	Primary Supply Temperature T1	0	0.00 ohms	0.00 °C
UI10	Secondary Return Temperature T4	0	0.00 ohms	0.00 °C
UI11	Primary Flow Rate	0	0.00 mA	0 l/m
UI12	Secondary Flow Rate	0	0.00 mA	0 l/m

Table 4.37 I/O Diagnostics—Universal Inputs 9 to 16 (continued)

ID	Description	ADC Value	Electrical	Processed
UI13	Ambient Sensor – RH	0	0.00 mA	0 %
UI14	Ambient Sensor – Temperature T3	0	0.00 ohms	0.00 °C
UI15	Primary Return Temp. T5	0	0.00 ohms	0.00 °C
UI16	Control Valve Feedback	0	0.00 V	0.00%

Table 4.38 I/O Diagnostics—Resistive Inputs 1 to 4 and Universal Inputs 17 to 19

ID	Description	ADC Value	Electrical	Processed
RI01	Underfloor Leak Tape	0	0 ohms	0
RI02	Secondary Flow Temperature T2a	0	0 ohms	0.00 °C
RI03	Secondary Flow Temperature T2b	0	0 ohms	0.00 °C
RI04	Secondary Flow Temperature T2c	0	0 ohms	0.00 °C
U17	Secondary Fluid Quality -- Turbidity	0	0.00 mA	0.0 NTU
U18	Secondary Fluid Quality -- PH	0	0.00 mA	0.00 PH
U19	Secondary Fluid Quality -- Conductivity	0	0.00 mA	0.0 S/cm

Table 4.39 I/O Diagnostics—Digital Inputs 1 to 6

ID	Description	State
DI01	Flood Tray Level Switch	Open
DI02	Fluid Level Sensor #1	Open
DI03	Fluid Level Sensor #2	Open
DI04	Reservoir Tank Level Sensor - High	Open
DI05	Reservoir Tank Level Sensor - Low	Open
DI06	Reservoir Tank Level Sensor – Very Low	Open

Table 4.40 I/O Diagnostics—Digital and Analogue Outputs

ID	Description	State
DO01	Unit Fill Pump P3	OFF
DO03	PS3/PS4 Select	OFF
DO05	Reservoir Tank Fill Pump P4	OFF
DO06	Extended Alarm	OFF
AO01	Cooling Valve	%

4.2.11 Group Control Status Screen

The Group Control Status screen provides that status information of other CDUs connected to the CANbus network. Access the Group Control Status Screen from page 6 of the Control System Status screen.

Figure 4.11 Group Control Status Screen

Group Control Status									
CDU	Mode	DP bar	Flow Rate l/m	Pump Speed %		Temp T2 °C	Cooling Demand %	Alarm	Lead
				P1	P2				
1	Online (Running)	1.89	230	55	0	18.2	67	0	1
2	Online (Running)	1.92	235	0	55	18.1	73	0	0
3	Online (Running)	1.97	210	55	0	18.0	59	0	0
4	Group Standby	1.76	0	0	0	18.8	0	0	0
5	Shutdown	1.23	0	0	0	19.2	0	1	0
6	Not In Group	0	0	0	0	0	0	0	0
7	Not In Group	0	0	0	0	0	0	0	0
8	Not In Group	0	0	0	0	0	0	0	0

Average System DP	1.93 bar	Total System Flow Rate	675 l/m
-------------------	----------	------------------------	---------

4.2.12 Ethernet and IP Communication Status Screen

The Ethernet and IP Communication Status screen provides information on Ethernet link, speed, and duplex status along with IPv4 address details and message counts for Ethernet interface A and B. See **Figure 4.12** on the facing page. Access this screen from the home page by selecting the IP address as shown in **Figure 4.2** on page 17.

Figure 4.12 Ethernet and IP Communication Status

Ethernet & IP Communication Status			
Ethernet Interface A	Link State	<input checked="" type="checkbox"/>	Speed 100 MBS Duplex Full
	Last Up	12/12/2020 7:46:23	Last Down 11/10/2020 23:01:02
IPv4	192.168.11.170	Rx 3478	Tx 65432
Ethernet Interface B	Link State	<input type="checkbox"/>	Speed 0 MBS Duplex -
	Last Up	11/10/2020 7:46:23	Last Down 11/10/2020 23:02:02
IPv4	- - -	Rx 10	Tx 2



4.2.13 Calibration Screen

To calibrate the touchscreen, press the screen 20 times within a 20 second interval. The Calibration screen will then open. Follow the on screen instructions to complete calibration.

Figure 4.13 Control System Calibration Screen



4.3 Automatic Operation

After commissioning, the unit is ready to run in automatic mode. Press the Start/Stop button on the Home screen (see **Figure 4.1** on page 16) and select the ON button.

Figure 4.14 Switch CDU Control System ON/OFF

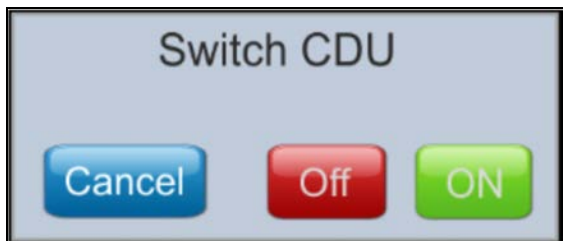

4.3.1 Primary Circuit Operation

The primary fluid temperature is monitored at the inlet to the CoolChip CDU 600 cabinet. The nominal cooling performance of the CDU has been calculated on a chilled water temperature between 4°C and 10°C (40°F and 50°F).

For the detailed view of Piping Schematic, refer to the [Submittal Drawings](#) on page 77.

- If the primary temperature falls below the default of 4°C (40°F), an A30—Primary Fluid Low Temp alarm is generated. This alarm remains present until the temperature rises above the default of 1°C (2°F) hysteresis.
- if the primary temperature rises above the default of 11°C (52°F), an A31—Primary Fluid High Temp alarm is generated. This alarm remains present until the temperature falls below the default of 1°C (2°F) reset hysteresis.

- The high and low temperature alarms are ignored for a default 20 minute period on startup to allow the system time to settle without generating nuisance alarms.

The temperature PID control loop is operational from when the Start/Stop button is pressed and the pump has ramped up to speed. If the secondary circuit temperature starts to rise above the setpoint, then the cooling valve starts to open to allow more primary cooling fluid through the heat exchanger. The cooling valve modulates from 0% (full bypass) to 100% (full flow through heat exchanger). The valve position can be monitored on the Home screen or page 2 of the Status screen. The demand signal to the valve is compared to a position feedback signal every 15 minutes (default) to check the healthy operation of the valve.

- If the feedback signal is more than 10% (default) of the demand signal, allowing for the drive time of the actuator to respond to load changes, then an A26—Valve Fault event is generated. The valve will continue to operate until fault is rectified.

The Cooling Valve is a drive open/drive close device and if the positioning signal is lost, it remains at the last known operating position. (Assuming no signal, valve closes at 0v.)

- If the differential pressure exceeds 0.6 bar (9 psi), then an A29—Primary Filter Dirty alarm is generated.

Primary flow rate is monitored with a calorimetric flow meter at the primary inlet to the CDU. The flow can be read on the Home screen or on page 2 of the Status screen.

IMPORTANT! The flow meter only reads the total primary flow through the CDU 600 unit. It does not monitor the flow rate through the heat exchanger.

- An A27—Primary Low Flow alarm is generated if
 - The A33—Secondary Fluid High Temperature alarm is active
 - The A31—Primary Fluid High Temperature alarm is not present
 - The demand to the operational cooling valve is at 100%
- An A28—Primary No Flow alarm can also be generated if
 - The A33—Secondary Fluid High Temperature event is active
 - There is also an A31—Primary Fluid High Temperature alarm is present
 - Demand to the operational cooling valve is at 100%

IMPORTANT! Flows below 17 l/m (4.5 gpm) are outside the range of the flow sensor and will not be displayed.

4.3.2 Secondary Circuit Operation

When the ON button is pressed, the icon on the Home screen changes from red to green. If the fluid level and status pressure are healthy, one or both pumps (depending upon configuration) start to increase in speed. Arrows are displayed on the Home screen for both primary and secondary circuits and the pump speed is shown as a percentage of maximum will be displayed. The inverter displays will also show the actual frequency output to the pump motors.

For the detailed view of Piping Schematic, refer to the [Submittal Drawings](#) on page 77.

Fluid Level

- If both fluid level sensors located on the pump inlet header do not signal sufficient fluid, then neither main pump P1 or P2 will run.
- If the fluid level sensors register no fluid for period of more than 1 second an A41—Level Sensor No Fluid Detected alarm is generated.
 - If the unit differential pressure or flow rate is still more than 50% of setpoint, then the unit continues to run.

- If the differential pressure or flow drops below 50% of setpoint, then the unit will stop and an A40—Insufficient Fluid alarm is generated. This is a latched alarm and it will be impossible to restart the unit until the event has been manually cleared.

The system pressure at the CDU inlet (PS1) is continuously monitored to ensure that the system is always pressurized. See 17

Static Pressure

- Once the unit is running, a low system pressure below the default 0.8 bar at PS1 will not stop the main pump from running, but will initialize the P3 fill pump. After a 10 second default delay, the PS1 pressure is raised to a default of 1.0 bar (15 psi) and the fill pump stops. If the reservoir tank very low level sensor is activated while fill pump P3 is running, an A51—Reservoir Tank Empty alarm is generated and fill pump P3 stops. This is a latched alarm and will need to be manually cleared, but will not stop the unit from running.
- If inlet pressure drops to 0.2 bar (3 psi) below fill pump activation threshold for more than 1 minute, an A39 System Low Pressure event is generated. The inlet pressure drop value is set at 0.2 bar (3 psi) and is non-adjustable. Time value for the below pump activation threshold is set at 1 minute and is non-adjustable.

The flow charts in 44 show the unit pressure/level monitoring and fill pump control during initial startup of the unit after commissioning (from a unit offline condition) and also during normal running (unit online).

Pump Control Logic

Pump flow/pressure performance (pump speed) is controlled through a differential pressure control loop.

If pumps are set up for run/standby operation, they operate on a duty sharing cycles during normal healthy running. By default, every 7 days, the operational pump ramps down to a stop and the standby pump starts and continues to operate for the next 7 days. Default changeover time is 10:00 a.m. on Monday and the complete changeover sequence takes approximately 0.25 seconds (default).

IMPORTANT! Each time that the unit is stopped and restarted, it selects the initial operating pump that has the lowest accrued run time hours.

DP Control

DP Control monitors the secondary differential pressure with sensors on the supply and return connections of the CDU. Upon startup, the control loop increases the pump speed in stages until the DP matches the DP setpoint.

The pump control loop has a default scan time of 10 seconds to avoid control oscillation.

- If Pump 1 fails to reach 90% (default) of the DP demand in 100 seconds (default time period), it is assumed there is a pump flow/pressure fault. Pump 1 ramps down to a stop and Pump 2 is initialized. At the same time, an A22-P1 Inverter Low Flow alarm is generated.
- If Pump 2 fails to reach 90% of the set DP demand within the time limit, an A25-P2 Inverter Low Flow alarm is generated.
- The above assumes that Pump 1 is the initial operating pump. The reverse would apply if Pump 2 was the operating pump.

Figure 4.15 Fill Pressure and Level Flow Chart (Initial Start)

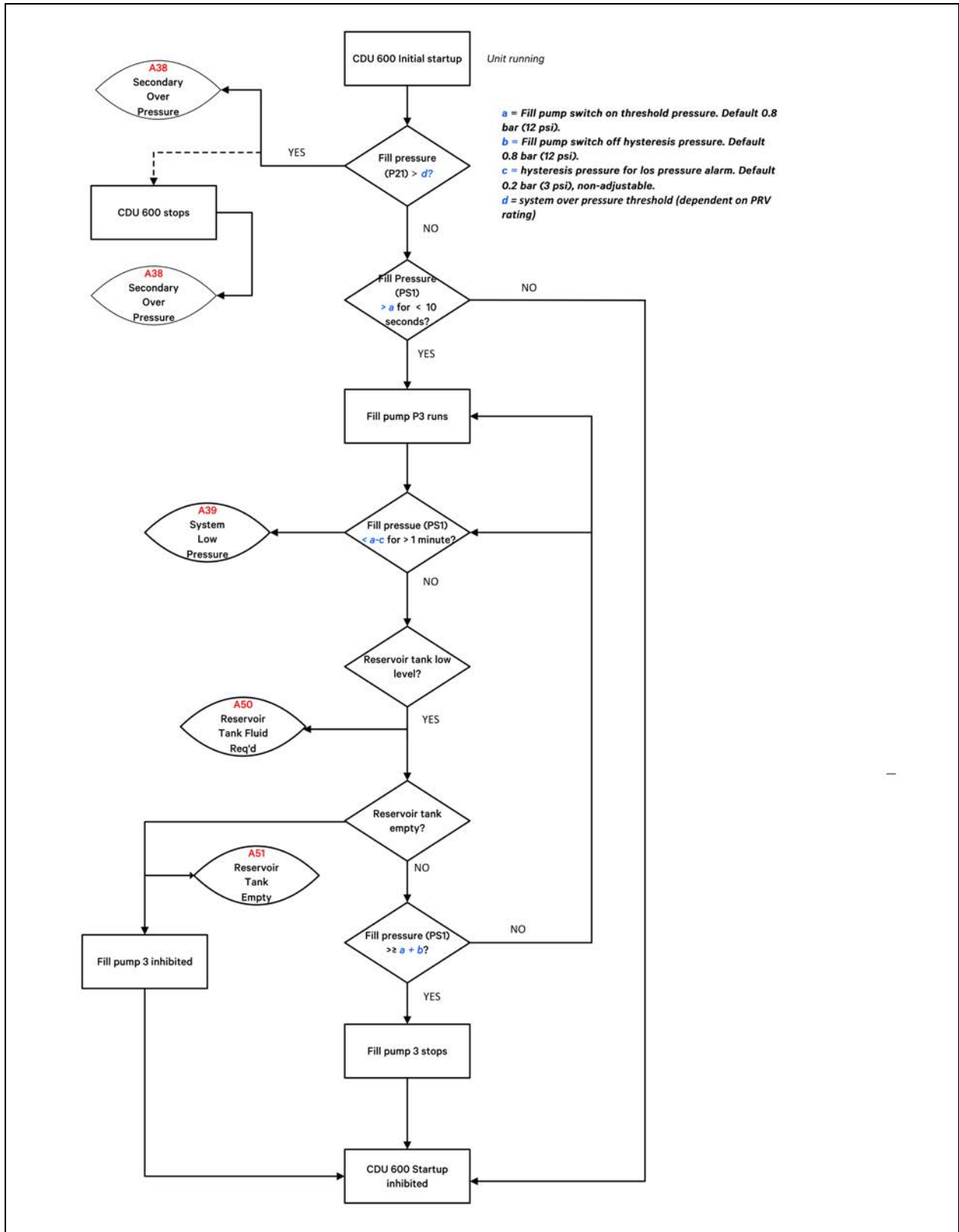

Figure 4.16 Fill Pressure and Level Flow Chart at Initial Start

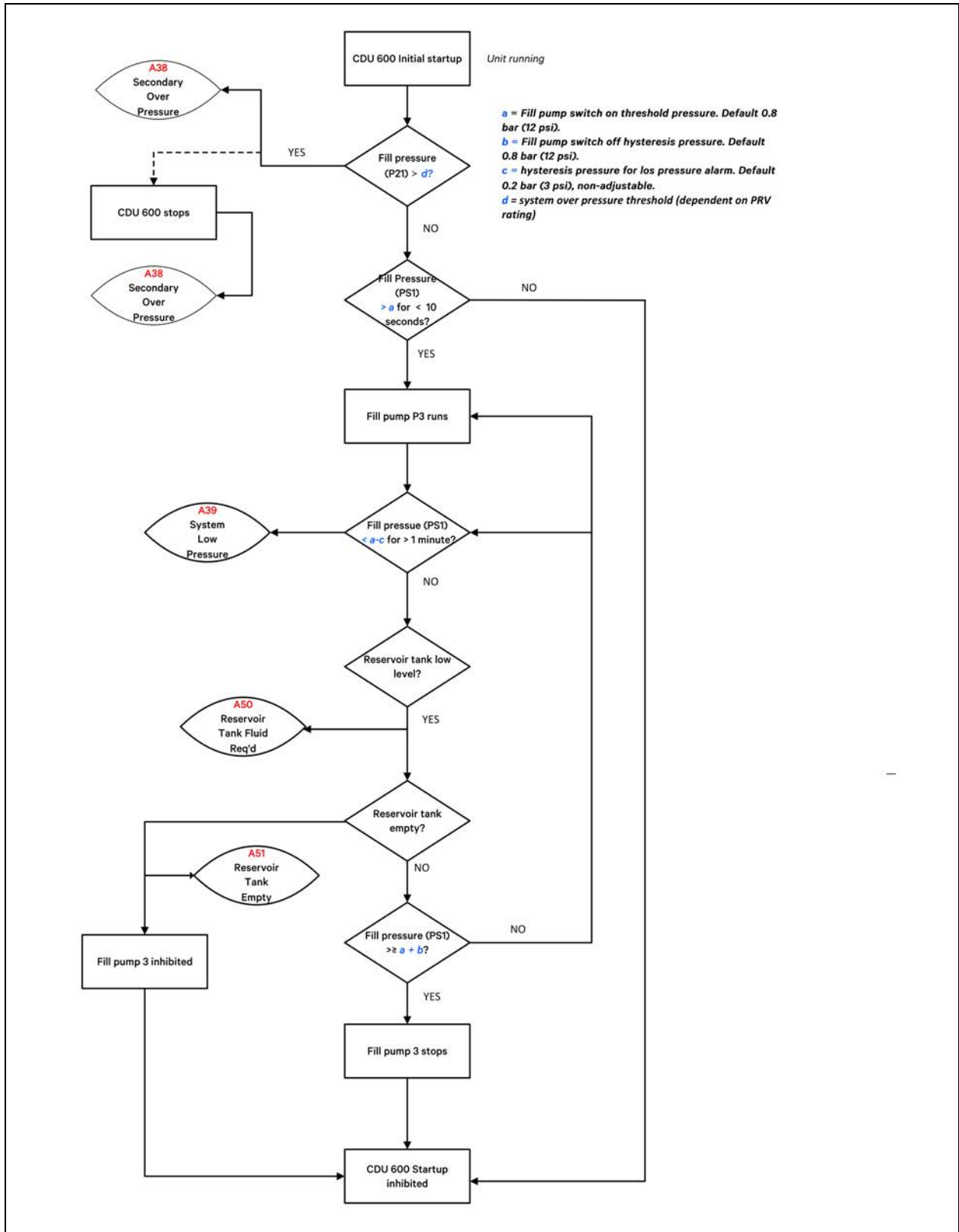
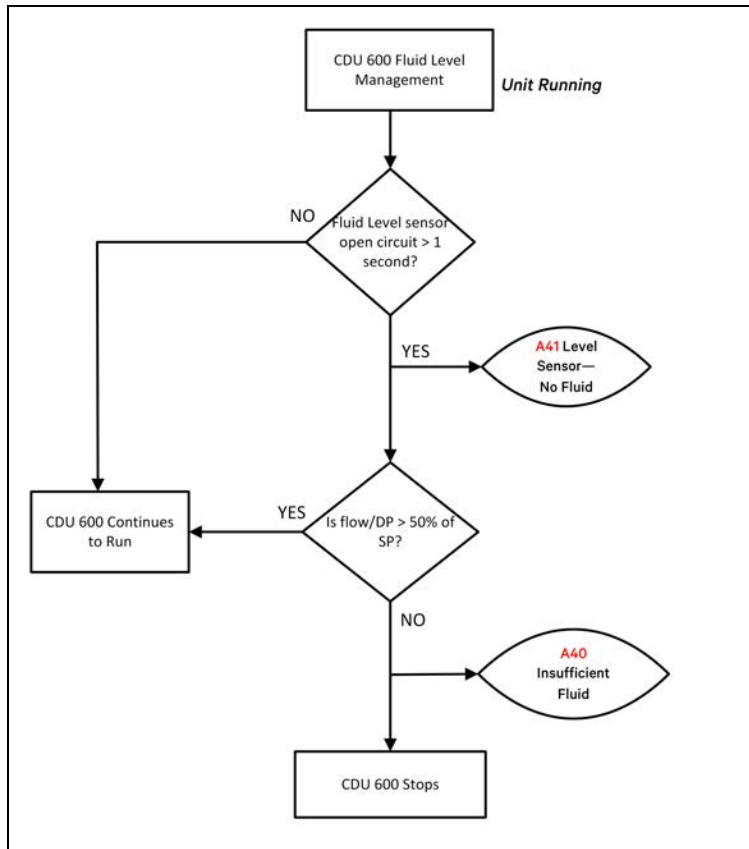

Figure 4.17 Fluid Level Management Flow Chart When Running



Secondary Supply Temperature Control Logic

The secondary fluid temperature is monitored close to the secondary circuit supply connection. Three temperature sensors are positioned here to give extended component redundancy (T2a, T2b, and T2c). The controller takes an average between all 3 readings as its input value.

- If the difference between sensors exceeds a default of 1.0°C (2°F), an A47, A48, or A49—Secondary Temp T2a (T2b or T2c) Diff Fault alarm is raised after a default delay of 30 seconds. The controller only reads and averages the two remaining healthy sensors.
- If any of the T2 temperature sensors go open circuit, then an A02 (A03 or A04)—T2a (T2b or T2c) Secondary Temperature Sensor Fault alarm is raised with no time delay. The controller only reads and averages the two remaining healthy sensors.

Temperature sensor (T4) monitors the secondary circuit return temperature and is used in conjunction with the flow rate to calculate the heat transfer duty.

Fixed SP Control Mode

The secondary temperature should correspond to the desired setpoint. The default fixed setpoint is 18°C (65°F) and is used by the control loop to regulate the primary fluid cooling valve position to achieve and maintain the setpoint. The cooling valve position can be monitored on the Home screen or page 1 of the Status screen (Cooling Demand/Feedback). High and low temperature alarms are set at a default value of 2°C (4°F) either side of setpoint (floating with the setpoint) when either Fixed SP or Fixed SP + Dew Point Offset control mode is selected from Configuration—Temperature Control screen, with a default hysteresis of 1°C (2°F).

- The high and low temperature alarms are ignored for a default period of 20 minutes on startup to allow the system time to settle without generating nuisance alarms.
- If the secondary temperature deviates by more than 2°C (4°F) below setpoint for 2 minutes or more, an A32—Secondary Fluid Low Temp alarm is generated. This alarm will remain present until the temperature rises above the hysteresis value.
- If the secondary temperature deviates by more than the default of 2°C (4°F) above setpoint for 2 minutes or more, an A33—Secondary Fluid High Temp alarm will be generated. This alarm will remain present until the temperature falls below the hysteresis value.

4.4 Temperature Control Loop

If necessary to change the PID settings for temperature control, it is recommended that the Ziegler-Nichols manual tuning method be adopted.

IMPORTANT! The Ziegler-Nichols method requires that the system is operating under typical load conditions. Initially, it causes the control loop to temporarily become unstable with wide temperature swing oscillations. It is important to ensure that this does not cause any damage to the equipment being cooled. Logging on at the Engineering level provides the access to make these changes.

1. Set the Integral Reset Time and Derivative Reset Time (Configuration—Temperature Control screens P309 and P310) to 0 seconds.
2. Increase the Proportional Band (Configuration—Temperature Control screen P308) to a higher value from the default. For example, 20°C.
3. Check that the Secondary Supply Temperature (T2) stabilizes.

NOTE: Temperature stabilizes at a higher temperature than the current setpoint. This offset is eradicated once the Integral reset time is added back in.

4. If temperature control is unstable, raise the Proportional Band to a higher value until the temperature stabilizes. Otherwise gradually decrease the Proportional Band in 1°C steps until the supply temperature (T2) starts to oscillate at a constant rate.
5. Measure the frequency of the oscillation time (peak to peak) in seconds (t).

4.4.1 PI Control

PI control should be sufficient for systems that have a reasonably steady or slow changing heat loads.

1. Set the Proportional Band to 2.2X the Proportional Band setting at which the system became unstable.
2. Set the Integral Reset Time to 0.83X the oscillation time (t).
3. Leave the Derivative Reset Time at 0.

4.4.2 PID Control

PID control is generally the preferred option for systems that see high or suddenly changing heat loads.

1. Set the Proportional Band to 1.67X the Proportional Band sitting at which the system became unstable.
2. Set the Integral Reset Time to 0.5X the oscillation time (t).
3. Set the Derivative Reset Time to 0.125X the oscillation time (t).

4.5 Alarm Management

When an alarm occurs, a flashing alarm bell icon will immediately break through at the top right-hand corner of the Home screen, with the number of active alarms stated below.

Figure 4.18 Control Screen Alarm Indication

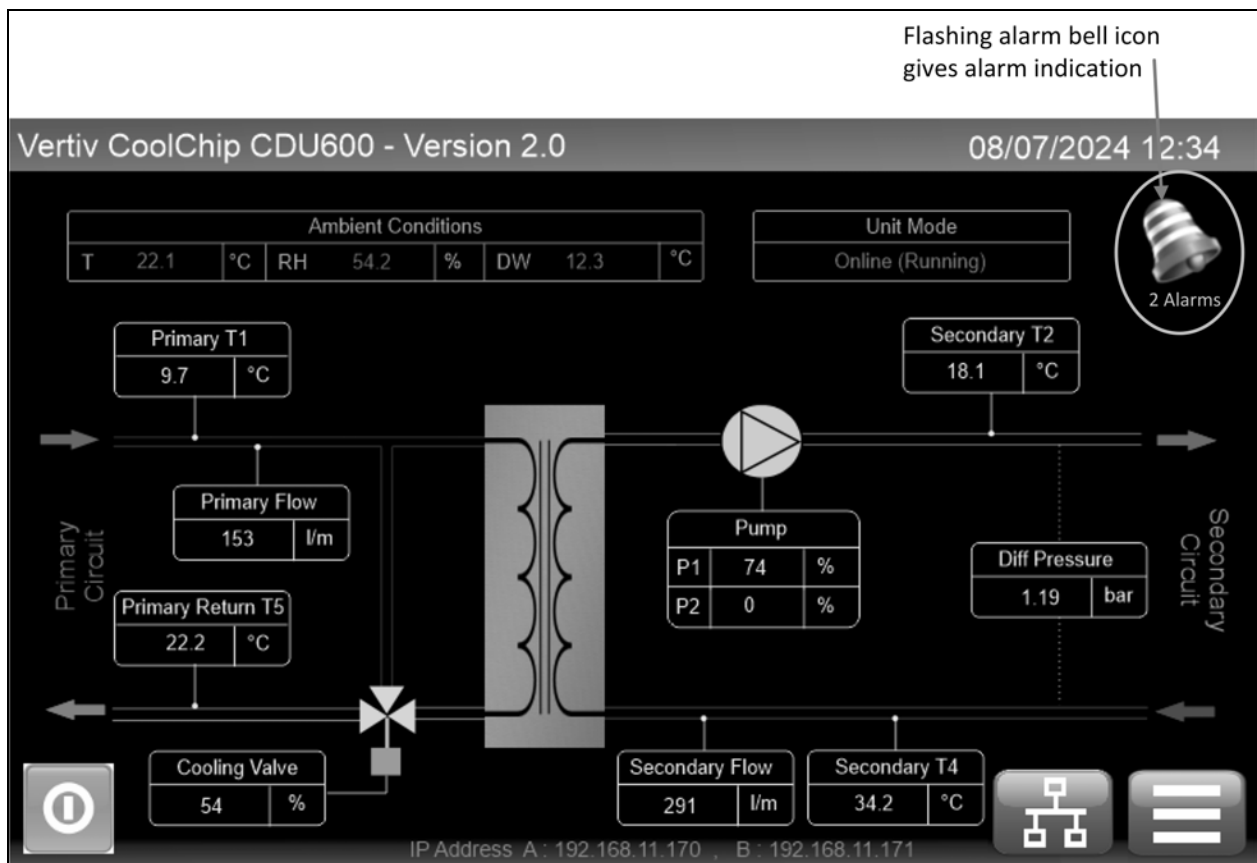

Pressing the alarm bell icon brings up the Alarm page. This identifies which alarms are active. See [Figure 4.19](#) on the next page.

Figure 4.19 Control Screen Active Alarms

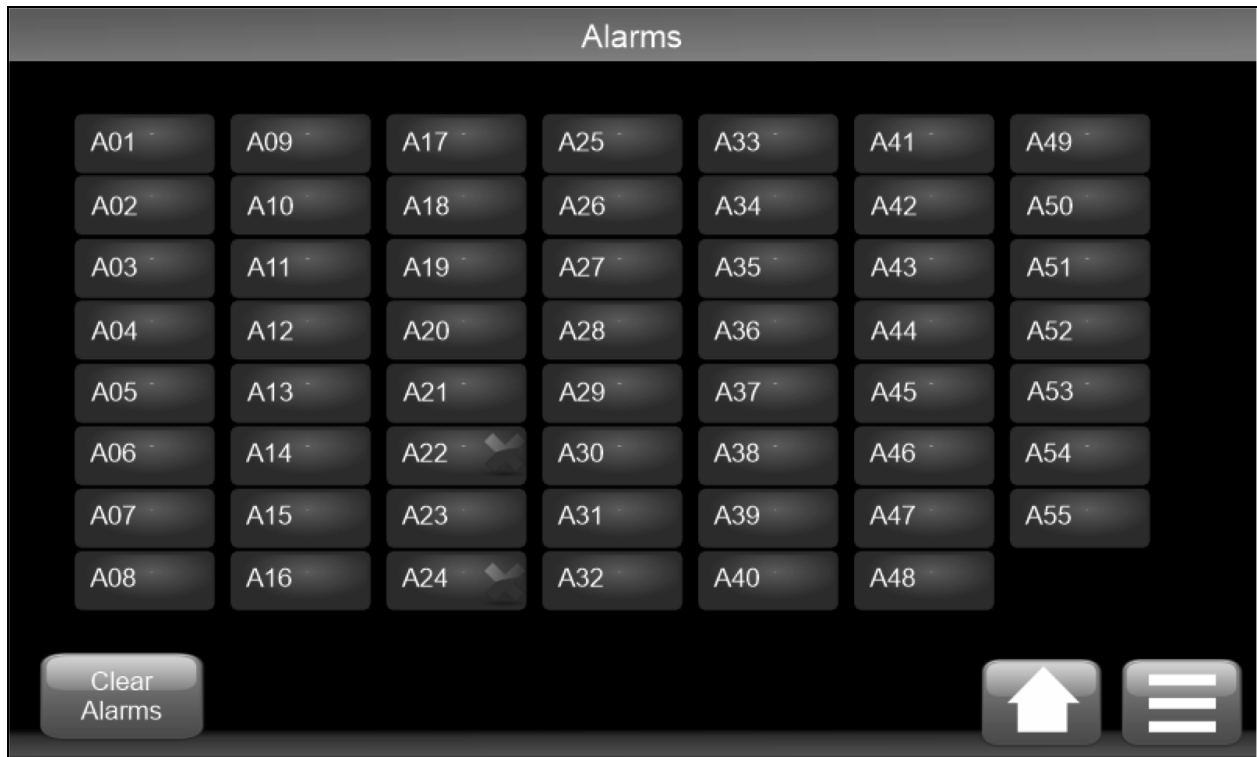

Select the alarm to view a description of the alarm.

Some alarms self-clear if the condition is transient. For example, a temperature goes over an alarm threshold and then comes back to a healthy condition or the fault has been rectified such as when a faulty sensor has been replaced.

Log onto the Service level or higher to clear latching alarms manually and then press Clear Alarms (see **Figure 4.19** above)

Self-clearing and latching alarms are identified in 51.

All alarms are automatically logged in an Alarm Log file stored on the controller SD card with the time and date of generation.

Figure 4.20 Control Screen Alarm Identification

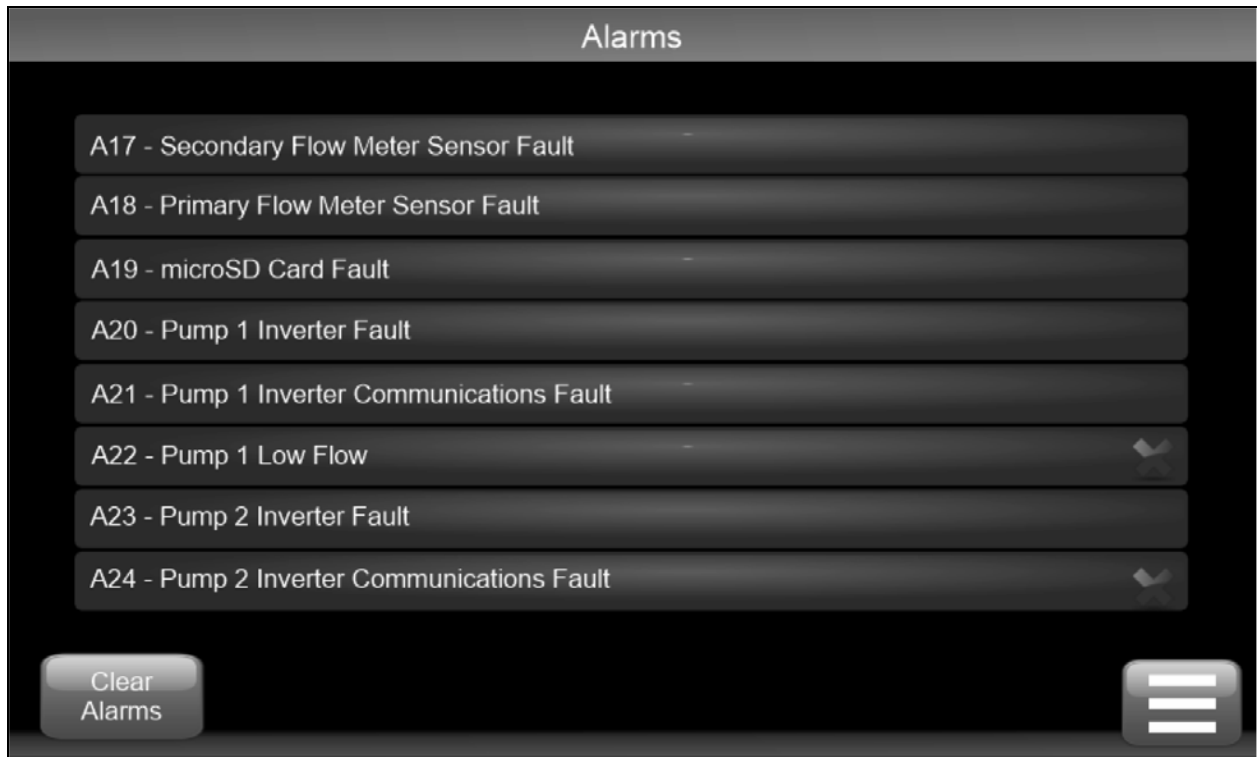

4.6 Troubleshooting Alarms

Alarms are events which may cause the unit to shutdown and should be immediately investigated.

IMPORTANT! Table 4.41 on the next page provides the full list of all alarms. However not all are necessarily active, depending on the unit configuration. For example, if the CDU has not been fitted and configured for a primary filter, then the associated A29—Filter Dirty alarm will not be active.

Alarms that are indicated with an asterisk beside the code number may not be active depending upon unit configuration.

Severity classifications:

1. Unit shutdown. (Shutdown IT immediately.)
2. Urgent alarm. (Immediate investigation required, prepare to shut down IT if needed.)
3. Non-urgent alarm. (Investigate within 4 days.)
4. Information only. (Respond when required or at PPM.)

In Table 4.41 on the next page, SC indicates the severity classification. These classifications are suggested only. Customers may wish to assign their own ratings.

Table 4.41 Alarm Identification and Severity Level

Code	Description	Severity	Self-Clear	Latching	Shutdown	Shutdown
----	No Display	—	✓	—	—	—
Detail:	Display not illuminated. Power failure on display board or controller I/O board.					
Action:	Open upper electrical panel door to check that 24V DC is available at controller I/O board. If there are no LEDs showing on processor board, then check I/O board 24V fuse FS1. If LEDs are on, check for wiring faults between I/O board and display.					
A01	T1 Primary Temperature Sensor Fault	3	✓	—	—	—
Detail:	Reading from primary temperature sensor T1 is outside the normal range of -5°C to 74°C (23°F to 165°F) or disconnected.					
Action:	Check sensor connections to control board, check inline connections, replace sensor.					
A02	T2a Secondary Temperature Sensor Fault	3	✓	—	—	—
Detail:	Reading from secondary supply temperature sensor T2a is outside the normal range of 5 to 74°C (41 to 165°F) or disconnected.					
Action:	Check sensor connections to the control board, check inline connections, replace sensor.					
A03	T2b Secondary Temperature Sensor Fault	3	—	—	—	—
Detail:	Reading from secondary supply temperature sensor T2b is outside the normal range of 5 to 74°C (41 to 165°F) or disconnected.					
Action:	Check sensor connections to the control board, check inline connections, replace sensor.					
A04	T2c Secondary Temperature Sensor Fault	3	—	—	—	—
Detail:	Reading from fluid supply temperature sensor T3b is outside the normal range of 5 to 74°C (41 to 165°F), or disconnected.					
Action:	Check sensor connections to the control board, check inline connections, replace sensor.					
A05	T3 Room Temperature Sensor Fault	3	✓	—	—	—
Detail:	Reading from Room temperature sensor T3 is outside the normal range of 5 to 70°C (41 to 158°F), or disconnected.					
Action:	Check sensor connections to the control board, check in-line connections, replace sensor.					
A06	T4 Secondary Temperature Sensor Fault	3	✓	—	—	—
Detail:	Reading from Secondary return temperature sensor T4 is outside the normal range of 5 to 70°C (41 to 158°F), or disconnected.					
Action:						
A07	T5 Primary Temperature Sensor Fault	3	✓	—	—	—
Detail:	Reading from Primary return temperature sensor T4 is outside the normal range of 5 to 70°C (41 to 158°F), or disconnected.					
Action:	Check sensor connections to the control board, check inline connections, replace sensor.					
A08	RH Relative Humidity Sensor Fault	3	✓	—	—	—
Detail:	Reading from Room humidity sensor RH is outside the normal range of 5 to 100% RH or disconnected. Note: if in Fixed Setpoint + DW Offset mode, unit will revert to Fixed Setpoint mode – default 18°C (65°F).					

Table 4.41 Alarm Identification and Severity Level (continued)

Code	Description	Severity	Self-Clear	Latching	Shutdown	Shutdown
Action:	Check sensor connections to the control board, check inline connections, replace sensor.					
A09	PS1a Secondary Pressure Sensor Fault	3	✓	—	—	—
Detail:	Reading from Secondary return pressure sensor PS1a (Fill pressure) is outside the normal range of -1 to 8 bar (-15 to 116 PSI) and min/max values only will be displayed. Note: for DP control, if system differential pressure is not valid, then pump speed will remain at last known demand.					
Action:	Use external fluid source, engage filling wand and fill pump P4 to refill the reservoir tank					
A10	PS1b Secondary Pressure Sensor Fault	3	✓	—	—	—
Detail:	Reading from secondary return pressure sensor PS1b (also staticFillpressure) is outside the normal range of -1 to 8 bar (-15 to 116 PSI) and min/max values only will be displayed. Note: for DP control, if system differential pressure is not valid, then pump speed will remain at last known demand.					
Action:	Check sensor connections to the control board, check inline connections, replace sensor.					
A11	PS2a Secondary Pressure Sensor Fault	3	✓	—	—	—
Detail:	Reading from Secondary supply pressure sensor PS2a is outside the normal range of -1 to 8 bar (-15 to 116 PSI) and min/ max values only will be displayed [Note: for DP control, if system differential pressure is not valid, then pump speed will remain at last known demand].					
Action:	Check sensor connections to the control board, check inline connections, replace sensor.					
A12	PS2b Secondary Pressure Sensor Fault	3	✓	—	—	—
Detail:	Reading from secondary return pressure sensor PS2b (also static Fill pressure) is outside the normal range of -1 to 8 bar (-15 to 116 psi) and min/max values only will be displayed. Note: for DP control, if system differential pressure is not valid, then pump speed will remain at last known demand.					
Action:	Check sensor connections to the control board, check inline connections, replace sensor.					
A13*	PS3 Primary Pressure Sensor Fault	3	✓	—	—	—
Detail:	Reading from primary filter inlet pressure sensor PS3 is outside the normal range of -1 to 8 bar (-15 to 116 psi) and min/max values only will be displayed Note: if filter differential pressure is not valid, then pump speed will remain at last known demand.					
Action:	Check sensor connections to the control board, check inline connections, replace sensor.					
A14*	PS4 Primary Pressure Sensor Fault	3	✓	—	—	—
Detail:	Reading from primary filter outlet pressure sensor PS4 is outside the normal range of -1 to 8 bar (-15 to 116 psi) and min/max values only will be displayed Note: if filter differential pressure is not valid, then pump speed will remain at last known demand.					
Action:	Check sensor connections to the control board, check inline connections, replace sensor.					
A15*	PS5a Secondary Pressure Sensor Fault	3	✓	—	—	—
Detail:	Reading from secondary filter inlet pressure sensor PS5a (Pump 1 outlet) is outside the normal range of -1 to 8 bar (-15 to 116 psi) and min/max values only will be displayed.					
Action:	Check sensor connections to the control board, check inline connections, replace sensor.					
A16*	PS5b Secondary Pressure	3	✓	—	—	—

Table 4.41 Alarm Identification and Severity Level (continued)

Code	Description	Severity	Self-Clear	Latching	Shutdown	Shutdown
	Sensor Fault					
Detail:	Reading from secondary filter inlet pressure sensor PS5b (Pump 2 outlet) is outside the normal range of -1 to 8 bar (-15 to 116 psi) and min/max values only will be displayed.					
Action:	Check sensor connections to the control board, check inline connections, replace sensor.					
A17	Secondary Flow Meter Sensor Fault	2	✓	—	—	—
Detail:	Secondary flow meter output is below 4mA.					
Action:	Check sensor connections to the control board, check inline connections, replace sensor.					
A18*	Primary Flow Meter Sensor Fault	3	✓	—	—	—
Detail:	Primary flow meter output is below 4mA.					
Action:	Check sensor connections to the control board, check inline connections, replace sensor.					
A19	MicroSD Card Fault	3	✓	—	—	—
Detail:	The SD card has either been removed or physically damaged.					
Action:	Replace the SD card.					
A20	Pump P1 Inverter Fault	2	✓	—	—	—
Detail:	Pump 1 is drawing excessive current, or inverter has been subjected to over/under voltage. Alarm will only appear after inverter has gone into fault condition a second time (default), after first attempting a fault reset. Pump 1 will then run.					
Action:	Note any fault code on the inverter display and contact Vertiv for more information/corrective action.					
A21	Pump P1 Inverter Communications Fault	2	—	—	—	—
Detail:	Controller unable to communicate with pump Inverter 1,					
Action:	Check wiring and terminations,					
A22	Pump 1 Low Flow	2	—	✓	—	—
Detail:	Pump 1 has not reached the flow rate (or differential pressure) setpoint in the specified time limit (default 100 secs).					
Action:	Check that unit has been set for the correct system flow rate (or DP), check for system blockages, check inverter drive for faults, check non-return valves on Pumps are not sticking open (Pump rotating slowly backwards). Reduce flow setting (or DP).					
A23	Pump P2 Inverter Fault	2	—	✓	—	—
Detail:	Pump 2 is drawing excessive current, or inverter has been subjected to over/under voltage. Alarm will only appear after inverter has gone into fault condition a second time (default), after first attempting a fault reset. Pump 2 will then run.					
Action:	Note any fault code on the inverter display and contact Vertiv for more information/corrective action.					
A24	Pump P2 Inverter Communications Fault	2	—	✓	—	—
Detail:	Controller unable to communicate with pump Inverter 2.					
Action:	Check wiring and terminations.					
A25	Pump 2 Low Flow	2	—	✓	—	—

Table 4.41 Alarm Identification and Severity Level (continued)

Code	Description	Severity	Self-Clear	Latching	Shutdown	Shutdown
Detail:	Pump 2 has not reached the flow rate (or differential pressure) setpoint in the specified time limit (default 100 secs).					
Action:	Check that unit has been set for the correct system flow rate (or DP), check for system blockages, check inverter drive for faults, check non-return valves on Pumps are not sticking open (Pump rotating slowly backwards). Reduce flow setting (or DP).					
A26	Valve Fault	2	—	✓	—	—
Detail:	Feedback signal from cooling valve is more than 10% (default) adrift from demand signal (sampled every 15 minutes (default) and allowing for 40 second (default) positioning time).					
Action:	Check that unit has been set for the correct system flow rate (or DP), check for system blockages, check inverter drive for faults, check non-return valves on Pumps are not sticking open (Pump rotating slowly backwards). Reduce flow setting (or DP).					
A27	Primary Fluid Low Flow	2	—	✓	—	—
Detail:	Will only activate when valve demand is at 100%; A33 - Secondary Fluid High Temp alarm is active and Primary fluid temperature is within specified limits (default 5 min. delay applies).					
Action:	Check the wiring connections to the actuator. Try to set the actuator position manually using the Auto Overrides function. Check the voltage out and return signals (Page 1 of Diagnostics screen).					
A28	Primary Fluid No Flow	2	—	✓	—	✓
Detail:	Will only activate when Valve Demand is at 100%, A33 - Secondary Water High Temp and A31 - Primary High Temp alarms are active (default 5 minute delay applies).					
Action:	Check operation of cooling valve. Check primary fluid supply flow rate. Ensure system heat load does not exceed the CDU 600 capacity— check that primary flow is sufficient for heat load. Refer to CoolChip CDU 600 Application and Planning Guide.					
A29*	Primary Filter Dirty	2	✓	—	—	✓
Detail:	Differential pressure across primary filter (if fitted) is greater than 0.6 bar (9 psi), indicating that the filter should be cleaned (default 60 second delay applies).					
Action:	Clean filter screen as described in 67.					
A30	Primary Fluid Low Temperature	3	✓	—	—	✓
Detail:	Primary fluid temperature has dropped below the default 4°C (40°F) threshold. Alarm will cancel when temperature rises to 5°C (42°F) or more (default 2 minute. delay applies).					
Action:	Check primary fluid supply.					
A31	Primary Fluid High Temperature	2	✓	—	—	✓
Detail:	Primary fluid temperature has risen above the default 11°C (52°F) threshold. Alarm will cancel when temperature falls to 10°C (50°F) or less (default 2 minute delay applies).					
Action:	Check primary fluid supply..					
A32	Secondary Fluid Low Temperature	2	✓	—	—	✓
Detail:	Secondary fluid temperature has dropped by more than 2°C (4°F) below set point (default). Alarm will cancel when temperature rises to 1°C (2°F) below set point or higher. If Dew Point Offset is active, then this alarm will only activate when at or below dew point for a period of 3 minutes or more (default 2 minute delay applies).					
Action:	Check operation of control valve..					
A33	Secondary Fluid High Temperature	2	✓	—	—	✓

Table 4.41 Alarm Identification and Severity Level (continued)

Code	Description	Severity	Self-Clear	Latching	Shutdown	Shutdown
Detail:	Secondary fluid temperature has risen by more than 2°C (4°F) above set point (default). Alarm will cancel when temperature falls to 1°C (2°F) above setpoint or lower. If Dew Point Offset is active, then this alarm will activate at a pre-set default value of 20°C (70°F). See Parameters screen 3-12 (default 2 minute delay applies).					
Action:	Check operation of cooling valve.					
A34	Leak - Unit	1	—	✓	✓ (or not)	—
Detail:	Level switch in cabinet drip tray has detected a substantial fluid leak. Event may be set for Alarm Only (default), or Alarm + Unit Shutdown.					
Action:						
A35	Leak - External	1	—	✓	✓ (or not)	—
Detail:	The leak detection tape installed under the floor (if fitted – optional extra) has detected a substantial fluid leak. Alarm may be set for Alarm Only (default), or Alarm + Unit Shutdown.					
Action:	Identify and repair the leak. (Note: A leak of this magnitude that does not bring up any other alarms, would most likely be from the Primary circuit).					
A36	PS1 Difference Out of Limits	3	✓	—	—	—
Detail:	Difference between Secondary return pressure sensors PS1a and PS1b is more than 0.2 bar (3PSI), (default) for a period of 30 seconds (default) or more. Controller will continue to read just the higher of the 2 values.					
Action:	Check T2a sensors against temperature sensor resistance chart in Section 2.5 and replace if faulty.					
A37	PS4 Difference Out of Limits	3z	✓	—	—	—
Detail:	Difference between Secondary return pressure sensors PS4a and PS4b is more than 0.2 bar (3PSI), (default) for a period of 30 seconds (default) or more. Controller will continue to read just the higher of the 2 values.					
Action:	Replace sensor with the lower reading.					
A38	Sec. Over Pressure	1	✓	—	✓ or not	—
Detail:	Pressure at PS2 has increased above the set value of 6 bar (87PSI) (default). Alarm may be set for Alarm Only (default), or Alarm + Unit Shutdown.					
Action:	Most likely cause will be excessive heat build-up in the system, or a breach between Primary and Secondary circuits within the plate heat exchanger. Check for High Temp alarms, check bladder in expansion vessel(s) has not ruptured, relieve pressure at drain point. Remove heat exchanger and replace.					
A39	System Low Pressure	2	—	✓	—	✓
Detail:	Pressure at PS1 has dropped more than 0.2Bar (3 psi) (set, non-adjustable) below fill pump activation threshold for more than 1 minute (set, non-adjustable, applicable when unit is running in automatic/online mode).					
Action:	Check amount of fluid in make up container and re-fill if necessary. Ensure fill pump hoses are free of air locks, container is properly connected and fill pump is operational. Check system for leaks.					
A40	Insufficient Fluid	1	—	✓	✓	—
Detail:	On Initial Start-up – if level sensors are not made, fill pressure has not been achieved and fill pump has been running for more than 1 minute, then unit will not start or shutdown immediately. While Unit is Running – This will be in conjunction with an A41 – Level Sensor – No Fluid Detected alarm (refer to A41 for detail). If level sensors are not made and flow or DP is < 50% of flow/DP setpoint, then unit will shutdown after a 1 second delay.					
Action:	Check that water make-up container is properly connected (or filling wand is fully immersed, if used). Check system for leaks. Check there is no trapped air in fill pump hoses and system is fully vented. Check auto air vents are open.					
A41	Level Sensor – No Fluid	2	—	✓	—	—

Table 4.41 Alarm Identification and Severity Level (continued)

Code	Description	Severity	Self-Clear	Latching	Shutdown	Shutdown
	Detected					
Detail:	While unit is running only – if both Level sensors are open circuit for more than 1 second then this alarm will be raised, providing flow or DP (depending on control function set) is >50% of flow/DP setpoint. If flow/DP is below this threshold, then an A40 - 'Insufficient Fluid' alarm (refer to A43 for detail) will be raised and unit will shutdown after a 1 second delay.					
Action:	Check that water make-up container is properly connected (or filling wand is fully immersed, if used). Check system for leaks. Check there is no trapped air in fill pump hoses and system is fully vented. Check auto air vents are open.					
A42	Illegal Fluid Sensor Condition	2	✓	—	—	—
Detail:	On Initial Start-up – if fill pressure has been achieved, but level sensors are not made.					
Action:	Likely cause is trapped air. Vent air from Secondary circuit.					
A43*	Group Control Network Fault	2	✓	—	—	—
Detail:	Comms failure between CDUs on network					
Action:	Check wiring and terminations					
A44*	Group Control Insufficient Units Available	2	✓	—	—	—
Detail:	Group control cannot bring a redundant unit on-line because it's either in a fault condition, has locally been put into standby mode, or has a comms. failure.					
Action:	Check status of redundant unit, check wiring and terminations					
A45*	Secondary Filter 1 Dirty	3	✓	—	—	—
Detail:	Differential pressure across Secondary filter 1 (if fitted) is greater than 0.2 bar (3PSI), indicating that the filter should be cleaned (default 60 second delay applies).					
Action:	Clean filter screen as described in the Maintenance Section.					
A46*	Secondary Filter 2 Dirty	3	✓	—	—	—
Detail:	Differential pressure across Secondary filter 2 (if fitted) is greater than 0.2 bar (3PSI), indicating that the filter should be cleaned (default 60 second delay applies).					
Action:	Clean filter screen as described in 70					
A47*	Secondary Temp T2a Diff Fault	2	✓	—	—	—
Detail:	Difference between Secondary temp. sensor T2a is more than default 1°C (2°F) adrift from T2b and T2c, for a period of 30 seconds (default) or more. Controller will read the average of T2b and T2c only.					
Action:	Check T2a sensors against temperature sensor resistance chart in Section 2.5 and replace if faulty.					
A48*	Secondary Temp T2b Diff Fault	3	✓	—	—	—
Detail:	Difference between Secondary temp. sensor T2b is more than default 1°C (2°F) adrift from T2a and T2c, for a period of 30 seconds (default) or more. Controller will read the average of T2a and T2c only.					
Action:	Check T2b sensors against temperature sensor resistance chart in Section 2.5 and replace if faulty.					
A49	Secondary Temp T2c Diff Fault	3	✓	—	—	—
Detail:	Difference between Secondary temp. sensor T2c is more than default 1°C (2°F) adrift from T2a and T2b, for a period of 30 seconds (default) or more. Controller will read the average of T2a and T2c only.					

Table 4.41 Alarm Identification and Severity Level (continued)

Code	Description	Severity	Self-Clear	Latching	Shutdown	Shutdown
Action:	Check T2c sensors against temperature sensor resistance chart in Section 2.5 and replace if faulty.					
A50	Reservoir Tank Fluid Required	3	✓	—	—	—
Detail:	Fluid level in the reservoir tank has dropped to the low level sensor.					
Action:	Use external fluid source, engage filling wand & pump P5 to refill the reservoir tank					
A51	Reservoir Tank Empty	2	✓	—	—	—
Detail:	Fluid level in the reservoir tank has dropped to the very low level sensor and unit fill pump P4 operation is inhibited.					
Action:	Use external fluid source, engage filling wand & fill pump P5 to refill the reservoir tank					
A52*	Auxiliary IO Module Communications Fault	3	✓	—	—	—
Detail:	Controller unable to communicate with auxiliary IO module.					
Action:	Check wiring and terminations.					
A53*	Turbidity Sensor Fault	3	✓	—	—	—
Detail:	Turbidity sensor output is below 4mA.					
Action:	Check sensor connections to the IO module, check in-line connections, replace sensor.					
A54*	PH Sensor Fault	3	✓	—	—	—
Detail:	PH sensor output is below 4mA.					
Action:	Check sensor connections to the IO module, check in-line connections, replace sensor.					
A55*	Conductivity Sensor Fault	3	✓	—	—	—
Detail:	Conductivity sensor output is below 4mA.57					
Action:	Check sensor connections to the IO module, check in-line connections, replace sensor.					
A56*	Turbidity Sensor Out of Limits	3	✓	—	—	—
Detail:	Turbidity sensor output is below or above configured limits.					
Action:	Check fluid quality.					
A57*	PH Sensor Out of Limits	3	✓	—	—	—
Detail:	PH sensor output is below or above configured limits.					
Action:	Check fluid quality.					
A58*	Conductivity Out of limits	3	✓	—	—	—
Detail:	Conductivity sensor output is below or above configured limits.					
Action:	Check fluid quality.					

5 CANbus Communication Troubleshooting

The CANbus network health is indicated on the Home screen via the CANbus status icon.

Figure 5.1 CANbus Status Icon



When the icon indicates a network fault (red), view the network status screens to determine which devices on the network are not communicating. The mode will indicate Comms Fail. If these devices are not intentionally powered off or not intentionally disconnected from the network, check network cabling and CANbus configuration.

5.1 Temperature Sensor Graph

Figure 5.2 below can be used to check the validity of the 10K thermistor temperature sensors used in the unit.

Figure 5.2 Temperature Sensor Resistance Graph

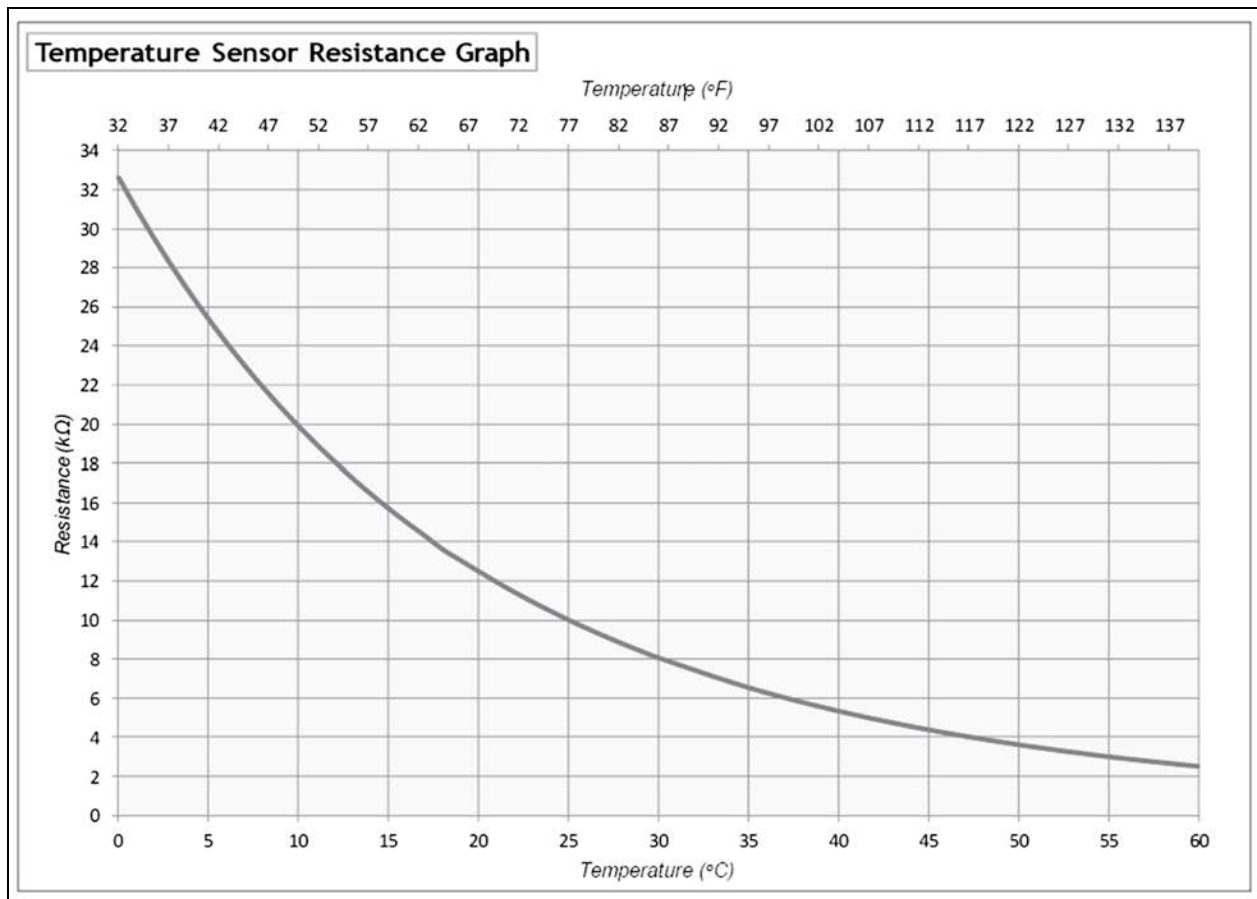

5.2 Manual Operation of Cooling Valve

If the control valve actuator completely fails, the secondary supply temperature can be controlled by manually overriding the valve actuator as detailed below.

IMPORTANT! Disconnect the valve actuator from the control panel first. Unplug the 4-way connector, terminals 9 to 12 from socket SK8. This ensures that the actuator maintains its manually set position.

Press the internal gear release button down and move the valve handle to the desired position. This allows the CoolChip CDU 600 unit to continue running and providing cooling until the valve actuator can be replaced.

Figure 5.3 Manual Operation of Cooling Valve

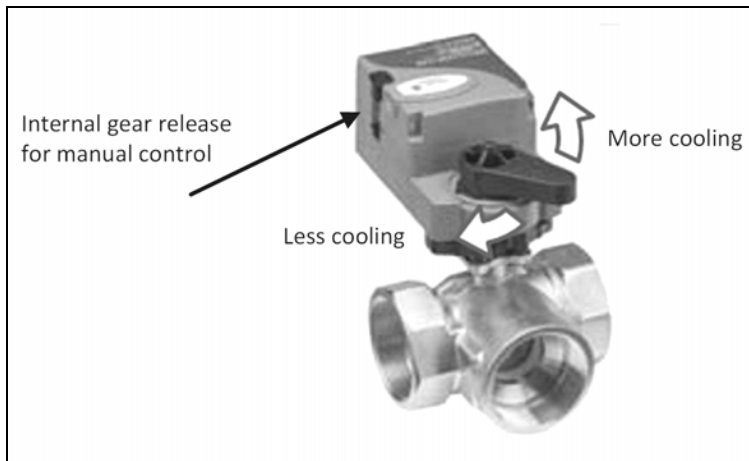

5.3 Group Control

This section to be considered only if there is more than one CoolChip CDU 600 unit installed per system.

Groups of up to 16 CoolChip CDU 600s can be connected using a high speed, robust twisted pair CANbus network in order to provide coordinated control in larger installations and N + X redundancy.

Figure 5.4 Group Control

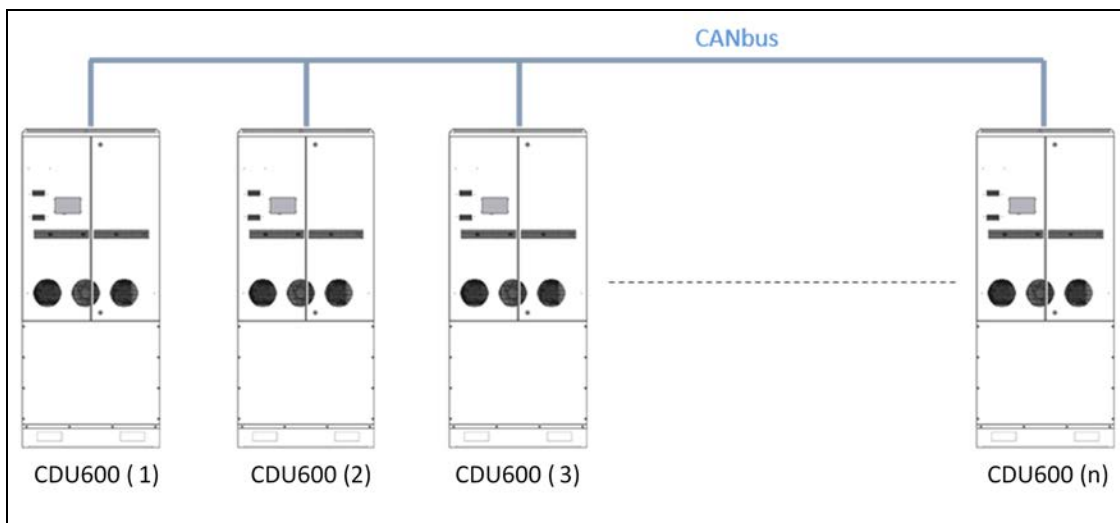

5.3.1 Group Control—Network Cabling

CANbus is used for communication between CDU 600 units for group control. CANbus always requires at least 3 conductors: 2 signal wires (CAN High and CAN L) and a 1 signal return path.

The CDU 600 provides 2 CAN H, 2 CAN L and 2 GND terminals on sockets SK9, 1, 2 and 3 for In and terminals 4, 5 and 6 for Out.

Belden 3106A, or equivalent (1 pair + 1 shielded 22AWG) is the recommended cable type to be used and pre-configured cable assemblies are provided with each unit if required.

Figure 5.5 Group Control Wiring Configuration

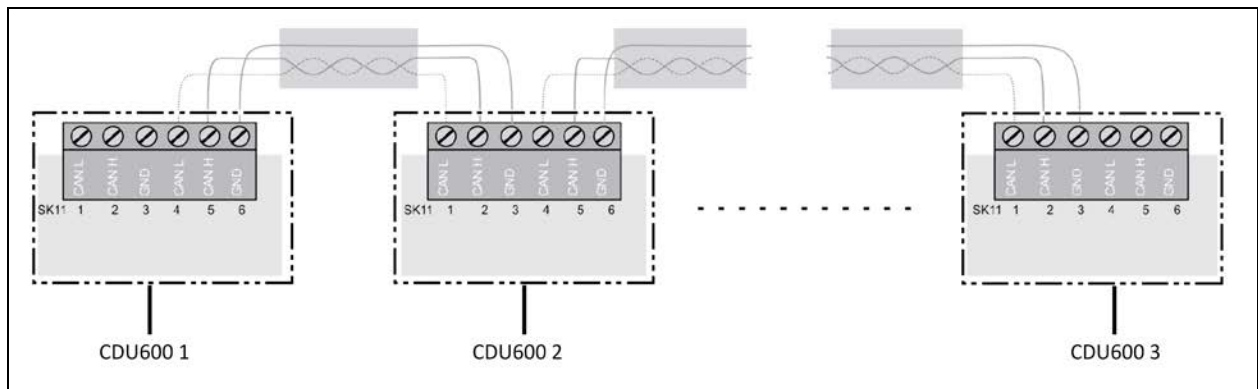

Units become self organizing when in group control. The lead unit is automatically selected which coordinates the running state of each unit in group based on:

- Configured level of redundancy
- System pressure requirements
- Alarm conditions

Changes to the group settings or system settings can be made via any CDU 600 touchscreen user interface at any time and are automatically synced across the network.

Figure 5.6 Group Control Status Screen

Group Control Status									
CDU	Mode	DP bar	Flow Rate l/m	Pump Speed %		Temp T2 °C	Cooling Demand %	Alarm	Lead
				P1	P2				
1	Online (Running)	1.89	230	55	0	18.2	67	0	1
2	Online (Running)	1.92	235	0	55	18.1	73	0	0
3	Online (Running)	1.97	210	55	0	18.0	59	0	0
4	Group Standby	1.76	0	0	0	18.8	0	0	0
5	Shutdown	1.23	0	0	0	19.2	0	1	0
6	Not In Group	0	0	0	0	0	0	0	0
7	Not In Group	0	0	0	0	0	0	0	0
8	Not In Group	0	0	0	0	0	0	0	0

Average System DP	1.93 bar	Total System Flow Rate	675 l/m
-------------------	----------	------------------------	---------

5.3.2 Group Control—Network Termination Resistors

The CDU 600 controller includes an onboard 120 ohm resistor which can be activated by fitting a hardware jumper. If only one CDU 600 unit is installed, the resistor does not require activation. For a two unit installation, both units should have the termination resistors enabled. For three or more units, units 1 and n should have the termination resistors enabled, while units between should be disabled. Failure to disable the middle resistors could result in intermittent communications. See **Figure 5.7** below and **Figure 5.8** on the facing page for the location of the jumper to enable/disable the termination resistor (the jumper is fitted by default and must be removed if not required).

Figure 5.7 CANbus Network Termination Resistors Wiring

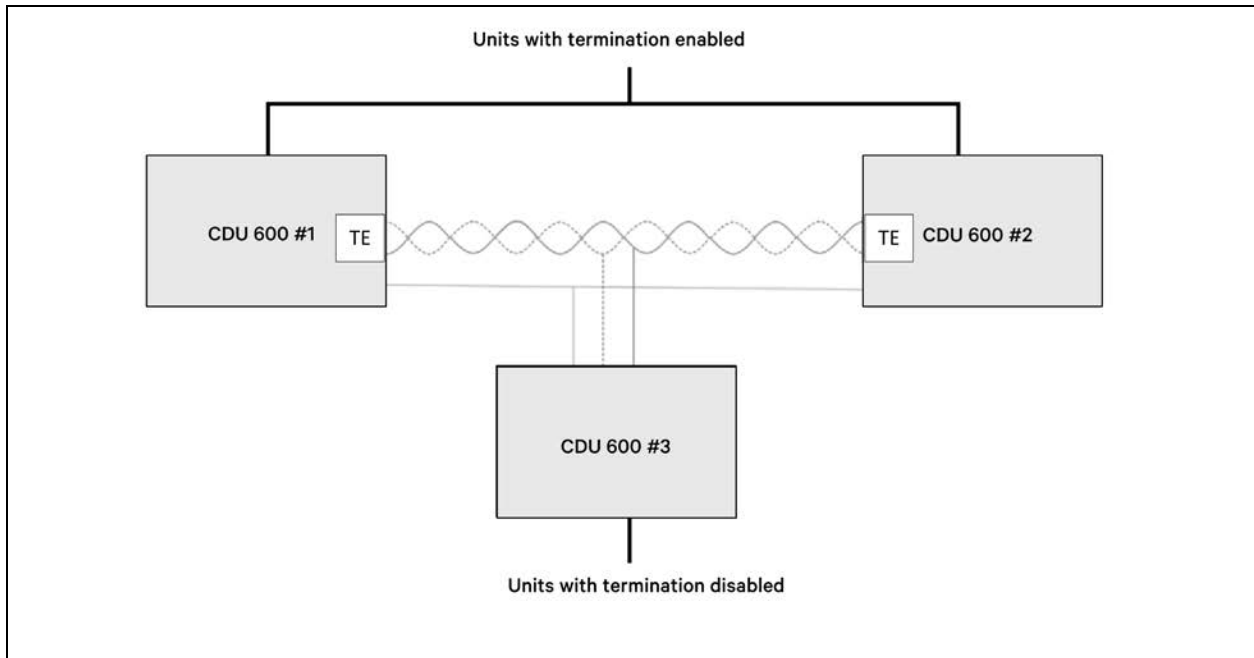
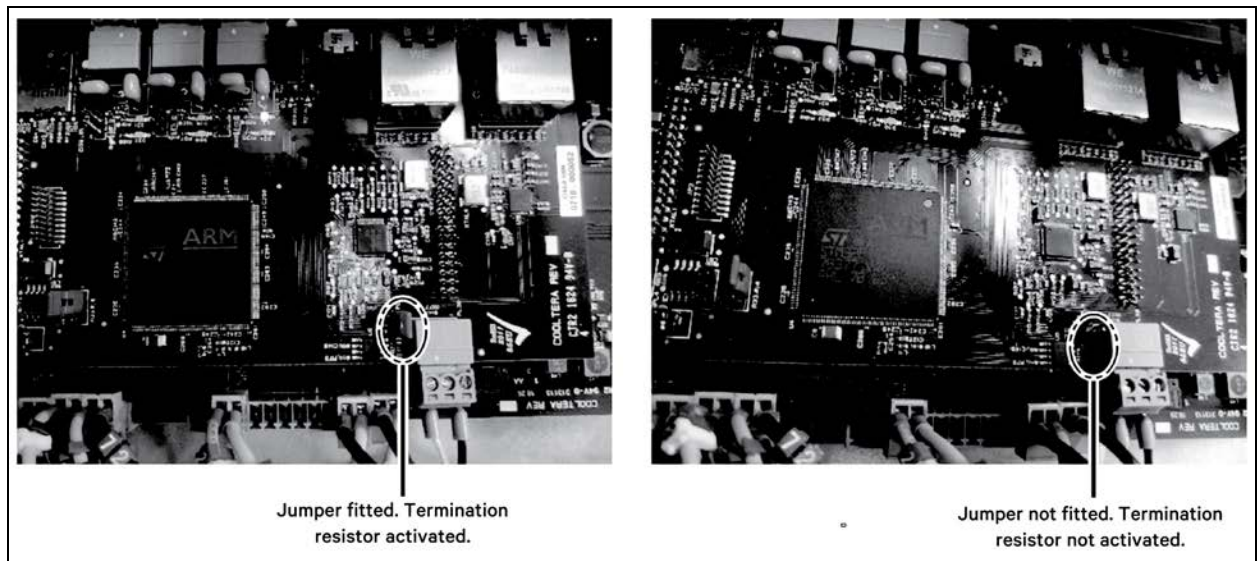

Figure 5.8 CANbus Network Termination Resistors



5.3.3 Group Control—Network Addresses

Each CoolChip CDU 600 must be given a unique address. A CDU 600 network address should be allocated to each unit in ascending order, starting from 1.

The CDU 600 network address is configured via Setup screen > Group Control > Unit Address (P081). Configure each CDU 600 so that it is aware of the other CDU 600 devices on the network:

- Enter the total number of CDU 600 units in the networked system via Setup screen > Group Control > Number of Units in Group (P082)
- Enter the number of run units via Setup screen > Group Control > Number of Run Units (P083)

5.3.4 Group Control—Start Sequence from Power Up

1. Power is available when the controller is active.
2. POST (power on system test) and Firmware initializes in less than 1 second—CANbus network activity and RS485 communications with inverters will be established within the 1 second period.
3. When the controller is initialized, it looks for messages from the other CDU 600s in the Group. Messages from CDUs are transmitted asynchronously every 100 milliseconds, so within 200 milliseconds messages will have been exchanged and the group demand shared.
4. When the group demand is shared, the inverters will be driven to the group demand instantly via RS485 Modbus RTU communication from the controller.
5. The inverters are programmed with a 2 seconds ramp up period (2 seconds to 100%), so if the group demand is typically at 65% to 75%, ramp up will take 1.5 seconds. This ramp up period is designed to prevent a secondary discharge pressure over shoot on CDU 600 (or pump) re start. It is also configurable via the F002 Acceleration Time parameter on the inverter.
6. Total startup time in Group Control mode is 1 second +200 milliseconds + 1.5 seconds = 2.7 seconds to the required pump speed, pressure, and flow rate.

5.3.5 Group Control—Controls

When in group control, the lead CDU 600 modulates its pump speed to maintain a differential pressure setpoint. The differential pressure setpoint default is an average over all the individual running CDU 600 differential pressure readings. This can be changed to the differential pressure over all CDU 600s in the group in Setup/Group Control/P094 regardless if they are running. All CDU 600 units work in parallel and set their pump speeds to be identical with that of the lead CDU 600.

Each CDU 600 modulates its own primary (facility) fluid control valve to maintain a group wide IT supply fluid temperature setpoint. Each CDU 600 also locally regulates temperature using the average of its individual temperature sensors.

5.3.6 Group Control—Unit Rotation and Standby Units

Unit rotation can be configured to be weekly, monthly, or never in the Setup screen under Group Control. Upon rotation, one of the standby units is switched on and one of the duty units is switched off. For example, if units 1, 2, 3, and 4 are running and 5 and 6 are off, after rotation units 2, 3, 4, and 5 will run while 1 and 6 off.

In the event that the load exceeds the capacity of the running units and there are standby units, the standby units will not kick in automatically. The configured number of duty units is selected based the max load. If this max load increases, then additional load has been added and the operator should increase the configured number of duty units.

5.3.7 Group Control—Failover Offset

Failure mode enables standby CDU pumps to start in 75 ms and a 2 seconds ramp up when a XDU1350 in the group is taken offline. This is to seamlessly maintain system differential pressure if a unit is lost without over/undershoots.

The failure offset is applicable only when a group of 3 or more CDU 600 units are configured in N (that is all CDU 600s set to run, with no CDU 600 redundancy) and they are configured to spin up the standby pump when an CDU 600 failure/power off occurs. The pump reduction (or failure) offset is applied to the system pump speed when there is a CDU 600 failure (that is shutdown) or the unit is switched off. Spinning up the standby pumps in the running CDU 600 will result in more pumps running than when all CDUs are healthy and operational. To avoid spikes in differential pressure, P217 failure pump speed reduction is applied to the system pump speed at the time of the CDU failure. P217 should be determined at commissioning.

5.3.8 Group Control—Failure Modes

When there is communication failure between units, a new lead CDU 600 will be established for each new grouping of units. When communication is re-established, the original lead XDU1350 will take control. See **Figure 5.9** on the facing page. If only the lead CDU 600 loses communication, the next CDU 600 will take over the lead role. When the previous lead CDU 600 communication is re-established, it will not take over the lead role again. See **Figure 5.10** on the facing page.

Figure 5.9 General Communication Failure

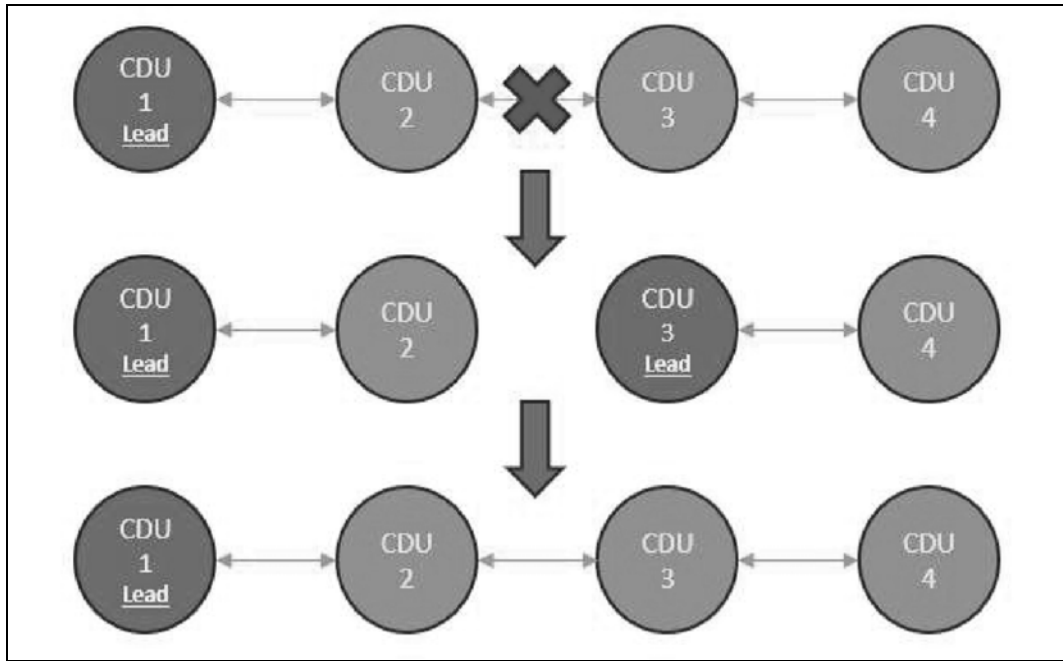
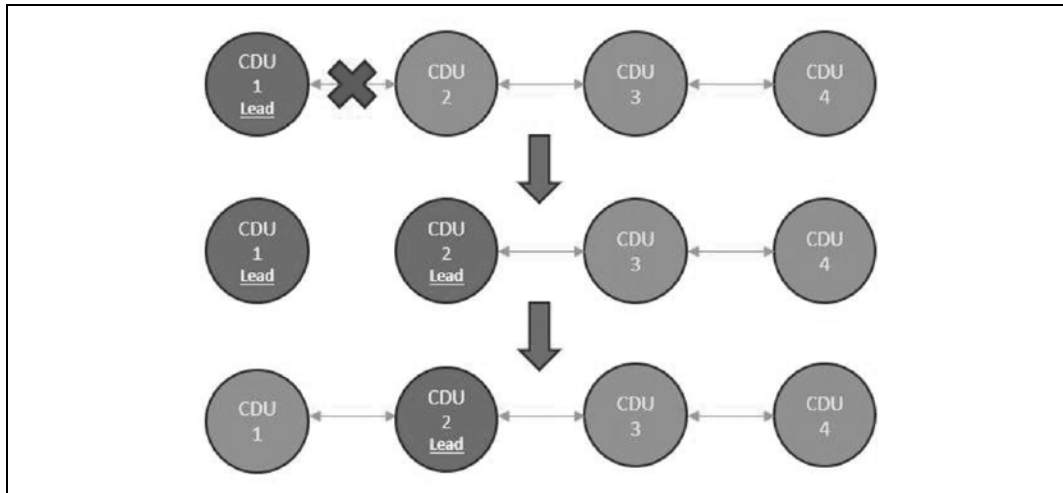

Figure 5.10 Lead Communication Failure



In the event of a sensor failure, all sensors related to control (PS1, PS2 and T2) are redundant at the CDU 600 level, so a single sensor failure will not impact the operation or the status of the CDU 600, So, if the lead CDU 600 does have a sensor failure it will not result in a change of lead.

This page intentionally left blank

6 Maintenance

6.1 Fluid Specifications



CAUTION: Risk of improper piping installation, leak checking, fluid chemistry and fluid maintenance. Can cause injury. Building and equipment damage may also result. Installation and service of this equipment should be done only by qualified personnel who have been specially-trained in the installation of air-conditioning equipment and who are wearing appropriate, OSHA-approved PPE.

NOTICE

Risk of leaking water/coolant fluid lines. Can cause equipment and building damage. Lines and joints must be inspected regularly. Improper installation, application, and service practices can result in water/coolant leakage from the unit. Water/coolant fluid can result in fluid leakage, severe property damage and loss of critical data center equipment. Do not locate unit directly above any equipment that could sustain water damage. Vertiv recommends installing monitored leak detection equipment for the unit and supply and return lines.

NOTICE

Risk of no flow condition. Can cause equipment damage. Do not leave the water/coolant fluid supply circuit in a no flow condition. Idle fluid allows the collection of sediment that prevents the formation of a protective oxide layer on the inside of the tubes. Keep unit switched On and water/coolant fluid supply circuit system operating continuously. In multiple unit teams, allow standby units to enter the rotation automatically or schedule regular manual rotations.

NOTICE

Risk of piping system corrosion and freezing fluids. Can cause leaks resulting in equipment and very expensive building damage. Heat exchangers and piping systems are at high risk of freezing and premature corrosion. Automotive antifreeze is unacceptable and must NOT be used in any fluid system. Use only coolant fluid solution that meets the requirements of recommended industry practices. Do not use galvanized pipe.

The system coolant fluid must be analyzed by a competent fluid treatment specialist before start up to establish the inhibitor and antifreeze solution requirement and evaluated at regularly scheduled intervals throughout the life of the system to determine the pattern of inhibitor depletion.

The fluid complexity and variants of required treatment programs make it extremely important to obtain the advice of a competent and experienced fluid treatment specialist and follow a regularly scheduled coolant-fluid system-maintenance program.

Fluid chemistry varies greatly as do the required additives, called inhibitors, that reduce the corrosive effect of the fluids on the piping systems and components.

The chemistry of the coolant fluid used must be considered, because some sources may contain corrosive elements that reduce the effectiveness of the inhibited formulation. Sediment deposits prevent the formation of a protective oxide layer on the inside of the coolant system components and piping. The coolant fluid must be treated and circulating through the system continuously to prevent the buildup of deposits and/or growth of sulfate reducing bacteria. Proper inhibitor maintenance must be performed to prevent corrosion of the system.

Consult fluid manufacturer for testing and maintenance of inhibitors.

Commercial grade coolant fluid is generally less corrosive to the common metals of construction than water itself. It will, however, assume the corrosivity of the coolant fluid from which it is prepared and may become increasingly corrosive with use if not properly inhibited.

Vertiv recommends installing a monitored fluid-detection system that is wired to activate the automatic closure of field installed coolant fluid supply and return shut off valves to reduce the amount of coolant fluid leakage and consequential equipment and building damage. The shut off valves must be sized to close off against the maximum coolant fluid system pressure in case of a catastrophic fluid leak.

- **Primary circuit:** The CoolChip CDU 600 is designed for use with a facility supply of water or up to 20% glycol/water. A 20% glycol concentration will give protection to approximately -9°C (16°F). If a higher concentration of glycol is used, then the cooling capacity of the unit may have to be de-rated. Contact Vertiv for advice.
- **Secondary circuit:** The secondary circuit should be filled either be PG-25 heat transfer fluid or particulate free deionized water treated with suitable corrosion inhibitors and biocides for the cooling application.

Failure to use adequate fluid treatment may result in decreased system performance and reliability due to corrosion, scaling, fouling and microbiological growth which may invalidate the warranty.

6.2 Planned Preventative Maintenance

Planned maintenance services should be carried out every 6 months following installation and commissioning.

6.2.1 Special Tools and Equipment

- Surface temperature measurement device
- Air temperature measurement device
- Clamp-on ammeter
- Drain tube (supplied with unit)
- Fluid sample kit (for fluid analysis)
- Micro-SD card reader and computer

6.2.2 Visual Checks for Damage and Leakage

- Pipework and hoses
- All temperature, level, flow, and pressure sensors
- Expansion vessels and Schrader valves
- Auto air vents and screw caps
- Drain valves
- Pumped clamped connections
- Pipe clamped connections
- Heat exchange pipework and connections
- Check running pump for abnormal noise
- Record any damage to unit

6.2.3 General Settings

- Record unit serial number on maintenance check lists
- Record values from controller display home page

6.2.4 Controller Checks

These checks look at setpoints, alarm actions, and group control.

- Check the sync date and time of the units (NTP may or may not be enabled).
- Check for any current alarms and take appropriate action as detailed within this manual.
- Download the complete contents of the folder with the name of product and serial number from the micro-SD card. This folder contains historic alarm log, system log, parameter log, and data log files.
- Record parameters from the parameter log file that have changed from default since commissioning. These are signified by an asterisk adjacent to the parameter ID in the log file. Verify with the customer why values have changed since commissioned value.

6.2.5 Sensor Checks

- Check all fluid and ambient temperature/humidity sensors consistent with surface and air temperature measurement device readings.
- Check pressure and flow sensor readings are consistent with other units in the group (if multiple units) and with commissioned values.

6.2.6 Fluid Checks

- Take secondary circuit fluid sample as directed by fluid management partner and send to approved lab for analysis and report recommendations.
- Take action on any previous fluid report recommendations.
- Check supplementary filling operation and manual override if not automatically engaged when taking fluid sample.
- Check makeup reservoir tank is full, properly connected, and that the breather cap is functional.
- Record secondary fluid filter DP readings (PS5a and PS5b difference with PS2).
- Isolate and clean fluid filter(s) if necessary, and record new readings.

6.2.7 Functional Checks

Functional checks may require unit shut down.

- Check controller and display firmware status and upgrade if necessary.
- Carry out audible/visual checks on operational pump.
- Override operational pump speed to 100% and record temperature, current, and voltage.
- Override primary control valve to 100% and note feedback signal corresponds.
- Check all cable connections and terminals for signs of damage or loose wire connections.
- Check for the fan running status on the EP and ATS.

6.3 Primary Filter Service (if Fitted)

The primary filter may be removed and cleaned while the unit is running. Follow this procedure:

1. Open bypass valve A to position as shown in **Figure 6.1** below.
2. Close filter isolation valves B and C to positions shown in **Figure 6.1** below.
3. Open the air vent on top of the filter elbow.
4. Drain fluid from the filter housing using drain valve and drain hose on underside of filter.
5. Once drained, under the clamp ring, then withdraw the cap and filter screen using the T handle provided
6. After the fluid is drained, undo the clamp ring. Withdraw the cap and filter screen using the T handle provided out through the front of the unit.
7. To clean the filter, rinse with DI water or PG solution and then let drip dry.
8. Replace by reversing this procedure. Ensure that the drain valve is closed first before re-opening valves B and C and closing valve A.

Also for the detailed view of component location, refer to [Submittal Drawings](#) on page 77.

Figure 6.1 Servicing the Primary Filter—Section View from Left Side of Unit

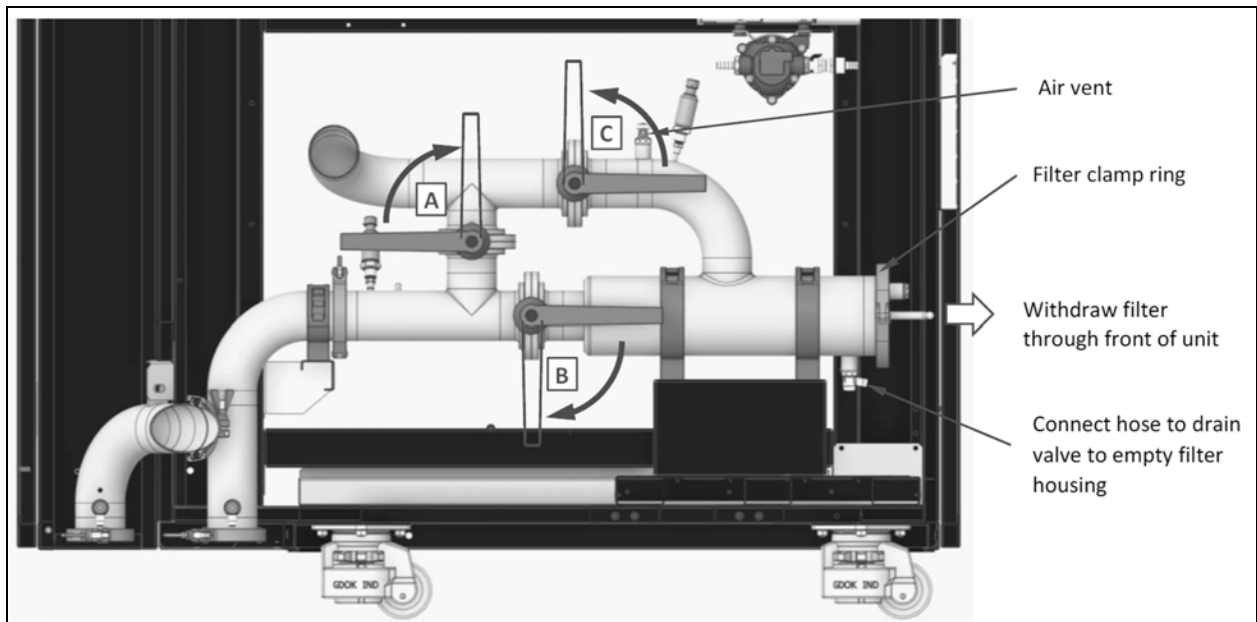

6.4 Secondary Filter Service (if Fitted)

NOTICE

This procedure should be carried out by a trained individual or a member of the Vertiv Services team.

The control panel may be hinged up 90° on gas struts to give improved access to service the secondary filters. See **Figure 6.2** on the facing page. Also for the detailed view of component location, refer to [Submittal Drawings](#) on page 77.

IMPORTANT! If the control panel does not move, then the transit retaining bolts were not removed during the installation process. Refer to [SL-07625 CoolChip CDU 600 Installation and Commissioning](#).

To remove these bolts now requires the unit to be shutdown and power removed by using the isolator/disconnect switch to open the power section door of the control panel and gain access to these bolts.

Figure 6.2 Hinging Up Control Panel

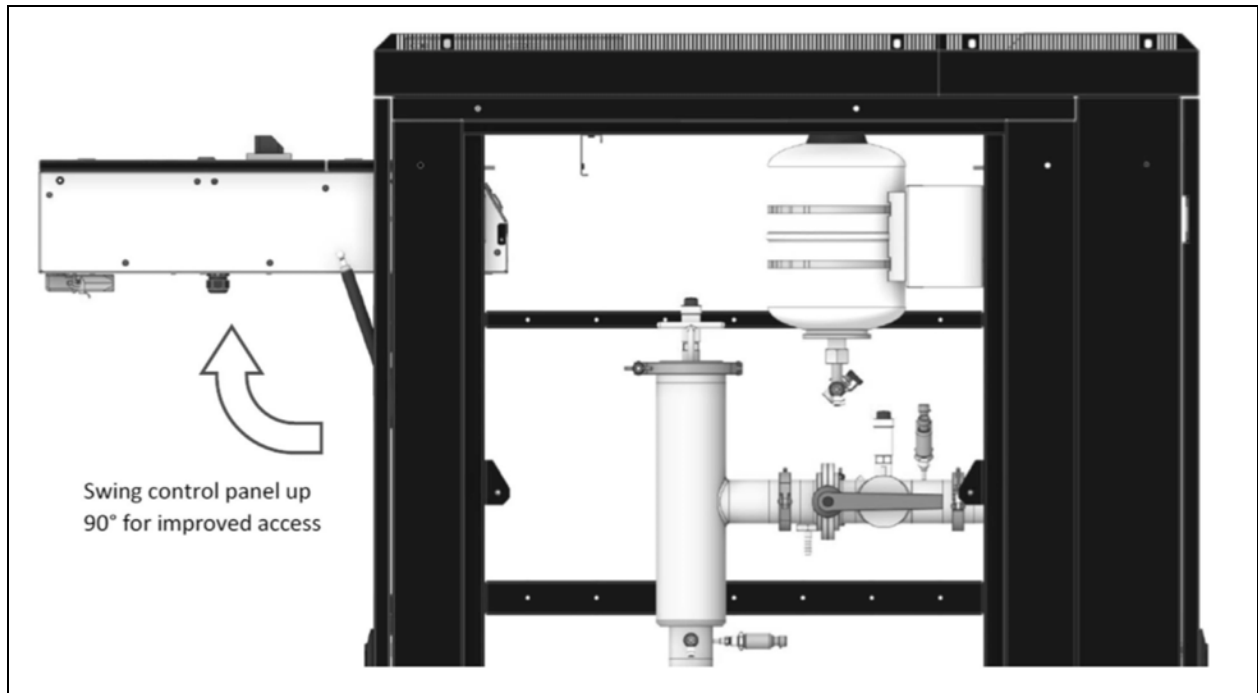

Remove and clean the secondary filters using this procedure:

IMPORTANT! If the unit is a single pump unit, then the CDU must be stopped before cleaning the filter. If the unit has twin (redundant) pumps, then the filters can be cleaned while the unit is running, provided that operation is switched to the pump/filter not being cleaned. Place the pump supplying the filter to be cleaned into the out of service state via the Service menu.

Turn OFF the entire unit if it is possible, this allow for the simultaneous cleaning of all installed filters.

Other wise proceed as follows:

1. Enter the HMI display with Service Password and navigate to Service → Secondary Pumps → Pump 1,2 or 3 (number of pumps present depends on the unit configuration). See **Figure 6.3** on the next page.

Figure 6.3 Navigating to Secondary Pump(s)

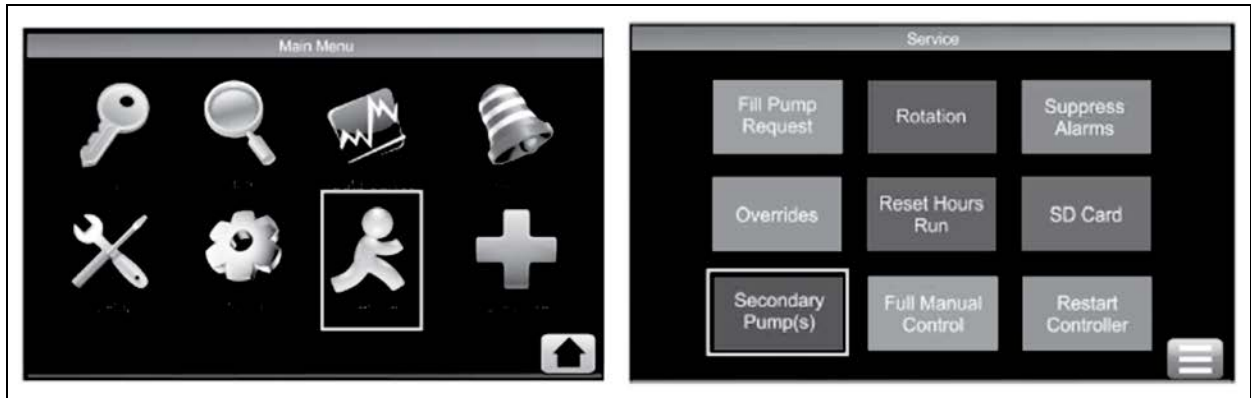

2. Set the pump present in the filter line to be cleaned (Pump 1, 2, or 3, it depends on the unit configuration) into Service mode through the HMI unit controller. This will ensure the pump will not be operational during the filter cleaning activity.

Figure 6.4 Service - Secondary Pump Service Status

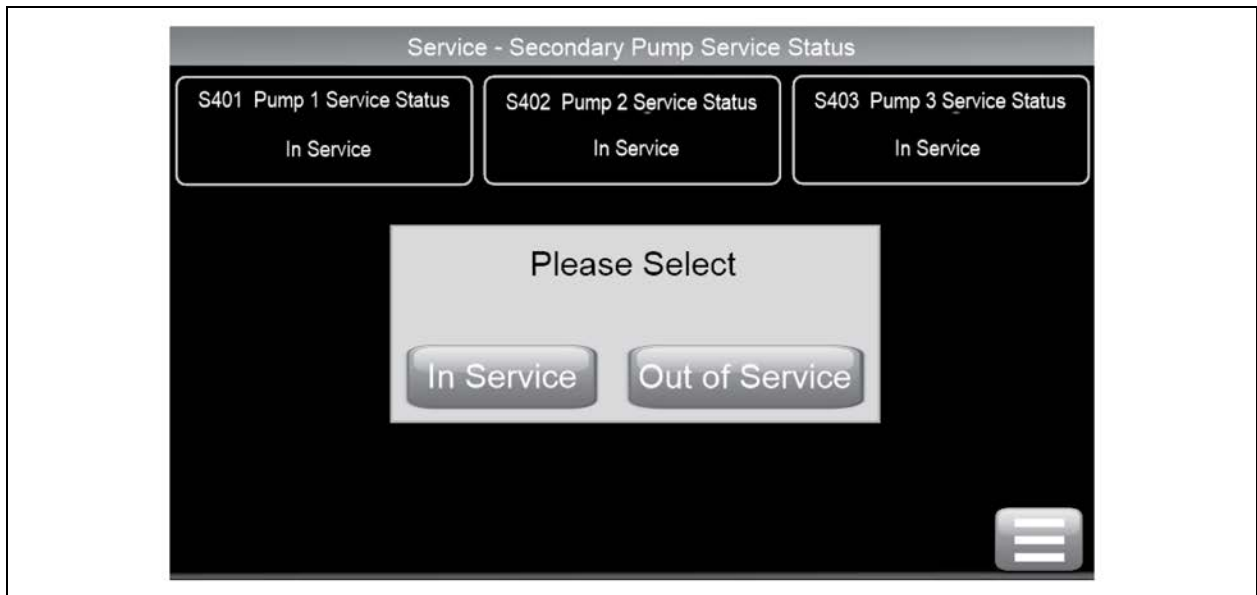

3. Hinge up the control panel as shown in [Servicing Secondary Filters](#) .
4. Close the filter isolation valves A and B to positions shown in **Figure 6.5** on the facing page.
5. Drain a cupful of fluid from the filter housing using the drain valve and drain hose at the base of the filter housing. It is not necessary to completely drain the filter housing before removing the filter screen.
6. After draining some fluid, undo the clamp ring at the top of the filter housing. Withdraw the cap and filter screen using the T handle provided. Once clear of the filter housing, the filter screen can be brought through the front door of the unit out through the roof of the unit.
7. To clean the filter, rinse with DI water or PG solution and then let drip dry.

Figure 6.5 Servicing Secondary Filters

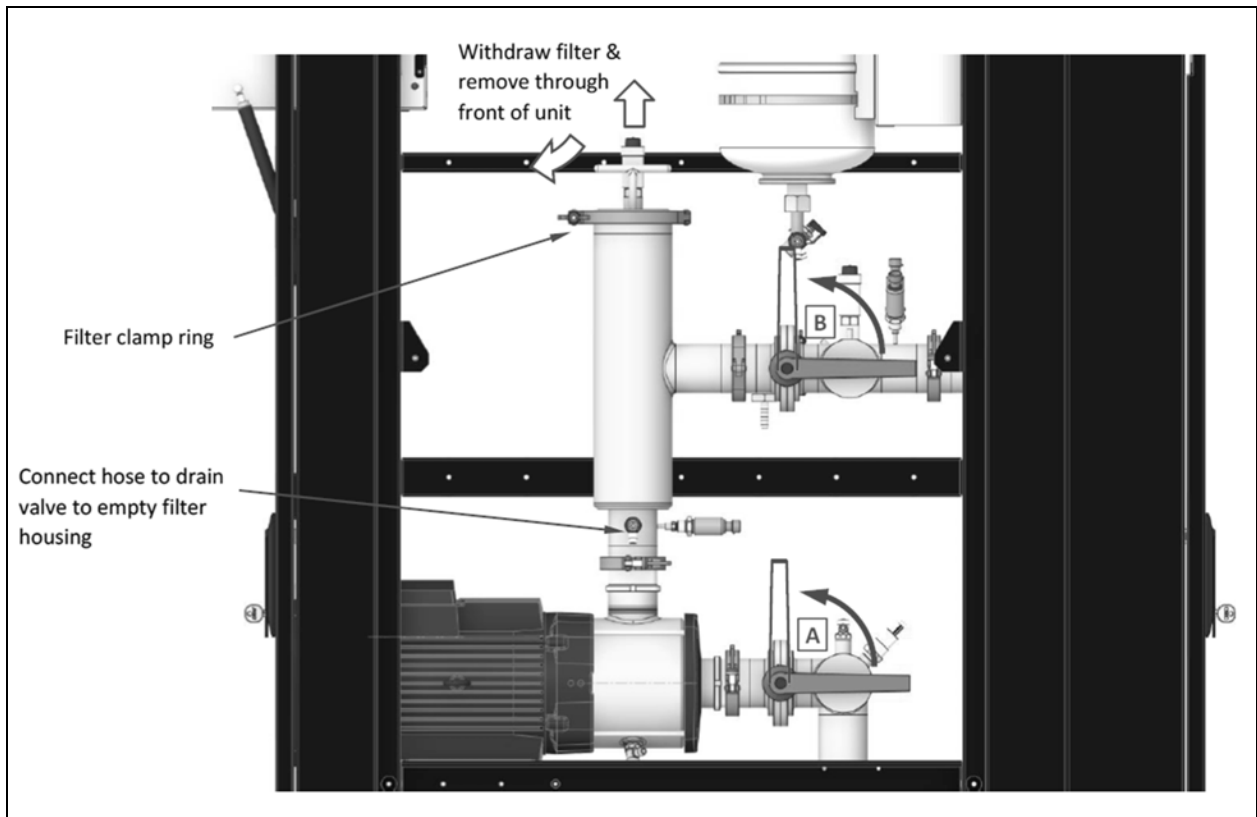

8. Replacement is the reverse of the procedure. Ensure that the drain is closed before opening valves A and B. Ensure that additional fluid is available to replenish the makeup reservoir if necessary.

When opening the valves, crack open valve A initially until all contained air is purged out of the filter housing through the automatic air vent. Then fully open valve A and then open valve B. When valve A is opened, the loss of system pressure should automatically start the fill pump P3 to fill the filter housing and bring the system back to operating pressure.

6.5 Unit Draining

Drain valves are provided throughout the Vertiv™ CoolChip CDU 600 to permit the removal of system fluid for filter change and other service work. Field supplied external isolation valves should be fitted by the installer to both supply and return pipes, as close as possible to the Vertiv CoolChip CDU 600 for maintenance purposes.

If the unit requires draining for service or maintenance, contact Vertiv.

Figure 6.6 Drain Valve

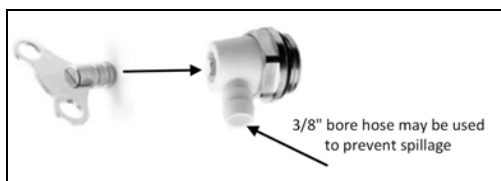

Primary circuit drain valve locations:

- 1 on underside of filter housing (if fitted)
- 1 on supply tail pipe (top or bottom exit)
- 1 on return tail pipe (top or bottom exit)

Secondary circuit drain valve locations:

- 1 in base of each pump
- 1 at base of each filter inlet
- 1 in supply tail pipe (bottom exist only)
- 1 in return tail pipe (top of bottom exit)
- 1 in return manifold pipe (if fitted) to heat exchanger

Appendices

Appendix A: Technical Support and Contacts

A.1 Technical Support/Service in the United States

Vertiv Group Corporation

24x7 dispatch of technicians for all products.

1-800-543-2378

Liebert® Thermal Management Products

1-800-543-2378

Liebert® Channel Products

1-800-222-5877

Liebert® AC and DC Power Products

1-800-543-2378

A.2 Locations

United States

Vertiv Headquarters

505 N Cleveland Ave

Westerville, OH 43082

Europe

Victor-von-Bruns Strasse 21,

8212 Neuhausen am Rheinfall, Switzerland

Asia

7/F, Dah Sing Financial Centre

3108 Gloucester Road, Wanchai

Hong Kong

This page intentionally left blank

Appendix B: Submittal Drawings

Submittal drawings referenced in this document are listed below and are presented in the order as mentioned within this document on the following pages.

Table B.1 Submittals

Submittal Number	Title
20000180	Vertiv™ CoolChip CDU 600 Component Location Diagram with SS make up tank
20000033	Vertiv™ CoolChip CDU 600 Cabinet Dimensional Data
20000043	Vertiv™ CoolChip CDU 600 Piping Schematic with SS make up tank

COOLCHIP CDU

COMPONENT LOCATION DIAGRAM XDU0600 Unit with Stainless Steel Reservoir

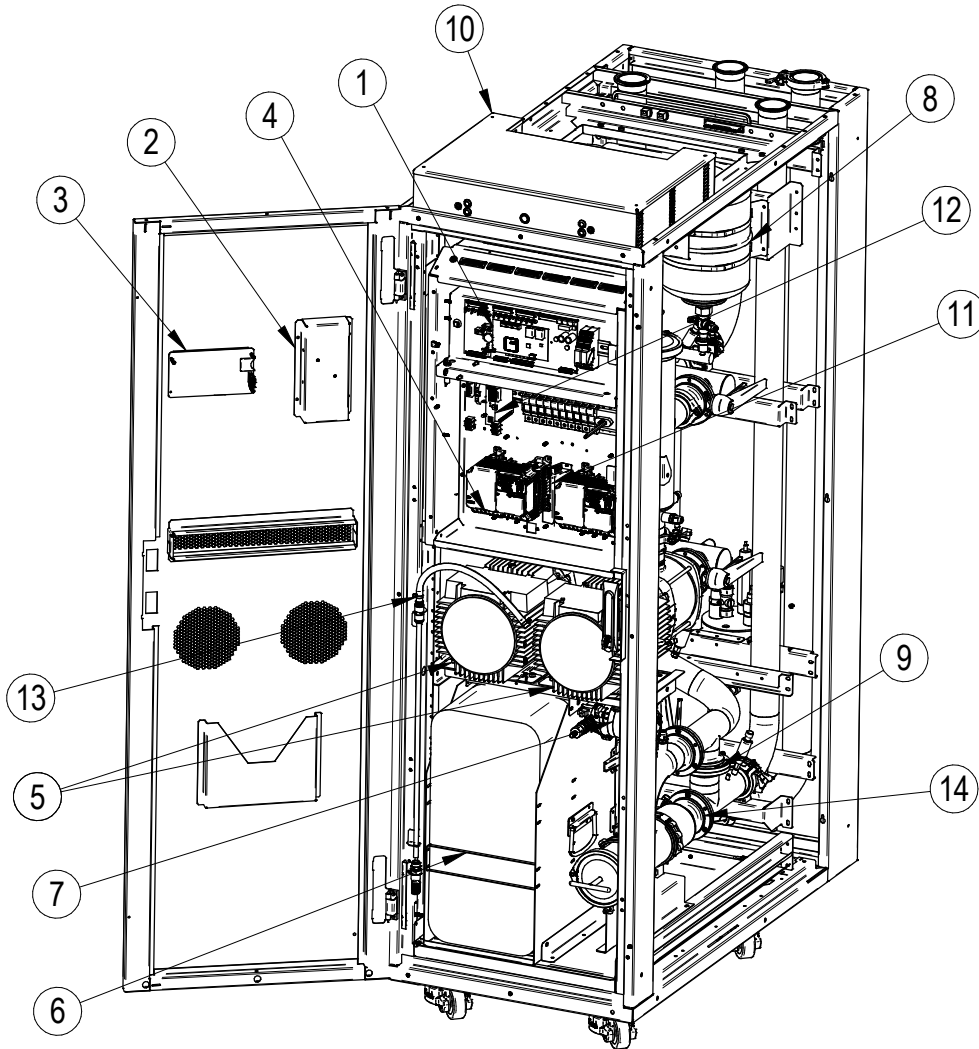

FRONT OF UNIT (WITHOUT PANELS)

Item	Description
1	Controller / processor board
2	Room temperature / humidity sensor
3	Controller touch screen (mounted to front door)
4	Pump inverter drive
5	Secondary pumps
6	Plate heat exchanger
7	Reservoir Fill Pump P4

Item	Description
8	Expansion vessels
9	Primary filter bypass valve
10	Power Termination Enclosure/ATS (Optional)
11	EMC Filters (Optional)
12	DC Power Supply
13	Filling Wand
14	Primary Filter

COMPONENT LOCATION DIAGRAM XDU0600 Unit with Stainless Steel Reservoir

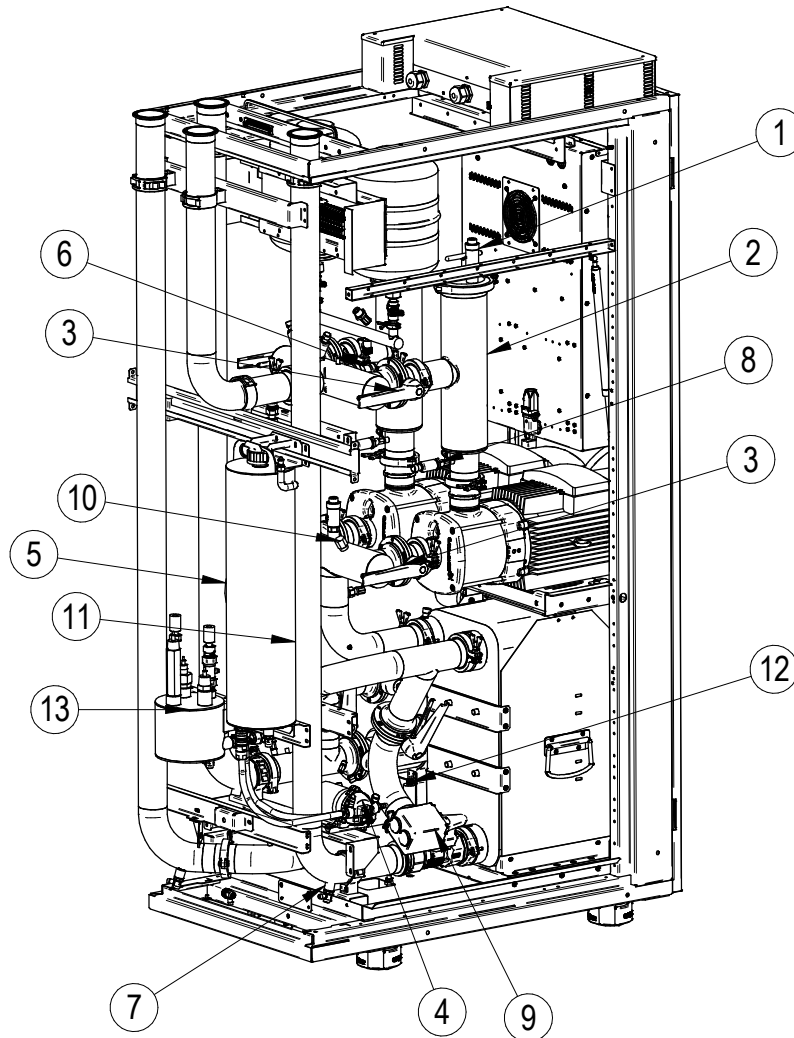

REAR OF UNIT (WITHOUT PANELS)

Item	Description
1	Auto Air Vents
2	Secondary Filters (Optional)
3	Filter/Pump Isolation Valves
4	System Fill Pump P3
5	10 L Reservoir Tank (Optional)
6	Pressure Relief Valve
7	Drain Valve

Item	Description
8	Pressure Sensor
9	Three Way Valve
10	Level Sensor
11	Primary Flow Meter
12	Secondary Flow Meter
13	Secondary Fluid Monitoring Package (Optional)

CABINET DIMENSIONAL DATA

XDU0600 Unit

Recommended minimum clearance for component access 24 inch X 24 inch (600mm X 600mm)

Recommended minimum clearance for component access 24 inch X 24 inch (600mm X 600mm)

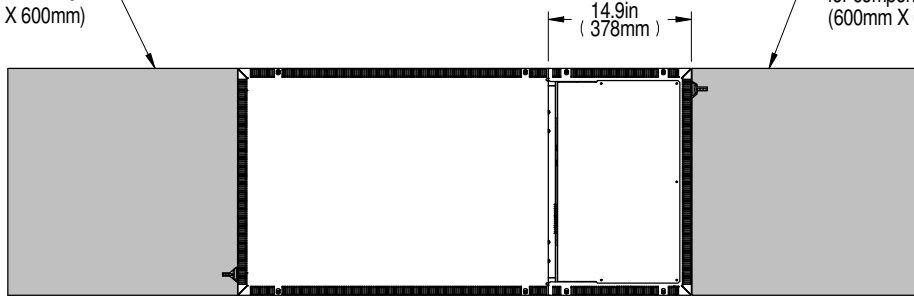

Top of Unit

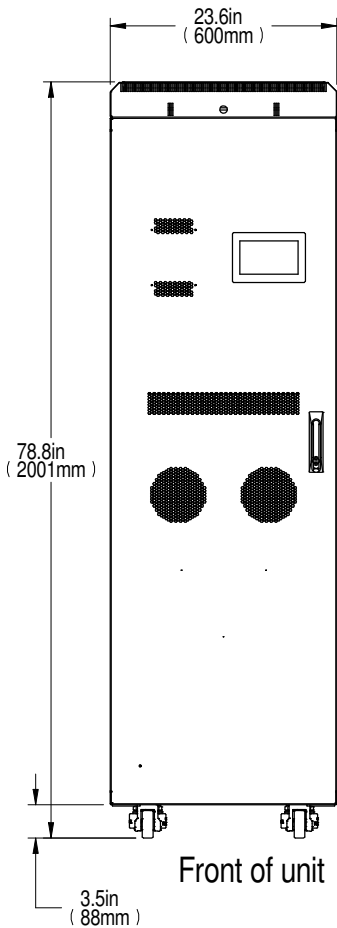

Front of unit

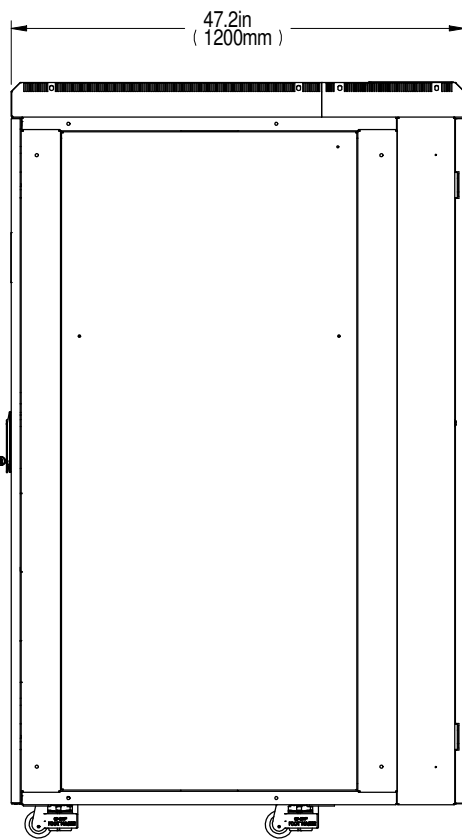

Right Side of Unit

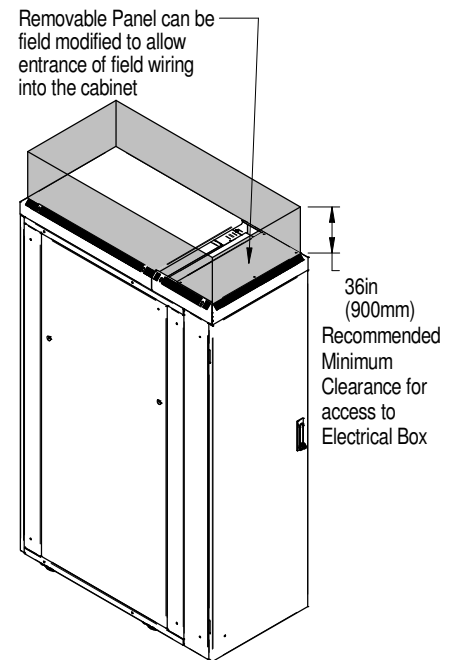

Rear of Unit

Note:-

1. Overall unit dimensions tolerance is ± 0.1 in (5mm).

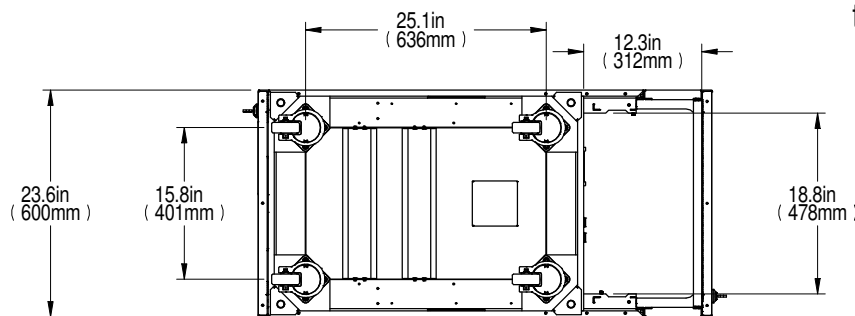

Bottom of Unit



COOLCHIP CDU

CABINET DIMENSIONAL DATA XDU0600 Unit

WEIGHT & SHIPPING DIMENSION TABLE

Unit Weight						
Base Unit	Dry Weight		Operating Weight		Shipping	
	lbs.	kg	lbs.	kg	lbs.	kg
	1058	480	1213	550	1390	630
Shipping Dimensions						
Base Unit	Width		Depth		Height	
	in.	mm	in.	mm	in.	mm
	39.37	1000	51.18	1300	88.19	2240

NOTE: ADDITIONAL WEIGHT OF UNIT WITH ATS - 2KG

Note:-
1. Overall unit dimensions tolerance is ± 0.1 in (5mm).

COOLCHIP CDU

PIPING SCHEMATIC XDU0600 Unit with SS Reservoir

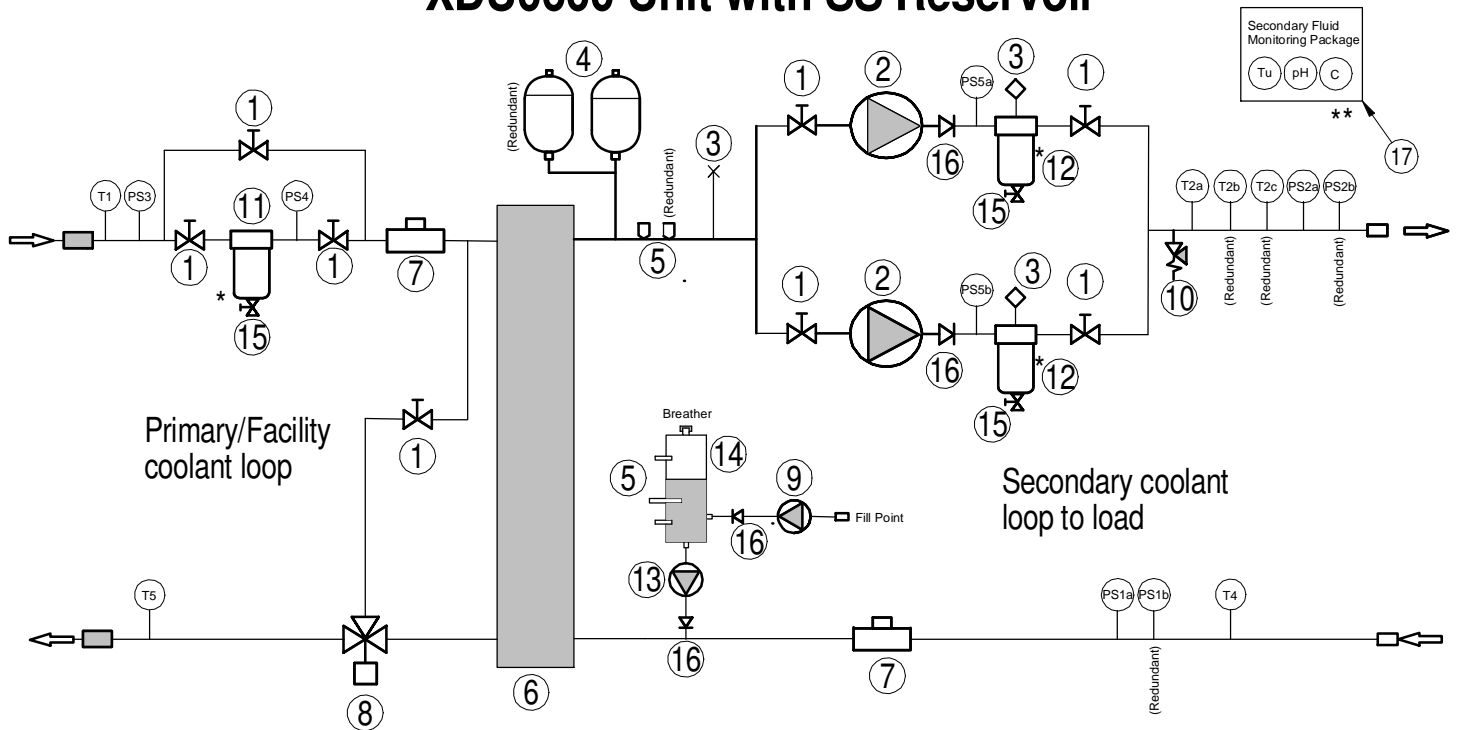

Item	Description	Item	Description
1	Shut Off Valve (Typical)	10	Pressure Relief Valve
2	VFD Pump (Qty 2)	11	Primary Filter
3	Auto Air Vent (Typical)	12	Secondary Filter
4	Expansion Tank (Qty 2)	13	System Fill Pump P3
5	Water Level Sensor	14	10 L SS Reservoir
6	Brazen Plate Heat Exchanger	15	Drain Valve
7	Flow Meter	16	Check Valve
8	3-way cooling control valve	17	Secondary Fluid Monitoring Package
9	Reservoir Fill Pump P4		

————— Factory Piping

 Temperature Sensor

 Pressure Sensor

* Optional factory installed primary/secondary strainer(s)

** Optional Secondary Fluid Monitoring System (Refer Document No. 10082419)

NOTES:

- Arrangement Diagram representation shown. Do not use for specific connection locations.
- For each CoolChip CDU unit, a separate 500 micron filter is required in the chilled water supply from the chilled water source. The filter is field supplied and installed. The maximum distance of the filter is 10 feet from the CoolChip CDU.
- At minimum, a field installed 500 micron filter is required in the secondary return line to Vertiv CoolChip CDU. Vertiv recommends bypass piping arrangement to allow for cleaning the strainer without disrupting unit operation. Also, pressure taps across the strainer to check pressure drop. Three full port ball valves and piping are supplied by the field. The maximum distance of this assembly is 10 feet from the Vertiv CoolChip CDU Unit.
- Unit isolation valves are required in the field piping of facility and secondary fluid connections to facilitate service. The isolation valves are field supplied and installed.
- Internal CDU pipework is not load bearing.
- Engineer of record must provide external support structure to attach/secure and support all field piping external to the CDU.

This page intentionally left blank

Appendix D: Disposal Procedure

Waste materials must be disposed of in a responsible manner in line with environmental regulations.

Decommissioning and disposal of this product should be undertaken by qualified personnel in adherence to local and national safety regulations, particularly for protection of lungs, eyes, and skin from chemicals, dust etc. Approved lifting gear and power tools should be used and access to the work area must be restricted to authorized personnel. The following steps are a guide only and should be adjusted to take into account local site conditions:

1. Disconnect unit from electrical supply.
2. Drain and dispose of any heat transfer fluid through an approved recycling facility.
3. Remove unit to an approved recycling facility.

This page intentionally left blank

Connect with Vertiv on Social Media



<https://www.facebook.com/vertiv/>



<https://www.instagram.com/vertiv/>



<https://www.linkedin.com/company/vertiv/>



<https://www.x.com/Vertiv/>



Vertiv.com | Vertiv Headquarters, 505 N Cleveland Ave, Westerville, OH 43082 USA

©2026 Vertiv Group Corp. All rights reserved. Vertiv™ and the Vertiv logo are trademarks or registered trademarks of Vertiv Group Corp. All other names and logos referred to are trade names, trademarks or registered trademarks of their respective owners. While every precaution has been taken to ensure accuracy and completeness here, Vertiv Group Corp. assumes no responsibility, and disclaims all liability, for damages resulting from use of this information or for any errors or omissions.

SL-07626_REVD_06-26