

SYSTEM OVERVIEW

Description: 50 VDC @ up to 132 kW (Up to eight (8) shelves (4+4 Redundancy Configuration) can be configured in a single system)

The PowerDirect Rack 50 VDC Power System Model PSS5033 50 VDC Power System is an integrated power system containing a power shelf, Power Supply Units (PSU), and Power Monitoring Module (PMM). Refer to Figure 1 for a system overview illustration.

- **Power Shelf**

The power shelf houses up to six (6) PSUs. Each shelf in the system also houses a PMM. Up to eight (8) shelves (4+4 Redundancy Configuration) can be configured in a single system. The shelf is designed to be compatible with the Open Compute ORV3 HPR rack design.

- **System Controller**

The Power Monitoring Module (PMM) provides monitoring and control of the power supply units in the shelf and communicates upstream via Modbus over RS485. The PMMs from multiple shelves are connected together to comprise a single system communication link and to provide for load share of the PSUs across the entire system. Refer to the PMM User Manual (UM1PMM1S0) for more information.

- **Power Supply Units (PSUs)**

The system contains PSUs, which provide load power and battery recharge current (when applicable) during normal operating conditions. Refer to the Power Supply Unit Instructions (UM1R505500E4) for more information.

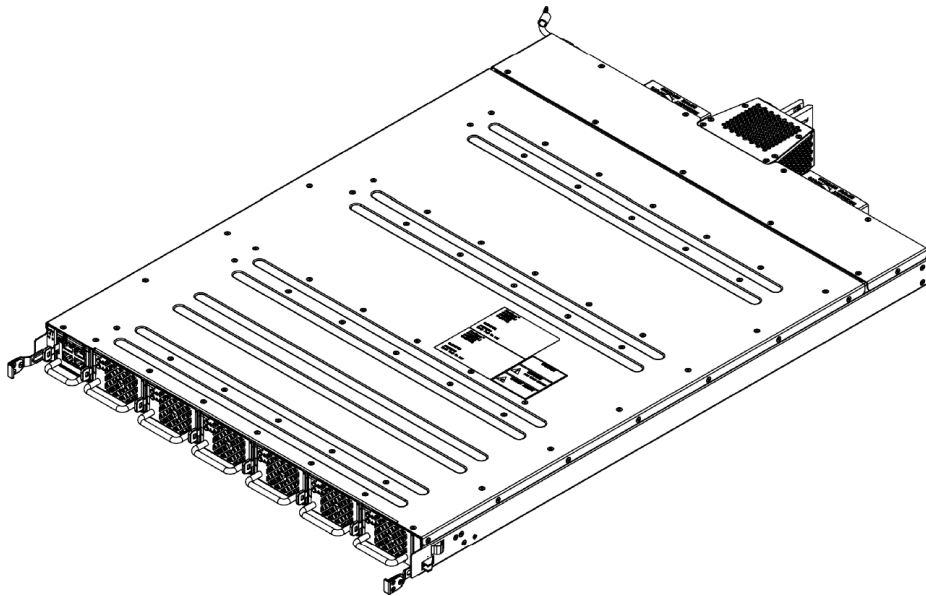

Figure 1
System Overview Illustration

PowerDirect 50 VDC Power System

System Application Guide

General Specifications

See detailed specifications on page 20.

Family:	Vertiv™ PowerDirect Rack
System Spec. No.:	1PSS5033
System Model:	PSS5033
System AC Input Ratings:	Nominal 200 VAC / 208 VAC / 220 VAC / 230 VAC / 240 VAC / 277 VAC, single phase, 50 Hz / 60 Hz, with an operating range of 200 VAC to 277 VAC. Nominal 400 / 230 VAC, 415 / 240 VAC, 480 / 277 VAC, 3W+N+PE, three phase, 50 Hz / 60 Hz. Nominal 208 VAC, 3W+PE, three phase, 50 Hz / 60 Hz. Nominal input frequency range is 50 Hz to 60 Hz.
System DC Input Ratings:	Nominal 240 VDC to 380 VDC
System DC Output Ratings:	Nominal 50 VDC @ 33 kW, negative ground. Output voltage is adjustable from 49 VDC to 51 VDC via the associated controller.
1R505500E4 PSU Rating:	See UM1R505500E4
System Agency Approval:	UL62368-1
Framework Type:	21" mounting frame of a version 3 HPR OCP (Open Compute Project) rack (see "Overall Dimensions – SAG PSS5033 List 01" on page 21).
Mounting Width:	537 mm (21.1 inches), nominal
Mounting Depth:	720 mm (28.3 inches)
Access:	Front and Rear for operation, installation and maintenance
Expansion Assembly Available:	None (up to eight standard shelves can be configured in a single system)
Control:	Microprocessor
Color:	Front panels are black, and the shelf is galvanized steel.
Environment:	-20 °C (-4 °F) to +45 °C (+113 °F) with full power performance. +45 °C (+95 °F) to +65 °C (+149 °F) with derating output.

TABLE OF CONTENTS

SYSTEM OVERVIEW 1

TABLE OF CONTENTS 3

MAIN COMPONENTS ILLUSTRATION 4

 1PSS5033 4

SYSTEM DESCRIPTIONS..... 5

 Power Shelf 5

 Input Cable Assembly Options..... 6

 Controller 11

 Power Supply Unit (PSU)..... 11

ACCESSORY DESCRIPTIONS 11

 PSU Mounting Position Blank Cover Panel, P/N 10162462..... 11

 User Replaceable Components..... 12

RECOMMENDED WIRING SIZES, BRANCH CIRCUIT PROTECTION, CRIMP LUGS, AND WIRING ILLUSTRATIONS 13

 Power Shelf Frame Grounding Requirements 13

 Power Shelf AC Input Connections..... 14

 Power Shelf DC Output Connections 18

 Controller Front Panel RJ45 Connectors 19

SPECIFICATIONS..... 20

1. SYSTEM 20

 1.1 System DC Output Ratings..... 20

 1.2 System Input Ratings 20

 1.3 System Environmental Ratings..... 20

 1.4 System Compliance Information 20

 1.5 Local Controls and Indicators 21

MECHANICAL SPECIFICATIONS 21

 Overall Dimensions - SAG PSS5033 List 01 21

 Weights..... 22

RELATED DOCUMENTATION 22

MAIN COMPONENTS ILLUSTRATION

1PSS5033

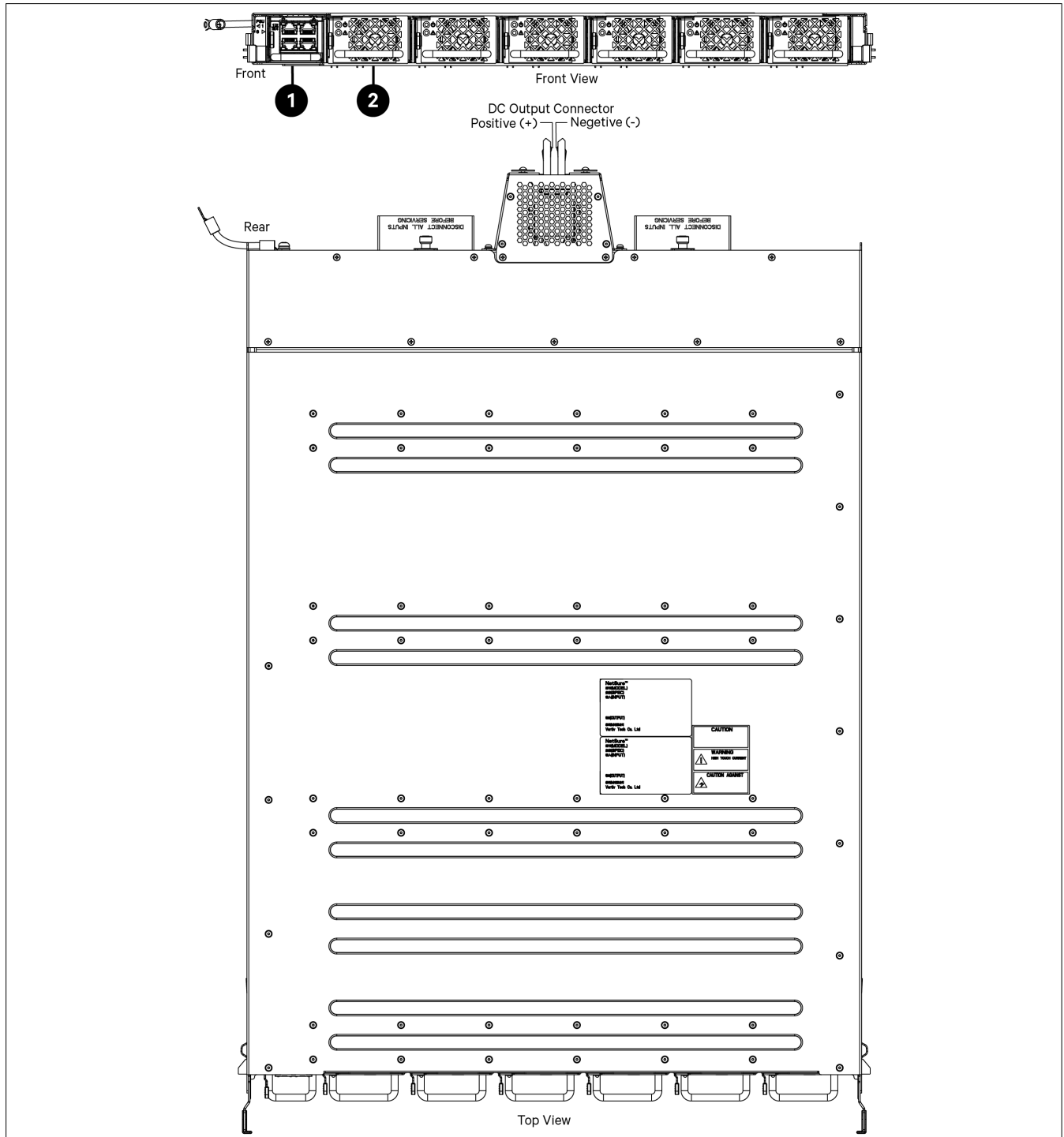

Item	Description
1	Controller (P/N 1PMM1S0)
2	6 x Power Supply Unit (PSU) (P/N 1R505500E4)

Figure 2
Main Components Illustration

SYSTEM DESCRIPTIONS

Power Shelf

P/N 1PSS503321N2

Features

- ◆ Consists of a 1 OU high by 21" wide shelf.
- ◆ Contains a system controller mounting slot.
- ◆ Contains six (6) power supply unit (PSU) mounting slots.
- ◆ Provides for connection of two (2) AC and/or DC inputs. Each AC and/or DC input feeds three PSUs.
- ◆ Provides a DC output connector which is compatible with the vertical busbar arrangement in the Open Compute Project version 3 HPR rack.
- ◆ Mounts in an OCP (Open Compute Project) version 3 HPR rack.
- ◆ Provides two short network cables (P/N 528520).

Restrictions

Maximum power shelf capacity is 660 A @ 50 VDC.

Ordering Notes

- 1) Order as required (maximum of eight per system).
- 2) Order a controller P/N 1PMM1S0 for each shelf (see page 7).
- 3) Order up to a total of six (6) PSUs P/N 1R505500E4 per power shelf (see page 11).
- 4) Order a PSU mounting position blank cover panel (P/N 10162462) for each empty PSU mounting position in the system (see page 11).
- 5) Order two (2) input cable options per power shelf (see page 6).
- 6) Order two (2) long network cables (P/N 10174051) to connect between two shelves that are separated by more than 250 mm (9.84 inches).
- 7) Order one (1) mounting rail kit (P/N 10274006) per shelf, as required, to secure the shelf into an OCP version 3 HPR rack.

Input Cable Assembly Options

General

The power shelf provides connections for two (2) input feeds. Each feeds three PSUs.

Five (5) input cable options are available which provide an input cord of various lengths and mating connector. Wye/star and delta AC input configurations are supported.

Cable Assemblies with IEC 60309 530P6S Plug

Features

- ◆ Includes 5-wire AC input line cord. Factory connected at one end is a connector that plugs into a mating connector on the rear of the power shelf and on the other end with an IEC, 530P6S, 30 A / 32 A plug. See Figure 3.
- ◆ Available in various lengths.

Restrictions

Plug rated for 32 A.

Ordering Notes

- 1) Order two (2) as required for a 1PSS503321N2 shelf.
 - a) P/N 10284154 = 1.5 meters (4.92 feet) long
 - b) P/N 10284155 = 2.5 meters (8.20 feet) long
 - c) P/N 10284156 = 3.5 meters (11.48 feet) long
 - d) P/N 10284157 = 4.5 meters (14.8 feet) long
 - e) P/N 10284158 = 5.5 meters (18.0 feet) long
 - f) P/N 10284159 = 6.5 meters (21.3 feet) long

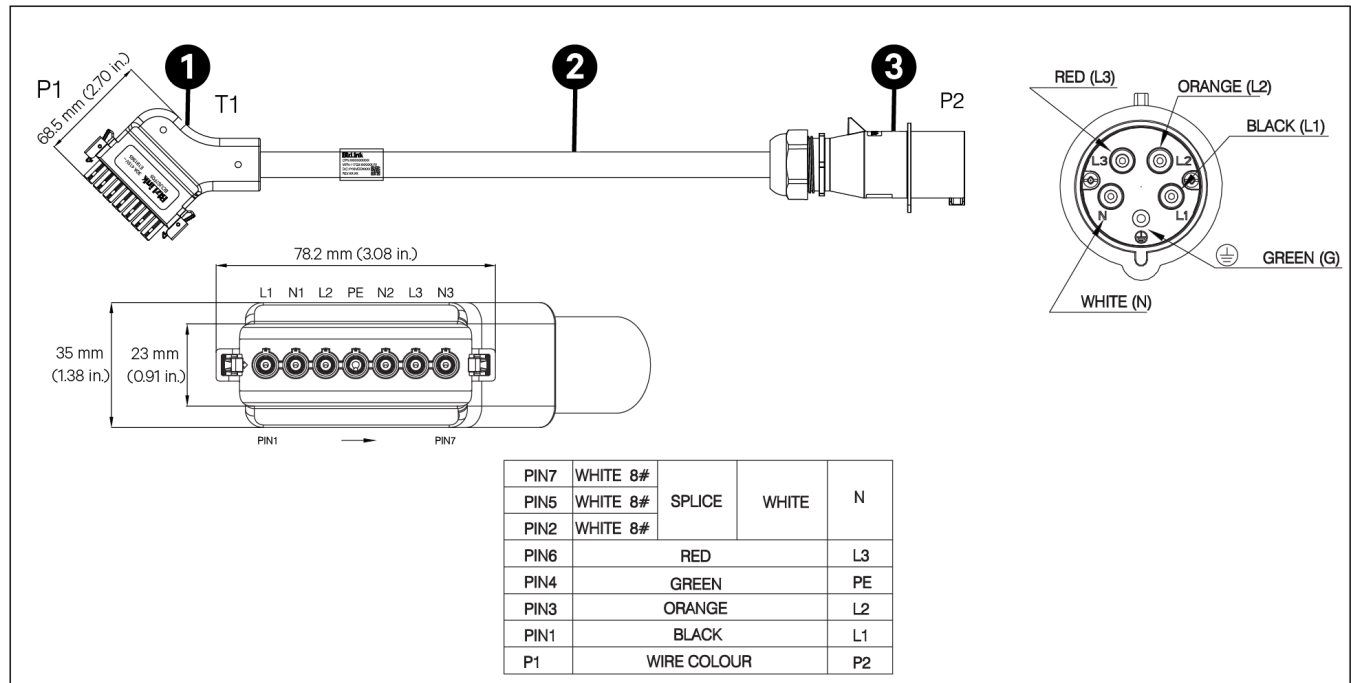

Item	Description
1	7 Pin Female Connector
2	TYPE SOOW 5C x 8 AWG Cable
3	IEC, 60309, 530P6S, 30 A / 32 A Plug

Figure 3
AC Input Cable Assembly IEC 60309 530P6S Plug

PowerDirect 50 VDC Power System

System Application Guide

Cable Assemblies with IEC 60309 530P7W Plug

Features

- ◆ Includes 5-wire AC input line cord. Factory connected at one end is a connector that plugs into a mating connector on the rear of the power shelf and on the other end with an IEC, 530P7W, 30 A / 32 A plug. See Figure 4.
- ◆ Available in various lengths.

Restrictions

Plug rated for 32 A.

Ordering Notes

- 1) Order two (2) as required for a 1PSS503321N2 shelf.
 - a) P/N 10283964 = 1.5 meters (4.92 feet) long
 - b) P/N 10283966 = 2.5 meters (8.20 feet) long
 - c) P/N 10283967 = 3.5 meters (11.48 feet) long
 - d) P/N 10283974 = 4.5 meters (14.8 feet) long
 - e) P/N 10283975 = 5.5 meters (18.0 feet) long
 - f) P/N 10284153 = 6.5 meters (21.3 feet) long

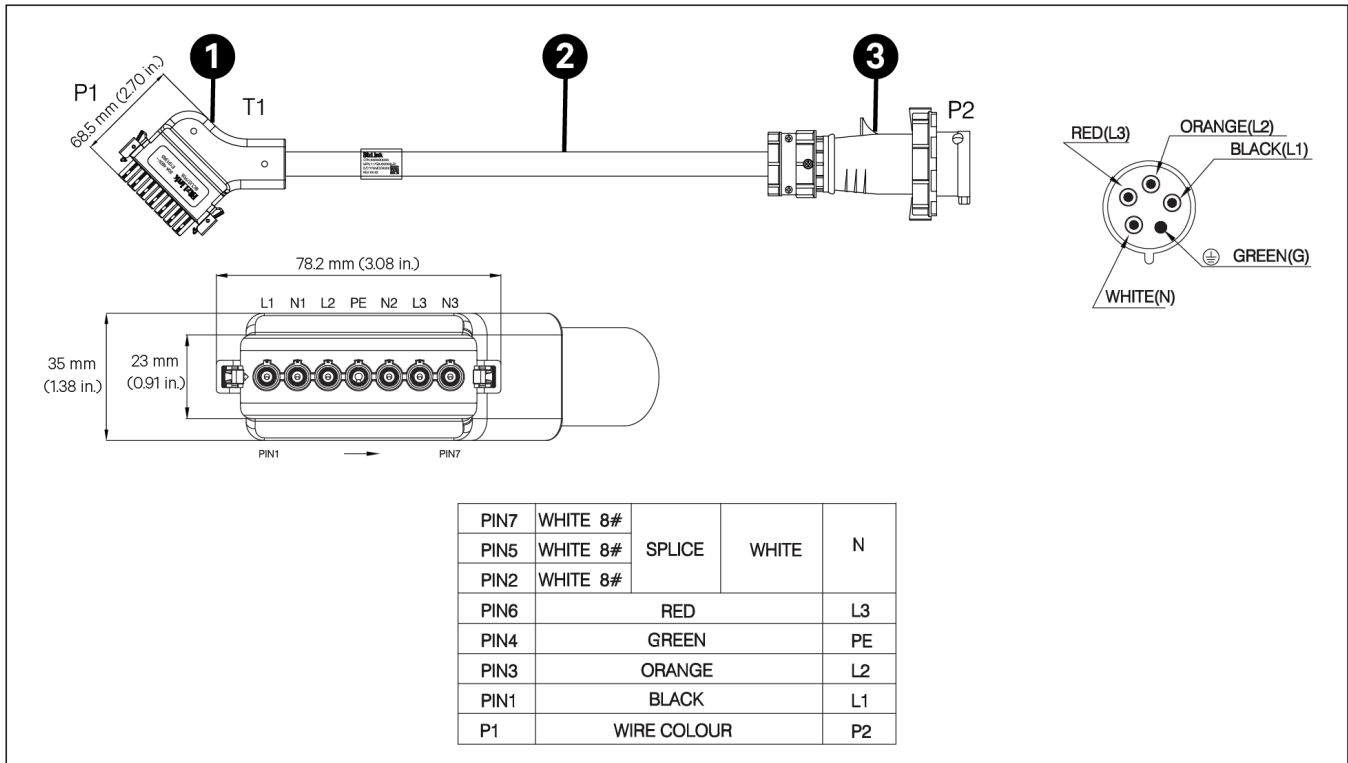

Item	Description
1	7 Pin Female Connector
2	TYPE SOOW 5C x 8 AWG Cable
3	IEC, 60309, 530P7W, 30 A / 32 A Plug

Figure 4

AC Input Cable Assembly IEC 60309 530P7W Plug

PowerDirect 50 VDC Power System

System Application Guide

Cable Assemblies with IEC 60309 460P9W Plug

Features

- ◆ Includes 4-wire AC input line cord. Factory connected at one end is a connector that plugs into a mating connector on the rear of the power shelf and on the other end with an IEC, 460P9W, 60 A plug. See Figure 5.
- ◆ Available in various lengths.

Restrictions

Plug rated for 60 A.

Ordering Notes

- 1) Order two (2) as required for a 1PSS503321N2 shelf.
 - a) P/N 10283935 = 1.5 meters (4.92 feet) long
 - b) P/N 10283937 = 2.5 meters (8.20 feet) long
 - c) P/N 10283938 = 3.5 meters (11.48 feet) long
 - d) P/N 10283952 = 4.5 meters (14.8 feet) long
 - e) P/N 10283953 = 5.5 meters (18.0 feet) long
 - f) P/N 10283954 = 6.5 meters (21.3 feet) long

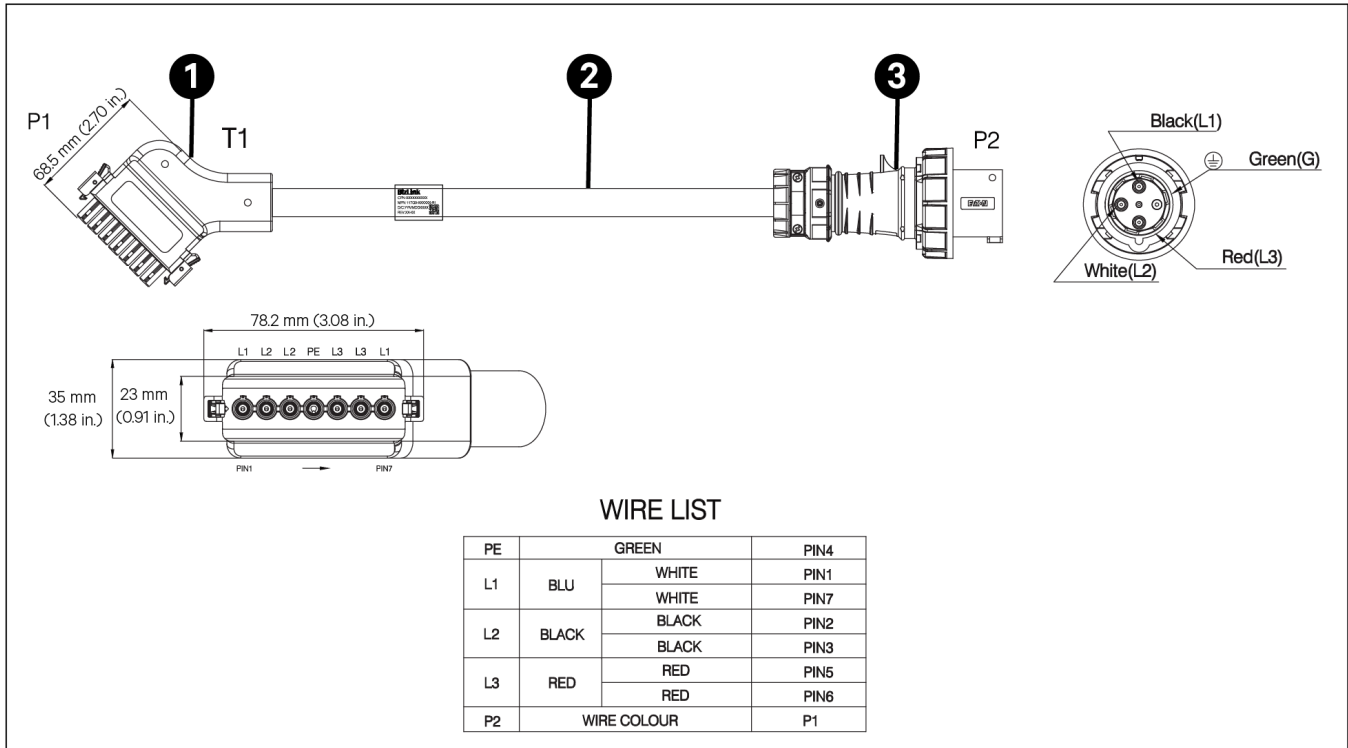

Item	Description
1	7 Pin Female Connector
2	TYPE SOOW 4C x 8 AWG Cable
3	IEC, 60309, 460P9W, 60 A Plug

Figure 5

AC Input Cable Assembly IEC 60309 460P9W Plug

PowerDirect 50 VDC Power System

System Application Guide

Cable Assemblies with NEMA L22-30P Plugs

Features

- ◆ Includes 5-wire AC input line cord. Factory connected at one end is a connector that plugs into a mating connector on the rear of the power shelf and on the other end with a NEMA L22-30P 30 A plug. See Figure 6.
- ◆ Available in various lengths.

Restrictions

Plug rated for 30 A.

Ordering Notes

- 1) Order two (2) as required for a 1PSS503321N2 shelf.
 - a) P/N 10284160 = 1.5 meters (4.92 feet) long
 - b) P/N 10284161 = 2.5 meters (8.20 feet) long
 - c) P/N 10284162 = 3.5 meters (11.48 feet) long
 - d) P/N 10284163 = 4.5 meters (14.8 feet) long
 - e) P/N 10284164 = 5.5 meters (18.0 feet) long
 - f) P/N 10284165 = 6.5 meters (21.3 feet) long

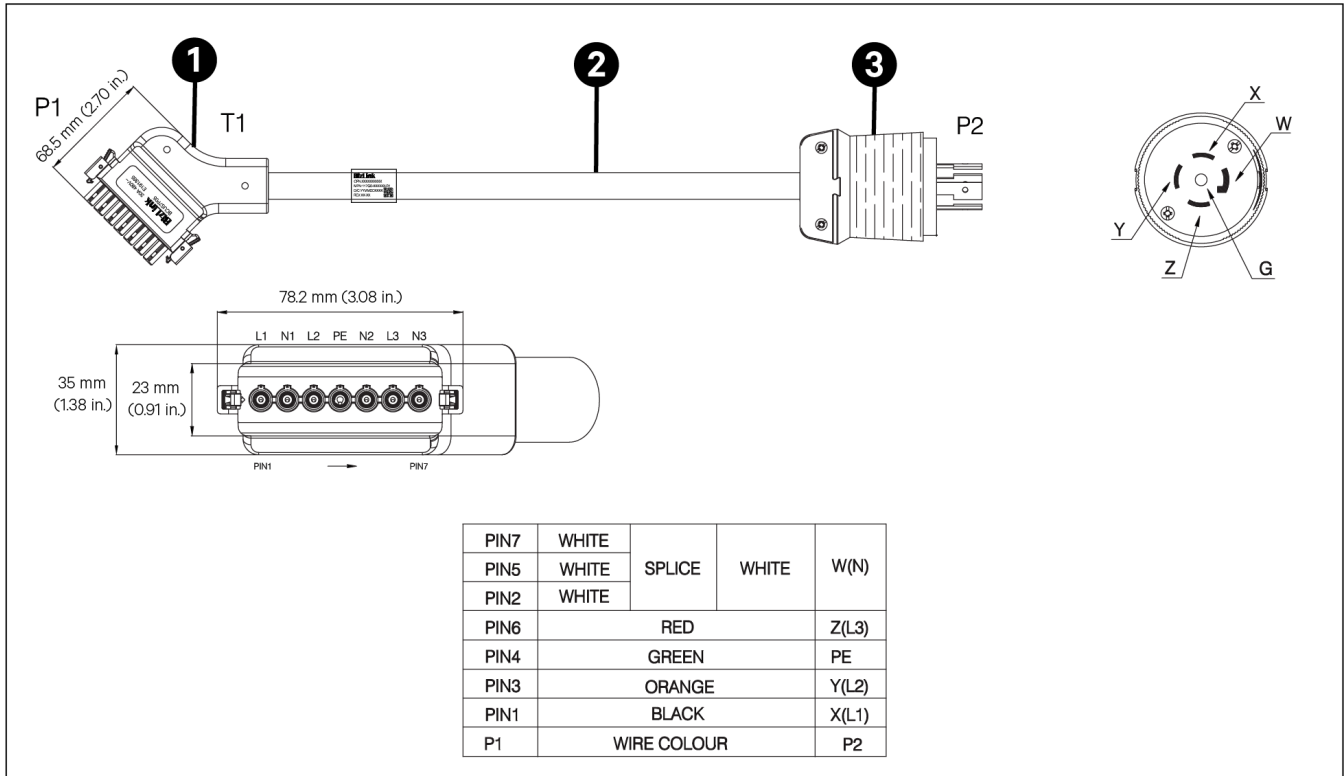

Item	Description
1	7 Pin Female Connector
2	TYPE W 2000 V Cable
3	NEMA L22-30P 30 A Plug

Figure 6

AC Input Cable Assembly NEMA L22-30P Plug

PowerDirect 50 VDC Power System

System Application Guide

Cable Assemblies with NEMA L26-30P Plugs

Features

- ◆ Includes 5-wire AC input line cord. Factory connected at one end is a connector that plugs into a mating connector on the rear of the power shelf and on the other end with a NEMA L26-30P 30 A plug. See Figure 7.
- ◆ Available in various lengths.

Restrictions

Plug rated for 30 A.

Ordering Notes

- 1) Order two (2) as required for a 1PSS503321N2 shelf.
 - a) P/N 10284166 = 1.5 meters (4.92 feet) long
 - b) P/N 10284167 = 2.5 meters (8.20 feet) long
 - c) P/N 10284168 = 3.5 meters (11.48 feet) long
 - d) P/N 10284169 = 4.5 meters (14.8 feet) long
 - e) P/N 10284170 = 5.5 meters (18.0 feet) long
 - f) P/N 10284171 = 6.5 meters (21.3 feet) long

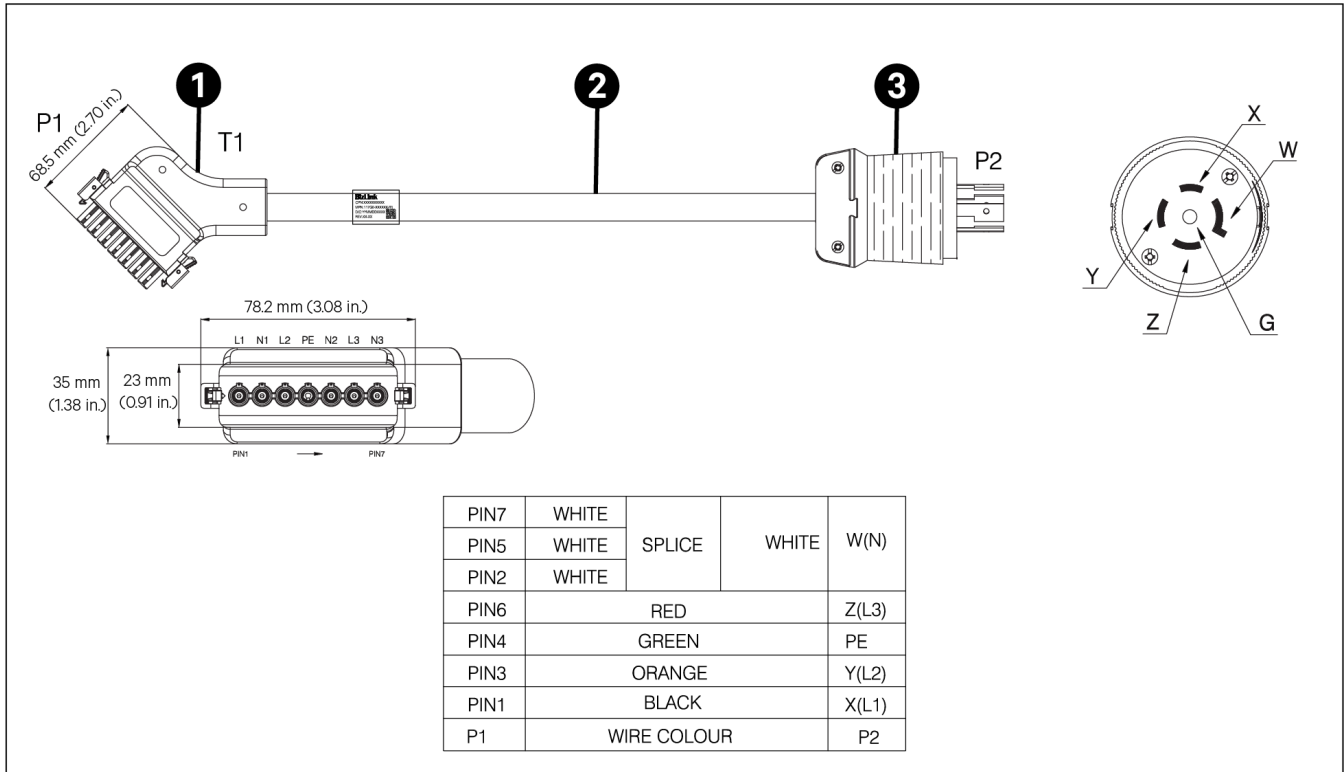

Item	Description
1	7 Pin Female Connector
2	TYPE W 2000 V Cable
3	NEMA L26-30P 30 A Plug

Figure 7
AC Input Cable Assembly NEMA L26-30P Plugs

Controller

P/N 1PMM1S0

Features

- ◆ The Power Monitoring Module (PMM) (Spec. No. 1PMM1S0).
- ◆ Factory programmed.
- ◆ Refer to the Controller Instructions (UM1PMM1S0) for more information.

Restrictions

Each power shelf requires a controller.

Ordering Notes

- 1) Order one P/N 1PMM1S0 for each power shelf.

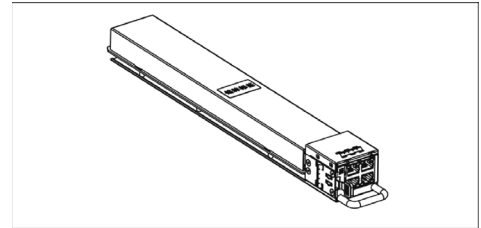

Power Supply Unit (PSU)

P/N 1R505500E4

Features

- ◆ The power supply unit (PSU), Model R50-5500E4 (Spec. No. 1R505500E4), 5500 watt / 50 VDC.
- ◆ Refer to the PSU Instructions (UM1R505500E4) for more information.

Restrictions

Each shelf holds up to a total six (6) PSUs.

Ordering Notes

- 1) Order by P/N 1R505500E4 as required.

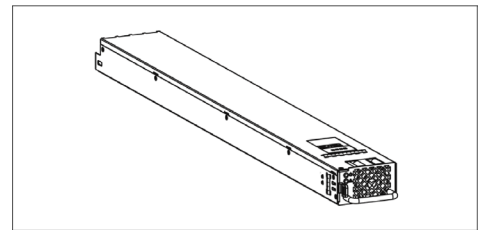

ACCESSORY DESCRIPTIONS

PSU Mounting Position Blank Cover Panel, P/N 10162462

Features

- ◆ Covers one (1) unused PSU mounting position.

Ordering Notes

- 1) Order by P/N 10162462 as required. Order a PSU mounting position blank cover panel for each empty PSU mounting position in the system.

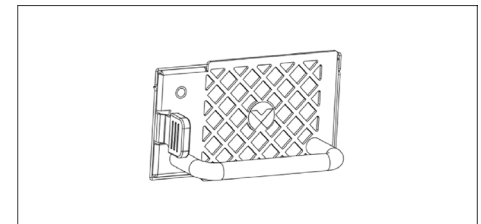

Mounting Rail Kit for OCP HPR Rack, P/N 10274006

Features

- ◆ Mounting rail kit to secure the power shelf into an OCP HPR (21") rack.

Ordering Notes

- 1) Order by P/N 10274006 as required, one (1) kit per shelf.

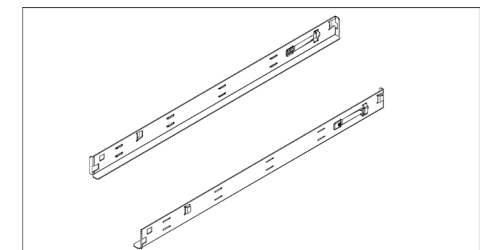

User Replaceable Components

Ordering Notes

- 1) Refer to Table 1 for user replaceable components.

Item	Part Number
Power Supply Unit (PSU)	1R505500E4
Controller	1PMM1S0
Short Network Cable	528520
Long network cable	10174051

Table 1
User Replaceable Components

RECOMMENDED WIRING SIZES, BRANCH CIRCUIT PROTECTION, CRIMP LUGS, AND WIRING ILLUSTRATIONS

Refer to the current edition of the American National Standards Institute (ANSI) approved National Fire Protection Association's (NFPA) National Electrical Code (NEC), applicable local codes, and your specific site requirements. For operation in countries where the NEC is not recognized, follow applicable codes.

Power Shelf Frame Grounding Requirements

A customer's frame grounding network lead is factory connected to the M5 frame ground screw located at the rear of each power shelf. See Figure 5. Recommended wire size is 8 AWG (6 mm²).

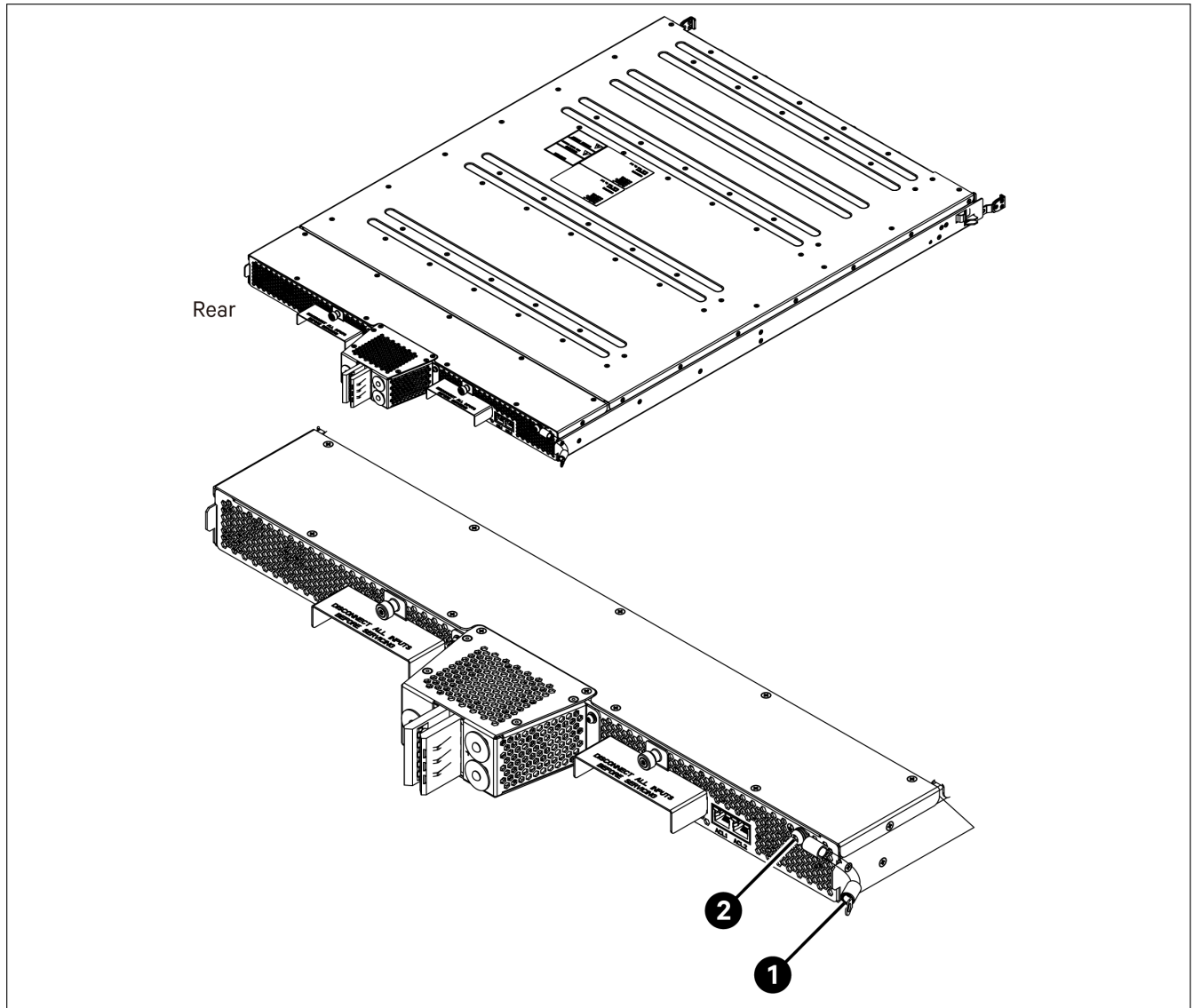

Item	Description
1	A customer's frame grounding network lead is factory connected to the M5 ground screw. The ground wire diameter is 8 AWG (6 mm ²).
2	 Shelf Frame Grounding Connection M5 Screw. Torque: 2 Nm (17.7 in-lbs.)

Figure 8
Power Shelf Frame Grounding

Power Shelf AC Input Connections

The power shelf provides connections for two (2) AC input feeds, each feed has three PSUs.

AC input is connected to the “Input 1” and “Input 2” connectors. Two (2) AC input cable options are available which provides an AC cord and mating connector. Size the overcurrent protective devices per the AC input cable plug rating.

AC Input Cable Assembly (NEMA AC Input)

See Figure 6 and Table 2.

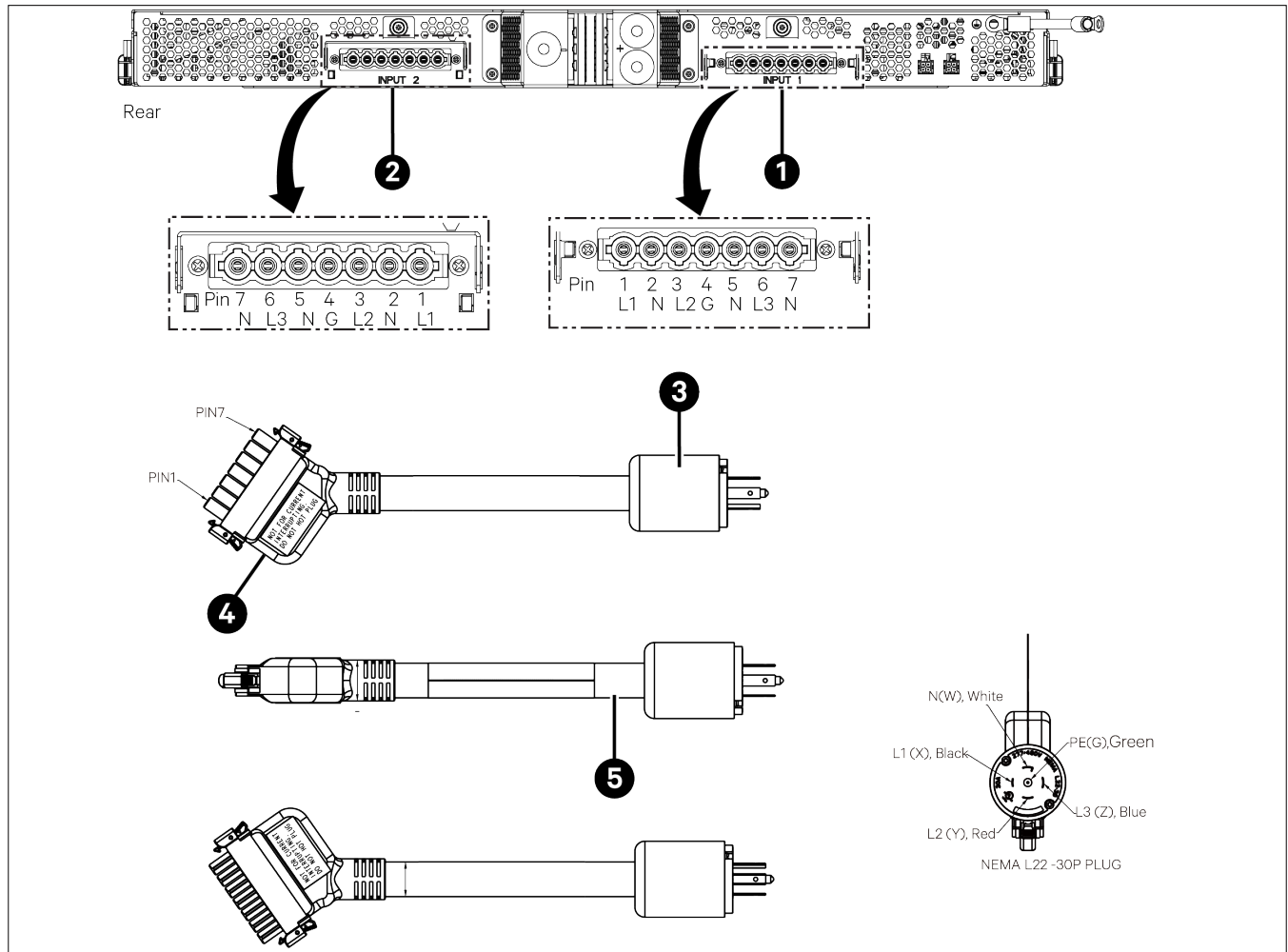

Item	Description	Item	Description
1	AC Input #1	4	7 Pin Female Connector
2	AC Input #2	5	TYPE W 5X 10 AWG Cable
3	NEMA L22-30P 30 A Plug	--	--

Figure 9
AC Input Cable Assembly with L22-30P plug

PowerDirect 50 VDC Power System System Application Guide

Refer to Table 2 for recommended AC input branch circuit protection.

Input Voltage	Nominal Input Current	Overcurrent Protection ⁽¹⁾
415 / 240 VAC	23.4 A	Size per AC Line Cord Plug Rating
480 / 277 VAC	20.2 A	Size per AC Line Cord Plug Rating

¹ The AC input branch circuit protective device should be of the time-delay or high inrush type.

Table 2
Recommended AC Input Branch Circuit Protection (Nominal 415 / 240 VAC 480 / 277 VAC, Three Phase, 50 Hz / 60 Hz)
AC Input Cable Assembly

PowerDirect 50 VDC Power System System Application Guide

AC Input Cable Assembly with 60309 Plug

See Figure 7 and Table 3.

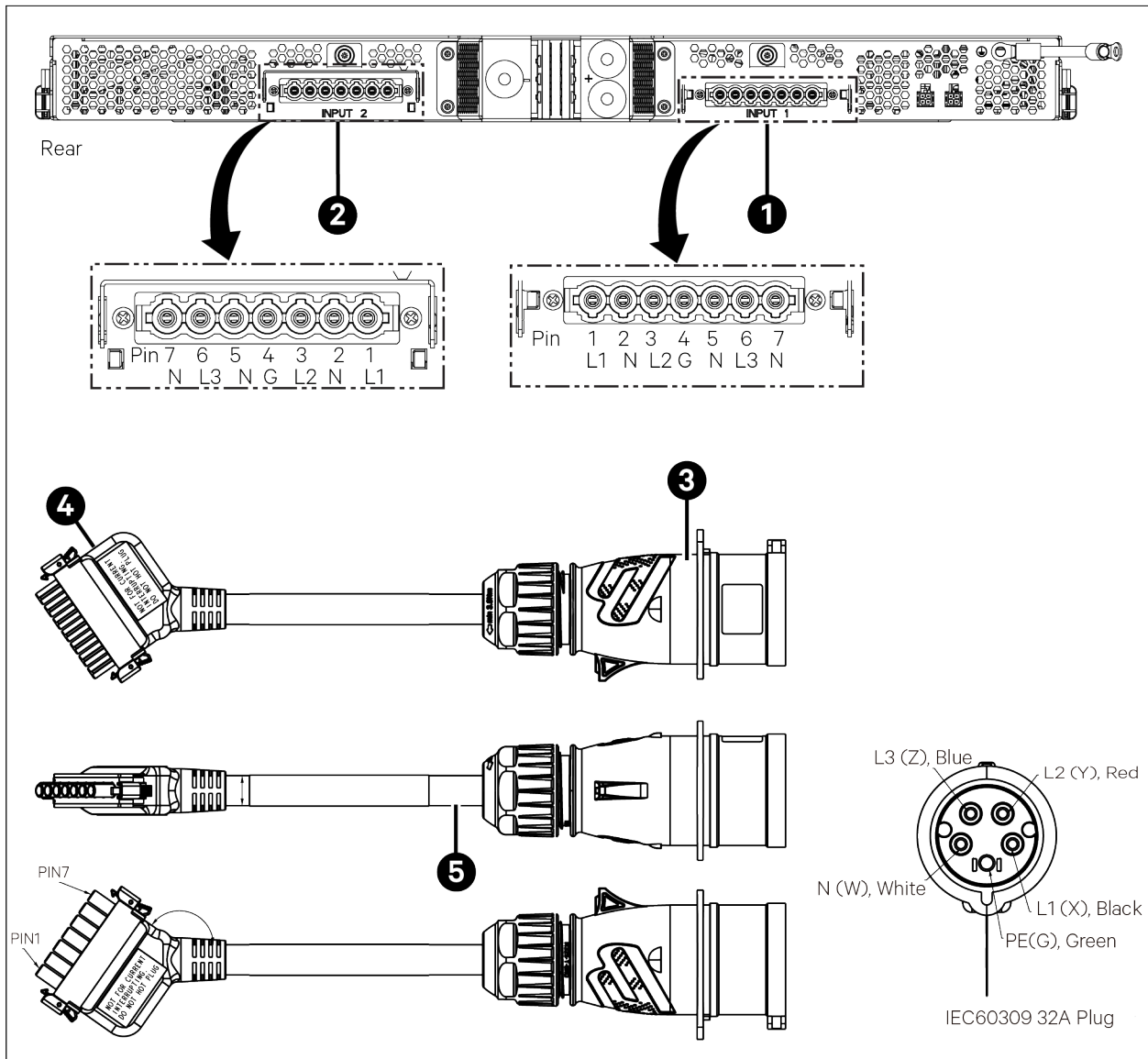

Item	Description	Item	Description
1	AC Input #1	4	7 Pin Female Connector
2	AC Input #2	5	TYPE W 5X 10 AWG Cable
3	IEC, 530P6, 32 A Plug	--	--

Figure 10
AC Input Cable Assembly

PowerDirect 50 VDC Power System System Application Guide

Refer to Table 3 for recommended AC input branch circuit protection.

Input Voltage	Nominal Input Current	Overcurrent Protection ⁽¹⁾
400 / 230 VAC	24.9 A	Size per AC Line Cord Plug Rating
415 / 240 VAC	23.8 A	Size per AC Line Cord Plug Rating

¹ The AC input branch circuit protective device should be of the time-delay or high inrush type.

Table 3
Recommended AC Input Branch Circuit Protection (Nominal 400 / 230 VAC or 415 / 240 VAC, Three Phase, 50 Hz / 60 Hz) AC
Input Cable Assembly

Power Shelf DC Output Connections

DC output is provided via a DC output connector located on the back of the power shelf as shown in Figure 8. This connector is compatible to mate with the vertical DC busbar set in an Open Compute Project version 3 HPR rack.

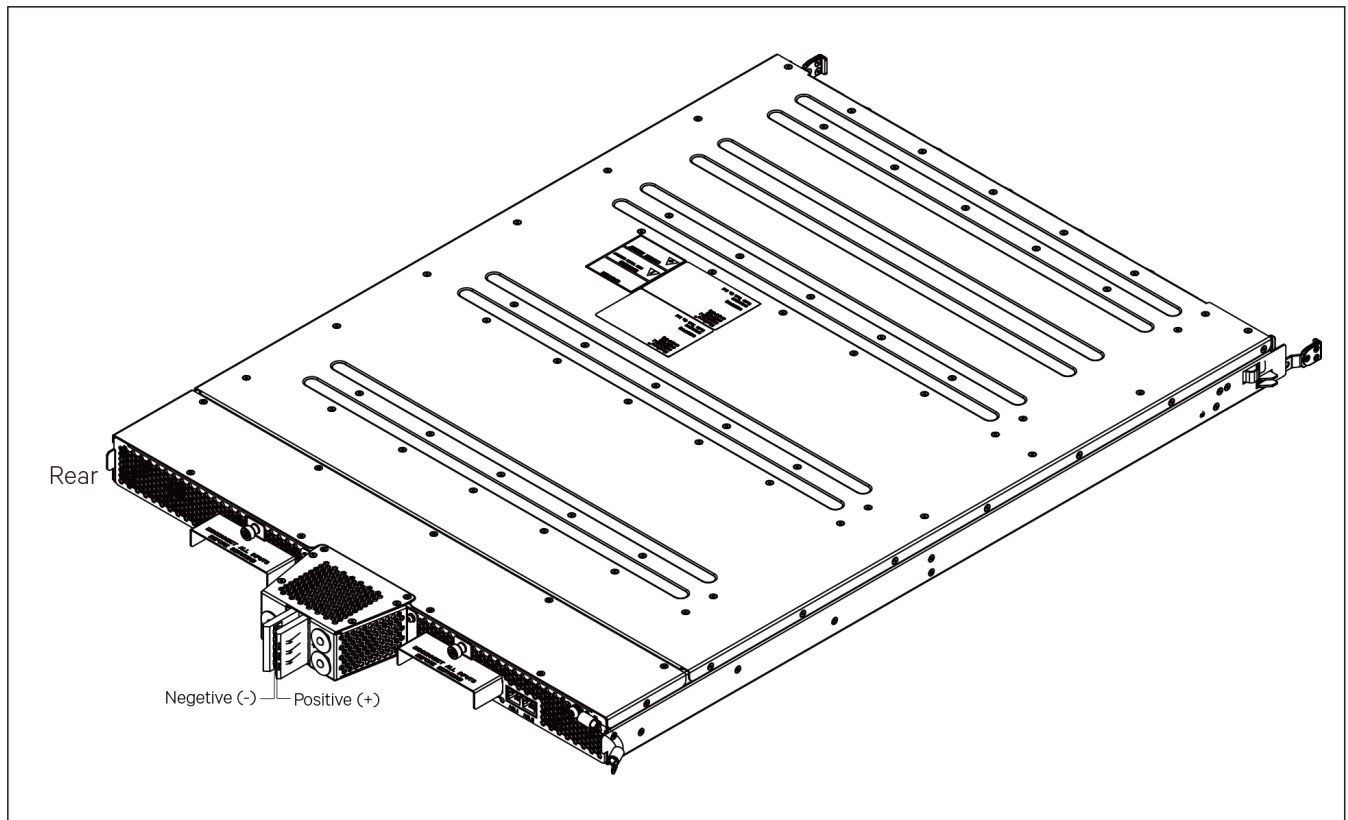

Figure 11
Power Shelf DC Output

Controller Front Panel RJ45 Connectors

General

In the front of the PMM, there is a single 4x RJ45 connector. This is a modular jack connector in a 2x2 configuration of RJ45s with two LEDs. Looking from the front, top left RJ45 is #1, top right is #2, bottom left is #3, bottom right is #4. RJ45 #1&2:

RJ45 Port #1 and Port #2 include electrical connections for Modbus communications, address pins, and alarm signals. The dual-port design allows for daisy-chain Modbus connections with multiple PSU shelves, BBU shelves, and RPU's on the same daisy chain.

RJ45 #3 and #4 include signals for internal rack control. Connections between different types of racks are not allowed. Pin 6 on #3 and #4 is used to monitor if the daisy chain cable is installed or missing.

Communication with rack monitor via Modbus. RJ45 #3&4: Intended for inter shelf control and multiple shelf parallel operation.

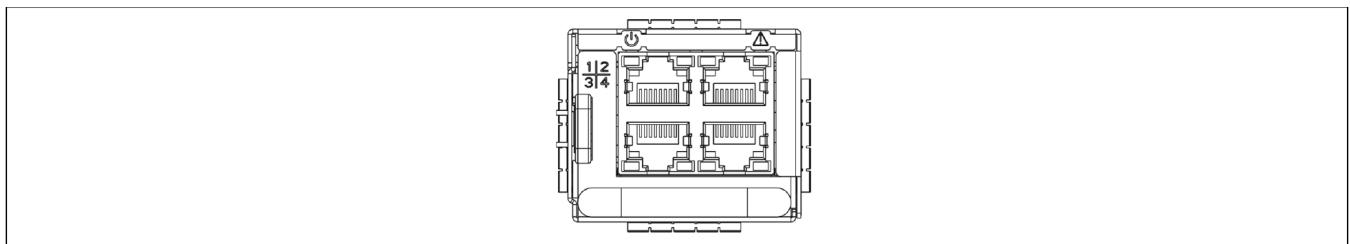

Figure 12
RJ45 Connectors

Note: There are two kinds of network cable (P/N 528520 and P/N 10174051); the default configuration is to use the short network cable (P/N 528520) for parallel operation. When the distance between two shelves in the rack exceeds 250 mm (9.84 inches), order long network cable (P/N 10174051).

RJ45 #1			RJ45 #2		
Pin	Wire Color	Function	Pin	Wire Color	Function
1	White/Orange	GND	1	White/Orange	GND
2	Orange	PLS	2	Orange	PLS
3	White/Green	CLS	3	White/Green	CLS
4	Blue	RS485A	4	Blue	RS485A
5	White/Blue	RS485B	5	White/Blue	RS485B
6	Green	RS485_Addr2	6	Green	RS485_Addr2
7	White/Brown	RS485_Addr1	7	White/Brown	RS485_Addr1
8	Brown	RS485_Addr0	8	Brown	RS485_Addr0
RJ45 #3			RJ45 #4		
Pin	Wire Color	Function	Pin	Wire Color	Function
1	White/Orange	ISHARE	1	White/Orange	ISHARE
2	Orange	GND	2	Orange	GND
3	White/Green	SYNC_START_L	3	White/Green	SYNC_START_L
4	Blue	CAN_H	4	Blue	CAN_H_OUT
5	White/Blue	CAN_L	5	White/Blue	CAN_L_OUT
6	Green	SYNC_STOP_L	6	Green	SYNC_STOP_L
7	White/Brown	SOH_L	7	White/Brown	SOH_L
8	Brown	Missing Daisy Chain Cable	8	Brown	GND

Table 4
RJ-45 Pin Configuration

SPECIFICATIONS

1. SYSTEM

1.1 System DC Output Ratings

See page 2.

1.2 System Input Ratings

See page 2.

1.3 System Environmental Ratings

1.3.1 Operating Ambient Temperature Range: -20 °C (-4 °F) to +45 °C (+113 °F) with full power performance. +45 °C (+113 °F) to +65 °C (+149 °F) with derating output.

1.3.2 Storage Ambient Temperature Range: -40 °C (-40 °F) to +70 °C (+158 °F).

1.3.3 Relative Humidity: This power system is capable of operating in an ambient relative humidity range of 10% to 90%, non-condensing.

1.3.4 Altitude: 3000 m (9843 ft) at full power (power limited for heights above 3000 m). Derate operating ambient temperature range by 1 °C per 300 m above 3000 m.

1.3.5 PE Wire Current: 105 mA or less.

1.3.6 High Voltage Category: II.

1.3.7 Pollution Degree: II.

Note: The Power Supply Unit module is recommended to be used in an environment with Pollution of Degree 2 or less. Pollution Degree 2 applies where there is only non-conductive pollution that might temporarily become conductive due to occasional condensation (such as the office environment).

1.3.8 Ventilation Requirements: The PSUs are fan cooled and utilize front to back forced ventilation. The power system must be mounted so ventilating openings are not blocked and temperature of the air entering the power system does not exceed the operating ambient temperature range stated above.

1.3.9 Single PSU Audible Noise: At 25 °C ≤85dB(A) with fan in high speed.

1.3.10 Surge Protection: Compliance with EN61000-4-5 (1kV Line to Line, 2kV Line to Earth).

Note: This level of protection is a widely used standard for data-center application. As with all such equipment, it is the end user's responsibility to provide an adequately sized Surge Suppression Device at the commercial power service entrance of the building that reduces all incoming surges to levels below the classes/categories stated for the equipment.

1.3.11 EMI: Conform to the requirements of European Norm, EN55032, Class A for Radiated and Conducted emissions limits.

1.3.12 Mounting: This product is intended only for installation in a restricted access location on or above a non-combustible surface.

- This product must be located in a controlled environment with access to crafts persons only.
- This product is intended for installation in data centers or network telecommunication facilities (CO, vault, hut, or other environmentally controlled electronic equipment enclosure).
- This product is intended to be installed in a data center facility and be connected to a MESH-bonding network (MESH-BN) or to the common bonding network in a network telecommunication facility (CO, vault, hut, or other environmentally controlled electronic equipment enclosure).
- This system is suitable for installation as part of the Common Bonding Network (CBN) or a data center building MESH-bonding network (MESH-BN).
- PSU and power shelf ventilating openings must not be blocked and temperature of air entering these must not exceed the rated operating ambient temperature range.
- DC shelves may be stacked together, with no space between them.

1.4 System Compliance Information

1.4.1 Safety Compliance:

(A) This unit meets the requirements of UL62368-1, Standard for Information Technology Equipment, and is UL Recognized as a power supply for use in Telephone, Electronic Data Processing or Information Processing Equipment.

(B) CAN/CSA C22.2 No. 62368-1, IEC 62368-1

1.5 Local Controls and Indicators

1.5.1 Controller: Refer to the Controller Instructions (UM1PMM1S0).

1.5.2 PSU: Refer to the PSU Instructions (UM1R505500E4).

MECHANICAL SPECIFICATIONS

Overall Dimensions – SAG 1PSS503321N2

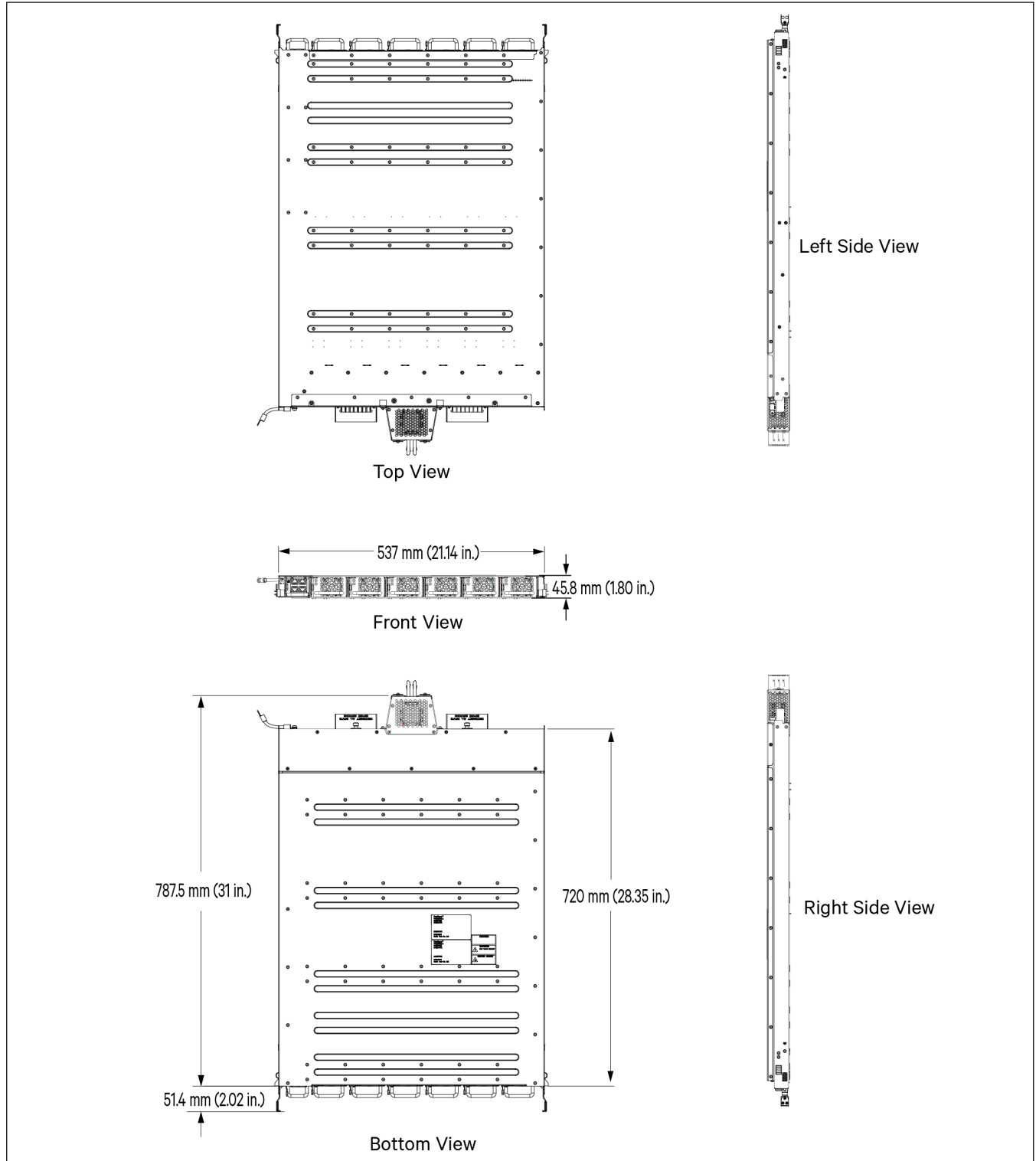

Weights

Part Number	Net Weight, each
1PSS503321N2 Power Shelf	11.1 kg (24.5 lbs)
1R505500E4 PSU	3.2 kg (7.05 lbs)
1PMM1S0 Controller	0.6 kg (1.3 lbs)
10143072	1.7 kg (3.75 lbs)
10143073	3.0 kg (6.61 lbs)
10143074	3.7 kg (8.16 lbs)
10143069	2.2 kg (4.85 lbs)
10143070	2.9 kg (6.39 lbs)
10143071	3.6 kg (7.94 lbs)

RELATED DOCUMENTATION

System Installation and User Instructions:	UM1PSS5033
Controller Instructions:	UM1PMM1S0
PSU Instructions:	UM1R505500E4

Vertiv.com | Vertiv Headquarters, 505 N Cleveland Ave, Westerville, OH 43082, USA

© 2026 Vertiv Group Corp. All rights reserved. Vertiv™ and the Vertiv logo are trademarks or registered trademarks of Vertiv Group Corp. All other names and logos referred to are trade names, trademarks or registered trademarks of their respective owners. While every precaution has been taken to ensure accuracy and completeness here, Vertiv Group Corp. assumes no responsibility, and disclaims all liability, for damages resulting from use of this information or for any errors or omissions.

