



# Liebert® Mini-Mate2

## System Design Catalog

8-ton (28-kW) Capacity, Air, Water, Glycol, GLYCOOL, Chilled Water;  
50 and 60 Hz

The information contained in this document is subject to change without notice and may not be suitable for all applications. While every precaution has been taken to ensure the accuracy and completeness of this document, Vertiv assumes no responsibility and disclaims all liability for damages result from use of this information or for any errors or omissions.

Refer to local regulations and building codes relating to the application, installation, and operation of this product. The consulting engineer, installer, and/or end user is responsible for compliance with all applicable laws and regulations relation to the application, installation, and operation of this product.

The products covered by this instruction manual are manufactured and/or sold by Vertiv. This document is the property of Vertiv and contains confidential and proprietary information owned by Vertiv. Any copying, use, or disclosure of it without the written permission of Vertiv is strictly prohibited.

Names of companies and products are trademarks or registered trademarks of the respective companies. Any questions regarding usage of trademark names should be directed to the original manufacturer.

### **Technical Support Site**

If you encounter any installation or operational issues with your product, check the pertinent section of this manual to see if the issue can be resolved by following outlined procedures.

Visit <https://www.vertiv.com/en-us/support/> for additional assistance.

## TABLE OF CONTENTS

<b>1 Introduction</b> .....	<b>1</b>
1.1 Designed to Match Computer and Electronic Equipment Needs from Installation to Operation .....	1
1.2 Agency Listed .....	2
<b>2 Features and Options</b> .....	<b>3</b>
2.1 Standard Features .....	3
2.1.1 Evaporator Section—Split Systems .....	3
2.1.2 Condensing Unit Section—Split Systems .....	3
2.1.3 Chilled Water Units .....	3
2.1.4 System Controls .....	4
2.1.5 Three Cooling Levels .....	4
2.1.6 Sensors and Switches .....	5
2.2 Optional Factory Installed Features .....	6
2.2.1 Evaporator/Chilled Water Unit Options .....	6
2.2.2 Free Cooling for Evaporator Units .....	7
2.2.3 Optional Configurations—Prop Fan Condensing Units .....	7
2.2.4 Optional Configurations—Water/Glycol Condensing Units .....	8
2.2.5 Optional Configurations—Chilled Water Units .....	8
2.3 Ship-Loose Accessories—Field-Installed .....	8
2.3.1 Remote Monitoring, Autochangeover, and Leak Detection Equipment .....	8
<b>3 Nomenclature</b> .....	<b>11</b>
3.1 System Configurations .....	11
3.2 Nomenclature for Evaporator and Chilled Water Units .....	13
3.3 Nomenclature for Split-system Condensing units .....	15
3.3.1 Indoor Condensing Units for Air Cooled Split Systems .....	15
3.3.2 Outdoor Prop Fan Condensing Units for Air Cooled Split Systems .....	16
3.3.3 Water/Glycol Cooled Condensing Units .....	17
<b>4 System Data</b> .....	<b>19</b>
4.1 Air Cooled Systems—Capacity and Performance Data .....	19
4.2 Water/Glycol Cooled Systems—Capacity and Performance Data .....	23
4.3 Chilled Water Systems—Capacity and Performance Data .....	28
4.4 Planning Dimensions .....	30
<b>5 Electrical Data</b> .....	<b>31</b>
5.1 Evaporators and Chilled Water Units Electrical Data .....	31
5.2 Indoor Condensing Units Electrical Data .....	34
5.3 Outdoor Condensing Units Electrical Data .....	34
5.4 Electrical Data for Air-cooled Systems Using a Single-point Power Kit .....	35
5.5 Electrical Data for Water/Glycol Cooled Systems Using a Single-point Power Kit .....	37
5.6 Electrical Field Connections .....	39

<b>6 Piping</b> .....	<b>41</b>
6.1 Refrigerant Piping Data .....	41
6.1.1 Refrigerant Charge Requirements .....	41
6.1.2 Refrigerant Line Sizes and Equivalent Lengths .....	42
6.1.3 Piping when Condensing Unit is Above or Below Evaporator .....	43
6.2 Glycol Loop Piping .....	44
<b>Appendices</b> .....	<b>45</b>
Appendix A: Technical Support and Contacts .....	45
Appendix B: Guide Specifications .....	47
Appendix C: Submittal Drawings .....	49

# 1 Introduction

## 1.1 Designed to Match Computer and Electronic Equipment Needs from Installation to Operation

Installed above the ceiling, Vertiv™ Liebert® Mini-Mate2 Thermal Management systems control the cooling, humidity and air distribution required by sensitive electronic equipment. A range of sizes and configurations is available to meet varying site needs.

The Liebert® Mini-Mate2 is also easy to use. Advanced microprocessor technology allows easy, precise control, and menu-driven monitoring keeps you informed of system operation through the LCD readout. These features, combined with Vertiv quality construction and reliable components, guarantee satisfaction from installation through operation.

### Liebert Thermal Management

Liebert Thermal Management systems control the temperature and humidity required for computers and other sensitive electronic equipment. The Liebert® Mini-Mate2 provides complete control on an around-the-clock basis and the high sensible-heat ratio required by sensitive electronic equipment.

### Easy Installation

The Liebert® Mini-Mate2 is a split-system evaporator combined with an air-, water- or glycol-cooled condensing unit or is a self-contained, chilled-water unit. Each split system has thermostat-type wiring to controls and condensing unit.

### Easy to Service

Low-maintenance components are easily accessed through removable front panels. Spare parts are always in Vertiv inventory and available on short notice.

### Advanced Control Technology

A menu-driven microprocessor control system provides precise temperature and humidity control and accurate alarm setpoints. Using touch-sensitive buttons, the wall-mounted monitor/control panel allows you to select and display temperature and other monitored parameters.

### High Efficiency

High sensible heat ratio, scroll compressor, and precise microprocessor control allow the system to operate efficiently.

### Space-saving Design

All indoor components are installed above the ceiling, so no floor space is required.

### Reliable

The Liebert® Mini-Mate2 family installed base is a testimony to the system reliability. Components include a rugged scroll compressor, high-efficiency copper tube, aluminum-fin evaporator coil and a double inlet, direct-drive fan.

## 1.2 Agency Listed

Standard 60-Hz units are CSA Certified to the harmonized U.S. and Canadian product safety standard CSA C22.2 No 236/UL 1995 for “Heating and Cooling Equipment” and are marked with the CSA c-us logo.



## 2 Features and Options

### 2.1 Standard Features

#### 2.1.1 Evaporator Section—Split Systems

The Vertiv™ Liebert® Mini-Mate2 systems consist of an evaporator section matched with an outdoor air-cooled condensing unit, indoor air-cooled condensing unit or indoor water/glycol-cooled condensing unit. The system is also available as a self-contained chilled water unit. Unit insulation meets ASHRAE 62.1 requirements for Mold Growth, Humidity & Erosion, tested per UL 181 and ASTM 1338 standards.

The evaporator unit (for ducting only) includes a dual-circuited evaporator coil, filter-driers, expansion valves, factory-mounted disconnect switch, adjustable, belt-drive blower assembly, and microprocessor control with wall-mounted display panel. The unit is provided with supply- and return-air openings for field-supplied ducting. Suction and liquid lines are spun closed, and filled with an inert gas holding charge.

#### 2.1.2 Condensing Unit Section—Split Systems

##### Outdoor Air Cooled Prop Fan Condensing Units

The outdoor prop fan condensing unit includes 3 and 5 ton scroll compressors, two condenser coils, propeller fan, liquid line solenoid valve, high-pressure switches, Vertiv™ Liebert® Lee-Temp head pressure control, built-in receivers, and hot gas bypass. The condensing unit is designed for R-407C refrigerant and operates in outdoor locations at ambient temperatures ranging from -30°F to 95°F (-34°C to 35°C). Suction and liquid lines are spun closed, and filled with an inert gas holding charge.

##### Indoor Air Cooled Condensing Units

Indoor, air cooled, centrifugal fan condensing units include 3 and 5 ton scroll compressors, dual circuited condenser coil, factory mounted disconnect switch, belt-driven centrifugal blower assembly, high pressure switch, Liebert® Lee-Temp head pressure control system, hot-gas bypass and liquid line solenoid valve. Unit must be mounted indoors. Condensing unit is designed for R-407C refrigerant and will operate with outdoor air temperatures ranging from -30°F to 95°F (-34°C to 35°C). Suction and liquid lines are spun closed, and filled with an inert gas holding charge.

##### Indoor Water/Glycol Cooled Condensing Units

Indoor Water/Glycol Condensing Units include 3 and 5 ton scroll compressors, factory mounted disconnect, coaxial condensers, hot gas bypass, high head-pressure switches, and two-way water/glycol-regulating valves designed for 150 psi (1034.3 kPa). Condensing unit is designed for R-407C refrigerant and can be used on a water or glycol cooling loop. Suction and liquid lines are spun closed, and filled with an inert gas holding charge.

#### 2.1.3 Chilled Water Units

Chilled water Units are designed for ceiling installation. The cabinet and chassis are constructed of heavy gauge, galvanized steel. The unit can be serviced using only one side increasing its versatility in mounting locations. Mounting brackets are factory attached to the cabinet. Internal cabinet insulation meets ASHRAE 62.1 requirements for Mold Growth, Humidity and Erosion, tested per UL 181 and ASTM 1338 standards. The unit includes supply and return air openings for field supplied ducting.

Chilled water models are self-contained and include a chilled water coil, adjustable belt-driven blower assembly, factory mounted disconnect switch and 2-way proportional modulating valve. Design pressure is 400 psi (2757 kPa), 86 psi (593 kPa) close-off differential.

## 2.1.4 System Controls

System controls include a microprocessor control board mounted in the evaporator/chilled water unit and a wall-mounted interface with a two-line, 16-character liquid crystal display. A seven-key, membrane keypad for setpoint/program control, unit On/Off, and alarm silence is below the LCD screen. It provides temperature setpoint and sensitivity adjustment, humidity setpoint and sensitivity adjustment, digital display of temperature, humidity, setpoints, sensitivities, and alarm conditions.

The wall-box is field-wired to the microprocessor control using standard four-conductor, shielded thermostat wire (field-supplied). The temperature and humidity sensors are in the wall box, which can be installed up to 300 ft (91.4 m) from the evaporator unit when using a remote temperature/humidity sensor in the conditioned space. The unit-mounted control board also includes common-alarm terminals and shut-down terminals. The unit automatically restarts after a power outage.

Figure 2.1 Wall Box



## 2.1.5 Three Cooling Levels

A unique compressor staging system utilizes independent 3 ton and 5 ton circuits to provide better control of room conditions. The unit microprocessor continuously monitors recent cooling operation and selects the most economical cooling level to satisfy demand.

Figure 2.2 Improved Load Tracking

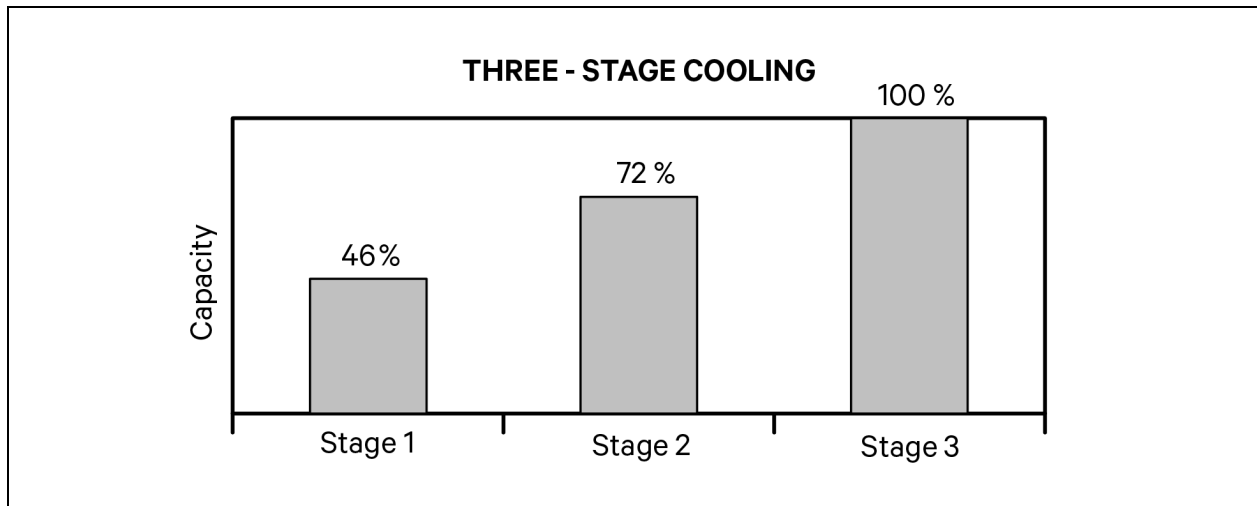

### Other Standard Control Features

- Adjustable auto restart
- 5 day/2 day setback
- Password protection
- Alarm enable/disable
- Self-diagnostics
- Calibrate sensors
- Predictive humidity control
- Common alarm output
- Remote shut-down terminals

### 2.1.6 Sensors and Switches

**High-Temperature Sensor** senses the return air temperature and shuts down the unit if the temperature reaches 125°F (52°C). This device is not meant to replace any fire-detection system that may be required by local or national codes.

**Filter Clog** senses pressure drop across the filters and activates visual and audible alarms at the wall-box display. The wall-box display annunciates the alarm and flashes a notification upon reaching a customer setpoint.

**Non-Fused Disconnect Switch** allows unit to be turned off for maintenance and is factory-installed on evaporators, chilled-water units, and indoor condensing units.

## 2.2 Optional Factory Installed Features

### 2.2.1 Evaporator/Chilled Water Unit Options

#### Reheat

**Electric Reheat** includes 2-stage, 304/304 stainless-steel, finned, tubular reheat element, with high-limit safety switch.

**SCR Electric Reheat** provides tight temperature control by rapidly pulsing the 304/304 stainless steel reheat elements in small increments. A solid state relay is factory-installed and wired to the microprocessor control. The compressor is locked on, with the reheat modulated to track the load. (The SCR Electric Reheat is not available on chilled-water, free-cooling, GLYCOOL, or 575-V units)

**Hot Water Reheat** includes hot-water coil, 2-way solenoid valve, and Y-strainer.

**NOTE: Hot-water reheat is available only on Chilled Water units, but not with other reheat options.**

#### Humidifier

The **Canister Humidifier** includes a steam-generating type humidifier with automatic flushing circuit, inlet strainer, drain, 1-in. (25.4-mm) air gap on fill line and solenoid valves. Humidifier problem alarm annunciates at the wall-mounted display panel.

**Remote Humidifier Contact** allows the unit's humidity controller to control a humidifier outside the unit. Power to operate the remote humidifier does not come from the Vertiv™ Liebert® Mini-Mate2. Available on units with or without internal humidifier.

#### Sensors

**Smoke Sensor** checks return air, shuts down the unit upon sensing smoke, and activates visual and audible alarms at the wall-box display. This smoke sensor is not intended to function as or replace any smoke sensor system that may be required by local or national codes.

#### Motors

**3-hp Blower Motor** is available for high static-pressure applications (0.9 to 1.9 in. [23 to 48 mm] w.g.). Standard 2-hp motor allows for ESP of 0.5 in. (13 mm). Free-cooling or hot-water-reheat coils reduce the available ESP by 0.3 in. (8 mm). Maximum return-air static pressure should not exceed 0.3 in. (8 mm) for drain to work properly.

#### Vertiv™ Liebert® IS-UNITY-DP BMS Monitoring Solution

The Liebert® IS-UNITY-DP card is a factory-installed option, providing full building-management system (BMS) access via BACnet/Modbus IP and BACnet/Modbus 485. Card provides access and supports SNMP v1/v2c/v3 & Vertiv™ Liebert® Nform. The card is factory-installed in a unit-mounted external enclosure and is factory-wired for communication to and powered from the Liebert® Mini-Mate2 unit. Field wiring to other systems required to access features.

## 2.2.2 Free Cooling for Evaporator Units

**NOTE:** The free cooling option is no longer available.

The GLYCOOL free cooling option includes separate cooling coil, three-way valve, fluid-temperature sensor, and separate supply and return piping. System includes an adjustable, timed flush cycle. Coil is active anytime there is a call for cooling and fluid temperature is 8°F (4.4°C) below room air temperature. The coil can provide the majority of the cooling with DX compressor coil cycled on as needed to complete the cooling requirements.

Air-cooled condensing units can be matched with evaporators using free-cooling coils with chilled-water sources to serve as back-up cooling. When matched with a water/glycol condensing unit, a three-way, water-regulating valve is recommended for the condensing unit to free-cooling sources, such as external chilled water or glycol from a drycooler loop. The coil is designed for closed-loop applications using properly-treated and circulated fluid. Not available with SCR reheat options.

**Free Cooling Arrangement** below, shows how a second cooling coil takes advantage of colder outdoor temperatures and bypasses compressor operation when using a drycooler loop. When the glycol temperature drops below the set threshold, cooling switches from compressor to free-cooling operation.

**NOTE:** If free cooling is applied to an open water tower, an optional cupro-nickel (CuNi) coil is required to prevent premature corrosion, or a heat exchanger must separate the tower water from the free-cooling loop. The cupro-nickel coil requires an extended lead time.

**Figure 2.3 Free Cooling Arrangement**

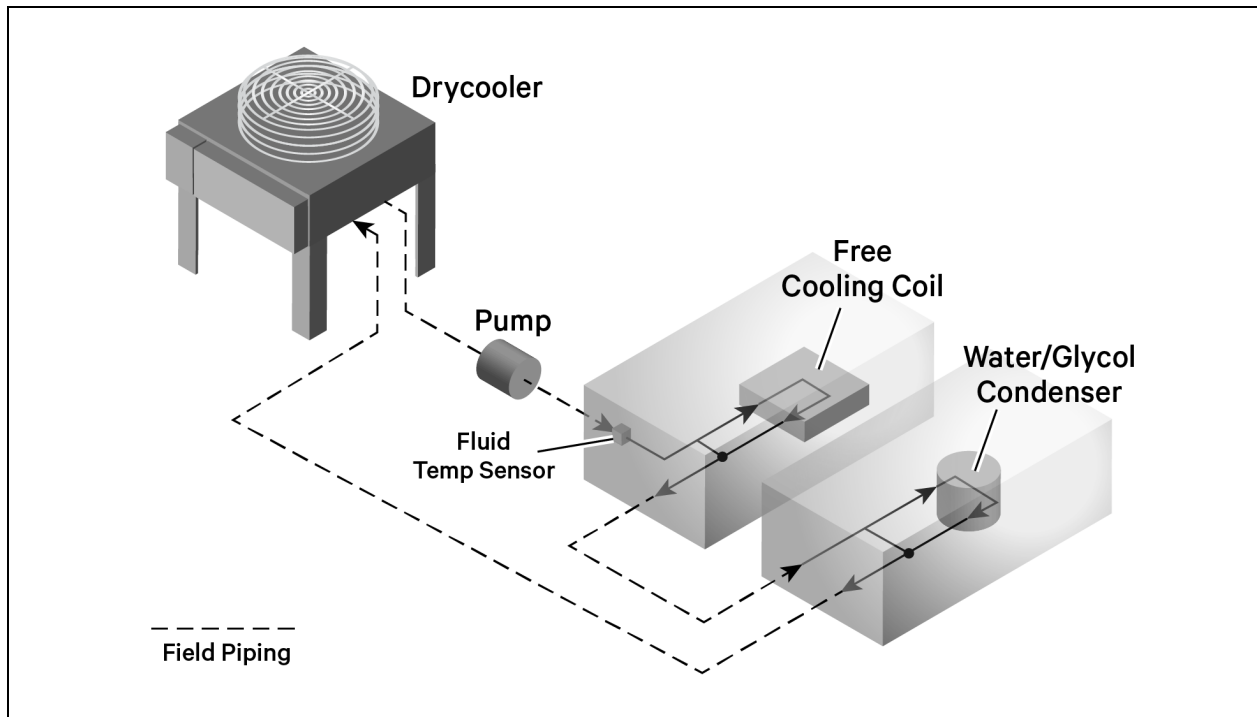

## 2.2.3 Optional Configurations—Prop Fan Condensing Units

**Outdoor Prop Fan Condensing Units** are available in the following optional configurations:

- Condenser coils can be epoxy-coated with UV topcoat at the factory for extended coil life in corrosive environments, such as coastal areas.

## 2.2.4 Optional Configurations—Water/Glycol Condensing Units

Water/Glycol Condensing Units are available with the following piping options:

- Two-way water-regulating valve with 350 psi (2413 kPa) design pressure.
- Three-way water-regulating valve with 150 psi (1034 kPa) design pressure.
- Three-way water-regulating valve with 350 psi (2413 kPa) design pressure.

## 2.2.5 Optional Configurations—Chilled Water Units

Chilled-water Units are also available with the following valve option:

- Three-way, modulating, chilled water valve, rated for 400 psi (2758 kPa) operating pressure. Valve is non-spring return.

## 2.3 Ship-Loose Accessories—Field-Installed

**Filter-box kit (for ducted applications)** includes return-airfilter box with duct-flange connection, two MERV 8 (ASHRAE 52.2-2007) filter (20-in. x 25-in. x 4-in. [508-mm x 635-mm x 102-mm]), and a duct flange for the supply-air opening of the unit.

The **Condensate Pump** is field-mounted outside the cabinet, wired to the unit power block, and equipped with a discharge check valve. A secondary float can be field-wired to shut-down the unit upon high-condensate level.

**Condensate Pump Mounting Bracket** mounts condensate pump on the end of the unit for easy alignment and installation of the condensate pump.

A **Remote Temperature and Humidity Sensor** package includes sensors in an attractive case with 30 ft (9 m) of cable. Can be wall- or duct-mounted. Remote sensors must be used when the wall box is not located in the space to be conditioned.

**NOTE: Installing the remote sensors disables the sensors included in the wall box.**

**Single-point Power Kit** contains the necessary electrical components to interconnect the high-voltage sections of a close-coupled evaporator and an indoor condensing unit.

### 2.3.1 Remote Monitoring, Autochangeover, and Leak Detection Equipment

The Vertiv™ Liebert® **IS-UNITY-DP BMS Monitoring Solution** provides full building-management system (BMS) access via BACnet/Modbus IP and BACnet/Modbus 485. Card provides access and supports SNMP v1/v2c/v3 & Vertiv™ Liebert® Nform. The unit-mount kit for field-installation includes the Liebert® IS-UNITY-DP card, power/communication interface card, enclosure, all required power and communication wires to the Vertiv™ Liebert® Mini-Mate2 unit, and full instructions. Field supplied wiring to other systems required to access features. The wall-mount kit for field installation includes the IS-UNITY-DP card, power/communication interface card, painted enclosure, 120-V wall-outlet transformer with 6-ft (2-m) low-voltage power wire, and full instructions. Field-supplied wiring for communication to Liebert® Mini-Mate2 and to other systems is required to access features.

The Vertiv™ Liebert® **RCM4** is a four-point, normally-open, dry-contact monitoring panel. One Form-C, dry-contact common-alarm-relay output (rated at 24 VAC, 3 Amp) is provided. Four red LEDs illuminate on the respective alarm and the alarm buzzer is silenced by a front-panel switch. The RCM4 requires a 24-VAC or 24-VDC power source. Power supply is not included.

The Vertiv™ Liebert® **Liqui-tect 410 Point Leak-Detection Sensor** detects the presence of conductive liquid using a pair of corrosion-resistant, gold-plated probes mounted in a painted, height-adjustable enclosure. Dual, Form-C, dry-contact common-alarm relays (rated at 24 VAC, 3 A) signal a leak detected as well as loss of power and cable fault. The Liebert® Liqui-tect 410 requires an external 24-VAC or 24-VDC power source.

**Vertiv™ Liebert® Liqui-tect 460 Zone Leak-Detection Kits** include one LT460 sensor, a specified length of LT500-xxY cable (maximum length is 100 ft [30.5 m]) and a corresponding number of hold-down clips. The Liebert® LT460 requires an external 24-VAC, 0.12-A power source such as EXT-XFMR or XFMR24.

This page intentionally left blank

### 3 Nomenclature

This section describes the model-number configuration for Vertiv™ Liebert® Mini-Mate2 units and components.

#### 3.1 System Configurations

The following figures show the available capacity and cooling options for the Liebert® Mini-Mate2.

Figure 3.1 Air Cooled Units

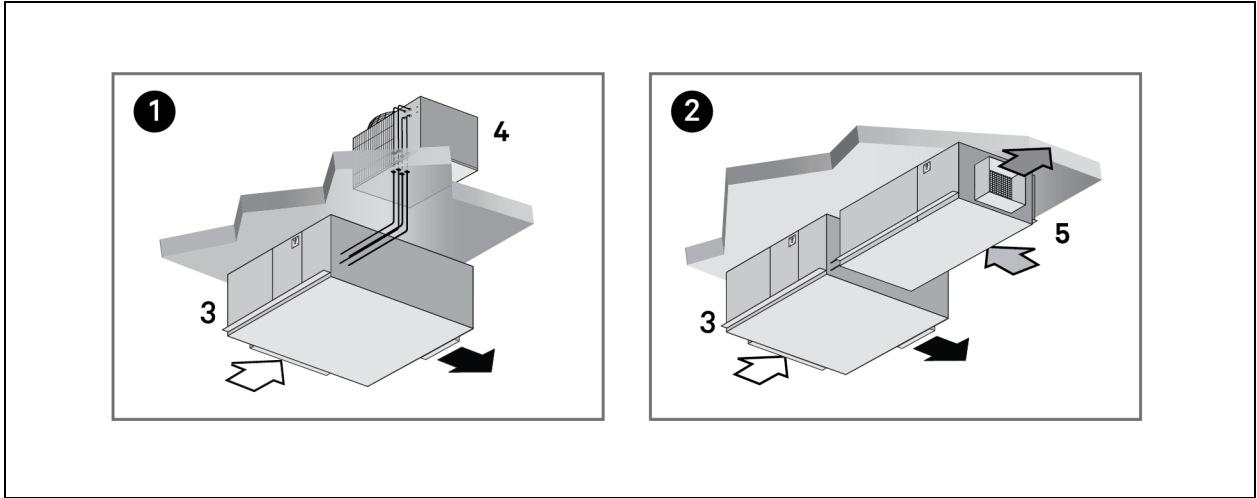

Item	Description
1	Split-system (outdoor condensing unit) with ducted supply/return air
2	Split system (indoor condensing unit) with ducted supply/return air
3	Evaporator
4	Outdoor air cooled condensing unit
5	Indoor air cooled condensing unit

Figure 3.2 Water/Glycol Cooled Units

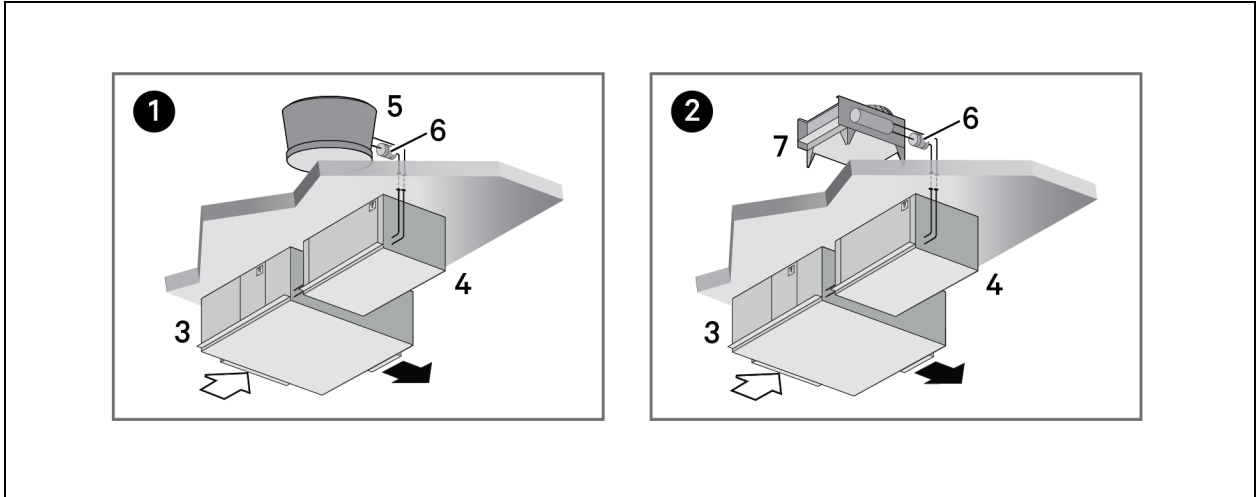

Item	Description
1	Split system water cooled with ducted supply/return air
2	Split system glycol cooled with ducted supply/return air
3	Evaporator
4	Water/Glycol condensing unit
5	Cooling tower
6	Pump
7	Drycooler

Figure 3.3 Chilled Water Units

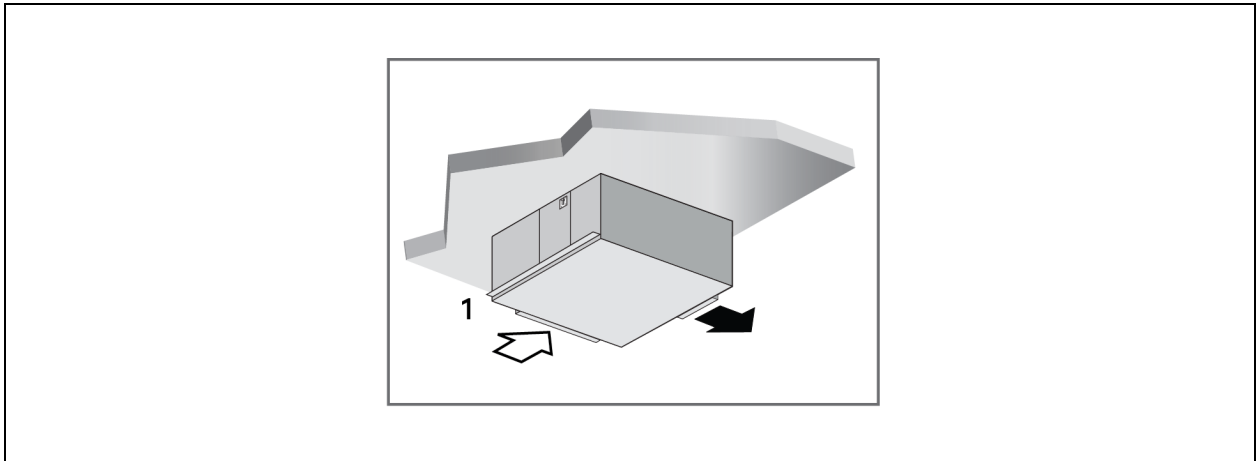

Item	Description
1	Chilled water unit with ducted supply/return air

## 3.2 Nomenclature for Evaporator and Chilled Water Units

Table 3.2 below describes each digit of the model number.

**Table 3.1 Nomenclature Example**

1	2	3	4	5	6	7	8	9	10	11	12
M	M	D	9	6	E	N	C	R	E	L	5

**Table 3.2 Nomenclature Digit Definitions for Evaporator and Chilled Water Units**

Digit	Description
Digits 1 and 2 = the base unit	MM = Vertiv™ Liebert® Mini-Mate2
Digit 3 = Disconnect	D = Disconnect switch
Digits 4, 5 = Nominal Capacity	96 = 96 kBtuh, 8-ton, 60 Hz 95 = 95 kBtuh, 8-ton, 50 Hz 8T = 8-ton, 60/50 Hz (chilled-water)
Digit 6 = Cooling type	E = Split-system evaporator (See <a href="#">Nomenclature for Split-system Condensing units</a> on page 15.) K = Split-system evaporator with free-cooling (See <a href="#">Nomenclature for Split-system Condensing units</a> on page 15.) C = Chilled-water
Digit 7 = Refrigerant/Valve type	N = R-407C field-supplied D = 2-way modulating chilled-water valve T = 3-way modulating chilled-water valve
Digit 8 = Supply power	A = 460 V / 3 ph / 60 Hz B = 575 V / 3 ph / 60 Hz C = 208 V / 3 ph / 60 Hz D = 230 V / 3 ph / 60 Hz M = 380/415 V / 3 ph / 50 Hz
Digit 9 = Humidification	R = Remote Humidifier Contact (without canister humidifier) J = Canister Humidifier and Remote Humidifier Contact

**Table 3.2 Nomenclature Digit Definitions for Evaporator and Chilled Water Units (continued)**

Digit	Description
Digit 10 = Reheat	<ul style="list-style-type: none"> <li>0 = No reheat</li> <li>E = Electric reheat</li> <li>S = SCR reheat (not available with free-cooling or chilled-water cooling types)</li> <li>H = Hot-water reheat (chilled-water systems only)</li> </ul>
Digit 11 = Blower type	<ul style="list-style-type: none"> <li>L = Low-static blower, 2-hp motor</li> <li>H = High-static blower, 3-hp motor</li> </ul>
Digit 12 = Sensor packages	<ul style="list-style-type: none"> <li>N = Base package of filter-clog and high-temperature sensor</li> <li>2 = Smoke sensor + Base package</li> <li>4 = Vertiv™ Liebert® IS-UNITY-DP (BMS) + Base Package</li> <li>5 = Liebert® IS-UNITY-DP (BMS) + Smoke sensor + Base package</li> </ul>

### 3.3 Nomenclature for Split-system Condensing units

This section describes the model-number configuration for Vertiv™ Liebert® Mini-Mate2 split-system condensing units.

#### 3.3.1 Indoor Condensing Units for Air Cooled Split Systems

[Nomenclature Digit Definitions for Indoor, Air Cooled Condensing Units](#) below describes each digit of the model number.

**Table 3.3 Indoor, Air Cooled Condensing Unit Nomenclature Example**

1	2	3	4	5	6	7	8	9	10
M	C	D	9	6	A	L	A	H	N

**Table 3.4 Nomenclature Digit Definitions for Indoor, Air Cooled Condensing Units**

Digit	Description
Digits 1 to 2 = the base unit	MC = Vertiv™ Liebert® Mini-Mate2 condensing unit
Digit 3 = Disconnect	D = Disconnect switch
Digit 4 and 5 = Nominal Capacity	96A = 96 kBtuh, 60 Hz 95A = 95 kBtuh, 50 Hz
Digit 6 = Cooling type	A = Air-cooled
Digit 7 = Head-pressure control	L = Vertiv™ Liebert® Lee-Temp Receiver
Digit 8 = Supply power	A = 460 V / 3 ph / 60 Hz B = 575 V / 3 ph / 60 Hz M = 380/415 V / 3 ph / 50 Hz Y = 208/230 V / 3 ph / 60 Hz
Digit 9 = Hot-gas bypass	H = Hot-gas bypass
Digit 10 = Refrigerant	N = R-407C field-charged

### 3.3.2 Outdoor Prop Fan Condensing Units for Air Cooled Split Systems

Nomenclature Digit Definitions for Outdoor, Prop Fan Condensing Units below describes each digit of the model number.

**Table 3.5 Prop Fan Condensing Unit Nomenclature Example**

1	2	3	4	5	6	7	8	9	10	11
P	F	H	0	9	6	A	—	A	L	N

**Table 3.6 Nomenclature Digit Definitions for Outdoor, Prop Fan Condensing Units**

Digit	Description
Digits 1 to 3 = the base unit	PFH = Prop-fan condensing unit with hot-gas bypass
Digit 4 = Sound level	0 = Standard
Digit 5 and 6 = Nominal Capacity	96 = 96 kBtuh, 60 Hz 95 = 95 kBtuh, 50 Hz
Digit 7 = Cooling type	A = Air-cooled
Digit 8 = Coil type	— = Standard coil C = Coated coil (epoxy with UV topcoat)
Digit 9 = Supply power	A = 460 V / 3 ph / 60 Hz B = 575 V / 3 ph / 60 Hz M = 380/415 V / 3 ph / 50 Hz Y = 208/230 V / 3 ph / 60 Hz
Digit 10 = Ambient rating/Control	L = 95°F Ambient, Vertiv™ Liebert® Lee-Temp
Digit 11 = Refrigerant	N = R-407C field-charged

### 3.3.3 Water/Glycol Cooled Condensing Units

Nomenclature Digit Definitions for Indoor, Water/Glycol Cooled Condensing Units below describes each digit of the model number.

**Table 3.7 Remote, Indoor Water/Glycol Condensing Unit Nomenclature Example**

1	2	3	4	5	6	7	8	9	10
M	C	D	9	8	W	2	A	H	N

**Table 3.8 Nomenclature Digit Definitions for Indoor, Water/Glycol Cooled Condensing Units**

Digit	Description
Digits 1 to 2 = the base unit	MC = Vertiv™ Liebert® Mini-Mate2 condensing unit
Digit 3 = Disconnect	D = Disconnect switch
Digit 4 and 5 = Nominal Capacity	98 = 98 kBtuh, 60 Hz 97 = 97 kBtuh, 50 Hz
Digit 6 = Cooling type	W = Water/Glycol-cooled
Digit 7 = Head-pressure control	2 = 2-way standard-pressure fluid-regulating valve 3 = 3-way standard-pressure fluid-regulating valve D = 2-way high-pressure fluid-regulating valve T = 3-way high-pressure fluid-regulating valve
Digit 8 = Supply power	A = 460 V / 3 ph / 60 Hz B = 575 V / 3 ph / 60 Hz M = 380/415 V / 3 ph / 50 Hz Y = 208/230 V / 3 ph / 60 Hz
Digit 9 = Hot-gas bypass	H = Hot-gas bypass
Digit 10 = Refrigerant	N = R-407C field-charged

This page intentionally left blank

## 4 System Data

### 4.1 Air Cooled Systems—Capacity and Performance Data

Table 4.1 Air Cooled Data, 60-Hz

Evaporator Model		MMD96E or MMD96K	
Condensing Unit Type		PFH - Outdoor	MCD - Indoor
<b>DX Evaporator- Net Capacity Data - kW (Btuh)</b>			
80°F DB, 62.8°F WB (26.7°C DB, 17.1°C WB) 38% RH	Total	28.4 (96,900)	28.1 (96,000)
	Sensible	27.9 (95,200)	27.8 (94,800)
75°F DB, 61°F WB (23.9°C DB, 16.1°C WB) 45% RH	Total	27.2 (92,700)	26.9 (91,800)
	Sensible	24.9 (84,900)	24.9 (84,800)
72°F DB, 60°F WB (22.2°C DB, 15.5°C WB) 50% RH	Total	26.5 (90,400)	26.3 (89,700)
	Sensible	22.8 (77,900)	22.8 (77,700)
<b>Fan Data - Evaporator</b>			
CFM (CMH)		3750 (6371)	
Fan Motor, hp (W)		2.0 (1491)	
External Static Pressure, in. (mm) water gauge		0.5 (13)	
<b>Evaporator Coil - Copper Tube/Aluminum Fin</b>			
Face Area ft. <sup>2</sup> (m <sup>2</sup> )		7.6 (0.71)	
Coil Rows		4	
Max Face Velocity-fpm (m/s)		491 (2.5)	
Unit Refrigerant Charge (5-Ton Circuit), oz. (kg)		7 (0.20)	
Unit Refrigerant Charge (3-Ton Circuit), oz. (kg)		7 (0.20)	
Unit Operating Weight, lb. (kg)		665 (302)	
<b>Electric Reheat Capacity (Includes Fan Motor)-kW (Btuh)</b>			
All Voltages		11.5 (39,200)	
<b>SCR Reheat Capacity (Includes Fan Motor)-kW (Btuh)</b>			
All Voltages, except 575-3-60		16.5 (56,300)	
<b>Humidifier Data - Steam Generator Type</b>			
Steam capacity, lb./hr (kg/hr)		10 (4.5)	
Electrical Input Power - kW		3.5	
<b>Evaporator Connection Sizes</b>			
Liquid line Diameter (5-ton circuit), O.D. Cu		1/2"	
Suction Line Diameter (5-ton circuit), O.D. Cu		7/8"	

**Table 4.1 Air Cooled Data, 60-Hz (continued)**

Evaporator Model	MMD96E or MMD96K	
Condensing Unit Type	PFH - Outdoor	MCD - Indoor
Liquid line Diameter (3-ton circuit), O.D. Cu	3/8"	
Suction Line Diameter (3-ton circuit), O.D. Cu	7/8"	
Humidifier Supply	1/4" OD Cu Compression Fitting	
Evaporator/Condensate Drain	3/4" NPT-Female	
MERV 8 Filter - Nominal Size, qty 2; in. (mm)	4x20x25 (102x508x635)	
Condensing Unit Model Number	PFH096A-_LN	MCD96AL_HN
Condensing Unit Rating Conditions	95°F (35°C) Ambient	
Coil Face Area ft. <sup>2</sup> (m <sup>2</sup> )	21 (1.95)	10.4 (0.97)
Rows of Coil	3	4
CFM (CMH)	6480 (11010)	5000 (8495)
Motor, hp (W)	0.75 (560)	3.0 (22)
External Static Pressure, in wg. (mm)	N/A	0.50 (13)
Unit Refrigerant Charge (5-Ton Circuit), oz. (kg)	581 (16.5)	402 (11.4)
Unit Refrigerant Charge (3-Ton Circuit), oz. (kg)	361 (10.2)	210 (6.0)
Unit Operating Weight, lb. (kg)	565 (257)	530 (241)
Condensing Unit Connection Sizes		
Liquid line Diameter (5-ton circuit), O.D. Cu	1/2"	1/2"
Suction Line Diameter (5-ton circuit), O.D. Cu	7/8"	7/8"
Liquid line Diameter (3-ton circuit), O.D. Cu	3/8"	3/8"
Suction Line Diameter (3-ton circuit), O.D. Cu	7/8"	7/8"
Free Cooling Coil Option Net Capacity Data - kW (Btuh) using 45°F (7.2°C) EWT		
80°F DB, 62.8°F WB (26.7°C DB, 17.1°C WB) 38% RH	Total	28.0 (95,600)
	Sensible	26.8 (91,500)
75°F DB, 61°F WB (23.9°C DB, 16.1°C WB) 45% RH	Total	24.1 (82,200)
	Sensible	22.5 (76,800)
72°F DB, 60°F WB (22.2°C DB, 15.5°C WB) 50% RH	Total	21.7 (74,100)
	Sensible	19.9 (67,900)
Flow Rate - GPM (l/m)	17.6 (66.7)	
Pressure Drop - ft. water (kPa)	9.9 (29.6)	
Free Cooling Coil - Copper Tube/Aluminum Fin		
Face Area ft. <sup>2</sup> (m <sup>2</sup> )	7.6 (0.7)	
Coil Rows	4	

**Table 4.1 Air Cooled Data, 60-Hz (continued)**

Evaporator Model	MMD96E or MMD96K	
Condensing Unit Type	PFH - Outdoor	MCD - Indoor
Max Face Velocity-fpm (m/s)	444 (226)	
Internal Fluid Volume - gal (l)	2.6 (9.8)	
Free Cooling Coil Supply and Return Connections, in. O.D. Cu	1-3/8	
The net capacity data has fan motor heat factored in for all ratings and the entering air conditions of 75°F (23.9°C), 45% RH, is the standard rating condition for ASHRAE 127-2007. All capacities are nominal values; actual performance will be ±5%.		

**Table 4.2 Air Cooled Data, 50Hz**

Evaporator Model	MMD95E or MMD95K		
Condensing Unit Type	PFH - Outdoor	MCD - Indoor	
<b>DX Evaporator- Net Capacity Data - kW (Btuh)</b>			
80°F DB, 62.8°F WB (26.7°C DB, 17.1°C WB) 38% RH	Total	27.9 (95,100)	27.6 (94,200)
	Sensible	27.5 (94,000)	27.3 (93,300)
75°F DB, 61°F WB (23.9°C DB, 16.1°C WB) 45% RH	Total	26.6 (90,600)	26.3 (89,900)
	Sensible	24.6 (84,100)	24.5 (83,700)
72°F DB, 60°F WB (22.2°C DB, 15.5°C WB) 50% RH	Total	25.9 (88,400)	25.7 (87,700)
	Sensible	22.7 (77,300)	22.5 (76,900)
<b>Fan Data - Evaporator</b>			
CFM (CMH)	3750 (6371)		
Fan Motor, hp (W)	2.0 (1491)		
External Static Pressure, in. (mm) water gauge	0.5 (13)		
<b>Evaporator Coil - Copper Tube/Aluminum Fin</b>			
Face Area, ft. <sup>2</sup> (m <sup>2</sup> )	7.6 (0.71)		
Coil Rows	4		
Max Face Velocity, fpm (m/s)	491 (2.5)		
Unit Refrigerant Charge (5-Ton Circuit), oz. (kg)	7 (0.20)		
Unit Refrigerant Charge (3-Ton Circuit), oz. (kg)	7 (0.20)		
Unit Operating Weight, lb. (kg)	665 (302)		
<b>Electric Reheat Capacity (Includes Fan Motor)-kW (Btuh)</b>			
All Voltages	10.5 (35,900)		
<b>SCR Reheat Capacity (Includes Fan Motor)-kW (Btuh)</b>			
All Voltages, except 575-3-60	15 (51,300)		
<b>Humidifier Data - Steam Generator Type</b>			
Steam capacity, lb./hr (kg/hr)	10 (4.5)		

Table 4.2 Air Cooled Data, 50Hz (continued)

Evaporator Model	MMD95E or MMD95K	
Condensing Unit Type	PFH - Outdoor	MCD - Indoor
Electrical Input Power, kW	3.5	
<b>Evaporator Connection Sizes</b>		
Liquid line Diameter (5-ton circuit), O.D. Cu	1/2"	
Suction Line Diameter (5-ton circuit), O.D. Cu	7/8"	
Liquid line Diameter (3-ton circuit), O.D. Cu	3/8"	
Suction Line Diameter (3-ton circuit), O.D. Cu	7/8"	
Humidifier Supply	1/4" OD Cu Compression Fitting	
Evaporator/Condensate Drain	3/4" NPT-Female	
MERV 8 Filter - Nominal Size, qty 2; in. (mm)	4x20x25 (102x508x635)	
<b>Condensing Unit Model Number</b>	PFH095A-_LN	MCD95AL_HN
Condensing Unit Rating Conditions	95°F (35°C) Ambient	
Coil Face Area, ft. <sup>2</sup> (m <sup>2</sup> )	21 (1.95)	10.4 (0.97)
Rows of Coil	3	4
CFM (CMH)	5400 (9175)	5000 (8495)
Motor, hp (W)	0.75 (560)	3.0 (2.2)
External Static Pressure, in wg. (mm)	N/A	0.50 (13)
Unit Refrigerant Charge (5-Ton Circuit), oz. (kg)	581 (16.5)	402 (11.4)
Unit Refrigerant Charge (3-Ton Circuit), oz. (kg)	361 (10.2)	210 (6.0)
Unit Operating Weight, lb. (kg)	565 (257)	530 (241)
<b>Condensing Unit Connection Sizes</b>		
Liquid line Diameter (5-ton circuit), O.D. Cu	1/2"	1/2"
Suction Line Diameter (5-ton circuit), O.D. Cu	7/8"	7/8"
Liquid line Diameter (3-ton circuit), O.D. Cu	3/8"	3/8"
Suction Line Diameter (3-ton circuit), O.D. Cu	7/8"	7/8"
<b>Free Cooling Coil Option Net Capacity Data - kW (Btuh) using 45°F (7.2°C) EWT</b>		
80°F DB, 62.8°F WB (26.7°C DB, 17.1°C WB) 38% RH	Total	28.0 (95,600)
	Sensible	26.8 (91,500)
75°F DB, 61°F WB (23.9°C DB, 16.1°C WB) 45% RH	Total	24.1 (82,200)
	Sensible	22.5 (76,800)
72°F DB, 60°F WB (22.2°C DB, 15.5°C WB) 50% RH	Total	21.7 (74,100)
	Sensible	19.9 (67,900)
Flow Rate, GPM (l/m)	17.6 (66.7)	

Table 4.2 Air Cooled Data, 50Hz (continued)

Evaporator Model	MMD95E or MMD95K	
Condensing Unit Type	PFH - Outdoor	MCD - Indoor
Pressure Drop, ft. water (kPa)	9.9 (29.6)	
<b>Free Cooling Coil - Copper Tube/Aluminum Fin</b>		
Face Area ft. <sup>2</sup> (m <sup>2</sup> )	7.6 (0.7)	
Coil Rows	4	
Max Face Velocity, fpm (m/s)	444 (2.26)	
Internal Fluid Volume, gal (l)	2.6 (9.8)	
Free Cooling Coil supply and return connections, in. O.D. > Cu	1-3/8	
The net capacity data has fan motor heat factored in for all ratings and the entering air conditions of 75°F (23.9°C), 45% RH, is the standard rating condition for ASHRAE 127-2007. All capacities are nominal values; actual performance will be ±5%.		

## 4.2 Water/Glycol Cooled Systems—Capacity and Performance Data

Table 4.3 Water/Glycol Data, 60-Hz

Evaporator Model	MMD96E or MMD96K		
Condensing Unit Fluid	Water Cooled	Glycol Cooled	
<b>DX Evaporator- Net Capacity Data - kW (Btuh)</b>			
80°F DB, 62.8°F WB (26.7°C DB, 17.1°C WB) 38% RH	Total	31.1 (106,000)	27.0 (92,000)
	Sensible	29.6 (101,000)	26.8 (91,600)
75°F DB, 61°F WB (23.9°C DB, 16.1°C WB) 45% RH	Total	29.9 (102,000)	25.6 (87,500)
	Sensible	26.2 (89,400)	24.2 (82,400)
72°F DB, 60°F WB (22.2°C DB, 15.5°C WB) 50% RH	Total	29.2 (99,800)	24.9 (85,100)
	Sensible	24.2 (82,600)	22.2 (75,600)
<b>Fan Data - Evaporator</b>			
CFM (CMH)	3750 (6371)		
Fan Motor HP (W)	2.0 (1491)		
External Static Pressure, in. (mm) water gauge	0.5 (13)		
<b>Evaporator Coil - Copper Tube/Aluminum Fin</b>			
Face Area ft. <sup>2</sup> (m <sup>2</sup> )	7.6 (0.71)		
Coil Rows	4		
Max Face Velocity, fpm (m/s)	491 (2.5)		
Unit Refrigerant Charge (5-Ton Circuit), oz. (kg)	7 (0.20)		
Unit Refrigerant Charge (3-Ton Circuit), oz. (kg)	7 (0.20)		
Unit Operating Weight, lb. (kg)	665 (302)		

Table 4.3 Water/Glycol Data, 60-Hz (continued)

Evaporator Model	MMD96E or MMD96K	
Condensing Unit Fluid	Water Cooled	Glycol Cooled
<b>Electric Reheat Capacity (Includes Fan Motor)-kW (Btuh)</b>		
All Voltages	11.5 (39,200)	
<b>SCR Reheat Capacity (Includes Fan Motor)-kW (Btuh)</b>		
All Voltages, except 575-3-60	16.5 (56,300)	
<b>Humidifier Data - Steam Generator Type</b>		
Steam capacity, lb./hr (kg/hr)	10 (4.5)	
Electrical Input Power, kW	3.5	
<b>Evaporator Connection Sizes</b>		
Liquid line Diameter (5-ton circuit), O.D. Cu	1/2"	
Suction Line Diameter (5-ton circuit), O.D. Cu	7/8"	
Liquid line Diameter (3-ton circuit), O.D. Cu	3/8"	
Suction Line Diameter (3-ton circuit), O.D. Cu	7/8"	
Humidifier Supply	1/4" OD Cu Compression Fitting	
Evaporator/Condensate Drain	3/4" NPT-Female	
MERV 8 Filter - Nominal Size, qty 2; in. (mm)	4x20x25 (102x508x635)	
<b>Condensing Unit Model Number</b>		
MCD98W_AHN		
Condenser Fluid Requirements	85°F (29.4°C) EWT	110°F (43.3°C) EGT - 40% PG
THR - kW (Btuh) @ 75F/45%RH	38.4 (131,000)	36.6 (125,000)
Flow Rate, GPM (l/m)	22.7 (86.0)	32.6 (123.6)
Pressure Drop, ft. of H2O (kPa)	19.2 (57.4)	45.8 (136.9)
Water-Cooled Condensing Temperature	105°F (40.6°C)	N/A
Unit Volume, Gal (l)	4.0 (15.1)	
Unit Refrigerant Charge (5-Ton Circuit), oz. (kg)	94 (2.7)	
Unit Refrigerant Charge (3-Ton Circuit), oz. (kg)	54 (1.5)	
Water/Glycol Connection Sizes, in. O.D. Cu	1-3/8	
Unit Operating Weight, lb. (kg)	470 (213)	
<b>Condensing Unit Connection Sizes</b>		
Liquid line Diameter (5-ton circuit), O.D. Cu	1/2"	1/2"
Suction Line Diameter (5-ton circuit), O.D. Cu	7/8"	7/8"
Liquid line Diameter (3-ton circuit), O.D. Cu	3/8"	3/8"
Suction Line Diameter (3-ton circuit), O.D. Cu	7/8"	7/8"
<b>Free Cooling Coil Option Net Capacity Data - kW (Btuh) using 45°F (7.2°C) EWT</b>		

Table 4.3 Water/Glycol Data, 60-Hz (continued)

Evaporator Model		MMD96E or MMD96K	
Condensing Unit Fluid		Water Cooled	Glycol Cooled
Entering Fluid Conditions		45°F (7.2°C) EWT	45°F (7.2°C) EGT - 40% PG
80°F DB, 62.8°F WB (26.7°C DB, 17.1°C WB) 38% RH	Total	28.0 (95,600)	20.8 (71,000)
	Sensible	26.8 (91,500)	20.8 (71,000)
75°F DB, 61°F WB (23.9°C DB, 16.1°C WB) 45% RH	Total	24.1 (82,200)	17.6 (60,100)
	Sensible	22.5 (76,800)	17.6 (60,100)
72°F DB, 60°F WB (22.2°C DB, 15.5°C WB) 50% RH	Total	21.7 (74,100)	15.7 (53,500)
	Sensible	19.9 (67,900)	15.7 (53,500)
Flow Rate - GPM (l/m)		17.6 (66.7)	32.6 (123.6)
Pressure Drop - ft. water (kPa)		9.9 (29.6)	47.3 (141.4)
<b>Free Cooling Coil - Copper Tube/Aluminum Fin</b>			
Face Area, ft. <sup>2</sup> (m <sup>2</sup> )		7.6 (0.7)	
Coil Rows		4	
Max Face Velocity, fpm (m/s)		444 (2.26)	
Internal Fluid Volume - gal (l)		2.6 (9.8)	
Free Cooling Coil Supply and Return Connections, in. O.D. Cu		1-3/8	
The net capacity data has fan motor heat factored in for all ratings and the entering air conditions of 75°F (23.9°C), 45% RH, is the standard rating condition for ASHRAE 127-2007. All capacities are nominal values; actual performance will be ±5%.			

Table 4.4 Water/Glycol Data, 50-Hz

Evaporator Model		MMD95E or MMD95K	
Condensing Unit Fluid		Water Cooled	Glycol Cooled
<b>DX Evaporator- Net Capacity Data - kW (Btuh)</b>			
80°F DB, 62.8°F WB (26.7°C DB, 17.1°C WB) 38% RH	Total	30.5 (104,000)	26.5 (90,300)
	Sensible	29.2 (99,600)	26.4 (90,100)
75°F DB, 61°F WB (23.9°C DB, 16.1°C WB) 45% RH	Total	29.3 (100,000)	25.1 (85,600)
	Sensible	25.9 (88,500)	23.9 (81,500)
72°F DB, 60°F WB (22.2°C DB, 15.5°C WB) 50% RH	Total	28.7 (98,000)	24.4 (83,200)
	Sensible	23.9 (81,600)	21.9 (74,800)
<b>Fan Data - Evaporator</b>			
CFM (CMH)		3750 (6371)	
Fan Motor HP (W)		2.0 (1491)	
External Static Pressure, in. (mm) water gauge		0.5 (13)	
<b>Evaporator Coil - Copper Tube/Aluminum Fin</b>			
Face Area ft. <sup>2</sup> (m <sup>2</sup> )		7.6 (0.71)	

**Table 4.4 Water/Glycol Data, 50-Hz (continued)**

Evaporator Model	MMD95E or MMD95K	
Condensing Unit Fluid	Water Cooled	Glycol Cooled
Coil Rows	4	
Max Face Velocity-fpm (m/s)	491 (2.5)	
Unit Refrigerant Charge (5-Ton Circuit), oz. (kg)	7 (0.20)	
Unit Refrigerant Charge (3-Ton Circuit), oz. (kg)	7 (0.20)	
Unit Operating Weight, lb. (kg)	665 (302)	
<b>Electric Reheat Capacity (Includes Fan Motor)-kW (Btuh)</b>		
All Voltages	10.5 (35,900)	
<b>SCR Reheat Capacity (Includes Fan Motor)-kW (Btuh)</b>		
All Voltages, except 575-3-60	15 (51,300)	
<b>Humidifier Data - Steam Generator Type</b>		
Steam capacity, lb./hr (kg/hr)	10 (4.5)	
Electrical Input Power, kW	3.5	
<b>Evaporator Connection Sizes</b>		
Liquid line Diameter (5-ton circuit), O.D. Cu	1/2"	
Suction Line Diameter (5-ton circuit), O.D. Cu	7/8"	
Liquid line Diameter (3-ton circuit), O.D. Cu	3/8"	
Suction Line Diameter (3-ton circuit), O.D. Cu	7/8"	
Humidifier Supply	1/4" OD Cu Compression Fitting	
Evaporator/Condensate Drain	3/4" NPT-Female	
MERV 8 Filter - Nominal Size, qty 2; in. (mm)	4x20x25 (102x508x635)	
<b>Condensing Unit Model Number</b>		
MCD97W_AHN		
Condenser Fluid Requirements	85°F (29.4°C) EWT	110°F (43.3°C) EGT - 40% PG
THR - kW (Btuh) @ 75F/45%RH	37.5 (128,000)	35.8 (122,000)
Flow Rate, GPM (l/m)	28.3 (107.3)	32.8 (124.3)
Pressure Drop, ft. of H2O (kPa)	19 (56.8)	46.4 (138.7)
Water Cooled Condensing Temperature	105°F (40.6°C)	N/A
Unit Volume, Gal (l)	4.0 (15.1)	
Unit Refrigerant Charge (5-Ton Circuit), oz. (kg)	94 (2.7)	
Unit Refrigerant Charge (3-Ton Circuit), oz. (kg)	54 (1.5)	
<b>Condensing Unit Connection Sizes</b>		
Liquid line Diameter (5-ton circuit), O.D. Cu	1/2"	
Suction Line Diameter (5-ton circuit), O.D. Cu	7/8"	

**Table 4.4 Water/Glycol Data, 50-Hz (continued)**

Evaporator Model		MMD95E or MMD95K	
Condensing Unit Fluid		Water Cooled	Glycol Cooled
Liquid line Diameter (3-ton circuit), O.D. Cu		3/8"	
Suction Line Diameter (3-ton circuit), O.D. Cu		7/8"	
Water/Glycol Connection Sizes, in. O.D. Cu		1-3/8	
Unit Operating Weight, lb. (kg)		470 (213)	
Free Cooling Coil Option Net Capacity Data - kW (Btuh) using 45°F (7.2°C) EWT			
Entering Fluid Conditions		45°F (7.2°C) EWT	45°F (7.2°C) EGT - 40% PG
80°F DB, 62.8°F WB (26.7°C DB, 17.1°C WB) 38% RH	Total	28.0 (95,600)	20.9 (71,200)
	Sensible	26.8 (91,500)	20.9 (71,200)
75°F DB, 61°F WB (23.9°C DB, 16.1°C WB) 45% RH	Total	24.1 (82,200)	17.6 (60,200)
	Sensible	22.5 (76,800)	17.6 (60,200)
72°F DB, 60°F WB (22.2°C DB, 15.5°C WB) 50% RH	Total	21.7 (74,100)	15.7 (53,600)
	Sensible	19.9 (67,900)	15.7 (53,600)
Flow Rate, GPM (l/m)		17.6 (66.7)	32.8 (124.3)
Pressure Drop, ft. water (kPa)		9.9 (29.6)	47.8 (142.9)
Free Cooling Coil - Copper Tube/Aluminum Fin			
Face Area, ft. <sup>2</sup> (m <sup>2</sup> )		7.6 (0.7)	
Coil Rows		4	
Max Face Velocity, fpm (m/s)		444 (2.26)	
Internal Fluid Volume, gal (l)		2.6 (9.8)	
Free Cooling Coil Supply and Return Connections, in. O.D. Cu		1-3/8	
The net capacity data has fan motor heat factored in for all ratings and the entering air conditions of 75°F (23.9°C), 45% RH, is the standard rating condition for ASHRAE 127-2007. All capacities are nominal values; actual performance will be ±5%.			

## 4.3 Chilled Water Systems—Capacity and Performance Data

Table 4.5 Chilled Water Data, 50-Hz and 60-Hz

Model Number	MMD8TC	
<b>Net Capacity Data - kW (Btuh) based on 45°F (7.2°C) EWT &amp; 10°F (5.6°C) temperature rise</b>		
80°F DB, 62.8°F WB (26.7°C DB, 17.1°C WB) 38% RH	Total	29.8 (101,800)
	Sensible	27.9 (95,100)
Flow Rate, GPM (l/m)		21.4 (81.1)
Pressure Drop, ft. water (kPa)		14.7 (44.0)
75°F DB, 61°F WB (23.9°C DB, 16.1°C WB) 45% RH	Total	24.0 (82,000)
	Sensible	22.5 (76,700)
Flow Rate, GPM (l/m)		17.6 (66.7)
Pressure Drop, ft. water (kPa)		10.1 (30.2)
72°F DB, 60°F WB (22.2°C DB, 15.5°C WB) 50% RH	Total	20.5 (69,900)
	Sensible	19.1 (65,300)
Flow Rate, GPM (l/m)		15.1 (57.2)
Pressure Drop, ft. water (kPa)		7.5 (22.4)
<b>Fan Data - Evaporator</b>		
CFM (CMH)		3750 (6371)
Fan Motor, hp (kW)		2 (1.5)
External Static Pressure, in. (mm) water gauge		0.5 (13)
<b>CW Coil - Copper Tube/Aluminum Fin</b>		
Face Area, ft. <sup>2</sup> (m <sup>2</sup> )		7.6 (0.7)
Coil Rows		4
Max Face Velocity, fpm (m/s)		491 (2.5)
<b>Electric Reheat Capacity (Includes Fan Motor)-kW (Btuh)</b>		
Input Voltage-208/230/460/575-3-60		11.5 (39,110)
Input Voltage-380-3-50		10.5 (35,780)
Input Voltage-400-3-50		11.5 (39,110)
<b>Hot Water Reheat Coil - Copper Tube/Aluminum Fin</b>		
Capacity (with fan motor heat) using 180°F (82°C) EWT, kW (Btuh)		32.5 (110,800)
Flow Rate, GPM (l/m)		3.0 (11.4)
Pressure Drop, ft. water (kPa)		1.2 (3.6)
Face Area, ft. <sup>2</sup> (m <sup>2</sup> )		7.6 (0.7)
Coil Rows		1

**Table 4.5 Chilled Water Data, 50-Hz and 60-Hz (continued)**

Model Number	MMD8TC
HWRH Supply and Return Connections, in. O.D. Cu	7/8
<b>Humidifier Data - Steam Generator Type</b>	
Steam Capacity, lb/hr (kg/hr)	10 (4.5)
Electrical Input Power, kW	3.5
<b>Unit Connection Sizes</b>	
CW Supply and Return Connections, in. O.D. Cu	1-3/8
Humidifier Supply	1/4" OD Cu Compression Fitting
Evaporator/Condensate Drain	3/4" NPT-Female
Unit Internal Fluid Volume, gal (l)	2.6 (9.8)
MERV 8 Filter - Nominal Size, qty 2, in. (mm)	4x20x25 (102x508x635)
Unit Operating Weight	665 (302)
Unit Valve Type	Modulating, Non-Spring Return
Valve Size	1"
Valve Cv	11.6
Max. Static Operating Pressure, psi (kPa)	400 (2758)
Close-Off Pressure, psi (kPa)	86 (592)
The net capacity data has fan motor heat factored in for all ratings and the entering air conditions of 75°F (23.9°C), 45% RH, is the standard rating condition for ASHRAE 127-2007. All capacities are nominal values; actual performance will be ±5%.	

**Table 4.6 Capacity Correction Factors, Based On 10°F (5.6°C) Water Rise**

Return Air Conditions	72°F (22.2°C) 50%RH		75°F (23.9°C) 45%RH	
	Total	Sensible	Total	Sensible
42°F (5.6°C)	1.27	1.14	1.24	1.12
43°F (6.1°C)	1.18	1.09	1.16	1.08
44°F (6.7°C)	1.08	1.05	1.07	1.04
45°F (7.2°C)	1.00	1.00	1.00	1.00
46°F (7.8°C)	0.93	0.95	0.94	0.96
47°F (8.3°C)	0.85	0.91	0.87	0.93
48°F (8.9°C)	0.80	0.85	0.82	0.88
49°F (9.4°C)	0.74	0.79	0.77	0.83

## 4.4 Planning Dimensions

The unit dimensions are described in the submittal documents included in the [Submittal Drawings](#) on page 49.

The following table lists the relevant documents by number and title.

**Table 4.7 Dimension Planning Drawings**

Document Number	Title
<b>Split System Evaporators/Chilled Water Units</b>	
DPN000240	Evaporator/Chilled Water Unit and Filter Box Option Dimensions
<b>Outdoor Condensing Units</b>	
DPN004419	Cabinet Dimensions, Prop Fan Condensing Unit with top air discharge
<b>Indoor Condensing Units</b>	
DPN004424	Cabinet Dimensions, Air Cooled units
DPN004425	Cabinet Dimensions, Water/Glycol-cooled units

## 5 Electrical Data

### 5.1 Evaporators and Chilled Water Units Electrical Data

Table 5.1 Split System Evaporator or Chilled Water Unit Electrical Data, Standard 2-hp Motor, 60-Hz and 50-Hz

	60 Hz				50 Hz
	208-3-60	230-3-60	460-3-60	575-3-60	380/415-3-50
Base Evaporator Model	MMD96E	MMD96E	MMD96E	MMD96E	MMD95E
Base Chilled Water Model	MMD8TC	MMD8TC	MMD8TC	MMD8TC	MMD8TC
<b>Cooling Only</b>					
FLA	6.3	6.3	3.1	2.7	3.7
WSA	7.9	7.9	3.9	3.4	N/A
OPD	15	15	15	15	N/A
<b>With Electric Reheat</b>					
FLA	34.1	31.4	15.7	12.7	18.1
WSA	42.6	39.3	19.6	15.9	N/A
OPD	45	40	20	20	N/A
<b>With SCR Reheat</b>					
FLA	47.9	44.0	21.9	N/A	25.4
WSA	59.9	55.0	27.4	N/A	N/A
OPD	60	60	30	N/A	N/A
<b>With Humidifier</b>					
FLA	18.1	16.9	8.4	7.0	9.8
WSA	22.6	21.1	10.5	8.8	N/A
OPD	25	25	15	15	N/A
<b>With Electric Reheat and Humidifier</b>					
FLA	45.9	42.0	21.0	17.0	24.2
WSA	57.4	52.5	26.3	21.3	N/A
OPD	60	60	30	25	N/A
<b>With SCR Reheat and Humidifier</b>					
FLA	59.7	54.6	27.2	N/A	31.5
WSA	74.6	68.3	34.0	N/A	N/A
OPD	80	70	35	N/A	N/A
FLA = Full Load Amps, WSA = Wire Size Amps, OPD = Maximum Overcurrent Protection Device					

**Table 5.1 Split System Evaporator or Chilled Water Unit Electrical Data, Standard 2-hp Motor, 60-Hz and 50-Hz (continued)**

	60 Hz				50 Hz
	208-3-60	230-3-60	460-3-60	575-3-60	380/415-3-50
<b>Base Evaporator Model</b>	MMD96E	MMD96E	MMD96E	MMD96E	MMD95E
<b>Base Chilled Water Model</b>	MMD8TC	MMD8TC	MMD8TC	MMD8TC	MMD8TC
<p>For Hot Water Reheat (available on MMD8TC units only), use appropriate "Cooling Only" or "with humidifier" categories.</p> <p>For MMD96K/MMD95K electrical data, use appropriate MMD96E/MMD95E data (except SCR reheat is not available with free cooling option)SCR Reheat not available on MMD96K, MMD95K, or MMD8TC.</p>					

Table 5.2 Split System Evaporator or Chilled Water Unit Electrical Data, Optional 3-hp Motor, 60-Hz and 50-Hz

	60 Hz				50 Hz
	208-3-60	230-3-60	460-3-60	575-3-60	380/415-3-50
Base Evaporator Model #	MMD96E	MMD96E	MMD96E	MMD96E	MMD95E
Base Chilled Water Model #	MMD8TC	MMD8TC	MMD8TC	MMD8TC	MMD8TC
<b>Cooling Only</b>					
FLA	9.7	9.0	4.5	3.6	4.8
WSA	12.1	11.3	5.6	4.5	N/A
OPD	20	20	15	15	N/A
<b>With Electric Reheat</b>					
FLA	37.5	34.1	17.1	13.6	19.2
WSA	46.9	42.6	21.4	17.0	N/A
OPD	50	45	25	20	N/A
<b>With SCR Reheat</b>					
FLA	51.3	46.7	23.3	N/A	26.5
WSA	64.1	58.4	29.1	N/A	N/A
OPD	70	60	30	N/A	N/A
<b>With Humidifier</b>					
FLA	21.5	19.6	9.8	7.9	10.9
WSA	26.9	24.5	12.3	9.9	N/A
OPD	30	30	15	15	N/A
<b>With Electric Reheat and Humidifier</b>					
FLA	49.3	44.7	22.4	17.9	25.3
WSA	61.6	55.9	28.0	22.4	N/A
OPD	70	60	30	25	N/A
<b>With SCR Reheat and Humidifier</b>					
FLA	63.1	57.3	28.6	N/A	32.6
WSA	78.9	71.6	35.8	N/A	N/A
OPD	80	80	40	N/A	N/A
FLA = Full Load Amps, WSA = Wire Size Amps, OPD = Maximum Overcurrent Protection Device					
For Hot Water Reheat (available on MMD8TC units only), use appropriate "Cooling Only" or "with humidifier" categories.					
For MMD96K/MMD95K electrical data, use appropriate MMD96E/MMD95E data (except SCR reheat is not available with free-cooling option) SCR Reheat not available on MMD96K, MMD95K, or MMD8TC.					

## 5.2 Indoor Condensing Units Electrical Data

Table 5.3 Indoor Air Cooled Condensing Unit Electrical Data

Model Number	60Hz			50Hz
	MCD96A	MCD96A	MCD96A	MCD95A
	208/230-3-60	460-3-60	575-3-60	380/415-3-50
FLA	42.4	20.9	15.6	21.2
WSA	47.6	23.4	17.5	N/A
OPD	60	30	20	N/A

Table 5.4 Indoor Water/Glycol Cooled Condensing Unit Electrical Data

Model Number	60Hz			50Hz
	MCD98W	MCD98W	MCD98W	MCD97W
	208/230-3-60	460-3-60	575-3-60	380/415-3-50
FLA	32.7	16.4	12.0	16.4
WSA	37.9	18.9	13.9	N/A
OPD	50	25	20	N/A

## 5.3 Outdoor Condensing Units Electrical Data

Table 5.5 Outdoor Prop Fan Condensing Units Electrical Data

Model Number	60Hz			50Hz
	PFH096A	PFH096A	PFH096A	PFH095A
	208/230-3-60	460-3-60	575-3-60	380/415-3-50
FLA	36.2	18.1	13.4	18.1
WSA	41.4	20.6	15.3	—
OPD	60	30	20	—

FLA = Full Load Amps; WSA = Wire Size Amps; OPD = Maximum Overcurrent Protection Device

## 5.4 Electrical Data for Air-cooled Systems Using a Single-point Power Kit

Table 5.6 Air-cooled Using Single-point power kit, Standard 2-hp motor

	60 Hz				50 Hz
	208-3-60	230-3-60	460-3-60	575-3-60	380/415-3-50
Base Evaporator Model Number	MMD96E	MMD96E	MMD96E	MMD96E	MMD95E
Base Condensing Unit Model Number	MCD96A	MCD96A	MCD96A	MCD96A	MCD95A
<b>Cooling Only</b>					
FLA	48.7	48.7	24.0	18.3	24.9
WSA	53.9	53.9	26.5	20.2	N/A
OPD	70	70	35	25	N/A
<b>With Electric Reheat</b>					
FLA	76.5	73.8	36.6	28.3	39.3
WSA	88.6	85.3	42.3	32.7	N/A
OPD	100	90	45	35	N/A
<b>With SCR Reheat</b>					
FLA	90.3	86.4	42.8	N/A	46.6
WSA	105.9	101.0	50.0	N/A	N/A
OPD	110	110	60	N/A	N/A
<b>With Humidifier</b>					
FLA	60.5	59.3	29.3	22.6	31.0
WSA	65.7	64.5	31.8	24.5	N/A
OPD	80	80	40	30	N/A
<b>With Electric Reheat and Humidifier</b>					
FLA	76.5	73.8	36.6	28.3	39.3
WSA	88.6	85.3	42.3	32.7	N/A
OPD	100	90	45	35	N/A
<b>With SCR Reheat and Humidifier</b>					
FLA	102.1	97.0	48.1	N/A	52.7
WSA	117.7	111.6	55.3	N/A	N/A
OPD	125	125	60	N/A	N/A
FLA = Full Load Amps, WSA = Wire Size Amps, OPD = Maximum Overcurrent Protection Device					
For MMD96K/MMD95K electrical data, use appropriate MMD96E/MMD95E data (except SCR reheat is not available with free cooling option).					

**Table 5.7 Air Cooled Using Single-point Power Kit, Optional 3-hp Motor**

	60 Hz				50 Hz
	208-3-60	230-3-60	460-3-60	575-3-60	380/415-3-50
<b>Base Evaporator Model Number</b>	MMD96E	MMD96E	MMD96E	MMD96E	MMD95E
<b>Base Condensing Unit Model Number</b>	MCD96A	MCD96A	MCD96A	MCD96A	MCD95A
<b>Cooling Only</b>					
FLA	521	514	254	192	26.0
WSA	57.3	56.6	27.9	21.1	N/A
OPD	70	70	35	25	N/A
<b>With Electric Reheat</b>					
FLA	79.9	76.5	38.0	29.2	40.4
WSA	92.0	88.0	43.7	33.6	N/A
OPD	100	100	50	35	N/A
<b>With SCR Reheat</b>					
FLA	93.7	89.1	44.2	N/A	47.7
WSA	109.3	103.7	51.4	N/A	N/A
OPD	110	110	60	N/A	N/A
<b>With Humidifier</b>					
FLA	63.9	62.0	30.7	23.5	32.1
WSA	69.1	67.2	33.2	25.4	N/A
OPD	80	80	40	30	N/A
<b>With Electric Reheat and Humidifier</b>					
FLA	79.9	76.5	38.0	29.2	40.4
WSA	92.0	88.0	43.7	33.6	N/A
OPD	100	100	50	35	N/A
<b>With SCR Reheat and Humidifier</b>					
FLA	105.5	99.7	49.5	N/A	53.8
WSA	121.1	114.3	56.7	N/A	N/A
OPD	125	125	60	N/A	N/A
FLA = Full Load Amps, WSA = Wire Size Amps, OPD = Maximum Overcurrent Protection Device					
For MMD96K/MMD95K electrical data, use appropriate MMD96E/MMD95E data (except SCR reheat is not available with free cooling option).					

## 5.5 Electrical Data for Water/Glycol Cooled Systems Using a Single-point Power Kit

Table 5.8 Water/Glycol Cooled Using Single-point Power Kit, Standard 2-hp Motor

	60Hz				50Hz
	208-3-60	230-3-60	460-3-60	575-3-60	380/415-3-60
Base Evaporator Model #	MMD96E	MMD96E	MMD96E	MMD96E	MMD95E
Base Condensing Unit Model #	MCD98W	MCD98W	MCD98W	MCD98W	MCD97W
<b>Cooling Only</b>					
FLA	39.0	39.0	19.5	14.7	20.1
WSA	44.2	44.2	22.0	16.6	N/A
OPD	60	60	30	20	N/A
<b>With Electric Reheat</b>					
FLA	66.8	64.1	32.1	24.7	34.5
WSA	78.9	75.6	37.8	29.1	N/A
OPD	90	80	40	30	N/A
<b>With SCR Reheat</b>					
FLA	80.6	76.7	38.3	N/A	41.8
WSA	96.2	91.3	45.5	N/A	N/A
OPD	100	100	50	N/A	N/A
<b>With Humidifier</b>					
FLA	50.8	49.6	24.8	19.0	26.2
WSA	56.0	54.8	27.3	20.9	N/A
OPD	70	70	35	25	N/A
<b>With Electric Reheat and Humidifier</b>					
FLA	66.8	64.1	32.1	24.7	34.5
WSA	78.9	75.6	37.8	29.1	N/A
OPD	90	80	40	30	N/A
<b>With SCR Reheat and Humidifier</b>					
FLA	92.4	87.3	43.6	N/A	47.9
WSA	108.0	101.9	50.8	N/A	N/A
OPD	110	110	60	N/A	N/A
FLA = Full Load Amps, WSA = Wire Size Amps, OPD = Maximum Overcurrent Protection Device For MMD96K/MMD95K electrical data, use appropriate MMD96E/MMD95E data (except SCR reheat is not available with free-cooling option).					

**Table 5.9 Water/Glycol Cooled Using Single-point Power Kit, Optional 3-hp Motor**

	60Hz				50Hz
	208-3-60	230-3-60	460-3-60	575-3-60	380/415-3-60
<b>Base Evaporator Model #</b>	MMD96E	MMD96E	MMD96E	MMD96E	MMD95E
<b>Base Condensing Unit Model #</b>	MCD98W	MCD98W	MCD98W	MCD98W	MCD97W
<b>Cooling Only</b>					
FLA	424	417	209	156	212
WSA	47.6	46.9	23.4	17.5	N/A
OPD	60	60	30	20	N/A
<b>With Electric Reheat</b>					
FLA	702	66.8	33.5	25.6	35.6
WSA	82.3	78.3	39.2	30.0	N/A
OPD	90	90	45	30	N/A
<b>With SCR Reheat</b>					
FLA	84.0	79.4	39.7	N/A	42.9
WSA	99.6	94.0	46.9	N/A	N/A
OPD	100	100	50	N/A	N/A
<b>With Humidifier</b>					
FLA	54.2	52.3	26.2	19.9	27.3
WSA	59.4	57.5	28.7	21.8	N/A
OPD	80	70	35	25	N/A
<b>With Electric Reheat and Humidifier</b>					
FLA	702	66.8	33.5	25.6	35.6
WSA	82.3	78.3	39.2	30.0	N/A
OPD	90	90	45	30	N/A
<b>With SCR Reheat and Humidifier</b>					
FLA	95.8	90.0	45.0	N/A	49.0
WSA	111.4	104.6	52.2	N/A	N/A
OPD	125	110	60	N/A	N/A
<small>FLA = Full Load Amps, WSA = Wire Size Amps, OPD = Maximum Overcurrent Protection Device                      For MMD96K/MMD95K electrical data, use appropriate MMD96E/MMD95E data (except SCR reheat is not available with free-cooling option).</small>					

## 5.6 Electrical Field Connections

Electrical service must conform to national and local electrical codes.

The electrical connections are described in the submittal documents included in the [Submittal Drawings](#) on page 49.

The following table lists the relevant documents by number and title.

**Table 5.10 Electrical Field Connection Drawings**

Document Number	Title
<b>Evaporator and Chilled-water Units</b>	
DPN000244	Electrical Connections
DPN000242	Single-point Power Kit for Close Coupled Units
DPN000243	Single-point Power Kit for Close Coupled Units, Detail view
DPN004853	Arrangement and Dimensions, Unit-mounted Vertiv™ Liebert® IS-UNITY-DP for BMS Communication
DPN004911	Arrangement and Dimensions, Wall-mounted Liebert® IS-UNITY-DP for BMS Communication
DPN004854	Electrical Connections, Liebert® IS-UNITY-DP for BMS Communication
<b>Split System Indoor Condensing Units</b>	
DPN004299	Electrical Connections, Air Cooled Units
DPN004301	Electrical Connections, Water/Glycol Cooled Units

This page intentionally left blank

## 6 Piping

The pipe connection locations, piping general arrangement and schematics are described in the submittal documents included in the [Submittal Drawings](#) on page 49.

The following tables list the relevant documents by number and title.

**Table 6.1 Piping General Arrangement Drawings**

Document Number	Title
DPN004416	General Arrangement, Air Cooled and Chilled Water
DPN000241	General Arrangement, Free Cooling and Hot Water Reheat Options
DPN004415	General Arrangement, Water/Glycol Cooled
DPN003822	Multiple Drycoolers and Cooling Units on Common Glycol Loop

**Table 6.2 Piping Connection Drawings**

Document Number	Title
<b>Evaporator and Chilled Water Units</b>	
DPN004305	Piping Connections
<b>Split-system Indoor Condensing Units</b>	
DPN004424	Piping Connections, Air-cooled units
DPN004425	Piping Connections, Water/Glycol Cooled Units
Condensate Pump Connection	
DPN000239	Field Installed Pump Connection

## 6.1 Refrigerant Piping Data

### 6.1.1 Refrigerant Charge Requirements

**Table 6.3 R-407C Refrigerant Unit Charge**

Model #		Charge R-407C, oz (kg)	
60 Hz	50 Hz	3-ton circuit	5-ton circuit
MMD96E	MMD95E	7 (0.20)	7 (0.20)
MMD96K	MMD95K	7 (0.20)	7 (0.20)
MCD96A	MCD95A	210 (6.0)	402 (11.4)
PFH096A	PFH095A	361 (10.2)	581 (16.5)
MCD98W	MCD97W	54 (1.5)	94 (2.7)

1. Use [Line Charges of R-407C Refrigerant Using Type-L Copper Tube](#) on the next page to determine the charge to be added for field-fabricated refrigerant lines.

**Table 6.4 Line Charges of R-407C Refrigerant Using Type-L Copper Tube**

Line Size, OD, in.	Liquid Line, lb/100 ft (kg/30 m)	Suction Line, lb/100 ft (kg/30 m)
3/8	3.6 (1.6)	—
1/2	6.7 (3.0)	0.2 (0.1)
5/8	10.8 (4.8)	0.3 (0.1)
3/4	16.1 (7.2)	0.4 (0.2)
7/8	22.3 (10.0)	0.5 (0.3)
1-1/8	38.0 (17.0)	0.9 (0.4)
1-3/8	57.9 (25.9)	1.4 (0.7)

Source: DPN003099 Rev. 1

### 6.1.2 Refrigerant Line Sizes and Equivalent Lengths

The following tables list information required to field install the refrigerant piping for the system.

The pipe connection sizes for your equipment are included in the appropriate submittal documents included in the [Submittal Drawings](#) on page 49.

**Table 6.5 Recommended refrigerant line sizes, O.D. cu by Equivalent Length**

Equivalent Length, ft (m)	3 Ton Circuit		5 Ton Circuit	
	Suction	Liquid	Suction	Liquid
50 (15)	7/8"	1/2"	1-1/8"	1/2"
75 (23)	7/8"	1/2"	1-1/8"	5/8"
100 (30)	1-1/8" <sup>2</sup>	1/2"	1-1/8"	5/8"
125 (38)	1-1/8" <sup>2</sup>	1/2"	1-3/8"	5/8"
150 (45)	1-1/8" <sup>2</sup>	1/2"	1-3/8"	5/8"

1. Suction line and liquid line sizing based on < 3 psi pressure drop in each and horizontal suction line refrigerant velocities >700 FPM (3.6 m/s).  
 2. Downsize vertical riser one trade size (1-1/8" to 7/8"), to maintain suction line velocity > 1000 FPM (5.1 m/s) for proper oil return.

Source: DPN000788 Rev. 13

**Table 6.6 Equivalent Lengths for Various Pipe Fittings, ft (m)**

Copper Pipe OD, in.	90 Degree Elbow Copper	90 Degree Elbow Cast	45 Degree Elbow	Tee	Gate Valve	Globe Valve	Angle Valve
1/2	0.8 (0.24)	1.3 (0.39)	0.4 (0.12)	2.5 (0.76)	0.26 (0.07)	7.0 (2.13)	4.0 (1.21)
5/8	0.9 (0.27)	1.4 (0.42)	0.5 (0.15)	2.5 (0.76)	0.28 (0.08)	9.5 (2.89)	5.0 (1.52)
3/4	1.0 (0.3)	1.5 (0.45)	0.6 (0.18)	2.5 (0.76)	0.3 (0.09)	12.0 (3.65)	6.5 (1.98)
7/8	1.45 (0.44)	1.8 (0.54)	0.8 (0.24)	3.6 (1.09)	0.36 (0.1)	17.2 (5.24)	9.5 (2.89)
1-1/8	1.85 (0.56)	2.2 (0.67)	1.0 (0.3)	4.6 (1.4)	0.48 (0.14)	22.5 (6.85)	12.0 (3.65)
1-3/8	2.4 (0.73)	2.9 (0.88)	1.3 (0.39)	6.4 (1.95)	0.65 (0.19)	32.0 (9.75)	16.0 (4.87)
1-5/8	2.9 (0.88)	3.5 (1.06)	1.6 (0.48)	7.2 (2.19)	0.72 (0.21)	36.0 (10.97)	19.5 (5.94)

Refrigerant trap = Four times equivalent length of pipe per this table

### 6.1.3 Piping when Condensing Unit is Above or Below Evaporator

Refer to [Pipe Length and Condensing Unit Elevation Relative to Evaporator](#) below, for the maximum vertical rise/fall between condensing unit and evaporator.

When installing remote condensing units above the evaporator, trap the suction gas line at the evaporator as shown in [Refrigerant Piping Diagram when Condenser is Above or Below Evaporator](#) on the next page. Traps recommended at the base of riser exceeding 5 ft (1.5 m) and every 20 ft (6 m) of vertical rise. This trap will retain refrigerant oil during the "Off" cycle. When the unit starts, oil in the trap is carried up the vertical riser and returns to the compressor.

When installing remote condensing units below the evaporator, trap the suction gas line with an inverted trap the height of the evaporator as shown [Refrigerant Piping Diagram when Condenser is Above or Below Evaporator](#) on the next page. This prevents refrigerant migration to the compressor during "Off" cycles. The maximum recommended vertical-level drop to condensing unit is 15 ft (4.6 m).

**Table 6.7 Pipe Length and Condensing Unit Elevation Relative to Evaporator**

Maximum Equivalent Pipe Length, ft (m)	Maximum Condensing Unit Level Above Evaporator, ft (m)	Maximum Condensing Unit Level Below Evaporator, ft (m)
150 (45)	50 (15)	15 (4.6)

Maximum recommended total equivalent pipe length is 150 ft (46 m). Suction and liquid lines may require additional specialty items when vertical lines exceed 20 ft. (6 m) and/or condensing unit installation is more than 15 ft. (4.6 m) below the evaporator. Contact Vertiv™ Technical Support for assistance.

Figure 6.1 Refrigerant Piping Diagram when Condenser is Above or Below Evaporator

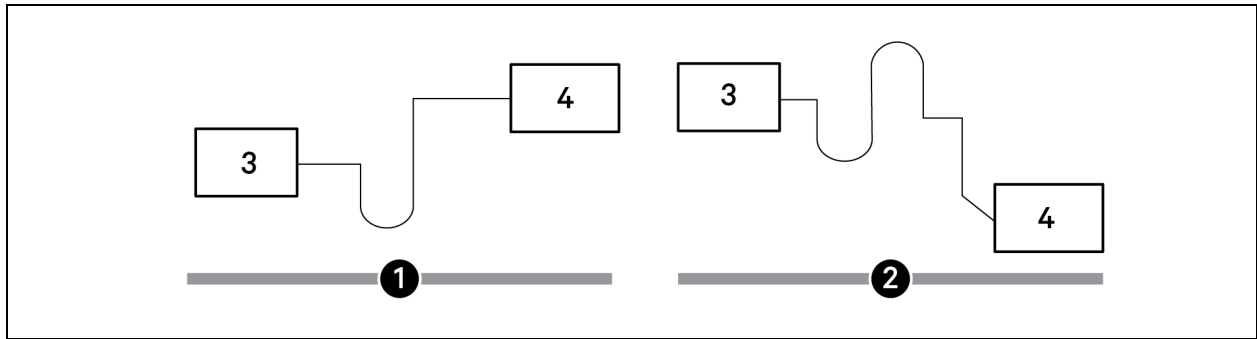

**NOTE:** Any horizontal pipe must be pitched down toward the condensing unit at a minimum rate of 1/2 in. (13 mm) per 10 ft (3 m) to assure oil return to compressor.

Item	Description
1	Condensing unit above evaporator
2	Condensing unit below evaporator
3	Evaporator
4	Condensing unit

## 6.2 Glycol Loop Piping

Contact Vertiv Application Engineering for assistance in choosing correct drycooler models. See DPN003822 included in the [Submittal Drawings](#) on page 49.

# Appendices

## Appendix A: Technical Support and Contacts

### A.1 Technical Support/Service in the United States

Vertiv Group Corporation

24x7 dispatch of technicians for all products.

1-800-543-2378

Liebert Thermal Management Products

1-800-543-2778

Liebert Channel Products

1-800-222-5877

Liebert AC and DC Power Products

1-800-543-2378

### A.2 Locations

#### United States

Vertiv Headquarters

505 N. Cleveland Ave.

Westerville, OH, 43082, USA

#### Europe

Via Leonardo Da Vinci 8 Zona Industriale Tognana

35028 Piove Di Sacco (PD) Italy

#### Asia

7/F, Dah Sing Financial Centre

3108 Gloucester Road, Wanchai

Hong Kong

This page intentionally left blank

## **Appendix B: Guide Specifications**

The following are the guide specifications for the Vertiv™ Liebert® Mini-Mate2.

# Vertiv™ Liebert® Mini-Mate2 8 - Ton GUIDE SPECIFICATIONS

## 1.0 GENERAL

### 1.1 Summary

These specifications describe requirements for a ceiling-mounted Thermal Management system. The system shall be designed to control temperature conditions in rooms containing electronic equipment, with good insulation and vapor barrier. The system is also available with an optional humidity control system.

The manufacturer shall design and furnish all equipment in the quantities and configurations shown on the project drawings.

### 1.2 Design Requirements

The Thermal Management system shall be a Liebert® Mini-Mate2 factory assembled unit. On direct expansion models, the refrigeration system shall be split, with the compressor located in a remote or close-coupled condensing unit.

The evaporator section shall be designed for above dropped-ceiling installation. Condensing units shall be designed for either outdoor or above-dropped-ceiling installation. Refer to Section 2.3 for condensing unit guide specifications.

The system shall have a net total cooling capacity of \_\_\_\_\_ BTU/hr (kW) and a net sensible cooling capacity of \_\_\_\_\_ BTU/hr (kW), based on entering air conditions of \_\_\_\_\_°F (°C) dry bulb and \_\_\_\_\_°F (°C) wet bulb. Net capacities shall include losses due to fan motor heat. The system cooling capacity shall be factory certified per ASHRAE 127-2007 testing.

The unit is to be supplied for operation on a \_\_\_\_\_ volt, \_\_\_\_\_ phase, \_\_\_\_\_ Hz power supply.

System shall be supplied with CSA Certification to the harmonized U.S. and Canadian product safety standard CSA C22.2 No 236/UL 1995 for "Heating and Cooling Equipment" and marked with the CSA c-us logo (60 Hz only).

The system model numbers shall be:

Evaporator \_\_\_\_\_

Condensing Unit \_\_\_\_\_

### 1.3 Submittals

Submittals shall be provided after the agreement of the proposal and shall include: Single-Line Diagrams; Dimensional, Electrical and Capacity data; Piping and Electrical Connection Drawings.

### 1.4 Quality Assurance

The specified system shall be factory-tested before shipment. Testing shall include, but shall not be limited to: Quality Control Checks, "HiPot" Test (two times rated voltage plus 1000 volts, per NRTL agency requirements) and Metering Calibration Tests. The system shall be designed and manufactured according to world class quality standards. The manufacturer shall be ISO 9001 certified.

## 1.5 Acceptable Alternatives

Acceptable alternatives shall be permitted with engineer's prior approval only. Contractor to submit a detailed summary form listing all variations to include size deviations, electrical load differences, functional and component changes, and savings to end user.

## 2.0 PRODUCT

### 2.1 Standard Features/All Systems

#### 2.1.1 Evaporator Cabinet Construction

The cabinet and chassis shall be constructed of heavy gauge galvanized steel and shall be serviceable from one side only. Mounting brackets shall be integral to the cabinet design. Internal cabinet insulation shall meet ASHRAE 62.1 requirements for Mold Growth, Humidity and Erosion, tested per UL 181 and ASTM 1338 standards.

#### 2.1.2 Air Distribution

The fan shall be the belt-drive, centrifugal type, double width, double inlet. The shaft shall be heavy-duty steel with self-aligning ball bearings with minimum life of 100,000 hours. The fan motor shall be 1750 rpm (1450 rpm @ 50hz) and mounted on an adjustable base. The drive package shall be equipped with an adjustable motor pulley. The fan/motor assembly shall be mounted on vibration isolators.

The evaporator system shall be capable of delivering \_\_\_\_CFM (CMH) at \_\_\_ inches (mm) of external static pressure.

The fan motor shall be \_\_\_\_ HP (W).

System shall be suitable for ducted supply and return air distribution. Refer to 2.5.2 Air Filter Box/Duct Flange.

#### 2.1.3 Microprocessor Control

The control system shall be microprocessor-based, factory-wired into the system cabinet and tested prior to shipment. The wall-mounted controller shall include a 2-line by 16-character liquid crystal display (LCD) providing continuous display of operating status and alarm condition which is wired into the control board using 4-conductor field-supplied wire. A 7-key membrane keypad for setpoint/program control and unit On/Off shall be located below the display. The control shall be capable of displaying values in °F or °C. Wall-mounted controller shall be password protected to prevent unauthorized set point adjustments.

The controller shall provide three stages of cooling for direct expansion units by cycling the 3-ton compressor, 5-ton compressor and then both compressors. The controller shall determine the average cooling requirements, updated every hour, to determine the lead compressor to minimize compressor cycling or the lead compressor shall be user selectable from the wall controller.

For chilled water units, the controller shall adjust the modulating chilled water valve.

Temperature and humidity sensors shall be located in the wall controller, which shall be capable of being located up to 300 ft (91.4m) from the evaporator unit when using a remote temperature/humidity sensor in the conditioned space.

#### Monitoring

The LCD shall provide an On/Off indication, operating mode indication (cooling, heating, humidifying, dehumidifying) and current day, time, temperature, and humidity (if applicable) indication. The monitoring system shall be capable of relaying unit operating parameters and alarms to the Vertiv™ Liebert® IS-UNITY-DP monitoring system.

### Control Setpoint Parameters

- Temp. Setpoint 65-85°F (18-29°C)
- Temp. Sensitivity 1-9.9 °F (1-5°C)
- Humidity Setpoint 20-80% RH
- Humidity Sensitivity 1-30% RH

### Unit Controls

#### 1. Compressor Short-Cycle Control

The control system shall prevent compressor short-cycling by a 3-minute timer from compressor stop to the next start.

#### 2. Common Alarm and Remote On/Off

A common alarm relay shall provide a contact closure to a remote alarm device. Two (2) terminals shall also be provided for remote On/Off control. Individual alarms shall be “enabled” or “disabled” from reporting to the common alarm.

#### 3. Setback Control

The control shall be user-configurable to use a manual setpoint control or a programmable, time-based setback control. The setback control will be based on a 5 day/2 day programmed weekly schedule with capability of accepting two events per program day.

#### 4. Temperature Calibration

The control shall include the capabilities to calibrate the temperature and humidity sensors and adjust the sensor response delay time from 10 to 90 seconds. The control shall be capable of displaying temperature values in °F or °C.

#### 5. System Auto Restart

For startup after power failure, the system shall provide automatic restart with a programmable (up to 9.9 minutes in 6-second increments) time delay. Programming can be performed either at the wall-mounted controller or from the central, site-monitoring system.

### 2.1.4 Electrical Switches and Sensors

#### 1. Disconnect Switch, Non-Locking

The non-automatic, non-locking, molded case circuit interrupter shall be factory mounted in the high-voltage section of the electrical panel. The switch handle shall be accessible from the unit front and mounted on:

- \_\_\_\_\_ the evaporator/chilled water unit
- \_\_\_\_\_ the indoor air-cooled centrifugal condensing unit
- \_\_\_\_\_ the water/glycol-cooled condensing unit.

#### 2. High-Temperature Sensor

The high-temperature sensor shall immediately shut down the system when high temperatures (125°F, 51.7°C) are detected. The high-temperature sensor shall be mounted with the sensing element in the return air.

#### 3. Filter Clog Switch

The filter clog switch senses pressure drop across the filters and shall annunciate the wall controller upon exceeding the adjustable setpoint.

## 2.1.5 Alarms

### 1. Unit Alarm

The control system shall monitor unit operation and activate an audible and visual alarm in the event of the following factory preset alarm conditions:

- High Temperature
- Low Temperature
- High Humidity
- Low Humidity
- High Water Alarm - Lockout Unit Operation
- High Head Pressure #1 and #2
- Loss of Power
- Compressor Short Cycle #1 and #2
- Humidifier Problem
- Filter Clog

### Custom Alarms (3x)

- Smoke Detected
- Standby Unit On
- Water Flow Loss
- Standby GC Pump
- Custom 1
- Custom 2
- Custom 3

User-customized text can be entered for the three (3) custom alarms.

### 2. Alarm Controls

Each alarm (unit and custom) shall be individually enabled or disabled (except for high head pressure and high water in condensate pan) and can be programmed for a time delay of 0 to 255 seconds of continuous alarm condition to be recognized as an alarm. Each alarm can also be enabled or disabled to activate the common alarm (except high head pressure and high water in condensate pan).

### 3. Audible Alarm

The audible alarm shall annunciate at the LCD wall box any alarm that is enabled by the operator.

### 4. Common Alarm

A programmable common alarm shall be provided to interface user selected alarms with a remote alarm device. Alarms shall be enabled or disabled from reporting to the common alarm.

### 5. Remote Monitoring

All alarms shall be communicated to the Liebert remote monitoring system with the following information: date and time of occurrence, unit number and present temperature and humidity.

## 2.2 Direct Expansion System Evaporator Components

### 2.2.1 Direct Expansion Coil

The direct expansion units shall have two (2) independent refrigeration circuits; a nominal 3-ton circuit and a nominal 5-ton circuit to provide three levels of cooling.

The evaporator coil shall have two circuits, minimum 7.6 sq. ft. (0.71 sq. m) face area, four rows deep, constructed of copper tubes and aluminum fins, and have a maximum face velocity of \_\_\_ ft. per minute (m/s) at \_\_\_ CFM (CMH). Externally equalized thermostatic expansion valves shall control refrigerant flow. A filter drier shall be provided for each circuit. The refrigerant piping shall be spun-closed and filled with a nitrogen holding charge. Field relief of the Schrader valves shall indicate a leak-free system. Evaporator and condensing unit shall be field piped using copper lines, brazed, evacuated and field charged with R-407C refrigerant.

The coil assembly shall be mounted in a condensate drain pan, with an internally trapped drain line. The evaporator drain pan shall include a factory-installed float switch to shut down the evaporator upon high water condition.

## 2.3 Chilled Water System Components

### 2.3.1 Chilled Water Control Valve

A (2-way) (3-way) modulating, non-spring return valve shall be controlled by the microprocessor to position the valve in response to room conditions. Water-side design pressure shall be 400 psig (2757 kPa) static pressure, with a maximum close-off pressure of \_\_\_\_ psi (kPa).

### 2.3.2 Chilled Water Coil

The cooling coil shall have a minimum 7.6 sq. ft. (0.71 sq. m) face area, four rows deep, constructed of copper tubes and aluminum fins, and have a maximum face velocity of \_\_\_\_ ft. per minute (m/s) at \_\_\_\_ CFM (CMH). The coil shall be supplied with 45°F (7.2°C) entering water temperature. The coil shall be supplied with \_\_\_\_\_ GPM (l/s) of chilled water and the pressure drop shall not exceed \_\_\_\_\_ PSI (kPa). The coil assembly shall be mounted in a condensate drain pan with internally trapped drain line. The evaporator drain pan shall include a factory-installed float switch to shutdown the unit upon high water condition.

## 2.4 Indoor Air-Cooled Centrifugal Fan Condensing Unit

Condensing unit components shall include a two (2) circuit condenser coil, a 3-ton scroll compressor, a 5-ton scroll compressor, and each shall contain a high-pressure switch, Vertiv™ Liebert® Lee-Temp refrigerant receiver, head pressure control valve, hot gas bypass system and liquid line solenoid valve. A non-automatic, non-locking, molded case disconnect switch shall be factory mounted in the high voltage section of the electrical panel. The switch handle shall be accessible from the unit front. The cabinet and chassis shall be constructed of heavy gauge galvanized steel and shall be serviceable from one side. Mounting brackets shall be integral to the cabinet design and be designed for ceiling mounting.

The hot gas bypass circuit shall be provided to reduce compressor cycling and improve operation under low load conditions. The two hot gas bypass systems shall be completely contained in the condensing unit. Field installed third refrigerant lines shall not be acceptable. Hot gas bypass shall be automatically deactivated upon a call for dehumidification.

High pressure switches shall protect the unit from abnormal refrigerant pressure conditions and shall deactivate the compressor affected and annunciate an alarm at the wall controller. The blower shall continue to circulate air. The wall controller shall be used to manually restart the compressor function after the automatic pressure switch resets. Three high head pressure alarms in a rolling 12-hour period shall lock out the manual restart feature until power is cycled to the evaporator unit.

A pressure balancing valve shall be factory installed on each circuit to reduce the chance of high pressure cut-out due to excessive refrigerant migration to the receiver due to changing outdoor temperatures during off-cycles.

The refrigerant piping shall be spun-closed and filled with a nitrogen holding charge. Field relief of the Schrader valves shall indicate a leak-free system. Evaporator and condensing unit shall be field piped using copper lines, brazed, evacuated and field charged with R-407C refrigerant. Condensing unit shall be designed for 95°F (35°C) ambient and be capable of operation to -30°F (-34.4°C) inlet air temperature. The condensing unit can be coupled directly to the evaporator or can be mounted remote to the evaporator.

The condensing unit coil shall have a minimum 9.2 sq. ft. (0.85 sq. m) face area, four rows deep, constructed of copper tubes and aluminum fins. The condenser fan shall be centrifugal type, double inlet, heavy-duty steel shaft, with self-aligning bearings. The fan motor shall operate at 1750 rpm (1450 rpm @ 50 Hz), shall be equipped with adjustable motor pulley, and shall be mounted on an adjustable base. The fan and motor assembly shall be mounted on vibration isolators. The fan motor assembly shall be belt-drive.

The condenser fan shall be designed for \_\_\_\_CFM (CMH) at \_\_\_\_" (mm) external static pressure.

## 2.5 Outdoor Air-Cooled Prop Fan Condensing Unit

The condensing unit shall be designed for outdoor use with either roof or ground level mounting. The condensing unit is constructed of galvanized and galvaneal painted steel for corrosion resistance. Removable exterior panels shall allow access to the electric panel or refrigeration components for service or maintenance. Both inlet and outlet air grilles shall be heavy duty steel with a durable polyester coating.

Condensing unit components shall include two (2) independent refrigeration circuits, with one based on a 3-ton compressor and the other based on a 5-ton compressor. Each circuit shall contain a scroll compressor, condenser coil, high-pressure switch, Vertiv™ Liebert® Lee-Temp insulated refrigerant receiver with internal heater, head pressure control valve, hot gas bypass system and liquid line solenoid valve.

The hot gas bypass circuit shall be provided to reduce compressor cycling and improve operation under low load conditions. The two (2) hot gas bypass systems shall be completely contained in the condensing unit. Field installed third refrigerant lines shall not be acceptable. Hot gas bypass shall be automatically deactivated upon a call for dehumidification.

High pressure switches shall protect the unit from abnormal refrigerant pressure conditions and shall deactivate the compressor affected and annunciate an alarm at the wall controller. The blower shall continue to circulate air. The wall controller shall be used to manually restart the compressor function after the automatic pressure switch resets. Three high head pressure alarms in a rolling 12-hour period shall lock out the manual restart feature until power is cycled to the evaporator unit.

A pressure balancing valve shall be factory installed on each circuit to reduce the chance of high pressure cut-out due to excessive refrigerant migration to the receiver due to changing outdoor temperatures during off-cycles.

The condenser coils shall be constructed of copper tubes and aluminum fins. A common direct-drive propeller fan shall provide the heat rejection airflow. The condensing unit refrigerant piping shall be spun-closed and filled with a nitrogen holding charge. Field relief of the Schrader valves shall indicate a leak-free system. Evaporator and condensing unit shall be field piped using copper lines, brazed, evacuated and field charged with R-407C refrigerant.

Condensing unit shall be designed for 95°F (35°C) ambient and be capable of operation to -30°F (-34.4°C).

(Option) The coils shall be epoxy-coated for extended coil life in corrosive environments, such as coastal areas. Factory-applied E-coat using immersion and baking process shall provide a flexible epoxy-coating to all coil surfaces. Coil color shall be black and shall be protected from solar UV ray degradation with a factory-applied UV topcoat.

## 2.6 Indoor Water/Glycol-Cooled Condensing Unit

The water/glycol condensing unit shall include two (2) independent refrigeration circuits, with one based on a 3-ton compressor and the other based on a 5-ton compressor. Each circuit shall contain a scroll compressor, coaxial condenser, water-regulating valve, high head pressure switch, hot gas bypass system and liquid line solenoid valve. A non-automatic, non-locking, molded case disconnect switch shall be factory mounted in the high voltage section of the electrical panel. The switch handle shall be accessible from the unit front. The cabinet and chassis shall be constructed of heavy gauge galvanized steel and shall be serviceable from one side. Mounting brackets shall be integral to the cabinet design and be designed for ceiling mounting.

The hot gas bypass circuit shall be provided to reduce compressor cycling and improve operation under low load conditions. The two (2) hot gas bypass systems shall be completely contained in the condensing unit. Field installed third refrigerant lines shall not be acceptable. Hot gas bypass shall be automatically deactivated upon a call for dehumidification.

High pressure switches shall protect the unit from abnormal refrigerant pressure conditions and shall deactivate the compressor affected and annunciate an alarm at the wall controller. The blower shall continue to circulate air. The wall controller shall be used to manually restart the compressor function after the automatic pressure switch resets. Three high head pressure alarms in a rolling 12-hour period shall lock out the manual restart feature until power is cycled to the evaporator unit.

The condensing unit refrigerant piping shall be spun-closed and filled with a nitrogen holding charge. Field relief of the Schrader valves shall indicate a leak-free system. Evaporator and condensing unit shall be field piped using copper lines, brazed, evacuated and field charged with R-407C refrigerant.

The water/glycol condensing unit shall be equipped with two coaxial condenser coils piped to common supply and return headers and shall have a total system pressure drop of \_\_\_\_\_ ft. of water (kPa) and a flow rate of \_\_\_\_\_ GPM (l/s) with \_\_\_\_\_ °F (°C) entering water/glycol temperature.

Each condenser coil shall be pre-piped with a [(2-way) (3-way)] regulating valve which is head-pressure actuated.

The condenser water/glycol circuit shall be designed for a static operating pressure of [(150 PSI (1034kPa)) (350 PSI (2413 kPa))].

## 2.7 Factory-Installed Options

### 2.7.1 Steam Generating Humidifier

The Thermal Management system shall be equipped with a steam generating humidifier that is controlled by the microprocessor control system. It shall be complete with disposable canister, all supply and drain valves, 1" (25.4 mm) air gap on fill line, inlet strainer, steam distributor and electronic controls. The need to change canister shall be annunciated on the microprocessor wall box control panel. The humidifier shall have a capacity of 4.5 lb/hr (10 kg/h). An LED light on the humidifier assembly shall indicate cylinder full, overcurrent detection, fill system fault and end of cylinder life conditions. The canister flush water shall not drain into the coil drain pan, due to risk of aggressive corrosion of the evaporator coil. The humidifier wand shall be mounted over the coil drain pan.

### 2.7.2 Electric Reheat

The electric reheat shall be low-watt density, 304/304 stainless steel, finned-tubular and shall be capable of maintaining room dry bulb conditions when the system is calling for dehumidification. The reheat section shall include an agency-approved safety switch to protect the system from overheating. A ground current detector shall be factory installed to shut-down the entire unit if a ground fault in the reheat system is detected.

The capacity of the reheat coils shall be \_\_\_\_\_ BTU/HR (kW), with unit input voltage of \_\_\_\_\_ V, controlled in two stages.

### 2.7.3 Hot Water Reheat

The hot water reheat coil shall have copper tubes and aluminum fins with a capacity of \_\_\_\_\_ BTU/HR (kW) when supplied with \_\_\_\_\_°F (°C) entering water temperature at \_\_\_\_\_ GPM (l/s) flow rate. Maximum pressure drop shall be \_\_\_\_\_ PSI (kPa). The control system shall be factory-prepped with a 2-way solenoid valve and cleanable Y-strainer. The hot water reheat coil shall only be available on chilled water units.

### 2.7.4 SCR Electric Reheat

The electric reheat shall be low-watt density, 304/304 stainless steel, finned-tubular and shall be capable of maintaining room dry bulb conditions when the system is calling for dehumidification. The reheat section shall include an agency-approved safety switch to protect the system from overheating. A ground current detector shall be factory installed to shut-down the entire unit if a ground fault in the reheat system is detected.

The SCR (Silicon Controlled Rectifier) controller shall proportionally control the reheat elements to maintain the selected room temperature. The rapid cycling made possible by the SCR controller provides precise temperature control, and the more constant element temperature improves heater life. The unit microprocessor control shall operate the SCR controller, while cooling is locked on. The capacity of the reheat coils shall be \_\_\_\_\_ BTU/HR (kW), unit input voltage of \_\_\_\_\_ V. Not available on chilled water or free-cooling units.

### 2.7.5 Smoke Sensor

The smoke sensor shall immediately shut down the Thermal Management system and activate the alarm system when activated. The sensing element shall be located in the return air compartment. This smoke sensor shall not function or replace any room smoke detection system that may be required by local or national codes.

### 2.7.6 Remote Monitoring and Control – IS-UNITY-DP And BMS

The Vertiv™ Liebert® IS-UNITY-DP BMS Monitoring Solution shall provide SNMP v1/v2c/v3, BACnet IP, BACnet MSTP, Modbus TCP/IP, and Modbus RTU monitoring capability to the Vertiv™ Liebert® Mini-Mate2 system. Card shall employ Ethernet and RS-485 networks to monitor and manage a wide range of operating parameters pertaining to the cooling system. The Unity card shall provide access to the Liebert® Mini-Mate2 remotely via a web interface and shall support Vertiv™ Liebert® Nform connectivity. The IS-UNITY-DP card shall be factory mounted inside an enclosure on the outside of the Liebert® Mini-Mate2 unit and shall be factory wired for power and unit communications. Ethernet cable providing network access to the world-wide web or to a BMS shall be field wired.

## 2.7.7 Free-Cooling/Dual Cooling Coil

**Note: The free cooling option is no longer available.**

A secondary free-cooling coil shall be integral to the evaporator cabinet and shall be constructed of copper tubes and aluminum fins. The coil shall be rated at \_\_\_\_\_ BTU/HR (kW) sensible cooling capacity with a 45°F (22°C), \_\_\_% glycol solution. The coil shall require \_\_\_\_\_ GPM (l/s) and the total unit pressure drop shall not exceed \_\_\_\_\_ feet of water (kPa) when in the free cooling mode. Free cooling shall be activated when the inlet coolant temperature is low enough to provide cooling and shall include factory piped three-way valves.

Coil shall be designed for closed-loop applications using properly treated and circulated fluid. An optional CuNi coil or a field-supplied heat exchanger system shall be required to prevent premature corrosion if applied to open water tower loop. Not available with SCR reheat.

## 2.8 Ship - Loose Accessories

### 2.8.1 Remote Sensors

The unit shall be supplied with remote temperature and humidity sensors. The sensors shall be connected to the unit by a \_\_\_\_\_ ft. \_\_\_\_\_ (m) shielded cable.

### 2.8.2 Air Filter Box/Duct Flange

The evaporator section shall be supplied with an air filter box for use with ducted installations. Two (2) filters shall be included 4" x 20" x 25" (102 mm x 508mm x 635mm) each, deep-pleated type, with a MERV 8 rating, based on ASHRAE 52.2-2007. A duct flange shall be supplied for use on the supply air opening of the unit.

### 2.8.3 Condensate Pump

The condensate pump shall have the capacity of \_\_\_\_\_ GPH (\_\_\_ l/h) at \_\_\_ ft. head (\_\_\_ kPa). It shall be complete with integral float switch, discharge check valve, pump, motor assembly and reservoir. A secondary float switch on the condensate pump shall tie into the unit to provide an alarm on the wall-mounted controller and shut down the unit upon high water in the basin of the pump. Condensate pump shall be powered from the Liebert® Mini-Mate2. A separate electrical feed is not acceptable.

### 2.8.4 Condensate Pump Bracket

A condensate pump bracket shall be provided to mount condensate pump to the end of the unit and allow easy alignment and installation of the condensate pump.

### 2.8.5 Single Point Power Kit

A Single Point Power Kit shall be provided for a close-coupled system to allow a single electrical feed to supply power to both the evaporator and indoor close-coupled (attached) condensing unit.

#### **Remote Monitoring and Control – IS-Unity-DP and BMS – Field-installed Unit-mount Kit**

The Vertiv™ Liebert® IS-UNITY-DP BMS Monitoring Solution shall provide SNMP v1/v2c/v3, BACnet IP, BACnet MSTP, Modbus TCP/IP, and Modbus RTU monitoring capability to the Vertiv™ Liebert® Mini-Mate2 system. Card shall employ Ethernet and RS-485 networks to monitor and manage a wide range of operating parameters pertaining to the cooling system. The Unity card shall provide access to the Liebert® Mini-Mate2 remotely via a web interface and shall support Vertiv™ Liebert® Nform connectivity. The unit-mount external enclosure kit for field-installation shall include the IS-UNITY-DP card, power/communication interface card, galvanized steel enclosure, power and communication wire harnesses and full instructions. Field-supplied wiring for communication from the Liebert® Mini-Mate2 to other systems shall be required to access features.

### 2.8.6 Remote Monitoring and Control – IS-Unity-DP and BMS – Field-installed Wall-mount Kit

The Liebert® IS-UNITY-DP BMS Monitoring Solution shall provide SNMP v1/v2c/v3, BACnet IP, BACnet MSTP, Modbus TCP/IP, and Modbus RTU monitoring capability to the Liebert® Mini-Mate2 system. Card shall employ Ethernet and RS-485 networks to monitor and manage a wide range of operating parameters pertaining to the cooling system. The Unity card shall provide access to the Liebert® Mini-Mate2 remotely via a web interface and shall support Liebert® Nform connectivity. The wall-mount kit for field-installation shall include the IS-UNITY-DP card, power/communication interface card, painted enclosure, 120V wall outlet transformer with 6ft (2m) low voltage power wire, and full instructions. Power shall be supplied from unit using field-supplied wiring or from single phase power (120 V) source using included transformer. Field-supplied wiring for communication to the Liebert® Mini-Mate2 and to other systems shall be required to access features.

### 2.8.7 Drycooler

The Liebert drycooler shall be a low-profile, direct-drive propeller fan-type air-cooled unit. The drycooler shall be constructed with an aluminum cabinet and a copper-tube aluminum fin coil, and multiple direct drive fans. All electrical connections and controls shall be enclosed in an integral electric control panel. Weatherproof section of the drycooler the unit is quiet and corrosion resistant.

The drycooler shall be designed for \_\_\_\_ °F (°C) ambient.

### 2.8.8 Glycol Pump Package

The system shall include a centrifugal pump mounted in a weatherproof and vented enclosure. The pump shall be rated for \_\_\_\_ gpm (l/s) at \_\_\_\_ ft. (kPa) of head, and operate on \_\_\_\_ volt, \_\_\_\_ phase, \_\_\_\_\_ Hz.

## 3.0 EXECUTION

### 3.1 Installation of Air Conditioning Unit

#### 3.1.1 General

Install air conditioning unit in accordance with manufacturer's installation instructions. Install unit plumb and level, firmly anchored in location indicated, and maintain manufacturer's recommended clearances.

#### 3.1.2 Electrical Wiring

Install and connect electrical devices furnished by manufacturer but not specified to be factory mounted. Furnish copy of manufacturer's electrical connection diagram submittal to electrical contractor. Install and wire per local and national codes.

#### 3.1.3 Piping Connections

Install and connect devices furnished by manufacturer but not specified to be factory mounted. Furnish copy of manufacturer's piping connection diagram submittal to piping contractor.

#### 3.1.4 Supply and Drain Water Piping

Connect water supply and drains to air conditioning unit. Unit drain shall be trapped internally and shall not be trapped externally.

#### 3.1.5 Field-Supplied Pan

A field-supplied pan with drain shall be installed beneath cooling units and water/glycol condensing units.

### 3.2 Field Quality Control

Startup air conditioning unit in accordance with manufacturer's startup instructions. Test controls and demonstrate compliance with requirements.

This page intentionally left blank

## Appendix C: Submittal Drawings

[Submittal Drawings Contents](#) below, groups the drawings by topic/application.

**Table C.1 Submittal Drawings Contents**

Document Number	Title
<b>Planning Dimensions - Split System Evaporators/Chilled Water Units</b>	
DPN000240	Evaporator/Chilled Water and Option Dimensions
<b>Planning Dimensions - Indoor Condensing Units</b>	
DPN004424	Cabinet Dimensions, Air Cooled Units
DPN004425	Cabinet Dimensions, Water/Glycol Cooled Units
<b>Planning Dimensions - Outdoor Condensing Units</b>	
DPN004419	Cabinet Dimensions, Prop Fan Condensing Unit with Top Air Discharge
<b>Piping General Arrangement</b>	
DPN004416	General Arrangement, Air Cooled and Chilled Water
DPN000241	General Arrangement, Free Cooling and Hot Water Reheat Options
DPN004415	General Arrangement, Water/Glycol Cooled
DPN003822	Multiple Drycoolers and Cooling Units on Common Glycol Loop
<b>Piping Connections - Evaporator and Chilled Water Units</b>	
DPN004305	Piping Connections
<b>Condensate Pump Connection</b>	
DPN000239	Field Installed Pump Connection
<b>Piping Connections - Split-system Indoor Condensing Units</b>	
DPN004424	Piping Connections, Air Cooled Units
DPN004425	Piping Connections, Water/Glycol Cooled Units
<b>Electrical Connections - Evaporator and Chilled Water Units</b>	
DPN000244	Electrical Connections
DPN000242	Single-point Power Kit for Close Coupled Units
DPN000243	Single-point Power Kit for Close Coupled Units, Detail view
DPN004853	Arrangement and Dimensions, Unit Mounted Vertiv™ Liebert® IS-UNITY-DP for BMS Communication
DPN004911	Arrangement and Dimensions, Wall Mounted Liebert® IS-UNITY-DP for BMS Communication
DPN004854	Electrical Connections, Liebert® IS-UNITY-DP for BMS Communication
<b>Electrical Connections - Split-system Indoor Condensing Units</b>	
DPN004299	Electrical Connections, Air Cooled
DPN004301	Electrical Connections, Water/Glycol Cooled



**VERTIV**

# LIEBERT® MINI-MATE2

## CABINET DIMENSIONAL DATA 8 TON EVAPORATOR OR CHILLED WATER UNIT

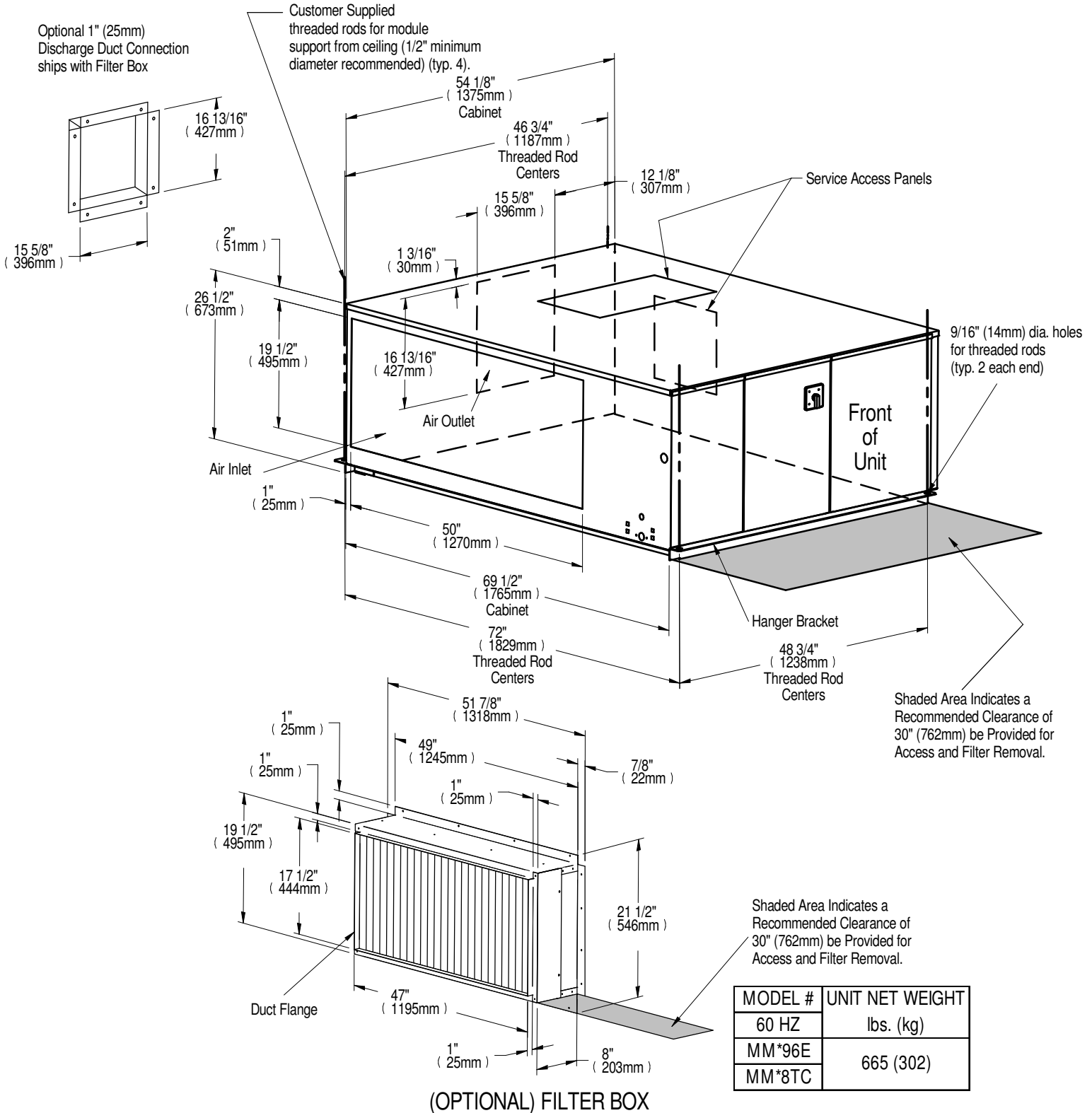

MODEL #	UNIT NET WEIGHT
60 HZ	lbs. (kg)
MM*96E	665 (302)
MM*8TC	

## CABINET DIMENSIONAL DATA & PRIMARY CONNECTION LOCATIONS 8 TON AIR COOLED INDOOR CONDENSING MODULES

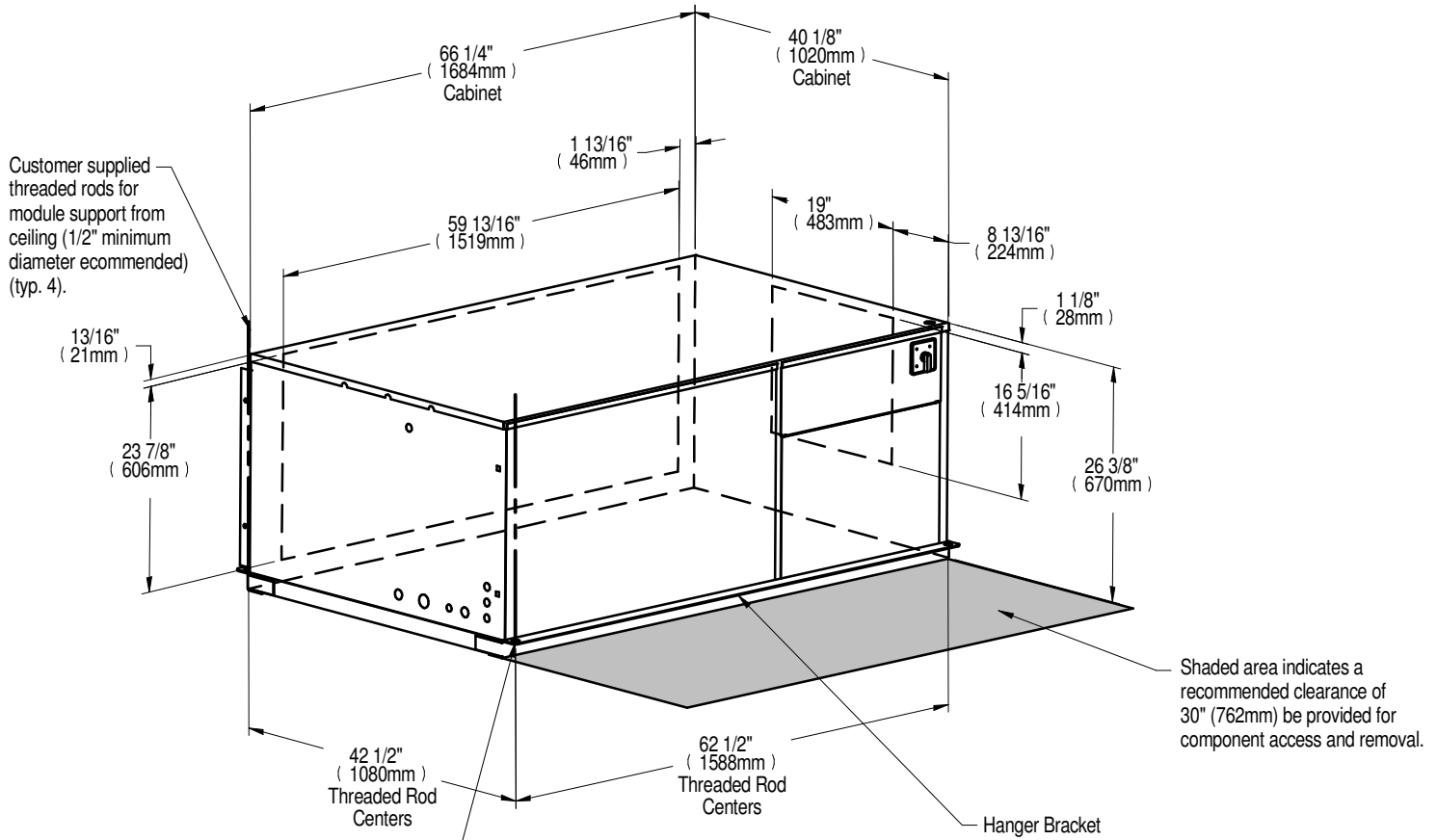

NOTE: Unit is spaced evenly in reference to threaded rod centers.

MODEL		UNIT NET WEIGHT lbs. (kg)
60 HZ	50 HZ	
MC*96A	MC*95A	530 (240)

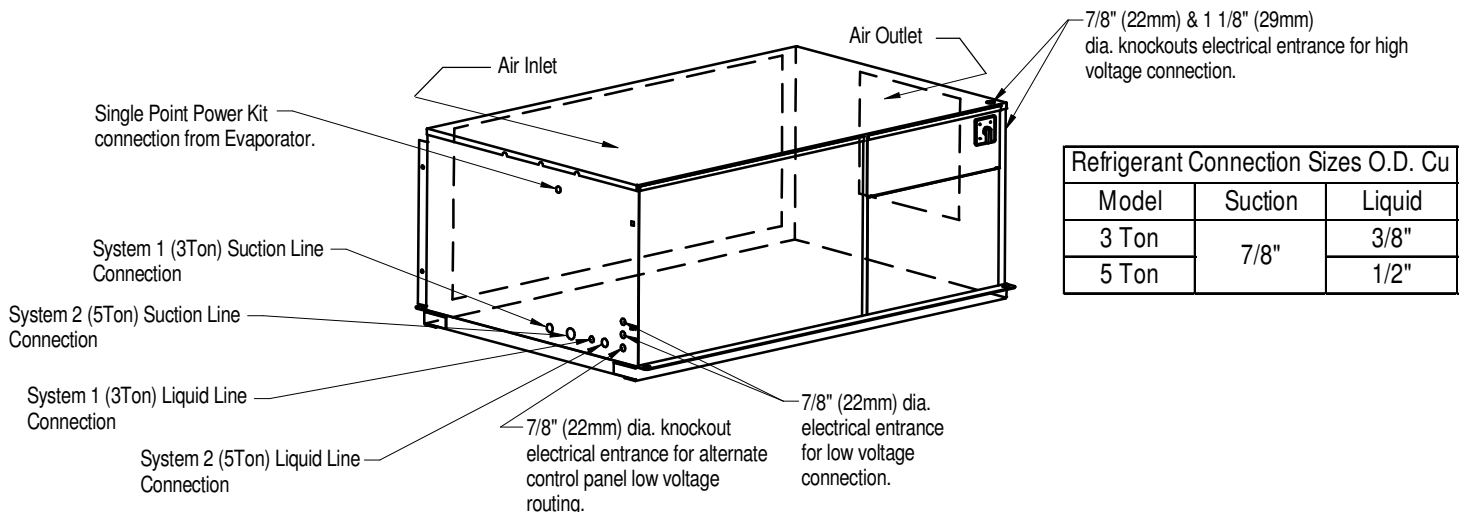

Model	Suction	Liquid
3 Ton	7/8"	3/8"
5 Ton		1/2"



# LIEBERT® MINI-MATE2

## CABINET DIMENSIONAL DATA & PRIMARY CONNECTION LOCATIONS 8 TON WATER/GLYCOL COOLED INDOOR CONDENSING MODULE

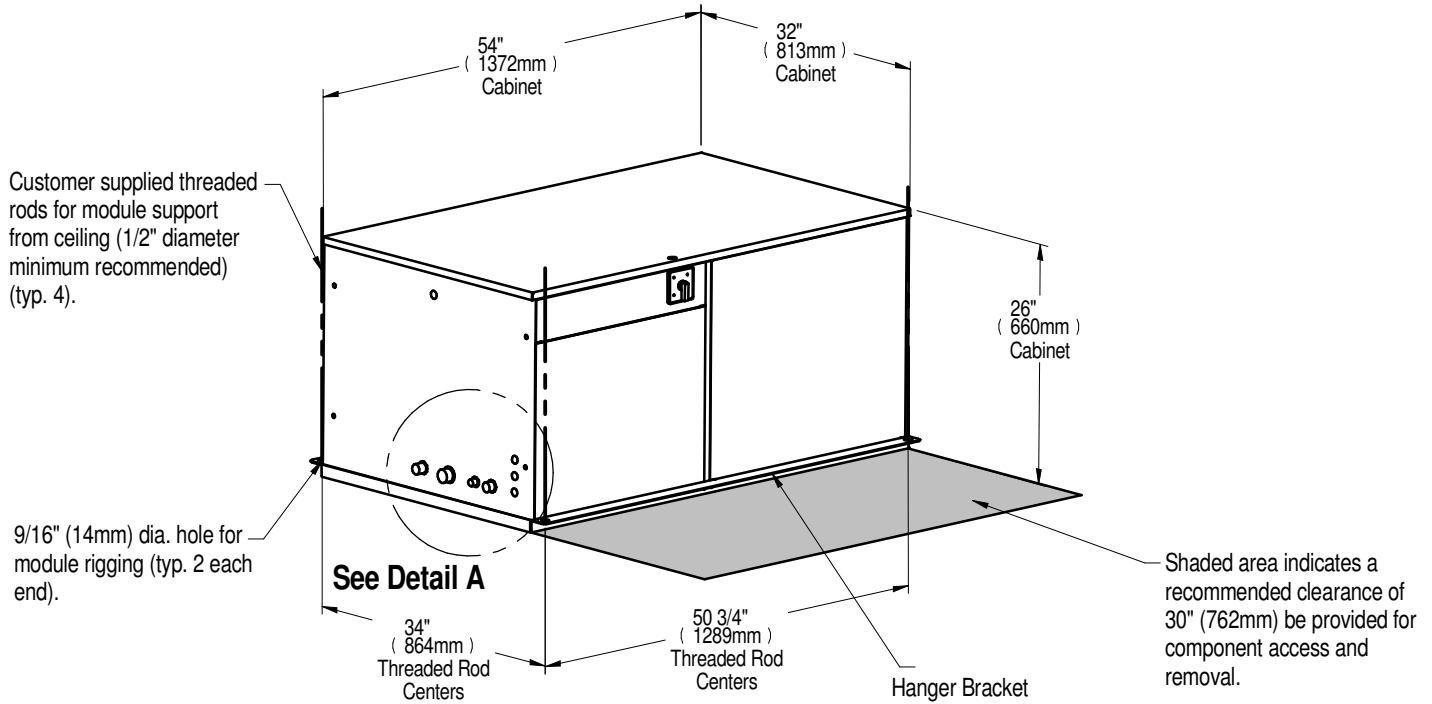

NOTE: Unit is evenly spaced in reference to threaded rod centers.

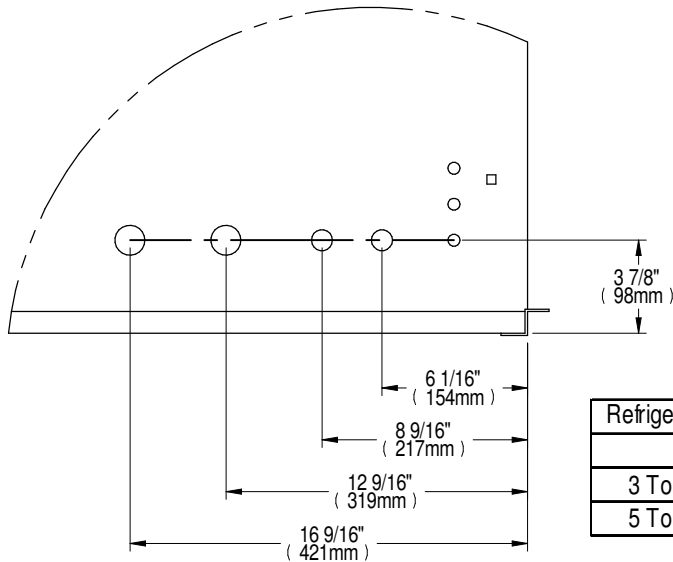

Detail "A"

Refrigerant Connection Sizes O.D. Cu		
	Suction	Liquid
3 Ton	7/8"	3/8"
5 Ton		1/2"

MODEL #		UNIT NET WEIGHT
60 HZ	50 HZ	lbs. (kg)
MC*98W	MC*97W	470 (213)



# LIEBERT® MINI-MATE2

## CABINET DIMENSIONAL DATA & PRIMARY CONNECTION LOCATIONS 8 TON WATER/GLYCOL COOLED INDOOR CONDENSING MODULE

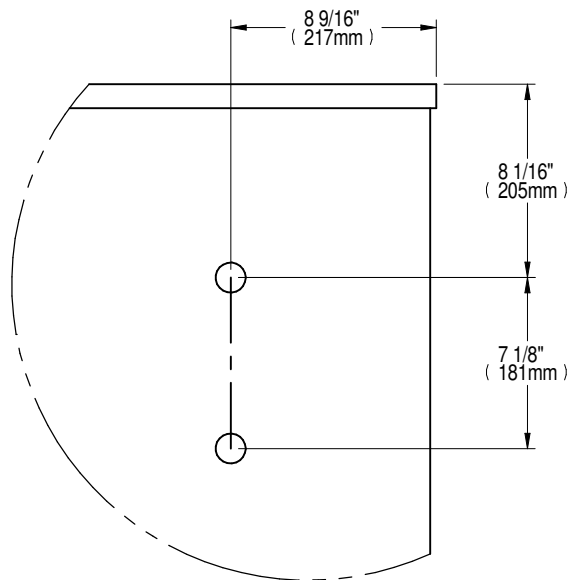
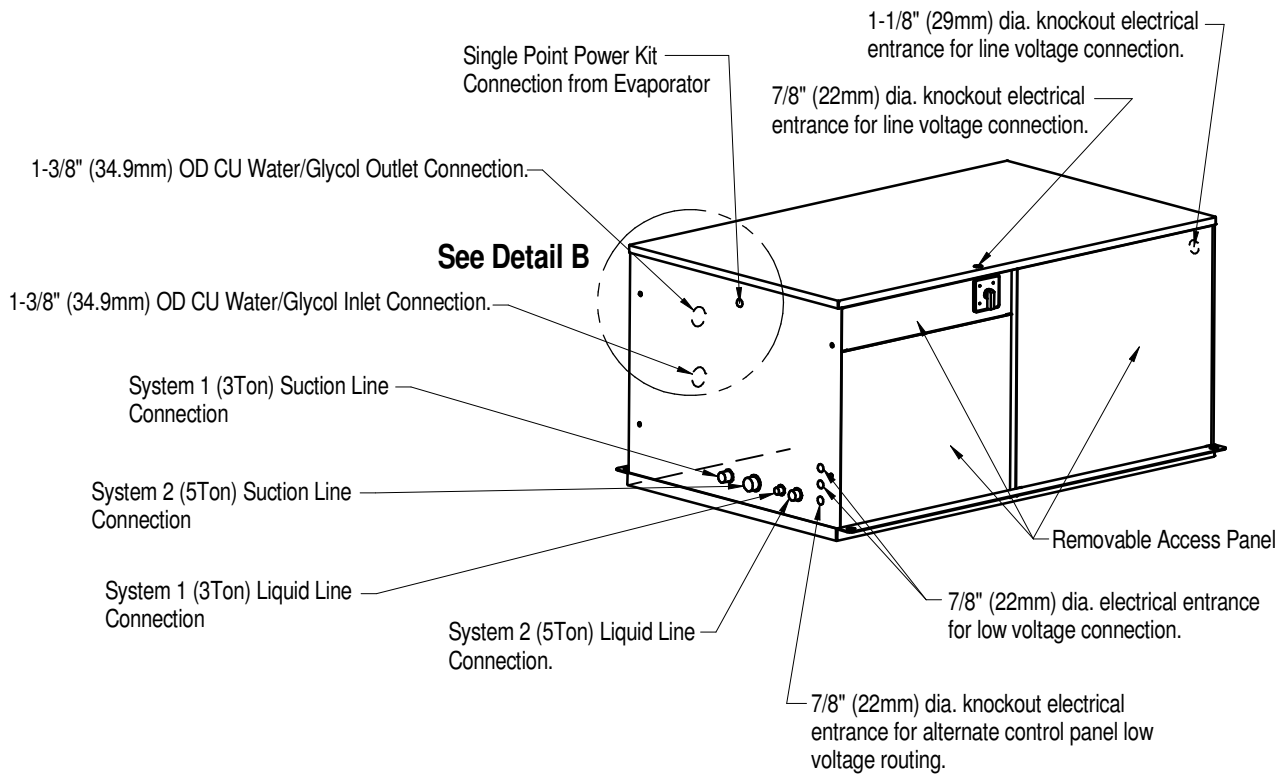

**Detail "B"**  
**Rear of Unit**



**VERTIV™**

# LIEBERT® PFH

## CABINET DIMENSIONAL DATA CONDENSING MODULES W/ TOP AIR DISCHARGE

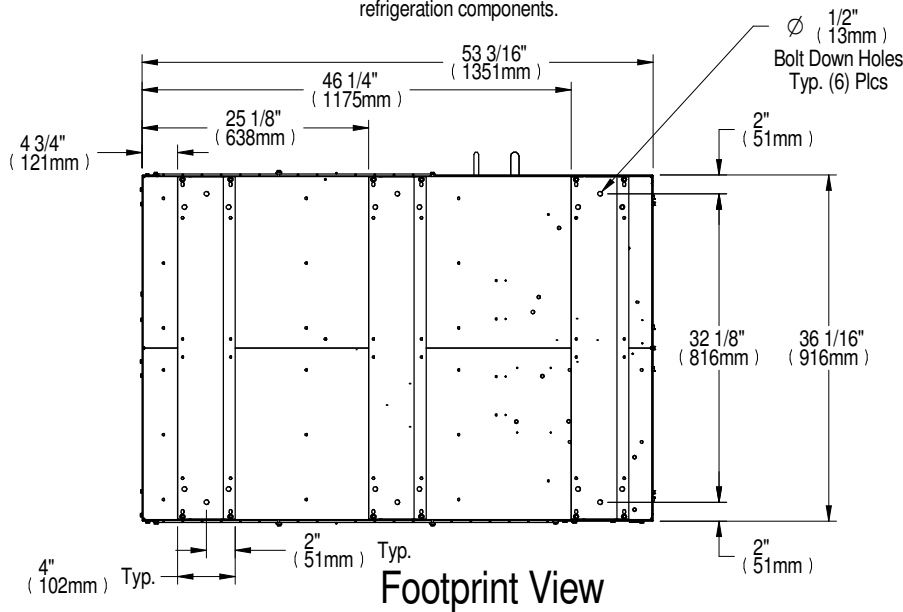
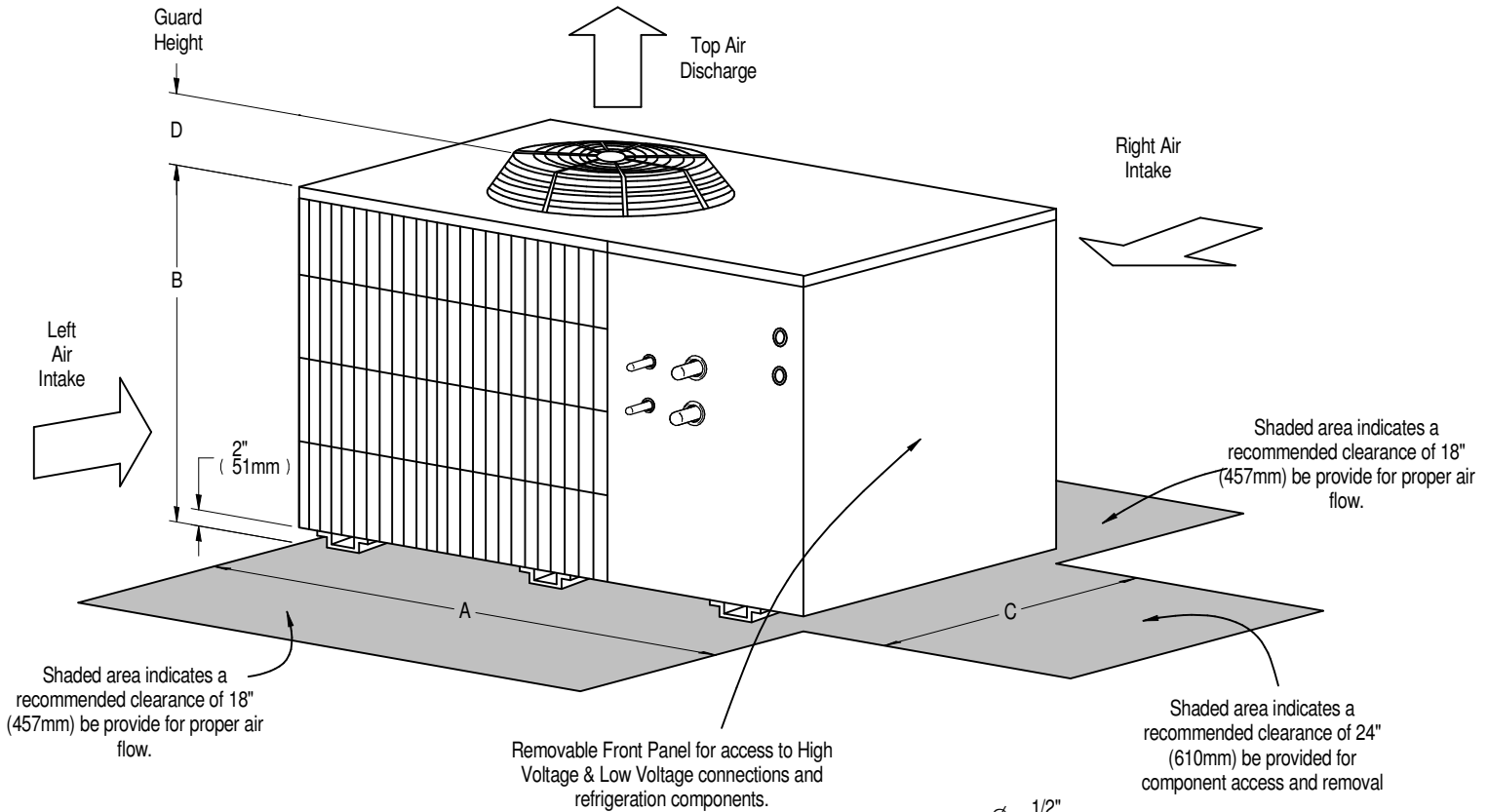

MODEL NUMBERS		DIMENSIONAL DATA IN. (mm)				MODULE WEIGHT
60HZ	50HZ	A	B	C	D	lbs. (kg) net.
PFH067A- H	PFH066A- H	53 (1343)	36 1/4 (918)	38 1/2 (978)	5 1/2 (140)	488 (222)
PFHZ67A- L	PFHZ66A- L					570 (259)
PFH096A- L	PFH095A- L					



**VERTIV™**

# LIEBERT® MCD & LIEBERT® PFH

## GENERAL ARRANGEMENT DIAGRAM

### 8 TON SPLIT SYSTEM AIR COOLED & CHILLED WATER FAN COIL (TWO CIRCUITS REQUIRED, ONE CIRCUIT SHOWN FOR CLARITY)

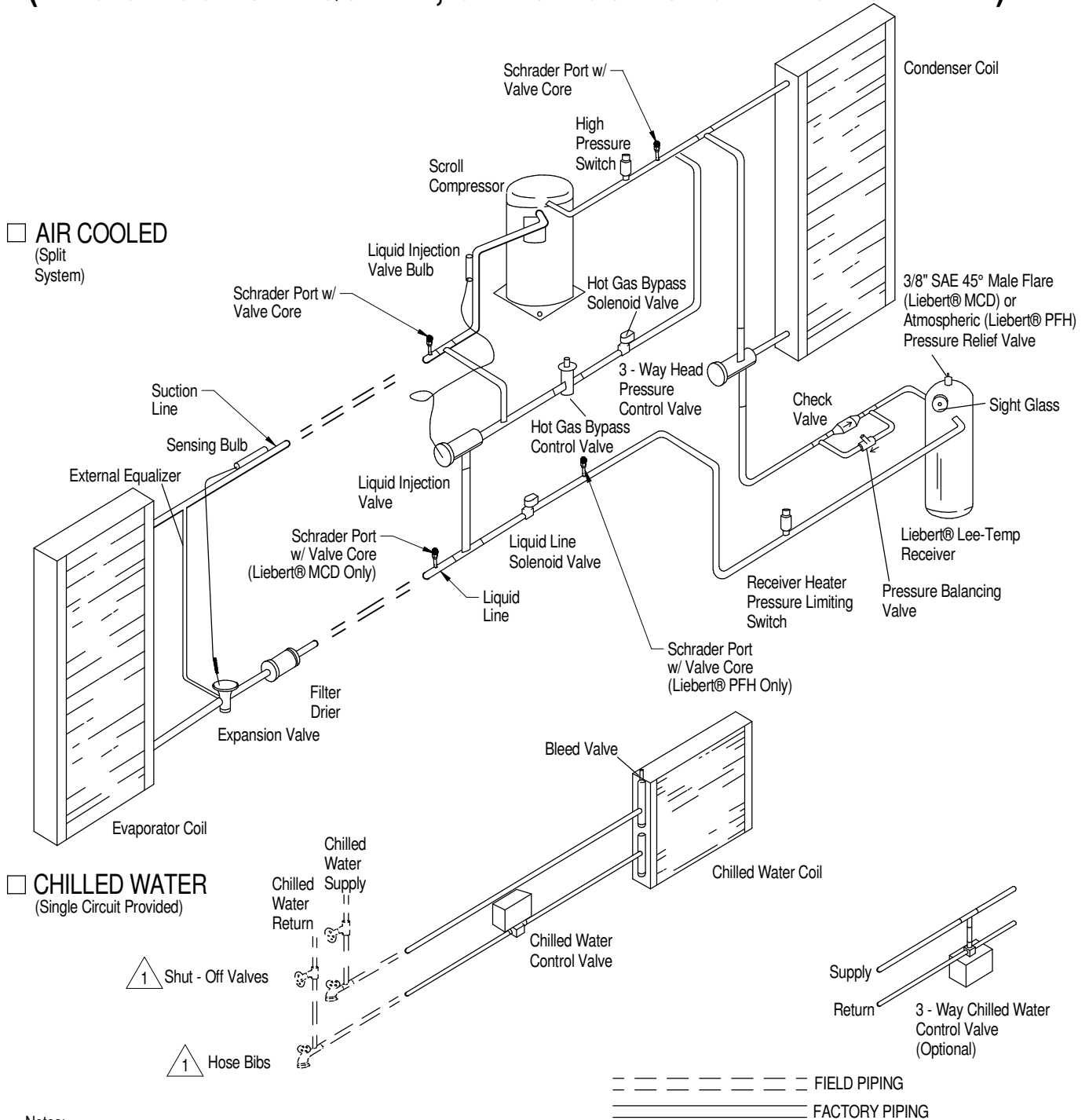

Notes:

1. Components are not supplied by Liebert but are required for proper circuit operation and maintenance.



**VERTIV™**

# LIEBERT® MINI-MATE2

## GENERAL ARRANGEMENT DIAGRAM 8 TON HOT WATER REHEAT COIL OPTION

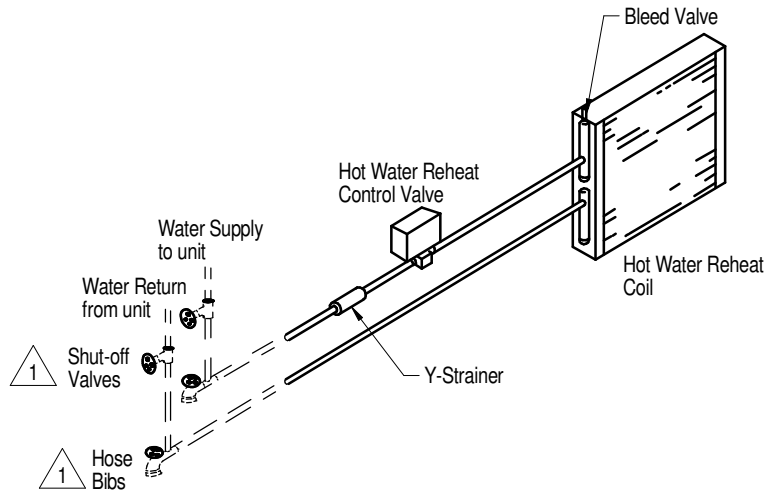

OPTIONAL HOT WATER REHEAT(2-WAY VALVE)

(Hot Water Reheat only available on Chilled Water Units)

===== FACTORY PIPING  
 = = = = = FIELD PIPING

Notes:

1. Components are not supplied by Vertiv but are required for proper circuit operation and maintenance.



**VERTIV**

# LIEBERT® MINI-MATE2

## GENERAL ARRANGEMENT DIAGRAM 8 TON SPLIT SYSTEMS WATER/GLYCOL COOLED (TWO CIRCUITS REQUIRED, SINGLE CIRCUIT SHOWN FOR CLARITY)

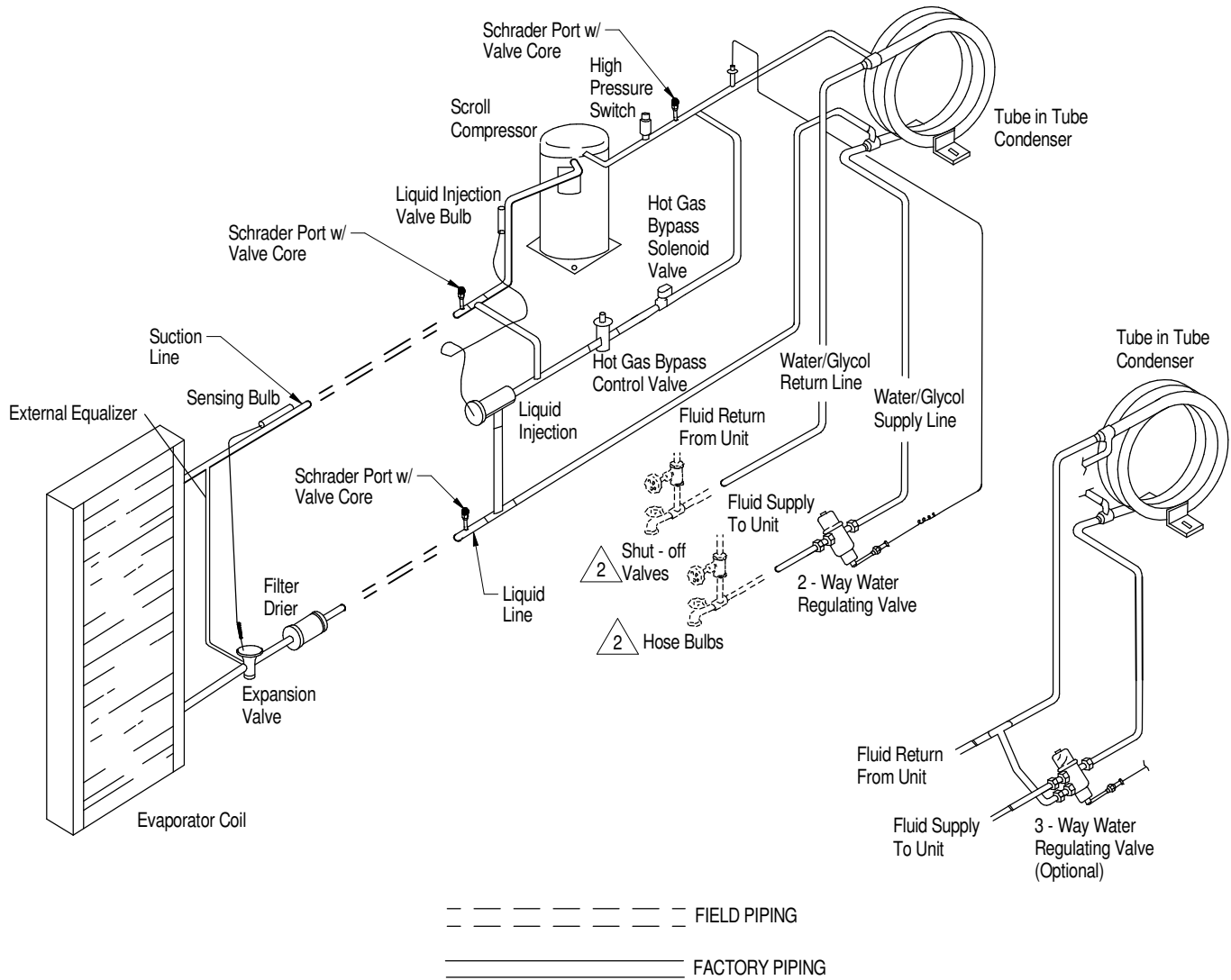

**Notes:**

1. Condenser water circuits are factory piped to form one (1) supply connection and one (1) return connection for unit.

2. Components are not supplied by Vertiv but are required for proper circuit operation and maintenance.



# LIEBERT® DRYCOOLER

## PIPING SCHEMATIC

### MULTIPLE DRYCOOLERS & COOLING UNITS ON COMMON GLYCOL LOOP

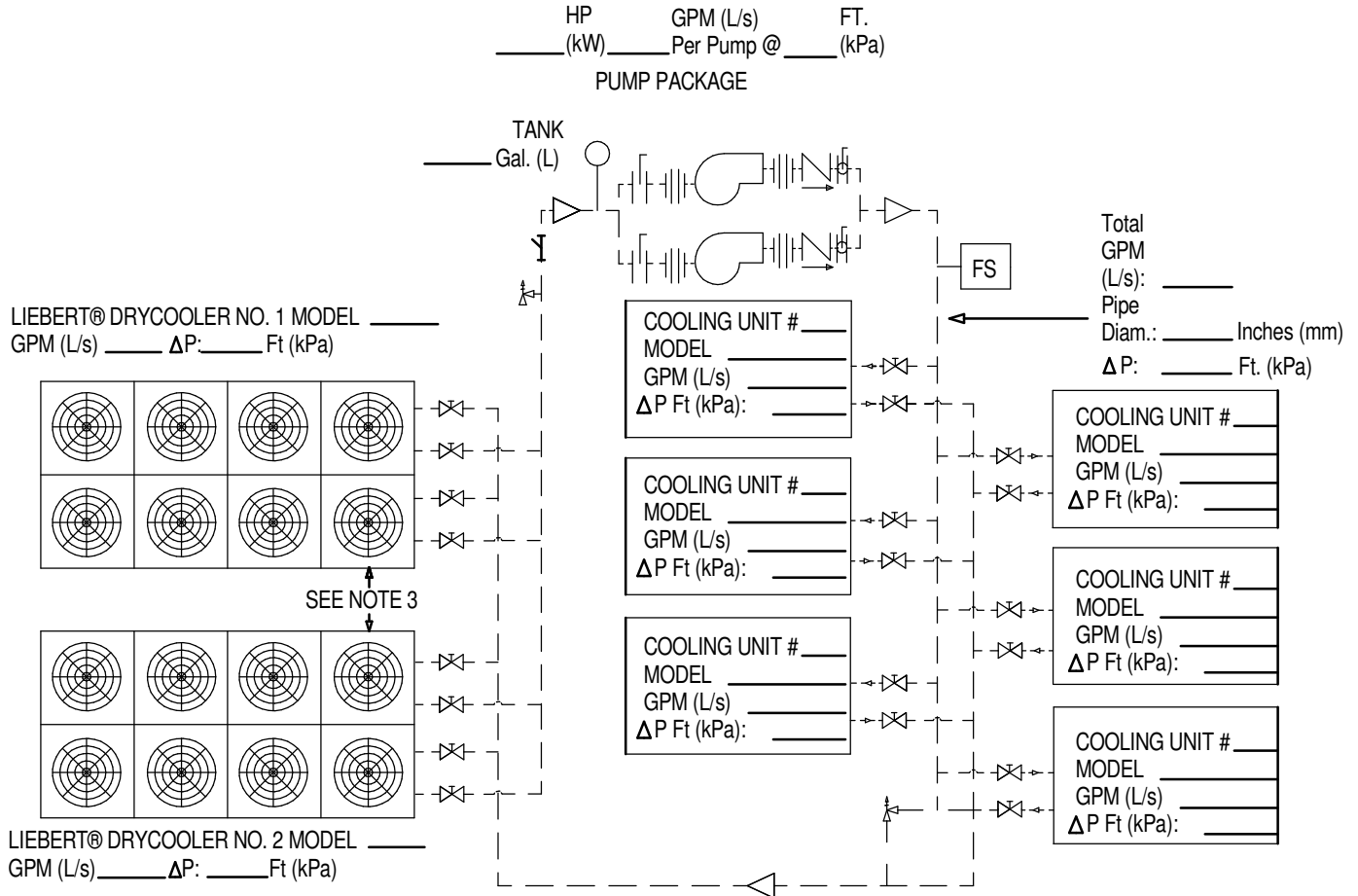

#### LEGEND

- GATE VALVE
- CHECK VALVE
- BUTTERFLY VALVE
- RELIEF VALVE
- UNION
- BALL OR FLOW CONTROL VALVE
- FLOW SWITCH
- $\Delta P$ : PRESSURE DROP
- STRAINER/FILTER

#### NOTES:

1. PRESSURE AND TEMPERATURE GAUGES (OR PORTS FOR SAME) ARE RECOMMENDED TO MONITOR COMPONENT PRESSURE DROPS AND PERFORMANCE.
2. FLOW MEASURING DEVICES, DRAIN AND BALANCING VALVES TO BE SUPPLIED BY OTHERS AND LOCATED AS REQUIRED.
3. SEE PRODUCT LITERATURE FOR INSTALLATION GUIDELINES AND CLEARANCE DIMENSIONS.
4. DRAWING SHOWS DUAL PUMP PACKAGE. ALTERNATE PUMP PACKAGES WITH MORE PUMPS MAY BE CONSIDERED, CONSULT SUPPLIER.
5. DEPENDING ON THE LIEBERT® DRYCOOLER COIL CIRCUITING IT MAY HAVE 2 IN/OUT OR 4 IN/OUT CONNECTION POINTS.
6. INSTALL EXPANSION OR COMPRESSION TANK AT THE HIGHEST POINT OF THE SYSTEM.



**VERTIV**

# LIEBERT® MINI-MATE2

## PRIMARY CONNECTION LOCATIONS 8 TON EVAPORATOR OR CHILLED WATER UNIT

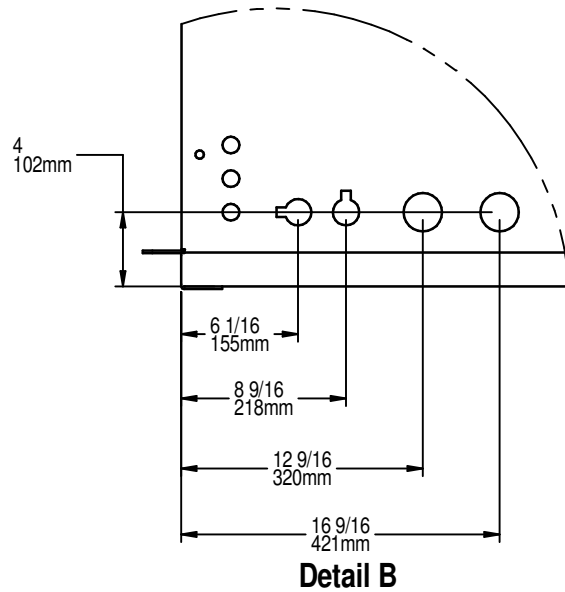
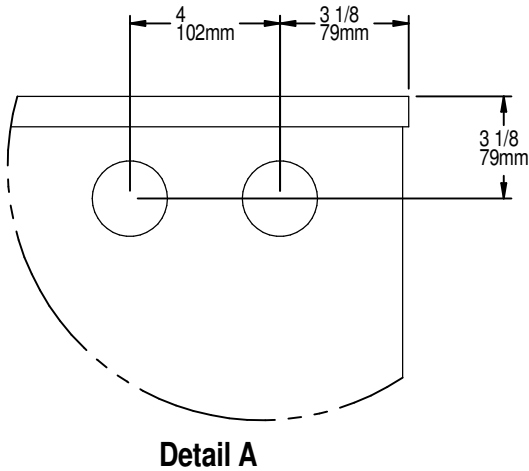
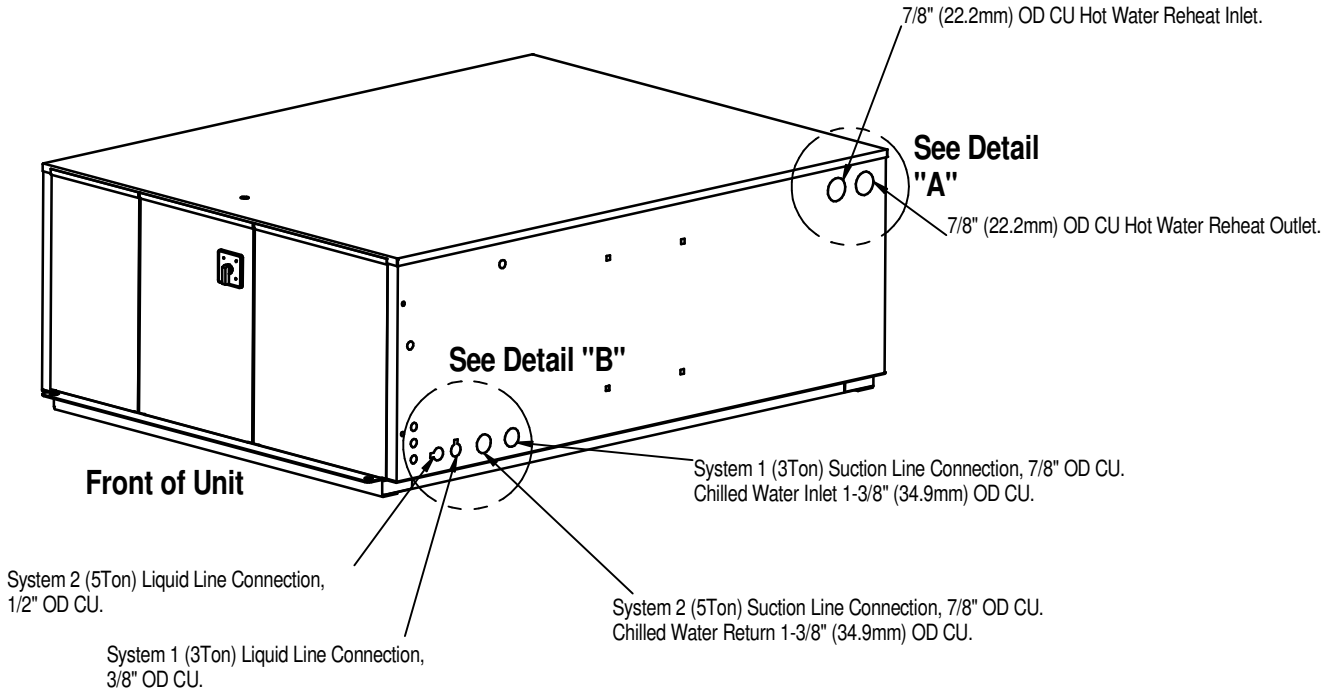



**VERTIV**

# LIEBERT® MINI-MATE2

## PRIMARY CONNECTION LOCATIONS 8 TON EVAPORATOR OR CHILLED WATER UNIT

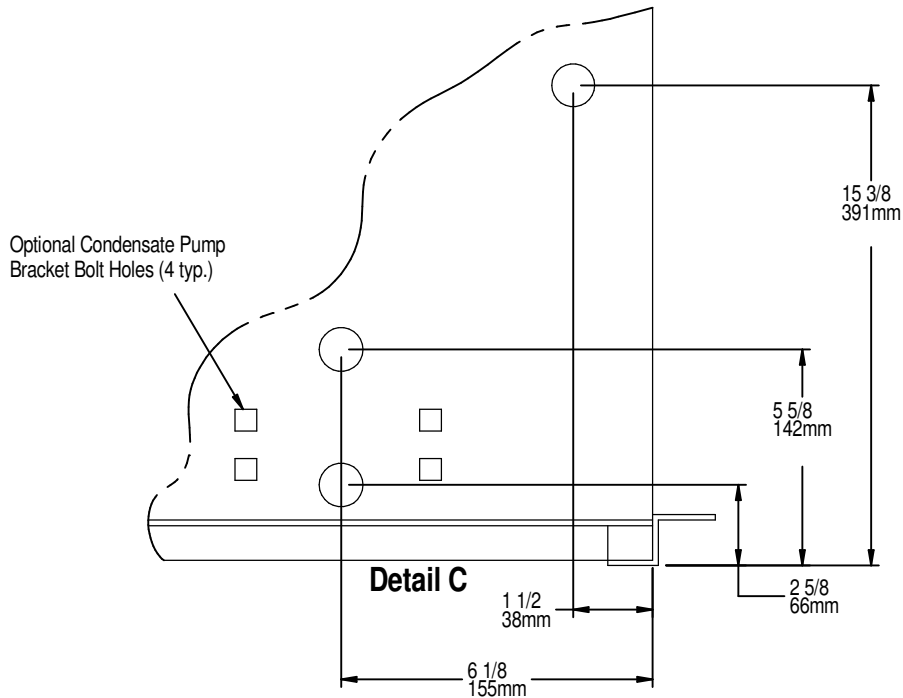
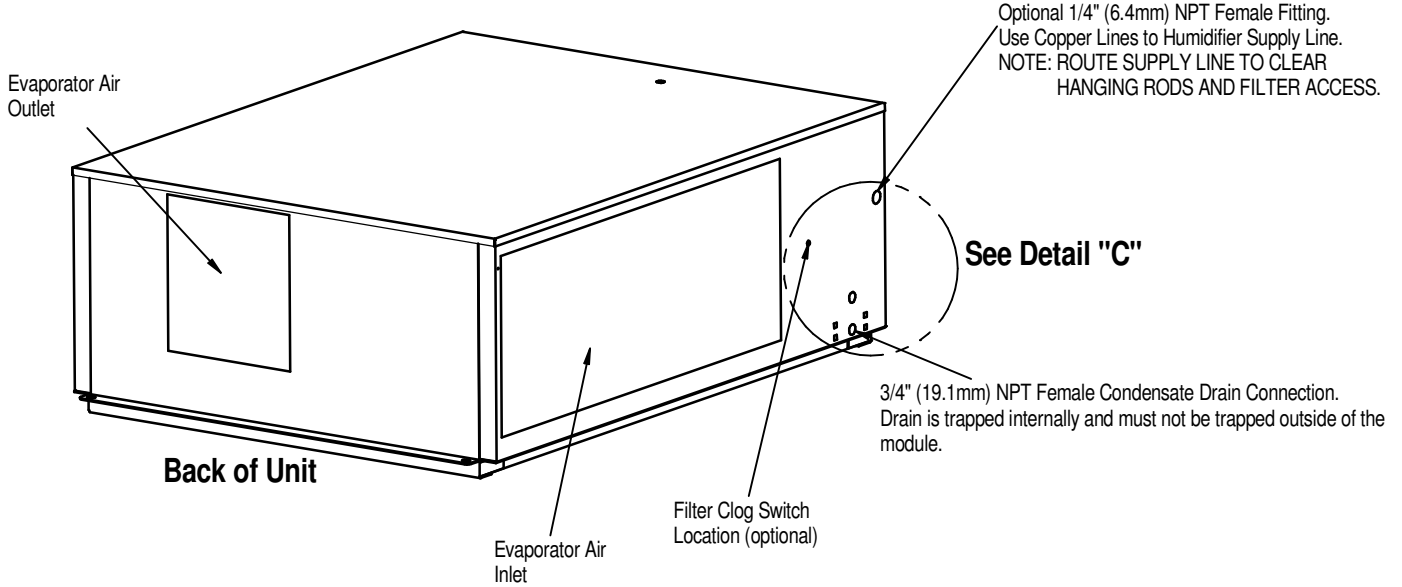



**VERTIV™**

# LIEBERT® MINI-MATE2

## SMALL SYSTEMS 8 TON CONDENSATE PUMP CONNECTION (OPTIONAL FIELD INSTALLED)

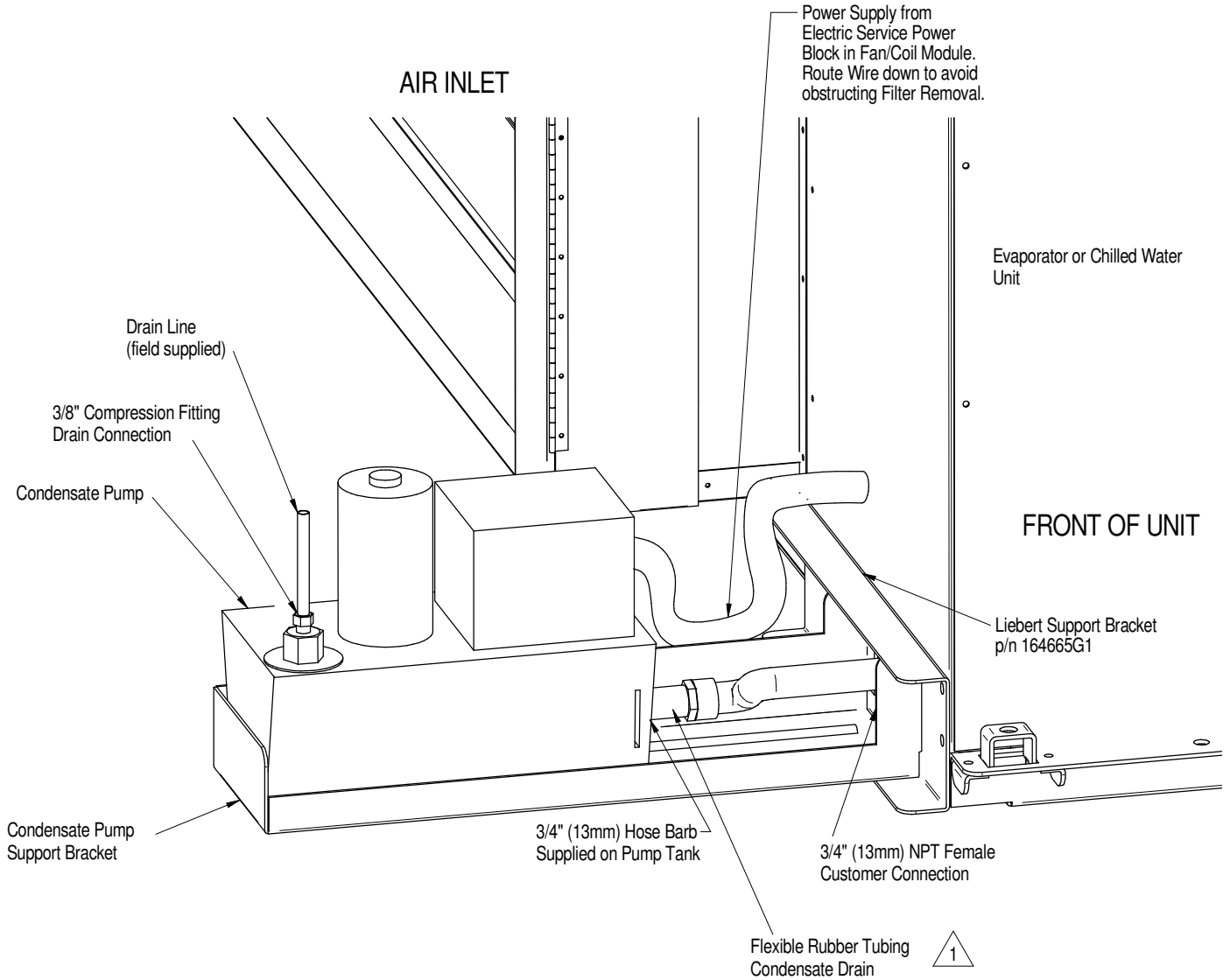

Notes:

1. 3/4" (19mm) Flexible Rubber Tubing Assembly (supplied with Pump Kit) must be installed on pump end.
2. The Auxiliary Float Switch included with pump must be field interlocked with unit control to enable unit shutdown feature. Wire to evaporator terminal per unit schematic.
3. Refer to DPN003401 for installation instructions.

Form No.: DPN001040\_REV14



## ELECTRICAL FIELD CONNECTIONS 8 TON EVAPORATOR & CHILLED WATER MODELS

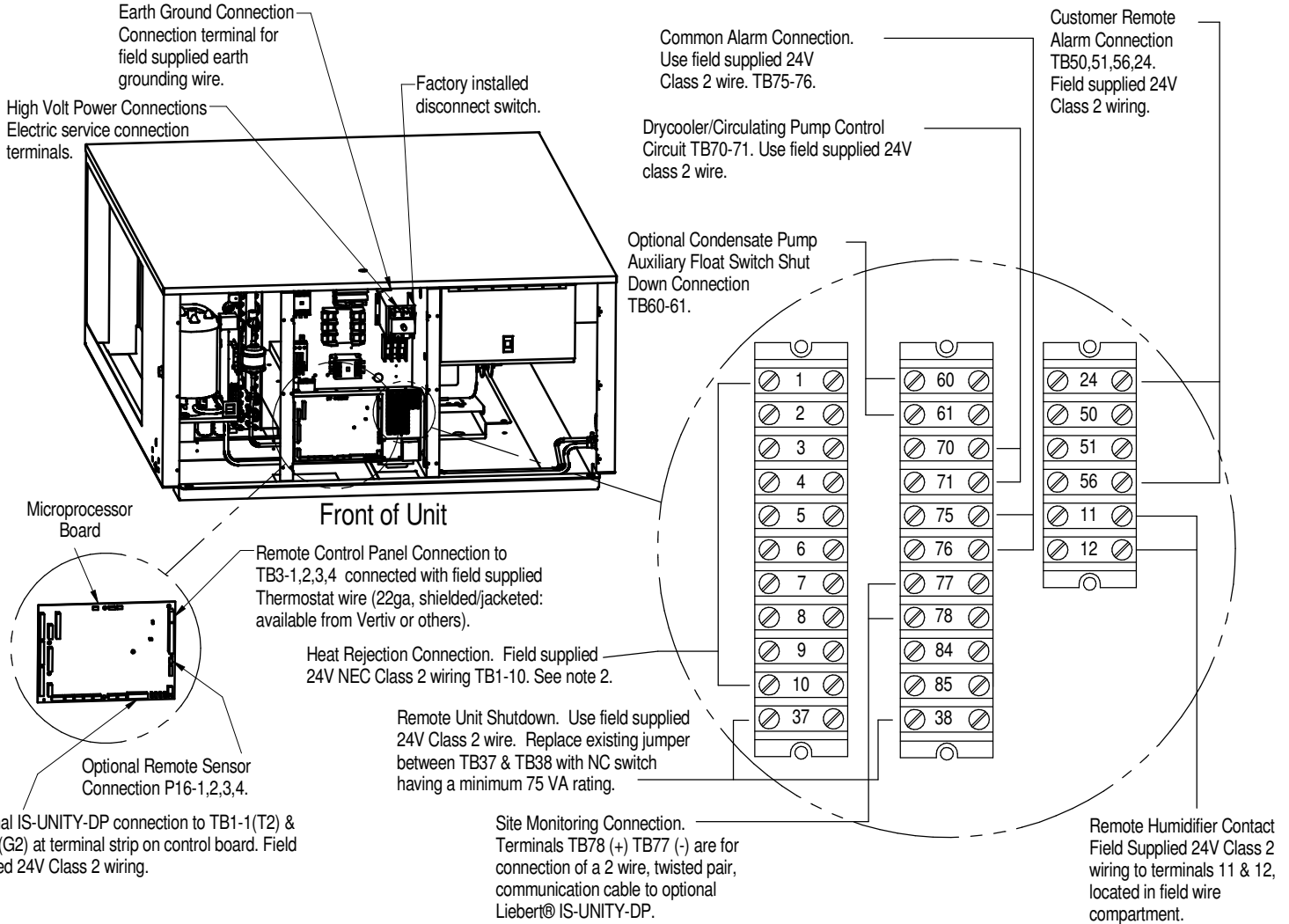

Optional IS-UNITY-DP connection to TB1-1(T2) & TB1-5(G2) at terminal strip on control board. Field supplied 24V Class 2 wiring.

Field supplied unit disconnect switch when factory unit disconnect switch is not supplied.

Entrance for customer high volt connections.

Electric service not by Vertiv.

Electrical entrance for optional condensate pump on left side of unit.

Entrance for customer low voltage connections.

Field supplied, field wired thermostat wire to remote wall box.

Entrance for customer low voltage connections

Field supplied 24V (NEC Class2 wiring) to condensing unit. (if applicable)

**Notes:**

1. Refer to specification sheet for full load amp and wire size amp rating.
2. Control Voltage Wiring must be a minimum of 16GA (1.3mm) for up to 75' (23m) or not to exceed 1 volt drop in control line.



**VERTIV™**

# LIEBERT® MINI-MATE2

## OPTIONAL FIELD INSTALLED SINGLE POINT POWER KIT 8 TON AIR & WATER/GLYCOL COOLED MODELS

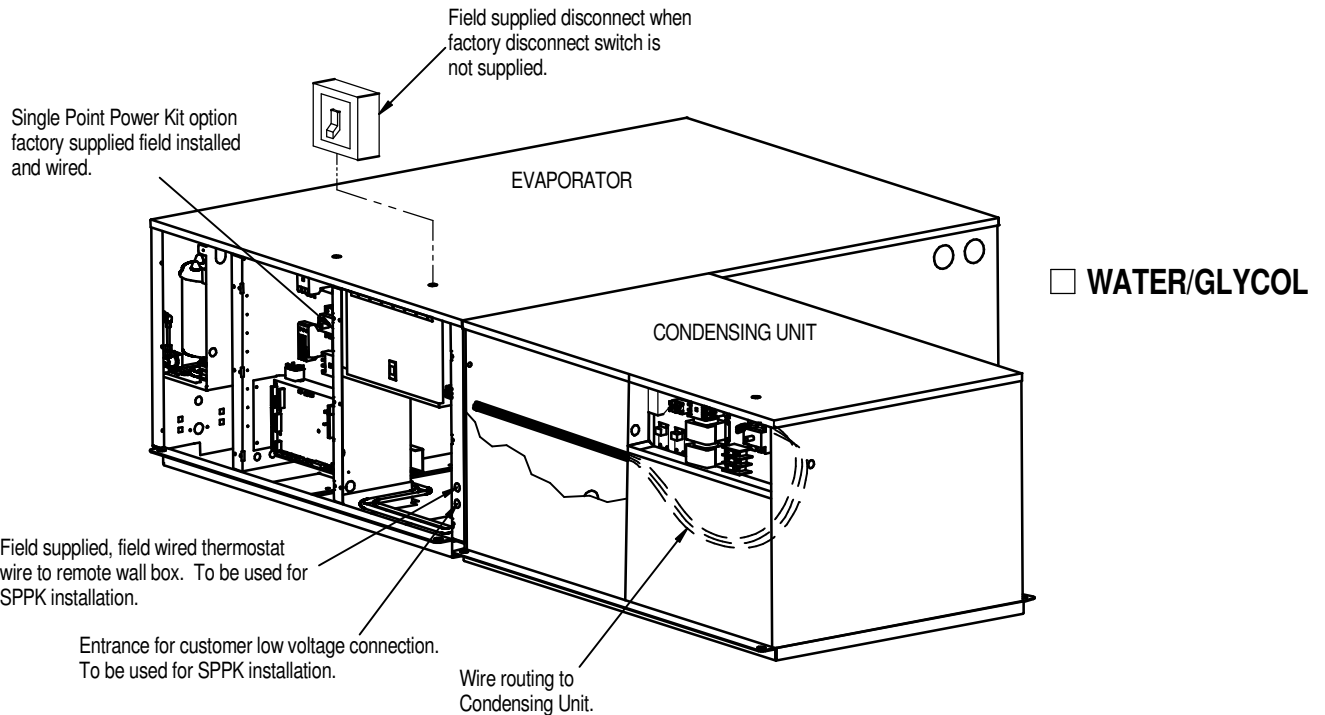
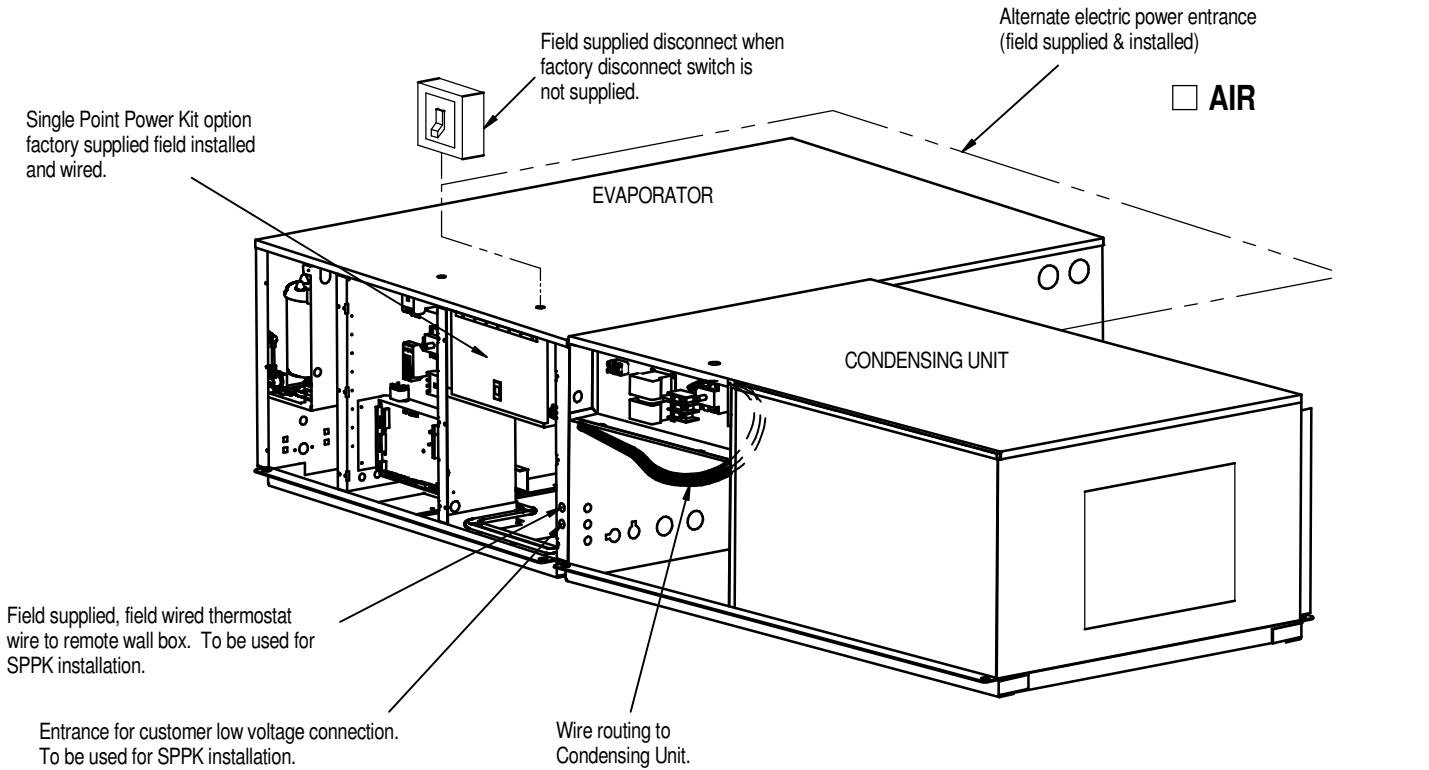

**Notes:**

- 1. Single Point Power Kit should be mounted inside the evaporator before installing the unit to the ceiling.



**VERTIV™**

# LIEBERT® MINI-MATE2

## OPTIONAL FIELD INSTALLED SINGLE POINT POWER KIT 8 TON MODELS

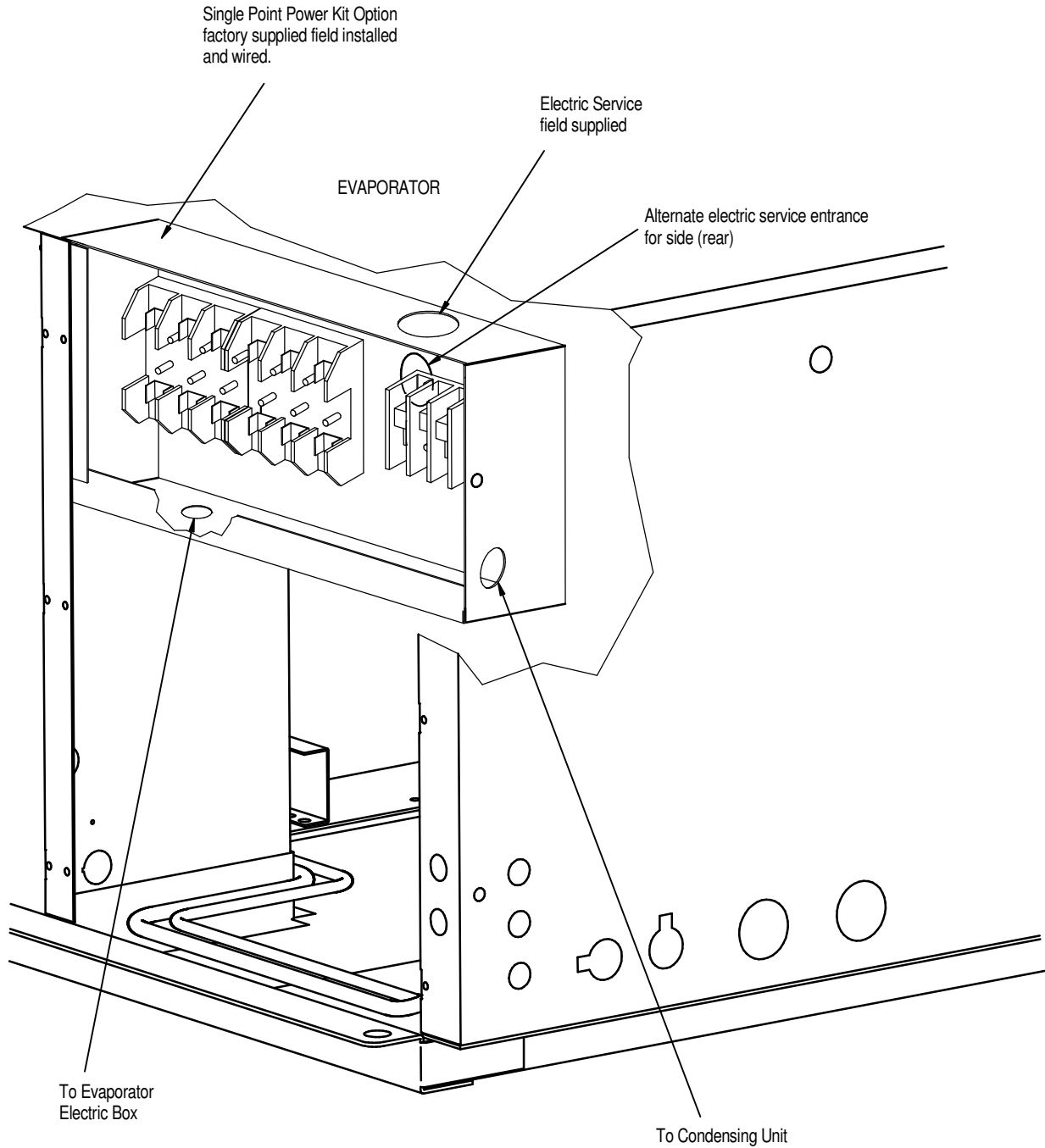

**Notes:**

1. Single Point Power Kit should be mounted inside the evaporator before installing the unit to the ceiling.



**VERTIV™**

# LIEBERT® MINI-MATE2

## GENERAL ARRANGEMENT & DIMENSIONAL DATA UNIT MOUNTED LIEBERT® IS-UNITY-DP ON 8 TON FOR BMS CONNECTIVITY

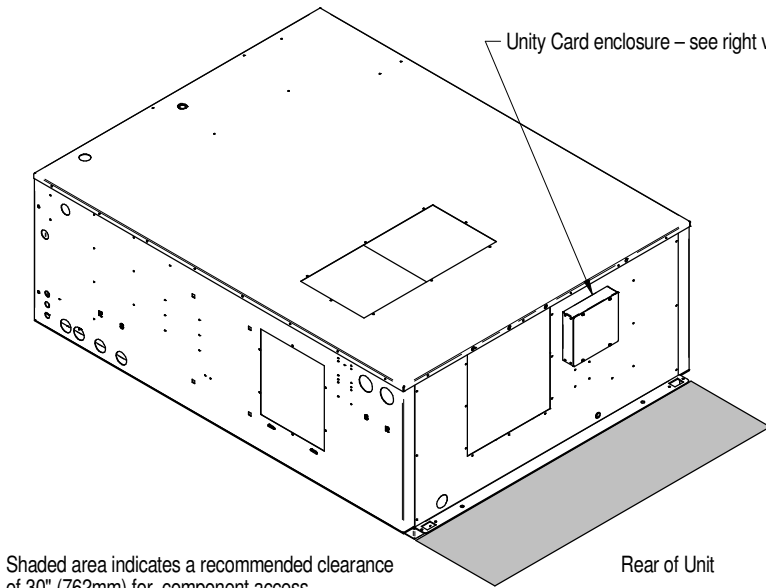

Shaded area indicates a recommended clearance of 30" (762mm) for component access and removal

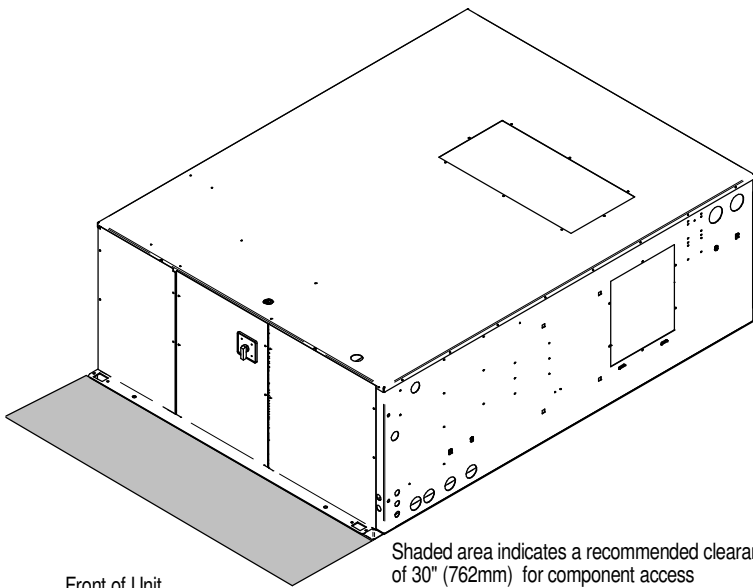

Shaded area indicates a recommended clearance of 30" (762mm) for component access and removal

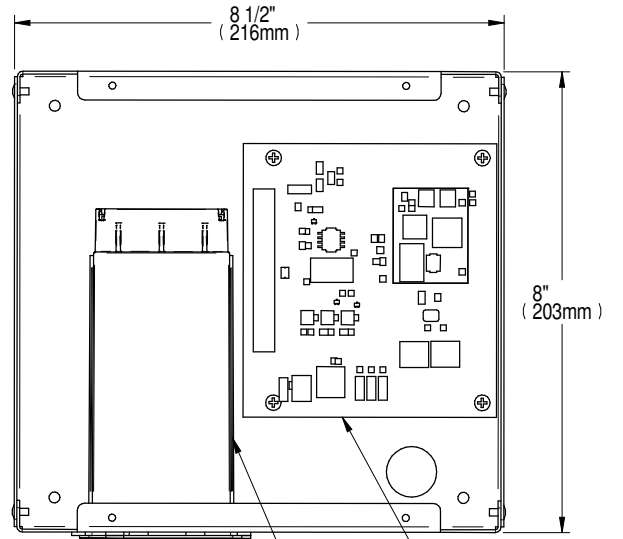

Cover removed for clarity. Removal not required for making field communication connections.

Liebert® IS-UNITY-DP CARD

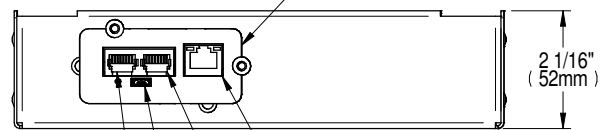

ETHERNET port  
RS-485 port (using adaptor)

NOT USED  
NOT USED

**BOTTOM VIEW**

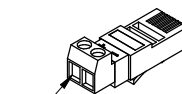

Adaptor plugged into BMS 485 port when unit is shipped

Notes:

1. Refer to DPN004854 for field communication connections.



**VERTIV™**

# LIEBERT® MINI-MATE2

## GENERAL ARRANGEMENT & DIMENSIONAL DATA

### WALL MOUNTED LIEBERT® IS-UNITY-DP CARD FOR BMS CONNECTIVITY

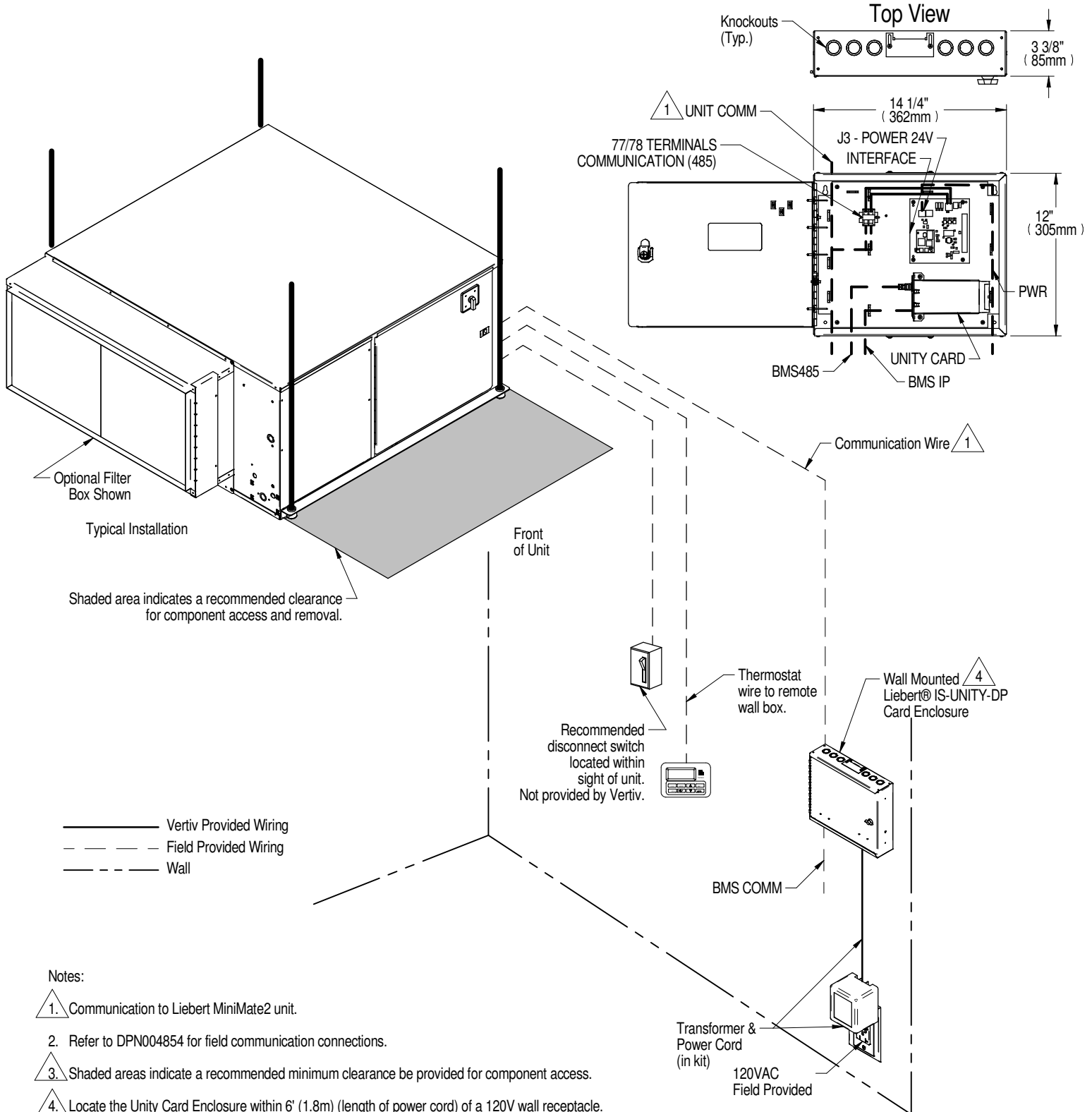

## BMS COMMUNICATION CONNECTION OPTIONS LIEBERT® MINI-MATE2 & LIEBERT® DATAMATE

**BMS IP/485**  
(1 Cooling Unit only)

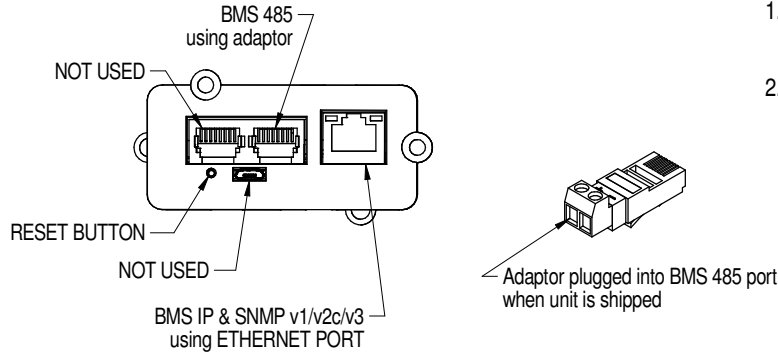

1. Building Management System (BMS) Protocols
  - \*BACNet over IP/485
  - \*Modbus over IP/485
2. Communication wiring is field supplied
  - IP - use CAT5e cable or greater
  - 485 - use EIA 485 rated, shielded, twisted pair cable, 22-18AWG.
  - Must be rated to meet local codes and conditions.

### UNIT TO INTERFACE BOARD CONNECTIONS

	UNIT		UNIT MOUNTED KITs*		WALL MOUNTED KITs**	
	TERMINAL/PLUG	POSITION	TERMINAL/PLUG	POSITION	TERMINAL/PLUG	POSITION
<b>Liebert® Mini-Mate2 1-5 Ton</b>						
COMMUNICATION (485)	TB4	1 / 2	J2	2 / 1	77 / 78	N/A
POWER 24V	20, 21	N/A	J3	1 / 2	J3	1 / 2
<b>Liebert® Mini-Mate2 8 Ton</b>						
COMMUNICATION (485)	77, 78	N/A	J2	2 / 1	77 / 78	N/A
POWER 24V	TB1	4 / 8	J3	1 / 2	J3	1 / 2
<b>Liebert® DataMate</b>						
COMMUNICATION (485)	TB5	77 / 78	N/A	N/A	77 / 78	N/A
POWER 24V	N/A	N/A	N/A	N/A	J3	1 / 2

#### Notes

Terminals are presented in order of connection. For example, TB4-1 connects to J2-2.

\* Unit mounted kits are provided with Unit Comm & power wire harnesses; BMS Comm are field provided.

\*\* Wall mounted kits are provided with power wire harness and 120 Volt wall outlet transformer. Unit Comm & BMS Comm are field provided.

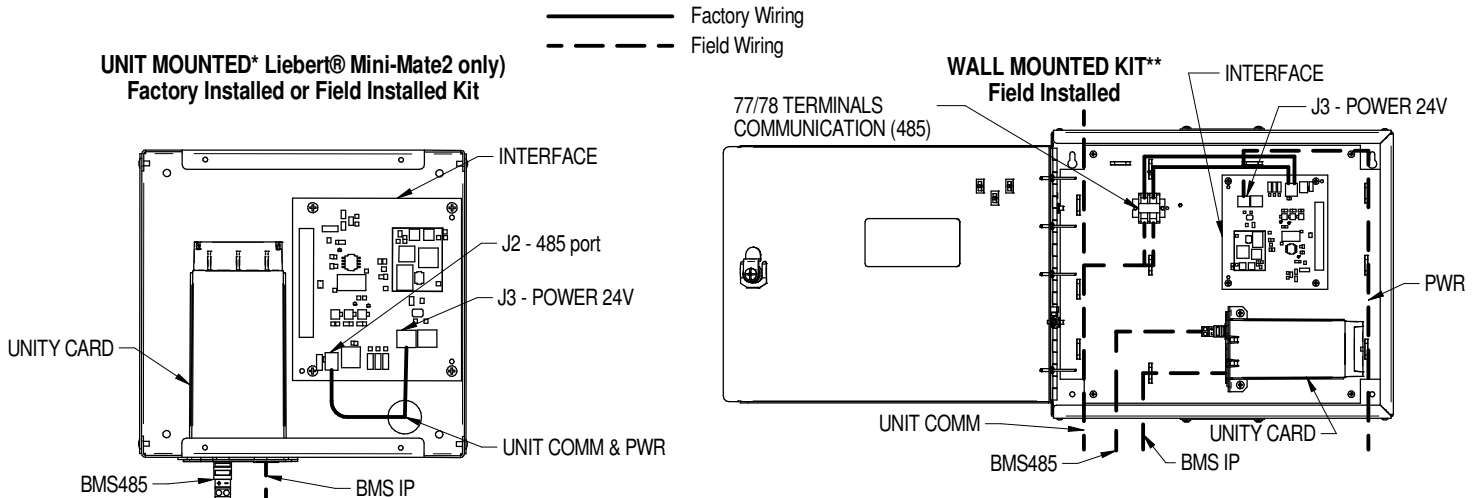



**VERTIV™**

# LIEBERT® MINI-MATE2

## ELECTRICAL CONNECTIONS

### 8 TON AIR COOLED INDOOR CONDENSING MODULE

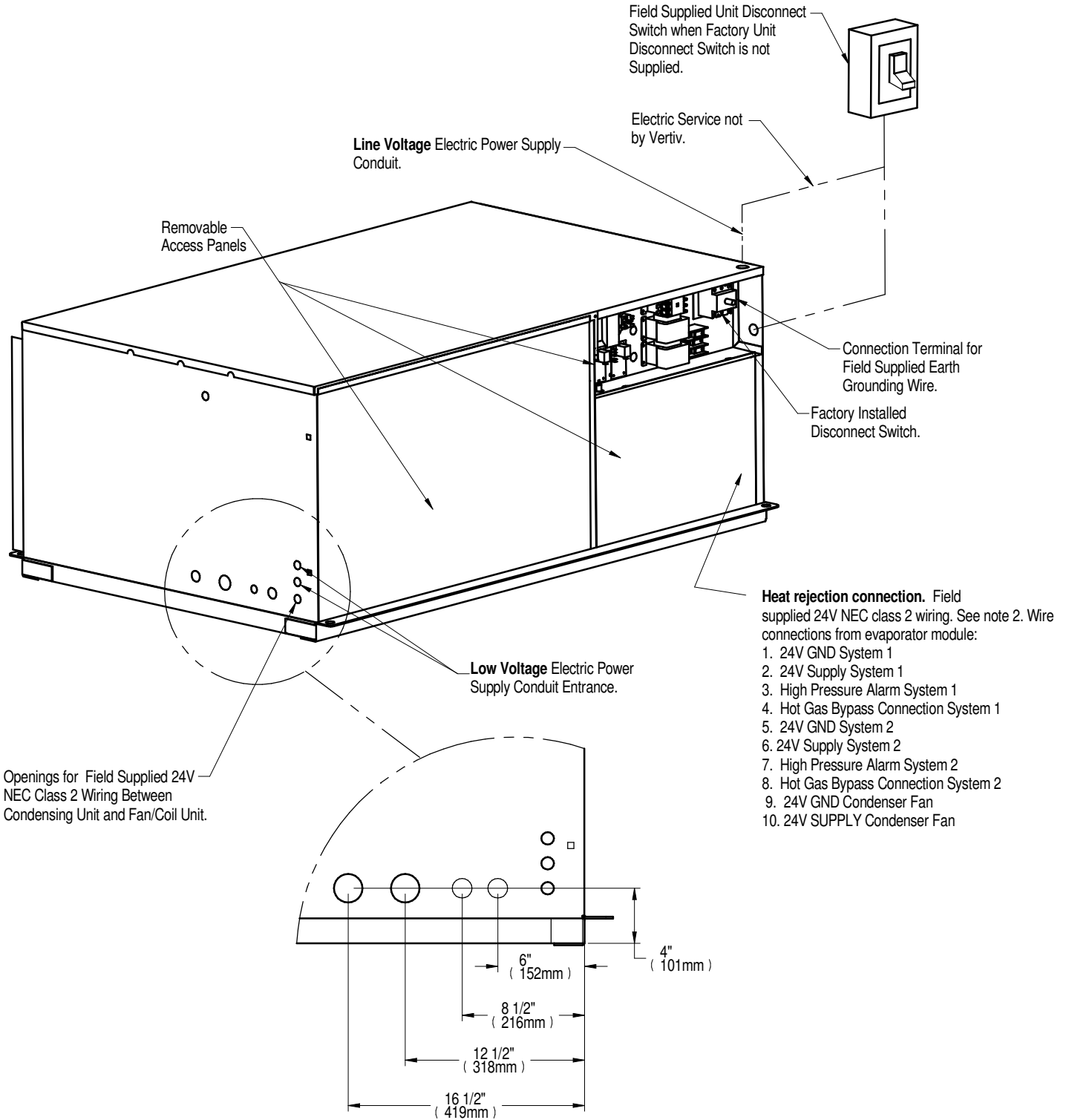

**Notes:**

1. Refer to specification sheet for full load amp and wire size ratings.
2. Control voltage wiring must be a minimum of 16GA (1.3mm) for up to 75' (23m) or not to exceed 1 volt drop in control line.

Form No.: DPN001040\_REV14



**VERTIV™**

# LIEBERT® MINI-MATE2

## ELECTRICAL FIELD CONNECTIONS 8 TON WATER/GLYCOL COOLED INDOOR CONDENSING MODULE

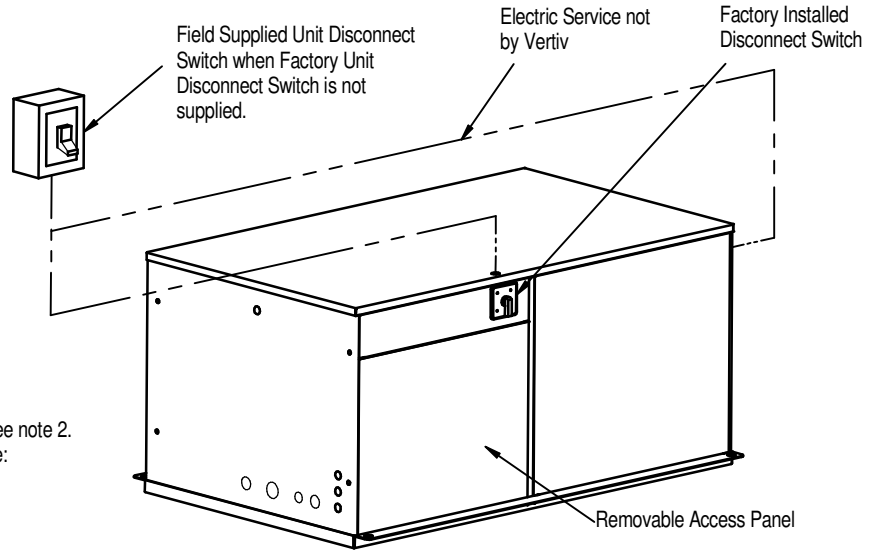

- Heat rejection connection  
 Field supplied 24V NEC class 2 wiring. See note 2.  
 Wire connections from evaporator module:
- 1 24V GND System 1
  - 2 24V Supply System 1
  - 3 High Pressure Alarm System 1
  - 4 Hot Gas Bypass Connection System 1
  - 5 24V GND System 2
  - 6 24V Supply System 2
  - 7 High Pressure Alarm System 2
  - 8 Hot Gas Bypass Connection System 2

Field Supplied 24V NEC Class 2 Wiring between Glycol Condensing Unit and Liebert® Drycooler

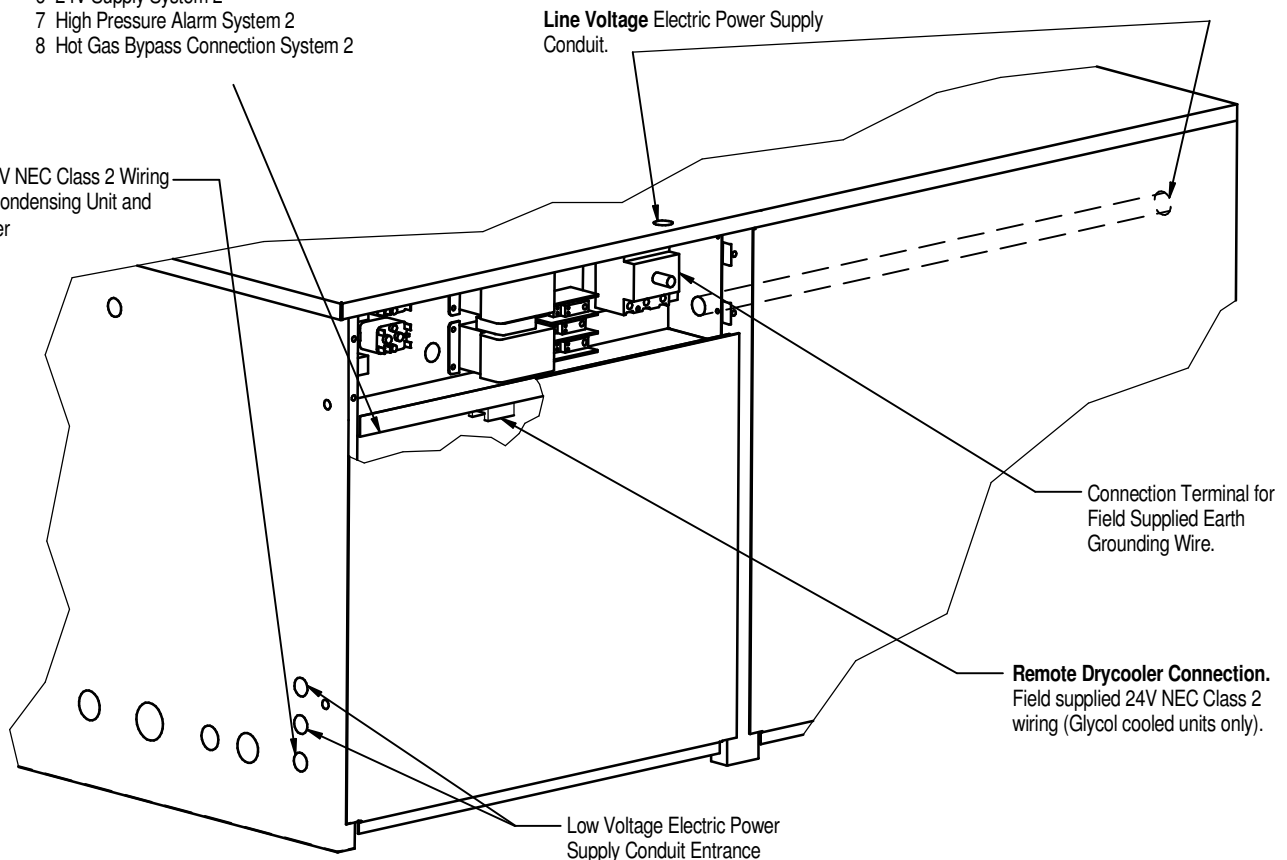

**Notes:**

1. Refer to specification sheet for full load amp and wire size ratings.
2. Control voltage wiring must be a minimum of 16GA (1.3mm) for up to 75' (23m) or not to exceed 1 volt drop in control line.

This page intentionally left blank

### **Connect with Vertiv on Social Media**



<https://www.facebook.com/vertiv/>



<https://www.instagram.com/vertiv/>



<https://www.linkedin.com/company/vertiv/>



<https://www.twitter.com/Vertiv/>



---

Vertiv.com | Vertiv Headquarters, 505 N Cleveland Ave, Westerville, OH 43082 USA

©2026 Vertiv Group Corp. All rights reserved. Vertiv™ and the Vertiv logo are trademarks or registered trademarks of Vertiv Group Corp. All other names and logos referred to are trade names, trademarks or registered trademarks of their respective owners. While every precaution has been taken to ensure accuracy and completeness here, Vertiv Group Corp. assumes no responsibility, and disclaims all liability, for damages resulting from use of this information or for any errors or omissions.

SL-10537\_REV15\_04-26