



Liebert® PPC Large Power and Distribution Cabinet

Installer/User Guide

400 kVA to 1000 kVA, Three-Phase, 60 Hz PDU

The information contained in this document is subject to change without notice and may not be suitable for all applications. While every precaution has been taken to ensure the accuracy and completeness of this document, Vertiv assumes no responsibility and disclaims all liability for damages result from use of this information or for any errors or omissions.

Refer to local regulations and building codes relating to the application, installation, and operation of this product. The consulting engineer, installer, and/or end user is responsible for compliance with all applicable laws and regulations relation to the application, installation, and operation of this product.

The products covered by this instruction manual are manufactured and/or sold by Vertiv. This document is the property of Vertiv and contains confidential and proprietary information owned by Vertiv. Any copying, use, or disclosure of it without the written permission of Vertiv is strictly prohibited.

Names of companies and products are trademarks or registered trademarks of the respective companies. Any questions regarding usage of trademark names should be directed to the original manufacturer.

Technical Support Site

If you encounter any installation or operational issues with your product, check the pertinent section of this manual to see if the issue can be resolved by following outlined procedures.

Visit <https://www.vertiv.com/en-us/support/> for additional assistance.

TABLE OF CONTENTS

1 Important Safety Information	1
2 Introduction	3
3 Equipment Handling and Pre-Install Preparation	5
3.1 Preliminary Inspection and Unpacking	5
3.2 Equipment Handling and Moving	5
3.3 Installation Location Considerations	6
3.4 Removing the Unit from the Shipping Pallet	7
4 Power and Control Wiring Installation	9
4.1 Input Power Connection	10
4.2 System Grounding	10
4.3 Grounding Electrode Conductor	10
4.4 Output Power Connection	11
4.5 Control Wiring Connections for DPM	12
4.5.1 Emergency Power Off (EPO) Loop	12
4.5.2 Auto or Manual Restart Selection	13
4.5.3 High Temperature Shutdown Selection	14
4.5.4 Input Alarm Connections	14
4.5.5 Output Alarm Connections	14
5 Equipment Inspection and Startup	17
5.1 Internal Inspection	17
5.2 Unit Startup	18
5.3 Monitoring System Check	19
6 Operation	21
6.1 Emergency Shutdown	21
6.2 Normal System Shut down	21
6.3 Normal System Startup	21
6.4 Manual Restart	22
6.5 Vertiv™ Liebert® DPM	22
6.5.1 Alarms and Alarm Thresholds	23
6.5.2 Metered Parameters	24
6.5.3 Remote Monitoring Communication	24
7 Maintenance	25
7.1 Repair	25
7.2 Preventive Maintenance	25
7.3 Inspection Schedule	25
7.3.1 Fuse List	26
Appendices	27

Appendix A: Technical Support and Contacts	27
Appendix B: Equipment Inspection and Startup Checklist	29

1 Important Safety Information

Read this entire manual before installing or operating the system.



WARNING! Risk of cutting bands under tension. Can cause injury or death. The shipping bands may be under tension. Use appropriate eye, face, and hand protection to safeguard against injury from band backlash.



WARNING! Risk of electric shock. Can cause injury or death. Verify that all incoming line voltage (power) and low voltage (control) circuits are de-energized and locked out before installing cables or making connections in the junction box or in the unit. Equipment inspection and startup must be performed only by trained personnel. Lethal voltages are present during startup procedures. Electrical safety precautions must be followed throughout inspection and startup.

Only properly trained and qualified service personnel must perform maintenance on the Vertiv™ Liebert® PPC Large Power and Distribution Cabinet. All voltage sources to the unit must be disconnected before inspecting or cleaning within the cabinet.

Lethal voltages exist within the equipment during operation. Observe all warnings and cautions in this manual. Failure to comply may result in serious injury or death. Obtain qualified service for this equipment as instructed.

The monitoring system contains a lithium battery for memory backup. Danger of explosion if the battery is incorrectly replaced. Replace only with the same or equivalent type. Dispose of used batteries according to the manufacturer's instructions.



WARNING! Risk of electric shock. Can cause injury or death. All power and control wiring must be installed by licensed electricians and must comply with the NEC and applicable codes.



WARNING! Risk of improper handling. Can cause equipment damage, injury, or death. The Vertiv Liebert PPC is heavy. Its weight ranges from 2750 lb (1312 kg) to 5788 lb (2625 kg). The unit must not be loosened from the shipping pallet until after all handling by forklift or pallet jack is completed.

Electromagnetic Compatibility—The Vertiv Liebert PPC Large Power and Distribution Cabinet complies with the limits for a class A digital device, pursuant to part 15 of the FCC rules.

Operation is subject to the conditions below:

- This device may not cause harmful interference.
- This device must accept any interference received, including interference that may cause undesired operation.

Operating this device in a residential area is likely to cause harmful interference that users must correct at their own expense.

The Vertiv Liebert PPC Large Power and Distribution Cabinet complies with the requirements of EMC Directive 2014/30/EU and the published technical standards. Continued compliance requires installation in accordance with these instructions and use of accessories approved by Vertiv.

This page intentionally left blank

2 Introduction

The variations of the Vertiv™ Liebert® PPC Power Distribution Unit covered in this document are larger models (400 kVA and above) that are equipped with the distributed power monitoring (DPM) system. The Vertiv Liebert PPC will typically have a main input circuit breaker, although it can be configured without a main circuit breaker for installations that have upstream over current protection. The distribution section allows for installation of up to (8) 600 AF or (4) 1200 AF breakers, which are fed from the output of the transformer. Monitoring cards and accessories are isolated for service and maintenance. This cabinet has both top and bottom entry/exit. The standard cabinet size is (60 x 48 x 85) in. (W X D X H). For the Vertiv Liebert PPC with larger transformers (1000 kVA and up), the cabinet size is increased to (84 x 60 x 85) in. (W X D X H).

This page intentionally left blank

3 Equipment Handling and Pre-Install Preparation

Read the entire manual before installing or operating the system. Upon receipt of the Vertiv™ Liebert® PPC, perform the following procedures to ensure a quality installation.

3.1 Preliminary Inspection and Unpacking

After the equipment is received:

- Inspect the shipping crates for damage or signs of mishandling before unpacking the units. Check the shock watch indicator, if applied.
- Open the shipping crates carefully. Use care to avoid puncturing the container with sharp objects that will damage the contents.
- Remove the packing and vapor barriers. Inspect the equipment for any obvious shipping damage.

NOTE: Do not loosen or remove the units from the shipping pallet until after all handling by forklift or pallet jack is completed. Perform a complete internal inspection only after the equipment is positioned in the installation location and prior to electrical hook-up.

If any damage is observed, document and photograph it, notify the local Vertiv representative, and contact Vertiv logistics at Amer.ReverseLogistics@vertiv.com.

3.2 Equipment Handling and Moving

The Vertiv Liebert PPC Large Power and Distribution Cabinet is bolted to a wooden pallet for handling with forklift equipment. When moving the Vertiv Liebert PPC Large Power and Distribution Cabinet, consider the following factors:

- **Check size and weight:** Refer to **Table 3.1** below and the drawings furnished with the unit for size and weight information. The unit is heavy; verify any surface that can support the full weight of the unit.
- **Plan the route:** Ensure that the route to the installation area is planned so that all passages are large enough to accommodate the unit and that the floors are strong enough to support the weight. Check all doorways, hallways, elevators, ramps, and other portions of the route to determine if there are any obstructions and to ensure each is large enough and strong enough to allow easy passage.
- **Move with care:** Move the unit to the installation area on the wooden pallet using a forklift or pallet jack. To prevent damage, we recommend removing the exterior panels before moving the unit. When replacing panels, make sure that all ground wires are reconnected.

Table 3.1 Unit Weights

Unit	Unit Weight, lb (kg)	Skidded Weight, lb (kg)
400 kVA	5207 (2362)	5349 (2427)
500 kVA	5842 (2650)	5984 (2715)
600 kVA	5998 (2721)	6140 (2786)
750 kVA	7119 (3229)	7261 (3294)
1000 kVA (115 C Rise)	7474 (3397)	7616 (3462)

3.3 Installation Location Considerations

Consider the points below when planning the final location for the Vertiv™ Liebert® PPC Large Power and Distribution Cabinet installation.

- Install the Vertiv Liebert PPC Large Power and Distribution Cabinet close to the loads it is supplying.
- Do not locate the unit over combustible surfaces.
- Employ the shortest output distribution cable runs that are consistent with a logical equipment arrangement and make allowances for future additions.
- **Operating environment:** The Vertiv Liebert PPC Large Power and Distribution Cabinet operates at ambient temperatures of 32 °F to 104 °F (0 °C to 40 °C) with a relative humidity of 0% to 95% (non-condensing).
- Heat output, like any electrical device, the Vertiv Liebert PPC Large Power and Distribution Cabinet produces heat during normal operation. Include the heat output when calculating the environmental conditions of the room. Refer to **Table 3.2** below for approximate heat output.

Table 3.2 Heat Output

Unit Size kVA	Approximate Heat Output BTU/hr (kW)
400	20882 (6.1)
500	31392 (9.2)
600	35827 (10.5)
750	34121 (10)
1000 kVA (115 C Rise)	60,694 (17.8)

Minimum clearances for operation and service required by the National Electrical Code (NEC) Article 110-26:

- The recommended minimum clearance at the top or bottom of the unit for cables/conduit and cooling airflow is 18 in. (475 mm). See Item 1 in **Figure 3.1** below.
- The required minimum service clearance is 42 in. (1067 mm). See Item 2 in **Figure 3.1** below.

Figure 3.1 Clearances for Operation and Service

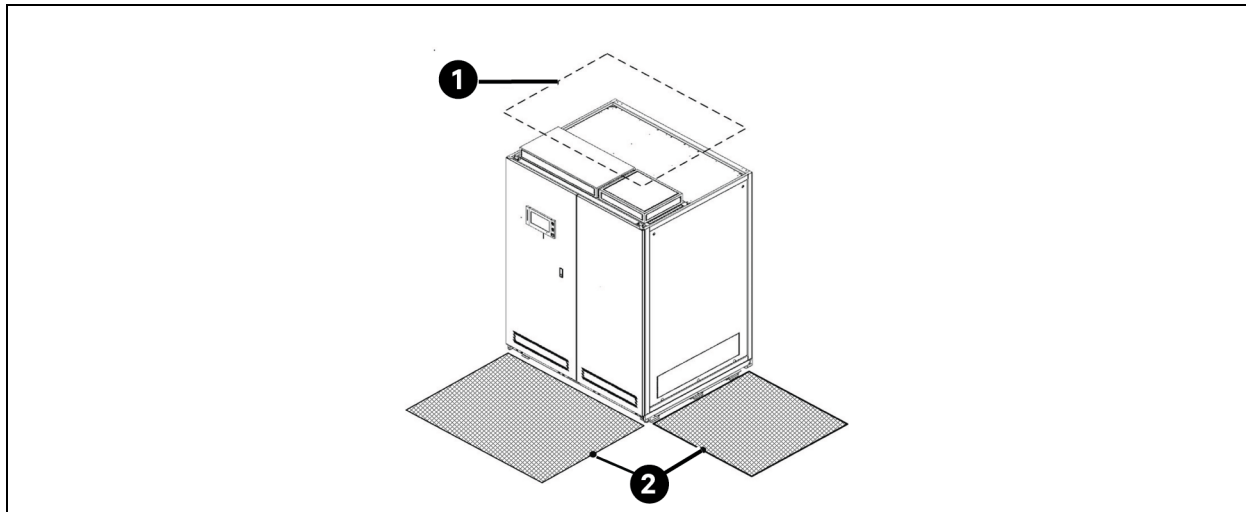

Item	Description
1	Minimum 18 in. (457 mm) clearance recommended above the unit for cooling air flow
2	Minimum 42 in. (1067 mm) clearance recommended at the front and one side of the unit for service access

3.4 Removing the Unit from the Shipping Pallet

Before removing the unit from the pallet, move the unit as close as possible to the final installation location. Refer [Equipment Handling and Moving](#) on page 5.

To remove the unit from the pallet:

1. Set the palletized unit on an open level surface then, cut the shipping bands.



WARNING! Risk of cutting bands under tension. Can cause injury or death. The shipping bands may be under tension. Use appropriate eye, face, and hand protection to safeguard against injury from band backlash.

2. Using the Allen wrench supplied in the installation package, remove the side and rear panels from the unit, and carefully disconnect the panel ground wires by pulling the easy disconnect terminals at the unit frame.
3. Remove the bolts that hold the unit to the pallet. Then remove the shipping brackets from under the unit. Discard the shipping brackets. Do not use the shipping brackets to secure the unit in your facility. The shipping brackets are not designed for cooling and can cause the PDU to overheat.
4. Use a forklift to lift the unit from the pallet and set it on the floor.

NOTE: If the user uses a forklift to move the unit, make sure that the forks extend completely across the unit because the user must use all 3 frame beams on the unit when lifting it with a forklift.

5. Read the advisories in [Installation Location Considerations](#) on the previous page, and follow them when rolling the unit to the installation locations.

This page intentionally left blank

4 Power and Control Wiring Installation

Power and control wiring must be installed by licensed electricians. All power and control wiring must comply with the NEC and applicable local codes. See **Figure 4.1** below for a typical one-line diagram.

NOTE: The number of subfeed breakers varies with the system configuration.

Figure 4.1 Typical One-Line Diagram

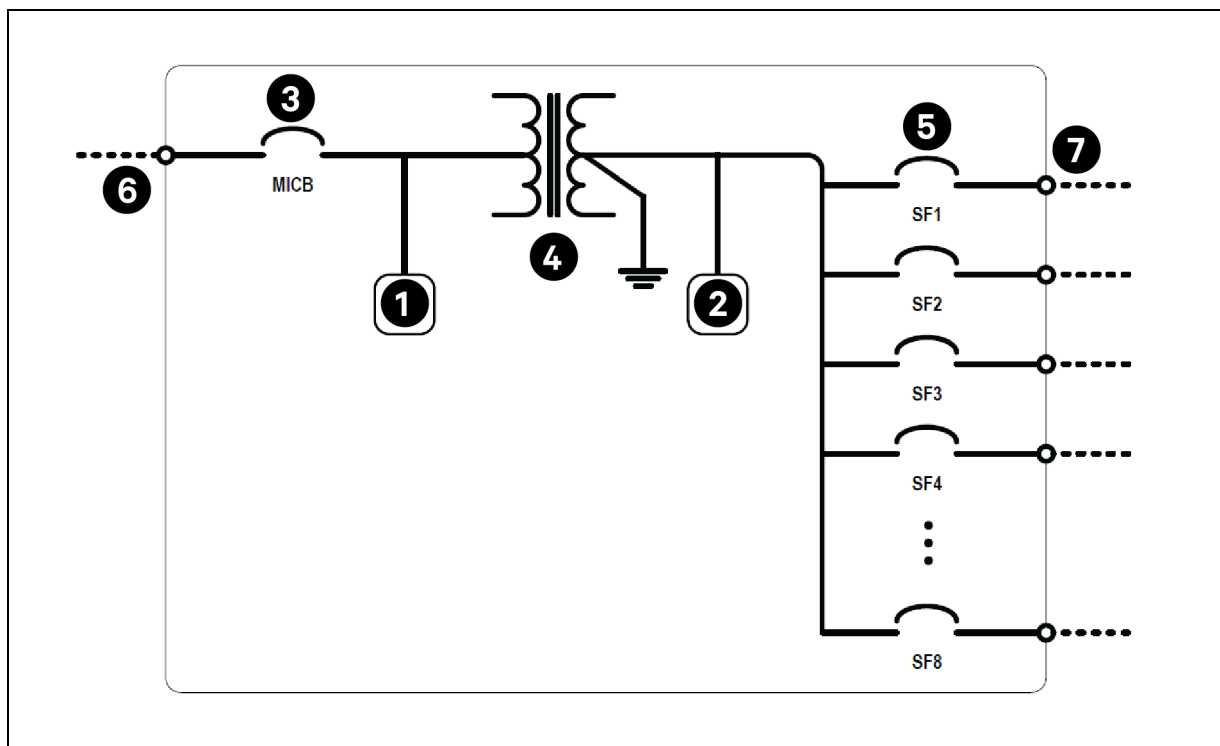

Item	Description
1	Lightning Arrester (Optional)
2	Output spike suppression module (Optional)
3	Main Input Circuit Breaker (MICB)
4	Isolation Transformer
5	Subfeed Circuit Breakers (Up to 8, depending on configuration)
6	Main Input, three-phase, 3 wire + G
7	Subfeed Outputs, three-phase, 4 wire + G

4.1 Input Power Connection



WARNING! Risk of electric shock. Can cause injury or death. Verify that all incoming line voltage (power) and low voltage (control) circuits are de-energized and locked out before installing cables or making connections in the junction box or in the unit.

The input power feeder enters through the top of the unit and routes to the busbars in the front of the unit. To minimize disturbances caused by other loads in the building, supply the three-phase power input to the unit directly from the service entrance or other power source (a dedicated power feeder). Size the input feeder circuit in accordance with the NEC and any local building codes to ensure the feeder can safely carry the full load current of the system, including losses. Size input feeder conductors for no more than 2% voltage drop. To operate at undervoltage conditions for extended periods of time, the input feeders must be oversized. The main input feeder must consist of three-phase conductors and one (safety) ground conductor (3W + G). Reference submittal drawings for the recommended feeder sizes are **PPC-03-S001**, **PPC-03-S002**, and **PPC-03-S003**.

4.2 System Grounding

The performance and safety of any power conditioning system depend on proper grounding. **Figure 4.2** on the facing page shows the typical grounding arrangements for the Vertiv™ Liebert® PPC Large Power and Distribution Cabinet.

Proper grounding is required for safe operation and enhances equipment performance. All power feeders must include the equipment grounding as required by the NEC and local codes. An insulated ground conductor is recommended to be run in each feeder conduit. The minimum size of ground conductors must be as per NEC Table 250-122. For increased system performance, make use of larger wire sizes. To use the input power feeder conduit as a grounding conductor, it is mandatory to maintain adequate electrical continuity at all conduit connections. It is not recommended to use isolating bushings in a metal conduit run.

If the unit supplies power to a computer room, an area equipped with a signal reference grid, or a grounded, raised floor stringer system, connect a grounding conductor from the system ground bus to the grid or floor system. This conductor must be stranded or braided #8 AWG or larger and as short as practical, we recommend less than 3 ft. (1 m).

4.3 Grounding Electrode Conductor

As required by code, the Vertiv Liebert PPC Large Power and Distribution Cabinet must be grounded according to the safety practices of NEC 250.30. We recommend a local grounding electrode conductor in addition to the equipment safety ground that is normally run with the input power conductors.

For electrode connection as shown in **Figure 4.2** on the facing page, the grounding electrode conductor is run from the unit to the nearest effectively grounded below items in order of preference:

- Building steel.
- Metal water pipe.
- Other made grounding electrode.

Sizing of the grounding electrode conductor is based on the secondary circuit conductors as per NEC Table 250.66.

Figure 4.2 Typical PPC Grounding Arrangement

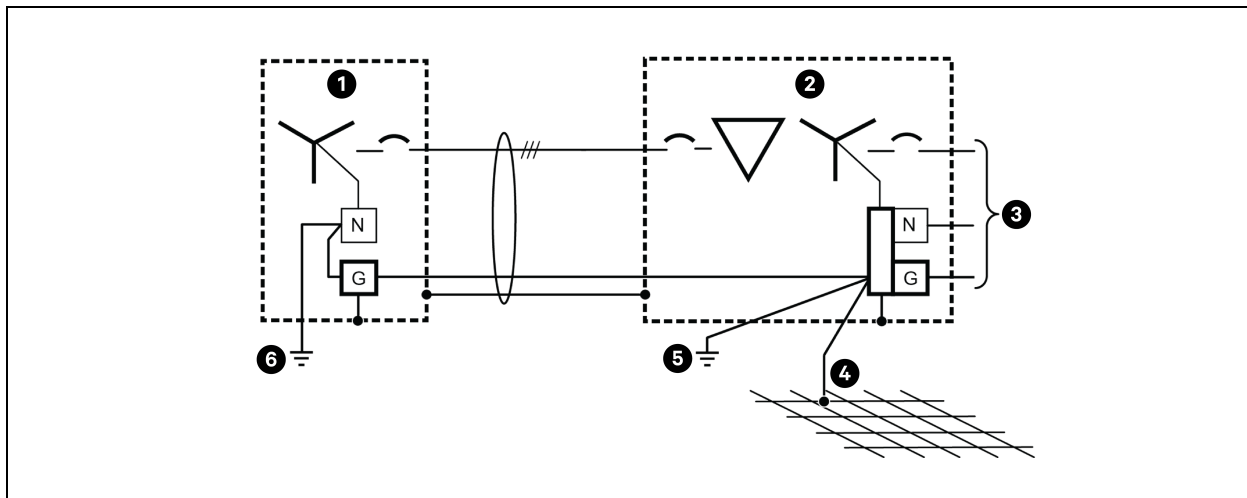

Item	Description
1	Service entrance
2	Vertiv™ Liebert® PPC large power and distribution cabinet unit
3	Output
4	Signal reference grid (if used)
5	Local grounding electrode conductor as per NEC 250.30
6	Service entrance grounding electrode system

Below are the recommended methods for running the grounding electrode conductor, in order of preference for system performance and as acceptable by local and other applicable codes:

- Outside of conduit (where not subject to damage).
- Inside non-metallic conduit.
- Inside non-ferrous conduit.
- Inside ferrous conduit, bonded to the ferrous conduit at both ends, as acceptable by local and other applicable codes.

4.4 Output Power Connection

For best performance, locate the Vertiv Liebert PPC Large Power and Distribution Cabinet as close to the load as practical.

Initial system output loading must be between 50% and 75% of rated capacity to allow for the addition of future loads without immediately investing in another power conditioner. The high partial load efficiency of the unit permits such sizing without imposing an energy use penalty during initial operation.

Keep the load balanced: The balancing of loads is good design practice on any three-phase system. Arrange all additions to the system to preserve balance.

Code compliance: All output cables and connections must comply with the NEC and all other applicable codes.

Padlock off provisions: User must equip all output breakers that are hard-wired to the load equipment with a padlock off accessory for the output circuit breaker. The padlock off accessory is used during lockout and tagging of the circuit breaker for service on the hard-wired load equipment in accordance with OSHA safety rules.

4.5 Control Wiring Connections for DPM

Figure 4.3 External Interface Board Connections (Right Side View)

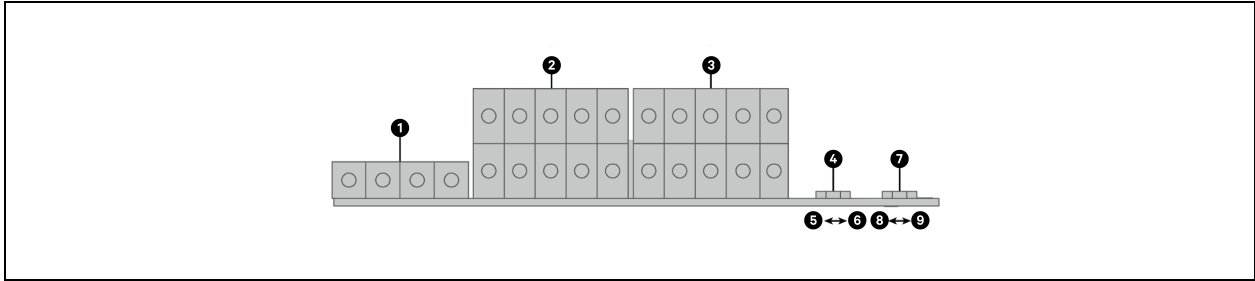

Item	Description
1	TB4, Alarm input, refer to Input Alarm Connections on page 14
2	TB3, output contacts, refer to Output Alarm Connections on page 14
3	TB1, EPO input, refer Emergency Power Off (EPO) Loop below Emergency Power Off (EPO) Loop below
4	Auto/manual restart switch, refer to Auto or Manual Restart Selection on the facing page Auto or Manual Restart Selection on the facing page
5	Enable auto-restart
6	Enable manual restart
7	High temperature shutdown switch, refer to High Temperature Shutdown Selection on page 14 High Temperature Shutdown Selection on page 14
8	Disable high-temperature shutdown
9	Enable high-temperature shutdown

4.5.1 Emergency Power Off (EPO) Loop

The NEC Article 645 requires that EPO switches be located at the principal room exits. All standard Vertiv™ Liebert® PPC units include connections for external shutdown from remote emergency power off (REPO) stations.

The EPO control and logic reside on the transformer monitor board. The EPO system is powered by a 24 VAC control transformer. The 24 VAC is also used to detect loss of system input power.

There are multiple methods of triggering the EPO circuit (shunt trip the MICB):

- Pressing the local *EPO* button next to the touchscreen display on the front of the Vertiv Liebert PPC, which sends a CAN message to the transformer monitor board requesting unit shutdown.
- Pressing the *REPO* button (field provided and field connected to the EPO contacts on the external interface board EPO), which sends a CAN message to the transformer monitor board requesting unit shutdown.
- **Transformer overtemperature:** If the 392 °F (200 °C) transformer thermal switch opens and high temperature shutdown is enabled, a digital input on the transformer monitor board requests unit shutdown.
- **System undervoltage:** If an undervoltage event occurs and manual restart is active, the unit is shut down.

The contact inputs for the remote normally open (NO) and remote normally closed (NC) wire loop connections are on TB1 on the external interface board. See **Figure 4.4** below for the NO and NC loop connections.

- A jumper is factory-installed between TB1-1 and TB1-5 to close the NC loop. Remove the jumper to use the NC EPO loop.
- NO REPO devices may be wired in parallel to the NO REPO contacts.
- NC REPO devices, such as lamps, may be wired in series to the NC REPO contacts.
- Multiple REPO lamps and other 24 VDC loads may be wired in parallel to the REPO lamps.
- The loop provides 24 VDC (nominal) up to 200 mA.

Figure 4.4 EPO Connections to TB1 on External Interface Board

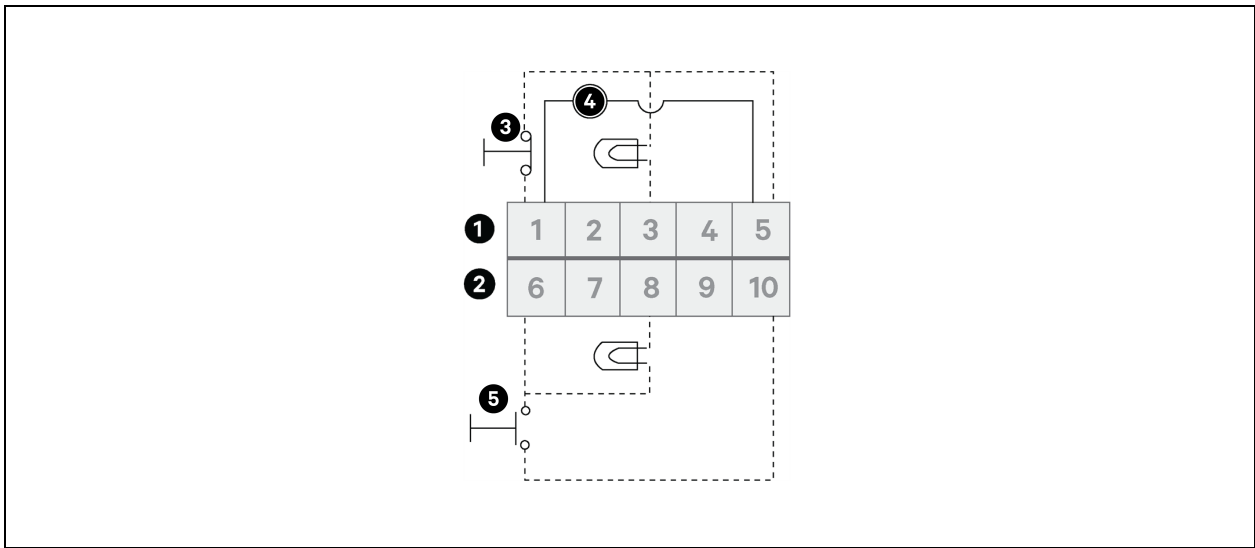

Item	Description
1	TB1 top row
2	TB1 bottom row
3	NC contact
4	Factory-installed jumper. Remove to use the NC EPO loop
5	NO contact

4.5.2 Auto or Manual Restart Selection

Auto/Manual restart controls unit function after loss of input power:

- Auto restart automatically powers the unit back up when input power is restored.
- Manual restart trips the main input circuit breaker (if equipped) and prevents multiple restarts with unstable voltage to allow an orderly system restart.

NOTE: To manually restart the system, refer to [Normal System Startup](#) on page 21.

To select the restart function, set the switch on the external interface board. See **Figure 4.3** on the previous page for the location of the switch.

4.5.3 High Temperature Shutdown Selection

Thermal switches in the Vertiv™ Liebert® PPC transformer provide warning and immediate shutdown. If the unit begins to overheat, high temperature shutdown operates as follows:

- An overtemperature condition occurs when the transformer coil temperature reaches 356 °F (180 °C). A warning displays on the touchscreen controller.
- User must investigate and correct the cause of the warning. Possible causes include excessive non-linear loading, inadequate ventilation, high or low input voltages, or a monitoring system malfunction.
- When the transformer coils reach 392 °F (200 °C) and high temperature shutdown is enabled, the EPO circuit shunt trips the main input breaker, causing an immediate loss of power to the load. If high temperature shutdown is disabled, the unit alarms an overtemperature condition.

NOTE: Equipment damage may occur if high temperature shutdown is disabled and the unit continues to run in overtemperature conditions. Any damage caused by overtemperature conditions when high temperature shutdown is disabled is not covered by warranty.

To select the high temperature shutdown function, set the switch on the external interface board. See **Figure 4.3** on page 12, for the location of the switch.

4.5.4 Input Alarm Connections

When the Vertiv Liebert PPC includes DPM monitoring, two contacts on the external interface board (TB4, see **Figure 4.3** on page 12) provide alarm inputs with 12 VDC wetting voltage. **Figure 4.5** below shows the wiring for the input alarm contacts.

Figure 4.5 Input Contact Wiring on TB4

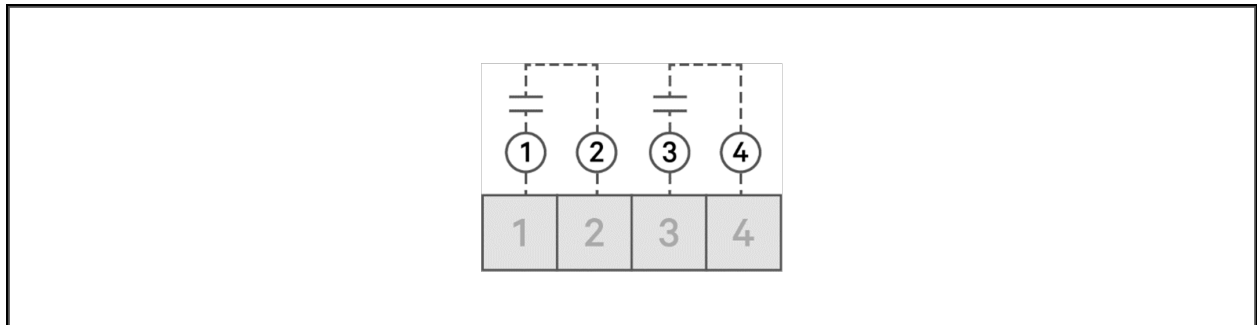

Item	Description
1	Input alarm 1
2	Input 1 common
3	Input alarm 2
4	Input 2 common

4.5.5 Output Alarm Connections

When the Vertiv Liebert PPC includes DPM monitoring, two programmable, form C contacts on the external interface board (TB3, see **Figure 4.3** on page 12) provide output contacts that may be triggered by system events or a summary alarm.

Output contacts are rated for 30 VDC 1 A (30 W maximum resistive) or 125 VAC 0.5 A (62.5 V A maximum resistive). **Figure 4.6** below shows the wiring for the output alarm contacts.

Figure 4.6 Output Contact Wiring on TB3

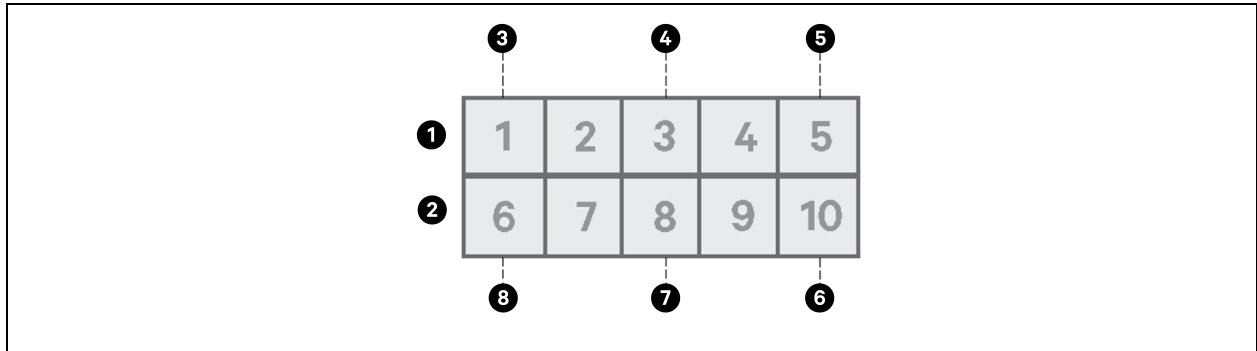

Item	Description
1	TB3 top row
2	TB3 bottom row
3	Customer alarm 1 common
4	Customer alarm 1 NC
5	Customer alarm 1 NO
6	Customer alarm 2 NO
7	Customer alarm 2 NC
8	Customer alarm 2 common

For more information about the DPM connections, refer to the **Vertiv™ Liebert® DPM User Manual SL-11326**.

This page intentionally left blank

5 Equipment Inspection and Startup

Perform the inspection and start-up checks at initial system start-up, each time maintenance/service is performed, and any time the unit is de-energized for an extended period. Print the [Equipment Inspection and Startup Checklist](#) on page 29. Complete the checklist while performing the inspection and start-up procedures.

5.1 Internal Inspection

Perform a detailed internal inspection after the unit is in place and before it is energized to ensure a trouble-free startup. In addition, perform this internal inspection when performing preventive maintenance.



WARNING! Risk of electric shock. Can cause injury or death. Verify that all incoming line voltage (power) and low voltage (control) circuits are de-energized and locked out before installing cables or making connections in the junction box or in the unit.

To perform the inspection:

During initial installation and startup, use a printed copy of the [Equipment Inspection and Startup Checklist](#) on page 29. Perform the steps below to check each item.

1. Confirm that the exterior of the unit is not damaged.
2. Confirm sufficient service and ventilation clearance for the unit, see **Figure 3.1** on page 6.
3. Remove the accessible exterior panels.

NOTE: When removing exterior panels, disconnect panel ground wires by separating the easy disconnect terminals on the frame. When replacing exterior panels, reconnect all panel ground wires.

4. Inspect all wire and conductor insulation for damage.
5. Check all transformer terminal connections for tightness, and torque again if needed, refer **Table 5.1** below.
6. Check all breaker connections for tightness, and torque again if needed, refer to **Table 5.1** below.

Table 5.1 Electrical Connection Torque Requirements

Bolt Shaft Size	Grade 5 - Imperial Grade 8.8 - Metric, in.-lb (nm)	Electrical Connections	
		1 Belleville Washer, in.-lb (nm)	2 Belleville Washers, in.-lb (nm)
10-32 (M5)	25 (3)	—	—
1/4-20 (M6)	53 (6)	40 (4.5)	80 (9)
5/16-18 (M8)	107 (12)	80 (9)	160 (18)
3/8-16 (M10)	192 (22)	120 (13.6)	240 (27.1)
1/2-13 (M12)	428 (48)	480 (54.2)	—

Figure 5.1 Applicable Hardware Configuration for Torque Specifications

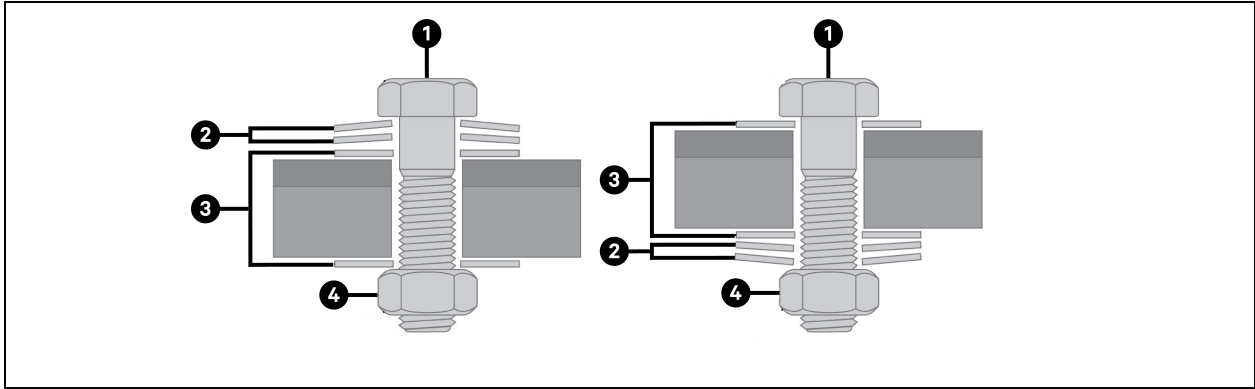

Item	Description
1	Bolt
2	Belleville washer
3	Flat washer
4	Nut

7. Check the trip settings of adjustable breakers.
8. Check all terminal block connections for tightness, and torque again if needed.
9. Check the transformer mounting bolts for tightness, and torque again if needed.
10. Remove the foreign objects from the components and the interior of the unit, and make sure that the air passages on the transformers are clear and free of debris.
11. Check all intake and exhaust air screens, and make sure they are clean and free of obstructions.
12. Replace the side panels, leaving access to the circuit breakers for startup, refer [Unit Startup](#) below.

NOTE: When replacing the side panels, make sure to reconnect the panel ground wires.

5.2 Unit Startup



WARNING! Risk of electric shock. Can cause injury or death. Verify that all incoming line voltage (power) and low voltage (control) circuits are de-energized and locked out before installing cables or making connections in the junction box or in the unit.

To startup the unit:

During initial installation and startup, use a printed copy of the [Equipment Inspection and Startup Checklist](#) on page 29. Perform the steps below to check each item.

1. Make certain that all circuit breakers are in the OFF position and that power to the unit is locked out.
2. Verify proper input power connections to the unit, including the equipment grounding conductor and the local grounding electrode conductor.
3. Turn on the building input power to the unit.
4. Check the phase rotation at the main breaker: A, B, C, top to bottom.

5. Measure the input voltages below, and record them in the appropriate lines on the checklist. Make sure that the measured voltages correspond to the input voltage on the unit nameplate.
 - a. Voltage, phase A to phase B
 - b. Voltage, phase B to phase C
 - c. Voltage, phase C to phase A
6. Turn on the main breaker and wait for 1 minute. If the breaker trips OFF, check for wiring errors, including control connections. Contact Vertiv services or the local Vertiv factory representative for assistance.
7. Check the phase rotation at the load side terminals of the subfeeds: A, B, C, top to bottom.
8. Measure the voltages below at the load side terminals of the output breakers, and record them in the appropriate lines on the checklist. Make sure that the measured voltages correspond to the output voltage on the unit nameplate within +4%, -0%.
 - a. Voltage, phase A to phase B
 - b. Voltage, phase B to phase C
 - c. Voltage, phase C to phase A
 - d. Voltage, phase A to neutral
 - e. Voltage, phase B to neutral
 - f. Voltage, phase C to neutral

If the output voltage is incorrect, check for wiring errors. Incorrect input voltage or improper transformer taps, contact Vertiv services or the local Vertiv factory representative for assistance.

9. Press the local *EPO* button and verify that the system shut down, then turn the unit back ON.
10. If the system is equipped with REPO switches, test each switch to verify proper operation.

NOTE: Any REPO switch may shut down equipment or systems other than the Vertiv™ Liebert® PPC under inspection.

5.3 Monitoring System Check

During initial installation and startup, use a printed copy of the [Equipment Inspection and Startup Checklist](#) on page 29. Perform the steps below to check each item.

1. Turn on building power to the unit, then turn on the main input breaker.
2. Confirm that the power indicator on the local display is illuminated.
3. Confirm manual restart if the unit is configured for manual restart:
 - a. Turn on building power to the unit, then close the main input breaker.
 - b. Turn off all building power to the unit, and observe that the main input breaker automatically trips open when power is lost.
 - c. Restore building power to the unit, and close the main input breaker.
4. At the monitor panel, verify that the voltage values displayed by the graphical human machine interface (GHMI) correspond to the values measured at the main circuit breaker. See step 5 of [Unit Startup](#) on the previous page.
5. If the unit is connected to a centralized monitoring system, turn on the unit and the centralized system, then verify proper communication between the two.
6. Access the low voltage terminals in the low voltage control section inside the unit, with the unit ON, measure the below DC control voltage on +Vout (+) and -Vout (com), and record them in the appropriate lines on the checklist:
 - a. 12 V control voltage (between 11.76 VDC and 12.24 VDC).
 - b. 24 V control voltage (between 23.5 VDC and 24.5 VDC).

7. Simulate alarm operation by referring to the control wiring drawing provided with the unit and jump ring the appropriate low voltage control terminals, then verify correct alarm operation at the local display and the centralized monitoring system, if equipped.

6 Operation

In the mentioned below scenarios, perform the initial inspection and startup procedures detailed in [Equipment Inspection and Startup](#) on page 17; otherwise, use these procedures for standard, day-to-day operation.

- Before the unit is placed into service after initial installation.
- After equipment relocation.
- After the equipment is de-energized for an extended period of time.

Review these guidelines for any special equipment modifications, special site considerations, or company policies that require changes to the standard equipment operation.

6.1 Emergency Shutdown

NOTE: Depending on the control circuit wiring, activating the unit EPO switch may also shutdown other equipment.

To perform an immediate system shutdown during emergency conditions:

1. On the front door of the unit, locate the EPO button on the monitoring panel.
2. Move the protective, clear cover out of the way, and push the button.

– or –

Press a *REPO* switch, if the site is equipped with REPO switches at the principle exit doors as required by NEC Article 645.

6.2 Normal System Shut down

To shut down the system:

1. Shutdown the load equipment by turning off at each piece of equipment per the manufacturer recommendations or at the Vertiv™Liebert® PPC output distribution breakers located behind the front door of the unit.
2. Turn off all unit output breakers, then turn off the main circuit breaker and/or tie circuit breaker.
3. To remove all power from the unit, turn off the building power to the unit.

6.3 Normal System Startup

To startup the system:

1. Locate the unit circuit breakers behind the front door of the unit, and make certain that all unit circuit breakers are in the open position.
2. Turn on the building power to the unit.
3. Close the main circuit breaker of the unit. If the circuit breaker was tripped, move the circuit breaker handle to open before closing it.
4. Verify the output voltages before proceeding to the next step.
5. Close each output circuit breaker individually while following the load equipment manufacturer's startup sequence.

6.4 Manual Restart

If the system includes the manual restart feature, a power outage trips the main circuit breaker, which prevents repetitive application of unstable voltage and allows orderly restart of the system.

To manually restart the system after power is restored, follow the steps in [Normal System Startup](#) on the previous page.

6.5 Vertiv™ Liebert® DPM

The DPM includes a user interface monitor mounted on the front door of the Vertiv™ Liebert® PPC. This monitor contains a color LCD display touchscreen panel, an audible alarm, and an EPO push button.

The monitored parameters and alarms will be displayed on the local display and will be available for communication to a customer or Vertiv monitoring system.

For a detailed description of the functionality and use of the DPM monitoring system, refer to the [Vertiv™ Liebert® DPM User Manual SL-11326](#), which is available at www.vertiv.com.

Figure 6.1 Monitoring Panel Layout

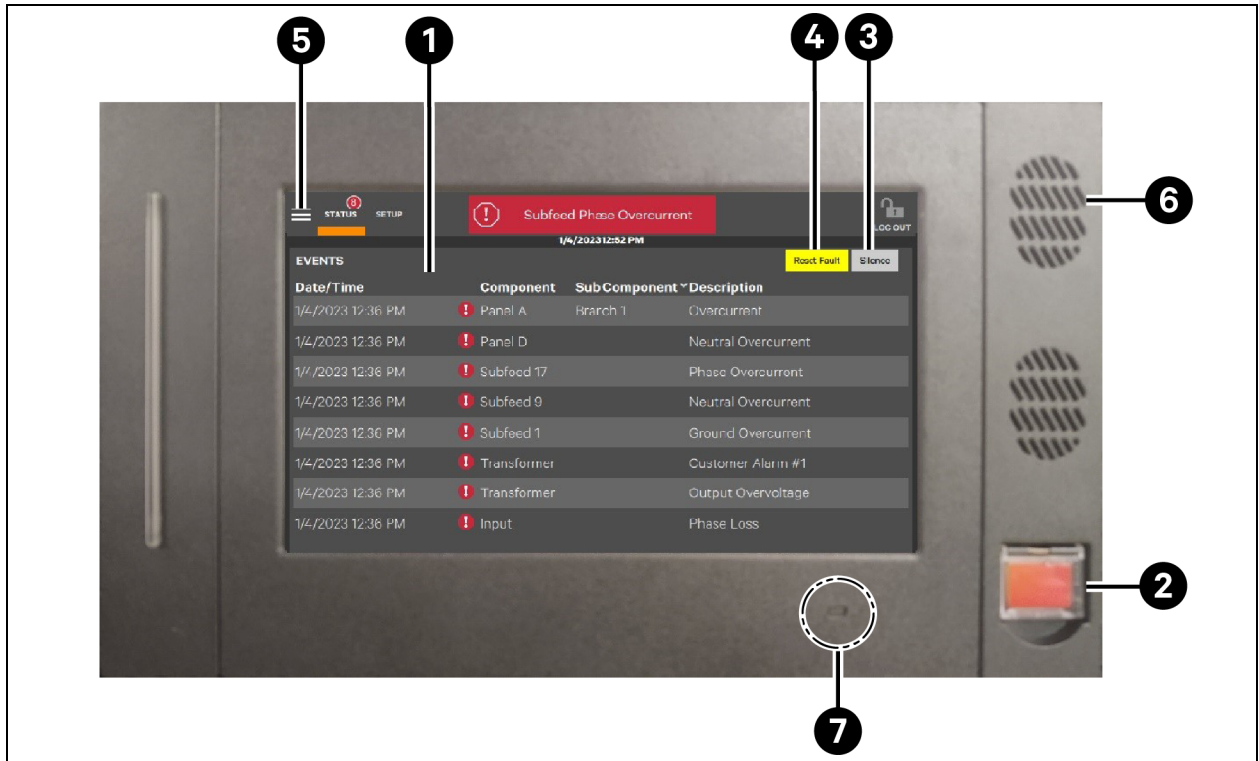

Item	Description
1	LCD displays power parameters and alarm data
2	EPO button trips the input circuit breaker (if supplied) to turn the unit OFF. Refer to Emergency Shutdown on the previous page
3	Silence button silences the audible alarm
4	Reset button to clear alarms and turn off the red alarm status LED. If the alarm condition still exists, the alarm will annunciate again

Item	Description
5	Navigation menu
6	Audible alarm sounds when an alarm condition is detected
7	Alarm status indicator (LED) illuminates RED when an alarm condition is detected and remains RED until the alarm condition is cleared, when no alarm condition exists, the LED illuminates GREEN

6.5.1 Alarms and Alarm Thresholds

Alarms are stored in non-volatile memory to protect against erasure by a power outage.

The user must reset alarms manually after correcting the condition that caused the alarm. Use the Silence/Reset button on the display or, if connected to a remote monitoring system, reset the alarm via the monitoring system. See the Silence/Reset button on **Figure 6.1** on the previous page.

The monitoring system detects and annunciates alarm messages for the conditions below:

- Output Overvoltage.
- Output Undervoltage.
- Output Overcurrent.
- Neutral Overcurrent.
- Ground Overcurrent.
- Output Voltage Distortion.
- Frequency Deviation.
- Phase Sequence Error.
- Phase Loss.
- Transformer Overtemperature.

Table 6.1 below lists the factory default alarm thresholds. To adjust alarm thresholds to match the site requirements, use the VPMP configuration software and the DB-9 setup port.

Table 6.1 Factory Default Alarm Threshold Setpoints

Alarm	Setpoint
Output Overvoltage	Voltage exceeds +6% of nominal
Output Undervoltage	Voltage falls below -13% of nominal
Output Overcurrent	Current exceeds 80% of full load amps
Neutral Overcurrent	Current exceeds 95% of full load amps
Ground Overcurrent	Current exceeds: 5 amps
Output Voltage Distortion	Output voltage THD exceeds 10%
Frequency Deviation	Output frequency exceeds ± 0.5 Hz of nominal

Summary alarm

The summary alarm is activated when any alarm is active and can be used to provide remote alarm status. The DPM can be configured to use a customer output contact as a summary alarm signal (refer to [Output Alarm Connections](#) on page 14).

6.5.2 Metered Parameters

The following metering parameters are displayed on the monitoring system:

- Input Voltage, Line to Line for all three phases.
- Output Voltages, Line to Line for all three phases.
- Output Voltages, Line-to-Neutral for all three phases.
- Output Voltage total harmonic distortion (THD) for all three phases.
- Output Current for all three phases.
- Output Current THD for all three phases.
- Output Current Crest Factor (Peak/RMS) for all three phases.
- Output Current Harmonic K-Factor for all three phases.
- Output Neutral Current.
- System Ground Current.
- Output Frequency.
- Output kVA.
- Output kW.
- Output Power Factor.
- Output kW-Hours.
- Percent Load.
- Date and Time.

6.5.3 Remote Monitoring Communication

The Vertiv™ Liebert® PPC has two slots for communication cards, which accept the Vertiv™ Liebert® IntelliSlot™ RDU101 card. The Vertiv Liebert IntelliSlot RDU101 card provides SNMP monitoring of the Vertiv Liebert PPC across the network and/or building management system.

To install a card:

1. Remove the cover from the control area on the unit. Reference the submittal drawing for the location of the card slots.
2. Remove the cover from the slot, slide the card into the slot, and secure it with two screws.
3. Run the cable through the control conduit plate.

Follow the instructions provided with the Vertiv Liebert IntelliSlot card to configure the card for the power distribution system or any additional equipment for the Vertiv Liebert PPC. The installation/user guides for the cards are available at www.Vertiv.com.

7 Maintenance

7.1 Repair

Even the most reliable equipment may fail. Contact Vertiv services at 1-800-543-2378 for fast repair of the unit and minimum downtime of installation.



WARNING! Risk of electric shock. Can cause injury or death. Verify that all incoming line voltage (power) and low voltage (control) circuits are de-energized and locked out before installing cables or making connections in the junction box or in the unit.

Use standard electrical troubleshooting procedures to isolate problems in the unit. For any questions, Contact Vertiv services.

User can refer the repair or replacement of standard items, such as circuit breakers, fuses, transformers, capacitors, and indicator lights, to a qualified electrician or refer these to Vertiv services.

Refer monitoring system repairs to Vertiv services.

7.2 Preventive Maintenance



WARNING! Risk of electric shock. Can cause injury or death. Verify that all incoming line voltage (power) and low voltage (control) circuits are de-energized and locked out before installing cables or making connections in the junction box or in the unit.

Air circulation through the cabinet may cause dust to accumulate on internal components. Clean internal components as necessary during electrical inspections.

It is recommended to perform the annual general system inspections, cleaning, and operation checks to ensure system performance and long service life.

7.3 Inspection Schedule

It is difficult to prescribe a standard schedule for periodic cleanings, because the conditions vary from site to site. It is recommended to perform the inspections after the first 24 hours, 30 days, and 6 months of operation to help determine a pattern for the inspection schedule.

- Inspect electrical connections and component mountings after the first 24 hours, 30 days, and 6 months of operation. Then conduct inspections per local site procedure or annually at a minimum thereafter.
- Inspect and clean ventilation openings and grilles every 6 months to annually at a minimum.
- Perform a complete inspection and operational check annually. It is recommended to perform the procedures outlined in [Equipment Inspection and Startup](#) on page 17.

Vertiv services offers a complete range of preventive maintenance services including thorough equipment performance checks and calibration of electronics. Call 1-800-543-2378 for details.

7.3.1 Fuse List

Table 7.1 below lists the control power fuses in the unit.

Table 7.1 Fuse List

Fuse	Rating	Function
FU1, FU2	125 A	208 V line to control transformer
FU3, FU4	1 A	VAC line to main power supply and 24 VDC power supply
FU5, FU6	0.6 A	VAC line to current monitoring board

Appendices

Appendix A: Technical Support and Contacts

A.1 Technical Support/Service in the United States

Vertiv Group Corporation

24x7 dispatch of technicians for all products.

1-800-543-2378

Liebert® Thermal Management Products

1-800-543-2778

Liebert® Channel Products

1-800-222-5877

Liebert® AC and DC Power Products

1-800-543-2378

A.2 Locations

United States

Vertiv Headquarters

505 N Cleveland Ave

Westerville, OH, 43082, USA

Europe

Victor-von-Bruns Strasse 21,

8212 Neuhausen am Rheinfall, Switzerland

Asia

Singapore

151 Lorong Chuan, Lobby D #05-04

New Tech Park, Singapore 556741

India

Vertiv Energy Private Limited

Plot No. C 20, Road No. 19

Wagle Industrial Estate, MIDC

Thane (West), Maharashtra 400604, India

China

Vertiv Technology Co., Limited

Floors 1–4 and 6–10,

Building B2, Nanshan I Park

No. 1001 Xueyuan Road, Nanshan District

Shenzhen, Guangdong 518055, China

Appendix B: Equipment Inspection and Startup Checklist

Place a check mark next to each item to complete the steps and record the information as noted in the inspection and start-up procedures.

Record the unit information and the date of inspection.

Table 8.1 Unit Information and Inspection Date

Unit Serial Number:	
Unit Model Number:	
Inspection Date:	

Equipment inspection

Table 8.2 Equipment Inspection

Checked	Item
_____	Unit exterior is not damaged
_____	Service and ventilation clearance are sufficient
_____	Wire and conductor insulation is damage-free
_____	Transformer terminal connections are properly tightened
_____	Breaker connections are properly tightened
_____	Adjustable breaker trip settings are correct
_____	Terminal block connections are properly tightened
_____	Transformer mounting bolts are properly tightened
_____	Foreign objects removed from the unit interior
_____	Transformer air passages are clear and free of debris
_____	Intake/exhaust air screens are clean and obstruction-free

System startup

Table 8.3 System Startup

Checked	Item
_____	All circuit breakers are in the OFF position, and the input power to the unit is locked out
_____	Proper connections to the input power, the equipment grounding conductor, and the local grounding electrode conductor
_____	Phase rotation at the main breaker is A, B, C, top to bottom
_____	<p>Measured input voltages at the main breaker match the unit nameplate input voltage:</p> <ul style="list-style-type: none"> • Voltage, phase A to phase B = _____ • Voltage, phase B to phase C = _____ • Voltage, phase C to phase A = _____
_____	The main breaker does not trip after being turned on

Table 8.3 System Startup (continued)

Checked	Item
_____	Phase rotation at the load side terminals of the subfeeds is A, B, C, top to bottom
_____	<p>Measured output voltages at the load side terminal of the output breakers match the unit nameplate voltage within +4%, -0%:</p> <ul style="list-style-type: none"> • Voltage, phase A to phase B = _____ • Voltage, phase B to phase C = _____ • Voltage, phase C to phase A = _____ • Voltage, phase A to neutral = _____ • Voltage, phase B to neutral = _____ • Voltage, phase C to neutral = _____
_____	Local EPO button shuts down the system
_____	<p>Each REPO switch, if equipped, shuts down the system</p> <p>NOTE: Any REPO switch may shut down equipment or systems other than the Vertiv™ Liebert® PPC under inspection.</p>

Monitoring system (if applicable)

Table 8.4 Monitoring System (if applicable)

Checked	Item
_____	Touchscreen display powers ON
_____	Auto/Manual restart function is correct
_____	Input alarm operation correct (if applicable)
_____	BMS communication correct (if applicable)

Connect with Vertiv on Social Media



<https://www.facebook.com/vertiv/>



<https://www.instagram.com/vertiv/>



<https://www.linkedin.com/company/vertiv/>



<https://www.x.com/Vertiv/>



Vertiv.com | Vertiv Headquarters, 505 N Cleveland Ave, Westerville, OH 43082 USA

©2026 Vertiv Group Corp. All rights reserved. Vertiv™ and the Vertiv logo are trademarks or registered trademarks of Vertiv Group Corp. All other names and logos referred to are trade names, trademarks or registered trademarks of their respective owners. While every precaution has been taken to ensure accuracy and completeness here, Vertiv Group Corp. assumes no responsibility, and disclaims all liability, for damages resulting from use of this information or for any errors or omissions.

SL-20050_REVC_05-26