



Liebert[®] TW

Thermal Wall - TW 200/400 Model

User Manual

English, 265867MAN_ENG, rev. H - 15.03.2024
This document, written in English, is the original version

SAVE THESE INSTRUCTIONS

Contents

1. Safety	1	8. Handling	29
1.1 Conventions	1	8.1 Safety Instructions	29
1.2 General Instructions	1	8.2 Inspection	29
1.3 Personal Protective Equipment	2	8.3 Storage	29
1.4 Residual Risks	2	8.4 Transport with Package	30
2. Digit Nomenclature	5	8.5 Unpacking	31
3. Intended Use	7	8.6 Handling without Package	32
3.1 Purpose of the Unit	7	9. Assembly	35
3.2 Assembly	7	9.1 Safety Instructions	35
3.3 Environment	7	9.2 Overview	35
3.4 Space Limits	7	9.3 Assembling the Unit	36
3.5 Operating Conditions	8	9.4 Rearranging the Modules	40
3.6 Storage	8	10. Connections	47
4. Reference Norms	9	10.1 Safety Instructions	47
5. Description	11	10.2 Water System	48
5.1 Overview	11	10.3 Electric Power Supply	49
5.2 Main Components	13	10.4 User Interface and Network Connection	50
5.3 Electric and Control System	15	10.5 Connecting the Differential Pressure Sensor	50
5.4 User Interface and Network Connection	17	10.6 4-20mA Connections	52
5.5 Sensors	17	10.7 Final Checks	53
5.6 Modbus Connections	18	11. Operation	55
5.7 Control System	18	11.1 Safety Instructions	55
6. Technical Data	19	11.2 Power-up	55
6.1 Dimensions and Weight	19	11.3 Start and Stop	56
6.2 Control System	20	11.4 Disconnection from the Power Supply	56
6.3 Air System	20	12. Maintenance	59
6.4 Water System	20	12.1 Safety Instructions	59
6.5 Noise Level	21	12.2 Maintenance Program	60
7. Installation Specifications	23	12.3 Replacement of Components	61
7.1 Site Specifications	23	12.4 Troubleshooting	62
7.2 Site Preparation	24	13. Dismantling the Unit	63
7.3 Water Supply Specifications	25	13.1 Safety Instructions	63
7.4 Water System Preparation	25	13.2 Operations	63
7.5 Electric System Specifications	26	14. Seismic application	65
7.6 Electric System Preparation	27	14.1 Thermal Wall TW 200-400	65

Annexes

Annex A - Installation Drawings	A1
--	-----------

Documents supplied with the machine

- User Manual (this document)
- iCOM™ User Manual
- Electric Diagrams
- Instruction Leaflet for Transport and Handling (on the packaging)
- Labels with Gravity Center (on the packaging)
- Warranty Certificate

1. Safety

Content of this chapter

1.1 Conventions.....	1	1.3 Personal Protective Equipment	2
1.2 General Instructions	1	1.4 Residual Risks.....	2

This chapter gives general safety instructions.
 Additional safety warnings, for specific operations, are given in the rest of the manual.

1.1 Conventions



DANGER

Indicates a hazardous situation which, if not avoided, **will** result in death or serious injury.



WARNING

Indicates a hazardous situation which, if not avoided, **could** result in death or serious injury.



CAUTION

Indicates a hazardous situation which, if not avoided, **may** result in minor or moderate injury



NOTICE

Indicates a property damage message



ENVIRONMENT

Indicates a environment damage message

1.2 General Instructions

Intended readers	<ul style="list-style-type: none"> • This User Manual is intended for transport, installation and maintenance personnel. • The end user can only modify the unit set point.
Personnel	<ul style="list-style-type: none"> • The operations described in this manual must be made by technical staff, expressly authorized in compliance with the regulations in force at the installation site. • The authorized personnel must be properly trained and qualified, wear appropriate personal protective equipment and use adequate equipment and tools.
Read this manual	<ul style="list-style-type: none"> • Carefully read the manual before performing any operation on the unit.
Keep this manual	<ul style="list-style-type: none"> • Keep the manual during the complete life-span of the unit. • Keep the diagrams provided with the unit. They are part of the instructions for use. • If you move or sell the unit, transfer the manual and the diagrams together with the unit. • The manuals may be subject to modification. For complete and up-to-date information always consult the specific manual supplied with the unit.
Intended use	<ul style="list-style-type: none"> • Use the unit only for the purpose it has been designed (see chapter 3. <i>Intended Use</i>). • The manufacturer takes no liability for any improper use of the unit.
Do not modify the unit	<ul style="list-style-type: none"> • Do not modify the unit in any way, including the safety devices, the control system and the software. • The manufacturer takes no liability for any unauthorized modification of the unit.
Warning labels	<ul style="list-style-type: none"> • Pay attention to the warning labels on the unit. • Do not remove or cover the labels placed on the unit by the manufacturer.

Lockout-Tagout (LOTO)

Before any intervention on the electric system or accessing the inner components:

- Lock the disconnection device by a padlock or similar tool.
- Apply on the general disconnecting switch a warning label.

Safeguards

When you finish the operations on the unit, always remind the following:

- Mount again and fix with screws all the safeguards (panels, grids).
- Close and lock all the doors, if present.
- Never operate the unit without the above mentioned safeguards.

1.3 Personal Protective Equipment

As a general rule, always wear the following PPE (Personal Protective Equipment):



1.4 Residual Risks

Some operations may involve some residual risk.

Pay attention to the following safety measures when operating inside or near the unit.



Electric and control system

Open the disconnecting switch(es) as explained in this manual, to cut off the power supply before maintenance or set-up operations on or near the unit.

Pay attention to the power supply cable(s) and components that are still energized after that the disconnecting switch(es) are opened.



Electric and control system

The unit contains potentially lethal voltage in some circuits.

The electric and control panels can retain a stored high-voltage electrical charge for up to **10** minutes.

Risk of arc flash and electric shock.

Can cause injury or death.

General safety measures:

- Only properly trained and qualified personnel may perform repair, maintenance and cleaning.
- Always wear the protective equipment prescribed by the local regulations.
- It is forbidden to operate on the electrical components without using insulating platforms, or in the presence of water and humidity.

Before working inside the electric and control panels proceed as follows:

1. Open all the local and remote disconnecting switches of the unit.
2. Wait at least **10** minutes.
3. Verify with a voltmeter that the power is **OFF**.



Electric and control system

The disconnecting switch on the control panel does not cut off the power to the fans.

Each fan is directly connected to the power supply line and has its own disconnecting switch.



Sharp elements

The heat exchangers are made of plates and fins, which may have sharp edges.

Also other elements inside the unit may have sharp edges, splinters and exposed fasteners.

General safety measures:

- Always wear cut resistant gloves.



**Automatic start-up
+ rotating elements**

This unit operates and restarts automatically.

The fan blades can automatically start rotating without warning at any time during a cooling cycle or when the power is restored after a power failure.

Risk of contact with high-speed, rotating fan blades.

Can cause serious personal injury or death.

Before working inside the unit, removing the fan guards or servicing the fans (speed control, blades, motors) proceed as follows:

- Open all the disconnecting switches.



Lifting and moving

- Make sure to use transport and lifting equipment rated for the unit dimensions and weight.

- Pay attention to the gravity center and warning labels placed on the unit.

- Make sure that the lifting point is aligned with the gravity center.



Handling area

- Never walk or stay below a suspended load.

- The area for handling and moving must be free from obstacles and persons.

- Not authorized personnel must keep at safe distance from the handling area.

- The floor of the handling area must be suitable to bear the weight of the unit and of the moving equipment.

2. Digit Nomenclature

Available models

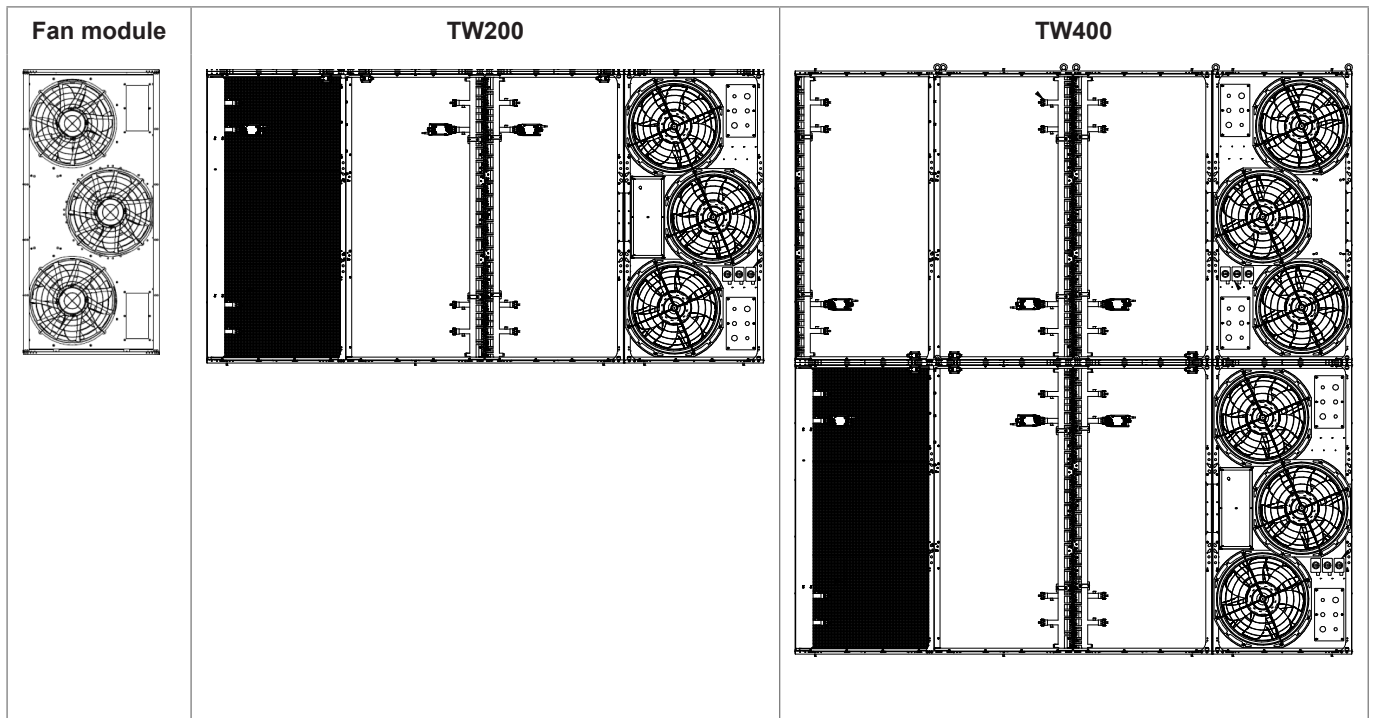

Digits

The unit is fully defined by the following digits.

1	2	3	4	5	6	7	8	9	10	11	12
T	W	0	0	0							

Dig.	Feature	Value	Description	Model	
				TW200	TW400
1 2	Family name	TW	---		
3 4 5	Model	000	---		
6	Basic unit (external unit not included)	M	Only master		Not available
		C	Complete unit	Not available	
7	Fan position	1	Right		
		2	Middle-right		
		3	Middle-left		
		4	Left		
8	CW valve	S	Standard 2-way valve		
		P	PICV		
9	Power supply	3	400 V / 3 ph / 50 Hz + N		
		1			
10	Fans	1	Standard		
11	Coil type	C	Al-Cu		
12	Packaging	M	Only master standard		
		S	Complete unit standard		
		V	Only master seaworthy		
		W	Complete unit seaworthy		

3. Intended Use

Content of this chapter

3.1 Purpose of the Unit.....	7	3.4 Space Limits.....	7
3.2 Assembly.....	7	3.5 Operating Conditions.....	8
3.3 Environment.....	7	3.6 Storage.....	8

3.1 Purpose of the Unit

The **Liebert® TW Thermal Wall** units have been designed and manufactured for the following purpose:

- Air cooling by chilled water heat exchangers, inside a building.

3.2 Assembly

The **TW200** units are made in one section, the **TW400** units are made in two sections.

Each section is factory assembled, including all the internal wiring.

The only operation to be made at the installation site are the following:

- Mounting and assembling together the two sections
- Electric connections for power supply
- Water system connections



WARNING

Do not assemble or connect the unit with systems or machines that are different from what is specified in this manual for your unit. Contact Vertiv™ in case of doubt.

3.3 Environment

The unit is designed for indoor installation, protected from weather agents.

The unit must be installed in a closed environment that has been prepared with walls and channels as explained in this manual.

Do not install the unit in an open space or outdoors.



WARNING

Do not use in explosive, acid or anyway aggressive atmosphere.

3.4 Space Limits

Overall unit dimensions Provide enough free space to place the unit. See chapter *6.1 Dimensions and Weight*

Clearance Keep a free space around the unit as explained in chapter *7.1 Site Specifications*.

3.5 Operating Conditions

Air returning to the unit inlet

Temperature +20°C — +50°C



NOTICE

The unit is not designed to recover condensate from chilled water coils.

Cooling water

Temperature +15°C — +30°C

Pressure maximum 10 bar

Differential pressure, water valve maximum 350 kPa

Chemical and physical characteristics See chapter 7.3 *Water Supply Specifications*

Altitude Electrical equipment shall be capable of operating correctly at altitudes up to 1 000 m above mean sea level

3.6 Storage

Position Keep the unit vertically upright.

Storage environment Indoor environment, protected against weather agents
Clean (no dust), well-ventilated, non-condensing

Ambient temperature -20°C – +50°C

Ambient humidity <90% and preventing surface condensation

Humidity adsorber Install the dessicant in horizontal position. Replace the dessicant each month during the storage time.

Storage time The total storage time should not exceed **six** months.
If the storage time is longer than **six** months, then you must check the functionality of sensors and other electronic devices before putting in operation the unit.

4. Reference Norms

The **Liebert® TW Thermal Wall** units are designed, manufactured and tested according to the following directives and standards:

- EU Directives**
- Machinery Directive 2006/42/CE;
 - PED Directive 2014/68/EU;
 - Low Voltage Directive 2014/35/UE;
 - EMC Directive 2014/30/UE;
 - RoHS II Directive 2011/65/EU;
 - RoHS III Directive EU/2015/863.

CE Marking and Conformity Declaration

The units are marked "**CE**".
 Each unit is supplied complete with individual test certificate and a certificate of conformity to the European Union Directives.
 See also the last page.



UKCA Marking and Conformity Declaration

The units are marked "**UKCA**".
 Each unit is supplied complete with individual test certificate and a certificate of conformity to the UK Safety Regulations.



Performance test norms

- Cooling Capacity according to EN 14511;
- Sound Power Level according to ISO 3744.

5. Description

Content of this chapter

5.1 Overview.....	11	5.4 User Interface and Network Connection.....	17
5.1.1 Structure.....	11	5.5 Sensors.....	17
5.1.2 Operating principle.....	12	5.5.1 Sensors mounted on the unit.....	17
5.1.3 Building layout.....	13	5.5.2 Remote sensors.....	18
5.2 Main Components.....	13	5.6 Modbus Connections.....	18
5.2.1 Fan modules - air system.....	13	5.7 Control System.....	18
5.2.2 Coil modules - water system.....	14		
5.3 Electric and Control System.....	15		
5.3.1 Power supply.....	15		
5.3.2 Fans power connections.....	15		
5.3.3 Control panel.....	16		

NOTE The images in this manual refer to sample units. Some components may be different for other units but the function remains the same.

5.1 Overview

5.1.1 Structure

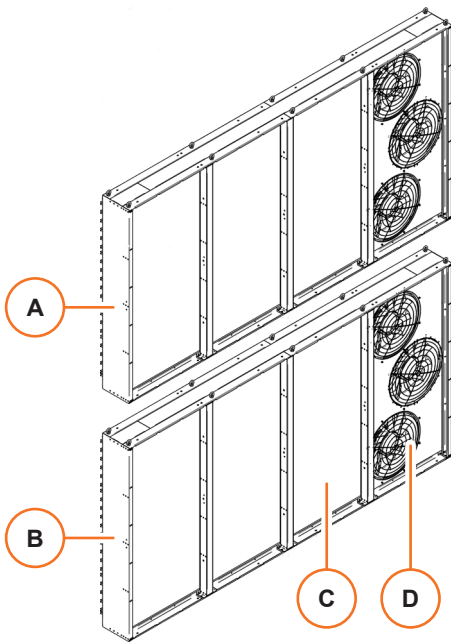

- A** Upper section
- B** Lower section
- C** Coil module
- D** Fan module

Each section is factory assembled, including all the internal wiring.

The upper section [A] is mounted on top of the lower section [B] at the installation.

Each section is made of four modules: three coil modules [C] and one fan module [D].

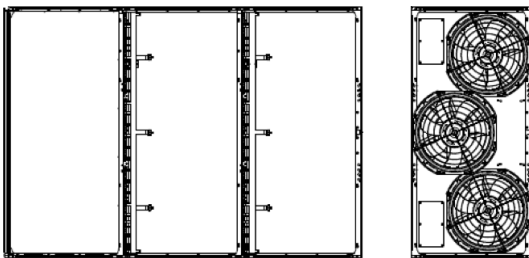

Each section is delivered already assembled (coil module + fan module). However, the fan module can be detached from the coil module, so it is possible to change the position of the fan modules depending on the building layout.

NOTE Each module in the lower section must be matched with a module of the same type in the upper section: fan module with fan module, coil module with coil module.

5.1.2 Operating principle

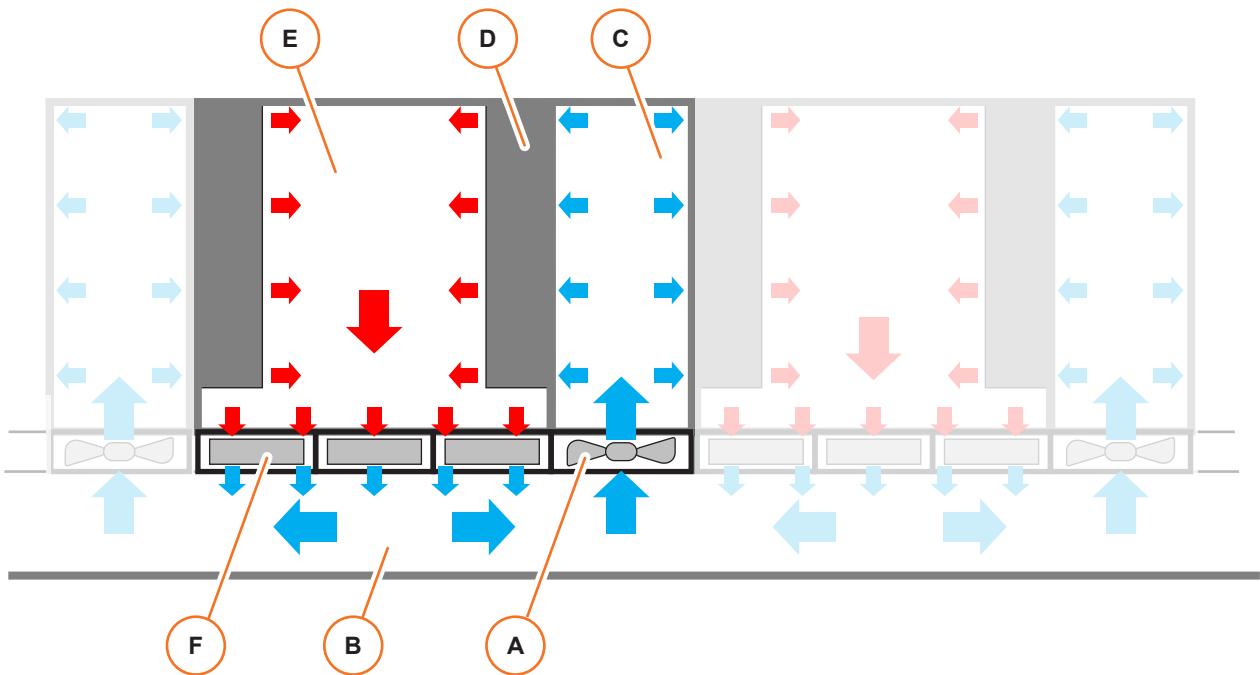

The fan [A] takes in the **cold air** from the corridor [B] and blows the **cold air** into the enclosed space [C].

The equipment to be cooled [D] takes in the **cold air** and returns the **warm air** into the enclosed room [E].

The air flows through the coils [F] thanks to the low pressure in the corridor, created by the fans.

Cold water flows in the coils and cools down the air that returns to the fans.

Several units are placed one after the other to create a continuous wall.

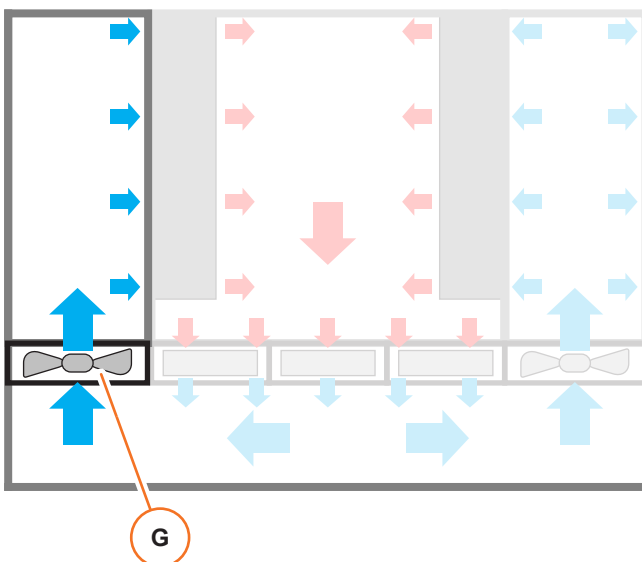

Separate fan modules [G] can be supplied on request to match special requirements. Please contact Vertiv™ for details.

5.1.3 Building layout

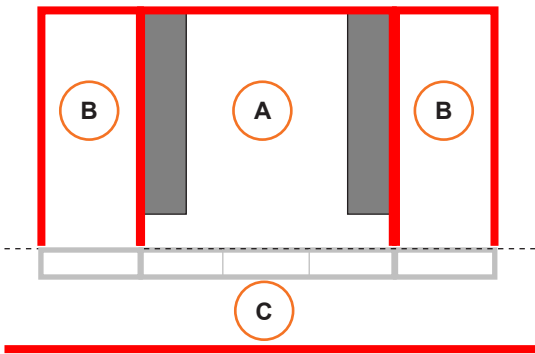

The building must be prepared with walls that separate the following zones:

- A** Room with the equipment to be cooled
- B** Cold air zone
- C** Corridor

NOTE The access to the unit for maintenance and replacement of components is only from the corridor.

5.2 Main Components

5.2.1 Fan modules - air system

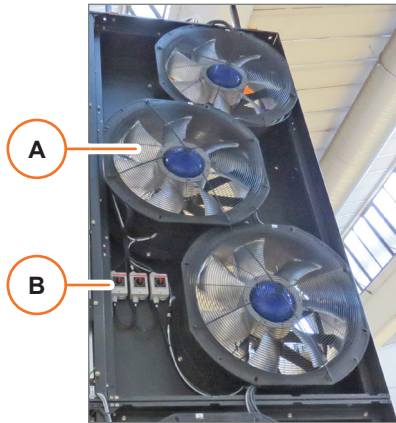

- A** Fans
- B** Disconnecting switches for the upper fans (one for each fan)
- C** Disconnecting switches for the lower fans (one for each fan)



- D** ATS Electrical panel

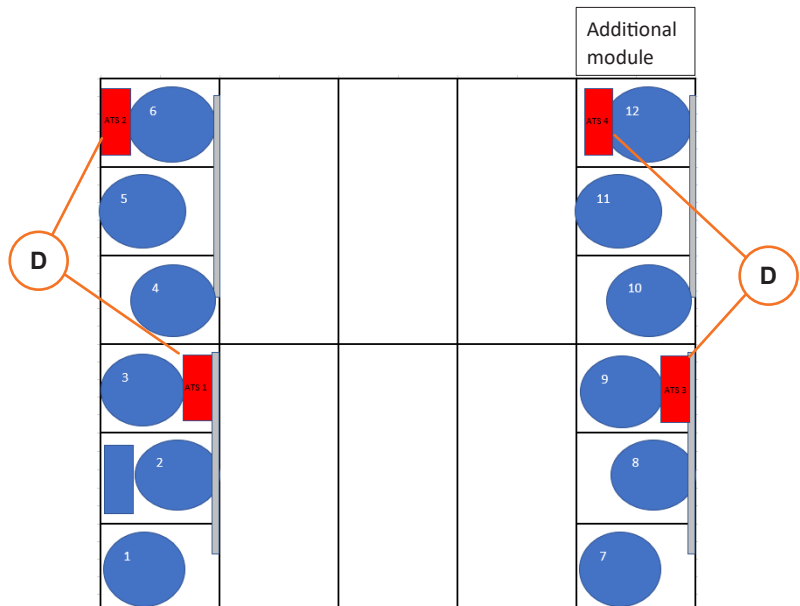

5.2.2 Coil modules - water system

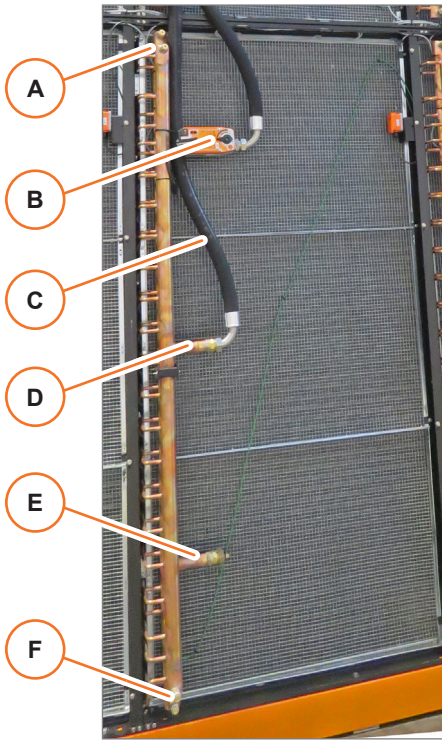

- A Vent valve

- B Two-way servo valve at water inlet

- C Flexible piping

- D Outlet connector

- E Additional inlet connector

- F Drain valve

NOTE You can use either the outlet [D] or the outlet [E] depending on the position of the water manifolds in the building.

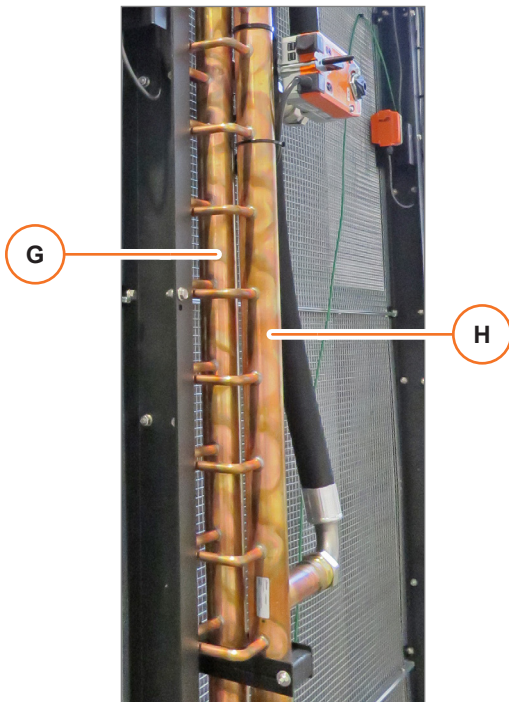

- G Inlet manifold

- H Outlet manifold

5.3 Electric and Control System

5.3.1 Power supply

With ATS configuration, each unit has two independent power supplies.

Each unit has seven independent power supplies:

- six three-phase power supply for the fans
- one single-phase power supply for the control system (sensors, valves, ...)

See 6. *Technical Data* for the power supply relevant data and limits (voltage, frequency, ...).

Make reference to the *Electric Diagrams* for details.

The protective conductor has a cross-sectional area of at least 10 mm² Cu or 16 mm² Al.

AC supplies specifications

Supply Voltage: 400V/3ph/50Hz + N + PE

Harmonics: not exceeding 12% of the total r.m.s.

Voltage interruption: interrupted or at zero voltage for not more than 3ms at any random time in the supply cycle with more than 1s between successive interruptions.

Voltage dips not exceeding 20% of the r.m.s. voltage of the supply for more than one cycle with more than 1s between successive dips.

5.3.2 Fans power connections

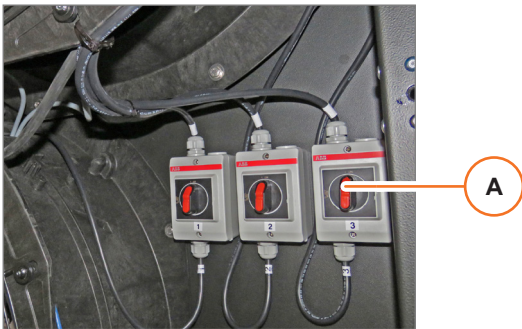

- A** Disconnecting switches (one for each fan) or Circuit breaker for ATS configuration



WARNING

Each disconnecting switch [A] cuts off the power of the related fan only. The other fans and the control system remain connected to the power supply

NOTE *The fans have their own control system. Make reference to the fans manufacturer documentation for details.*

5.3.3 Control panel

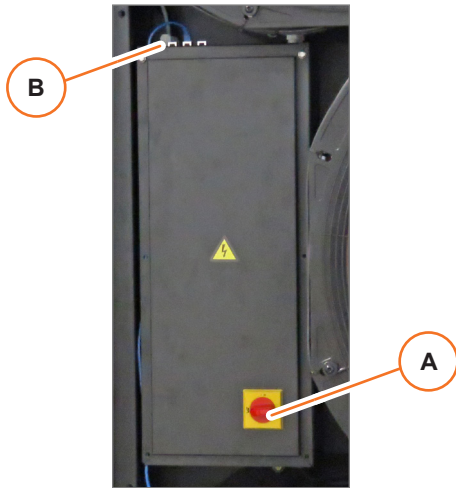

A Disconnecting switch

B Network ports



WARNING

The disconnecting switch [A] cuts off the power to the control system, but it does not cut off the power to the fans.

NOTE The cover of the control panel can be opened only by the proper tool.

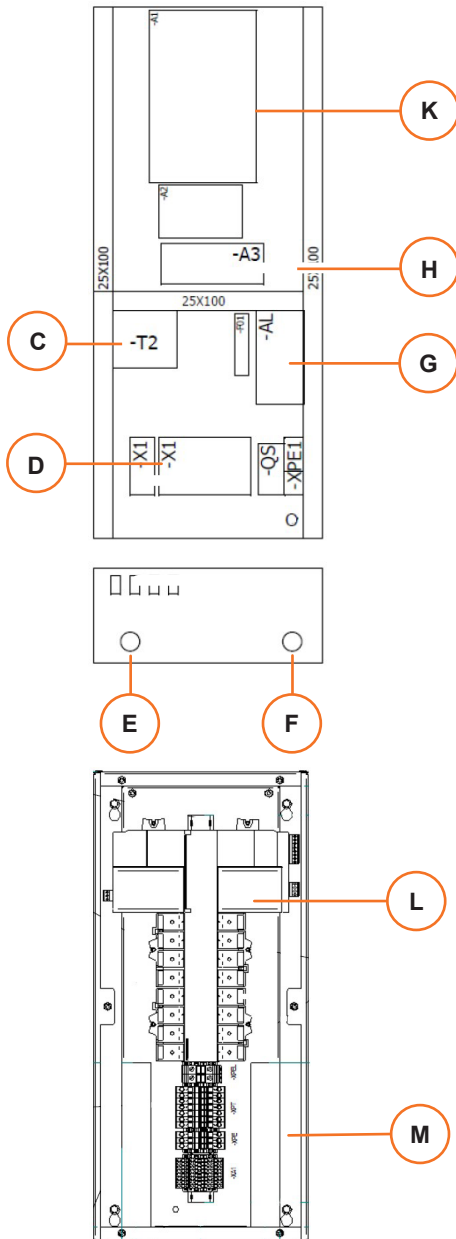

C Transformer

D Terminal block for remote sensors

E Inlet for sensors cables

F Inlet for power supply cable

G Power supply for remote sensors

H Ethernet switch

K Control panel

L ATS

M Terminal block

5.4 User Interface and Network Connection

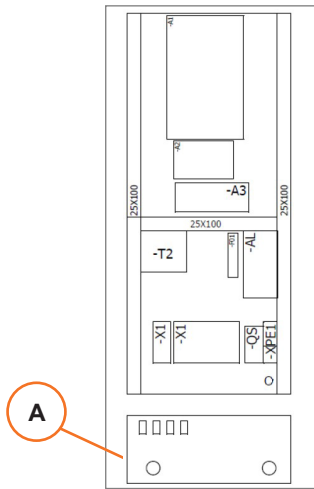

A Network ports

Use the network ports for the following connections:

- laptop to access the unit configuration and diagnostic interface (iCOM™)
- network with the other units of the same room or building

The units of the same room or building share the same set point.

See the *iCOM™ User Manual* for details.

5.5 Sensors

5.5.1 Sensors mounted on the unit

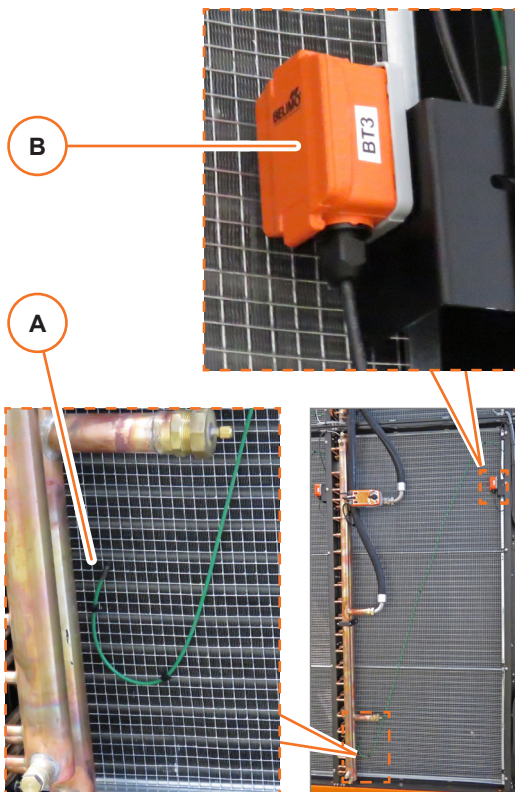

A Temperature probe

B Temperature probe terminal board

Function

Measurement of the air temperature at the cold side of the coil

5.5.2 Remote sensors

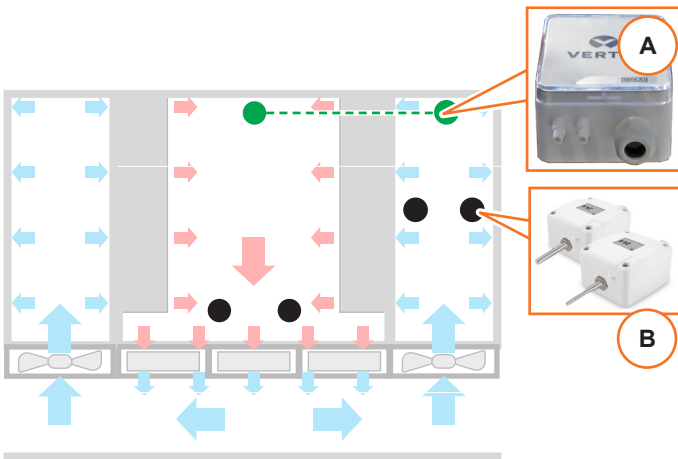

Differential pressure sensor

Function

- A** Measurement of the pressure difference between the cold and the warm side.
The two pressure probes ● must be placed at the far end of the room, one on each side of the equipment to be cooled.

Humidity and temperature sensors

Function

- B** Measurement of the air temperature and humidity in the cold zone and in the warm zone
Two probes ● must be placed in the cold zone, other two probes must be placed in the warm room.

5.6 Modbus Connections

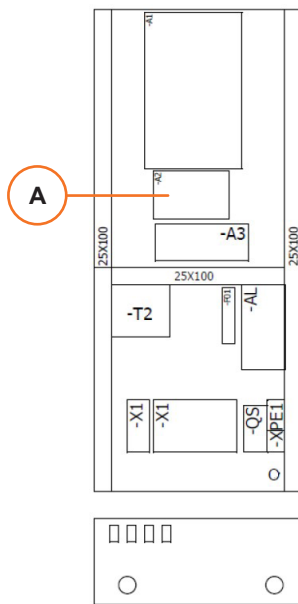

A Terminals for Modbus connections

- The line connects the devices that are mounted inside the unit (coils water valves, fans). These devices are already connected by the manufacturer.

NOTE This Modbus cable also supply power to the coils temperature sensors and to the coils water valves (which are connected on the first part of the cable). The fans have their own power supply.

See the *iCOM™ User Manual* for details.

5.7 Control System

The units of the same room or building share the same set point.

The control system of each unit adjusts the following operating parameters:

- Speed of the fans, depending on the air temperature difference between cold and warm side, measured by the remote sensors.
- Opening of the water servo valve of each coil, depending on the air temperature measured by the sensor mounted at the cold side of the coil.

Special conditions:

- If the pressure difference between the cold and the warm side is too low, it means that the fan speed is too low. Then the control system switches from air temperature control to pressure control: the fan speed is adjusted so to have at least a preset minimum pressure difference (and therefore air flow) between the two sides, even at the far end of the room.
- The fans continue to run at a preset speed if the Modbus connection is interrupted.
- The water servo valves open completely if the Modbus connection is interrupted, or in case of power failure.

6. Technical Data

Content of this chapter

6.1 Dimensions and Weight.....	19	6.4 Water System.....	20
6.2 Control System.....	20	6.5 Noise Level.....	21
6.3 Air System.....	20		

6.1 Dimensions and Weight

Dimensions [mm]

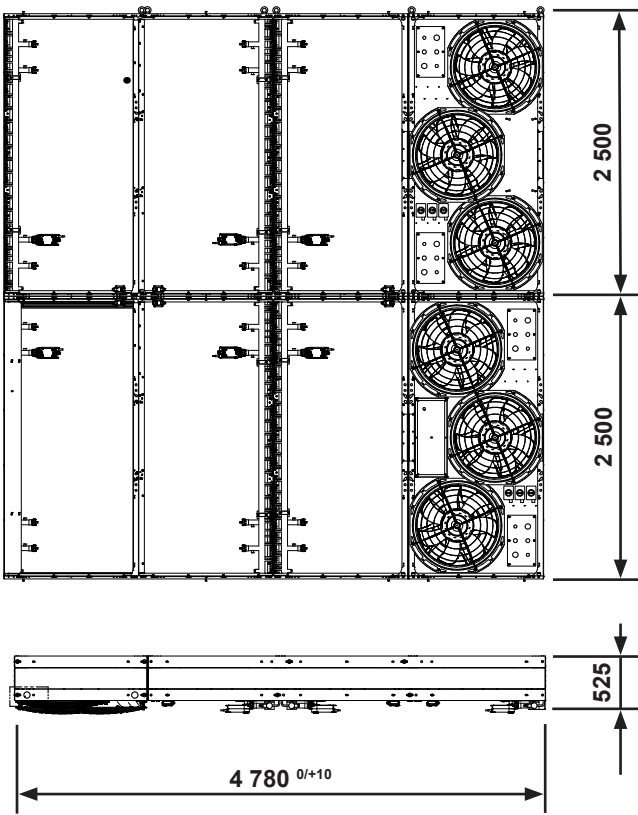

Gross weight (unit packaged in wooden box)

See the packaging documents.

Net weight

- lower section: 1 400 kg
- upper section: 1 400 kg
- total: 2 800 kg

Gravity centers

Make reference to the marks on the unit sections.

Dimensions [mm]

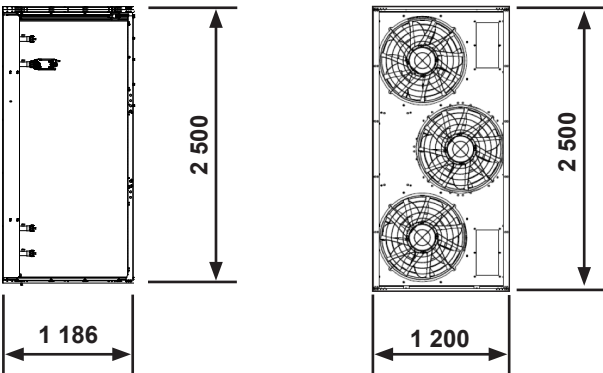

Weight of the main components

- fan module: 400 kg
- coil: 170 kg (each single one)
- each single fan: 36,40 kg

6.2 Control System

Communication protocol	Modbus
Sensors	Coils temperature sensors BELIMO 22MT-544 Remote air temperature sensor TITEC AUTFext Pressure sensor WIKAA2G-50
Reference documentation	<i>Electric Diagrams</i> provided with the unit <i>iCOM™ User Manual</i> Sensors manufacturer documentation

6.3 Air System

CW fans	Quantity	6
	Type	Axial 710 mm ZN071-ZIL-GL.V7P4
	Power supply	400 V - 3 ph - 50 Hz
	Maximum power input	6 x 3,2 kW
	Maximum operating Ampere	6 x 5,2 A
	Fan weight	36,40 kg

6.4 Water System

CW coils	Quantity	6
	Type	Aluminum fins and copper tubes
Valve type (Standard 2-way valve)	BELIMO R2040-16-S3 2-way with internal thread Pipe connectors Internal thread in accordance with ISO 7/1	
Actuator (Standard 2-way valve)	BELIMO SRF24A-MOD-0 Rotary actuator with emergency control function	
Valve type (PICV)	BELIMO EP050R + MOD 2" (Actuator included) 2-way with internal thread Pipe connectors Internal thread in accordance with ISO 7/1	
Connections type	G 1.1/2" ISO 228/1	
Water supply specifications	See chapter <i>7.3 Water Supply Specifications</i>	

6.5 Noise Level

The tables show the noise data for the unit operating continuously at full load at the following conditions:

Table 01 - Sound Power Level [dB]

Model	Octave Band Frequency								Total PWL [dB(A)]
	63 Hz	125 Hz	250 Hz	500 Hz	1000 Hz	2000 Hz	4000 Hz	8000 Hz	
TW200	60	78	86	89	92	93	86	79	97,4
TW400	63	81	89	92	95	96	89	82	100,4

Table 02 - Sound Pressure Level at 1 m in free field [dB]

Model	Octave Band Frequency								Total SPL [dB(A)]
	63 Hz	125 Hz	250 Hz	500 Hz	1000 Hz	2000 Hz	4000 Hz	8000 Hz	
TW200	41	59	67	70	73	74	67	60	78,2
TW400	42	60	68	71	74	75	68	61	79,3

Note 1 *The value of **PWL** (Sound Power Level) is calculated in according to ISO 3744 procedure method.
Sound Power Level tolerance for each octave band: -0 / +2 dB*

Note 2 *The value of **SPL** (Sound Pressure Level) for every octave band frequency is estimated in free field conditions and at 1 meter from the unit according to ISO 3744 average method.
Sound Pressure Level tolerance for each octave band: -0 / +2 dB*

Note 3 *Avoid positioning in rooms with high reverberation of the sound waves, which can adversely effect the noise levels.*

7. Installation Specifications

Content of this chapter

7.1 Site Specifications.....	23	7.4 Water System Preparation.....	25
7.2 Site Preparation.....	24	7.5 Electric System Specifications.....	26
7.3 Water Supply Specifications.....	25	7.6 Electric System Preparation.....	27

This chapter provide specifications and instructions for the following operations, which must be done by the customer before the unit installation.

- Preparing the area
- Preparing the piping for the water system
- Preparing the electric system



NOTICE

Vertiv™ takes no responsibility for systems not compliant with the specifications given in this manual. Lack of compliance to the specifications given by Vertiv™ voids the warranty.

7.1 Site Specifications

Location

The units must be installed indoors, in rooms protected from weather agents.

- Install the unit in an area with clean air, away from loose dirt and foreign matter.
- Make sure that the floor and the building structure are suitable to bear the weight of the unit and of the moving equipment.

Space requirements

See chapter 6.1 *Dimensions and Weight* for the unit dimensions

7.2 Site Preparation

Walls

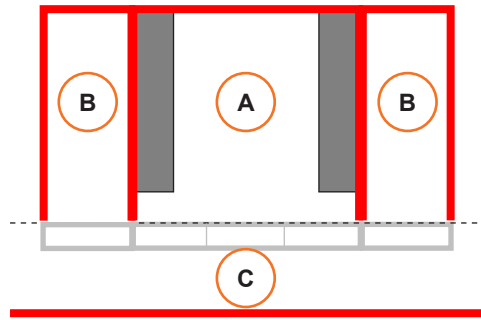

- Prepare walls that separate the following zones:
 - [A] room with the equipment to be cooled
 - [B] cold air zone
 - [C] corridor

Free air flow

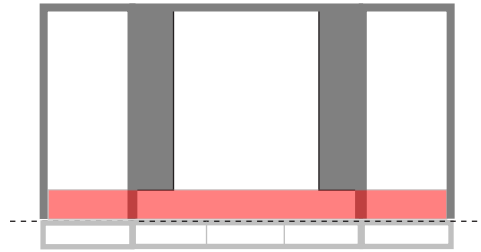

- Do not place any obstacle in front of the unit.

Service area

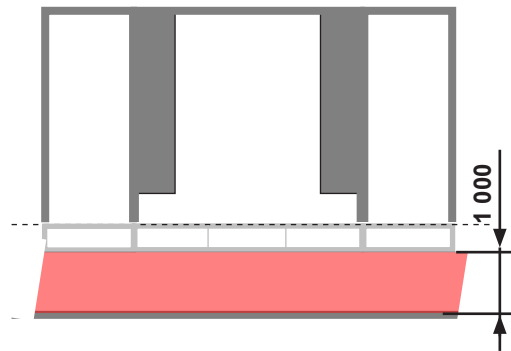

- Leave the free space shown in the figure to allow safe installation and maintenance operations.

Floor

- Prepare a level surface suitable to support the weight of the unit.
- Prepare a supporting plate or inserts for fixing the unit to the floor.
See *Annex A - Installation Drawings* for the holes position and specification.

Ceiling

- Prepare a supporting structure or inserts for fixing the unit to the ceiling.
See *Annex A - Installation Drawings* for the holes position and specification.

7.3 Water Supply Specifications

Analyze the water It is the user's responsibility to establish the quality of the water and make sure that this is compatible with the materials used in the exchangers.
 The quality of water may significantly affect the operation and the life of the exchangers.
 The first step in the planning the treatment of the water is chemical analysis, which must be performed by qualified personnel from specialist organizations.
 Water quality has to be in accordance with VDI 2035.

Add water softeners In tower water, the tendency to form deposits may be high: to reduce this phenomenon, there are various types of water softening treatments available, including the use of ion exchange resins.

Prevent corrosion The oxygen dissolved in water increases the rate of corrosion.
 The main factors causing corrosion are sulphur and carbon dioxide acids (see the Langelier and Ryznar indices).
 A combined effect of fouling due to dust and organic material provides a support for bacteria, fungi and algae; the growth of organisms may produce an oxygen gradient and this results in rather severe pitting of the metallic surface.
 The phenomenon of corrosion is obviously related to the material used on the liquid side of the heat exchanger.
 The table on the right shows the reference values for corrosion on copper, these values must be considered as guidelines to avoid corrosion.

pH	---	7,5 - 9,0
SO ₄	ppm	< 100
HCO ₃ / SO ₄	---	>10
Total hardness	dH	4,5 - 8,5
CJ-	ppm	< 50
PO43-	ppm	< 2,0
NH ₃	ppm	< 0,5
Free Chlorine	ppm	< 0,5
Fe3+	ppm	< 0,5
Mn++	ppm	< 0,05
CO ₂	ppm	< 50
H ₂ S	ppb	< 50
Temperature	°C	< 65
Oxygen content	ppm	< 0,1

7.4 Water System Preparation

Temperature and pressure See chapter *3.5 Operating Conditions*

Layout

- Prepare manifolds for water supply and return, with inlet and outlet connectors for each of the six coil modules.
- Place the manifolds so to avoid to obstruct the air flow through the unit.

Shut-off valves

- A shut-off valve must be installed at the inlet manifold for each of the six coil modules.

Filter

- If there is no filter on the water supply line, then install a filter before the unit.

7.5 Electric System Specifications

Power supply requirements for the unit	<ul style="list-style-type: none"> • Check the electrical data on the label applied on the unit. • Check that the available power supply is consistent with the unit power requirements given in chapter 6. <i>Technical Data</i>. • Refer to the electrical schematic supplied with the unit when making line voltage supply, low voltage main unit interlock and any low voltage alarm connections.
Local codes	<ul style="list-style-type: none"> • Electrical service must conform to national and local electrical codes. • All wiring must be done in accordance with all applicable local, state, and national electrical codes.
External disconnecting switch	<ul style="list-style-type: none"> • The customer must install on site an external disconnecting switch, easy to reach, to facilitate a quick and easy shutdown and power cut off of the unit, switch-disconnector must comply with IEC 60947-3, category AC-23B or DC-23B and installed at a height between 0.6 m and 1.9 m.
Protection	<ul style="list-style-type: none"> • Select and install the line side electrical supply wire and over current protection device(s) according to the specifications on the unit nameplate(s), per the instructions in this manual and according to the applicable national, state, and local code requirements. • The customer is responsible for the system protection. • Protect the system by a differential switch. • If the system includes devices with inverter, then use a type B or B++ RCD (Residual Current Device) switch.
Power supply variability	<ul style="list-style-type: none"> • Check that the maximum unbalance between the phases does not exceed the value given in chapter 6. <i>Technical Data</i>. • Make sure to comply with the following data: <ul style="list-style-type: none"> - Electrical voltage between 0.9 and 1.1 nominal voltage - Frequency between 0.99 and 1.01 the nominal frequency - Variability of supply voltage less than 2% <p>See the figure below for variability evaluation.</p>

Example of calculating phase to phase variability

- The 400 V supply has the following variability:
RS = 388 V
ST = 401 V
RT = 402 V

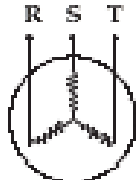

- The average voltage is:

$$\frac{388 + 401 + 402}{3} = 397$$
- The maximum deviation from the average is:
 $402 - 397 = 5 \text{ V}$
- The phase to phase variability is:

$$\frac{5}{397 \times 100} = 1.26 \text{ (acceptable)}$$

Power supply connection

The units are equipped with electrical devices (power supplies module, control devices, ...) that are designed to operate properly with star-connected power (Wye) with earthed neutral (TN or TT system). If you need three-phase distribution Delta-connected (Δ) or Star-connected power (Wye) without ground or floating ground (IT) please contact Vertiv™.

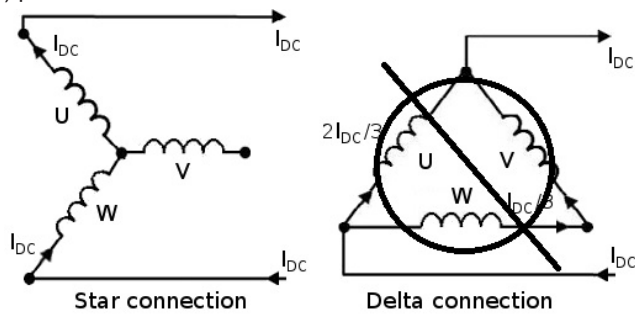

Power supply type	<p>Acceptable:</p> <ul style="list-style-type: none"> - TT, TN-S, TN-C, TN-C-S systems - 460 V Wye with solidly grounded neutral (266 V line to ground) - 380 V Wye with solidly grounded neutral (220 V line to ground) <p>Unacceptable:</p> <ul style="list-style-type: none"> - 380 to 460 V Wye without ground connection or with high-resistance (or impedance) ground (IT). - 380 to 460 V Δ without ground or with high-resistance (or impedance) ground (IT). - 380 to 460 V Δ with corner ground or with grounded center-tapped.
Cables type	<ul style="list-style-type: none"> • Use copper wiring only. <p>The units are equipped with electrical panel with one main switch for the power section. Choose a supply cable (four-pole type with ground) for the power section, according to:</p> <ul style="list-style-type: none"> - the local norms - the system absorption (FLA unit) - the system voltage - installation type - cable length - upstream protection
Cables connection	<ul style="list-style-type: none"> • The general alarm terminals allow remote alarm signaling. • In case of short circuit, check the sticking of the involved switch and replace it.
Check integrity	<ul style="list-style-type: none"> • Make sure that all electrical connections are tight. • Make sure that all electrical components are undamaged.
Hot surfaces	<ul style="list-style-type: none"> • The cables must not touch hot surfaces. If necessary, wrap the electrical cables by a thermal insulating sheath.

7.6 Electric System Preparation

Bus duct	<ul style="list-style-type: none"> • Prepare a power supply cable for the control panel. • Prepare a bus duct for the fans power supply. You need six sockets placed above the unit. <p>See chapter 6. <i>Technical Data</i> and the <i>Electric Diagrams</i> provided with the unit</p>
-----------------	--

8. Handling

Content of this chapter

8.1 Safety Instructions.....	29	8.5 Unpacking.....	31
8.2 Inspection.....	29	8.6 Handling without Package.....	32
8.3 Storage.....	29	8.6.1 Handling a whole section of the unit.....	32
8.4 Transport with Package.....	30	8.6.2 Handling a fan module.....	33
8.4.1 Using a fork lift.....	30	8.6.3 Handling the coil modules.....	34
8.4.2 Using a crane.....	30		

This chapter explains how to handle the unit or its modules in the following situations.

- Shipping
- Moving to a storehouse
- Moving to the installation site.

8.1 Safety Instructions



WARNING

Improper operations can cause injury or death.

Verify that all the lifting and moving equipment is rated for the weight of the unit before attempting to move, lift, remove packaging from or prepare the unit for installation.

Make reference to the local safety regulations about lifting and handling heavy loads.



NOTICE

Improper operations can cause product damage.



Read carefully the chapter *1. Safety*.

Pay attention to the safety labels on the unit and to the safety warnings in this chapter.

8.2 Inspection

- After receiving the product, check the content of the box against the packing list.
- If any parts are missing, please report to the carrier immediately.
- If you find any damage, please report to the carrier and to the local distributor too.

8.3 Storage



NOTICE

Improper storage can cause product damage.

See chapter *3.6 Storage*

8.4 Transport with Package

8.4.1 Using a fork lift

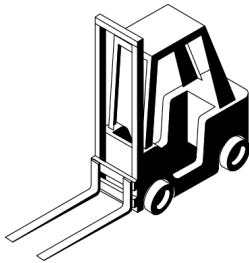
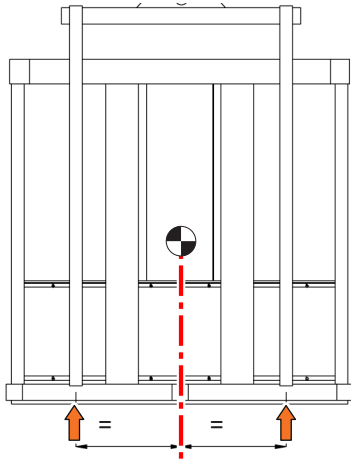

- Make sure that the fork length and distance is suitable for the unit length and to ensure the unit stability.
- Spread the forks to the widest allowable distance to still fit under the pallet.
- Lift the unit from the side that is indicated in the instructions on the package.
- Make reference to the local safety regulations about lifting and handling heavy loads.



WARNING

Pay attention to overhead obstacles, for example doorways.

8.4.2 Using a crane

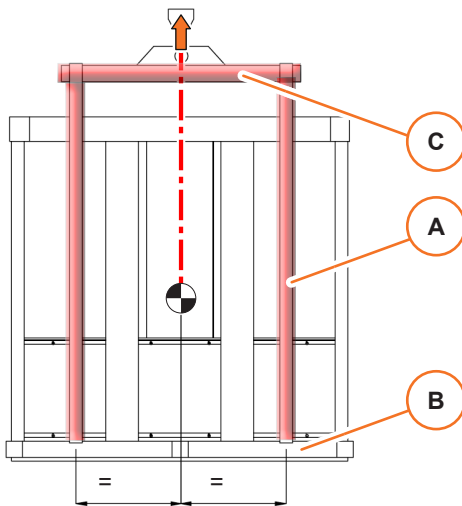

- Place the slings [A] between the unit bottom rails and the pallet [B], at the widest allowable distance.
- Be sure that the distance between slings guarantees the unit stability.
- Fix the slings to a spreader bar [C]



WARNING

The unit is supplied in two modules placed side by side.

Do not use the eyebolts that are fixed on top of the unit to lift the two modules together.

These eyebolts can only be used to lift the single module, after it has been removed from the package.



NOTICE

Lift the unit with a speed suitable for the load to be moved, so as not to damage the structure.

8.5 Unpacking



- Remove the exterior packaging material from around the unit.
- Remove the top cover, the corner and the side planks.



ENVIRONMENT

All material used to package this unit is recyclable. Please save for future use, or dispose the package materials according to the local regulation about waste disposal.

NOTE *The upper and the lower section of the unit are mounted on the same pallet.*



- Remove the packages placed inside the box (containing remote sensors, accessories,...).



NOTICE

Pay attention not to damage the cables connectors for the fans.

8.6 Handling without Package



NOTICE

You may remove either a whole section of the unit (three coil modules and one fan module assembled together), or you may remove a fan module, if delivered on its own.

Do not remove single coil modules or components detached from the rest.

See Annex *Annex A - Installation Drawings* for details about dimensions and lifting or fixing points.

8.6.1 Handling a whole section of the unit

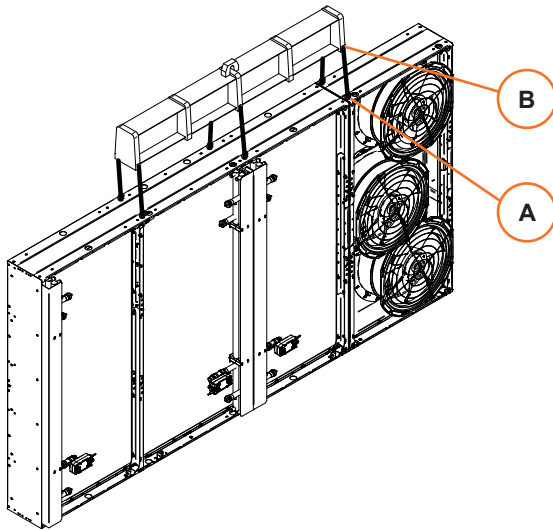

- Insert a sling or a chain in the eyebolts [A] of the section you want to move.
- Fix the slings or chains to a 6-points lifting bar [B].

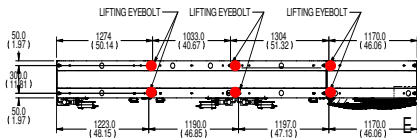
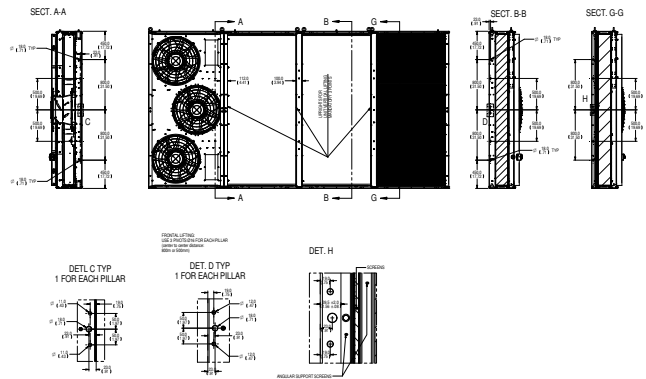

See also *Annex A - 3 Installation Specifications*

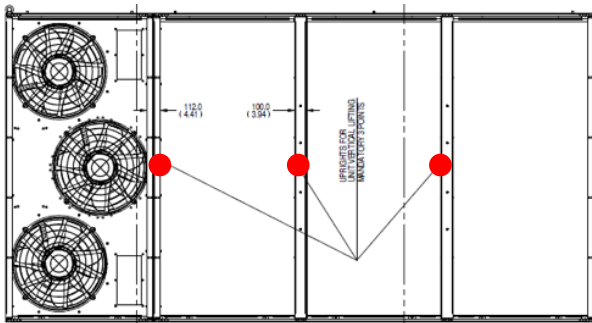

- Or alternatively, if you need to use a fork-lift, fix your lifting tool to the fixing points on the uprights on the back.



NOTICE

You must use at least three fixing points.

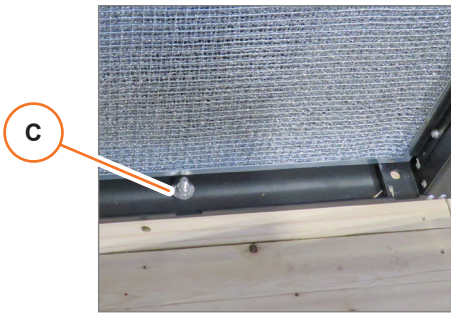

- Remove the bolts [C] that fix the unit to the pallet or any other support used for the transport.
- Lift slightly the unit and remove the pallet.



NOTICE

Lift the unit with a speed suitable for the load to be moved, so to avoid damage to the structure.



NOTICE

When you remove from the pallet the first section of the unit, pay attention to avoid oscillations and avoid to hit the other section that is still fixed on the same pallet.

- Move the unit section to the installation site.



WARNING

Two persons are needed to prevent swinging and to guide the unit section to the right position.

8.6.2 Handling a fan module

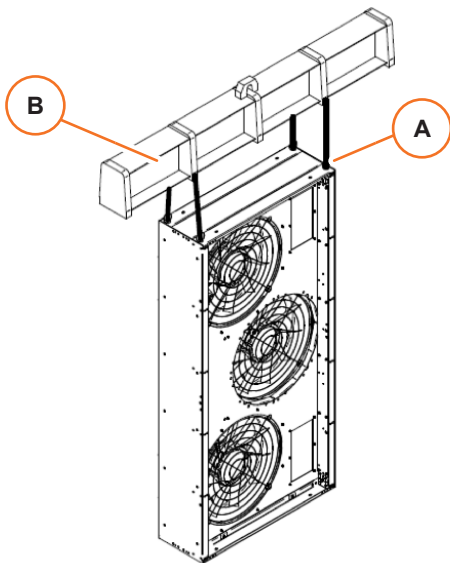

- Insert a sling or a chain in the eyebolts [A].
- Fix the slings or chains to a 4-points lifting bar [B].

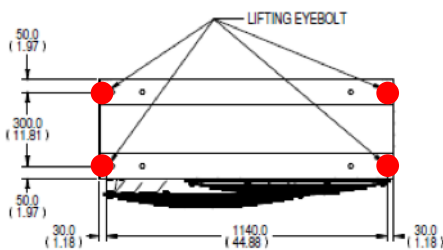

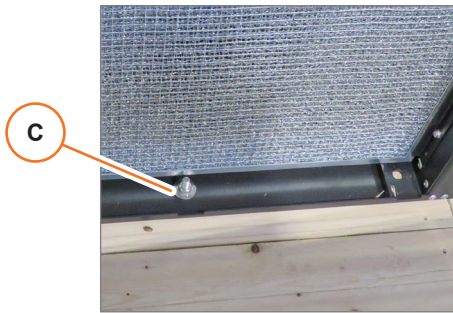

- Remove the bolts [C] that fix the fan module to the pallet or any other support used for the transport.
- Lift slightly the fan module and remove the pallet.



NOTICE

Lift the fan module with a speed suitable for the load to be moved, so to avoid damage to the structure.

- Move the fan module to the installation site.



WARNING

Two persons are needed to prevent swinging and to guide the fan module to the right position.

8.6.3 Handling the coil modules



NOTICE

This operation may be done in case need to change the position of the modules depending on the building layout. See chapter 9.4 *Rearranging the Modules* for details.

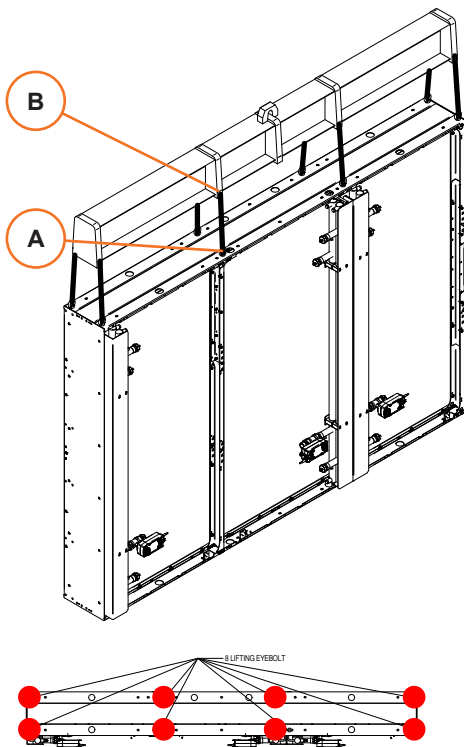

- Insert a sling or a chain in the eyebolts [A].
- Fix the slings or chains to a 8-points lifting bar [B].



NOTICE

Lift the module with a speed suitable for the load to be moved, so to avoid damage to the structure.

- Move the module to the installation site.



WARNING

Two persons are needed to prevent swinging and to guide the module to the right position.

9. Assembly

Content of this chapter

9.1 Safety Instructions.....	35	9.3.5 Fixing the upper section on the lower section.....	39
9.2 Overview.....	35	9.3.6 Fixing the unit to the ceiling.....	40
9.3 Assembling the Unit.....	36	9.4 Rearranging the Modules.....	40
9.3.1 Positioning the lower section.....	36	9.4.1 Configurations.....	41
9.3.2 Fixing the lower section on the floor.....	36	9.4.2 Removing a coil module.....	42
9.3.3 Preparing the upper section.....	37	9.4.3 Removing a fan module.....	45
9.3.4 Positioning the upper section.....	38		

9.1 Safety Instructions



WARNING

Improper operations can cause injury or death.

Verify that all the lifting and moving equipment is rated for the weight of the unit before attempting to move, lift, remove packaging from or prepare the unit for installation.

Make reference to the local safety regulations about lifting and handling heavy loads.



WARNING

The assembly operations require working at height. Use safety ladders and platforms. Wear helmet and safety gears. Operate according to local safety regulations about working at height.



NOTICE

Improper operations can cause product damage.



Read carefully the chapter *1. Safety*.

Pay attention to the safety labels on the unit and to the safety warnings in this chapter.

9.2 Overview

Site preparation	See chapter <i>7. Installation Specifications</i>
Accessories and equipment supplied with the unit	<p>Make sure that the following items are available:</p> <ul style="list-style-type: none"> - eyebolts on top of each section of the unit - gasket to be placed between the lower and the upper section - lifting accessory for handling of the coil modules
How to assemble the two sections of the unit and fix the unit to the floor and to the ceiling	See chapter <i>9.3 Assembling the Unit</i>
Connect the water piping, the remote sensors and the power supply	See chapter <i>10. Connections</i>
How to change the position of the fan modules depending on the building layout	See chapter <i>9.4 Rearranging the Modules</i>

9.3 Assembling the Unit

NOTE Make also reference to Annex A - Installation Drawings for details.

9.3.1 Positioning the lower section

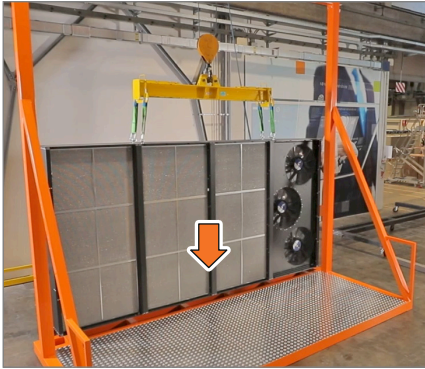

- Lift the lower section as explained in 8. *Handling* and move it to the final position on top of the supporting plate or inserts prepared on the floor.

9.3.2 Fixing the lower section on the floor

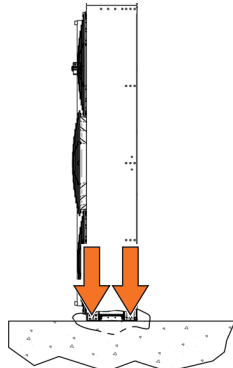
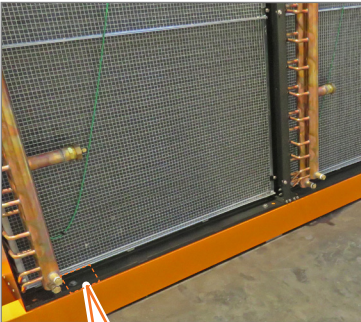

6X + 6X M12



A

- At both sides, insert the bolts **[A]** (with the washers) in the holes in the supporting plate or inserts prepared on the floor.
- Tighten the bolts.

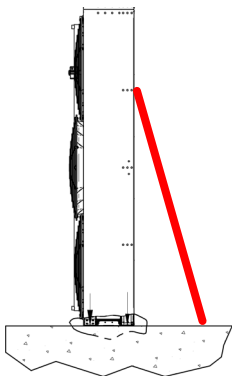

WARNING

Set props against the lower section in order to prevent tipping over during the assembly operations.



- Remove the slings and the eyebolts.
- Place the gasket (provided with the unit) on top of the lower section.

9.3.3 Preparing the upper section



WARNING

The top of the unit must be fixed to the building structure in order to prevent tipping over.

The fixing method depends on the layout of the installations site

You can use the slots on top of the upper section.

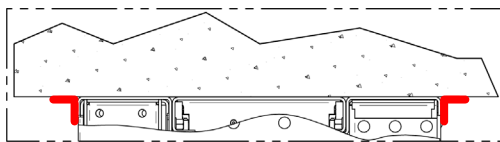
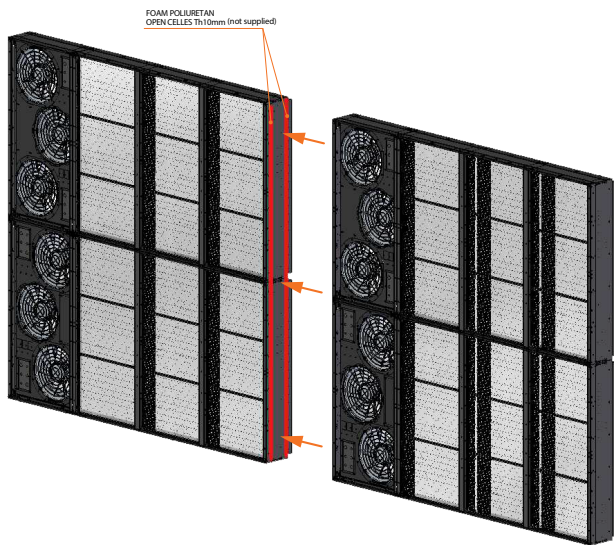
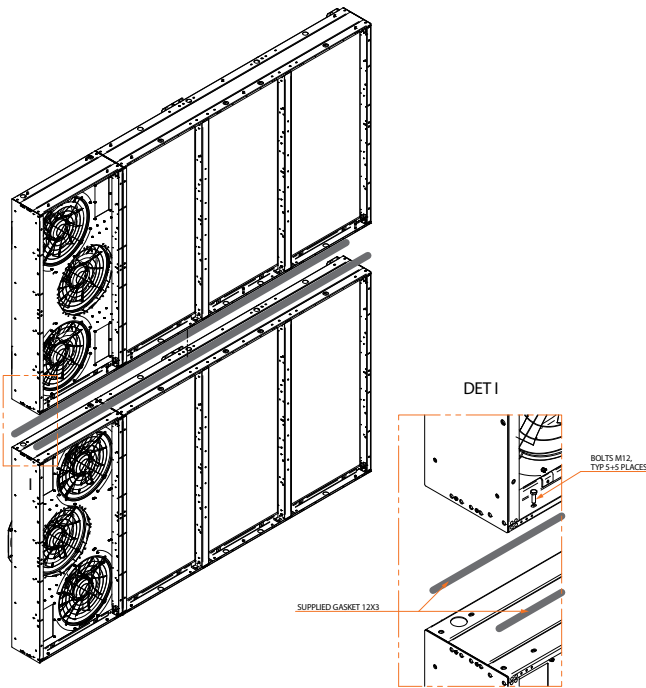

As alternative, you may fix two couples of angular brackets on both sides.

9.3.4 Positioning the upper section

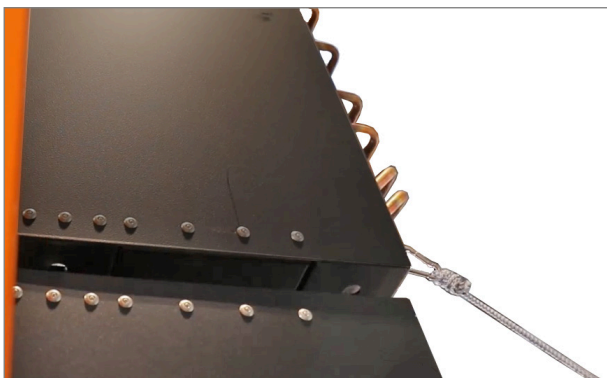

- Fix two ropes on the lower part of the structure to prevent swinging and to guide the unit to the right position.



- Lift the upper section as explained in 8. *Handling* and move it to the final position on top of the lower section.

9.3.5 Fixing the upper section on the lower section

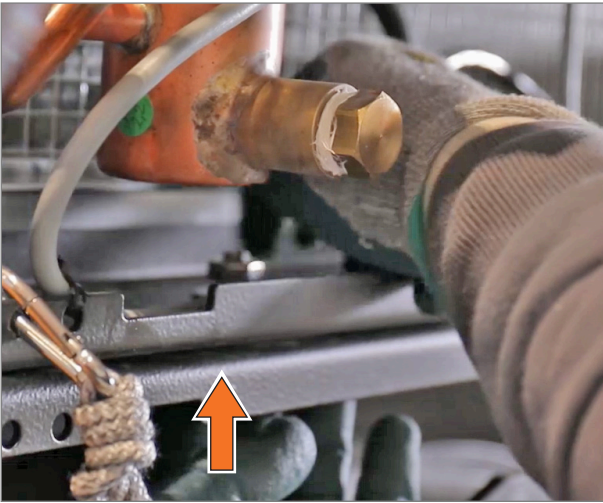

- Keep the unit upper section hanging as close as possible over the lower section.
- Align the holes of the two sections.

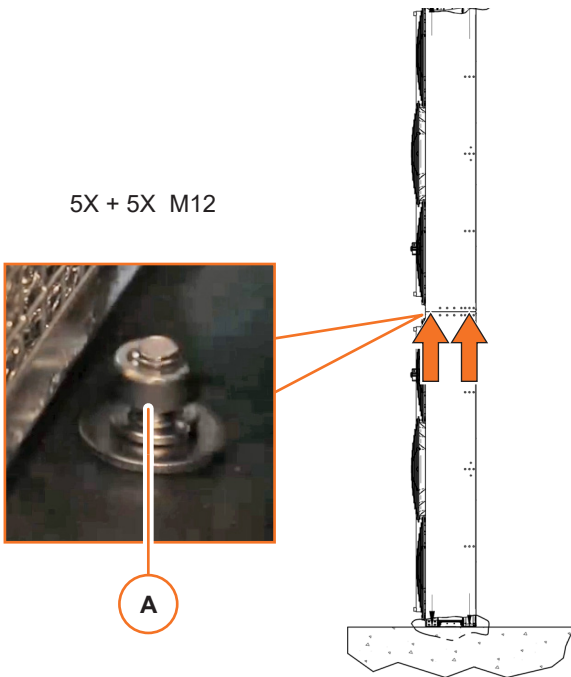

- At both sides, insert the bolts **[A]** in the holes.
- Insert washer, spring washer and nut.
- Do not tighten the nuts yet.
- When you have inserted all the bolts and the two sections are well aligned, lower completely the upper section and tighten the nuts.

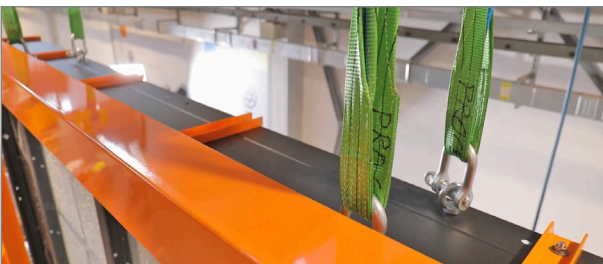

WARNING

The unit might tip over. Keep the unit hanging from the lifting equipment. Do not release the slings before the next step is completed.

9.3.6 Fixing the unit to the ceiling

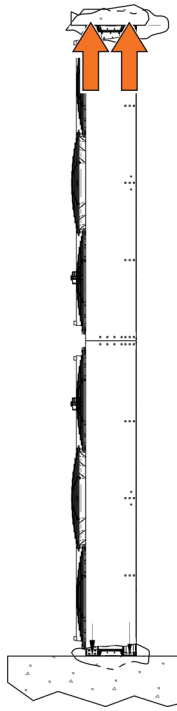

- Fix the top of the unit to the building structure.



NOTICE

The purpose of this fixing is only to keep the unit upright. The unit is not designed for hanging from the ceiling.

9.4 Rearranging the Modules

This chapter explains how to remove the coil and the fan modules in case you need to change the position of the fan modules depending on the building layout.

Proceed in reverse order to reassemble.



NOTICE

Do not remove more than one modules at a time. The structure might collapse.



NOTICE

Each module in the lower section must be matched with a module of the same type in the upper section: fan module with fan module, coil module with coil module

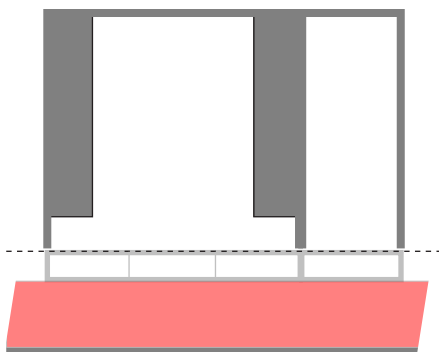

NOTE Do the operations explained in this chapter from the corridor.

9.4.1 Configurations

You may arrange the coil modules in the following configurations:

Configuration 1



Standard

Configuration 2



Left side water coil rotated 180°

Configuration 3

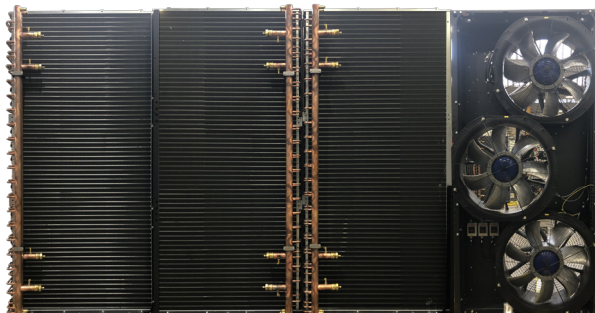

Middle water coil rotated 180°

Configuration 4



Left side and middle water coils rotated 180°

9.4.2 Removing a coil module

Drain the water

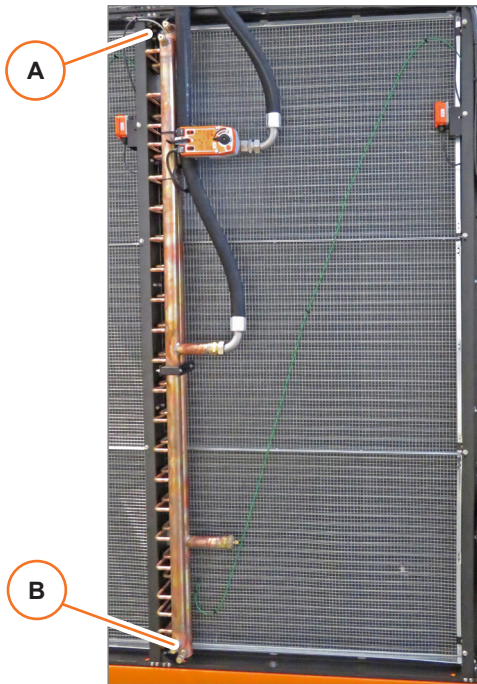

► Skip this step if the water piping is not connected yet.

- Close the water supply (building facility) to the coil module that you want to remove.
- Open the vent valve [A].
- Open the drain valve [B] and drain all the water from the coil module.

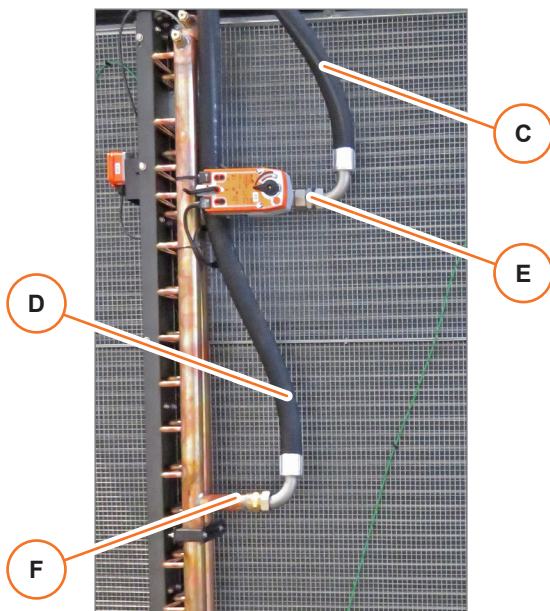

- Disconnect the flexible piping [C] and [D] from their connections [E] and [F].

Remove the cables

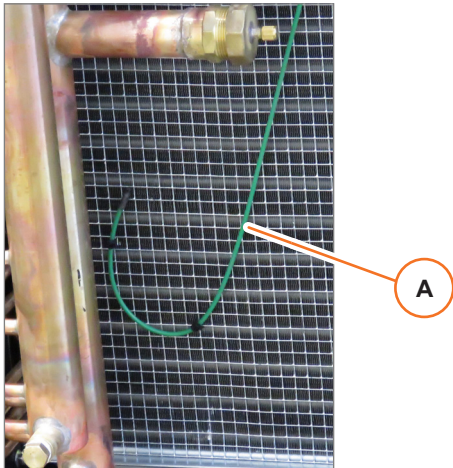

- Remove the cable [A] of the temperature sensor.

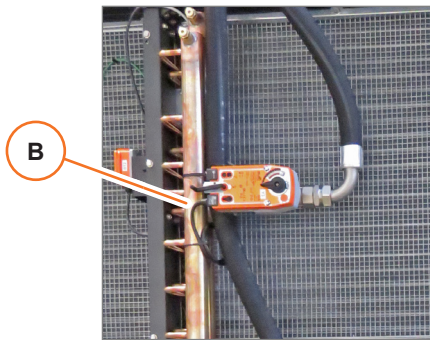

- Remove the cable [B] of the servo valve.

Remove the net

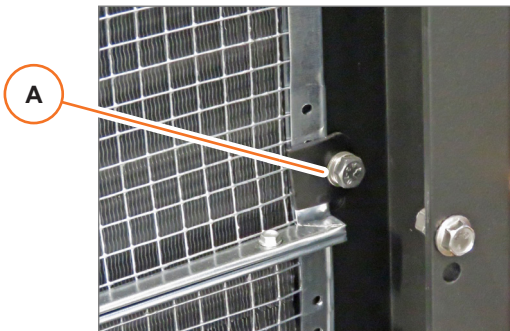

- Remove the screws [A] that fix the net on the coil.

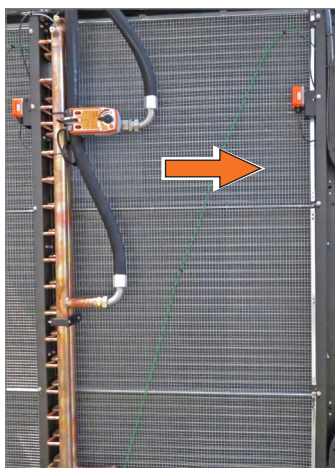

- Slide the net to the side and remove it gently.

Loose the coil module

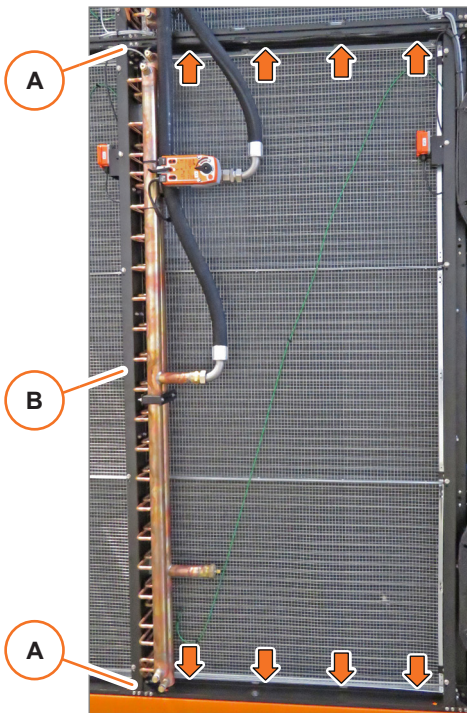

- Loose the screws [A] to release the vertical beam [B].
- Remove the screws that fix the module to the structure at top and bottom (4 + 4 screws).

Remove the coil module

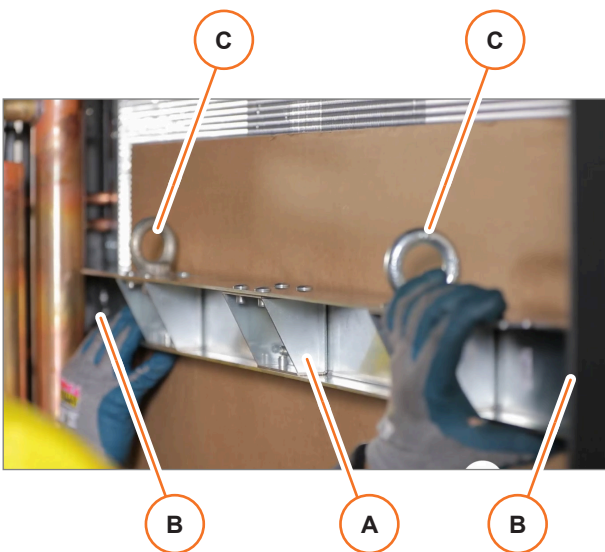

WARNING

Use the handling kit provided with the unit to handle the coils. Make reference to the *Lifting Bar Manual* for details.

- Place a cardboard on the coil, for protection.
- Fix the lifting bar [A] to the coil by 4 screws provided in handling kit using the holes [B] that you find in the frame.
- Insert the slings in the eyebolts [C].
- Strain the slings.



- Remove the coil module from the unit.

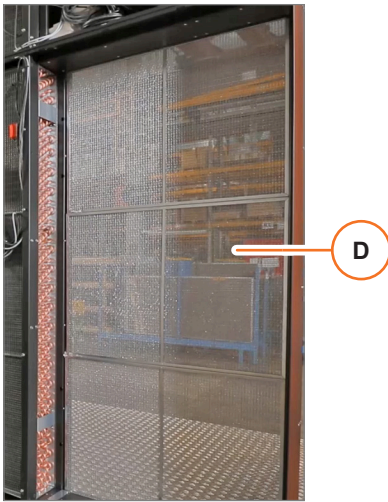

- If you are going to mount a fan module in place of a coil module, then remove the grids [D].

9.4.3 Removing a fan module

Loose the fan module

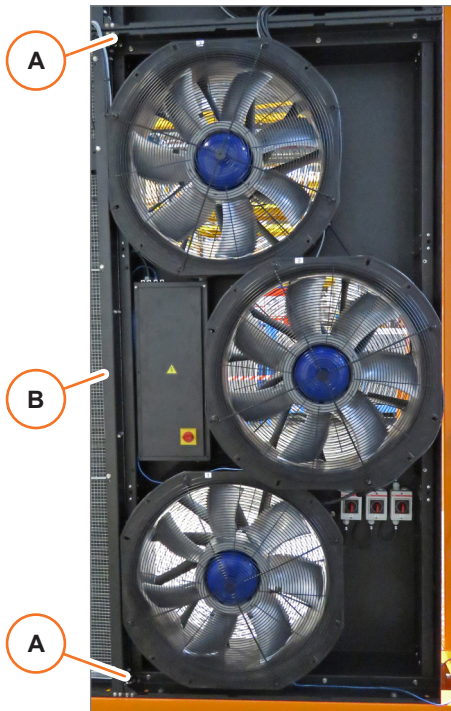

- Loosen the screws [A] to release the vertical beam [B].

Remove the fan module



WARNING

Use proper lifting tools to handle the fan module.

- Fix a lifting equipment to the fan module.
- Remove the screws that fix the module to the structure at top and bottom (4 + 4 screws).
- Remove the fan module from the unit.

10. Connections

Content of this chapter

10.1 Safety Instructions.....	47	10.6 4-20mA Connections.....	52
10.2 Water System.....	48	10.6.1 Connecting the remote humidity and temperature sensors.....	52
10.2.1 Connecting the piping.....	48	10.6.2 Checking the 4-20mA connections.....	53
10.2.2 Filling the coils.....	48	10.6.3 Setting the Modbus addresses.....	53
10.3 Electric Power Supply.....	49	10.7 Final Checks.....	53
10.3.1 Connecting the control panel without ATS.....	49		
10.3.2 Connecting the control panel with ATS.....	49		
10.4 User Interface and Network Connection.....	50		
10.5 Connecting the Differential Pressure Sensor.....	50		

10.1 Safety Instructions



WARNING

Improper operations can cause injury or death.



NOTICE

Improper operations can cause product damage.



Read carefully the chapter *1. Safety*.

Pay attention to the safety labels on the unit and to the safety warnings in this chapter.

10.2 Water System

10.2.1 Connecting the piping

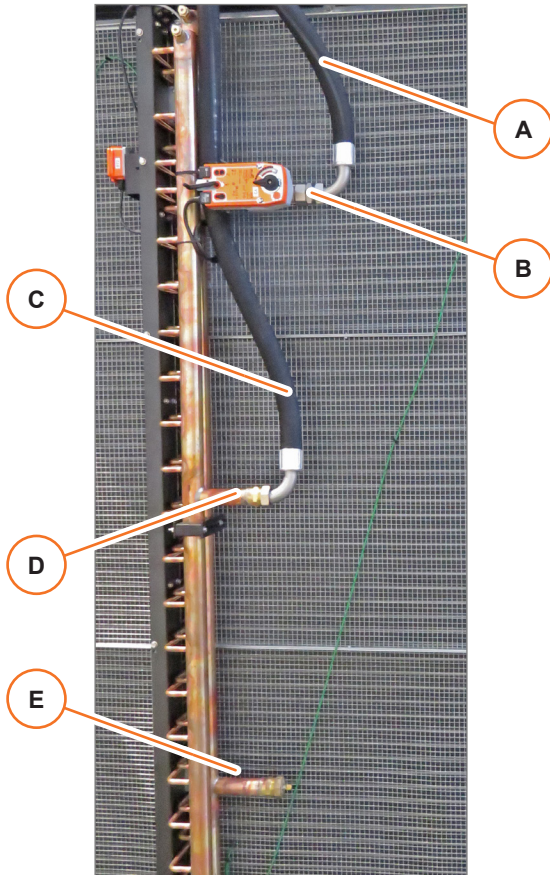

- If the flexible pipings are provided with the unit, then make sure that they are undamaged.
- Make sure that there is no loose material inside the pipings.
- Check the production date marked on the piping: the piping has a 10 years guarantee from the production date.
- Connect the piping [A] to the water supply manifold (building facility) and to the coil inlet connection [B].
- Connect the piping [C] to the water return manifold (building facility) and to the coil outlet connection [D] or [E] (depending on the position of the water manifolds in the building).



NOTICE

Pay attention. Do not mistake the inlet connection for the outlet connection and vice versa.



NOTICE

Remember to insert a gasket at each connection.

10.2.2 Filling the coils

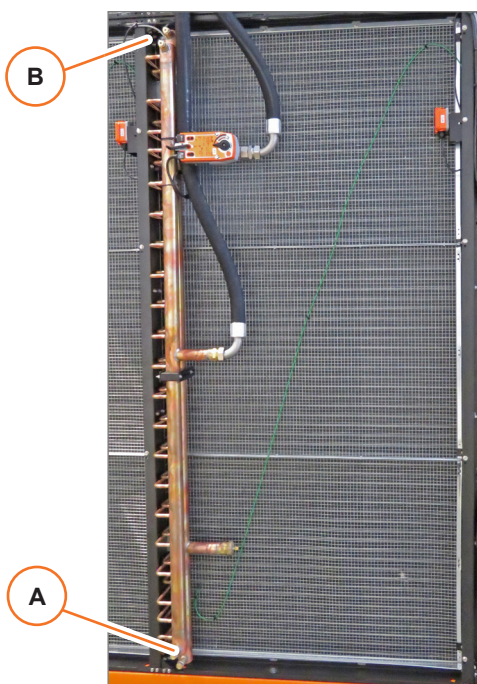

For each coil:

- Make sure that the drain valves [A] are closed.
- Open the vent valves [B].
- If there are shut-off valves on the water return (building facility), then make sure that they are open.
- Open the water supply valves (building facility) .
- Close the vent valves [B] when only water and no air blows out of them.

10.3 Electric Power Supply

10.3.1 Connecting the control panel without ATS

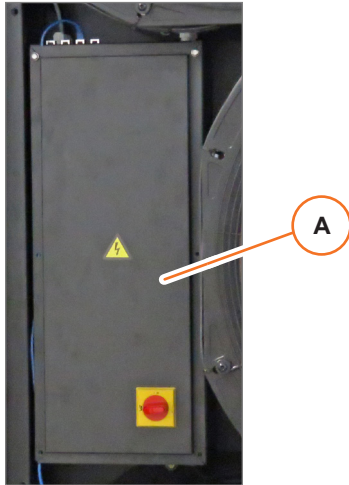

- Unscrew the cover [A].

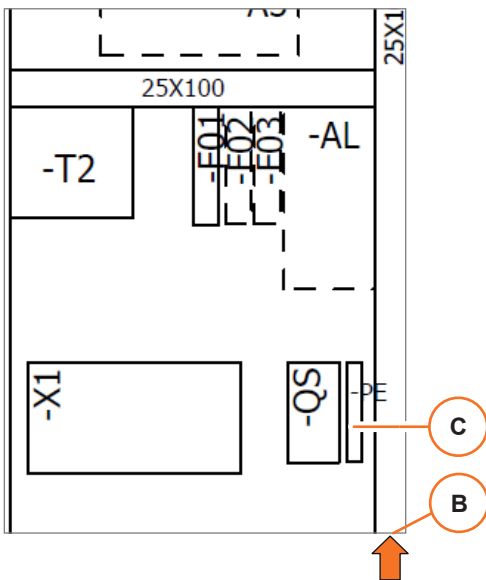

- Run the power cable from the bottom through the cable gland [B].
- Connect the power cable to the terminals of the disconnecting switch [C].
- Mount again the cover.

10.3.2 Connecting the control panel with ATS

- Unscrew the cover [A]
- Run the power cable from the top through the cable gland [B]
- Connect the power cable to the terminals of the ATS [C]
- Mount again the cover

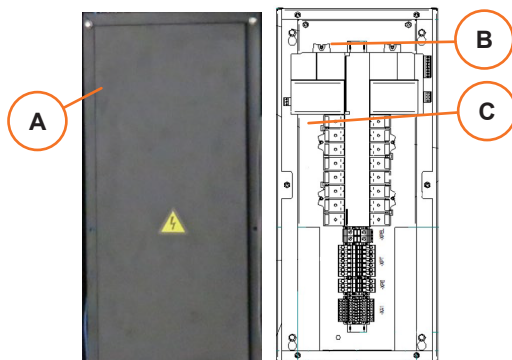

10.4 User Interface and Network Connection

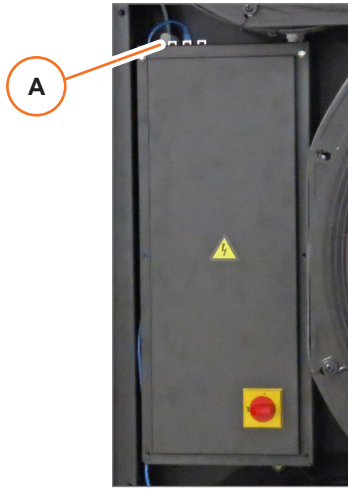

Use the network ports [A] for the following connections:

- laptop for the unit configuration and diagnostic interface
- network with the other units of the same room or building

10.5 Connecting the Differential Pressure Sensor

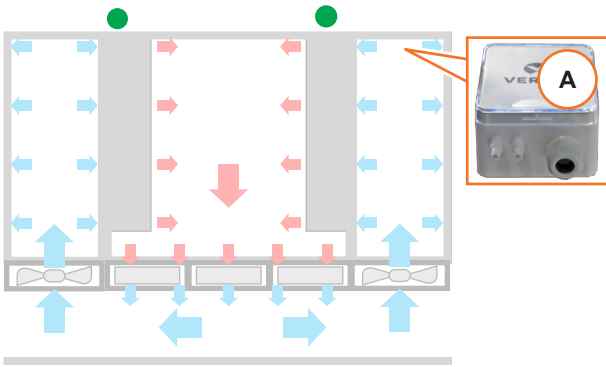

- Install the differential pressure sensor [A] according to their manufacturers instructions.

The two pressure probes ● must be placed at the far end of the room, one on each side of the equipment to be cooled.

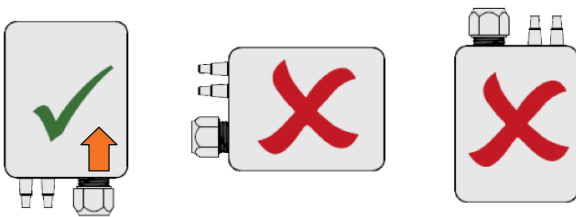

- Make sure that the orientation of the pressure sensor is correct.

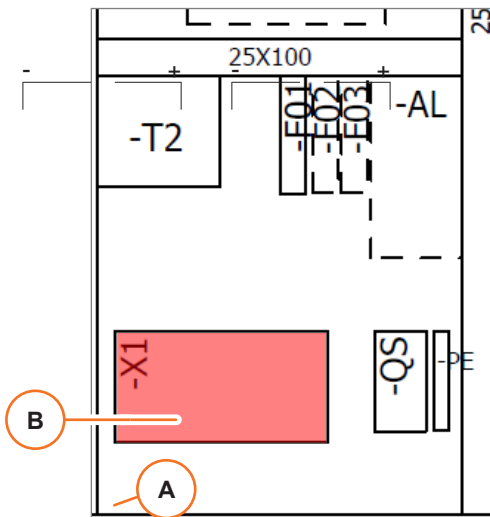

- Run the cable from the bottom through the cable gland [A].
- Connect the cable to the terminals in the panel [B].
- Differential pressure sensor connection scheme [C]

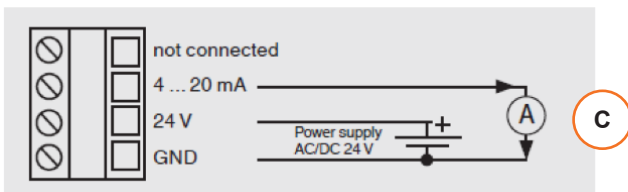

- Place the jumpers of the pressure sensor to set the measuring range.
- Make reference to *Operating instructions A2G-50* for details.



10.6 4-20mA Connection

10.6.1 Connecting the remote humidity and temperature sensors

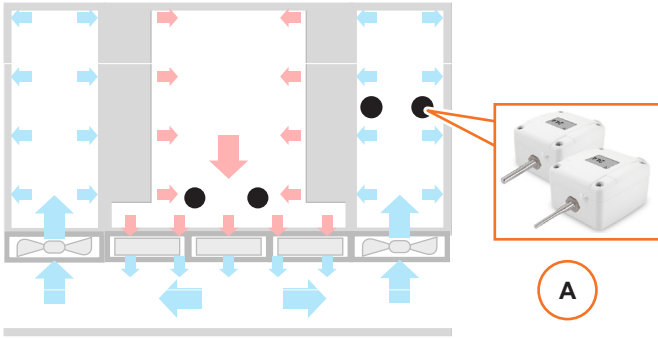

- Install the humidity and temperature sensors [A] according to their manufacturers instructions.
- Two probes ● must be placed in the cold zone, other two probes must be placed in the warm room.

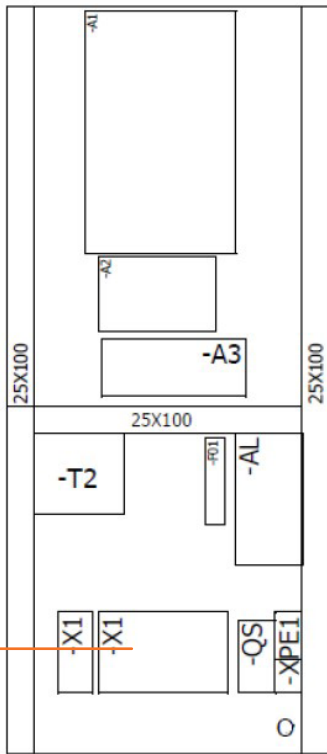

- Run the cable from the bottom through the cable gland [A].
- Connect the cable to the terminals in the panel [B].

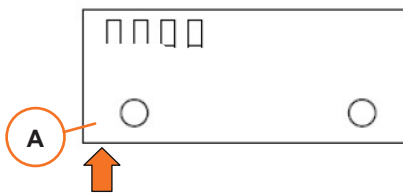

10.6.2 Checking the 4-20mA connections

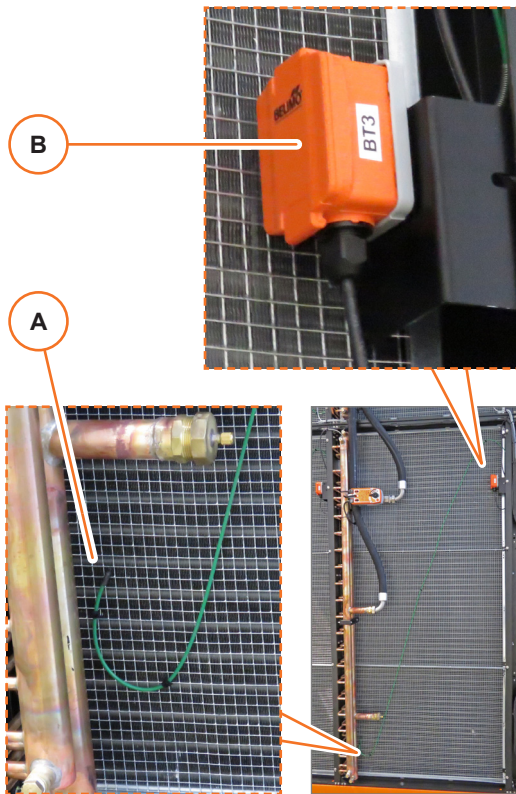

- Check that the temperature sensors are already mounted on each coil and that they are connected.

► If necessary:

- Fix the probe [A] on the coil.
- Mount the box [B] and connect it to the terminals in the panel.

See the *iCOM™ User Manual* for details.

10.6.3 Setting the Modbus addresses

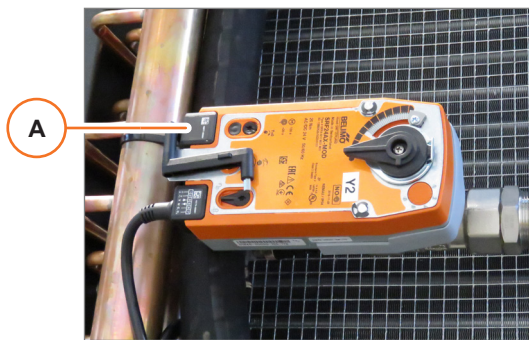

► If you need to set the Modbus addresses of a device:

- For the water servo valves: plug in the connector [A] the display provided by the manufacturer.
- For the fans: connect the fan to a laptop and use the configuration software provided by the manufacturer.

See the manufacturers documentation and the *iCOM™ User Manual* for details.

10.7 Final Checks

NOTE Follow these instructions at first start-up and also in case of restart after a long stop.

NOTE Record the functional data on the Start-Up certificate.

Electric system



WARNING

Disconnect the power supply before doing the following checks on the electric system as explained in *1. Safety*.

- Check all the cable connections particularly the main power connections on the power fuses and contactors.
- Check that all thermal protections are calibrated according the electrical data tables reported on wiring diagram.
- Check the electrical absorption of all components.

Tightness	After finishing all of the connections and installation operations, check all the unit edges and gaps and make sure that they comply with the protection degree IP2x specification (protection against finger access).
Air system	<ul style="list-style-type: none">• Check that the fans operate properly.• Check that all the sensors read a correct value.
Safeguards	<ul style="list-style-type: none">• Make sure that all the safeguards (panels, grids) have been mounted again.
Everything OK?	Start the normal operation: see <i>11. Operation</i>

11. Operation

Content of this chapter

11.1 Safety Instructions.....55	11.3 Start and Stop.....56
11.2 Power-up.....55	11.4 Disconnection from the Power Supply.....56

11.1 Safety Instructions



WARNING

Improper operations can cause injury or death.



NOTICE

Improper operations can cause product damage.



Read carefully the chapter *1. Safety*.

Pay attention to the safety labels on the unit and to the safety warnings in this chapter.



NOTICE

The power supply should never be disconnected during normal operation, except when performing maintenance.

11.2 Power-up



B

A

C

- Close the disconnection device upstream the unit (building facility).
- Close the disconnecting switch **[A]**.
- Close the disconnecting switches **[B]** and **[C]** of each fan.
- In case of first start-up or after maintenance on the electric system, check again by a voltmeter or tester if the voltage and phase difference fall within the indicated limits.



WARNING

In case of missing communication with the control the fans start immediately if the watchdog speed is higher than 0%.

11.3 Start and Stop

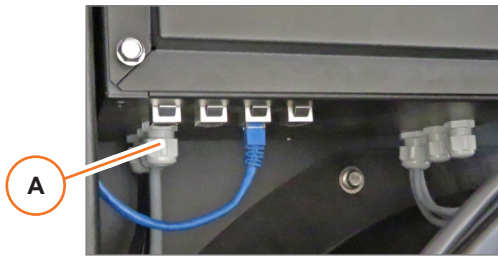

First start-up and in case of restart after a long stop

- Connect a laptop to the port [A] to access the unit configuration and diagnostic interface.
- Make sure that the unit is connected in the network with the other units of the same room or building.
- Check if there is any alarm and reset if necessary.
- Adjust the operating parameters.
- Start the unit.

See the *iCOM™ User Manual* for details.

Operation



CAUTION

The unit starts and stops automatically.

11.4 Disconnection from the Power Supply

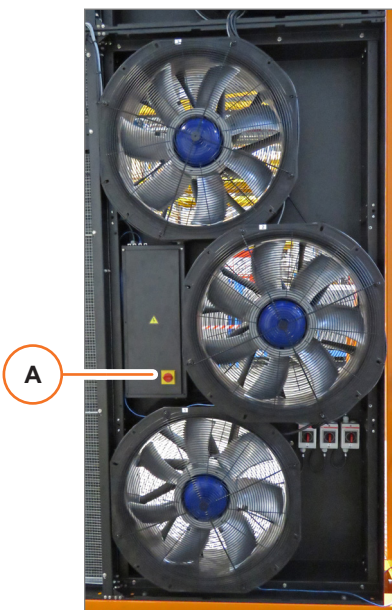

Control system

- Open the disconnecting switch [A]
This operation cuts off the power to the control panel, with the following result:
 - the fans continue to run at a preset speed
 - the water servo valves open completely



WARNING

Pay attention to the cables and components that are still energized.



Fans

- Open the disconnecting switches [B] for the upper fans.
- Open the disconnecting switches [C] for the lower fans.

12. Maintenance

Content of this chapter

- 12.1 Safety Instructions.....59
- 12.2 Maintenance Program.....60
- 12.3 Replacement of Components.....61
 - 12.3.1 Spare parts.....61
 - 12.3.2 Replacing a coil or fan Module.....61
 - 12.3.3 Replacing a Modbus device.....61
 - 12.3.4 Replacing a fan.....61
- 12.4 Troubleshooting.....62

12.1 Safety Instructions



WARNING

Improper operations can cause injury or death.

The final user may only do the operations that are specifically mentioned in this manual.
For any other operation you must contact Vertiv™.



NOTICE

Improper operations can cause product damage.



NOTICE

Check the unit regularly and solve the problems as they occur.
Lack of maintenance could reduce the performance or damage the unit.



Read carefully the chapter *1. Safety*.

Pay attention to the safety labels on the unit and to the safety warnings in this chapter.

12.2 Maintenance Program

Perform the periodic checks and maintenance operations as specified in the following table.

Component or function	Operation
<p>Water pipings</p> 	<ul style="list-style-type: none"> • Check the condition of the piping and gaskets, replace if necessary. <div data-bbox="901 477 1466 636" style="border: 1px solid #ccc; padding: 5px; margin-top: 10px;"> <p>NOTICE</p> <p>Check the production date marked on the piping: the piping has a 10 years guarantee from the production date. Replace the piping before the expiring date.</p> </div>

NOTE Hoses not provided by Vertiv™.

12.3 Replacement of Components

12.3.1 Spare parts

The use of original spare parts is recommended. Using third-party material can invalidate the warranty. When placing an order refer to the “Component List” enclosed with the unit and quote the unit model and serial number.



NOTICE

If you need to replace a component, then follow carefully the instructions of the manufacturer that come with the component.

12.3.2 Replacing a coil or fan Module

See 9.4 *Rearranging the Modules.*

12.3.3 Replacing a Modbus device

See 10.6 *Modbus Connections.*

12.3.4 Replacing a fan

Disassembly



- Open the disconnecting switch inside the main electrical panel.
- Open the cover of the fan motor and disconnect the fan power cable and the Modbus cable.
- Remove any tie or clamp fixing the cable to the structure.

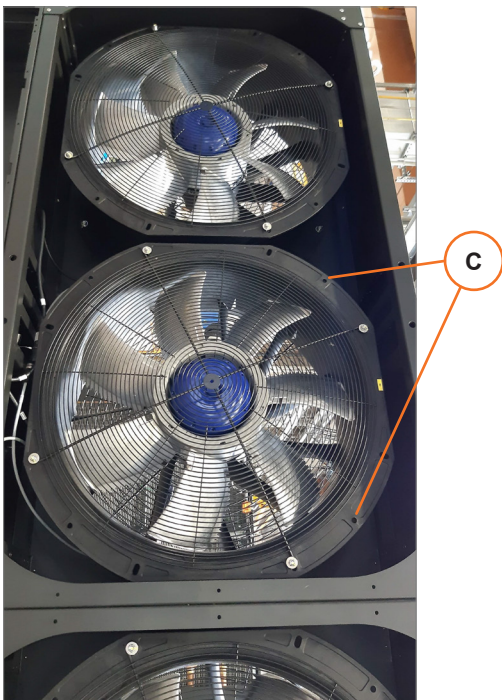

- Insert two shackles in the holes [C].
- Insert the slings in the shackles and strain the slings.
- Remove the screws fixing the fan to the structure.
- Remove the fan from the unit.



CAUTION

The fans are heavy.
This operation must be done by **two** maintenance operators.
Use adequate lifting equipment.

NOTE *Make reference to the fan manufacturer instructions for transport, handling and mounting the fans.*

Reassembly

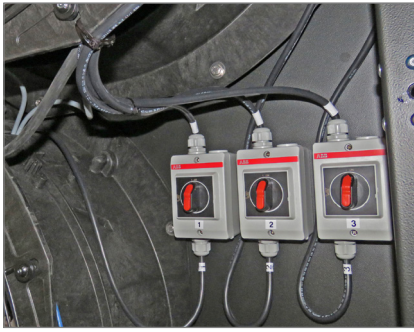

- Proceed in reverse order to reassemble the fan.
- Close the disconnecting switch inside the main electrical panel.
- Connect the fan to a laptop and use the configuration software provided by the manufacturer to set the Modbus address.

See the fan manufacturers documentation and the *iCOM™ User Manual* for details.

12.4 Troubleshooting

Symptom	Possible Cause	Check or Remedy
The unit does not start	No power supply to the unit	Check voltage at input terminal block
	The circuit breaker or fuse for low-voltage transformer in unit is tripped	Locate the problem in unit control panel and repair
	No signal to/from the remote sensors	Locate the problem on the Modbus line and repair.
High vibration on the unit	A fan is not properly fixed	Check the fan fixing
Water leakage	The piping are not properly fixed Missing gaskets	Check the piping connections
	Vent or drain valves open	Close the valves
Poor cooling performance	Vent or drain valves closed Shut-off valves (building facility) closed	Open the valves
	Inlet connection mistaken for the outlet connection and vice versa.	Check the piping connections
	Air in the coil	Open the vent valve and let the air blow out

13. Dismantling the Unit

The unit has been designed and built to ensure continuous operation.
 The working life of some of the main components depends on the maintenance that they receive.
 The unit must be dismantled if it is moved to another site, or at the end of its technical and operational life.

13.1 Safety Instructions



WARNING
 Improper operations can cause injury or death.



NOTICE
 Improper operations can cause product damage.



Read carefully the chapter *1. Safety*.
 Pay attention to the safety labels on the unit and to the safety warnings in this chapter.



ENVIRONMENT
 The unit contains substances and components hazardous for the environment (electronic components, ...).
 At the end of the useful life, when the unit is dismantled, the operation must be carried out by specialized technicians.
 The unit must be delivered to suitable centers specialized for the collection and disposal of equipment containing hazardous substances, according to the laws in force at the installation site.

13.2 Operations

Operation	Notes
1. Disconnect the electric power supply	
2. Disconnect the remote sensors	Reverse the procedure from chapter <i>10. Connections</i>
3. Remove the water piping	
4. Disassemble the unit	Reverse the procedure from chapter <i>9. Assembly</i>
5. Move away the unit	See chapter <i>8. Handling</i>
▶ If you need to keep the unit in a storehouse for reuse	See chapter <i>3.6 Storage</i>
▶ If you need to scrap the unit	Handle to authorized disposal company according to the local regulations about waste disposal.

14. Seismic application

14.1 Thermal Wall TW 200-400

The unit has been verified by calculation in accordance with IBC 2006, 2009, 2012, 2015 considering the following seismic parameters and considering the installation of the proper seismic kit:

- Importance Factor IP = 1.0 (1.5 used for structural integrity only, not functionality)
- Design Spectral Response Acceleration SDS = 1.05g for $z/h \leq 1$
- ($a_p/R_p = 0.417$; $F_p/W_p = 0.7875$)

The calculation refer to the unit stability during a seismic event due to the inertial forces caused by the seismic accelerations on the unit and his components, and it doesn't consider any loads transmitted to the unit by the building and the supporting structures during a seismic event, that could produce different displacements at the lower/upper unit connection points.

The unit structure can support a seismic event loads as an equivalent static force given by acceleration values on the unit of:

- Horizontal acceleration: 7.722 m/s²
- Vertical acceleration: 3.825 / 11.866 m/s² (Note: for the vertical acceleration 2 values are reported, as indicated by ASCE 7-10/16) with the application of the proper seismic kit.

The unit operation after a seismic event is not guarantee.



WARNING: A solid fixing system must be guarantee during the installation in order to prevent unit tilting during seismic event, evaluating any potential fixing system deformation due to the seismic event.

Note the max forces on the upper fixing structure the unit can transmit during a seismic event are reported in the table below:

Configuration	Max lateral force short side direction [N]	Max lateral force long side direction* [N]
TW 200	13.060	13.060
TW 400	26.120	26.120
TW 400 EXTENDED	32.400	32.400

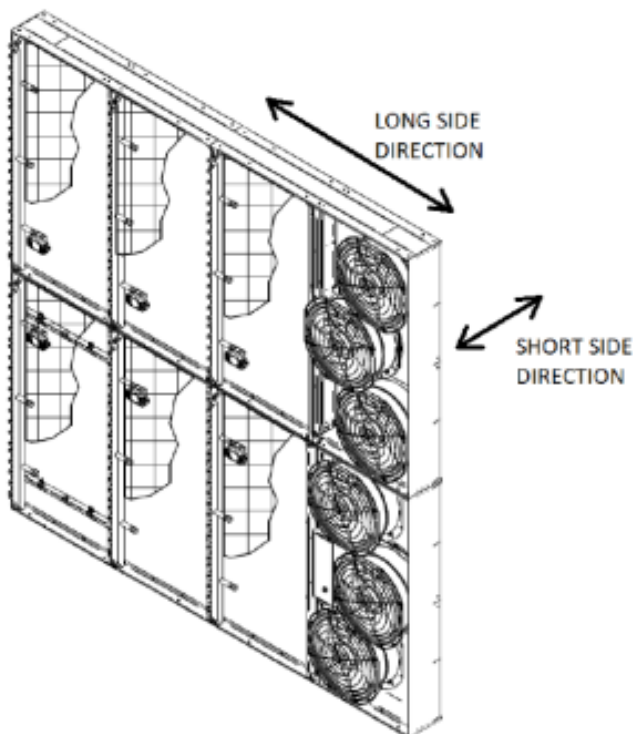

The unit must be fixed on the ground using a minimum number of anchor points as reported in the table below with a resistance force greater than the values reported. It is mandatory to use a large washer for the fixing points.

Configuration	Number of ground fixing points [#]	Max normal (traction) force (per fixing point) [N]	Max shear force (per fixing point) [N]
TW 200	10	5.720	6.120
TW 400	10	24.250	14.500
TW 400 EXTENDED	14	21.850	17.250

Note: If the unit is fixed also on the upper part to keep the vertical position, consider the same load value for the upper fixing points.

It is mandatory to check any potential unit damaging after a seismic event in order to repair before re-starting the unit.

Connections (i.e. cables/pipes/ducts...) must not apply any force or add seismic mass to the unit. Consider also to provide adequate connections for the cables, pipes, ducts to permit the deformations of the unit during a seismic event.

The unit cannot be mounted on isolators, non-rigid curb, neoprene pads, or anything that could amplify the seismic motions. The supporting structure must have adequate strength to transfer the forces to the equipment. Additionally, the supporting structure must have adequate stiffness to not amplify the equipment forces and to not overload the unit with forces coming from the building.

TW400

EVERY UNIT NEEDS FOR EACH SIDE:

- 4pcs 60031811
- 2pcs 60020926

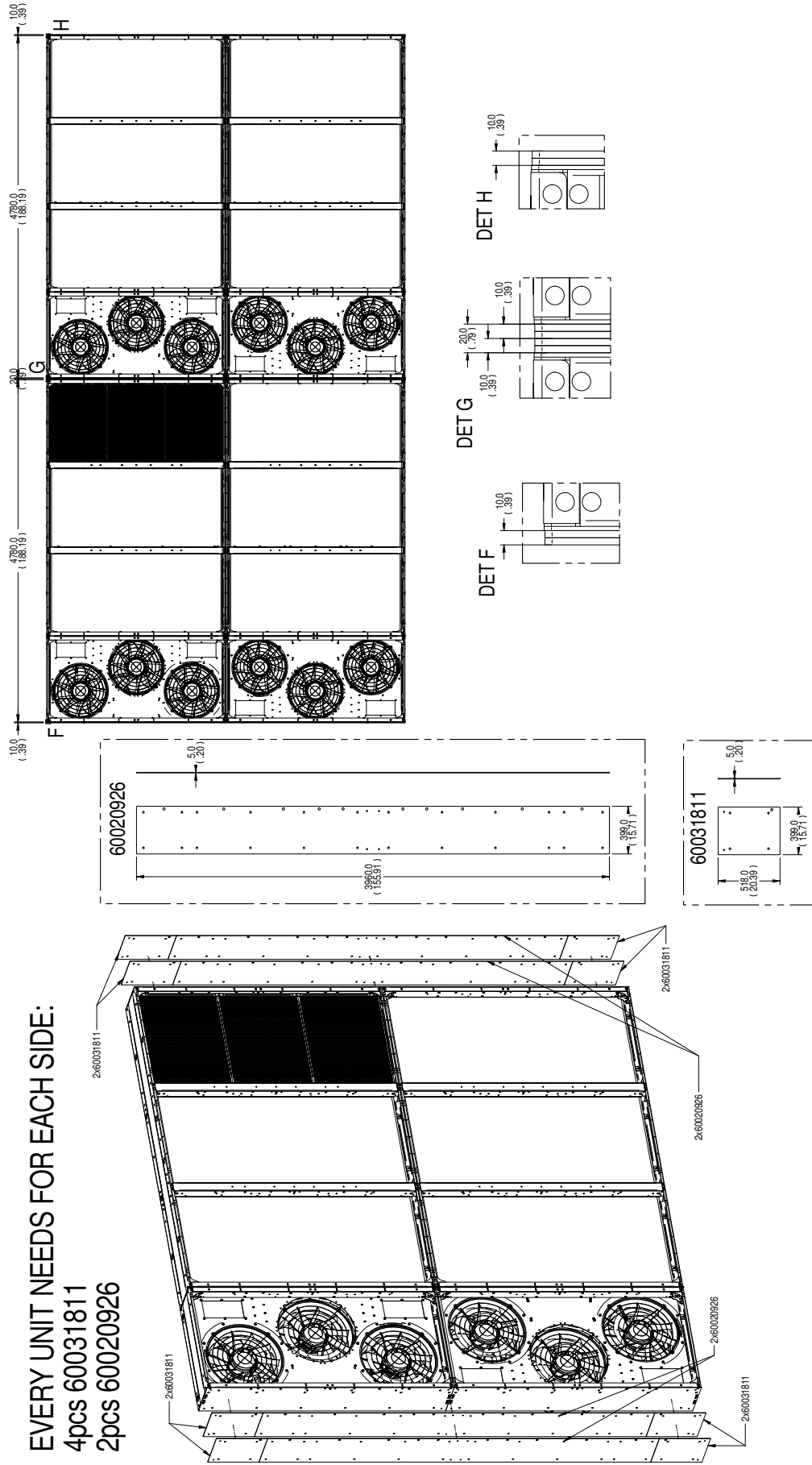

SCREWS POSITION SERVICE CORRIDOR SIDE

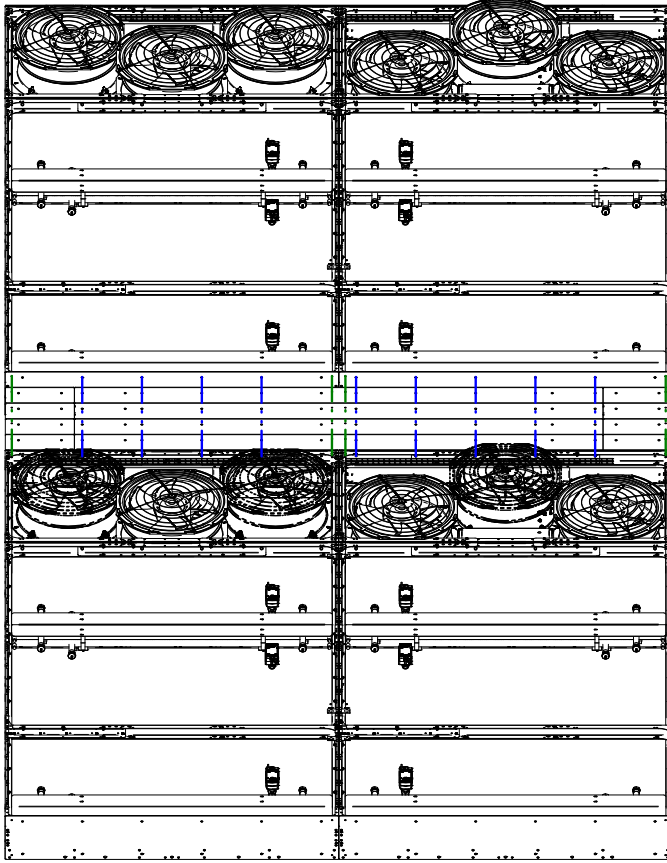

SCREWS POSITION DC SIDE

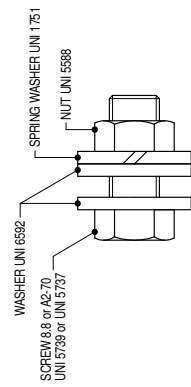
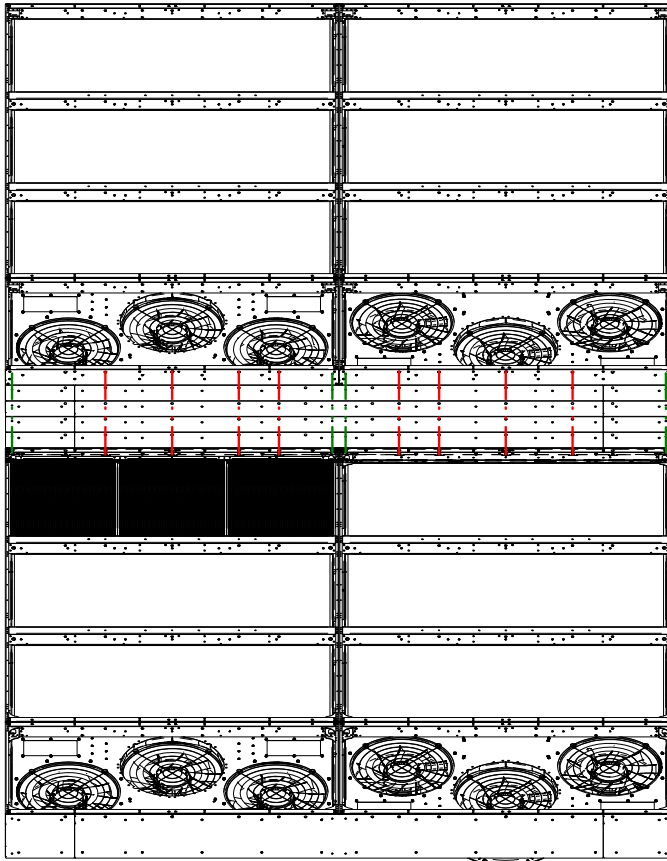

- SCREWS M8 X 50mm
- SCREWS M12 X 50mm
- SCREWS M16 X 180mm

SECT L-L

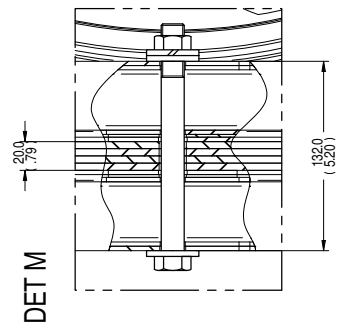
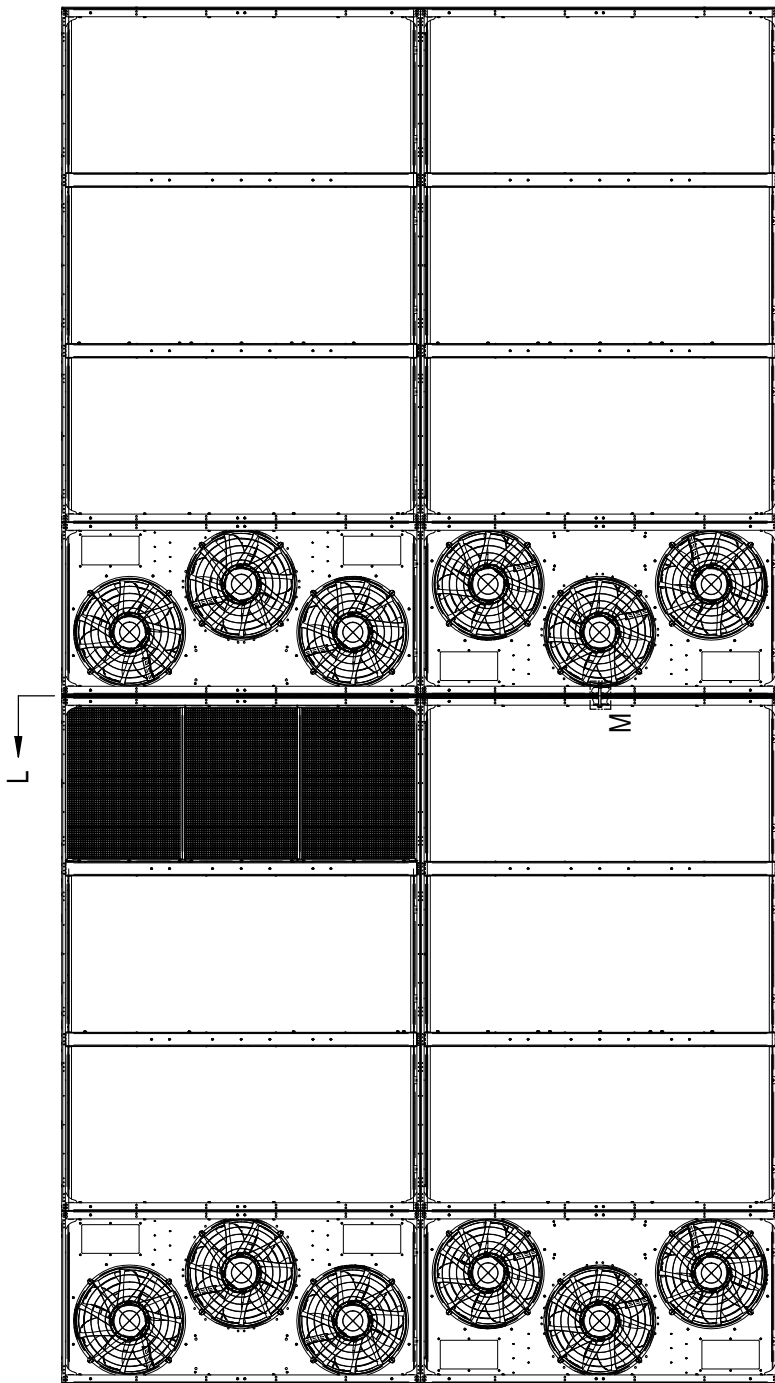
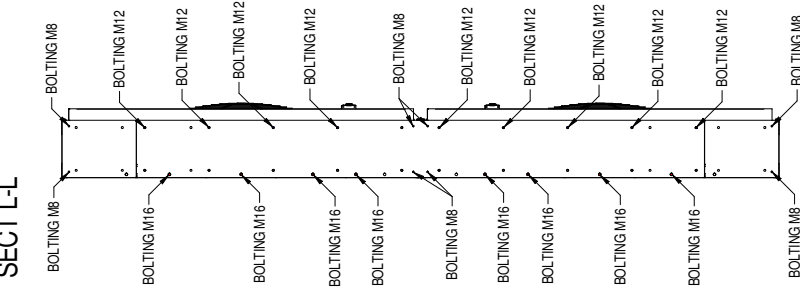

TW400 EXTENDED

EVERY "EXTENDED-UNIT" NEEDS FOR EACH SIDE:

4pcs 60031811

2pcs 60020926

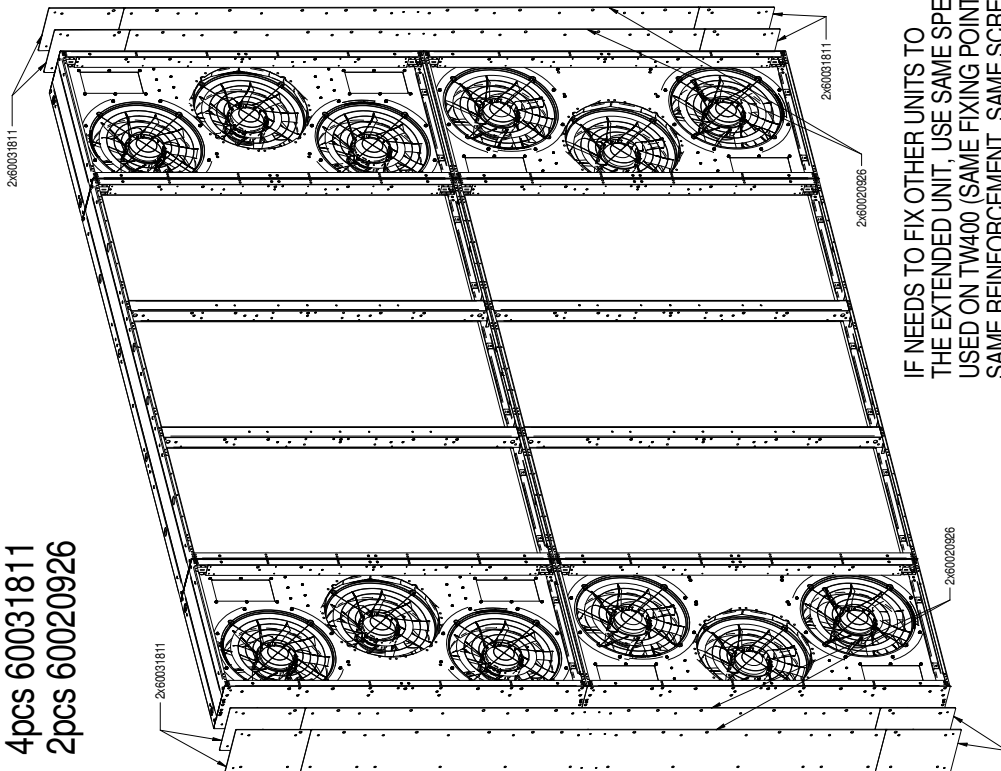
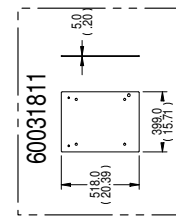
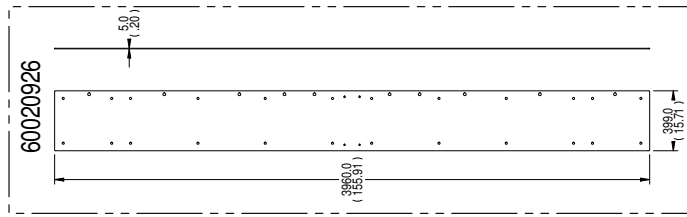
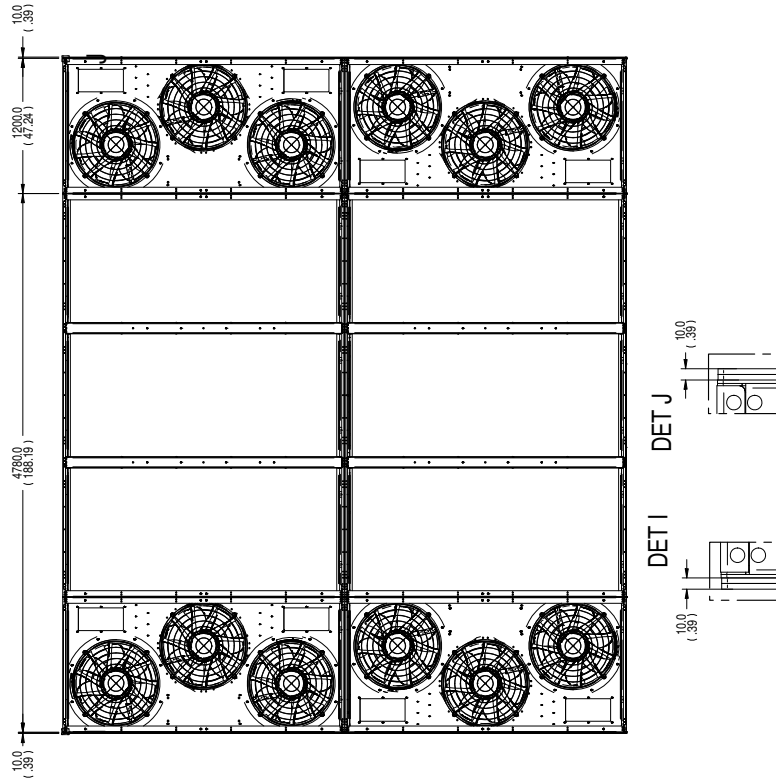

IF NEEDS TO FIX OTHER UNITS TO THE EXTENDED UNIT, USE SAME SPECIFICATIONS USED ON TW400 (SAME FIXING POINTS, SAME REINFORCEMENT, SAME SCREWS) TO BOLT IT TOGETHER

2 - Configurations details

Allowed configurations

Configuration 1



Standard

Configuration 2



Left side water coil rotated 180°

Configuration 3

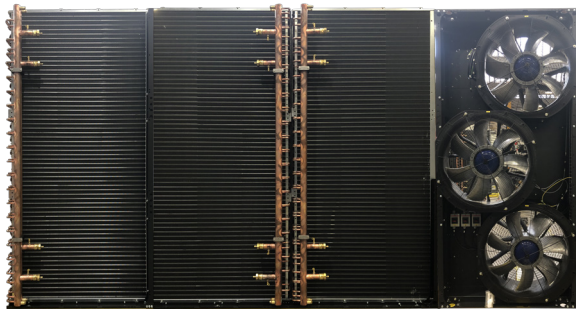

Middle water coil rotated 180°

Configuration 4



Left side and middle water coils rotated 180°

Configuration 1

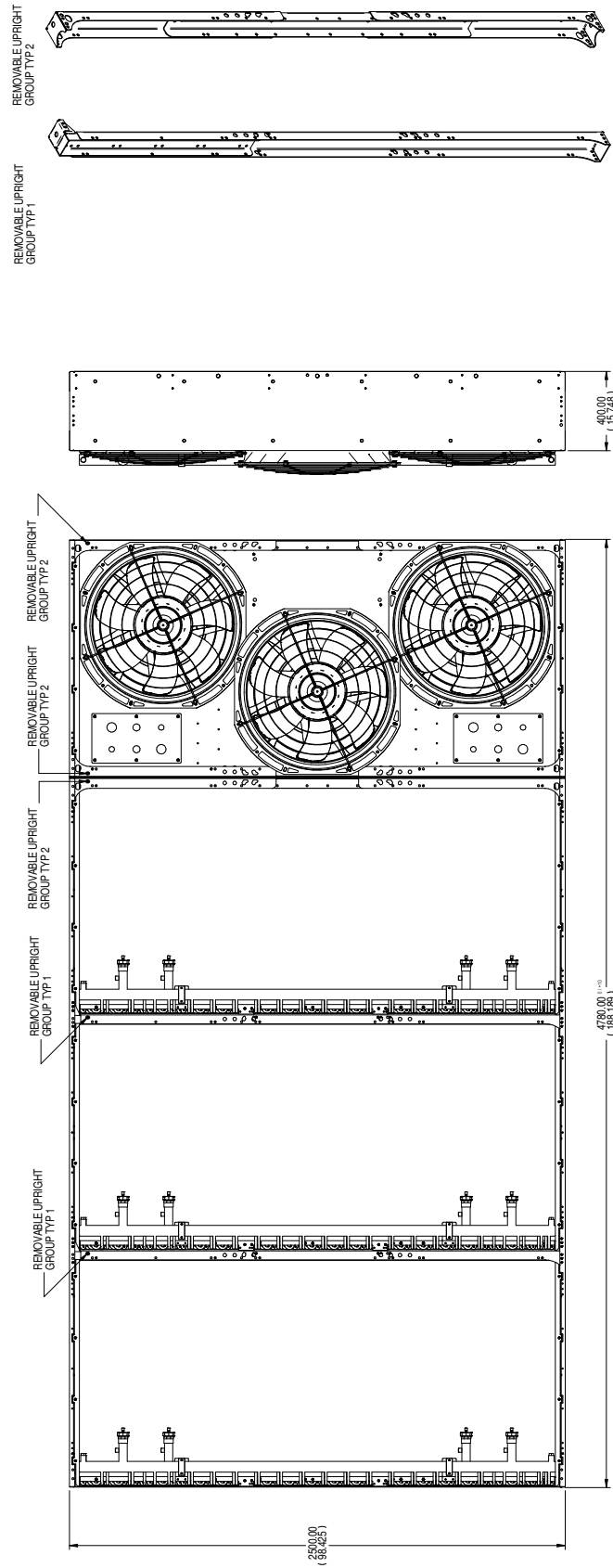

Configuration 2

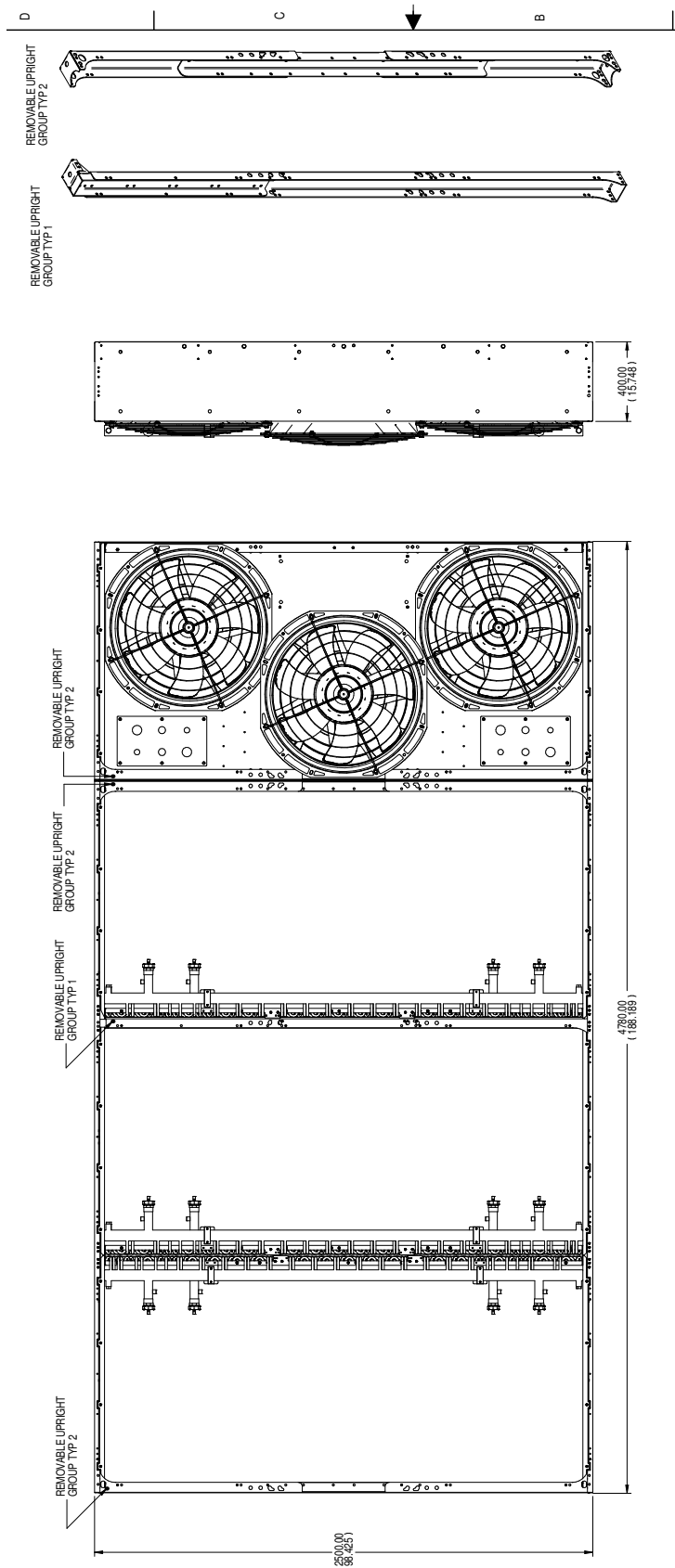

Configuration 3

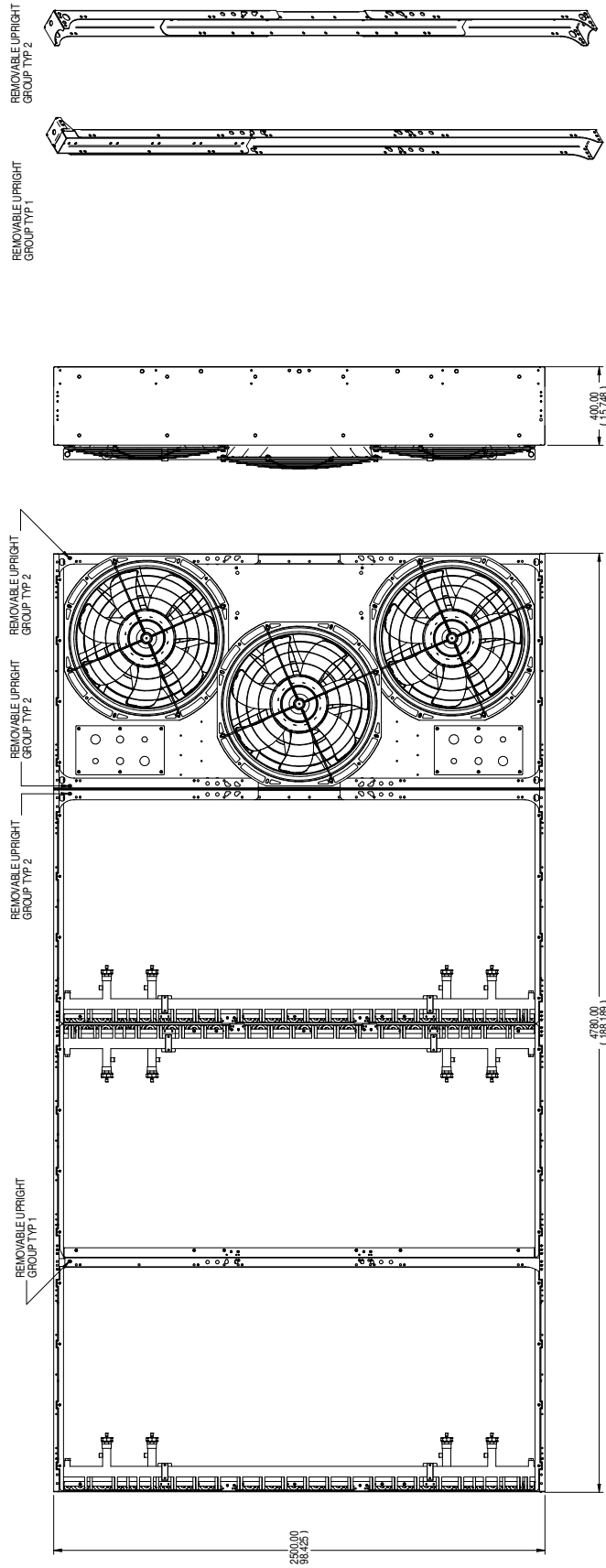

Configuration 4

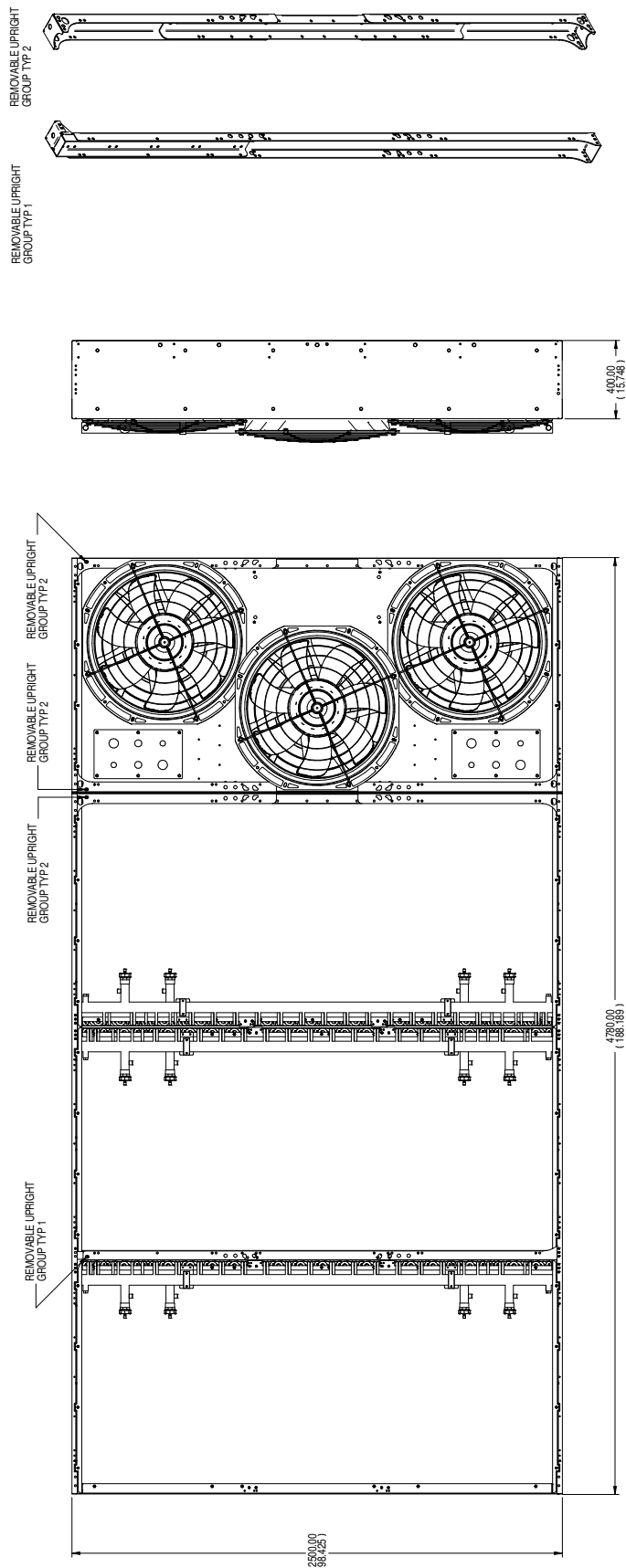

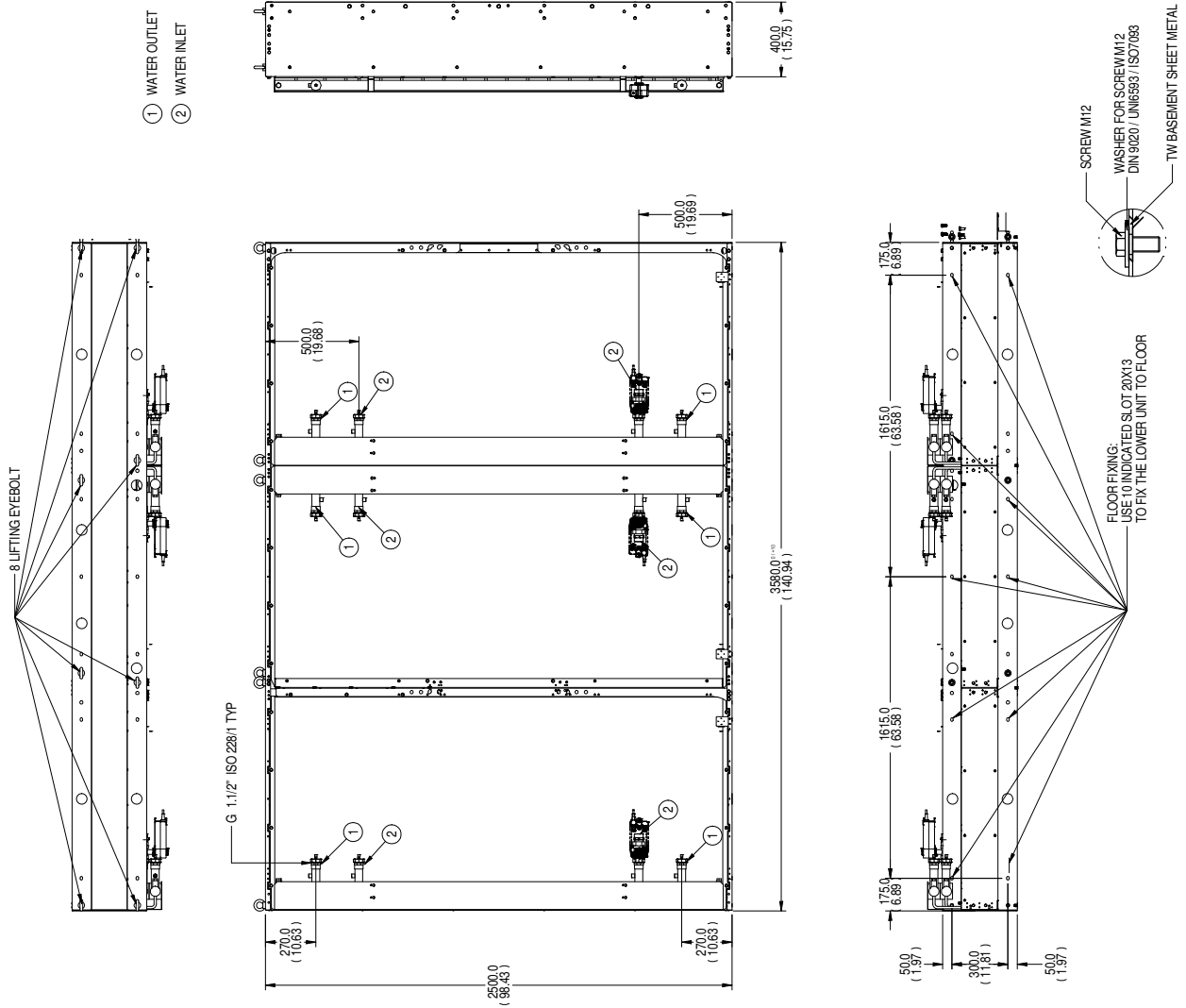
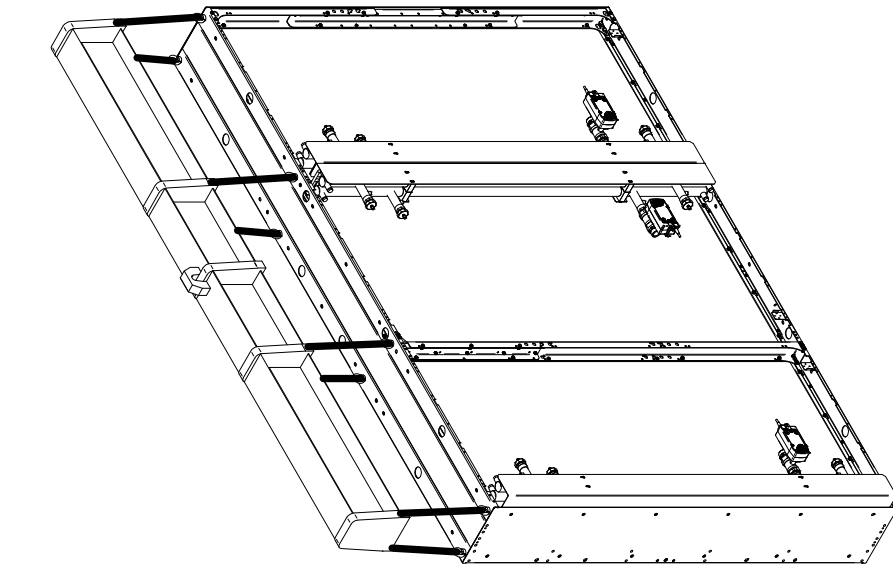

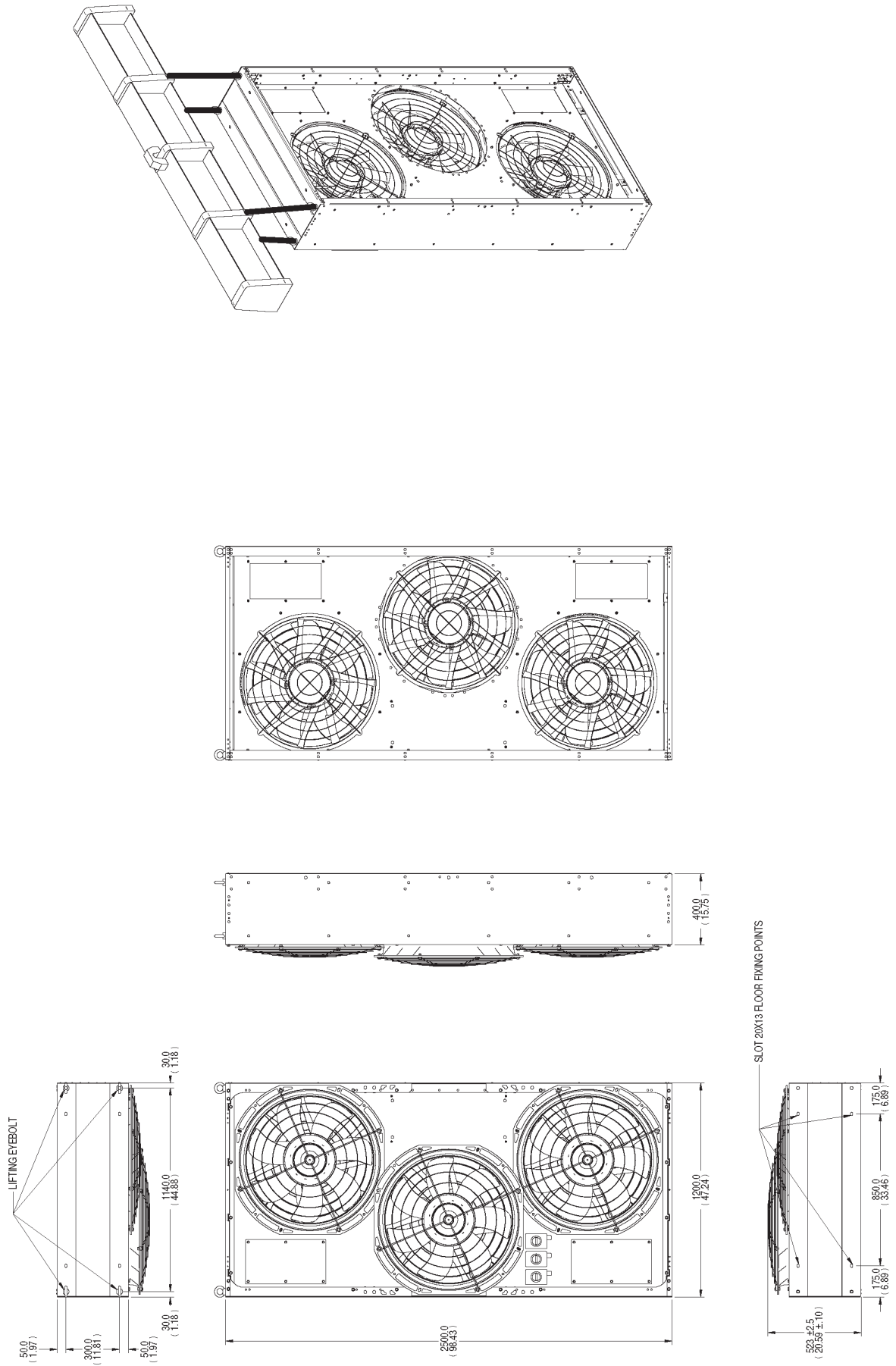

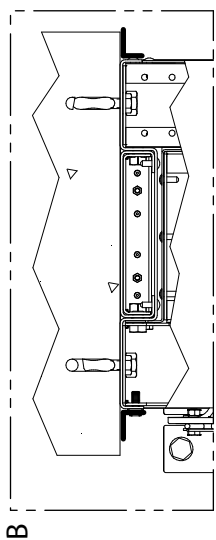

B

USE THE (5+5) SLOTS 20x13 PLACES ON THE TOP CHANNEL
 TO KEEP THE UNIT VERTICAL
 MAX SCREW HEAD HEIGHT TO ALLOW COILS REMOVAL: 15 mm
 NOTE: THESE SCREWS ARE TO KEEP THE UNIT VERTICAL,
 WITHOUT LOADING THE ROOF.
 AS ALTERNATIVE PLACE (2) ANGULARS AS SWOWN ABOVE

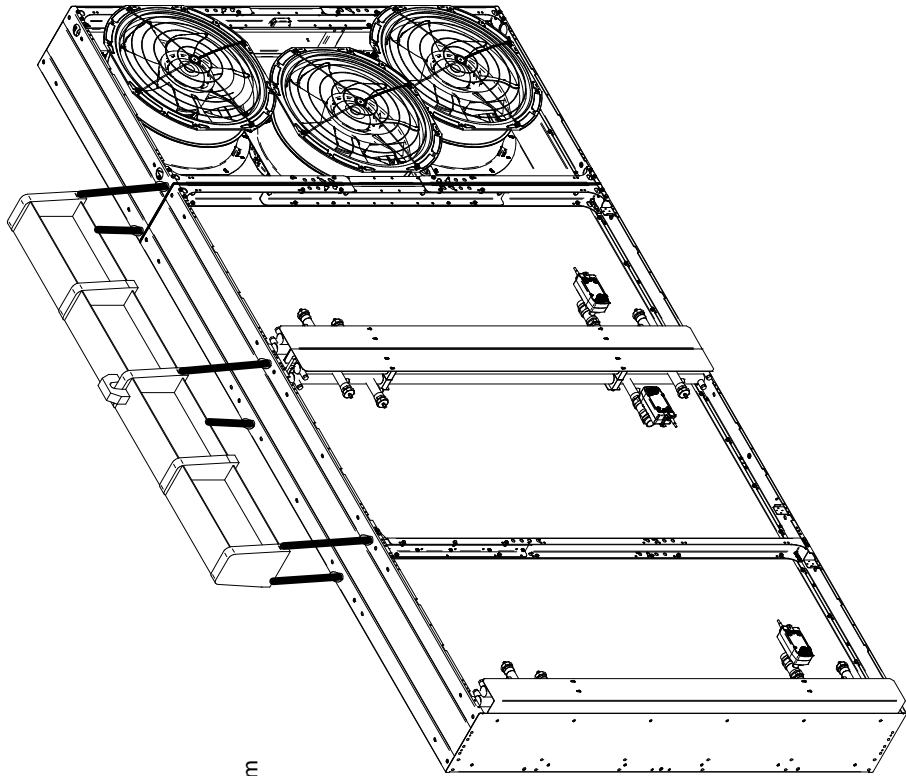

B

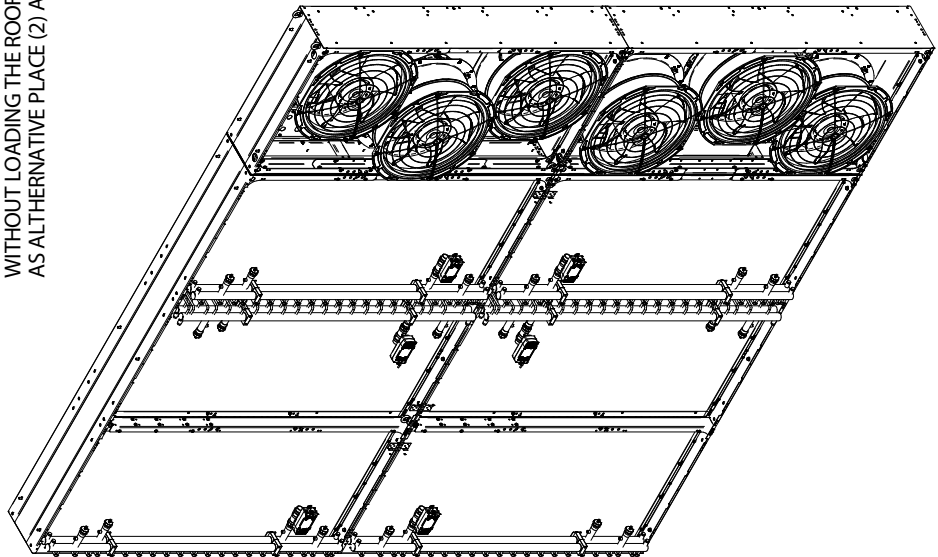
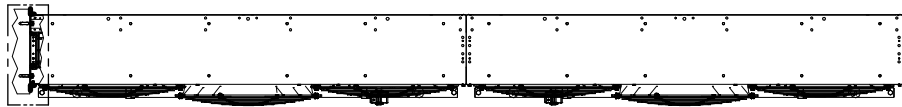

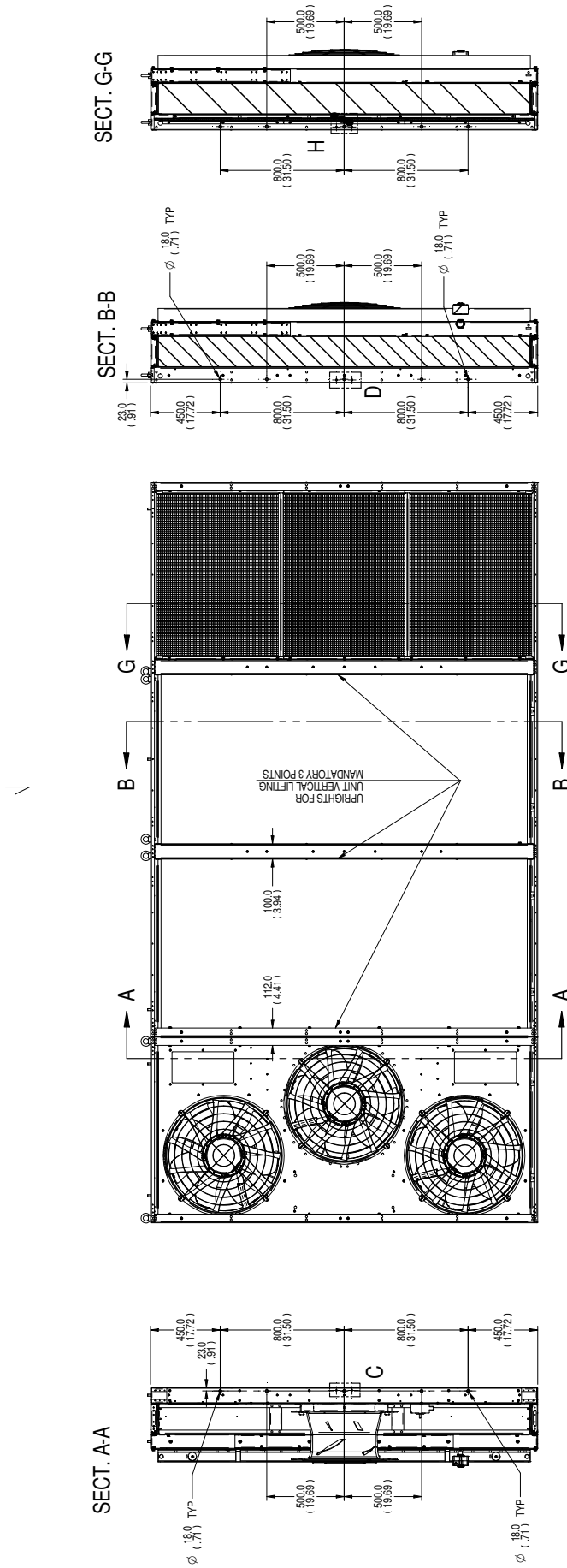

FRONTAL LIFTING:
USE 3 PIVOTS Ø16 FOR EACH PILLAR
(center to center distance:
800mm or 500mm)

DET. H

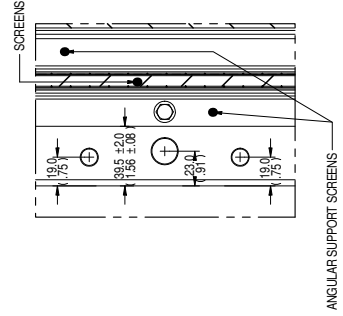

DET. D TYP
1 FOR EACH PILLAR

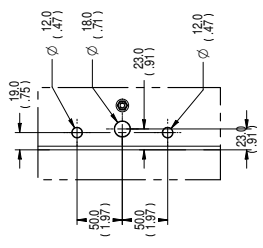

DET. C TYP
1 FOR EACH PILLAR

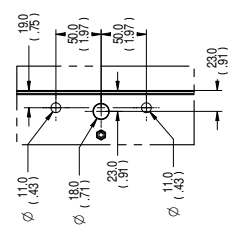

4 - Coils and connection details

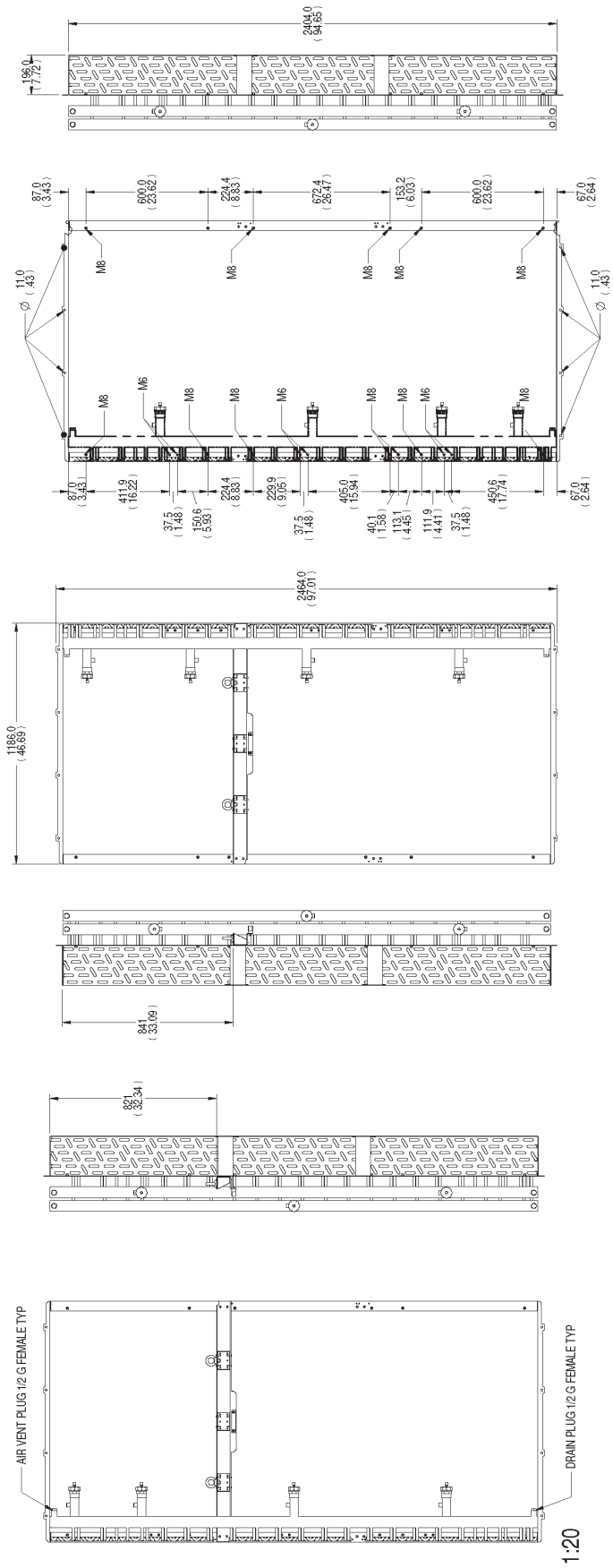

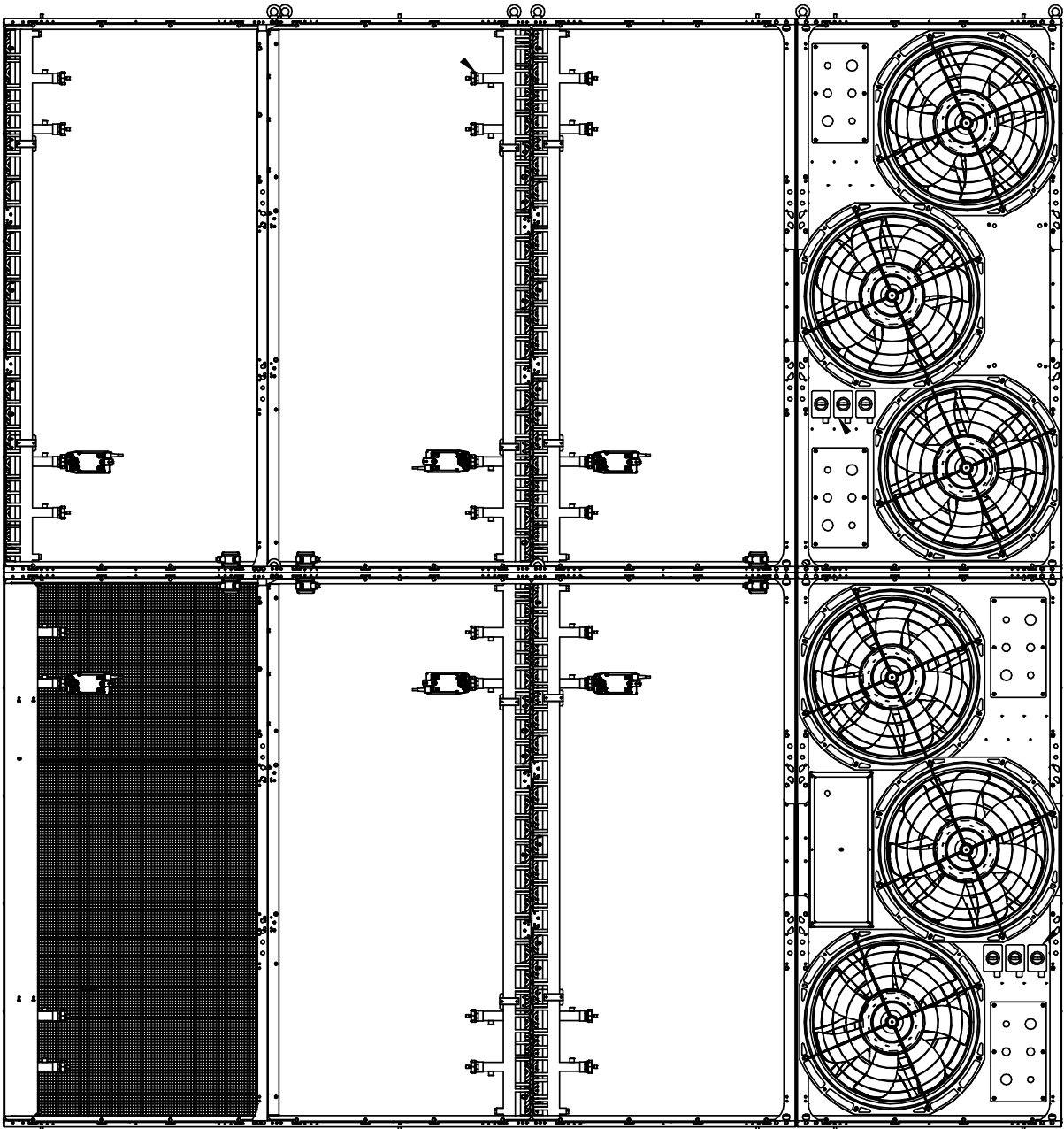

1:15

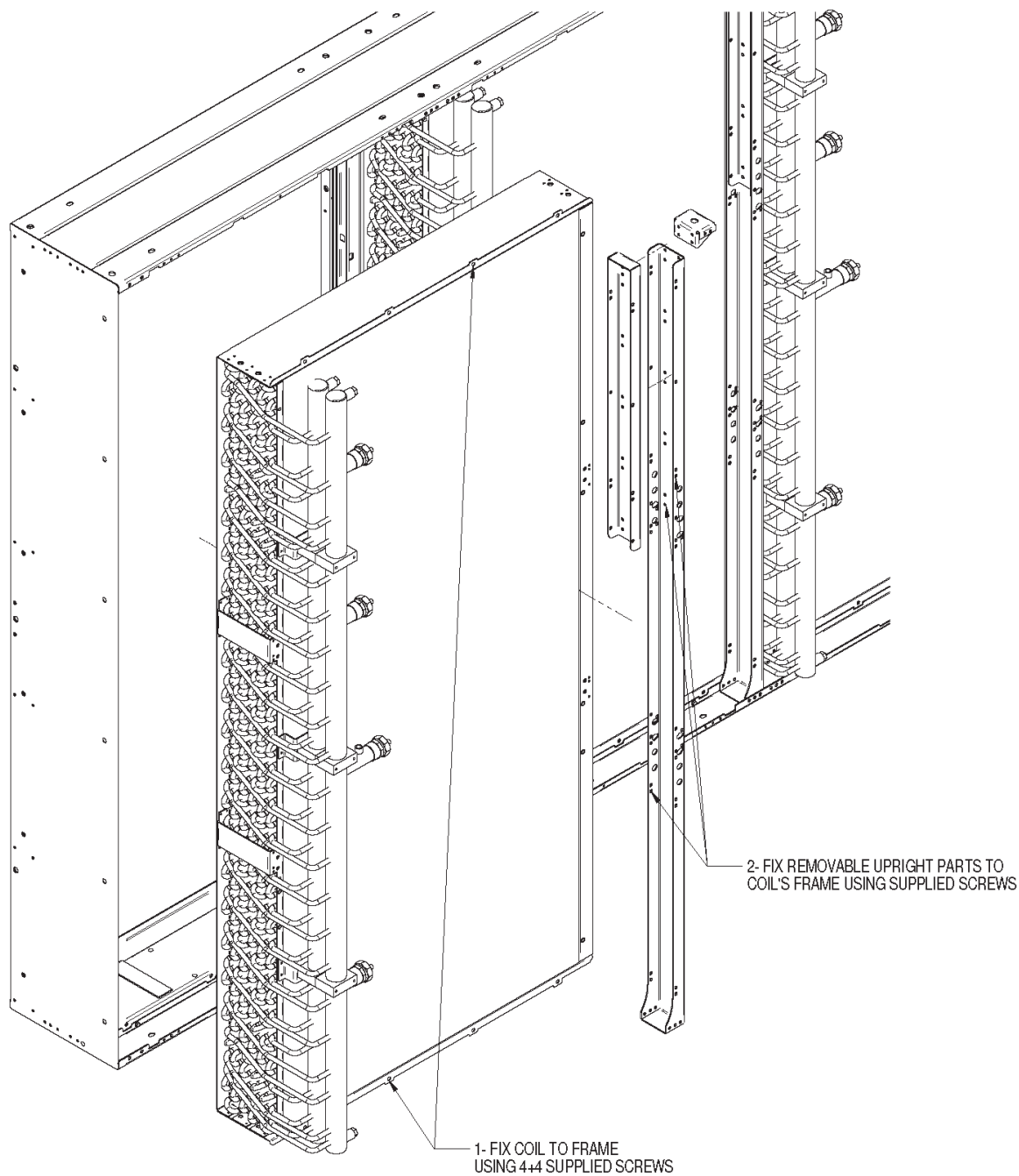



Fabbricante - Manufacturer - Hersteller - Fabricant - Fabricante Fabricante - Tillverkare - Fabrikant - Valmistaja - Produzent Fabrikant
- Κατασκευαστής - Producent
Vertiv S.r.l. - Zona Industriale Tognana
Via Leonardo da Vinci, 16/18 - 35028 Piove di Sacco - Padova (Italy)

Il Fabricante dichiara che questo prodotto è conforme alle direttive Europee:

The Manufacturer hereby declares that this product conforms to the European Union directives:

Der Hersteller erklärt hiermit, dass dieses Produkt den Anforderungen der Europäischen Richtlinien gerecht wird: Le Fabricant déclare que ce produit est conforme aux directives Européennes:

El Fabricante declara que este producto es conforme a las directivas Europeas:

O Fabricante declara que este produto está em conformidade com as directivas Europeias: Tillverkare försäkrar härmed att denna produkt överensstämmer med Europeiska Unions direktiv: De Fabrikant verklaart dat dit produkt conform de Europese richtlijnen is:

Vaimistaja vakuuttaa täten, että tämä tuote täyttää seuraavien EU-direktiivien vaatimukset: Produzent erklærer herved at dette produktet er i samsvar med EU-direktiver:

Fabrikant erklærer herved, at dette produkt opfylder kravene i EU direktiverne:

Ο Κατασκευαστής δηλώνει ότι το παρόν προϊόν είναι κατασκευασμένο σύμφωνα με τις οδηγίες της Ε.Ε.:

2006/42/EC; 2014/30/EU; 2014/35/EU; 2014/68/EU; 2011/65/EU; EU/2015/863



VertivCo.com | Vertiv - EMEA, via Leonardo Da Vinci 16/18, Zona Industriale Tognana, 35028 Piove di Sacco (PD) Italy, Tel: +39 049 9719 111, Fax: +39 049 5841 257

© 2024 Vertiv Co. All rights reserved. Vertiv, the Vertiv logo and Liebert TW are trademarks or registered trademarks of Vertiv Co. All other names and logos referred to are trade names, trademarks or registered trademarks of their respective owners. While every precaution has been taken to ensure accuracy and completeness herein, Vertiv Co. assumes no responsibility, and disclaims all liability, for damages resulting from use of this information or for any errors or omissions. Specifications are subject to change without notice.

VERTIV™ | Liebert® TW 200/400 | UM | 265867MAN_ENG | 15.03.2024