



CoolLoop Thermal Wall

Installer/User Guide

The information contained in this document is subject to change without notice and may not be suitable for all applications. While every precaution has been taken to ensure the accuracy and completeness of this document, Vertiv assumes no responsibility and disclaims all liability for damages resulting from use of this information or for any errors or omissions.

Vertiv recommends installing a monitored fluid detection system that is wired to activate the automatic closure of field-installed coolant fluid supply and return shut off valves, where applicable, to reduce the amount of coolant fluid leakage and consequential equipment and building damage.

Refer to local regulations and building codes relating to the application, installation, and operation of this product. The consulting engineer, installer, and/or end user is responsible for compliance with all applicable laws and regulations relating to the application, installation, and operation of this product.

The products covered by this instruction manual are manufactured and/or sold by Vertiv. This document is the property of Vertiv and contains confidential and proprietary information owned by Vertiv. Any copying, use, or disclosure of it without the written permission of Vertiv is strictly prohibited.

Names of companies and products are trademarks or registered trademarks of the respective companies. Any questions regarding usage of trademark names should be directed to the original manufacturer.

Technical Support Site

If you encounter any installation or operational issues with your product, check the pertinent section of this manual to see if the issue can be resolved by following outlined procedures.

Visit <https://www.vertiv.com/en-us/support/> for additional assistance.

TABLE OF CONTENTS

1 Important Safety Instructions	1
2 Nomenclature and Components	7
2.1 Vertiv™ CoolLoop Thermal Wall Model Number Nomenclature	7
2.2 Component Location	11
2.3 Vertiv™ CoolLoop Thermal wall Physical Data	12
3 Pre-Installation Preparation and Guidelines	15
3.1 Planning Dimensions	15
3.2 Connections and System Setup	16
3.3 Operating Conditions	16
3.3.1 Humidification Control	16
3.3.2 Storage conditions	17
3.4 Shipping Dimensions and Unit Weights	17
3.5 Site Preparation	17
3.5.1 Preparing a Concrete Slab	18
4 Equipment Inspection and Handling and Installation	19
4.1 Packaging Material	19
4.2 Handling the Modules While Packaged	20
4.3 Unpacking the Modules	20
4.3.1 Filter and Rack Removal	20
4.4 Preparing for Assembly	21
4.4.1 Top Module Prep on Skid	21
4.4.2 Customer Piping Installation Validation	22
4.4.3 Top Module—Venting the Inert Gas Holding Charge	26
4.4.4 Bottom Module Prep on Skid	26
4.4.5 Bottom Module—Venting the Inert Gas Holding Charge	27
4.4.6 Removing Lag Screw Shipping Fasteners	29
4.5 Assembly of Top and Bottom Modules	31
4.6 Final Installation	32
4.7 Damper Installation (Optional)	34
5 Electrical Connections	35
5.1 Low Voltage Liqui-Tech Sensor Location	36
5.2 Air Temperature Sensor Location (Data Hall Side Only)	39
6 Piping Requirements	41
6.1 Drain Fluid Connections	42
6.1.1 Field Installed, Gravity Drain Line Requirements	42
6.2 Chilled Water Loop Piping Guidelines	43
6.2.1 Flanged Connections	45

6.2.2 Grooved Connections	46
6.2.3 Leak Checking for Unit and Field Installed Piping	49
7 Checklist for Completed Installation	51
7.1 Moving and Placing Equipment	51
7.2 Electrical Installation Checks	51
7.3 Piping Installation Checks	51
7.4 Other Installation Checks	51
8 Initial Start Up Checks and Commissioning Procedure For Warranty Inspection	53
9 Maintenance	55
9.1 Filters	56
9.1.1 Replacing the Filters	56
9.2 Fan Maintenance	57
9.2.1 Fan Assembly Troubleshooting	57
9.2.2 Fan Impellers	58
9.2.3 Backdraft Barrier Kits	59
9.2.4 Removing Fan Assembly	59
9.3 Condensate Drain System Maintenance	65
9.3.1 Condensate Drain	65
9.3.2 Condensate Pump	65
9.3.3 Coil Drain Plug	65
9.3.4 Water Valves Actuator Maintenance	66
9.3.5 Optional Damper Actuator Maintenance	66
9.3.6 Facility Fluid and Piping Maintenance	66
9.3.7 Glycol Solution Maintenance	67
10 Preventive Maintenance Checklist	69
Appendices	73
Appendix A: Technical Support and Contacts	73
Appendix B: Flange Specifications	75
Appendix C: Submittal Drawings	77
Appendix D: Seismic Application	79
Appendix E: Guide Specifications	81

1 Important Safety Instructions

SAVE THESE INSTRUCTIONS

This manual contains important safety instructions that should be followed during the installation and maintenance of the Vertiv™ CoolLoop Thermal Wall. Read this manual thoroughly before attempting to install or operate this unit.

Only qualified personnel should move, install, or service this equipment.

Adhere to all warnings, cautions, notices and installation, operating and safety instructions on the unit and in this manual. Follow all installation, operation and maintenance instructions and all applicable national and local building, electrical and plumbing codes.



WARNING! Arc flash and electric shock hazard. Open all local and remote electric power supply disconnect switches, verify with a voltmeter that power is Off and wear appropriate, OSHA-approved personal protective equipment (PPE) per NFPA 70E before working within the electric control enclosure. Failure to comply can cause serious injury or death. Customer must provide earth ground to unit, per NEC, CEC and local codes, as applicable. Before proceeding with installation, read all instructions, verify that all the parts are included and check the nameplate to be sure the voltage matches available utility power. The Vertiv™ iCOM™ controller does not isolate power from the unit, even in the “Unit Off” mode. Some internal components require and receive power even during the “Unit Off” mode of the controller. The only way to ensure that there is NO voltage inside the unit is to install and open a remote disconnect switch. Refer to unit electrical schematic. Follow all local codes.



WARNING! Risk of electric shock. Can cause equipment damage, injury or death. Open all local and remote electric power supply disconnect switches and verify with a voltmeter that power is off before working within any electric connection enclosures. Installation, service, and maintenance work must be performed only by properly trained and qualified personnel and in accordance with applicable regulations and manufacturers’ specifications. Opening or removing the covers to any equipment may expose personnel to lethal voltages within the unit even when it is apparently not operating and the input wiring is disconnected from the electrical source.



WARNING! Risk of electric shock. Can cause serious injury or death. The Vertiv™ iCOM™ microprocessor does not isolate power from the unit, even in the "Unit Off" mode. Some internal components require and receive power even during the "unit off" mode of the Vertiv™ iCOM™ control. Open all local and remote electric power disconnect switches and verify with a voltmeter that power is Off before working on any component of the system.



WARNING! Risk of electric shock. Can cause injury or death. Open all local and remote electric power supply disconnect switches and verify that power is Off with a voltmeter before working within the condensate pump electrical connection enclosure. The Vertiv™ iCOM™ does not isolate power from the unit, even in the “Unit Off” mode. Some internal components require and receive power even during the “Unit Off” mode of the Vertiv™ iCOM™.



WARNING! Risk of improper moving. Can cause equipment damage, injury, or death. Use only lifting equipment that is rated for the unit weight by an OSHA-certified rating organization.



WARNING! Risk of improper moving, lifting, or handling of the unit. Can cause equipment damage, injury or death. Read all of the following instructions and verify that all lifting and moving equipment is rated for the weight of the unit before attempting to move, lift, remove packaging from or prepare the unit for installation. Shipping weights and unit weights are listed in 20000779 for CA60 and 20000252 for CA80 unit.



WARNING! Risk of top-heavy unit falling over. Improper handling can cause equipment damage, injury or death. The center of gravity varies depending on the unit size and selected options. Shipping weights and unit weights are specified in 20000779 for CA60 and 20000252 for CA80 unit.



WARNING! Risk of improper wire sizing/rating and loose electrical connections. Can cause overheated wire and electrical connection terminals resulting in smoke, fire, equipment and building damage, injury or death. Use correctly sized copper wire only and verify that all electrical connections are tight before turning power On. Check all electrical connections periodically and tighten as necessary.



WARNING! Risk of contact with high speed rotating fan blades. Can cause serious injury or death. Open all local and remote electric power supply disconnect switches, verify with a voltmeter that power is off, and verify that all fan blades have stopped rotating before working in the unit cabinet or on the fan assembly. If control voltage is applied, the fan motor can restart without warning after a power failure. Do not operate the unit with any or all cabinet panels removed.



WARNING! Risk of improper wiring, piping, moving, lifting and handling. Can cause equipment damage, serious injury or death. Installation and service of this equipment should be done only by qualified personnel who have been specially trained in the installation of air conditioning equipment and who are wearing appropriate, OSHA-approved PPE.



CAUTION: Risk of contact with sharp edges, splinters, and exposed fasteners. Can cause injury. Only properly trained and qualified personnel wearing appropriate, OSHA-approved PPE should attempt to move, lift, remove packaging from or prepare the unit for installation.



CAUTION: Risk of exposure to harmful noise levels. Can cause hearing injury or loss. Depending on the installation and operating conditions, a sound pressure level greater than 70 dB(A) may arise. Take appropriate technical safety measures. Operating personnel must wear appropriate, OSHA-approved PPE and observe all appropriate hearing-protection safety requirements.



CAUTION: Risk of contact with hot surfaces. Can cause injury. The fan motor and some electrical components are extremely hot during unit operation. Allow sufficient time for them to cool to a touch-safe temperature before working within the unit cabinet. Use extreme caution and wear appropriate, OSHA-approved PPE when working on or near hot components.



CAUTION: Risk of improper piping installation, leak checking, fluid chemistry, and fluid maintenance can cause equipment damage and personal injury. Installation and service of this equipment should be done only by qualified personnel who are wearing appropriate, OSHA-approved PPE.

NOTICE

Risk of improper power supply connection. Can cause equipment damage and loss of warranty coverage.

Prior to connecting any equipment to a main or alternate power source (for example: backup generator systems) for start up, commissioning, testing, or normal operation, ensure that these sources are correctly adjusted to the nameplate voltage and frequency of all equipment to be connected. In general, power source voltages should be stabilized and regulated to within $\pm 10\%$ of the load nameplate nominal voltage. Also, ensure that no three-phase sources are single phased at any time.

NOTICE

Risk of piping-system corrosion and freezing fluids. Can cause leaks resulting in equipment and very expensive building damage. Cooling coils and piping systems are at high risk of freezing and premature corrosion. Fluids in these systems must contain the proper antifreeze and inhibitors to prevent freezing and premature coil and piping corrosion. The water or water/glycol solution must be analyzed by a competent local water treatment specialist before start up to establish the inhibitor and antifreeze solution requirement and at regularly scheduled intervals throughout the life of the system to determine the pattern of inhibitor depletion.

The complexity of water/glycol solution condition problems and the variations of required treatment programs make it extremely important to obtain the advice of a competent and experienced water treatment specialist and follow a regularly scheduled coolant fluid system maintenance program.

Water chemistry varies greatly by location, as do the required additives, called inhibitors, that reduce the corrosive effect of the fluids on the piping systems and components. The chemistry of the water used must be considered, because water from some sources may contain corrosive elements that reduce the effectiveness of the inhibited formulation. Sediment deposits prevent the formation of a protective oxide layer on the inside of the coolant system components and piping. The water/coolant fluid must be treated and circulating through the system continuously to prevent the buildup of sediment deposits and or growth of sulfate reducing bacteria.

Proper inhibitor maintenance must be performed in order to prevent corrosion of the system. Consult glycol manufacturer for testing and maintenance of inhibitors.

Commercial ethylene glycol, when pure, is generally less corrosive to the common metals of construction than water itself. It will, however, assume the corrosivity of the water from which it is prepared and may become increasingly corrosive with use if not properly inhibited.

We recommend installing a monitored fluid detection system that is wired to activate the automatic-closure of field-installed coolant-fluid supply and return shutoff valves to reduce the amount of coolant-fluid leakage and consequential equipment and building damage. The shutoff valves must be sized to close off against the maximum coolant-fluid system pressure in case of a catastrophic fluid leak.

NOTICE

Risk of frozen pipes and corrosion from improper coolant mixture. Can cause water leaks resulting in equipment and building damage.

When the cooling unit or piping may be exposed to freezing temperatures, charge the system with the proper percentage of glycol and water for the coldest design ambient temperature. Automotive antifreeze is unacceptable and must NOT be used in any glycol fluid system. Use only HVAC glycol solution that meets the requirements of recommended industry practices. Do not use galvanized pipe.

NOTICE

Risk of no flow condition. Can cause equipment damage.

Do not leave the water/coolant fluid supply circuit in a no-flow condition. Idle fluid allows the collection of sediment that prevents the formation of a protective oxide layer on the inside of tubes. Keep unit switched On and water/coolant fluid supply circuit system operating continuously.

NOTICE

Risk of clogged or leaking drain lines and leaking water supply lines. Can cause equipment and building damage.

This unit requires a water drain connection. Drain lines must be inspected at start-up and periodically, and maintenance must be performed to ensure that drain water runs freely through the drain system and that lines are clear and free of obstructions and in good condition with no visible sign of damage or leaks. This unit may also require an external water supply to operate.

Improper installation, application and service practices can result in water leakage from the unit. Water leakage can result in catastrophic and expensive building and equipment damage and loss of critical data center equipment.

Do not locate unit directly above any equipment that could sustain water damage.

We recommend installing a monitored fluid detection system to immediately discover and report coolant-fluid system and condensate drain line leaks.

NOTICE

Risk of doorway/hallway interference. Can cause unit and/or structure damage. The unit may be too large to fit through a doorway or hallway while on or off skid. Measure the unit and passageway dimensions, and refer to the installation plans prior to moving the unit to verify clearances.

NOTICE

Risk of damage from forklift. Can cause unit damage. Keep tines of the forklift level and at a height suitable to fit below the skid and/or unit to prevent exterior and/or underside damage.

NOTICE

Risk of improper storage. Can cause unit damage.

Keep the unit upright, indoors and protected from dampness, freezing temperatures and contact damage.

NOTICE

The Vertiv™ CoolLoop Thermal Wall is required to be installed only in locations not accessible to the general public. Installation, service, and maintenance work must be performed only by properly trained and qualified personnel and in accordance with applicable regulations and manufacturers' specifications.

NOTICE

The Vertiv™ CoolLoop Thermal Wall shall be installed and connected in accordance with national wiring regulations.

This page intentionally left blank

2 Nomenclature and Components

This section describes the model number for Vertiv™ CoolLoop Thermal Wall units and components.

2.1 Vertiv™ CoolLoop Thermal Wall Model Number Nomenclature

2.1 above describes each digit of the configuration number. The Vertiv™ CoolLoop Thermal Wall system consists of a bottom and top module. There is one unique configuration number for the system, while there is a unique model number for the bottom module and another unique model number for the top module.

The 14 digit Model Number is comprised of the first 10 digits (digits 1-10) and the last 4 digits (configuration digits 37-40) of the Configuration Number.

An example of a CoolLoop Thermal Wall Configuration Number would be:

CA608AF1AB02081SSDBFP0000P0PC0000000A903

An example of the model numbers for the CoolLoop Thermal Wall would be:

Bottom Module Model Number: CA608AF1ABA903

Top Module Model Number: CA608AF1ATA903

Table 2.1 Configuration Number Breakdown Digits 1 to 20 (example)

1	2	3	4	5	6	7	8	9	10	11	12	13	14	15	16	17	18	19	20
C	A	6	0	8	A	F	1	A	B	0	2	0	8	1	S	S	D	B	F

Table 2.2 Configuration Number Breakdown Digits 21 to 40 (example)

21	22	23	24	25	26	27	28	29	30	31	32	33	34	35	36	37	38	39	40
P	0	0	0	0	P	0	P	C	0	0	0	0	0	0	0	A	9	0	3

Table 2.3 Model Number Breakdown (example)

1	2	3	4	5	6	7	8	9	10	11	12	13	14
C	A	6	0	8	A	F	1	A	B	A	9	0	3

Table 2.4 Vertiv™ CoolLoop Thermal Wall Configuration Number Digit Definitions

Digit	Description
1, 2—Vertiv™ CoolLoop Thermal Wall	CA
3, 4—Model	60 80
5—Coil Rows	4 = 4 Row 6 = 6 Row 8 = 8 Row S = Smart 14-16F Fluid Delta N = Next Generation 18-20F Fluid Delta
6—Fan Type	A = High Airflow, High Efficiency Fan C = High Airflow, High Efficiency Fan + Integrated THD Mitigation U = Ultra Performance V = Ultra Performance + Integrated THD Mitigation
7—Customer Connection Type	F = Flanged B = Brazed V = Grooved
8—Valve Type	1 = 2-way fail in place 4 = 2-way fail open 5 = 2-way fail closed G = 2-way PICV fail-in-place H = 2-way PICV fail-open J = 2-way PICV fail-closed
9—Power Supply	A = 460/3/60 B = 575/3/60 2 = 380/3/60 M = 380-415/3/50
10—Module	B = Bottom (base) module T = Top module
11—	0 = Placeholder
12—Display/Microprocessor Control	2 = Vertiv™ iCOM™ (high definition)
13—	0 = Placeholder
14—Air Filter	8 = 4" MERV 8 + Filter Clog switch 9 = 4" MERV 11 + Filter Clog switch 0 = None
15—Coil	1 = Non-coated coils
16—Seismic	0 = None S = Seismic (IBC Sds 0.75)

Table 2.4 Vertiv™ CoolLoop Thermal Wall Configuration Number Digit Definitions (continued)

Digit	Description
	C = Seismic (IBC Sds 2.5)
17—High Voltage Options	L = Locking Disconnect + Quick Start Enabled C = Locking Disconnect + Capacitive Buffer + Quick Start Enabled R = Dual Locking Disconnect with Reversing Starter + Quick Start Enabled S = Dual Locking Disconnect with Reversing Starter + Capacitive Buffer + Quick Start Enabled
18—Options Packages	O = None L = Low voltage terminal package D = Low voltage terminal package plus remote humidifier contact
19—Monitoring	B = Base Comms and Connectivity
20—Sensors	O = None S = Smoke H = High temperature F = Smoke and high temperature
21—Packaging	P = Domestic packaging C = Export packaging
22—Water Sensor	O = None W = Water Temperature Sensor = In/Out
23 - 25	O = Placeholder
26	O = None P = Power Meter
27—Additional Monitoring Options	O = None L = LT460 (Mounted and Installed)
28—Additional Sensors	O = None P = Static Pressure Fan Control (Mounted and Installed)
29—Condensate Pump	O = None C = Condensate pump
30—Internal/External Sensor	O = None 3 = 30 ft (9.1 m) Remote temperature and humidity sensor 6 = 60 ft (18.3 m) Remote temperature and humidity sensor 9 = 90 ft (27.4 m) Remote temperature and humidity sensor 2 = 120 ft (36.6 m) Remote temperature and humidity sensor 5 = 150 ft (45.7 m) Remote temperature and humidity sensor
31—Motorized Damper	O = None D = Motorized Damper Kit and controls

Table 2.4 Vertiv™ CoolLoop Thermal Wall Configuration Number Digit Definitions (continued)

Digit	Description
32-36	0 = Placeholder
37—Configuration Code	A = No SFA S = SFA
38-40—Factory Configuration Number	Factory configuration code

2.2 Component Location

The unit component locations are described in the submittal documents included in the [Submittal Drawings](#) on page 77 .

The following table lists the relevant documents by number and title.

Table 2.5 Component Location Drawings

Document Number	Title
20000778	Component Location Diagram with High Airflow/High Efficiency Fan
20000251	CA80 Component Location Diagram

2.3 Vertiv™ CoolLoop Thermal wall Physical Data

Table 2.6 Physical Data

Model Number	Without THD	CA604A		CA606A		CA608A		CA80SA		CA80NA		CA80SU		CA80NU	
	With Integrated THD (optional)	CA604C	CA606C	CA608C	CA80SC	CA80NC	CA80SV	CA80NV							
Fan Data - EC Fans															
Coil Rows		4	6	8	6	6	6	6							
Fan Type		High Airflow, High Efficiency				High Airflow, High Efficiency				Ultra Performance					
Nominal Air Volume CFM (CMH) @ 0.2" (50 Pa) ESP with MERV8 filters		45,000 (76,455)				60,000 (101,940)									
Coil Face Velocity FPM (m/s)		445 (2.26)				451 (2.29)									
Maximum Air Volume CFM (CMH) @ 0.2" (50 Pa) ESP with MERV8 filters		64,000 (108,737)	62,400 (106,018)	60,800 (103,300)	79,100 (134,392)	78,500 (133,372)	87,300 (148,324)	86,700 (147,304)							
Coil Face Velocity FPM (m/s)		632 (3.21)	617 (3.13)	601 (3.05)	594 (3.02)	590 (3.00)	656 (3.33)	652 (3.31)							
Fan Motor, Maximum hp (kW), each		4.96 (3.7)				4.96 (3.7)				6.17 (4.6) without THD / 6.44 (4.8) with integrated THD					
Quantity of Fan Motors		6				8									
Chilled Water Coil															
Face Area ft ² (m ²)		50.6 (4.7)				66.6 (6.2)									
Coil Quantity		2				2									
2-Way Water Valve															
Valve Quantity		2				2									
2-Way Valve Size, in.		2-1/2				3									
Valve, Cv		60				70									
Valve Close Off Pressure Rating psi (kPa)		100 (689)				100 (689)									
Valve ratings psi (kPa)		400 (2,758)				400 (2,758)									
System Design Pressure Rating psi (kPa)		270 (1,861)				270 (1,861)									
2-Way Pressure Independent Water Valve															
Valve Quantity		Available upon request				4									
2-Way Valve Size, in						2"									
Valve, Cv						35.2									
Valve Close Off Pressure Rating psi (kPa)						200 (1,379)									

Table 2.6 Physical Data (continued)

Model Number	Without THD	CA604A	CA606A	CA608A	CA80SA	CA80NA	CA80SU	CA80NU
	With Integrated THD (optional)	CA604C	CA606C	CA608C	CA80SC	CA60NC	CA80SV	CA60NV
Valve Ratings psi (kPa)	Available upon request				360 (2,482)			
System Design Pressure Rating psi (kPa)	Available upon request				270 (1,861)			
Performance data available upon request								
Filter Section								
Disposable Type - Nominal Size and Quantities, MERV8 and MERV11 (optional)								
Nominal Size, in	20 x 24 x 4				20 x 24 x 4 + 16 x 24 x 4			
Quantity	33				39 + 6			
Connection Sizes								
Customer Supply and Return Chilled Water Connection Type	Braze				Braze			
Customer Supply and Return Chilled Water Connection, O.D. Copper	4"				4"			
Customer Supply and Return Chilled Water Connection Flange Size (optional)	4" (150 lb) Steel Pipe Flange				4" (150 lb) Steel Pipe Flange			
Customer Supply and Return Chilled Water Connection Grooved Size (optional)	Available upon request				4" Grooved			
Condensate Drain, FPT	3/4"				3/4"			
Condensate Pump, O.D. Copper (optional)	1/2"				1/2"			
Weight	See 20000779				See 20000252			
Damper Section (optional) - delivered separately, to be installed on site								
Damper Quantity	Available upon request				4			
Dimensional Details	Available upon request				See 20000768			

This page intentionally left blank

3 Pre-Installation Preparation and Guidelines

NOTE: Before installing unit, determine whether any building alterations are required to run piping and wiring. Follow all unit dimensional drawings and refer to the submittal engineering dimensional drawings of individual units for proper clearances.

Refer to [Vertiv™ CoolLoop Thermal Wall Model Number Nomenclature](#) on page 7 and [Submittal Drawings](#) on page 77 to determine the type of system being installed and anticipate building alterations, piping and duct work needed.

The unit dimensions, pipe connection locations, and piping schematics are described in the submittal documents included in the [Submittal Drawings](#) on page 77 .

- Verify that the floor is level, solid and sufficient to support the unit. See 20000779 for CA60 and 20000252 for CA80 unit for shipping dimensions and unit weights.
- Confirm that the room is properly insulated and has a sealed vapor barrier.
- For proper humidity control, keep outside or fresh air to an absolute minimum (less than 5% of total air circulated in the room).
- Install the units as close as possible to the largest heat load.
- Allow at least the minimum recommended clearances for maintenance and service. See the appropriate submittal drawings for dimensions.
- We recommend installing an under floor water detection system. Contact your Vertiv representative for information.

3.1 Planning Dimensions

The unit dimensions are described in the submittal documents included in the [Submittal Drawings](#) on page 77 .

Relevant documents are referenced below by number and title.

Table 3.1 Dimension Planning Drawings

Document Number (CA60/CA80)	Title
20000779 / 20000252	Cabinet and Anchor Dimensional Data, Bottom and Top Modules
20000780 / 20000756	Installation and Service Clearance
20000781 / 20000757	Floor Planning for Adjacent Units
20000782 / 20000751	Airflow Schematic

3.2 Connections and System Setup

- The unit requires a drain, which must comply with all applicable codes. See [Field Installed, Gravity Drain Line Requirements](#) on page 42 for details.
- The unit requires supply and return water connections, which must comply with all applicable codes. See [Piping Requirements](#) on page 41.
- If seismic requirements apply, refer to documents in **Table 3.2** below.

Relevant documents are referenced below by number and title.

Table 3.2 Seismic Drawings

Document Number (CA60/CA80)	Title
20000783 / 20000762	Seismic Application Assumptions and Requirements, IBC 0.75 Sds
20000784 / 20000763	Seismic Application Assumptions and Requirements, IBC 2.5 Sds

3.3 Operating Conditions

The Vertiv™ CoolLoop Thermal Wall must be operated in a conditioned space within the operating envelope that ASHRAE recommends for data centers. Operating the Vertiv™ CoolLoop Thermal Wall outside of this envelope can decrease equipment reliability. Refer to ASHRAE's publication, "Thermal Guidelines for Data Processing Environments."

The unit is designed for indoor installation, protected from weather agents. Refer to the Table 3.3 for the recommended operating conditions.

Table 3.3 Operating Conditions

Return Air Conditions	Maximum recommended temperature without performance de-rating (1)	113°F (45°C)
	Maximum recommended dew point	59°F (15°C)
	Minimum recommended return air temperature set-point	85°F (29.4°C)
Chilled Water System	Maximum inlet water temperature	122°F (50°C)
	Minimum inlet water temperature (2)	53°F (11.7°C)
	Maximum water pressure	270 psi (18.6 bar)
	Water-Glycol mixture	Up to 50% volume.
Maximum air temperature at which the unit can operate		122°F (50°C)
Maximum altitude without de-rating (3)		6562 ft (2000 m)

(1) For operation at return air temperature between 113°F (45°C) and 122°F (50°C), contact your Vertiv® representative.

(2) The inlet water temperature must be selected to avoid condensation.

(3) For applications at greater altitude, contact your Vertiv® representative.

3.3.1 Humidification Control

The humidifier option is not available on the Vertiv™ CoolLoop Thermal Wall. An optional remote humidifier contact is available for a stand-alone humidifier.

3.3.2 Storage conditions

The unit must be storage upright in an indoor environment, protected against weather agents, dampness, freezing temperatures and contact damage; clean (no dust), well-ventilated, avoiding any possible condensation formation.

NOTICE

Vertiv™ is not responsible for improper use of the unit, such as applications outside the specified limits in this chapter. Working outside the specified limits may cause breaks and damage, compromising unit operation

3.4 Shipping Dimensions and Unit Weights

See submittal 20000779 for CA60 and 20000252 for CA80 unit for weights and dimensions (dry, operating and shipping).

3.5 Site Preparation

Prepare the site for installation prior to the arrival and unloading of the unit.

- If installing the unit on a concrete slab or housekeeping pad, sweep the concrete clean and mark the final position of the unit(s) on the slab.
- Verify that all required clearances as specified by Vertiv are met.
- Mark the direction of the final unit placement to avoid accidental reversal of the unit.
- Protect stub outs for electric conduit and any projects against damage and clearly mark their locations.
- Locate and mark the high point on the slab. This step is critical for the placement of multiple, joined units.
- If installing on a structural steel support structure, verify suitability of the supports beneath the unit(s).

3.5.1 Preparing a Concrete Slab

Prepare the concrete slab by locating and marking the high point to assist with shimming the unit. The unit must be installed level.

1. Sweep the slab broom clean.
2. Lay out the final location of the unit on the slab using either chalk line or tape.
3. Using a laser level or an optical level, locate the high point on the slab and mark it.

See **Figure 3.1** below.

Figure 3.1 Unit and High Point Marking on Concrete Slab

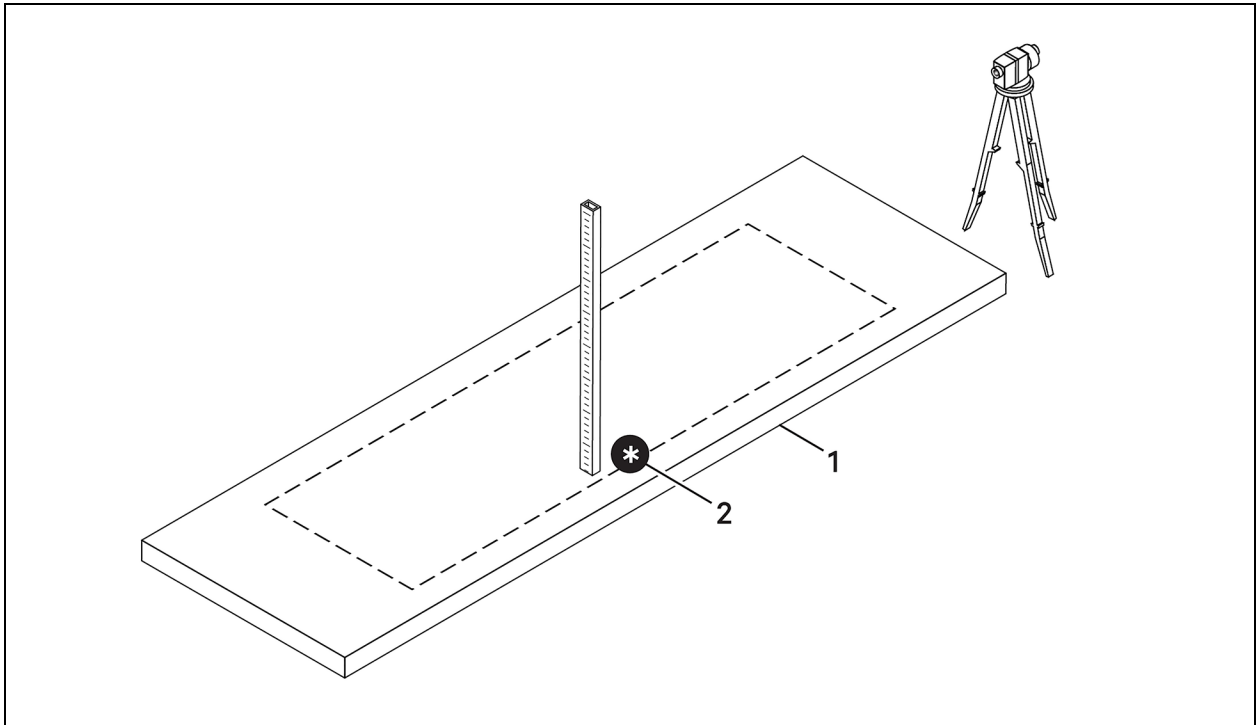

Item	Description
1	Concrete slab
2	High point

4 Equipment Inspection and Handling and Installation



WARNING! Risk of top heavy unit falling over. Improper handling can cause equipment damage, injury or death. Read all of the following instructions and verify that all lifting and moving equipment is rated for the weight of the unit before attempting to move, lift, remove packaging from or prepare the unit for installation. Unit weights are specified in 20000779 for CA60 and 20000252 for CA80 unit.



WARNING! Risk of improper moving. Can cause equipment damage, injury or death. Use only lifting equipment that is rated for the unit weight by an OSHA-certified rating organization. The center of gravity varies depending on the module. Shipping weights and unit weights are listed in 20000779 for CA60 and 20000252 for CA80 unit.



CAUTION: Risk of contact with sharp edges, splinters, and exposed fasteners. Can cause injury. Only properly trained and qualified personnel wearing appropriate, OSHA-approved PPE should attempt to move, lift, remove packaging from or prepare the unit for installation.

NOTICE

Risk of passageway interference. Can cause unit and/or structure damage. The unit may be too large to fit through a passageway while on or off the skid. Measure the unit and passageway dimensions, and refer to the installation plans prior to moving the unit to verify clearances.

NOTICE

Risk of damage from forklift. Can cause unit damage. Keep tines of the forklift level and at a height suitable to fit below the skid and/or unit to prevent exterior and/or underside damage.

NOTICE

Risk of improper storage. Keep the unit upright, indoors and protected from dampness, freezing temperatures, contact damage, and avoid any possible condensation formation.

Upon arrival of the unit and before unpacking:

- Verify that the labeled equipment matches the bill of lading.
- Carefully inspect all items for visible or concealed damage.
- Report damage immediately to the carrier and file a damage claim sent to Vertiv™ or to your sales representative.

Appropriate sized forklift is to be used while moving packaged modules. Equipment used for installation is to be determined by professional riggers.

4.1 Packaging Material



All material used to package this unit is recyclable. Please save for future use or dispose of the material appropriately.

4.2 Handling the Modules While Packaged

The top and bottom modules are shipped as separate units and must be unpacked as separate units.

NOTE: A professional rigger is required to lift and assemble the top and bottom modules as well as to move the assembled unit into place.

Transport modules with a forklift rated for the weight of the unit. Refer to 20000779 for CA60 and 20000252 for CA80 unit for shipping dimensions and unit weights.

When using a forklift:

- Ensure that the fork length is suitable for the unit length and, if adjustable, spread to the widest allowable distance that will fit under the skid.
- When moving the packaged unit, lift the unit from the end and do not lift the unit any higher than 4 in. (102 mm). Ensure that the opposite end of the skid still touches the floor. All personnel except those moving the unit must be kept 12 ft (3.7 m) or more from the unit while it is being moved.
- If the unit must be lifted higher than 4 in. (102 mm), all personnel not directly involved in moving the unit must be 20 ft (5 m) or farther from the unit.

4.3 Unpacking the Modules

Unpacking and preparation of each module includes these steps:

1. Remove the exterior stretch wrap packaging from around the unit and any protective corner and side packaging planks.
2. Remove the filter rack assembly on each module. Filters are removed from the center position of the slotted filter rack. Lift up and out to remove. Refer to **Table 4.1** below and [Submittal Drawings](#) on page 77 .

Relevant documents are referenced below by number and title.

Table 4.1 Filter and Filter Rack Location Drawings

Document Number	Title
20000785	Filter and Filter Rack Removal for CA60 unit
20000755	Filter and Filter Rack Removal for CA80 unit

4.3.1 Filter and Rack Removal

NOTICE

Risk of damage to filter rack. Remove filter racks prior to rigging module and replace after module is set in place.

Removal Process

1. Remove filter from center position of filter rack.
2. Lift filters up and out to remove from rack.
3. Loosen two screws located in slots at top and bottom of each filter rack.

NOTE: Do not remove screws.

4. Lift filter racks up and out to remove.

5. Reverse this position to re-attach filter racks and inserting filter.

4.4 Preparing for Assembly

4.4.1 Top Module Prep on Skid

1. Remove the top module piping access panel to access the internal piping for supply and return connections. The panel is located on the gallery side of the unit. See **Figure 4.1** below and **Figure 4.2** on the next page.

NOTE: Access panel screws have a maximum torque value of 40 in-lbs.

Figure 4.1 Gallery Side, Top Module, Piping Access Panel

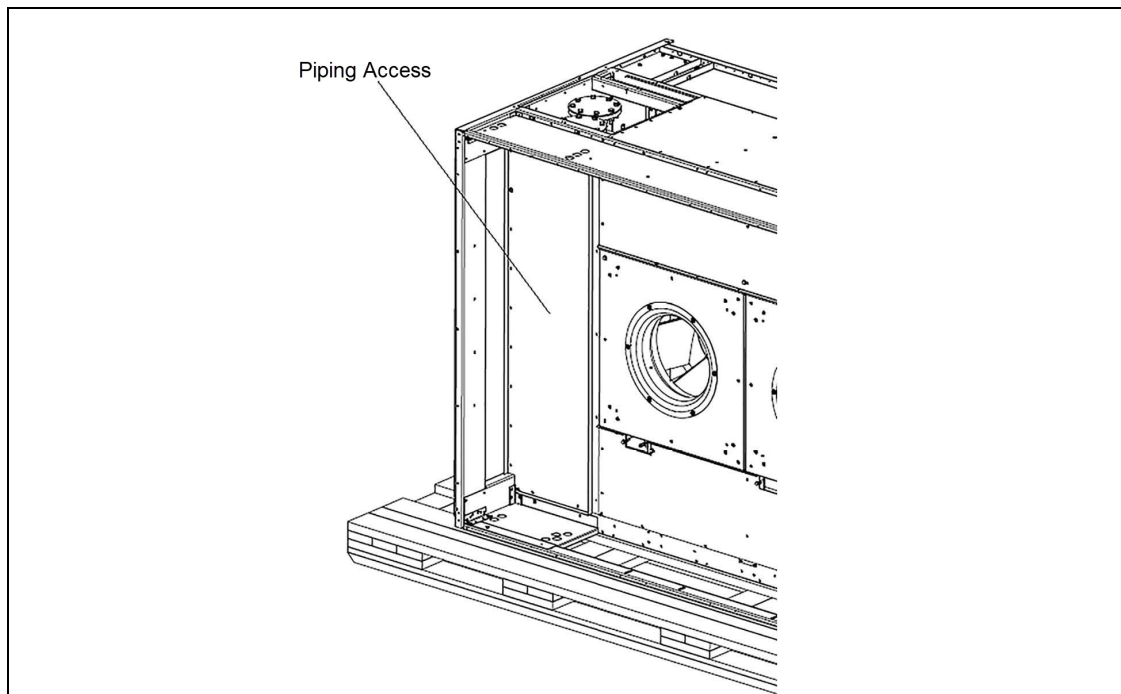

NOTE: The figures are referring to the CA60 unit, for the CA80 the assembly procedure is similar. For the detailed pictures refer to the document 20000758.

Figure 4.2 Gallery Side, Top Module Piping Access to Internal Supply and Return Piping Connections

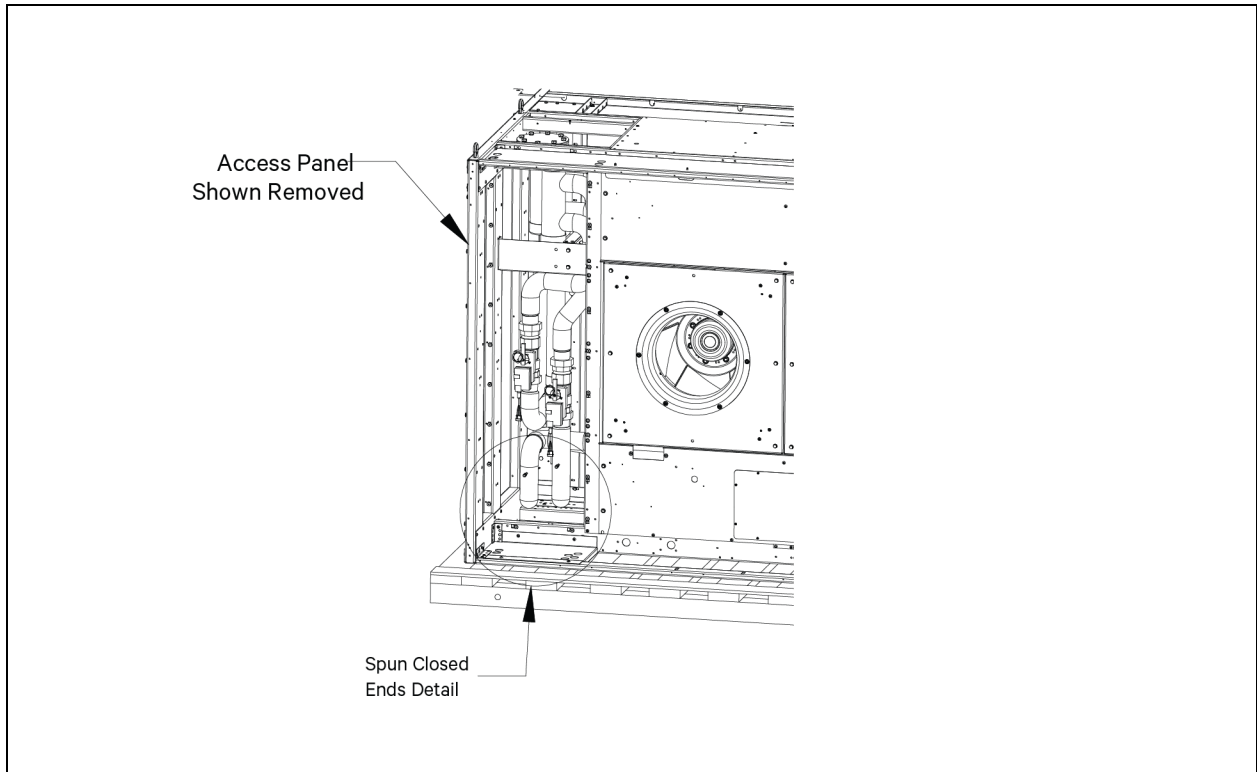

NOTE: The figures are referring to the CA60 unit, for the CA80 the assembly procedure is similar. For the detailed pictures refer to the document 20000758.

2. Before removing any fittings or cutting copper tubing, vent the holding charge by using the Schrader valves provided on the module. Schrader valves on the connections are intended solely for venting the unit.
3. Prepare the internal piping connections by removing the spun closed ends and cutting to the specified dimensions. See **Figure 4.2** above and **Figure 5.2** on page 37, for the CA80 unit refer to the document 20000758.

4.4.2 Customer Piping Installation Validation

To ensure a proper installation and integration, the critical Connection measurements are provided in this section. These measurements include the location of the chilled water connection. Providing this data allows for accurate planning and preparation before installation.

It is the responsibility of the client to review and validate these measurements on-site to confirm alignment with their system layout and physical constraints. Verifying the connection locations in advance helps prevent installation errors, reduces downtime, and ensures a smooth commissioning process.

NOTE: The origin of the measurements shown is from the internal wall and floor inside the connection section of top module. Horizontal tolerance is 1" (25mm). Pipes can shift during transport.

Figure 4.3 Top Level Assembly Piping

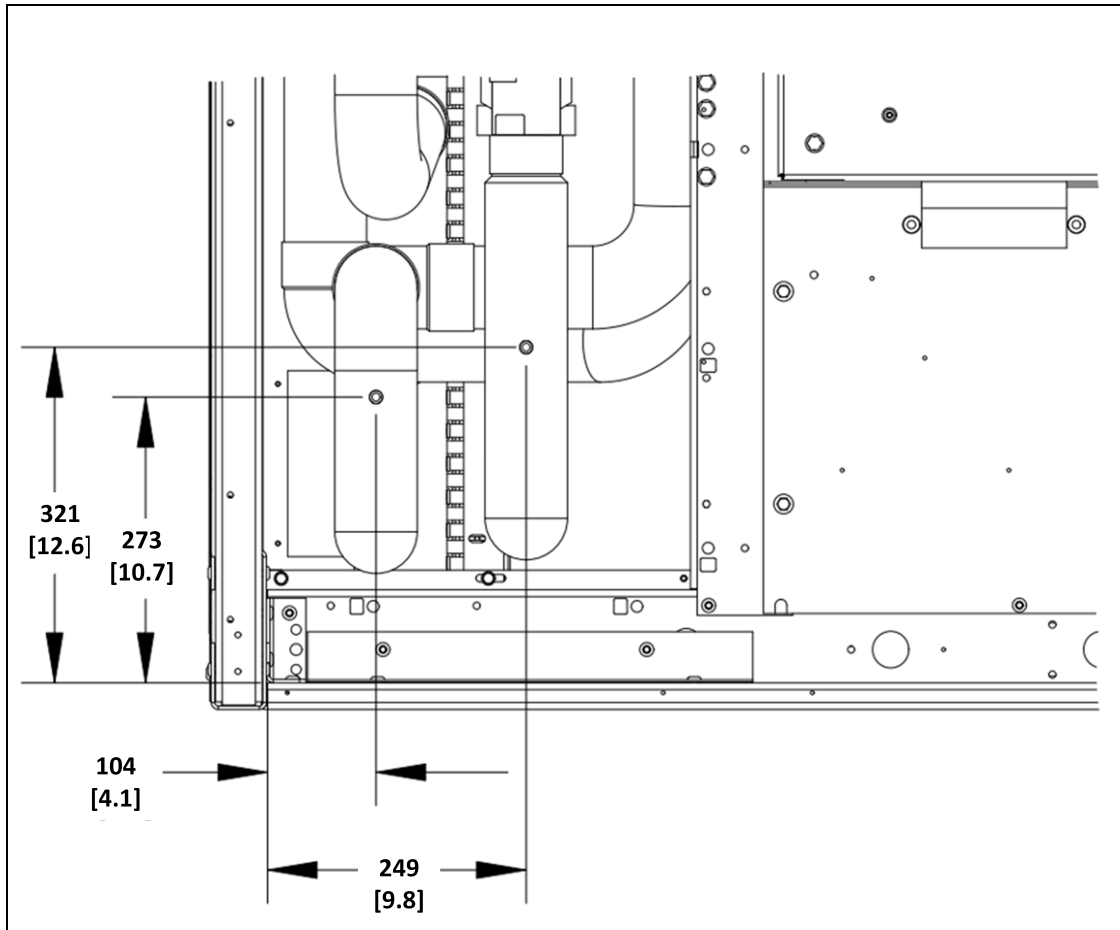

NOTE: The figures are referring to the CA60 unit, for the CA80 the assembly procedure is similar. For the detailed pictures refer to the document 20000758.

Figure 4.4 Bottom Module Supply and Return Pipe Detail

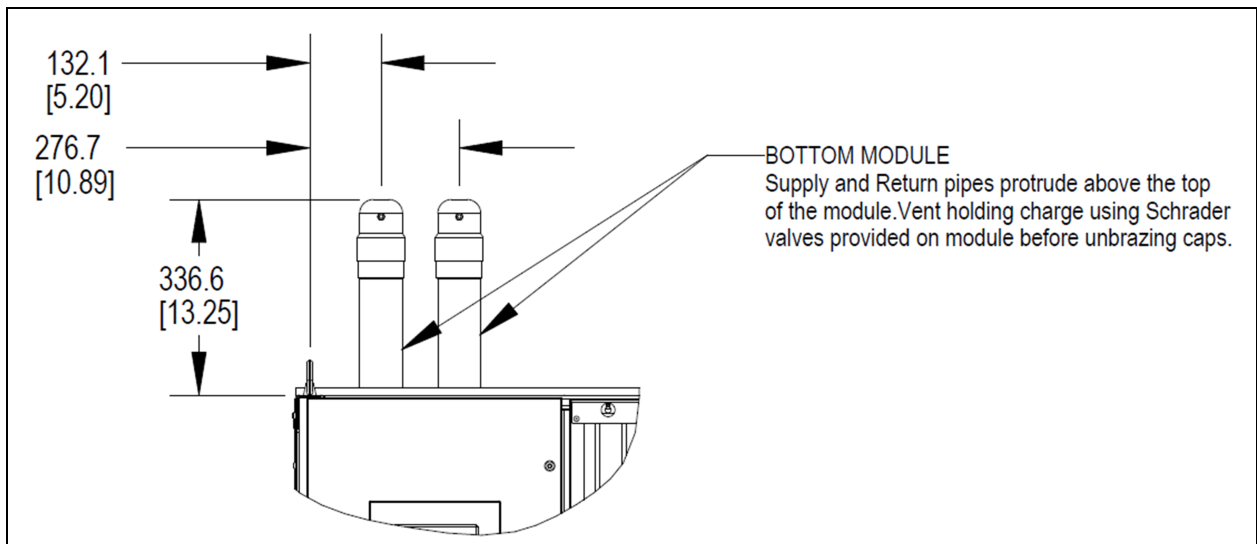

NOTE: The figures are referring to the CA60 unit, for the CA80 the assembly procedure is similar. For the detailed pictures refer to the document 20000758.

NOTE: Remove exterior packaging material from module. Units ship in two sections, top module and bottom module. Each module is fastened to the shipping skid with lag screws through the provided mounting holes. Remove filter rack assemblies from each module. See 20000785 for CA60 and 20000755 for CA80 unit for details on filter rack removal. Dimensions are in mm [in].

Figure 4.5 Dimensions Required for Connection to Bottom Module

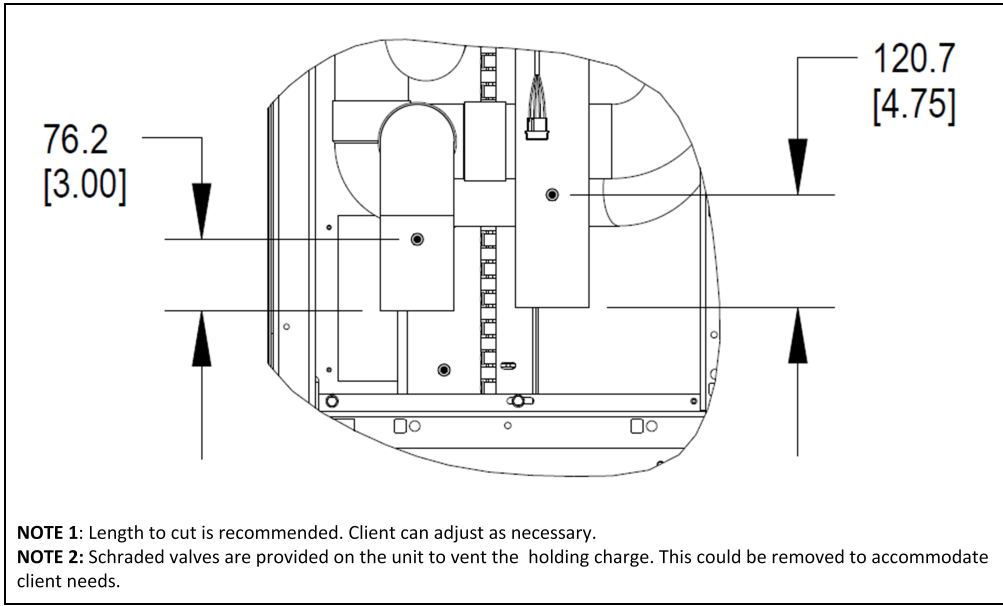

NOTE: The figures are referring to the CA60 unit, for the CA80 the assembly procedure is similar. For the detailed pictures refer to the document 20000758.

1. Remove any excess piping material using a tube cutter or other non-burring device.
2. Clean up shavings and other materials before making the supply and return piping connections.

Figure 4.6 Spun Closed Ends Detail

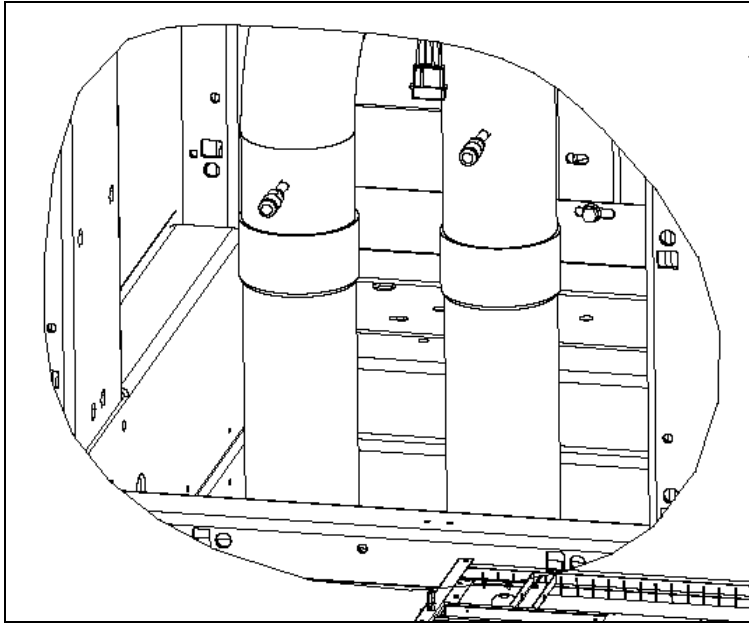

NOTE: The figures are referring to the CA60 unit, for the CA80 the assembly procedure is similar. For the detailed pictures refer to the document 20000758.

4.4.3 Top Module—Venting the Inert Gas Holding Charge

The module is shipped with an inert gas holding charge. Vent the holding charge using the Schrader valve that is provided on the unit before removing any fittings. Refer to 20000786 for CA60 and 20000758 for CA80 unit, Top and Bottom Module Assembly in [Submittal Drawings](#) on page 77 for details.



CAUTION: Use good practice when piping the unit and the system.

4.4.4 Bottom Module Prep on Skid



CAUTION: Use good practice when piping the unit and the system.

The supply and return pipes protrude above the top of the module. Vent the holding charge using Schrader valves provided on the bottom module before removing the fittings. see **Figure 4.4** on page 23

4.4.5 Bottom Module—Venting the Inert Gas Holding Charge

The module is shipped with an inert gas holding charge. Vent the holding charge using the Schrader valve that is provided on the unit before removing any fittings.

Figure 4.7 Gallery Side Top Module

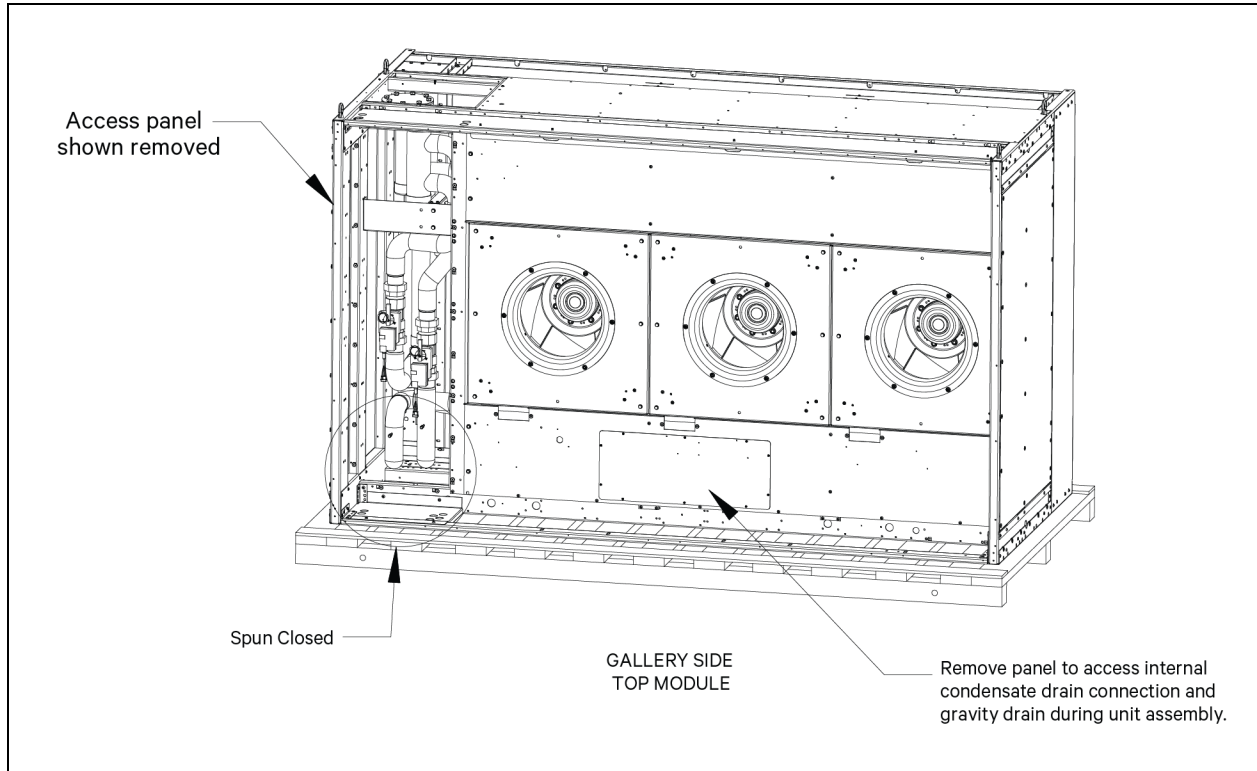

NOTE: The figures are referring to the CA60 unit, for the CA80 the assembly procedure is similar. For the detailed pictures refer to the document 20000758.



CAUTION: Use good practice when piping the unit and the system.

Before any brazing occurs, make sure that the internal part of the piping joints has been cleaned.

Refer to **Figure 4.8** on the next page.

Figure 4.8 Clean Internal Joint Parts, Bottom Module

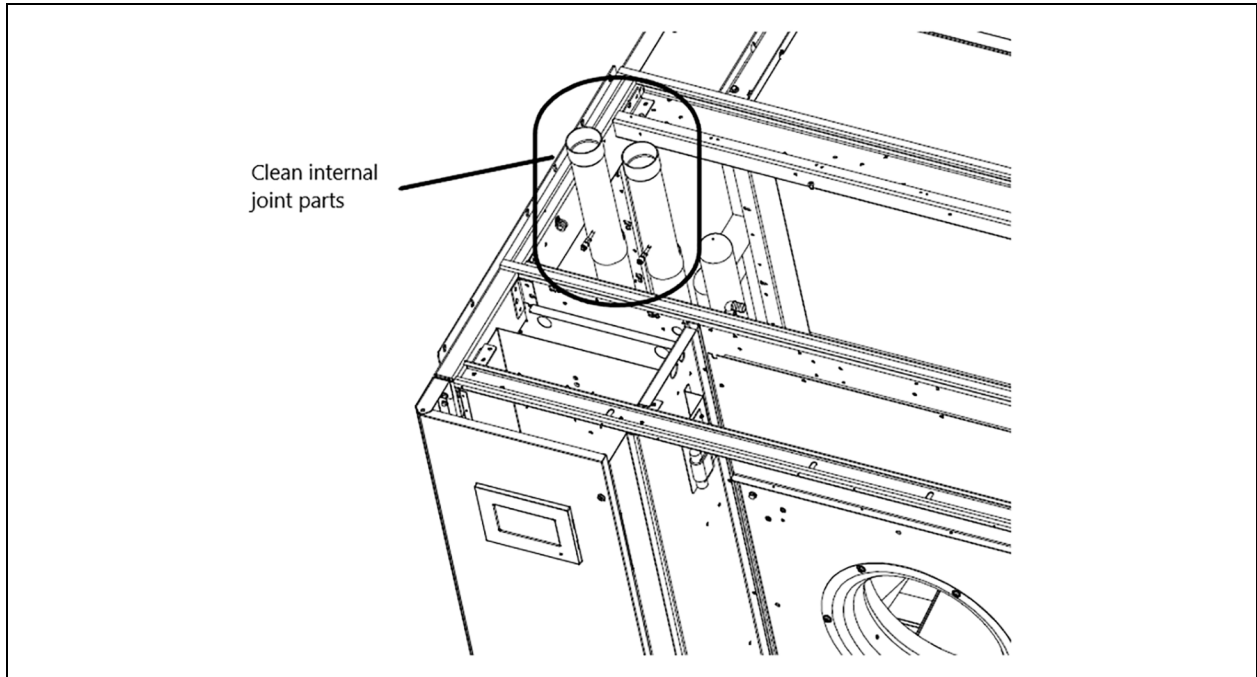

NOTE: The figures are referring to the CA60 unit, for the CA80 the assembly procedure is similar. For the detailed pictures refer to the document 20000758.

If the Side Gravity Condensate Connection Conversion Kit has been purchased, reference Vertiv document number 20000801 for CA60 and 20000767 for CA80 unit for installation steps. This kit must be installed before the lower module is placed.

Figure 4.9 Installation Clearance

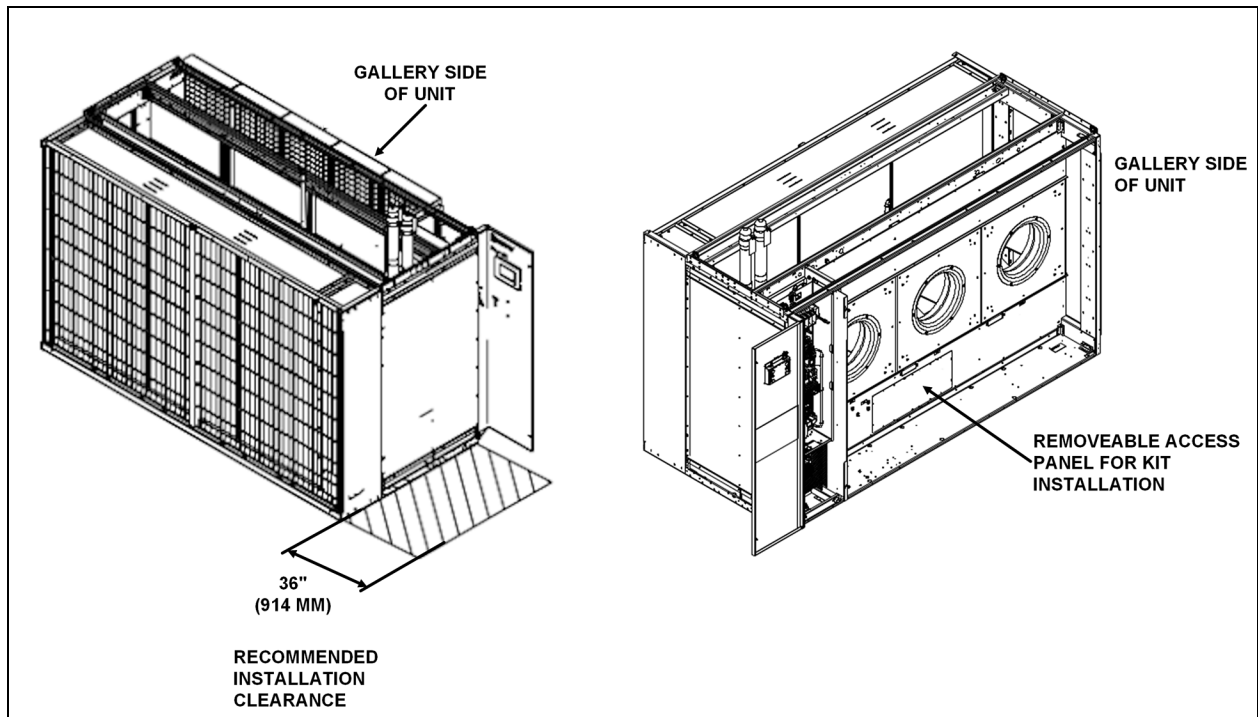

NOTE: The figures are referring to the CA60 unit, for the CA80 the assembly procedure is similar. For the detailed pictures refer to the document 20000758.

4.4.6 Removing Lag Screw Shipping Fasteners

Both modules are attached to its shipping skid with lag screws.

Use a socket drive to remove the lag screws. There is a total of 7 lag screws per module. The Bottom Module has a quantity of seven (7) 3/8-7 x 1.5 inch lag screws, each with a flat washer. The Top Module has a quantity of three (3) 3/8-7 x 1.5 inch lag screws, and a quantity of four (4) 3/8-7 x 3 inch lag screw; each with a flat washer. See **Figure 4.10** on the next page. If the unit is equipped with Vertiv™ Liebert® Liqui-Tect™ option, the access cover from the bottom module must be removed from the data hall side to locate lag screws. Vertiv™ Liebert® Liqui-Tect™ access cover must be replaced.

Figure 4.10 Lag Screw Removal

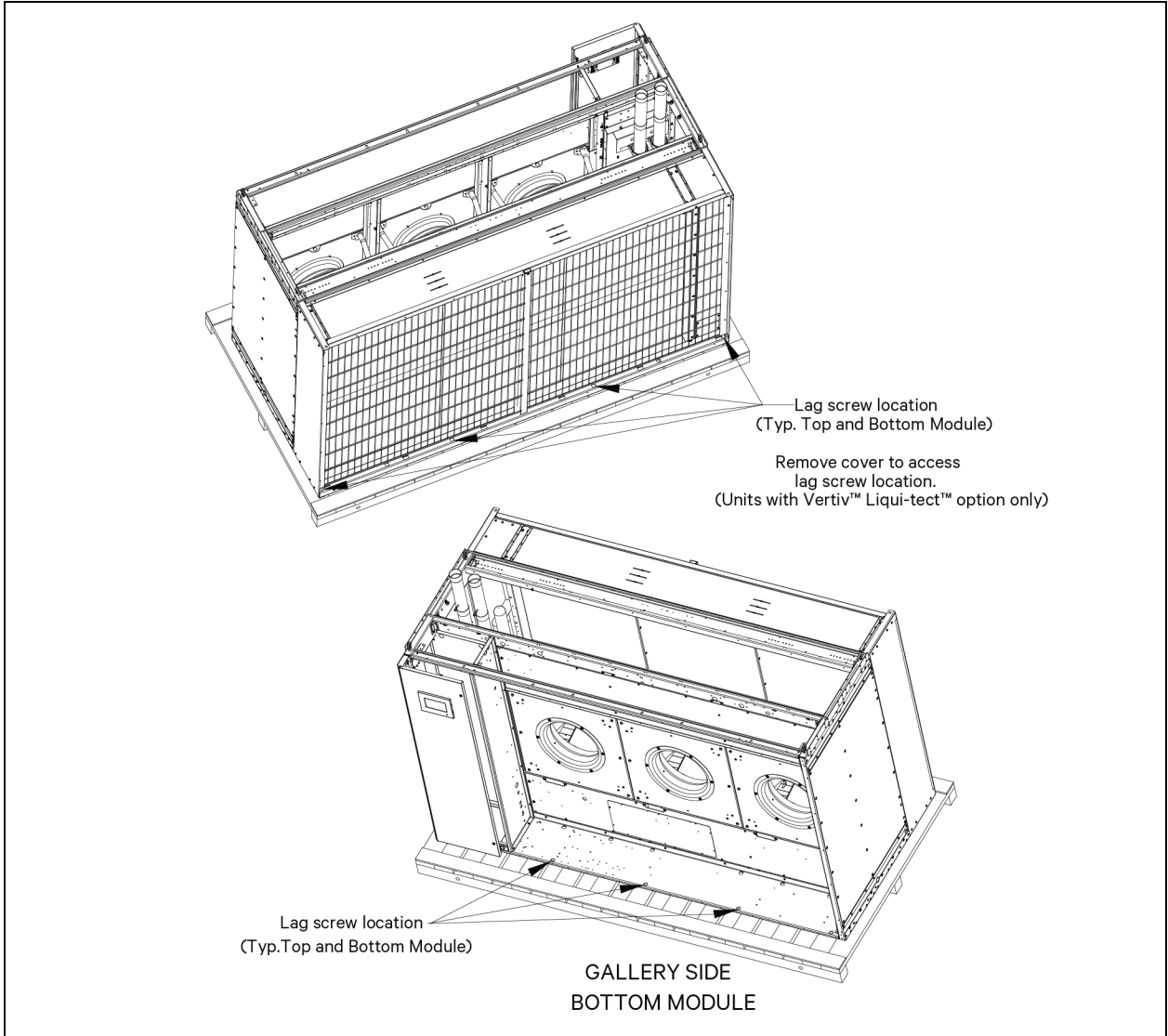

NOTE: The figures are referring to the CA60 unit, for the CA80 the assembly procedure is similar. For the detailed pictures refer to the document 20000758.

Relevant documents are referenced in **Table 4.2** below by number and title.

Table 4.2 Lag Screw Drawings

Document Number	Title
20000786	Top and Bottom Module Assembly for CA60
20000758	Top and Bottom Module Assembly for CA80

4.5 Assembly of Top and Bottom Modules

NOTE: A professional rigger is required to lift and assemble the top and bottom modules as well as to move the assembled unit into place. A professional rigger is required to move the assembled unit into place.



CAUTION: Risk of contact with sharp edges, splinters, and exposed fasteners. Can cause injury. Only properly trained and qualified personnel wearing appropriate, OSHA-approved PPE should attempt to move, lift, remove packaging from or prepare the unit for installation. Protect against sharp edges at the lift points of each unit.

Figure 4.11 Lifting Points

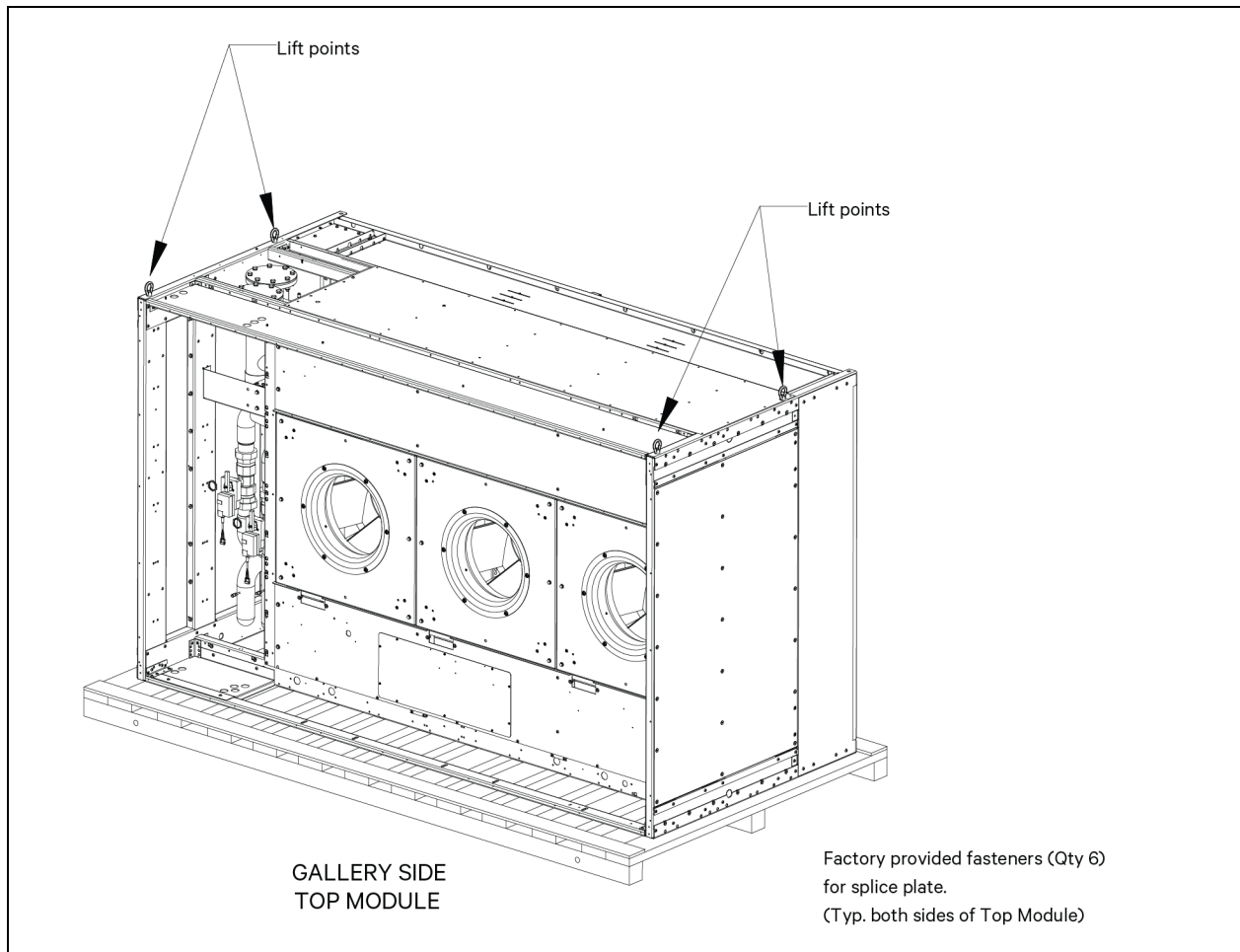

NOTE: The figures are referring to the CA60 unit, for the CA80 the assembly procedure is similar. For the detailed pictures refer to the document 20000758.

NOTE: Access panel screws have a maximum torque value of 40 in-lbs.

1. Remove the factory provided hardware from both sides of the top module for splice plate attachment.
2. Lifting force must be completely vertical at each lift point location.
3. Each module must be lifted separately.
4. After coupling the bottom and top modules, it is not allowed to lift the assembly using any means.

4.6 Final Installation

1. Field must use a professional rigger to lift and assemble the top and bottom module. Each module must be lifted separately. After coupling the bottom and the top modules, it is not allowed to lift the assembly using any means.
2. Align and mount top module onto bottom module. If top module is leaning toward the front (data hall) creating a small gap in the rear (gallery) side, where the top and bottom modules meet, use clamps on the rear (gallery) side of the unit to close the gap between modules.
3. Fasten modules together with factory-provided splice plates and fasteners (typical both ends of unit).
4. Braze internal piping connections.
5. Assemble internal condensate connection between top and bottom module (See 20000788 for CA60 and 20000759 for CA80 unit for details).
6. Leak check the assembled unit.
7. Field must use a professional rigger to move the assembled unit into place. (See 20000779 for CA60 and 20000252 for CA80 unit for bottom module mounting. For seismic rated units, reinstall rear bracing, see **Figure 4.13** on page 34.)
8. Complete electrical connection for the supply air sensors system (see document 20000769 for CA80 unit).
9. Complete electrical connection for the low voltage chilled water valves and then reattach panel covers on the top module piping section and top and bottom module lifting points. (for the CA80 unit, with the optional 2-way EPIV it's necessary to connect both power and control cables) Valve reference name written on the connectors labels to guarantee the correct electrical connection.
10. Complete electrical connections for top module fans and then reinstall filter racks on top and bottom module.
11. Anchor modules to pad using bolt grade to be specified by local requirements.

See [Submittal Drawings](#) on page 77 .

Figure 4.12 Top and Bottom Module Assembly

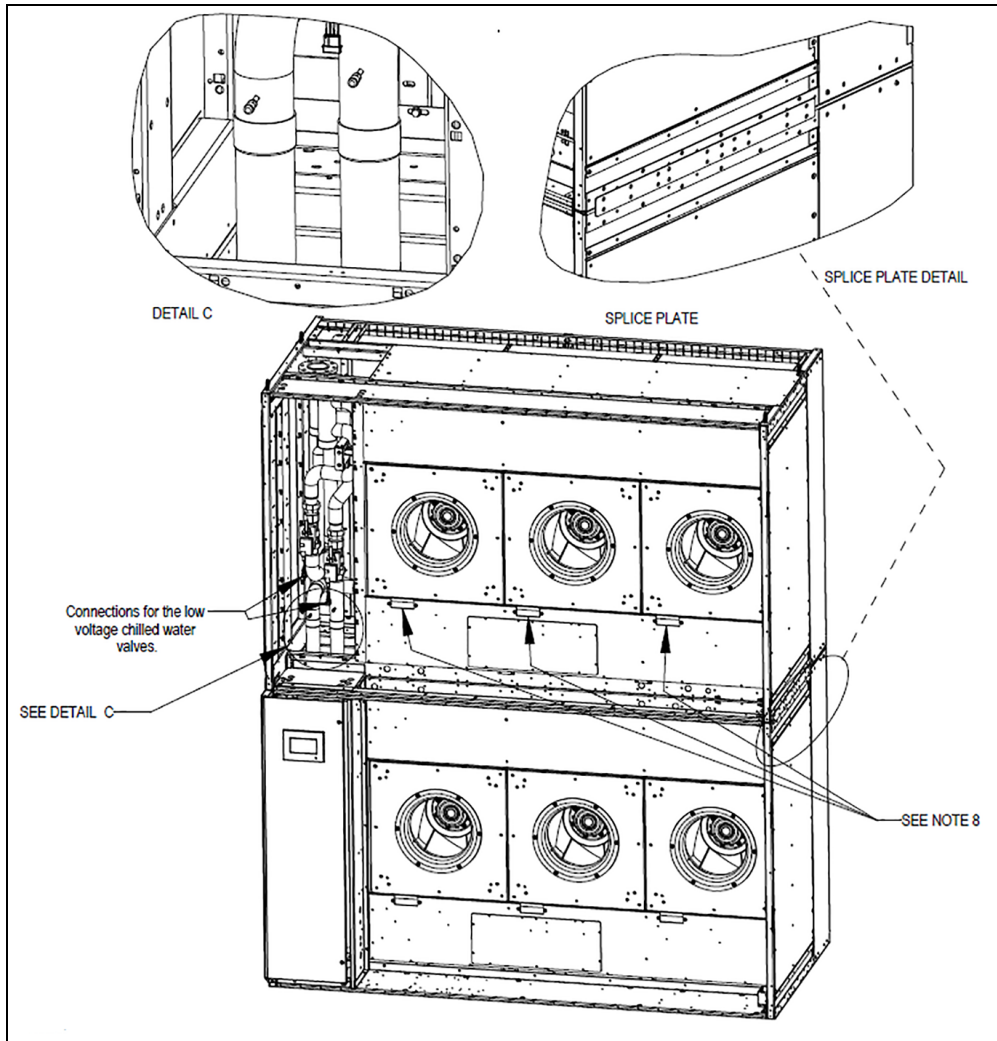

NOTE: The figures are referring to the CA60 unit, for the CA80 the assembly procedure is similar. For the detailed pictures refer to the document 20000758.

Figure 4.13 External Bracing for Seismic Units

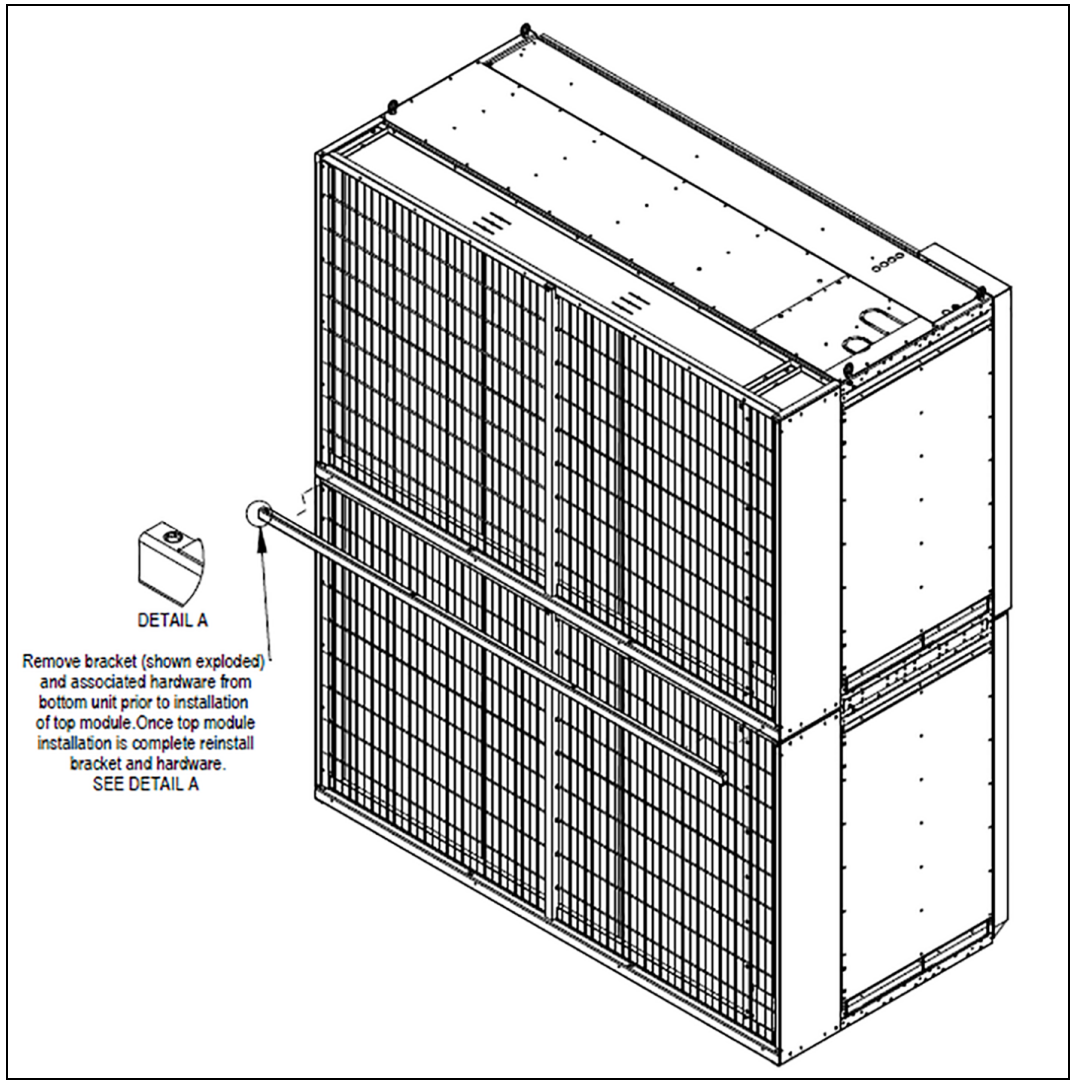

NOTE: The figures are referring to the CA60 unit, for the CA80 the assembly procedure is similar. For the detailed pictures refer to the document 20000758.

4.7 Damper Installation (Optional)

The optional damper installation kit will be delivered separately and must be installed on the site before the assembly of the bottom and top modules. Refer to the document 20000768 for the detailed information.

5 Electrical Connections

Three-phase electrical service is required for all models. Electrical service must conform to national and local electrical codes. Refer to equipment nameplate regarding wire size and circuit protection requirements. Refer to electrical schematic when making connections. Refer the appropriate submittal drawing, listed in **5** above, for electrical service entrances into unit.

A manual electrical disconnect switch should be installed in accordance with local codes and distribution system. Consult local codes for external disconnect requirements.



WARNING! Arc flash and electric shock hazard. Open all local and remote electric power supply disconnect switches, verify with a voltmeter that power is Off and wear appropriate, OSHA-approved personal protective equipment (PPE) per NFPA 70E before working within the electric control enclosure. Failure to comply can cause serious injury or death. Customer must provide earth ground to unit, per NEC, CEC and local codes, as applicable. Before proceeding with installation, read all instructions, verify that all the parts are included and check the nameplate to be sure the voltage matches available utility power. The Vertiv™ iCOM™ controller does not isolate power from the unit, even in the “Unit Off” mode. Some internal components require and receive power even during the “Unit Off” mode of the controller. The only way to ensure that there is NO voltage inside the unit is to install and open a remote disconnect switch. Refer to unit electrical schematic. Follow all local codes.



WARNING! Risk of improper wiring, piping, moving, lifting and handling. Can cause equipment damage, serious injury or death. Installation and service of this equipment should be done only by qualified personnel who have been specially trained in the installation of air conditioning equipment and who are wearing appropriate, OSHA-approved PPE.



WARNING! Risk of improper wire sizing/rating and loose electrical connections. Can cause overheated wire and electrical connection terminals resulting in smoke, fire, equipment and building damage, injury or death. Use correctly sized copper wire only and verify that all electrical connections are tight before turning power On. Check all electrical connections periodically and tighten as necessary.

NOTICE

Risk of improper power supply connection. Can cause equipment damage and loss of warranty coverage.

Prior to connecting any equipment to a main or alternate power source (for example: backup generator systems) for start up, commissioning, testing, or normal operation, ensure that these sources are correctly adjusted to the nameplate voltage and frequency of all equipment to be connected. In general, power source voltages should be stabilized and regulated to within $\pm 10\%$ of the load nameplate nominal voltage. Also, ensure that no three-phase sources are single phased at any time.

See transformer label for primary tap connections. Installer will need to change transformer primary taps if applied unit voltage is other than pre-wired tap voltage.

The electrical and unit to unit connections are described in the submittal documents included in the [Submittal Drawings](#) on page 77 .

Relevant documents are referenced below by number and title.

Table 5.1 Electrical Field Connection Drawings

Document Number		Title
CA60	CA80	
20000787	20000255	Electrical Fiel Connections, Bottom and Top Modules
20000760		Electrical Data (FLA, WSA, OPD)
20000800	20000253	Primary Connection Locations with Brazed Customer Connections
20000776	20000254	Primary Connection Locations with Flanged Customer Connections
-	20000566	Primary Connection Locations with Grooved Customer Connections
Automatic Transfer Switch (ATS)		
DPN005196		Auto Transfer Switch (ATS)
THD Transformer		
20000802	-	CA60 THD Mitigation High Airflow, High Efficiency Fan
-	20000764	CA80 THD Mitigation High Airflow, High Efficiency Fan
-	20000765	CA80 THD Mitigation Ultra Performance Fan
Unit to Unit Networking		
20000347		Vertiv™ Liebert® iCOMTM Unit to Unit Network Connections
Temperature and Humidity Sensor		
-	20000769	Supply Air Sensors Connection
20000583		2T Rack Temperature sensor Connection
DPN000960		Remote Temperature and Humidity Sensor
Damper Kit		
-	20000768	Damper Installation Kit Instructions

5.1 Low Voltage Liqui-Tech Sensor Location

The LT460 provides zone leak coverage within the bottom module by utilizing a leak detection cable. A cable termination sensor box is powered by 24 VAC from the Vertiv™ CoolLoop Thermal Wall unit with two Form-C dry contact common alarm relay outputs rated at 24 VAC, 3 amp to remotely signal leak detected, loss of power and cable fault. See **Figure 5.1** on the facing page and **Figure 5.2** on the facing page.

Figure 5.1 LT460 Sensor Location

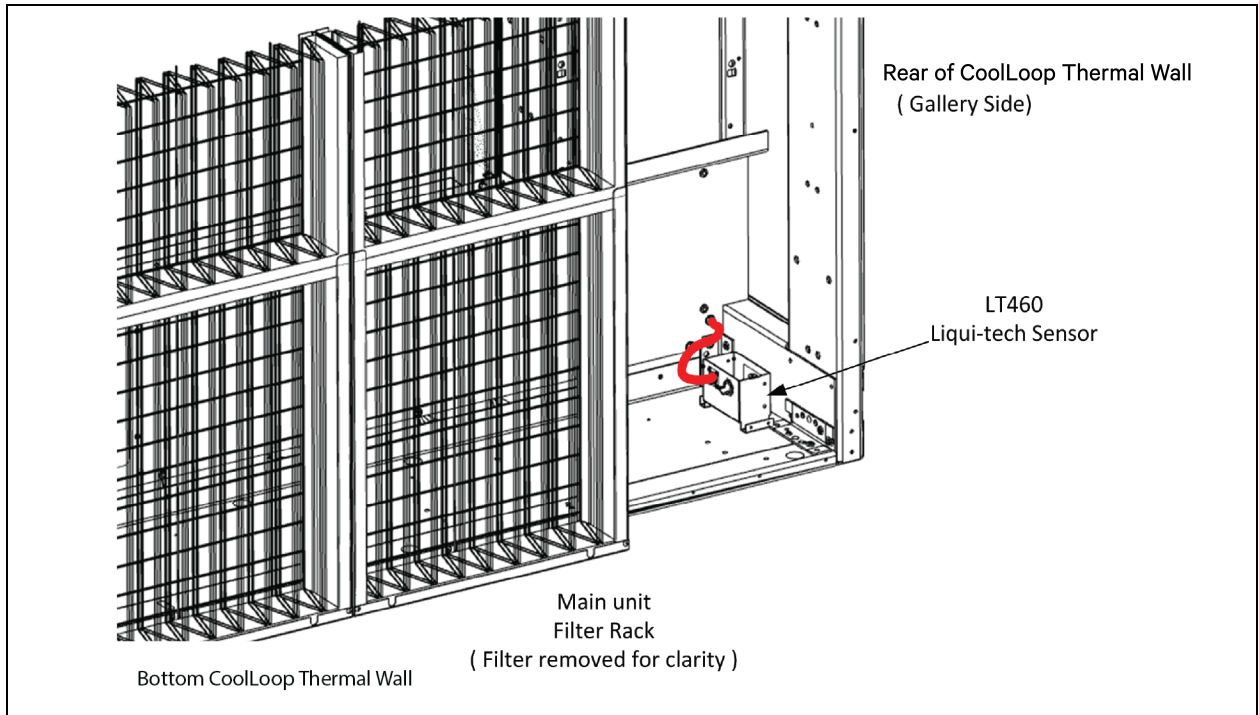

NOTE: The figures are referring to the CA60 unit, for the CA80 unit the sensor position is equivalent.

Figure 5.2 Approximate Cable Routing LT460

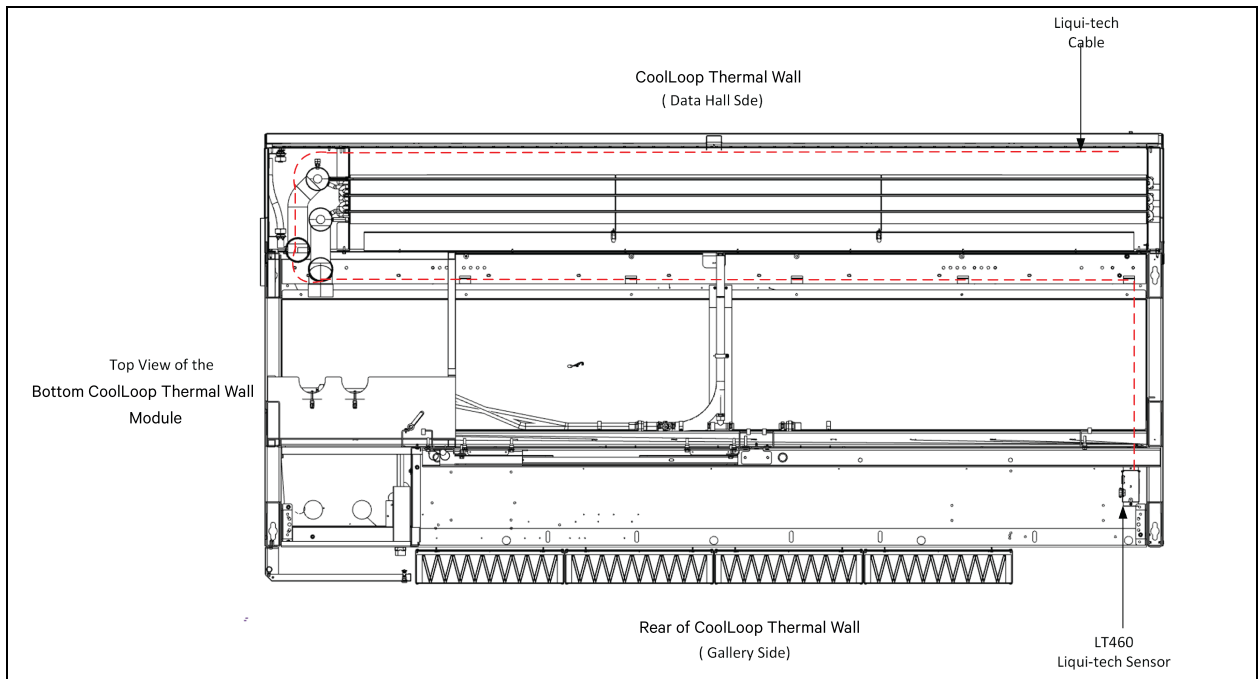
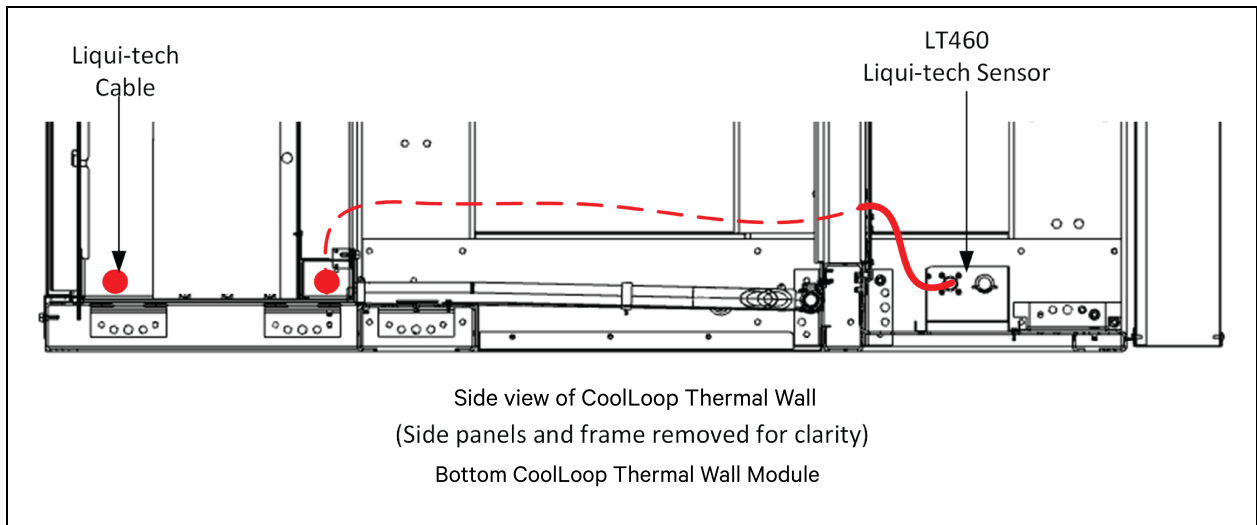

Figure 5.3 Approximate Cable Routing LT460



NOTE: The figures are referring to the CA60 unit, for the CA80 unit the sensor position is equivalent.

5.2 Air Temperature Sensor Location (Data Hall Side Only)

For CA60 unit there is one data hall side air temperature sensor to measure the supply air temperature. See **Figure 5.4** below for locations of the sensor.

Figure 5.4 CoolLoop Thermal Wall Sensor Location (CA60)

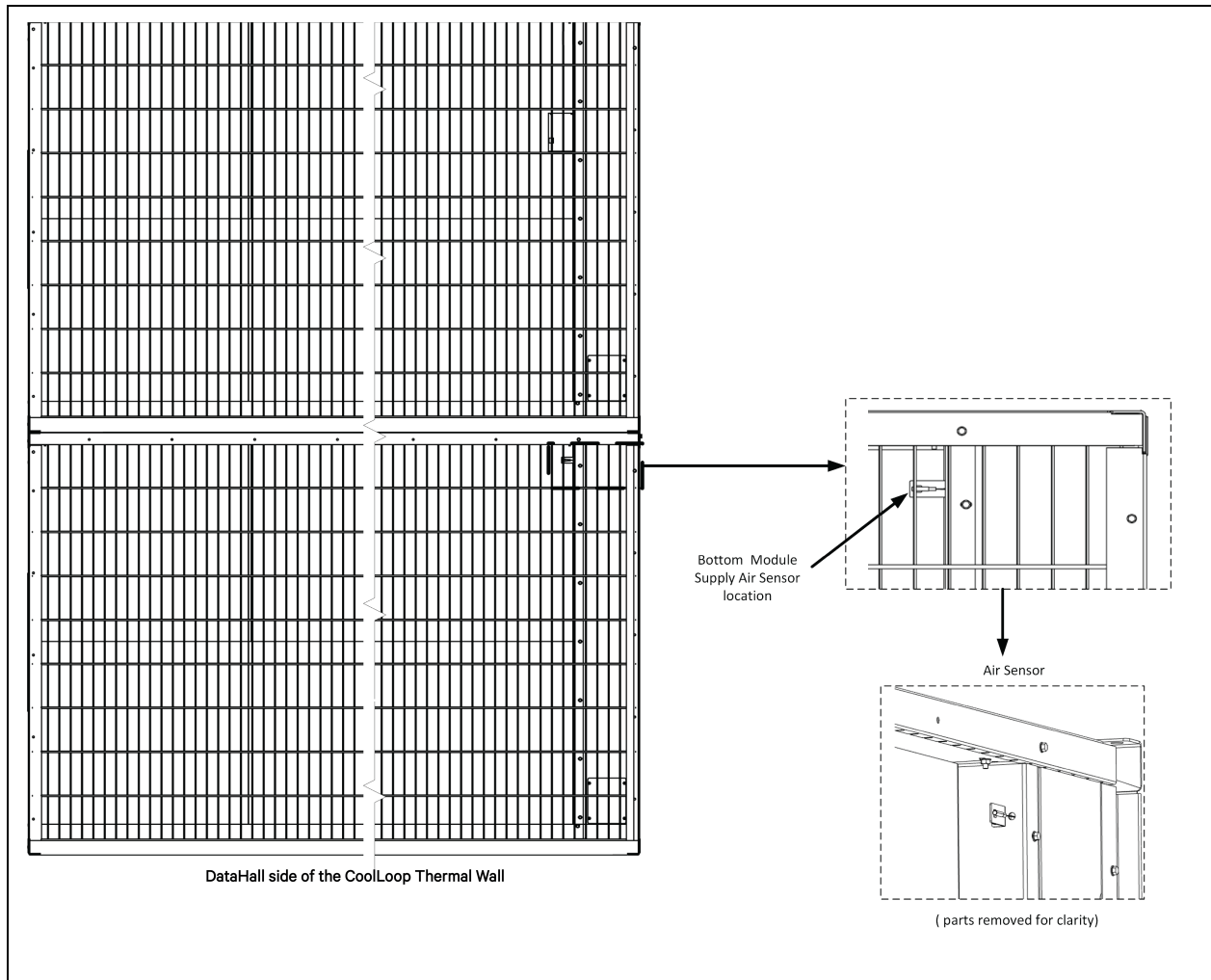

Available upon request the possibility to install extra supply temperature sensors on the unit data hall side.

NOTE: The unit installed sensor captures data from a single point on the coil, which may significantly differ from the average air temperature due to varying operational conditions such as inlet temperature, coil loading and fan speed. In order to improve the supply temperature reading accuracy, it is suggested to:

- Control based on return air temperature, which offers a better representation of the system's average air temperature.
- Install remote sensors downstream of the unit.
- Use multiple sensors distributed across the rack or row level to aggregate a more representative airflow temperature.

For CA80 unit there are two data hall side air temperature sensors, for a total of four sensible points, to measure the supply air temperature. See **Figure 5.5** below for location of the sensors.

Figure 5.5 CoolLoop Thermal Wall Sensors Location (CA80)

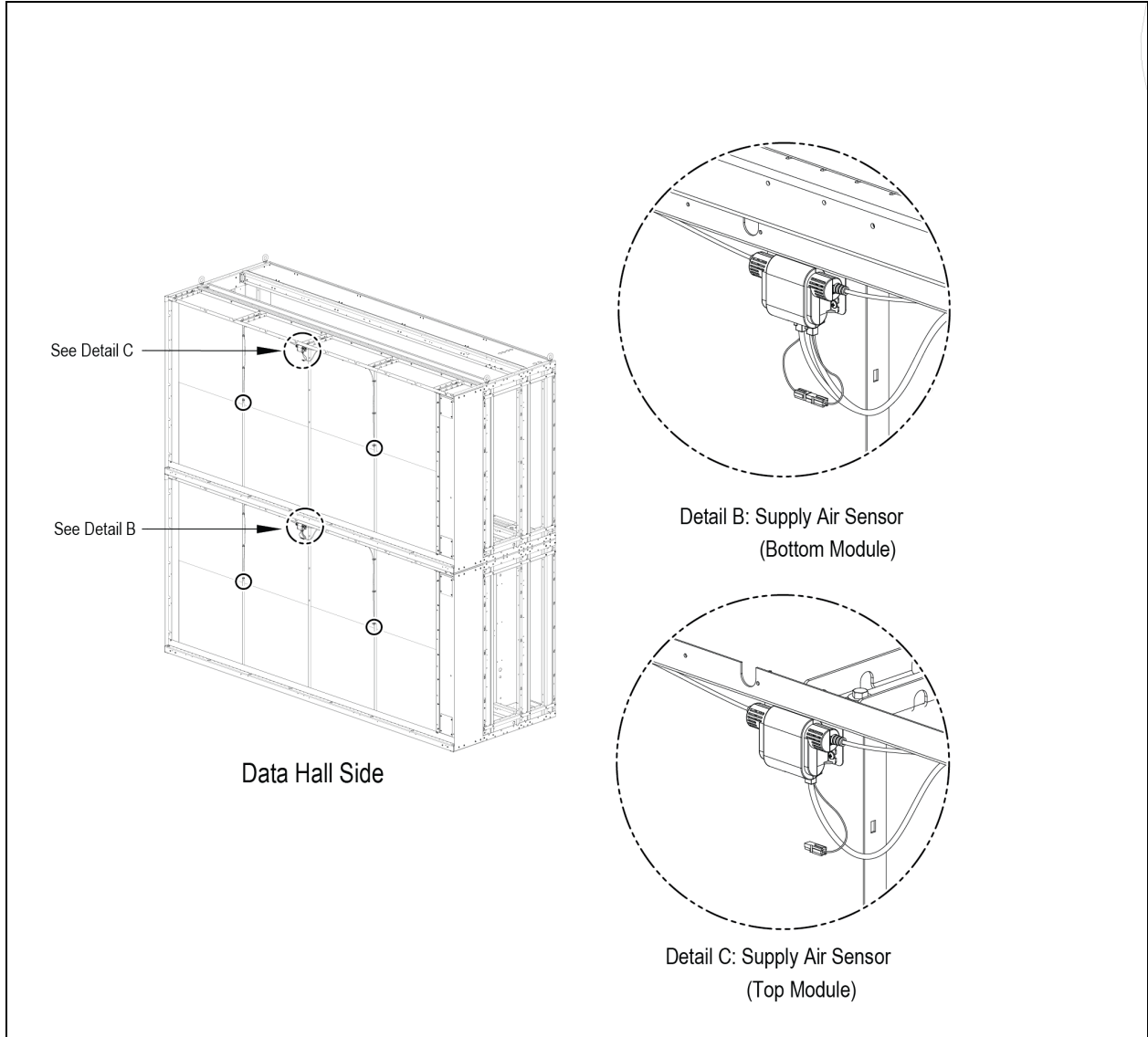

NOTE: The unit installed sensor captures data from a single point on the coil, which may significantly differ from the average air temperature due to varying operational conditions such as inlet temperature, coil loading and fan speed. In order to improve the supply temperature reading accuracy, it is suggested to:

- Control based on return air temperature, which offers a better representation of the system's average air temperature.
- Install remote sensors downstream of the unit.
- Use multiple sensors distributed across the rack or row level to aggregate a more representative airflow temperature.

6 Piping Requirements

All fluid connections to the unit, with the exception of the condensate drain, are sweat copper, optional flanged or optional grooved connections. Factory installed piping brackets must not be removed. Field installed piping must be installed in accordance with local codes and must be properly assembled, supported, isolated and insulated. Avoid piping runs through noise sensitive areas, such as office walls and conference rooms.

Refer to specific text and detailed diagrams in this manual for other unit specific piping requirements.

The pipe connection locations, piping general arrangement and schematics are described in the submittal documents included in the [Submittal Drawings](#) on page 77 .

Relevant documents are referenced below by number and title.

Table 6.1 Piping Connection Drawings

Document Number		Title
CA60	CA80	
20000800	20000253	Primary Connection Locations with Brazed Customer Connections
20000776	20000254	Primary Connection Locations with Flanged Customer Connections
-	20000566	Primary Connection Locations with Grooved Customer Connections
20000788	20000759	Top and Bottom Module Assembly, Internal Condensate Drain Line Connection
20000789	20000761	Field Gravity Drain Connection

6.1 Drain Fluid Connections

NOTICE

Risk of water leakage. Can cause severe property damage and loss of critical data center equipment.

The Vertiv™ CoolLoop Thermal Wall requires a water drain connection. Improper installation, application and service practices can result in water leakage from the unit.

Do not locate the unit directly above any equipment that could sustain water damage.

We recommend installing monitored leak detection equipment for the water supply lines and the internal unit water lines.

The following pipe connections are required:

- A drain line from the unit.
- Supply and return water lines.

Table 6.2 Internal Water Volume

Model	Volume
	Gallons (liters)
CA60 4 row	58.42 (221.1)
CA60 6 row	75.83 (287)
CA60 8 row	93.24 (353)
CA80 Smart Coil	95.96 (363)
CA80 Next Generation Coil	95.96 (363)

6.1.1 Field Installed, Gravity Drain Line Requirements

NOTICE

Risk of water backing up in the drain line. Leaking and overflowing water can cause equipment and building damage.

Sagging condensate drain lines may inadvertently create an external trap.

A 3/4-in NPT female drain connection is provided on units without an optional condensate pump.

Observe the following requirements when installing and routing the drain line:

- The drain line must be sized for 2 gpm (7.6 l/m) flow.
- The drain line must be located so it will not be exposed to freezing temperatures.
- The drain should be the full size of the drain connection.
- The drain line must slope continuously away from the unit. Pitch drain line toward drain a minimum of 1/8 in. (3 mm) per 1 ft (305 mm) of length.
- The drain line must be rigid enough so that it does not sag between supports which unintentionally creates traps.
- The drain line must comply with all applicable codes.
- We recommend installing monitored, under floor leak detection equipment.

6.2 Chilled Water Loop Piping Guidelines



CAUTION: Risk of improper piping installation. Leak checking, fluid chemistry and fluid maintenance can cause equipment damage and personal injury. Installation and service of this equipment should be done only by qualified personnel who have been specially trained in the installation of air conditioning equipment and who are wearing appropriate, OSHA-approved PPE.

NOTICE

Risk of frozen pipes and corrosion from improper coolant mixture. Can cause water leaks resulting in equipment and building damage.

When the cooling unit or piping may be exposed to freezing temperatures, charge the system with the proper percentage of glycol and water for the coldest design ambient temperature. Automotive antifreeze is unacceptable and must NOT be used in any glycol fluid system. Use only HVAC glycol solution that meets the requirements of recommended industry practices. Do not use galvanized pipe.

NOTICE

Risk of piping system corrosion and freezing fluids. Can cause leaks resulting in equipment and very expensive building damage. Cooling coils and piping systems are at high risk of freezing and premature corrosion. Fluids in these systems must contain the proper antifreeze and inhibitors to prevent freezing and premature coil and piping corrosion. The water of water/glycol solution must be analyzed by a competent local water treatment specialist before start up to establish the inhibitor and antifreeze solution and at regularly scheduled intervals throughout the life of the system to determine the pattern of inhibitor depletion.

The complexity of water/glycol solution condition problems and the variations of required treatment programs make it extremely important to obtain the advice of a competent and experienced water treatment specialist and follow a regularly scheduled coolant fluid system maintenance program.

Water chemistry varies greatly by location, as do the required additives, called inhibitors, that reduce the corrosive effect of the fluids on the piping systems and components. The chemistry of the water used must be considered, because water from some sources may contain corrosive elements that reduce the effectiveness of the inhibited formulation. Sediment deposits prevent the formation of a protective oxide layer on the inside of the coolant system components and piping. The water/coolant fluid must be treated and circulating through the system continuously to prevent the buildup of sediment deposits and/or growth of sulfate reducing bacteria.

Proper inhibitor maintenance must be performed in order to prevent corrosion of the system. Consult glycol manufacturer for testing and maintenance of inhibitors.

Commercial ethylene glycol, when pure, is generally less corrosive to the common metals of construction than water itself. It will, however, assume the corrosivity of the water from which it is prepared and may become increasingly corrosive with use if not properly inhibited.

We recommend installing a monitored fluid detection system that is wired to activate the automatic closure of the field-installed coolant fluid supply and return shutoff valves to reduce the amount of coolant fluid leakage and consequential equipment and building damage. The shutoff valves must be sized to close off against the maximum coolant fluid pressure in case of a catastrophic fluid leak.

NOTICE

Risk of no flow condition. Can cause equipment damage.

Do not leave the water/coolant fluid supply circuit in a no-flow condition. Idle fluid allows the collection of sediment that prevents the formation of a protective oxide layer on the inside of tubes. Keep unit switched On and water/coolant fluid supply circuit system operating continuously.

Refer to the appropriate piping general-arrangement schematics for your system for the recommended, field-installed hardware such as shutoff valves. See **Table 6.1** on page 41.

- For brazed connection units, use copper piping with a brazing alloy with a minimum temperature of 1350°F (732°C), such as Sil-Fos. Avoid soft solders, such as 50/50 or 95/5. The brazed sleeves are provided and stored behind the filter rack and in front of the fans. See **Table 6.1** on page 41
- The flanged connection is a 4-1/8" flange.
- The grooved connection is a 4" coupling.
- Follow local piping codes and safety codes.
- Qualified personnel must install and inspect system piping.
- The water/glycol cooled system will operate in conjunction with a cooling tower, city water or drycooler.
- Contact a local water consultant regarding water quality, corrosion protection and freeze-protection requirements.
- Install manual shut off valves at the supply and return line to each unit to permit routine service and emergency isolation of the unit.
- Install a monitored, fluid detection system that is wired to activate the automatic closure of field installed coolant fluid supply and return shut off valves to reduce the amount of coolant fluid leakage and consequential equipment and building damage. The shut off valves must be sized to close off against the maximum coolant fluid system pressure in case of a catastrophic fluid leak.

6.2.1 Flanged Connections

For specifications on the flange used, please refer to [Flange Specifications](#) on page 75 .

Checking Flange Condition

1. Check the condition of the flange faces for scratches, dirt, and scale.
2. Check for corrosion pitting and tool marks.
3. Inspect the gasket seating surfaces.
4. Check the areas on the flange where the nuts will seat. These areas should be flat and free from pitting and excessive wear.
5. Confirm that the flange is corrosion free and undamaged.

Flange Alignment between Vertiv™ CoolLoop Thermal Wall and Field Supplied Flange

1. Visually examine the flange alignment to ensure that an acceptable fit has been obtained.
2. While aligning flanges, make sure that there are no residual stresses in the joint. The use of heat correction for the alignment of flanges is strictly prohibited.
3. Flange faces should be parallel and aligned.
4. The flange bolt holes should be in line so that bolts will pass freely.

Nuts and Bolts Check

1. Visually examine the nuts, studs, and bolts before installation to ensure that they are free from defects such as corrosion and damaged threads. Nuts or bolts with damaged threads should not be used.
2. Check the length of the stud or bolt to avoid short bolting and excessive threads. Flange bolts shall be furnished in a sufficient length to allow use of bolt tensioning equipment or spades, spaces, drip rings and water valves, and the associated extra gaskets.
3. Visually examine studs and nuts after cleaning to ensure that they are free from burrs. Studs and nuts shall be cleaned using a wire brush to remove any dirt on the threads. Lubricant shall be applied on threads and nuts to flange contact surfaces. Lubricant shall not be used in the gasket and in the gasket seating area.
4. The bolt and nut material grades should be correctly identified before they are used.
5. Bolts and nuts can only be re-used if it is known that they have not been overloaded or have not exceeded their yield point.
6. When assembling the nut on the bolt, the nut identification marking must always point outwards.

Gasket Check

1. Do not use sealing compound, grease, or other paste or adhesive on the gasket or flange faces.
2. Do not force the gasket into the gasket seat between the mating flange faces during insertion.
 - a. Once the gasket is seated, bring the mating flanges together carefully without shaking the gasket off the seat.
 - b. Then install all studs and run up all nuts hand-tight.
3. Visually examine gaskets before installation to ensure that they are free from defects.
4. Color coding shall be maintained per the rate and type of gasket provided by the manufacturer.
5. Clean the gasket seating by using a wire brush.

6. Make sure the material is as specified. Look for any possible defects or damage in the gasket such as folds or creases.
7. Soft material gaskets should be replaced with new ones whenever an opened joint is to be closed again.
8. The full face flange gasket shall only be used once.

Flange Bolt Torque Sequence

Follow industry standards when assembling torque bolts and nuts in a criss-cross sequencing using a minimum of three torquing passes.

After the three basic passes are completed, repeat criss-cross sequence until no further rotation of the nut is observed.

Field flange connection to the Vertiv™ CoolLoop Thermal Wall unit must be installed in accordance with local codes and best industry practice.

6.2.2 Grooved Connections

Grooved Coupling Condition Check

1. Check the condition of the grooved coupling for scratches, dirt, and scale.
2. Check for corrosion pitting and tool marks.
3. Inspect the gasket seating surfaces.
4. Check the areas on the grooved coupling where the nuts will seat. These areas should be flat and free from pitting and excessive wear.
5. Confirm that the grooved coupling is corrosion free and undamaged.

Grooved coupling installation procedure

Pipe Ends Check

1. Make sure that the outside surface between the groove and the end is smooth and clean.
2. Remove any residual of oil, grease, dirt, and particles.
3. Apply a thin coat of suitable lubricant or silicone lubricant to the gasket lips and exterior for lubrication.

Figure 6.1 Pipe Ends Check



Gasket Insertion

1. Insert the gasket over the end of one of the two pipes to be joined.

Figure 6.2 Gasket Insertion

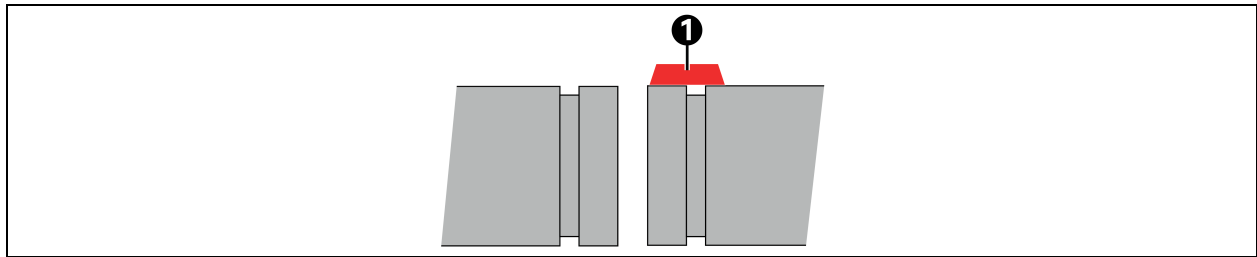

Item	Description
1	Gasket

2. Make sure that the gasket lip does not overhang the end of the copper pipe.

Joining Ends

1. Bring together the two pipe ends and align them.
2. Slide the gasket into position, and make sure that it is centered between the grooves.

Figure 6.3 Joining Ends

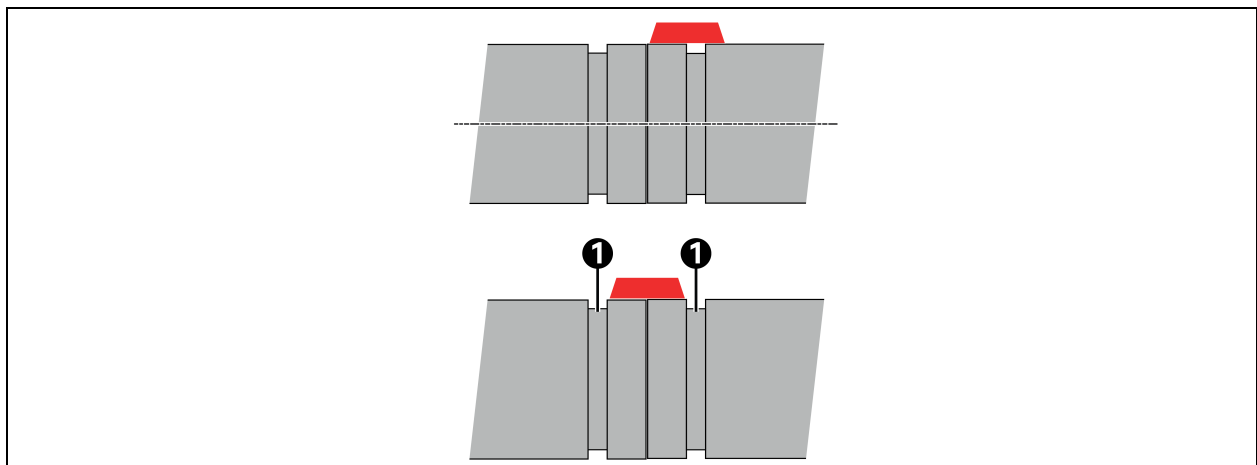

Item	Description
1	Grooves

3. Make sure that no portion of the gasket extends into the grooves.

Joining Pipes

1. Insert the housing over the gasket.
2. Screw the bolts loosely, just enough to hold together the two parts of the housing.

Figure 6.4 Joining Pipes

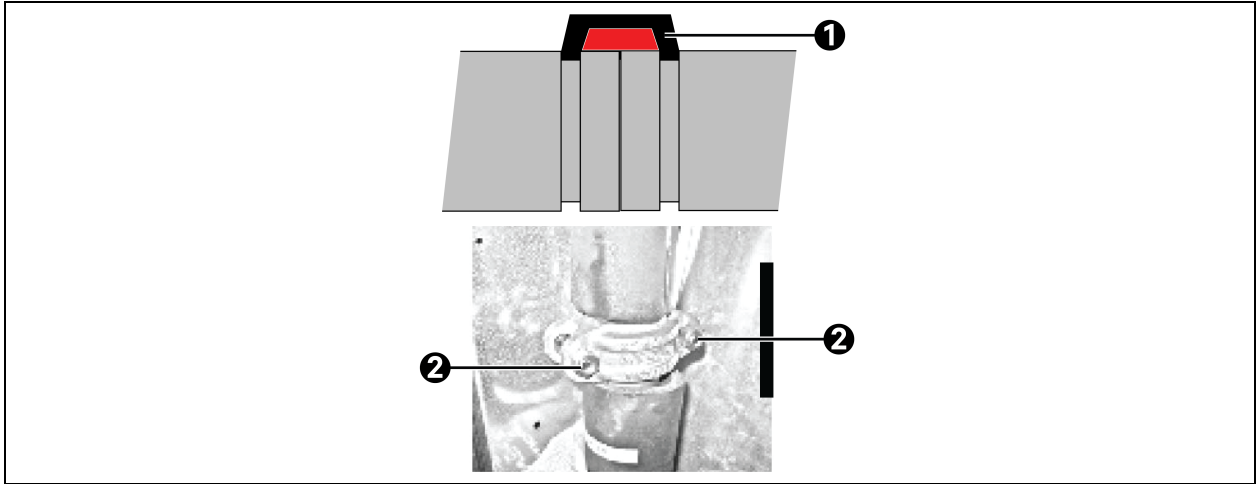

Item	Description
1	Housing
2	Bolts

3. Make sure that the gasket is not rolled or pinched.
4. Make sure the housing engages the grooves properly on both pipes.
5. Tighten all nuts evenly by alternating sides until metal-to metal contact occurs at both bolt pads.

NOTE: Tightening the nuts evenly is important to prevent gasket pinching.

NOTICE

Leakage may occur if the gasket is pinched or damaged.

6. Make sure the offsets are equal at the bolt pads. This is necessary to ensure a rigid joint.

Figure 6.5 Offsets

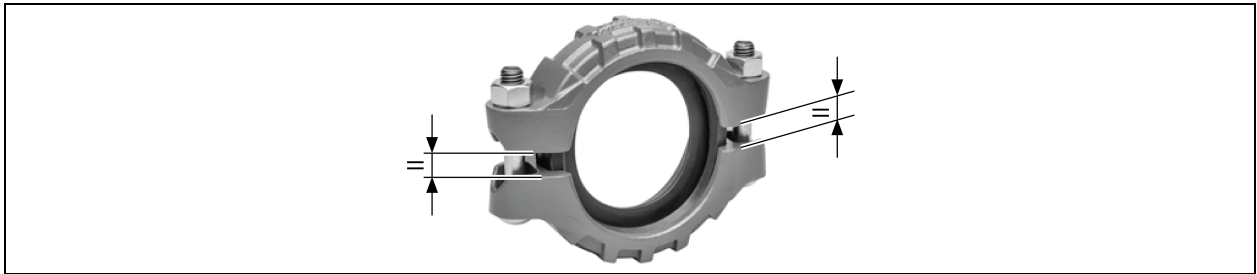

7. Visually inspect the bolt pads at each joint to ensure metal to metal contact is achieved.
8. Cover the connection with insulation.

Figure 6.6 Insulation

Field grooved coupling connection to the Vertiv™ CoolLoop Thermal Wall unit must be installed in accordance with local codes and best industries practice. For additional grooved connection specifications, refer to the last page of the document 20000566.

6.2.3 Leak Checking for Unit and Field Installed Piping

The fluid systems in the Vertiv™ CoolLoop Thermal Wall are factory checked for leaks and may be shipped with holding charge. At installation, check all fluid circuits for leaks.

NOTE: We recommend isolating the unit with field-installed shutoff valves during leak checking of field-installed piping. When the units are included in a leak test, use of fluid for pressure testing is recommended. When pressurized gas is used for leak testing the unit, the maximum recommended pressure is 30 psig (207 kPa) and tightness of the unit should be verified by pressure decay over time, (<2 psig/hour [13.8 kPa/hour]) or sensing a tracer gas with suitable instrumentation. Dry seals in fluid valves and pumps may not hold a high gas pressure.

This page intentionally left blank

7 Checklist for Completed Installation

7.1 Moving and Placing Equipment

1. Unpack and check received material.
2. Install Optional Damper Kit if available.
3. Assemble top and bottom module together.
4. Ensure proper vertical alignment between top and bottom modules. See [Final Installation](#) on page 32.
5. Proper clearance for service access has been maintained around the equipment.
6. Equipment is level and mounting fasteners are tight.

7.2 Electrical Installation Checks

1. Supply voltage and phase matches equipment nameplate.
2. Power wiring connections completed to the disconnect switch and unit.
3. Power line circuit breakers or fuses have proper ratings for equipment installed.
4. All internal and external high and low voltage wiring connections are tight.
5. Confirm that unit is properly grounded to an earth ground.
6. Control transformer setting matches incoming power.
7. Electrical service conforms to national and local codes.
8. Check blowers for proper rotation.

7.3 Piping Installation Checks

1. Piping completed to coolant loop.
2. Piping has been leak checked.
3. Piping has been flushed to clear debris, pipe dope, and contaminants.
4. Piping is properly sized.
5. Check piping inside and outside of equipment for proper support and adequate spacing to prevent rub through.
6. Ensure that factory clamps have been reinstalled.
7. Internal drain line is connected and is not obstructed.
8. External drain line is pitched per local code and is connected to floor drain.

7.4 Other Installation Checks

1. Filters installed.
2. Check fasteners that secure motors—some may have become loose during shipment.
3. All fans are free of debris.

This page intentionally left blank

8 Initial Start Up Checks and Commissioning Procedure for Warranty Inspection



WARNING! Arc flash and electric shock hazard. Open all local and remote electric power supply disconnect switches, verify with a voltmeter that power is Off and wear appropriate, OSHA-approved personal protective equipment (PPE) per NFPA 70E before working within the electric control enclosure. Failure to comply can cause serious injury or death. Customer must provide earth ground to unit, per NEC, CEC and local codes, as applicable. Before proceeding with installation, read all instructions, verify that all the parts are included and check the nameplate to be sure the voltage matches available utility power. The Vertiv™ iCOM™ controller does not isolate power from the unit, even in the Unit Off mode. Some internal components require and receive power even during the Unit Off mode of the controller. The only way to ensure that there is NO voltage inside the unit is to install and open a remote disconnect switch. Refer to unit electrical schematic. Follow all local codes.



WARNING! Risk of electric shock. Can cause equipment damage, injury or death. Open all local and remote electric power supply disconnect switches and verify with a voltmeter that power is off before working within any electric connection enclosures. Installation, service, and maintenance work must be performed only by properly trained and qualified personnel and in accordance with applicable regulations and manufacturers' specifications. Opening or removing the covers to any equipment may expose personnel to lethal voltages within the unit even when it is apparently not operating and the input wiring is disconnected from the electrical source.



WARNING! Risk of improper wiring, piping, moving, lifting and handling. Can cause equipment damage, serious injury or death. Installation and service of this equipment should be done only by qualified personnel who have been specially trained in the installation of air conditioning equipment and who are wearing appropriate, OSHA-approved PPE.

- Confirm that all items on [Checklist for Completed Installation](#) on page 51 have been done.
- Locate the Vertiv™ CoolLoop Thermal Wall Warranty Inspection Check Sheet in the unit's electric panel.
- Complete Vertiv™ CoolLoop Thermal Wall Warranty Inspection Check Sheet during start up.
- Forward the completed Vertiv™ CoolLoop Thermal Wall Warranty Inspection Check Sheet to your local sales office. **This information must be completed and forwarded to validate warranty.**
- Contact your local sales representative or technical support if you have any questions or problems during unit start up and commissioning. Visit <https://www.Vertiv.com/en-us/support/> or call 1-800-222-5877 for contacts.

This page intentionally left blank

9 Maintenance



WARNING! Arc flash and electric shock hazard. Open all local and remote electric power supply disconnect switches, verify with a voltmeter that power is Off and wear appropriate, OSHA-approved personal protective equipment (PPE) per NFPA 70E before working within the electric control enclosure. Failure to comply can cause serious injury or death. Customer must provide earth ground to unit, per NEC, CEC and local codes, as applicable. Before proceeding with installation, read all instructions, verify that all the parts are included and check the nameplate to be sure the voltage matches available utility power. The Vertiv™ iCOM™ controller does not isolate power from the unit, even in the Unit Off mode. Some internal components require and receive power even during the Unit Off mode of the controller. The only way to ensure that there is NO voltage inside the unit is to install and open a remote disconnect switch. Refer to unit electrical schematic. Follow all local codes.



WARNING! Risk of electric shock. Can cause equipment damage, injury or death. Open all local and remote electric power supply disconnect switches and verify with a voltmeter that power is off before working within any electric connection enclosures. Installation, service, and maintenance work must be performed only by properly trained and qualified personnel and in accordance with applicable regulations and manufacturers' specifications. Opening or removing the covers to any equipment may expose personnel to lethal voltages within the unit even when it is apparently not operating and the input wiring is disconnected from the electrical source.



WARNING! Risk of improper wiring, piping, moving, lifting and handling. Can cause equipment damage, serious injury or death. Installation and service of this equipment should be done only by qualified personnel who have been specially trained in the installation of air conditioning equipment and who are wearing appropriate, OSHA-approved PPE.



WARNING! Risk of electric shock. Can cause serious injury or death. The Vertiv™ iCOM™ microprocessor does not isolate power from the unit, even in the "Unit Off" mode. Some internal components require and receive power even during the "unit off" mode of the Vertiv™ iCOM™ control. Open all local and remote electric power disconnect switches and verify with a voltmeter that power is Off before working on any component of the system.

The Vertiv™ CoolLoop Thermal Wall is a facility heat removal system that consists of a top and bottom module that is assembled in the field.

- Good maintenance practices are essential to minimizing operation costs and maximizing product life.
- Read and follow monthly and semi-annual maintenance schedules included in this manual. These MINIMUM maintenance intervals may need to be more frequent based on site specific conditions.
- See the Vertiv™ iCOM™ user manual, SL-31075, available at www.Vertiv.com for instructions on using the controller to predict some service maintenance intervals.
- We recommend the use of trained and authorized service personnel, extended service contracts, and factory-specified replacement parts. Contact your Vertiv sales representative.

NOTE: Refer to the submittal 20000780 for CA60 and 20000756 for CA80 for installation and service clearance. The indicated service clearance are intended for regular maintenance operations. The optional damper is accessible only on Data Hall Side.

9.1 Filters

NOTICE

Risk of improper filter installation. Can cause filter collapse and air flow reduction.

To maximize the performance and reliability of the equipment, use only Vertiv filters. Contact your Vertiv representative to order replacement filters.

Verify that filters are installed and positioned so that air flow direction marked on the filter is the same direction as unit air flow.

Table 9.1 Filter Quantity and Type

Unit Size	Filter Type	Quantity
CA60 - Bottom (Base) Module	MERV 8 (optional MERV 11)	15 (filter dimensions 20 x 24 x 4)
CA60 - Top Module	MERV 8 (optional MERV 11)	18 (filter dimensions 20 x 24 x 4)
CA80 - Bottom (Base) Module	MERV 8 (optional MERV 11)	18 (filter dimensions 20 x 24 x 4) and 3 (filter dimensions 16 x 24 x 4)
CA80 - Top Module	MERV 8 (optional MERV 11)	21 (filter dimensions 20 x 24 x 4) and 3 (filter dimensions 16 x 24 x 4)

9.1.1 Replacing the Filters



WARNING! Risk of contact with high speed rotating fan blades. Can cause serious injury or death. Open all local and remote electric power supply disconnect switches, verify with a voltmeter that power is off, and verify that all fan blades have stopped rotating before working in the unit cabinet or on the fan assembly. If control voltage is applied, the fan motor can restart without warning after a power failure. Do not operate the unit with any or all cabinet panels removed.

1. The filters are accessed through the gallery side of the module. See **Figure 9.1** on the facing page.
2. Remove and install the filters up and down in the columns. There are three filters in each column. See Submittal 20000785 for CA60 and 20000755 for CA80.

Figure 9.1 Filter Location, Gallery Side of Modules

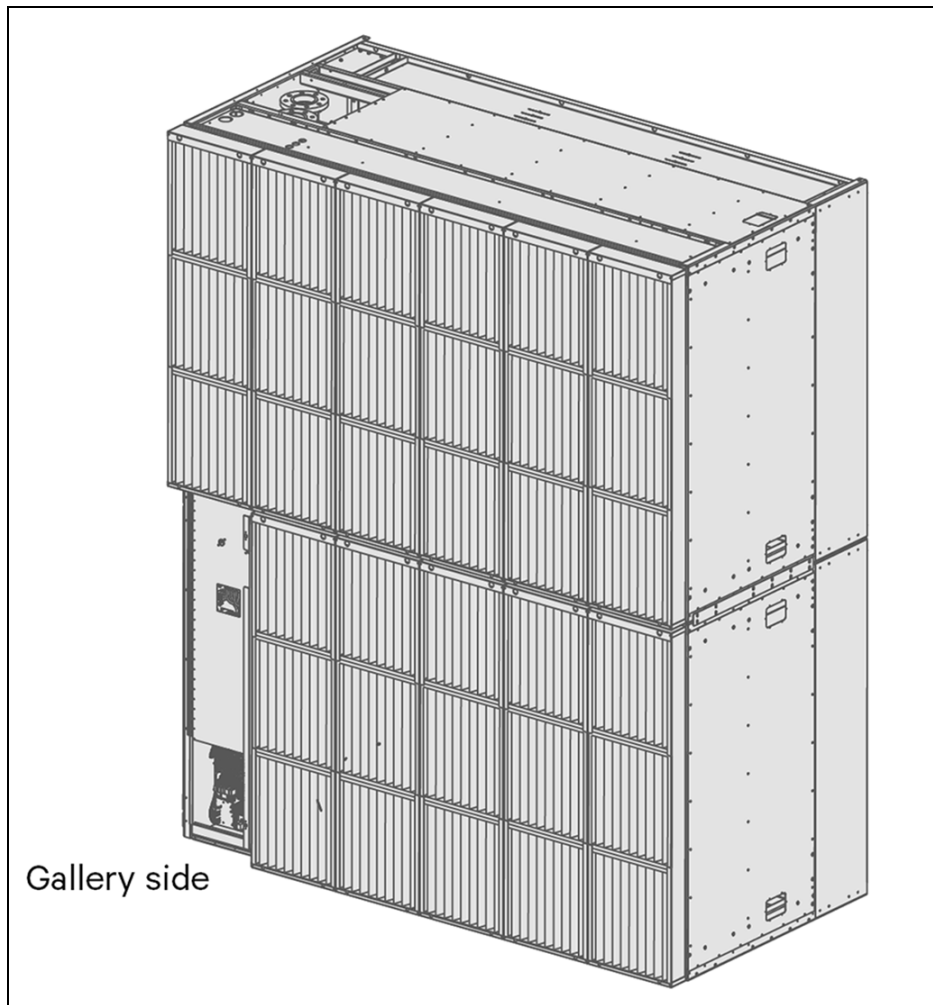

NOTE: The unit shown is the CA60.

9.2 Fan Maintenance

9.2.1 Fan Assembly Troubleshooting

Any safety hazards stemming from the device must be re-evaluated once it is installed in the end device.

Do not make any modifications, additions or conversions to the fan assembly without the approval of Vertiv.



WARNING! Risk of electric shock. Can cause serious injury or death. Open all local and remote electric power supply disconnect switches and verify with a voltmeter that power is off before opening the fan motor electric-connection enclosure. Fan motor controls can maintain an electric charge for 10 minutes after power is disconnected. Wait 10 minutes after power is verified as off before working within the electric control connection enclosures. Use only fully-trained and qualified HVAC technicians to perform maintenance on the fans.



WARNING! Risk of contact with high speed rotating fan blades. Can cause serious injury or death. Open all local and remote electric power supply disconnect switches, verify with a voltmeter that power is off, and verify that all fan blades have stopped rotating before working in the unit cabinet or on the fan assembly. If control voltage is applied, the fan motor can restart without warning after a power failure. Do not operate the unit with any or all cabinet panels removed.



CAUTION: Risk of exposure to harmful noise levels. Can cause hearing injury or loss. Depending on the installation and operating conditions, a sound pressure level greater than 70 dB(A) may arise. Take appropriate technical safety measures. Operating personnel must wear appropriate, OSHA-approved PPE and observe all appropriate hearing-protection safety requirements.



CAUTION: Risk of contact with hot surfaces. Can cause injury. The fan motor, and some electrical components are extremely hot during unit operation. Allow sufficient time for them to cool to a touch-safe temperature before working within the unit cabinet. Use extreme caution and wear appropriate, OSHA-approved PPE when working on or near hot components.

NOTICE

Risk of improper power supply connection. Can cause equipment damage and loss of warranty coverage.

Prior to connecting any equipment to a main or alternate power source (for example: backup generator systems) for start up, commissioning, testing, or normal operation, ensure that these sources are correctly adjusted to the nameplate voltage and frequency of all equipment to be connected. In general, power source voltages should be stabilized and regulated to within $\pm 10\%$ of the load nameplate nominal voltage. Also, ensure that no three-phase sources are single phased at any time.

NOTE: Do not assume that the fan blades will not start to spin. If the motor is in a fault condition, it will safely shut down. Once the fault condition is cleared, there are certain conditions in which the motor will automatically resume operation.

9.2.2 Fan Impellers

Fan impellers should be periodically inspected and any debris removed. Check to ensure that the impellers can rotate freely.

Consult the factory for fan assembly maintenance and removal instructions.

9.2.3 Backdraft Barrier Kits

Backdraft barrier plates can be used to block airflow when fans are not in operation. If kit is required, contact your Vertiv sales rep. See submittal drawings for kit details.

Figure 9.2 High Airflow, High Efficiency Fan Backdraft Barrier Plate Kit

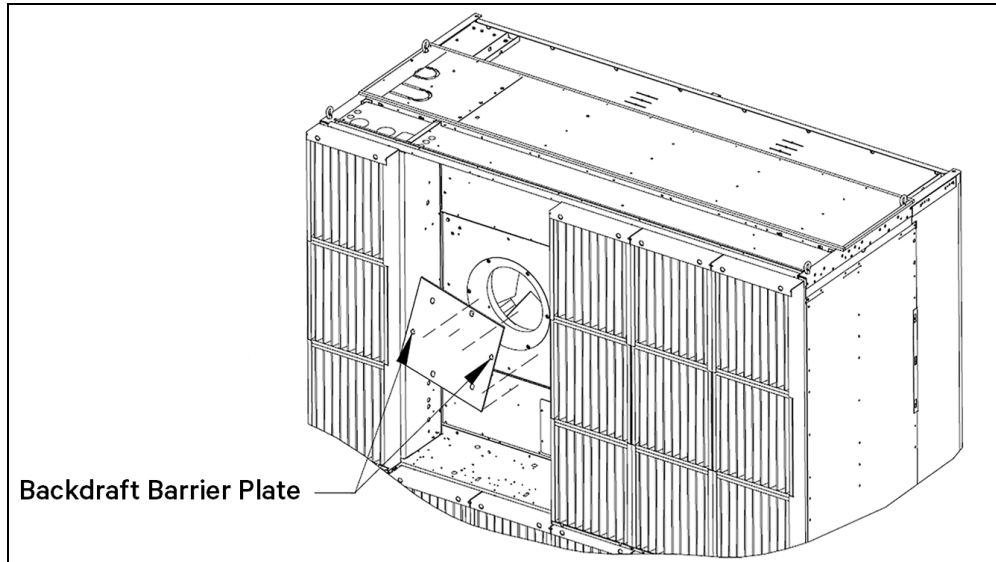

NOTE: The unit shown is the CA60.

Table 9.2 Backdraft Barrier Plate Drawings

Document Number	Fan Type
20000791	Backdraft Barrier Plate Kit - High Airflow, High Efficiency Fan for CA60
20000766	Backdraft Barrier Plate Kit - High Airflow, High Efficiency and Ultra Performance Fan for CA80

9.2.4 Removing Fan Assembly

Do not attempt to remove the fan assemblies without first contacting Vertiv Technical Support at 1-800-222-5877.



WARNING! Risk of very heavy 125-lb (56.7-kg) fan modules dropping downward suddenly. Can cause injury or death. Support fan modules before removing mounting hardware. Use caution to keep body parts out of the fan modules pathway during repositioning. Only properly trained and qualified personnel should work on this equipment.



CAUTION: Risk of improper handling of heavy and lengthy parts. Can cause personal injury and equipment damage. Follow relevant OSHA lifting recommendations and consider using a two-person lift for safe and comfortable removal and installation of cabinet panels. Only properly trained and qualified personnel wearing appropriate, OSHA-approved PPE should attempt to remove or install cabinet panels or components.

NOTE: We recommend using a duct lift or scissor lift when removing or installing the fan assemblies into the unit.

Equipment recommended to replace or install the new fans:

- Overhead winch or crane
 - Duct lift
 - Lift chains with hooks
 - Scissor lift
1. Turn unit off at the I/O switch, then turn disconnect off. Be sure proper lockout/tagout procedures are observed.
 2. Remove filter rack section. (See 20000785 for CA60 and 20000755 for CA80 included in [Submittal Drawings](#) on page 77 , for details on filter rack removal).
 3. Locate and remove the high and low voltage wiring from the fan. Reference the electrical schematic.

NOTE: Do not remove fan assembly using ladders. The fan assembly is removed using scissor lift or scaffolding.

4. How to uninstall a CoolLoop Thermal Wall fan module.
 - a. Loosen all the fasteners attaching the fan assembly to the unit, see [Figure 9.3](#) below.

Figure 9.3 Loosening Fasteners from the Fan Assembly

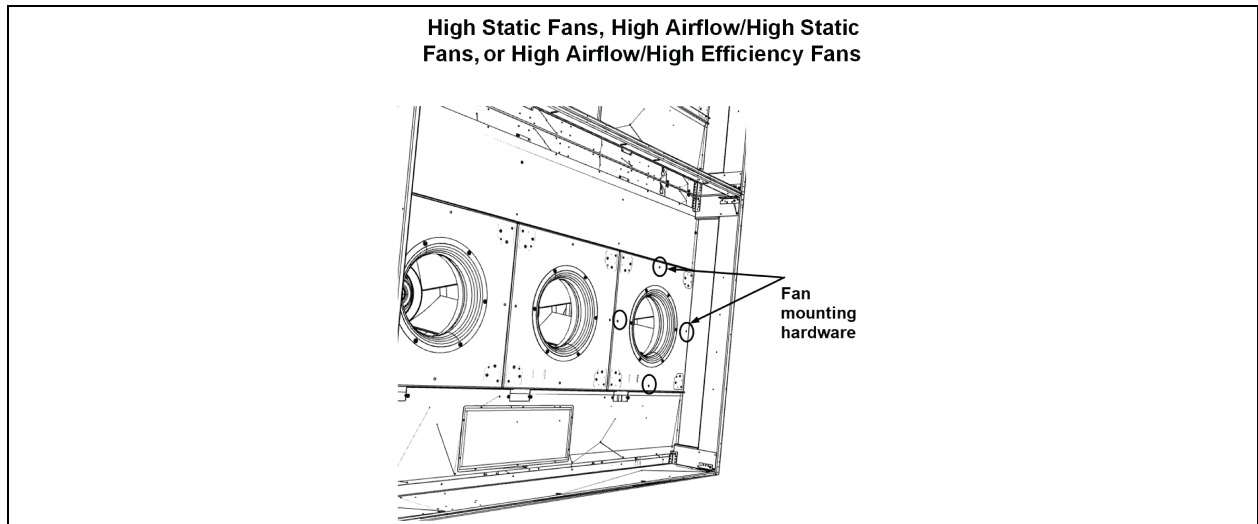

NOTE: The picture shows the CA60 unit. The CA80 unit has four fans per module.

- b. Disconnect all power and communication connectors to the fan module, see [Figure 9.4](#) on the facing page.

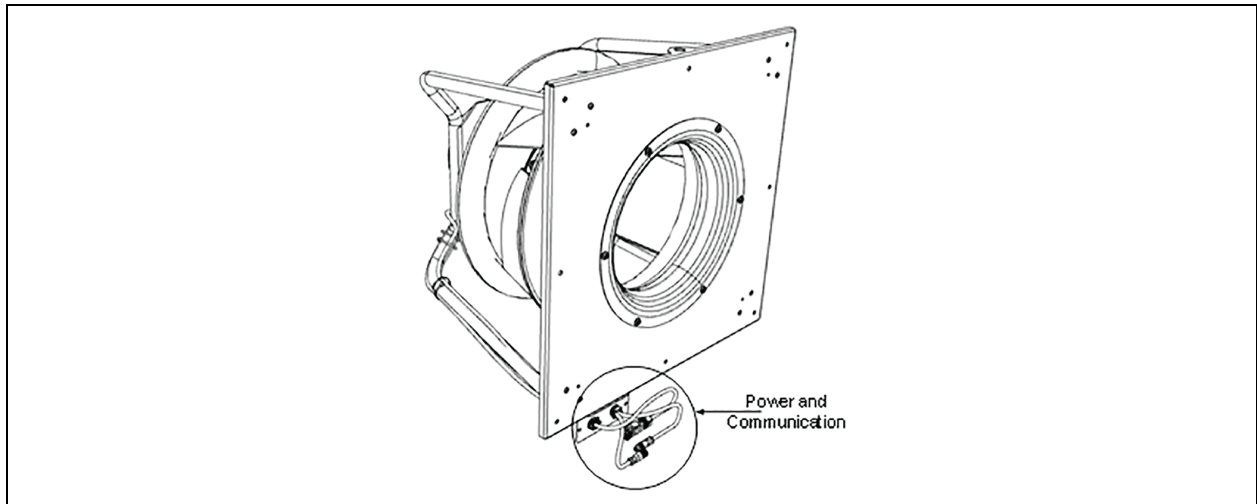
Figure 9.4 Power and Communication Connectors

- c. Take care not to damage the damper gasket behind the fan module.
5. Before you attempt to remove the fan module, locate the fan hoist mounting locations for the upper and lower module, see layout on **Figure 9.5** on the next page Also please reference **Figure 9.3** on the previous page and **Figure 9.4** above.

Figure 9.5 Lift Point for Top and Bottom Modules

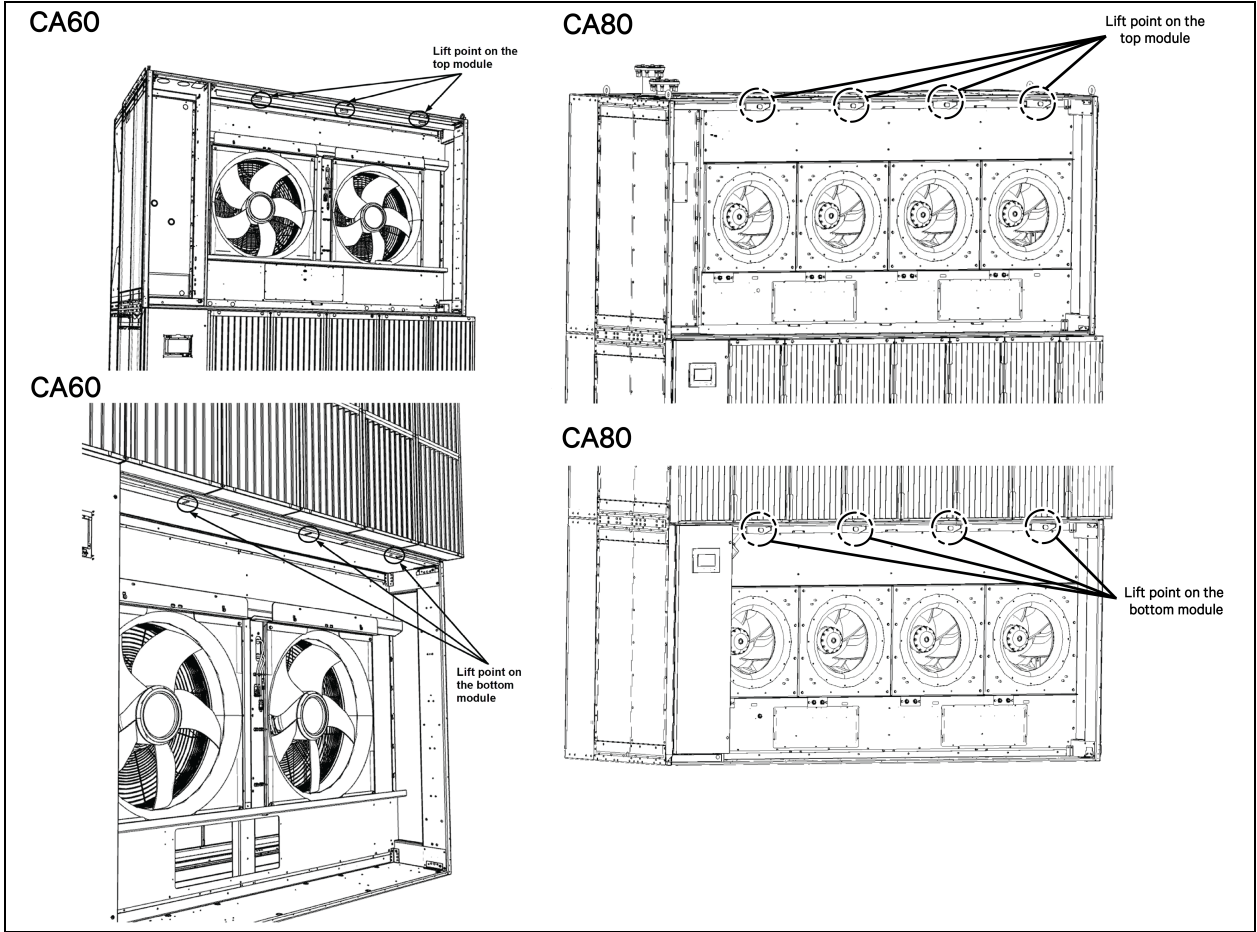

6. Attach the lift chains or straps to the hoist locations and to the fan module.
7. Removal steps for a unit equipped with high airflow, high efficiency fans:
 - a. While the supporting fan, tilt the fan out from the mounting point to reach the lift points.
 - b. Insert a strap or hooks into the lifting points to remove the fan, see **Figure 9.6** below.

Figure 9.6 Using Lifting Points to Remove High Airflow/High Efficiency Fans

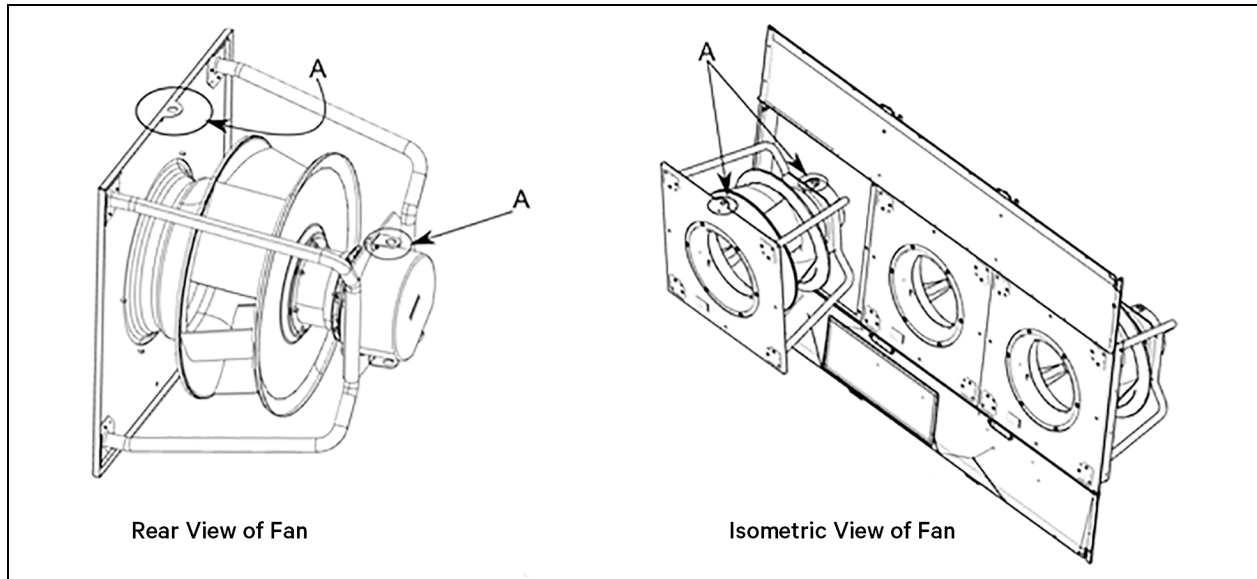

Item	Description
A	Lifting Points

8. Removal steps for unit equipped with an ultra performance fan:
 - a. While supporting the fan, tilt the fan out from the mounting point to reach the lift points.
 - b. Insert a strap or hooks into the lifting points to remove the fan.
 - c. Contact your service reference for detailed informations and procedures for an ultra performance fan removal.

Reinstalling Fan Assembly

1. Lift the new fan line up and install the top two bolts into the assembly.
2. Line up and install the bottom four bolts on the fan assembly to the unit.
3. Locate and connect the high and low voltage wiring from the fan to the unit.
4. Remove lockout/tagout and energize unit.
5. Complete Modbus addressing setup at the Vertiv™ Liebert® iCOM™ display for the replaced fan.
6. In the iCOM™ control, navigate to Service Menu > Auxiliary Device Setup > Modbus Devices > Modbus Fan menu.
 - a. Change the address of the replaced fan to 1 and enable the fans to operate using manual mode. This will enable high voltage power to the fans.
 - b. iCOM™ will communicate with the replaced fan at address 1. iCOM™ will automatically change the Modbus address to the correct value based on replaced fan location.

Figure 9.7 Clearance Dimensional Data

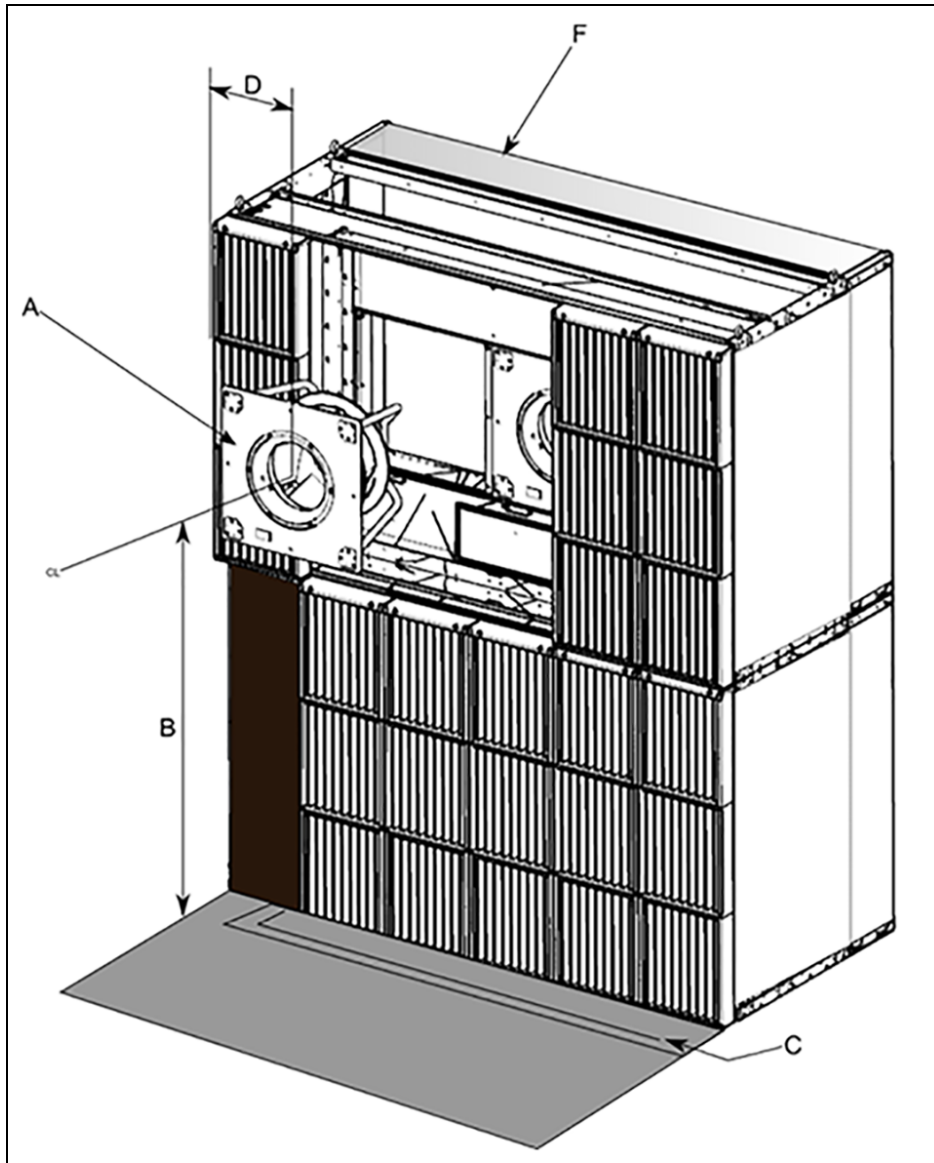

NOTE: The picture shows the CA60 unit.

Item	Description
A	Fan removal on gallery side
B	Varies depending on fan type and fan location, measured from the center line of fan to flow
C	Gravity drain line running in front of CoolLoop Thermal Wall
F	Chilled water coil, data hall side

9.3 Condensate Drain System Maintenance

9.3.1 Condensate Drain

Check for and clear obstructions in tubing during routine maintenance.

9.3.2 Condensate Pump



WARNING! Risk of electric shock. Can cause injury or death. Open all local and remote electric power supply disconnect switches and verify that power is Off with a voltmeter before working within the condensate pump electrical connection enclosure. The Vertiv™ Liebert® iCOM™ does not isolate power from the unit, even in the “Unit Off” mode. Some internal components require and receive power even during the “Unit Off” mode of the Vertiv™ Liebert® iCOM™.

To maintain the condensate pump:

1. Disconnect power to the unit using the disconnect switch.
2. Check for and clear obstructions in gravity lines leading to the condensate pump.
3. Remove the sump, clean with a stiff nylon brush and flush with water.
4. Inspect and clear clogs in the discharge check valve and float mechanism.
5. Reassemble and check for leaks.

9.3.3 Coil Drain Plug

If the coil needs to be drained or removed from site, use the standard practice to decommission a unit.

NOTE: Dimensional information regarding plug location is on 20000800 for CA60 and 20000253 for CA80 Primary Connection Locations with Brazed Connections and 20000776 for CA60 and 20000254 for CA80 Primary Connection Locations, with Flanged Customer Connections.

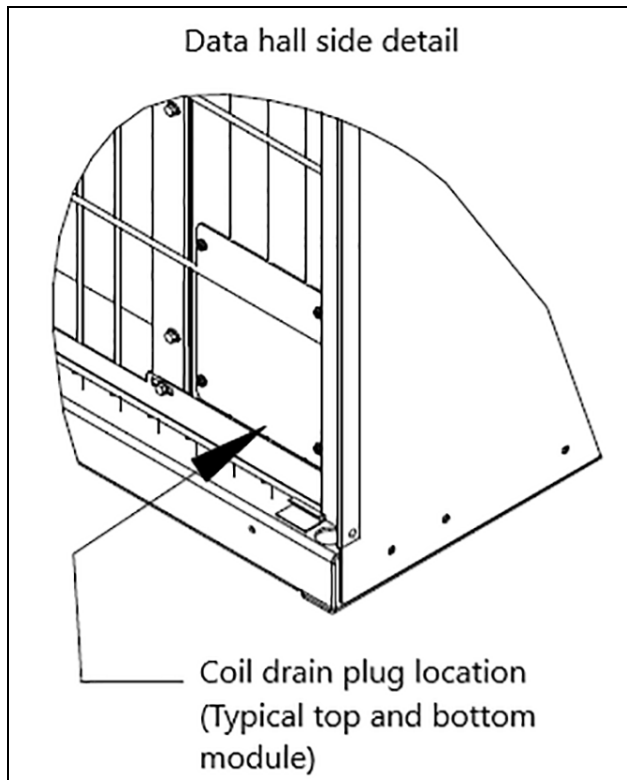
Figure 9.8 Coil Drain Plug Detail

9.3.4 Water Valves Actuator Maintenance

Remove the top module water piping closing panel to have access to the water valves actuators. Refer to the submittal 20000778 for CA60 and 20000251 for CA80 for the component location diagram. For detailed procedures for the water valve actuators maintenance and replacement contact your Vertiv service reference.

9.3.5 Optional Damper Actuator Maintenance

The maintenance on the optional damper kit can be done only on the data hall side. Refer to the submittal 20000768 for the damper installation. For detailed procedures for the optional damper actuator maintenance and replacement contact your Vertiv service reference.

9.3.6 Facility Fluid and Piping Maintenance

Maintaining the system fluid quality is required throughout the life of the system. Fluid and piping system maintenance schedules must be established and performed. A coolant fluid maintenance program must be established that will evaluate fluid chemistry and apply necessary treatment. The complexity of water/glycol solution condition problems and the variations of required treatment programs make it extremely important to obtain the advice of a competent and experienced water-treatment specialist and follow a regularly scheduled coolant fluid system maintenance program.

Perform periodic inspections of the facility and the unit coil and/or heat exchanger and coolant fluid piping system for leaks and visible damage.

9.3.7 Glycol Solution Maintenance

It is difficult to establish a specific schedule of inhibitor maintenance because the rate of inhibitor depletion depends upon local water conditions. Analysis of water samples at the time of installation and through a maintenance program should help to establish a pattern of depletion. A visual inspection of the solution and filter residue is often helpful in judging whether active corrosion is occurring. The complexity of water/glycol solution condition problems and the variations of required treatment programs make it extremely important to obtain the advice of a competent and experienced water treatment specialist and follow a regularly scheduled coolant fluid system maintenance program. It is important to note that improper use of water treatment chemicals can cause problems more serious than using none.

Proper inhibitor maintenance must be performed in order to prevent corrosion of the glycol system. Consult the glycol manufacturer for testing and maintenance of inhibitors. Do not mix products from different manufacturers.

This page intentionally left blank

10 Preventive Maintenance Checklist

Source: DPN002952, Rev. 4

Inspection Date	Job Name
Bottom Module Model #	Bottom Module Serial #
Top Module Model #	Top Module Serial #
Room Temperature/Humidity	° % Ambient Temperature

Not all units will have components. To determine your unit's configuration, compare the Indoor Unit # above and the information in [Nomenclature and Components](#) on page 7.

Good maintenance practices are essential to minimizing operation cost and maximizing product life. Read and follow all applicable maintenance checks listed below. At a minimum, these checks should be performed semi-annually. However, maintenance intervals may need to be more frequent based on site-specific conditions. Review the unit user manual for further information on unit operation. We recommend the use of trained and authorized service personnel, extended service contracts, and factory certified replacement parts. Contact your local sales representative for more details.

Check all that apply:

Evaporator/filters

- Check/replace filters.
- Grille area is unrestricted.
- Wipe section clean.
- Coil clean.
- Clean condensate pan.
- Clean trap in condensate drain.
- Check/test filter clog switch operation (if equipped).

Blower Section

Blower wheels are free of debris.

Check motor mount.

Check motor amp draw.

#1	L1	L2	L3
----	----	----	----

#2	L1	L2	L3
----	----	----	----

#3	L1	L2	L3
----	----	----	----

#4	L1	L2	L3
----	----	----	----

#5	L1	L2	L3
----	----	----	----

#6	L1	L2	L3
----	----	----	----

#7	L1	L2	L3
----	----	----	----

#8	L1	L2	L3
----	----	----	----

Condensate Pump (if equipped)

Check for debris in sump.

Check operation of floats (free movement).

Check/clean discharge check valve.

Electrical Panel

Check fuses.

Check contactors for pitting. Replace if pitted.

Check/re-torque wire connections.

Controls

- Check/verify control operation (sequence).

- Check/test change over device(s), if equipped.

- Check/test water detection device(s), if equipped.

- Check/test CAN connection between unit and sensors, if equipped.

- Check for loose electrical connections.

Chilled Water

- Verify proper water maintenance is being performed.

- Check coil and supply/return lines/connections for water/glycol leaks.

- Check/test water detection device(s), if equipped.

Appendices

Appendix A: Technical Support and Contacts

A.1 Technical Support/Service in the United States

Vertiv Group Corporation

24x7 dispatch of technicians for all products.

1-800-543-2378

Thermal Management Products

1-800-543-2378

Channel Products

1-800-222-5877

AC and DC Power Products

1-800-543-2378

A.2 Locations

United States

Vertiv Headquarters

505 N Cleveland Ave

Westerville, OH 43082

Europe

Via Leonardo Da Vinci 8 Zona Industriale Tognana

35028 Piove Di Sacco (PD) Italy

Asia

7/F, Dah Sing Financial Centre

3108 Gloucester Road

Wanchai, Hong Kong

This page intentionally left blank

Appendix B: Flange Specifications

Figure B.1 Flange Detail

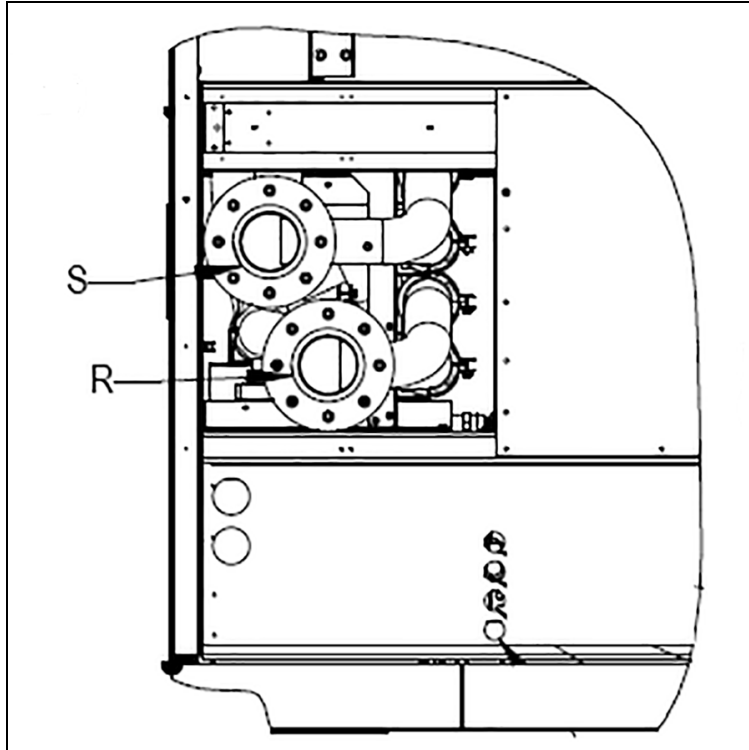

NOTE: The picture shows the CA60 unit.

For use with water.

Table B.1 Flange Specifications

Wrot/Steel Flange	
Shape	Straight
Type	2 piece wrot/epoxy floating flange
Class	150 lb.
Connection type	Copper tubing
Connection style	Socket connection X flanged
Flanged connection surface	Raised
Gender	Female
Pipe Size	4
Flange OD	9-in.
For bolt diameter	5/8-in.
Bolt Hole	

Table B.1 Flange Specifications (continued)

Diameter	3/4-in.
Number of	8
Bolt circle diameter	7-1/2-in.
Maximum Pressure	50 psi at 72°F
For Fitting	
Schedule	40
Material	Copper Body: Lead Free Uns C12200
	Steel Base: ASTM A36 Steel Plate
	Steel Base Coating: Dielectric
	Insulating Epoxy Coating
Specifications Met	ASME B16.22
Specifications	Conforms to NSF/ANSI 61 Annex G requirements
	Wrot copper sleeve manufactured to ASME B16.22
	Steel flange holes drilled to ANSI B16.5 specifications
	Temperature range from -66°F to 272°F
Flange Type/Torque Sequence	8 bolt flange/1,5,3,7,2,6,4,8
Torque the flange per standard practice for chilled water applications.	

Table B.2 Full Face Rubber Silicon Flange Gasket

For use with	WaterRef
For pipe size	8 (ANSI Class 150)
Thickness	1/16-in.
Color	Black

Appendix C: Submittal Drawings

Table C.1 Submittal Drawings Contents

Document Number		Title
CA60	CA80	
Component Location Drawings		
20000778	20000251	Component Location Diagram
Dimension Planning Drawings		
20000779	20000252	Cabinet and Anchor Dimensional Data, Bottom and Top Modules
20000780	20000756	Installation and Service Clearance
20000781	20000757	Floor Planning for Adjacent Units
20000782	20000751	Airflow Schematic
20000794	20000752	Piping Schematic
Seismic Drawings		
20000783	20000762	Seismic Application Assumptions and Requirements, IBC 0.75 Sds
20000784	20000763	Seismic Application Assumptions and Requirements, IBC 2.5 Sds
Filter and Rack Location		
20000785	20000755	Filter and Filter Rack Removal
Lag Screw Drawings		
20000786	20000758	Top and Bottom Module Assembly
Electrical Field Connection Drawings		
20000787	20000255	Electrical Field Connections, Bottom and Top Modules
20000760		Electrical Data (FLA, WSA, OPD)
20000800	20000253	Primary Connection Locations with Brazed Customer Connections
20000776	20000254	Primary Connection Locations with Flanged Customer Connections
-	20000566	Primary Connection Locations with Grooved Customer Connections
Automatic Transfer Switch (ATS)		
DPN005196		Auto Transfer Switch (ATS)
THD Transformer		
20000802	-	CA60 THD Mitigation High Airflow, High Efficiency Fan
-	20000764	CA80 THD Mitigation High Airflow, High Efficiency Fan
-	20000765	CA80 THD Mitigation Ultra Performance Fan
Unit to Unit Networking		
20000347		Vertiv™ Liebert® iCOMTM Unit to Unit Network Connections

Table C.1 Submittal Drawings Contents (continued)

Document Number		Title
CA60	CA80	
Temperature and Humidity Sensor		
-	20000769	Supply Air Sensors Connection
20000583		2T Rack Temperature sensor Connection
DPN000960		Remote Temperature and Humidity Sensor
Piping Connection Drawings		
20000800	20000253	Primary Connection Locations with Brazed Customer Connections
20000776	20000254	Primary Connection Locations with Flanged Customer Connections
-	20000566	Primary Connection Locations with Grooved Customer Connections
20000788	20000759	Top and Bottom Module Assembly, Internal Condensate Drain Line Connection
20000789	20000761	Field Gravity Drain Connection
Backdraft Barrier Plate Drawings		
20000791	20000766	Backdraft Barrier Plate Kit

CoolLoop Thermal Wall

CA60 COMPONENT LOCATION DIAGRAM WITH HIGH AIRFLOW / HIGH EFFICIENCY FAN OPTION

Item No.	Description
1	Chilled Water Coil (Typ. 2)
2	Fans (Qty. 6)
3	Air Filters (Typ. 33, Optional)
4	Electric Panel
5	Condensate Drain
6	Condensate Pump (Optional, located behind filters & fans)
7	THD Mitigation Device (Optional)
8	CW Connection location
9	High Voltage Electrical Knockout location
10	Filter Clog Switch (Supplied with optional filters)
11	Vertiv™ Liqui-Tect™ sensor (Optional, located behind filters)
12	Discharge Grill
13	Valve Sight Glass (Qty. 2)

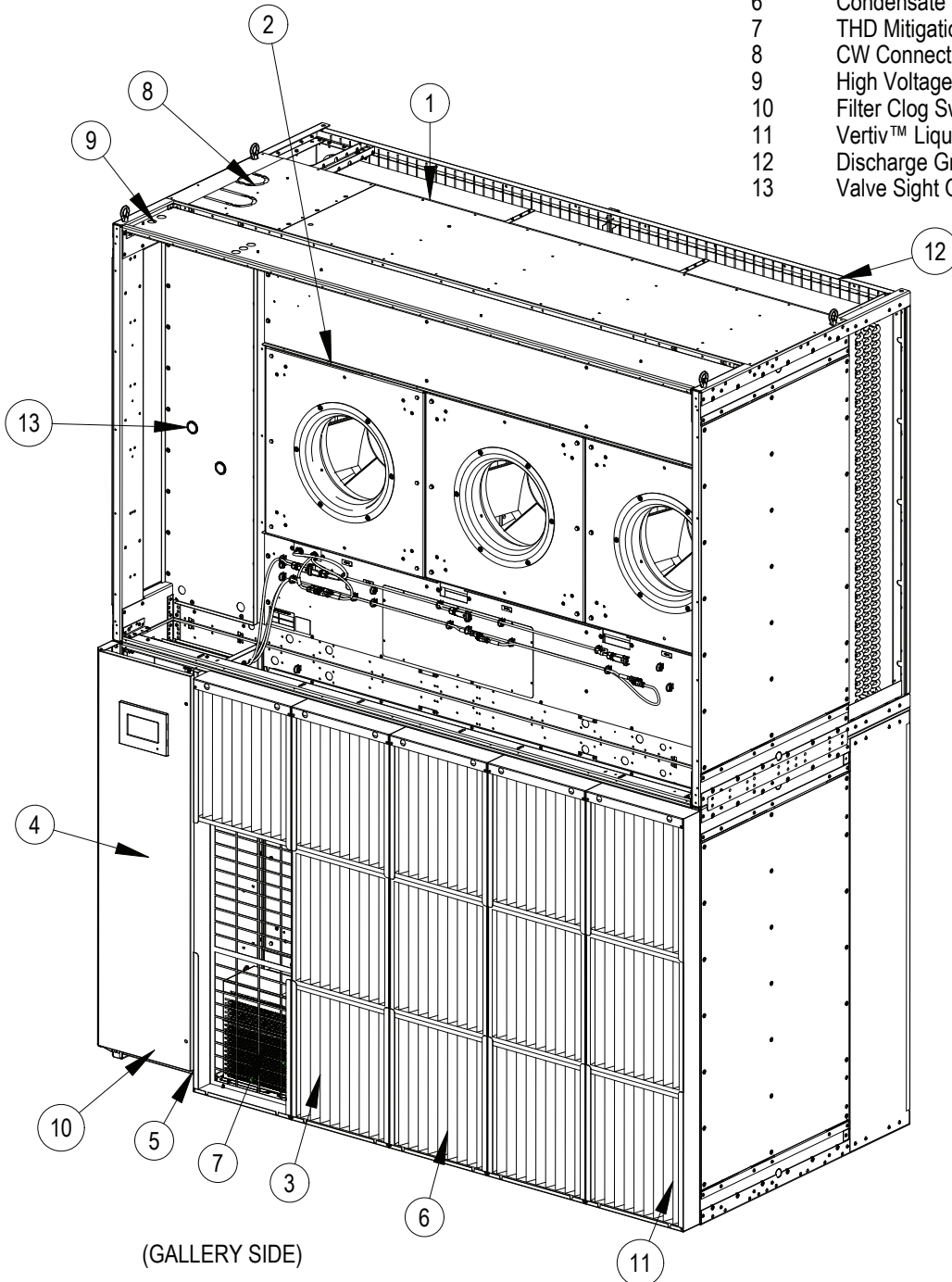

(DATA HALL SIDE)

Data Hall side
Detail.

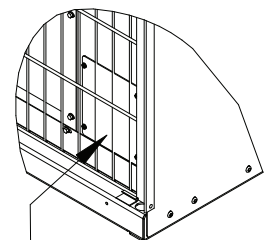

Coil drain plug location
(Typical lower right corner of
top & bottom modules)

Notes:
1. Some items not shown for clarity.

CoolLoop Thermal Wall

CA60 CABINET & ANCHOR DIMENSIONAL DATA BOTTOM AND TOP MODULES

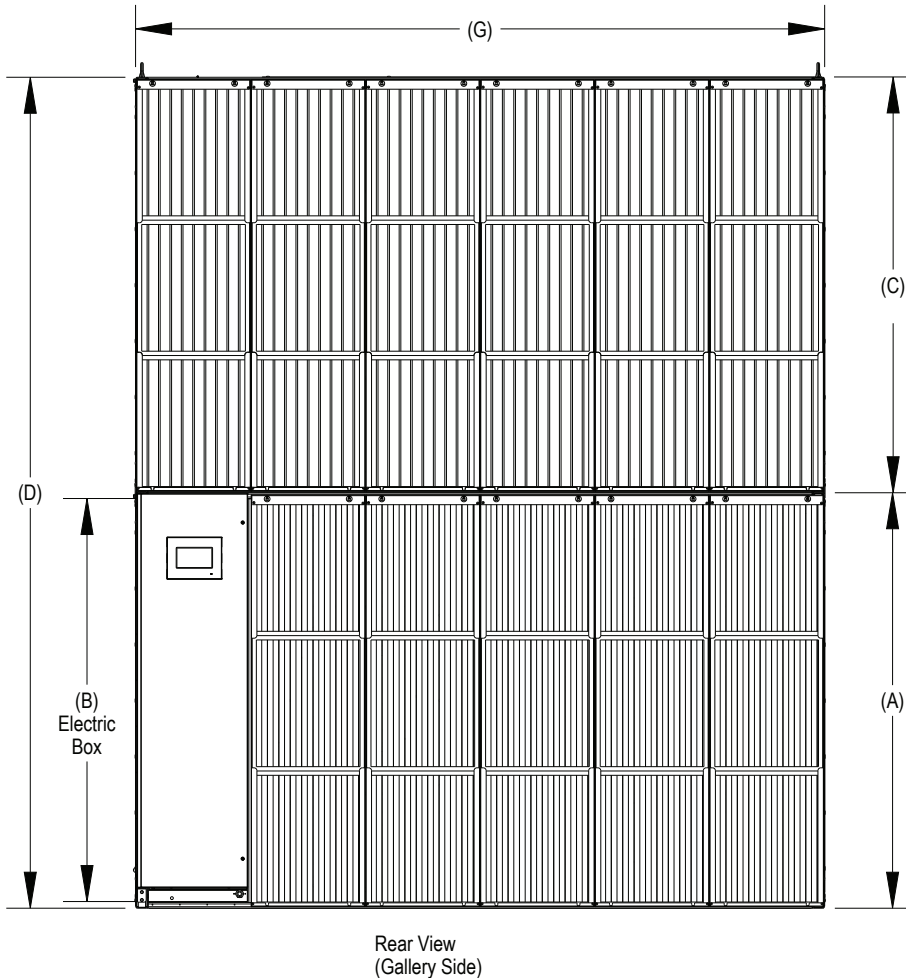
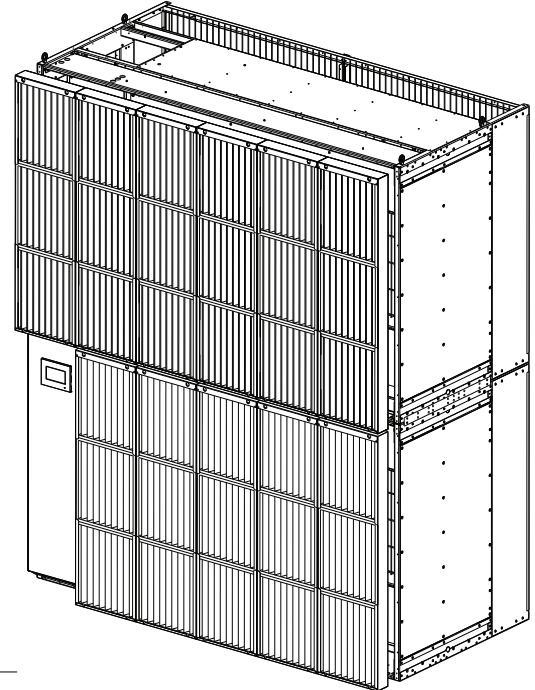
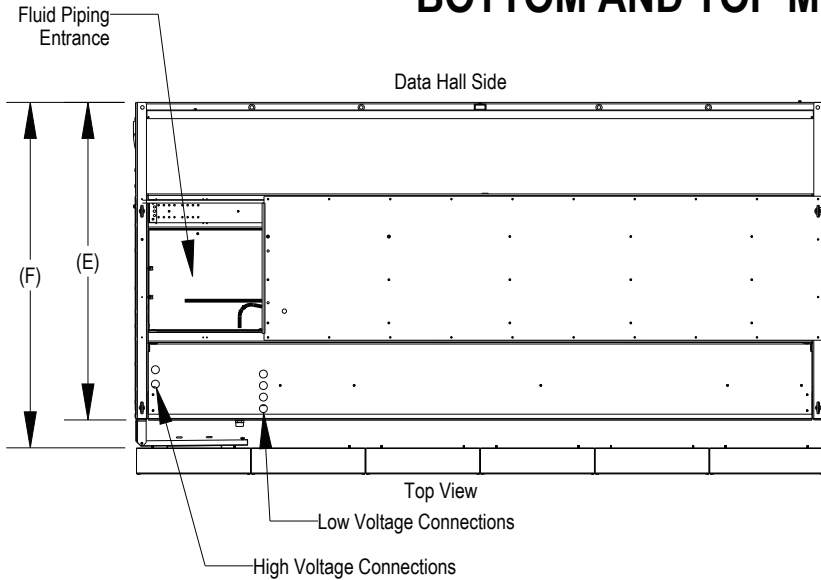

Chilled Water Model Number		CA60
Dimensional Data mm. [inch]	A	1832 [72.13]
	B	1778 [69.99]
	C	1834 [72.19]
	D	3664 [144.26]
	E	1400 [55.13]
	F	1524 [60.00]
	G	3039 [119.63]

- Notes:
1. Filters are accessible on the Gallery Side.
 2. See Sheet 2 for Anchoring Dimensions.

CoolLoop Thermal Wall

CA60 CABINET & ANCHOR DIMENSIONAL DATA

BOTTOM MODULE

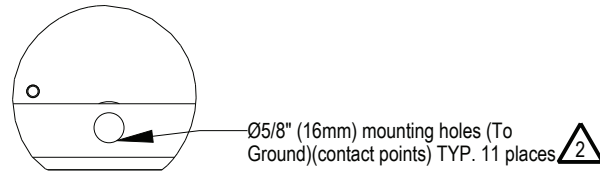

Detail A

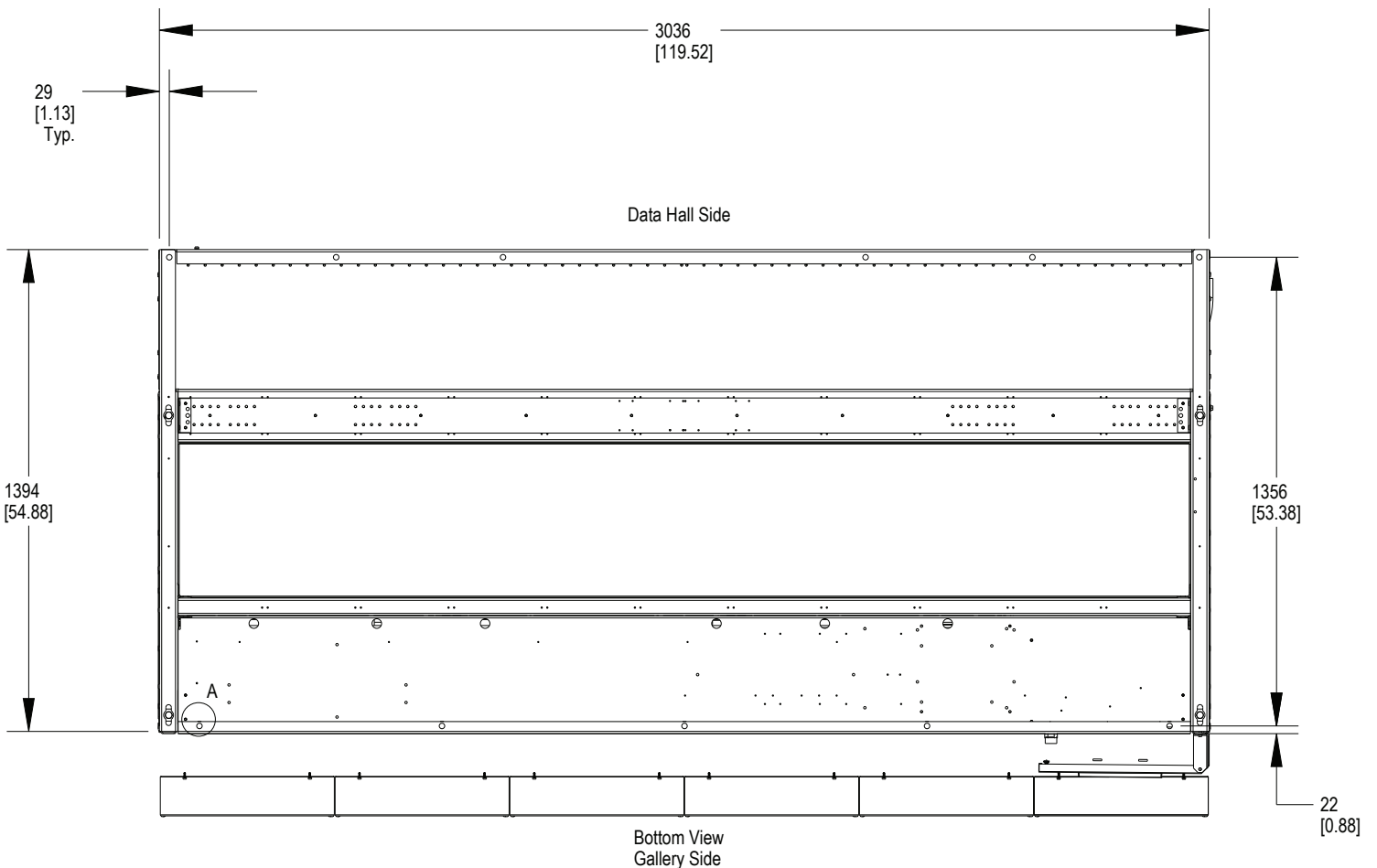

Notes:

1. Underside of unit. All components not part of the bottom frame removed for clarity.

 Eleven (11) Floor mounting holes and (11) 1/2" field supplied bolts required to secure unit base to customer support structure. Bolt grade to be specified by local requirements.



CoolLoop Thermal Wall

CA60 CABINET & ANCHOR DIMENSIONAL DATA WEIGHTS

Unit Weights

	Module Dry Weight kg (lbs.)	Operating Weight kg (lbs.)	Module Domestic Pack kg (lbs.)	Module Export Pack kg (lbs.)
Top Module (with Coil and Fans)	1242 (2738)	1378 (3038)	1412 (3113)	1436 (3168)
Bottom Module (with Coil, Fans and Electrical Box)	1417 (3123)	1552 (3423)	1587 (3498)	1612 (3553)

Packaging Dimensions (All Units)

	Domestic Pack Dimensions L x W x H mm (inch)	Export Pack Dimensions L x W x H mm (inch)
Top Module	3352 x 1778 x 2159 (132 x 70 x 85)	3352 x 1778 x 1981 (132 x 70 x 78)
Bottom Module	3352 x 1778 x 2235 (132 x 70 x 88)	3352 x 1778 x 2261 (132 x 70 x 89)

Notes:

 Weights reflect heaviest configuration

CA60 INSTALLATION AND SERVICE CLEARANCE

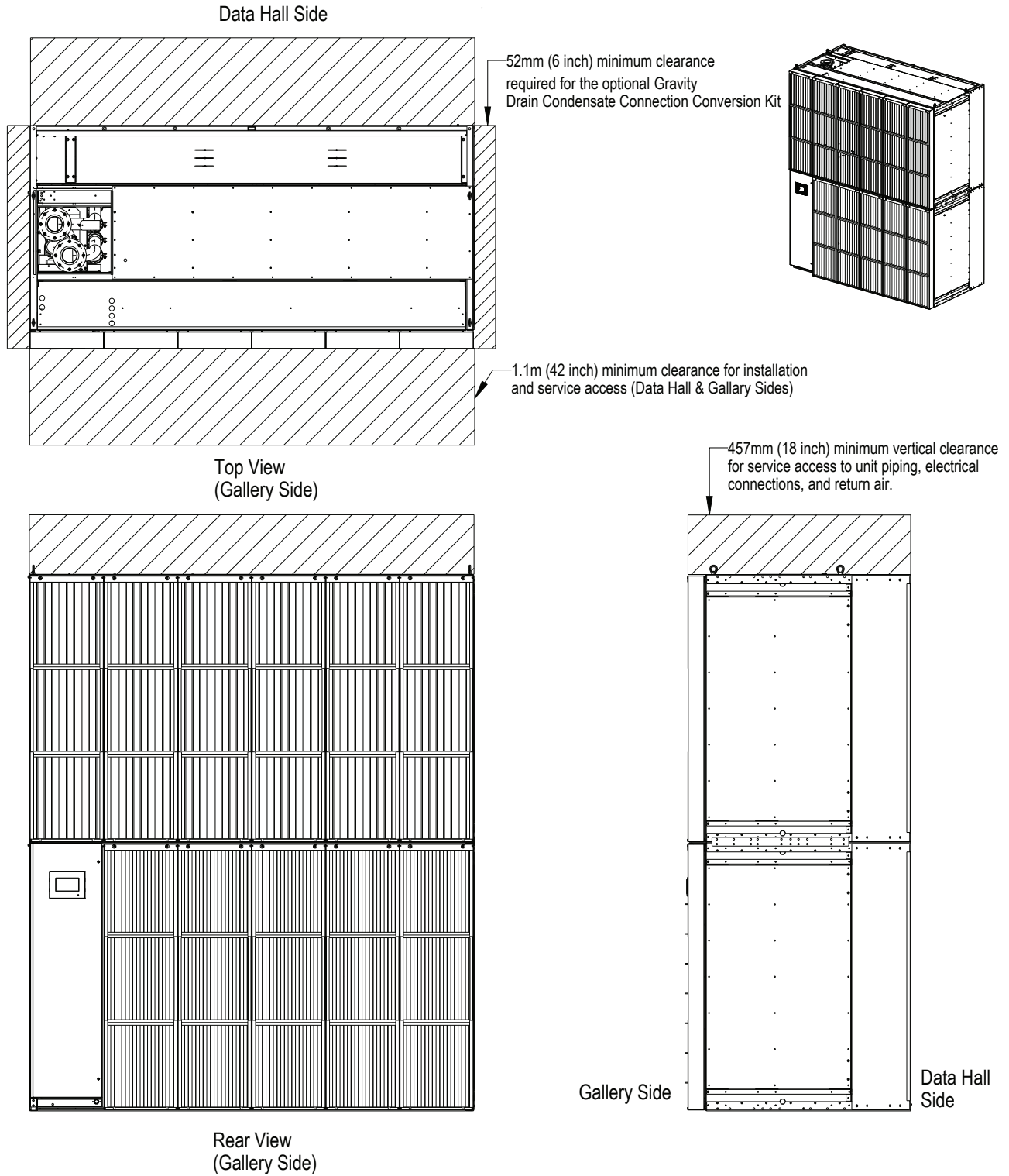



CoolLoop Thermal Wall

CA60 FLOOR PLANNING FOR ADJACENT UNITS

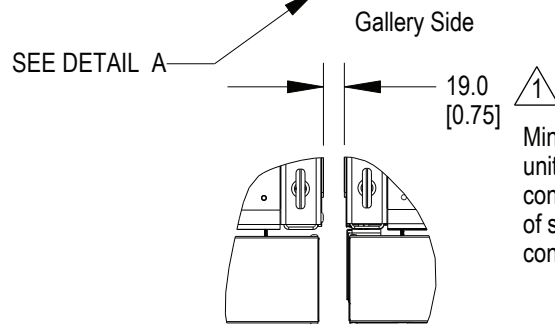
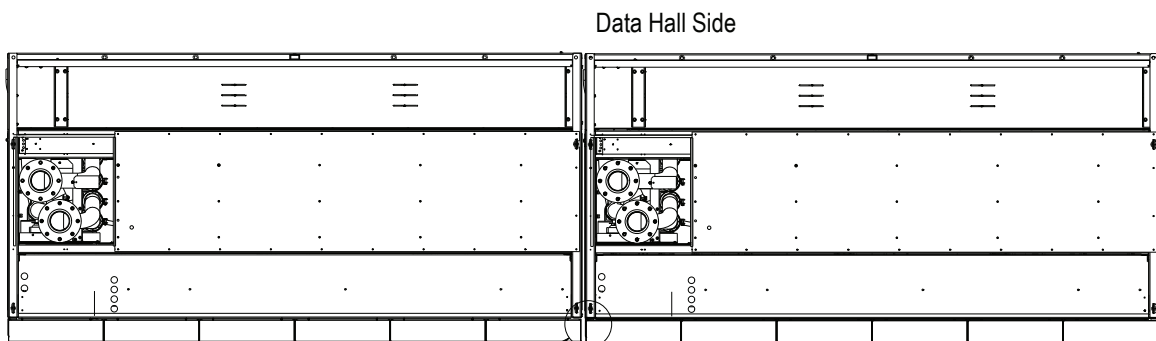
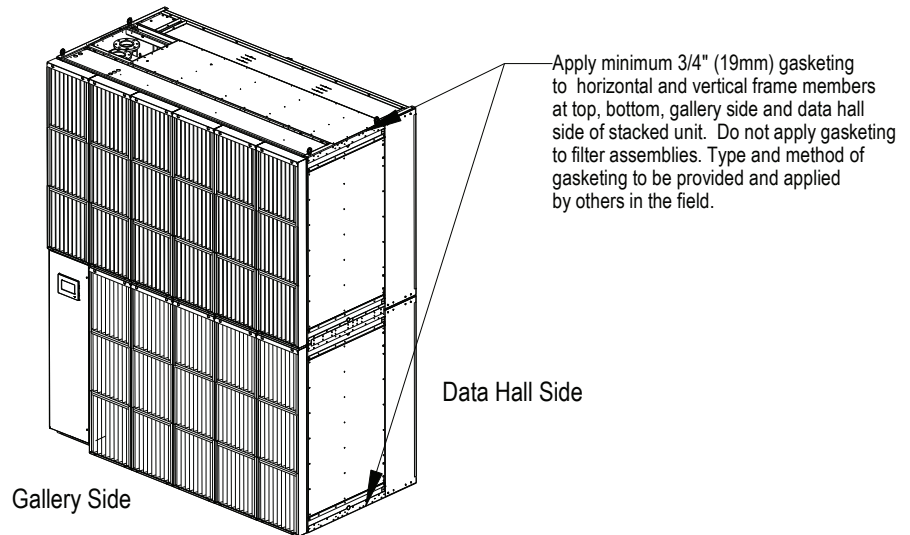

Minimum Gap to be filled with gasketing between units that do not have the gravity condensate connection conversion kit. Apply 152 mm (6 in) of side clearance when a gravity condensate connection conversion kit is installed.

Detail A

Notes:

$\triangle 1$. Gap is measured between frame members of adjacent units.

CoolLoop Thermal Wall

CA60 AIRFLOW SCHEMATIC

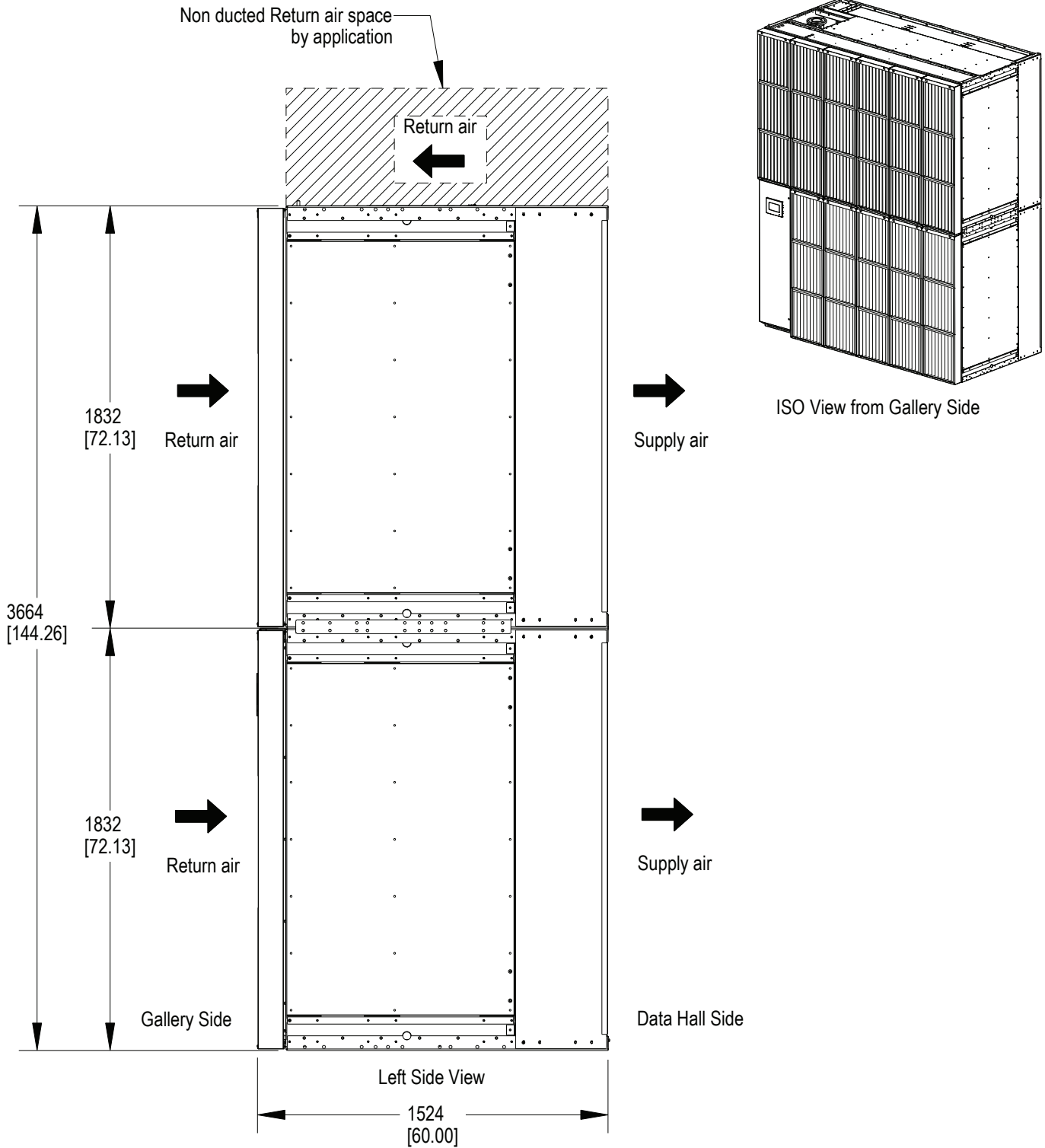



CoolLoop Thermal Wall

CA60 GENERAL ARRANGEMENT DIAGRAM

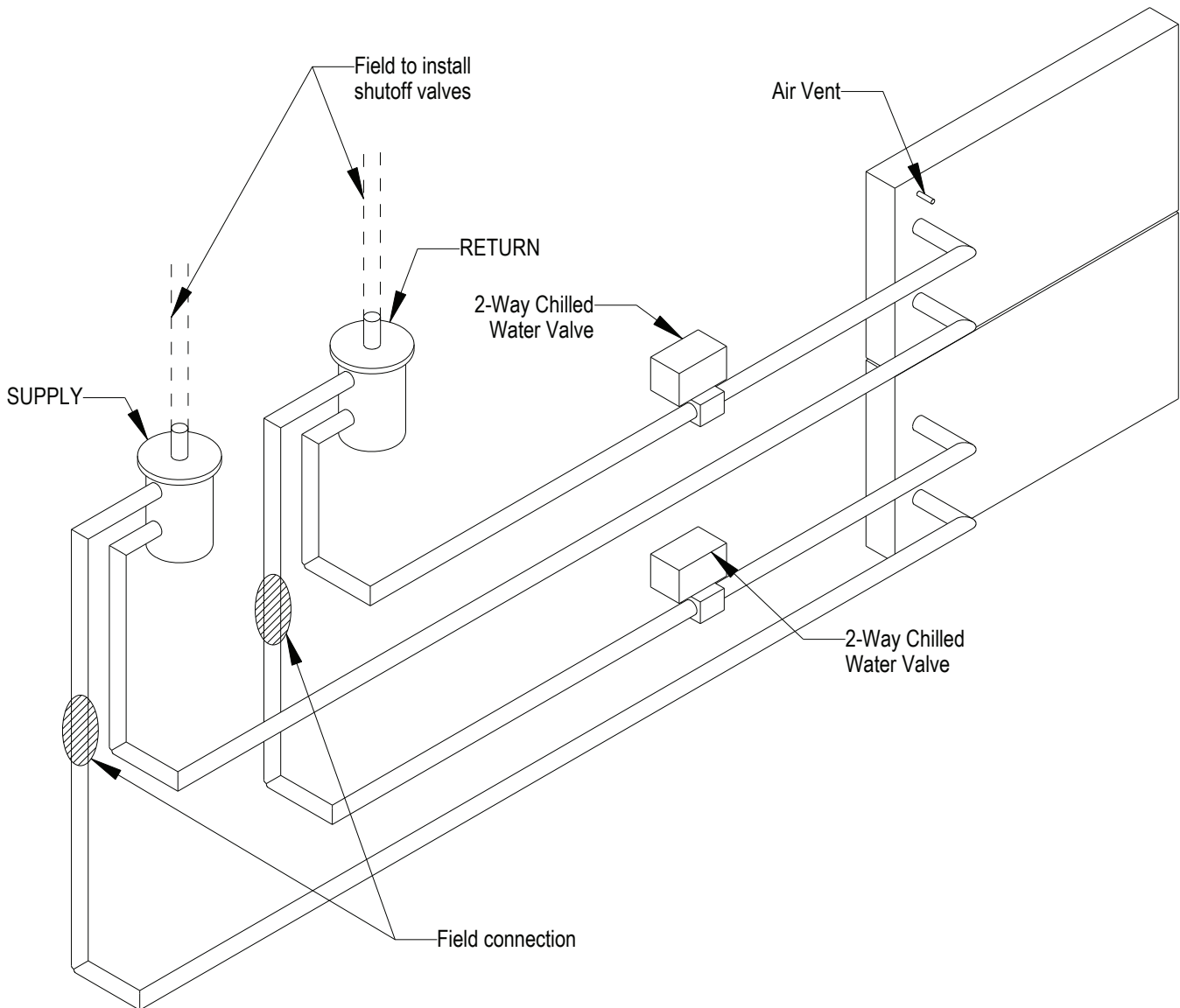

Note:

1) Components are not supplied by Vertiv, but are required for proper circuit operation and maintenance

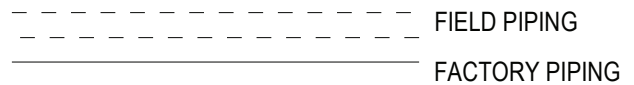



CoolLoop Thermal Wall

CA60 SEISMIC APPLICATION ASSUMPTIONS AND REQUIREMENTS

Vertiv has conducted analytical modeling of the Vertiv™ CoolLoop Thermal Wall product to provide an option for those systems requiring seismic certification of compliance. This certification goes beyond the equipment's ability to withstand the seismic forces: the IBC (International Building Code) and ASCE (American Society of Civil Engineers) system approach includes the equipment, equipment anchorage, and the connections to the equipment [power, piping, and ducting].

Certification Criteria

The Vertiv™ CoolLoop Thermal Wall certification is based on a maximum mapped, maximum considered earthquake spectral response acceleration value, S_s , of 1.125g adjusted by the soil site coefficient to Soil Site Class D as the default when the site soil properties or final equipment installation location is not known. The certification maximum spectral response coefficient is S_{ds} value of .75g including Soil Class and Seismic Use group corrections. Soil Classes A, B, C, D, and E, and Seismic Design Categories A, B, C, D, E, and F are all covered under this certification, limited by the S_{ds} value stated above. Structural analysis has been conducted to demonstrate that the equipment meets performance objectives required for a component importance factor (I_p) of 1.0. Specifically, structural integrity is demonstrated such as to not pose a life safety hazard. A Vertiv™ CoolLoop Thermal Wall, as described above, is approved for seismic application as a system when properly installed in the following configurations:

- Vertiv™ CoolLoop Thermal Wall unit, with factory-installed seismic option, attached directly to a housekeeping pad using the anchoring system defined in this document.
- The certification excludes all non-Vertiv supplied accessories, including but not limited to floor stands, and isolators.

Certification	IBC	
Internal Bracing Option	Factory installed	
Unit	S_{ds}	I_p
CA060 (Top and Bottom Module)	.75	1.0



CoolLoop Thermal Wall

CA60 SEISMIC APPLICATION ASSUMPTIONS AND REQUIREMENTS

Requirements for Anchorage

Anchors

1. Mounting requirement details such as brand, type, embedment depth, edge spacing, anchor spacing, concrete strength, wall bracing, and special inspection must be outlined and approved by the project Structural Engineer of Record.

Anchorage Surface

2. Structural floors and housekeeping pads must also be seismically designed and approved by the project Structural Engineer of Record to withstand the seismic anchor loads as defined on the installation drawings. The installing contractor is responsible for the proper installation of all anchors and mounting hardware, observing the mounting requirement details outlined by the Engineer of Record. Contact the Manufacturer's Representative if a detailed Seismic Installation Calculation Package is required.

Unit Field Connections

3. Piping Field Connections: All units, either rigidly mounted or mounted on vibration isolators, shall be attached to the piping system using flexible loops designed for seismic movement. Flexible loops shall be capable of movement in the three axes and must completely isolate the equipment from the piping. The loops shall be suitable for an operating pressure and temperature of the system, refer to Vertiv installation instructions. This includes condensate drainage, and chilled water supply and return. Follow manufacturer's installation instructions for proper seismic application of flexible looping.

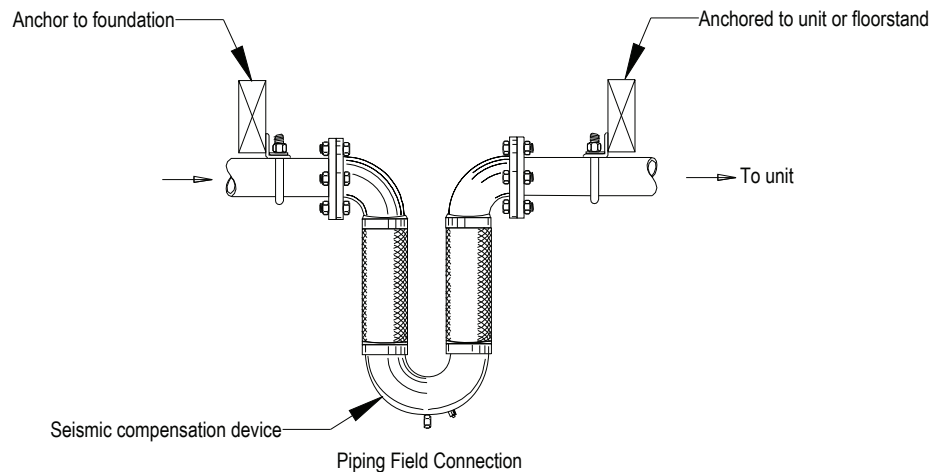

4. Electrical Connections: Must have adequate flexibility for seismic movement. Electrical wiring, conduit, and/or other connections to the equipment is the responsibility of others. Data and recommendations are supplied here and in the unit installation supplement for seismic installation.

CoolLoop Thermal Wall

CA60 DIMENSIONAL DATA SEISMIC MOUNTING (W/O ANCHOR BRACKETS)

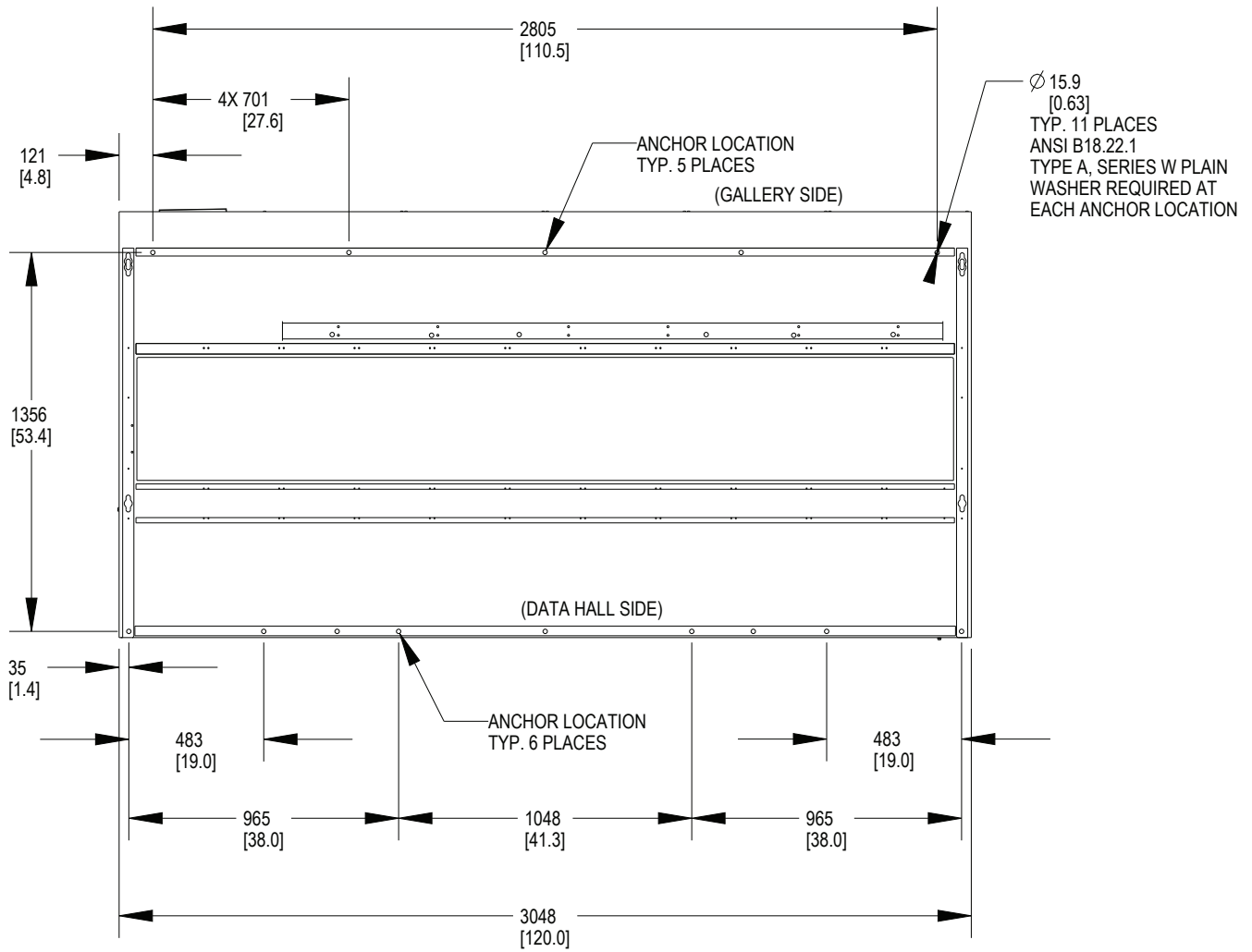

FLOOR ANCHORING DIMENSIONS (BOTTOM VIEW OF THE UNIT)

Notes:

1. Anchor Bolt sized per Engineer of Record.
2. Specified by Engineer of Record.



CoolLoop Thermal Wall

CA60 SEISMIC APPLICATION ASSUMPTIONS AND REQUIREMENTS

Vertiv has conducted analytical modeling of the Vertiv™ CoolLoop Thermal Wall product to provide an option for those systems requiring seismic certification of compliance. This certification goes beyond the equipment's ability to withstand the seismic forces: the IBC (International Building Code) and ASCE (American Society of Civil Engineers) system approach includes the equipment, equipment anchorage, and the connections to the equipment [power, piping, and ducting].

Certification Criteria

The Vertiv™ CoolLoop Thermal Wall certification is based on a maximum mapped, maximum considered earthquake spectral response acceleration value, S_s , of 1.125g adjusted by the soil site coefficient to Soil Site Class D as the default when the site soil properties or final equipment installation location is not known. The certification maximum spectral response coefficient is S_{ds} value of 2.5g including Soil Class and Seismic Use group corrections. Soil Classes A, B, C, D, and E, and Seismic Design Categories A, B, C, D, E, and F are all covered under this certification, limited by the S_{ds} value stated above. Structural analysis has been conducted to demonstrate that the equipment meets performance objectives required for a component importance factor (I_p) of 1.0. Specifically, structural integrity is demonstrated such as to not pose a life safety hazard. A Vertiv™ CoolLoop Thermal Wall, as described above, is approved for seismic application as a system when properly installed in the following configurations:

- Vertiv™ CoolLoop Thermal Wall unit, with factory-installed seismic option, attached directly to a housekeeping pad using the anchoring system defined in this document.
- The certification excludes all non-Vertiv supplied accessories, including but not limited to floor stands, and isolators.

Certification	IBC	
Internal Bracing Option	Factory installed	
Unit	S_{ds}	I_p
CA060 (Top and Bottom Module)	2.5	1.0



CoolLoop Thermal Wall

CA60 SEISMIC APPLICATION ASSUMPTIONS AND REQUIREMENTS

Requirements for Anchorage

Anchors

1. Mounting requirement details such as brand, type, embedment depth, edge spacing, anchor spacing, concrete strength, wall bracing, and special inspection must be outlined and approved by the project Structural Engineer of Record.

Anchorage Surface

2. Structural floors and housekeeping pads must also be seismically designed and approved by the project Structural Engineer of Record to withstand the seismic anchor loads as defined on the installation drawings. The installing contractor is responsible for the proper installation of all anchors and mounting hardware, observing the mounting requirement details outlined by the Engineer of Record. Contact the Manufacturer's Representative if a detailed Seismic Installation Calculation Package is required.

Unit Field Connections

3. Piping Field Connections: All units, either rigidly mounted or mounted on vibration isolators, shall be attached to the piping system using flexible loops designed for seismic movement. Flexible loops shall be capable of movement in the three axes and must completely isolate the equipment from the piping. The loops shall be suitable for an operating pressure and temperature of the system, refer to Vertiv installation instructions. This includes condensate drainage, and chilled water supply and return. Follow manufacturer's installation instructions for proper seismic application of flexible looping.

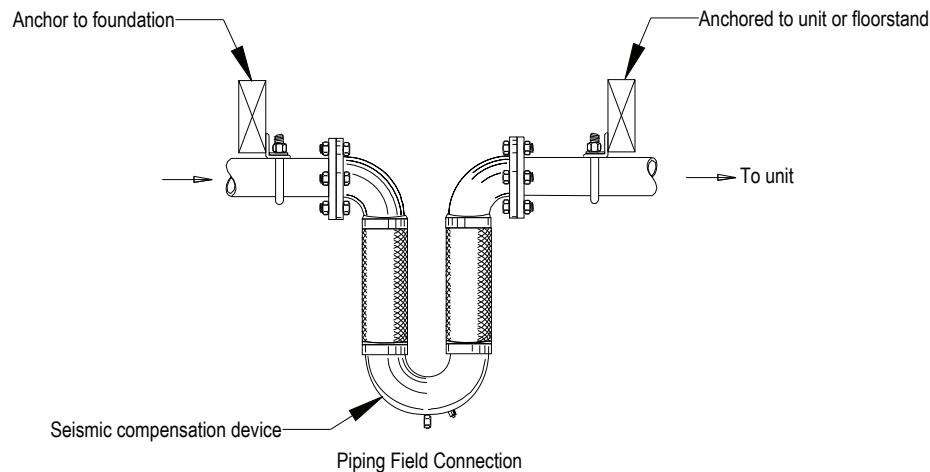

4. Electrical Connections: Must have adequate flexibility for seismic movement. Electrical wiring, conduit, and/or other connections to the equipment is the responsibility of others. Data and recommendations are supplied here and in the unit installation supplement for seismic installation.

CoolLoop Thermal Wall

CA 60 DIMENSIONAL DATA SEISMIC 2.5 Sds MOUNTING

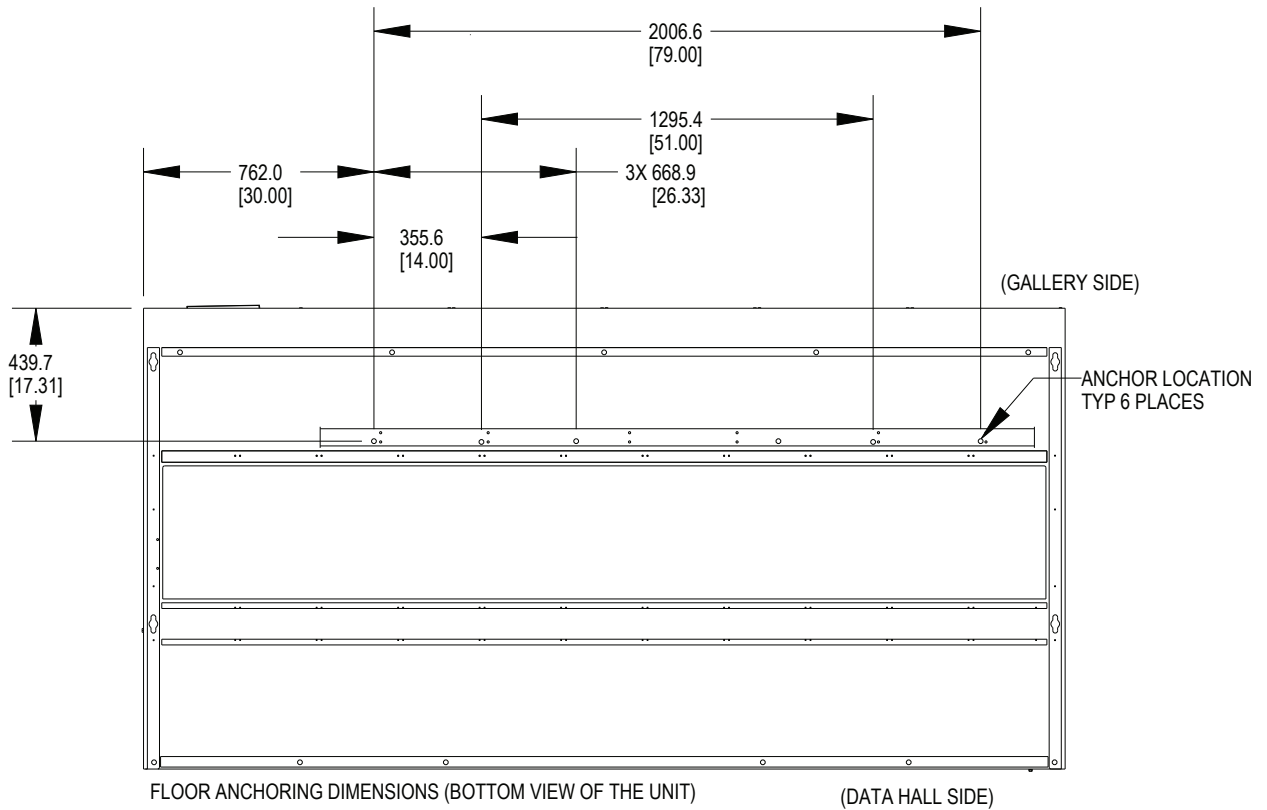

- Notes:
1. Anchor Bolt sized per Engineer of Record.
 2. Specified by Engineer of Record.
 3. Refer to 20000786 for mounting of 2.5 Sds units during installation. Plan for prior to anchoring.

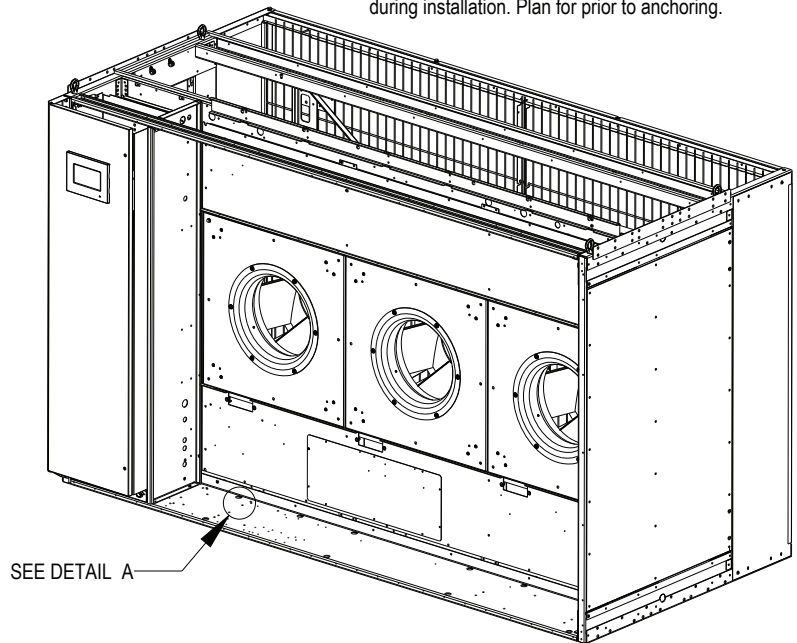
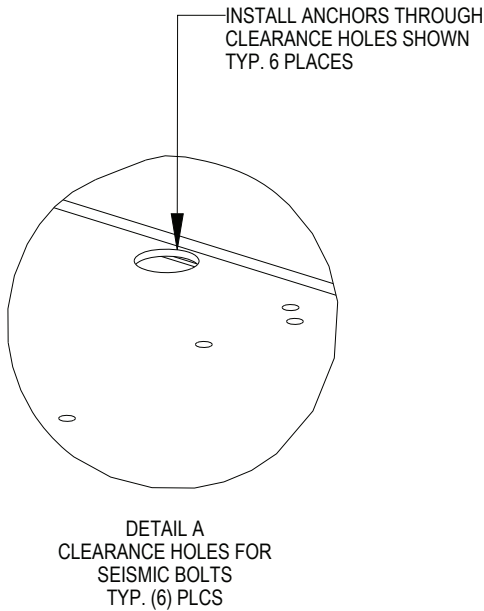

CA60 FILTER AND FILTER RACK REMOVAL

FILTERS ARE REMOVED FROM CENTER POSITION OF THE FILTER RACK.
LIFT THE FILTER UP AND OUT TO REMOVE FROM RACK.

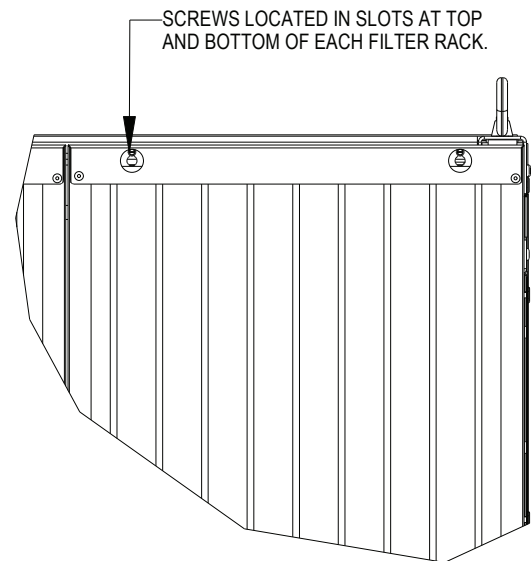
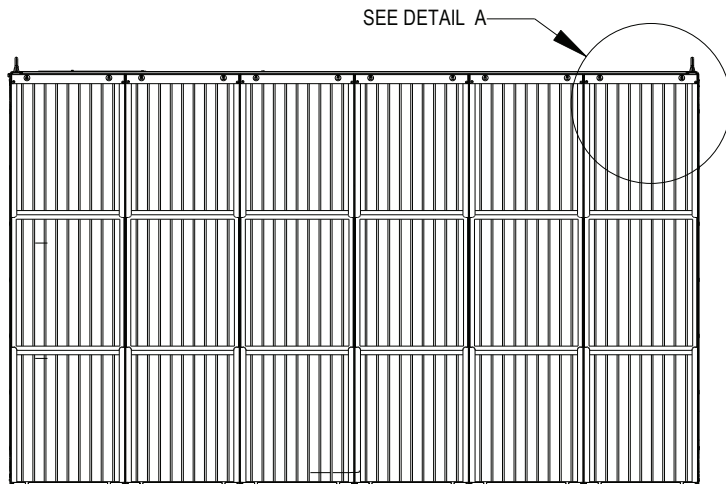
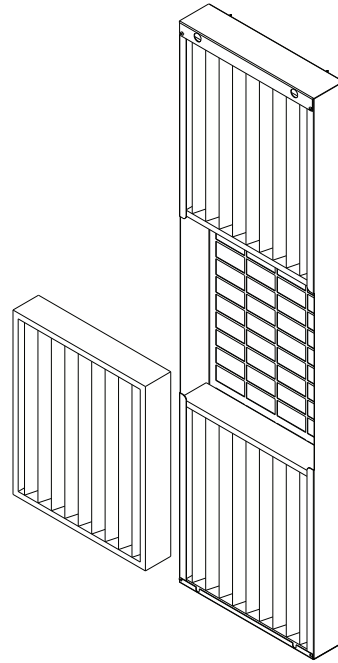
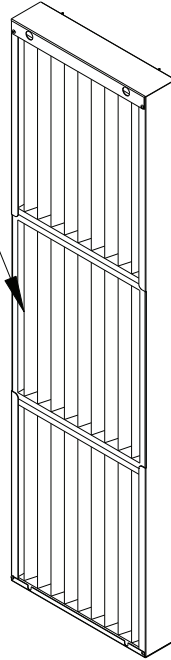

FILTER RACK REMOVAL INSTRUCTIONS

1. REMOVE FILTERS FROM RACK.
2. LOOSEN (2) SCREWS AT THE TOP AND BOTTOM OF FILTER RACK.
3. LIFT FILTER RACK UP AND OUT TO REMOVE THE RACK.

CoolLoop Thermal Wall

TOP AND BOTTOM MODULE ASSEMBLY

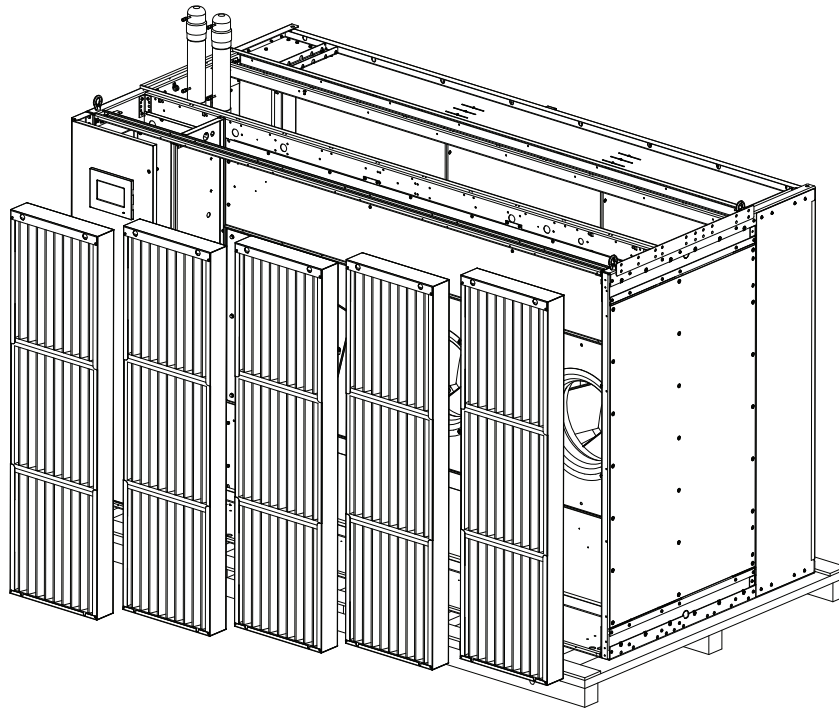
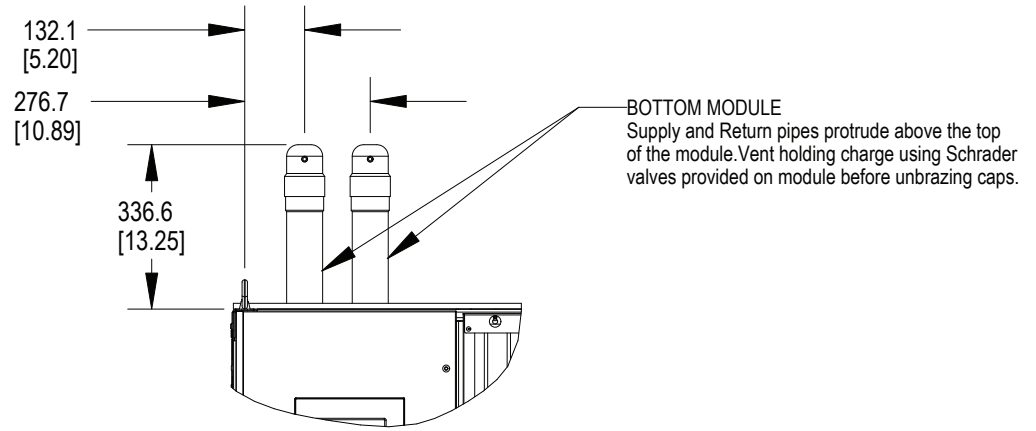

GALLERY SIDE
BOTTOM MODULE

Notes:

1. Remove exterior packaging material from module.
2. Unit ships in two sections, Top module and Bottom module.
3. Each module is fastened to the shipping skid with Lag screws through the provided mounting holes.
4. Remove filter rack assemblies from each module. (See 20000785 for details on filter rack removal)
5. Dimensions are in mm [in.].

Refer to Vertiv™ CoolLoop Thermal Wall user manual for detailed installation instructions

CoolLoop Thermal Wall

TOP AND BOTTOM MODULE ASSEMBLY

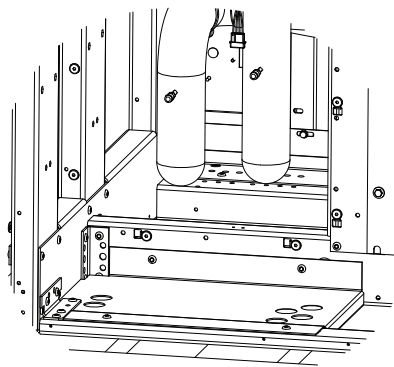
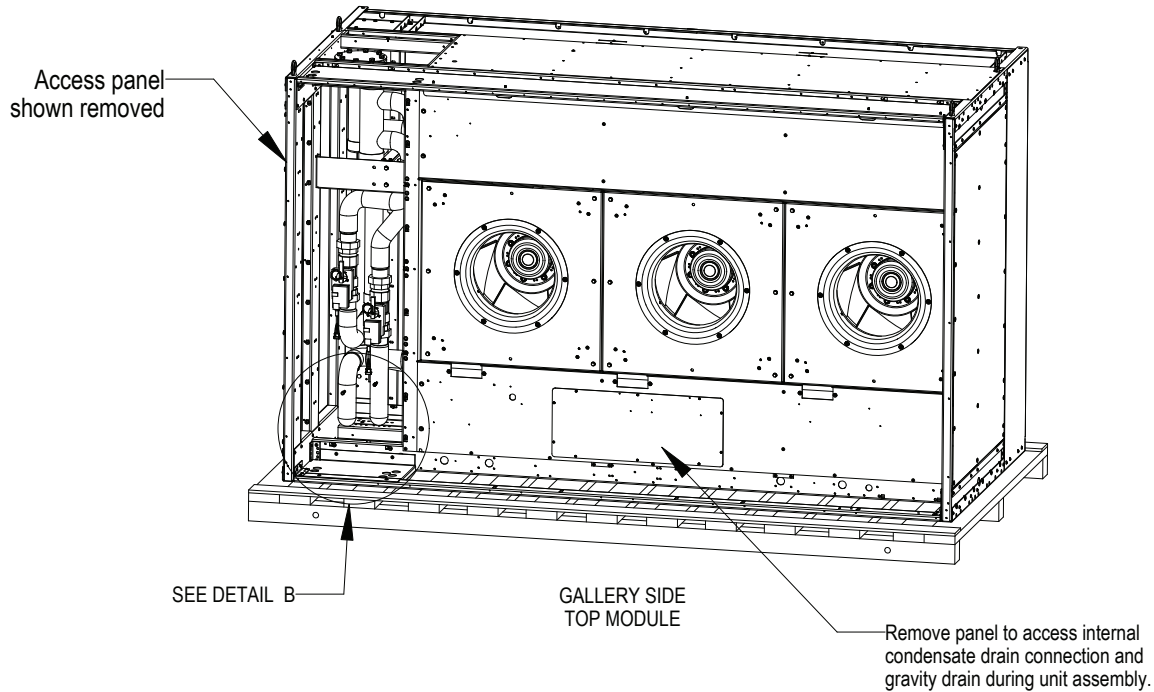

DETAIL B
SPUN CLOSED

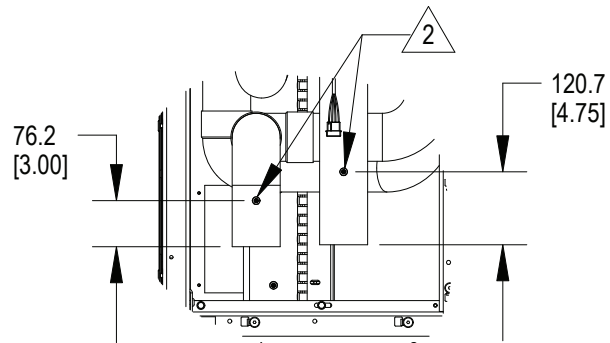

DIMENSIONS REQUIRED FOR
CONNECTION TO BOTTOM MODULE

Notes:

1. On Top Module, remove Panel to access the internal piping for the supply and return connections.
2. Vent holding charge using Schrader valves provided on module before removing any fittings. Schrader valves on connections are intended solely for venting the unit.
3. Prepare internal piping connections by cutting to dimensions specified in above details. Remove any excess piping material using a tube cutter or other non burring device. Clean up shavings and other materials before making supply and return piping connections.
4. If the optional Vertiv™ Gravity Drain Condensate Connection Conversion Kit has been purchased, reference the factory provided document (20000801) for installation steps.

Refer to Vertiv™ CoolLoop Thermal Walluser manual for detailed installation instructions



CoolLoop Thermal Wall

TOP AND BOTTOM MODULE ASSEMBLY

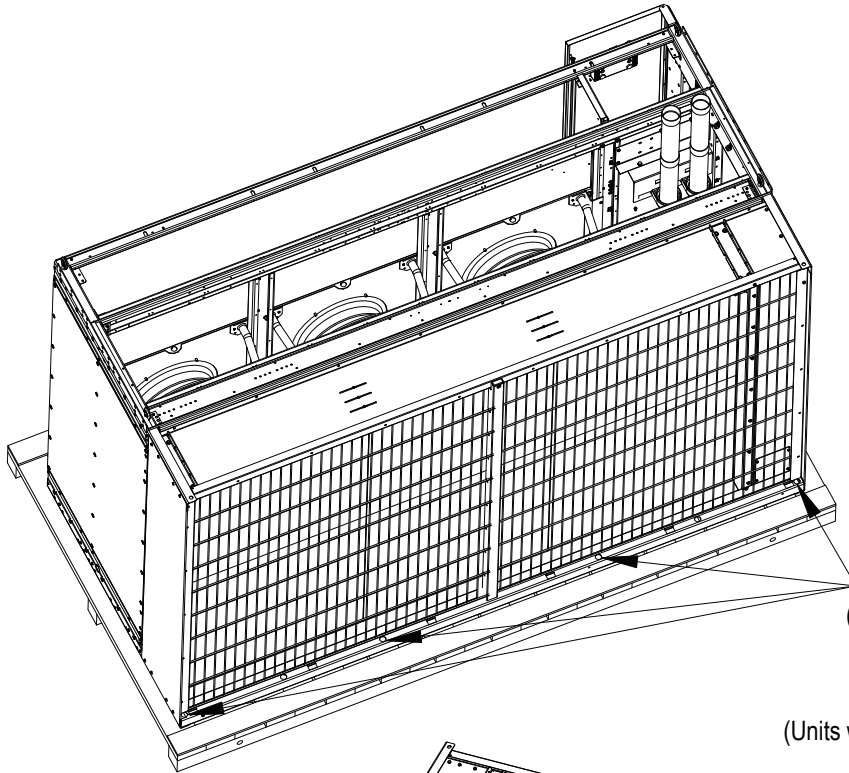

Lag screw location
(Typ. Top and Bottom Module)

Remove cover to access
lag screw location.
(Units with Vertiv™ Liqui-tec™ option only)

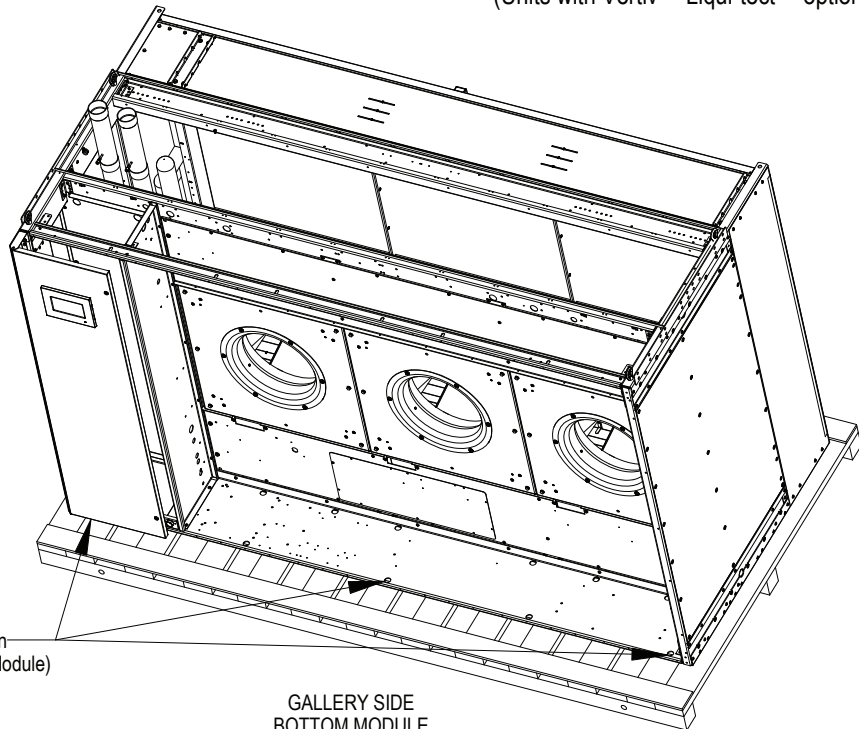

Lag screw location
(Typ. Top and Bottom Module)

GALLERY SIDE
BOTTOM MODULE

Notes:

1. Unbolt Lag screws from skid on Top and Bottom Module.
2. For 2.5 Sds seismic rated units, field must reinstall rear bracing per page 6.

Refer to Vertiv™ CoolLoop Thermal Wall user manual for detailed installation instructions

CoolLoop Thermal Wall

TOP AND BOTTOM MODULE ASSEMBLY

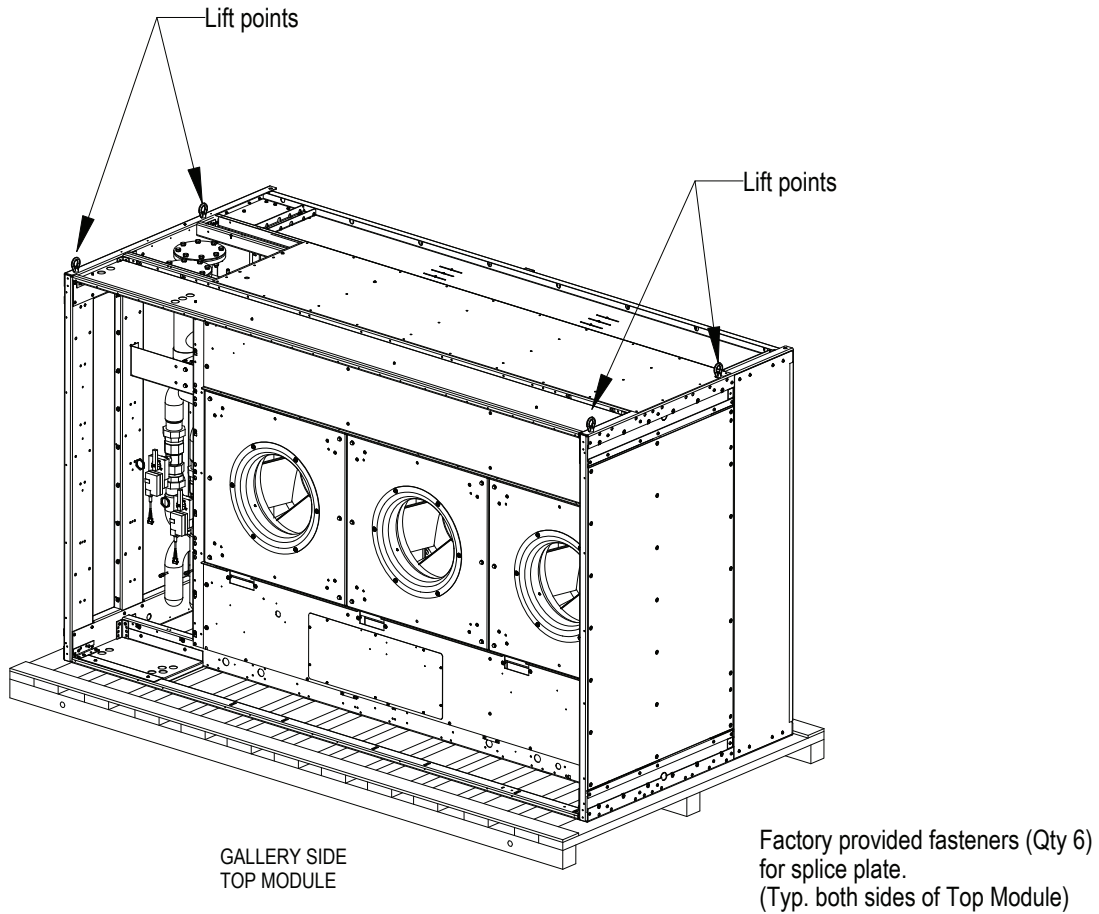

Notes:

1. Lifting force must be completely vertical at each lift point location.

Refer to Vertiv™ CoolLoop Thermal Wall user manual for detailed installation instructions



VERTIV™

CoolLoop Thermal Wall

TOP AND BOTTOM MODULE ASSEMBLY

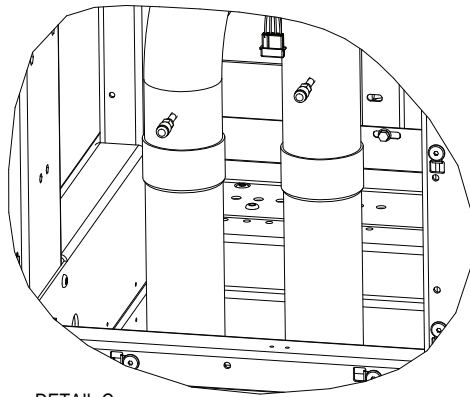

DETAIL C

SPLICE PLATE

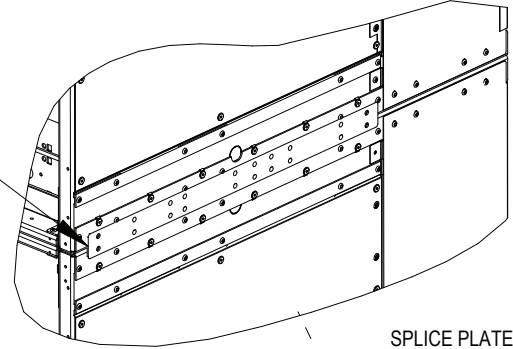

SPLICE PLATE DETAIL

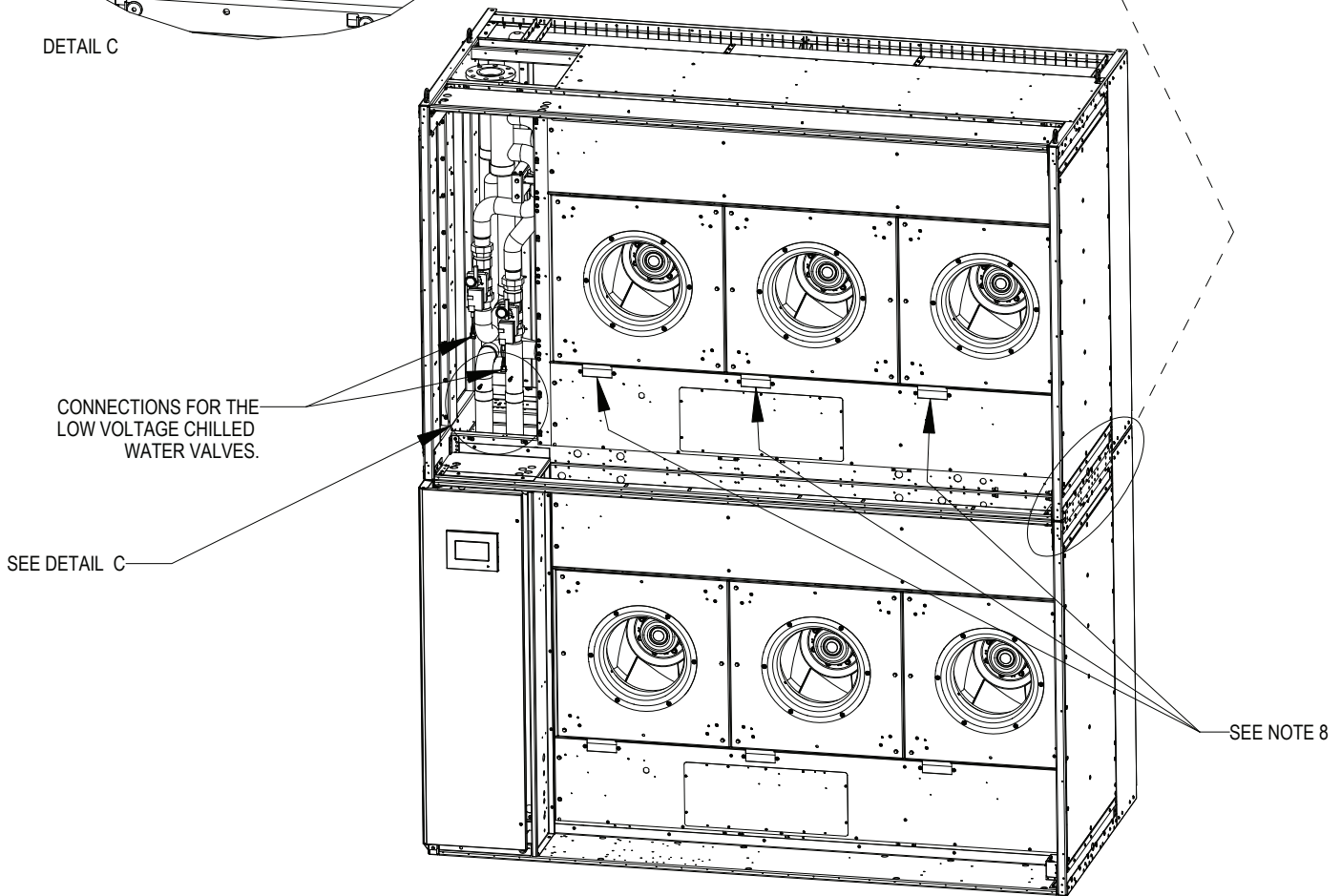

Notes:

1. Field must use a professional rigger to lift and assemble the top and bottom module.
2. Modules must be fastened together with factory provided splice plate and fasteners. (Typ. both sides)
3. Braze internal piping connections.
4. Assemble internal Condensate connection between Top and Bottom Module. (See 20000788 for details)
5. Leak check assembled unit.
6. Field must use a professional rigger to move the assembled unit into place. (See 20000779 for Bottom Module Mounting. For 2.5 Sds seismic rated units, field must reinstall rear bracing per page 6.
7. Complete electrical connection for the low voltage Chilled Water valves and then reattach panel covers on Top Module piping section and Top and Bottom Module lifting points.
8. Complete electrical connections for Top Module fans then reinstall filter racks on Top and Bottom Module.
9. See User Manual to complete unit installation.

Refer to Vertiv™ CoolLoop Thermal Wall user manual for detailed installation instructions

CoolLoop Thermal Wall

TOP AND BOTTOM MODULE ASSEMBLY EXTERNAL BRACING FOR SEISMIC UNITS

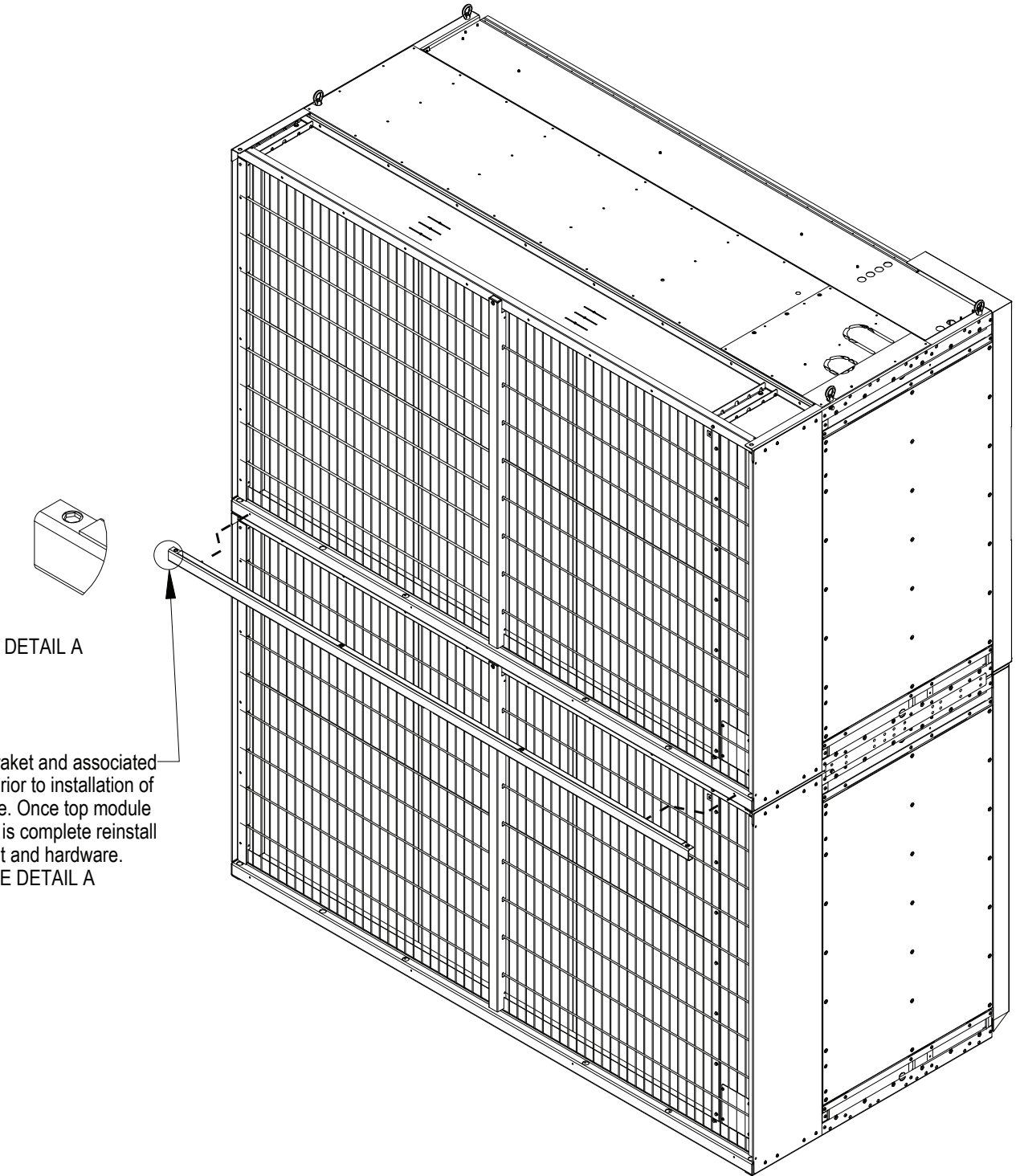

DETAIL A

Remove bracket and associated hardware prior to installation of top module. Once top module installation is complete reinstall bracket and hardware. SEE DETAIL A



CoolLoop Thermal Wall

CA60 ELECTRICAL FIELD CONNECTIONS

STANDARD ELECTRICAL CONNECTIONS

1. High voltage entrance - Located in the top of the box (quantity 2).
2. Low voltage entrance - Located in the top of the box (quantity 1-4).
3. Three phase electrical service - Terminals are on top of disconnect switch. Three phase service not provided by Vertiv.
4. Earth ground - Terminal for field supplied earth grounding wire and component ground terminal strip. Earth grounding required for Vertiv™ units.
5. Unit factory installed disconnect switch and Main Fuses - Access to the high voltage electric panel compartment can be obtained only with the switch in the "off" position. Fused disconnects are provided with a defeater button that allows access to the electrical panel when power is on.
6. Remote unit shutdown - Replace existing jumper between terminals 37 & 38 with field supplied normally closed switch having a minimum 75VA, 24VAC rating. Use field supplied Class 1 wiring.
7. Customer alarm inputs - Terminals for field supplied, normally open contacts, having a minimum 75VA, 24VAC rating, between terminals 24 & 50, 51, 55, 56. Use field supplied Class 1 wiring. Terminal availability varies by unit options.
8. Common alarm - On any alarm, normally open dry contact is closed across terminals 75 & 76 for remote indication 1 AMP, 24VAC max load. Use Class 1 field supplied wiring.
9. Unit-to-Unit - Plug 64 is reserved for U2U communication
10. Site and BMS - Plug 74 and terminal block 3 are reserved for Site and BMS connections. Plug 74 is an eight pin RJ45 for a Cat 5 cable. Terminal block 3 is a two-position screw terminal block for use with twisted pair wires.

OPTIONAL LOW VOLTAGE TERMINAL PACKAGE CONNECTIONS

11. Remote unit shutdown - Two additional contact pairs available for unit shutdown (labeled as 37B & 38B, 37C & 38C). Replace jumpers with field supplied normally closed switch having a minimum 75VA, 24VAC rating. Use field supplied Class 1 wiring.
12. Extra Common alarm - On any alarm, two additional normally open dry contacts are closed across terminals 94 & 95 and 96 & 97 for remote indication. 1 AMP, 24VAC max load. Use Class 1 field supplied wiring.
13. Main fan enabled contact - On enable, normally open dry contact is closed across terminals 84 & 85 for remote indication. 1 AMP, 24VAC max load. Use Class 1 field supplied wiring.
14. Vertiv™ Liqui-Tect™ shutdown and dry contact - On Liqui-Tect activation, normally open dry contact is closed across terminals 58 & 59 for remote indication (Liqui-Tect sensor ordered separately). 1 AMP, 24VAC max load. Use Class 1 field supplied wiring.

OPTIONAL ELECTRICAL CONNECTIONS

15. Smoke sensor alarm - Factory wired dry contacts from smoke sensor are 91-common, 92-NO, and 93-NC. Supervised contacts, 80 & 81, open on sensor trouble indication. This smoke sensor is not intended to function as, or replace, any room smoke detection system that may be required by local or national codes. 1 AMP, 24VAC max load. Use Class 1 field supplied wiring.
16. Analog inputs- Terminals 41, 42, 43, and 44 are user configurable for 0-10V, 0-5V, or 4-20MA.
17. Condensate alarm (with condensate pump option) - On pump high water indication, normally open dry contact is closed across terminals 88 & 89 for remote indication. 1 AMP, 24VAC max load. Use Class 1 field supplied wiring.
18. Remote humidifier - On any call for humidification, normally open dry contact is closed across terminals 11 and 12 to signal field supplied remote humidifier. 1 AMP, 24VAC max load. Use Class 1 field supplied wiring

CA60 ELECTRICAL FIELD CONNECTIONS (SHOWN WITH DUAL POWER)

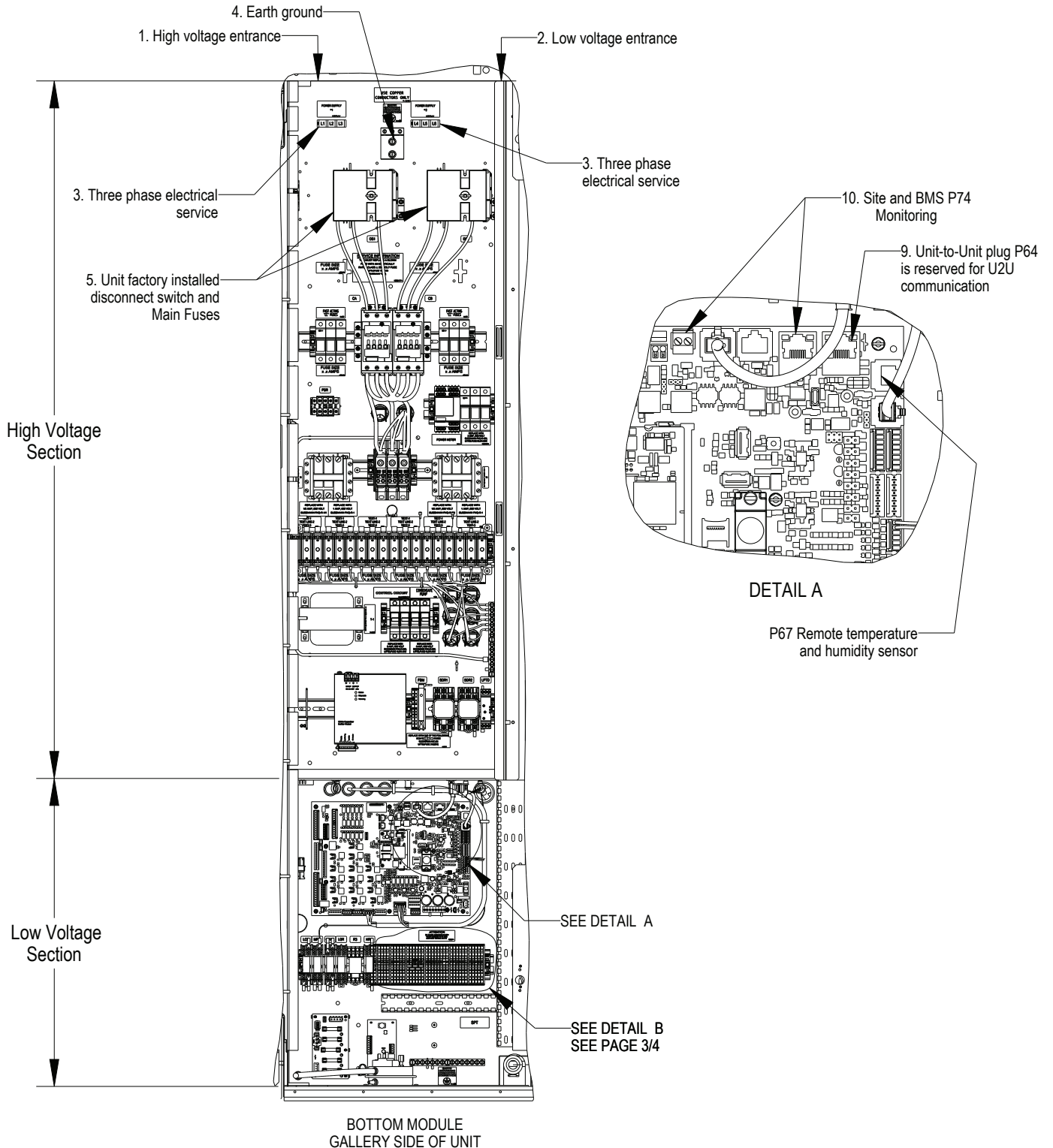

CA60 ELECTRICAL FIELD CONNECTIONS

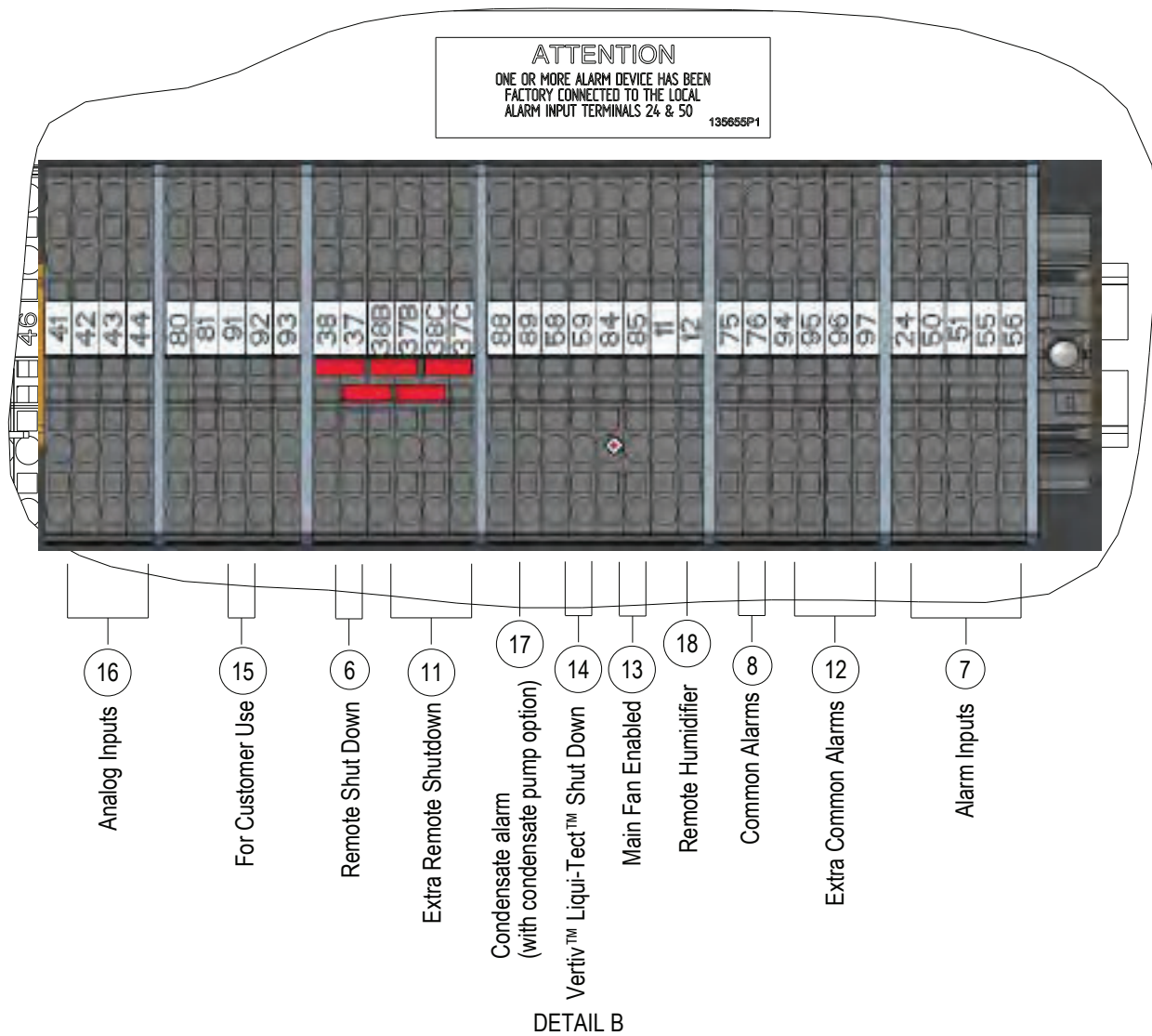

CA60 ELECTRICAL FIELD CONNECTIONS

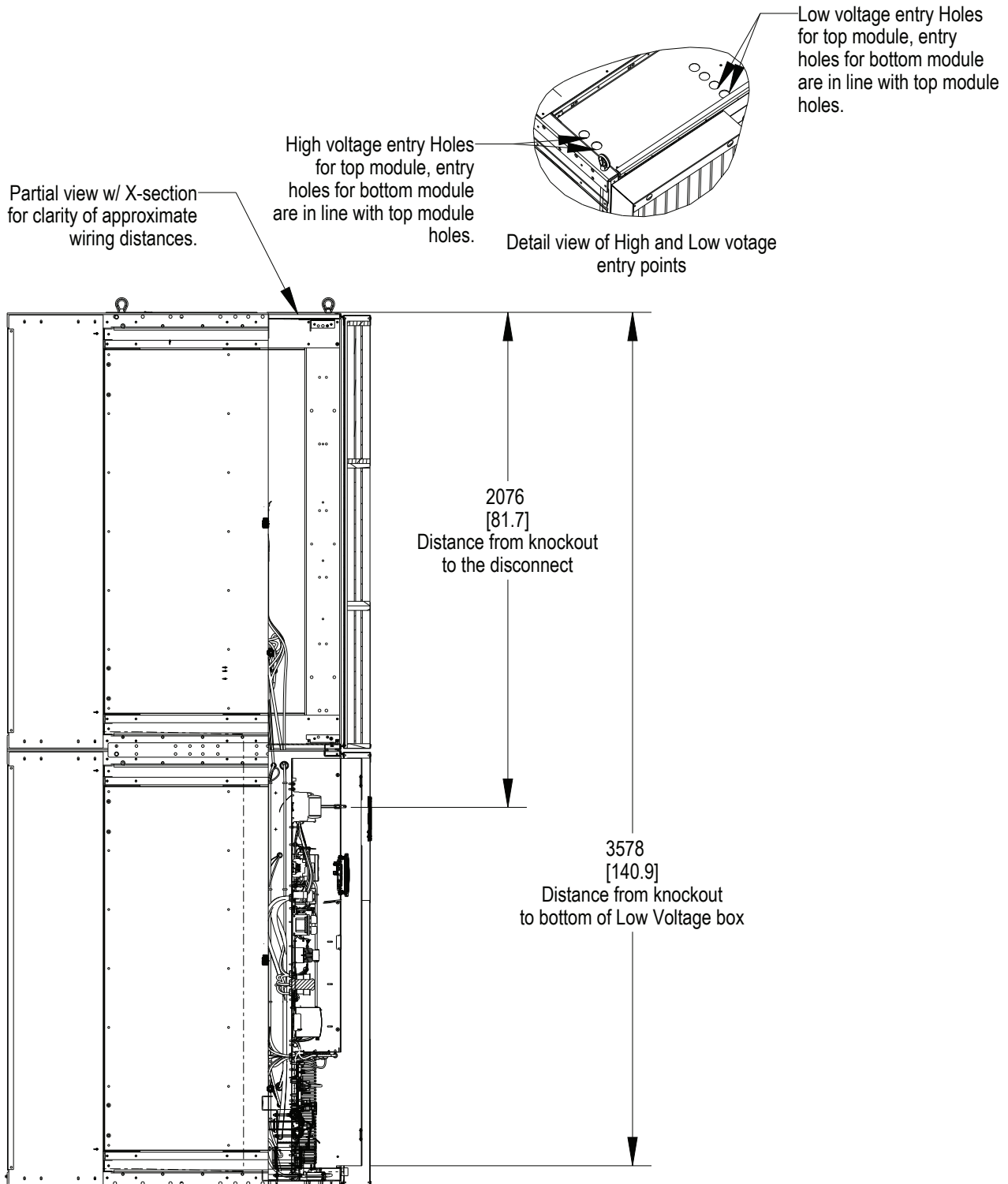

Note:

1. Filter and Filter rack assembly must be removed to access internal Electrical knockout



Cool Loop Thermal Wall

ELECTRICAL DATA

Model	Fan Type	Voltage	w/o Condensate Pump			w Condensate Pump			SCCR (kA)
			FLA	WSA	OPD	FLA	WSA	OPD	
CA60	High Airflow High Efficiency Fan	460V/60Hz	31.2	32.5	35	32.4	33.7	35	65
		575V/60Hz	25	26	30	25.9	26.9	30	65
		380V/60Hz	35.4	36.9	40	36.6	38.1	40	65
		380-415V/50Hz	35.4	36.9	40	36.6	38.1	40	65
	High Airflow High Efficiency Fan + THD	460V/60Hz	31.2	32.5	35	32.4	33.7	35	65
		575V/60Hz	25	26	30	25.9	26.9	30	65
		380V/60Hz	35.4	36.9	40	36.6	38.1	40	65
		380-415V/50Hz	35.4	36.9	40	36.6	38.1	40	65
CA80	Ultra Performance Fan	460V/60Hz	48	49.5	50	49.2	50.7	60	65
		575V/60Hz	38.4	39.6	40	39.3	40.5	45	65
		380V/60Hz	59.2	61.1	70	60.4	62.3	70	65
		380-415V/50Hz	59.2	61.1	70	60.4	62.3	70	65
	Ultra Performance Fan + THD	460V/60Hz	46.4	47.9	50	47.6	49.1	50	65
		575V/60Hz	37.6	38.8	40	38.5	39.7	40	65
		380V/60Hz	59.2	61.1	70	60.4	62.3	70	65
		380-415V/50Hz	59.2	61.1	70	60.4	62.3	70	65
	High Airflow High Efficiency Fan	460V/60Hz	41.6	42.9	45	42.8	44.1	45	65
		575V/60Hz	33.3	34.3	35	34.2	35.2	40	65
		380V/60Hz	47.2	48.7	50	48.4	49.9	50	65
		380-415V/50Hz	47.2	48.7	50	48.4	49.9	50	65
	High Airflow High Efficiency Fan + THD	460V/60Hz	41.6	42.9	45	42.8	44.1	45	65
		575V/60Hz	33.3	34.3	35	34.2	35.2	35	65
		380V/60Hz	47.2	48.7	50	48.4	49.9	50	65
		380-415V/50Hz	47.2	48.7	50	48.4	49.9	50	65

CoolLoop Thermal Wall

CA60 PRIMARY CONNECTION LOCATIONS WITH BRAZED CUSTOMER CONNECTIONS

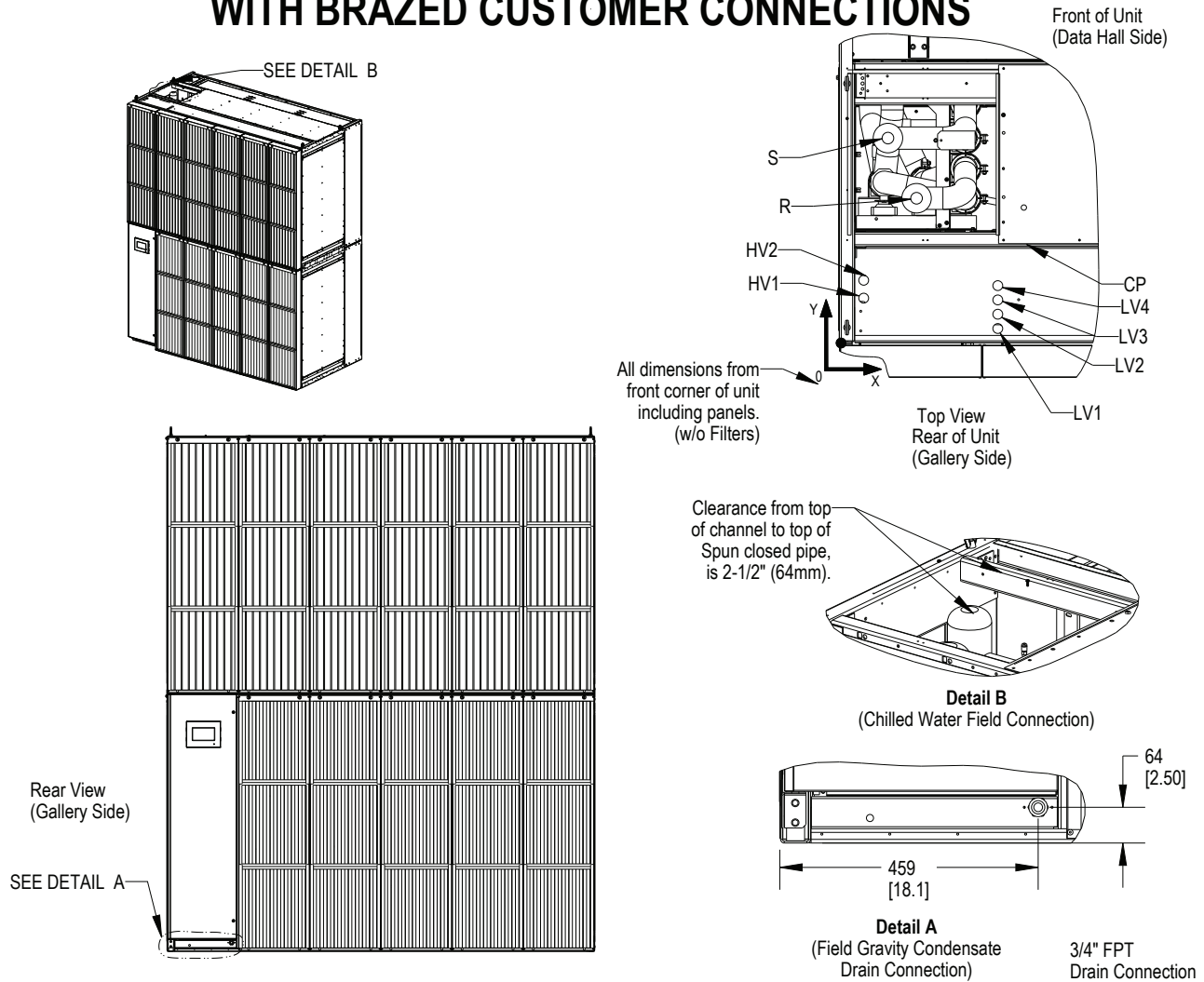

Connection	Description	X mm (in.)	Y mm (in.)	Connection Size Opening in.
R	Return Pipe Connection	274 (10.8)	513 (20.2)	4" O.D. CU
S	Supply Pipe Connection	173 (6.8)	726 (28.6)	
LV1	Electrical Connection (Low Volt)	564 (22.2)	51 (2.0)	1-3/8
LV2			102 (4.0)	
LV3			152 (6.0)	
LV4			203 (8.0)	
HV1	Electrical Connection (High Volt)	86 (3.4)	157 (6.2)	1/2" O.D. CU
HV2			221 (8.7)	
CP	Condensate Pump Connection	655 (25.8)	480 (18.9)	

Notes:

1. Drawing not to scale. All dimensions from left corner on Gallery Side and have a tolerance of $\pm 1/2"$ (13mm).
2. The factory unit does not contain a trap. The drain must comply with all local codes. Select appropriate drain system materials. Field pitch Condensate Drain line a minimum 1/8" (3mm) per 12" (305mm).
3. Piping connection can be made at the top of the unit.

CA60 PRIMARY CONNECTION LOCATIONS WITH BRAZED CUSTOMER CONNECTIONS CHILLED WATER COIL DRAIN DETAIL

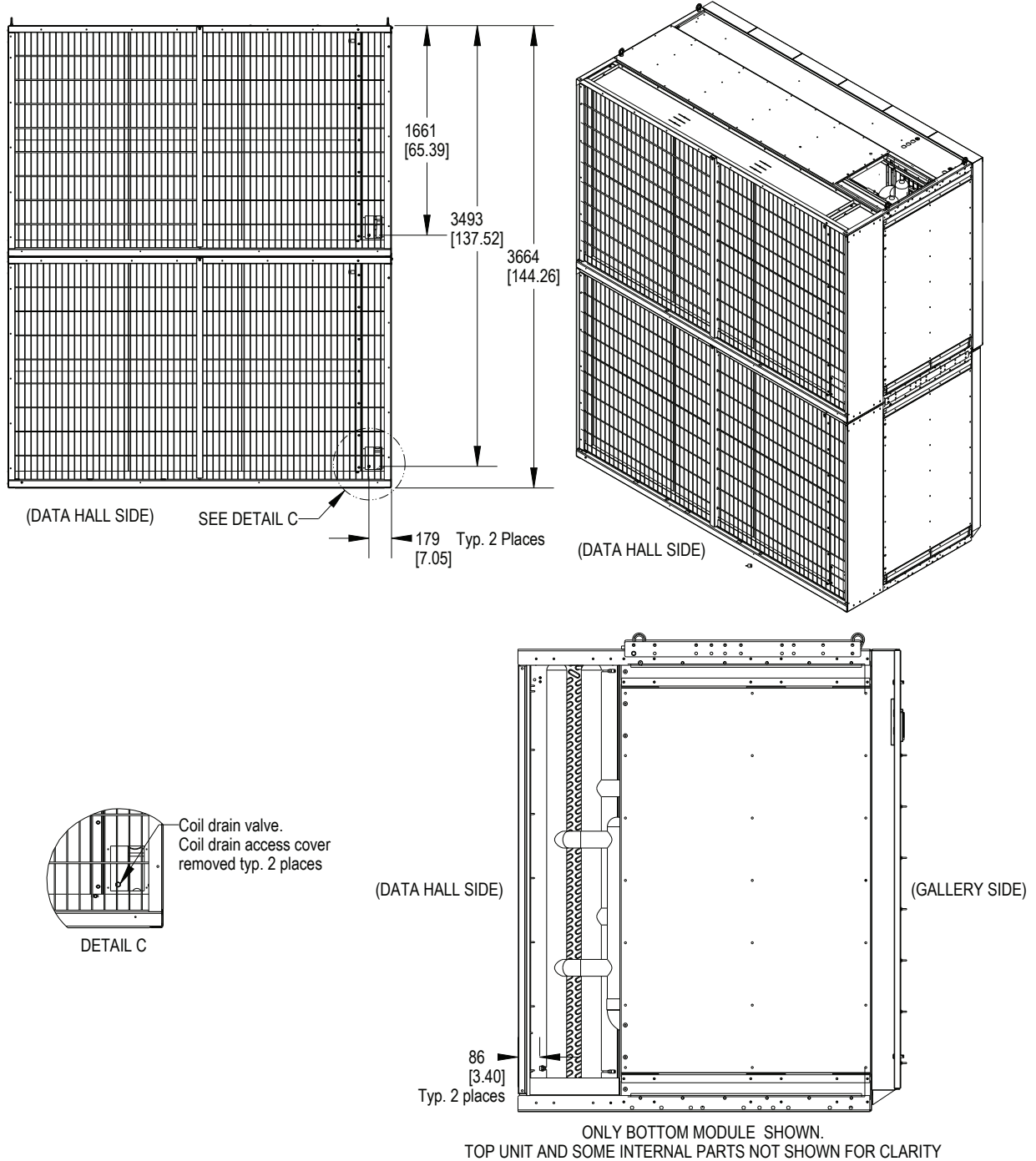

Notes:
1. Drawing not to scale.

CoolLoop Thermal Wall

CA60 PRIMARY CONNECTION LOCATIONS WITH FLANGED CUSTOMER CONNECTIONS

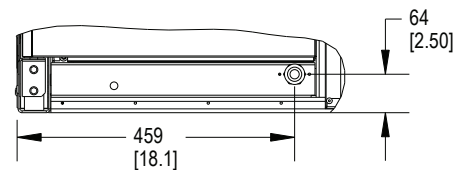
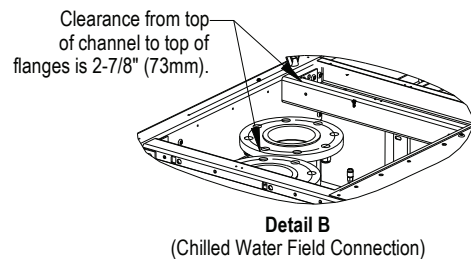
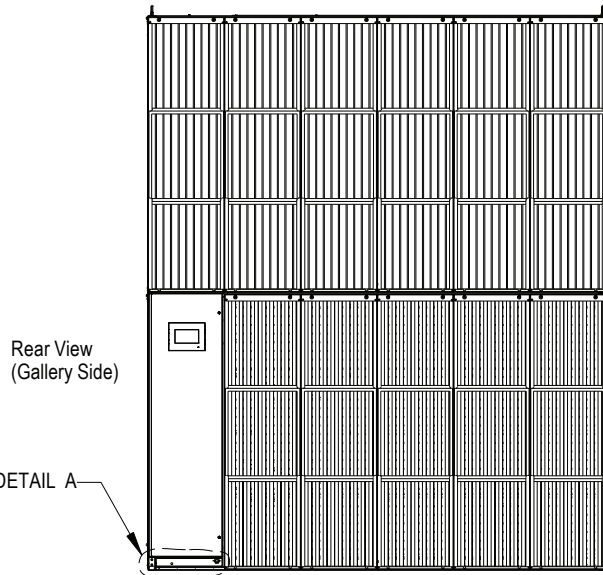
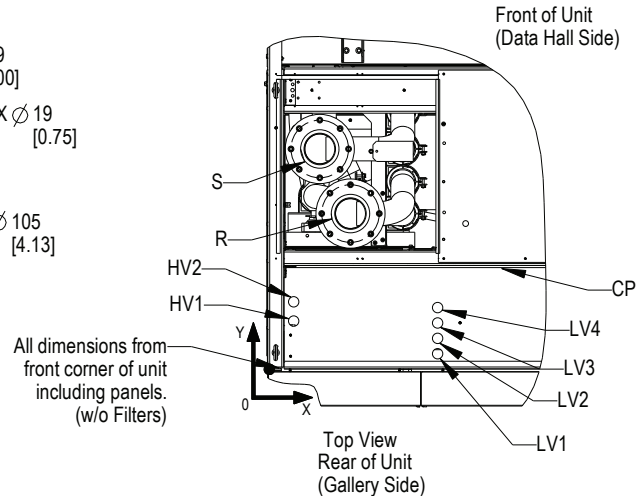
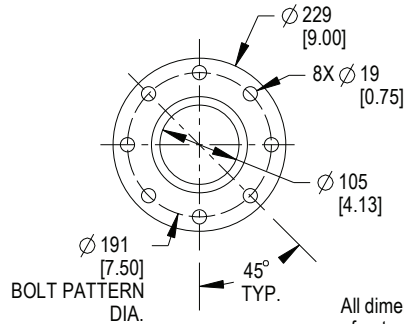
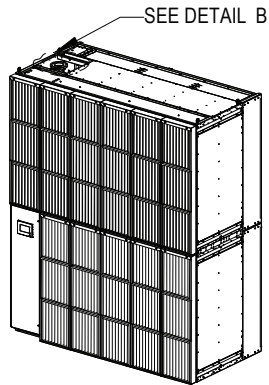

Detail A
(Field Gravity Condensate Drain Connection)

3/4" FPT Drain Connection

Connection	Description	X mm (in.)	Y mm (in.)	Connection Size Opening in.
R	Return Pipe Connection	274 (10.8)	513 (20.2)	4" WF-150 Style Flat Flange
S	Supply Pipe Connection	175 (6.9)	727 (28.6)	
LV1	Electrical Connection (Low Volt)	564 (22.2)	51 (2.0)	1-3/8
LV2			102 (4.0)	
LV3			152 (6.0)	
LV4			203 (8.0)	
HV1	Electrical Connection (High Volt)	86 (3.4)	157 (6.2)	
HV2			221 (8.7)	
CP	Condensate Pump Connection	655 (25.8)	480 (18.9)	1/2" O.D. CU

Notes:

- Drawing not to scale. All dimensions from left corner on Gallery Side and **have a tolerance of ±1/2" (13mm)**.
- The factory unit does not contain a trap. The drain must comply with all local codes. Select appropriate drain system materials. Field pitch Condensate Drain line a minimum 1/8" (3mm) per 12" (305mm).
- Piping connection can be made at the top of the unit.

CoolLoop Thermal Wall

CA60 PRIMARY CONNECTION LOCATIONS WITH FLANGED CUSTOMER CONNECTIONS CHILLED WATER COIL DRAIN DETAIL

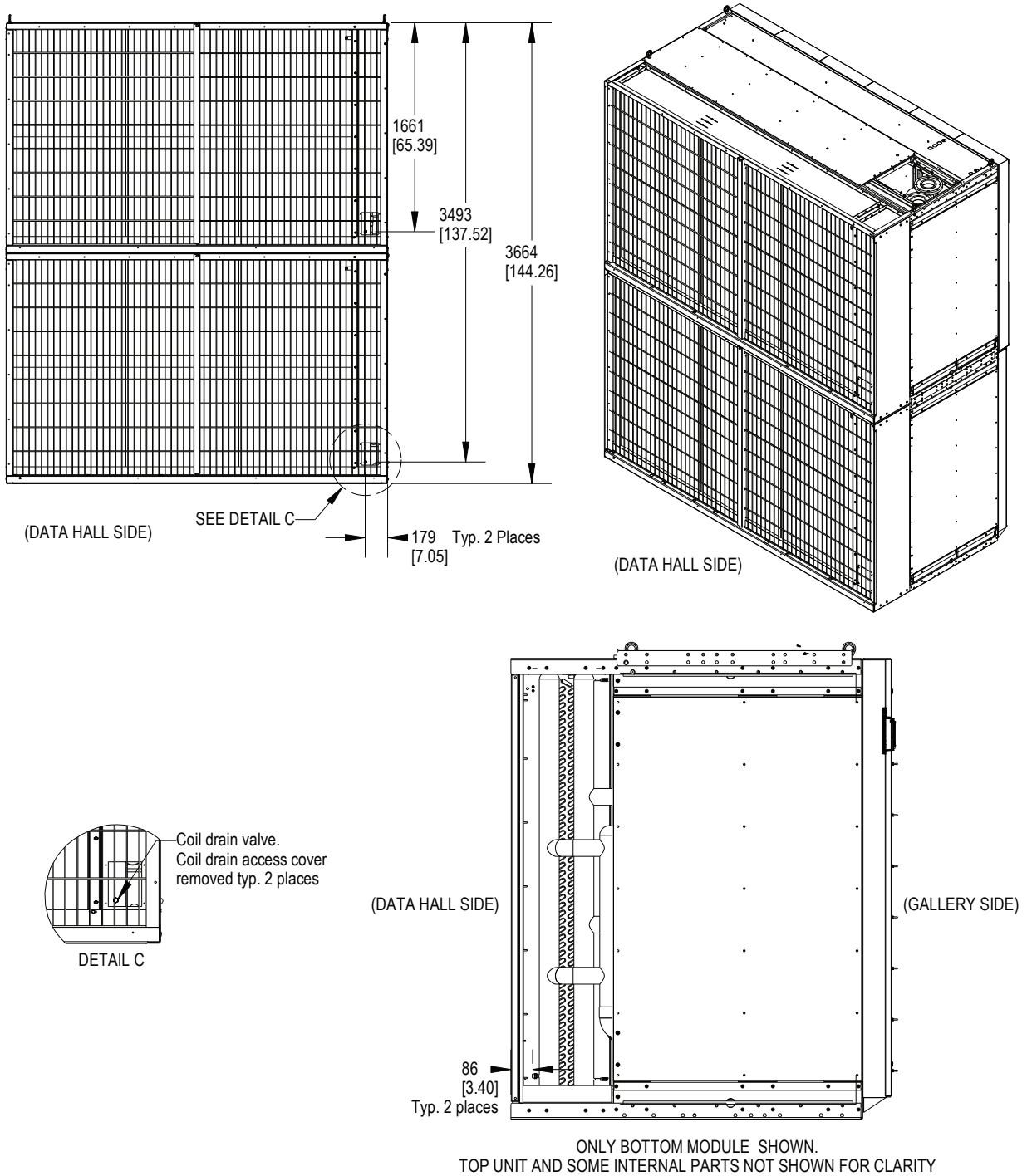

Notes:
1. Drawing not to scale.

AUTOMATIC TRANSFER SWITCH

CONTROL MODULE

OVERVIEW OF LOVATO ATS, MODELS ATL610 & ATL800

Vertiv™ Thermal Management units equipped with the optional Lovato ATS (automatic transfer switch) control, will automatically switch over to a secondary power source upon loss of primary power. It will also return to the primary power source when it is determined it is available.

When units are equipped with the optional Capacitive Buffer feature, it will not only keep the Vertiv™ iCOM™ control powered (minimum of 3 minutes) during a loss of power, but will also keep the ATS electronics powered when neither the primary or secondary source are available, allowing for a quick unit response when power is restored.

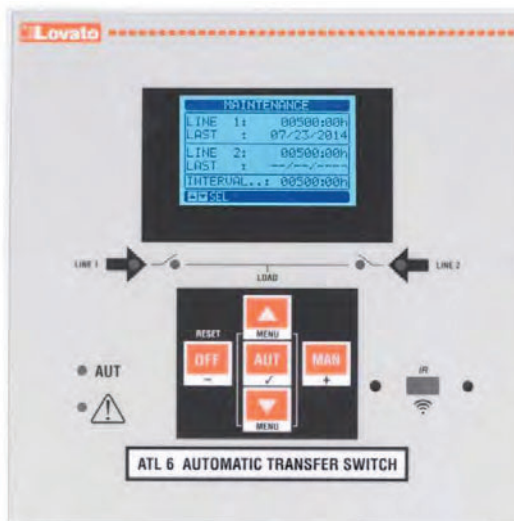

ATL610 (Units up to 460V)

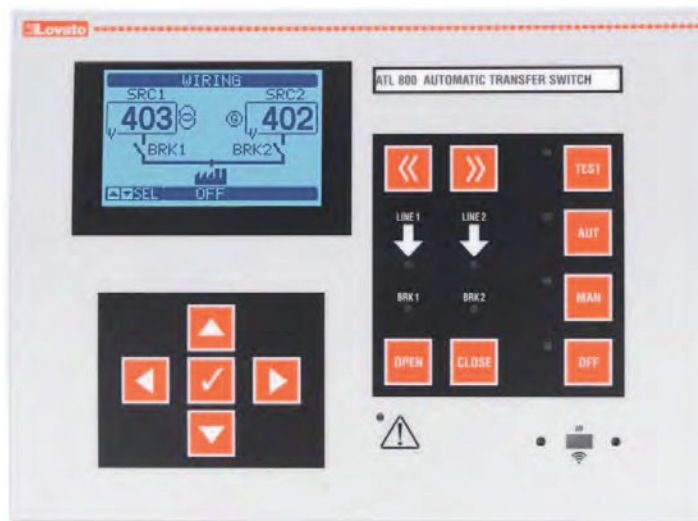

ATL800 (575V Units)

Lovato ATS, model ATL610 (or ATL800) shown in images above, will be located within the cabinet of the units.

AUTOMATIC TRANSFER SWITCH

CONTROL MODULE

KEY CAPABILITIES OF LOVATO ATS, MODELS ATL610 & ATL800

The Lovato ATS, model ATL610 (or ATL800), will be the primary unit level device for switching between power sources. This control will be capable of the following features:

- Determine if power is available in both primary and secondary sources
- Allow for selection of which source is primary and which is secondary
- Ability to automatically switch from primary to secondary source, in the event of primary power loss
- Ability to automatically switch secondary to primary source when primary power returns
- Visible indication of available power sources
- Visible indication of power source that is currently active

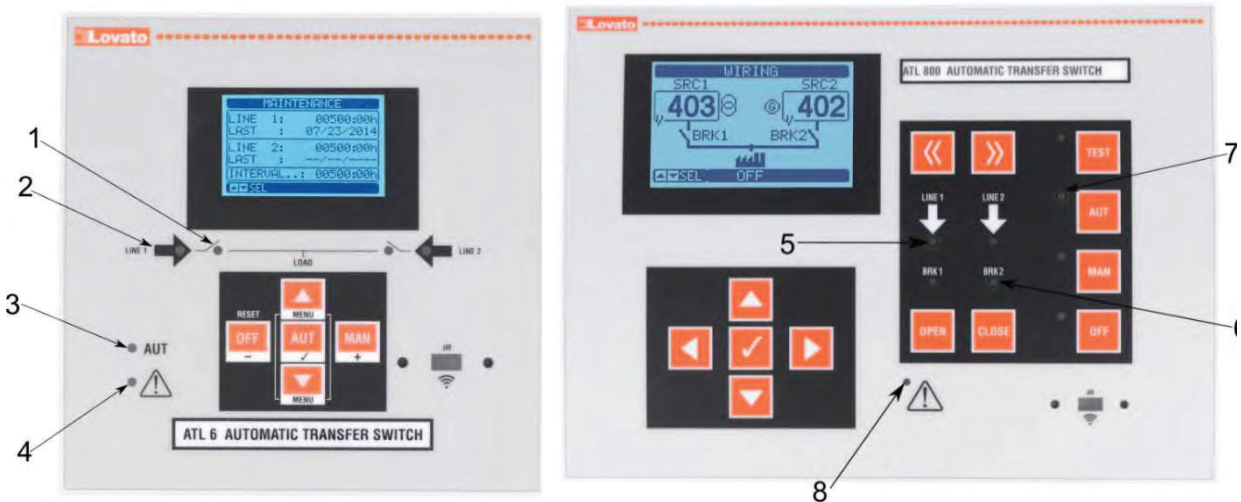

Item #	Description for ATL610 Display	Item #	Description for ATL800 Display
1	LEDs indicate which source is active	5	LEDs indicate if a source is available
2	LEDs indicate if a source is available	6	LEDs indicate which source is active
3	Controller is in automatic mode	7	Controller is in automatic mode
4	Alarm is present	8	Alarm is present

ATL610 (Units up to 460V)

ATL800 (575V Units)

CONTROL MODULE

INTERACTION OF LOVATO ATS WITH VERTIV™ iCOM™ CONTROL

The Vertiv™ iCOM™ control will pull key information from the Lovato ATS, allowing for easy interpretation of the current operation without needing to open the unit's front panel, potentially interrupting operation.

*Identification of current power source and power source availability

*Available via PA2.06.54.04R or greater



Power source availability

- GREEN circle w/ check mark = power source available
- RED circle w/ cross = power source not available

Power Source A/B utilization

- ORANGE highlighted & underlined power source title = current power source being utilized.

AUTOMATIC TRANSFER SWITCH

CONTROL MODULE

KEY PARAMETERS OF LOVATO ATS, MODELS ATL610 & ATL800

There are multiple key parameters that are factory set by Vertiv to recommended values. Please consult a Vertiv factory technician before making any changes to these parameters.

- Priority power source selection (default = Source 1)
- Switching delay between power sources
 - if secondary power source is present at time of primary failure, delay is up to 11s (default, adjustable via multiple parameters)
 - if secondary power source is ***NOT*** present at time of primary failure, delay is 10s (default, adjustable) after secondary power source is available
- Unit would be removed from active power source in following conditions:
 - Voltage Limit: If voltage is outside of a set limit for a set period (default = 5s)
 - Min Voltage Limit = 85% (default) of nominal
 - Max Voltage Limit = 115% (default) of nominal
 - Voltage Imbalance: If voltage imbalance (asymmetry) is greater than 15% (default) for a set period (default = 5s)
 - Phase Loss: If a phase falls below 70% (default) of nominal for a set period (default = 0.1s)
 - Frequency Limit: If frequency is outside of a set limit for a set period (default = 3s)
 - Min Freq Limit = 95% (default)
 - Max Frequency Limit = 105% (default)

Please note that not all parameters are applicable to Vertiv equipment operation. Consult a Vertiv factory technician before making any changes to these parameters.

AUTOMATIC TRANSFER SWITCH

CONTROL MODULE

MONITORING FUNCTIONS OF LOVATO ATS, MODELS ATL610 & ATL800

The voltage and frequency information from the ATS can be displayed on the Vertiv™ iCOM™ user interface, as shown in the below image. Further information is available via BMS monitoring through the Vertiv™ iCOM™ Unity Card / Embedded Unity (BACnet MSTP, BACnet IP, Modbus TCP/IP, Modbus RTU, SNMP v2, v3). The items are outlined in the table on the following page.

ATS voltage & frequency summary page

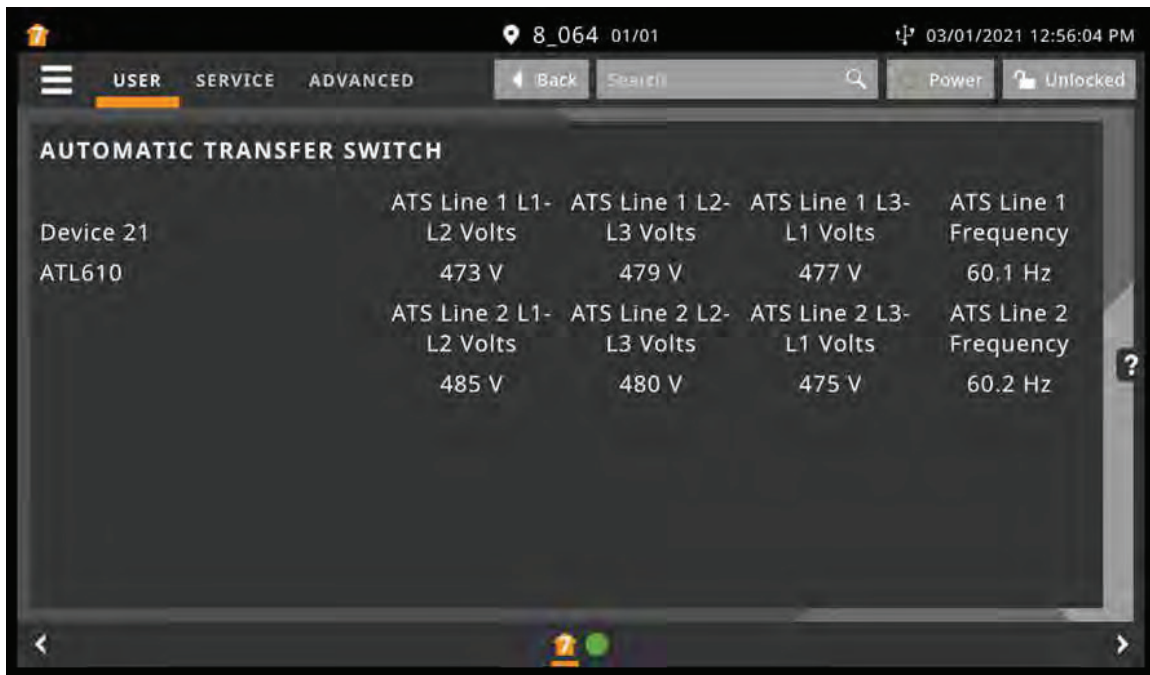

Device 21	ATS Line 1 L1- L2 Volts	ATS Line 1 L2- L3 Volts	ATS Line 1 L3- L1 Volts	ATS Line 1 Frequency
ATL610	473 V	479 V	477 V	60.1 Hz
	ATS Line 2 L1- L2 Volts	ATS Line 2 L2- L3 Volts	ATS Line 2 L3- L1 Volts	ATS Line 2 Frequency
	485 V	480 V	475 V	60.2 Hz



AUTOMATIC TRANSFER SWITCH

CONTROL MODULE MONITORING POINTS

The below ATS specific points can be monitored through a BMS system. Alarm codes at the ATS panel will not match the BMS alarm but can be cross referenced in this chart. Please note that these points are read only.

Lovato Code (at ATS)	Vertiv Alarm (BMS)	Description
ATS_EvLdTO	ATS Load Not Powered Timeout	Unit has not been powered after preset delay (default = 60s).
ATS1_L1L2	Power Source: L1-L2 voltage	Voltage reading phase L1-L2
ATS1_L2L3	Power Source: L2-L3 voltage	Voltage reading phase L2-L3
ATS1_L3L1	Power Source: L3-L1 voltage	Voltage reading phase L3-L1
ATS1_Freq	Power Source: Line Frequency	Measured frequency, per source.
ATS1_BrkOp	Power Source: Breaker Operation Count	Available to be turned on by customer, would indicate number of operations per source.
ATS1VAIOk	Power Source: All status are okay	All parameters are within limits, per source.
ATS1VLo	Power Source: Voltage Is Too Low	Voltage on active source is below acceptable range.
ATS1VHi	Power Source: Voltage Is Too High	Voltage on active source is above acceptable range.
ATS1VAAsymm	Power Source: Voltages Are Asymmetric	Voltages imbalance alarm
ATS1VPhsLs	Power Source: Voltage Phase Loss	Indicates one of the phases voltage has dropped below 70% nominal.
ATS2VPhsSq	Power Source: Phase Sequence Issue	Indicates the incoming power wasn't wired per the phase sequence configured (L1-L2-L3).
ATS1VFrqLo	Power Source: Frequency Is Too Low	Frequency on active source is below acceptable range.
ATS1VFrqHi	Power Source: Frequency Is Too High	Frequency on active source is above acceptable range.
ATS2BCIsd	Power Source: Breaker is closed	ATS is receiving feedback that the indicated contactor as closed.
ATS2BCCIsd	Power Source: Breaker command status closed	ATS is directing the indicated contactor to close.
ATS1EvBTim	Power Source: Breaker Timeout Issue	The indicated changeover device did not complete the

AUTOMATIC TRANSFER SWITCH

CONTROL MODULE

CHANGE OVER CIRCUIT SEQUENCE OF OPERATIONS

Source 1 is out of range

- 1) Source 1 exceeds one or more limits of voltage, frequency, phase, or voltage symmetry.
- 2) A delay timer will begin to count. The amount of time depends on which Source 1 parameter is out of spec, and the value saved in the following parameters. The parameters below are the delays for each condition.

Description	Default	Parameter	
		ATL610	ATL800
Voltage below the minimum limit	5s	P06.03	P09.01.03
Voltage above the maximum limit	5s	P06.06	P09.01.06
Phase failure	0.1s	P06.10	P09.01.10
Voltage exceeds the asymmetry limits	5s	P06.12	P09.01.12
Frequency exceeds the maximum limit	3s	P06.14	P09.01.14
Frequency exceeds the minimum limit	5s	P06.16	P09.01.16

- 3) Once the delay timer is finished, the following events will occur.
 - a. The transfer controller will de-energize Source 1 contactor coil.
 - b. The transfer controller will signal the unit is no longer being powered by Source 1.
 - c. An auxiliary switch NO contact on Source 1's contactor will open, sending a signal to the transfer controller. This signal verifies that the load is not connected to Source 1.
 - d. The NC contacts of the same auxiliary switch will close to allow the coil of the Source 2 contactor to be energized. The Source 2 contactor coil is not energized at this time.
- 4) Once the transfer controller output has opened, a delay timer will begin using the value entered under parameter P05.03 (ATL610) or P07.01.02 (ATL800), default = 6s. **This value should not be decreased without consent from Vertiv.**
- 5) A presence delay is used to determine if Source 2 is a valid source. This delay will start as soon as Source 2 is available. The presence delay is based on the value entered in parameter P07.07 (ATL610) or P09.02.07 (ATL800), default = 10s. If Source 2 is available before Source 1 fails, it is possible that the delay will already be satisfied at the time Source 1 fails. If this is a manual transfer to Source 2 and Source 1 is still available, the presence delay will refer to the value in parameter P07.08 (ATL610) or P09.02.08 (ATL800), default = 60s.
- 6) When the timer in both step 4 and 5 are finished:
 - a. The transfer controller will energize the Source 2 contactor.
 - b. An auxiliary switch NO contact on Source 2's contactor will close, sending a signal to the transfer controller. This signal verifies that the load is connected to Source 2.
 - c. The NC contacts of the same auxiliary switch will open to prevent the coil of Source 1 contactor from energizing.
 - d. The transfer controller will signal the unit is being powered by Source 2.

AUTOMATIC TRANSFER SWITCH

CONTROL MODULE

CHANGE OVER CIRCUIT SEQUENCE OF OPERATIONS

Transfer back to Source 1 when Source 2 is present

- 1) When Source 1 has reached acceptable levels, a presence delay will start. The presence delay is based on the value entered in parameter P06.08 (ATL610) or P09.01.08 (ATL800), default = 60s.
- 2) Once this timer is finished:
 - a. The transfer controller will de-energize Source 2 contactor coil.
 - b. An auxiliary switch NO contact on Source 2's contactor will open, sending a signal to the transfer controller. This signal verifies that the load is not connected to Source 2.
 - c. The NC contacts of the same auxiliary switch will close to allow the coil of the Source 1 contactor to be energized. The Source 1 contactor coil is not energized at this time.
 - d. The transfer controller will signal the unit is no longer being powered by Source 2.
- 3) A delay timer starts using the value in parameter P05.04 (ATL610) or P07.02.02 (ATL800), default = 6s. **This value should not be decreased without consent from Vertiv.**
- 4) When the timer in step 3 is finished:
 - a. The transfer controller will energize the Source 1 contactor.
 - b. An auxiliary switch NO contact on Source 1's contactor will close, sending a signal the transfer controller. This signal verifies that the load is connected to Source 1.
 - c. The NC contacts of the same auxiliary switch will open to prevent the coil of Source 2 contactor from energizing.
 - d. The transfer controller will signal the unit is being powered by Source 1.

AUTOMATIC TRANSFER SWITCH

CONTROL MODULE

CHANGE OVER CIRCUIT SEQUENCE OF OPERATIONS

Source 2 is out of range when unit is powered by Source 2

- 1) Source 2 exceeds one or more limits of voltage, frequency, phase, or voltage symmetry.
- 2) A delay timer will begin to count. The amount of time depends on which Source 2 parameter is out of spec, and the value saved in the following parameters. The parameters below are the delays for each condition.

Description	Default	Parameter	
		ATL610	ATL800
Voltage below the minimum limit	5s	P07.03	P09.02.03
Voltage above the maximum limit	5s	P07.06	P09.02.06
Phase failure	0.1s	P07.10	P09.02.10
Voltage exceeds the asymmetry limits	5s	P07.12	P09.02.12
Frequency exceeds the maximum limit	3s	P07.14	P09.02.14
Frequency exceeds the minimum limit	5s	P07.16	P09.02.16

- 3) Once the delay timer is finished, the following events will occur:
 - a. The transfer controller will de-energize Source 2 contactor coil.
 - b. The transfer controller will signal the unit is no longer being powered by Source 2.
 - c. An auxiliary switch NO contact on Source 2's contactor will open, sending a signal to the transfer controller. This signal verifies that the load is not connected to Source 2.
 - d. The NC contacts of the same auxiliary switch will close to allow the coil of Source 1 contactor to be energized. The Source 1 contactor coil is not energized at this time.
- 4) Once the transfer controller output has opened, a delay timer will begin using the value entered under parameter P05.04 (ATL610) or P07.02.02 (ATL800), default = 6s. This value should not be decreased without consent from Vertiv.
- 5) A presence delay is used to determine if Source 1 is a valid source. This delay will start as soon as Source 1 is available. The presence delay is based on the value entered in parameter P06.07 (ATL610) or P09.01.07 (ATL800), default = 10s. If Source 1 is available before Source 2 fails, it is possible that the delay will already be satisfied at the time Source 2 fails. If this is a manual transfer to Source 1 and Source 2 is still available, the presence delay will refer to the value in parameter P06.08 (ATL610) or P09.01.08 (ATL800), default = 60s.
- 6) When the timer in both steps 4 and 5 are finished:
 - a. The transfer controller will energize the Source 1 contactor.
 - b. An auxiliary switch NO contact on Source 1's contactor will close, sending a signal to the transfer controller. This signal verifies that the load is connected to Source 1.
 - c. The NC contacts of the same auxiliary switch will open to prevent the coil of Source 2 contactor from energizing.
 - d. The transfer controller will signal the unit is being powered by Source 1.

Transfer when Source 1 and Source 2 fails

- 1) If both Source 1 and Source 2 fail and are restored, the transfer controller will transfer the load to the preferred Source defined in parameter P05.02 (ATL610) or P06.01.02/P06.02.02 (ATL800), default = 1.

AUTOMATIC TRANSFER SWITCH

CONTROL MODULE

TRANSFER CONTROLLER TERMINAL LABELS – ATL610

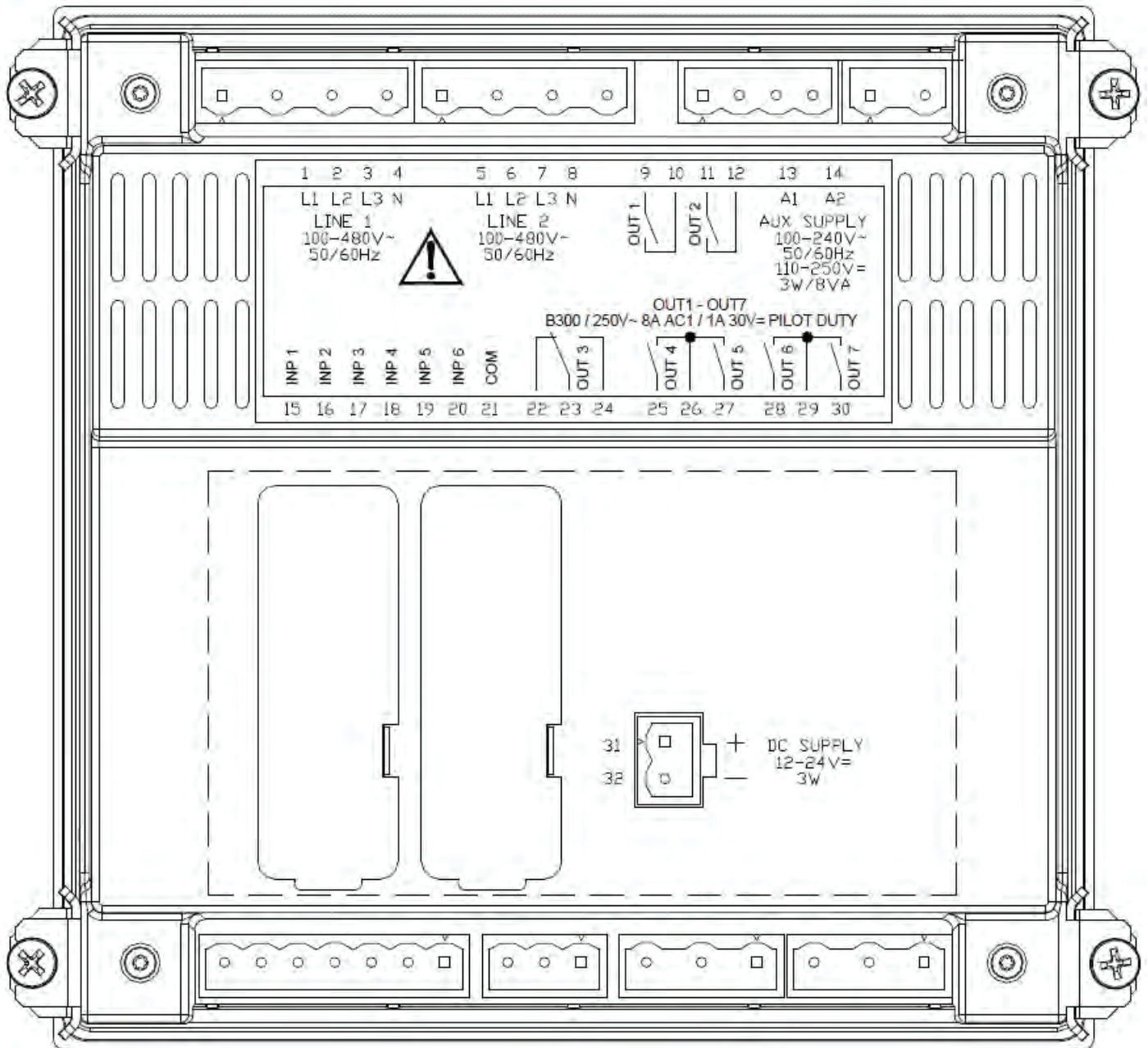



AUTOMATIC TRANSFER SWITCH

CONTROL MODULE

TRANSFER CONTROLLER TERMINAL LABELS – ATL800

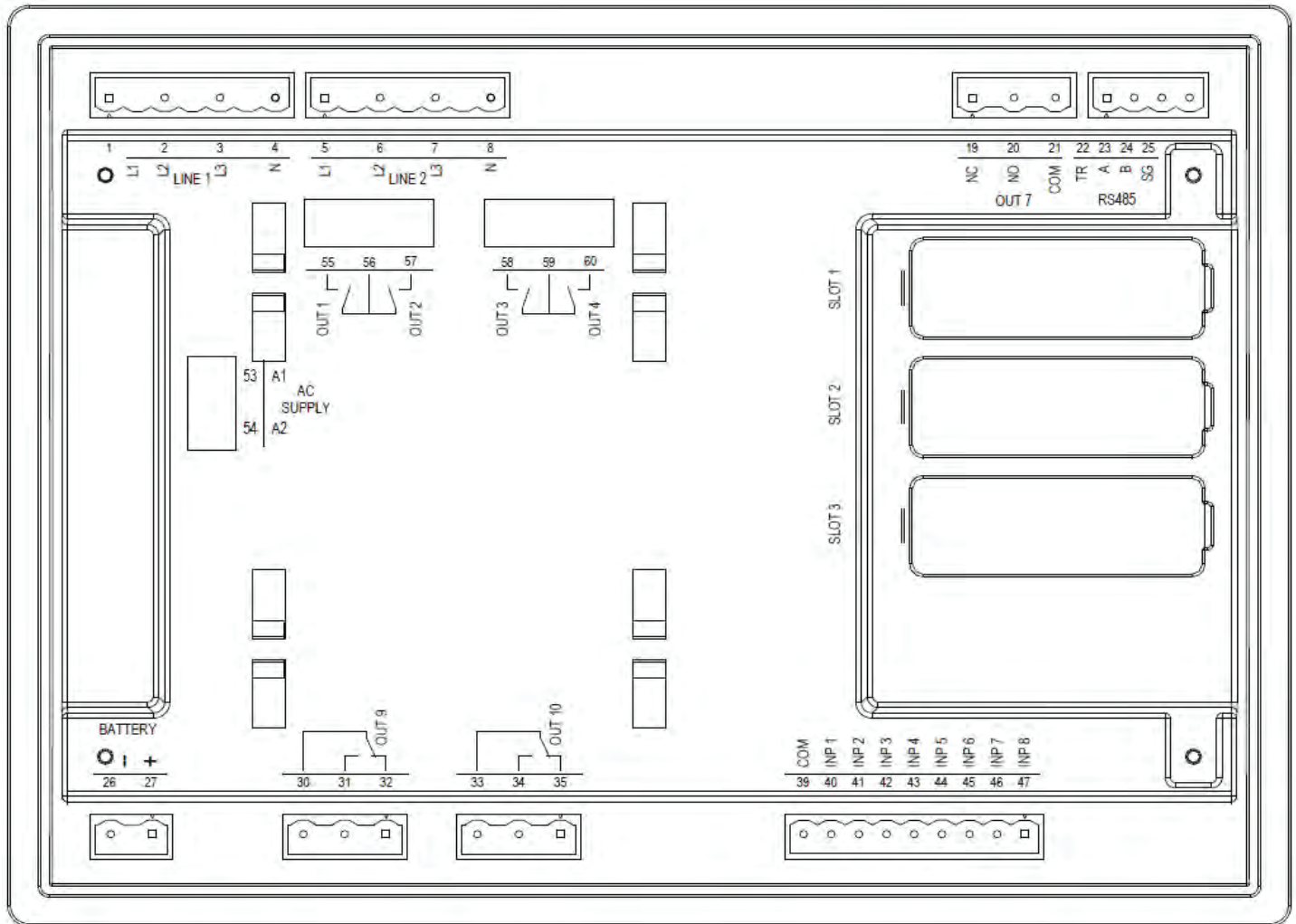



CoolLoop Thermal Wall

CA60 THD MITIGATION HIGH AIRFLOW HIGH EFFICIENCY FAN

IEEE Std 519-2014 defines the maximum voltage distortion limits allowed to be reflected onto the utility distribution system at the point of common coupling (PCC). It is a guideline meant to minimize the effects of electrical pollution created by one utility customer from affecting a different customer.

The guideline requires total voltage harmonic distortion (THD) conform to the limits shown in Table 1.

Table 1 - Voltage distortion limits

Bus voltage V at PCC	Individual Harmonic (%)	Total harmonic distortion THD (%)
V ≤ 1.0 kV^b	5.0	8.0
1 kV < V ≤ 69 kV	3.0	5.0
69 kV < V ≤ 161 kV	1.5	2.5
161 kV < V	1.0	1.5 ^a

^aHigh-voltage systems can have up to 2.0% THD where the cause is an HVDC terminal whose effects will have attenuated at points in the network where future users may be connected.

^bVertiv™ CoolLoop Thermal Wall units fall under the limits for V ≤ 1.0 kV

The individual harmonic current distortion and total current demand distortion (TDD) conform to the limits shown in Table 2.

Table 2 - Current distortion limits for systems rated 120 V through 69 kV

Maximum harmonic current distortion in percent of I _L						
Individual harmonic order (odd harmonics) ^{a,b}						
I _{sc} / I _L	3 ≤ h < 11	11 ≤ h < 17	17 ≤ h < 23	23 ≤ h < 135	35 ≤ h < 50	TDD
< 20 ^c	4.0	2.0	1.5	0.6	0.3	5.0
20 < 50	7.0	3.5	2.5	1.0	0.5	8.0
50 < 100	10.0	4.5	4.0	1.5	0.7	12.0
100 < 1000^d	12.0	5.5	5.0	2.0	1.0	15.0
> 1000	15.0	7.0	6.0	2.5	1.4	20.0

^aEven harmonics are limited to 25% of the odd harmonic limits above.

^bCurrent distortions that result in a dc offset, e.g., half-wave converters, are not allowed.

^cAll power generation equipment is limited to these values of current distortion, regardless of actual I_{sc} / I_L, where

I_{sc} = maximum short-circuit current at PCC (determined by building short circuit analysis)

I_L = maximum demand load current (fundamental frequency component)
at the PCC under normal load operating conditions

^dVertiv™ CoolLoop Thermal Wall units typically fall under the limits for 100 < 1000, assuming I_{sc} ≥ 3,500 amps

It is **NOT** a guideline for individual connected loads, but a guideline for a total building or plant. Many apply the voltage distortion criteria to all substations, and apply the current distortion criteria exclusively to the utility metering point.

Typically, if the variable speed fan load is less than 10% of the current capacity at the point of common coupling (PCC), your installation will meet IEEE-519 guidelines. In this case you should have no interference issues with other electrical equipment.

Typically, the worst case PCC is the emergency backup generator plant but could be the transformer which powers the cooling load. If the PCC is a UPS unit, consult your UPS supplier for recommendations. For customers who have variable speed loads that exceed this rule of thumb, it may be necessary to minimize the harmonic impact these variable speed loads have on the system voltage. In these instances, an undesirable effect is a difficulty in switching from generator supply back to utility supply. The purpose of the Vertiv™ CoolLoop Thermal Wall THD mitigation device is to cancel current harmonics generated by the variable frequency drive. This device will not improve harmonics caused by other systems on the power network.



CoolLoop Thermal Wall

CA60 THD MITIGATION HIGH AIRFLOW HIGH EFFICIENCY FAN

Below are the Total Voltage Distortion levels as measured on a single CA60 unit with high airflow, high-efficiency fans. This data is typical of what can be expected in the field. Values may vary depending on operating conditions. Applicable to both the factory installed THD mitigation filter and the integrated THD mitigation fan option.

WARNING: A passive harmonic filter raises the voltage to the fan by 20-30V. This difference requires that the input voltage be limited to +5%, -10% on 460V and 575V units. If the input voltage is above +5% of the rated voltage, disconnect the capacitor contactor coil from the circuit.

Typical Total Voltage Distortion for CA60 with High Airflow, High Efficiency Fans at 460 Volts:

Voltage Harmonic List — 100% Fan Speed						
Without Mitigation Device						
Order	L1		L2		L3	
	Volts	% Distortion	Volts	% Distortion	Volts	% Distortion
1	475.85		474.21		473.43	
5	4.35	0.91%	4.15	0.87%	4.86	1.03%
7	7.51	1.58%	6.24	1.32%	6.54	1.38%
11	4.66	0.98%	4.62	0.97%	4.95	1.04%
13	1.82	0.38%	1.72	0.36%	2.27	0.48%
17	3.93	0.82%	4.11	0.87%	4.10	0.87%
Total THD (%)	2.81%		2.71%		2.76%	
With Mitigation Device						
Order	L1		L2		L3	
	Volts	% Distortion	Volts	% Distortion	Volts	% Distortion
1	473.94		473.88		473.31	
5	4.23	0.89%	3.67	0.78%	4.44	0.94%
7	6.17	1.30%	5.24	1.11%	5.18	1.10%
11	3.67	0.77%	3.64	0.77%	4.00	0.85%
13	0.78	0.17%	0.87	0.18%	1.08	0.23%
17	2.44	0.52%	2.50	0.53%	2.44	0.52%
Total THD (%)	2.47%		2.48%		2.37%	

Voltage Harmonic List — 50% Fan Speed						
Without Mitigation Device						
Order	L1		L2		L3	
	Volts	% Distortion	Volts	% Distortion	Volts	% Distortion
1	478.98		474.86		476.71	
5	3.14	0.66%	3.05	0.64%	3.67	0.77%
7	5.46	1.14%	4.18	0.88%	4.13	0.87%
11	1.56	0.33%	1.28	0.27%	1.64	0.34%
13	0.98	0.21%	0.76	0.16%	0.88	0.18%
17	0.29	0.06%	0.11	0.02%	0.20	0.04%
Total THD (%)	2.01%		1.91%		1.88%	
With Mitigation Device						
Order	L1		L2		L3	
	Volts	% Distortion	Volts	% Distortion	Volts	% Distortion
1	474.29		474.83		475.18	
5	2.67	0.56%	2.54	0.54%	3.25	0.68%
7	4.56	0.96%	3.61	0.76%	3.50	0.74%
11	1.78	0.38%	1.89	0.40%	2.20	0.46%
13	0.67	0.14%	0.52	0.11%	0.61	0.13%
17	0.59	0.12%	0.45	0.09%	0.55	0.11%
Total THD (%)	1.94%		2.01%		1.86%	



CoolLoop Thermal Wall

CA60 THD MITIGATION HIGH AIRFLOW HIGH EFFICIENCY FAN

Below are the Total Current Distortion levels as measured on a single CA60 unit with high airflow, high efficiency fans. This data is typical of what can be expected in the field. Values may vary depending on operating conditions. Applicable to both the factory installed THD mitigation filter and the integrated THD mitigation fan option.

Typical Total Current Distortion for CA60 with High Airflow, High Efficiency Fans at 460 Volts:

Current Harmonic List — 100% Fan Speed

Without Mitigation Device						
Order	L1		L2		L3	
	amps	% Distortion	amps	% Distortion	amps	% Distortion
1	24.77		24.57		24.84	
5	6.09	24.59%	37.43	24.90%	6.17	24.84%
7	6.49	26.22%	6.20	25.25%	6.52	26.26%
11	4.26	17.20%	4.34	17.66%	4.41	17.77%
13	3.40	13.72%	2.89	11.75%	3.27	13.18%
17	4.13	16.69%	4.31	17.55%	4.34	17.49%
Total THD (%)	46.62%		46.12%		47.25%	

With Mitigation Device						
Order	L1		L2		L3	
	amps	% Distortion	amps	% Distortion	amps	% Distortion
1	22.79		22.45		22.78	
5	0.82	3.61%	0.58	2.58%	0.79	3.47%
7	0.54	2.36%	0.48	2.16%	0.42	1.86%
11	0.42	1.84%	0.47	2.07%	0.40	1.74%
13	0.27	1.20%	0.26	1.16%	0.26	1.16%
17	0.01	0.05%	0.00	0.02%	0.01	0.06%
Total THD (%)	4.95%		4.31%		4.66%	

Current Harmonic List — 50% Fan Speed

Without Mitigation Device						
Order	L1		L2		L3	
	amps	% Distortion	amps	% Distortion	amps	% Distortion
1	6.40		6.06		6.45	
5	4.49	70.28%	4.33	71.45%	4.52	70.15%
7	3.74	58.53%	3.62	59.77%	4.02	62.32%
11	2.04	31.89%	2.04	33.58%	2.04	31.57%
13	1.23	19.20%	1.36	22.47%	1.42	21.96%
17	1.61	25.22%	1.53	25.31%	1.30	20.22%
Total THD (%)	119.97%		121.86%		123.98%	

With Mitigation Device						
Order	L1		L2		L3	
	amps	% Distortion	amps	% Distortion	amps	% Distortion
1	7.47		7.42		7.32	
5	0.32	4.35%	0.24	3.22%	0.32	4.38%
7	0.48	6.45%	0.50	6.72%	0.50	6.82%
11	0.24	3.17%	0.24	3.27%	0.24	3.27%
13	0.07	0.95%	0.07	0.99%	0.07	1.01%
17	0.03	0.39%	0.03	0.39%	0.03	0.35%
Total THD (%)	9.06%		8.88%		9.39%	

NOTE: Values shown at 50% fan speed are for reference only. At low demand, THD values will have a lower impact on the system than at full load.

UNIT TO UNIT NETWORK CONNECTIONS FOR CoolPhase Perimeter, CoolLoop Perimeter and CoolLoop Thermal Wall

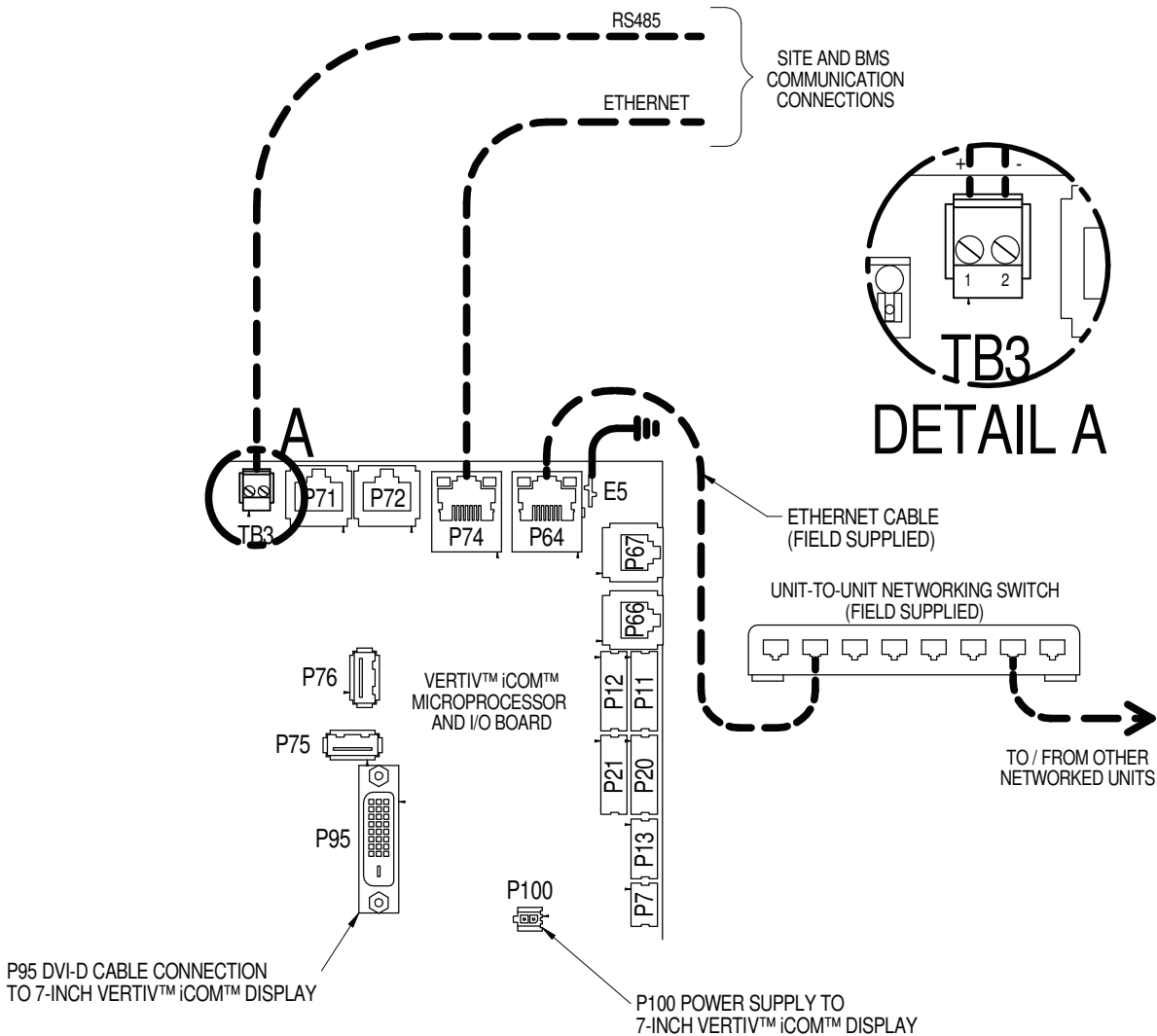

UNIT TO UNIT NETWORK CONNECTIONS FOR CoolPhase Perimeter, CoolLoop Perimeter and CoolLoop Thermal Wall

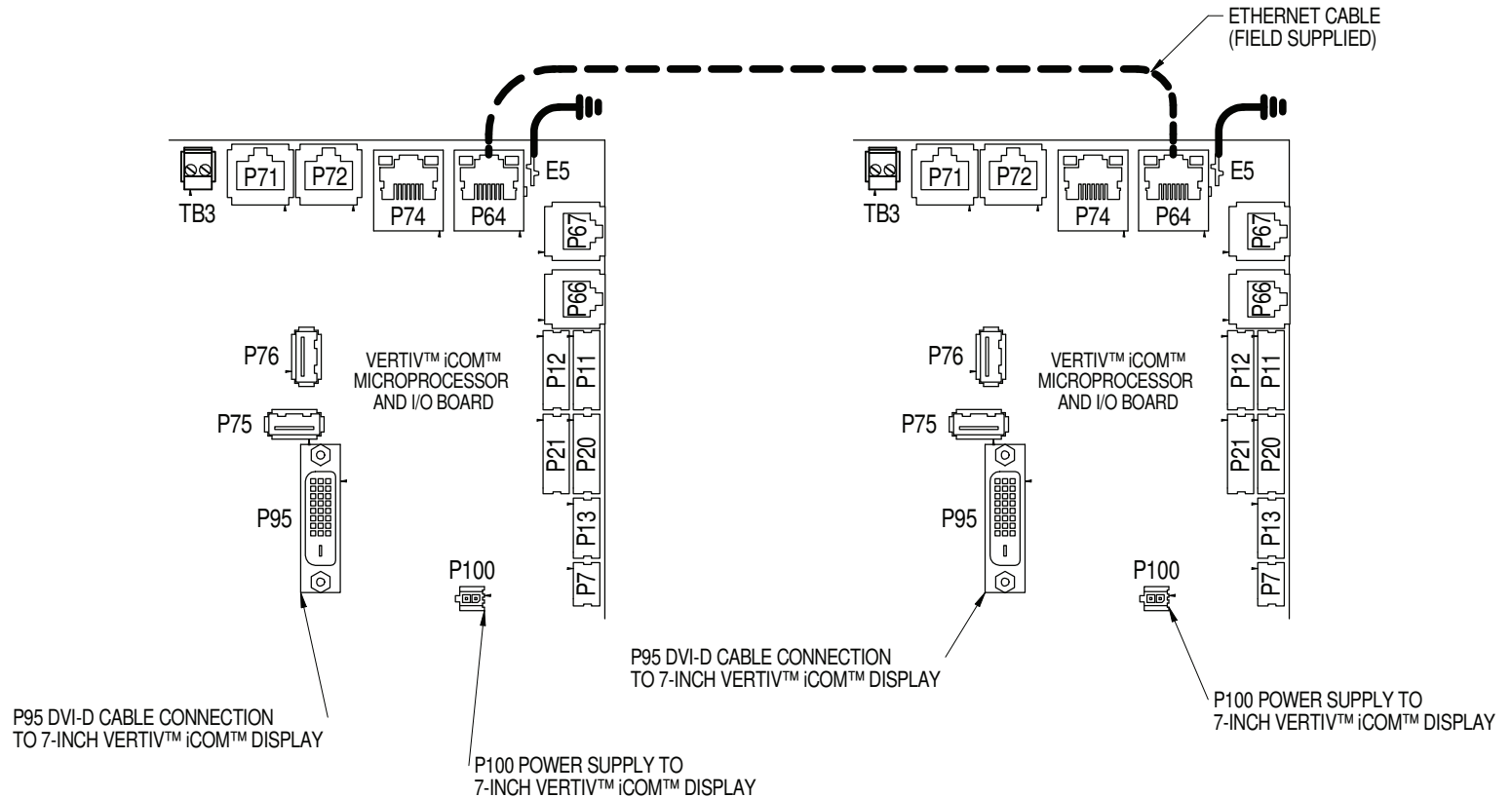

NOTE* For dual-unit network configurations only

2T RACK TEMPERATURE SENSOR CONNECTIONS FOR CoolPhase Perimeter, CoolLoop Perimeter and CoolLoop Thermal Wall

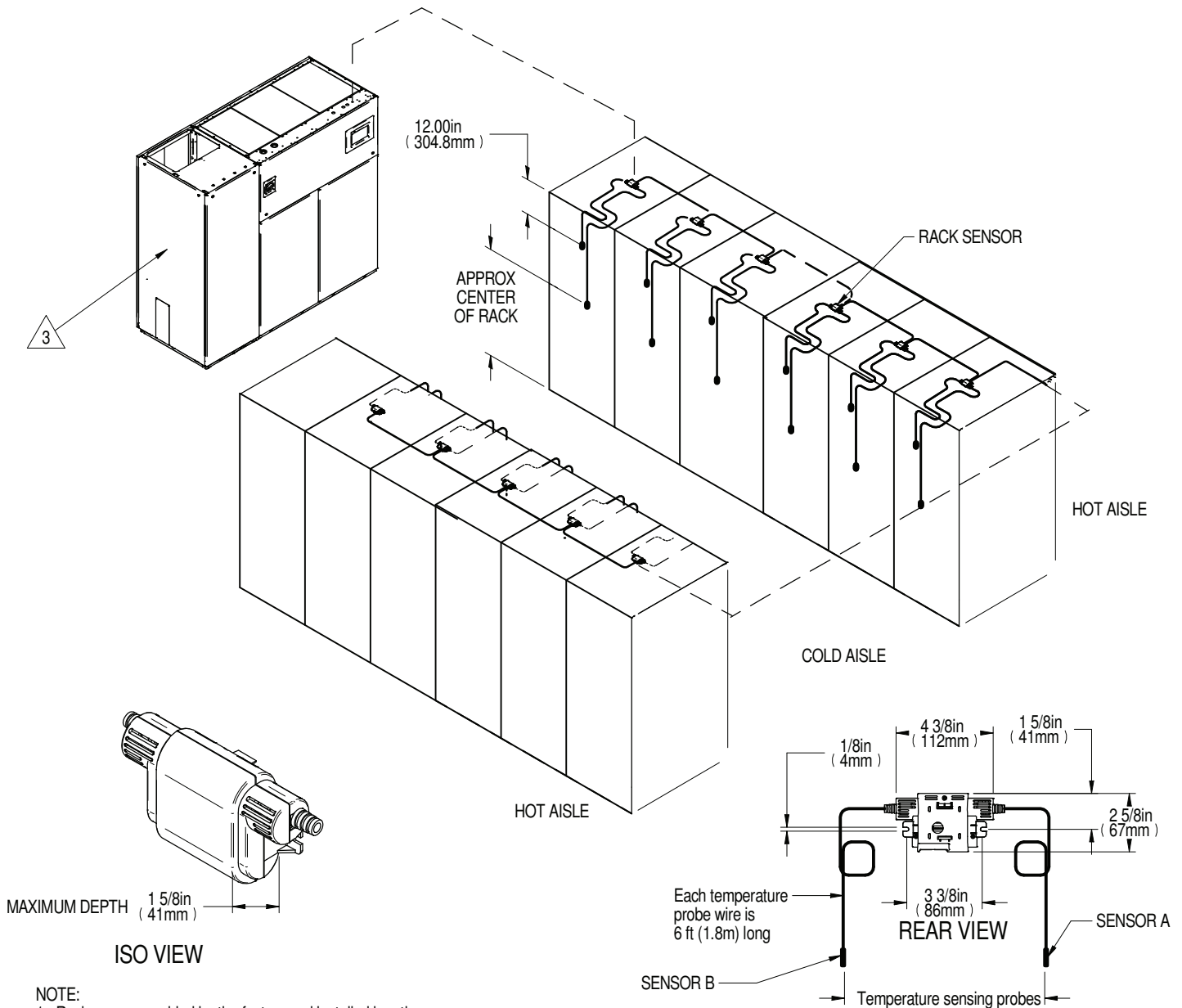

NOTE:

1. Rack sensor provided by the factory and installed by others.
2. Install temperature sensors on the perforated portion of the rack door using the supplied wire ties. Ensure door can swing open freely without binding cables.
3. The cooling unit used in this submittal drawing is a reference model, it's only purpose is to show how a 2T sensor system can be laid out.
4. The low voltage electrical knockout locations will vary between Vertiv™ units.
5. All the low voltage internal component orientations and positioning will vary.

RECOMMENDED WIRED SENSOR LOCATIONS

1. Racks at end of aisles/rows shall be monitored via wired/wireless temperature sensors.
2. At minimum 1 of every 3 racks should be monitored, equally spaced if populated racks exist.

SEE INSTRUCTION SHEET 310301 FOR CANBUS WIRE CONSIDERATIONS AND SENSOR INSTALLATION INSTRUCTIONS.

REMOTE TEMPERATURE & HUMIDITY SENSOR

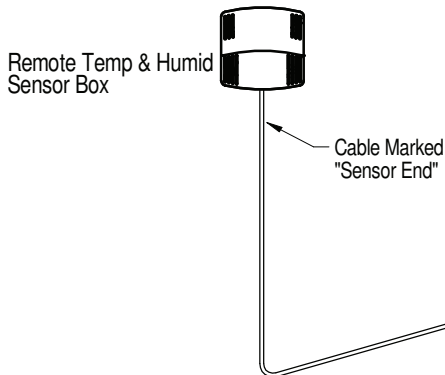
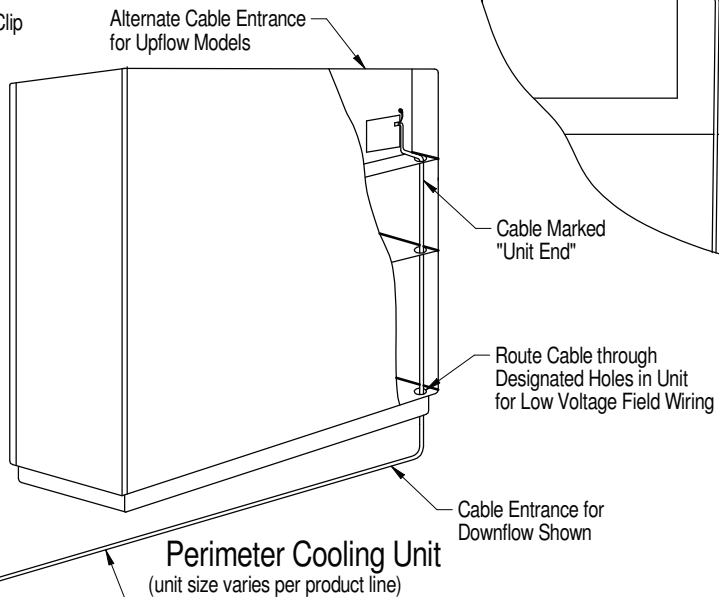
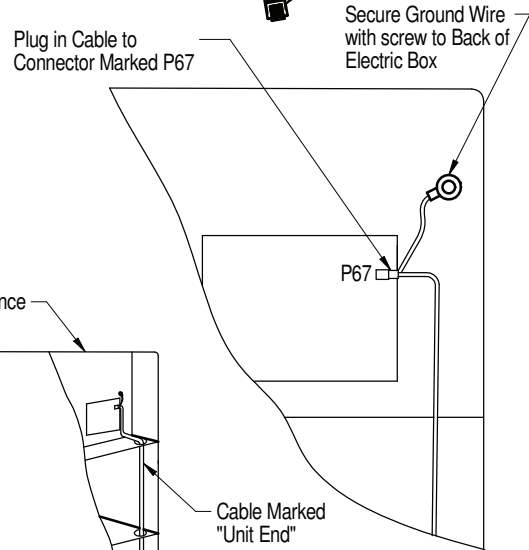
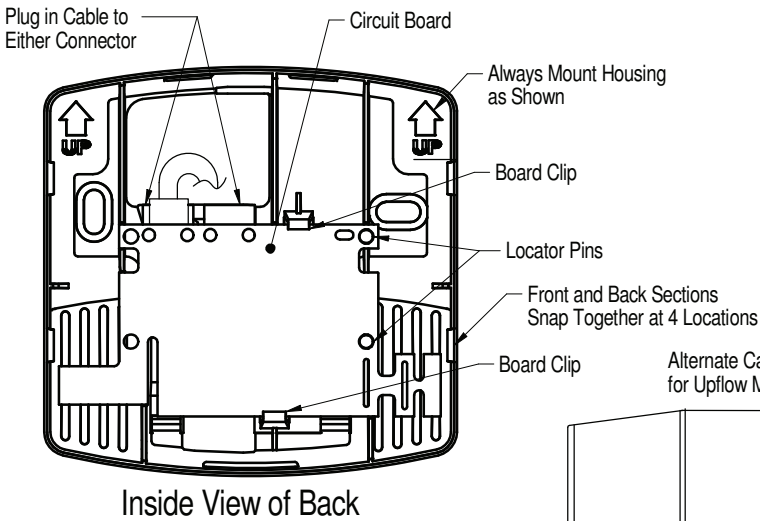
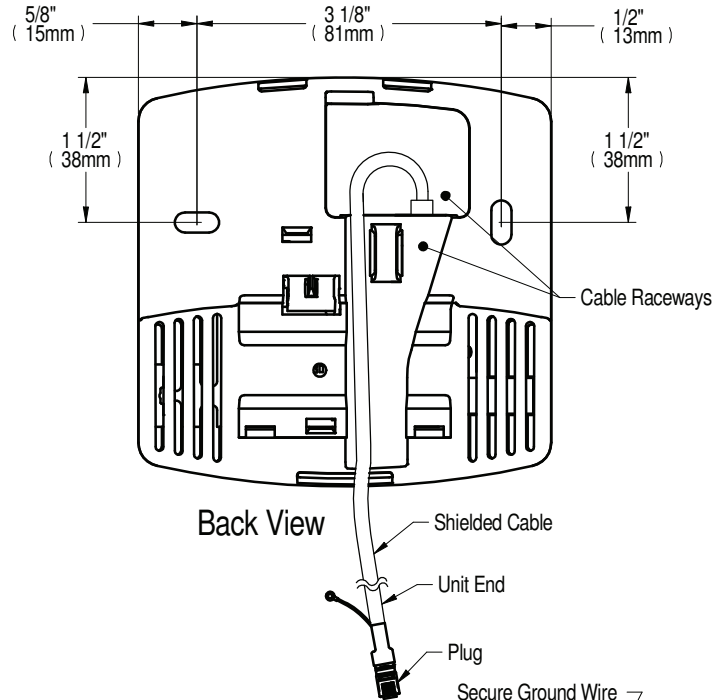
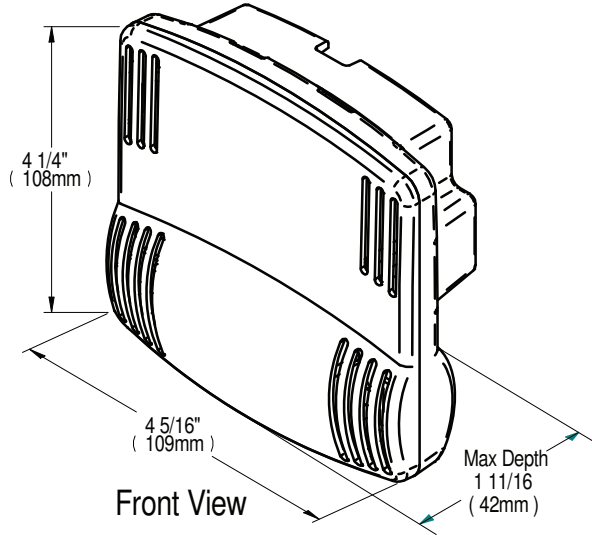

Factory supplied, field installed shielded cable. See specification sheet for length.

CoolLoop Thermal Wall

CA60 PRIMARY CONNECTION LOCATIONS WITH BRAZED CUSTOMER CONNECTIONS

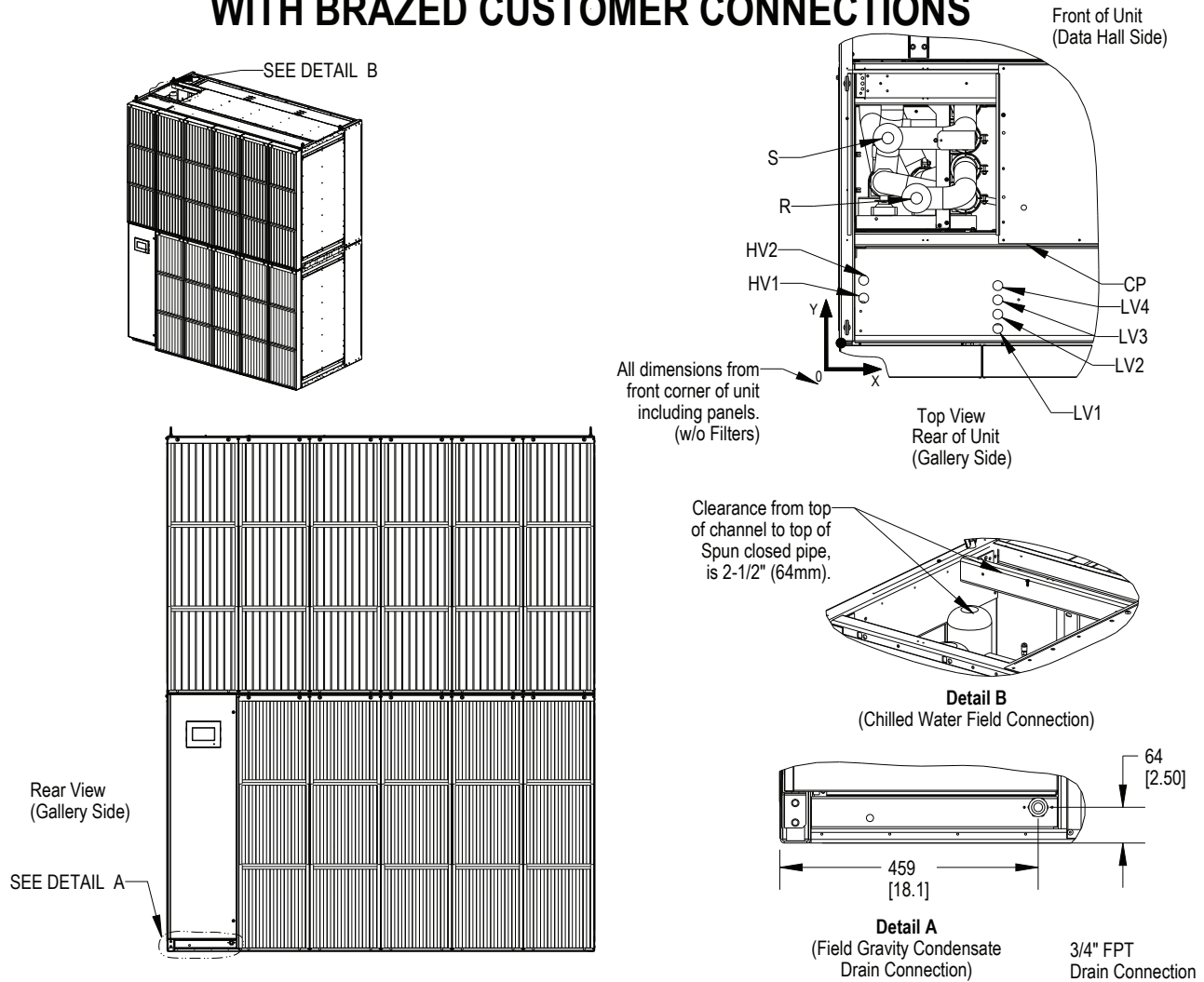

Connection	Description	X mm (in.)	Y mm (in.)	Connection Size Opening in.
R	Return Pipe Connection	274 (10.8)	513 (20.2)	4" O.D. CU
S	Supply Pipe Connection	173 (6.8)	726 (28.6)	
LV1	Electrical Connection (Low Volt)	564 (22.2)	51 (2.0)	1-3/8
LV2			102 (4.0)	
LV3			152 (6.0)	
LV4			203 (8.0)	
HV1	Electrical Connection (High Volt)	86 (3.4)	157 (6.2)	1/2" O.D. CU
HV2			221 (8.7)	
CP	Condensate Pump Connection	655 (25.8)	480 (18.9)	

Notes:

1. Drawing not to scale. All dimensions from left corner on Gallery Side and have a tolerance of $\pm 1/2"$ (13mm).
2. The factory unit does not contain a trap. The drain must comply with all local codes. Select appropriate drain system materials. Field pitch Condensate Drain line a minimum 1/8" (3mm) per 12" (305mm).
3. Piping connection can be made at the top of the unit.

CA60 PRIMARY CONNECTION LOCATIONS WITH BRAZED CUSTOMER CONNECTIONS CHILLED WATER COIL DRAIN DETAIL

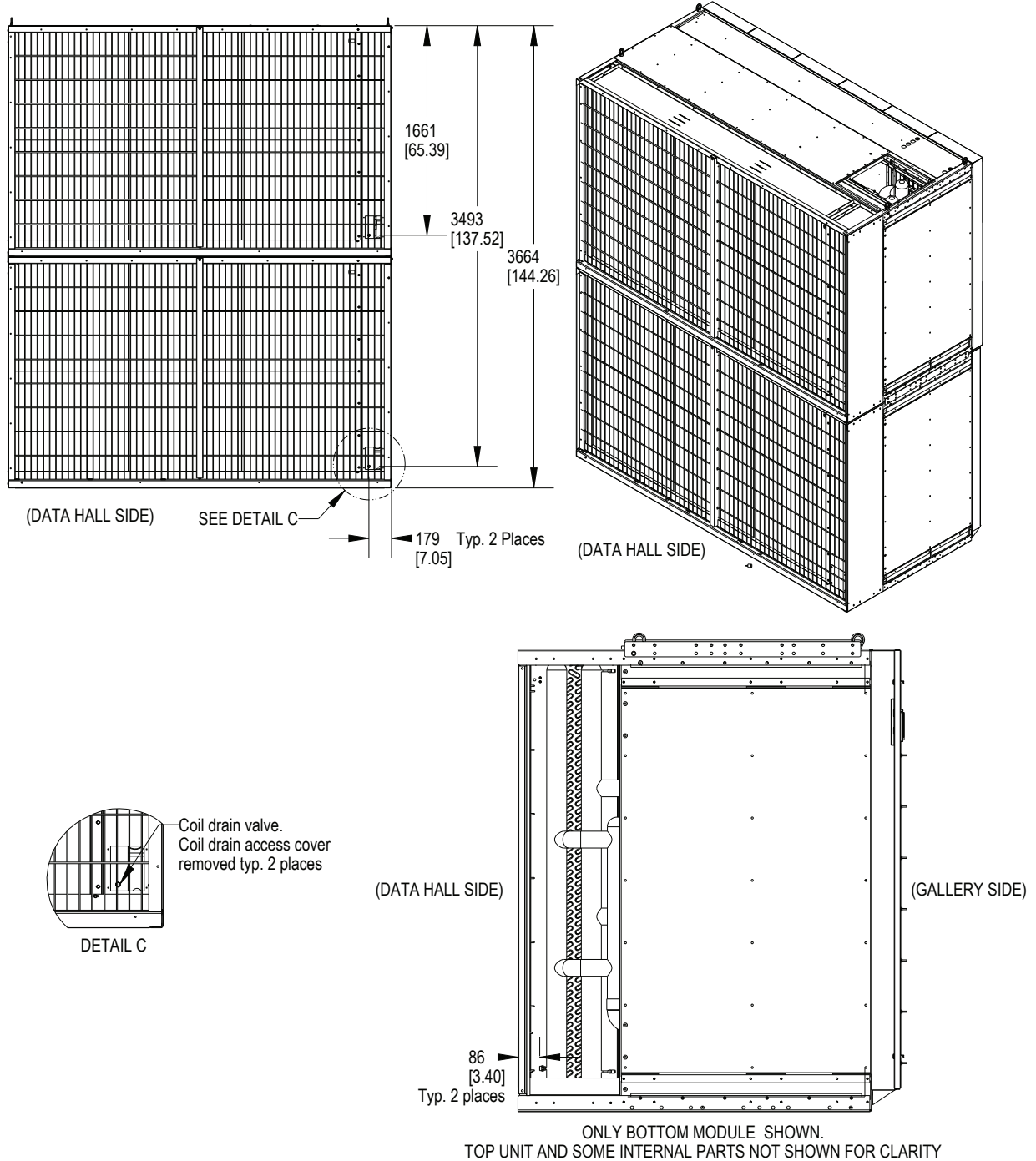

Notes:

1. Drawing not to scale.

CA60 TOP AND BOTTOM ASSEMBLY INTERNAL CONDENSATE DRAIN LINE CONNECTION

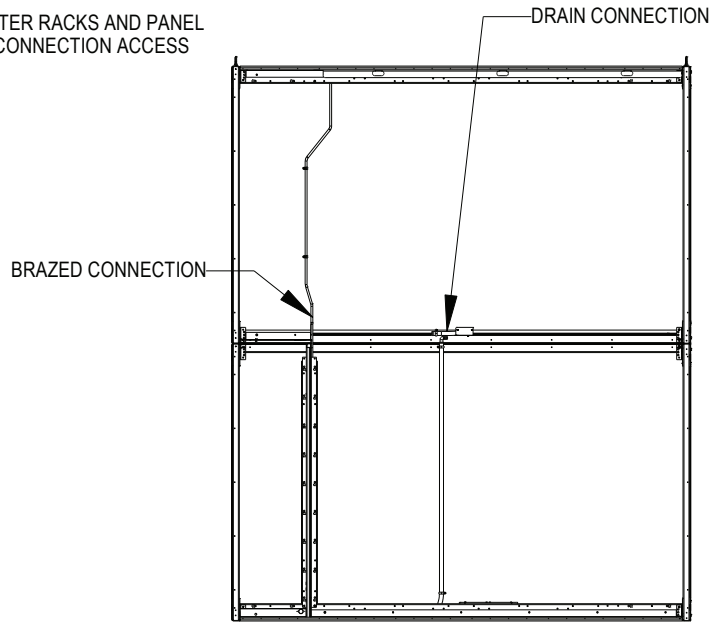
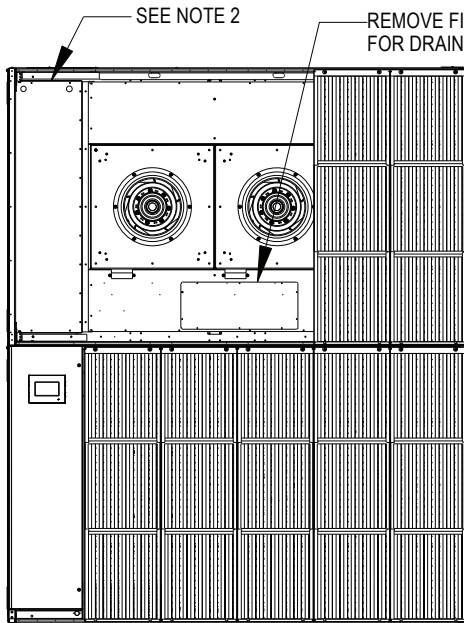

DRAIN LINE ROUTING
FRAME SHOWN FOR REFERENCE. SOME MEMBERS HIDDEN FOR CLARITY

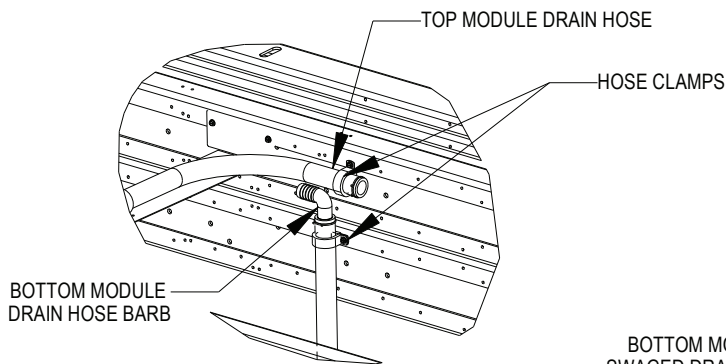

INTERNAL DRAIN CONNECTION
SEE NOTE 1 FOR DRAIN CONNECTION DETAILS

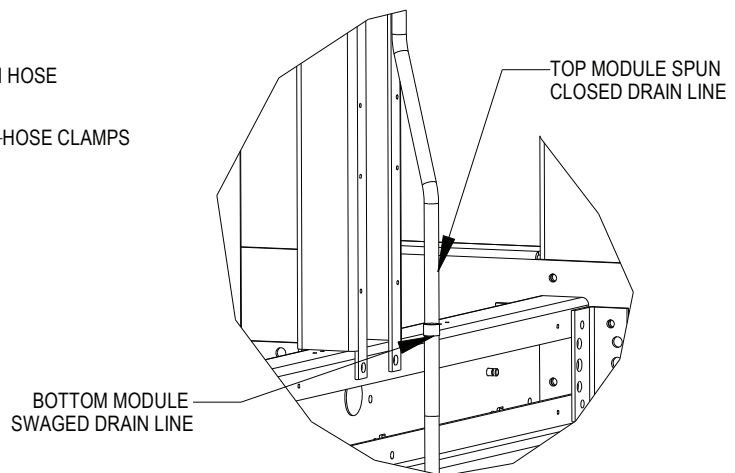

INTERNAL BRAZED CONNECTION FOR CONDENSATE PUMPS
SEE NOTE 3 FOR DRAIN CONNECTION DETAILS

NOTES:

1. REQUIRED FOR GRAVITY DRAIN AND CONDENSATE PUMP. INTERNAL CONNECTION MUST BE MADE BETWEEN TOP AND BOTTOM DRAIN HOSES. CUT HOSE TO LENGTH ON TOP MODULE AND ADJUST HOSE CLAMPS TO ENSURE PROPER SLOPE FOR DRAINAGE.
2. FOR CONDENSATE PUMP ONLY. REMOVE PANEL TO ACCESS BRAZED COPPER DRAIN CONNECTION.
3. REMOVE EXCESS COPPER ON SPUN CLOSED TOP MODULE DRAIN LINE. REMOVE PLUG ON BOTTOM MODULE COPPER DRAIN LINE. ENSURE COPPER IS CLEAN BEFORE BRAZING INTERNAL CONNECTION.



CoolLoop Thermal Wall

SUBTL CA60 EXT GRAVITY DRAIN

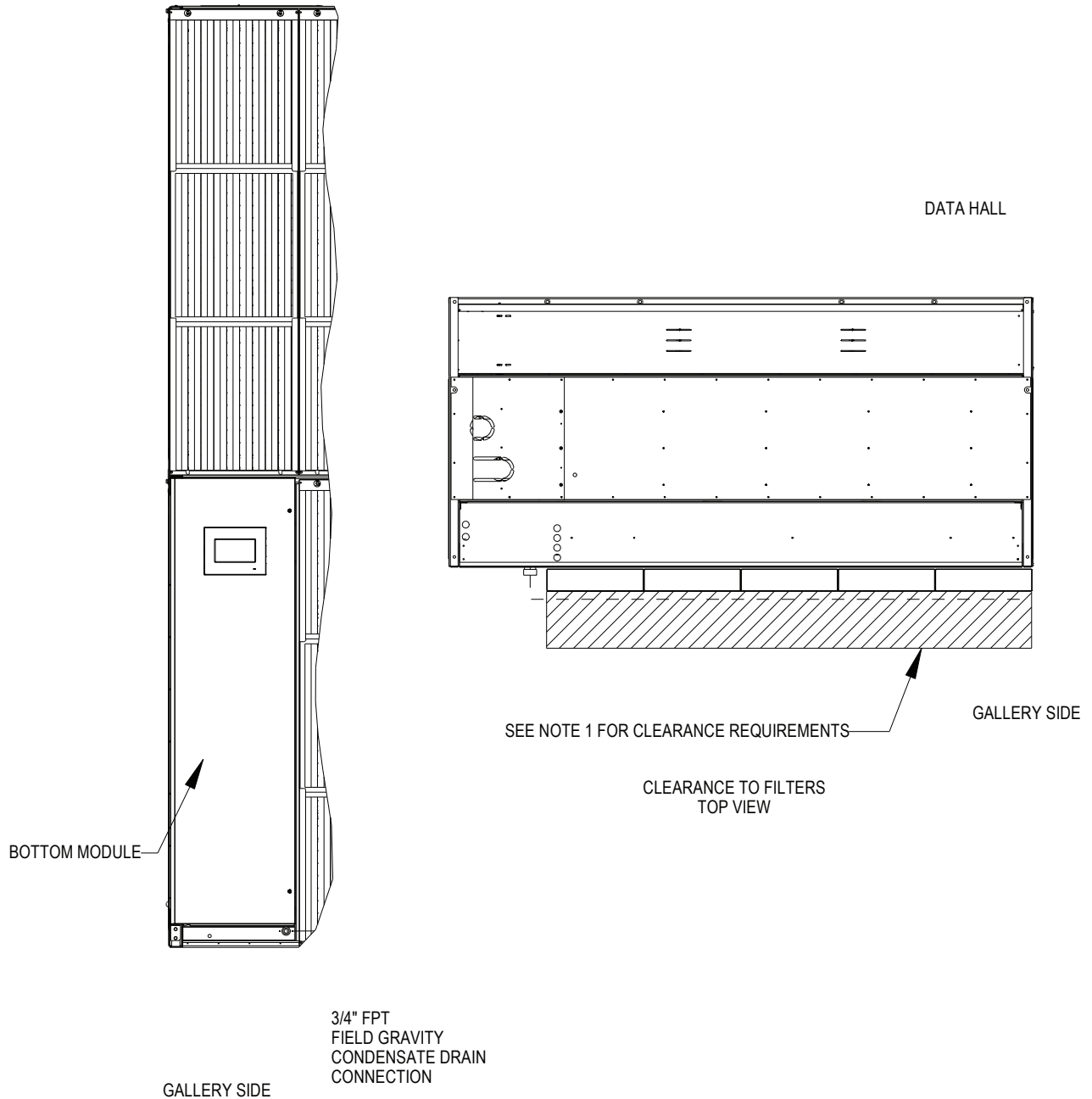

NOTES:

1.FOR EXTERNAL DRAIN CONNECTION ROUTED IN FRONT OF FILTERS, 101.6 [4.00"] MINIMUM CLEARANCE REQUIRED.



CoolLoop Thermal Wall

CA60 BACKDRAFT BARRIER PLATE KIT High Airflow/High Efficiency Fan

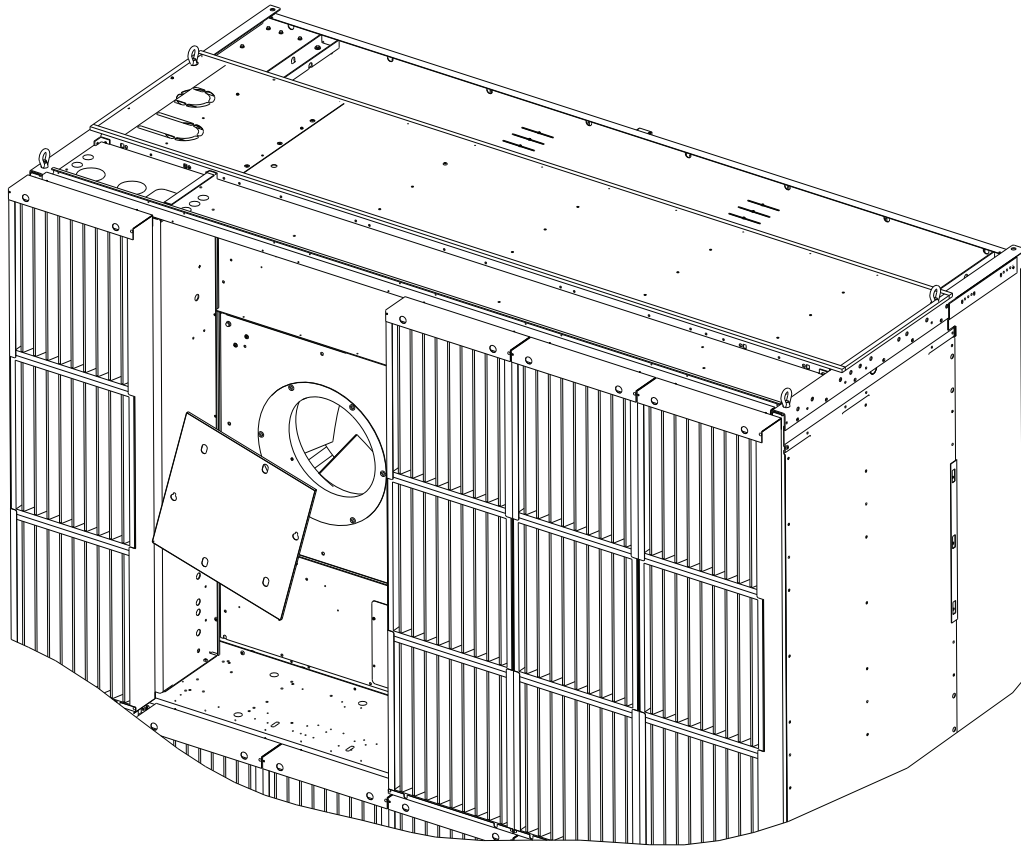

- Notes: 1. Backdraft Barrier Plate Kit for the High Airflow/High Efficiency fans shall be used to block airflow for unit or fan not in operation. Kit includes three plates
Multiple quantities may be ordered per desired application.
2. A Backdraft Barrier Plate Kit also exists for the High Airflow, or High Airflow/High Static fan option which utilizes a similar blocker plate design with some dimensional variance.

CoolLoop Thermal Wall

CA80 COMPONENT LOCATION DIAGRAM

1. Chilled Water Coil (Typ. 2)
2. Fans (Qty. 8)
3. Air Filters (Typ. 45, Optional)
4. Electric Panel (behind the door)
5. Condensate Drain
6. Condensate Pump (Optional, located behind filters & fans)
7. Chilled Water Connection Location
8. High Voltage Electrical Knockout
9. Filter Clog Switch (Supplied with optional filters)
10. Liqui-Tect Sensor (Optional, located behind filters)
11. Smoke Detector (Located behind air filter)
12. Discharge Grill
13. Discharge Damper (Optional, replaces discharge grill)
14. Coil Drain Plug (Typ. 2, lower right corner of top and bottom modules)
15. Coil Air Vent Plug (Typ. 2, upper right corner of top and bottom modules)
16. Chilled Water Valves (Located behind closing panel)
17. Water Valves Inspection Window

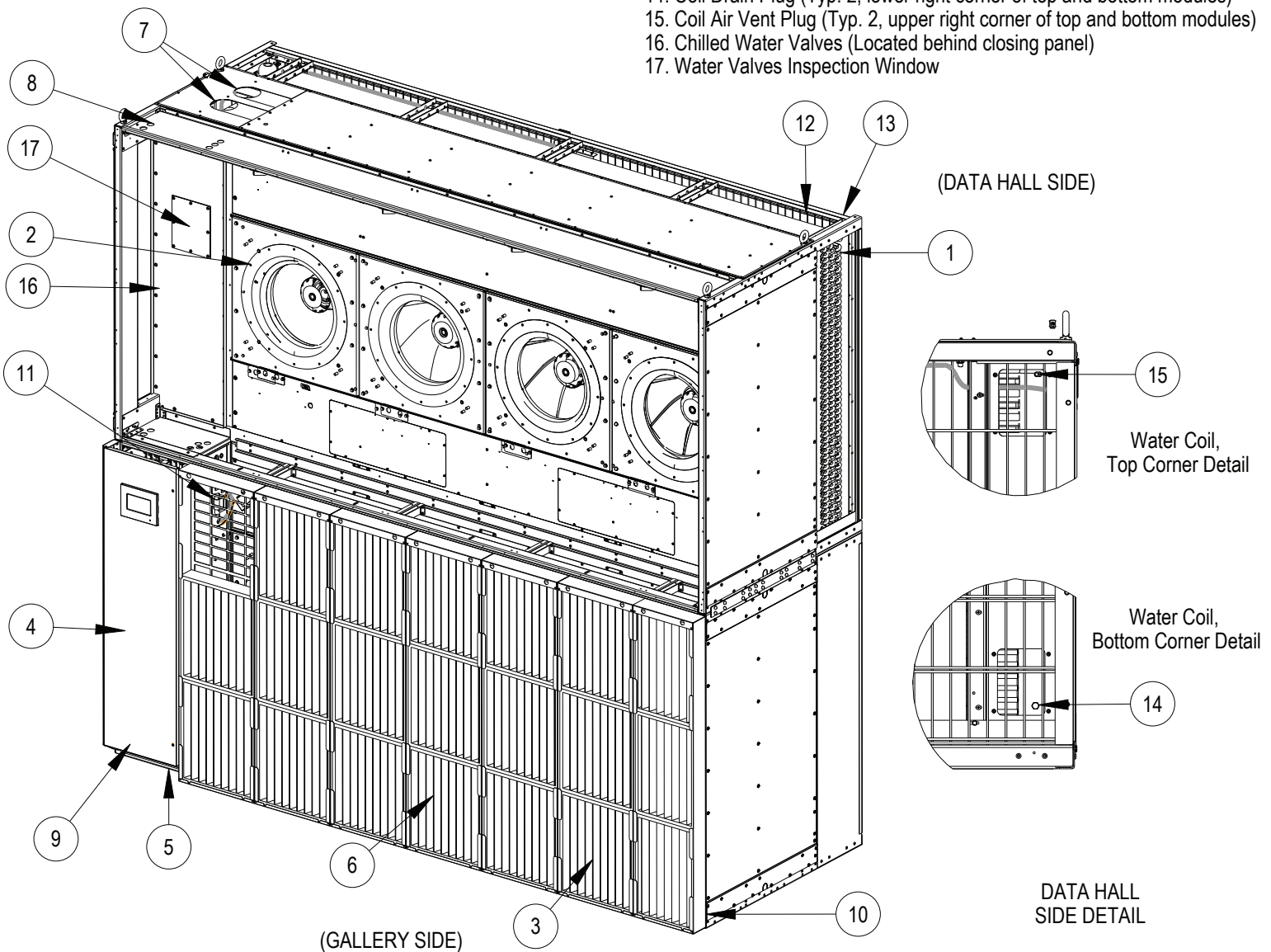

Note: Some items not shown for clarity

CoolLoop Thermal Wall

CABINET & ANCHOR DIMENSIONAL DATA CA80 BOTTOM AND TOP MODULES

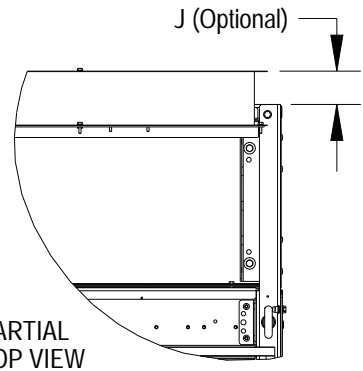
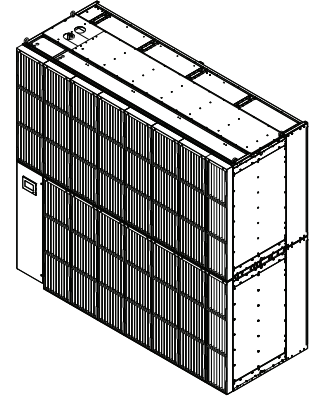
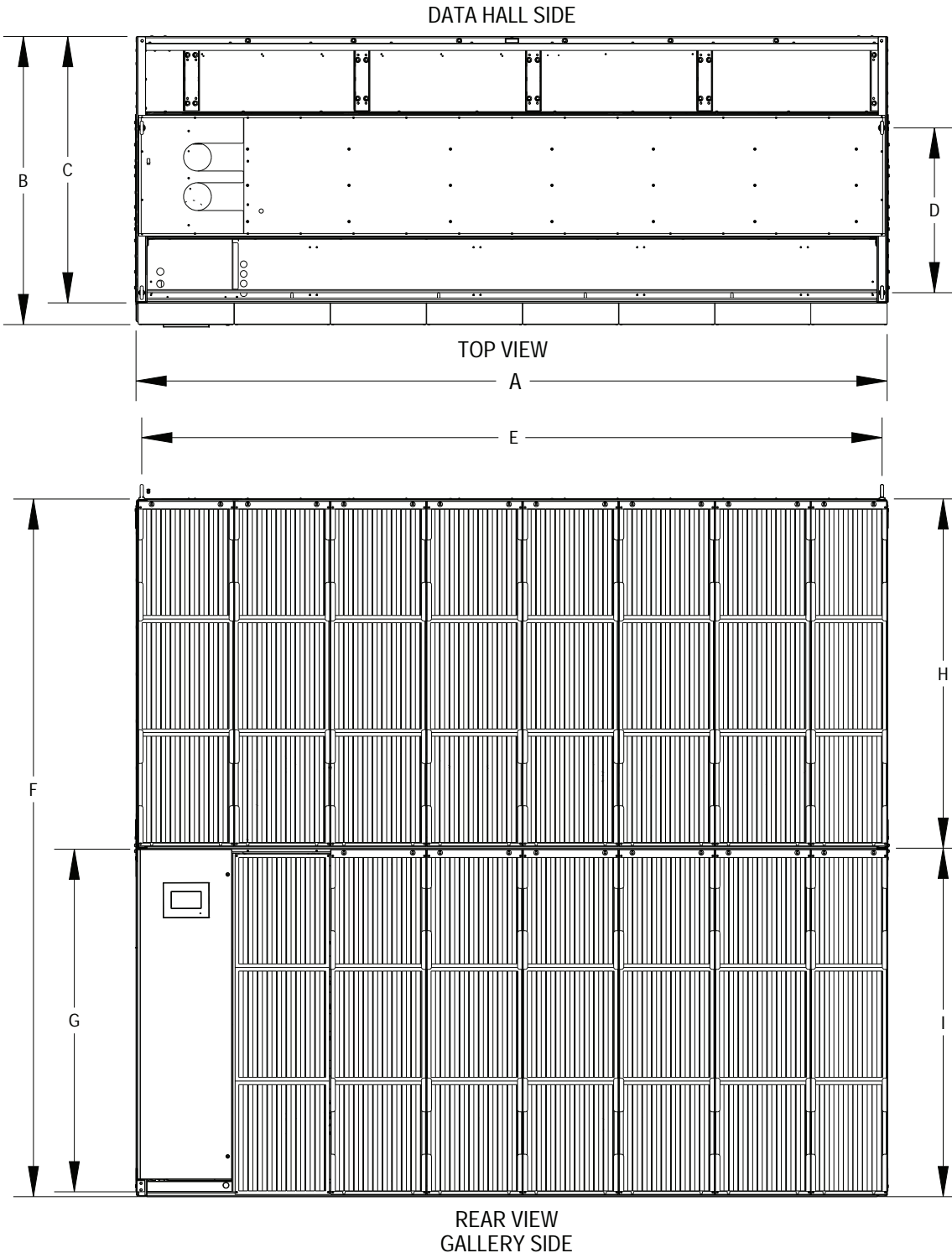

Note: Additional depth with optional damper kit installed on gallery side.

	Dimensional Data in. (mm)
A	155.5 (3949)
B	60.0 (1524)
C	55.1 (1400)
D	34.1 (867)
E	153.2 (3892)
F	144.3 (3664)
G	70.0 (1778)
H	72.2 (1834)
I	72.1 (1832)
J (opt.)	2.9 (73)

- Notes:
1. Some parts hidden for clarity.
 2. Filters are accessible on the gallery side
 3. All dimensions are in in. (mm).

CABINET & ANCHOR DIMENSIONAL DATA CA80 BOTTOM AND TOP MODULES

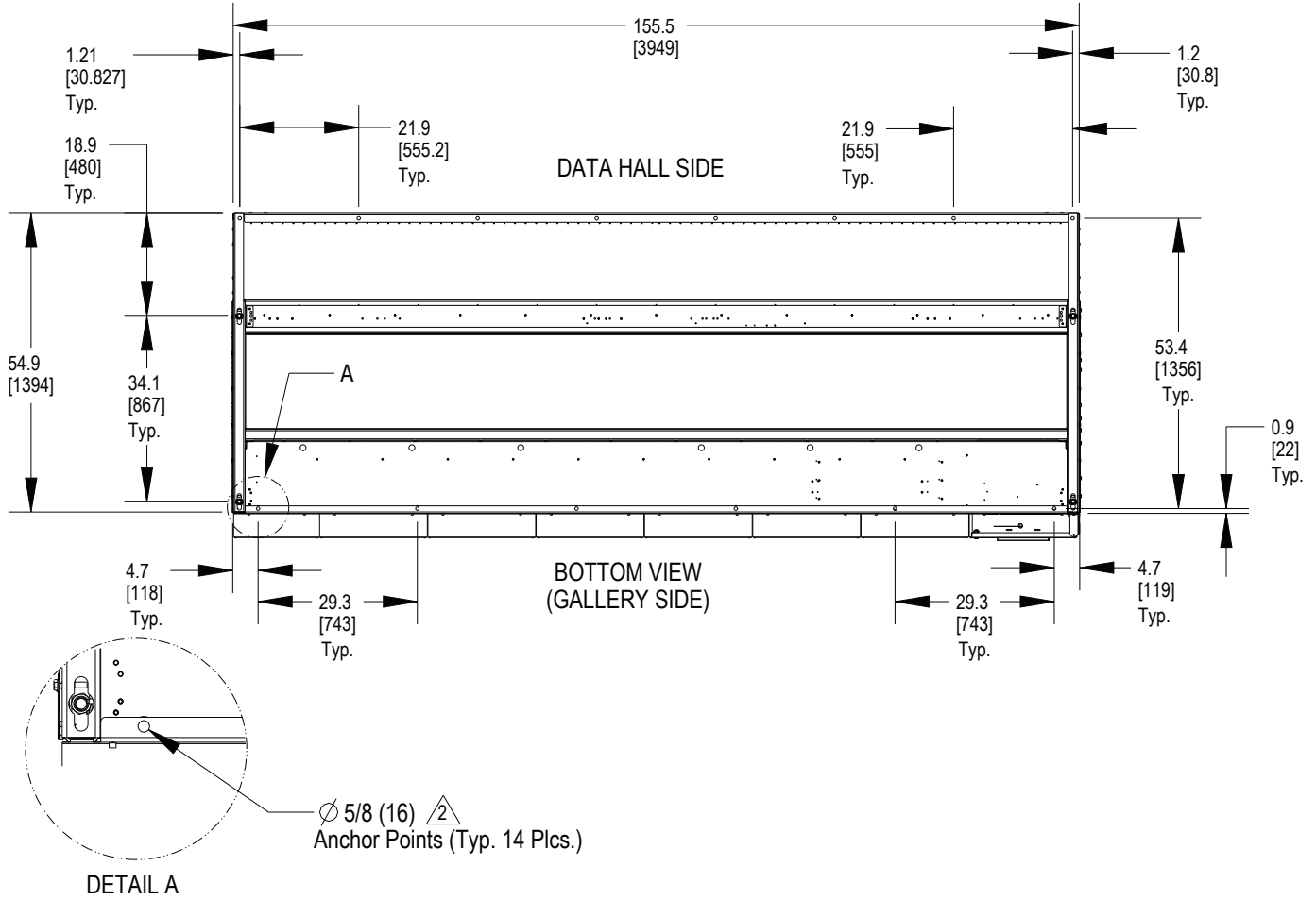

\triangle UNIT WEIGHTS

	Module Dry Weight lbs. (kg)	Operating Weight lbs. (kg)	Module Domestic Pack lbs. (kg)	Module Export Pack lbs. (kg)
Top Module	3980 (1805)	4333 (1965)	4467 (2026)	4540 (2059)
Bottom Module	3780 (1714)	4133 (1874)	4266 (1935)	4339 (1968)

PACKAGING DIMENSIONS

	Domestic Pack Dimensions L x W x H in.(mm)	Export Pack Dimensions L x W x H in.(mm)
Top Module	162 x 70 x 87 (4115 x 1778 x 2210)	162 x 70 x 87 (4115 x 1778 x 2210)
Bottom Module	162 x 70 x 91 (4115 x 1778 x 2312)	162 x 70 x 91 (4115 x 1778 x 2312)

Notes:

1. Some parts hidden for clarity.

\triangle Fourteen (14) floor mounting holes and (14) 1/2" field supplied bolts required to secure unit base to customer support structure. Bolt grade to be specified by local requirements.

\triangle Weights reflect heaviest configuration.

4. Weights and dimensions exclude dampers, which are shipped loose and installed on-site. Each module requires two dampers (with a weight of 44 kg each damper).

CA80 INSTALLATION AND SERVICE CLEARANCE

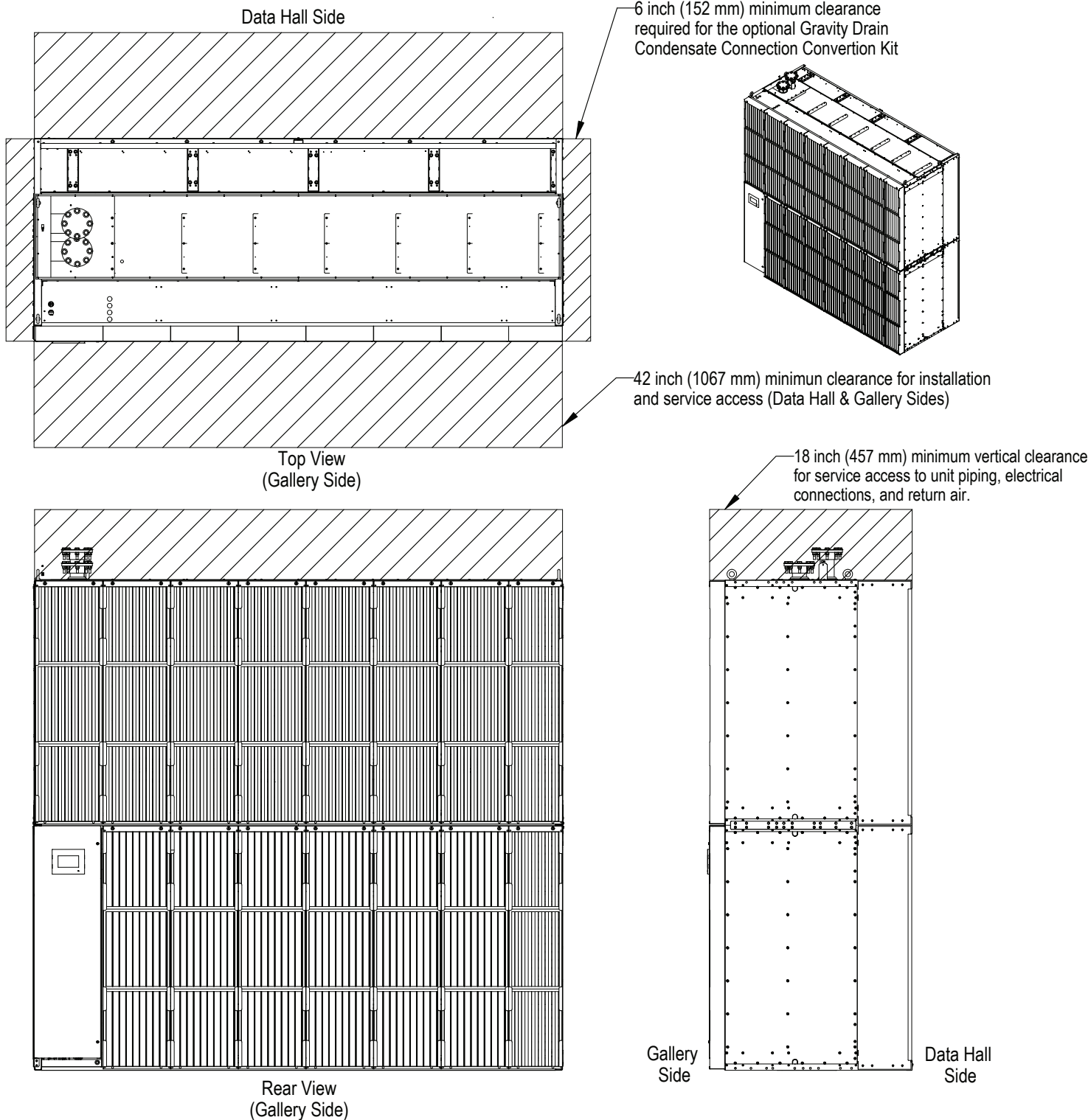

-The service clearance are intended for regular maintenance operation (e.g., air filters, fans, valve actuators, electrical panel, dampers, etc.) to allow safe operations.

-For extraordinary maintenance, additional service clearance on the sides of the units would help to reduce the maintenance time.

-The dampers and the dampers actuators are accessible only on Data Hall Side (only when damper option is selected).



CoolLoop Thermal Wall

CA80 FLOOR PLANNING FOR ADJACENT UNITS

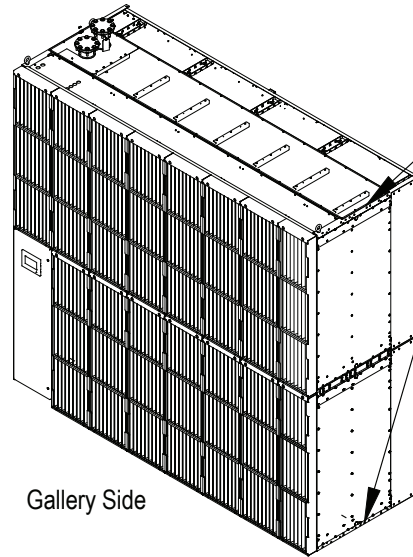

Apply minimum 0.75 in [19mm] gasketing to horizontal and vertical frame members at top, bottom, gallery side and data hall side of stacked unit. Do not apply gasketing to filter assemblies. Type and method of gasketing to be provided and applied by others in the field.

Data Hall Side

Gallery Side

Data Hall Side

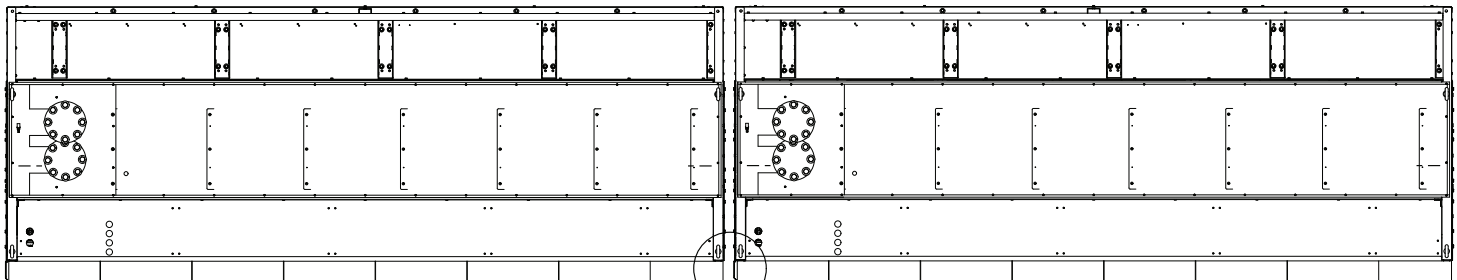

SEE DETAIL A

Gallery Side

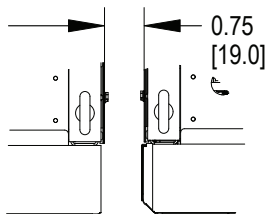

DETAIL A



Minimum Gap to be filled with gasketing between units that do not have the gravity condensate connection conversion kit. Apply 6 in [152 mm] of side clearance when a gravity condensate connection conversion kit is installed.

Notes:



Gap is measured between frame members of adjacent units.

CoolLoop Thermal Wall

CA80 AIRFLOW SCHEMATIC

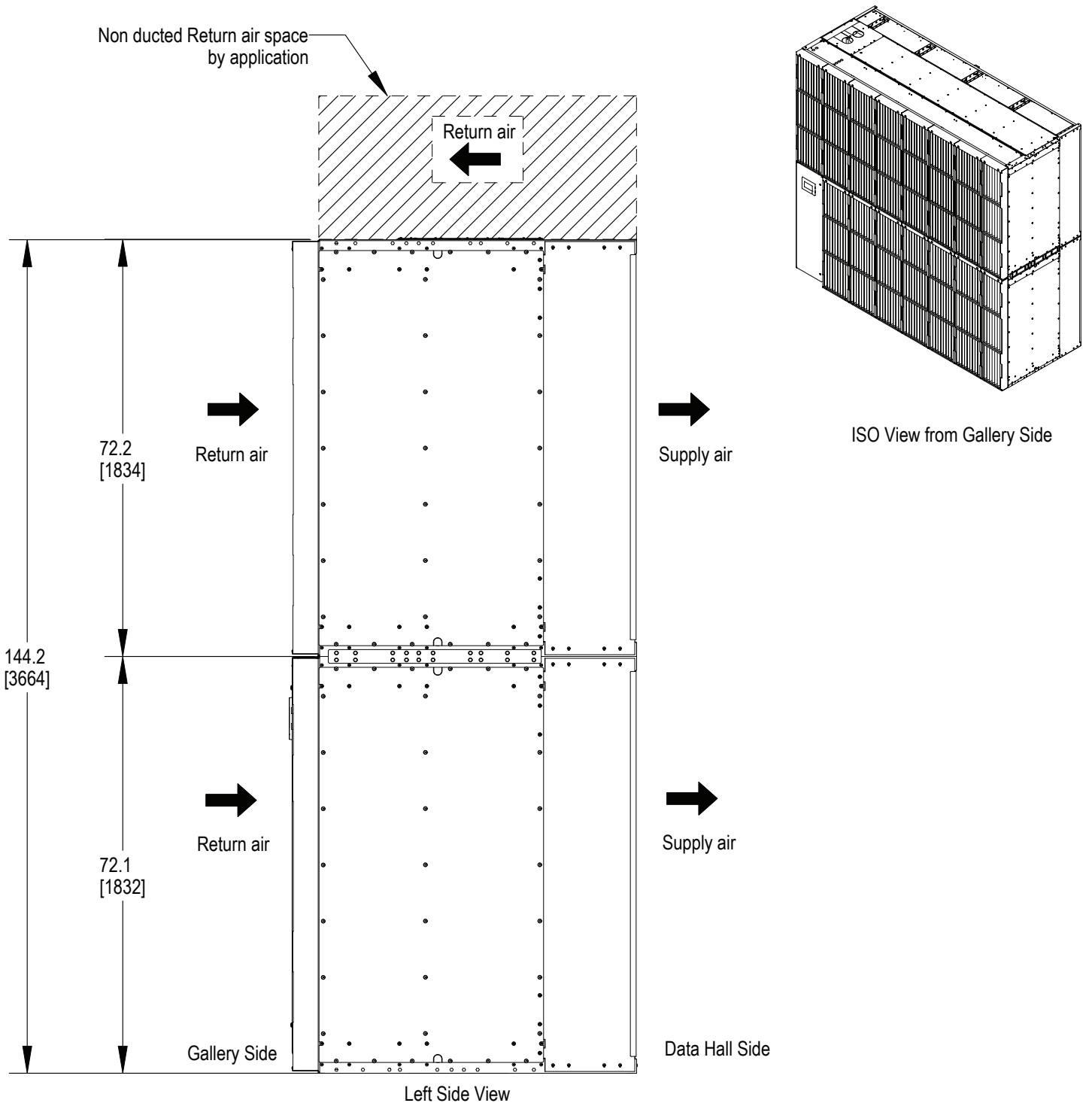

CoolLoop Thermal Wall

CA80 GENERAL ARRANGEMENT DIAGRAM 2-WAY MOTORIZED VALVE

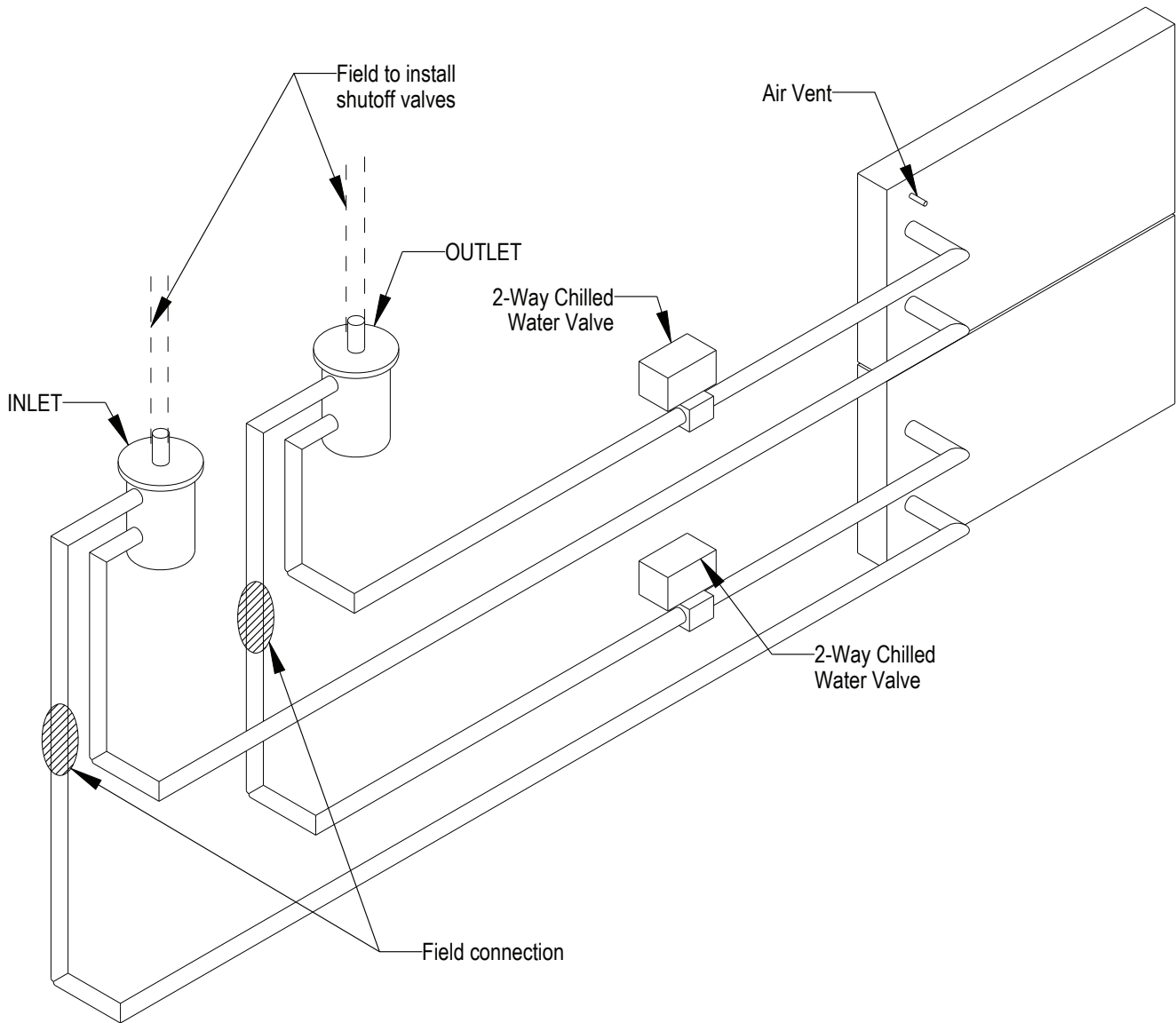

Note:
1) Components are not supplied by Liebert, but are required for proper circuit operation and maintenance

----- FIELD PIPING
 ----- FACTORY PIPING

CoolLoop Thermal Wall

CA80 GENERAL ARRANGEMENT DIAGRAM 2-WAY PRESSURE INDEPENDENT MOTORIZED VALVE

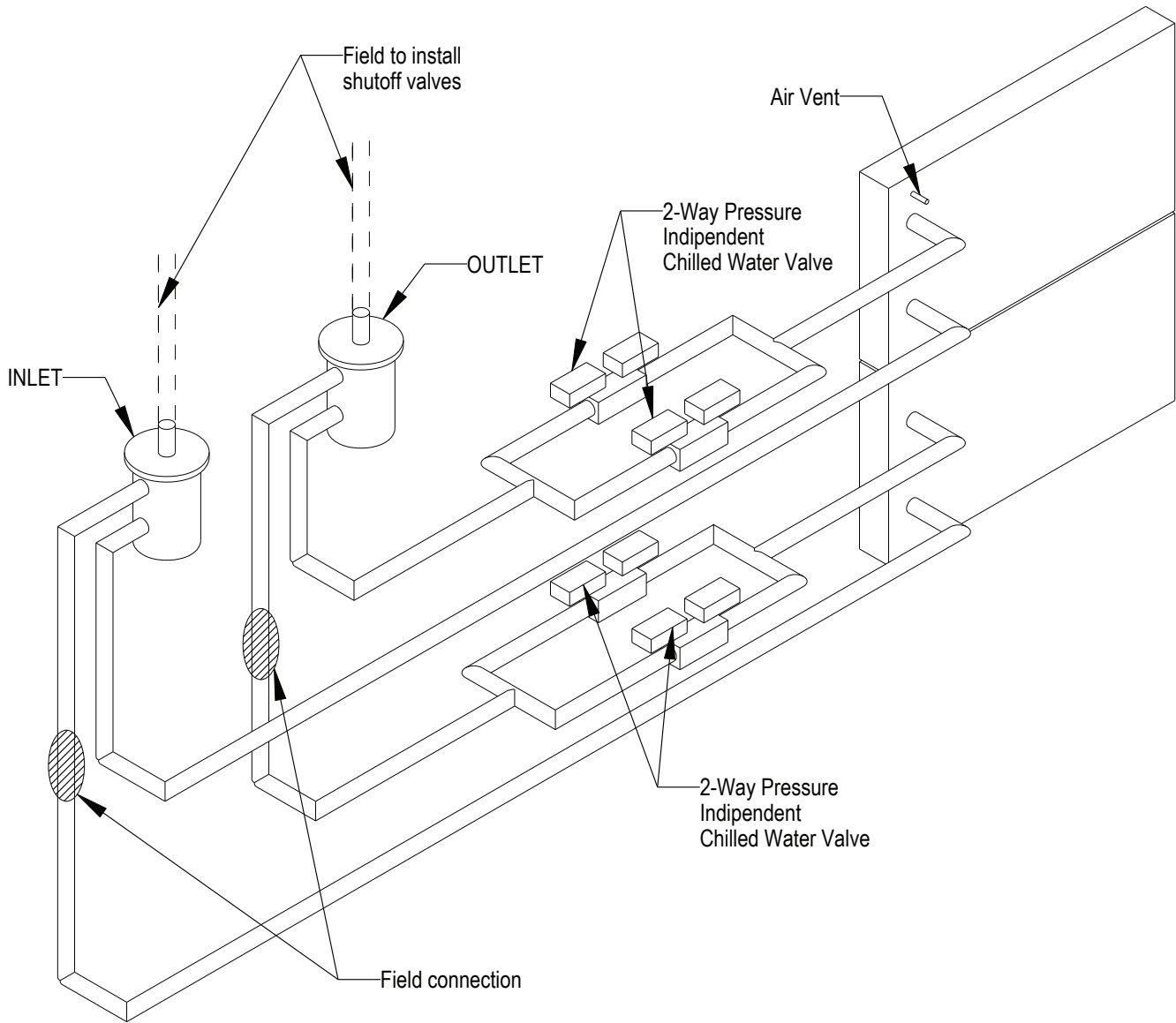

Note:
1) Components are not supplied by Liebert, but are required for proper circuit operation and maintenance

----- FIELD PIPING
 _____ FACTORY PIPING



CoolLoop Thermal Wall

CA80 SEISMIC APPLICATION ASSUMPTIONS AND REQUIREMENTS

Vertiv has conducted analytical modeling of the Vertiv™ CoolLoop Thermal Wall product to provide an option for those systems requiring seismic certification of compliance. This certification goes beyond the equipment's ability to withstand the seismic forces: the IBC (International Building Code) and ASCE (American Society of Civil Engineers) system approach includes the equipment, equipment anchorage, and the connections to the equipment [power, piping, and ducting].

Certification Criteria

The Vertiv™ CoolLoop Thermal Wall certification is based on a maximum mapped, maximum considered earthquake spectral response acceleration value, S_s , of 1.125g adjusted by the soil site coefficient to Soil Site Class D as the default when the site soil properties or final equipment installation location is not known. The certification maximum spectral response coefficient is S_{ds} value of .75g including Soil Class and Seismic Use group corrections. Soil Classes A, B, C, D, and E, and Seismic Design Categories A, B, C, D, E, and F are all covered under this certification, limited by the S_{ds} value stated above. Structural analysis has been conducted to demonstrate that the equipment meets performance objectives required for a component importance factor (I_p) of 1.0. Specifically, structural integrity is demonstrated such as to not pose a life safety hazard. A Vertiv™ CoolLoop Thermal Wall, as described above, is approved for seismic application as a system when properly installed in the following configurations:

- Vertiv™ CoolLoop Thermal Wall unit, with factory-installed seismic option, attached directly to a housekeeping pad using the anchoring system defined in this document.
- The certification excludes all non-Vertiv supplied accessories, including but not limited to floor stands, and isolators.

Certification	IBC	
Internal Bracing Option	Factory installed	
Unit	S_{ds}	I_p
CA80 (Top and Bottom Module)	.75	1.0

CA80 SEISMIC APPLICATION ASSUMPTIONS AND REQUIREMENTS

Requirements for Anchorage

Anchors

1. Mounting requirement details such as brand, type, embedment depth, edge spacing, anchor spacing, concrete strength, wall bracing, and special inspection must be outlined and approved by the project Structural Engineer of Record.

Anchorage Surface

2. Structural floors and housekeeping pads must also be seismically designed and approved by the project Structural Engineer of Record to withstand the seismic anchor loads as defined on the installation drawings. The installing contractor is responsible for the proper installation of all anchors and mounting hardware, observing the mounting requirement details outlined by the Engineer of Record. Contact the Manufacturer's Representative if a detailed Seismic Installation Calculation Package is required.

Unit Field Connections

3. Piping Field Connections: All units, either rigidly mounted or mounted on vibration isolators, shall be attached to the piping system using flexible loops designed for seismic movement. Flexible loops shall be capable of movement in the three axes and must completely isolate the equipment from the piping. The loops shall be suitable for an operating pressure and temperature of the system, refer to Vertiv installation instructions. This includes condensate drainage, and chilled water supply and return. Follow manufacturer's installation instructions for proper seismic application of flexible looping.

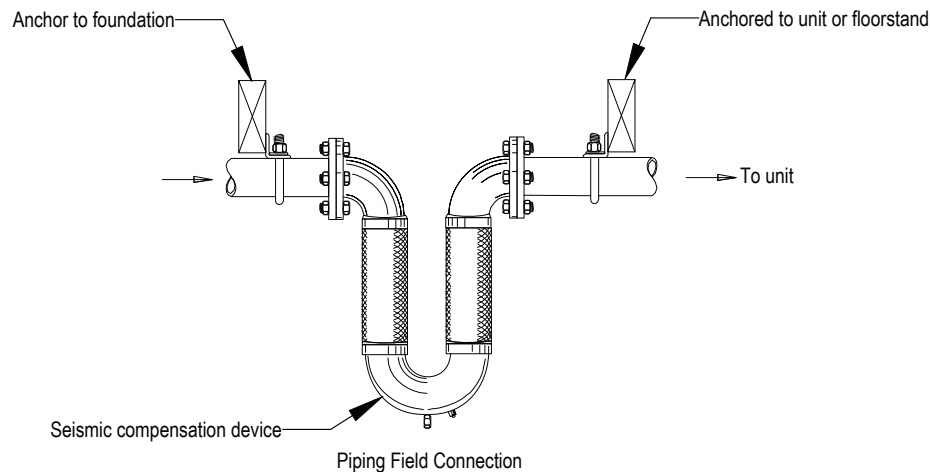

4. Electrical Connections: Must have adequate flexibility for seismic movement. Electrical wiring, conduit, and/or other connections to the equipment is the responsibility of others. Data and recommendations are supplied here and in the unit installation supplement for seismic installation.



CoolLoop Thermal Wall

CA80 DIMENSIONAL DATA SEISMIC MOUNTING (W/O ANCHOR BRACKETS)

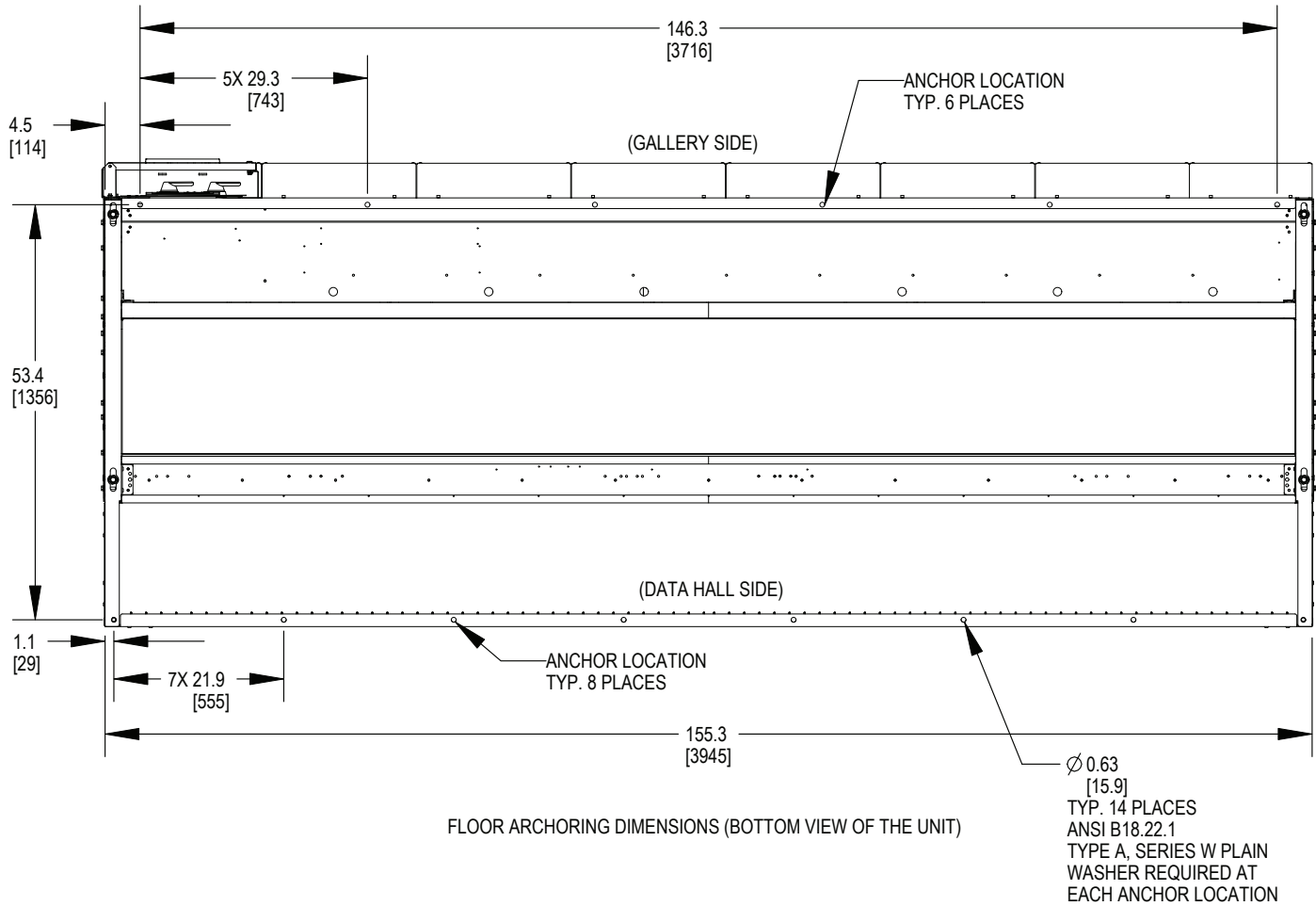

Notes:

1. Anchor Bolt sized per Engineer of Record.
2. Specified by Engineer of Record.



CoolLoop Thermal Wall

CA80 SEISMIC APPLICATION ASSUMPTIONS AND REQUIREMENTS

Vertiv has conducted analytical modeling of the Vertiv™ CoolLoop Thermal Wall product to provide an option for those systems requiring seismic certification of compliance. This certification goes beyond the equipment’s ability to withstand the seismic forces: the IBC (International Building Code) and ASCE (American Society of Civil Engineers) system approach includes the equipment, equipment anchorage, and the connections to the equipment [power, piping, and ducting].

Certification Criteria

The Vertiv™ CoolLoop Thermal Wall certification is based on a maximum mapped, maximum considered earthquake spectral response acceleration value, S_s , of 1.125g adjusted by the soil site coefficient to Soil Site Class D as the default when the site soil properties or final equipment installation location is not known. The certification maximum spectral response coefficient is S_{ds} value of 2.5g including Soil Class and Seismic Use group corrections. Soil Classes A, B, C, D, and E, and Seismic Design Categories A, B, C, D, E, and F are all covered under this certification, limited by the S_{ds} value stated above. Structural analysis has been conducted to demonstrate that the equipment meets performance objectives required for a component importance factor (I_p) of 1.0. Specifically, structural integrity is demonstrated such as to not pose a life safety hazard. A Vertiv™ CoolLoop Thermal Wall, as described above, is approved for seismic application as a system when properly installed in the following configurations:

- Vertiv™ CoolLoop Thermal Wall unit, with factory-installed seismic option, attached directly to a housekeeping pad using the anchoring system defined in this document.
- The certification excludes all non-Vertiv supplied accessories, including but not limited to floor stands, and isolators.

Certification	IBC	
Internal Bracing Option	Factory installed	
Unit	S_{ds}	I_p
CA80 (Top and Bottom Module)	2.5	1.0

CA80 SEISMIC APPLICATION ASSUMPTIONS AND REQUIREMENTS

Requirements for Anchorage

Anchors

1. Mounting requirement details such as brand, type, embedment depth, edge spacing, anchor spacing, concrete strength, wall bracing, and special inspection must be outlined and approved by the project Structural Engineer of Record.

Anchorage Surface

2. Structural floors and housekeeping pads must also be seismically designed and approved by the project Structural Engineer of Record to withstand the seismic anchor loads as defined on the installation drawings. The installing contractor is responsible for the proper installation of all anchors and mounting hardware, observing the mounting requirement details outlined by the Engineer of Record. Contact the Manufacturer's Representative if a detailed Seismic Installation Calculation Package is required.

Unit Field Connections

3. Piping Field Connections: All units, either rigidly mounted or mounted on vibration isolators, shall be attached to the piping system using flexible loops designed for seismic movement. Flexible loops shall be capable of movement in the three axes and must completely isolate the equipment from the piping. The loops shall be suitable for an operating pressure and temperature of the system, refer to Vertiv installation instructions. This includes condensate drainage, and chilled water supply and return. Follow manufacturer's installation instructions for proper seismic application of flexible looping.

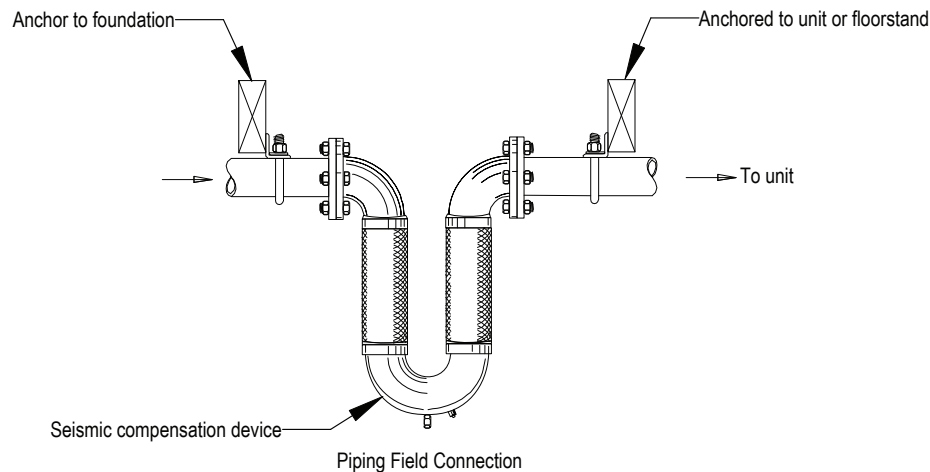

4. Electrical Connections: Must have adequate flexibility for seismic movement. Electrical wiring, conduit, and/or other connections to the equipment is the responsibility of others. Data and recommendations are supplied here and in the unit installation supplement for seismic installation.

CoolLoop Thermal Wall

CA80 DIMENSIONAL DATA SEISMIC 2.5 Sds MOUNTING

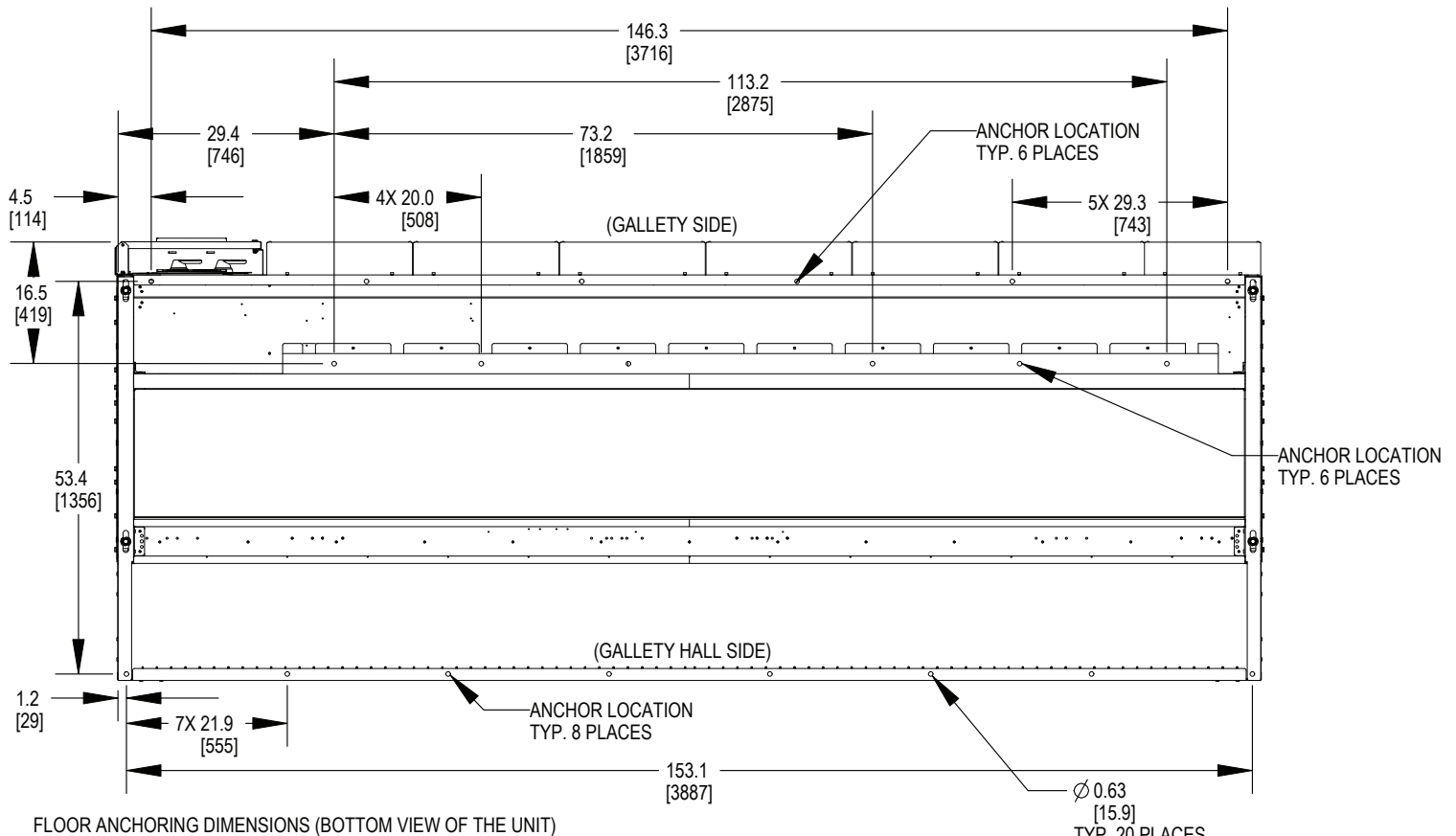

Notes:

1. Anchor Bolt sized per Engineer of Record.
2. Specified by Engineer of Record.
3. Refer to 20000758 for mounting of 2.5 Sds units during installation. Plan for prior to anchoring.
4. With the 575V option, the main transformer must be slightly moved to allow access to the anchor point behind it.

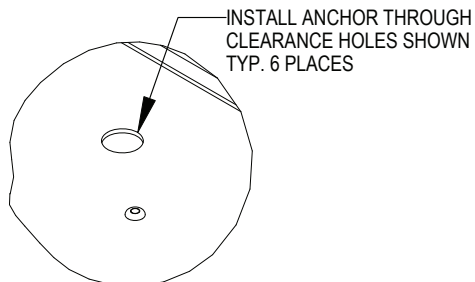

DETAIL A
CLEARANCE HOLES FOR SEISMIC BOLTS TYP. 6 PLACES

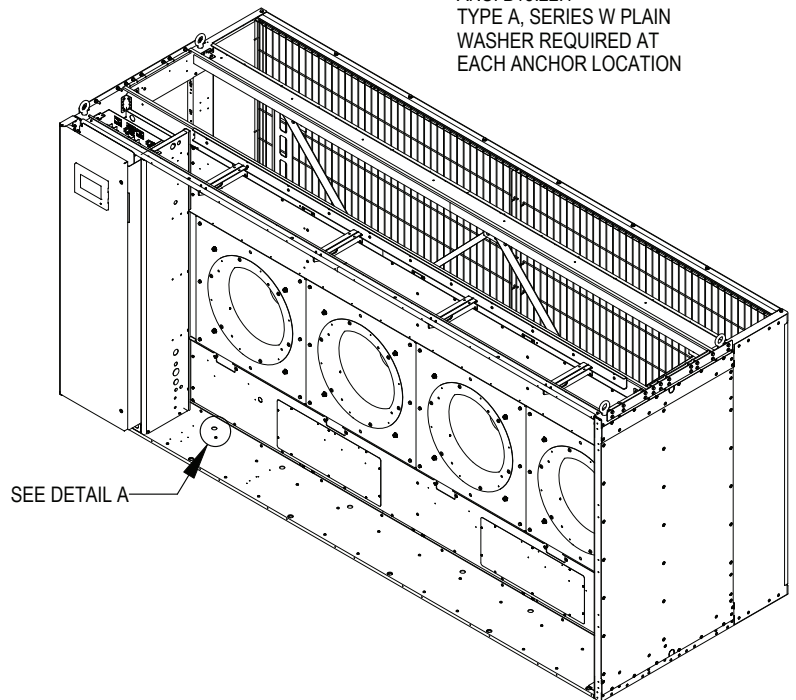

CA80 FILTER AND FILTER RACK REMOVAL

FILTERS ARE REMOVED FROM CENTER POSITION OF THE FILTER RACK.

LIFT THE FILTER UP AND OUT TO REMOVE FROM RACK.

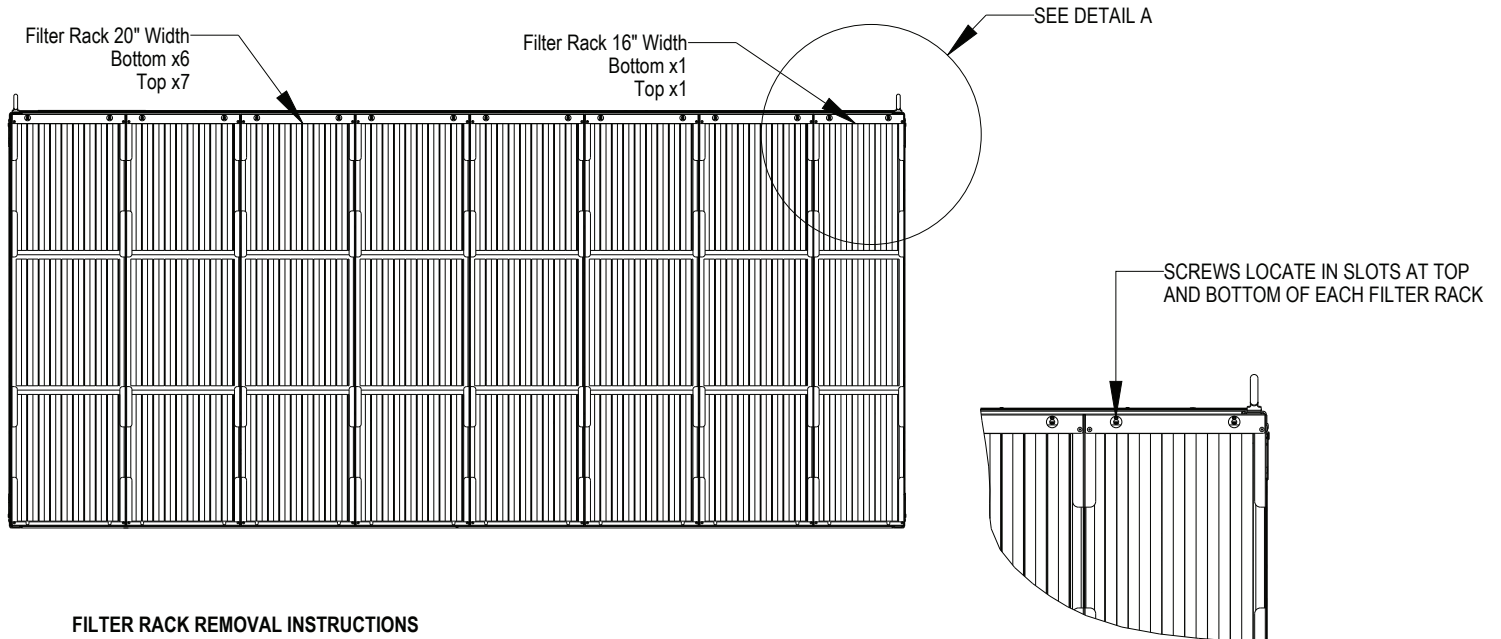
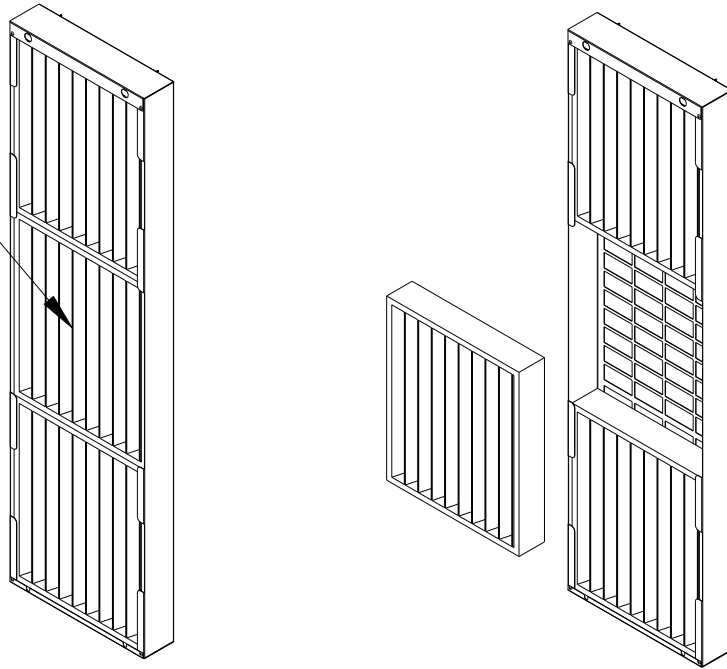

FILTER RACK REMOVAL INSTRUCTIONS

1. REMOVE FILTERS FROM RACK.
2. LOOSEN (2) SCREWS AT THE TOP AND BOTTOM OF FILTER RACK.
3. LIFT FILTER RACK UP AND OUT TO REMOVE THE RACK.

CoolLoop Thermal Wall

CA80 TOP AND BOTTOM MODULE ASSEMBLY

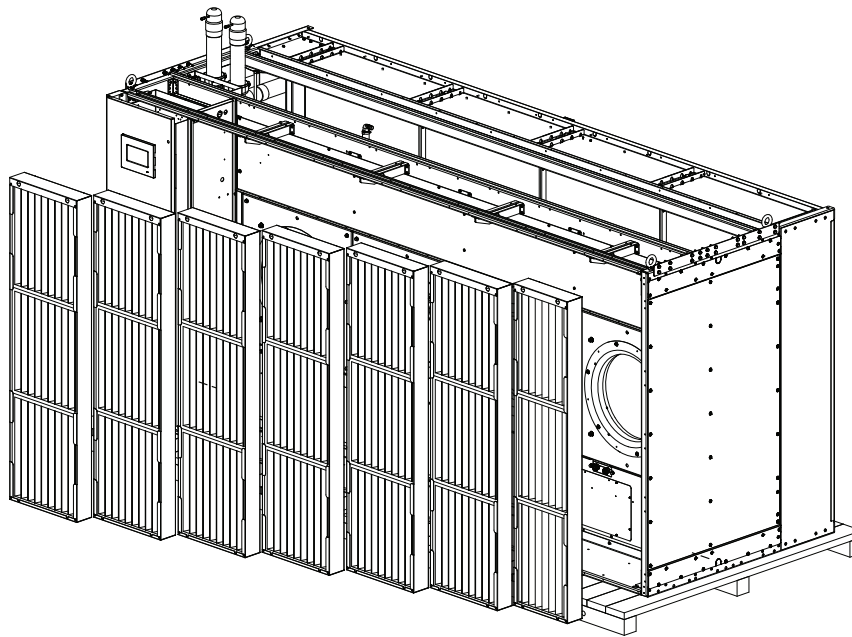
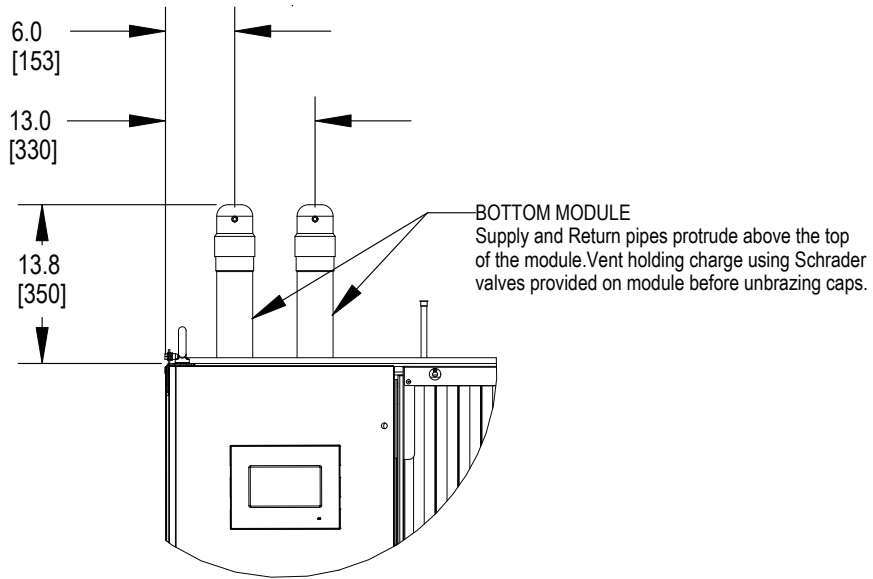

GALLERY SIDE
BOTTOM MODULE

Notes:

1. Remove exterior packaging material from module.
2. Unit ships in two sections, Top module and Bottom module.
3. Each module is fastened to the shipping skid with Lag screws through the provided mounting holes.
4. Remove filter rack assemblies from each module. (See document 20000755 for details on filter rack removal)
5. Dimensions are in in. [mm].

Refer to Vertiv™ CoolLoop Thermal Wall user manual for detailed installation instructions

CoolLoop Thermal Wall

CA80 TOP AND BOTTOM MODULE ASSEMBLY

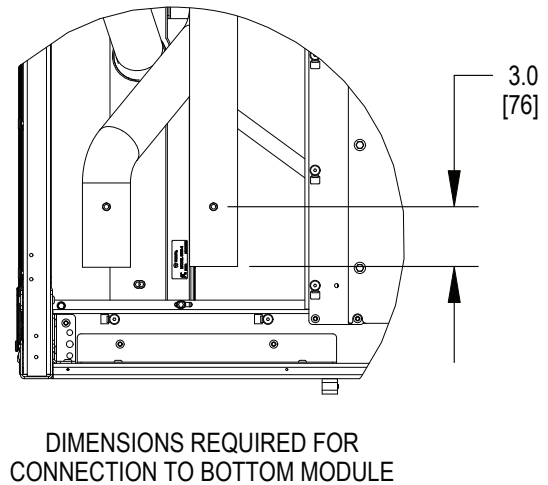
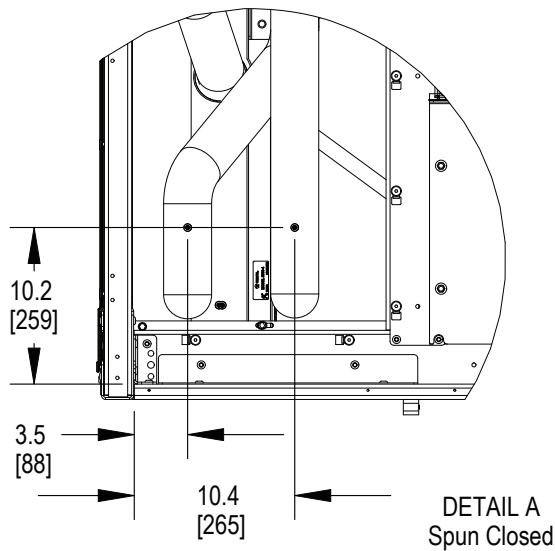
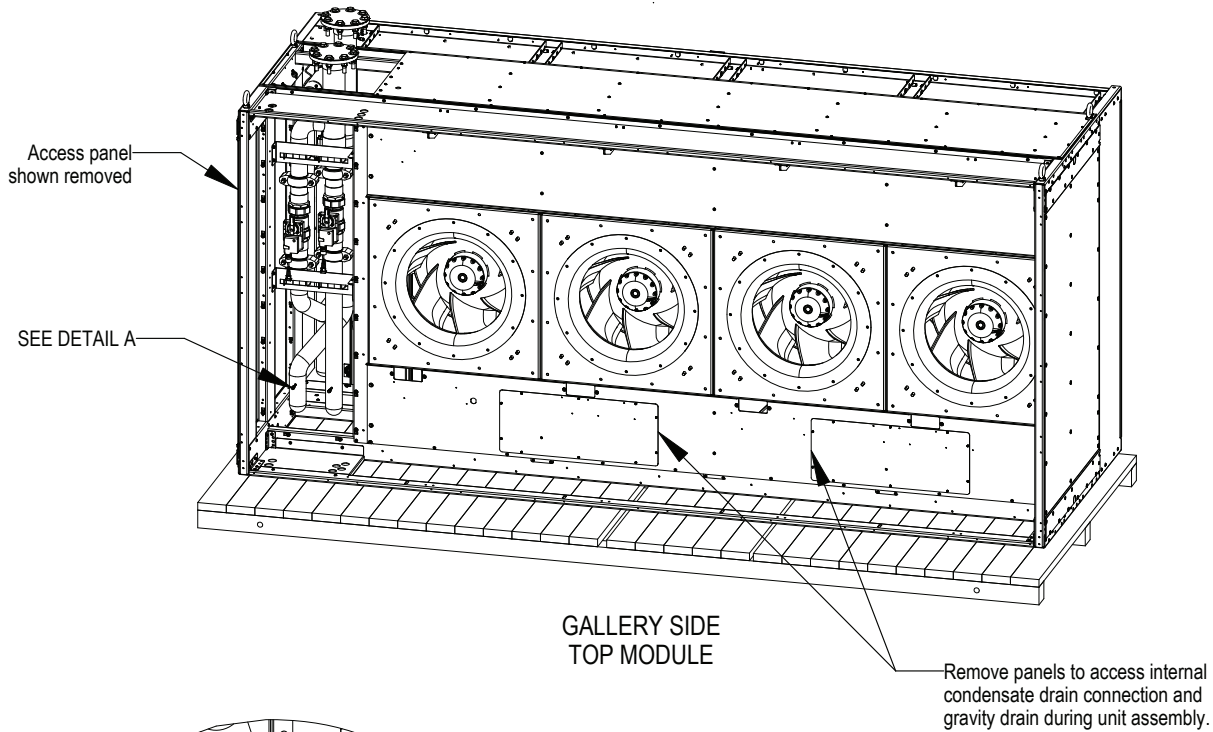

Notes:

1. On Top Module, remove Panel to access the internal piping for the supply and return connections.
2. Vent holding charge using Schrader valves provided on module before removing any fittings. Schrader valves on connections are intended solely for venting the unit.
3. Prepare internal piping connections by cutting to dimensions specified in above details. Remove any excess piping material using a tube cutter or other non burring device. Clean up shavings and other materials before making supply and return piping connections.
4. If the optional Vertiv™ Gravity Drain Condensate Connection Conversion Kit has been purchased, reference the factory provided document (document 20000767) for installation steps.

Refer to Vertiv™ CoolLoop Thermal Wall user manual for detailed installation instructions



CoolLoop Thermal Wall

CA80 TOP AND BOTTOM MODULE ASSEMBLY

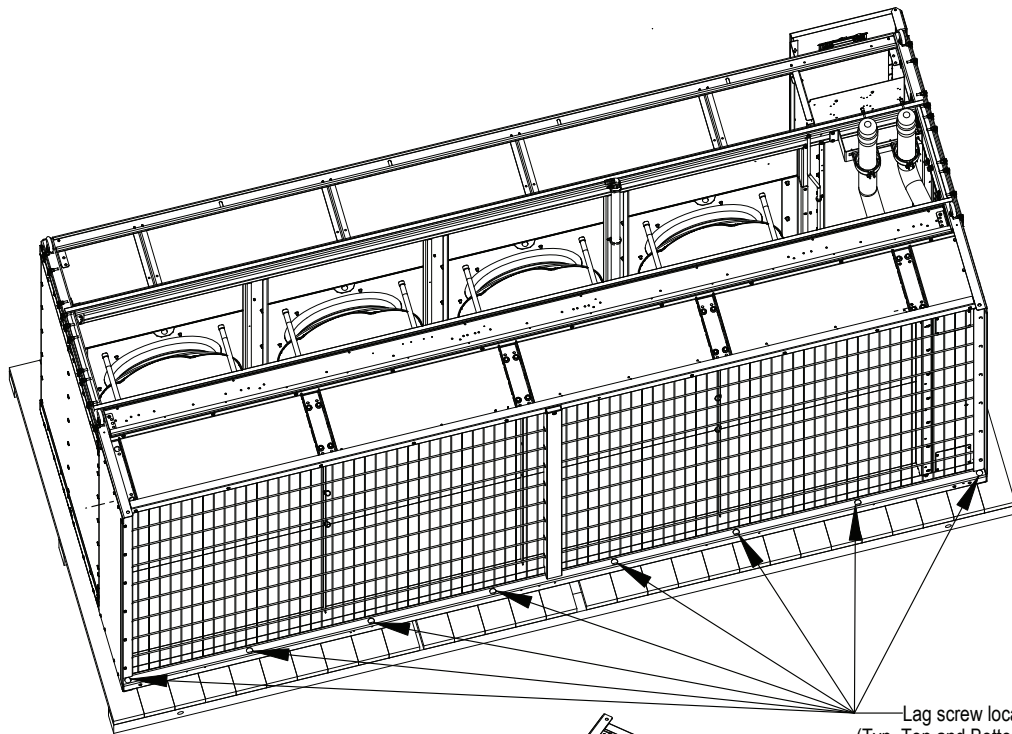

Lag screw location
(Typ. Top and Bottom Module)

Remove cover to access
lag screw location.
(Units with CoolLoop
Thermal Wall Liqui-TECT™
option only)

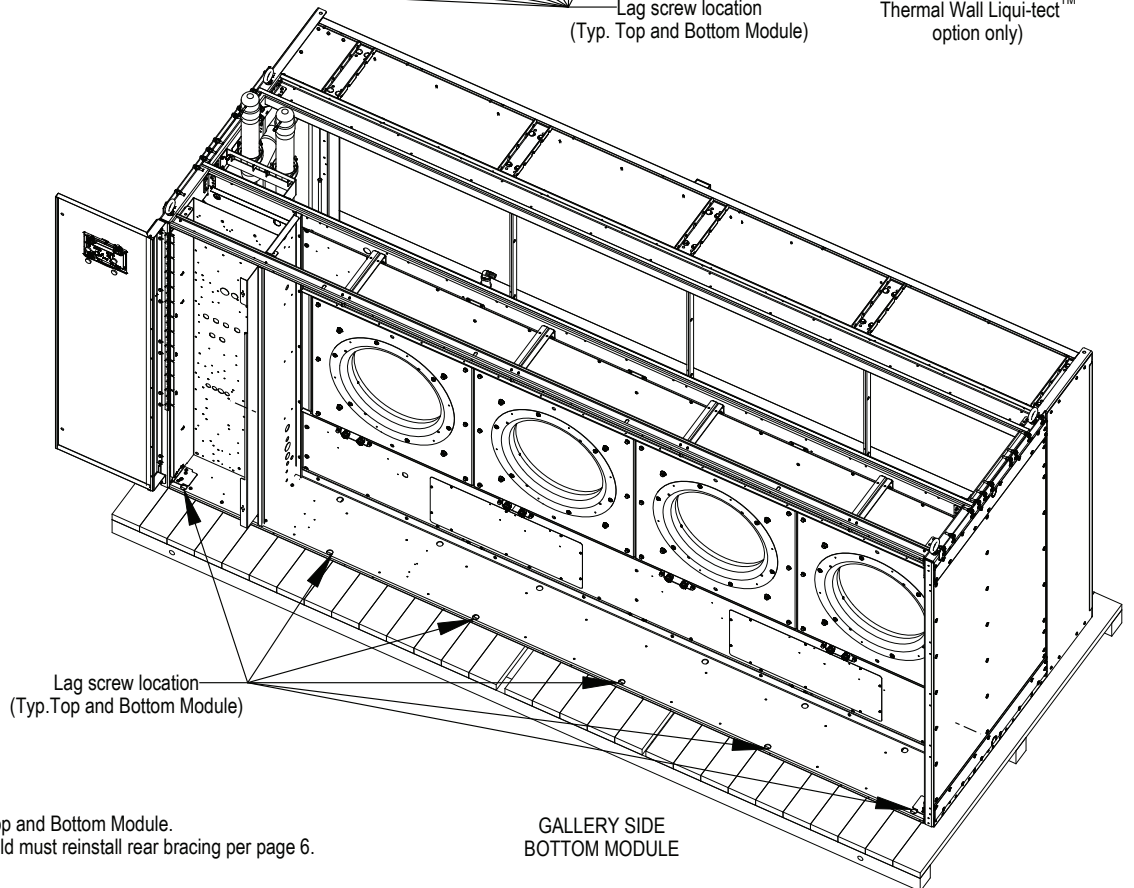

Lag screw location
(Typ. Top and Bottom Module)

GALLERY SIDE
BOTTOM MODULE

Notes:

1. Unbolt Lag screws from skid on Top and Bottom Module.
2. For 2.5 Sds seismic rated units, field must reinstall rear bracing per page 6.

Refer to Vertiv™ CoolLoop Thermal Wall user manual for detailed installation instructions

CoolLoop Thermal Wall

CA80 TOP AND BOTTOM MODULE ASSEMBLY

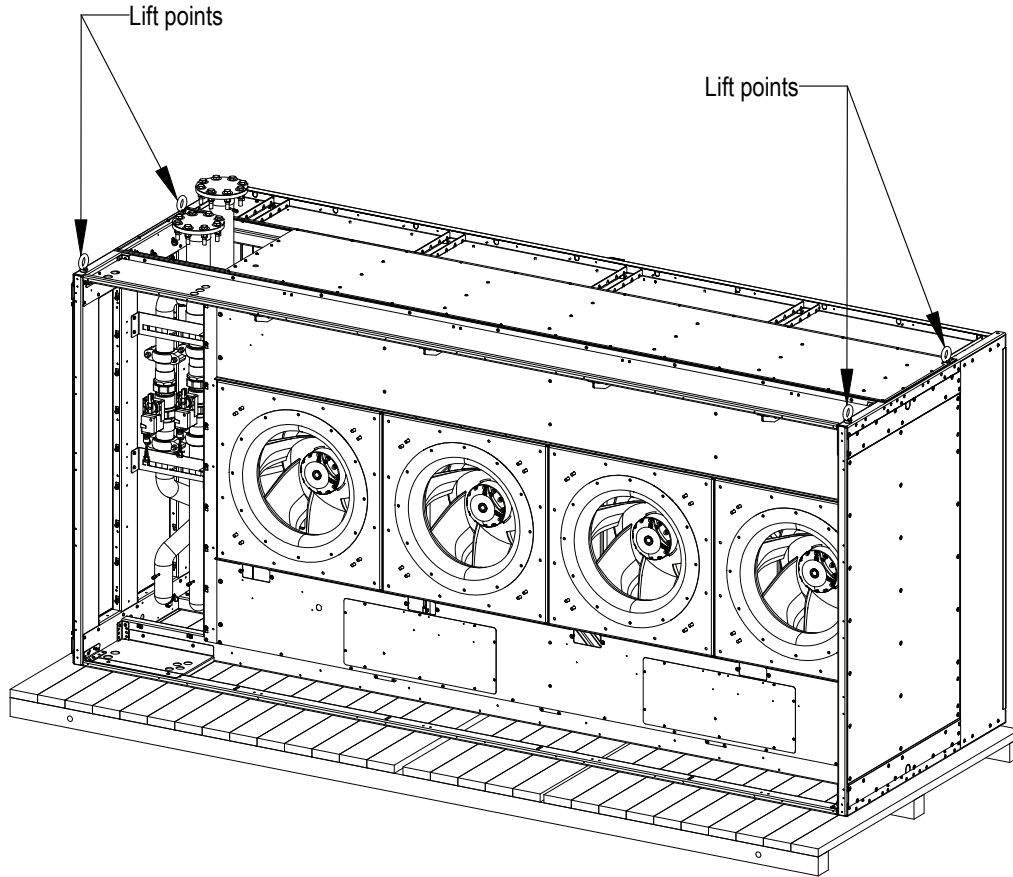

GALLERY SIDE
TOP MODULE

Factory provided fasteners (Qty. 10)
for splice plate.
(Typ. both sides of Top Module)

Notes:

1. Lifting force must be completely vertical at each lift point location.
2. Each module must be lifted separately.
3. After coupling the bottom and top modules, it is not allowed to lift the assembly using any means.

Refer to Vertiv™ CoolLoop Thermal Wall user manual for detailed installation instructions

CoolLoop Thermal Wall

CA80 TOP AND BOTTOM MODULE ASSEMBLY

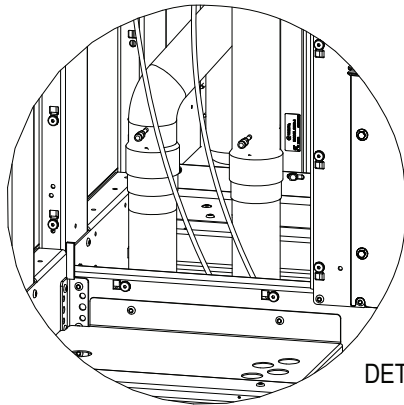

DETAIL B

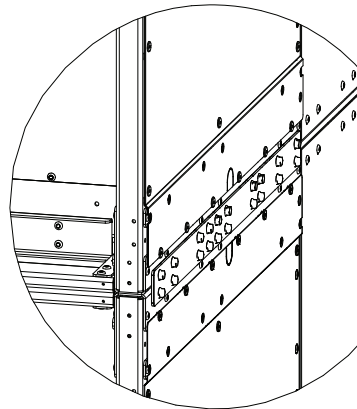

DETAIL C
Splice Plate Detail

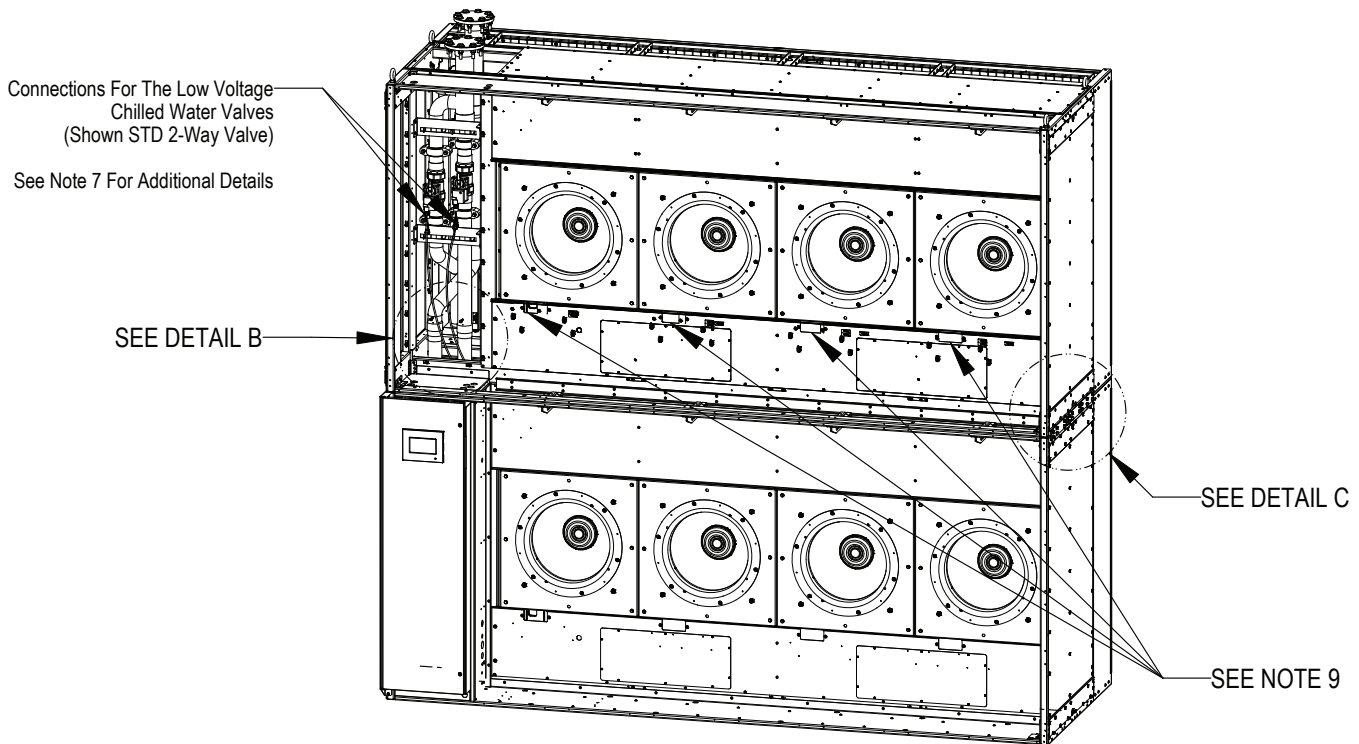

Notes:

1. Field must use a professional rigger to lift and assemble the top and bottom module. Each module must be lifted separately. After coupling the bottom and top modules, it is not allowed to lift the assembly using any means.
2. Modules must be fastened together with factory provided splice plate and fasteners. (Typ. both sides)
3. Braze internal piping connections.
4. Assemble internal Condensate connection between Top and Bottom Module. (See document 20000759 for details)
5. Leak check assembled unit.
6. Field must use a professional rigger to move the assembled unit into place. (See document 20000252 for Bottom Module Mounting. For 2.5 Sds seismic rated units, field must reinstall rear bracing per page 6.
7. Complete electrical connection for the low voltage Chilled Water valves and then reattach panel covers on Top Module piping section and Top and Bottom Module lifting points.
 STD 2-WAY VALVE: 1 valve per circuit, 2 valves in total
 2-WAY EPIV: 2 valves per circuit, 4 valve sin total (power and control cables)
 Valve reference name written on the connectors labels to guarantee the correct electrical connection
8. Complete electrical connection for the supply air sensors system. (See document 20000769 for details)
9. Complete electrical connections for Top Module fans then Reinstall filter racks on Top and Bottom Module.
10. See User Manual to complete unit installation.

Refer to Vertiv™ CoolLoop Thermal Wall user manual for detailed installation instructions



CoolLoop Thermal Wall

CA80 TOP AND BOTTOM MODULE ASSEMBLY EXTERNAL BRACING FOR SEISMIC UNITS

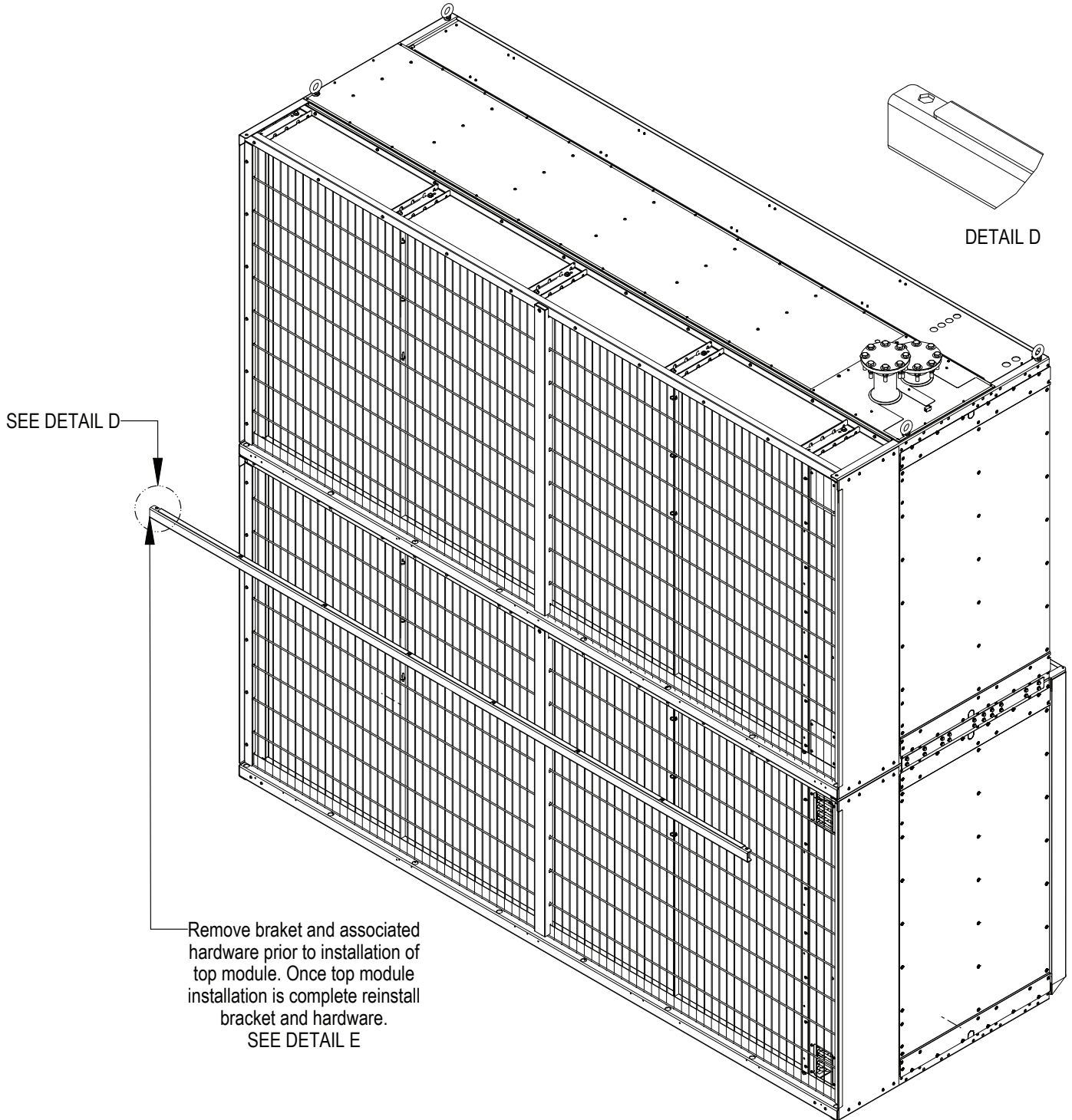

Refer to Vertiv™ CoolLoop Thermal Wall user manual for detailed installation instructions



CoolLoop Thermal Wall

ELECTRICAL FIELD CONNECTIONS

CA80

STANDARD ELECTRICAL CONNECTIONS

1. High voltage entrance - Located in the top of the box (quantity 2).
2. Low voltage entrance - Located in the top of the box (quantity 1-4).
3. Three phase electrical service - Terminals are on top of disconnect switch. Three phase service not provided by Vertiv.
4. Earth ground - Terminal for field supplied earth grounding wire and component ground terminal strip. Earth grounding required for Liebert units.
5. Unit factory installed disconnect switch and Main Fuses - Access to the high voltage electric panel compartment can be obtained only with the switch in the "off" position. Fused disconnects are provided with a defeater button that allows access to the electrical panel when power is on.
6. Remote unit shutdown - Replace existing jumper between terminals 37 & 38 with field supplied normally closed switch having a minimum 75VA, 24VAC rating. Use field supplied Class 1 wiring.
7. Customer alarm inputs - Terminals for field supplied, normally open contacts, having a minimum 75VA, 24VAC rating, between terminals 24 & 50, 51, 55, 56. Use field supplied Class 1 wiring. Terminal availability varies by unit options.
8. Common alarm - On any alarm, normally open dry contact is closed across terminals 75 & 76 for remote indication 1 AMP, 24VAC max load. Use Class 1 field supplied wiring.
9. Unit-to-Unit - Plug 64 is reserved for U2U communication
10. Site and BMS - Plug 74 and terminal block 3 are reserved for Site and BMS connections. Plug 74 is an eight pin RJ45 for a Cat 5 cable. Terminal block 3 is a two-position screw terminal block for use with twisted pair wires.

OPTIONAL LOW VOLTAGE TERMINAL PACKAGE CONNECTIONS

11. Remote unit shutdown - Two additional contact pairs available for unit shutdown (labeled as 37B & 38B, 37C & 38C). Replace jumpers with field supplied normally closed switch having a minimum 75VA, 24VAC rating. Use field supplied Class 1 wiring.
12. Extra Common alarm - On any alarm, two additional normally open dry contacts are closed across terminals 94 & 95 and 96 & 97 for remote indication. 1 AMP, 24VAC max load. Use Class 1 field supplied wiring.
13. Main fan enabled contact - On enable, normally open dry contact is closed across terminals 84 & 85 for remote indication. 1 AMP, 24VAC max load. Use Class 1 field supplied wiring.
14. Liebert® Liqui-Tect™ shutdown and dry contact - On Liqui-Tect activation, normally open dry contact is closed across terminals 58 & 59 for remote indication (Liqui-Tect sensor ordered separately). 1 AMP, 24VAC max load. Use Class 1 field supplied wiring.

OPTIONAL ELECTRICAL CONNECTIONS

15. Smoke sensor alarm - Factory wired dry contacts from smoke sensor are 91-common, 92-NO, and 93-NC. Supervised contacts, 80 & 81, open on sensor trouble indication. This smoke sensor is not intended to function as, or replace, any room smoke detection system that may be required by local or national codes. 1 AMP, 24VAC max load. Use Class 1 field supplied wiring.
16. Analog inputs- Terminals 41, 42, 43, and 44 are user configurable for 0-10V, 0-5V, or 4-20MA.
17. Condensate alarm (with condensate pump option) - On pump high water indication, normally open dry contact is closed across terminals 88 & 89 for remote indication. 1 AMP, 24VAC max load. Use Class 1 field supplied wiring.
18. Remote humidifier - On any call for humidification, normally open dry contact is closed across terminals 11 and 12 to signal field supplied remote humidifier. 1 AMP, 24VAC max load. Use Class 1 field supplied wiring

CoolLoop Thermal Wall

ELECTRICAL FIELD CONNECTIONS CA80

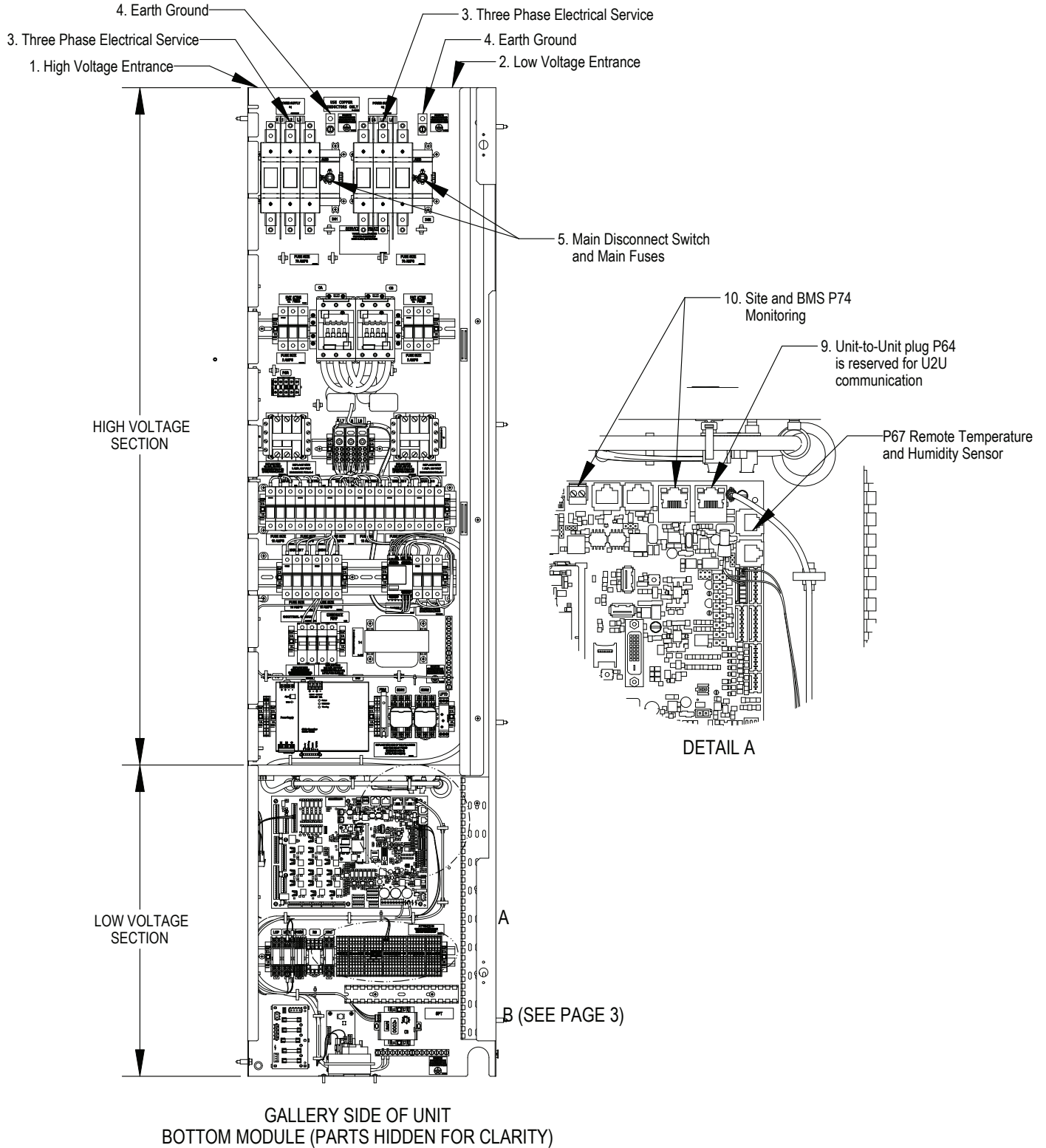

CoolLoop Thermal Wall

ELECTRICAL FIELD CONNECTIONS

CA80

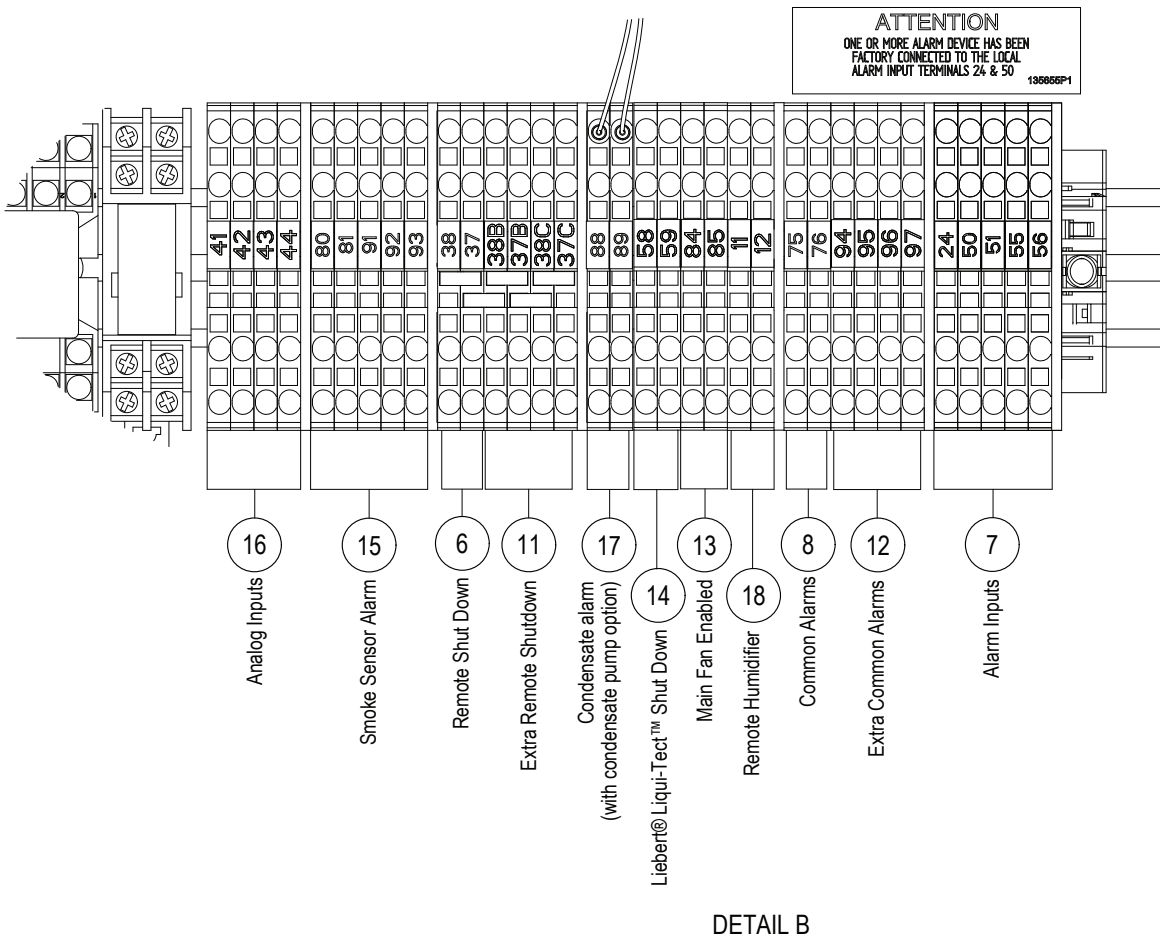

CoolLoop Thermal Wall

ELECTRICAL FIELD CONNECTIONS CA80

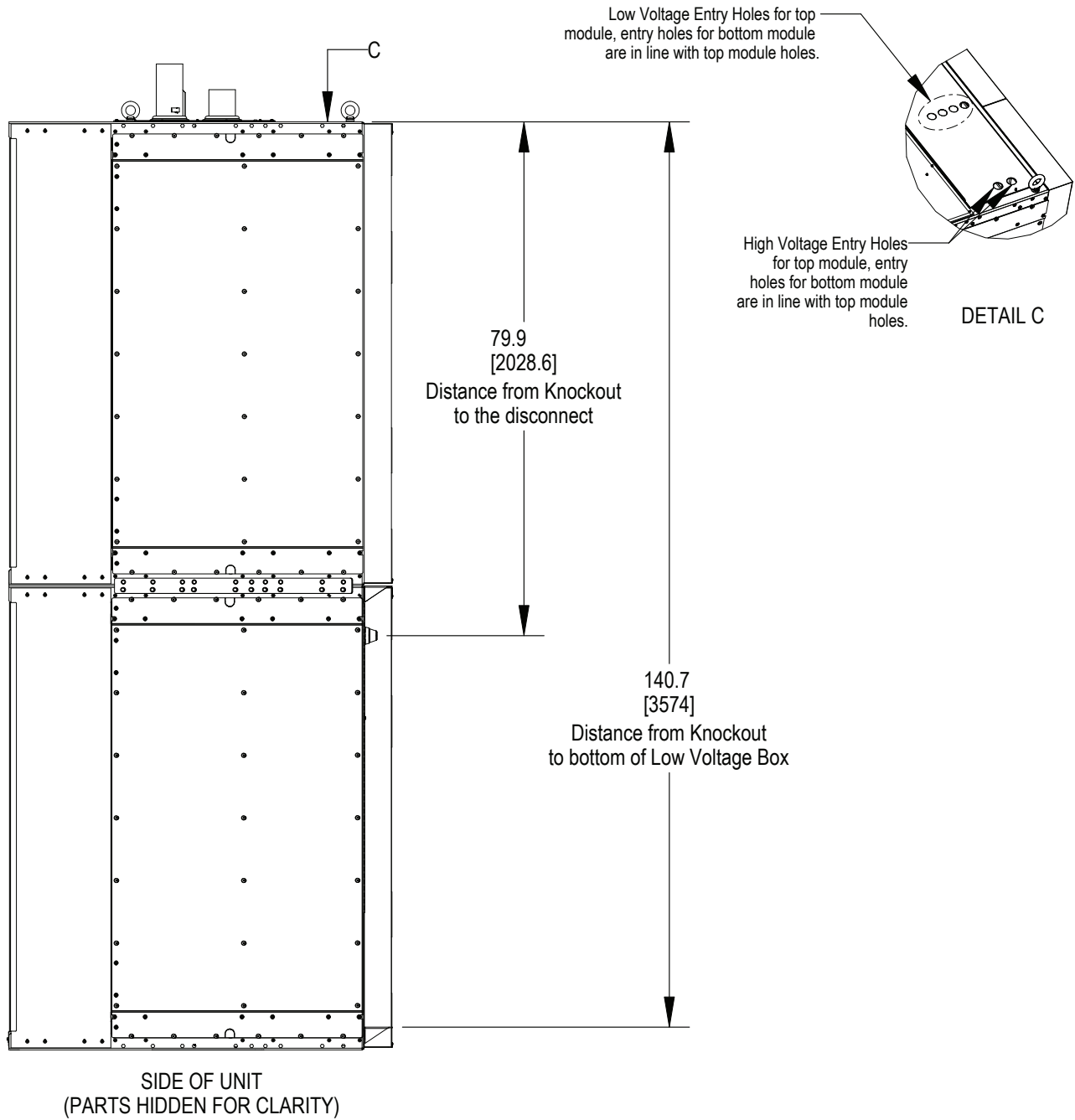

Note:

1. Filter and Filter rack assembly must be removed to access internal electrical knockout
2. The cables must be routed without affecting the accessibility for the standard maintenance operations.



Cool Loop Thermal Wall

ELECTRICAL DATA

Model	Fan Type	Voltage	w/o Condensate Pump			w Condensate Pump			SCCR (kA)
			FLA	WSA	OPD	FLA	WSA	OPD	
CA60	High Airflow High Efficiency Fan	460V/60Hz	31.2	32.5	35	32.4	33.7	35	65
		575V/60Hz	25	26	30	25.9	26.9	30	65
		380V/60Hz	35.4	36.9	40	36.6	38.1	40	65
		380-415V/50Hz	35.4	36.9	40	36.6	38.1	40	65
	High Airflow High Efficiency Fan + THD	460V/60Hz	31.2	32.5	35	32.4	33.7	35	65
		575V/60Hz	25	26	30	25.9	26.9	30	65
		380V/60Hz	35.4	36.9	40	36.6	38.1	40	65
		380-415V/50Hz	35.4	36.9	40	36.6	38.1	40	65
CA80	Ultra Performance Fan	460V/60Hz	48	49.5	50	49.2	50.7	60	65
		575V/60Hz	38.4	39.6	40	39.3	40.5	45	65
		380V/60Hz	59.2	61.1	70	60.4	62.3	70	65
		380-415V/50Hz	59.2	61.1	70	60.4	62.3	70	65
	Ultra Performance Fan + THD	460V/60Hz	46.4	47.9	50	47.6	49.1	50	65
		575V/60Hz	37.6	38.8	40	38.5	39.7	40	65
		380V/60Hz	59.2	61.1	70	60.4	62.3	70	65
		380-415V/50Hz	59.2	61.1	70	60.4	62.3	70	65
	High Airflow High Efficiency Fan	460V/60Hz	41.6	42.9	45	42.8	44.1	45	65
		575V/60Hz	33.3	34.3	35	34.2	35.2	40	65
		380V/60Hz	47.2	48.7	50	48.4	49.9	50	65
		380-415V/50Hz	47.2	48.7	50	48.4	49.9	50	65
	High Airflow High Efficiency Fan + THD	460V/60Hz	41.6	42.9	45	42.8	44.1	45	65
		575V/60Hz	33.3	34.3	35	34.2	35.2	35	65
		380V/60Hz	47.2	48.7	50	48.4	49.9	50	65
		380-415V/50Hz	47.2	48.7	50	48.4	49.9	50	65

PRIMARY CONNECTION LOCATIONS CA80 WITH BRAZED CUSTOMER CONNECTIONS

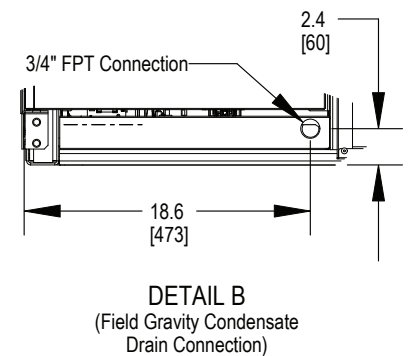
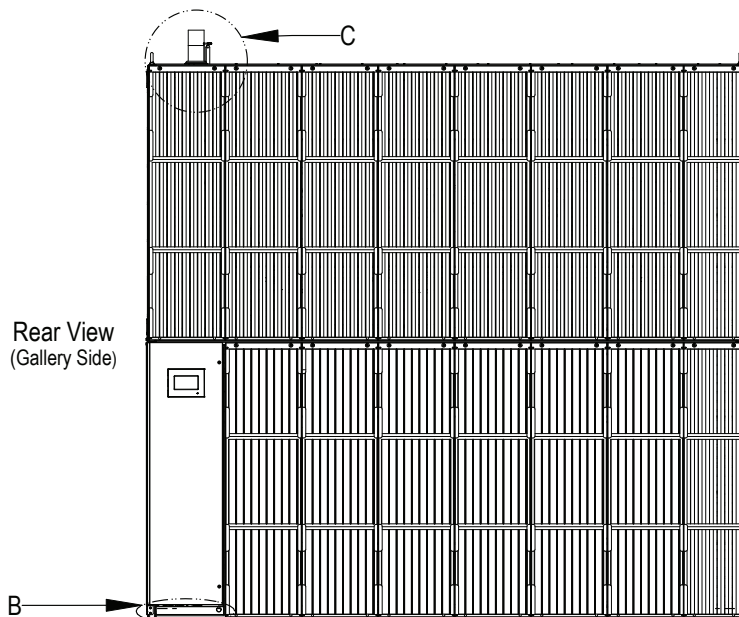
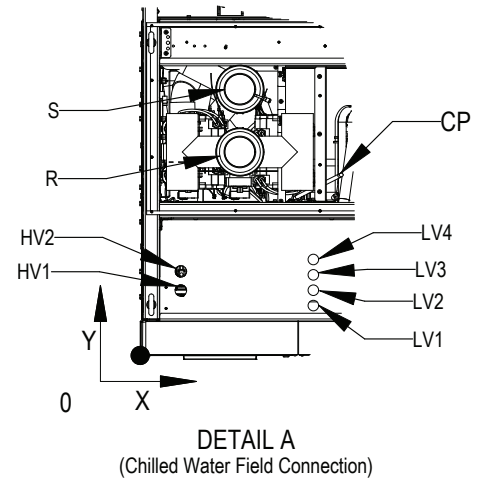
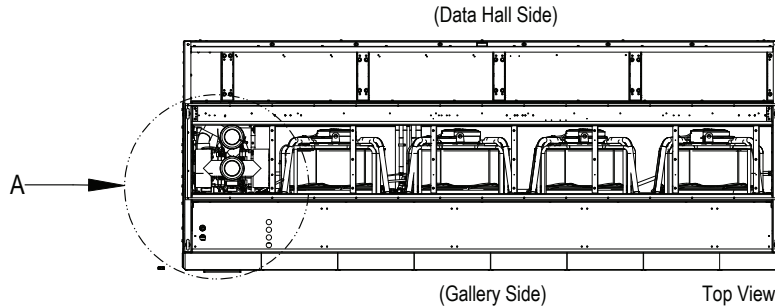

Connection	Description	X in. (mm)	Y in. (mm)	Connection Size Opening
R	Return Pipe Connection	12.7 (323)	26.5 (673)	4" O.D. CU
S	Supply Pipe Connection		34.7 (881)	
LV1	Electrical Connection (Low Volt)	22.3 (566)	6.5 (165)	1-3/8" NOM.
LV2			8.5 (216)	
LV3			10.5 (267)	
LV4			12.5 (317)	
HV1	Electrical Connection (High Volt)	5.0 (128)	8.5 (215)	
HV2			10.9 (278)	
CP	Condensate Pump Connection	25.9 (658)	23.5 (597)	1/2" O.D. CU

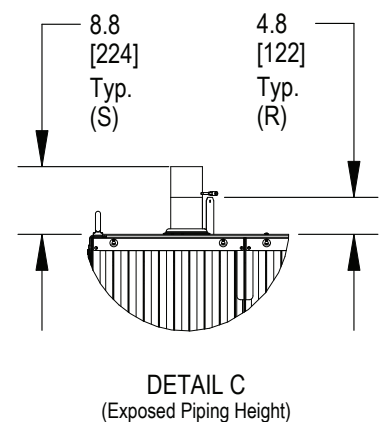

Notes:

1. Drawing not to scale. All dimensions from left corner on Gallery Side and have a tolerance of $\pm 0.5"$ (13mm).
2. The factory unit does not contain a trap. The drain must comply with all local codes. Select appropriate drain system materials. Field pitch Condensate Drain line a minimum 0.13" (3mm) per 12" (305mm).
3. Piping connection can be made at the top of the unit; be sure to have the necessary clearance.



CoolLoop Thermal Wall

PRIMARY CONNECTION LOCATIONS CA80 WITH BRAZED CUSTOMER CONNECTIONS CHILLED WATER COIL DRAIN DETAIL

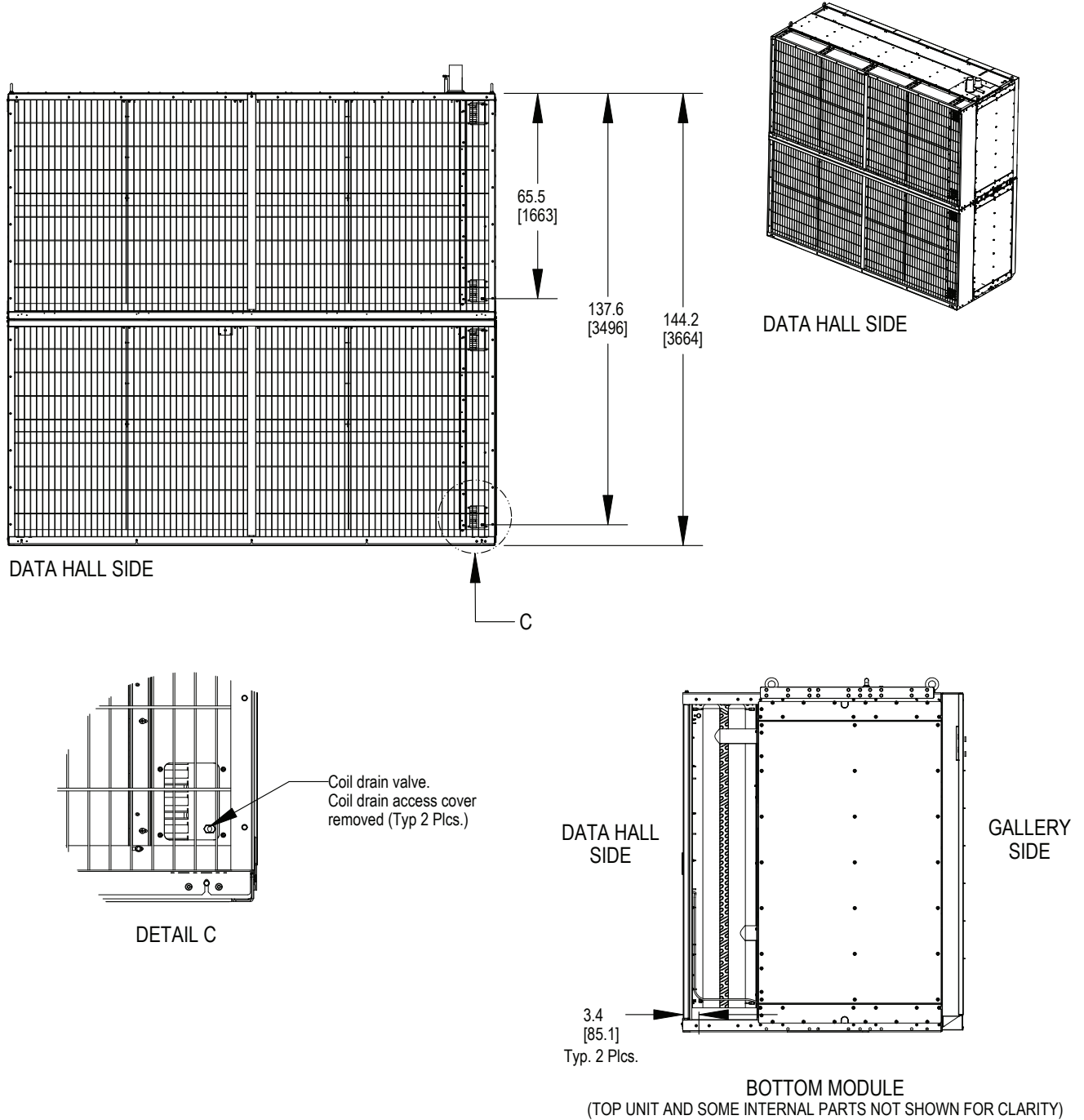

Notes:
1. Drawing not to scale.

PRIMARY CONNECTION LOCATIONS CA80 WITH FLANGED CUSTOMER CONNECTIONS

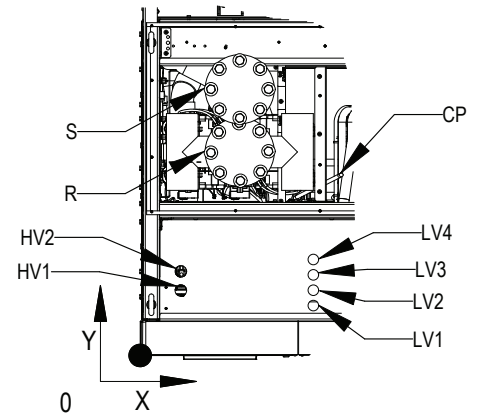
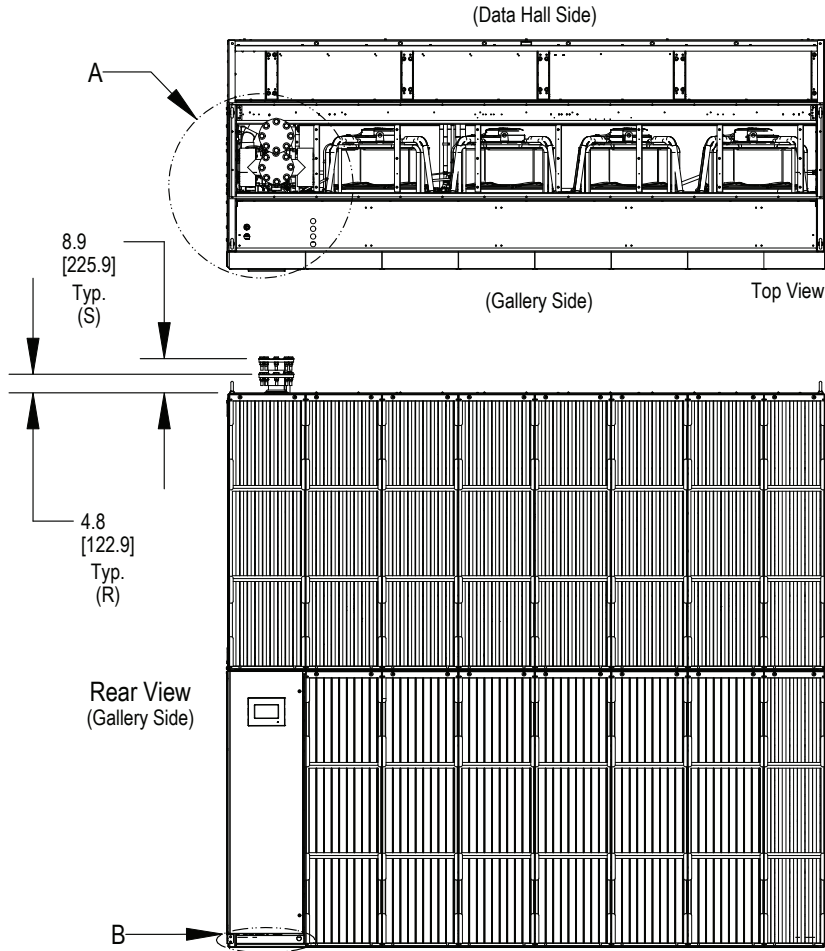

DETAIL A
(Chilled Water Field Connection)

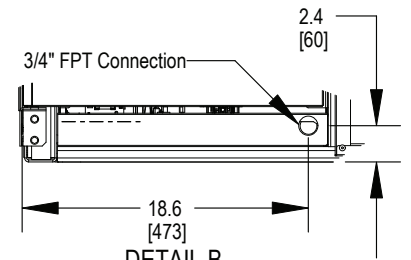

DETAIL B
(Field Gravity Condensate Drain Connection)

Connection	Description	X in. (mm)	Y in. (mm)	Connection Size Opening
R	Return Pipe Connection	12.7 (323)	26.5 (673)	4" (150lb.) Steel Pipe Flange
S	Supply Pipe Connection		34.7 (881)	
LV1	Electrical Connection (Low Volt)	22.3 (566)	6.5 (165)	1-3/8" NOM.
LV2			8.5 (216)	
LV3			10.5 (267)	
LV4			12.5 (317)	
HV1	Electrical Connection (High Volt)	5.0 (128)	8.5 (215)	
HV2			10.9 (278)	
CP	Condensate Pump Connection	25.9 (658)	23.5 (597)	1/2" O.D. CU

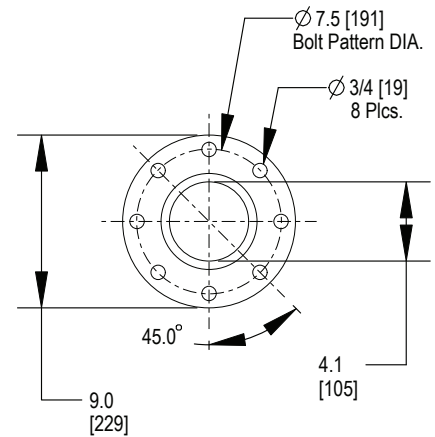

FLANGED CONNECTION DETAIL

Notes:

1. Drawing not to scale. All dimensions from left corner on Gallery Side and have a tolerance of $\pm 0.5"$ (13mm).
2. The factory unit does not contain a trap. The drain must comply with all local codes. Select appropriate drain system materials. Field pitch Condensate Drain line a minimum 0.13" (3mm) per 12" (305mm).
3. Piping connection can be made at the top of the unit; be sure to have the necessary clearance.

CoolLoop Thermal Wall

PRIMARY CONNECTION LOCATIONS CA80 WITH FLANGED CUSTOMER CONNECTIONS CHILLED WATER COIL DRAIN DETAIL

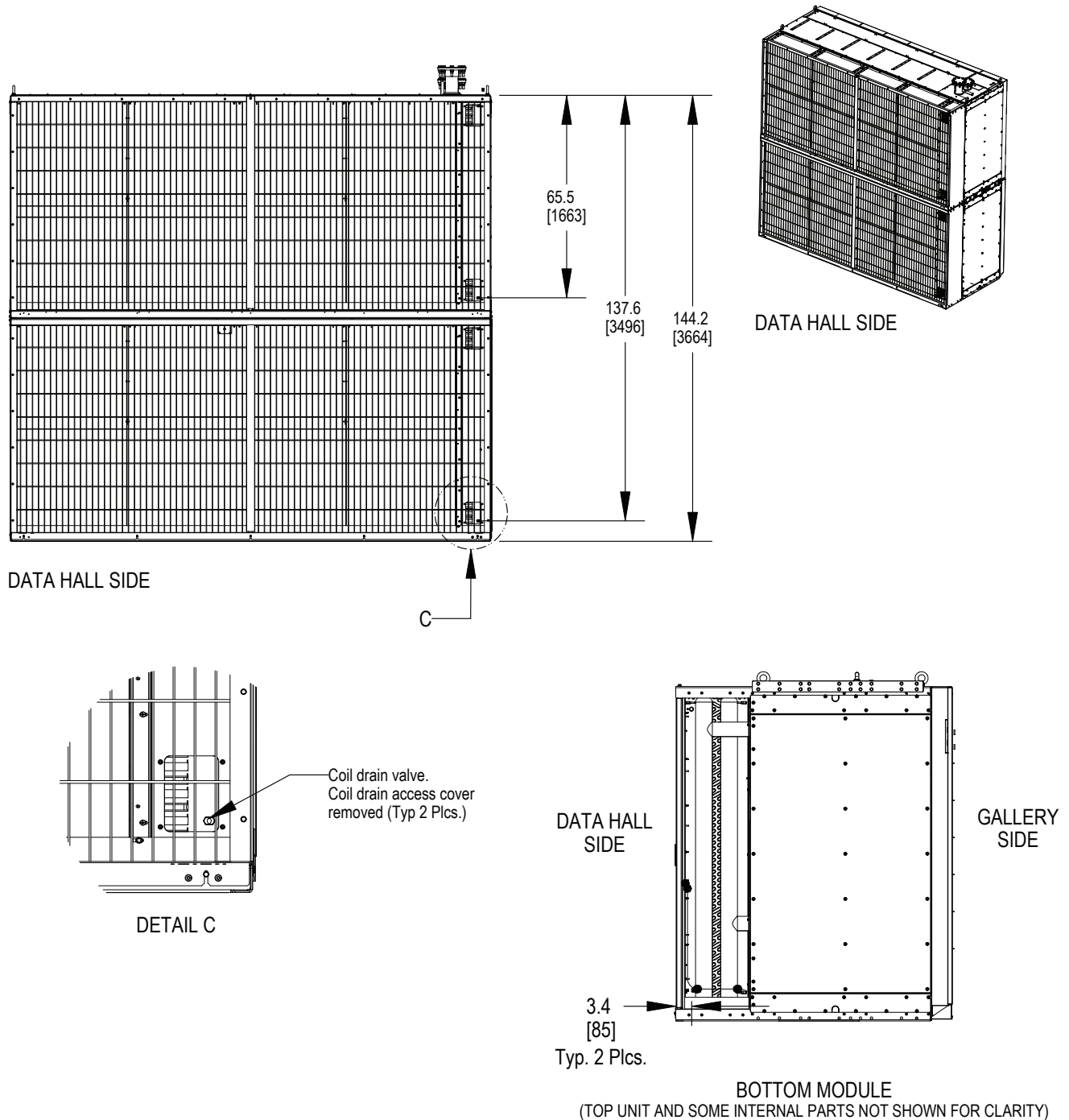

Notes:
1. Drawing not to scale.

PRIMARY CONNECTION LOCATIONS CA80 WITH GROOVED CUSTOMER CONNECTIONS

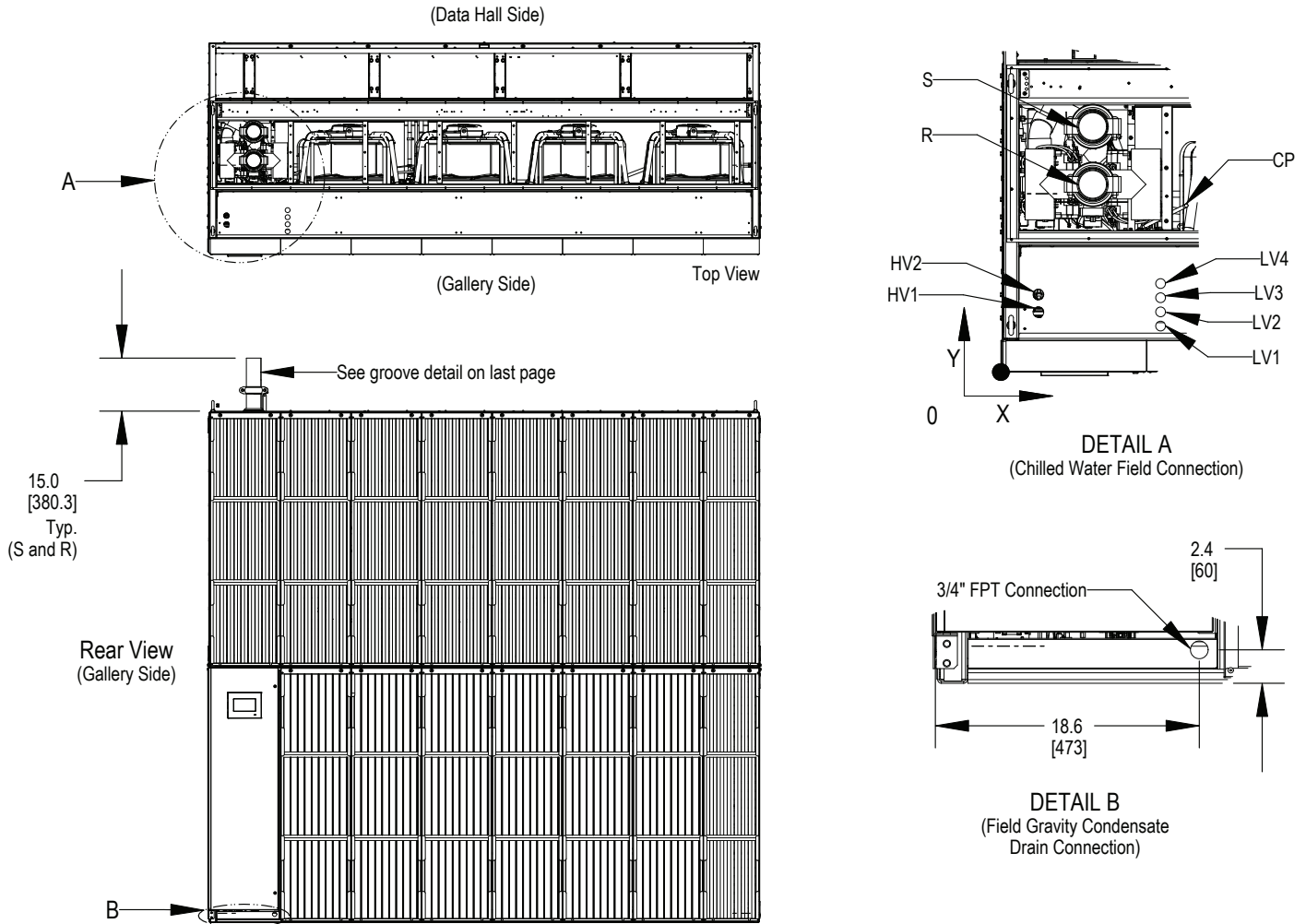

Connection	Description	X in. (mm)	Y in. (mm)	Connection Size Opening
R	Return Pipe Connection	12.7 (323)	26.5 (673)	4" O.D. CU GROOVED
S	Supply Pipe Connection		34.7 (881)	
LV1	Electrical Connection (Low Volt)	22.3 (566)	6.5 (165)	1-3/8" NOM.
LV2			8.5 (216)	
LV3			10.5 (267)	
LV4			12.5 (317)	
HV1	Electrical Connection (High Volt)	5.0 (128)	8.5 (215)	
HV2			10.9 (278)	
CP	Condensate Pump Connection	25.9 (658)	23.5 (597)	1/2" O.D. CU

Notes:

1. Drawing not to scale. All dimensions from left corner on Gallery Side and have a tolerance of $\pm 0.5"$ (13mm).
2. The factory unit does not contain a trap. The drain must comply with all local codes. Select appropriate drain system materials. Field pitch Condensate Drain line a minimum 0.13" (3mm) per 12" (305mm).
3. Piping connection can be made at the top of the unit; be sure to have the necessary clearance.

CoolLoop Thermal Wall

PRIMARY CONNECTION LOCATIONS CA80 WITH GROOVED CUSTOMER CONNECTIONS CHILLED WATER COIL DRAIN DETAIL

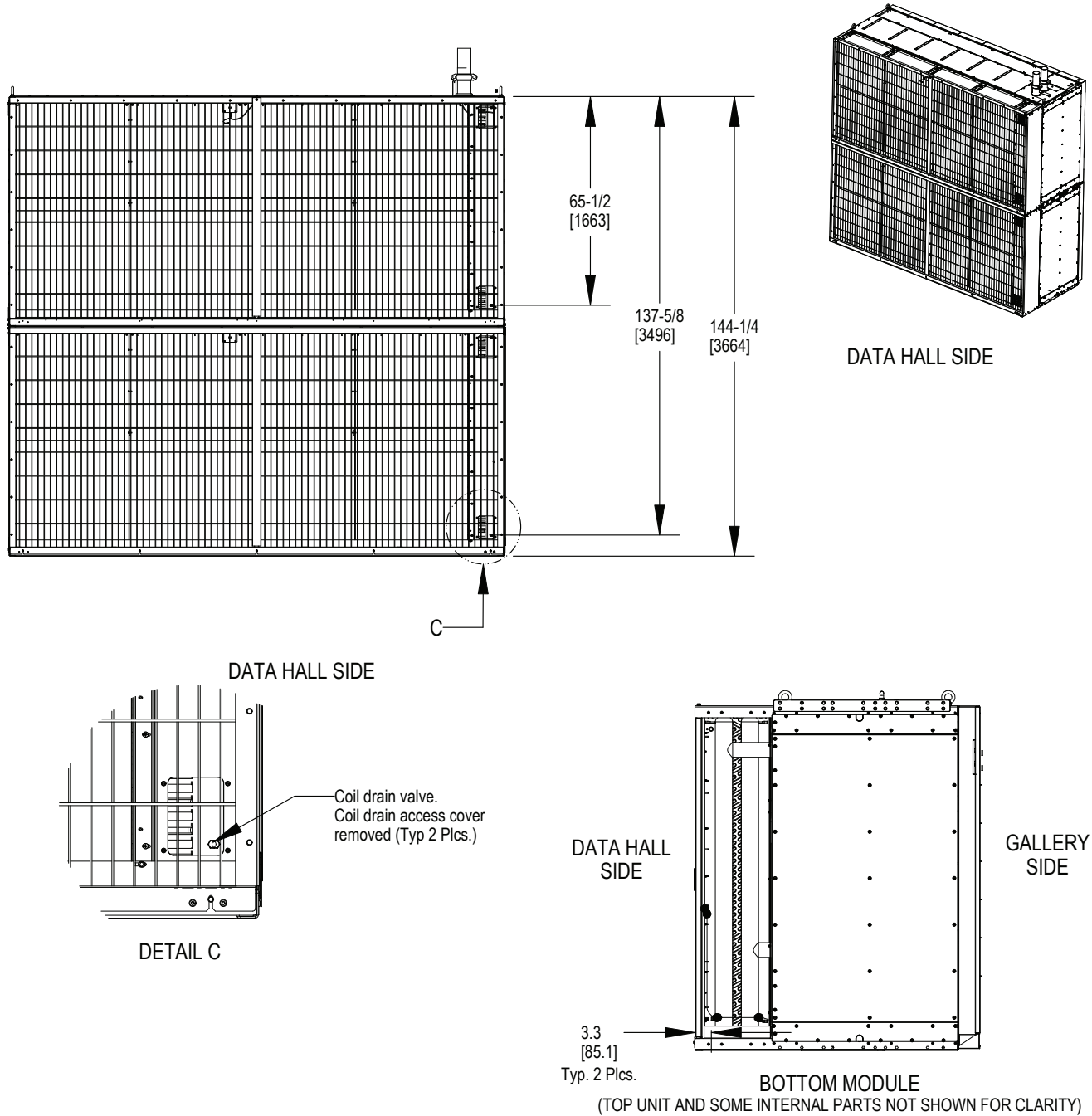

Notes:

1. Drawing not to scale.

CoolLoop Thermal Wall

PRIMARY CONNECTION LOCATIONS CA80 WITH GROOVED CUSTOMER CONNECTIONS

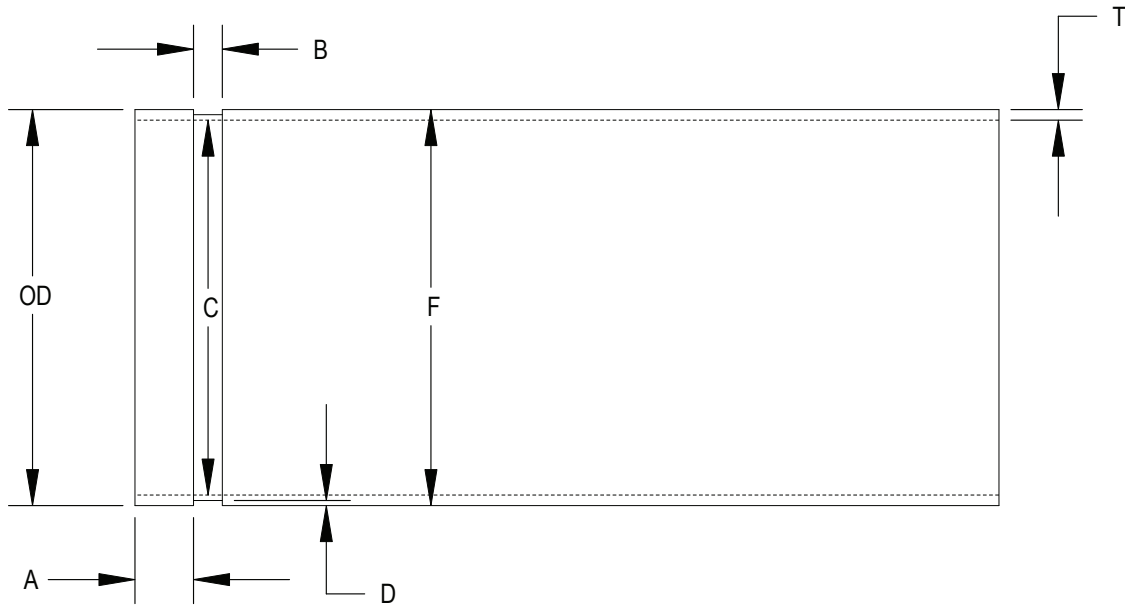

Dimension	Description	Value in. (mm)	Tolerance in. (mm)
OD	Actual Outside Diameter	4.125 (104.8)	0.002 (0.05)
A	Gasket Seat	0.610 (15.5)	±0.03 (0.76)
B	Groove Width	0.300 (7.6)	+0.03/-0.00 (+0.76/-0.00)
C	Groove Diameter	4.019 (102.1)	+0.000/-0.020 (+0.00/-0.50)
D	Groove Depth	0.053 (1.4)	-
T	Min. Allow. Wall Thickness	DWV*	-
F	Max. Allow. Flare Diameter	4.174 (106.0)	-

*ASTM B306 drain waste and vent (DWV) is minimum wall thickness copper tubing which may be roll grooved.

AUTOMATIC TRANSFER SWITCH

CONTROL MODULE

OVERVIEW OF LOVATO ATS, MODELS ATL610 & ATL800

Vertiv™ Thermal Management units equipped with the optional Lovato ATS (automatic transfer switch) control, will automatically switch over to a secondary power source upon loss of primary power. It will also return to the primary power source when it is determined it is available.

When units are equipped with the optional Capacitive Buffer feature, it will not only keep the Vertiv™ iCOM™ control powered (minimum of 3 minutes) during a loss of power, but will also keep the ATS electronics powered when neither the primary or secondary source are available, allowing for a quick unit response when power is restored.

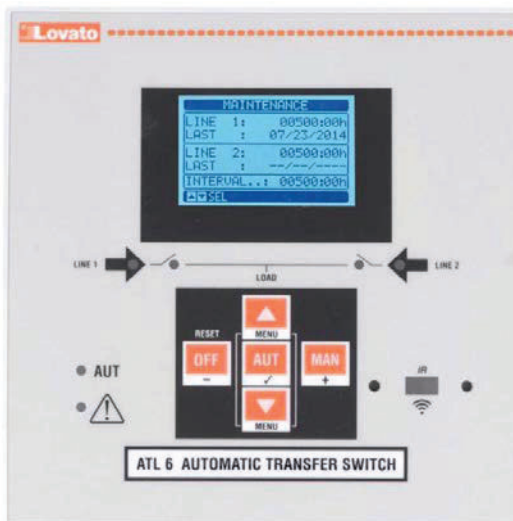

ATL610 (Units up to 460V)

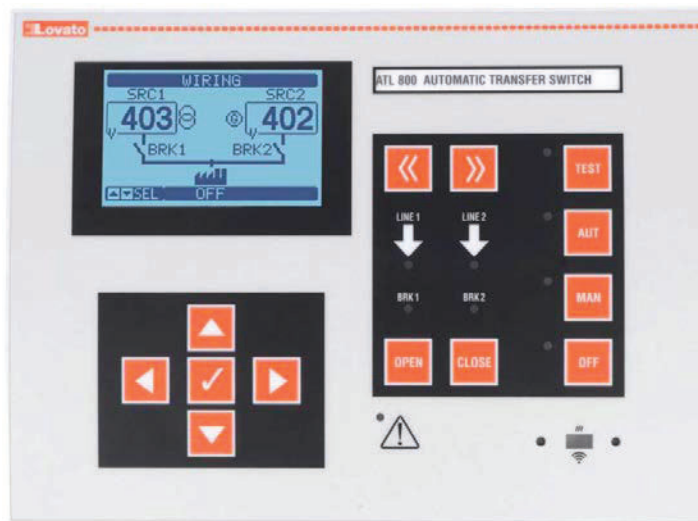

ATL800 (575V Units)

Lovato ATS, model ATL610 (or ATL800) shown in images above, will be located within the cabinet of the units.

AUTOMATIC TRANSFER SWITCH

CONTROL MODULE

KEY CAPABILITIES OF LOVATO ATS, MODELS ATL610 & ATL800

The Lovato ATS, model ATL610 (or ATL800), will be the primary unit level device for switching between power sources. This control will be capable of the following features:

- Determine if power is available in both primary and secondary sources
- Allow for selection of which source is primary and which is secondary
- Ability to automatically switch from primary to secondary source, in the event of primary power loss
- Ability to automatically switch secondary to primary source when primary power returns
- Visible indication of available power sources
- Visible indication of power source that is currently active

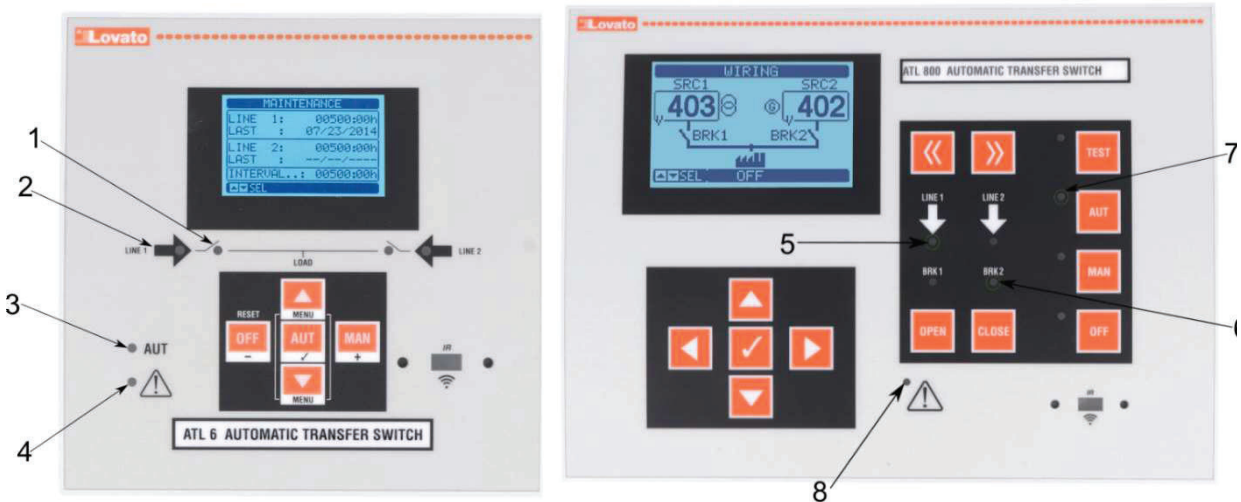

Item #	Description for ATL610 Display	Item #	Description for ATL800 Display
1	LEDs indicate which source is active	5	LEDs indicate if a source is available
2	LEDs indicate if a source is available	6	LEDs indicate which source is active
3	Controller is in automatic mode	7	Controller is in automatic mode
4	Alarm is present	8	Alarm is present

ATL610 (Units up to 460V)

ATL800 (575V Units)

AUTOMATIC TRANSFER SWITCH

CONTROL MODULE

INTERACTION OF LOVATO ATS WITH VERTIV™ iCOM™ CONTROL

The Vertiv™ iCOM™ control will pull key information from the Lovato ATS, allowing for easy interpretation of the current operation without needing to open the unit's front panel, potentially interrupting operation.

***Identification of current power source and power source availability**

*Available via PA2.06.54.04R or greater

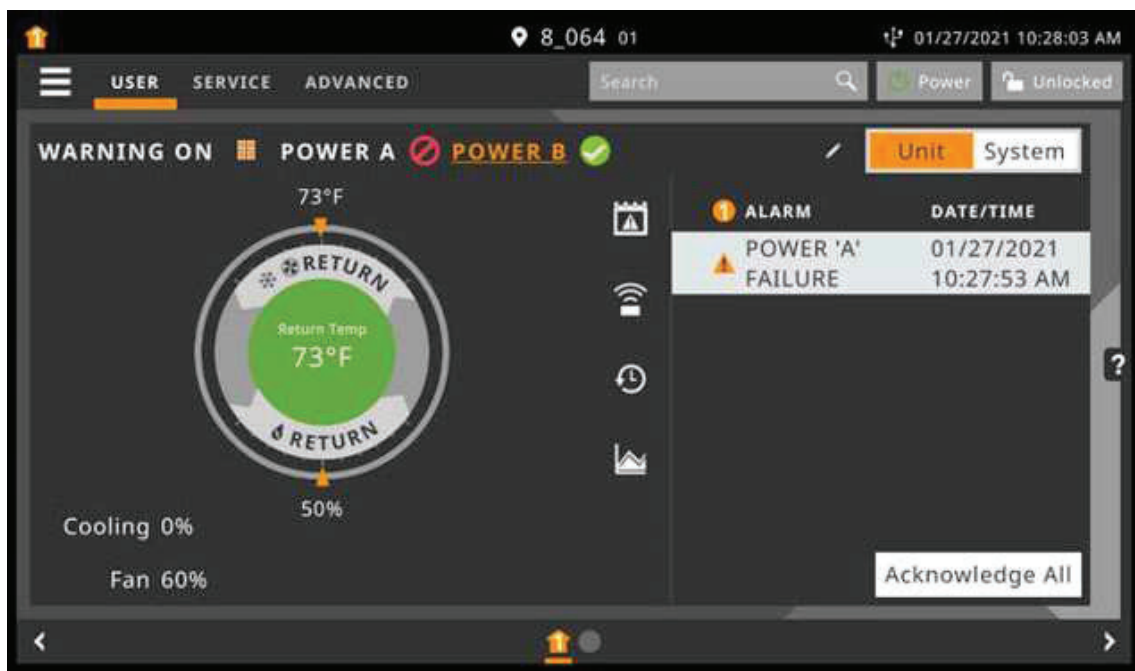

Power source availability

- GREEN circle w/ check mark = power source available
- RED circle w/ cross = power source not available

Power Source A/B utilization

- ORANGE highlighted & underlined power source title = current power source being utilized.

AUTOMATIC TRANSFER SWITCH

CONTROL MODULE

KEY PARAMETERS OF LOVATO ATS, MODELS ATL610 & ATL800

There are multiple key parameters that are factory set by Vertiv to recommended values. Please consult a Vertiv factory technician before making any changes to these parameters.

- Priority power source selection (default = Source 1)
- Switching delay between power sources
 - if secondary power source is present at time of primary failure, delay is up to 11s (default, adjustable via multiple parameters)
 - if secondary power source is ***NOT*** present at time of primary failure, delay is 10s (default, adjustable) after secondary power source is available
- Unit would be removed from active power source in following conditions:
 - Voltage Limit: If voltage is outside of a set limit for a set period (default = 5s)
 - Min Voltage Limit = 85% (default) of nominal
 - Max Voltage Limit = 115% (default) of nominal
 - Voltage Imbalance: If voltage imbalance (asymmetry) is greater than 15% (default) for a set period (default = 5s)
 - Phase Loss: If a phase falls below 70% (default) of nominal for a set period (default = 0.1s)
 - Frequency Limit: If frequency is outside of a set limit for a set period (default = 3s)
 - Min Freq Limit = 95% (default)
 - Max Frequency Limit = 105% (default)

Please note that not all parameters are applicable to Vertiv equipment operation. Consult a Vertiv factory technician before making any changes to these parameters.

AUTOMATIC TRANSFER SWITCH

CONTROL MODULE

MONITORING FUNCTIONS OF LOVATO ATS, MODELS ATL610 & ATL800

The voltage and frequency information from the ATS can be displayed on the Vertiv™ iCOM™ user interface, as shown in the below image. Further information is available via BMS monitoring through the Vertiv™ iCOM™ Unity Card / Embedded Unity (BACnet MSTP, BACnet IP, Modbus TCP/IP, Modbus RTU, SNMP v2, v3). The items are outlined in the table on the following page.

ATS voltage & frequency summary page

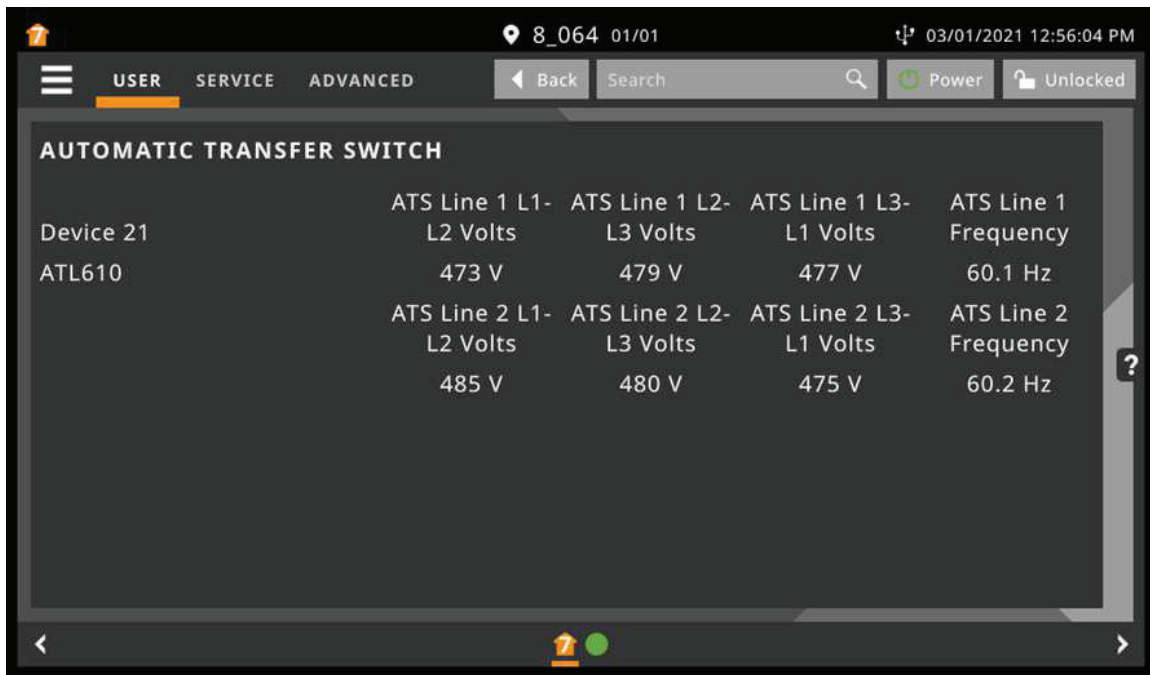

Device 21	ATS Line 1 L1- L2 Volts	ATS Line 1 L2- L3 Volts	ATS Line 1 L3- L1 Volts	ATS Line 1 Frequency
ATL610	473 V	479 V	477 V	60.1 Hz
	ATS Line 2 L1- L2 Volts	ATS Line 2 L2- L3 Volts	ATS Line 2 L3- L1 Volts	ATS Line 2 Frequency
	485 V	480 V	475 V	60.2 Hz



AUTOMATIC TRANSFER SWITCH

CONTROL MODULE MONITORING POINTS

The below ATS specific points can be monitored through a BMS system. Alarm codes at the ATS panel will not match the BMS alarm but can be cross referenced in this chart. Please note that these points are read only.

Lovato Code (at ATS)	Vertiv Alarm (BMS)	Description
ATS_EvLdTO	ATS Load Not Powered Timeout	Unit has not been powered after preset delay (default = 60s).
ATS1_L1L2	Power Source: L1-L2 voltage	Voltage reading phase L1-L2
ATS1_L2L3	Power Source: L2-L3 voltage	Voltage reading phase L2-L3
ATS1_L3L1	Power Source: L3-L1 voltage	Voltage reading phase L3-L1
ATS1_Freq	Power Source: Line Frequency	Measured frequency, per source.
ATS1_BrkOp	Power Source: Breaker Operation Count	Available to be turned on by customer, would indicate number of operations per source.
ATS1VAIOk	Power Source: All status are okay	All parameters are within limits, per source.
ATS1VLo	Power Source: Voltage Is Too Low	Voltage on active source is below acceptable range.
ATS1VHi	Power Source: Voltage Is Too High	Voltage on active source is above acceptable range.
ATS1VAAsymm	Power Source: Voltages Are Asymmetric	Voltages imbalance alarm
ATS1VPhsLs	Power Source: Voltage Phase Loss	Indicates one of the phases voltage has dropped below 70% nominal.
ATS2VPhsSq	Power Source: Phase Sequence Issue	Indicates the incoming power wasn't wired per the phase sequence configured (L1-L2-L3).
ATS1VFrqLo	Power Source: Frequency Is Too Low	Frequency on active source is below acceptable range.
ATS1VFrqHi	Power Source: Frequency Is Too High	Frequency on active source is above acceptable range.
ATS2BCIsd	Power Source: Breaker is closed	ATS is receiving feedback that the indicated contactor as closed.
ATS2BCCIsd	Power Source: Breaker command status closed	ATS is directing the indicated contactor to close.
ATS1EvBTim	Power Source: Breaker Timeout Issue	The indicated changeover device did not complete the

AUTOMATIC TRANSFER SWITCH

CONTROL MODULE

CHANGE OVER CIRCUIT SEQUENCE OF OPERATIONS

Source 1 is out of range

- 1) Source 1 exceeds one or more limits of voltage, frequency, phase, or voltage symmetry.
- 2) A delay timer will begin to count. The amount of time depends on which Source 1 parameter is out of spec, and the value saved in the following parameters. The parameters below are the delays for each condition.

Description	Default	Parameter	
		ATL610	ATL800
Voltage below the minimum limit	5s	P06.03	P09.01.03
Voltage above the maximum limit	5s	P06.06	P09.01.06
Phase failure	0.1s	P06.10	P09.01.10
Voltage exceeds the asymmetry limits	5s	P06.12	P09.01.12
Frequency exceeds the maximum limit	3s	P06.14	P09.01.14
Frequency exceeds the minimum limit	5s	P06.16	P09.01.16

- 3) Once the delay timer is finished, the following events will occur.
 - a. The transfer controller will de-energize Source 1 contactor coil.
 - b. The transfer controller will signal the unit is no longer being powered by Source 1.
 - c. An auxiliary switch NO contact on Source 1's contactor will open, sending a signal to the transfer controller. This signal verifies that the load is not connected to Source 1.
 - d. The NC contacts of the same auxiliary switch will close to allow the coil of the Source 2 contactor to be energized. The Source 2 contactor coil is not energized at this time.
- 4) Once the transfer controller output has opened, a delay timer will begin using the value entered under parameter P05.03 (ATL610) or P07.01.02 (ATL800), default = 6s. **This value should not be decreased without consent from Vertiv.**
- 5) A presence delay is used to determine if Source 2 is a valid source. This delay will start as soon as Source 2 is available. The presence delay is based on the value entered in parameter P07.07 (ATL610) or P09.02.07 (ATL800), default = 10s. If Source 2 is available before Source 1 fails, it is possible that the delay will already be satisfied at the time Source 1 fails. If this is a manual transfer to Source 2 and Source 1 is still available, the presence delay will refer to the value in parameter P07.08 (ATL610) or P09.02.08 (ATL800), default = 60s.
- 6) When the timer in both step 4 and 5 are finished:
 - a. The transfer controller will energize the Source 2 contactor.
 - b. An auxiliary switch NO contact on Source 2's contactor will close, sending a signal to the transfer controller. This signal verifies that the load is connected to Source 2.
 - c. The NC contacts of the same auxiliary switch will open to prevent the coil of Source 1 contactor from energizing.
 - d. The transfer controller will signal the unit is being powered by Source 2.

AUTOMATIC TRANSFER SWITCH

CONTROL MODULE

CHANGE OVER CIRCUIT SEQUENCE OF OPERATIONS

Transfer back to Source 1 when Source 2 is present

- 1) When Source 1 has reached acceptable levels, a presence delay will start. The presence delay is based on the value entered in parameter P06.08 (ATL610) or P09.01.08 (ATL800), default = 60s.
- 2) Once this timer is finished:
 - a. The transfer controller will de-energize Source 2 contactor coil.
 - b. An auxiliary switch NO contact on Source 2's contactor will open, sending a signal to the transfer controller. This signal verifies that the load is not connected to Source 2.
 - c. The NC contacts of the same auxiliary switch will close to allow the coil of the Source 1 contactor to be energized. The Source 1 contactor coil is not energized at this time.
 - d. The transfer controller will signal the unit is no longer being powered by Source 2.
- 3) A delay timer starts using the value in parameter P05.04 (ATL610) or P07.02.02 (ATL800), default = 6s. **This value should not be decreased without consent from Vertiv.**
- 4) When the timer in step 3 is finished:
 - a. The transfer controller will energize the Source 1 contactor.
 - b. An auxiliary switch NO contact on Source 1's contactor will close, sending a signal the transfer controller. This signal verifies that the load is connected to Source 1.
 - c. The NC contacts of the same auxiliary switch will open to prevent the coil of Source 2 contactor from energizing.
 - d. The transfer controller will signal the unit is being powered by Source 1.

AUTOMATIC TRANSFER SWITCH

CONTROL MODULE

CHANGE OVER CIRCUIT SEQUENCE OF OPERATIONS

Source 2 is out of range when unit is powered by Source 2

- 1) Source 2 exceeds one or more limits of voltage, frequency, phase, or voltage symmetry.
- 2) A delay timer will begin to count. The amount of time depends on which Source 2 parameter is out of spec, and the value saved in the following parameters. The parameters below are the delays for each condition.

Description	Default	Parameter	
		ATL610	ATL800
Voltage below the minimum limit	5s	P07.03	P09.02.03
Voltage above the maximum limit	5s	P07.06	P09.02.06
Phase failure	0.1s	P07.10	P09.02.10
Voltage exceeds the asymmetry limits	5s	P07.12	P09.02.12
Frequency exceeds the maximum limit	3s	P07.14	P09.02.14
Frequency exceeds the minimum limit	5s	P07.16	P09.02.16

- 3) Once the delay timer is finished, the following events will occur:
 - a. The transfer controller will de-energize Source 2 contactor coil.
 - b. The transfer controller will signal the unit is no longer being powered by Source 2.
 - c. An auxiliary switch NO contact on Source 2's contactor will open, sending a signal to the transfer controller. This signal verifies that the load is not connected to Source 2.
 - d. The NC contacts of the same auxiliary switch will close to allow the coil of Source 1 contactor to be energized. The Source 1 contactor coil is not energized at this time.
- 4) Once the transfer controller output has opened, a delay timer will begin using the value entered under parameter P05.04 (ATL610) or P07.02.02 (ATL800), default = 6s. This value should not be decreased without consent from Vertiv.
- 5) A presence delay is used to determine if Source 1 is a valid source. This delay will start as soon as Source 1 is available. The presence delay is based on the value entered in parameter P06.07 (ATL610) or P09.01.07 (ATL800), default = 10s. If Source 1 is available before Source 2 fails, it is possible that the delay will already be satisfied at the time Source 2 fails. If this is a manual transfer to Source 1 and Source 2 is still available, the presence delay will refer to the value in parameter P06.08 (ATL610) or P09.01.08 (ATL800), default = 60s.
- 6) When the timer in both steps 4 and 5 are finished:
 - a. The transfer controller will energize the Source 1 contactor.
 - b. An auxiliary switch NO contact on Source 1's contactor will close, sending a signal to the transfer controller. This signal verifies that the load is connected to Source 1.
 - c. The NC contacts of the same auxiliary switch will open to prevent the coil of Source 2 contactor from energizing.
 - d. The transfer controller will signal the unit is being powered by Source 1.

Transfer when Source 1 and Source 2 fails

- 1) If both Source 1 and Source 2 fail and are restored, the transfer controller will transfer the load to the preferred Source defined in parameter P05.02 (ATL610) or P06.01.02/P06.02.02 (ATL800), default = 1.

AUTOMATIC TRANSFER SWITCH

CONTROL MODULE

TRANSFER CONTROLLER TERMINAL LABELS – ATL610

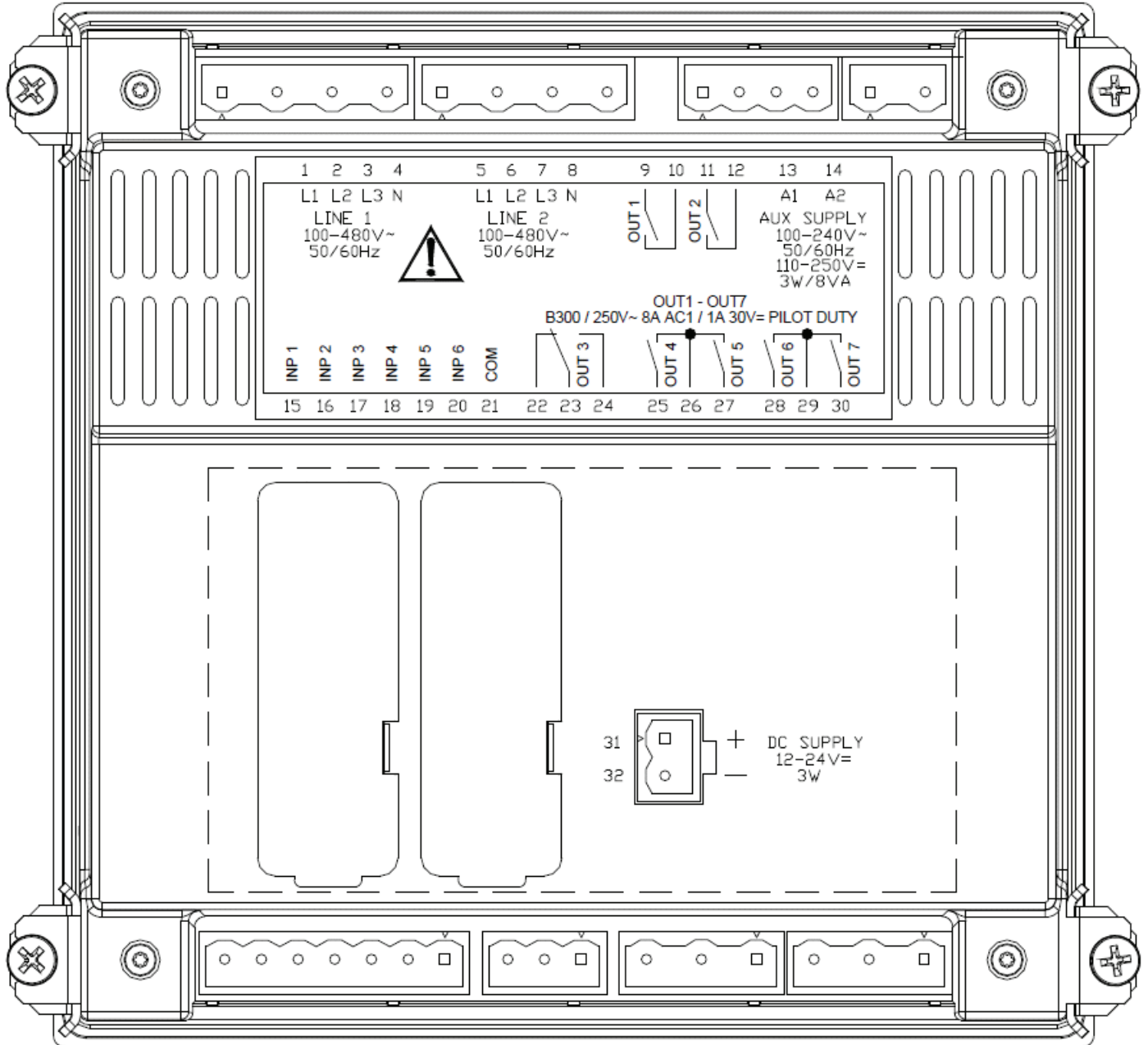



AUTOMATIC TRANSFER SWITCH

CONTROL MODULE

TRANSFER CONTROLLER TERMINAL LABELS – ATL800

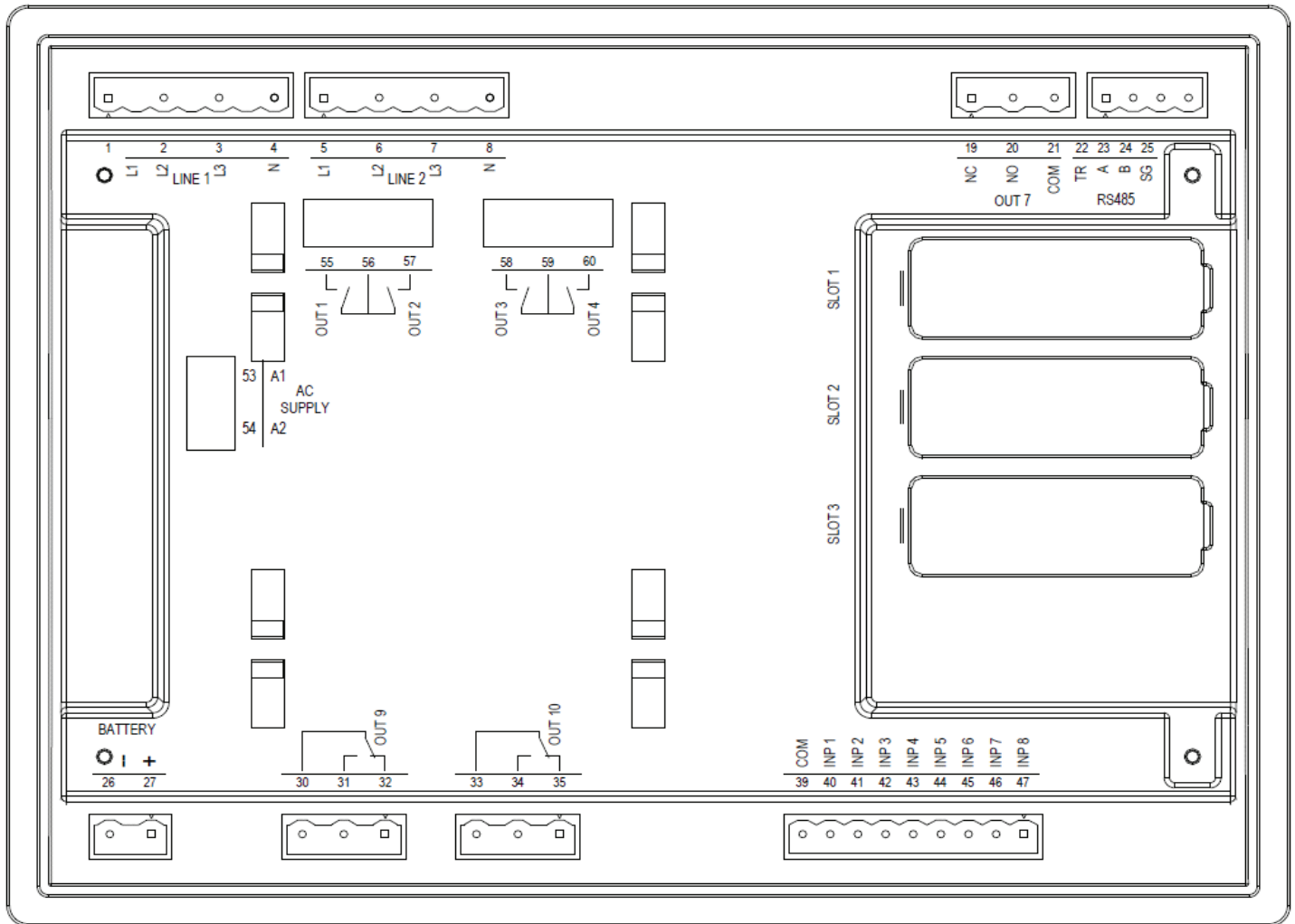



CoolLoop Thermal Wall

THD MITIGATION CA80 HIGH AIRFLOW HIGH EFFICIENCY FAN

IEEE Std 519-2014 defines the maximum voltage distortion limits allowed to be reflected onto the utility distribution system at the point of common coupling (PCC). It is a guideline meant to minimize the effects of electrical pollution created by one utility customer from affecting a different customer.

The guideline requires total voltage harmonic distortion (THD) conform to the limits shown in Table 1.

Table 1 - Voltage distortion limits

Bus voltage V at PCC	Individual Harmonic (%)	Total harmonic distortion THD (%)
V ≤ 1.0 kV^b	5.0	8.0
1 kV < V ≤ 69 kV	3.0	5.0
69 kV < V ≤ 161 kV	1.5	2.5
161 kV < V	1.0	1.5 ^a

^aHigh-voltage systems can have up to 2.0% THD where the cause is an HVDC terminal whose effects will have attenuated at points in the network where future users may be connected.

^bVertiv™ CoolLoop Thermal Wall units fall under the limits for V ≤ 1.0 kV

The individual harmonic current distortion and total current demand distortion (TDD) conform to the limits shown in Table 2.

Table 2 - Current distortion limits for systems rated 120 V through 69 kV

Maximum harmonic current distortion in percent of I _L						
Individual harmonic order (odd harmonics) ^{a,b}						
I _{sc} / I _L	3 ≤ h < 11	11 ≤ h < 17	17 ≤ h < 23	23 ≤ h < 135	35 ≤ h < 50	TDD
< 20 ^c	4.0	2.0	1.5	0.6	0.3	5.0
20 < 50	7.0	3.5	2.5	1.0	0.5	8.0
50 < 100	10.0	4.5	4.0	1.5	0.7	12.0
100 < 1000^d	12.0	5.5	5.0	2.0	1.0	15.0
> 1000	15.0	7.0	6.0	2.5	1.4	20.0

^aEven harmonics are limited to 25% of the odd harmonic limits above.

^bCurrent distortions that result in a dc offset, e.g., half-wave converters, are not allowed.

^cAll power generation equipment is limited to these values of current distortion, regardless of actual I_{sc} / I_L, where

I_{sc} = maximum short-circuit current at PCC (determined by building short circuit analysis)

I_L = maximum demand load current (fundamental frequency component)
at the PCC under normal load operating conditions

^dVertiv™ CoolLoop Thermal Wall units typically fall under the limits for 100 < 1000, assuming I_{sc} ≥ 3,500 amps

It is **NOT** a guideline for individual connected loads, but a guideline for a total building or plant. Many apply the voltage distortion criteria to all substations, and apply the current distortion criteria exclusively to the utility metering point.

Typically, if the variable speed fan load is less than 10% of the current capacity at the point of common coupling (PCC), your installation will meet IEEE-519 guidelines. In this case you should have no interference issues with other electrical equipment. Typically, the worst case PCC is the emergency backup generator plant but could be the transformer which powers the cooling load. If the PCC is a UPS unit, consult your UPS supplier for recommendations. For customers who have variable speed loads that exceed this rule of thumb, it may be necessary to minimize the harmonic impact these variable speed loads have on the system voltage. In these instances, an undesirable effect is a difficulty in switching from generator supply back to utility supply. The purpose of the Vertiv™ CoolLoop Thermal Wall THD mitigation device is to cancel current harmonics generated by the variable frequency drive. This device will not improve harmonics caused by other systems on the power network.



CoolLoop Thermal Wall

THD MITIGATION CA80 HIGH AIRFLOW HIGH EFFICIENCY FAN

Below are the Total Voltage Distortion levels as measured on a single CA80 unit with high airflow, high-efficiency fans. This data is typical of what can be expected in the field. Values may vary depending on operating conditions and on the quality and stability of the electrical supply network.

Typical Total Voltage Distortion for CA80 with High Airflow, High Efficiency Fans at 460 Volts:

Voltage Harmonic List — 100% Fan Speed

Without Mitigation Device						
Order	L1		L2		L3	
	Volts	%Distortion	Volts	%Distortion	Volts	%Distortion
1	475.85		474.21		473.43	
5	4.35	0.91%	4.15	0.87%	4.86	1.03%
7	7.51	1.58%	6.24	1.32%	6.54	1.38%
11	4.66	0.98%	4.62	0.97%	4.95	1.04%
13	1.82	0.38%	1.72	0.36%	2.27	0.48%
17	3.93	0.82%	4.11	0.87%	4.10	0.87%
Total THD (%)	2.81%		2.71%		2.76%	
With Mitigation Device						
Order	L1		L2		L3	
	Volts	%Distortion	Volts	%Distortion	Volts	%Distortion
1	473.94		473.88		473.31	
5	4.23	0.89%	3.67	0.78%	4.44	0.94%
7	6.17	1.30%	5.24	1.11%	5.18	1.10%
11	3.67	0.77%	3.64	0.77%	4.00	0.85%
13	0.78	0.17%	0.87	0.18%	1.08	0.23%
17	2.44	0.52%	2.50	0.53%	2.44	0.52%
Total THD (%)	2.47%		2.48%		2.37%	

Voltage Harmonic List — 50% Fan Speed

Without Mitigation Device						
Order	L1		L2		L3	
	Volts	%Distortion	Volts	%Distortion	Volts	%Distortion
1	478.98		474.86		476.71	
5	3.14	0.66%	3.05	0.64%	3.67	0.77%
7	5.46	1.14%	4.18	0.88%	4.13	0.87%
11	1.56	0.33%	1.28	0.27%	1.64	0.34%
13	0.98	0.21%	0.76	0.16%	0.88	0.18%
17	0.29	0.06%	0.11	0.02%	0.20	0.04%
Total THD (%)	2.01%		1.91%		1.88%	
With Mitigation Device						
Order	L1		L2		L3	
	Volts	%Distortion	Volts	%Distortion	Volts	%Distortion
1	474.29		474.83		475.18	
5	2.67	0.56%	2.54	0.54%	3.25	0.68%
7	4.56	0.96%	3.61	0.76%	3.50	0.74%
11	1.78	0.38%	1.89	0.40%	2.20	0.46%
13	0.67	0.14%	0.52	0.11%	0.61	0.13%
17	0.59	0.12%	0.45	0.09%	0.55	0.11%
Total THD (%)	1.94%		2.01%		1.86%	



CoolLoop Thermal Wall

THD MITIGATION CA80 HIGH AIRFLOW HIGH EFFICIENCY FAN

Below are the Total Current Distortion levels as measured on a single CA80 unit with high airflow, high efficiency fans. This data is typical of what can be expected in the field. Values may vary depending on operating conditions and on the quality and stability of the electrical supply network.

Typical Total Current Distortion for CA80 with High Airflow, High Efficiency Fans at 460 Volts:

Current Harmonic List — 100% Fan Speed

Without Mitigation Device						
Order	L1		L2		L3	
	amps	% Distortion	amps	% Distortion	amps	% Distortion
1	33.03		32.76		33.12	
5	8.12	24.59%	8.16	24.90%	8.23	24.84%
7	8.66	26.22%	8.27	25.25%	8.70	26.26%
11	5.68	17.20%	5.79	17.66%	5.89	17.77%
13	4.53	13.72%	3.85	11.75%	4.37	13.18%
17	5.51	16.69%	5.75	17.55%	5.79	17.49%
Total THD (%)	46.62%		46.12%		47.25%	
With Mitigation Device						
Order	L1		L2		L3	
	amps	% Distortion	amps	% Distortion	amps	% Distortion
1	30.39		29.93		30.37	
5	1.10	3.61%	0.77	2.58%	1.05	3.47%
7	0.72	2.36%	0.65	2.16%	0.56	1.86%
11	0.56	1.84%	0.62	2.07%	0.53	1.74%
13	0.36	1.20%	0.35	1.16%	0.35	1.16%
17	0.02	0.05%	0.01	0.02%	0.02	0.06%
Total THD (%)	4.95%		4.31%		4.66%	

Current Harmonic List — 50% Fan Speed

Without Mitigation Device						
Order	L1		L2		L3	
	amps	% Distortion	amps	% Distortion	amps	% Distortion
1	8.53		8.08		8.60	
5	6.00	70.28%	5.77	71.45%	6.03	70.15%
7	4.99	58.53%	4.83	59.77%	5.36	62.32%
11	2.72	31.89%	2.71	33.58%	2.72	31.57%
13	1.64	19.20%	1.82	22.47%	1.89	21.96%
17	2.15	25.22%	2.05	25.31%	1.74	20.22%
Total THD (%)	119.97%		121.86%		123.98%	
With Mitigation Device						
Order	L1		L2		L3	
	amps	% Distortion	amps	% Distortion	amps	% Distortion
1	9.96		9.89		9.76	
5	0.43	4.35%	0.32	3.22%	0.43	4.38%
7	0.64	6.45%	0.66	6.72%	0.67	6.82%
11	0.32	3.17%	0.32	3.27%	0.32	3.27%
13	0.09	0.95%	0.10	0.99%	0.10	1.01%
17	0.04	0.39%	0.04	0.39%	0.03	0.35%
Total THD (%)	9.06%		8.88%		9.39%	

NOTE: Values shown at 50% fan speed are for reference only. At low demand, THD values will have a lower impact on the system than at full load.



CoolLoop Thermal Wall

THD MITIGATION CA80 ULTRA PERFORMANCE FAN

IEEE Std 519-2014 defines the maximum voltage distortion limits allowed to be reflected onto the utility distribution system at the point of common coupling (PCC). It is a guideline meant to minimize the effects of electrical pollution created by one utility customer from affecting a different customer.

The guideline requires total voltage harmonic distortion (THD) conform to the limits shown in Table 1.

Table 1 - Voltage distortion limits

Bus voltage V at PCC	Individual Harmonic (%)	Total harmonic distortion THD (%)
$V \leq 1.0 \text{ kV}^b$	5.0	8.0
$1 \text{ kV} < V \leq 69 \text{ kV}$	3.0	5.0
$69 \text{ kV} < V \leq 161 \text{ kV}$	1.5	2.5
$161 \text{ kV} < V$	1.0	1.5 ^a

^aHigh-voltage systems can have up to 2.0% THD where the cause is an HVDC terminal whose effects will have attenuated at points in the network where future users may be connected.

^bVertiv™ CoolLoop Thermal Wall units fall under the limits for $V \leq 1.0 \text{ kV}$

The individual harmonic current distortion and total current demand distortion (TDD) conform to the limits shown in Table 2.

Table 2 - Current distortion limits for systems rated 120 V through 69 kV

Maximum harmonic current distortion in percent of I_L						
Individual harmonic order (odd harmonics) ^{a,b}						
I_{sc} / I_L	$3 \leq h < 11$	$11 \leq h < 17$	$17 \leq h < 23$	$23 \leq h < 135$	$35 \leq h < 50$	TDD
$< 20^c$	4.0	2.0	1.5	0.6	0.3	5.0
$20 < 50$	7.0	3.5	2.5	1.0	0.5	8.0
$50 < 100$	10.0	4.5	4.0	1.5	0.7	12.0
$100 < 1000^d$	12.0	5.5	5.0	2.0	1.0	15.0
> 1000	15.0	7.0	6.0	2.5	1.4	20.0

^aEven harmonics are limited to 25% of the odd harmonic limits above.

^bCurrent distortions that result in a dc offset, e.g., half-wave converters, are not allowed.

^cAll power generation equipment is limited to these values of current distortion, regardless of actual I_{sc} / I_L .

where

I_{sc} = maximum short-circuit current at PCC (determined by building short circuit analysis)

I_L = maximum demand load current (fundamental frequency component)

at the PCC under normal load operating conditions

^dVertiv™ CoolLoop Thermal Wall units typically fall under the limits for $100 < 1000$, assuming $I_{sc} \geq 3,500$ amps

It is **NOT** a guideline for individual connected loads, but a guideline for a total building or plant. Many apply the voltage distortion criteria to all substations, and apply the current distortion criteria exclusively to the utility metering point.

Typically, if the variable speed fan load is less than 10% of the current capacity at the point of common coupling (PCC), your installation will meet IEEE-519 guidelines. In this case you should have no interference issues with other electrical equipment. Typically, the worst case PCC is the emergency backup generator plant but could be the transformer which powers the cooling load. If the PCC is a UPS unit, consult your UPS supplier for recommendations. For customers who have variable speed loads that exceed this rule of thumb, it may be necessary to minimize the harmonic impact these variable speed loads have on the system voltage. In these instances, an undesirable effect is a difficulty in switching from generator supply back to utility supply. The purpose of the Vertiv™ CoolLoop Thermal Wall THD mitigation device is to cancel current harmonics generated by the variable frequency drive. This device will not improve harmonics caused by other systems on the power network.



CoolLoop Thermal Wall

THD MITIGATION CA80 ULTRA PERFORMANCE FAN

Below are the Total Voltage Distortion levels as measured on a single CA80 unit with ultra performance fans. This data is typical of what can be expected in the field. Values may vary depending on operating conditions and on the quality and stability of the electrical supply network.

Typical Total Voltage Distortion for CA80 with Ultra Performance Fans at 460 Volts:

Voltage Harmonic List — 100% Fan Speed

Without Mitigation Device						
Order	L1		L2		L3	
	Volts	% Distortion	Volts	% Distortion	Volts	% Distortion
1	474.32		474.35		479.77	
5	11.57	2.44%	11.76	2.48%	15.11	3.15%
7	3.46	0.73%	4.36	0.92%	6.96	1.45%
11	3.04	0.64%	2.99	0.63%	1.49	0.31%
13	3.79	0.80%	4.36	0.92%	3.65	0.76%
17	2.23	0.47%	2.13	0.45%	3.69	0.77%
Total THD (%)		3.22%		3.59%		4.08%

With Mitigation Device						
Order	L1		L2		L3	
	Volts	% Distortion	Volts	% Distortion	Volts	% Distortion
1	479.08		481.36		476.11	
5	4.07	0.85%	3.03	0.63%	2.90	0.61%
7	1.34	0.28%	1.49	0.31%	1.81	0.38%
11	1.34	0.28%	7.85	1.63%	6.90	1.45%
13	1.15	0.24%	1.88	0.39%	1.24	0.26%
17	1.39	0.29%	1.25	0.26%	1.19	0.25%
Total THD (%)		1.15%		2.00%		1.84%

Voltage Harmonic List — 50% Fan Speed

Without Mitigation Device						
Order	L1		L2		L3	
	Volts	% Distortion	Volts	% Distortion	Volts	% Distortion
1	477.40		478.86		479.78	
5	9.93	2.08%	11.73	2.45%	13.21	2.73%
7	4.06	0.85%	2.25	0.47%	4.69	0.97%
11	2.48	0.52%	0.53	0.11%	1.94	0.40%
13	2.24	0.47%	2.30	0.48%	2.81	0.58%
17	2.34	0.49%	1.68	0.35%	1.94	0.40%
Total THD (%)		2.60%		2.84%		3.16%

With Mitigation Device						
Order	L1		L2		L3	
	Volts	% Distortion	Volts	% Distortion	Volts	% Distortion
1	480.71		482.34		480.74	
5	2.88	0.60%	2.70	0.56%	2.98	0.62%
7	1.87	0.39%	1.74	0.36%	2.07	0.43%
11	1.73	0.36%	3.33	0.69%	3.22	0.67%
13	5.10	1.06%	8.78	1.82%	3.70	0.77%
17	1.01	0.21%	1.69	0.35%	1.49	0.31%
Total THD (%)		2.06%		2.41%		1.40%



CoolLoop Thermal Wall

THD MITIGATION CA80 ULTRA PERFORMANCE FAN

Below are the Total Current Distortion levels as measured on a single CA80 unit with ultra performance fans. This data is typical of what can be expected in the field. Values may vary depending on operating conditions and on the quality and stability of the electrical supply network.

Typical Total Current Distortion for CA80 with Ultra Performance Fans at 460 Volts:

Current Harmonic List — 100% Fan Speed

Without Mitigation Device						
Order	L1		L2		L3	
	amps	% Distortion	amps	% Distortion	amps	% Distortion
1	42.43		42.30		48.09	
5	8.14	19.18%	8.12	19.20%	8.53	20.27%
7	8.08	19.04%	8.87	20.98%	9.07	21.54%
11	4.06	9.57%	3.65	8.62%	3.81	9.05%
13	4.63	10.91%	5.13	12.13%	4.68	11.11%
17	3.45	8.13%	2.43	5.75%	2.91	6.91%
Total THD (%)	34.82%		35.97%		37.44%	
With Mitigation Device						
Order	L1		L2		L3	
	amps	% Distortion	amps	% Distortion	amps	% Distortion
1	41.20		40.40		41.30	
5	1.69	4.09%	1.64	4.07%	1.63	3.95%
7	0.16	0.39%	0.66	1.63%	0.80	1.93%
11	0.44	1.07%	0.12	0.30%	0.34	0.82%
13	0.39	0.94%	0.11	0.28%	0.45	1.09%
17	0.63	1.53%	0.40	0.98%	0.42	1.01%
Total THD (%)	4.83%		4.78%		4.96%	

Current Harmonic List — 50% Fan Speed

Without Mitigation Device						
Order	L1		L2		L3	
	amps	% Distortion	amps	% Distortion	amps	% Distortion
1	8.40		8.00		8.00	
5	4.36	51.96%	4.46	55.76%	4.63	57.87%
7	2.33	27.73%	2.17	27.15%	2.43	30.37%
11	1.62	19.24%	1.32	16.47%	1.65	20.60%
13	1.89	22.53%	1.80	22.54%	1.91	23.93%
17	1.54	18.30%	1.60	19.95%	1.31	16.43%
Total THD (%)	80.18%		84.11%		88.62%	
With Mitigation Device						
Order	L1		L2		L3	
	amps	% Distortion	amps	% Distortion	amps	% Distortion
1	10.80		10.80		11.20	
5	1.09	10.07%	1.15	10.63%	1.27	11.36%
7	0.44	4.03%	0.30	2.80%	0.18	1.61%
11	0.43	3.95%	0.11	1.04%	0.37	3.32%
13	0.13	1.17%	0.31	2.86%	0.28	2.46%
17	0.26	2.39%	0.13	1.21%	0.16	1.43%
Total THD (%)	16.30%		15.84%		15.37%	

NOTE: Values shown at 50% fan speed are for reference only. At low demand, THD values will have a lower impact on the system than at full load.

UNIT TO UNIT NETWORK CONNECTIONS FOR CoolPhase Perimeter, CoolLoop Perimeter and CoolLoop Thermal Wall

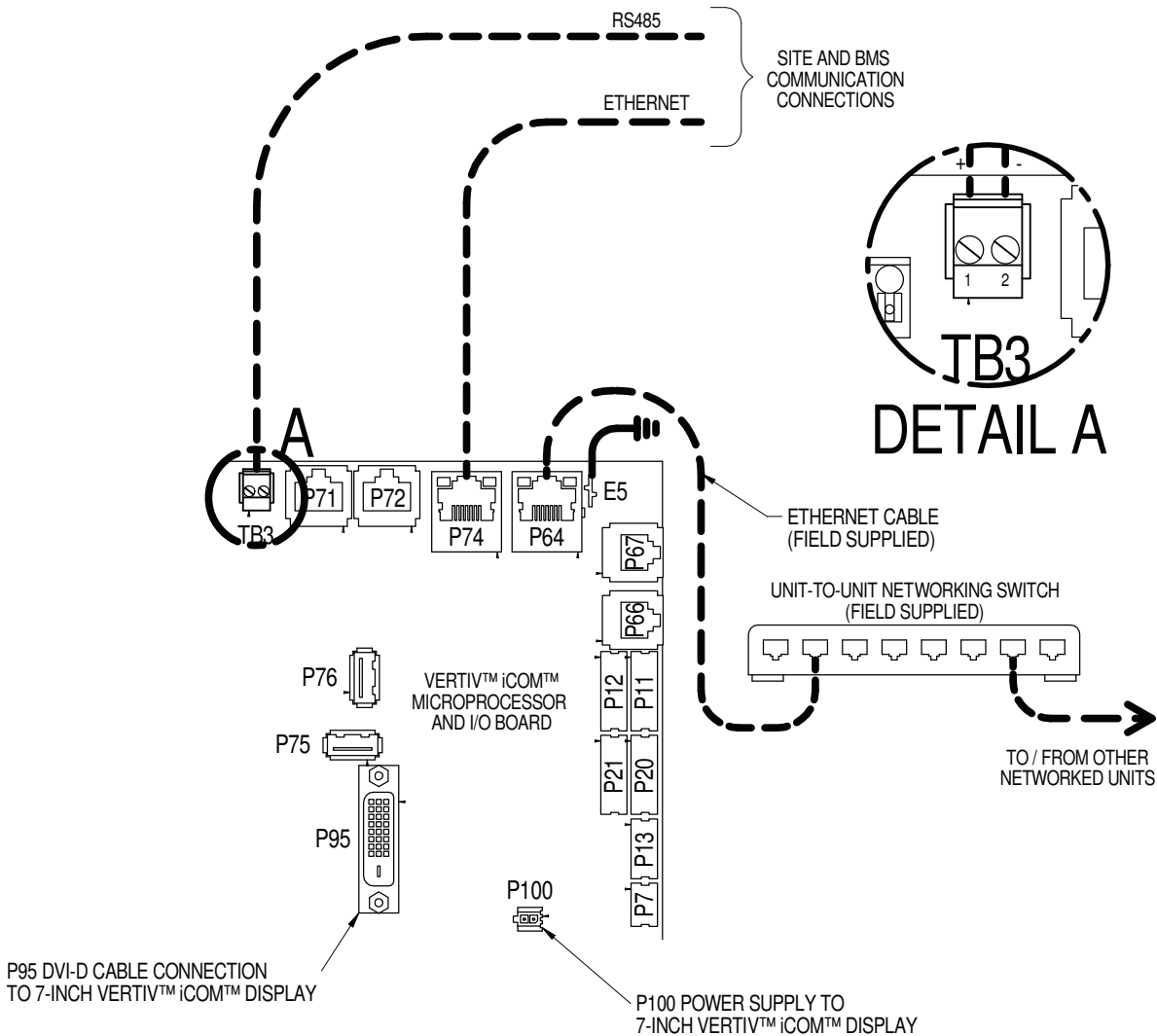

UNIT TO UNIT NETWORK CONNECTIONS FOR CoolPhase Perimeter, CoolLoop Perimeter and CoolLoop Thermal Wall

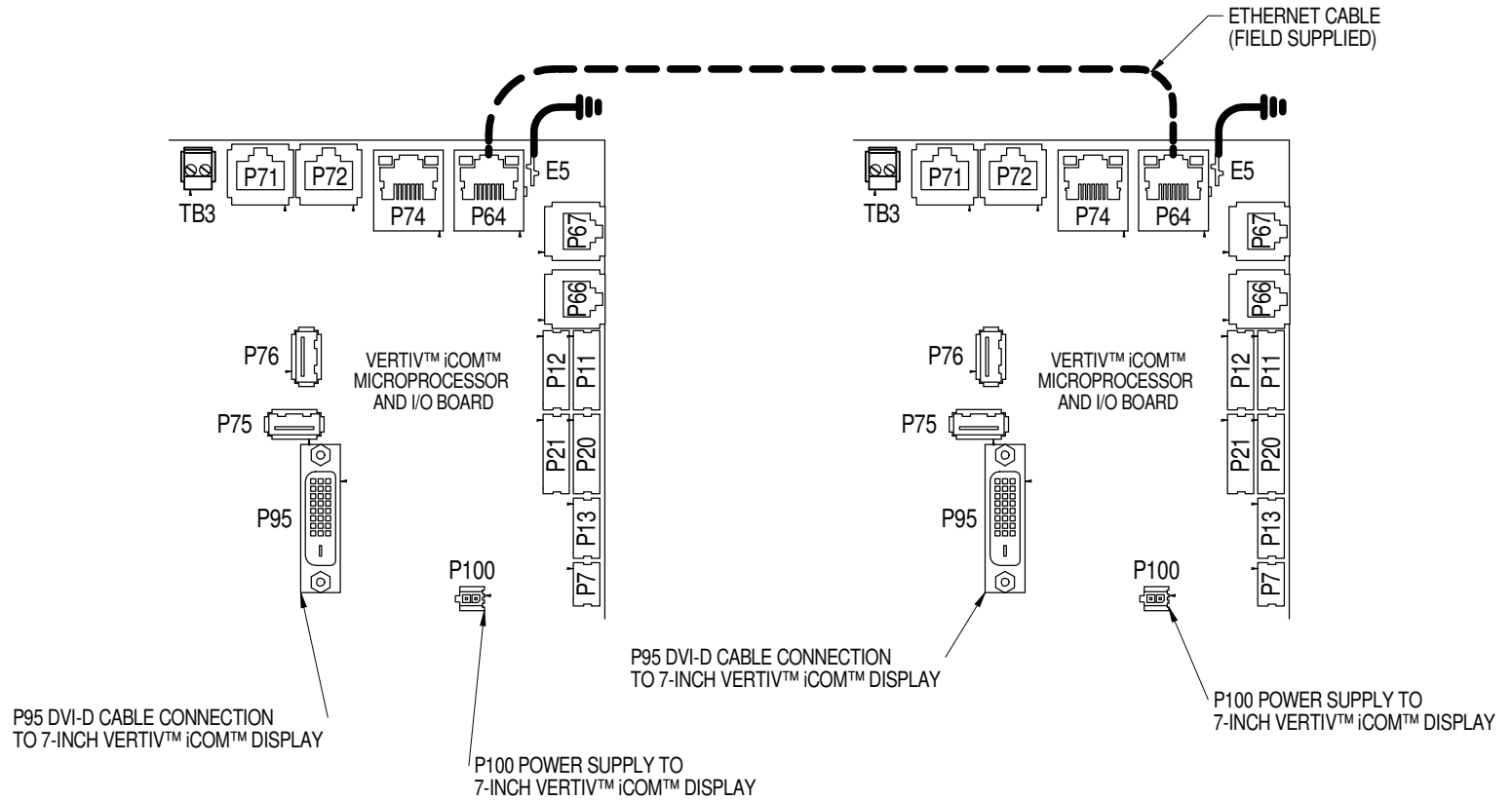

NOTE* For dual-unit network configurations only

CA80 RETURN AND SUPPLY SENSORS LOCATION

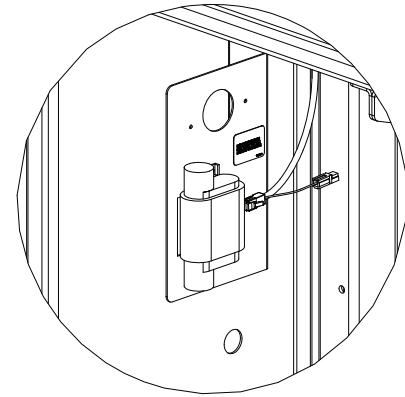
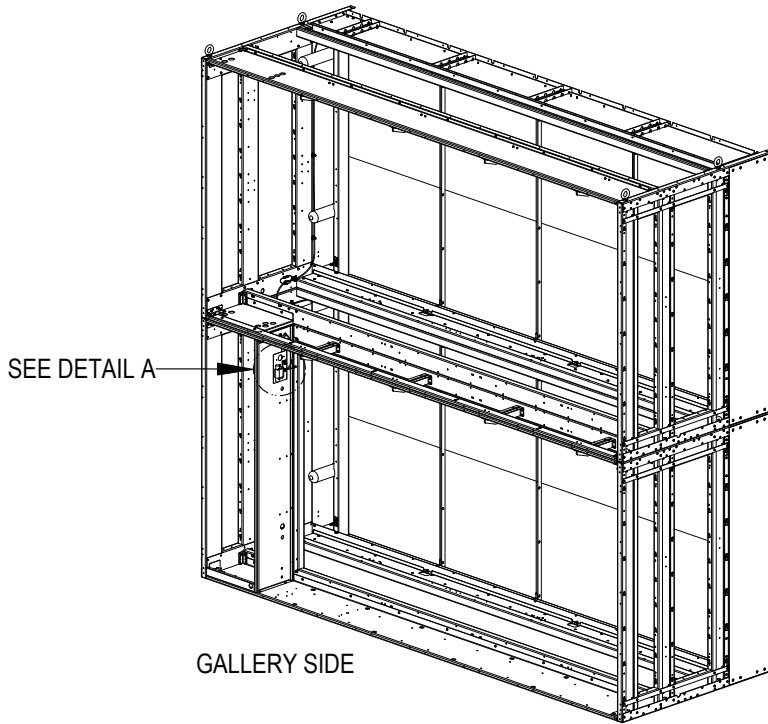

DETAIL A
Temperature and Humidity
Sensor

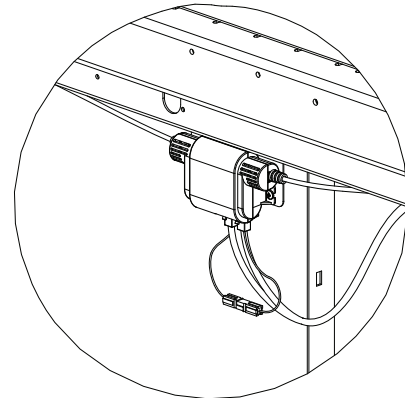
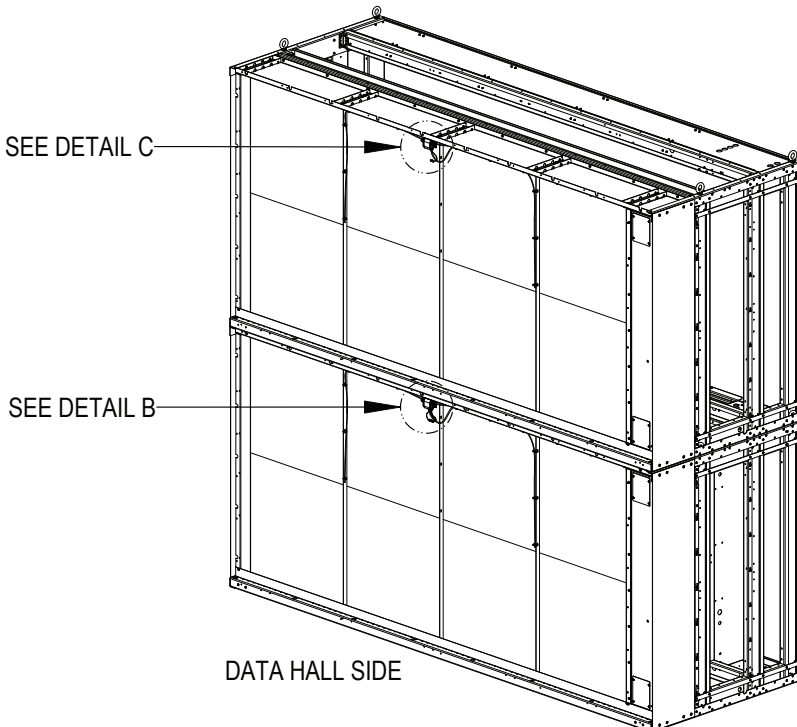

DETAIL B
Supply Air Sensor
(Bottom Module)

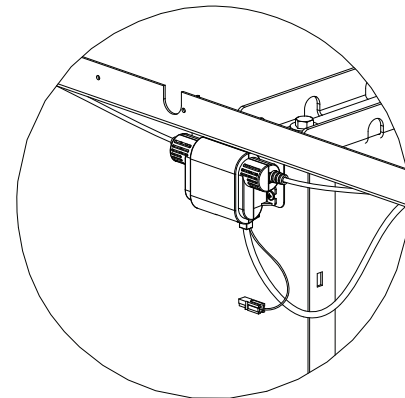

DETAIL C
Supply Air Sensor
(Top Module)

Note: Some items not shown for clarity

CoolLoop Thermal Wall

CA80 SUPPLY AIR SENSORS FIELD CONNECTION

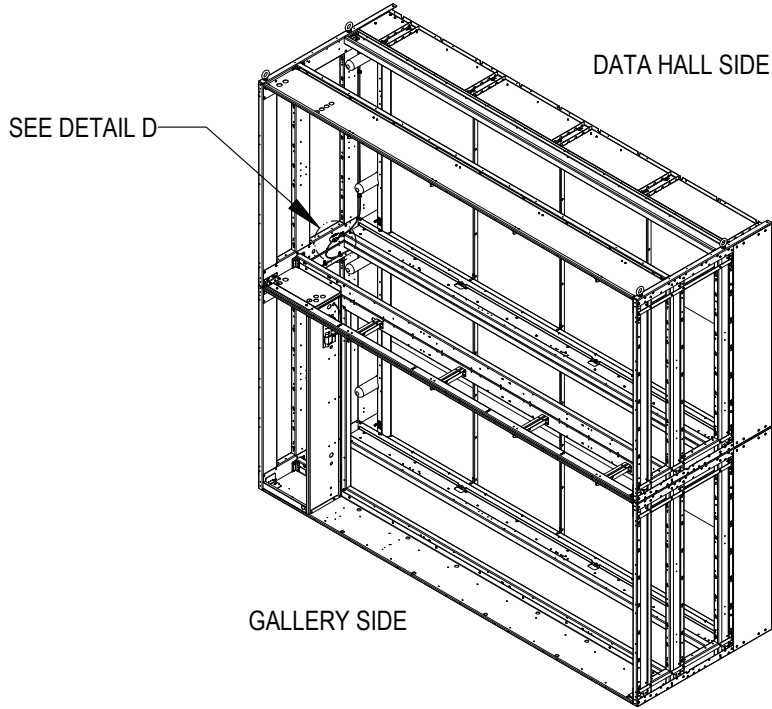

Important

After having installed the top module of the unit, the supply air sensors must be interconnected; to connect the signal and ground wires (SEE DETAIL D).

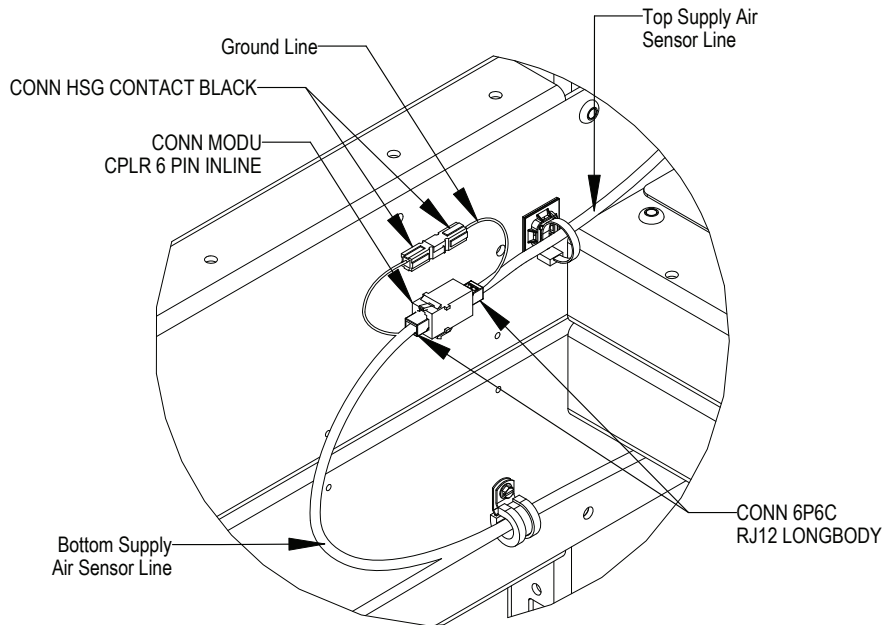

DETAIL D
Supply Air Sensors Interconnection
(Bottom and Top)

Notes:

1. Some items not shown for clarity.
2. Remove lateral panel for easier installation.

CoolLoop Thermal Wall

INLET/OUTLET WATER TEMPERATURE SENSOR LOCATION (OPTIONAL)

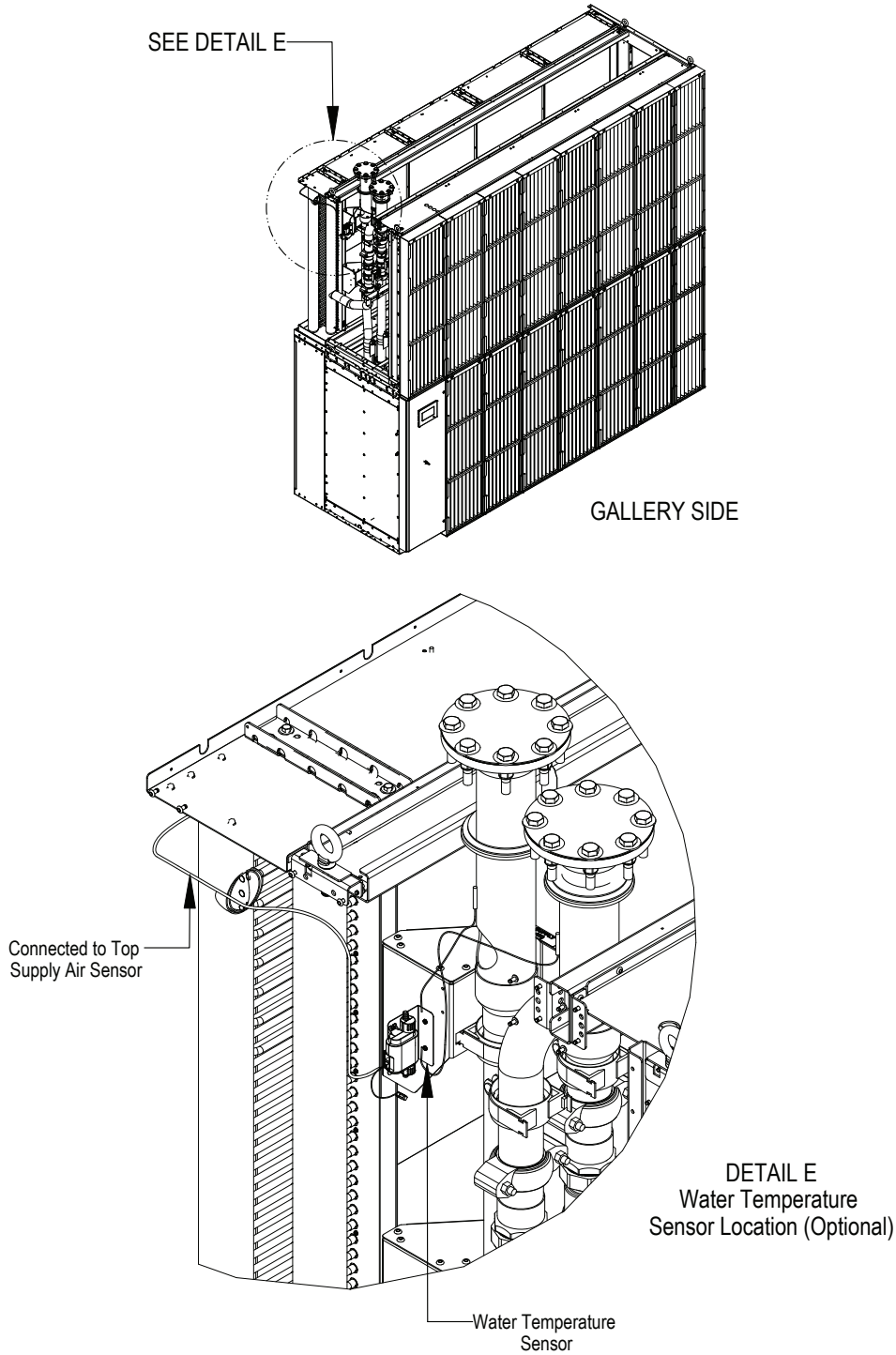

Notes:

1. Some items not shown for clarity.
2. Water Temperature Sensor is optional.

2T RACK TEMPERATURE SENSOR CONNECTIONS FOR CoolPhase Perimeter, CoolLoop Perimeter and CoolLoop Thermal Wall

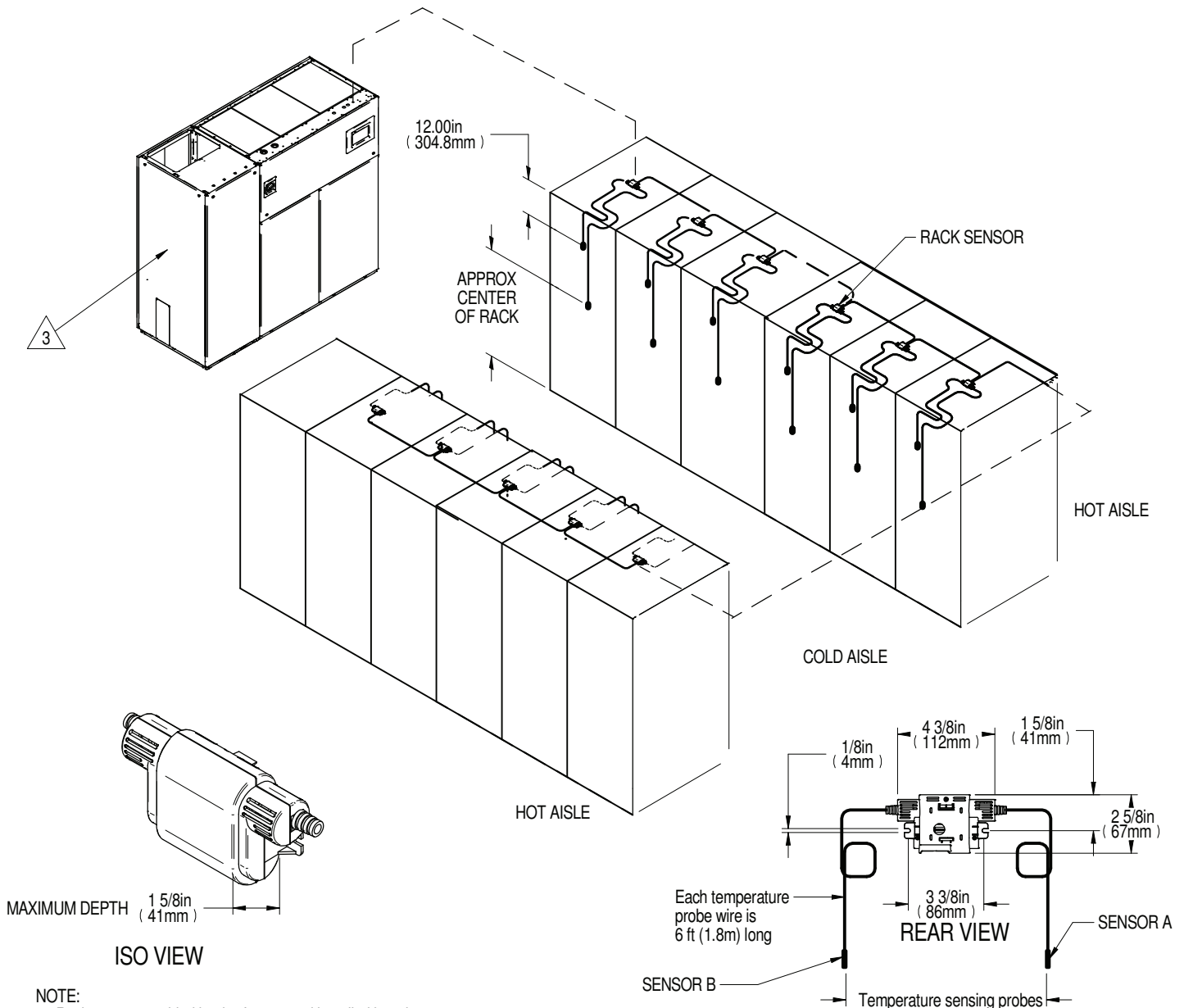

NOTE:

1. Rack sensor provided by the factory and installed by others.
2. Install temperature sensors on the perforated portion of the rack door using the supplied wire ties. Ensure door can swing open freely without binding cables.
3. The cooling unit used in this submittal drawing is a reference model, it's only purpose is to show how a 2T sensor system can be laid out.
4. The low voltage electrical knockout locations will vary between Vertiv™ units.
5. All the low voltage internal component orientations and positioning will vary.

RECOMMENDED WIRED SENSOR LOCATIONS

1. Racks at end of aisles/rows shall be monitored via wired/wireless temperature sensors.
2. At minimum 1 of every 3 racks should be monitored, equally spaced if populated racks exist.

SEE INSTRUCTION SHEET 310301 FOR CANBUS WIRE CONSIDERATIONS AND SENSOR INSTALLATION INSTRUCTIONS.

REMOTE TEMPERATURE & HUMIDITY SENSOR

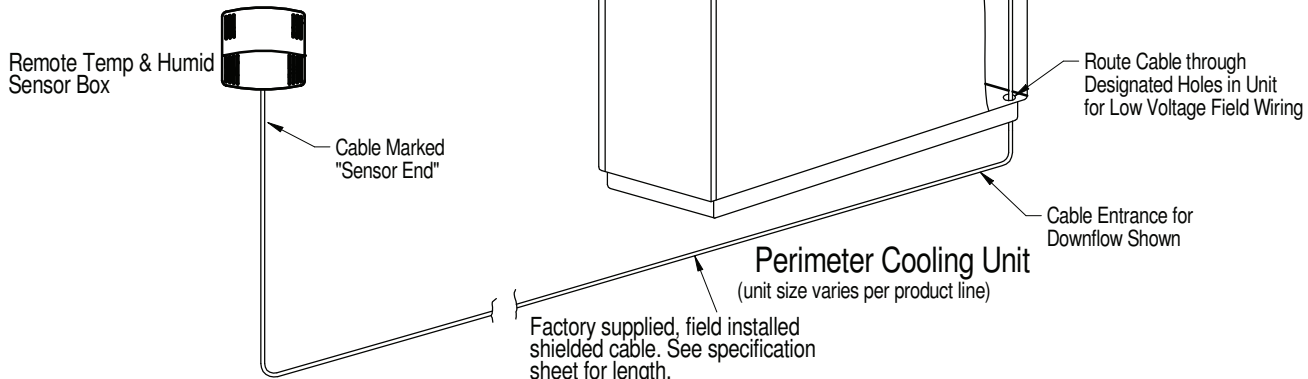
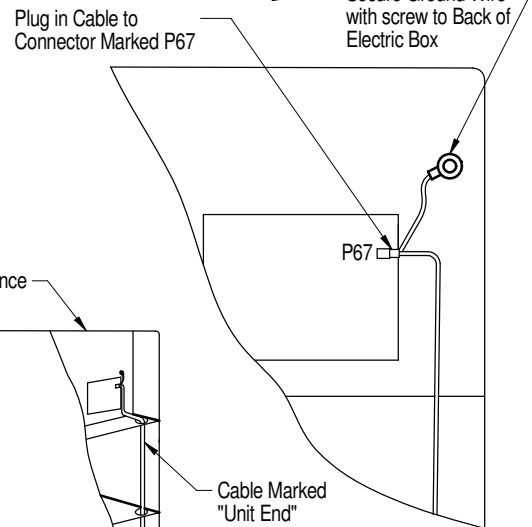
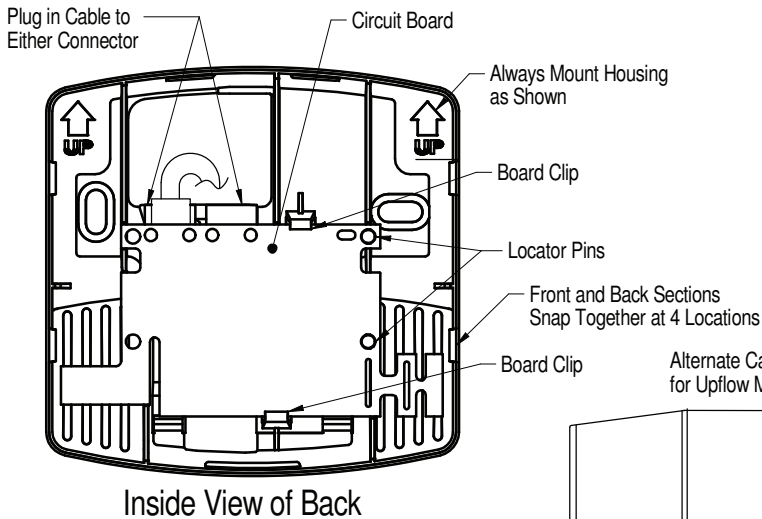
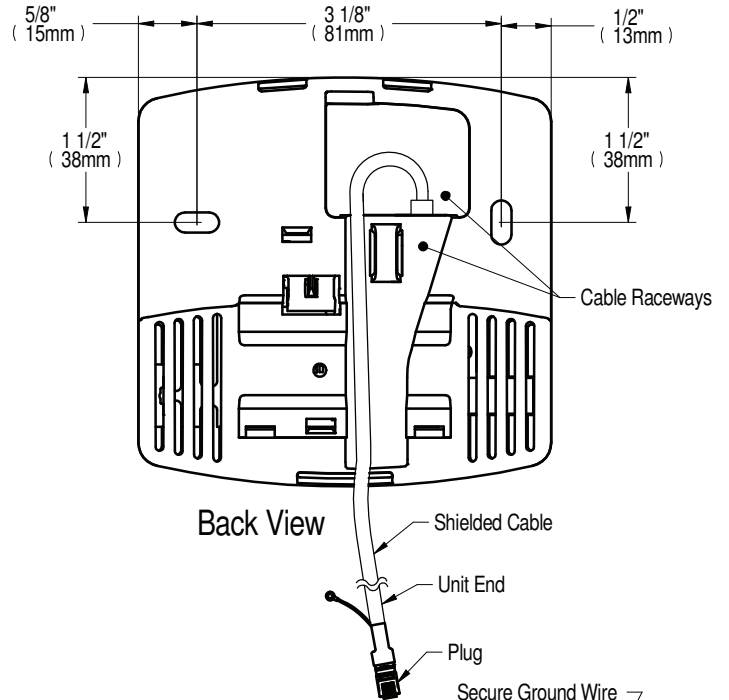
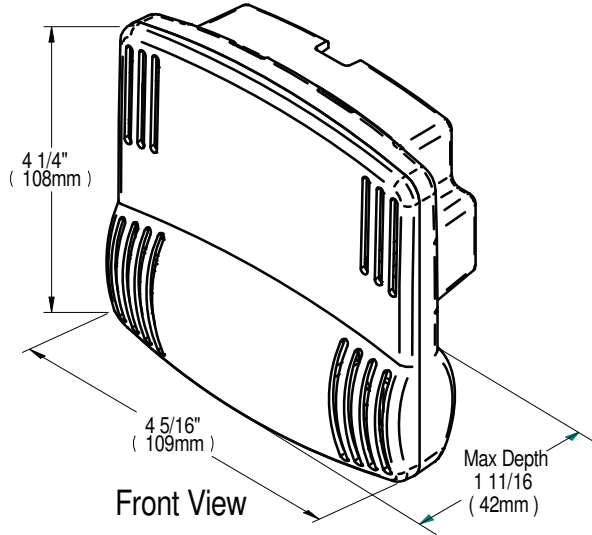

CA80 TOP AND BOTTOM ASSEMBLY INTERNAL CONDENSATE DRAIN LINE CONNECTION

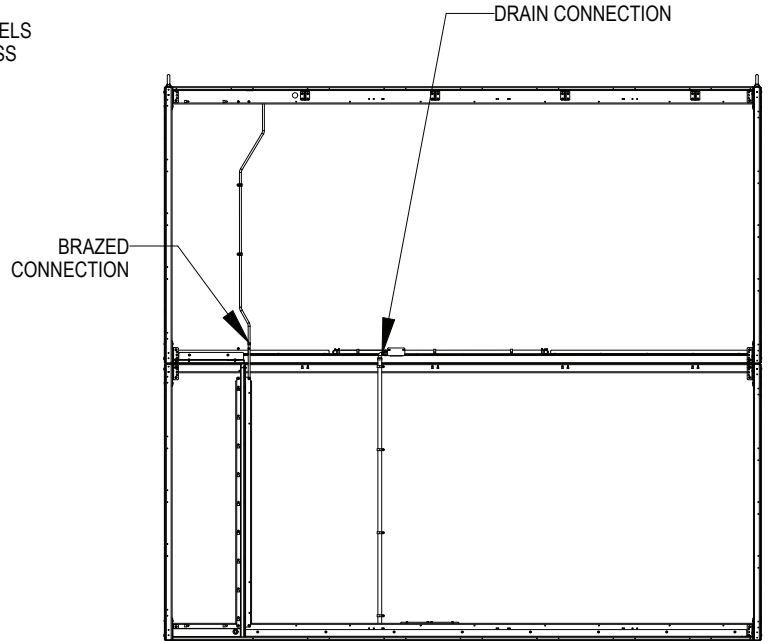
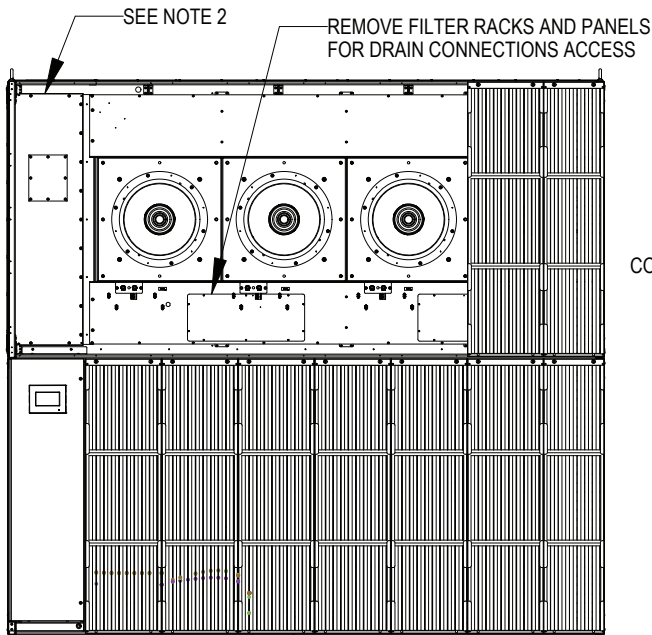

DRAIN LINE ROUTING
FRAME SHOWN FOR REFERENCE. SOME MEMBERS HIDDEN FOR CLARITY

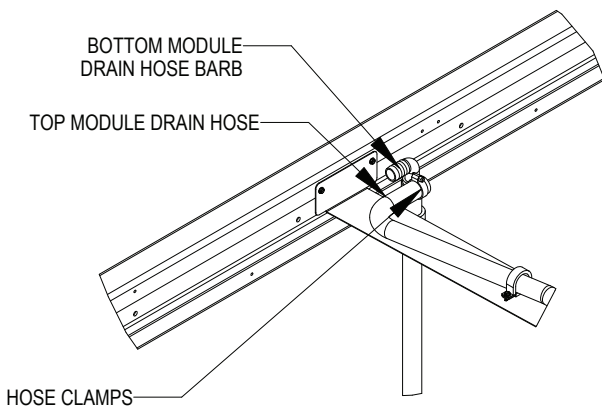

INTERNAL DRAIN CONNECTION
SEE NOTE 1 FOR DRAIN CONNECTION DETAILS

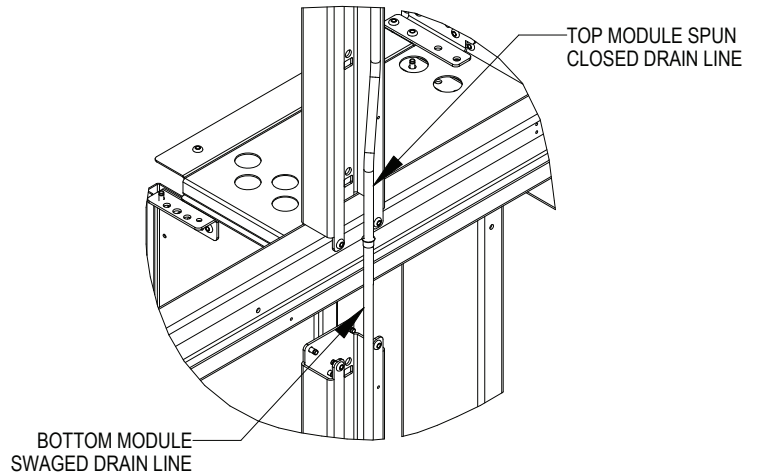

INTERNAL BRAZED CONNECTION FOR CONDENSATE PUMPS
SEE NOTE 3 FOR DRAIN CONNECTION DETAILS

NOTES:

1. REQUIRED FOR GRAVITY DRAIN AND CONDENSATE PUMP. INTERNAL CONNECTION MUST BE MADE BETWEEN TOP AND BOTTOM DRAIN HOSES. CUT HOSE TO LENGTH ON TOP MODULE AND ADJUST HOSE CLAMPS TO ENSURE PROPER SLOPE FOR DRAINAGE.
2. FOR CONDENSATE PUMP ONLY. REMOVE PANEL TO ACCESS BRAZED COPPER DRAIN CONNECTION.
3. REMOVE EXCESS COPPER ON SPUN CLOSED TOP MODULE DRAIN LINE. REMOVE PLUG ON BOTTOM MODULE COPPER DRAIN LINE. ENSURE COPPER IS CLEAN BEFORE BRAZING INTERNAL CONNECTION.

CA80 FIELD GRAVITY DRAIN CONNECTION

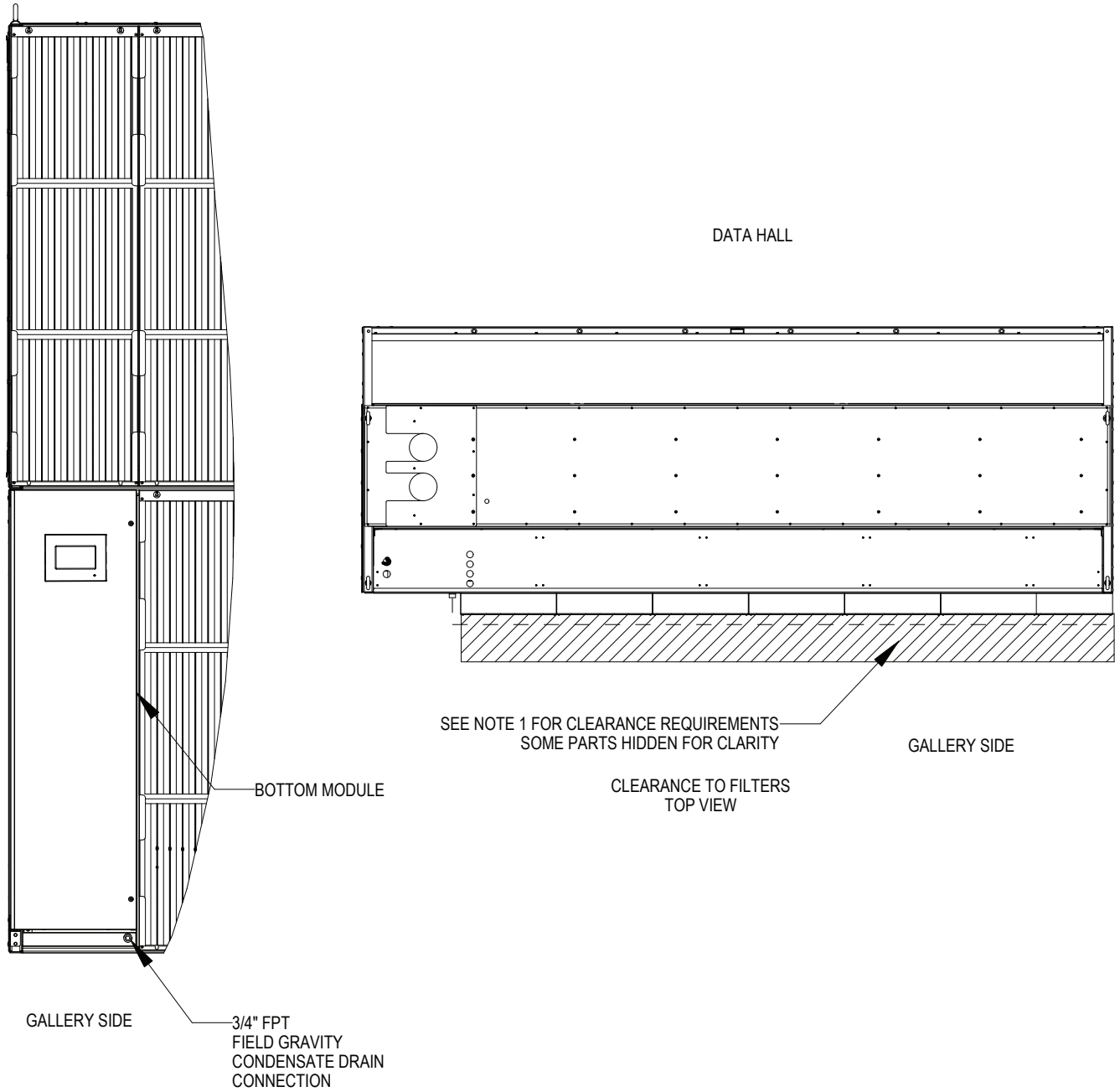

NOTES:
1. FOR EXTERNAL DRAIN CONNECTION ROUTED IN FRONT OF FILTERS, 4.00" [101.6mm] MINIMUM CLEARANCE REQUIRED.



CoolLoop Thermal Wall

CA80 BACKDRAFT BARRIER PLATE KIT High Airflow/High Efficiency Fan

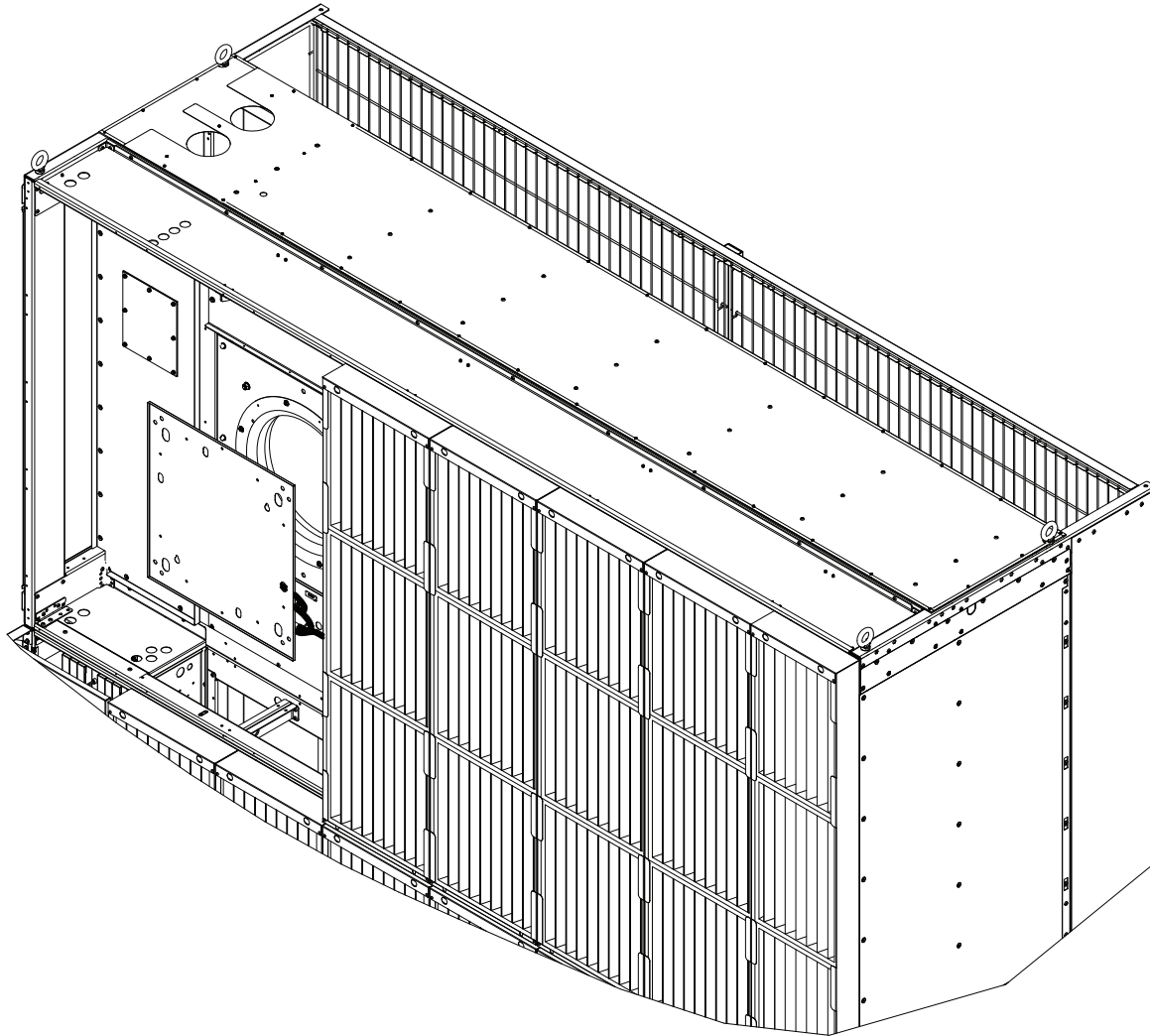

Note:

1. Backdraft Barrier Plate Kit for the High Airflow/High Efficiency fans shall be used to block airflow for unit or fan not in operation. Kit includes four plates
Multiple quantities may be ordered per desired application.



CoolLoop Thermal Wall

CA80 BACKDRAFT BARRIER PLATE KIT ULTRA PERFORMANCE FAN

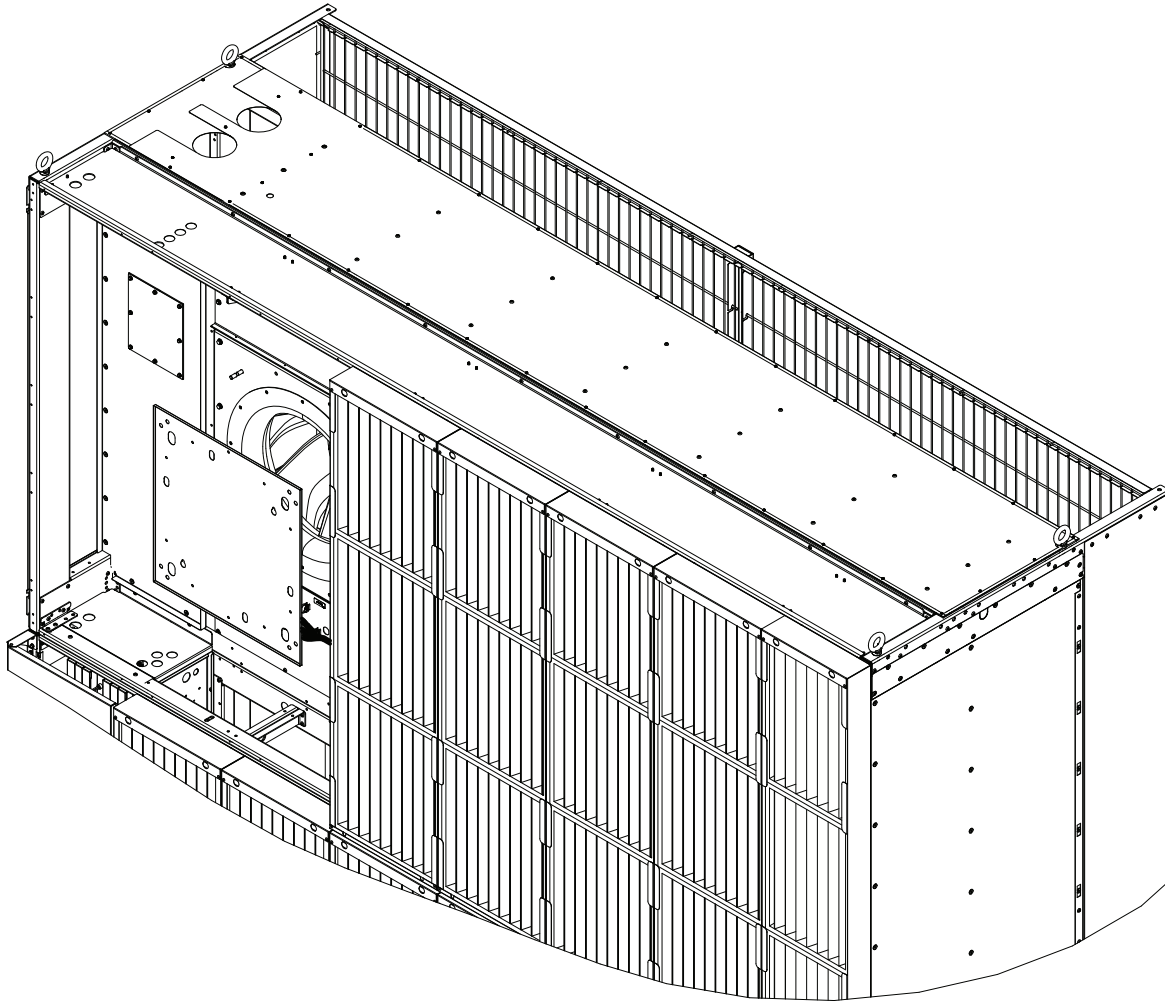

Note:

1. Backdraft Barrier Plate Kit for the Ultra fans shall be used to block airflow for unit or fan not in operation. Kit includes four plates
Multiple quantities may be ordered per desired application.

Appendix D: Seismic Application

Certification	IBC	
Internal Bracing Option	Factory Installed	
Unit	Sds	Ip
CA060 (Top and Bottom Module)	0.75 or 2.5	1.0
CA080 (Top and Bottom Module)	0.75 or 2.5	1.0

This page intentionally left blank

Appendix E: Guide Specifications

The following are the guide specifications for Vertiv™ CoolLoop Thermal Wall.

Vertiv™ CoolLoop Thermal Wall Guide Specifications

1.0 GENERAL

1.1 Summary

These specifications describe requirements for a Thermal Management system. The system shall be designed to control temperature in rooms containing electronic equipment, with good insulation and vapor barrier. The manufacturer shall design and furnish all equipment to be fully compatible with heat dissipation requirements of the room.

1.2 Design Requirements

The Thermal Management system shall be a Vertiv™ self-contained, factory assembled unit. Standard 60 Hz units shall conform to UL STD 60335-2-40, 60335-1, certified to CSA STD C22.2#60335-2-40, 60335-1, and are marked with the cETLus Listed logo, control number 88980.

1.3 Submittals

Submittals shall be provided with the agreement of the proposal and shall include: Single Line Diagrams; Dimensional, Electrical and Capacity Data; Piping; and Electrical Connection Drawings.

1.4 Serviceability/Access

All service and maintenance shall be performed through the Gallery side of the unit, including any component removal (except the chilled water coil). No side access shall be required. All electrical and piping connections are made through the top of the unit.

1.5 Acceptable Alternatives

Acceptable alternatives shall be permitted with engineer's prior approval only. Contractor to submit a detailed summary form listing all variations to include size deviations, electrical load differences, functional and component changes, and savings to end user.

1.6 Quality Assurance

The specified system shall be factory-tested before shipment. Testing shall include but shall not be limited to: Quality Control Checks, "Hi-Pot." The system shall be designed and manufactured according to world-class quality standards.

2.0 PRODUCT

2.1 Cabinet Section

2.1.1 Frame

The unit frame section shall be constructed of 10-gauge and 12-gauge riveted structure.

2.1.2 Panels

Panels shall be painted steel with matte black finish. A hinged control access panel shall open to a second front panel, which is a protective enclosure for all high voltage components.

2.1.3 Horizontal Air Discharge

The supply air shall exit from the front (data hall side) of the unit.

2.1.4 Discharge Grills

Discharge grills shall have a mesh pattern 2" (51 mm) x 7.5" (191 mm).

2.1.5 Filters

The filter chamber shall be located on the gallery side of the chilled water coil cabinet. Filters shall be removable from the gallery side of the unit.

- **Filter Type, 4 in. MERV8 or MERV11**

Filters shall be deep pleated, 4" (102 mm) filters with an ASHRAE 52.2-2007 MERV8 or MERV11 rating.

Unit Model	Module	Filter Count	Filter Size (Inch)
CA60	Bottom	15	20 x 24 x 4
	Top	18	
CA80	Bottom	18	20 x 24 x 4
	Top	21	
	Bottom	3	16 x 24 x 4
	Top	3	

- **Extra Filter Set**

____ extra set(s) of filters shall be provided per system.

- **Filter Clog**

The filter clog shall sound an alarm when unit filters need to be changed (included with filter option).

2.2 Air Side/Fan Section

2.2.1 High Airflow, High Efficiency Fan

High airflow, high efficiency fans shall be Electronically Commutated DC motors, commonly referred to as EC fan. The fan speed shall be variable and automatically regulated via Modbus by the Liebert® iCOM™ control through all modes of operation. The fans shall be located to blow air over the slab coil to ensure even air distribution and maximum coil performance. Fan motors shall be nominal 4.96 hp (3.70 kW) each, with a maximum operating speed of 1420 rpm. Also available the option with integrated THDi filter.

Unit Model	Module	Fan Count
CA60	Bottom	3
	Top	3
CA80	Bottom	4
	Top	4

2.2.2 Ultra Performance Fan

Ultra Performance fans shall be Electronically Commutated DC motors, commonly referred to as an EC fan. The fan speed shall be variable and automatically regulated via Modbus by the Liebert® iCOM™ control through all modes of operation. The fans shall be located to blow air over the slab coil to ensure even air distribution and maximum coil performance. Fan motors shall be nominal 6.17 hp (4.6 kW) each, with a maximum operating speed of 1670 rpm. Also available the option with integrated THDi filter 6.44 hp (4.8kW).

Unit Model	Module	Fan Count
CA80	Bottom	4
	Top	4

2.3 Water Side/System Piping

2.3.1 Unit Water Circuit (Coil, Piping, and Valves)

Chilled water system, which includes bottom and top modules with coils, valves, and piping, shall be designed for a maximum system water pressure of 270 PSIG (1861 kPa).

2.3.2 Chilled Water Coil

The chilled water coil shall be designed for horizontal airflow. It shall be constructed of copper tubes and aluminum fins. A stainless-steel condensate drain pan shall be provided. The thermal unit shall include one coil for the top module and one coil for the bottom module.

CA60 and CA80 unit model shall include the following standard coil options:

Unit Model	Coil Type	FPI	Circuits	Description
CA60	4-Row Coil	12	54	Provides base cooling capacity
	6-Row Coil	12	54	Provides additional cooling capacity
	8-Row Coil	12	54	Provides maximum cooling capacity
CA80	6-Row Smart Coil	12	70	Optimized for 14°F – 16°F fluid dT
	6-Row Next Generation Coil	15	54	Optimized for 18°F – 20°F fluid dT

2.3.3 Chilled Water Control Valves

The water circuit shall include 2-way valves located in the top module: one valve for the top coil and one valve for the bottom coil. The motorized ball valves shall be 0-10 Vdc modulating type that provide proportional control in response to room temperature and humidity as sensed by the microprocessor control. Valves shall be designed for up to 400 PSIG (2758 kPa) water pressure rating. Valve close-off pressure differential shall be 100 PSI (689 kPa). Valve actuator fail-safe available options shall be fail-in-place and fail-open.

Unit Model	Valves per Coil	Total Valves	Valve Size
CA60	1	2	2" 1/2
CA80	1	2	3"

2.3.4 Chilled Water Pressure Independent Control Valves (Optional)

The 2-way pressure independent control valves shall be Modbus modulating types that provide proportional control in response to room temperature and humidity as sensed by the microprocessor control. They ensure higher accuracy and increased performance. Valves shall be designed for up to 360 PSIG (2482 kPa) water pressure rating. Valve close-off pressure differential shall be 200 PSI (1379 kPa). Valve actuator fail-safe available options shall be fail-in-place and fail-open.

Unit Model	Valves per Coil	Total Valves	Valve Size
CA80	2	4	2"

2.3.5 Internal Piping Connections Between Modules

Internal Supply and Return Chilled Water Connections Between Modules

The Vertiv™ CoolLoop Thermal Wall Top and Bottom modules shall be shipped with a holding charge of nitrogen. The supply and return piping that connect the top and bottom modules shall be field brazed connections.

Internal Condensate Connections Between Modules

The Vertiv™ CoolLoop Thermal Wall Top and Bottom module condensate drain hoses shall be connected in the field with factory provided hose clamps.

Internal Condensate Pump Piping Drain Line Connection Between Modules

The Vertiv™ CoolLoop Thermal Wall Top and Bottom module piping for optional condensate pump copper drain lines shall be field brazed together.

2.3.6 Customer Piping Connections

Brazed Customer Supply and Return Chilled Water Piping Connections

The supply and return chilled water connections shall be 4-1/8 in. OD CU and field brazed.

Flanged Customer Supply and Return Chilled Water Piping Connections - Optional

The optional, factory installed, supply and return chilled water flanged connections shall be 150 lb. Class steel pipe rated at 270 psi minimum to improve ease of customer connection to field supplied flanges and piping.

Grooved Customer Supply and Return Chilled Water Piping Connections - Optional (Only for CA80)

The optional, factory-installed, supply and return chilled water grooved connections shall be rated at 270 psi minimum, to improve ease of customer connection to field piping.

Condensate Customer Drain Connection

The factory provided condensate drain connection shall be ¾" FPT. Field to provide condensate drain from the unit per local code.

Condensate Pump Drain Connection

The factory provided condensate pump drain connection at the top of the unit shall be ½" OD CU. Field to provide connection per local code.

2.4 Electrical Components

2.4.1 Short Circuit Current Rating (SCCR)

The electrical panel shall provide at least 65,000A SCCR. Short circuit current rating (SCCR) is the maximum short circuit current a component or assembly can safely withstand when protected by a specific overcurrent protective device(s) or for a specified time.

2.4.2 Supply Air Sensor

The supply air temperature sensor shall provide real-time, direct feedback to the cooling unit to provide a consistent supply air temperature by adjusting the chilled water valve accordingly to maintain setpoint. The supply air temperature sensor will provide real-time monitoring of discharge air temperature on all other units.

CA60 unit model shall include the following standard supply air measuring system:

- One supply air temperature sensor, located on the top right corner of the bottom coil.
- Available upon request possibility to install extra supply air sensors.

CA80 unit model shall include the following standard supply air measuring system:

- Two 2T air temperature sensors with two sensible measuring points each, for a total of four sensible measuring points, one 2T sensor shall be located on the bottom coil and one on the top coil, with the sensible points placed in the middle of the coil surface.
- available upon request possibility to install extra supply air sensors.

2.4.3 Return Air Temperature and Humidity Sensors

The return air temperature and humidity sensor shall be included as standard on the Vertiv™ CoolLoop Thermal Wall unit. Sensors are used for monitoring temperatures for safety and alarming purposes and may be used for optional unit control.

2.4.4 Water Inlet/Outlet Temperature Sensor – Optional (Only for CA80)

The water inlet/outlet temperature sensor shall provide real-time water temperature values.

2.4.5 Common Alarm Contact Signal

One normally open type programmable common alarm is provided to interface user-selected alarms with a remote alarm monitoring device.

2.4.6 Remote Shutdown Terminal

The remote shutdown terminal shall provide the customer with a location to remotely shut down the unit, complying with the National Fire Code.

2.4.7 Locking Disconnect Switch

Locking Disconnect and Quick-Start Enabled

The locking type disconnect shall be a fused disconnect switch that can be accessed by opening the accent panel. Access to the high voltage electric panel compartment can be obtained only with the switch in the Off position. Fused disconnects are provided with a defeater button that allows access to the electrical panel when power is on.

Each Vertiv™ CoolLoop Thermal Wall shall have the Chilled Water Quick-Start feature enabled. After a loss of power, normally the Vertiv™ Liebert® iCOM™ control application takes approximately 60 seconds to reboot to allow the unit to provide airflow and cooling. Once the feature is enabled, the end user may configure a specific airflow output percent and cooling capacity output percent as desired. The unit shall operate at these configured values within approximately 10 seconds after a power restoration all while the Liebert® iCOM™ controller is rebooting. After the Liebert® iCOM™ has fully booted, the unit will continue normal operation.

Locking Disconnect, Quick-Start Enabled, and Capacitive Buffer—Optional

The locking type disconnect shall be a fused disconnect switch that can be accessed by opening the accent panel. Access to the high voltage electric panel compartment can be obtained only with the switch in the Off position. Fused disconnects are provided with a defeater button that allows access to the electrical panel when power is on.

Each Vertiv™ CoolLoop Thermal Wall shall have the Chilled Water Quick-Start feature enabled. After a loss of power, normally the Liebert® iCOM™ control application takes approximately 60 seconds to reboot to allow the unit to provide airflow and cooling. Once the feature is enabled, the end user may configure a specific airflow output percent and cooling capacity output percent as desired. The unit shall operate at these configured values within approximately 10 seconds after a power restoration all while the Liebert® iCOM™ controller is rebooting. After iCOM has fully booted, the unit will continue normal operation.

The unit shall be equipped with a capacitive buffer to provide the iCOM with a minimum of three minutes of ride-through power. The capacitive buffer shall provide power to the Liebert® iCOM™ control with embedded Unity functionality for continuous connectivity to Building Management System/Building Automation Systems (where applicable). This functionality is not available with valve configured for spring return closed.

Dual Locking Disconnects with ATS Control and Quick-Start Enabled—Optional

The Vertiv™ CoolLoop Thermal Wall unit shall be provided with two manual locking disconnect switches. The locking type disconnects shall be fused disconnect switches that can be accessed by opening the accent panel. Access to the high voltage electric panel compartment can be obtained only with the switches in the Off position. Fused disconnects are provided with a defeater button that allows access to the electrical panel when power is on.

The unit shall include reversing starter with ATS (automatic transfer switch) control.

The ATS control will be capable of the following features:

- Determine if power is available in both primary and secondary sources.
- Allow for selection of which source is primary and which source is secondary.
- Ability to automatically switch from primary to secondary source, in the event of primary power loss.
- Ability to automatically switch secondary to primary source when primary power returns.
- Ability to remove unit from active power source if there is:

- Voltage Imbalance
- Phase Loss
- Over/Under Voltage
- Over/Under Frequency
- Capability for 3rd party interface monitoring and control

Vertiv™ Liebert® iCOM™ control will pull key information from the ATS control, allowing for easy interpretation of the current operation without needing to open the unit's front panel, potentially interrupting operation.

Each Vertiv™ CoolLoop Thermal Wall shall have the Chilled Water Quick Start feature enabled. After a loss of power, normally the iCOM control application takes approximately 60 seconds to reboot to allow the unit to provide airflow and cooling. Once the feature is enabled, the end user may configure a specific airflow output percent and cooling capacity output percent as desired. The unit shall operate at these configured values within approximately 10 seconds after a power restoration all while the iCOM controller is rebooting. After the iCOM has fully booted, the unit will continue normal operation.

Dual Locking Disconnect with ATS Control, Capacitive Buffer, and Quick-Start Enabled - Optional

The Vertiv™ CoolLoop Thermal Wall unit shall be provided with two manual locking disconnect switches. The locking type disconnects shall be fused disconnect switches that can be accessed by opening the accent panel. Access to the high voltage electric panel compartment can be obtained only with the switches in the Off position. Fused disconnects are provided with a defeater button that allows access to the electrical panel when power is on.

The unit shall include reversing starter with ATS (automatic transfer switch) control.

The ATS control will be capable of the following features:

- Determine if power is available in both primary and secondary sources.
- Allow for selection of which source is primary and which source is secondary.
- Ability to automatically switch from primary to secondary source, in the event of primary power loss.
- Ability to automatically switch secondary to primary source when primary power returns.
- Ability to remove unit from active power source if there is:
 - Voltage Imbalance
 - Phase Loss
 - Over/Under Voltage
 - Over/Under Frequency
- Capability for 3rd party interface monitoring and control

Vertiv™ Liebert® iCOM™ control will pull key information from the ATS control, allowing for easy interpretation of the current operation without needing to open the unit's front panel, potentially interrupting operation.

The unit shall be equipped with a capacitive buffer to provide the Liebert® iCOM™ with a minimum of three minutes of ride-through power. The capacitive buffer shall provide power to the Liebert® iCOM™ control with embedded Unity functionality for continuous connectivity to Building

Management System/Building Automation Systems (where applicable). This functionality is not available with valve configured for spring return closed.

Each Vertiv™ CoolLoop Thermal Wall shall have the Chilled Water Quick-Start feature enabled. After a loss of power, normally the iCOM control application takes approximately 60 seconds to reboot to allow the unit to provide airflow and cooling. Once the feature is enabled, the end user may configure a specific airflow output percent and cooling capacity output percent as desired. The unit shall operate at these configured values within approximately 10 seconds after a power restoration all while the iCOM controller is rebooting. After the iCOM has fully booted, the unit will continue normal operation.

3.0 CONTROLS

3.1 Vertiv™ Liebert® iCOM™ Microprocessor Control With 7 In. Color Touchscreen

The Liebert® iCOM™ shall be microprocessor based with a 7 in., high definition, capacitive, color touchscreen display and shall be mounted in an ergonomic, aesthetically pleasing housing. The display and housing shall be viewable while the front panel is open or closed. The controls shall be menu driven. The system shall display user menus for active alarms, event log, graphic data, unit view/status overview (including the monitoring of room conditions, operational status in percentage of each function, date and time), total run hours, various sensors, display setup, and service contacts. A password shall be required to make system changes. Service menus shall include setpoints, standby settings (lead/lag), timers/sleep mode, alarm setup, sensor calibration, maintenance/wellness settings, options setup, system/network setup, auxiliary boards, and diagnostics/service mode. The Liebert® iCOM™ control shall provide Ethernet/RS-485 ports dedicated for BMS connectivity (i.e. Base-Comms).

- **Password Protection**—The Liebert® iCOM™ shall contain two unique passwords to protect against unauthorized changes. An auto hide/show feature allows the user to see applicable information based on the login used.
- **Unit Backup and Restore**—The user shall be able to create safe copies of important control parameters. The Liebert® iCOM™ shall have the capacity for the user to automatically backup unit configuration settings to internal memory or USB storage drive. Configuration settings may be transferred to another unit for a more streamlined unit startup.
- **Parameter Download**—The Liebert® iCOM™ shall enable the user to download a report that lists parameter names, factory default settings and user-programmed settings in .csv format for remote reference.
- **Parameter Directory**—The Liebert® iCOM™ shall provide a directory that lists all parameters in the control. The list shall provide Line ID numbers, parameter labels, and current parameter values.
- **Parameter Search**—The Liebert® iCOM™ shall have search fields for efficient navigation and parameter lookup.
- **Context-Sensitive Help**—The Liebert® iCOM™ shall have an on-board help database. The database shall provide context sensitive help to assist with setup and navigation of the menus.
- **Display Setup**—The user shall have the ability to configure the Liebert® iCOM™ information based on the specific user's preference. Language, units of measure, screen contrast, home screen layout, backlight timer, and the hide/show of certain readouts shall be configurable through the display.
- **Additional Readouts**—The Liebert® iCOM™ shall permit the user to configure custom widgets on the main screen. Widget options shall include items such as fan speed, call for cooling, call for free cooling, maintenance status, call for hot water reheat, call for electric reheat, call for dehumidification, call for humidification, airflow, static pressure, fluid flow rate, and cooling capacity.
- **Status LEDs**—The Liebert® iCOM™ shall provide the user with the unit's operating status using an integrated LED. The LED shall indicate if the unit has an active alarm; if the unit has an active alarm that has been acknowledged; or if the unit is On, Off, or in standby status.

- **Event Log**—The Liebert® iCOM™ shall automatically store the last 400 unit only events (messages, warnings, and alarms).
- **Service Contact Information**—The Liebert® iCOM™ shall have the ability to store the local service or sales contact information.
- **Upgradeable**— Vertiv™ Liebert® iCOM™ firmware upgrades shall be performed through a USB connection.
- **Timers/Sleep Mode**—The menu shall allow various customer settings for turning on/off unit.
- **Menu Layout**—The menus shall be divided into two main menu screens: User and Service. The User screen shall contain the menus to access parameters required for basic unit control and setup. The Service screen shall be designed for service personal and provides access to advanced control setup features and diagnostic information.
- **Sensor Calibration**—The menus shall allow unit sensors to be calibrated with external sensors.
- **Maintenance/Wellness Settings** - The menus shall allow reporting of potential component problems before they occur.
- **Options Setup**—The menus shall provide operation settings for the installed components.
- **Auxiliary Boards**—The menus shall allow setup of optional expansion boards.
- **Various Sensors**—The menus shall allow setup and display of optional custom sensors. The control shall include four customer-accessible analog inputs for field-provided sensors. The analog inputs shall accept a 4 to 20mA signal. The user shall be able to change the input to 0 to 5VDC or 0 to 10VDC. The gains for each analog input shall be programmable from the front display. The analog inputs shall be able to be monitored from the front display.
- **Diagnostics/Service Mode**—The Liebert® iCOM™ shall be provided with self-diagnostics to aid in troubleshooting. The microcontroller board shall be diagnosed and reported as pass/not pass. Control inputs shall be indicated as On or Off at the front display. Control outputs shall be able to be turned On or Off from the front display without using jumpers or a service terminal. Each control output shall be indicated by an LED on a circuit board.
- **Base-Comms for BMS Connectivity**—The Liebert® iCOM™ controller shall provide one Ethernet Port and RS-485 Port dedicated for BMS Connectivity. Provides ground fault isolated RS-485 Modbus, BACnet IP and Modbus IP network connectivity to Building Management Systems for unit monitoring and management. Also, provides ground fault isolated 10/100 baseT Ethernet connectivity for unit monitoring and management. The supported management interfaces include SNMP for Network Management Systems, HTTP for web page viewing, SMTP for email, and SMS for mobile messaging. The Liebert® iCOM™ controller can support dual IP on a single network and one 485 protocol simultaneously.

3.2 Alarms

All unit alarms shall be annunciated through both audio and visual cues, clearly displayed on the screen, automatically recorded in the event log and communicated to the customer's Building Management System/Building Automation System. The iCOM shall activate an audible and visual alarm in the event of any of the following conditions:

- High Temperature

- Low Temperature
- High Humidity
- Low Humidity
- Fan Fault
- Change Filters
- Loss of Air Flow
- Loss of Power
- Custom Alarms

Custom alarm inputs shall be provided to indicate facility-specific events. Custom alarms can be identified with programmable labels. Frequently used alarm inputs shall include:

- Leak Under Floor
- Smoke Detected
- Standby Unit On

Each alarm (unit and custom) shall be separately enabled or disabled, selected to activate the common alarm and programmed for a delay of 0 to 255 seconds.

3.3 iCOM Control Methods And Options

The Vertiv™ Liebert® iCOM™ shall be factory set to allow precise monitoring and control of the condition of the air entering and leaving the unit. This control shall include predictive methods to control air flow and cooling capacity-based control sensors installed. Proportional and Tunable PID shall also be user-selectable options.

3.3.1 Controlling Sensor Options

The Liebert® iCOM™ shall be flexible in the sense that it shall allow controlling the capacity and fan from multiple different sensor selections. The sensor selections shall be:

- Cooling Capacity
 - Supply
 - Remote
 - Return
- Fan Speed
 - Supply
 - Remote
 - Return
 - Manual (for diagnostics or to receive a signal from the BMS through Liebert remote monitoring devices or analog input)
 - Static Pressure

3.3.2 Temperature Compensation

The Liebert® iCOM™ shall have the ability to adjust the capacity output based on supply and return temperature conditions to meet SLA guidelines while operating to highest efficiency.

3.4 Multi-Unit Coordination

Liebert® iCOM™ teamwork shall save energy by preventing multiple units in an area from operating in opposing modes. Teamwork allows the control to optimize a group of connected equipped with Liebert® iCOM™ using the U2U (Unit to Unit) network. There shall be three modes of teamwork operation:

- **Teamwork Mode 1 (Parallel):** Is best in small rooms with balanced heat loads. The controlling temperature and humidity sensor readings of all units in operation (fan On) are collected to be used for an average or worst-case sensor reading (user selectable). The master unit shall send the operating requirements to all operating units in the group. The control band (temperature, fan, and humidity) is derived and shared among the units in the group. Each unit will receive instructions on how to operate from the Master unit based on how far the system deviates from the setpoints. Evaporator fans and cooling capacity are ramped in parallel.
- **Teamwork Mode 2 (Independent):** The Vertiv™ Liebert® iCOM™ calculates the worst-case demand for heating, cooling humidification and dehumidification. Based on the greatest demand within the group, each unit operates independently, meaning that the unit may respond to the thermal load and humidity conditions based on the units controlling sensors. All sensor readings are shared.
- **Teamwork Mode 3: Optimized Aisle (Optimized Aisle):** May be applied in large and small rooms with varying heat loads. Optimized Aisle is the most efficient teamwork mode that allows the unit to match cooling capacity with heat load. In the Optimized Aisle mode, the fans operate in parallel. Fans can be controlled exclusively by remote temperature or using static pressure with a secondary remote temperature sensor(s) as an override to ensure that the inlet rack temperature is being met. Cooling (Compressors, Vertiv™ Liebert® Economizer or Vertiv™ Liebert® EconoPhase) is controlled by off unit supply air conditions. The Liebert® iCOM™ calculates the average or worst-case sensor reading (user selectable) for heating, cooling, humidification, and dehumidification. Based on the demand within the group, units will be allowed to operate within that mode until room conditions are satisfied. This is the best form of control for a room with an unbalanced load.

3.5 Standby/Lead-Lag

The Liebert® iCOM™ shall allow planned rotation to keep equal run time on units and provide automated emergency rotation of operating and standby units.

3.6 Standby Unit Cascading

The Liebert® iCOM™ cascade option shall allow the units to turn On and Off based on heat load when utilizing Teamwork Mode 3–Optimized Aisle mode with remote temperature sensors. In Teamwork Mode 3, Cascade mode will stage units On based on the temperature and humidity readings and their deviation from setpoint. Cascade mode coordinates the fan speed dynamically to save energy and to meet cooling demands. For instance, with a iCOM group of six units and only 50% of the heat load, the iCOM shall operate only four units at 80% fan speed and leave the other two units in standby. As the heat load increases, the iCOM shall automatically respond to the new load and bring on another unit, increasing the units in operation to five. As the heat load shifts up or down, the control shall meet the needs by cascading units On or putting them back into standby.

3.7 Virtual Master

As part of the robust architecture of the Liebert® iCOM™ control, it shall allow for a virtual master that coordinates operation. The Virtual Master function shall provide smooth control operation if the group's communication is compromised. When the lead unit which is in charge of component

staging in teamwork, unit staging, and standby rotation becomes disconnected from the network, the Liebert® iCOM™ automatically assigns a virtual master. The virtual master shall assume the same responsibilities as the master until communication is restored.

3.8 Virtual Back-Draft Damper

The Liebert® iCOM™ shall allow the use of a virtual backdraft damper, eliminating the need for a mechanical damper. This shall allow the fans of a stand-by unit to spin in reverse at a low speed (15% or less) to act as a damper.

3.9 Wired Supply Sensor

Each iCOM shall have one factory supplied and connected supply air sensor that may be used as a controlling sensor or reference. When multiple sensors are applied for control purposes, the user shall be able to control based on a maximum or average temperature reading.

3.10 System Auto Restart

The auto restart feature shall automatically restart the system after a power failure. Time delay shall be programmable. An optional capacitive buffer may be provided for continuous control operation through a power outage.

3.11 Sequential Load Activation

On initial startup or restart after power failure, each operational load shall be sequenced with a minimum of one second delay to minimize total inrush current.

3.12 CW Quick-Start

Each Vertiv™ CoolLoop Thermal Wall shall have the Chilled Water Quick-Start feature enabled. After a loss of power, normally the iCOM control application takes approximately 60 seconds to reboot to allow the unit to provide airflow and cooling if Quick-Start feature is not enabled. Once the feature is enabled, the end user may configure a specific airflow output percent and cooling capacity output percent, as desired. The unit shall operate at these configured values within approximately 10 seconds after a power restoration all while the iCOM controller is booting. After Vertiv™ Liebert® iCOM™ has fully booted, the unit will continue normal operation.

3.13 Adaptive PID - CW Auto-Tuning

Liebert® iCOM™ shall support the use of Liebert's auto-tuning feature called Adaptive PID. Adaptive PID may be used for fan speed control or cooling capacity control. With Adaptive PID selected, Liebert® iCOM™ shall automatically recognize oscillations across multiple subsystems relating to the PI tuning associated with either mode of control and correct those oscillations with zero human intervention. This feature allows for better overall system operation and responds well to increasing/decreasing system load.

3.14 Supply Sensor Aggregation

Each Liebert® iCOM™ controller shall support the Supply Sensor Aggregation feature. Supply Sensor Aggregation allows for the use of additional remote 2T temperature sensors that are used to calculate an aggregated supply air temperature value which may be used for cooling capacity control. Each Liebert® iCOM™ controller can support up to five additional remote 2T sensors for supply sensor aggregation. Sensors must be ordered separately and may be in addition to WIRED REMOTE 2T sensor application.

4.0 MISCELLANEOUS OPTIONS

4.1 IBC Seismic Bracing SDS 0.75 - Optional

The Vertiv™ CoolLoop Thermal Wall cabinet shall include factory installed bracing, and must comply with IBC 2021, CBC 2022, Ip 1.0 and Sds 0.75 requirements, based on third-party analytic certification. A certificate of compliance is available upon request. Unit must be installed per factory installation instructions to fully comply with certification.

4.2 IBC Seismic Bracing SDS 2.5 - Optional

The Vertiv™ CoolLoop Thermal Wall cabinet shall include factory installed bracing that must comply with IBC 2021, CBC 2022, Ip 1.0, and Sds 2.5 requirements, based on third-party analytic certification. A certificate of compliance is available upon request. Unit must be installed per the factory installation instructions to fully comply with certification.

4.3 Total Harmonic Distortion Mitigation (THD) – Optional

The requirement for total harmonic distortion (THD) mitigation is application dependent. It is recommended that start-up measurements be conducted to evaluate if current THD levels are within acceptable limits. This option may be necessary in applications where the computer room air conditioner units operate on backup power sources, such as a generator, and the blower current exceeds 33% of the generator load capacity. THD mitigation may be required if the EC blower load constitutes a significant percentage of the UPS capacity (in installations with a UPS) or if the blower load represents a substantial portion of the utility service power, especially in installations with a weak power supply.

4.4 Power Monitoring - Optional

The unit shall be equipped with factory-programmed/installed power meter to monitor power characteristics for either individual component or total unit. The power meter allows the user to monitor meter connection status, input under voltage, input RMS voltage leg-to-leg and leg-to-ground, input current for each phase, energy consumption in kilowatt hours and instantaneous power in watts. In multi-unit applications, a phase loss protection routine shall place a unit into standby mode in the event that phase loss is detected.

4.5 Static Pressure Fan Control - Optional

A pressure transducer shall be factory installed in the unit and wired to an analog input on the Vertiv™ Liebert® iCOM™ control. The pressure ports on the transducer will be factory supplied with two sections of 50 ft. (15.2 m) tubing to be used for low and high side tubing with snubber installed close to the transducer on the high side. Tubing will be coiled and tied to the unit.

NOTE: Air probe is not provided.

4.6 Backdraft Barrier Plate Kit - Optional

Backdraft Barrier Plate Kit shall be used to block airflow for unit or fan section not in operation. Kit includes three or four plates. Multiple quantities may be selected per desired application.

4.7 High Airflow, High Efficiency Fan Handover Spares Kit - Optional

High Airflow, High Efficiency Fan Handover Spares Kit shall include critical spare parts (High Airflow, High Efficiency Fans, fuses, Liebert® iCOM™ unit control board, and display) for 460V Vertiv™ CoolLoop Thermal Wall.

4.8 High Airflow, High Efficiency Fan with Integrated THD Handover Spares Kit - Optional

High Airflow, High Efficiency Fan with integrated THD Handover Spare Kit shall include critical spare parts (one High Airflow, High Efficiency Fan with integrated THD, fuses, Liebert® iCOM™ unit control board, and display) for 460V Vertiv™ CoolLoop Thermal Wall.

4.9 Ultra Performance Fan Handover Spares Kit – Optional

Ultra Performance Fan Handover Spare Kit shall include critical spare parts (one Ultra Performance Fan, fuses, Liebert® iCOM™ unit control board, and display) for 460V Vertiv™ CoolLoop Thermal Wall.

4.10 Ultra Performance Fan with integrated THD Handover Spares Kit – Optional

Ultra Performance Fan with integrated THD Handover Spare Kit shall include critical spare parts (one Ultra Performance Fan with integrated THD, fuses, Liebert® iCOM™ unit control board, and display) for 460V Vertiv™ CoolLoop Thermal Wall.

4.11 Gravity Condensate Connection Conversion Kit - Optional

Gravity Condensate Connection Conversion Kit shall include all parts necessary to alter the standard gravity drain of the Vertiv™ CoolLoop Thermal Wall to allow either right hand or left hand gravity condensate drain connection from the unit when viewed from the Gallery Side. Some components from the standard assembly must be used for the conversion connection.

4.12 High Temperature Sensor - Optional

This sensor shall be factory-installed in the unit and shall be factory set to 125°F (52°C). It shall immediately shut down the environmental control system when activated. The sensor shall be mounted with the sensing element in the return air. This sensor is not meant to replace any fire detection system that may be required by local or national codes.

4.13 Smoke Sensor - Optional

The smoke sensor samples the return air, shuts down the unit upon activation, and sends visual and audible alarms. Dry contacts are available for a remote customer alarm. The smoke sensor includes a "supervision" contact closure. This smoke sensor is not intended to function as or replace any room smoke detection system that may be required by local or national codes.

4.14 Condensate Pump, Dual Float - Optional

The condensate pump shall be complete with an integral dual-float switch, pump, motor assembly, and reservoir. The secondary float shall send a signal to the Liebert® iCOM™, which will display the condensate pump alarm and shut down the unit upon high water condition. An additional dedicated normally open contact signal shall also be provided. The condensate pump shall be factory installed in the Vertiv™ CoolLoop Thermal Wall bottom module.

4.15 Remote Humidifier Contact - Optional

A pair of normally open contacts shall be provided for connection to a remote humidifier that allow the unit's humidity controller to control a humidifier outside the unit. Power to operate the remote humidifier does not come from the unit.

4.16 Remote Temperature and Humidity Sensors - Optional

Remote temperature and humidity sensor shall be provided in a vented case for mounting in the room to be conditioned. Includes 30 ft. (9m), 60 ft. (18m), 90 ft. (27m), 120 ft. (36m), or 150 ft. (45m) of cable supplied for connecting sensors to unit. Units are supplied without internal return air temperature and humidity sensors when remote sensor is selected.

4.17 Low Voltage Terminal Package - Optional

Factory-installed and factory-wired terminals shall be provided.

- **Remote Shutdown Terminals** - Two additional pairs of terminals provide the customer with additional locations to remotely shut-down the unit by field-installed devices or controls.
- **Extra Common-Alarm Contacts** - Two additional pairs of terminals provide the customer with normally-open contacts for remote indication of unit alarms.
- **Main-Fan Enabled Contact** - On Main Fan Enable, one set of normally-open contacts will close for remote indication of fan operation.
- **Vertiv™ Liebert® Liqui-Tect™ Shutdown** - 1 pair of dry contacts for the Liebert® Liqui-Tect™ sensor signal will provide unit shut down. (Liqui-Tect sensor is not included.)

4.18 LT460 Liebert® Liqui-Tect™ Sensor (Factory Installed) - Optional

LT460 Liebert® Liqui-Tect™ zone water sensor cable shall be factory wired and secured in the bottom of the Vertiv™ CoolLoop Thermal Wall Bottom Module. The LT460 provides zone leak coverage within the bottom module by utilizing a leak detection cable. A cable termination sensor box is powered by 24 VAC from the Vertiv™ CoolLoop Thermal Wall unit with two Form-C dry contact common alarm relay outputs rated at 24 VAC, 3 Amp to remotely signal leak detected, loss of power and cable fault. The leak cable consists of a four-conductor cable, with two conductors being jacketed with CL2P rated covering. The two remaining conductors are covered with porous non-conductive polymers. The cable is UL-listed with a CL2P rating. The end of the cable is terminated in matching male and female connectors for easy connection of cables from end to end. Accuracy of the leak cable is linear and within 1% of the length of the cable.

4.19 Liebert® Liqui-Tect™ Sensors (Maximum Of 2 Per Unit) - Optional

Liqui-Tect sensor(s) model _____ shall be field installed and connected to Vertiv™ CoolLoop Thermal Wall unit. The water sensor is a hermetically sealed solid-state device with no moving parts. When the sensor detects the presence of moisture, the alarm system is activated.

____ (quantity) solid state water sensors shall be provided for installation.

4.20 Vertiv™ Liebert® vNSA Network Switch - Optional

The Liebert® vNSA network switch is designed for networking multiple iCOM unit-level controllers together. There shall be two different styles of the vNSA14 panel available:

- Liebert® vNSA14—enclosure with network switches only
- Liebert® vNSA14 iCOM™-H - enclosure with network switches and 9-in. iCOM color touchscreen display

Each offering shall be housed inside a steel enclosure secured with a key lock and contain two network switches, providing a total of 14 Ethernet ports available for iCOM controller unit-to-unit networking. The Liebert® vNSA requires field supplied, hard wiring, 16AWG, 100-240VAC universal (12V, 1.5A) single-phase input power supply for 120V or 230V operation with factory supplied power connector.

4.21 Remote 2T Sensor(s) - Optional

Remote 2T sensors may be used for remote monitoring and control applications such as supply sensor aggregation. A maximum of 10 sensors for WIRED 2T and a maximum of five for the supply sensor application per unit.

As part of the U2U network, these WIRED 2T sensors shall be shared and used to control the cooling units and provide greater flexibility, visibility, and control to respond to changes in the conditioned space. When the sensors are used for control, the user may set the control to be based off a maximum or average of the selected highest temperature reading.

4.22 Motorized Damper Kit and Controls – Optional (Only for CA80)

The motorized damper is delivered separately and needs to be attached to the unit during installation in the field. The motorized damper is installed on the data hall side. The damper consists of four sections (two on the bottom module and two on the top module), which are controlled simultaneously by an actuator for each section. The damper actuators are accessible only on data hall side.

5.0 EXECUTION

5.1 Installation Of Thermal Management Units

The customer or the customer's representative shall be responsible for the following.

5.1.1 General

Install Thermal Management units in accordance with the manufacturer's installation instructions. Install units plumb and level, firmly anchored in locations indicated and maintain the manufacturer's recommended clearances.

5.1.2 Electrical Wiring

Install and connect electrical devices furnished by the manufacturer but not specified to be factory mounted. Furnish copy of the manufacturer's electrical connection diagram submittal to electrical contractor.

5.2 Piping Connections

Install and connect devices furnished by manufacturer but not specified to be factory mounted. Furnish copy of the manufacturer's piping connection diagram submittal to piping contractor.

5.2.1 Supply, Return, and Drain Water Piping

Connect water supply, water return, and drains to air conditioning unit. Provide pitch and trap as manufacturer's instructions and local codes require.

5.3 Field Quality Control

Start cooling units in accordance with the manufacturer's start-up instructions. Test controls and demonstrate compliance with requirements. These specifications describe requirements for a computer room environmental control system. The system shall be designed to maintain temperature and humidity conditions in the rooms containing electronic equipment.

The manufacturer shall design and furnish all equipment to be fully compatible with heat dissipation requirements.

5.3.1 Warranty Start-up and Control Programming

Install the indoor unit in accordance with manufacturer's installation instructions provided with seismic option. Firmly anchor maintaining manufacturer's recommended clearances. Mounting requirement details such as anchor brand, type, embedment depth, edge spacing, anchor-to-anchor spacing, concrete strength, special inspection and attachment to non-building structures must be outlined and approved by the Engineer of Record for the projection or building. Electrical, pipe, and duct connections must permit movement in three dimensions and isolate the unit from field connections. Electrical conduit shall be flexible, having at least one bend between the rigid connection at the unit cabinet and the connection to rigid conduit or foundation. The piping flexible connection or loop must be suitable for the operation pressure and temperature of the system. Furnish copy of manufacturer's piping connection diagram submittal to piping contractor.

Engage manufacturer's field service technician to provide warranty start-up supervision and assist in programming of unit(s) controls and ancillary panels supplied by them.

This page intentionally left blank

Connect with Vertiv on Social Media



<https://www.facebook.com/vertiv/>



<https://www.instagram.com/vertiv/>



<https://www.linkedin.com/company/vertiv/>



<https://www.x.com/Vertiv/>



Vertiv.com | Vertiv Headquarters, 505 N Cleveland Ave, Westerville, OH 43082 USA

© 2026 Vertiv Group Corp. All rights reserved. Vertiv™ and the Vertiv logo are trademarks or registered trademarks of Vertiv Group Corp. All other names and logos referred to are trade names, trademarks or registered trademarks of their respective owners. While every precaution has been taken to ensure accuracy and completeness here, Vertiv Group Corp. assumes no responsibility, and disclaims all liability, for damages resulting from use of this information or for any errors or omissions.

SL-80374_REVB_04-26