



Liebert[®] DS

Installer/User Guide

35 to 105 kW (10 to 30 ton) Capacity, Upflow and Downflow, 60 Hz,
Air Cooled, Water/Glycol Cooled, Dual Cooled, and Liebert[®] Econ-o-
Coil GLYCOOL Cooled

The information contained in this document is subject to change without notice and may not be suitable for all applications. While every precaution has been taken to ensure the accuracy and completeness of this document, Vertiv assumes no responsibility and disclaims all liability for damages resulting from use of this information or for any errors or omissions.

Vertiv recommends installing a monitored fluid detection system that is wired to activate the automatic closure of field-installed coolant fluid supply and return shut off valves, where applicable, to reduce the amount of coolant fluid leakage and consequential equipment and building damage. Refer to local regulations and building codes relating to the application, installation, and operation of this product. The consulting engineer, installer, and/or end user is responsible for compliance with all applicable laws and regulations relating to the application, installation, and operation of this product.

The products covered by this instruction manual are manufactured and/or sold by Vertiv. This document is the property of Vertiv and contains confidential and proprietary information owned by Vertiv. Any copying, use, or disclosure of it without the written permission of Vertiv is strictly prohibited.

Names of companies and products are trademarks or registered trademarks of the respective companies. Any questions regarding usage of trademark names should be directed to the original manufacturer.

Technical Support Site

If you encounter any installation or operational issues with your product, check the pertinent section of this manual to see if the issue can be resolved by following outlined procedures.

Visit <https://www.vertiv.com/en-us/support/> for additional assistance.

TABLE OF CONTENTS

1 Important Safety Instructions	1
2 Nomenclature and Components	11
2.1 Vertiv™ Liebert® DS Model Number Nomenclature	11
2.2 Component Location	13
3 Pre-installation Preparation and Guidelines	15
3.1 Planning Dimensions	15
3.2 Air Distribution Considerations for Downflow Units	16
3.3 Air Distribution Considerations for Upflow Units	18
3.4 Connections and System Setup	19
3.5 Operating Conditions	20
3.5.1 Cooling, Humidification and Dehumidification	20
3.5.2 Heating	20
3.6 Shipping Dimensions and Unit Weights	20
4 Equipment Inspection and Handling	23
4.1 Packaging Material	24
4.2 Handling the Unit while Packaged	24
4.3 Unpacking the Unit	25
4.3.1 Removing the Unit from the Skid with a Forklift	25
4.3.2 Removing the Unit from the Skid Using Rigging	26
4.3.3 Moving the Unit to the Installation Location Using Piano Jacks	28
4.4 Remove Shipping Blocks from Units with Semi-Hermetic Compressors	29
4.5 Placing the Unit on a Floor Stand	30
5 Piping and Refrigerant Requirements	31
5.1 Drain and Humidifier Fluid Piping	33
5.1.1 Field-installed, Gravity Fed Drain Line Requirements	34
5.1.2 Condensate Pump Drain Line Requirements	36
5.1.3 Water Supply Line Requirements for the Optional Humidifier	36
5.2 Refrigerant Piping and Charging	37
5.2.1 Refrigerant Piping Guidelines for Air Cooled Systems	37
5.2.2 Refrigerant Line Sizes and Equivalent Lengths	39
5.2.3 Refrigerant Charge Requirements for Air Cooled Systems	39
5.2.4 Additional Oil Requirements for Scroll and Digital Scroll Compressors	41
5.2.5 Evacuation, Leak Testing, and Charging Air Cooled Systems without Vertiv™ Liebert® Lee-Temp Receivers	44
5.2.6 Evacuation, Leak Testing, and Charging Air Cooled Systems with Vertiv™ Liebert® Lee-Temp “Flooded Condenser” Head Pressure Control System	49
5.3 Refrigerant Charge for Water/Glycol Cooled Systems	52
5.4 Water/Glycol Loop Piping Guidelines	53
5.4.1 Leak Checking for Unit and Field Installed Piping	54

- 6 Electrical Connections 55**
- 7 EC Fans and Plenums 57**
 - 7.1 Downflow Units with EC Fans 57
 - 7.1.1 Lowering the EC Fans into the Floor Stand on Downflow Models 57
 - 7.2 Upflow Unit Plenums with EC Fans 60
 - 7.2.1 Assembly Inspection 61
 - 7.2.2 Assemble Plenum Rear and Side Panels 67
 - 7.2.3 Place Assembled Panels and EC Fans on Top of Unit 71
 - 7.2.4 Wire the EC Fans 75
 - 7.2.5 Install Front Panels on Plenum 77
- 8 Checklist for Completed Installation 87**
 - 8.1 Moving and Placing Equipment 87
 - 8.2 Electrical Installation Checks 87
 - 8.3 Piping Installation Checks 87
 - 8.4 Other Installation Checks 87
- 9 Initial Start-up Checks and Commissioning Procedure for Warranty Inspection 89**
- 10 Maintenance 91**
 - 10.1 Filters 92
 - 10.1.1 Filter Replacement for Downflow Units 92
 - 10.1.2 Filter Replacement for Upflow Units 93
 - 10.2 Blower Drive System—EC Fans 95
 - 10.2.1 Protective Features 96
 - 10.2.2 Fan Impellers and Bearings Maintenance 97
 - 10.2.3 Fan Assembly Troubleshooting 97
 - 10.2.4 Removing EC Fans from Downflow Units 101
 - 10.2.5 Removing EC Fans from Upflow Units 105
 - 10.3 Blower Drive System—Forward Curved Blowers 109
 - 10.3.1 Upflow Motor Access 109
 - 10.3.2 Belt Removal 110
 - 10.3.3 Belt Installation and Tensioning 110
 - 10.3.4 Blower Bearing Maintenance 111
 - 10.3.5 Blower Bearing Inspection 111
 - 10.3.6 Blower Bearing Replacement 112
 - 10.3.7 Blower Motor 112
 - 10.3.8 Blower Motor Lubrication 112
 - 10.3.9 Blower Wheel 112
 - 10.4 Infrared Humidifier Maintenance 113
 - 10.4.1 Cleaning Humidifier Pan and Float Switch 114
 - 10.4.2 Changing Humidifier Lamps 115
 - 10.5 Condensate Drain and Condensate Pump System Maintenance 116

10.5.1	Condensate Drain	116
10.5.2	Condensate Pump	116
10.6	Air Cooled Condenser and Drycooler Maintenance	117
10.7	Electric Reheat Maintenance	117
10.8	Thermostatic Expansion Valve (TXV) Maintenance	117
10.8.1	Determining Suction Superheat	117
10.8.2	Adjusting Superheat Setting with the TXV	117
10.9	Compressor Maintenance	118
10.9.1	Compressor Oil	118
10.9.2	Scroll and Digital Scroll Compressor Maintenance	119
10.9.3	Semi-Hermetic Compressor Maintenance	119
10.9.4	Replacement Compressors	119
10.9.5	Rotalock Valve on Scroll and Digital-Scroll Compressors	119
10.9.6	Unloading Solenoids on a Digital Scroll Compressor	120
10.9.7	Compressor Electrical Failure (Motor Burnout)	120
10.9.8	Replacing a Compressor with Electrical Failure (Motor Burnout)	121
10.9.9	Compressor Mechanical Failure	121
10.9.10	Replacing a Compressor with Mechanical Failure	122
10.10	Motorized Ball Valve (MBV) Maintenance (Digital Scroll Compressors)	122
10.10.1	MBV Control	122
10.10.2	MBV Control Method	123
10.10.3	MBV Adjustment	123
10.10.4	MBV Start-up	123
10.10.5	MBV Location	123
10.10.6	MBV Manual Control	123
10.11	Facility Fluid and Piping Maintenance for Water and Glycol Systems	123
10.12	Glycol Solution Maintenance	124
10.13	Vertiv™ Liebert® Paradenser—Water Cooled Condenser Maintenance	124
10.13.1	Cleaning the Liebert® Paradenser	124
10.13.2	Water Regulating Valves Maintenance for Semi-Hermetic and Standard Scroll Compressors	125
10.14	Vertiv™ Liebert® Drycooler Aquastat Settings	126
11	Preventive Maintenance Checklist	129
Appendices	135
Appendix A:	Technical Support and Contacts	135
Appendix B:	Disassembling the Vertiv™ Liebert® DS for Transport	137
Appendix C:	Submittal Drawings	147

This page intentionally left blank

1 Important Safety Instructions

SAVE THESE INSTRUCTIONS

This manual contains important safety instructions that should be followed during the installation and maintenance of the Vertiv™ Liebert® DS. Read this manual thoroughly before attempting to install or operate this unit.

Only qualified personnel should move, install or service this equipment.

Adhere to all warnings, cautions, notices and installation, operating and safety instructions on the unit and in this manual. Follow all installation, operation and maintenance instructions and all applicable national and local building, electrical and plumbing codes.



WARNING! Arc flash and electric shock hazard. Can cause serious injury or death. Building and equipment damage may also result. Disconnect all local and remote electric power supplies and wear appropriate, OSHA-approved personal protective equipment (PPE) per NFPA 70E before working within the electric control enclosure. Customer must provide earth ground to unit, per NEC, CEC and local codes, as applicable.

Verify with a voltmeter that power is Off. The Vertiv™ Liebert® iCOM™ controller does not isolate power from the unit, even in the “Unit Off” mode. Some internal components still require and receive power even during the “Unit Off” mode of the Liebert® iCOM™ controller. The factory-supplied, optional disconnect switch is inside the unit. The line side of this switch contains live high voltage. The only way to ensure that there is NO voltage inside the unit is to install and open a remote disconnect switch. Refer to unit electrical schematic.

Before proceeding with installation, read all instructions, verify that all the parts are included and check the nameplate to be sure the voltage matches available utility power. Follow all local codes.



WARNING! Risk of electric shock. Can cause serious injury or death. Building and equipment damage may also result. Open all local and remote electric power supply disconnect switches and verify that power is off with a voltmeter before working within any electric connection enclosures. The Liebert® iCOM™ controller does not isolate power from the unit, even in the "Unit Off" mode. Some internal components require and receive power even during the "unit off" mode of the Liebert® iCOM™ controller.

Installation, service, and maintenance work must be performed only by properly trained and qualified personnel and in accordance with applicable regulations and manufacturers' specifications. Opening or removing the covers to any equipment may expose personnel to lethal voltages within the unit even when it is apparently not operating and the input wiring is disconnected from the electrical source.



WARNING! Risk of electric shock. Can cause serious injury or death. Open all local and remote electric power supply disconnect switches and verify that power is off with a voltmeter before working within any electric connection enclosures. The Liebert® iCOM™ controller does not isolate power from the unit, even in the "Unit Off" mode. Fan-motor controls can maintain an electric charge for 10 minutes after power is disconnected. Wait 10 minutes after power is verified as off before working within the electric control/connection enclosures.

Installation, service, and maintenance work must be performed only by properly trained and qualified personnel and in accordance with applicable regulations and manufacturers' specifications. Opening or removing the covers to any equipment may expose personnel to lethal voltages within the unit even when it is apparently not operating and the input wiring is disconnected from the electrical source.



WARNING! Risk of electric shock. Can cause serious injury or death. Open all local and remote electric power supply disconnect switches and verify that power is off with a voltmeter before working within any electric connection enclosures. The Vertiv™ Liebert® iCOM™ controller does not isolate power from the unit, even in the "Unit Off" mode. Condensate pump will stay energized and has the potential to operate even in the "Unit Off" mode.

Installation, service, and maintenance work must be performed only by properly trained and qualified personnel and in accordance with applicable regulations and manufacturers' specifications. Opening or removing the covers to any equipment may expose personnel to lethal voltages within the unit even when it is apparently not operating and the input wiring is disconnected from the electrical source.



WARNING! Risk of short circuits and electric shock. Can cause serious injury or death. Building and equipment damage can result from cut insulation or damaged wires. Can cause overheated wiring, smoke, fire, activation of fire suppression systems and EMS personnel, and loss of power to fans. Verify that all wiring connections are tight and that all wiring is contained within the junction box prior to closing and securing the cover.

Insert CSA-certified or UL-listed bushings into holes and/or knockouts used to route wiring through metal panels to protect the wire insulation from contact with sheet metal edges.



WARNING! Risk of improper wire sizing/rating and loose electrical connections causing overheated wire and electrical connection terminals resulting in smoke or fire. Can cause serious injury or death. Building and equipment damage may also result. Use correctly sized copper wire only and verify that all electrical connections are tight before turning power On. Check all electrical connections periodically and tighten as necessary.



WARNING! Risk of over-pressurization of the refrigeration system. Can cause serious injury or death. Building and equipment damage may also result. Can cause explosive discharge of high-pressure refrigerant, loss of refrigerant, or environmental pollution. This unit contains fluids and gases under high pressure. Use extreme caution when charging the refrigerant system. Do not pressurize the system higher than the design pressure marked on the unit's nameplate.



WARNING! Risk of extremely heavy fan modules dropping downward suddenly. Can cause serious injury or death. Building and equipment damage may also result. Fan modules weigh in excess of 125-lb (56.7-kg) each. Support fan modules before removing mounting hardware. Use caution to keep all body parts out of the fan module pathway of movement during removal or repositioning. Only properly trained and qualified personnel should work on this equipment.

More than one person may be required to complete the assembly and installation. Installer(s) must be properly trained and qualified to lift, move and manipulate very heavy equipment from floor level to the top of the unit. Wear appropriate, OSHA-approved PPE when moving, lifting, installing, and removing the fan(s) and plenum. Read and follow the lifting equipment and/or ladder manufacturer's operating instructions and safety requirements.



WARNING! Risk of improper moving. Can cause serious injury or death. Building and equipment damage may also result. Use only lifting equipment that is rated for the unit weight by an OSHA-certified rating organization. The center of gravity varies depending on the unit size and selected options. The slings must be equally spaced on either side of the center of gravity indicator. Shipping weights and unit weights are listed in **Table 3.3** on page 20 and **Table 3.4** on page 21 . Use the center of gravity indicators on the unit to determine the position of the slings.



WARNING! Risk of contact with high-speed rotating fan blades. Can cause serious injury or death. Open all local and remote electric power-supply disconnect switches, verify with a voltmeter that power is off, and verify that all fan blades have stopped rotating before working in the unit cabinet or on the fan assembly. If control voltage is applied, the fan motor can restart without warning after a power failure. Do not operate the unit with any or all cabinet panels removed. Do not operate upflow units without installing a plenum, duct work or guard over the blower opening(s) on the top surface of the unit cabinet. Ductwork must be connected to the blower(s), or a plenum must be installed on the blower deck for protection from rotating blower wheel(s) on upflow units.



WARNING! Risk of top-heavy unit falling over when improperly lifted or moved. Can cause serious injury or death. Building and equipment damage may also result. Read all of the following instructions and verify that all lifting and moving equipment is rated for the weight of the unit before attempting to move, lift, remove packaging from or prepare the unit for installation. Unit weights are specified in **Table 3.3** on page 20 and **Table 3.4** on page 21 .



WARNING! Risk of contact with sharp edges, exposed fasteners, and improper handling of very heavy parts. Can cause serious injury or death. Building and equipment damage may also result. Use extreme caution, wear appropriate, OSHA-approved PPE, and install the EC fan(s) and plenum to the unit only as described in these instructions.

More than one person may be required to complete the assembly and installation. Installer(s) must be properly trained and qualified to lift, move and manipulate very heavy equipment from floor level to the top of the unit.

Wear appropriate, OSHA-approved PPE when moving, lifting and installing the fan(s) and plenum.

Equipment used in moving, lifting and installing the fan(s) and plenum must meet OSHA requirements and be rated for the weight of the fan(s) and the plenum. If ladders are used, verify that they are rated for the combined weight of the fan(s), plenum and installer(s) as loaded. EC Fan and plenum weights are specified in **Table 7.1** on page 61 and **Table 7.2** on page 62 .

Read and follow the lifting equipment and/or ladder manufacturer's operating instructions and safety requirements.



WARNING! Risk of improper drive-belt removal. Can cause serious injury or death. If improperly handled, the spring-loaded motor base can slam down suddenly causing serious injury to hands and fingers from crushing and pinching. Read the directions in this manual and on the unit instruction labels. Keep hands and fingers away from pinch points. Wear appropriate, OSHA-approved PPE when performing maintenance on the belts, motors or pulleys. Follow all directions when servicing the unit.



CAUTION: Risk of excessive refrigerant line pressure. Can cause equipment damage or injury resulting from tubing and component rupture. Do not close off the refrigerant-line isolation valve for repairs unless a pressure-relief valve is field- installed in the line between the isolation valve and the check valve. The pressure-relief valve must be rated 5% to 10% higher than the system-design pressure. An increase in ambient temperature can cause the pressure of the isolated refrigerant to rise and exceed the system-design pressure rating (marked on the unit nameplate).



CAUTION: Risk of improper moving, lifting and handling. Can cause injury. Building and equipment damage may also result. Only properly trained and qualified personnel should work on this equipment. Evaporator fan modules weigh in excess of 125-lb (56.7-kg). Use proper lifting techniques and wear appropriate OSHA-approved PPE to avoid injury and dropping the fan module during removal. Equipment used in handling/lifting, and/or installing the fan assembly must meet OSHA requirements. Use handling/lifting equipment rated for the weight of the fan assembly. Use ladders rated for the weight of the fan assembly and technicians if used during installation. Refer to handling/lifting, and/or installation equipment operating manual for manufacturer's safety requirements and operating procedures.



CAUTION: Risk of contact with sharp edges, splinters, and exposed fasteners. Can cause injury. Only properly trained and qualified personnel wearing appropriate, OSHA-approved PPE should attempt to move, lift, remove packaging from or prepare the unit for installation.



CAUTION: Risk of contact with hot surfaces. Can cause injury. Personal burn injury can be the result of touching a compressor, refrigerant discharge lines, and some electrical components that are extremely hot during unit operation. Allow sufficient time for them to cool to a touch-safe temperature before working within the unit cabinet.

Use extreme caution and wear appropriate, OSHA-approved PPE when working on or near hot components.



CAUTION: Risk of heavy unit falling into defective raised floor. Can cause injury and equipment damage. Prior to installation, all floor tiles immediately around floor stand are to be removed and inspected. Make sure tiles are not cracked, and ribs have not been cut. If free from defects, re-install. Replace with new tiles if defects are found.



CAUTION: Risk of contact with hot surfaces. Can cause injury. Personal burn injury can be the result of touching an electronics housing, fan motor, and some electrical components that are extremely hot during unit operation. Allow sufficient time for them to cool to a touch-safe temperature before working within the unit cabinet.

Use extreme caution and wear appropriate, OSHA-approved PPE when working on or near hot components, including when replacing or performing maintenance on the fans.



CAUTION: Risk of contact with hot surfaces. Can cause injury. Personal burn injury can be the result of touching a humidifier reservoir pan and/or water contained within the pan, and some electrical components that are extremely hot during unit operation. Allow sufficient time for them to cool to a touch-safe temperature before working within the unit cabinet.

Use extreme caution and wear appropriate, OSHA-approved PPE when working on or near hot components, including when replacing or performing maintenance on the infrared humidifier parts inclusive of its bulbs, metal enclosure, humidifier reservoir pan and/or water contained within the pan, and drain tubing. All infrared humidifier parts are very hot during and remain very hot shortly after operation.



CAUTION: Risk of improper handling heavy and lengthy parts. Can cause injury. Building and equipment damage may also result. Cabinet panels can exceed 5 ft. (1.5 m) in length and weigh more than 35 lb (15.9 kg). Follow relevant OSHA lifting recommendations and consider using a two-person lift for safe and comfortable removal and installation of cabinet panels. Only properly trained and qualified personnel wearing appropriate, OSHA-approved PPE should attempt to remove or install cabinet panels.



CAUTION: Risk of smoke generation. Can cause injury. Can cause fire suppression and alarm system activation, resulting in building evacuation and mobilization of emergency fire and rescue services. Start-up operation of optional electric reheat elements can create smoke or fumes that can activate the facility alarm and fire suppression system. Prepare and take appropriate steps to manage this possibility. Activating reheat during initial start-up may burn off particulates from electric reheat elements. Before beginning initial start-up checks, make certain that unit was installed according to the instructions in this manual. All exterior panels must be in place.



CAUTION: Risk of exposure to harmful noise levels. Can cause hearing injury or loss. Depending on the installation and operating conditions, a sound pressure level greater than 70 dB(A) may arise. Take appropriate technical safety measures. Operating personnel must wear appropriate, OSHA-approved PPE and observe all appropriate hearing-protection safety requirements.

NOTICE

Risk of improper power-supply connection. Can cause equipment damage and loss of warranty coverage.

Prior to connecting any equipment to a main or alternate power source (for example: back-up generator systems) for start-up, commissioning, testing, or normal operation, ensure that these sources are correctly adjusted to the nameplate voltage and frequency of all equipment to be connected. In general, power-source voltages should be stabilized and regulated to within $\pm 10\%$ of the load nameplate nominal voltage. Also, ensure that no three-phase sources are single-phased at any time.

NOTICE

Risk of oil contamination with water. Can cause equipment damage.

Vertiv™ Liebert® DS systems require the use of POE (polyolester) oil. POE oil absorbs water at a much faster rate when exposed to air than previously used oils. Because water is the enemy of a reliable refrigeration system, extreme care must be used when opening systems during installation or service. If water is absorbed into the POE oil, it will not be easily removed and will not be removed through the normal evacuation process. If the oil is too wet, it may require an oil change. POE oils also have a property that makes them act as a solvent in a refrigeration system. Maintaining system cleanliness is extremely important because the oil will tend to bring any foreign matter back to the compressor.

NOTICE

Risk of improper refrigerant charging. Can cause equipment damage.

Refrigerant charge must be weighed into air-cooled compressorized systems before they are started. Starting scroll and digital scroll compressors without proper refrigerant charging can cause the compressors to operate at less than 15°F (-9.4°C) evaporator temperature and at less than 32 psig (221 kPa). Operation for extended periods at less than 32 psig (221 kPa) can cause premature compressor failure.

NOTICE

Risk of clogged or leaking drain lines and leaking water-supply lines. Can cause equipment and building damage.

This unit requires a water drain connection. Drain lines must be inspected at start-up and periodically, and maintenance must be performed to ensure that drain water runs freely through the drain system and that lines are clear and free of obstructions and in good condition with no visible sign of damage or leaks. This unit may also require an external water supply to operate.

Improper installation, application and service practices can result in water leakage from the unit. Water leakage can result in catastrophic and expensive building and equipment damage and loss of critical data center equipment.

Do not locate unit directly above any equipment that could sustain water damage.

We recommend installing a monitored fluid-detection system to immediately discover and report coolant-fluid system and condensate drain-line leaks.

NOTICE

Risk of piping-system corrosion and freezing fluids. Can cause leaks resulting in equipment and expensive building damage. Cooling coils, heat exchangers and piping systems are at high risk of freezing and premature corrosion. Fluids in these systems must contain an inhibitor to prevent premature corrosion.

The system coolant fluid must be analyzed by a competent fluid-treatment specialist before start up to establish the inhibitor level and evaluated at regularly scheduled intervals throughout the life of the system to determine the pattern of inhibitor depletion. The fluid complexity and variations of required treatment programs make it extremely important to obtain the advice of a competent and experienced fluid-treatment specialist and follow a regularly scheduled coolant-fluid system-maintenance program.

Fluid chemistry varies greatly as do the required additives, called inhibitors, that reduce the corrosive effect of the fluids on the piping systems and components.

The chemistry of the coolant fluid used must be considered, because some sources may contain corrosive elements that reduce the effectiveness of the inhibited formulation. Sediment deposits prevent the formation of a protective oxide layer on the inside of the coolant system components and piping. The coolant fluid must be treated and circulating through the system continuously to prevent the buildup of deposits and/or growth of bacteria. Proper inhibitor maintenance must be performed to prevent corrosion of the system.

Consult fluid manufacturer for testing and maintenance of inhibitors.

Commercial-grade coolant fluid is generally less corrosive to the common metals of construction than water itself. It will, however, assume the corrosivity of the coolant fluid from which it is prepared and may become increasingly corrosive with use if not properly inhibited.

Vertiv recommends installing a monitored fluid-detection system that is wired to activate the automatic-closure of field-installed coolant-fluid supply and return shut-off valves to reduce the amount of coolant-fluid leakage and consequential equipment and building damage. The shut-off valves must be sized to close-off against the maximum coolant-fluid system pressure in case of a catastrophic fluid leak.

NOTICE

Risk of frozen pipes and corrosion from improper coolant mixture. Can cause water leaks resulting in equipment and building damage.

When the cooling unit or piping may be exposed to freezing temperatures, charge the system with the proper percentage of glycol and water for the coldest design ambient temperature. Automotive antifreeze is unacceptable and must NOT be used in any glycol fluid system. Use only HVAC glycol solution that meets the requirements of recommended industry practices. Do not use galvanized pipe.

NOTICE

Risk of a catastrophic water circuit rupture. Can cause expensive building and equipment damage.

Install an overflow drain pan under the unit with a monitored leak detection system in the pan and shutoff valves in the supply and return water lines that automatically close if water is detected by the leak detection system. The shutoff valves should be spring return and must be rated for a close-off pressure that is the same as or higher than the supply water pressure. If it is not possible to install an overflow drain pan, then a monitored leak detection system should be installed in the base of the unit or under the unit to actuate the shutoff valves immediately on a leak detection signal.

The overflow drain pan should have a drain line connected to it that flows to a floor drain or maintenance sink in case of a shutoff valve or leak detection system malfunction.

NOTICE

Risk of no-flow condition. Can cause equipment damage. Do not leave the water/coolant fluid-supply circuit in a no-flow condition. Idle fluid allows the collection of sediment that prevents the formation of a protective oxide layer on the inside of tubes. Keep unit switched On and water/coolant fluid-supply circuit system operating continuously.

NOTICE

Risk of improper water supply. Can reduce humidifier efficiency or obstruct humidifier plumbing.
Do not use a hot water source. It will cause deposits that will eventually block the fill-valve opening.

NOTICE

Risk of water backing up in the drain line. Leaking and overflowing water can cause equipment and building damage.
Do not install an external trap in the drain line. This line already has a factory-installed trap inside the cabinet. Installation of a second trap will prevent drain-water flow and will cause the water to overflow the drain pan.
Sagging condensate drain lines may inadvertently create an external trap.

NOTICE

Risk of passageway interference. Can cause unit and/or structure damage. The unit may be too large to fit through a passageway while on or off the skid. Measure the unit and passageway dimensions, and refer to the installation plans prior to moving the unit to verify clearances.

NOTICE

Risk of damage from forklift. Can cause unit damage. Keep tines of the forklift level and at a height suitable to fit below the skid and/or unit to prevent exterior and/or underside damage.

NOTICE

Risk of improper storage. Can cause unit damage.
Keep the unit upright, indoors and protected from dampness, freezing temperatures and contact damage.

NOTICE

Risk of improper control circuits. Can cause equipment damage.
When using jumpers for troubleshooting, always remove jumpers when maintenance is complete. Jumpers left connected could override controls and cause equipment damage.

NOTICE

Risk of improper filter installation. Can cause filter collapse and airflow reduction.

NOTICE

Condenser fans should be operated manually if they have not run for an extended time in an outdoor environment. Before enabling the condenser for normal cooling operation fans should be run at full speed for at least three hours once a month to move the bearings and allow any condensate that may have ingressed to evaporate. Condenser firmware release 1.06.042 & later include settings to operate condenser fans if they have been inactive for more than 30 days.

NOTE: The Vertiv™ Liebert® DS indoor cooling unit has a factory-installed, high-pressure safety switch in the high-side refrigerant circuit. Each refrigerant receiver contains a fusible plug for fire-safety purposes. Consult your local building code to determine whether the refrigerant piping will require additional, field-provided pressure-relief devices.

This page intentionally left blank

2 Nomenclature and Components

This section describes the model number for Vertiv™ Liebert® DS units and components.

2.1 Vertiv™ Liebert® DS Model Number Nomenclature

Table 2.2 below describes each digit of the model number.

Table 2.1 DS Model Number Example

1	2	3	4	5	6	7	8	9	10	11	12	13	14	15
D	S	0	3	5	A	D	A	1	E	I	*	*	*	*

Table 2.2 Liebert® DS Model Number Digit Definitions

Digit	Description
Digits 1 and 2 = Airflow Distribution	DS = Downflow standard VS = Upflow standard
Digit 3, 4, 5 = Nominal Cooling Capacity, kW	035 = 35 kW, 10 ton 042 = 42 kW, 12 ton 053 = 53 kW, 15 ton 070 = 70 kW, 20 ton 077 = 77 kW, 22 ton 105 = 105 kW, 30 ton
Digit 6 = Cooling Type	A = Air-cooled D = Dual-cool, air cooled H = Dual-cool, water cooled K = Vertiv™ Liebert® Econ-o-Coil GLYCOOL cooled W = Water/Glycol cooled
Digit 7 = Compressor Type	D = Digital scroll, R-407C S = Scroll, R-407C U = Semi-hermetic with 4-step, R-407C V = Semi-hermetic with 4-step, R-407C (DS105 water/glycol/GLYCOOL-only)

Table 2.2 Liebert® DS Model Number Digit Definitions (continued)

Digit	Description
Digit 8 = Voltage	<p>A = 460 V - 3 ph - 60 Hz</p> <p>B = 575 V - 3 ph - 60 Hz</p> <p>C = 208 V - 3 ph - 60 Hz</p> <p>D = 230 V - 3 ph - 60 Hz</p> <p>2 = 380 V - 3 ph - 60 Hz</p>
Digit 9 = Fan Type	<p>0 = Forward-curved blowers</p> <p>1 = Electronically-commutated (EC) fans</p>
Digit 10 = Reheat Type	<p>0 = None</p> <p>E = 3-stage electric</p> <p>R = Reduced, 3-stage electric</p>
Digit 11 = Humidifier	<p>0 = No humidifier</p> <p>I = Infrared Humidifier</p>
Digit 12-15 = Factory Configuration Number	

Not all combinations of options are available on all units:

- Digital Scroll Compressors
 - Not available on VS042A with forward-curved blower
 - Not available on 077 and 105 models
 - 575-V available only on 035, 053 and 070 models
- Scroll Compressors
 - Available on air cooled models 035 – 105
 - Available on water/glycol models 035 – 070
 - Scroll compressors not available on 77- and 105-kW models for water/glycol/Vertiv™ Liebert® GLYCOOL/Dual Cool units
- Liebert® GLYCOOL Econ-o-Coil Models
 - Available with digital-scroll compressors on 035 to 070 models, and with semi-hermetic compressors on 077 to 105 models
- High Pressure Water Regulating Valve
 - Not available on 042, 053, 070 and 077 models with semi-hermetic and scroll compressors

2.2 Component Location

The unit component locations are described in the submittal documents included in the [Submittal Drawings](#) on page 147 .

The following table lists the relevant documents by number and title.

Table 2.3 Component-location Drawings

Document Number	Title
DPN003706	Component Location, Downflow Models
DPN003707	Component Location, Upflow Models

This page intentionally left blank

3 Pre-installation Preparation and Guidelines

NOTE: Before installing unit, determine whether any building alterations are required to run piping, wiring and duct work. Follow all unit dimensional drawings and refer to the submittal engineering dimensional drawings of individual units for proper clearances.

Refer to [Liebert® DS Model Number Digit Definitions](#) on page 11, and submittal drawings to determine the type of system being installed and anticipate building alterations, piping and duct work needed.

The unit dimensions, pipe-connection locations, and piping schematics are described in the submittal documents included in the [Submittal Drawings](#) on page 147.

- Verify that the floor is level, solid and sufficient to support the unit. See **Table 3.3** on page 20 and **Table 3.4** on page 21 for unit weights.
- Confirm that the room is properly insulated and has a sealed vapor barrier.
- For proper humidity control, keep outside or fresh air to an absolute minimum (less than 5% of total air circulated in the room).
- Do not install a Vertiv™ Liebert® DS in an alcove or at the end of a long, narrow room.
- Install the units as close as possible to the largest heat load.
- Allow at least the minimum recommended clearances for maintenance and service. See the appropriate submittal drawings for dimensions.
- We recommend installing an under-floor water detection system. Contact your Vertiv representative for information.

3.1 Planning Dimensions

The unit, floor stand, and plenum dimensions are described in the submittal documents included in the [Submittal Drawings](#) on page 147.

The following table lists the relevant documents by number and title.

Table 3.1 Dimension Planning Drawings

Document Number	Title
Downflow Units	
DPN003643	Cabinet Dimensional Data, 35 to 105 kW (10 to 30 Tons) All Blower Types
Upflow Units	
DPN003681	Cabinet Dimensional Data Upflow 35-105kW (10-30 Tons) Models with EC Fans
DPN003646	Cabinet Dimensional Data Upflow 35 to 105 kW (10-30 Tons) with Forward Curved Blower
Floor Stands	
DPN003240	Floor Stand Dimensional Data 35kW - 42kW (10-12 Tons) with EC Fans
DPN003173	Floor Stand Dimensional Data 53kW - 77 kW (15-22 Tons) with EC Fans
DPN003174	Floor Stand Dimensional Data 105 kW (30 Tons) Models with EC Fans
DPN003134	Floor Stand and Floor Planning Dimensional Data Upflow 35-42 kW (10-12 Tons) Models with Forward Curved Blowers

Table 3.1 Dimension Planning Drawings (continued)

Document Number	Title
DPN003141	Floor Stand and Floor Planning Dimensional Data Upflow 53-77 kW (15-22 Tons) Models with Forward Curved Blowers
DPN003149	Floor Stand and Floor Planning Dimensional Data Upflow 105kW (30 Tons) Models with Forward Curved Blowers
Blower Outlet, Deck and Filter Box	
DPN001120	Blower Outlet and Deck Dimensional Data Upflow 35-42 kW (10-12 Tons) with Forward Curved Blowers
DPN001191	Blower Outlet and Deck Dimensional Data Upflow 53-77kW (15-22) Tons with Forward Curved Blowers
DPN001192	Blower Outlet and Deck Dimensional Data Upflow 105kW (30 Tons) with Forward Curved Blowers
DPN001196	Rear Return Filter Box Dimensional Data Upflow 35-105kW (10-30 Tons) All Compressor Models with Forward Curved Blowers
DPN003974	Rear Return Filter Box Dimensional Data Upflow 35-105kW (10-30 Tons) with EC Fans All Compressor Models
Plenums	
DPN003164	Upflow Plenum Dimensional Data 35kW-105kW (10-30 Tons) Models with Forward Curved Blowers
DPN003458	Plenum Dimensional Data Upflow 35-42kW (10-12 Tons) Models with EC Fans
DPN003453	Plenum Dimensional Data Upflow 53-77kW (15-22 Tons) with EC Fans
DPN003459	Plenum Dimensional Data Upflow 105kW (30 Tons) Models with EC Fans

3.2 Air Distribution Considerations for Downflow Units

- Verify that the raised floor has been properly sized for the unit's airflow and the room is free of airflow restrictions.
- Perforated floor tiles in the raised floor should ensure minimal pressure loss.
- The raised floor must provide 7-1/2 in. (191 mm) of clearance.
- A minimum of 24 in. (610 mm) is required to operate the fans when they are lowered with the factory-provided jacking mechanism.
- Ensure that there is adequate clearance above the unit for service, such as replacing filters.
- Optional plenums are available for downflow unit ducting.

Figure 3.1 Downflow Unit Ducting and Plenum Ducting

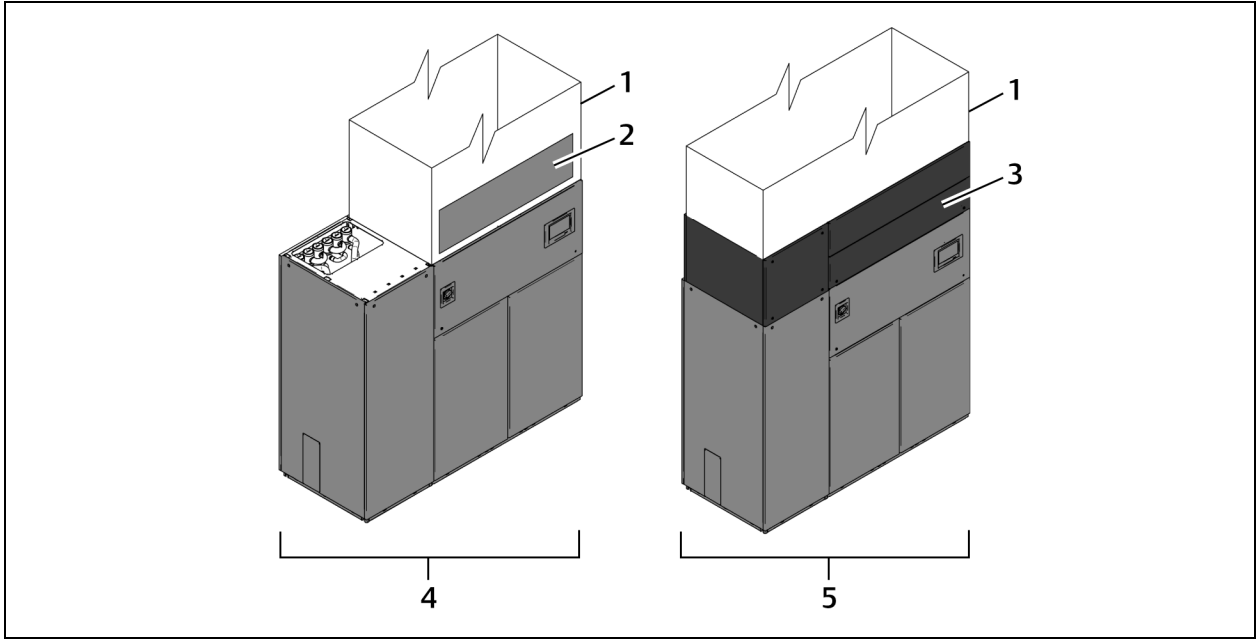

Item	Description
1	Field-fabricated duct work
2	Field service access for filter replacement Minimum height = 12 in. (305 mm) Minimum distance from unit = 2 in. (51 mm)
3	Optional plenum with service-access door for filter replacement
4	Direct-to-unit ducting
5	Plenum ducting

3.3 Air Distribution Considerations for Upflow Units

Various configurations are available:

- Front return
- Rear return
- Top-front supply (forward-curved blowers)
- Top-rear supply (forward-curved blowers)
- Top, rear, and front supply with plenum (EC fans)

For in-room applications with supply and return grilles, several feet of clearance must be maintained at the intake and discharge of the unit.

Upflow rear-return configurations use a filter box attached to the back of the unit. Allow 25 in. (635 mm) on one side of the unit for access to the rear-return filter box. Refer to the rear-return installation sheet, inside the rear-return filter box package.

Figure 3.2 Upflow Ducting Configurations (Forward Curved Blowers)

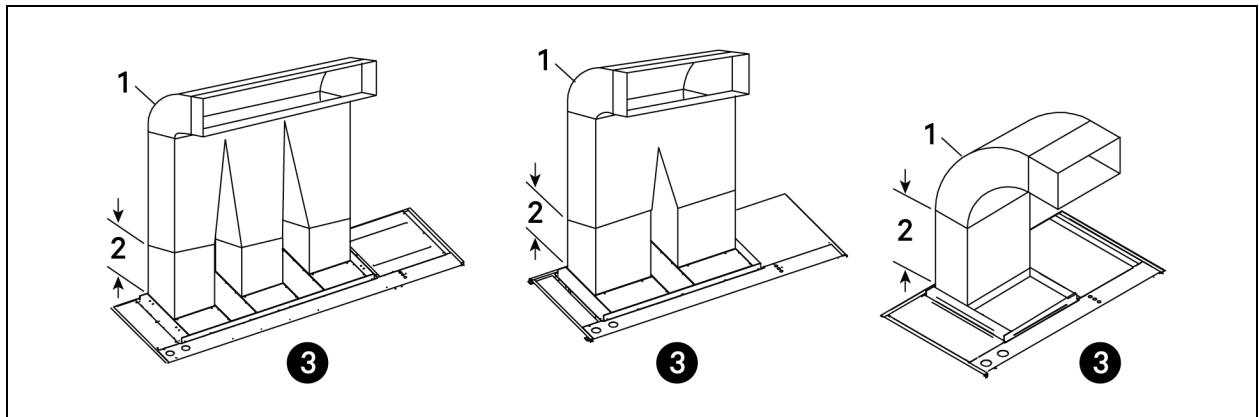

Item	Description
1	Typical ducting
2	Straight sections must be 1.5 to 2.5 times the longest blower dimension.
3	Front of unit

NOTE: Drain traps are qualified to a return duct static of negative 1.5 i.w.g. (-1.5 i.w.g).

Figure 3.3 Upflow Ducting Configurations for EC Fans

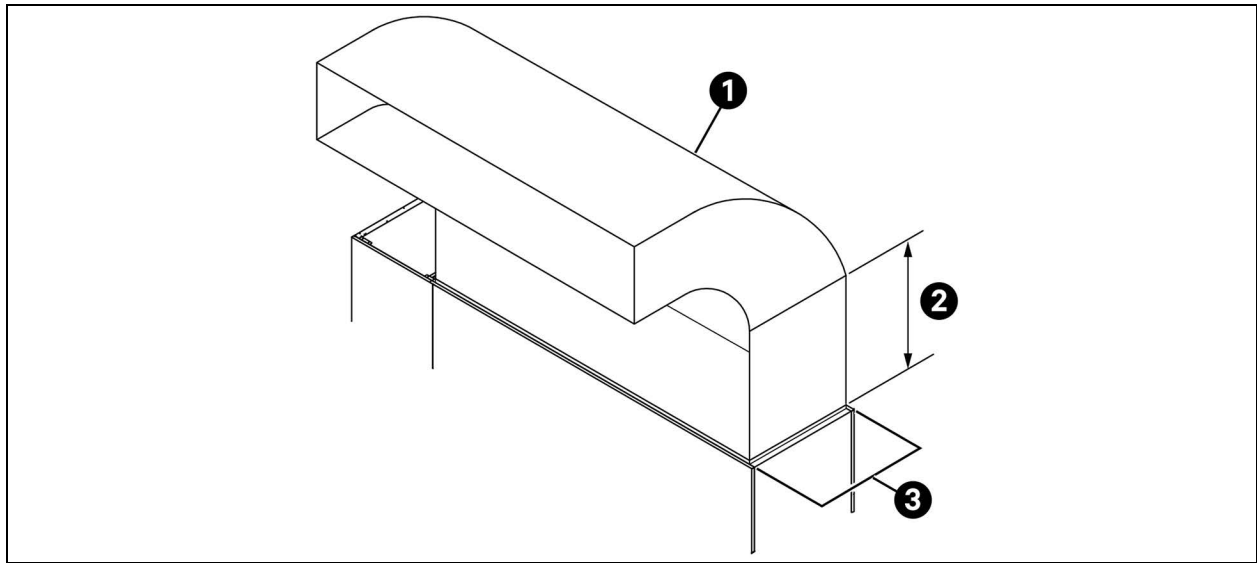

Item	Description
1	Typical ducting. May run to either side.
2	Straight section must be 2.5 times the depth of blower.
3	Ducting only attached to flanges on provided plenum.

NOTE: Follow standard practices in all duct work.

3.4 Connections and System Setup

- Three-phase electrical service is required for all models. Electrical service must conform to national and local electrical codes. See equipment nameplate for details.
- The unit requires a drain, which must comply with all applicable codes. See [Field-installed, Gravity Fed Drain Line Requirements](#) on page 34 , for details.
- Plan the routing of wiring, piping and duct work to the unit. Refer to the appropriate piping connection location drawings, piping schematics, and electrical-connection drawings for your system in [Submittal Drawings](#) on page 147 .
- Water/glycol and Vertiv™ Liebert® GLYCOOL units utilizing a drycooler may require an optional aquastat setting. See [Table 10.7](#) on page 126 , and [Table 10.8](#) on page 126 , through [Table 10.10](#) on page 127 , for drycooler aquastat setting guidelines. Applications with the optional stat setting require field piping to be insulated to prevent condensation.
- If seismic requirements apply, consult your Vertiv representative for information about a seismic-rated floor stand.

NOTE: Seal openings around piping and electrical connection to prevent air leakage. Failure to do so could reduce the unit's cooling performance.

3.5 Operating Conditions

The Vertiv™ Liebert® DS must be operated in a conditioned space within the operating envelope that ASHRAE recommends for data centers. Operating the Liebert® DS outside of this envelope can decrease equipment reliability. Refer to ASHRAE's publication, "Thermal Guidelines for Data Processing Environments."

3.5.1 Cooling, Humidification and Dehumidification

Return air to the unit must be no cooler than the ASHRAE recommendation of 68°F (20°C) DB and 40% RH or minimum WB of 54°F (12.2°C) for proper unit operation. Operating below this can decrease equipment reliability.

3.5.2 Heating

The Liebert® DS is qualified for heating-only operation at temperatures not exceeding 80°F (27°C).

3.6 Shipping Dimensions and Unit Weights

Table 3.2 Liebert® DS Shipping Dimensions—Domestic and Export

Cooling Type	Compressor Type	035/042	053/070/077	105
		LxWxH, in. (mm)	LxWxH, in. (mm)	LxWxH, in. (mm)
Air, Dual-Cool Air	Scroll or Digital-scroll	90x42x82 (2286x1067x2083)	102x42x82 (2591x1067x2083)	136x42x82 (3454x1067x2083)
Air, Dual-Cool Air	Semi-hermetic	—	114x42x82 (2896x1067x2083)	136x42x82 (3454x1067x2083)
Water/Glycol, GLYCOOL/Dual-Cool Water	Scroll or Digital-scroll	90x42x82 (2286x1067x2083)	114x42x82 (2896x1067x2083)	—
Water/Glycol, GLYCOOL/Dual-Cool Water	Semi-hermetic	—	114x42x82 (2896x1067x2083)	136x42x82 (3454x1067x2083)

Table 3.3 Liebert® DS Downflow Unit Weights and Shipping Weights—Approximate

Model Number	Compressor Type	Cooling Type	Downflow	Downflow Shipping Weights, lb (kg)	
			EC Fan Unit Weight, lb (kg)	Domestic, lb (kg)	Export, lb (kg)
DS035-042	Scroll or Digital-scroll	Air-cooled	1470 (668)	1608 (730)	1778 (807)
		Dual Cool Air	1620 (736)	1758 (798)	1928 (875)
		Water/Glycol	1780 (809)	1918 (870)	2088 (948)
		GLYCOOL/Dual Cool Water	1930 (877)	2068 (939)	2238 (1016)
DS053	Scroll or Digital-scroll	Air-cooled	1920 (871)	2070 (939)	2260 (1026)
		Dual Cool Air	2100 (953)	2250 (1021)	2440 (1107)
		Water/Glycol	2220 (1010)	2382 (1081)	2582 (1172)
		GLYCOOL/Dual Cool Water	2400 (1091)	2562 (1163)	2762 (1253)

Table 3.3 Liebert® DS Downflow Unit Weights and Shipping Weights—Approximate (continued)

			Downflow	Downflow Shipping Weights, lb (kg)	
Model Number	Compressor Type	Cooling Type	EC Fan Unit Weight, lb (kg)	Domestic, lb (kg)	Export, lb (kg)
DS070	Scroll or Digital-scroll	Air-cooled	1970 (894)	2120 (962)	2310 (1048)
		Dual Cool Air	2150 (975)	2300 (1044)	2490 (1130)
		Water/Glycol	2270 (1032)	2432 (1104)	2632 (1194)
		GLYCOOL/Dual Cool Water	2450 (1114)	2612 (1185)	2812 (1276)
DS077	Standard Scroll* (digital scroll not available)	Air-cooled	2020 (916)	2170(985)	2360 (1071)
	Semi-hermetic	Air-cooled	2450 (1114)	2612 (1185)	2812 (1276)
		Dual Cool Air	2630 (1196)	2792 (1267)	2992 (1358)
		Water/Glycol	2750 (1250)	2912 (1321)	3112 (1412)
		GLYCOOL/Dual Cool Water	2930 (1332)	3092 (1403)	3292 (1494)
DS105	Standard Scroll* (digital scroll not available)	Air-cooled	2660 (1207)	3103 (1408)	3323 (1508)
	Semi-hermetic	Air-cooled	2780 (1261)	3223 (1462)	3443 (1562)
		Dual Cool Air	3135 (1422)	3583 (1626)	3803 (1726)
		Water/Glycol	3150 (1429)	3593 (1630)	3813 (1730)
		GLYCOOL/Dual Cool Water	3505 (1590)	3953 (1794)	4173 (1893)

Table 3.4 Liebert® DS Upflow Unit Weights and Shipping Weights—Approximate

Model Number	Compressor Type	Cooling Type	Upflow		Upflow Shipping Weights, lb (kg) w/Forward-curved Blowers	
			EC Fan Unit Weight, lb (kg)	Forward-Curved Unit Weight, lb (kg)	Domestic, lb (kg)	Export, lb (kg)
VS035-042	Scroll or Digital-scroll	Air-cooled	1370 (621)	1520 (689)	1658 (753)	1828 (830)
		Dual Cool Air	1520 (689)	1670 (758)	1808 (821)	1978 (898)
		Water/Glycol	1680 (762)	1830 (830)	1968 (893)	2138 (970)
		GLYCOOL/Dual Cool Water	1830 (830)	1980 (898)	2118 (961)	2288 (1038)

Table 3.4 Liebert® DS Upflow Unit Weights and Shipping Weights—Approximate (continued)

Model Number	Compressor Type	Cooling Type	Upflow		Upflow Shipping Weights, lb (kg) w/Forward-curved Blowers	
			EC Fan Unit Weight, lb (kg)	Forward-Curved Unit Weight, lb (kg)	Domestic, lb (kg)	Export, lb (kg)
VS053	Scroll or Digital-scroll	Air-cooled	1900 (862)	2070 (939)	2220 (1007)	2410 (1094)
		Dual Cool Air	2080 (943)	2250 (1021)	2400 (1089)	2590 (1175)
		Water/Glycol	2200 (998)	2370 (1075)	2532 (1149)	2732 (1240)
		GLYCOOL/Dual Cool Water	2380 (1080)	2550 (1157)	2712 (1231)	2912 (1321)
VS070	Scroll or Digital-scroll	Air-cooled	1900 (862)	2070 (939)	2220 (1007)	2410(1094)
		Dual Cool Air	2080 (943)	2250 (1021)	2400 (1089)	2590 (1175)
		Water/Glycol	2200 (998)	2370 (1075)	2532 (1149)	2732 (1240)
		GLYCOOL/Dual Cool Water	2380 (1080)	2550 (1157)	2712 (1231)	2912 (1321)
VS077	Standard Scroll (Digital-scroll not available.)	Air-cooled	1900 (862)	2070 (939)	2220 (1007)	2410 (1094)
	Semi-hermetic	Air-cooled	2330 (1057)	2500 (1134)	2662 (1208)	2862 (1299)
		Dual Cool Air	2510 (1139)	2680 (1216)	2842 (1290)	3042 (1380)
		Water/Glycol	2630 (1193)	2800 (1270)	2962 (1344)	3162 (1435)
		GLYCOOL/Dual Cool Water	2810 (1275)	2980 (1352)	3142 (1426)	3342 (1516)
VS105	Standard Scroll (Digital-scroll not available.)	Air-cooled	2640 (1197)	2880 (1306)	3063 (1390)	3283 (1490)
	Semi-hermetic	Air-cooled	2760 (1252)	3000 (1361)	3183 (1444)	3403 (1544)
		Dual Cool Air	3090 (1402)	3330 (1510)	3513 (1594)	3733 (1694)
		Water/Glycol	3130 (1420)	3370 (1529)	3553 (1612)	3773 (1712)
		GLYCOOL/Dual Cool Water	3460 (1569)	3700 (1678)	3883 (1762)	4103 (1862)

4 Equipment Inspection and Handling



WARNING! Risk of improper wiring, piping, moving, lifting and handling. Can cause serious injury or death. Building and equipment damage may also result. Installation and service of this equipment should be done only by qualified personnel who have been specially-trained in the installation of air-conditioning equipment and who are wearing appropriate, OSHA-approved PPE.



WARNING! Risk of improper moving. Can cause serious injury or death. Building and equipment damage may also result. Use only lifting equipment that is rated for the unit weight by an OSHA-certified rating organization. The center of gravity varies depending on the unit size and selected options. The slings must be equally spaced on either side of the center of gravity indicator. Shipping weights and unit weights are listed in the tables in **Table 3.3** on page 20 . Use the center of gravity indicators on the unit to determine the position of the slings.



WARNING! Risk of top-heavy unit falling over when improperly lifted or moved. Can cause serious injury or death. Building and equipment damage may also result. Read all of the following instructions and verify that all lifting and moving equipment is rated for the weight of the unit before attempting to move, lift, remove packaging from or prepare the unit for installation. Unit weights are specified in **Table 3.3** on page 20 .

NOTICE

Risk of passageway interference. Can cause unit and/or structure damage. The unit may be too large to fit through a passageway while on or off the skid. Measure the unit and passageway dimensions, and refer to the installation plans prior to moving the unit to verify clearances.

NOTICE

Risk of damage from forklift. Can cause unit damage. Keep tines of the forklift level and at a height suitable to fit below the skid and/or unit to prevent exterior and/or underside damage.

NOTICE

Risk of improper storage. Keep the unit upright, indoors and protected from dampness, freezing temperatures and contact damage.

Upon arrival of the unit and before unpacking:

- Verify that the labeled equipment matches the bill of lading.
- Carefully inspect all items for visible or concealed damage.
- Report damage immediately to the carrier and file a damage claim with a copy sent to Vertiv or to your sales representative.

Equipment Recommended for Handling the Unit:

- Forklift
- Pallet jack
- Piano jacks
- Lift beam
- Slings
- Spreader bars

4.1 Packaging Material



All material used to package this unit is recyclable. Please save for future use or dispose of the material appropriately.

4.2 Handling the Unit while Packaged

If possible, transport the unit with a forklift or pallet jack. If that is not possible, use a crane with slings and spreader bars that are rated for the weight of the unit.

When using a forklift or pallet jack:

- Ensure that the fork length is suitable for the unit length and, if adjustable, spread to the widest allowable distance that will fit under the skid.
- When moving the packaged unit, lift the unit from the "HEAVY SIDE" of the unit, and do not lift the unit any higher than 6 in. (152 mm). All personnel except those moving the unit must be kept 12 ft (3.7 m) or more from the unit while it is being moved.
- If the unit must be lifted higher than 6 in. (152 mm), all personnel not directly involved in moving the unit must be 20 ft (5 m) or farther from the unit.
- Always refer to the location of the center-of-gravity indicators when lifting the unit, see **Figure 4.1** below .

Figure 4.1 Center of Gravity Indicator



4.3 Unpacking the Unit

1. Remove the exterior stretch wrap packaging and two V-shaped boards from around the unit, as shown in **Figure 4.2** below.
2. Remove the corner and side packaging planks, exposing the bag over the unit.

NOTE: The bag may remain in place to protect from dust and to protect the unit panels, or it may be removed for immediate installation.

3. Remove the bag from the unit when ready to remove the skid and install the unit.

Figure 4.2 Unpacking the Unit

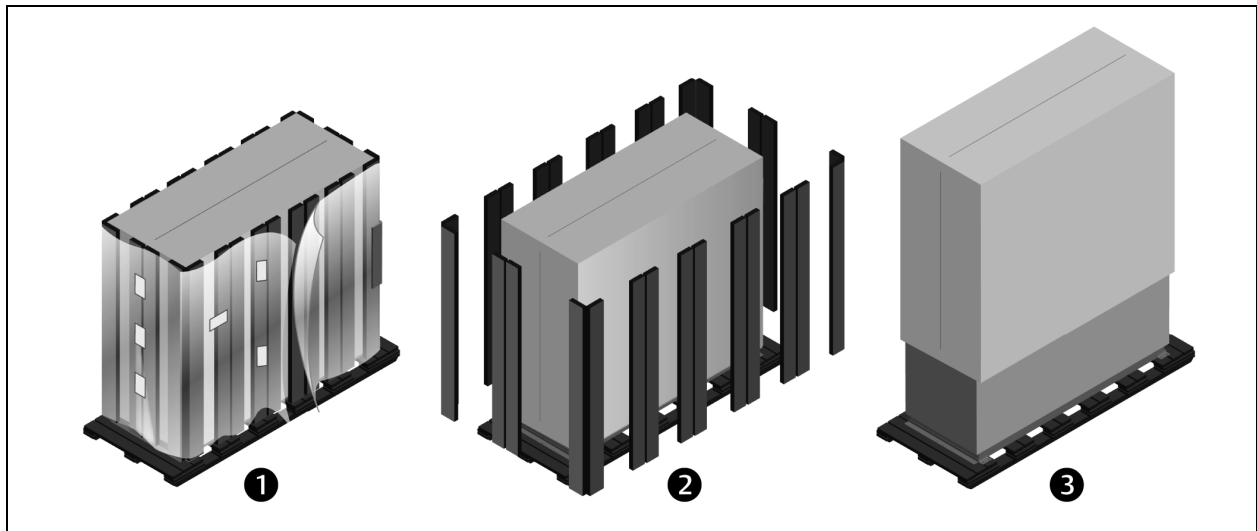

Item	Description
1	Remove exterior wrap from unit
2	Remove corner and side packaging planks
3	Leave the bag on the unit until ready to install.

4.3.1 Removing the Unit from the Skid with a Forklift

Refer to **Figure 4.3** on the next page.

1. Align a forklift with either the front or rear side of the unit.
 - Ensure that the tines of the fork lift are locked to the widest location.
 - Use the center of gravity indicators on the unit panels when determining the entry points for the tines. Center of gravity varies per unit size and selected options.
 - The tines shall be equally spaced on either side of the center of gravity indicator.

2. Insert the tines of the forklift completely under the base of the unit.
 - Ensure that the tines are level, not angled in an upward direction.
 - The tines are to be at a height that will allow proper clearance under the unit.
 - Ensure that the tines extend beyond the opposite side of the unit.

NOTE: If these steps are not followed, damage may occur to the panels and/or base of the unit.

3. Remove the lag bolts from each bracket located around the base, and remove the brackets.
4. Lift the unit off the skid to an elevation point where the skid is not supporting the weight of the unit and remove the skid from under the unit.

Figure 4.3 Removing From Skid with a Forklift

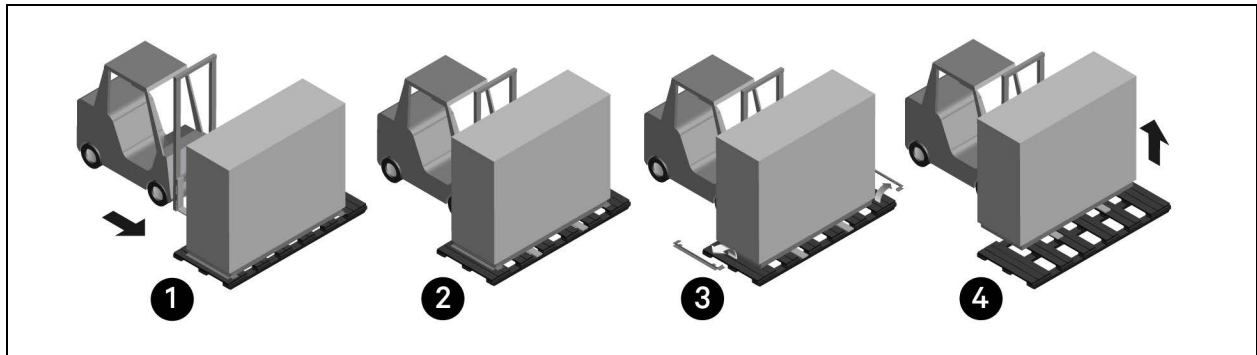

Item	Description
1	Align forklift with front or rear of unit.
2	Insert tines completely under base of unit.
3	Remove lag bolts and brackets
4	Lift unit and remove skid.

4.3.2 Removing the Unit from the Skid Using Rigging

1. Use the center-of-gravity indicators on the unit panels to determine the position of the slings.
 - The slings shall be equally-spaced on either side of the center-of-gravity indicator
2. Place the slings and between the bottom rails of the unit and the skid as shown in **Figure 4.4** on the facing page .

NOTE: Unit is shown without packaging. These instructions may be followed with or without the outer packaging in place.

Figure 4.4 Example Sling Placement

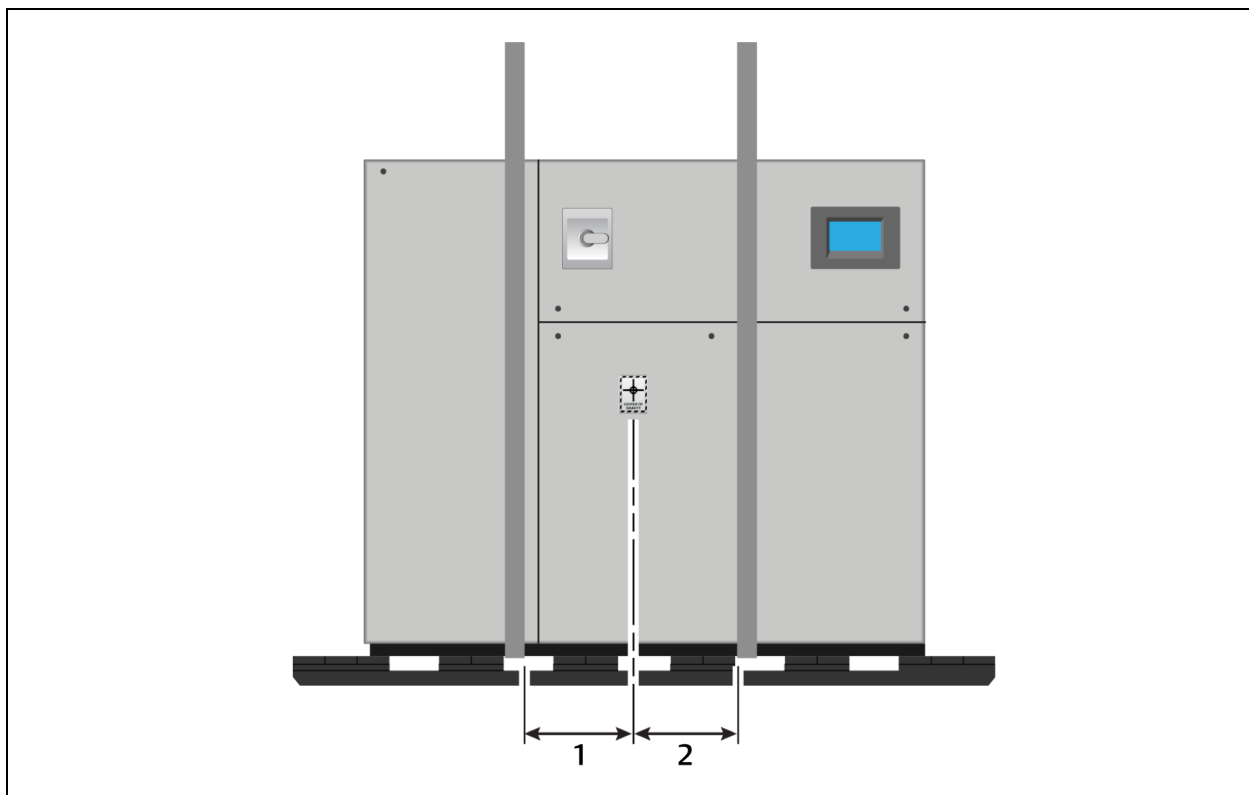

Item	Description
1	Distance between sling and center-of-gravity marker equal to item 2.
2	Distance between sling and center-of-gravity marker equal to item 1.

3. Referring to **Figure 4.5** below :
 - Align the slings as described previously.
 - Use spreader bars or equivalent device to ensure proper protection of the unit (Item 1).
 - Remove the lag bolts from each bracket located around the base, and remove the brackets (Item 2).

NOTE: Depending on final installation location, the skid may need to remain under the unit. Therefore, the lag bolts and brackets would not yet be removed.

- Lift the unit off the skid to an elevation point where the skid is not supporting the weight of the unit and remove the skid from under the unit (Item 3).

Figure 4.5 Moving Unit with Rigging

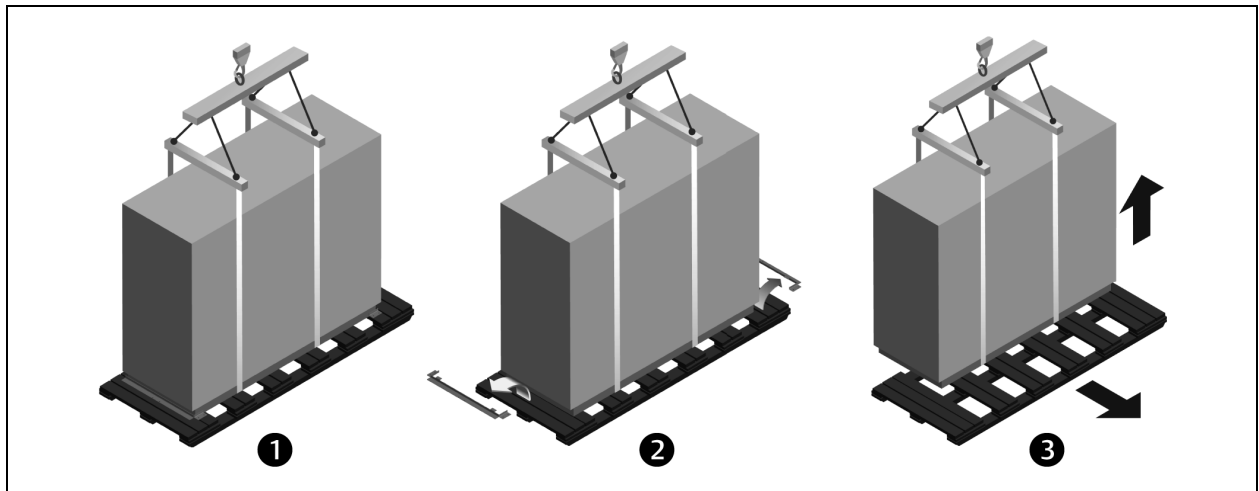

Item	Description
1	Spreader bars and rigging on unit.
2	Remove lag bolts and brackets.
3	Lift the unit and remove the skid.

4.3.3 Moving the Unit to the Installation Location Using Piano Jacks

Refer to **Figure 4.6** on the facing page .

1. With the unit elevated, position piano jacks at each end of the unit.
2. Lower the unit to a height suitable for the piano jacks, place protective material between the unit and the piano jacks and straps.

3. With the unit secured to the piano jacks, move the forklift away from the unit.
4. Using the piano jacks, at least two trained personnel can move the unit to the site for installation.
 - For location considerations, refer to [Pre-installation Preparation and Guidelines](#) on page 15.

Figure 4.6 Moving Unit with Piano Jacks

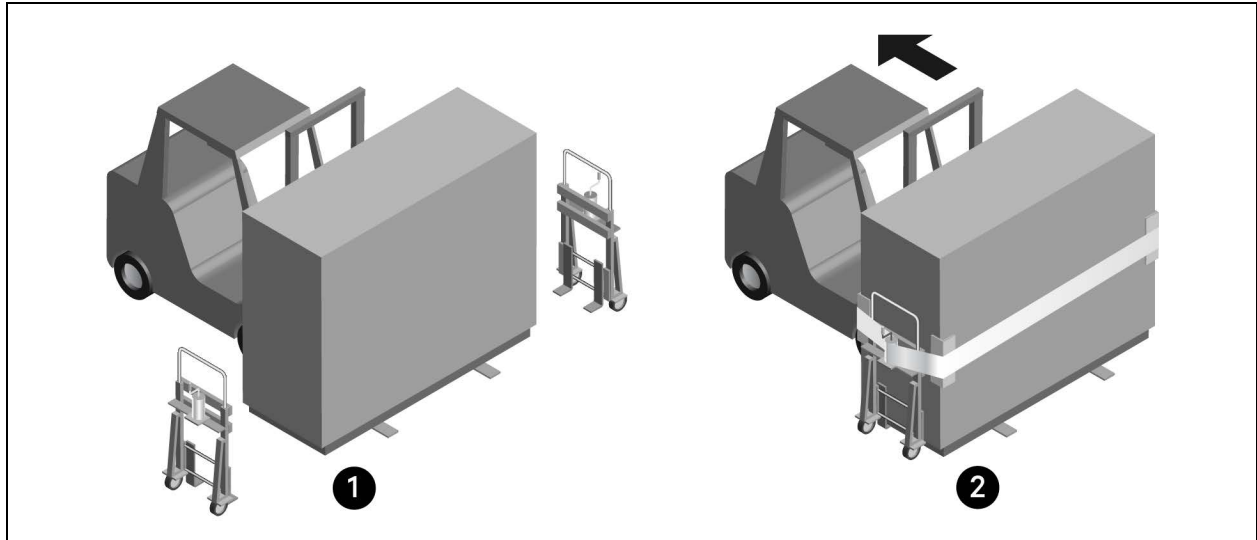

Item	Description
1	Place piano jacks on each end of the unit.
2	Use padding between unit and straps and, with the unit secured to the piano jacks, move the forklift away from the unit.

4.4 Remove Shipping Blocks from Units with Semi-Hermetic Compressors

The shipping blocks under all semi-hermetic compressors must be removed and the springs must be adjusted before start-up.

1. Loosen nuts at each of the four compressor feet and remove the two shipping blocks.
2. Beginning with one compressor foot, re-tighten nut until the washer under the nut can no longer be rotated by finger.
3. Loosen the nut half a turn. The washer will be slightly loose.
4. Repeat for remaining feet and recheck all when done.

4.5 Placing the Unit on a Floor Stand



CAUTION: Risk of heavy unit falling into defective raised floor. Can cause injury and equipment damage. Prior to installation, all floor tiles immediately around floor stand are to be removed and inspected. Make sure tiles are not cracked, and ribs have not been cut. If free from defects, re-install. Replace with new tiles if defects are found.

Refer to the floor-stand installation sheet, located inside the floor-stand package. Unit to be placed onto floor stand using process that will provide safest method based on site layout. Professional installers to be used when placing unit. Unit may require lift onto a floor stand if elevated flooring has not been installed. If flooring is installed, unit will be placed over floor opening containing floor stand. Refer to **Figure 4.7** below. Be sure to align the welded tabs on top of the floor stand with the inside of the unit frame base.

NOTE: The floor stand for the units equipped with EC fans is not symmetrical. Its orientation to the unit is critical for lowering the EC fans. Unless the floor stand is installed in the correct position, the fans will not lower into the floor stand.

Figure 4.7 Welded Tabs on Floor Stand

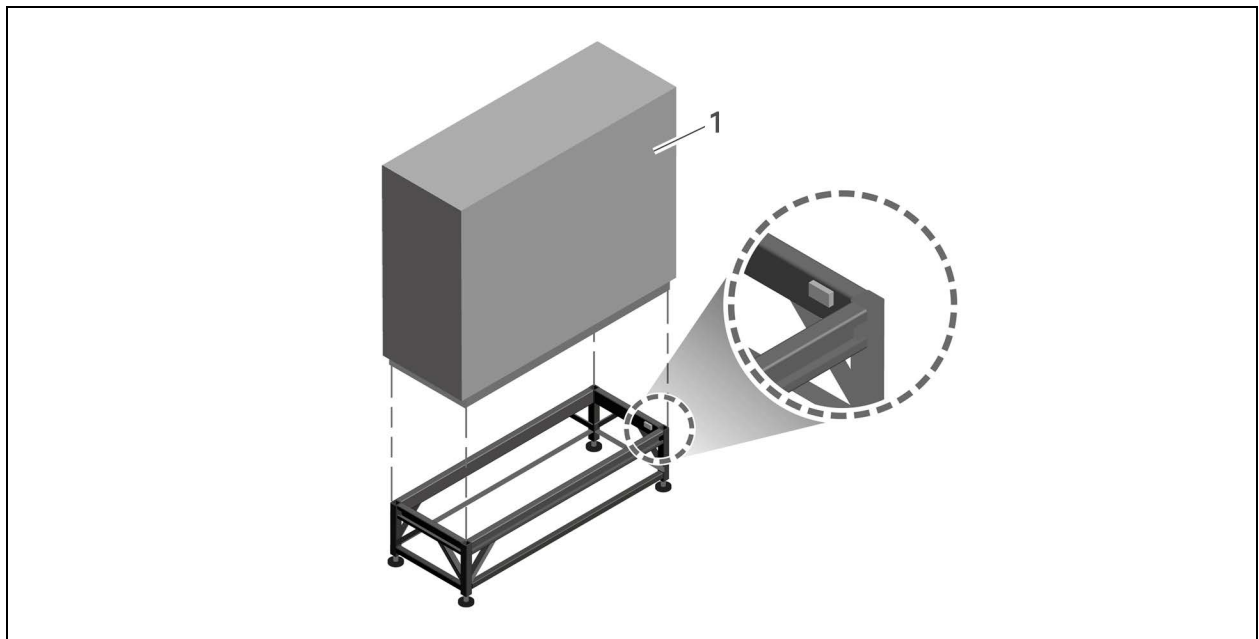

Item	Description
1	Front of unit

5 Piping and Refrigerant Requirements

All fluid and refrigeration connections to the unit, with the exception of the condensate drain, are sweat copper. Factory-installed piping brackets must not be removed. Field-installed piping must be installed in accordance with local codes and must be properly assembled, supported, isolated and insulated. Avoid piping runs through noise-sensitive areas, such as office walls and conference rooms.

Refer to specific text and detailed diagrams in this manual for other unit-specific piping requirements.

All piping below the elevated floor must be located so that it offers the least resistance to air flow. Careful planning of the piping layout under the raised floor is required to prevent the air flow from being blocked. When installing piping on the subfloor, we recommend that the pipes be mounted in a horizontal plane rather than stacked one above the other. Whenever possible, the pipes should be run parallel to the air flow.

The following pipe connections are required:

- A drain line from the unit.
- A water-supply line to the optional humidifier (if applicable).
- On air, water, or glycol systems: refrigerant piping connections between the evaporator unit and the condensing unit. See [Refrigerant Piping and Charging](#) on page 37 .
- On water-glycol systems: connections to a water or glycol loop.

The pipe connection locations, piping general arrangement and schematics are described in the submittal documents included in the [Submittal Drawings](#) on page 147 .

The following tables list the relevant documents by number and title.

Table 5.1 Piping General Arrangement Drawings

Document Number	Title
Air Cooled Units	
DPN003954	Air Cooled Piping Schematic Condenser Above Indoor Unit
DPN003730	Piping Schematic with Vertiv™ Liebert® MC Condenser Air Cooled Scroll or Digital Scroll Compressor
Water/Glycol Cooled Units	
NOTE: For systems with drycoolers, see Vertiv™ Liebert® Drycooler Aquastat Settings on page 126 .	
DPN000896	Piping Schematic Water/Glycol Scroll Compressor Models
DPN001430	Piping Schematic Water Glycol Digital Scroll Compressor Models
DPN000895	Piping Schematic Water/Glycol 77kW-105kW Semi-Hermetic Compressor Models
GLYCOOL Units	
NOTE: For systems with drycoolers, see Vertiv™ Liebert® Drycooler Aquastat Settings on page 126 .	
DPN000897	Piping Schematic GLYCOOL 77kW - 105kW Semi-Hermetic Compressor Models
DPN000898	Piping Schematic GLYCOOL Scroll Compressor Models
DPN001432	Piping Schematic GLYCOOL Digital Scroll Compressor Models
Vertiv™ Liebert® Econ-o-Coil Option	
DPN000805	Optional Piping Schematic Liebert® Econ-o-Coil Models

Table 5.2 Piping Connection Drawings

Document Number	Title
Downflow, Air Cooled Models with EC Fans	
DPN003239	Primary Connection Locations Downflow Air Cooled 35-42kW (10-12 Tons) Scroll or Digital Scroll Compressor Models
DPN002182	Primary Connection Locations Downflow Air Cooled 53-77kW Scroll or Digital Scroll Compressor Models with EC Fans
DPN002179	Primary Connections Downflow Air Cooled 77kW (22 Tons) Semi-Hermetic Compressor Models
DPN002154	Primary Connection Locations Downflow Air Cooled 105kW (30 Tons) All Compressor Models
Downflow, Water/Glycol/GLYCOOL Models with EC Fans	
DPN003530	Primary Connection Locations Downflow Water/Glycol/GLYCOOL 35-42kW (10-12 Tons) All Compressor Models
DPN002183	Primary Connection Locations Downflow Water/Glycol/GLYCOOL 53-77kW (15-22 Tons) All Compressor Models
DPN002153	Primary Connection Locations Downflow Water/Glycol/GLYCOOL (30 Tons) All Compressor Models
Upflow, Air Cooled Models with EC Fans	
DPN002740	Primary Connection Locations Upflow Air Cooled 35-42kW (10-12 Tons) Scroll or Digital Scroll Compressor Models with EC Fans
DPN002742	Primary Connection Locations Upflow Air Cooled 77kW (22 Tons) Semi-Hermetic Compressor Models with EC Fans
DPN002743	Primary Connection Locations Upflow Air Cooled 53-77kW (15-22 Tons) Scroll or Digital Scroll Compressor Models
DPN002745	Primary Connection Locations Upflow Air Cooled 105kW (30 Tons) All Compressor Models
Upflow, Water/Glycol/GLYCOOL Models with EC Fans	
DPN002741	Primary Connection Locations Upflow Water/Glycol/GLYCOOL 35-42kW (10-12 Tons) Scroll and Digital Scroll Compressor Models with EC Fans
DPN002744	Primary Connection Locations Upflow Water/Glycol/GLYCOOL 53-77kW (15-22 Tons) All Compressor Models with EC Fans
DPN002746	Primary Connection Locations Upflow Water/Glycol/GLYCOOL 105kW (30 Tons) All Compressor Models
Upflow, Air Cooled Models with Forward Curved Blowers	
DPN001119	Primary Connection Locations Upflow Air Cooled 35-42kW (10-12 Tons) Scroll or Digital Scroll Compressor Models with Forward Curved Blowers
DPN001212	Primary Connection Locations Upflow Air Cooled 77kW (22 Tons) Semi-Hermetic Compressor Models with Forward Curved Blowers
DPN001213	Primary Connection Locations Upflow Air Cooled 53-77kW 15-22 Tons Scroll or Digital Scroll Compressors
DPN001257	Primary Connection Locations Upflow Air Cooled 105kW (30 Tons) All Compressor Models

Table 5.2 Piping Connection Drawings (continued)

Document Number	Title
Upflow, Water/Glycol/GLYCOOL Models with Forward Curved Blowers	
DPN001179	Primary Connection Locations Upflow Water/Glycol/GLYCOOL 35-42 kW (10-12 Tons) Scroll and Digital Scroll Compressor Models with Forward Curved Blower
DPN001214	Primary Connection Locations Upflow Water/Glycol/GLYCOOL 53-77kW (15-22 Tons) All Compressor Models with Forward Curved Blowers
DPN001258	Primary Connection Locations Upflow Water/Glycol/GLYCOOL 105kW (30 Tons) All Compressor Models

5.1 Drain and Humidifier Fluid Piping

NOTICE

Risk of water leakage. Can cause severe property damage and loss of critical data center equipment.

The Vertiv™ Liebert® DS requires a water drain connection. Improper installation, application and service practices can result in water leakage from the unit.

Do not locate the unit directly above any equipment that could sustain water damage.

We recommend installing monitored leak detection equipment for the water supply lines and the internal unit water lines.

5.1.1 Field-installed, Gravity Fed Drain Line Requirements

NOTICE

Risk of water backing up in the drain line. Leaking and overflowing water can cause equipment and building damage.

Do not install an external trap in the drain line. This line already has a factory-installed trap inside the cabinet. Installation of a second trap will prevent drain-water flow and will cause the water to overflow the drain pan.

Sagging condensate drain lines may inadvertently create an external trap.

NOTICE

Risk of a catastrophic water circuit rupture. Can cause expensive building and equipment damage.

Install an overflow drain pan under the unit with a monitored leak detection system in the pan and shutoff valves in the supply and return water lines that automatically close if water is detected by the leak detection system. The shutoff valves should be spring return and must be rated for a close-off pressure that is the same as or higher than the supply water pressure. If it is not possible to install an overflow drain pan, then a monitored leak detection system should be installed in the base of the unit or under the unit to actuate the shutoff valves immediately on a leak detection signal.

The overflow drain pan should have a drain line connected to it that flows to a floor drain or maintenance sink in case of a shutoff valve or leak detection system malfunction.

A 3/4-in. NPT-Female drain connection is provided on units without an optional condensate pump.

Observe the following requirements and refer to **Figure 5.1** on the facing page, when installing and routing the drain line:

- The drain line must be sized for 2 gpm (7.6 l/m) flow.
- The drain line must be located so it will not be exposed to freezing temperatures.
- The drain should be the full size of the drain connection.
- The drain line must slope continuously away from the unit. Pitch drain line toward drain a minimum of 1/8 in. (3 mm) per 1 ft (305 mm) of length.
- Drain is trapped internally. Do not externally-trap the drain line.
- The drain line must be rigid enough that it does not sag between supports, which unintentionally creates traps.
- The drain line must comply with all applicable codes.
- On units with the optional, factory-installed condensate pump, see [Factory Installed Condensate Pump](#) on page 36 and [Condensate Pump Drain Line Requirements](#) on page 36.

Figure 5.1 Correct and Incorrect Gravity Drains for Downflow and Upflow Units

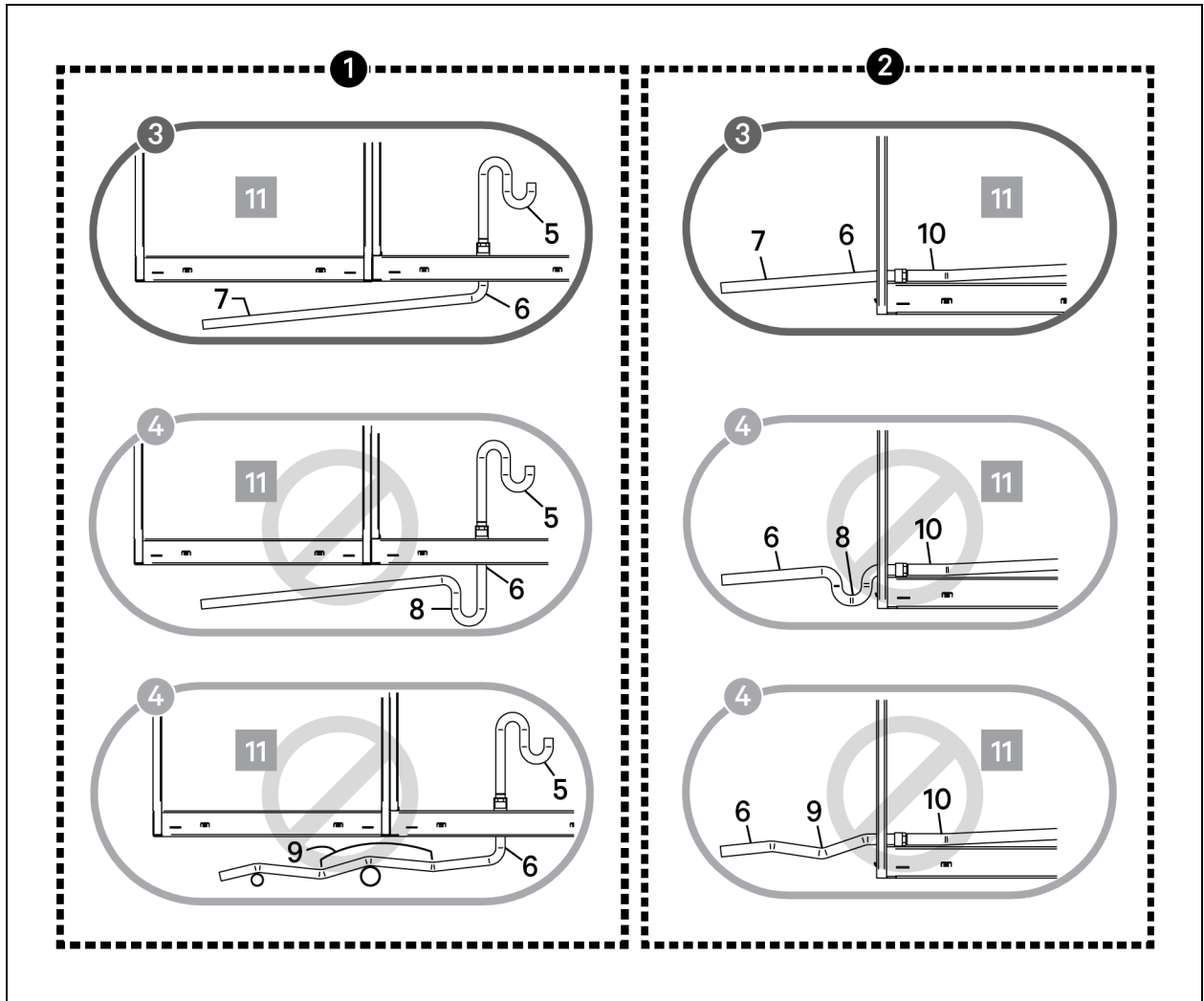

Table 5.3 Gravity Fed Drain Line Figure Descriptions

Item	Description
1	For downflow units
2	For upflow units
3	Correct drain installation
4	Incorrect drain installation
5	Internal drain
6	External drain
7	Continuous downward slope
8	External trap. Do not trap externally.

Table 5.3 Gravity Fed Drain Line Figure Descriptions (continued)

Item	Description
9	External traps, although unintentional. Lines must be rigid enough not to bow over top of other objects.
10	Internal drain
11	Liebert® DS unit

5.1.2 Condensate Pump Drain Line Requirements

NOTICE

Risk of water backing up in the drain line. Leaking and overflowing water can cause equipment and building damage.

Do not install an external trap in the drain line. This line already has a factory-installed trap inside the cabinet. Installation of a second trap will prevent drain-water flow and will cause the water to overflow the drain pan.

Sagging condensate drain lines may inadvertently create an external trap.

Observe the following requirements when installing and routing the drain line:

- The drain line must be located so it will not be exposed to freezing temperatures.
- Size the piping based on the available condensate head.
- Drain is trapped internally. Do not externally-trap the drain line.
- The drain line must be rigid enough that it does not sag between supports, which unintentionally creates traps.
- We recommend installing monitored, under-floor leak-detection equipment.

Factory Installed Condensate Pump

If your unit includes an optional condensate pump, the pump is factory-installed inside the unit and a 1/2-in. copper sweat connection is provided on the unit.

5.1.3 Water Supply Line Requirements for the Optional Humidifier

NOTICE

Risk of improper water supply. Can reduce humidifier efficiency or obstruct humidifier plumbing.

Do not use a hot water source. It will cause deposits that will eventually block the fill valve opening.

The unit may have an optional humidifier. Refer to the appropriate supply-line piping requirements if a humidifier is included on your unit:

Infrared Humidifier:

- 1/4-in. supply line, maximum water pressure is 150 psi (1034 kPa).
- Size supply line for 1 gpm (3.8 l/m), with a minimum water pressure of 20 psi (138 kPa).
- Do not supply de-ionized water to the humidifier.

5.2 Refrigerant Piping and Charging



WARNING! Risk of over-pressurization of the refrigeration system. Can cause explosive discharge of high-pressure refrigerant, loss of refrigerant, environmental pollution, equipment damage, injury, or death. This unit contains fluids and gases under high pressure. Use extreme caution when charging the refrigerant system. Do not pressurize the system higher than the design pressure marked on the unit's nameplate.

Consult local building and plumbing codes for installation requirements of additional pressure-relief devices when isolation valves are field installed. Do not isolate any refrigerant circuits from over-pressurization protection.

Table 5.4 System Refrigerant Pressures

Maximum Design Operating Pressure (High Side)	364 psig	(2510) kPa	Noted on the unit serial tag
High Pressure Cut Out Safety Switch	400 psig	(2758) kPa	Nominal
Source: DPN000788, Rev. 16			

NOTICE

Risk of oil contamination with water. Can cause equipment damage.

Vertiv™ Liebert® DS systems require the use of POE (polyolester) oil. POE oil absorbs water at a much faster rate when exposed to air than previously used oils. Because water is the enemy of a reliable refrigeration system, extreme care must be used when opening systems during installation or service. If water is absorbed into the POE oil, it will not be easily removed and will not be removed through the normal evacuation process. If the oil is too wet, it may require an oil change. POE oils also have a property that makes them act as a solvent in a refrigeration system. Maintaining system cleanliness is extremely important because the oil will tend to bring any foreign matter back to the compressor.

NOTICE

Units should never be operated with no refrigerant charge, a holding charge, a proper load or without additional oil as required added. Tag out system to prevent unauthorized personnel from accidentally starting equipment and damaging compressors if any of these conditions exist.

5.2.1 Refrigerant Piping Guidelines for Air Cooled Systems

- Field installed interconnecting piping should be properly selected based on local codes and unit labeling.
- Air cooled units ship with a nitrogen holding charge. Do not vent the charge until all refrigerant piping is in place, ready for connection to the unit and condenser.
- Use copper piping with a brazing alloy with a minimum temperature of 1350°F (732°C), such as Sil-Fos. Avoid soft solders, such as 50/50 or 95/5.
- Use a flow of dry nitrogen through the piping during brazing to prevent formation of copper oxide scale inside the piping. When copper is heated in the presence of air, copper oxide forms. POE oils will dissolve these oxides from inside the copper pipes and deposit them throughout the system, clogging filter driers and affecting other system components.
- A pure dry nitrogen flow of 1-3 ft³/min (0.5-1.5 l/s) inside the pipe during brazing is sufficient to displace the air. Control the flow using a suitable measuring device.

- Ensure that the tubing surfaces to be brazed are clean and that all burrs have been removed from the ends of the tubes.
- Ensure that all loose material has been cleaned from inside the tubing before brazing.
- Protect all refrigerant line components within 18 in. (460 mm) of the brazing site by wrapping them with a wet cloth or with a suitable heat-sink compound.
- Isolate piping from building using vibration-isolating supports.
- Condenser with receiver:
 - Cannot be installed below the evaporator.
 - The bottom of the receiver on the outdoor, MC condenser must be higher than the elevation of the thermal expansion valve (TXV) inside the indoor unit.
 - The vertical height of the bottom of the receiver must not exceed 60 ft. (18.3m) above the TXV.
 - Consult factory before installing units, condensers, and receivers outside these parameters.
 - Refer to DPN003954 and DPN003993 included in the [Submittal Drawings](#) on page 147 .
- Condenser without receiver:
 - The bottom of the condenser coil must be less than 15 feet below the location of the TXV inside the indoor unit.
 - The vertical height of the bottom of the condenser coil must not exceed 60 ft. (18.3m) above the TXV inside of the indoor unit.
 - Consult factory before installing units and condensers outside of these parameters.
 - Refer to DPN003954 included in the [Submittal Drawings](#) on page 147 .
- Consult factory if piping run exceeds 150 ft (46 m) equivalent length.
- Install traps on hot-gas (discharge) lines at the base of vertical risers over 5 ft (1.5 m) and then for vertical rises over 25 ft (7.6 m), install a trap in 20-ft (6-m) increments or evenly-divided over the vertical rise.
- Pitch horizontal hot-gas piping down at a minimum rate of 1/2 in. per 10 ft (42 mm per 10 m) so that gravity will aid in moving oil in the direction of refrigerant/oil flow.
- Keep piping clean and dry, especially on units with R-407C refrigerant.
- Avoid piping runs through noise-sensitive areas.
- Do not run piping directly in front of discharge air stream.
- Refrigerant oil. Do not mix oil types (see [Compressor Oil](#) on page 118).

Refer to ASHRAE Refrigeration Handbook for general, good-practice refrigeration piping.

- Refer to **Table 5.5** on the facing page , for recommended refrigerant piping sizes based on equivalent pipe lengths.
- Refer to [Refrigerant Charge Requirements for Air Cooled Systems](#) on the facing page , for the refrigerant-charge requirements of the system.
- Refer to [Charging Air Cooled Systems with Vertiv™ Liebert® Lee-Temp Receiver](#) on page 51 , for charging information.

5.2.2 Refrigerant Line Sizes and Equivalent Lengths

Table 5.5 Recommended Refrigerant Line sizes for Standard Scroll Models (Non-Digital Scroll) - OD Copper (Inches)

Model:	035		042		053		070		077		105	
Equivalent Length	Hot Gas Line	Liquid Line	Hot Gas Line	Liquid Line	Hot Gas Line	Liquid Line	Hot Gas Line	Liquid Line	Hot Gas Line	Liquid Line	Hot Gas Line	Liquid Line
50 ft (15 m)	7/8	1/2	7/8	1/2	7/8	5/8	1-1/8	7/8	1-1/8	7/8	1-3/8	7/8
100 ft (30 m)	7/8	5/8	7/8	5/8	1-1/8	7/8	1-1/8	7/8	1-1/8	7/8	1-3/8	7/8
150 ft (45 m)	7/8	5/8	7/8	5/8	1-1/8	7/8	1-1/8	7/8	1-1/8	7/8	1-3/8	1-1/8

Consult factory for proper line sizing for runs longer than maximum equivalent length shown.

Source: DPN000788, Rev 16

Table 5.6 Recommended Refrigerant Line Sizes for 4 Step Semi-Hermetic and Digital Scroll Models - OD Copper (Inches)

Model:	035		042		053		070		077 ²		105 ²	
Equivalent Length	Hot Gas Line	Liquid Line	Hot Gas Line	Liquid Line	Hot Gas Line	Liquid Line	Hot Gas Line	Liquid Line	Hot Gas Line	Liquid Line	Hot Gas Line	Liquid Line
50 ft (15 m)	3/4	1/2	7/8	5/8	7/8	5/8	1-1/8 ¹	7/8	1-1/8	7/8	1-3/8	7/8
100 ft (30 m)	7/8	5/8	7/8	5/8	1-1/8 ¹	7/8	1-1/8 ¹	7/8	1-1/8	7/8	1-3/8	7/8
150 ft (45 m)	7/8	5/8	1-1/8 ¹	5/8	1-1/8 ¹	7/8	1-1/8 ¹	7/8	1-1/8	7/8	1-3/8	1-1/8

Consult factory for proper line sizing for runs longer than maximum equivalent length shown.

- Downsize vertical riser one trade size (1-1/8" to 7/8")
- Digital-scroll not available on 077 or 105 models.

Source: DPN000788, Rev 16

5.2.3 Refrigerant Charge Requirements for Air Cooled Systems

The following tables provide the refrigerant charge requirements for the Vertiv™ Liebert® DS , connected piping, and condenser options.

Table 5.7 Approximate R-407C Refrigerant Charge for Air Cooled Liebert® DS

System Type	Model	Charge per Circuit, lb (kg)
Air-cooled	035, 042	5.5 (2.5)
	053, 070, 077	8.0 (3.6)
	105	9.5 (4.3)

Table 5.8 Interconnecting Piping Refrigerant Charge for R-407C, lb per 100 ft (kg per 30 m)

Line Size, O.D., in.	Liquid Line	Hot Gas Line
1/2	6.7 (3.0)	0.5 (0.2)
5/8	10.8 (4.8)	0.8 (0.4)
3/4	16.1 (7.2)	1.2 (0.5)
7/8	22.3 (10.0)	1.7 (0.8)
1-1/8	38.0 (17.0)	2.9 (1.3)
1-3/8	57.9 (25.9)	4.4 (2.0)

Source: DPN003099, Rev. 1

Table 5.9 Approximate R-407C Refrigerant Required per Circuit for Vertiv™ Liebert® DS Condenser

Condenser Model	Per Circuit without Vertiv™ Liebert® Lee-Temp, lb (kg)	Per Circuit with Vertiv™ Liebert® Lee-Temp, lb (kg)
MCS056	2.2 (1.0)	21.0 (9.5)
MCM080	3.0 (1.4)	23.9 (10.8)
MCM160	7.5 (3.4)	44.5 (20.2)
MCL110	5.1 (2.3)	26.0 (11.8)
MCL220	12.2 (5.6)	53.8 (24.4)

Source: DPN002411, Rev. 8

5.2.4 Additional Oil Requirements for Scroll and Digital Scroll Compressors

NOTICE

Risk of improper compressor lubrication. Can cause compressor and refrigerant system damage.

Failure to use oil types, viscosities and quantities recommended by the compressor manufacturer may reduce compressor life and void the compressor warranty.

- Do not mix polyolester (POE) and mineral-based oils.
- Do not mix oils of different viscosities.
- Consult your Vertiv sales representative, visit <https://www.Vertiv.com/en-us/support/>, or contact the compressor manufacturer if questions arise.

System charges may require additional oil charge to be added. See [Additional Oil Requirements for Scroll and Digital Scroll Compressors](#) above, for the amount required for various system charge levels.

In addition to oil added based on system charge, additional oil is required for discharge-line field-installed traps. Standard-formed tube traps are required, see [Standard Formed Tube Trap Versus Straight Tubes and Fittings Trap](#) on page 43 and [Volume of Oil in Standard Form Trap by Pipe Diameter](#) on page 43, because straight tubes and fittings used as traps require much more oil and the length of the straight tube can vary.

With the total calculated refrigerant charge for each circuit, see **Table 5.10** on the next page for the refrigerant charge amount that was calculated and follow that line to the right to see how much additional compressor oil is required for each circuit. Count the numbers of traps in each circuit. See **Table 5.11** on page 43 for the discharge line pipe diameter. Follow the line to the right to see how much oil is needed per trap. Multiply the number of traps per circuit by the Oil volume. Add the additional compressor oil amount and the trap oil volume together. This will be the total amount of oil that will need to be added before the refrigerant is added to each circuit.

On the tag marked “Oil Added Field Service Record,” attached to each compressor, record the date the oil was added and the amount of oil added by field service, including oil added for traps and for system charge per [Additional Oil Requirements for Scroll and Digital Scroll Compressors](#) on the previous page .

Table 5.10 Additional Oil Required per Circuit by System Refrigerant Charge per Circuit

Refrigerant System Charge Per Circuit, lb (kg) *	DS035	DS042	DS053	DS070	DS077	DS105
	Additional Oil Required Per Circuit, oz (ml)					
<40 (18.1)	0	0	0	0	0	0
40 (18.1)	0	0	8 (240)	5 (150)	5 (150)	5 (150)
50 (22.7)	2 (60)	2 (60)	12 (350)	9 (270)	9 (270)	9 (270)
60 (27.2)	4 (120)	4 (120)	16 (470)	13 (380)	13 (380)	13 (380)
70 (31.8)	5.5 (160)	5.5 (160)	20 (590)	17 (500)	17 (500)	17 (500)
80 (36.3)	7 (210)	7 (210)	24 (710)	21 (620)	21 (620)	21 (620)
90 (40.8)	8.5 (250)	8.5 (250)	28 (830)	25 (740)	25 (740)	25 (740)
100 (45.4)	10 (300)	10 (300)	32 (950)	29 (860)	29 (860)	29 (860)
110 (49.9)	11.5 (340)	11.5 (340)	36 (1060)	33 (980)	33 (980)	33 (980)
120 (54.4)	13 (380)	13 (380)	40 (1180)	37 (1090)	37 (1090)	37 (1090)
130 (59.0)	14.5 (430)	14.5 (430)	44 (1300)	41 (1210)	41 (1210)	41 (1210)
140 (63.5)	16 (470)	16 (470)	48 (1420)	45 (1330)	45 (1330)	45 (1330)
150 (68.0)	18 (530)	18 (530)	52 (1540)	49 (1450)	49 (1450)	49 (1450)
160 (72.6)	20 (590)	20 (590)	56 (1660)	53 (1570)	53 (1570)	53 (1570)
170 (77.1)	21.5 (640)	21.5 (640)	60 (1770)	57 (1690)	57 (1690)	57 (1690)
180 (81.6)	23 (680)	23 (680)	64 (1890)	61 (1800)	61 (1800)	61 (1800)
190 (86.2)	24.5 (720)	24.5 (720)	68 (2010)	65 (1920)	65 (1920)	65 (1920)
200 (90.7)	26 (770)	26 (770)	72 (2130)	69 (2040)	69 (2040)	69 (2040)

*System Charge = indoor unit + condenser + refrigerant receiver + refrigerant lines.
 For system charges over 200 lb. (91.7 kg), consult your Vertiv representative.
 Use Copeland POE Oil ULTRA 32-3MAF or other Copeland-approved oils,
 Source: DPN003950 Rev. 6

Figure 5.2 Standard Formed Tube Trap Versus Straight Tubes and Fittings Trap

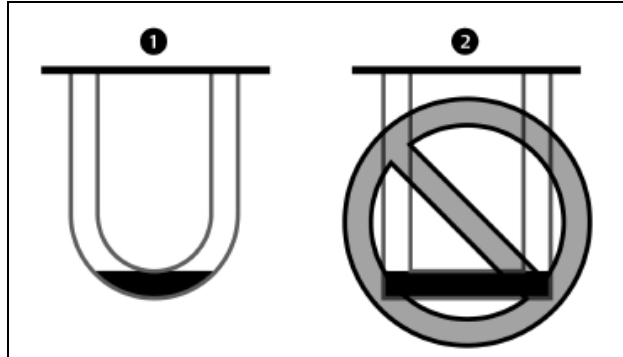

Item	Description
1	Standard-formed tube trap
2	Straight tubes and fittings trap

Table 5.11 Volume of Oil in Standard Form Trap by Pipe Diameter

Pipe diameter, in.	Oil volume, oz
1/2	0.2 (5.9)
5/8	0.4 (11.8)
3/4	0.6 (17.7)
7/8	0.9 (26.6)
1-1/8	1.8 (53.2)
1-3/8	3.3 (97.6)
1-5/8	5.5 (162.7)

Source: DPN003950, Rev. 6

5.2.5 Evacuation, Leak Testing, and Charging Air Cooled Systems without Vertiv™ Liebert® Lee-Temp Receivers

Two discharge lines and two liquid lines must be field-installed between the indoor unit and the outdoor condenser. See the appropriate piping schematic, listed in [Piping General Arrangement Drawings](#) on page 31.

NOTE: Keep the evaporator unit and condenser closed with their factory charge of dry nitrogen while all field piping is installed. Keep the field piping clean and dry during installation. Do not allow it to stand open to the atmosphere. When all the field interconnecting piping is in place, vent each outdoor unit's dry nitrogen charge and connect to the field piping. Finally, vent the evaporator unit's dry nitrogen charge and make its piping connection last. Follow all proper brazing practices, including a dry nitrogen purge to maintain system cleanliness. The condenser connection pipes must be wrapped with a wet cloth to keep the pressure and temperature sensors cool during any brazing.

Evacuation and Leak Testing Air Cooled Systems without Liebert® Lee-Temp

For proper leak-check and evacuation, you must open all system valves and account for all check valves.

NOTE: The system includes a factory-installed additional downstream Schrader valve with core in the compressor discharge line. Proper evacuation of the condenser side of the compressor can be accomplished only using the downstream Schrader valve. See the appropriate piping schematic for your system in the submittal-drawings appendix.

1. If unit power is available, open the unit liquid-line solenoid valves using the evacuation function for System #1 and System #2 in the diagnostic section of the Vertiv™ Liebert® iCOM™ controller.
 - or –
 - If unit power is not available, connect a field supplied 24-VAC/75-VA power source directly to the unit solenoid valve.
2. Connect refrigerant gauges to the suction rotalock valves and discharge-line Schrader valves on both compressors.
3. Starting with Circuit #1, open the service valves and place a 150 PSIG (1034 kPa) of dry nitrogen with a tracer of refrigerant. Check system for leaks with a suitable leak detector.
4. With pressure still in Circuit #1, open the compressor service valves in Circuit #2.
 - If pressure increases in Circuit #2, the system is cross-circuited and must be re-checked for proper piping.
 - If there is no pressure increase, repeat step 3 on Circuit #2.
5. After completion of leak testing, release the test pressure, (observe local code) and pull an initial deep vacuum of 500 microns on the system with a suitable pump.
6. After 4 hours, check the pressure readings and, if they have not changed, break vacuum with dry nitrogen. Pull a second and third vacuum to 500 microns or less. Re-check the pressure after 2 hours.
7. When the 3 checks are complete, proceed to [Charging Air Cooled Systems without Vertiv™ Liebert® Lee-Temp](#) on the facing page.

Break Vacuum

Using a manifold charging hose equipped with a ball valve, properly connect to a tank of refrigerant, and purge the hose with refrigerant to ensure non-condensables do not enter the system. Connect the hose assembly to the liquid line Schrader port and break circuit vacuum with a portion of the calculated refrigerant pre-charge. Add enough refrigerant to bring pressure slightly above positive. Close ball valve and remove refrigerant tank.

Charging Air Cooled Systems without Vertiv™ Liebert® Lee-Temp

NOTICE

Risk of improper refrigerant charging. Can cause equipment damage.

R-407C is a blended refrigerant and must be introduced and charged from the cylinder only as a liquid.

Care must be exercised to avoid damage to the compressor. We recommend connecting a manifold charging hose equipped with a ball valve to the liquid line Schraeder port.

NOTICE

Risk of refrigerant overcharge. Can cause equipment damage.

Do not use the sight glass as an indicator when charging condenser systems.

NOTE: A digital scroll compressor can have a clear unit sight glass on the liquid line only when operating at 100% capacity. When operating below 100%, the unit sight glass may show bubbles with each 15 second unloading cycle.

The system must be fully piped and evacuated before it can be charged. See [Evacuation and Leak Testing Air Cooled Systems without Liebert® Lee-Temp](#) on the previous page .

Liebert® MC condensers are charge-sensitive and require accurate calculation of the system charge to avoid overcharging. To avoid overcharge, the following additional guidelines are recommended to ensure trouble-free operation.

- When charging system in an outdoor ambient below 50°F (10°C), recheck the subcooling against **Table 5.12** on the next page , when the ambient is above 60°F (15.6°C)
- The indoor space should be maintained at 70 to 80°F (21 to 26.7°C) return air before final charge adjustments are made.
- Charging unit at greater than 80°F (26.7°C) return air and low outdoor ambient temperature may result in the unit being overcharged.
- Charge by subcooling measurement at the indoor unit. See **Table 5.12** on the next page , for target subcooling temperatures.
- Pressure and temperature measuring instruments should be capable of measuring to ±10 psig (68.9 kPa) and ± 2°F (1.1°C) for best subcooling measurement.

NOTICE

Units should never be operated with no refrigerant charge, holding charge, proper load, or without additional oil as required. Tag out system to prevent unauthorized personnel from accidentally starting equipment and damaging compressors if any of these conditions exist.

To charge the system:

1. Check the nameplate on the indoor unit for refrigerant type to be used. Unit control configurations differ depending on refrigerant type.
2. Refer to the following if necessary:
 - [Checklist for Completed Installation](#) on page 87 to operate the system.
 - The operating manual for the Vertiv™ Liebert® MC Condenser.

Manuals are available at <https://www.Vertiv.com/en-us/support/>.

3. Calculate the amount of charge for the system. See [Refrigerant Charge Requirements for Air Cooled Systems](#) on page 39 .

4. Add additional compressor and trap oil. See [Additional Oil Requirements for Scroll and Digital Scroll Compressors](#) on page 41.
5. Accurately weigh in as much of the system charge as possible before starting the unit. Do not exceed the calculated charge by more than 0.5 lb (0.23 kg).
6. Close the Liebert® MC disconnect switch.
7. Close the Vertiv™ Liebert® DS disconnect switch.

NOTICE

The unit must have line voltage applied to the unit at least 12 hours before compressor start-up to allow the compressor crankcase heaters time to warm the compressors and boil off any liquid refrigerant in the compressors after pre-charge.

8. In the Service menu of the Vertiv™ Liebert® iCOM™ controller, select *Diagnostics/Service > Diagnostics*:
 - a. *Enable* Manual Mode.

NOTE: Manual Mode will time out after 60 minutes.

- b. In Evaporator Fan options set *Motors* to *On* to operate the fan during Manual Mode.
- c. In Compressor Circuit 1 options, set *Compressor Mode* to *Charge* to operate the compressor at full capacity, energize the liquid-line solenoid valve, and disable reheat and humidifier.
- d. Reset the charge function as many times as needed to complete unit charging.

NOTE: You must establish and maintain a minimum 32 psig (221 kPa) for the compressor to operate.

9. Attach pressure and temperature instruments to the liquid-line of the indoor unit, measure the initial subcooling, and continue to add charge until the recommended subcooling for the current outdoor ambient temperature is reached. See **Table 5.12** below. Read the outdoor ambient temperature from the Liebert® MC condenser control menu ID F02.

NOTE: To determine subcooling measurement, you must measure the liquid-line pressure reading (at the factory-installed Schrader tap) and obtain a temperature reading on the liquid line. Convert the liquid-line pressure reading into a liquid temperature using a Pressure-Temperature Guide or **Table 5.13 on the facing page. Subtract the measured temperature from the saturated-liquid temperature. The difference is subcooling. Make sure to use the saturated liquid temperature to calculate subcooling.**

10. As head pressure builds, the variable-fan-speed controlled condenser fan begins rotating. The fan will run at full speed when sufficient head pressure is developed.

Table 5.12 Target Subcooling for Ambient Outdoor Temperature

Ambient Temp, °F (°C)	Subcooling, °F (°C)
0 (-17.8)	22 (12.0)
10 (-12.2)	22 (12.0)
20 (-6.7)	22 (12.0)
30 (-1.1)	22 (12.0)
40 (4.4)	22 (12.0)
50 (10.0)	21 (11.7)
60 (15.6)	19 (10.8)
70 (21.1)	17 (9.3)

Table 5.12 Target Subcooling for Ambient Outdoor Temperature (continued)

Ambient Temp, °F (°C)	Subcooling, °F (°C)
80 (26.7)	13 (7.2)
90 (32.2)	9 (5.0)
95 (35.0)	7 (3.9)
100 (37.8)	5 (2.9)
105 (40.6)	3 (1.8)
110 (43.3)	1 (0.7)
125 (51.7)	0

Source: DPN002411, Rev. 8

Additional Compressor Oil

Once the circuits are topped off with refrigerant, more compressor oil may need to be added to each circuit if the final charge is over 10 pounds of the calculated refrigerant charge. Record this additional oil amount on the manilla tag hanging on the compressor service valve.

Table 5.13 Liquid Pressure and Temperature Chart—R-407C

Pressure		Temperature*	
PSIG	BarG	°F	°C
170	11.7	81.5	27.5
180	12.4	85.1	29.5
190	13.1	88.6	31.5
200	13.8	92.0	33.3
210	14.5	95.2	35.1
220	15.2	98.3	36.8
230	15.9	101.4	38.5
240	16.6	104.3	40.2
250	17.2	107.2	41.8
260	17.9	109.9	43.3
270	18.6	112.6	44.8
280	19.3	115.3	46.3
290	20.0	117.8	47.7
300	20.7	120.3	49.1
310	21.4	122.8	50.4
320	22.1	125.2	51.8
330	22.8	127.5	53.1
340	23.4	129.8	54.3

Table 5.13 Liquid Pressure and Temperature Chart—R-407C (continued)

Pressure		Temperature*	Temperature*
PSIG	BarG	°F	°C
350	24.1	132.1	55.6
360	24.8	134.3	56.8
370	25.5	136.4	58.0
380	26.2	138.6	59.2
390	26.9	140.6	60.3
400	27.6	142.7	61.5
500	34.5	161.3	71.8
600	41.4	177.4	80.8

* Values are for saturated liquid
 Source: DPN002411, Rev. 8

5.2.6 Evacuation, Leak Testing, and Charging Air Cooled Systems with Vertiv™ Liebert® Lee-Temp “Flooded Condenser” Head Pressure Control System

The Liebert® Lee-Temp system consists of a modulating-type head-pressure control valve and insulated receiver with heater pad to ensure operation at ambient temperatures as low as -30°F (-34.4°C).

Two discharge lines and two liquid lines must be field-installed between the indoor unit and the outdoor condenser. See the appropriate piping schematic, listed in [Piping General Arrangement Drawings](#) on page 31.

NOTE: Keep the evaporator unit, receiver, and condenser closed with their factory charge of dry nitrogen while all field piping is installed. Keep the field piping clean and dry during installation. Do not allow it to stand open to the atmosphere. When all the field interconnecting piping is in place, vent each outdoor unit's dry nitrogen charge and connect to the field piping. Finally, vent the evaporator unit's dry nitrogen charge and make its piping connection last. Follow all proper brazing practices, including a dry nitrogen purge to maintain system cleanliness. The condenser connection pipes must be wrapped with a wet cloth to keep the pressure and temperature sensors cool during any brazing.

Liebert® Lee-Temp Controlled Materials Supplied

- Built-in, pre-wired condenser control box
- Air-cooled condenser
- Piping access cover
- Bolts—4 per leg (3/8 in. x 5/8 in.)
- Terminal block for 2 wire, 24V interlock connection between unit and condenser
- Terminal blocks for shielded, CANbus-cable connection between unit and condenser
- Condenser legs—6 with 2 fan units, 8 with 2, 3, and 4 fan units
- Bolts—6 per receiver (3/8 in. x 1 in.)
- Liebert® Lee-Temp system:
 - Insulated storage receiver with (2) liquid-level sight glasses—1 per circuit
 - Head-pressure control-valve piping assembly with (2) integral check valves—1 per circuit
 - Service valve—1 per receiver
 - Pressure-relief valve—1 per receiver

NOTE: The Liebert® Lee-Temp heater pad requires a separate, continuous electrical source. See nameplate on receiver for proper voltage.

Evacuation and Leak Testing Air Cooled Systems with Liebert® Lee-Temp Receiver

For proper leak check and evacuation, you must open all system valves and account for all check valves.

NOTE: The system includes a factory-installed additional downstream Schrader valve with core in the compressor discharge line. Proper evacuation of the condenser side of the compressor can be accomplished only using the downstream Schrader valve. See the appropriate piping schematic for your system in Submittal Drawings on page 147

1. If unit power is available, open the unit liquid-line solenoid valve using the evacuation function in the diagnostic section of the Vertiv™ Liebert® iCOM™ control.
– or –
If unit power is not available, connect a field-supplied 24-VAC/75-VA power source directly to the unit solenoid valve.
2. Connect a jumper hose from the service-valve fitting on the outlet of the receiver and the Schrader fitting on the discharge header of the condenser. Seat the service valve approximately two turns from the fully back-seated position.
3. On both compressors, connect refrigerant gauges to the suction rotalock valves and discharge-line Schrader valves.
4. Starting with Circuit #1, open the service valves and place a 150 PSIG (1034 kPa) of dry nitrogen with a tracer of refrigerant. Check system for leaks with a suitable leak detector.
5. With pressure still in Circuit #1, open the compressor service valves in Circuit #2.
 - If pressure increases in Circuit #2, the system is cross-circuited and must be re-checked for proper piping.
 - If there is no pressure increase, repeat step 4 on Circuit #2.
6. After completion of leak testing, release the test pressure, (observe local code) and pull an initial deep vacuum of 500 microns on the system with a suitable pump.
7. After 4 hours, check the pressure readings and, if they have not changed, break vacuum with dry nitrogen. Pull a second and third vacuum to 500 microns or less. Re-check the pressure after 2 hours.
When the 3 checks are complete, remove the jumper hose from the service-valve fitting and the condenser, and proceed to [Charging Air Cooled Systems with Vertiv™ Liebert® Lee-Temp Receiver](#) on the facing page .

Break Vacuum

Using a manifold charging hose equipped with a ball valve, properly connect to a tank of refrigerant, and purge the hose with refrigerant to ensure non-condensables do not enter the system. Connect the hose assembly to the liquid line Schrader port and break circuit vacuum with a portion of the calculated refrigerant pre-charge. Add enough refrigerant to bring pressure slightly above positive. Close ball valve and remove refrigerant tank.

Charging Air Cooled Systems with Vertiv™ Liebert® Lee-Temp Receiver

NOTICE

Risk of improper refrigerant charging. Can cause equipment damage.

R-407C is a blended refrigerant and must be introduced and charged from the cylinder only as a liquid.

Care must be exercised to avoid damage to the compressor. We recommend connecting a manifold charging hose equipped with a ball valve for the liquid line Schraeder port.

NOTICE

Units should never be operated with no refrigerant charge, holding charge, proper load, or without additional oil as required. Tag out system to prevent unauthorized personnel from accidentally starting equipment and damaging compressors if any of these conditions exist.

To charge the system:

1. Check the nameplate on the indoor unit for refrigerant type to be used. Unit control configurations differ depending on refrigerant type.
2. Refer to [Checklist for Completed Installation](#) on page 87.
3. Calculate the amount of charge for the system. See [Refrigerant Charge Requirements for Air Cooled Systems](#) on page 39.
4. Add additional compressor and trap oil. See [Additional Oil Requirements for Scroll and Digital Scroll Compressors](#) on page 41.
5. Accurately weigh in as much of the system charge as possible before starting the unit.
6. Close the Vertiv™ Liebert® MC disconnect switch.
7. Close the Vertiv™ Liebert® DS disconnect switch.

NOTICE

The unit must have line voltage applied to the unit at least 12 hours before compressor start-up to allow the compressor crankcase heaters time to warm the compressors and boil off any liquid refrigerant in the compressors after pre-charge.

8. In the Service menu of the Vertiv™ Liebert® iCOM™ controller, select *Diagnostics/Service > Diagnostics*:
 - a. *Enable Manual Mode*.

NOTE: Manual Mode will time out after 60 minutes.

- b. In Evaporator Fan options set *Motors* to *On* to operate the fan during Manual Mode.
- c. In Compressor Circuit 1 options, set *Compressor Mode* to *Charge* to operate the compressor at full capacity, energize the liquid-line solenoid valve, and disable reheat and humidifier.
- d. Reset the charge function as many times as needed to complete unit charging.

NOTE: You must establish and maintain a minimum 32 psig (221 kPa) for the compressor to operate.

- e. Repeat step 8 for Compressor Circuit 2.

9. Check the refrigerant level in the refrigerant-level sight glass on each Vertiv™ Liebert® Lee-Temp receiver after the unit has been operating for at least 15 minutes.

NOTE: Each receiver at the condenser has 2 sight glasses and the refrigerant level varies with outside temperature.

10. Adjust the refrigerant level in each circuit to meet the level shown in [Target Refrigerant Level in Sight Glasses at Outdoor Temperatures](#) below .
11. After adjusting the refrigerant, allow the system to operate an additional 15 minutes before checking for the need of further adjustment.

NOTE: A digital-scroll compressor can have a clear unit sight glass on the liquid line only when operating at 100% capacity. When operating with a receiver, the unit sight glass might not become clear even when operating at 100% capacity. When operating below 100%, the unit sight glass may show bubbles with each 15-second unloading cycle.

Target Refrigerant Level in Sight Glasses at Outdoor Temperatures

- 40°F (4.5°C) and lower—bottom sight glass is 3/4 full
- 40 to 60°F (4.5 to 15.5°C)—bottom sight glass is full
- 60°F (15.5°C) and higher—top sight glass is 3/4 full

Additional Compressor Oil

Once the circuits are topped off with refrigerant, more compressor oil may need to be added to each circuit if the final charge is over 10 pounds of the calculated refrigerant charge. Record this additional oil amount on the manilla tag hanging on the compressor service valve.

5.3 Refrigerant Charge for Water/Glycol Cooled Systems

The water/glycol cooled system is factory-charged and includes and includes a Vertiv™ Liebert® Paradenser Condenser and control valves. The unit will operate without refrigerant charge adjustment at a wide range of return air temperatures and water/glycol entering temperatures. Adjusting the factory refrigerant charge while operating the unit at full load room conditions and at typical water/glycol temperatures can maximize the cooling capacity and unit efficiency.

Table 5.14 Approximate R-407C Refrigerant Factory Charge for Water/Glycol Cooled Vertiv™ Liebert® DS

System Type	Model	Charge per Circuit, lb (kg)
Water, Glycol/GLYCOOL	035, 042	12.2 (5.6)
	053, 070, 077	17.0 (7.8)
	105	22.5 (10.3)

To optimize the refrigerant charge:

1. Operate the unit at full heat load, normal room conditions and normal water/glycol fluid temperatures for a minimum of 30 minutes before measuring stable unit superheat and subcooling temperatures and adjusting charge levels.
 - Condensing temperatures should be in range of 100 to 130°F (38 to 54°C) depending on fluid type and fluid temperature.
 - Full heat load is required to stabilize the system and prevent digital scroll compressors from modulating.

2. Attach pressure and temperature instruments to the liquid line of the indoor unit. Use the factory installed Schrader valve located in the liquid line downstream of the condenser. Measure the initial subcooling.

NOTE: To determine subcooling measurement, a liquid line pressure reading (at the factory installed Schrader tap) must be measured along with the temperature reading on the liquid line. Convert the liquid line pressure reading into a liquid temperature by utilizing a pressure temperature guide or **Table 5.13 on page 47. Subtract the measured temperature from the liquid saturation temperature. The difference is subcooling.**

3. Adjust refrigerant charge levels as needed to achieve subcooling range of 12 to 14°F (6.7 to 7.8°C) while maintaining full load conditions.

Table 5.15 Water/Glycol Cooled and Vertiv™ Liebert® GLYCOOL Suction Pressure Transducer Settings

Function	R-407C	
	Gauge (Sea Level) PSIG (kPa)	Absolute psiA (kPa)
Minimum to Start-Cooling	50 (345)	65 (448)
Freeze Protection (DX w/Econ-o-Coil)	52 (358)	67 (461)

5.4 Water/Glycol Loop Piping Guidelines



CAUTION: Risk of improper piping installation, leak checking, fluid chemistry and fluid maintenance. Can cause injury. Building and equipment damage may also result. Installation and service of this equipment should be done only by qualified personnel who have been specially-trained in the installation of air-conditioning equipment and who are wearing appropriate, OSHA-approved PPE.

NOTICE

Risk of piping-system corrosion and freezing fluids. Can cause leaks resulting in equipment and expensive building damage. Cooling coils, heat exchangers and piping systems are at high risk of freezing and premature corrosion. Fluids in these systems must contain an inhibitor to prevent premature corrosion.

The system coolant fluid must be analyzed by a competent fluid-treatment specialist before start up to establish the inhibitor level and evaluated at regularly scheduled intervals throughout the life of the system to determine the pattern of inhibitor depletion. The fluid complexity and variations of required treatment programs make it extremely important to obtain the advice of a competent and experienced fluid-treatment specialist and follow a regularly scheduled coolant-fluid system-maintenance program.

Fluid chemistry varies greatly as do the required additives, called inhibitors, that reduce the corrosive effect of the fluids on the piping systems and components.

The chemistry of the coolant fluid used must be considered, because some sources may contain corrosive elements that reduce the effectiveness of the inhibited formulation. Sediment deposits prevent the formation of a protective oxide layer on the inside of the coolant system components and piping. The coolant fluid must be treated and circulating through the system continuously to prevent the buildup of deposits and/or growth of bacteria. Proper inhibitor maintenance must be performed to prevent corrosion of the system.

Consult fluid manufacturer for testing and maintenance of inhibitors.

Commercial-grade coolant fluid is generally less corrosive to the common metals of construction than water itself. It will, however, assume the corrosivity of the coolant fluid from which it is prepared and may become increasingly corrosive with use if not properly inhibited.

Vertiv recommends installing a monitored fluid-detection system that is wired to activate the automatic-closure of field-installed coolant-fluid supply and return shut-off valves to reduce the amount of coolant-fluid leakage and consequential equipment and building damage. The shut-off valves must be sized to close-off against the maximum coolant-fluid system pressure in case of a catastrophic fluid leak.

NOTICE

Risk of no-flow condition. Can cause equipment damage.

Do not leave the water/coolant fluid-supply circuit in a no-flow condition. Idle fluid allows the collection of sediment that prevents the formation of a protective oxide layer on the inside of tubes. Keep unit switched On and water/coolant fluid-supply circuit system operating continuously.

Refer to the appropriate piping general-arrangement schematics for your system for the recommended, field-installed hardware such as shut-off valves. See **Table 5.1** on page 31.

- Use copper piping with a brazing alloy with a minimum temperature of 1350°F (732°C), such as Sil-Fos. Avoid soft solders, such as 50/50 or 95/5.
- Follow local piping codes and safety codes.
- Qualified personnel must install and inspect system piping.
- The water/glycol-cooled system will operate in conjunction with a cooling tower, city water or drycooler.
- Contact a local water consultant regarding water quality, corrosion protection and freeze-protection requirements.
- Install manual shut-off valves at the supply and return line to each indoor unit and drycooler to permit routine service and emergency isolation of the unit.
- Install a monitored, fluid-detection system that is wired to activate the automatic closure of field installed coolant-fluid supply and return shut-off valves to reduce the amount of coolant fluid leakage and consequential equipment and building damage. The shut-off valves must be sized to close-off against the maximum coolant-fluid system pressure in case of a catastrophic fluid leak.

5.4.1 Leak Checking for Unit and Field Installed Piping

The fluid systems in the Vertiv™ Liebert® DS are factory-checked for leaks and may be shipped with an inert-gas holding charge. At installation, check all fluid circuits for leaks.

NOTE: We recommend isolating the unit with field-installed shutoff valves during leak checking of field-installed piping. When the units are included in a leak test, use of fluid for pressure testing is recommended. When pressurized gas is used for leak testing the unit, the maximum recommended pressure is 30 psig (207 kPa) and tightness of the unit should be verified by pressure decay over time, (<2 psig/hour [13.8 kPa/hour]) or sensing a tracer gas with suitable instrumentation. Dry seals in fluid valves and pumps may not hold a high gas pressure.

6 Electrical Connections

Three-phase electrical service is required for all models. Electrical service must conform to national and local electrical codes. Refer to equipment nameplate regarding wire size and circuit protection requirements. Refer to electrical schematic when making connections. Refer the appropriate submittal drawing, listed in [Electrical Field-connection Drawings](#) on the next page, for electrical service entrances into unit.

A manual electrical disconnect switch should be installed in accordance with local codes and distribution system. Consult local codes for external disconnect requirements.



WARNING! Arc flash and electric shock hazard. Can cause serious injury or death. Building and equipment damage may also result. Disconnect all local and remote electric power supplies and wear appropriate, OSHA-approved personal protective equipment (PPE) per NFPA 70E before working within the electric control enclosure. Customer must provide earth ground to unit, per NEC, CEC and local codes, as applicable.

Verify with a voltmeter that power is Off. The Vertiv™ Liebert® iCOM™ controller does not isolate power from the unit, even in the “Unit Off” mode. Some internal components still require and receive power even during the “Unit Off” mode of the Liebert® iCOM™ controller. The factory-supplied, optional disconnect switch is inside the unit. The line side of this switch contains live high voltage. The only way to ensure that there is NO voltage inside the unit is to install and open a remote disconnect switch. Refer to unit electrical schematic.

Before proceeding with installation, read all instructions, verify that all the parts are included and check the nameplate to be sure the voltage matches available utility power. Follow all local codes.



WARNING! Risk of electric shock. Can cause serious injury or death. Building and equipment damage may also result. Open all local and remote electric power supply disconnect switches and verify that power is off with a voltmeter before working within any electric connection enclosures. The Liebert® iCOM™ controller does not isolate power from the unit, even in the "Unit Off" mode. Some internal components require and receive power even during the "unit off" mode of the Liebert® iCOM™ controller .

Installation, service, and maintenance work must be performed only by properly trained and qualified personnel and in accordance with applicable regulations and manufacturers' specifications. Opening or removing the covers to any equipment may expose personnel to lethal voltages within the unit even when it is apparently not operating and the input wiring is disconnected from the electrical source.

NOTE: Seal openings around piping and electrical connection to prevent air leakage. Failure to do so could reduce the unit's cooling performance.



WARNING! Risk of short circuits and electric shock. Can cause serious injury or death. Building and equipment damage can result from cut insulation or damaged wires. Can cause overheated wiring, smoke, fire, activation of fire suppression systems and EMS personnel, and loss of power to fans. Verify that all wiring connections are tight and that all wiring is contained within the junction box prior to closing and securing the cover.

Insert CSA-certified or UL-listed bushings into holes and/or knockouts used to route wiring through metal panels to protect the wire insulation from contact with sheet metal edges.



WARNING! Risk of improper wire sizing/rating and loose electrical connections causing overheated wire and electrical connection terminals resulting in smoke or fire. Can cause serious injury or death. Building and equipment damage may also result. Use correctly sized copper wire only and verify that all electrical connections are tight before turning power On. Check all electrical connections periodically and tighten as necessary.

NOTICE

Risk of improper electrical connection of three-phase input power. Can cause backward compressor rotation and unit damage. Service technicians should use a gauge set on the system during the initial start up to verify that the three-phase power is connected properly. The EC fans are not a reliable indicator of proper connection. The blowers will rotate the same direction, regardless of the three-phase power input. Three-phase power must be connected to the unit line voltage terminals in the proper sequence so that the compressors rotate in the proper direction. Incoming power must be properly phased to prevent compressors from running backward. We recommend checking the unit’s phasing with proper instrumentation to ensure that power connections were made correctly. We also recommend verifying discharge and suction pressures during start up to ensure that the compressors are running in the correct direction.

NOTICE

Risk of improper power-supply connection. Can cause equipment damage and loss of warranty coverage.

Prior to connecting any equipment to a main or alternate power source (for example: back-up generator systems) for start-up, commissioning, testing, or normal operation, ensure that these sources are correctly adjusted to the nameplate voltage and frequency of all equipment to be connected. In general, power-source voltages should be stabilized and regulated to within ±10% of the load nameplate nominal voltage. Also, ensure that no three-phase sources are single-phased at any time.

See transformer label for primary tap connections. Installer will need to change transformer primary taps if applied unit voltage is other than pre-wired tap voltage.

The electrical connections are described in the submittal documents included in the [Submittal Drawings](#) on page 147.

The following tables list the relevant documents by number and title.

Table 6.1 Electrical Field-connection Drawings

Document Number	Title
DPN004352	Electrical Field Connection Description Upflow and Downflow Models
DPN003267	CANbus and Interlock Connections between Liebert® DS and Liebert® MC Condenser (Premium)

7 EC Fans and Plenums

Depending on the air-distribution options of your unit, you may have EC fans and/or plenums to install.

7.1 Downflow Units with EC Fans

Vertiv™ Liebert® DS downflow models are equipped with EC fans that may operate in the fully-raised position or lowered into the floor stand for increased efficiency from reduced air resistance.



WARNING! Risk of extremely heavy fan modules dropping downward suddenly. Can cause serious injury or death. Building and equipment damage may also result. Fan modules weigh in excess of 125-lb (56.7-kg) each. Support fan modules before removing mounting hardware. Use caution to keep all body parts out of the fan module pathway of movement during removal or repositioning. Only properly trained and qualified personnel should work on this equipment.

More than one person may be required to complete the assembly and installation. Installer(s) must be properly trained and qualified to lift, move and manipulate very heavy equipment from floor level to the top of the unit. Wear appropriate, OSHA-approved PPE when moving, lifting, installing, and removing the fan(s) and plenum. Read and follow the lifting equipment and/or ladder manufacturer's operating instructions and safety requirements.



CAUTION: Risk of improper handling heavy and lengthy parts. Can cause injury. Building and equipment damage may also result. Cabinet panels can exceed 5 ft. (1.5 m) in length and weigh more than 35 lb (15.9 kg). Follow relevant OSHA lifting recommendations and consider using a two-person lift for safe and comfortable removal and installation of cabinet panels. Only properly trained and qualified personnel wearing appropriate, OSHA-approved PPE should attempt to remove or install cabinet panels.

NOTE: Use fans either in their original raised position or with the fans in their fully-lowered position. Suspension of fans in an intermediate position will directly affect product performance and is not recommended.

7.1.1 Lowering the EC Fans into the Floor Stand on Downflow Models

NOTE: If your floor-stand height is between 9 in. (228.6 mm) and 21 in. (533.5 mm), please contact the factory before attempting to lower the fans into the floor stand. If the floor-stand height is 24 in. (609.6 mm) up to 48 in. (1219.2 mm), the fans can be installed and lowered into the floor stand.

Tools Needed

- 1/2-in. hex socket and wrench
- Factory-supplied jack, crank and jack support
- Cable tie cutter

To lower the fans:

1. Remove the middle and bottom panels from the front of the unit.
2. For ease of fan lowering, We recommend removing the infrared humidifier.
3. Position the factory-supplied jack and jack support under the fan to be lowered.
4. Raise the jack to safely support the fan before removing any hardware.

NOTE: The jack should be centered between the first and second set of tabs on the jack support (see Detail A in Figure 7.1 below).

5. Cut and remove the cable tie that holds the wiring loop to the blower mounting plate. All other cable ties that route the fan wiring should remain intact.
6. Remove the six 1/2" hex head screws. Retain the hardware for later use.

Figure 7.1 Lowering EC Fans into Floor Stand, Steps 1 through 6

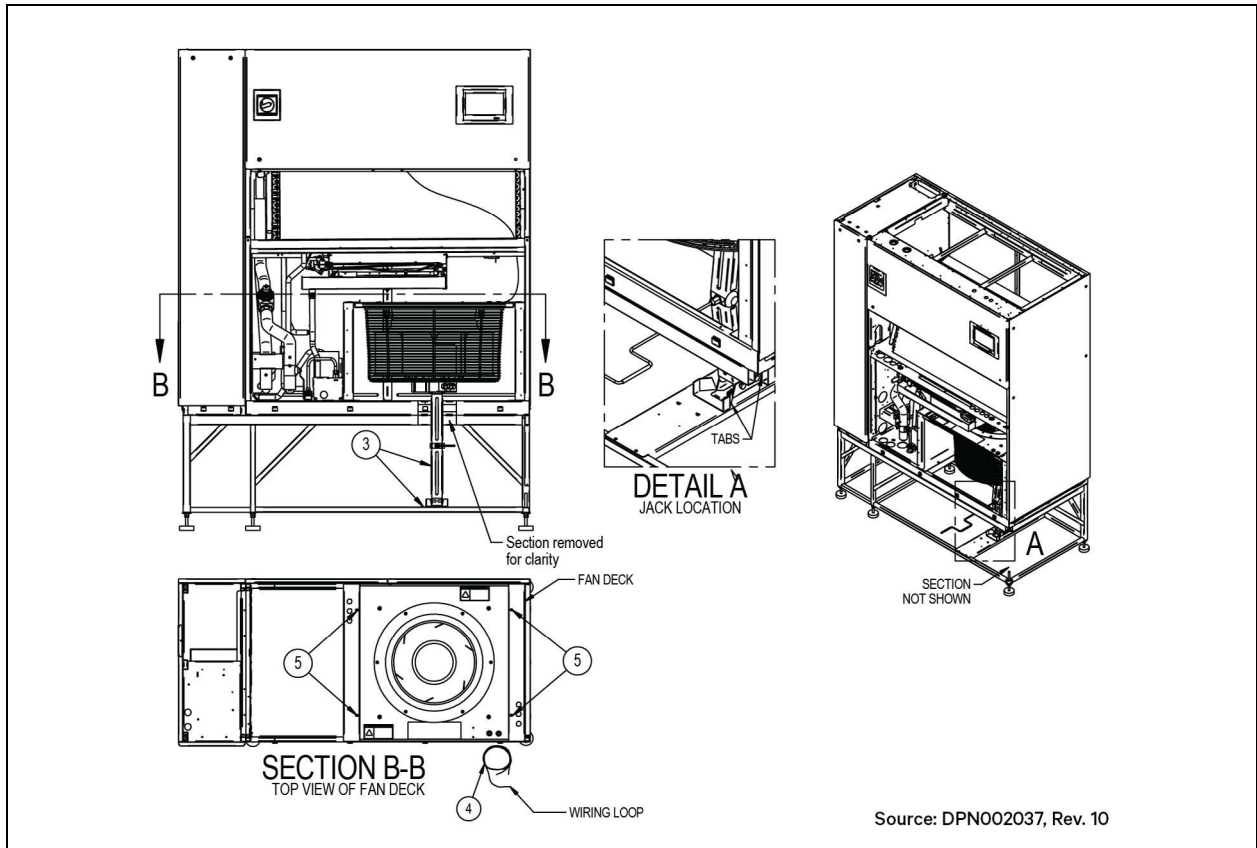

- Using the jack, lower the fan module slowly until it rests on the frame of the unit.

NOTICE

Risk of equipment snagging cables and wiring. Can damage the unit wiring and components.

Carefully monitor the position of the EC-fan wire harnesses and other parts while lowering the fan to be sure that they are not caught or pinched.

- Secure the fan module in the fully lowered position by reinstalling the hex head screws directly to the frame. Screw clearance holes are provided in the fan module.

NOTE: Not all hardware retained will be used to secure the fans in the lowered positioned.

- Repeat steps 3 through 8 to lower remaining fan modules.

Figure 7.2 Lowering EC Fans into Floor, Steps 7 through 8

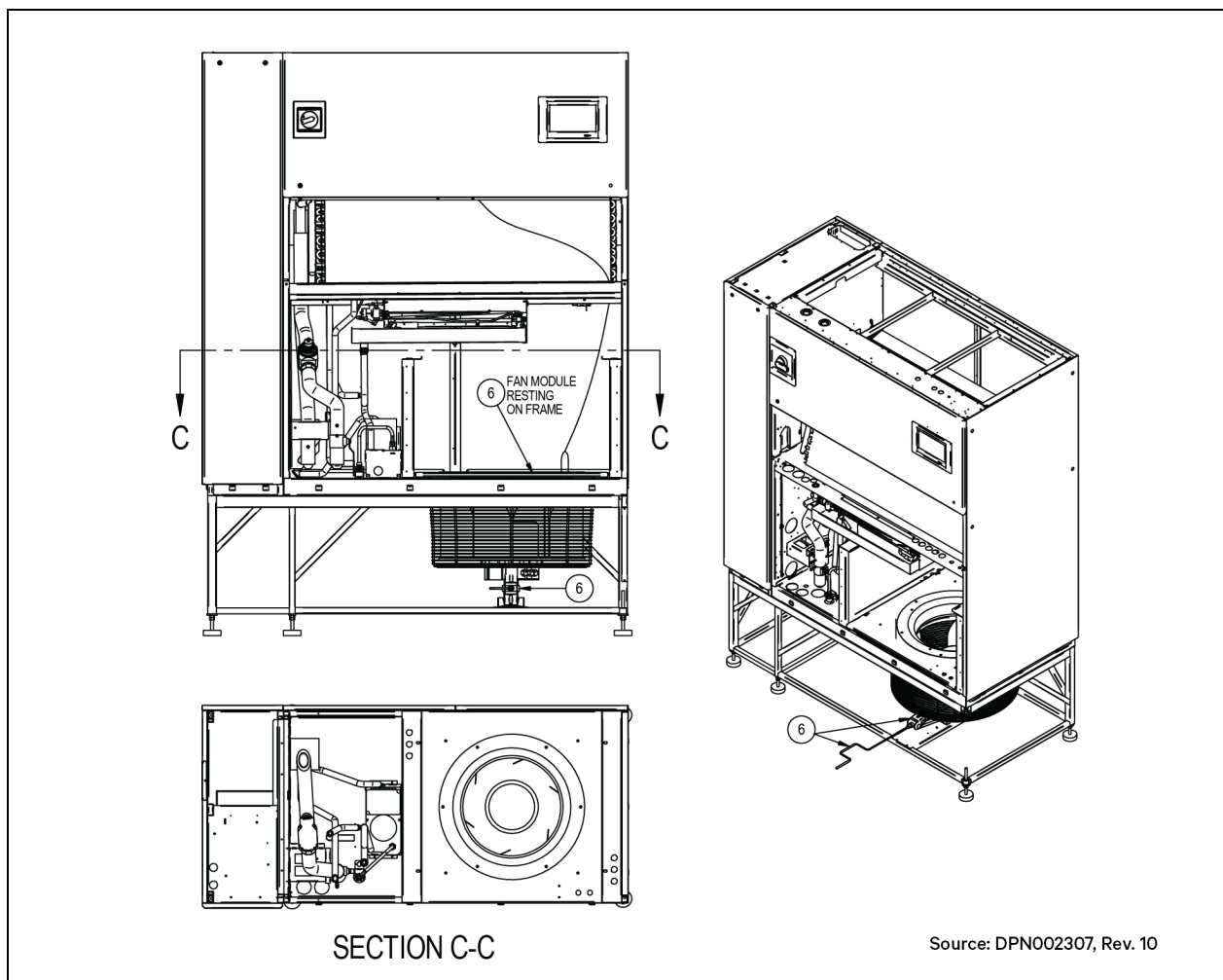

7.2 Upflow Unit Plenums with EC Fans

EC fans on upflow units are mounted external to the unit in a factory-provided plenum. The plenum distributes air to the conditioned space through adjustable, double-deflection grilles, or connects with field-supplied duct work.

Read all instructions before installing plenums and EC fans.



WARNING! Risk of electric shock. Can cause serious injury or death. Open all local and remote electric power supply disconnect switches and verify that power is off with a voltmeter before working within any electric connection enclosures. The Vertiv™ Liebert® iCOM™ controller does not isolate power from the unit, even in the "Unit Off" mode. Fan-motor controls can maintain an electric charge for 10 minutes after power is disconnected. Wait 10 minutes after power is verified as off before working within the electric control/connection enclosures.

Installation, service, and maintenance work must be performed only by properly trained and qualified personnel and in accordance with applicable regulations and manufacturers' specifications. Opening or removing the covers to any equipment may expose personnel to lethal voltages within the unit even when it is apparently not operating and the input wiring is disconnected from the electrical source.



WARNING! Risk of contact with high-speed rotating fan blades. Can cause serious injury or death. Open all local and remote electric power-supply disconnect switches, verify with a voltmeter that power is off, and verify that all fan blades have stopped rotating before working in the unit cabinet or on the fan assembly. If control voltage is applied, the fan motor can restart without warning after a power failure. Do not operate the unit with any or all cabinet panels removed.

Do not operate upflow units without installing a plenum, ductwork or guard over the blower opening(s) on the top surface of the unit cabinet.

Ductwork must be connected to the blower(s) or a plenum must be installed on the blower deck for protection from rotating blower wheel(s) on upflow units.



WARNING! Risk of contact with sharp edges, exposed fasteners, and improper handling of very heavy parts. Can cause serious injury or death. Building and equipment damage may also result. Use extreme caution, wear appropriate, OSHA-approved PPE, and install the EC fan(s) and plenum to the unit only as described in these instructions.

More than one person may be required to complete the assembly and installation. Installer(s) must be properly trained and qualified to lift, move and manipulate very heavy equipment from floor level to the top of the unit.

Wear appropriate, OSHA-approved PPE when moving, lifting and installing the fan(s) and plenum.

Equipment used in moving, lifting and installing the fan(s) and plenum must meet OSHA requirements and be rated for the weight of the fan(s) and the plenum. If ladders are used, verify that they are rated for the combined weight of the fan(s), plenum and installer(s) as loaded. EC Fan and plenum weights are specified in **Table 7.1** on the facing page and **Table 7.2** on page 62 .

Read and follow the lifting equipment and/or ladder manufacturer's operating instructions and safety requirements.

NOTE: Grilled plenums are intended for use in upflow configurations only. Non-grilled plenums provide service access on upflow units with duct work.

NOTE: We recommend using a duct lift or scissors lift when installing the EC-fan assemblies on top of the unit.

Figure 7.3 Equipment recommended to install the upflow plenum and EC fans

- Ladders
- Over-head winch or crane
- Duct lift
- Lift chains with hooks
- Scissor lift

7.2.1 Assembly Inspection

1. Inspect all items for visible or concealed damage. Immediately report any damage to the carrier and file a damage claim, sending a copy of the claim to your local sales representative.
2. Move to the installation location, remove items from packaging and verify that the assembly number is correct:
 - Refer to **Table 7.1** below to verify plenum number by unit length, plenum height, quantity, and grille size.
 - If a compressor-section plenum is included, refer to **Table 7.4** on page 65 to verify plenum number by size.
 - Refer to **Table 7.2** on the next page to verify EC fan number by unit voltage.
 - Verify that the fan-motor voltage rating is appropriate for the marked voltage rating of the cooling unit.
3. Verify that all assembly contents are present:
 - Refer to **Figure 7.4** on page 63 and **Table 7.3** on page 64 to verify plenum parts.
 - If a compressor-section plenum is included, refer to **Figure 7.5** on page 65 and **Table 7.4** on page 65 to verify plenum parts.
 - Refer to on page 66 to verify EC-fan parts.

Table 7.1 Plenum Assembly Numbers, Plenum Heights, Plenum Weights and Unit Lengths

Plenum Height:	24 in. (610 mm)	30 in. (762 mm)	36 in. (917 mm)
Unit Description	Assembly Number and Weight		
VS105, Unit Length 132 in. (3353 mm)			
Non-grilled plenum, length 105 in. (2673 mm)	311666G1 - 131 lb (59 kg)	311666G2 - 162 lb (74 kg)	311666G3 - 188 lb (85 kg)
Front discharge, length 105 in. (2673 mm)	311776G1 - 206 lb (93 kg)	—	—
Rear discharge, length 105 in. (2673 mm)	31230G1 - 220 lb (100 kg)	—	—
VS053-077, Unit Length 109 in. (2769 mm)/98 in. (2489 mm)			
Non-grilled plenum, length 82 in. (2089 mm)	312208G1 - 112 lb (51 kg)	312208G2 - 136 lb (62 kg)	312208G3 - 156 lb (71 kg)
Front discharge, length 82 in. (2089 mm)	31298G1 - 160 lb (73 kg)	—	—
Rear discharge, length 82 in. (2089 mm)	312411G1 - 173 lb (79 kg)	—	—
VS028-042, Unit Length 73 in. (1854 mm)/86 in. (2184 mm)			

Table 7.1 Plenum Assembly Numbers, Plenum Heights, Plenum Weights and Unit Lengths (continued)

Plenum Height:	24 in. (610 mm)	30 in. (762 mm)	36 in. (917 mm)
Unit Description	Assembly Number and Weight		
Non-grilled plenum, length 59 in. (1505 mm)	313077G1 - 85 lb (39 kg)	313077G2 - 105 lb (48 kg)	313077G3 - 123 lb (56 kg)
Front discharge, length 59 in. (1505 mm)	312980G1 - 126 lb (57 kg)	—	—
Rear discharge, length 59 in. (1505 mm)	313025G1 - 129 lb (59 kg)	—	—

Table 7.2 EC-fan Assembly Numbers, Weights and Voltage

Assembly no. and weight	Fan size (Nominal)	Voltage / kW	Unit Size
312583G1 - 93 lb (42 kg)	20 in. (500 mm)	460 V / 2.5 kW	VS105
312583G2 - 93 lb (42 kg)		208 V / 2.7 kW	VS105
312583G3 - 102 lb (46 kg)	22 in. (560 mm)	460 V / 3.1 kW	VS053 / 070 / 077
312583G4 - 102 lb (46 kg)		208 V / 2.9 kW	
312583G5 - 119 lb (54 kg)	25 in. (630 mm)	460 V / 2.8 kW	VS028 / 035
312583G6 - 119 lb (54 kg)		208 V / 2.9 kW	
312583G7 - 141 lb (64 kg)		460 V / 4.0 kW	VS042

Plenum Parts Identification

Figure 7.4 Plenum Parts Identification

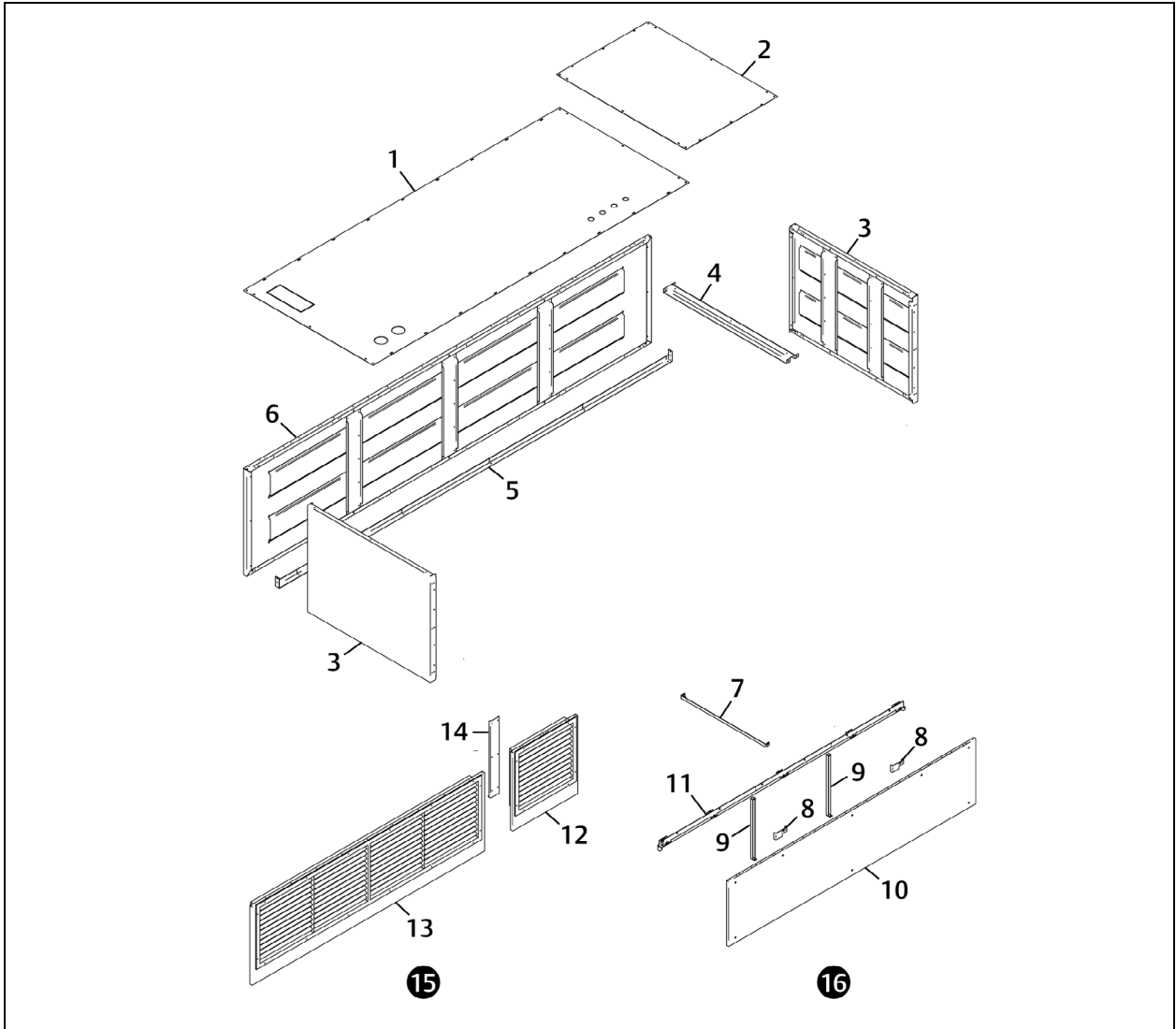

NOTE: Not all parts are used in all models:

- Units shorter than 132 in. (3353 mm) do not include short front and rear grilled panels or channel panels.
- Only non-grilled plenums on 132-in. (3353-mm) units include a plenum brace.
- Units shorter than 132 in. (3353 mm) have only 1 top panel (with holes).
- Front-discharge units do not include a top frame or channel frames. 86-in. (2184 mm) and 73-in. (1854 mm) units do not include channel frames or panel-mounting brackets.

Table 7.3 Plenum Parts and Quantities

Item	Description	Quantity
1	Top panel (with holes)	1
2	Top panel (plain)	1
3	Side panel	2
4	Top-panel brace (Non-grilled plenum)	1
5	Angle bracket, 59-in. - 105-in.	1
6	Front/Rear solid panel	1
7	Top-panel brace (Rear-discharge plenum)	1
8	Panel mounting bracket	1 or 2
9	Channel frame	varies
10	Front solid panel	1
11	Top frame	1
12	Short front grilled panel	1
13	Front grilled panel	1
14	Channel panel	1 or 2
15	Assembly view of long and short front/rear grilled panels	N/A
16	Assembly view of front solid panel.	N/A
Not shown	Angle bracket	varies
Not shown	Washer 1/4	varies
Not shown	Bolt 1/4-20 x 1	varies
Not shown	Sheet-metal screw #8-18 x 1/2	varies
Not shown	Insulation tape	varies

Compressor Plenum Parts Identification

Table 7.4 Compressor Plenum Assembly Numbers, Weights and Size

Assembly no. and weight	Plenum size, in. (mm)
313202G1 - 33 lb (15 kg)	26 x 24 (660 x 610)
313202G2 - 37 lb (17 kg)	26 x 30 (660 x 762)
313202G3 - 42 lb (19 kg)	26 x 36 (660 x 914)
313202G4 - 26 lb (12 kg)	15 x 24 (381 x 610)
313202G5 - 29 lb (13 kg)	15 x 30 (381 x 762)
313202G6 - 31 lb (14 kg)	15 x 36 (381 x 914)
313202G7 - 24 lb (11 kg)	13 x 24 (330 x 610)
313202G8 - 26 lb (12 kg)	13 x 30 (330 x 762)
313202G9 - 29 lb (13 kg)	13 x 36 (330 x 914)
313202G10 - 27 lb (11 kg)	17 x 24 (432 x 610)
313202G11 - 30 lb (14 kg)	17 x 30 (432 x 762)
313202G12 - 33 lb (15 kg)	17 x 36 (432 x 914)

Figure 7.5 Compressor Plenum Parts Identification

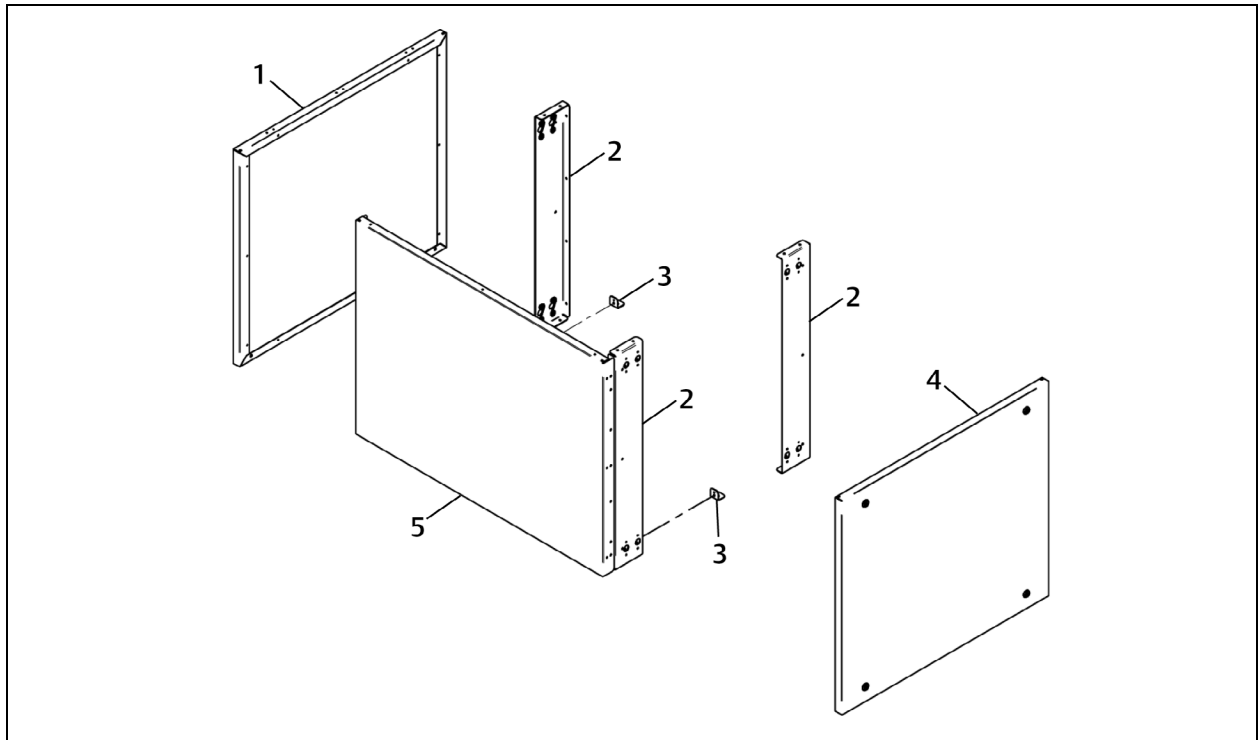

NOTE: Not all parts are used in all plenum sizes: 26 in. (660mm) wide compressor plenums include 3 angle-mounting brackets and a front panel with quarter-turn fasteners.

NOTE: Compressor plenums shorter than 26 in. (660mm) include 2 angle mounting brackets and do not include a front panel with quarter-turn fasteners.

Table 7.5 Compressor plenum parts and quantities

Item	Description	Quantity
1	Front/Rear panel	1 or 2
2	Angle-mounting channel	2 or 3
3	Angle-mounting bracket	2
4	Front panel with quarter-turn fasteners	1
5	Side panel	1
Not shown	Sheet-metal screw	varies

EC Fan Parts Identification

Figure 7.6 EC Fan Assembly

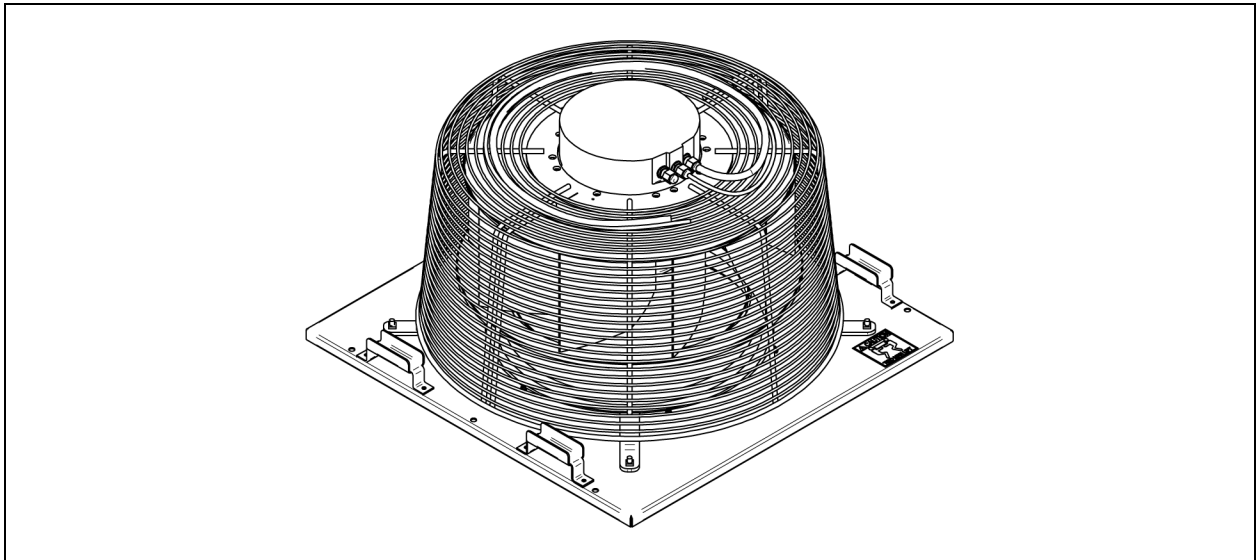

Item	Description	Quantity
Not shown	Washer	6
Not shown	Bolt	6
Not shown	Spacer	6

7.2.2 Assemble Plenum Rear and Side Panels

NOTE: Grilles can be installed on different sides of the plenum depending on discharge configuration. Verify grill location and install according to facility-layout plans.

NOTE: Electrical connections and some piping connections are made through the plenum. Plan accordingly.

1. Apply factory-supplied gasket/insulation tape to plenum panels, **Figure 7.7** on the next page :
 - On front solid panels install the gasketing on the inner edge of the sides, and along the top and bottom edges.
 - On front and rear gridded panels, install the gasketing on the inner edge of the sides, and along the top and bottom edges, except on 105-in. (2673-mm) plenums, do not install gasketing along the edges where the short and long panel connect.
 - On rear solid panels, install the gasketing on the inner edge of the sides and along the bottom edge only.
 - On side panels, install the gasketing along the bottom edge.

Figure 7.7 Apply Gasket/Insulation Tape

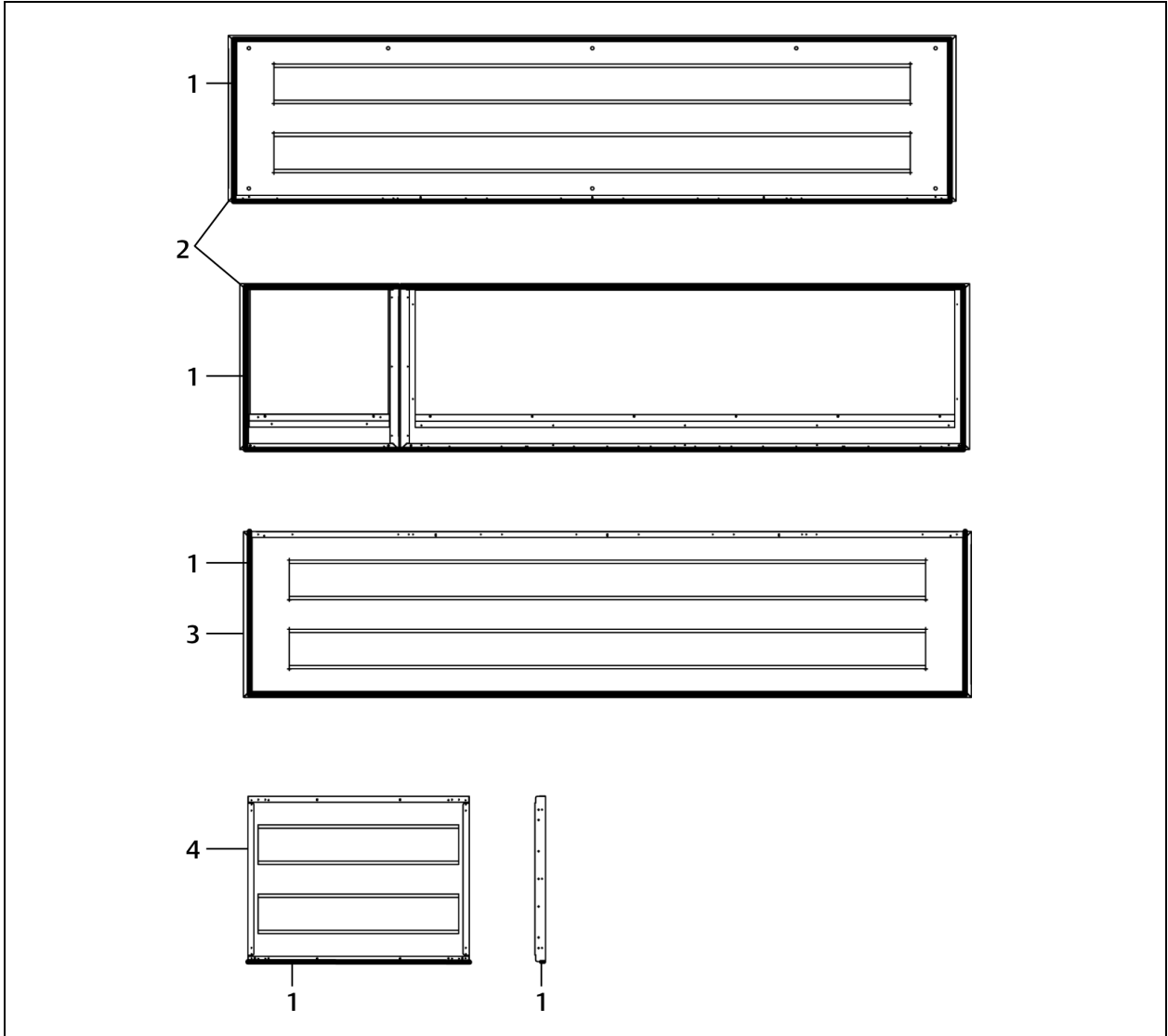

Item	Description
1	Gasketing/Insulation tape
2	Front solid panel, Front and Rear grilled panels
3	Rear solid panel
4	Side panel

2. If assembling a solid rear plenum or a gridded rear plenum shorter than 105 in. (2673 mm), skip to step 3.
 – or –
 If assembling a 105-in. (2676 mm) gridded, rear plenum, attach the long and short panel together using the channel panel and sheet-metal screws as shown in **Figure 7.8** below.

Figure 7.8 105-in. Grilled Rear Panel Assembly

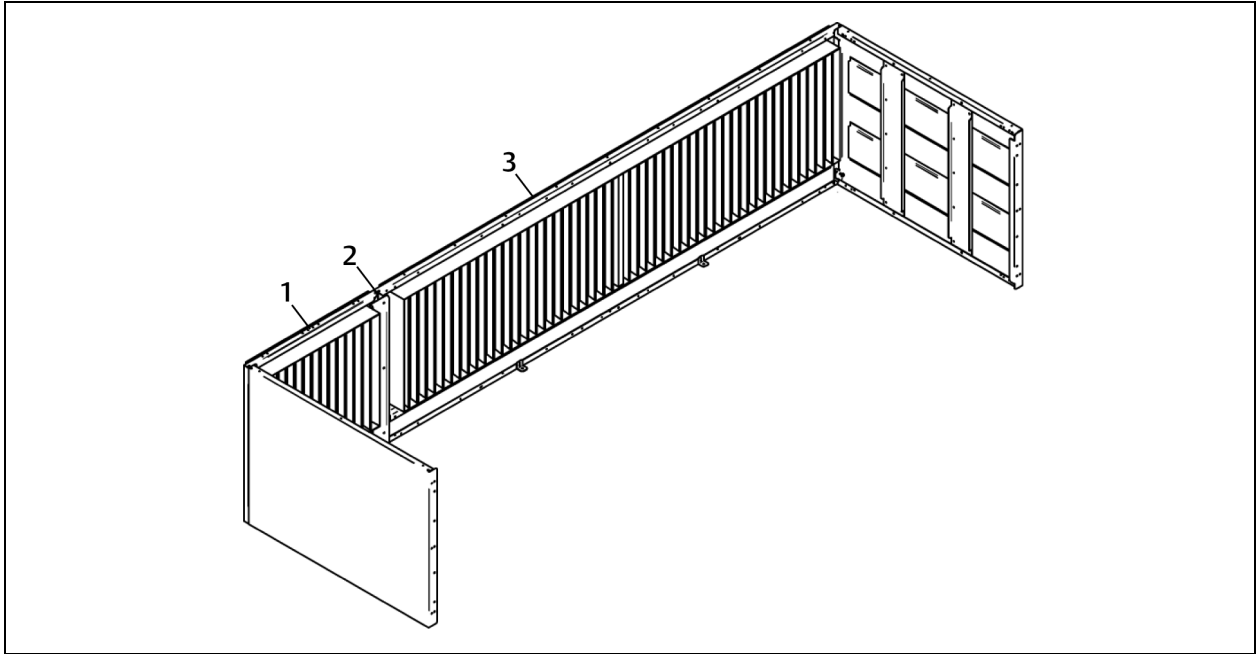

Item	Description
1	Short rear panel
2	Channel panel
3	Long rear panel

3. Attach the 2 side panels to each end of the rear-panel assembly using 10 sheet-metal screws as shown in **Figure 7.9** below .

NOTE: Figure 7.9 below , shows a non-grilled rear plenum as an example. If your unit is rear-discharge, the rear plenum panels have grilles.

Figure 7.9 Attach Side Panels to Rear Panel

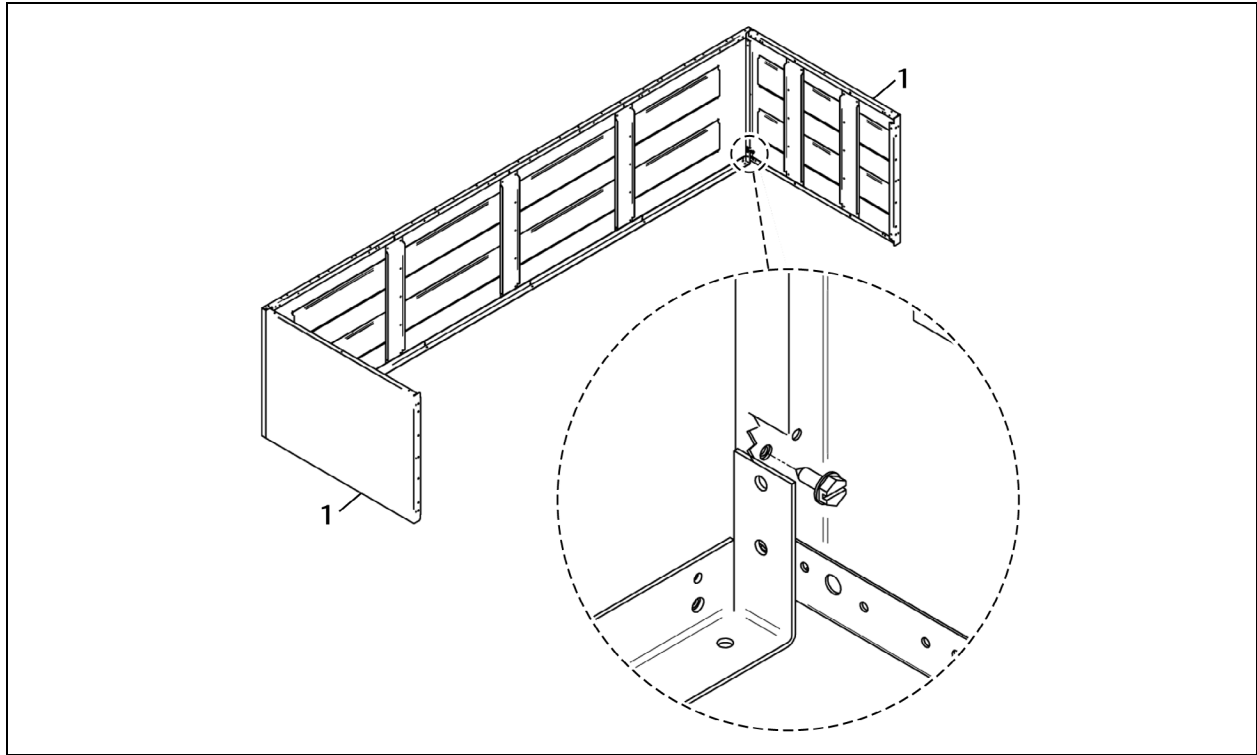

Item	Description
1	Side panel

7.2.3 Place Assembled Panels and EC Fans on Top of Unit

1. Lift the assembled plenum panels and place on top of the unit, **Figure 7.10** below .
2. If assembling a solid rear plenum or a grilled rear plenum shorter than 105 in. (2673 mm), attach the rear-panel assembly using the angle bracket as shown in **Figure 7.10** below .
 - or –
 - If assembling a 105 in. (2676 mm) grilled, attach the rear-panel assembly using two angle brackets and sheet-metal screws as shown in **Figure 7.10** below .

Figure 7.10 Rear Panel Assembly Attached to Top of Unit

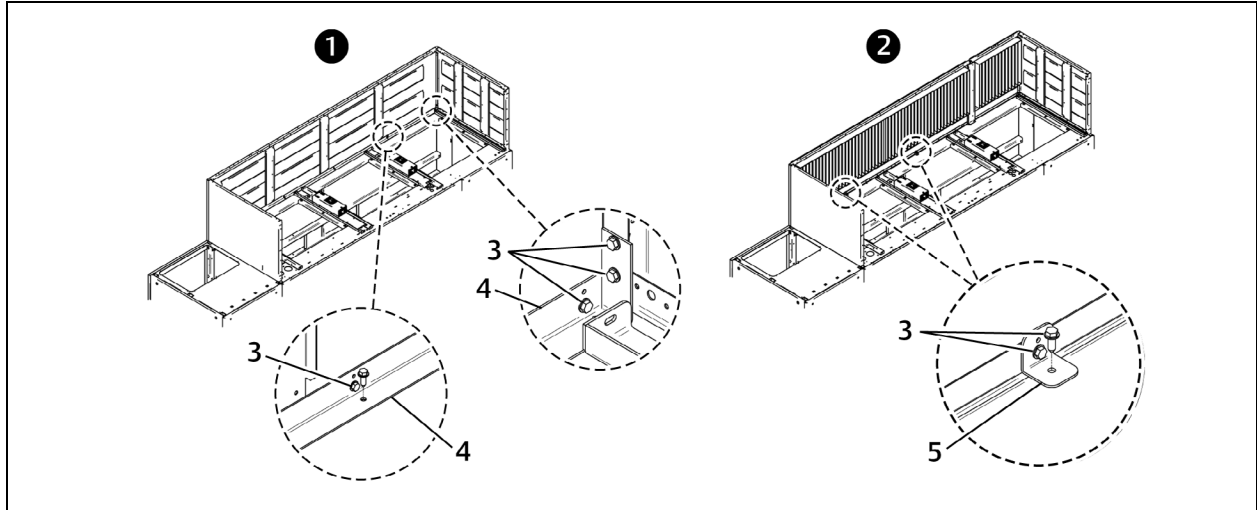

Item	Description
1	Solid rear-panel attachment
2	Grilled rear-panel attachment
3	Sheet-metal screw
4	Angle bracket, 59-in. – 105-in.
5	Angle bracket

3. Refer to **Figure 7.11** below , for the recommended clearance from bottom of the unit to the top of the plenum for access to install the fan(s).
 - Place an EC-fan assembly on the lifting device.
(**Figure 7.11** below , shows a duct lift as one option to lift the EC-fan assembly.)
 - Position the lifting device so that it lines-up with the installation location of the EC-fan assembly.
 - Use the device to lift the EC-fan assembly just above the top of the unit.

Figure 7.11 EC Fan Assembly Positioned for Lifting

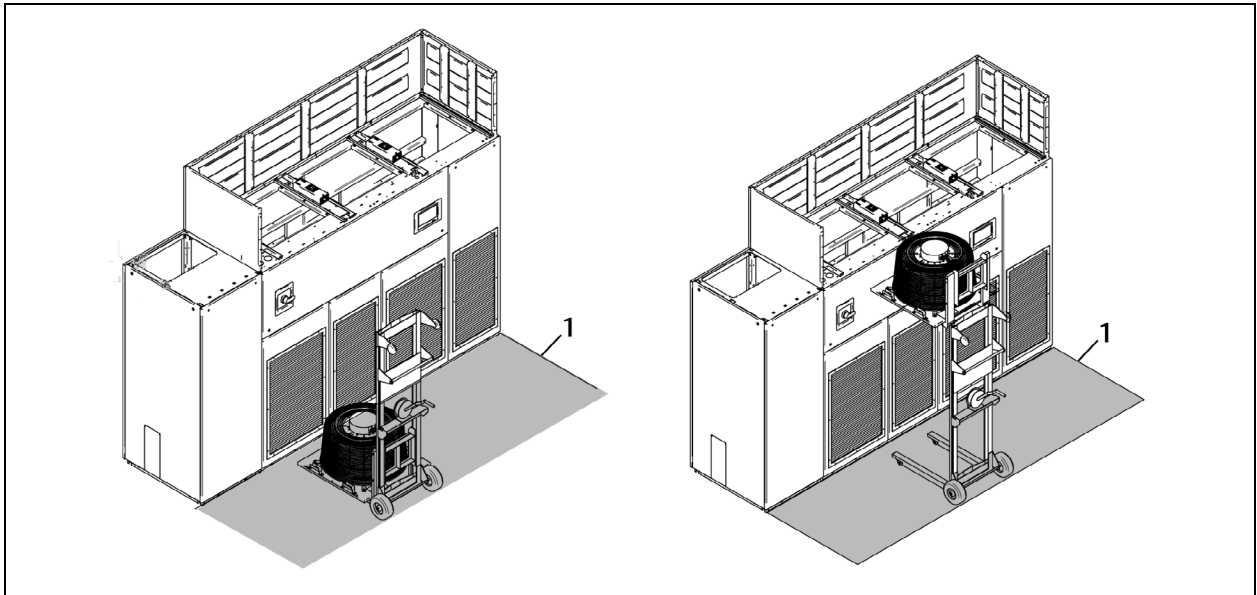

Item	Description
1	Access clearance area of 36 in. (914 mm) from top to bottom of unit

4. Using the handles on the EC-fan assembly, carefully lift the assembly over the hinge along the top of the unit, and slide the assembly onto the top of the unit.
5. Align the mounting holes on the base of the assembly with the threaded holes on top of the unit depending on the size of the unit:
 - For all unit sizes except for 73 in. and 85 in. single-fan units, skip to step 7 .
 - For 73 in. and 85 in. single-fan units, continue with step 6 .

6. Refer to **Figure 7.12** below . The single-fan 73-in. and 85-in. units have 2 sets of mounting holes depending on discharge direction:
- On rear-discharge plenums, align the mounting holes on the EC-fan assembly with threaded holes on the unit labeled 2 in **Figure 7.12** below .
 - On top-discharge and front-discharge plenums, align the mounting holes with the threaded holes on the unit labeled 1 in **Figure 7.12** below .

Figure 7.12 EC Fan mounting Hole Alignment for 73 in. and 85 in. Units

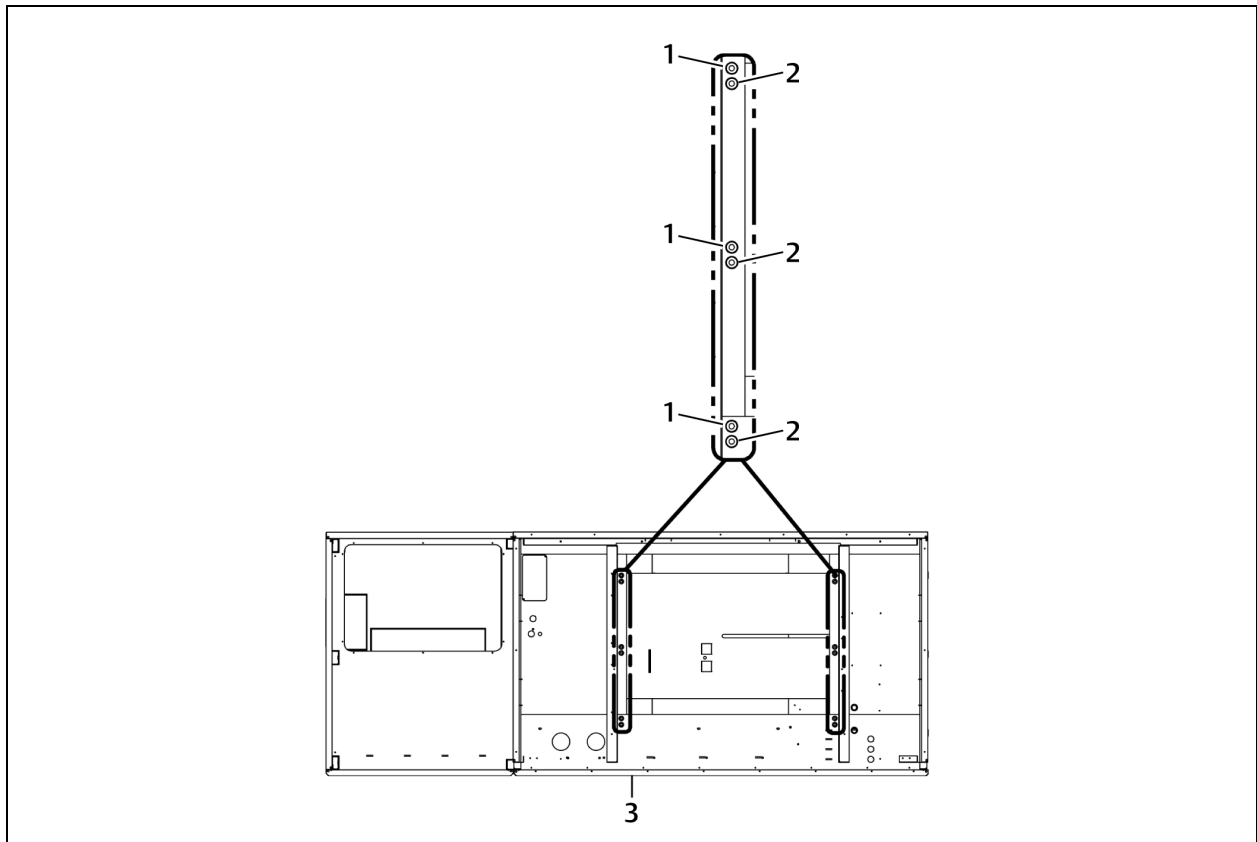

Item	Description
1	Threaded mounting holes for top-discharge and front-discharge plenums.
2	Threaded mounting holes for rear-discharge plenums.
3	Front of the unit.

- Align the mounting holes on the base of the assembly with the threaded holes on top of the unit, **Figure 7.13** below .

Figure 7.13 Assembly in Place on the Unit

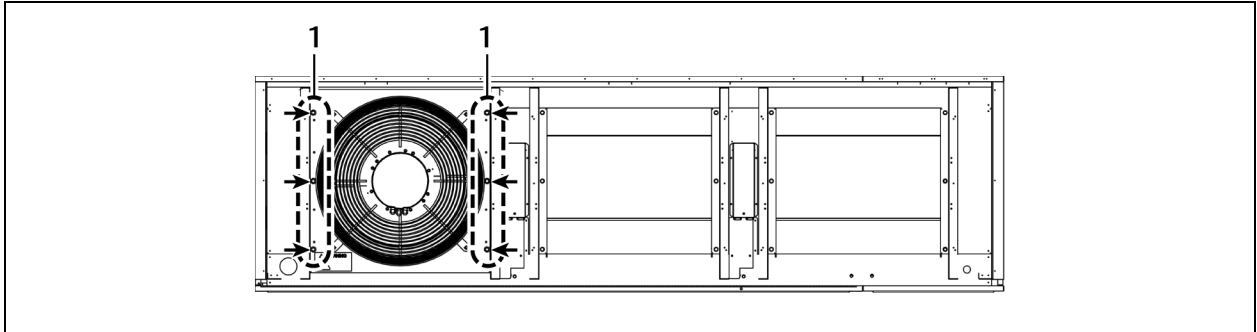

Item	Description
1	Mounting holes

- Use the bolts, washers and spacers, **Figure 7.14** below , to attach the assembly to the unit.
- Repeat steps 3 to 8 for each EC-fan assembly.

Figure 7.14 Attach EC Fan Assembly to Top of Unit (6 Places)

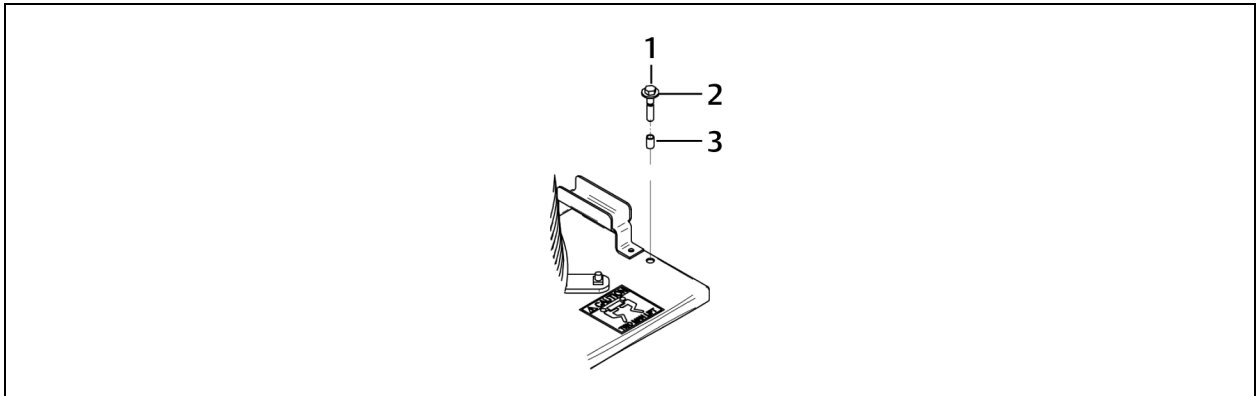

Item	Description
1	Bolt
2	Washer
3	Spacer

7.2.4 Wire the EC Fans



WARNING! Risk of short circuits and electric shock. Can cause serious injury or death. Building and equipment damage can result from cut insulation or damaged wires. Can cause overheated wiring, smoke, fire, activation of fire suppression systems and EMS personnel, and loss of power to fans. Verify that all wiring connections are tight and that all wiring is contained within the junction box prior to closing and securing the cover.

Insert CSA-certified or UL-listed bushings into holes and/or knockouts used to route wiring through metal panels to protect the wire insulation from contact with sheet metal edges.

Black-sleeved harness contains fan-control wires. Grey-sleeved harness contains motor high-volt connection.

1. Refer to **Figure 7.15** below, **Figure 7.16** on the next page, and **Figure 7.17** on page 77, to route the wire harnesses and insert them into the indicated openings on the junction boxes.
 - You may need to remove existing wire ties that hold the harness to the fan cage.

NOTE: Do not route the wiring over the handles on the EC-fan assembly.

2. Connect the wires inside the junction box:
 - Between fan 1 and 2 on 2- and 3-fan units, refer to **Figure 7.16** on the next page.
 - On single-fan or fan 3 of 3-fan units, refer to **Figure 7.17** on page 77.
3. Use provided wire ties to secure the wire harnesses to the fan cage to prevent harness movement when fans are running.

Figure 7.15 EC Fan Junction Boxes

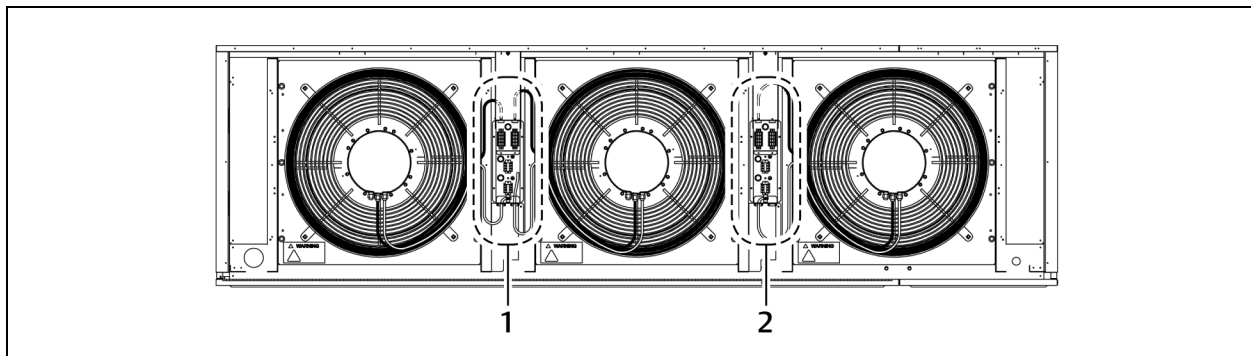

Item	Description
1	Junction box between fans 1 and 2 on 2- and 3-fan unit
2	Junction box for 1- or 3-fan unit

Figure 7.16 Junction Box between Fans 1 and 2

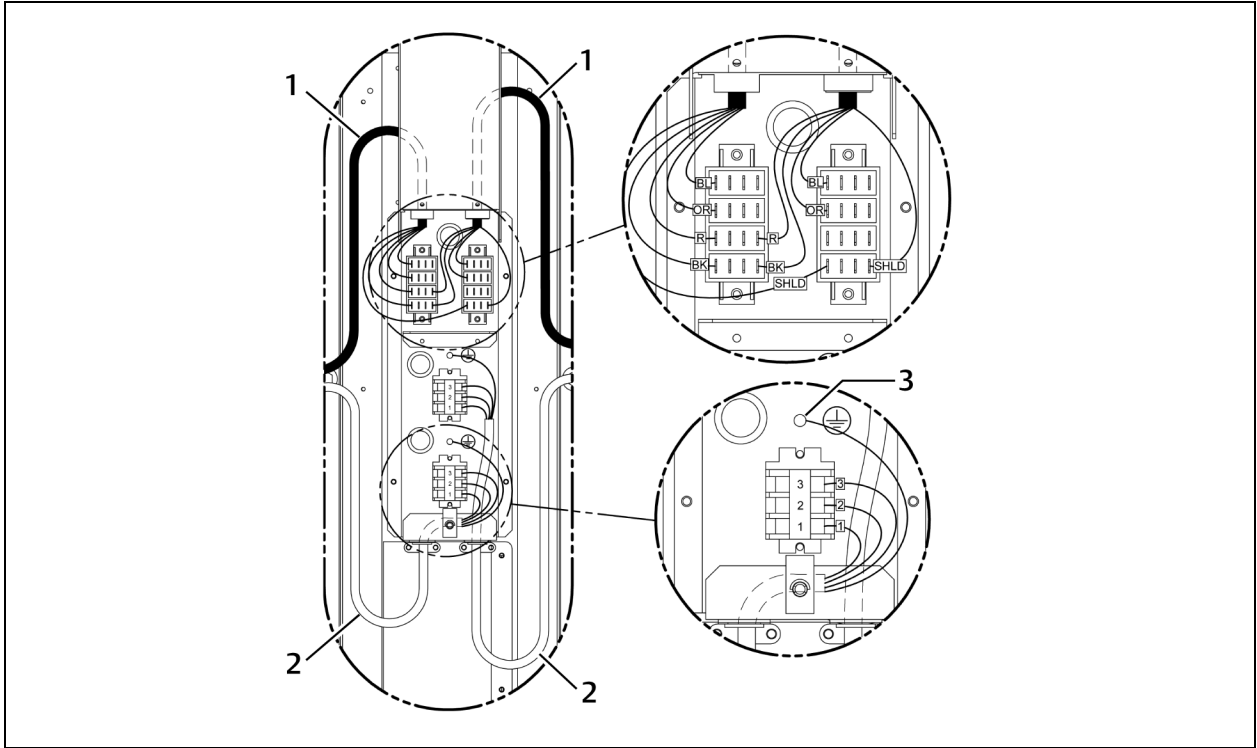

NOTE: For the high-volt terminal blocks, the wire-termination torque is 16-20 in-lbs.

Item	Description
1	Fan (low-volt) wiring
2	Motor (high-volt) wiring
3	Green/Yellow ground wire

Figure 7.17 Junction Box for Single Fan or Fan 3

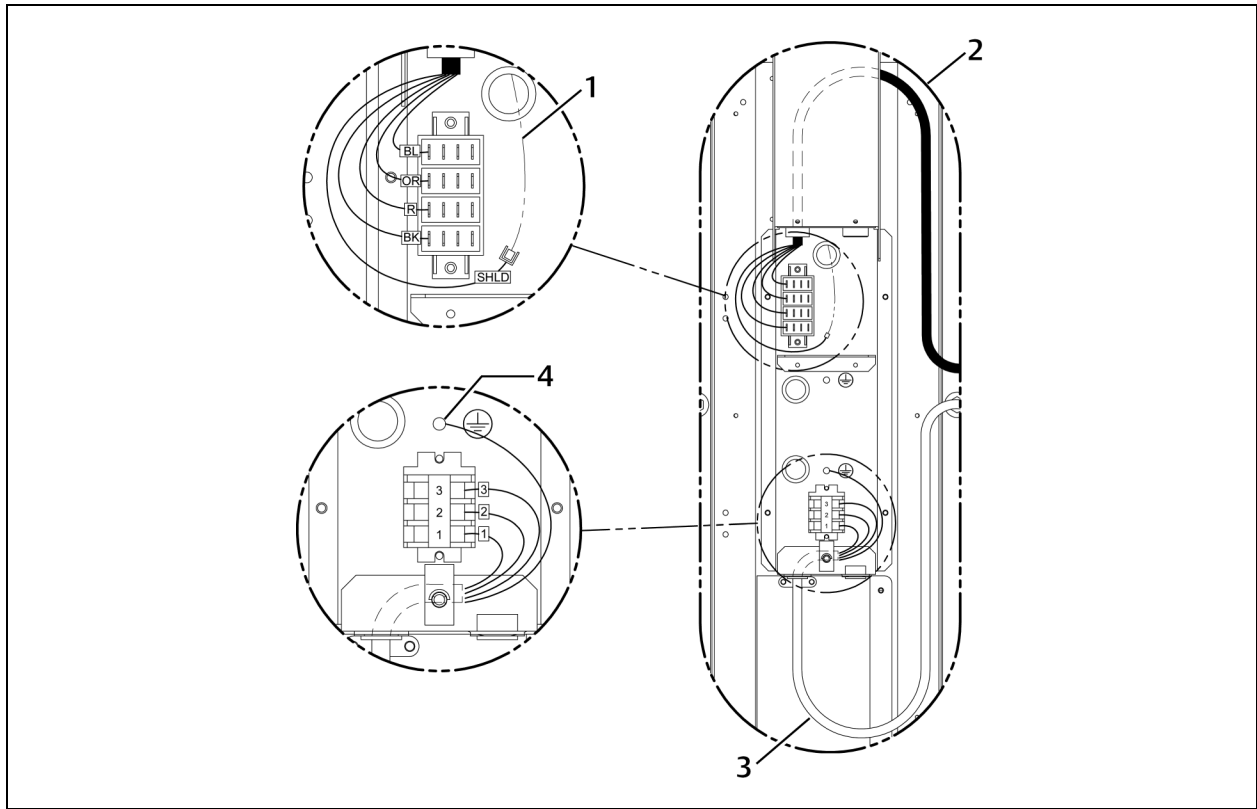

NOTE: For the high-volt terminal blocks, the wire-termination torque is 16-20 in lbs.

Item	Description
1	SHLD wire from unit harness
2	Fan (low-volt) wiring
3	Motor (high-volt) wiring
4	Green/Yellow ground wire

7.2.5 Install Front Panels on Plenum

Non-grilled plenum front panels require assembly and attachment before mounting the panels, see [Non-Grilled and Rear Discharge Front Panel Assembly](#) on the next page.

Grilled plenums do not require a frame assembly, see [Front Discharge Front Panel Assembly](#) on page 85.

Non-Grilled and Rear Discharge Front Panel Assembly

1. Attach the panel-mounting bracket(s), **Figure 7.18** below :
 - Attach the right-side panel-mounting bracket to the top of the unit using 2 bolts and 2 washers and to the side panel using 2 sheet-metal screws as shown in the detail view in **Figure 7.18** below .
 - If a second panel-mounting bracket is included, attach in the center location using 2 bolts and 2 washers.

Figure 7.18 Panel Mounting Bracket Attachment

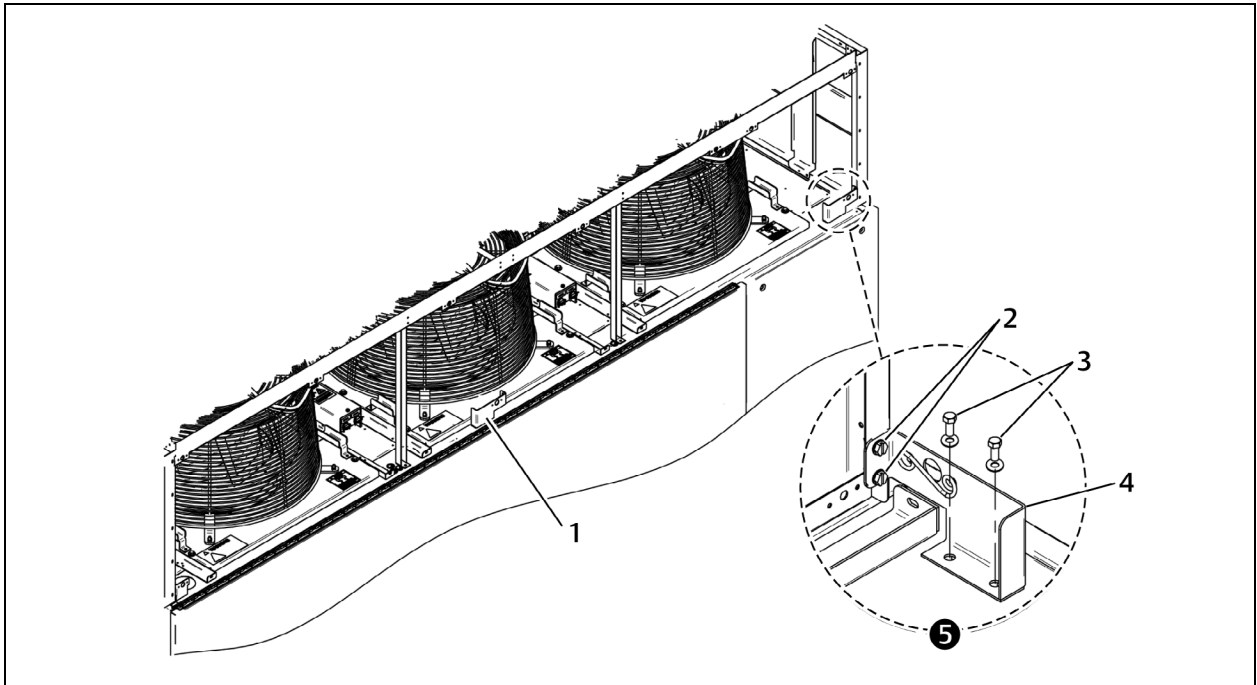

Item	Description
1	Panel mounting bracket
2	Sheet-metal screws
3	Bolt and Washer
4	Panel mounting bracket
5	Detail view of right-side bracket installation. Shown from inside the plenum.

2. Attach the channel frame(s) to the top frame using 3 sheet-metal screws:
 - For non-grilled plenums, make sure the dimple shown in **Figure 7.19** below, is on the bottom flange of the top frame.
 - For rear-discharge plenums, make sure the dimple shown in **Figure 7.19** below, is on the top flange of the top frame.

NOTE: The number of channel frames varies depending on the size of plenum.

Figure 7.19 Channel Frame Top Attachment

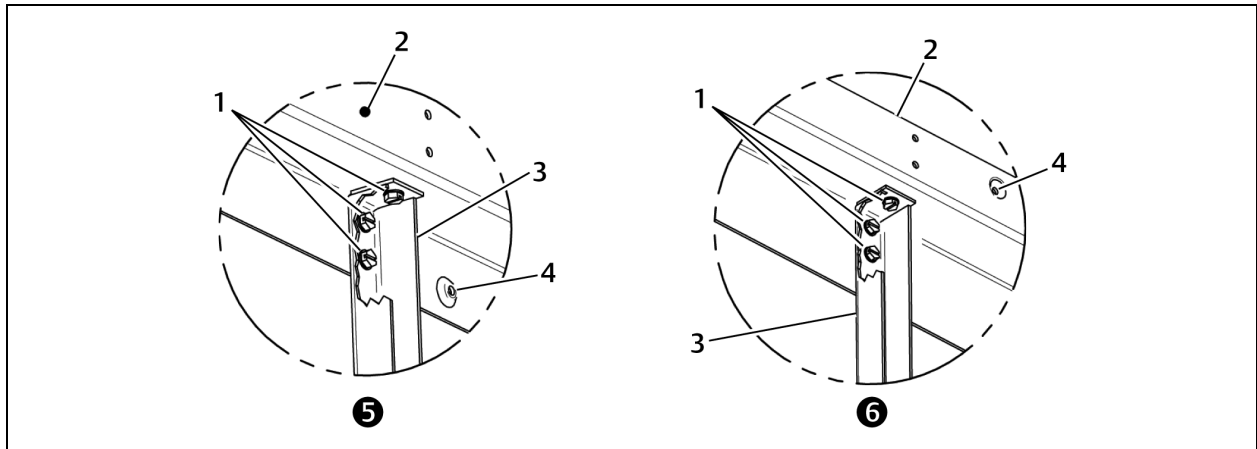

Item	Description
1	Sheet-metal screws
2	Top frame
3	Channel frame
4	Dimple
5	Attachment on non-grilled plenum. Shown from bottom.
6	Attachment on rear-discharge plenum. Shown from bottom.

3. Attach the assembled top/channel frame to the side panels on top of the unit:
 - For non-grilled plenums, refer to **Figure 7.20** below . and use 2 sheet-metal screws on each end.
 - For rear-discharge, refer to **Figure 7.20** below , and attach the smaller flange to the side panel using 2 sheet-metal screws on each end.

Figure 7.20 Top Frame Attachment to Sides

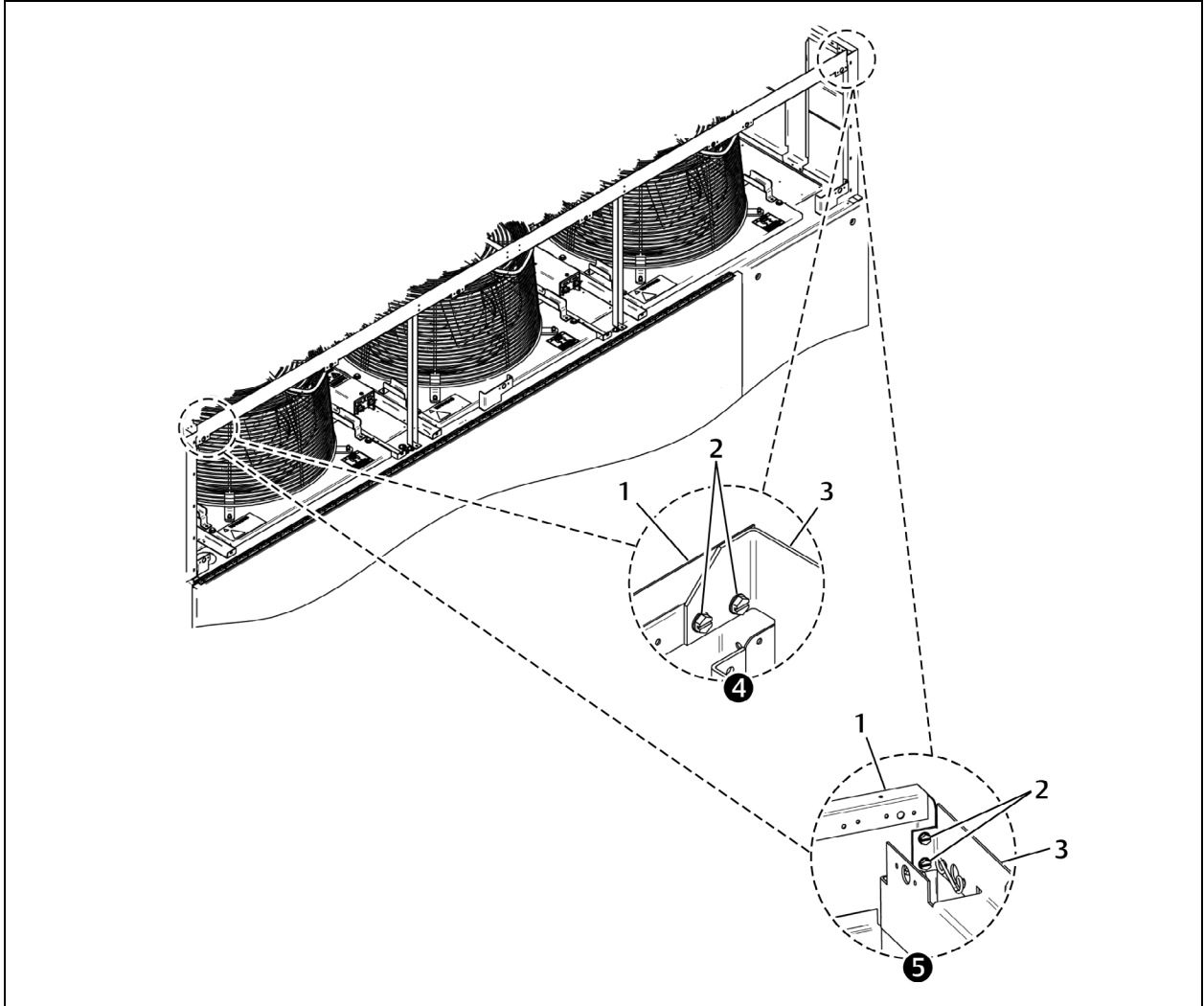

Item	Description
1	Side panel
2	Sheet-metal screws
3	Top frame
4	Attachment for non-grilled plenums. Shown from inside the plenum.
5	Attachment for rear-discharge plenum. Shown from inside the plenum.

4. Attach the bottom of the channel frame(s) to the top of the unit using 1 washer and 1 bolt for each, **Figure 7.21** below .

Figure 7.21 Channel Frame Bottom Attachment

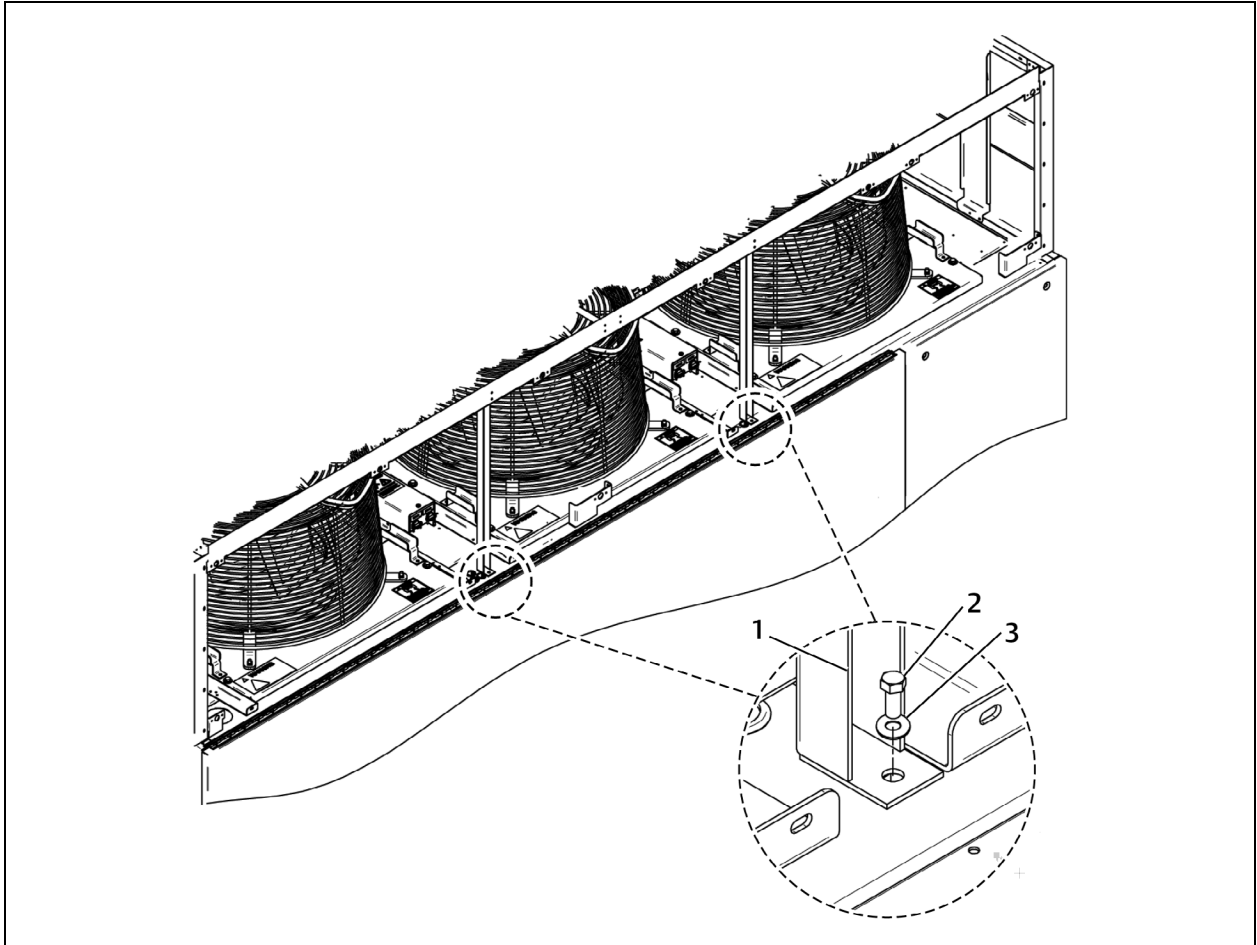

Item	Description
1	Channel frame
2	Bolt
3	Washer

5. For non-grilled plenums, refer to **Figure 7.22** below, and attach the plenum brace to the top frame and the rear panel using 2 sheet-metal screws on each end.

Figure 7.22 Non-Grilled Plenum Plenum-Brace Attachment

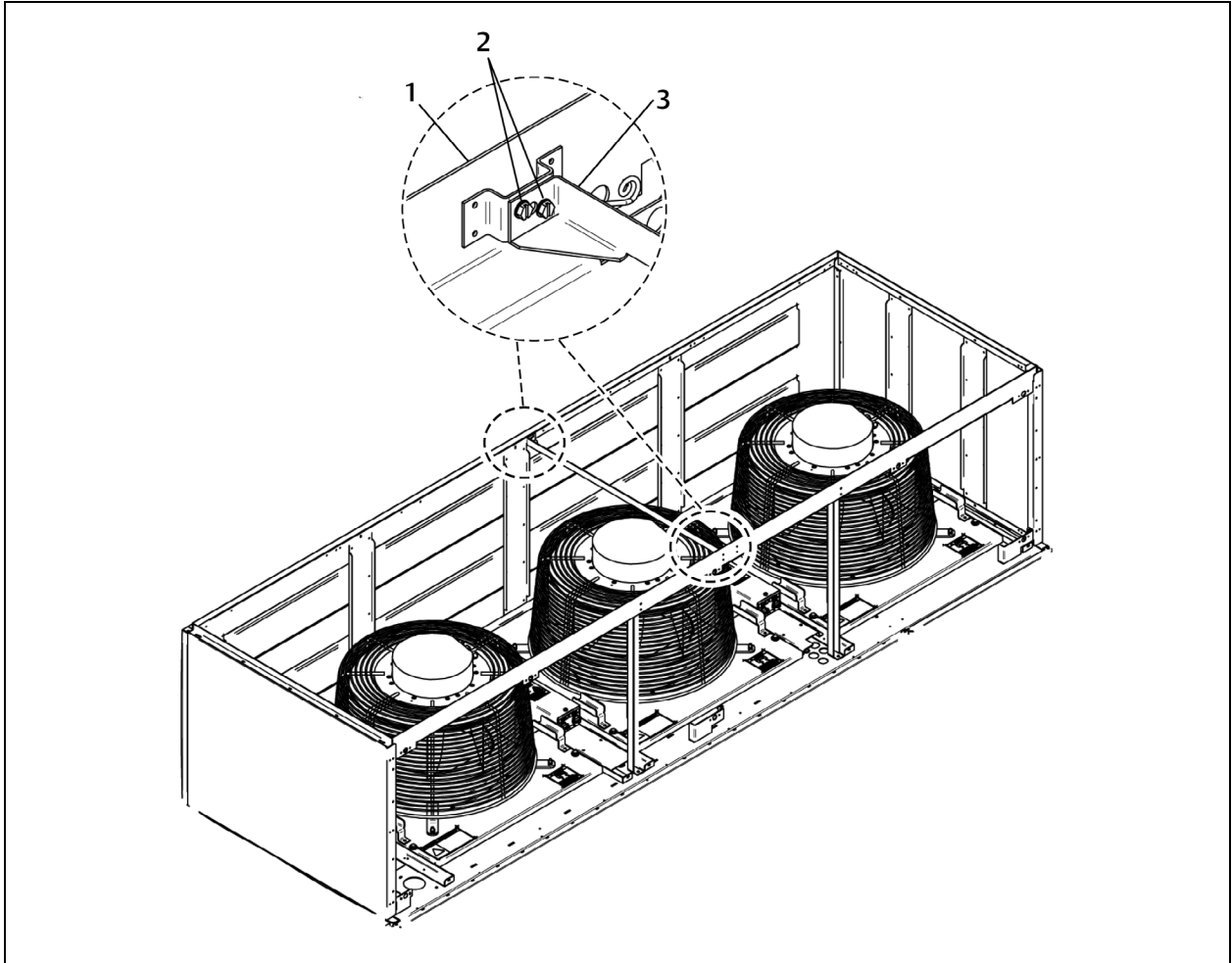

Item	Description
1	Top frame on front of plenum. Shown from inside.
2	Sheet-metal screws
3	Plenum brace

6. For non-grilled plenums, skip to step 7.

– or –

For rear-discharge plenums, assemble and attach the top panels:

- If a top-panel brace and plain top panel is included, attach them to the top panel with holes using 3 sheet-metal screws as shown in **Figure 7.23** below .
- Attach the top panel to the side and rear panels using 18 sheet-metal screws, **Figure 7.23** below .
- Attach the top panel to the top frame using 6 sheet-metal screws, **Figure 7.23** below .

Figure 7.23 Rear Discharge Top Panel Assembly and Attachment

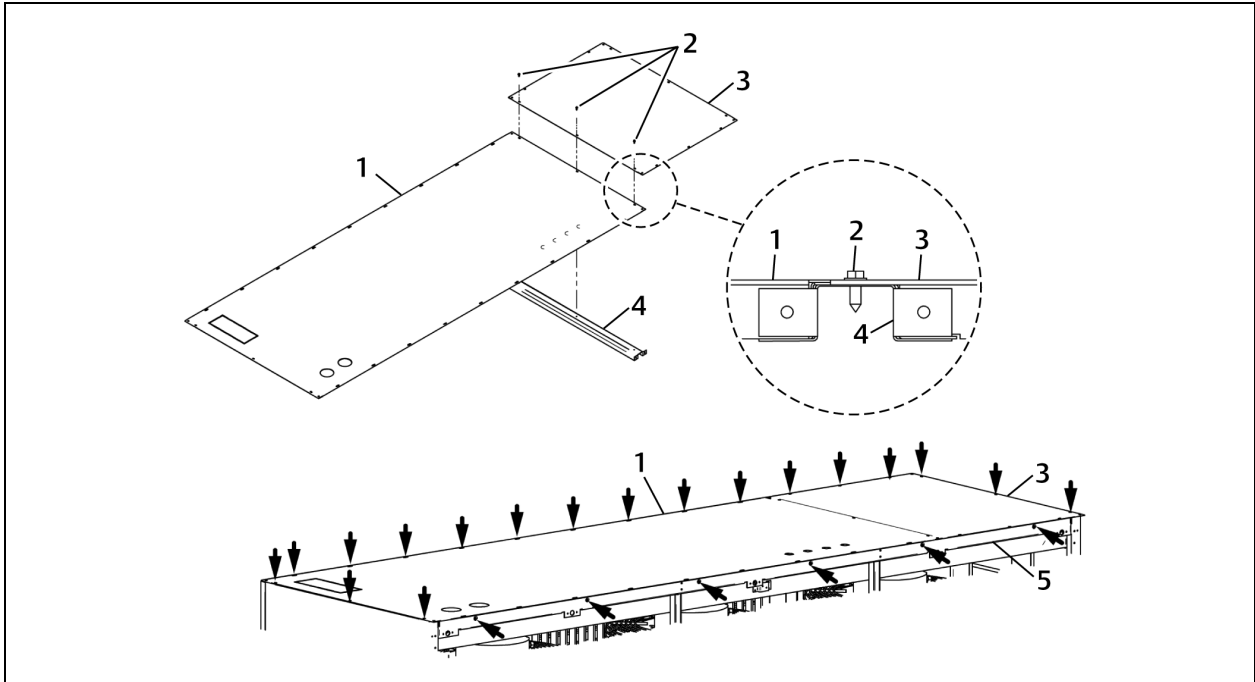

Item	Description
1	Top panel (with holes)
2	Sheet-metal screws
3	Top panel (plain)
4	Top-panel brace
5	Top frame

7. Attach the solid front panel using the quarter-turn fasteners in the panels, **Figure 7.24** below .

Figure 7.24 Front Panel Attachment

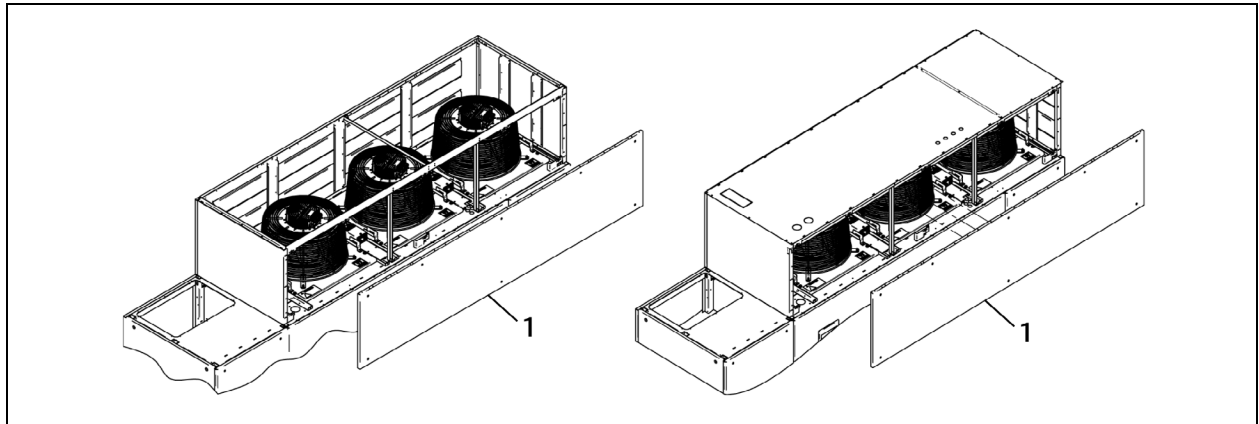

Item	Description
1	Front panel

Front Discharge Front Panel Assembly

1. Using the channel panel and 10 sheet-metal screws, attach the grilled front panel and the short, grilled front panel, **Figure 7.25** below .
2. Attach the assembled front panels to the plenum sides using 10 sheet-metal screws, 5 on each end.

Figure 7.25 Front Discharge Front Panel Attachment

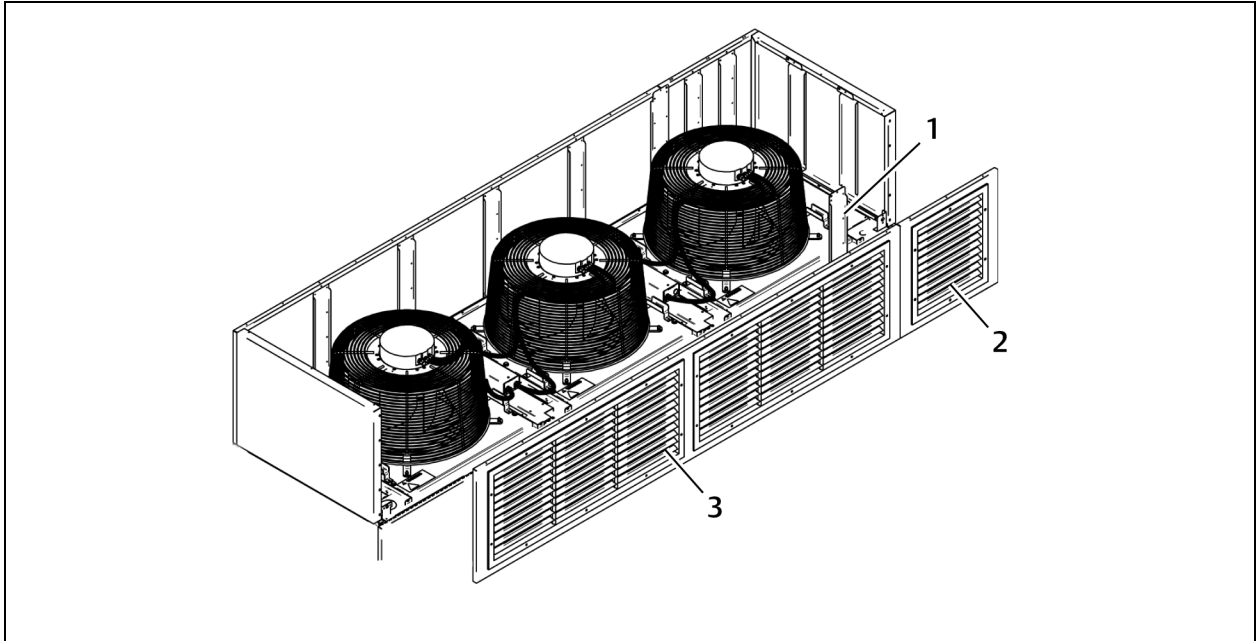

Item	Description
1	Channel panel
2	Short front panel
3	Front panel

3. Assemble and attach the top panels:
 - If a top-panel brace and plain top panel is included, attach them to the top panel with holes using 3 sheet-metal screws as shown in **Figure 7.25** on the previous page .
 - Attach the top panel and to top of the plenum assembly using 39 sheet-metal screws, **Figure 7.26** below .

Figure 7.26 Front Discharge Top Panel Assembly and Attachment

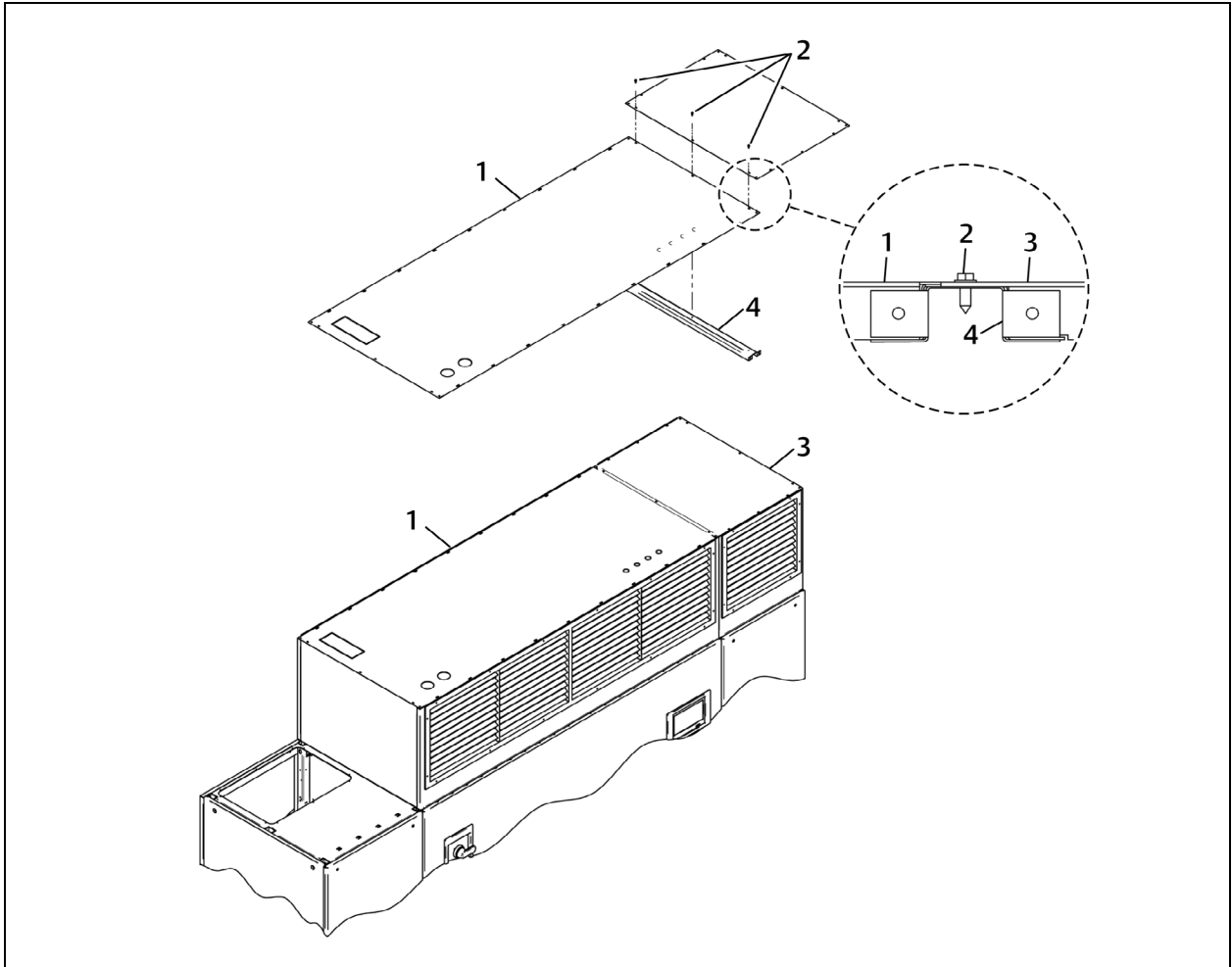

Item	Description
1	Top panel (with holes)
2	Sheet-metal screws
3	Top panel (plain)
4	Top-panel brace

8 Checklist for Completed Installation

8.1 Moving and Placing Equipment

1. Unpack and check received material.
2. Proper clearance for service access has been maintained around the equipment.
3. Equipment is level and mounting fasteners are tight.
4. If equipment has been disassembled for installation, unit must be reassembled per instructions.

8.2 Electrical Installation Checks

1. Supply voltage and phase matches equipment nameplate.
2. Power wiring connections completed to the disconnect switch, evaporator unit and heat rejection equipment.
3. Power line circuit breakers or fuses have proper ratings for equipment installed.
4. Control wiring connections completed between indoor evaporator and heat-rejection equipment.
5. All internal and external high- and low-voltage wiring connections are tight.
6. Confirm that unit is properly grounded to an earth ground.
7. Control transformer setting matches incoming power.
8. Electrical service conforms to national and local codes.
9. Check blowers and compressors for proper rotation.
10. For upflow units only: Field installed low-voltage wiring routed with loop to allow electric box to swing.

8.3 Piping Installation Checks

1. Piping completed to refrigerant or coolant loop (if required).
2. Piping has been leak-checked, evacuated and charged (if required).
3. Additional oil has been added for system charges over 40 pounds (18.1kg) per circuit. See [Additional Oil Requirements for Scroll and Digital Scroll Compressors](#) on page 41.
4. Piping is properly sized, sloped and trapped as shown in the piping schematics.
5. Check piping inside and outside of equipment for proper support and adequate spacing to prevent rub-through.
6. Ensure that factory clamps have been reinstalled.
7. Drain line connected, not obstructed, and pitched per local code.
8. Water supply line connected to humidifier and not leaking.
9. Condensate drain line piping has no leaks or visible damage.

8.4 Other Installation Checks

1. Ducting or plenum assembly complete (if required), maintain access to filters.
2. Filters installed.
3. Check fasteners that secure , reheats, humidifier and motors—some may have become loose during shipment.
4. Verify water detection is properly installed around all units (recommended).
5. Humidifier control panel DIP switches are set based on user requirements.

6. Compressor shipping blocks removed and springs adjusted (see [Remove Shipping Blocks from Units with Semi-Hermetic Compressors](#) on page 29).
7. Blower drive system rotates freely and belts are properly aligned and tensioned.
8. All fans are free of debris.
9. Remove rubber band from float in optional infrared humidifier.
10. Seal openings around piping and electrical connections.
11. Installation materials and tools have been removed from equipment (literature, shipping materials, construction materials, tools, etc.).
12. Review and complete installation checklists for heat-rejection units (condensers/drycoolers), if included.
13. Locate blank start-up sheet, ready for completion by installer or start-up technician.

9 Initial Start-up Checks and Commissioning Procedure for Warranty Inspection



WARNING! Arc flash and electric shock hazard. Can cause serious injury or death. Building and equipment damage may also result. Disconnect all local and remote electric power supplies and wear appropriate, OSHA-approved personal protective equipment (PPE) per NFPA 70E before working within the electric control enclosure. Customer must provide earth ground to unit, per NEC, CEC and local codes, as applicable.

Verify with a voltmeter that power is Off. The Vertiv™ Liebert® iCOM™ controller does not isolate power from the unit, even in the “Unit Off” mode. Some internal components still require and receive power even during the “Unit Off” mode of the Liebert® iCOM™ controller. The factory-supplied, optional disconnect switch is inside the unit. The line side of this switch contains live high voltage. The only way to ensure that there is NO voltage inside the unit is to install and open a remote disconnect switch. Refer to unit electrical schematic.

Before proceeding with installation, read all instructions, verify that all the parts are included and check the nameplate to be sure the voltage matches available utility power. Follow all local codes.



WARNING! Risk of electric shock. Can cause serious injury or death. Building and equipment damage may also result. Open all local and remote electric power supply disconnect switches and verify that power is off with a voltmeter before working within any electric connection enclosures. The Liebert® iCOM™ controller does not isolate power from the unit, even in the "Unit Off" mode. Some internal components require and receive power even during the "unit off" mode of the Liebert® iCOM™ controller .

Installation, service, and maintenance work must be performed only by properly trained and qualified personnel and in accordance with applicable regulations and manufacturers' specifications. Opening or removing the covers to any equipment may expose personnel to lethal voltages within the unit even when it is apparently not operating and the input wiring is disconnected from the electrical source.



WARNING! Risk of improper wiring, piping, moving, lifting, and handling. Can cause serious injury or death. Building and equipment damage may also result. Installation and service of this equipment should be done only by qualified personnel who have been specially-trained in the installation of air-conditioning equipment and who are wearing appropriate, OSHA-approved PPE.



CAUTION: Risk of smoke generation. Can cause injury. Can cause fire suppression and alarm system activation, resulting in building evacuation and mobilization of emergency fire and rescue services. Start-up operation of optional electric reheat elements can create smoke or fumes that can activate the facility alarm and fire suppression system. Prepare and take appropriate steps to manage this possibility. Activating reheat during initial start-up may burn off particulates from electric reheat elements. Before beginning initial start-up checks, make certain that unit was installed according to the instructions in this manual. All exterior panels must be in place.

NOTICE

Risk of improper electrical connection of three-phase input power. Can cause backward compressor rotation and unit damage. Service technicians should use a gauge set on the system during the initial start up to verify that the three-phase power is connected properly. The EC fans are not a reliable indicator of proper connection. The blowers will rotate the same direction, regardless of the three-phase power input. Three-phase power must be connected to the unit line voltage terminals in the proper sequence so that the compressors rotate in the proper direction. Incoming power must be properly phased to prevent compressors from running backward. We recommend checking the unit's phasing with proper instrumentation to ensure that power connections were made correctly. We also recommend verifying discharge and suction pressures during start up to ensure that the compressors are running in the correct direction.

- Confirm that all items on [Checklist for Completed Installation](#) on page 87 have been done.
- Locate "Vertiv™ Liebert® DS Warranty Inspection Check Sheet" in the unit's electric panel. (PSWI-8542-405-CO).
- Complete "Liebert® DS Warranty Inspection Check Sheet" during start-up. (PSWI-8542-405-CO).
- Forward the completed "Liebert® DS Warranty Inspection Check Sheet" to your local sales office. **This information must be completed and forwarded to validate warranty.**
- Contact your local sales representative or technical support if you have any questions or problems during unit start-up and commissioning. Visit <https://www.Vertiv.com/en-us/support/> or call 1-800-543-2778 for contacts.

10 Maintenance



WARNING! Arc flash and electric shock hazard. Can cause serious injury or death. Building and equipment damage may also result. Disconnect all local and remote electric power supplies and wear appropriate, OSHA-approved personal protective equipment (PPE) per NFPA 70E before working within the electric control enclosure. Customer must provide earth ground to unit, per NEC, CEC and local codes, as applicable.

Verify with a voltmeter that power is Off. The Vertiv™ Liebert® iCOM™ controller does not isolate power from the unit, even in the “Unit Off” mode. Some internal components still require and receive power even during the “Unit Off” mode of the Liebert® iCOM™ controller. The factory-supplied, optional disconnect switch is inside the unit. The line side of this switch contains live high voltage. The only way to ensure that there is NO voltage inside the unit is to install and open a remote disconnect switch. Refer to unit electrical schematic.

Before proceeding with installation, read all instructions, verify that all the parts are included and check the nameplate to be sure the voltage matches available utility power. Follow all local codes.



WARNING! Risk of electric shock. Can cause serious injury or death. Building and equipment damage may also result. Open all local and remote electric power supply disconnect switches and verify that power is off with a voltmeter before working within any electric connection enclosures. The Liebert® iCOM™ controller does not isolate power from the unit, even in the "Unit Off" mode. Some internal components require and receive power even during the "unit off" mode of the Liebert® iCOM™ controller .

Installation, service, and maintenance work must be performed only by properly trained and qualified personnel and in accordance with applicable regulations and manufacturers' specifications. Opening or removing the covers to any equipment may expose personnel to lethal voltages within the unit even when it is apparently not operating and the input wiring is disconnected from the electrical source.



WARNING! Risk of improper wiring, piping, moving, lifting and handling. Can cause serious injury or death. Building and equipment damage may also result. Installation and service of this equipment should be done only by qualified personnel who have been specially-trained in the installation of air-conditioning equipment and who are wearing appropriate, OSHA-approved PPE.

The Vertiv™ Liebert® DS is a single component in the facility heat-removal system. The system includes air distribution (raised floors, duct systems), outdoor heat rejection (condensers, pumps, drycoolers) and indoor cooling and humidity loads (equipment load, location, outside air infiltration). Proper application and maintenance of the entire system is critical to the life and reliability of the thermal-management units.

- Good maintenance practices are essential to minimizing operation costs and maximizing product life.
- Read and follow monthly and semi-annual maintenance schedules included in this manual. These MINIMUM maintenance intervals may need to be more frequent based on site-specific conditions.
- See the Vertiv™ Liebert® iCOM™ user manual, SL-31075, available at www.Vertiv.com, for instructions on using the controller to predict some service maintenance intervals.
- We recommend the use of trained and authorized service personnel, extended service contracts and factory-specified replacement parts. Contact your Vertiv sales representative.

10.1 Filters

NOTICE

Risk of improper filter installation. Can cause filter collapse and airflow reduction.

Pleat direction is non-standard. Use only short-pleat filters (see **Figure 10.2** on page 94). Long-pleat filters are subject to collapse at high airflows.

To maximize the performance and reliability of the equipment, use only Vertiv filters. Contact your Vertiv representative to order replacement filters.

Verify that filters are installed and positioned so the air-flow direction marked on the filter is the same direction as unit air flow.

Table 10.1 Filter Quantities

	035	042	053	070	077	105
Downflow Models						
Quantity	3	3	4	4	4	4
Nominal Size, inches	2 @ 25x20	2 @ 25x20	4 @ 25x20	4 @ 25x20	4 @ 25x20	2 @ 25x20
	1 @ 25x16	1 @ 25x16				4 @ 25x16
Upflow Models (Front & Rear return) Filters located in separate filter box on rear return, located on lower unit panel						
Quantity	4	4	6	6	6	8
Nominal Size, inches	25x20	25x20	25x20	25x20	25x20	25x20
Disposable Type - Nominal Sizes and Quantities, Standard MERV 8 or Optional MERV 11; (filter types cannot be mixed, must be all MERV 8 or all MERV 11)						

10.1.1 Filter Replacement for Downflow Units

1. Disconnect power from the unit.
2. Open the front access panel, locate the filter above the electric panel, and slide the filter out the front of the unit.
3. Replace with new filter—install the filter in the proper direction of the airflow.
4. Test the operation of the filter clog switch.
The unit panels must be in place and closed to find this point.

5. Start the blower and turn the switch counterclockwise until the alarm is energized.
6. Turn the adjusting knob one turn clockwise or to the desired filter change point.

Figure 10.1 Proper Filter Pleat Direction

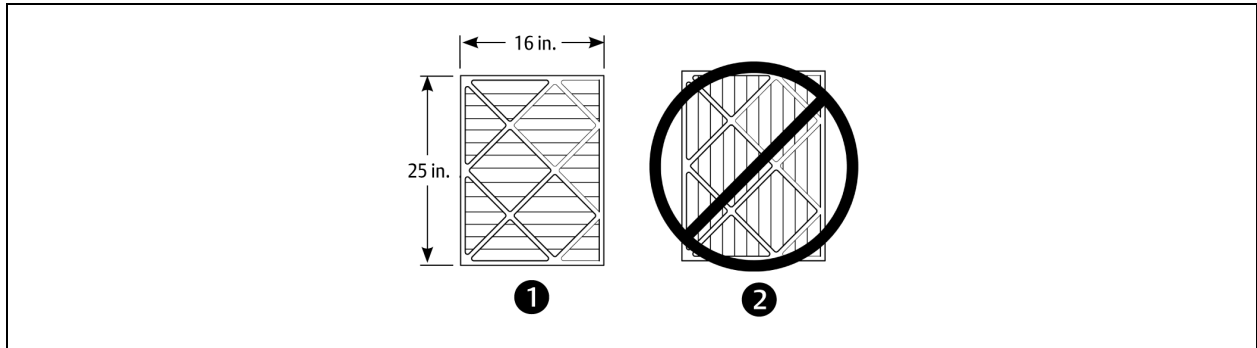

Item	Description
1	Short pleat construction
2	Long pleat construction

10.1.2 Filter Replacement for Upflow Units

1. Disconnect power from the unit.
2. Open the front access panel and remove the filter(s).
 - For upflow front return units, remove the lower front access panels, lift filters to the top of the filter rack and tilt forward for removal.
 - For upflow rear return units, remove filters using filter access door in rear return filter box.
3. Replace with new filter—install the filters in the proper direction of the airflow. The proper direction is marked on the filter.
4. Test the operation of the filter clog switch.
The unit panels must be in place and closed to find this point.

5. Start the blower and turn the switch counterclockwise until the alarm is energized.
6. Turn the adjusting knob one turn clockwise or to the desired filter change point.

Figure 10.2 Proper Filter Pleat Direction

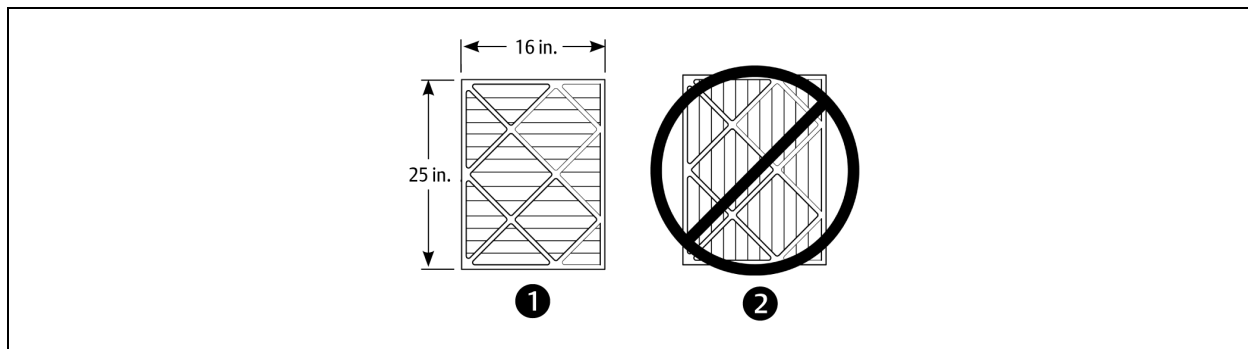

Item	Description
1	Short pleat construction
2	Long pleat construction

10.2 Blower Drive System—EC Fans



WARNING! Risk of electric shock. Can cause serious injury or death. Open all local and remote electric power supply disconnect switches and verify with a voltmeter that power is off before working within the fan-motor electric-connection enclosures. Fan-motor controls can maintain an electric charge for 10 minutes after power is disconnected. Wait 10 minutes after power is verified as off before working within the electric control/connection enclosures. Use only fully-trained and qualified HVAC technicians to perform maintenance on the fans.



WARNING! Risk of contact with high-speed rotating fan blades. Can cause serious injury or death. Open all local and remote electric power-supply disconnect switches, verify with a voltmeter that power is off, and verify that all fan blades have stopped rotating before working in the unit cabinet or on the fan assembly. If control voltage is applied, the fan motor can restart without warning after a power failure. Do not operate the unit with any or all cabinet panels removed. Do not operate upflow units without installing a plenum, ductwork or guard over the blower opening(s) on the top surface of the unit cabinet. Ductwork must be connected to the blower(s) or a plenum must be installed on the blower deck for protection from rotating blower wheel(s) on upflow units.



WARNING! Risk of extremely heavy fan modules dropping downward suddenly. Can cause serious injury or death. Building and equipment damage may also result. Fan modules weigh in excess of 125-lb (56.7-kg) each. Support fan modules before removing mounting hardware. Use caution to keep all body parts out of the fan module pathway of movement during removal or repositioning. Only properly trained and qualified personnel should work on this equipment.

More than one person may be required to complete the assembly and installation. Installer(s) must be properly trained and qualified to lift, move and manipulate very heavy equipment from floor level to the top of the unit. Wear appropriate, OSHA-approved PPE when moving, lifting, installing, and removing the fan(s) and plenum. Read and follow the lifting equipment and/or ladder manufacturer's operating instructions and safety requirements.



WARNING! Risk of contact with sharp edges, exposed fasteners, and improper handling of very heavy parts. Can cause serious injury or death. Building and equipment damage may also result. Use extreme caution, wear appropriate, OSHA-approved PPE, and install the EC fan(s) and plenum to the unit only as described in these instructions.

More than one person may be required to complete the assembly and installation. Installer(s) must be properly trained and qualified to lift, move and manipulate very heavy equipment from floor level to the top of the unit.

Wear appropriate, OSHA-approved PPE when moving, lifting and installing the fan(s) and plenum.

Equipment used in moving, lifting and installing the fan(s) and plenum must meet OSHA requirements and be rated for the weight of the fan(s) and the plenum. If ladders are used, verify that they are rated for the combined weight of the fan(s), plenum and installer(s) as loaded. EC Fan and plenum weights are specified in **Table 7.1** on page 61 and **Table 7.2** on page 62 .

Read and follow the lifting equipment and/or ladder manufacturer's operating instructions and safety requirements.



WARNING! Risk of improper drive-belt removal. Can cause serious injury or death. If improperly handled, the spring-loaded motor base can slam down suddenly causing serious injury to hands and fingers from crushing and pinching. Read the directions in this manual and on the unit instruction labels. Keep hands and fingers away from pinch points. Wear appropriate, OSHA-approved PPE when performing maintenance on the belts, motors or pulleys. Follow all directions when servicing the unit.



CAUTION: Risk of improper moving, lifting and handling. Can cause injury. Building and equipment damage may also result. Only properly trained and qualified personnel should work on this equipment. Evaporator fan modules weigh in excess of 125-lb (56.7-kg). Use proper lifting techniques and wear appropriate OSHA-approved PPE to avoid injury and dropping the fan module during removal. Equipment used in handling/lifting, and/or installing the fan assembly must meet OSHA requirements. Use handling/lifting equipment rated for the weight of the fan assembly. Use ladders rated for the weight of the fan assembly and technicians if used during installation. Refer to handling/lifting, and/or installation equipment operating manual for manufacturer's safety requirements and operating procedures.

NOTICE

Risk of improper power-supply connection. Can cause equipment damage and loss of warranty coverage.

Prior to connecting any equipment to a main or alternate power source (for example: back-up generator systems) for start-up, commissioning, testing, or normal operation, ensure that these sources are correctly adjusted to the nameplate voltage and frequency of all equipment to be connected. In general, power-source voltages should be stabilized and regulated to within $\pm 10\%$ of the load nameplate nominal voltage. Also, ensure that no three-phase sources are single-phased at any time. See transformer label for primary tap connections. Installer will need to change transformer primary taps if applied unit voltage is other than pre-wired tap voltage.

NOTICE

Risk of improper installation. Can cause equipment damage.

Only a properly trained and qualified technician should install or open this motor.

Use 60/75°C Class 1 copper wire only.

10.2.1 Protective Features

Monitoring functions protect the motor against overtemperature of electronics, overtemperature of motor and incorrect rotor position detection. With any of these failures, an alarm will display through the Vertiv™ Liebert® iCOM™ controller and the motor stops electronically. There is no automatic restart. The power must be switched off for a minimum of 20 seconds once the motor is at a standstill.

The motor also provides locked rotor protection, undervoltage/phase failure detection and motor current limitation. These conditions will display an alarm through the Liebert® iCOM™.

10.2.2 Fan Impellers and Bearings Maintenance

Fan impellers should be periodically inspected and any debris removed. Check to ensure that the impellers can rotate freely and that the fan guards are still properly mounted for sufficient protection against accidentally contacting the impeller. Bearings used on the units are maintenance-free. Consult the factory for more information.

10.2.3 Fan Assembly Troubleshooting

Any safety hazards stemming from the device must be re-evaluated once it is installed in the end device.

Do not make any modifications, additions or conversions to the fan assembly without the approval of Vertiv.



WARNING! Risk of electric shock. Can cause serious injury or death. Open all local and remote electric power supply disconnect switches and verify that power is off with a voltmeter before working within any electric connection enclosures. The Vertiv™ Liebert® iCOM™ controller does not isolate power from the unit, even in the "Unit Off" mode. Fan-motor controls can maintain an electric charge for 10 minutes after power is disconnected. Wait 10 minutes after power is verified as off before working within the electric control/connection enclosures.

Installation, service, and maintenance work must be performed only by properly trained and qualified personnel and in accordance with applicable regulations and manufacturers' specifications. Opening or removing the covers to any equipment may expose personnel to lethal voltages within the unit even when it is apparently not operating and the input wiring is disconnected from the electrical source.



WARNING! Risk of contact with high-speed rotating fan blades. Can cause serious injury or death. Open all local and remote electric power-supply disconnect switches, verify with a voltmeter that power is off, and verify that all fan blades have stopped rotating before working in the unit cabinet or on the fan assembly. If control voltage is applied, the fan motor can restart without warning after a power failure. Do not operate the unit with any or all cabinet panels removed.

Do not operate upflow units without installing a plenum, ductwork or guard over the blower opening(s) on the top surface of the unit cabinet.

Ductwork must be connected to the blower(s) or a plenum must be installed on the blower deck for protection from rotating blower wheel(s) on upflow units.



CAUTION: Risk of exposure to harmful noise levels. Can cause hearing injury or loss. Depending on the installation and operating conditions, a sound pressure level greater than 70 dB(A) may arise. Take appropriate technical safety measures. Operating personnel must wear appropriate, OSHA-approved PPE and observe all appropriate hearing-protection safety requirements.



CAUTION: Risk of contact with hot surfaces. Can cause injury. The fan motor, and some electrical components are extremely hot during unit operation. Allow sufficient time for them to cool to a touch-safe temperature before working within the unit cabinet. Use extreme caution and wear appropriate, OSHA-approved PPE when working on or near hot components.

NOTICE

Risk of improper power-supply connection. Can cause equipment damage and loss of warranty coverage.

Prior to connecting any equipment to a main or alternate power source (for example: back-up generator systems) for start-up, commissioning, testing, or normal operation, ensure that these sources are correctly adjusted to the nameplate voltage and frequency of all equipment to be connected. In general, power-source voltages should be stabilized and regulated to within ±10% of the load nameplate nominal voltage. Also, ensure that no three-phase sources are single-phased at any time. See transformer label for primary tap connections. Installer will need to change transformer primary taps if applied unit voltage is other than pre-wired tap voltage.

NOTE: Do not assume that the fan blades will not start to spin. If the motor is in a fault condition, it will safely shut down. Once the fault condition is cleared, there are certain conditions in which the motor will automatically resume operation.

EC Fan Fault Conditions

Table 10.2 EC-fan Fault Conditions

Fault Condition	Reset Trigger	Description
Phase Failure	Automatic	One phase is missing. In this case the motor will come to a stop and then automatically restart when all phases are present.
Locked/Blocked Rotor	Automatic	The rotor is blocked. Once the locking mechanism has been removed, the motor will automatically restart.
Hall Effect Sensor Error	Manual (Mains/Software)	The Hall Effect Sensor is used to monitor fan speed. If there is a hall sensor communication failure with the electronics, the motor will stop. In this case there has to be a manual restart (either with the mains power or software).
Motor Over Temperature	Manual (Mains/Software)	The motor will stop in the event there is a motor over temperature condition. In this case there has to be a manual restart (either with the mains power or software).
Electronics Over Temperature	Manual (Mains/Software)	The motor will stop in the event there is an electronics over temperature condition. In this case there has to be a manual restart (either with the mains power or software).
Line Under-Voltage	Automatic	Once the line voltage returns within permitted operating range, the fan will automatically restart.

EC Fan High Voltage Tests

1. Check Fuses. If fuses are okay, perform the following:
 - Check all connections.
 - Make sure connections are on the wire strand and not on the wire insulation.
 - Cycle Power. Disconnect mains voltage to power down the motor and then re-apply power.
 - Check mains voltage at each phase (phase to ground) at the KL1 connector. Confirm phase failure not present.
 - Check that the voltage is within the acceptable voltage range at the KL1 connector. Confirm line under-voltage is not present.

2. Check fuses. If fuses are blown, perform the following:
 - Check resistances across the phases at the KL1 connector and note them in the following table.

NOTE: Power wires must be removed from the motor for resistance test.

Table 10.3 Resistances at KL1 Connector

L1 - L2		Ohm
L2 - L3		Ohm
L1 - L3		Ohm

- Resistances should be similar for all 3 readings.
- Resistance readings should be greater than 2 Ohm.
 - Check all connections. Make sure connections are on the wire strand and not on the wire insulation.
 - Replace fuses.
 - Check mains voltage at each phase (phase to ground) at the KL1 connector. Confirms phase failure not present.

Figure 10.3 KL1 Connector

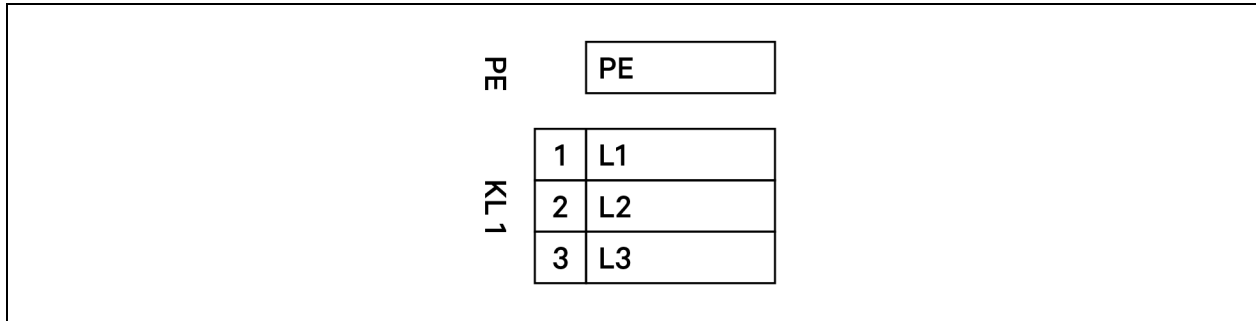

- Check that the voltage is within the acceptable voltage range at the KL1 connector. Confirms line under-voltage is not present.

EC Fan Low Voltage Tests

- Check control input at the KL3 connector (Ain1U to GND). Confirm that there is a control voltage present at the KL3 connector.

NOTE: Use the GND in the KL3 connector. Do not connect the control ground to the PE in KL1!

- Check +10 V output on KL3 connector (between +10 V and GND).

Figure 10.4 KL3 Connector

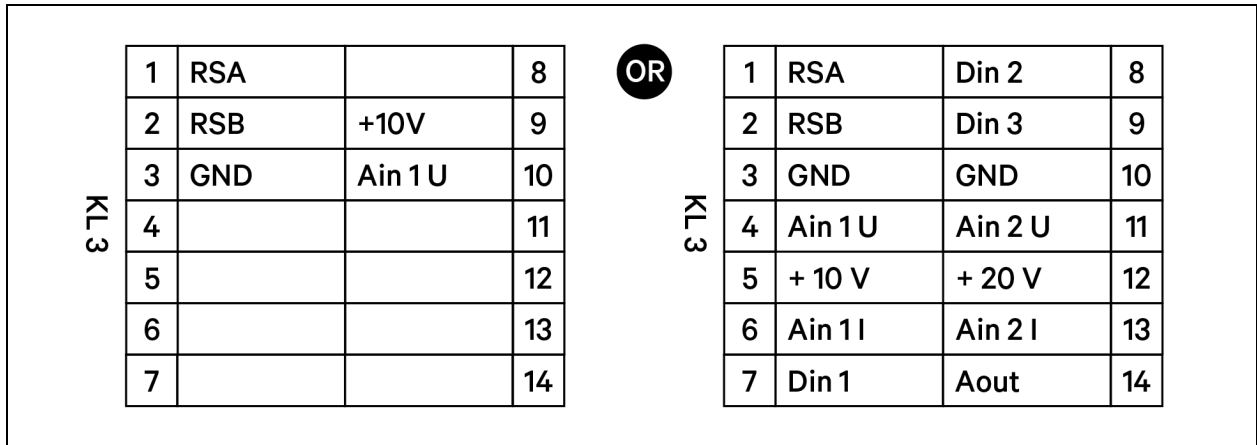

EC Fan Alarm Contact Tests

Check the alarm contact at KL2 to determine if there are any fault conditions present.

Figure 10.5 KL2 Connector

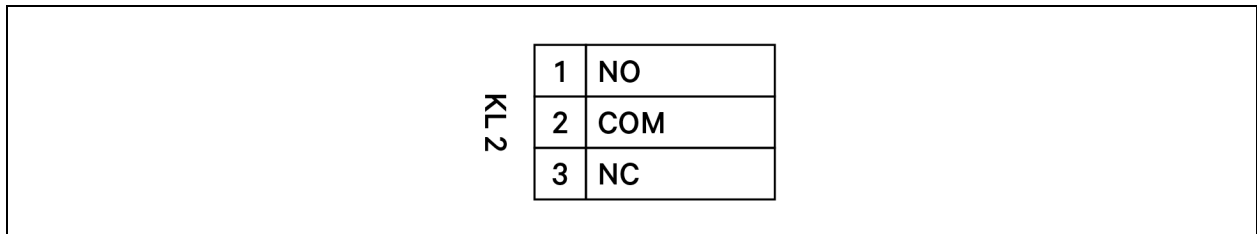

Table 10.4 No Fault/Fault Conditions while Motor Actively Energized

Condition	No Fault Condition	Fault Condition
NO - COM	Open	Closed
NC - COM	Closed	Open

NOTE: The table refers to conditions while the motor is actively energized. When the motor is de-energized, it will be in a fault condition.

- Check EC Control to determine the fault condition.

10.2.4 Removing EC Fans from Downflow Units

The EC fans in Vertiv™ Liebert® DS units can be removed for easier maintenance or for replacement.



WARNING! Risk of electric shock. Can cause serious injury or death. Open all local and remote electric power supply disconnect switches and verify with a voltmeter that power is off before working within the fan-motor electric-connection enclosures. Fan-motor controls can maintain an electric charge for 10 minutes after power is disconnected. Wait 10 minutes after power is verified as off before working within the electric control/connection enclosures. Use only fully-trained and qualified HVAC technicians to perform maintenance on the fans.



WARNING! Risk of contact with high-speed rotating fan blades. Can cause serious injury or death. Open all local and remote electric power-supply disconnect switches, verify with a voltmeter that power is off, and verify that all fan blades have stopped rotating before working in the unit cabinet or on the fan assembly. If control voltage is applied, the fan motor can restart without warning after a power failure. Do not operate the unit with any or all cabinet panels removed.



WARNING! Risk of extremely heavy fan modules dropping downward suddenly. Can cause injury or death. Fan modules weigh in excess of 125-lb (56.7-kg) each. Support fan modules before removing mounting hardware. Use caution to keep body parts out of fan module pathway of movement during removal. Only properly trained and qualified personnel should work on this equipment.

Read these instructions and unit labeling before removing fan modules. The instructions show a Liebert® DS with a 24-in. floorstand. Your unit may look slightly different.

Hardware and Tools Required

- 1/2" hex socket and wrench
- Factory-supplied jack, crank and jack support
- Cable tie cutter
- Field-supplied fan removal device capable of supporting fan assembly weight

To remove an EC fan module:

1. Remove panels from the front of the unit.
2. Remove the humidifier pan. You can remove fans without removing the humidifier pan, but removing it makes fan removal easier, see **Figure 10.6** on the next page .

Figure 10.6 Humidifier Pan Removal

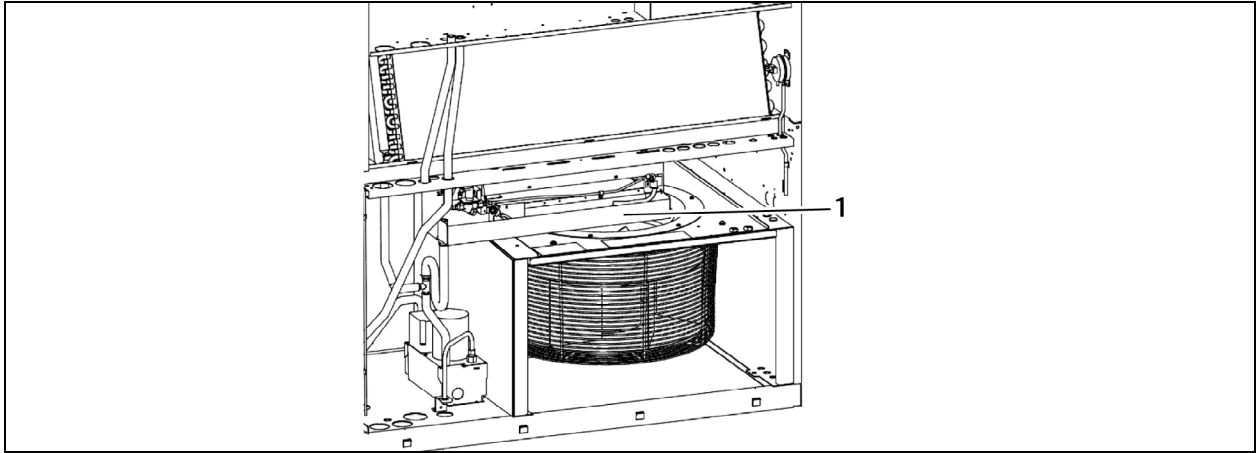

Item	Description
1	Humidifier pan

3. If the fan module is raised and in the unit, proceed to step 6.
 – or –

If the fan module is lowered into the floor stand, refer to **Figure 10.7** below and before removing any hardware, center the factory-supplied jack between the tabs on the jack support.

Figure 10.7 Jack Placement to Support EC Fan Module

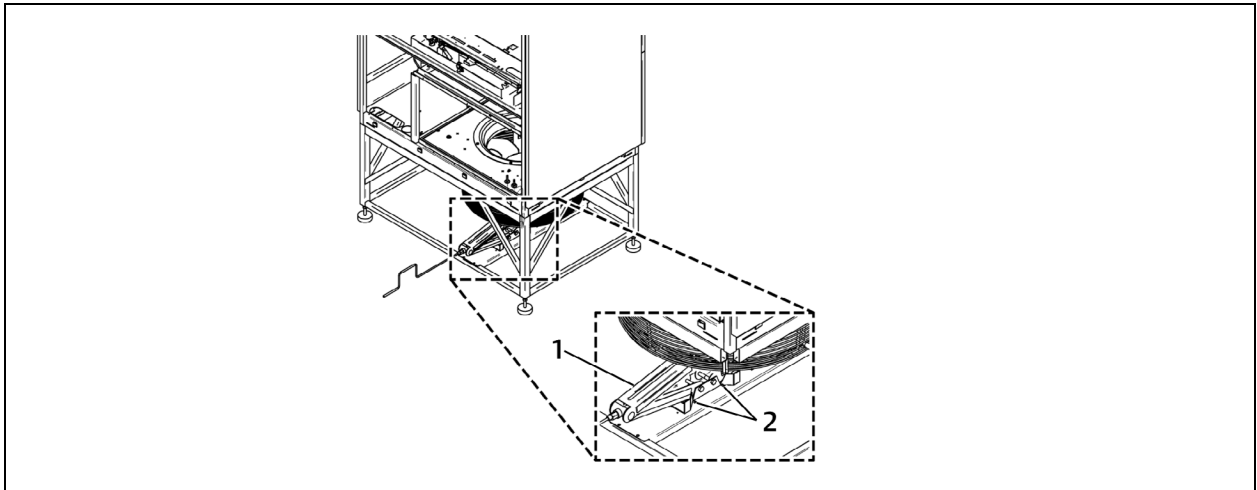

Item	Description
1	Position jack to support fan
2	Tabs

4. Remove hardware, **Figure 10.8** below, that retains the fan in the lowered position, and save it for re-installation.

NOTE: Hardware quantity and location varies depending on the type of unit.

Figure 10.8 Hardware Removal

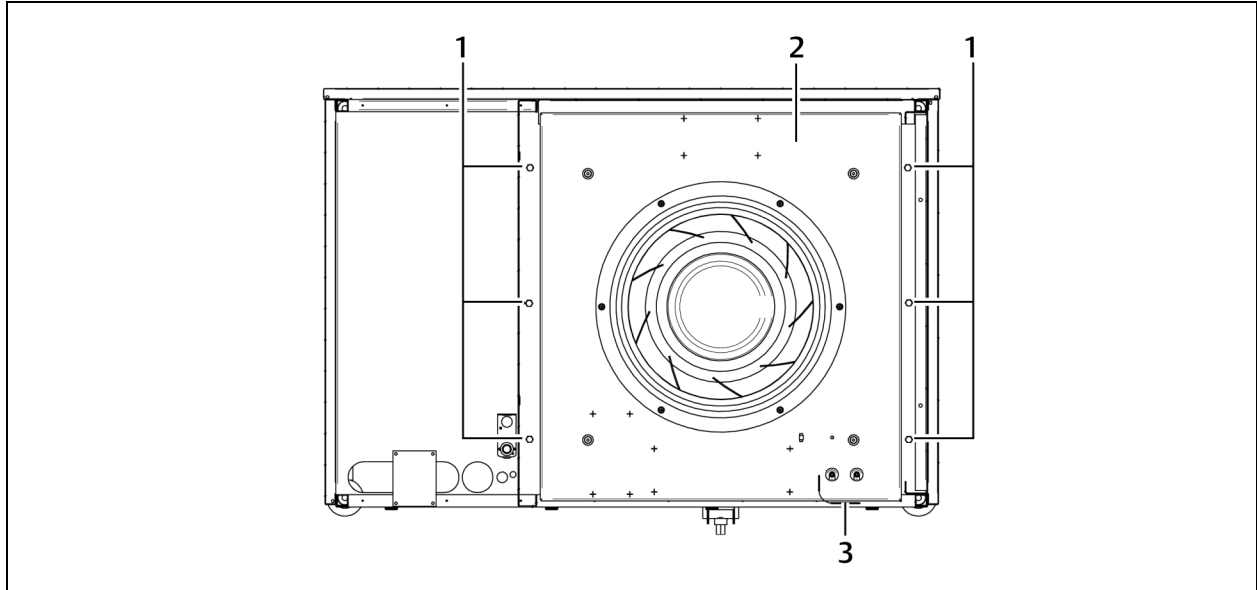

Item	Description
1	1/2-in. (13-mm) Hex-head bolts (typical both sides)
2	Fan deck
3	Wiring loop

5. Use the jack to raise the fan module slowly until the fan motor clears the front frame channel.
6. Insert a field-supplied fan-removal device securely on the front and rear frame channels under the fan module as shown in **Figure 10.9** on the next page .
- A suitable fan-removal device is two lengths of rigid material that is 4 inches (100 mm) wide and strong enough to support the weight of the fan module.

7. Disconnect high-voltage and low-voltage fan-motor wiring from the fan-motor electric component inside the electric panel. Cut cable ties as needed.
8. Using the removal device shown inserted in **Figure 10.9** below , slide the fan module out through the front of the unit.
9. To reinstall the fan module, reverse these steps. Remove the field-supplied fan-removal device before resuming operation.

NOTE: Refer to the unit's electrical schematic for specific wire-attachment points.

Figure 10.9 Slide EC Fan out of the Unit

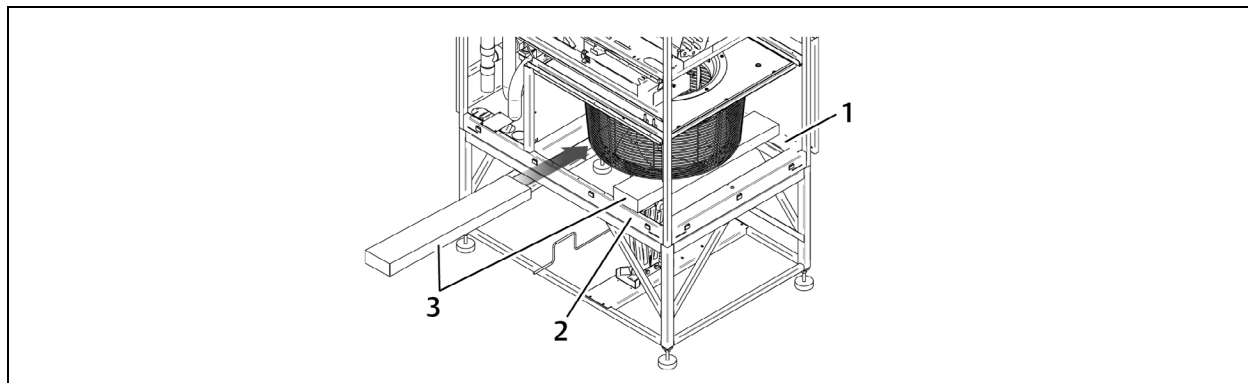

Item	Description
1	Rear frame channel (right-side panel not shown)
2	Front channel
3	Fan-removal devices

10.2.5 Removing EC Fans from Upflow Units



WARNING! Risk of electric shock. Can cause serious injury or death. Open all local and remote electric power supply disconnect switches and verify with a voltmeter that power is off before working within the fan-motor electric-connection enclosures. Fan-motor controls can maintain an electric charge for 10 minutes after power is disconnected. Wait 10 minutes after power is verified as off before working within the electric control/connection enclosures. Use only fully-trained and qualified HVAC technicians to perform maintenance on the fans.



WARNING! Risk of contact with high-speed rotating fan blades. Can cause serious injury or death. Open all local and remote electric power-supply disconnect switches, verify with a voltmeter that power is off, and verify that all fan blades have stopped rotating before working in the unit cabinet or on the fan assembly. If control voltage is applied, the fan motor can restart without warning after a power failure. Do not operate the unit with any or all cabinet panels removed.



WARNING! Risk of extremely heavy fan modules dropping downward suddenly. Can cause injury or death. Fan modules weigh in excess of 125-lb (56.7-kg) each. Support fan modules before removing mounting hardware. Use caution to keep body parts out of fan module pathway of movement during removal. Only properly trained and qualified personnel should work on this equipment. More than one person may be required to complete the assembly and installation. Installer(s) must be properly trained and qualified to lift, move and manipulate very heavy equipment from floor level to the top of the unit. Wear appropriate, OSHA-approved PPE when moving, lifting, installing, and removing the fan(s) and plenum. Read and follow the lifting equipment and/or ladder manufacturer's operating instructions and safety requirements.

NOTE: We recommend using a duct lift or scissors lift when installing or removing the EC-fan assemblies on top of the unit.

1. Disconnect the black-sleeved low-voltage harness and the green-sleeved high-voltage harness from the junction box, **Figure 10.10** below .

Figure 10.10 EC Fan Junction Boxes

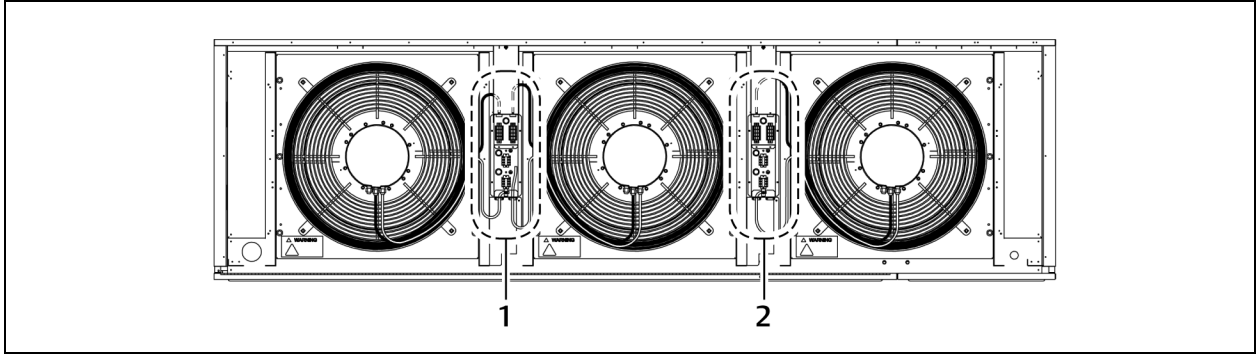

Item	Description
1	Junction box between fans 1 and 2 on 2- and 3-fan unit
2	Junction box for 1- or 3-fan unit

2. Locate the 6 places where the EC-fan assembly attaches to the unit, **Figure 10.11** below , and remove the bolts, washers and spacers, **Figure 10.12** on the facing page .

Figure 10.11 Assembly in Place on the Unit

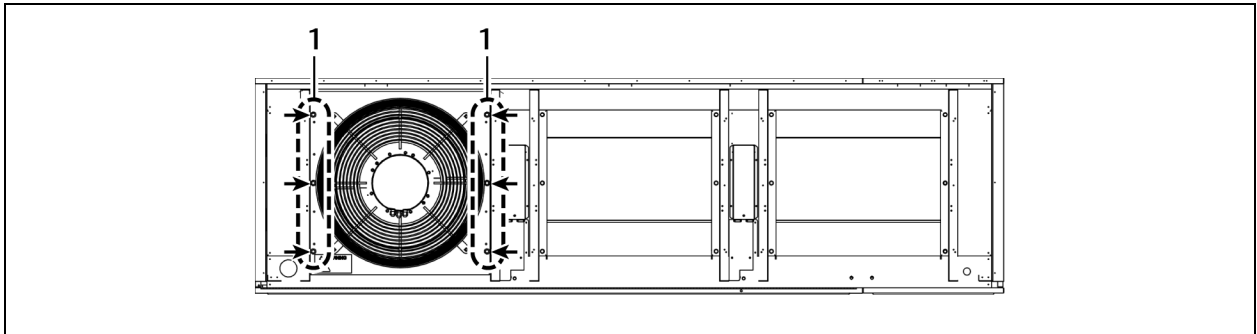

Item	Description
1	Mounting holes

Figure 10.12 Bolts, Washers, and Spacers on EC Fan Assembly (6 Places)

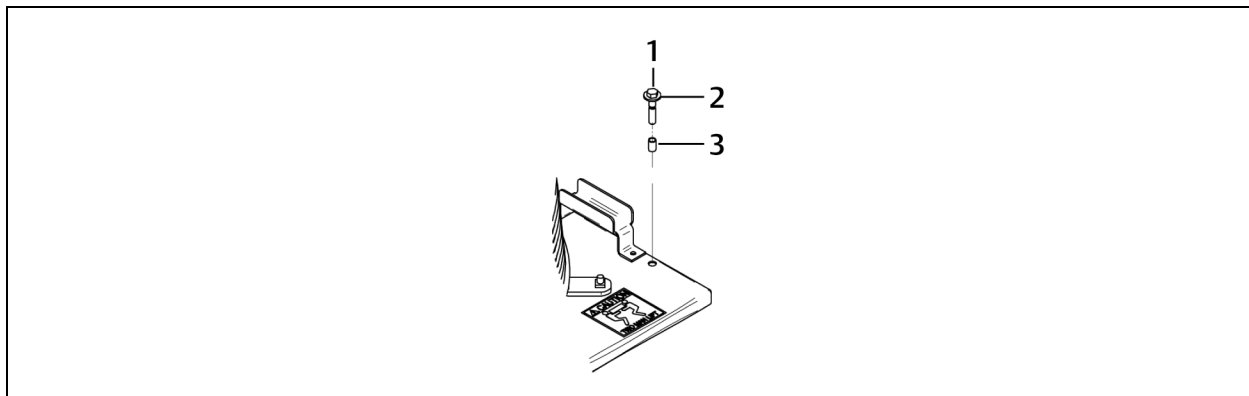

Item	Description
1	Bolt
2	Washer
3	Spacer

3. Position the lifting device so that it lines-up with the EC-fan assembly.

NOTE: A minimum clearance of 36 in. (914 mm) from the bottom of the unit to the top of the plenum is required for component access.

4. Using the handles on the EC-fan assembly, carefully lift the assembly over the hinge along the top of the unit, and slide the assembly onto the lifting device, **Figure 10.13** below.
5. Use the lifting device to lower the EC-fan assembly for transport to service or maintenance area.

Figure 10.13 EC Fan Assembly Moved onto Lifting Device

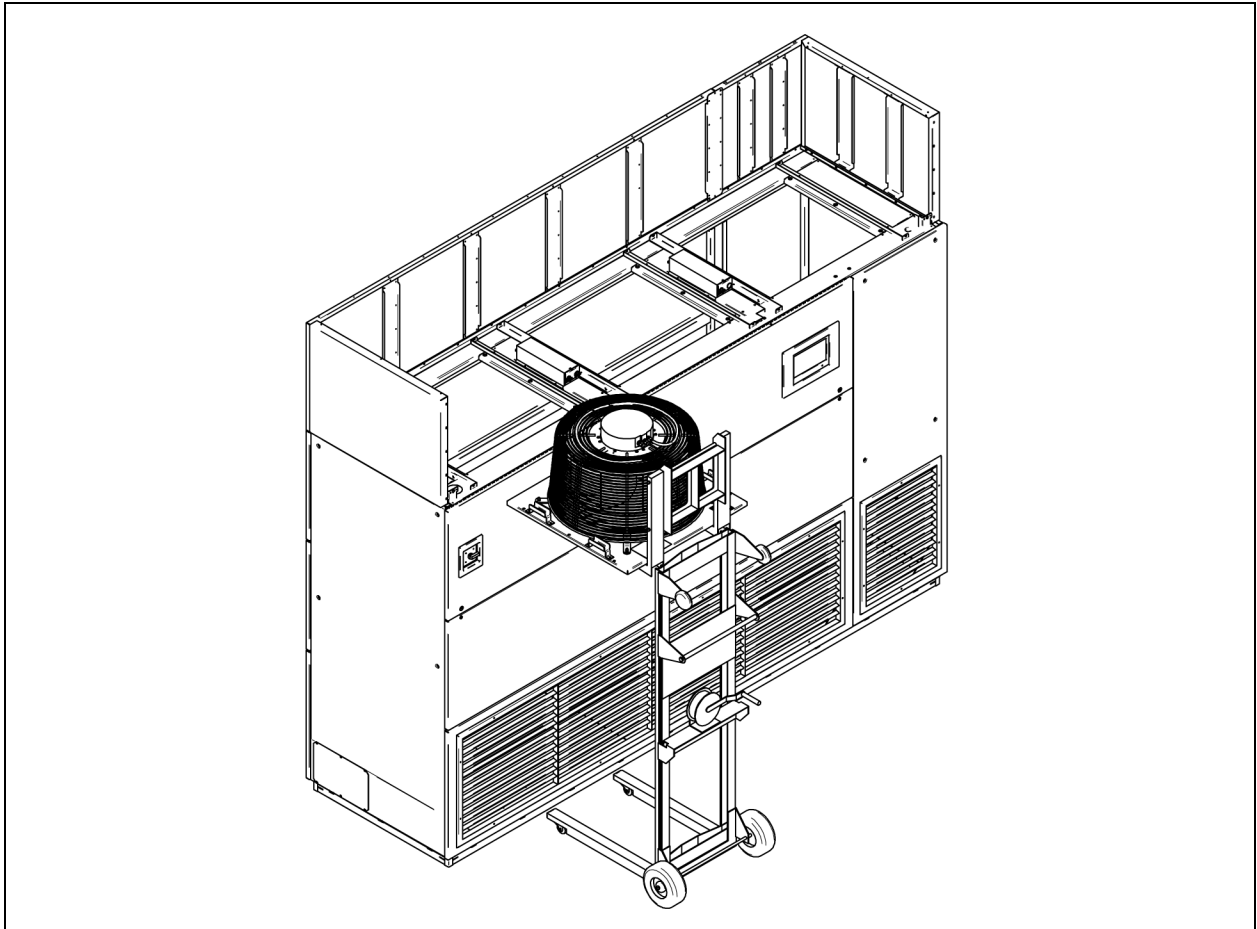

10.3 Blower Drive System—Forward Curved Blowers

Blower drive system components that are part of the maintenance schedule include the blower wheels drive shaft, bearings, pulley, belts, sheave, motor auto-tension base and motor.



WARNING! Risk of improper drive-belt removal. Can cause serious injury or death. If improperly handled, the spring-loaded motor base can slam down suddenly causing serious injury to hands and fingers from crushing and pinching. Read the directions in this manual and on the unit instruction labels. Keep hands and fingers away from pinch points. Wear appropriate, OSHA-approved PPE when performing maintenance on the belts, motors or pulleys. Follow all directions when servicing the unit.

10.3.1 Upflow Motor Access

1. Remove the lateral support (sheet metal channel) under electric box by removing two screws at each end.
2. Removed the hinged dead-front panel (30-ton units have open access to the motor).
3. Remove two screws on the right side of the low-voltage electric box that secure the low volt electric box to the sheet metal shoulder.
4. Swing open low-voltage electric box to gain access to the motor.

Figure 10.14 Upflow Motor Access

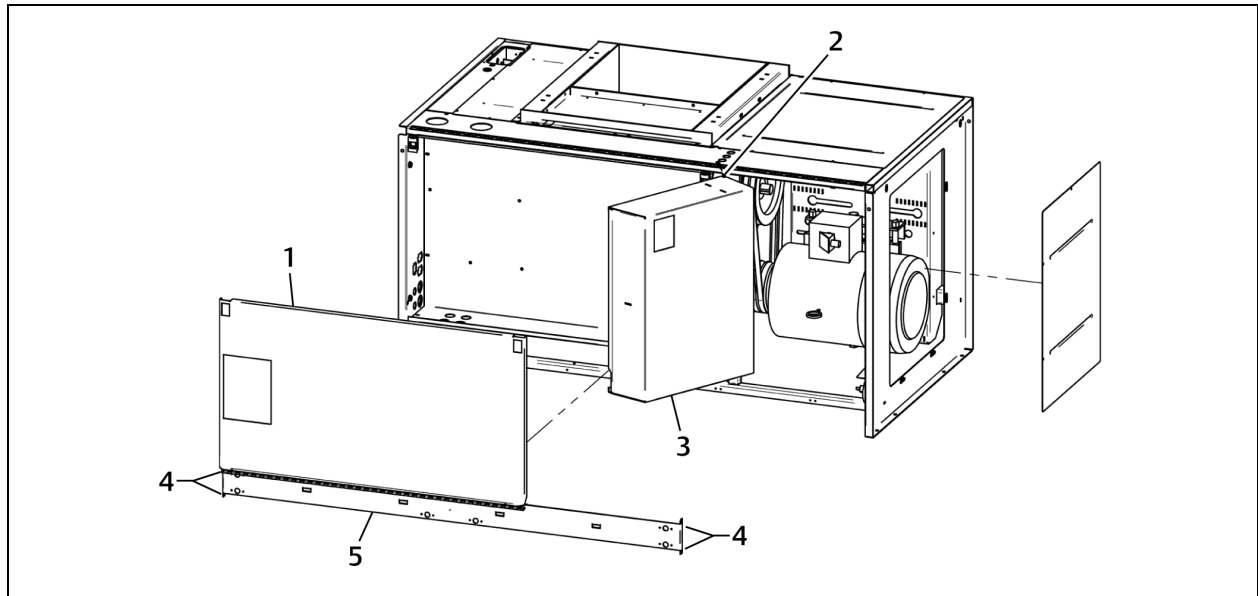

Item	Description	Item	Description
1	Dead front	4	Screws
2	Hinge	5	Lateral support
3	Low-voltage electric box		

10.3.2 Belt Removal

1. Disconnect power to unit.

NOTE: Do not pry the belts off sheave or pulley.

2. Refer to instruction labels on unit near motor base.
3. Turn adjustment nut (see [Auto Belt Tensioning Motor Base](#) on the facing page) counterclockwise (left) to loosen belts and bring motor base internal spring out of compression.
4. Remove belts.

10.3.3 Belt Installation and Tensioning

1. Select the appropriate replacement of belts (matched set) and position on drive package.
To maximize performance and reliability of Vertiv™ Liebert® DS equipment, use only belts supplied by Vertiv. Contact your Vertiv sales representative for replacement belts.
2. Ensure pulley grooves are properly aligned. If adjustment is required, loosen (do not remove) four nuts in adjustment slots (see [Auto Belt Tensioning Motor Base](#) on the facing page) holding motor base to unit frame and slide motor base assembly into alignment.
3. Tension belts by turning adjustment nut clockwise (right) until motor base carriage stops moving downward.
4. Ensure minimum 1/2-in. (13 mm) clearance exists from motor-base carriage to base front flange (see [Auto Belt Tensioning Motor Base](#) on the facing page). If the clearance is less than 1/2 in (13 mm), select shorter belts.
5. Mark the adjustment nut and rotate clockwise (right) 5 additional full turns. This sets internal spring for proper belt tension, no readjustments necessary.

Figure 10.15 Auto Belt Tensioning Motor Base

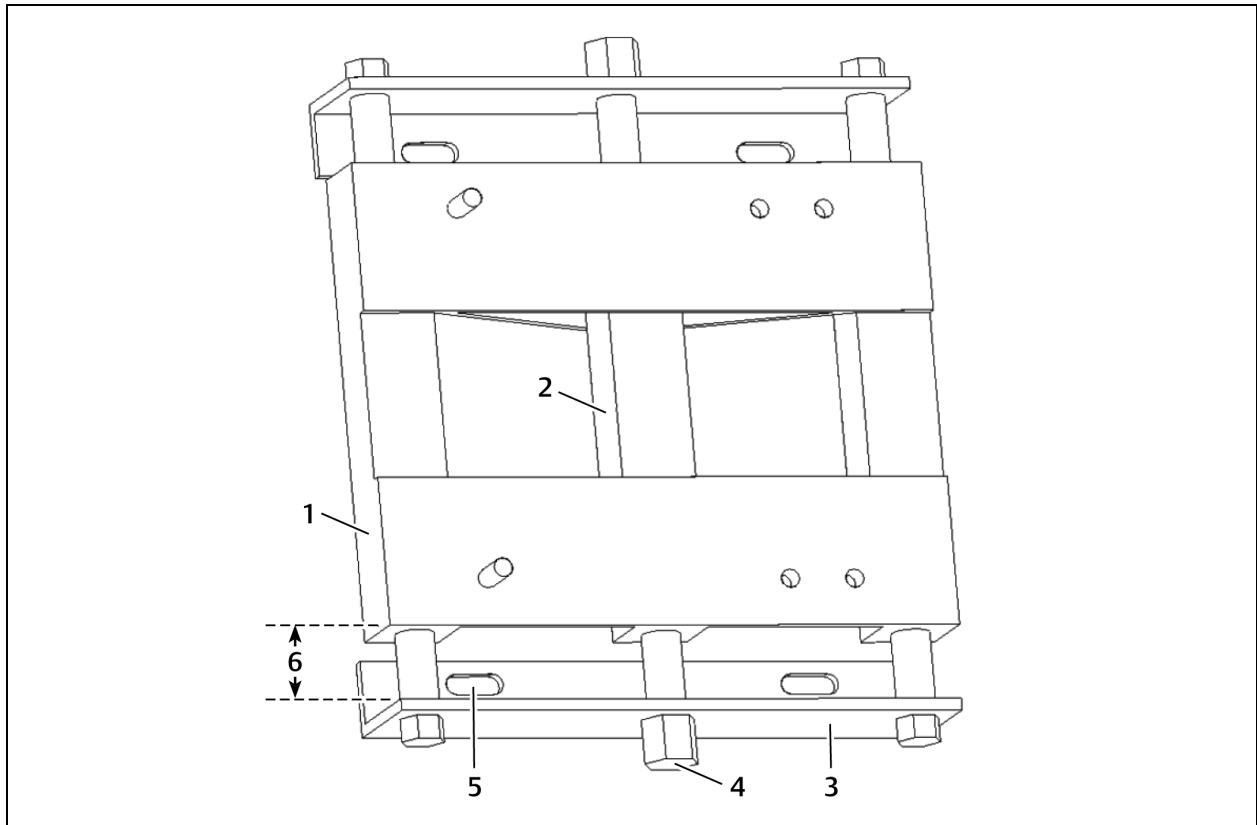

Item	Description	Item	Description
1	Motor base carriage	4	Adjustment nut
2	Spring housing	5	Motor-plate adjustment slot
3	Motor plate	6	Minimum gap = 1/2 in. (13 mm)

10.3.4 Blower Bearing Maintenance

- Field lubrication is NOT required for the life of the bearing.
- Bearings are permanently sealed and self-lubricating and cannot be greased.

10.3.5 Blower Bearing Inspection

1. Disconnect power to unit.
2. Remove drive belts (see [Belt Removal](#) on the previous page).
3. Inspect bearing for tightness of set screws and mounting bolts.
4. Rotate fan wheel by hand.
5. Listen for *unusual* noise and look for signs of *unusual* play.

10.3.6 Blower Bearing Replacement

1. To maximize performance and reliability of Vertiv™ Liebert® DS equipment, use only SealMaster® Reduced Maintenance pillow block bearing with tapered lands race and double lock set screws. Contact your local sales representative to order replacement bearings.
2. Properly mount and align bearings on shaft. Tighten set-screws in proper sequence and to proper torque using a torque wrench in accordance with the manufacturer's instructions.

10.3.7 Blower Motor

Inspect motor at regular intervals. Keep motor clean and ventilation openings clear of dust, dirt and other debris.

10.3.8 Blower Motor Lubrication

- Motor is lubricated at the factory and does not require initial lubrication.
- Contact the motor manufacturer for the lubrication interval for motor bearings that have grease fittings.
- Contact the motor manufacturer to determine what type of grease to use for lubrication. Greases of different bases may not be compatible when mixed.

10.3.9 Blower Wheel

Check to see if wheels are tightly mounted on fan shaft. Rotate wheels and make sure they do not rub against fan housing. The wheels should be periodically cleaned of dirt and debris.

10.4 Infrared Humidifier Maintenance

During normal humidifier operation, deposits of mineral solids will collect in humidifier pan and on the float switch. These must be cleaned periodically to ensure proper operation. Frequency of cleaning must be locally established since it is dependent on humidifier usage and local water quality. A spare pan is recommended to reduce maintenance time at unit. The autoflush system can greatly increase the time between cleanings, but does not eliminate the need for periodic checks and maintenance (see Vertiv™ Liebert® iCOM™ user manual SL-31075 for autoflush setup). To help reduce excessive scaling in locations with difficult water quality, the use of Vapure™ is recommended (contact your local sales representative).



WARNING! Arc flash and electric shock hazard. Can cause serious injury or death. Building and equipment damage may also result. Disconnect all local and remote electric power supplies and wear appropriate, OSHA-approved personal protective equipment (PPE) per NFPA 70E before working within the electric control enclosure. Customer must provide earth ground to unit, per NEC, CEC and local codes, as applicable.

Verify with a voltmeter that power is Off. The Vertiv™ Liebert® iCOM™ controller does not isolate power from the unit, even in the “Unit Off” mode. Some internal components still require and receive power even during the “Unit Off” mode of the Liebert® iCOM™ controller. The factory-supplied, optional disconnect switch is inside the unit. The line side of this switch contains live high voltage. The only way to ensure that there is NO voltage inside the unit is to install and open a remote disconnect switch. Refer to unit electrical schematic.

Before proceeding with installation, read all instructions, verify that all the parts are included and check the nameplate to be sure the voltage matches available utility power. Follow all local codes.



WARNING! Risk of electric shock. Can cause serious injury or death. Building and equipment damage may also result. Open all local and remote electric power supply disconnect switches and verify that power is off with a voltmeter before working within any electric connection enclosures. The Liebert® iCOM™ controller does not isolate power from the unit, even in the "Unit Off" mode. Some internal components require and receive power even during the "unit off" mode of the Liebert® iCOM™ controller .

Installation, service, and maintenance work must be performed only by properly trained and qualified personnel and in accordance with applicable regulations and manufacturers' specifications. Opening or removing the covers to any equipment may expose personnel to lethal voltages within the unit even when it is apparently not operating and the input wiring is disconnected from the electrical source.



CAUTION: Risk of contact with hot surfaces. Can cause injury. Personal burn injury can be the result of touching a humidifier reservoir pan and/or water contained within the pan, and some electrical components that are extremely hot during unit operation. Allow sufficient time for them to cool to a touch-safe temperature before working within the unit cabinet.

Use extreme caution and wear appropriate, OSHA-approved PPE when working on or near hot components, including when replacing or performing maintenance on the infrared humidifier parts inclusive of its bulbs, metal enclosure, humidifier reservoir pan and/or water contained within the pan, and drain tubing. All infrared humidifier parts are very hot during and remain very hot shortly after operation.



CAUTION: Risk of improper handling of boiling water. Can cause leaks, equipment and building damage, or burn injury. The unit requires a drain line that may contain boiling water. Only properly trained and qualified personnel wearing appropriate, OSHA-approved PPE should service the drain line or work on parts near or connected to the drain line.

10.4.1 Cleaning Humidifier Pan and Float Switch

Before turning the unit Off:

1. With unit operating, remove call for humidification at the Vertiv™ Liebert® iCOM™ control.
2. Let the blower operate 5 minutes to allow the humidifier and water to cool.
3. If unit has a condensate pump, turn unit OFF at Liebert® iCOM™ control.
4. Pull out the humidifier standpipe in pan.
5. Inspect the O-ring (replace if necessary).
6. Let the pan drain and condensate pump operate (if applicable).
7. Disconnect power from the unit.
8. Disconnect the drain coupling from the bottom of the pan.
9. Remove the thermostat from the bottom of the pan and the retaining screws from the sides of the pan.
10. Slide the pan out.
11. Loosen scale on side and bottom of pan with a stiff nylon brush or plastic scraper.
12. Flush with water.
13. Carefully clean scale off float switch (make sure to reinstall correctly (see **Figure 10.16** on the facing page).
14. Reinstall the pan, thermostat, standpipe, drain coupling and screws into the humidifier.
15. Operate the humidifier and check for leaks.

Figure 10.16 Correct Float Switch Orientation

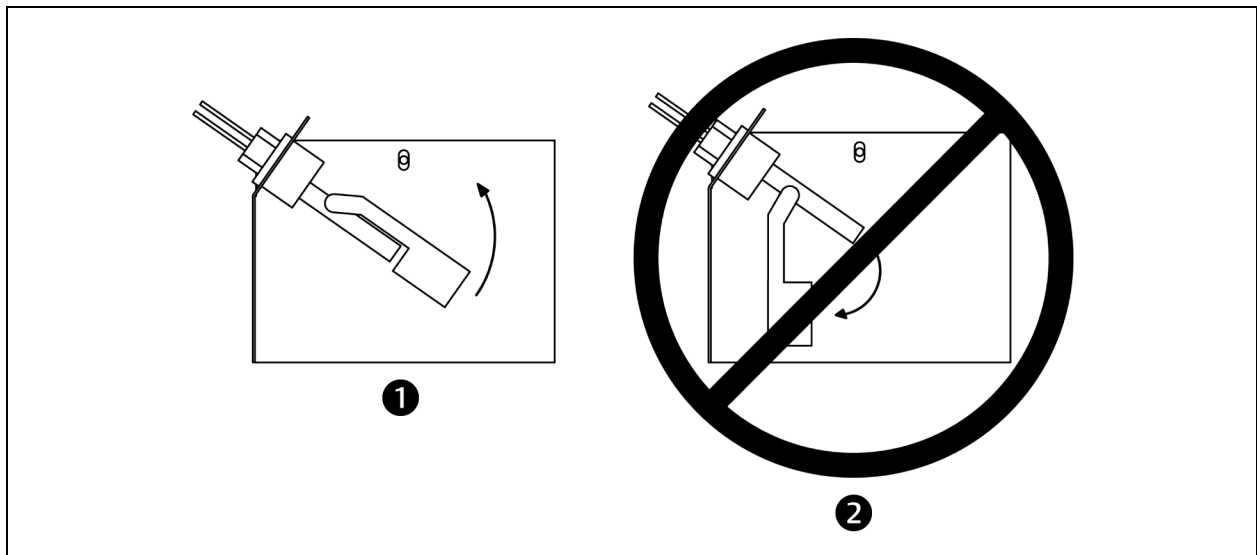

Item	Description
1	Correct switch orientation
2	Incorrect switch orientation

10.4.2 Changing Humidifier Lamps

NOTE: Touching quartz lamps with bare hands will severely shorten bulb life. Skin oils create hot spots on lamp surface. Wear clean cotton gloves when handling lamps.

The lamps are shown in [Figure 10.17](#) on the next page .

1. Remove humidifier pan (see [Cleaning Humidifier Pan and Float Switch](#) on the previous page , steps 1 through 10).
2. Disconnect power from unit.
3. At humidifier, remove screws and cover from high-voltage compartment.
4. Disconnect one end of purple jumper wires.
5. Using a continuity meter, locate burned out lamp.
6. Remove lamp brackets under lamps.
7. Loosen two screws securing lamp lead wires to junction block.
8. Pull bulb straight down and discard.
9. Wrap lead wires once around new lamp's metal ends. This will support lamp and allow for thermal expansion. Insert lead wires into junction block and torque screws to 30 in-lb.
10. Reassemble by reversing steps 1 through 9 .

Figure 10.17 Infrared Humidifier Lamps

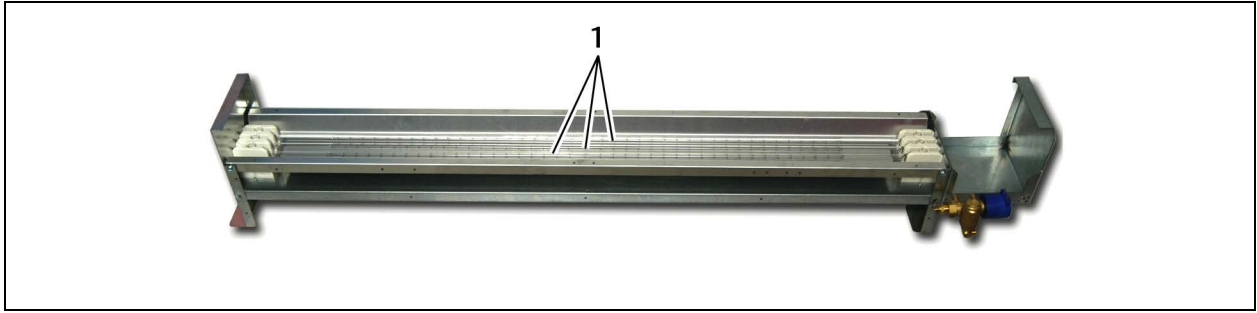

Item	Description
1	Infrared bulbs

10.5 Condensate Drain and Condensate Pump System Maintenance

10.5.1 Condensate Drain

Check for and clear obstructions in tubing during routine maintenance.

10.5.2 Condensate Pump



WARNING! Risk of electric shock. Can cause serious injury or death. Open all local and remote electric power supply disconnect switches and verify that power is off with a voltmeter before working within any electric connection enclosures. The Vertiv™ Liebert® iCOM™ controller does not isolate power from the unit, even in the "Unit Off" mode. Condensate pump will stay energized and has the potential to operate even in the "Unit Off" mode.

Installation, service, and maintenance work must be performed only by properly trained and qualified personnel and in accordance with applicable regulations and manufacturers' specifications. Opening or removing the covers to any equipment may expose personnel to lethal voltages within the unit even when it is apparently not operating and the input wiring is disconnected from the electrical source.

To maintain the condensate pump:

1. Disconnect power to the unit using the disconnect switch.
2. Check for and clear obstructions in gravity lines leading to the condensate pump.
3. Remove the sump, clean with a stiff nylon brush and flush with water.
4. Inspect and clear clogs in the discharge check valve and float mechanism.
5. Reassemble and check for leaks.

10.6 Air Cooled Condenser and Drycooler Maintenance

Restricted airflow will reduce operating efficiency and could result in high compressor-head pressure and loss of cooling.

- Clear coil surface of all debris that will inhibit airflow.
- Check for bent or damaged coil fins and correct.
- Do not permit snow to accumulate around or under outdoor unit.
- Periodically consider commercial cleaning of coil surface.
- For condensers and drycoolers with coil coating, see the heat rejection manual for specific instructions on cleaning and maintenance requirements.
- Inspect fans, motors and controls for proper operation.
- Check all piping and capillaries for proper support.
- Inspect for leaks.
- Check contactors for pitting. Replace if pitted.

10.7 Electric Reheat Maintenance

- Inspect and clean reheat elements.
- Inspect and tighten support hardware.

10.8 Thermostatic Expansion Valve (TXV) Maintenance

The TXV performs one function: It keeps the evaporator supplied with enough refrigerant to satisfy load conditions. It does not affect compressor operation.

Proper valve operation can be determined by measuring superheat. The correct superheat setting is . If too little refrigerant is being fed to the evaporator, the superheat will be high. If too much refrigerant is being supplied, the superheat will be low.

10.8.1 Determining Suction Superheat

To determine superheat:

1. Measure the temperature of the suction line at the point the TXV bulb is clamped.
2. Obtain the gauge pressure at the compressor suction valve.
3. Add the estimated pressure drop between the bulb's location and the suction valve.
4. Convert the sum of the two pressures to the equivalent temperature.
5. Subtract this temperature from the actual suction line temperature. The difference is superheat.

10.8.2 Adjusting Superheat Setting with the TXV

To adjust the superheat setting:

1. Remove the valve cap at the bottom of the valve.
2. Turn the adjusting stem counterclockwise to lower the superheat.
3. Turn the adjusting stem clockwise to increase the superheat.

NOTE: Make no more than one turn of the stem at a time. Allow up to 15 minutes of fully loaded compressor operation before checking superheat or making additional stem adjustments.

10.9 Compressor Maintenance



WARNING! Risk of electric shock. Can cause serious injury or death. Building and equipment damage may also result. Open all local and remote electric power supply disconnect switches and verify that power is off with a voltmeter before working within any electric connection enclosures. The Vertiv™ Liebert® iCOM™ controller does not isolate power from the unit, even in the "Unit Off" mode. Some internal components require and receive power even during the "unit off" mode of the Liebert® iCOM™ controller .

Installation, service, and maintenance work must be performed only by properly trained and qualified personnel and in accordance with applicable regulations and manufacturers' specifications. Opening or removing the covers to any equipment may expose personnel to lethal voltages within the unit even when it is apparently not operating and the input wiring is disconnected from the electrical source.



WARNING! Risk of over-pressurization of the refrigeration system. Can cause serious injury or death. Building and equipment damage may also result. Can cause explosive discharge of high-pressure refrigerant, loss of refrigerant, or environmental pollution. This unit contains fluids and gases under high pressure. Use extreme caution when charging the refrigerant system. Do not pressurize the system higher than the design pressure marked on the unit's nameplate.



WARNING! Risk of explosive discharge of high-pressure refrigerant. Can cause serious injury or death. Building and equipment damage may also result. Neutral and service ports on the compressor service valves do not have a valve core. Front-seat the service valves and relieve pressure from the compressor before loosening a part or a component attached to the service valve. Follow local codes to properly reclaim refrigerant.

10.9.1 Compressor Oil

NOTICE

Risk of improper compressor lubrication. Can cause compressor and refrigerant system damage.

Failure to use oil types, viscosities and quantities recommended by the compressor manufacturer may reduce compressor life and void the compressor warranty.

See oil types specified in **Table 10.5** on the facing page .

- Do not mix polyolester (POE) and mineral-based oils.
- Do not mix oils of different viscosities.
- Consult Vertiv technical support or the compressor manufacturer if questions arise.

Table 10.5 Compressor Oil types for R-407C Refrigerant

Compressor Type	Oil Type
Carlyle Semi-hermetic	POE Oil - ISO 68 Viscosity ¹
Copeland Scroll and Digital-scroll	POE Oil - ISO 32 Viscosity ²
1. Use Carlyle POE Oil Totaline P903-1001, Castrol SW68 or other Carlyle-approved oils. 2. Use Copeland POE Oil ULTRA 32-3MAF or other Copeland-approved oils. Source: DPN003950 Rev. 5	

NOTE: See [Additional Oil Requirements for Scroll and Digital Scroll Compressors](#) on page 41, for additional oil based on the system's refrigerant charge.

10.9.2 Scroll and Digital Scroll Compressor Maintenance

Hermetic scroll and digital scroll compressors do not have an oil sight glass.

NOTE: Refer to [Additional Oil Requirements for Scroll and Digital Scroll Compressors](#) on page 41, for approved oil types and additional oil required based on the system's refrigerant charge.

10.9.3 Semi-Hermetic Compressor Maintenance

Oil level can be viewed at the sight glass on semi-hermetic compressors. Normal operating oil level is 1/4 to 3/4 up the sight glass.

After a compressor has been idle for an extended length of time, foaming will usually be present when compressor first starts. Wait until compressor has been operating for at least five minutes before viewing the oil level.

If oil level is low, the cause must be corrected and oil level returned to its proper level.

10.9.4 Replacement Compressors

Replacement compressors are available through your Vertiv sales office. If the unit is under warranty, the replacement compressor must be obtained from and the original compressor returned to your local Vertiv sales office. Compressors are shipped in reusable packaging, and the original compressor should be returned in the same packaging.

10.9.5 Rotalock Valve on Scroll and Digital-Scroll Compressors



WARNING! Risk of explosive discharge of high-pressure refrigerant. Can cause serious injury or death. Building and equipment damage may also result. Neutral and service ports on the compressor service valves do not have a valve core. Front-seat the service valves and relieve pressure from the compressor before loosening a part or a component attached to the service valve. Follow local codes to properly reclaim refrigerant.

- The Neutral port remains open to the compressor side in all positions of the valve stem, see **Figure 10.18** on the next page. A high-pressure cut-out switch or low-pressure switch/transducer will be connected to this port.
- The Service port is closed to the system when valve stem is back-seated, see **Figure 10.18** on the next page. It is open to the system as soon as the valve is adjusted away from the back-seated position.

Figure 10.18 Rotalock Valve

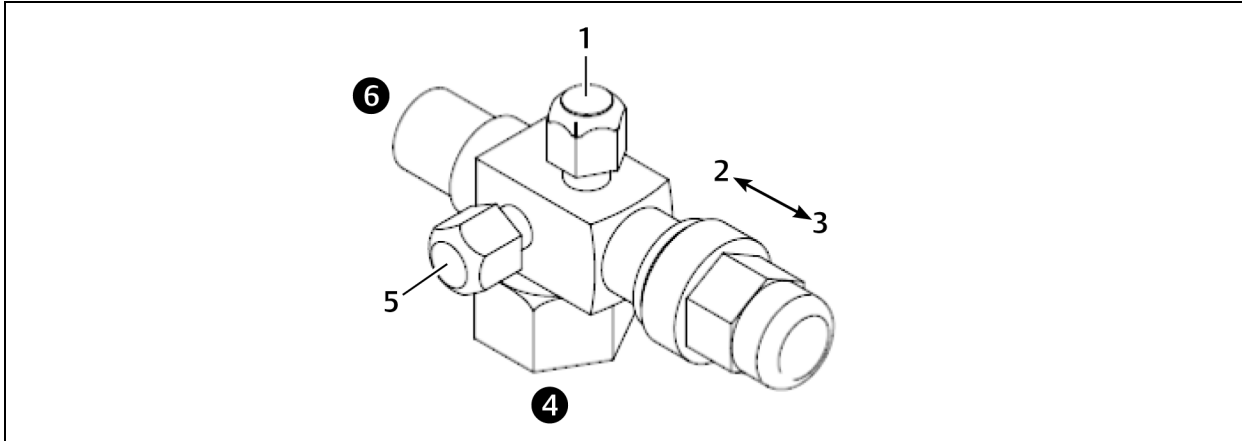

Item	Description
1	Service port (gauge)
2	Front seat
3	Back seat
4	Compressor side of valve
5	Neutral port
6	System side of valve

10.9.6 Unloading Solenoids on a Digital Scroll Compressor

On Models 035 and 042:

When replacing a digital-scroll compressor, the digital solenoid valve and coil must be replaced. The compressor and valve kit are shipped separately. The valve kit must be field-brazed to the top of the compressor in proper orientation and supported with the original factory bracket.

On Models 053 and 070:

When replacing a digital-scroll compressor, digital solenoid coil must be replaced. Compressor and coil kit are shipped separately.

10.9.7 Compressor Electrical Failure (Motor Burnout)

If a burnout has occurred, a full system clean-out is required. If not cleaned, compressor and system problems will continue.

Consult the factory for compressor maintenance. Do not attempt to remove the compressor without first contacting Vertiv support at 1-800-543-2778.

10.9.8 Replacing a Compressor with Electrical Failure (Motor Burnout)



WARNING! Risk of electric shock. Can cause serious injury or death. The Vertiv™ Liebert® iCOM™ microprocessor does not isolate power from the unit, even in the "Unit Off" mode. Some internal components require and receive power even during the "unit off" mode of the Liebert® iCOM™ control. Open all local and remote electric power disconnect switches and verify with a voltmeter that power is Off before working on any component of the system.



WARNING! Risk of over-pressurization of the refrigeration system. Can cause serious injury or death. Building and equipment damage may also result. Can cause explosive discharge of high-pressure refrigerant, loss of refrigerant, or environmental pollution. This unit contains fluids and gases under high pressure. Use extreme caution when charging the refrigerant system. Do not pressurize the system higher than the design pressure marked on the unit's nameplate.

NOTE: Release of refrigerant to the atmosphere is harmful to the environment. Refrigerant must be recycled or discarded in accordance with federal, state, and local regulations.

1. Attach suction and discharge gauges to access fittings.
2. Front-seat service valves to isolate the compressor. Recover refrigerant using an approved recovery procedure and equipment. Use a filter drier when charging the system with recovered refrigerant.
3. Remove marked pressure transducer and discharge pressure switch. Disconnect all electrical connections.
4. Detach service valves from compressor.
5. Remove failed compressor.
6. Follow compressor manufacturer's suggested clean-out procedures.
7. Install replacement compressor and make all connections. Replace gaskets or seals on service valves. Replace unloading solenoid.
8. Evacuate, charge and operate per the appropriate procedure per local codes:
 - [Evacuation, Leak Testing, and Charging Air Cooled Systems without Vertiv™ Liebert® Lee-Temp Receivers](#) on page 44
 - [Evacuation, Leak Testing, and Charging Air Cooled Systems with Vertiv™ Liebert® Lee-Temp "Flooded Condenser" Head Pressure Control System](#) on page 49 .
 - Water/Glycol-cooled units should be charged with refrigerant amount as shown on the serial tag, using standard industry charging procedures for self-contained R-407C units.

NOTICE

Risk of improper component re-installation. Can cause equipment damage.

Identify and mark location of suction pressure transducer and discharge pressure switch. These devices look similar and they must be reinstalled in their original location.

10.9.9 Compressor Mechanical Failure

If mechanical failure of the compressor has occurred, only the compressor needs replaced. A full system clean-out is not required.

10.9.10 Replacing a Compressor with Mechanical Failure



WARNING! Risk of electric shock. Can cause serious injury or death. The Vertiv™ Liebert® iCOM™ microprocessor does not isolate power from the unit, even in the "Unit Off" mode. Some internal components require and receive power even during the "unit off" mode of the Liebert® iCOM™ control. Open all local and remote electric power disconnect switches and verify with a voltmeter that power is Off before working on any component of the system.



WARNING! Risk of over-pressurization of the refrigeration system. Can cause serious injury or death. Building and equipment damage may also result. Can cause explosive discharge of high-pressure refrigerant, loss of refrigerant, or environmental pollution. This unit contains fluids and gases under high pressure. Use extreme caution when charging the refrigerant system. Do not pressurize the system higher than the design pressure marked on the unit's nameplate.

NOTE: Release of refrigerant to the atmosphere is harmful to the environment. Refrigerant must be recycled or discarded in accordance with federal, state, and local regulations.

1. Front-seat service valves to isolate the compressor. Recover refrigerant using an approved recovery procedure and equipment
2. Remove failed compressor.
3. Keep the replacement compressor sealed until installation is complete to the point that the system isolation valves are ready to be engaged. Keep exposure of the POE oil in compressor to atmosphere to a minimum.
4. Install replacement compressor, replace gaskets or seals on service valves, and make all connections. Replace unloading solenoid if equipped.
5. Once the compressor is completely installed, keep isolation valves closed to the system and open to compressor. Add dry nitrogen to compressor and check all connections for leaks. With no leaks confirmed, evacuate the isolated compressor prior to introducing to the rest of the system.
6. When evacuating the isolated compressor volume, pull a vacuum of 500 microns with no decay above 1000 microns within 20 minutes.
Once evacuation requirements of compressor are met, open the valves to open the compressor to the system.
7. Check compressor and system operation. Make any necessary adjustments for proper equipment operation.

10.10 Motorized Ball Valve (MBV) Maintenance (Digital Scroll Compressors)

Discharge pressure is controlled by a motorized ball valve. During unloaded operation, the pressure changes during each digital cycle could result in excessive repositions with a pressure operated water regulating valve. The control algorithm for the motorized ball valve uses an intelligent sampling rate and adjustable pressure thresholds to reduce valve repositions. The valve assembly consists of the brass valve, linkage and actuator.

10.10.1 MBV Control

The valve actuator operates on 24 VAC power and is controlled by a 2 to 10 VDC proportional control signal. The valve full-open to full-close time is 60 seconds. At 2 VDC the valve is closed; at 10 VDC the valve is fully open. There is a 20-second delay to position the motorized ball valve before starting the compressor.

10.10.2 MBV Control Method

The control utilizes an upper and lower pressure threshold with a 35 psi (241 kPa) deadband to reduce valve movement. If the liquid pressure is between the upper and lower threshold the valve remains at the current position. If the liquid pressure exceeds the upper threshold the valve opens, and if the pressure falls below the lower threshold the valve closes. There are multiple adjustment bands to ease discharge pressure back into control range.

10.10.3 MBV Adjustment

Both pressure thresholds can be shifted simultaneously over a 50 psi (35 kPa) range (the 35 psi [241 kPa] differential remains constant). The ball valve setpoint offset parameter in the Service menu can be adjusted from 0 to 50 psi (345 kPa) to raise or lower the control band similar to the pressure adjustment on a water regulating valve. Changing the setpoint offset will adjust the pressure thresholds for both circuits. Units are factory set at a 30 psi (207 kPa) setpoint offset (30 psi [207 kPa] above minimum). This results in a 220 psiA (1517 kPa) lower threshold and a 255 psiA (1758 kPa) upper threshold pressure.

10.10.4 MBV Start-up

The setpoint offset is adjusted to the minimum value during start up, then transitions to the set value once the compressor reaches normal operating pressures. Due to the control dead band it is possible for each circuit to stabilize at different pressures within the dead band. Additionally changes in fluid temperature could cause pressure changes that do not result in valve movement within the dead band. Drycooler aquastats should be set to prevent continuous fluid temperature swings greater than 10°F (5.6°C) (see [Vertiv™ Liebert® Drycooler Aquastat Settings](#) on page 126).

10.10.5 MBV Location

The motorized ball valves are located in the condenser fluid return line. Three-way valves are piped in a mixing arrangement with the common port at the valve outlet.

10.10.6 MBV Manual Control

The valve can be manually set by disconnecting AC power, depressing the manual override button on the valve actuator, and adjusting the valve position with the handle. Motorized ball valves may be controlled through the Service menu using manual mode to override the normal control.

10.11 Facility Fluid and Piping Maintenance for Water and Glycol Systems

Maintaining the system fluid quality is required throughout the life of the system. Fluid and piping system maintenance schedules must be established and performed. A coolant-fluid maintenance program must be established that will evaluate fluid chemistry and apply necessary treatment. The complexity of water/glycol solution condition problems and the variations of required treatment programs make it extremely important to obtain the advice of a competent and experienced water-treatment specialist and follow a regularly-scheduled coolant-fluid system-maintenance program.

Perform periodic inspections of the facility and the unit coil and/or heat exchanger and coolant-fluid piping system for leaks and visible damage.

10.12 Glycol Solution Maintenance

It is difficult to establish a specific schedule of inhibitor maintenance because the rate of inhibitor depletion depends upon local water conditions. Analysis of water samples at the time of installation and through a maintenance program should help to establish a pattern of depletion. A visual inspection of the solution and filter residue is often helpful in judging whether active corrosion is occurring.

The complexity of water/glycol solution condition problems and the variations of required treatment programs make it extremely important to obtain the advice of a competent and experienced water-treatment specialist and follow a regularly-scheduled coolant-fluid system-maintenance program. It is important to note that improper use of water treatment chemicals can cause problems more serious than using none. Proper inhibitor maintenance must be performed in order to prevent corrosion of the glycol system. Consult the glycol manufacturer for testing and maintenance of inhibitors. Do not mix products from different manufacturers.

10.13 Vertiv™ Liebert® Paradenser—Water Cooled Condenser Maintenance

During normal Liebert® Paradenser operation, deposits will collect on the inside wall of condenser tubes. It must be cleaned periodically to ensure proper operation. Frequency of cleaning must be locally established because it varies according to Liebert® Paradenser usage and local fluid quality. See [Facility Fluid and Piping Maintenance for Water and Glycol Systems](#) on the previous page .

10.13.1 Cleaning the Liebert® Paradenser

1. Disconnect power to unit.
2. Close field-installed isolation valves to isolate this unit's condenser system from facility water or glycol circuit.
3. Remove access panel from front of compressor section.
4. Locate the 1/2" NPT drain plugs located at lower front of compressor section and provide means to collect fluid drained from system
5. Remove the 1/2" drain plugs using two wrenches to prevent damage to drain lines.
6. Locate and remove the 3" diameter clean out plugs on top of shell assemblies (use 1-3/16" drag link socket or similar).
7. Brush and flush each of the nominal 5/8" inner diameter, rifled copper tubes. Recommend using John R. Robinson, Inc. or similar:
 - Motorized Tube Cleaner, Model JR3800-1200
 - Nylon brush 9/16" diameter, Model JRRB211N-916
 - Flexible shaft, Model JRRFS702-25
8. Reinstall 1/2" drain plugs 6 to 7 turns using Loctite 567 PST Thread Sealant as instructed by the manufacturer.
9. Wipe clean the machine threads and sealing surfaces of 3" diameter clean out plugs.
10. Remove and install new O-rings (Liebert® part number 180750P1) on the 3" diameter clean out plugs. (Do not use thread sealant).
11. Hand tighten 3" diameter clean out plugs and torque using drag link socket to 25 ft-lb. (33.9 Nm).
12. Leak check fluid system (refer to [Leak Checking for Unit and Field Installed Piping](#) on page 54).
13. Bleed system using Schrader ports near the top of the Liebert® Paradenser.
14. Ensure that condensing fluid isolation valves are fully open.
15. Unit is ready to be put on-line.

10.13.2 Water Regulating Valves Maintenance for Semi-Hermetic and Standard Scroll Compressors

The water regulating valves automatically regulate the amount of fluid necessary to remove the heat from the refrigeration system, permitting more water to flow when load conditions are high and less fluid to flow when load conditions are low. The valve consists of a brass body, balance spring, valve seat, valve disc holders, capillary tube to discharge pressure, and adjusting screw.

To adjust Johnson Controls valves:

The valves may be adjusted with a standard refrigeration service valve wrench or screwdriver.

Table 10.6 Recommended Refrigerant Pressures

System Design	PSIG (kPa)
Water-Cooled	
65 to 75°F water (18 to 24°C)	210 (1450)
85°F water (29°C)	225 (1550)
Glycol-Cooled	295 (2035)
Maximum	330 (2275)
High Pressure Cut-out	400 (2859)

To lower the head pressure setting, turn the square adjusting screw clockwise until the high pressure gauge indicates the desired setting. To raise the head pressure setting, turn the adjusting screw counterclockwise until the desired setting is obtained. Consult the factory if your unit is equipped with valves from other manufacturers.

To Test the Function of the Valve:

First, turn off the refrigeration system. When the refrigeration system has been off for approximately 10 to 15 minutes, the water flow should stop. If the water continues to flow, the valve is either improperly adjusted (with head pressure too low) or the pressure-sensing capillary is not connected properly to the condenser.

To Locate the Valve:

The water regulating valves are located in the condenser fluid supply line.

10.14 Vertiv™ Liebert® Drycooler Aquastat Settings

Applications with the Optional Stat Setting require field piping to be insulated to prevent condensation. **Table 10.7** below, shows acceptable applications where stats must be adjusted to Optional Setting.

Aquastats must be field-adjusted to Optional Setting for:

- Vertiv™ Liebert® GLYCOOL/Dual Cool applications

Table 10.7 Water/Glycol System Conditions Requiring Optional Settings for Aquastats

Flow Control:	MBV				WRV			
Cooling Type:	Glycol		GLYCOOL		Glycol		GLYCOOL	
Drycoolers in Loop	1	Multiple	1	Multiple	1	Multiple	1	Multiple
Stat Setting*	Optional	Factory	Optional	Optional	Factory	Factory	Optional	Optional
Insulate Field Piping	Yes	No	Yes	Yes	No	No	Yes	Yes
* See Table 10.8 below through Table 10.10 on the facing page								
MBV = motorized ball valve, WRV = water regulating valve								

Table 10.8 Aquastat Settings—2 Fan through 4 Fan Liebert® Drycoolers

Dial Setting (Stat Open Temp) Set for Mid Differential 8°F (4.4°C) Rise to Close			
Aquastat #	Fans	Factory Setting (Glycol) (see Notes 1 and 2)	Optional Setting (GLYCOOL) (see Note 3)
AQ1	F1	65°F (18.3°C)	35°F (1.7°C)
AQ2	F2 & F3	75°F (23.9°C)	45°F (7.2°C)
AQ3	F44	70°F (21.1°C)	40°F (4.4°C)
<ol style="list-style-type: none"> 1. All Liebert® Drycoolers are shipped at Factory Setting. 2. Factory Setting is used for all glycol applications, except single Liebert® Drycooler loops with motor ball valve controls. 3. Stats must be field-adjusted to Optional Setting for GLYCOOL/Dual Cool applications and all single Liebert® Drycooler loops using motorized-ball-valve flow controls. 			
Source: DPN0001602 Rev. 5			

Table 10.9 Aquastat Settings—6 Fan Vertiv™ Liebert® Drycooler

Dial Setting (Stat Open Temp) Set for Mid Differential 8°F (4.4°C) Rise to Close				
Aquastat #	Fans	Stat Location Cabinet	Factory Setting (Glycol) (see Notes 1 and 2)	Optional Setting (GLYCOOL) (see Note 3)
AQ1	F1	Main	65°F (18.3°C)	35°F (1.7°C)
AQ2	F2	Main	70°F (21.1°C)	40°F (4.4°C)
AQ3	F3 & F4	Auxiliary	73°F (22.8°C)	43°F (6.1°C)
AQ4	F5 & F6	Auxiliary	75°F (23.9°C)	45°F (7.2°C)

1. All drycoolers are shipped at Factory Setting.

2. Factory Setting is used for all glycol applications, except single Liebert® Drycooler loops with motor ball valve controls.

3. Stats must be field-adjusted to Optional Setting for GLYCOOL/Dual Cool applications and all single drycooler loops using motor ball valve flow controls.

Source: DPN0001602 Rev. 5

Table 10.10 Aquastat Settings—8 Fan Liebert® Drycooler

Dial Setting (Stat Open Temp) Set for Mid Differential 8°F (4.4°C) Rise to Close				
Aquastat #	Fans	Stat Location Cabinet	Factory Setting (Glycol) (see Notes 1 and 2)	Optional Setting (GLYCOOL) (see Note 3)
AQ1	F1	Main	65°F (18.3°C)	35°F (1.7°C)
AQ2	F2	Main	70°F (21.1°C)	40°F (4.4°C)
AQ3	F3 & F4	Auxiliary	73°F (22.8°C)	43°F (6.1°C)
AQ4	F5 & F6	Auxiliary	75°F (23.9°C)	45°F (7.2°C)
AQ5	F7 & F8	Main	78°F (25.6°C)	48°F (8.9°C)

1. All drycoolers are shipped at Factory Setting.

2. Factory Setting is used for all glycol applications, except single Liebert® Drycooler loops with motor ball valve controls.

3. Stats must be field-adjusted to Optional Setting for GLYCOOL/Dual Cool applications and all single drycooler loops using motor ball valve flow controls.

Source: DPN0001602 Rev. 5

This page intentionally left blank

11 Preventive Maintenance Checklist

Source: DPN002952, Rev. 4

Inspection Date	Job Name
Indoor Unit Model #	Indoor Unit Serial Number #
Condenser/Drycooler Model #	Condenser/Vertiv™ Liebert® Drycooler Serial #
Room Temperature/Humidity	Ambient Temperature

Not all units will have all components. To determine your unit's configuration, compare the [Indoor Unit Model #](#) above and the information in the Components and Nomenclature section.

Good maintenance practices are essential to minimizing operation cost and maximizing product life. Read and follow all applicable maintenance checks listed below. At a minimum, these checks should be performed semi-annually. However, maintenance intervals may need to be more frequent based on site-specific conditions. Review the unit user manual for further information on unit operation. We recommend the use of trained and authorized service personnel, extended service contracts, and factory certified replacement parts. Contact your local sales representative for more details.

Check all that apply:

Evaporator/Filters

1. Check/replace filters.
2. Grille area is unrestricted.
3. Wipe section clean.
4. Coil clean.
5. Clean condensate pan.
6. Clean trap in condensate drain.
7. Check/test filter-clog switch operation (if equipped).

Blower Section (EC Fan)

1. Mounting bolts tight
2. Fan guard bolts tight
3. Impeller spins freely
4. Check/test air sail switch (if equipped)
5. Motor amp draw
 - Compare to nameplate amps

#1	L1	L2	L3
#2	L1	L2	L3
#3	L1	L2	L3

Blower Section (Forward Curved)

1. Blower wheels free of debris.
2. Check belt tension and condition (replace if needed).
3. Check/lube bearings (Vertiv™ Liebert® DS bearings are sealed and do not require lubrication even though grease fittings are present.)
4. Check/lube motor (if supplied with grease ports). Check motor manufacturer’s web site for procedure, amount and type of grease required.
5. Check sheave/pulley. (Replace if worn.)
6. Check motor mount.
7. Check/Test air sail switch.
8. Motor amp draw.
 - Compare to nameplate amps.

#1	L1	L2	L3
#2	L1	L2	L3
#3	L1	L2	L3

Reheat

1. Inspect elements.
2. Check wire connections. (Inside reheat box.)
3. Reheat amp draw.

L1	L2	L3
L1	L2	L3
L1	L2	L3

Condensate Pump (if Equipped)

1. Check for debris in sump.
2. Check operation of floats for free movement.
3. Check/clean discharge check valve.

Electrical Panel

1. Check fuses
2. Check contactors for pitting, replace if pitted.
3. Check/re-torque wire connections

Controls

1. Check/verify control operation sequence.
2. Check/test changeover devices, if equipped.
3. Check/test water-detection devices, if equipped.
4. Check/test CAN connection between indoor and outdoor units, if equipped.

Refrigeration Piping

1. Check refrigerant lines: clamps are secure, no rubbing, and no leaks.
2. Check for moisture (sight glass).
3. Check for restriction temperature drop across filter drier.

Compressor Section

1. Check oil level.
2. Check for oil leaks.
3. Check compressor mounts (springs and bushings).
4. Check tubes (not rubbing).
5. Check/re-torque wire connections inside compressor box.
6. Compressor operation (vibration/noise).
7. Check crank-case heater fuses/operation.
8. Check for refrigerant leaks.

9. Suction pressure	Circuit #1	_____	Circuit #2	_____
10. Discharge Pressure	Circuit #1	_____	Circuit #2	_____
11. Superheat	Circuit #1	_____	Circuit #2	_____
12. Low-pressure switch cut out	Circuit #1	_____	Circuit #2	_____
13. Low pressure cut in	Circuit #1	_____	Circuit #2	_____
14. High pressure cut out	Circuit #1	_____	Circuit #2	_____

15. Amp draw

Circuit #1A	L1	L2	L3
Circuit #1B (if tandem)	L1	L2	L3
Circuit #2A	L1	L2	L3
Circuit #2B (if tandem)	L1	L2	L3

Water Cooled Condensers (if Equipped)

1. Verify proper water maintenance/treatment is being performed.
2. Check water regulating valve (motorized ball valve) operation.
3. Verify water flow.
4. Clean screen on Y strainer, if equipped.
5. Cap tubes (not rubbing).
6. Check condenser and supply/return lines/connections for water/glycol leaks.
7. Entering water temperature _____°.
8. Leaving water temperature _____°.

Chilled Water/Vertiv™ Liebert® Econ-o-Coil (if Equipped)

1. Verify proper water maintenance is being performed.
2. Check coil and supply/return lines/connections for water/glycol leaks.
3. Stroke free-cooling valve open and closed.

Vertiv™ Liebert® MC Condenser

1. Coil clean of debris , clean coil if required.
2. Fans free of debris.
3. Fans securely mounted
4. Motor bearings in good condition.
5. Check all refrigerant lines for vibration isolation. Support as necessary.
6. Check for refrigerant leaks.
7. Check surge-protection device status-indicator lights, if installed.
8. Check/re-torque wire connections.
9. Check contactors for pitting and replace if pitted.
10. Verify operation sequence/set points.
11. Charge verification:
 - a. Outdoor ambient temperature _____
 - b. Subcooling _____
 - c. Indoor unit Return air temperature _____
 - d. Sight glass level (if Vertiv™ Liebert® Lee-Temp or pumped refrigerant) _____
12. Motor amp draw

#1	L1	L2	L3
#2	L1	L2	L3
#3	L1	L2	L3
#4	L1	L2	L3
#5	L1	L2	L3
#6	L1	L2	L3
#7	L1	L2	L3
#8	L1	L2	L3
#9	L1	L2	L3
#10	L1	L2	L3
#11	L1	L2	L3
#12	L1	L2	L3
#13	L1	L2	L3
#14	L1	L2	L3
#15	L1	L2	L3
#16	L1	L2	L3

Vertiv™ Liebert® Drycooler (if Equipped)

1. Coil clean free of debris.
2. Motor mounts tight.
3. Motor bearings in good condition.
4. Piping support/clamps secure.
5. Check/re-torque wire connections.
6. Check contactors for pitting and replace if pitted.
7. Check fuses.
8. Verify fan operation.
9. Check surge-protection device status-indicator lights, if equipped.
10. Stat settings _____
11. Refrigerant level (Liebert® Lee-Temp)
12. Glycol level.
13. Glycol solution -----%
14. Water/glycol solution flowing continuously/clean and free of debris
15. Water treatment plan established and followed for open cooling-tower application
16. Check refrigerant/glycol lines for signs of leaks and repair as found.
17. Motor amp draw

#1	L1	L2	L3
#2	L1	L2	L3
#3	L1	L2	L3
#4	L1	L2	L3

Glycol Pump (if Equipped)

1. Check pump rotation.
2. Check pump and supply/return lines/connections for leaks.
3. Pump pressures.

#1	Suction	Discharge
#2	Suction	Discharge
#3	Suction	Discharge

4. Amp Draw

#1	L1	L2	L3
#2	L1	L2	L3
#3	L1	L2	L3

5. Verify pump changeover (if multiple pumps)

Appendices

Appendix A: Technical Support and Contacts

A.1 Technical Support/Service in the United States

Vertiv Group Corporation

24x7 dispatch of technicians for all products.

1-800-543-2378

Liebert® Thermal Management Products

1-800-543-2378

Liebert® Channel Products

1-800-222-5877

Liebert® AC and DC Power Products

1-800-543-2378

A.2 Locations

United States

Vertiv Headquarters

505 N. Cleveland Ave.

Westerville, OH, 43082, USA

Europe

Via Leonardo Da Vinci 8 Zona Industriale Tognana

35028 Piove Di Sacco (PD) Italy

Asia

7/F, Dah Sing Financial Centre

3108 Gloucester Road

Wanchai, Hong Kong

This page intentionally left blank

Appendix B: Disassembling the Vertiv™ Liebert® DS for Transport

The Liebert® DS has a modular frame construction that allows separating the unit into three sections. Each of these sections is more easily maneuvered through tight spaces or placed in small elevators.

A qualified service technician with the required tools and recommended assistance can disassemble an air-cooled unit in about four hours, assuming refrigerant evacuation is not required.

This procedure requires four or more people for lifting the filter and electric box assembly on downflow units and for lifting the blower and electric box assembly on upflow units.



WARNING! Risk of over-pressurization of the refrigeration system. Can cause serious injury or death. Building and equipment damage may also result. Can cause explosive discharge of high-pressure refrigerant, loss of refrigerant, or environmental pollution. This unit contains fluids and gases under high pressure. Use extreme caution when charging the refrigerant system. Do not pressurize the system higher than the design pressure marked on the unit's nameplate.



WARNING! Risk of top-heavy unit falling over when improperly lifted or moved. Can cause serious injury or death. Building and equipment damage may also result. Read all of the following instructions and verify that all lifting and moving equipment is rated for the weight of the unit before attempting to move, lift, remove packaging from or prepare the unit for installation. Unit weights are specified in **Table 3.3** on page 20 .



CAUTION: Risk of contact with sharp edges, splinters, and exposed fasteners. Can cause injury. Only properly trained and qualified personnel wearing appropriate, OSHA-approved PPE should attempt to move, lift, remove packaging from or prepare the unit for installation.



CAUTION: Risk of improper handling heavy and lengthy parts. Can cause injury. Building and equipment damage may also result. Follow relevant OSHA lifting recommendations and consider using a two-person lift for safe and comfortable removal and installation of cabinet panels. Only properly trained and qualified personnel wearing appropriate, OSHA-approved PPE should attempt to remove or install cabinet panels.

NOTICE

Risk of improper disassembly. Can cause equipment damage.

Disassembling this unit requires substantial work, including reclaiming refrigerant and charging the unit, cutting and brazing refrigerant lines, cutting and brazing water lines, disconnecting and reconnecting electrical lines and moving heavy, bulky equipment. One member of the crew disassembling the unit must be qualified in wiring, brazing and refrigeration.

Improperly disassembling or reassembling the Liebert® DS may affect warranty.

The disassembly dimensions and details are described in the submittal documents included in the [Submittal Drawings](#) on page 147.

The following table lists the relevant documents by number and title.

Table B.1 Disassembly Dimension Drawings

Document Number	Title
Downflow Units	
DPN003647	Disassembly Dimensional Data Downflow 35-42 kW (10-12 Tons) Models with Scroll and Digital Scroll Compressors
DPN003648	Disassembly Dimensional Data Downflow 53-77kW (15-22 Tons) Models
DPN003649	Disassembly Dimensional Data Downflow 105kW (30 Tons) Models
Upflow Units	
DPN003650	Disassembly Dimensional Data Upflow 35-42kW (10-12 Tons) Models with Scroll and Digital Scroll Compressors
DPN003657	Disassembly Dimensional Data Upflow 53-77kW (15-22 Tons) Models
DPN003658	Disassembly Dimensional Data Upflow 105kW (30 Tons) Models

B.1 Required Equipment

- Piano jacks
- Stepladder
- Refrigeration tools

B.2 Disassembly—Downflow Units

1. Remove the unit from its shipping skid before beginning. Refer to [Unpacking the Unit](#) on page 25.
2. Remove all panels except the top front accent.
3. Remove all filters. This allows access to the screws for metal plate blocking off the top coil and removal of the filter plate.
4. All wires are hot-stamped and all circuit board connectors are lettered to ease connection. Some cable ties must be cut and replaced. Refer to the unit’s wiring schematic on the unit’s dead-front panel for details.

NOTICE

Risk of oil loss or displacement. Can cause compressor damage.

Do not lay the compressor section on its side. It must remain upright. The coil section also must remain upright.

5. Label the three quick-connect plugs from the compressor compartment and disconnect them.
6. Disconnect the compressor wire harness, including the crankcase heater wires, if present, from the contactor in the electric box.
7. Pull the conduit and wires into the compressor compartment.
8. Disconnect the fan motor wire harness from the bottom of the contactor in the electric box.
9. Pull the conduit and wires into the bottom section of the unit.
10. Reheat—Optional Component
 - a. Disconnect the reheat wire harness from the bottom of the contactor in the electric box.
 - b. Unplug the low-voltage quick connect for the reheat safety wires.
 - c. Pull the conduit and wires into the unit's blower and coil assembly section.
11. Humidifier—Optional Component
 - a. Disconnect the humidifier wire harness from the bottom of the contactor in the electric box.
 - b. For infrared humidifiers: Remove the quick-connect plugs from the following low-voltage connections: 35-5 and 35-6 (safety under pan), 35-3 and 35-4 (humidifier make-up valve), and 8-5 and 8-7 (high water alarm).
 - c. Disconnect 35-3 and 35-4 from the control board.
 - d. Pull the conduit and wires into the unit's blower and coil assembly section.
12. Condensate Pump—Optional Component
 - a. Disconnect the condensate pump's high-voltage wiring harness.
 - b. Remove the low-volt wires from terminal strips #24 and #55.
 - c. Pull the conduit and wires into the unit's blower and coil assembly section.
13. Vertiv™ Liebert® GLYCOOL/Dual-Cool—Optional Component
 - a. On units with an actuator, unplug the valve actuator harness at the actuator and pull the wire harness into the electric box.
 - b. Disconnect the glycol sensor from the control board and pull it into the unit's blower and coil assembly section.
14. Disconnect the air sail switch wires and pull them into the electric box.
15. Smoke Detector—Optional Component
 - a. Remove the smoke detector cover.
 - b. Remove the plug connector from the smoke detector and pull it into electric box.
 - c. Remove the wires from terminal strips #91, 92, 93 and route them into the smoke detector box.
 - d. Remove the sensing tube from top of the smoke detector.

NOTE: The wand and tube will remain attached to filter and electric box assembly.

16. Close the electric box cover and the accent panel.
17. Remove the pull bar that supports the accent panel from the left end of unit, otherwise it will fall out when the compressor section is removed.

18. Evacuate and recover all refrigerant from the unit.

Air-cooled units are shipped with an inert-gas holding charge. Water, glycol and Vertiv™ Liebert® GLYCOOL units are factory-charged with refrigerant. Refer to [Piping and Refrigerant Requirements](#) on page 31, for piping guidelines and to the ASHRAE Refrigeration Handbook for general, good-practice refrigeration piping.

NOTICE

Risk of compressor oil contamination with moisture. Can cause equipment damage.

We recommend front-seating the compressor service valves. Front-seating the valves keeps the inert gas or refrigerant charge in the compressor and prevents moisture from contaminating the compressor oil. This is particularly important with units using R-407C refrigerant.

19. Cut the insulation and pull it back from the piping.
20. Cut the refrigerant piping with a tubing cutter; if there is no Schrader fitting, let the inert gas bleed out before cutting all the way through the pipe.

NOTE: We do not recommend unsweating refrigerant connections.

21. Un-sweat or cut all copper water pipes that interconnect unit sections.
22. Immediately cap and seal all piping that has been cut, including the suction and liquid lines, as well as the fluid piping on Liebert® GLYCOOL and dual-cool units.

B.3 Remove the Compressor Assembly

1. Secure the compressor wire harness to the compressor assembly.
2. Remove the 10 thread-cutting bolts holding the compressor section assembly to the filter and electric box assembly and the blower and coil assembly.

There are five bolts in the front, four in the back and one on the top at the middle of the unit.

- a. Begin removing bolts at the bottom of the unit and progress toward the top. Use this method for the front and back bolts.
- b. Stabilize the compressor section before removing the top, middle bolt.

NOTICE

Risk of oil loss or displacement. Can cause compressor damage.

The compressor section is top-heavy and has a small base. It must remain upright. Do not lay the compressor section on its side during or after removing it from the unit. Do not remove shipping blocks from Semi-hermetic compressors until the unit is fully reassembled and ready for installation.

NOTE: We recommend using piano jacks when moving this section.

B.4 Remove the Filter and Electric Box Assembly

1. Using a stepladder to reach the top of the unit, remove the filter support plate; it is attached to the filter and electric box assembly with two screws, one on each end.
2. Remove tags from the Schrader fittings on top of the coil headers. Retain the tags for replacement during reassembly.
3. Remove 16 screws, (8) on each side, from the evaporator top cover plate to coil assembly. Coil top blocker will remain with top section for rigidity.

4. Remove coil access plates from the left side of the unit.
5. Remove the four thread-cutting bolts securing the filter and electric box assembly to the blower and coil assembly. There are two on the left and two on the right.
6. Separate the unit sections with caution.

NOTICE

Risk of improper handling.

- The filter and electric box section should be moved forward and set on the floor.
 - Make sure to lift the coil plate over the Schrader fittings on the headers. We recommend using four people to remove this section. Special care is required when moving this section because the legs are not designed to withstand strong shocks.
 - The blower and coil assembly must remain upright. The coil is not secured to the blower and coil assembly.
 - Secure the coil to the bottom section with straps or a similar method before moving the section.
7. Move each section of the unit to the installation location.

B.5 Reassembly—Downflow Units

1. Replace the top section.
Make sure to clear the Schrader valves on the coil header.
2. Reconnect the filter and electric box assembly to the blower and coil assembly using thread-cutting bolts.
Torque the bolts to 225 in-lb. (25 Nm)
3. Reattach the evaporator top cover plate; there are eight screws on each side.
4. Reattach the filter support plate to the filter and electric box assembly; there is one screw on each side.
5. Reattach the tags to the Schrader fittings on top of the coil headers.
6. Replace the compressor section.
Insert all compressor thread-cutting bolts before tightening any of the bolts.
7. Reinstall the pull bar to support the accent panel.
8. Reattach the low-voltage plugs in the compressor section.
9. Reconnect the wiring for the compressor, fan motor, reheat, humidifier, condensate pump, smoke detector and air sail switch.
10. Reattach the sensing tube to the top of the smoke detector.
11. On Vertiv™ Liebert® GLYCOOL and dual-cool units, reattach the plug connection at the actuator and reroute the sensor wire back through the electric box and onto the control board.

Reconnecting Piping, Charging and Replacing Panels

1. Piping must be reassembled in accordance with local codes.
2. Move insulation and plastic bushings away from the brazing area.
3. Wrap piping with wet cloths. Use copper fittings where required.
4. Refer to [Piping and Refrigerant Requirements](#) on page 31, for piping guidelines and to the ASHRAE Refrigeration Handbook for general, good-practice refrigeration piping.
5. Open the service valves on the compressor.
6. Reinsert the plastic bushings.
7. Charge the unit with refrigerant; see the unit's nameplate for the proper charge.
8. Reinstall the galvanized panels on the left side of the coil.

9. Replace the filters.
10. Replace the panels.

B.6 Reassembly Checklist

1. Thread-cutting bolts reconnected and torqued to 225 in-lb. (25 Nm)
2. Top cover plate attached to coil
3. Filter plate attached
4. High-voltage wires connected to proper contactors:
 - a. Compressor
 - b. Fan motor
 - c. Reheat, if applicable
 - d. Humidifier, if applicable
 - e. Condensate pump, if applicable
5. Low-voltage wires connected
 - a. Actuator
 - b. Terminal strip
 - c. Plug connections
 - d. Smoke detector, if applicable
6. Coil access plates on right and left replaced
7. Water lines brazed
8. Suction and liquid refrigerant lines brazed
9. Vacuum pulled and unit checked for leaks
10. Unit recharged
11. Filters replaced
12. Panels replaced
13. Piping systems pressure-checked for leaks

B.7 Disassembly—Upflow Units

1. Remove the unit from its skid.
2. Remove all panels except top front accent.
3. Remove all filters on front return units. This allows easier access to items located in the filter and coil assembly.
4. All wires are hot stamped and all circuit board connectors are lettered for easy replacement. Cable ties will need to be cut and replaced as necessary. Reference unit wiring schematic on dead-front panel for details.
5. Label the three quick connect plugs from the compressor compartment, and disconnect them.
6. Disconnect compressor wire harness, including crankcase heater wires, if applicable, from contactor in electric box. Pull conduit and wires into compressor compartment.
7. **Reheat (optional component):** Disconnect reheat wire harness from bottom of contactor in electric box. Unplug low-voltage quick connect for reheat safety wires. Pull conduit and wires into filter and coil assembly section of unit.

8. Humidifier (optional component):
 - a. Disconnect the humidifier wire harness from the bottom of the contactor in the electric box.

For infrared humidifiers: Remove the quick-connect plugs from these low-voltage connections: 35-5 and 35-6 (safety under pan), 35-3 and 35-4 (humidifier make-up valve) and 8-5 and 8-7 (high water alarm).
 - b. Disconnect 35-3 and 35-4 from the control board.
 - c. Pull the conduit and wires into the unit's filter and coil assembly section.
9. **Condensate pump (optional component):** Disconnect condensate pump high-voltage wire harness. Remove low volt wires from terminal strip #24 and #55. Pull conduit and wires into filter and coil assembly section of unit.
10. Vertiv™ Liebert® **GLYCOOL/Dual-Cool (optional component):** On units with actuator, unplug valve actuator harness at actuator and pull wire harness into electric box. Disconnect glycol sensor from control board and pull into filter and coil assembly section of unit.
11. **Smoke detector (optional component):** For units with smoke detector, remove cover on smoke detector. Remove plug connector from smoke detector and pull into electric box. Remove wires from terminal strip #91, 92, 93 and route the wires to the smoke detector box. Remove the sensing tube from the bottom of the plastic elbow.
12. **Filter Clog Switch:** Disconnect both tubes from the filter clog switch. Pull both of the tubes into the electric box.
13. Close the electric box cover and the accent panel.
14. Remove the pull bar that supports the accent panel from left end of unit, otherwise it will fall out when the compressor section is removed.
15. Evacuate and recover all refrigerant from the unit.

Air-cooled units contain an inert-gas holding charge. Water, glycol and GLYCOOL units are factory charged with refrigerant. Refer to [Piping and Refrigerant Requirements](#) on page 31, for piping guidelines and to the ASHRAE Refrigeration Handbook for general good practice refrigeration piping.

NOTICE

Risk of compressor oil contamination with moisture. Can cause equipment damage.

We recommend front-seating the compressor service valves. Front-seating the valves keeps the inert gas or refrigerant charge in the compressor and prevents moisture from contaminating the compressor oil. This is particularly important with units using R-407C refrigerant.

16. Cut and pull back insulation from piping.
17. Cut the refrigerant piping with a tubing cutter; if there is no Schrader fitting, let the inert gas bleed out before cutting all the way through the pipe.

NOTE: We do not recommend unswearing refrigerant connections.

18. Un-sweat or cut all copper water pipes that interconnect unit sections.
19. Immediately cap off and seal all piping that has been cut, including the suction and liquid lines, the humidifier supply line and the condensate discharge line (if applicable), as well as fluid piping on GLYCOOL and dual-cool units.

B.8 Remove the Compressor Assembly

1. Secure the compressor wire harness to the compressor assembly.
2. Remove the 10 thread-cutting bolts holding the compressor section assembly to the filter and electric box assembly and the blower and coil assembly.

There are five bolts in the front, four in the back and one on the top at the middle of the unit.

- a. Begin removing bolts at the bottom of the unit and progress toward the top. Use this method for the front and back bolts.
- b. Stabilize the compressor section before removing the top, middle bolt.

NOTICE

Risk of oil loss or displacement. Can cause compressor damage.

The compressor section is top-heavy and has a small base. It must remain upright. Do not lay the compressor section on its side during or after removing it from the unit. Do not remove shipping blocks from Semi-hermetic compressors until the unit is fully reassembled and ready for installation.

NOTE: We recommend using piano jacks when moving this section.

B.9 Remove Blower and Electric Box Assembly

1. Remove the motor access plate from right end of unit.
This will provide a place to grasp the blower and electric box assembly and move it.
Remove the coil access plates on the left side of the unit for clearance when brazing the suction and discharge lines.
2. Remove the thread-cutting bolts holding the unit sections together; there are four on the left and four on the right.
3. Separate the unit sections with caution.

NOTICE

Risk of improper handling. Can cause damage to the unit.

- The blower and electric box assembly should be moved forward and set on the floor.
 - We recommend using four people to remove this section.
 - The motor end will be significantly heavier than the other end.
 - The filter and coil assembly must remain upright. The coil is not secured to the filter and coil assembly.
 - Secure the coil to the bottom section with straps or a similar means before moving the section.
4. Move each section of the unit to the installation location.

B.10 Reassembly—Upflow Unit

1. Reattach the top section using thread-cutting bolts; there are four on each side.
Torque the bolts to 225 in-lb. (25 Nm).
2. Reinstall the motor access plate.
Do not replace the left end coil access plates until brazing is finished.
3. Reattach the compressor section. Insert all compressor thread-cutting bolts before tightening them all down.
4. Reinstall the pull bar to support the accent panel.

5. Reinstall the low-voltage plugs in the compressor section.
6. Rewire the compressor, reheat, humidifier, condensate pump and smoke detector, if applicable.
7. Reattach the sensing tube to the blower inlet.
8. Reattach the plug connection at the actuator and reroute the sensor back through electric box and onto control board, on Vertiv™ Liebert® GLYCOOL and dual-cool units.
9. Piping must be reassembled in accordance with local codes.
10. Move the insulation and plastic bushings away from the brazing area.
11. Wrap the piping with wet cloths. Use copper fittings where required.
12. Refer to [Piping and Refrigerant Requirements](#) on page 31, for piping guidelines and to the ASHRAE Refrigeration Handbook for general, good-practice refrigeration piping.
13. Open service valves on compressor.
14. Reinsert plastic bushings.
15. Charge the unit with refrigerant; see the unit's nameplate for the proper charge.
16. Replace the galvanized panels on the left side of the coil.
17. Replace the filters.
18. Replace the panels.

B.11 Reassembly Checklist—Upflow Unit

1. Thread-cutting bolts reconnected at a torque specification of 225 in-lb. (25 Nm).
2. High-voltage wires connected to proper contactors:
 - a. compressor
 - b. reheat, if applicable
 - c. humidifier, if applicable
 - d. condensate pump, if applicable
3. Low-voltage wires connected:
 - a. actuator
 - b. terminal strip
 - c. plug connections
 - d. smoke detector, if applicable
4. Coil access plates on left side replaced
5. Motor access plate on right side replaced
6. Water lines brazed
7. Suction and liquid refrigerant lines brazed
8. Unit recharged
9. Filters replaced
10. Panels replaced
11. Piping systems pressure-checked for leaks

This page intentionally left blank

Appendix C: Submittal Drawings

Table C.1 below, groups the drawings by topic/application.

Table C.1 Submittal Drawings Contents

Document Number	Title
Component Locations	
DPN003706	Component Location, Downflow Models
DPN003707	Component Location, Upflow Models
Dimension Planning Drawings	
DPN003643	Cabinet Dimensional Data, 35 to 105 kW (10 to 30 Tons) All Blower Types
DPN003681	Cabinet Dimensional Data Upflow 35-105kW (10-30 Tons) Models with EC Fans
DPN003646	Cabinet Dimensional Data Upflow 35 to 105 kW (10-30 Tons) with Forward Curved Blowers
DPN003240	Floor Stand Dimensional Data 35kW - 42kW (10-12 Tons) with EC Fans
DPN003173	Floor Stand Dimensional Data 53kW - 77 kW (15-22 Tons) with EC Fans
DPN003174	Floor Stand Dimensional Data 105 kW (30 Tons) Models with EC Fans
DPN003134	Floor Stand and Floor Planning Dimensional Data Upflow 35-42 kW (10-12 Tons) Models with Forward Curved Blowers
DPN003141	Floor Stand and Floor Planning Dimensional Data Upflow 53-77 kW (15-22 Tons) Models with Forward Curved Blowers
DPN003149	Floor Stand and Floor Planning Dimensional Data Upflow 105kW (30 Tons) Models with Forward Curved Blowers
DPN001120	Blower Outlet and Deck Dimensional Data Upflow 35-42 kW (10-12 Tons) with Forward Curved Blowers
DPN001191	Blower Outlet and Deck Dimensional Data Upflow 53-77kW (15-22) Tons with Forward Curved Blowers
DPN001192	Blower Outlet and Deck Dimensional Data Upflow 105kW (30 Tons) with Forward Curved Blowers
DPN001196	Rear Return Filter Box Dimensional Data Upflow 35-105kW (10-30 Tons) All Compressor Models with Forward Curved Blowers
DPN003974	Rear Return Filter Box Dimensional Data Upflow 35-105kW (10-30 Tons) with EC Fans All Compressor Models
DPN003164	Upflow Plenum Dimensional Data 35kW-105kW (10-30 Tons) Models with Forward Curved Blowers
DPN003458	Plenum Dimensional Data Upflow 35-42kW (10-12 Tons) Models with EC Fans
DPN003453	Plenum Dimensional Data Upflow 53-77kW (15-22 Tons) with EC Fans
DPN003459	Plenum Dimensional Data Upflow 105kW (30 Tons) Models with EC Fans
Piping General Arrangement	
DPN003954	Air Cooled Piping Schematic Condenser Above Indoor Unit
DPN003730	Piping Schematic with Vertiv™ Liebert® MC Condenser Air Cooled Scroll or Digital Scroll Compressor
DPN000896	Piping Schematic Water/Glycol Scroll Compressor Models
DPN001430	Piping Schematic Water Glycol Digital Scroll Compressor Models

Table C.1 Submittal Drawings Contents (continued)

Document Number	Title
DPN000895	Piping Schematic Water/Glycol 77kW-105kW Semi-Hermetic Compressor Models
DPN000897	Piping Schematic GLYCOOL 77kW - 105kW Semi-Hermetic Compressor Models
DPN001432	Piping Schematic GLYCOOL Digital Scroll Compressor Models
DPN000805	Optional Piping Schematic Vertiv™ Liebert® Econ-o-Coil Models
DPN004216	Piping Schematic with Liebert® MC Air Cooled DS077-105kW Semi-Hermetic Compressor Models
Piping Connection Drawings	
DPN003239	Primary Connection Locations Downflow Air Cooled 35-42kW (10-12 Tons) Scroll or Digital Scroll Compressor Models
DPN002182	Primary Connection Locations Downflow Air Cooled 53-77kW Scroll or Digital Scroll Compressor Models with EC Fans
DPN002179	Primary Connections Downflow Air Cooled 77kW (22 Tons) Semi-Hermetic Compressor Models
DPN002154	Primary Connection Locations Downflow Air Cooled 105kW (30 Tons) All Compressor Models
DPN003530	Primary Connection Locations Downflow Water/Glycol/GLYCOOL 35-42kW (10-12 Tons) All Compressor Models
DPN002183	Primary Connection Locations Downflow Water/Glycol/GLYCOOL 53-77kW (15-22 Tons) All Compressor Models
DPN002153	Primary Connection Locations Downflow Water/Glycol/GLYCOOL (30 Tons) All Compressor Models
DPN002740	Primary Connection Locations Upflow Air Cooled 35-42kW (10-12 Tons) Scroll or Digital Scroll Compressor Models with EC Fans
DPN002742	Primary Connection Locations Upflow Air Cooled 77kW (22 Tons) Semi-Hermetic Compressor Models with EC Fans
DPN002743	Primary Connection Locations Upflow Air Cooled 53-77kW (15-22 Tons) Scroll or Digital Scroll Compressor Models
DPN002745	Primary Connection Locations Upflow Air Cooled 105kW (30 Tons) All Compressor Models
DPN002741	Primary Connection Locations Upflow Water/Glycol/GLYCOOL 35-42kW (10-12 Tons) Scroll and Digital Scroll Compressor Models with EC Fans
DPN002744	Primary Connection Locations Upflow Water/Glycol/GLYCOOL 53-77kW (15-22 Tons) All Compressor Models with EC Fans
DPN002746	Primary Connection Locations Upflow Water/Glycol/GLYCOOL 105kW (30 Tons) All Compressor Models
DPN001119	Primary Connection Locations Upflow Air Cooled 35-42kW (10-12 Tons) Scroll or Digital Scroll Compressor Models with Forward Curved Blowers
DPN001212	Primary Connection Locations Upflow Air Cooled 77kW (22 Tons) Semi-Hermetic Compressor Models with Forward Curved Blowers
DPN001213	Primary Connection Locations Upflow Air Cooled 53-77kW 15-22 Tons Scroll or Digital Scroll Compressors
DPN001257	Primary Connection Locations Upflow Air Cooled 105kW (30 Tons) All Compressor Models
DPN001179	Primary Connection Locations Upflow Water/Glycol/GLYCOOL 35-42 kW (10-12 Tons) Scroll and Digital Scroll Compressor Models with Forward Curved Blower
DPN001214	Primary Connection Locations Upflow Water/Glycol/GLYCOOL 53-77kW (15-22 Tons) All Compressor Models with Forward Curved Blowers

Table C.1 Submittal Drawings Contents (continued)

Document Number	Title
DPN001258	Primary Connection Locations Upflow Water/Glycol/GLYCOOL 105kW (30 Tons) All Compressor Models
Electrical Field Connection Drawings	
DPN004352	Electrical Field Connection Description Upflow and Downflow Models
DPN003267	CANbus and Interlock Connections between Vertiv™ Liebert® DS and Vertiv™ Liebert® MC Condenser (Premium)
Disassembly Dimension Drawings	
DPN003647	Disassembly Dimensional Data Downflow 35-42 kW (10-12 Tons) Models with Scroll and Digital Scroll Compressors
DPN003648	Disassembly Dimensional Data Downflow 53-77kW (15-22 Tons) Models
DPN003649	Disassembly Dimensional Data Downflow 105kW (30 Tons) Models
DPN003650	Disassembly Dimensional Data Upflow 35-42kW (10-12 Tons) Models with Scroll and Digital Scroll Compressors
DPN003657	Disassembly Dimensional Data Upflow 53-77kW (15-22 Tons) Models
DPN003658	Disassembly Dimensional Data Upflow 105kW (30 Tons) Models

This page intentionally left blank

COMPONENT LOCATION DOWNFLOW MODELS

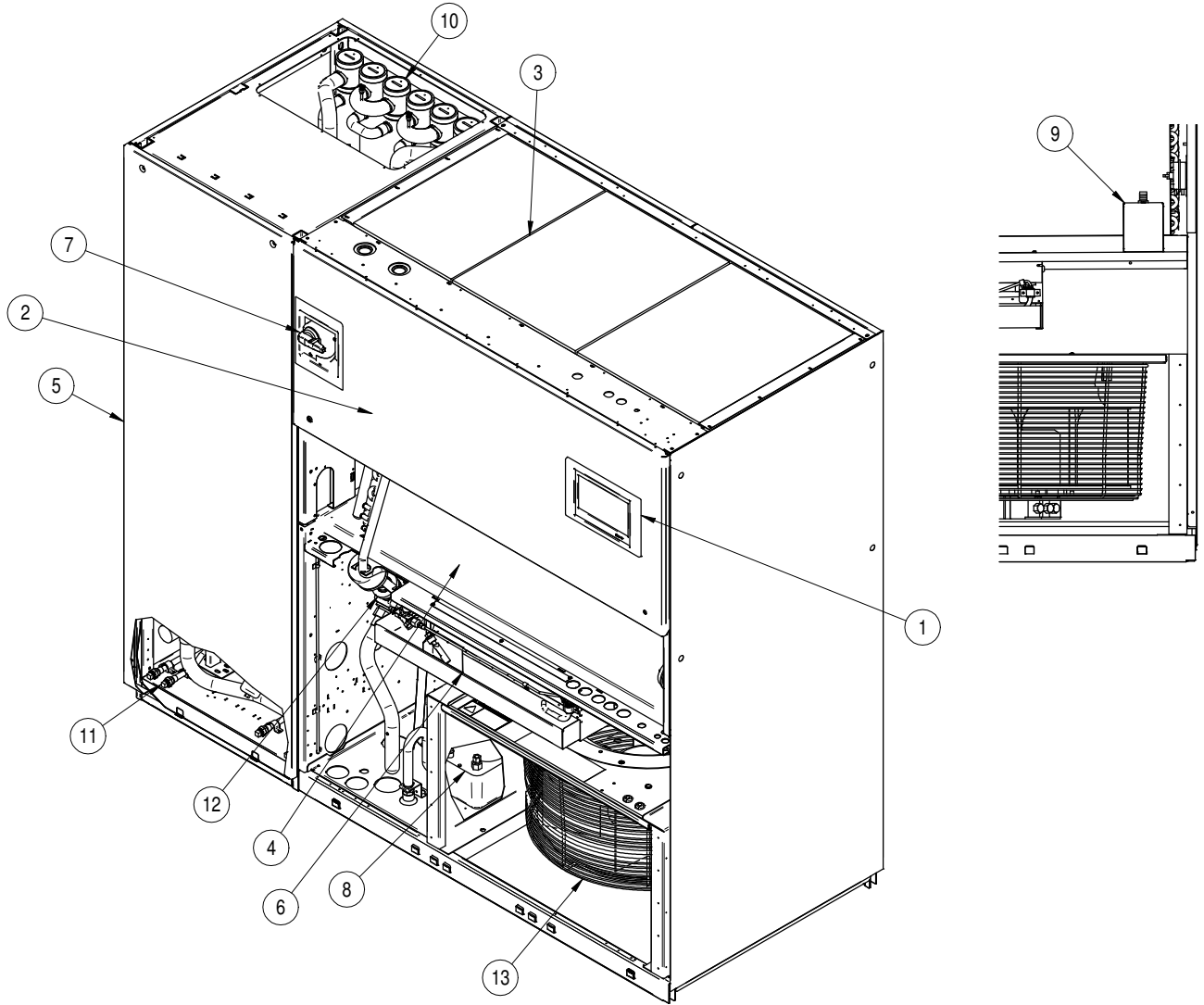

1.	Liebert® iCOM™ Control Display
2.	Electric Box
3.	Filters
4.	Evaporator Coil
5.	Compressor Section
6.	Infrared Humidifier (optional)
7.	Disconnect
8.	Condensate Pump (optional)
9.	Smoke Sensor (optional)
10.	Condenser Clean out Plugs (fluid cooled units only)
11.	Condenser Drain Plugs (fluid cooled units only)
12.	Liebert® Econ-o-Coil Valve (Glycol/Dual cooling)
13.	EC Fans

COMPONENT LOCATION UPFLOW 28-42kW (8-12 TONS) MODELS

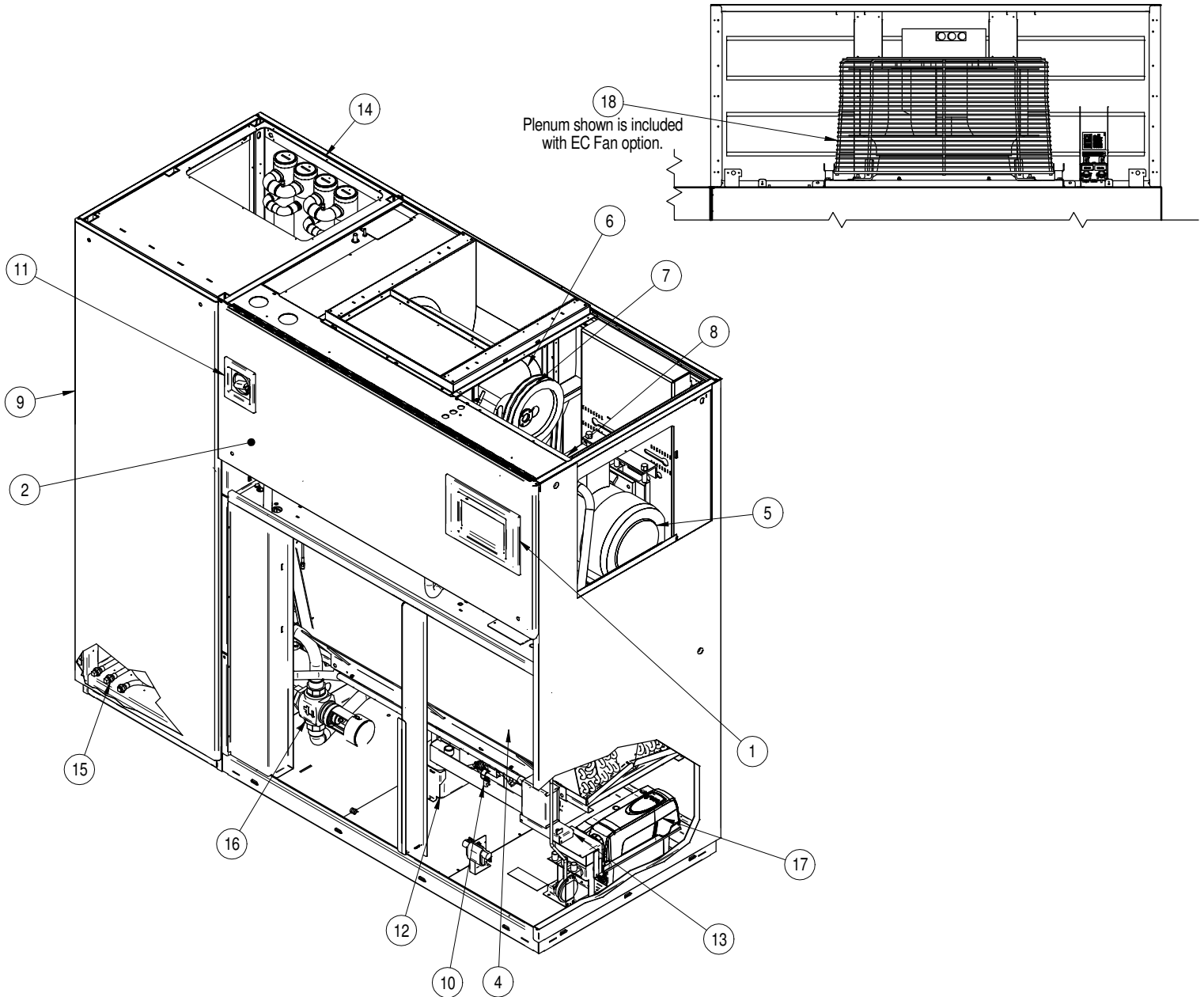

- | | |
|------------------------------------|--|
| 1. Liebert® iCOM™ Control Display | 9. Compressor Section |
| 2. Electric Box | 10. Infrared Humidifier (optional) |
| 3. Filters (not shown for clarity) | 11. Disconnect (optional) |
| 4. Evaporator Coil | 12. Condensate Pump (optional) |
| 5. Motor | 13. Smoke Sensor (optional) |
| 6. Blower | 14. Condenser Clean out Plugs (fluid cooled units only) |
| 7. Fan Pulley | 15. Condenser Drain Plugs (fluid cooled units only) |
| 8. Motor Sheave and Belts | 16. Liebert® Econ-o-Coil Valve (Glycool/Dual Cooling) |
| | 17. Variable Frequency Drive (optional on digital scroll units only) |
| | 18. EC Fans (optional) |

CABINET DIMENSIONAL DATA DOWNFLOW 35-105kW (10-30 TONS) MODELS

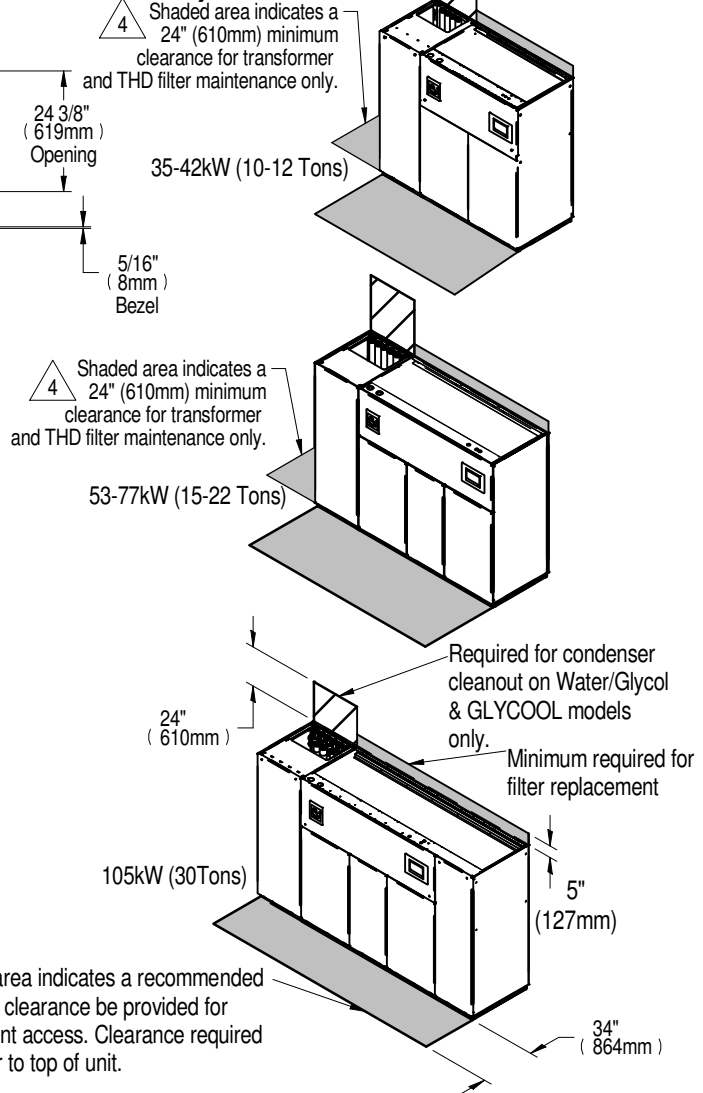
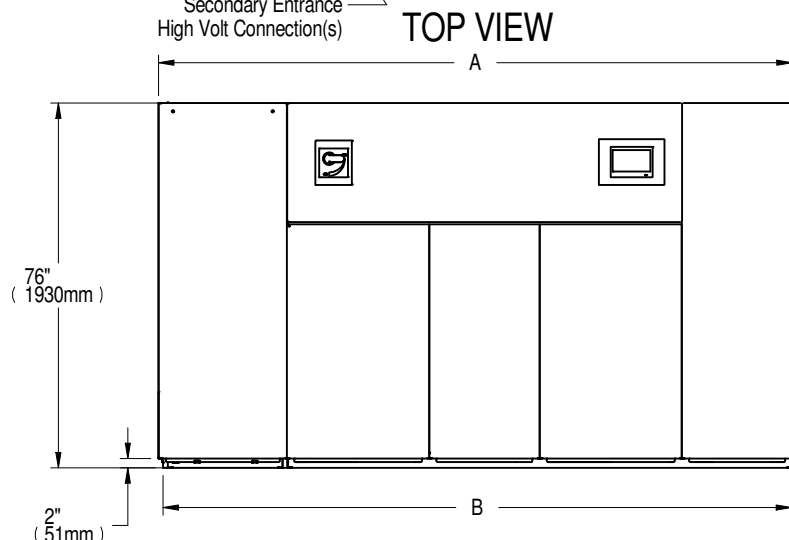
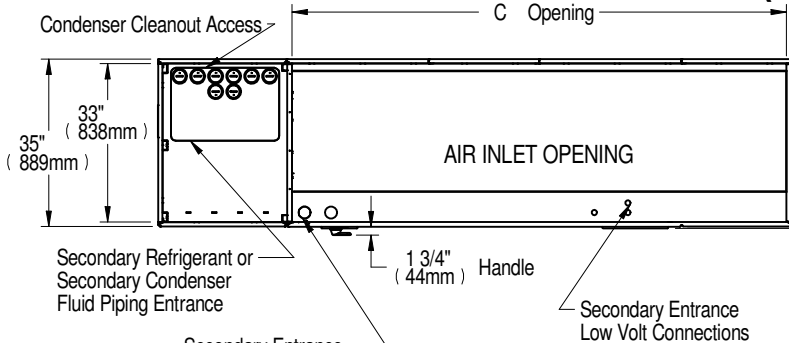

- Notes:
1. Filters are accessible through top of unit only.
 2. Downflow electrical connections can be made from top or bottom of unit
 3. All notes, references, and dimensions not in table are typical for all downflow models.

Shaded area indicates a recommended minimum clearance be provided for component access. Clearance required from floor to top of unit.

4. Unit power must be off when performing transformer and THD filter maintenance.

Model Number	Compressor Type	Cooling Type	A in. (mm)	B in. (mm)	C in. (mm)
35kW - 42kW	Scroll or Digital Scroll	Air Cooled & AirCooled w/ Dual Cool	73 (1854)	72 (1854)	56-7/8 (1445)
		Water/Glycol/GLYCOOL/Dual Cool	86 (2184)	85 (2184)	
53kW - 70kW	Scroll or Digital Scroll	Air Cooled & AirCooled w/ Dual Cool	98 (2489)	97 (2489)	80 (2032)
		Water/Glycol/GLYCOOL/Dual Cool	109 (2769)	108 (2743)	
77kW	Scroll	Air Cooled & AirCooled w/ Dual Cool	98 (2489)	97 (2489)	
	Semi-Hermetic	Air Cooled & AirCooled w/ Dual Cool	109 (2769)	108 (2743)	
105kW	Semi-Hermetic	Water/Glycol/GLYCOOL/Dual Cool			132 (3353)
		Air Cooled & AirCooled w/ Dual Cool	102-13/16 (2611)		
		Water/Glycol/GLYCOOL/Dual Cool			

CABINET DIMENSIONAL DATA
UPFLOW 35-105kW (10-30 TONS) MODELS W/ EC FANS

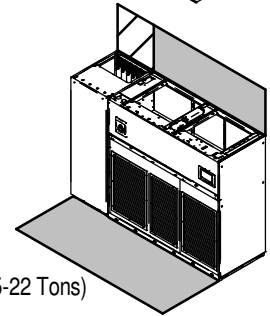
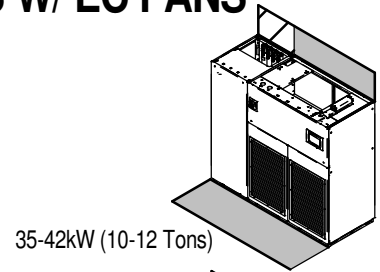
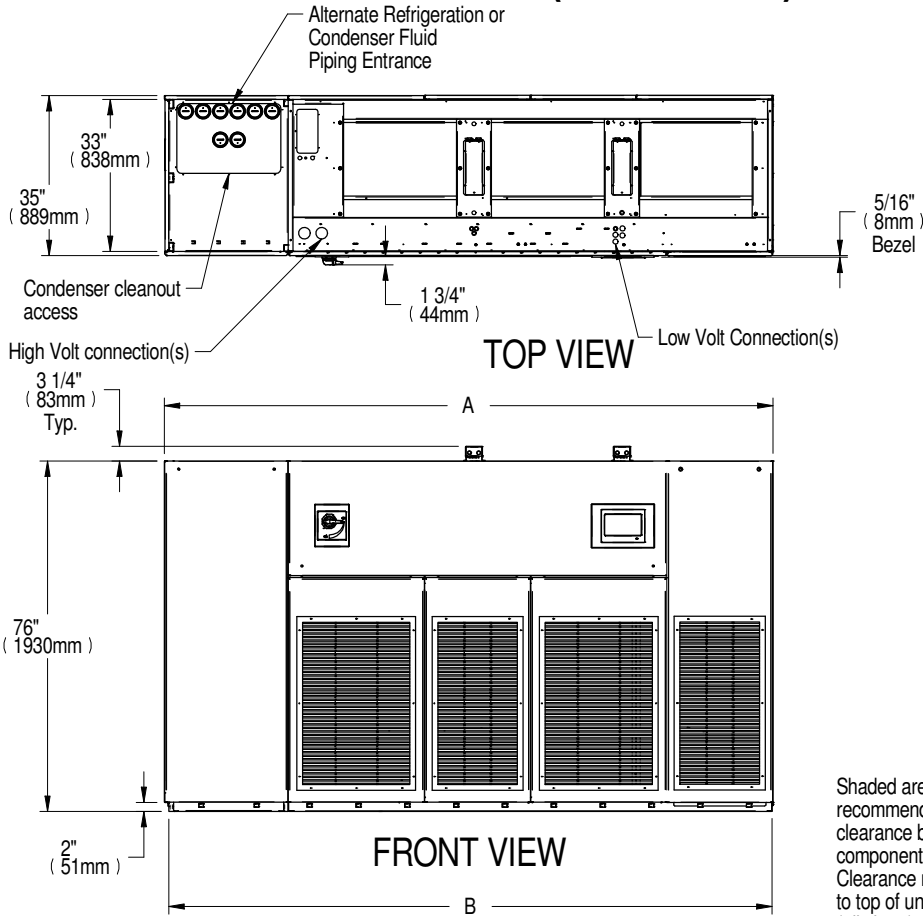

53-77kW (15-22 Tons)

Space required for EC Fan Plenum (shipped separately) dependent on height of plenum ordered (all views).

Required for Condenser cleanout on Water/Glycol & GLYCOOL models only (all views).

24" (610mm)

Shaded area indicates a recommended minimum clearance be provided for component access. Clearance required from floor to top of unit and plenum (all views).

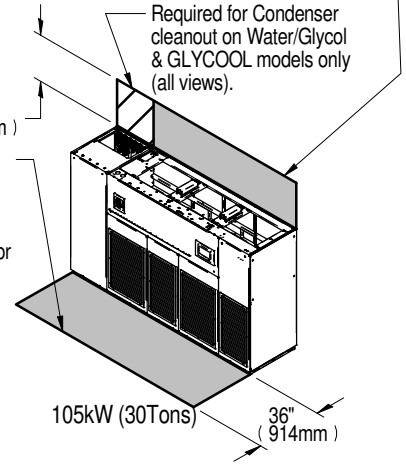

- Note:
1. Front air return unit shown. For rear return unit, in addition to front service area shown, also include 25" (635mm) on one side of unit for access to rear return filter box. See DPN003974.
 2. EC fans plenum is not shown. EC fans and plenum shipped separately. See DPN003458, DPN003453, & DPN003459 for unit dimensions with EC fans plenum mounted.
 3. All notes, references, and dimensions not included in table are typical on all Upflow EC Fan units.

Model Number	Compressor Type	Cooling Type	A in. (mm)	B in. (mm)
35kW - 42kW	Scroll or Digital Scroll	AirCooled/Air Cooled w/Dual Cool	73 (1854)	72 (1829)
		Water/Glycol/GLYCOOL/Dual Cool	86 (2184)	85 (2159)
53kW - 70kW	Scroll or Digital Scroll	AirCooled/Air Cooled w/Dual Cool	98 (2489)	97 (2464)
		Water/Glycol/GLYCOOL/Dual Cool	109 (2769)	108 (2743)
77kW	Scroll	AirCooled	98 (2489)	97 (2464)
	Semi-hermetic	AirCooled/Air Cooled w/Dual Cool	109 (2769)	108 (2743)
Water/Glycol/GLYCOOL/Dual Cool				
105kW	Scroll	AirCooled	132 (3353)	131 (3327)
	Semi-hermetic	AirCooled/Air Cooled w/Dual Cool		
			Water/Glycol/GLYCOOL/Dual Cool	

CABINET DIMENSIONAL DATA

UPFLOW 35-105kW (10-30 TONS) W/ FORWARD CURVED BLOWERS

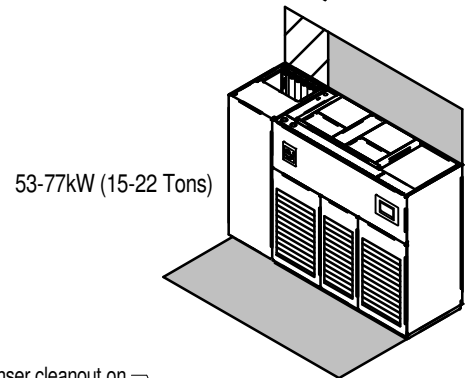
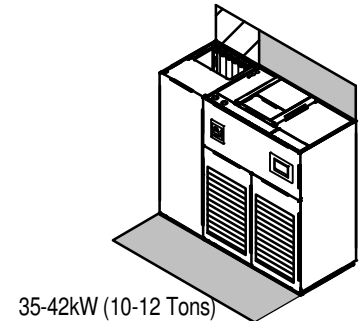
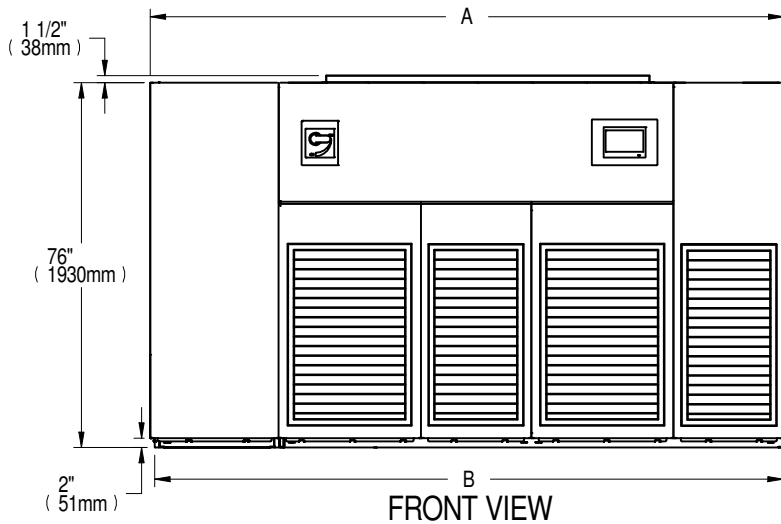
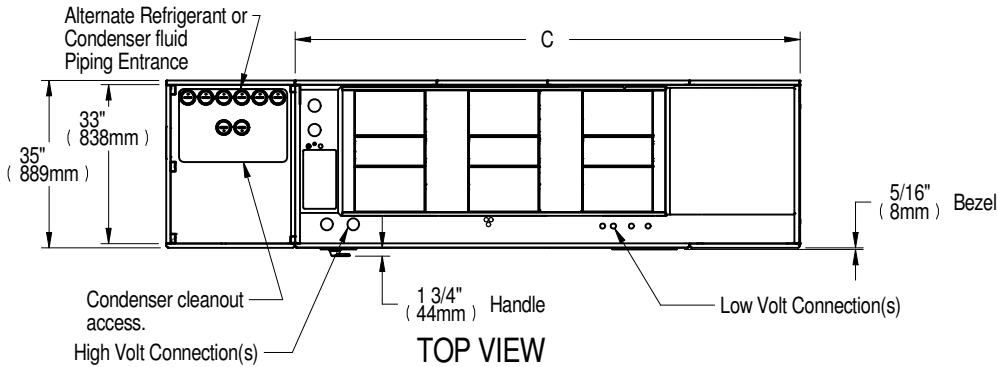

Required for condenser cleanout on Water/Glycol & GLYCOOL/Dual Cooled models only (all views).

Shaded area indicates a recommended minimum clearance be provided for component access. Clearance required from floor to top of unit and plenum (all views).

Minimum required for blower replacement (all views)

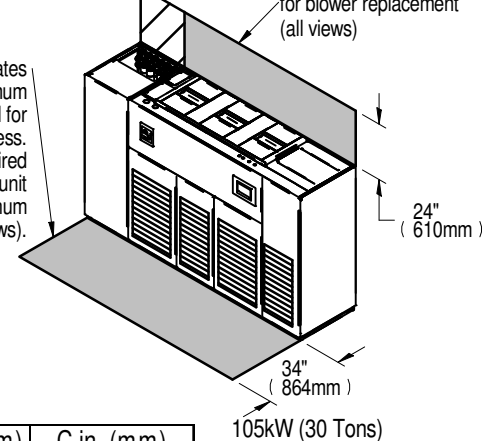

Notes:

1. Front air return unit shown. For rear return unit, in addition to front service area shown, also include 25" (635mm) on one side of unit for access to rear return filter box. See DPN001196.
2. All dimensions, references, and notes not in table are typical to all Upflow units with Forward Curved Fans.

3. Digital Scroll compressors not available on Air Cooled 42kW models.

Model Number	Compressor Type	Cooling Type	A in. (mm)	B in. (mm)	C in. (mm)
35kW - 42kW	Scroll or Digital Scroll 3	AirCooled/Air Cooled w/Dual Cool	73 (1854)	72 (1829)	59-1/4 (1504)
		Water/Glycol/GLYCOOL/Dual Cool	86 (2184)	85 (2159)	
53kW - 70kW	Scroll or Digital Scroll	AirCooled/Air Cooled w/Dual Cool	98 (2489)	97 (2464)	82-1/8 (2086)
		Water/Glycol/GLYCOOL/Dual Cool	109 (2769)	108 (2743)	
77kW	Scroll	AirCooled	98 (2489)	97 (2464)	
	Semi-hermetic	AirCooled/Air Cooled w/Dual Cool	109 (2769)	108 (2743)	
Water/Glycol/GLYCOOL/Dual Cool					
105kW	Scroll	AirCooled	132 (3353)	131 (3327)	
	Semi-hermetic	AirCooled/Air Cooled w/Dual Cool			
			Water/Glycol/GLYCOOL/Dual Cool		

FLOORSTAND DIMENSIONAL DATA
35kW - 42kW (10-12 TONS) W/ EC FANS

Notes:

1. This floorstand should be used when EC fans are intended to be lowered under a raised floor. 24-48" floorstands allow fan to be lowered under the raised floor.
2. Right side of paneled unit is flush with right side of floorstand. All other paneled sides overhang floorstand 1" (25mm).
3. The floorstand used with EC units is not symmetrical and its orientation to the Liebert® DS is critical for lowering the EC fans. Unless the floorstand is installed in the correct position, the blowers will not lower into the floor stand.

4. Jack and jack support are shipped loose and are intended to be placed into position under each fan and utilized to lower or raise that fan as needed for Downflow units.
5. Leveling feet are provided with $\pm 1-1/2"$ (38mm) adjustment from nominal height "E".
6. Applies to 36", 42", & 48" Floorstands.

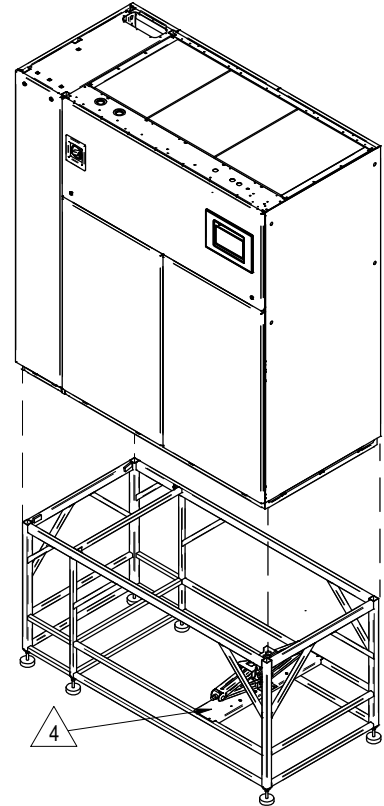
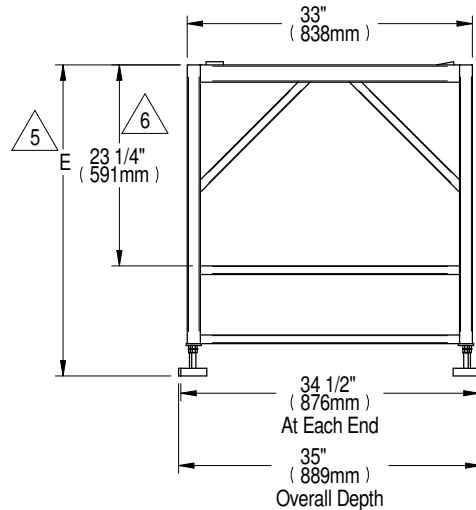
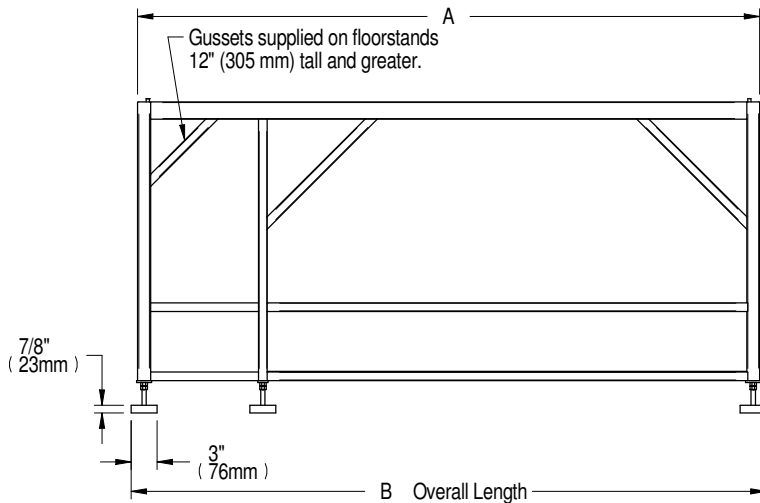
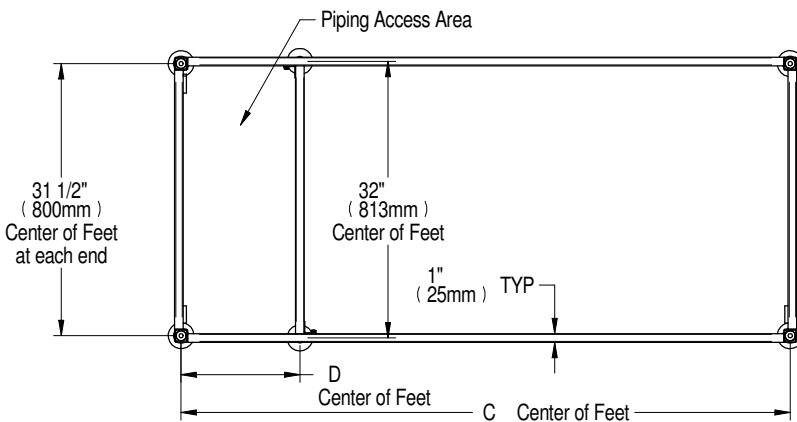

Model	Dimensional Data in. (mm)				Height in. (mm) 
	A	B	C	D	E
35kW - 42kW Water/Glycol/GLYCOOL Scroll & Digital Scroll Models	85 (2159)	86-1/2 (2197)	83-1/2 (2121)	26-3/4 (679)	24 (610)
35kW - 42kW Air-Cooled Scroll and Digital Scroll Models	72 (1829)	73-1/2 (1867)	70-1/2 (1791)	13-3/4 (349)	30 (762)
					36 (914)
					42 (1069)
					48 (1219)

FLOORSTAND DIMENSIONAL DATA
53kW-77kW (15-22 TONS) W/ EC FANS

Notes:

1. This floorstand should be used when EC fans are intended to be lowered under a raised floor. 24-48" floorstands allow fan to be lowered under raised floor.
2. Right side of paneled unit is flush with right side of floorstand. All other paneled sides overhang floorstand 1" (25mm).
3. The floorstand used with EC units is not symmetrical and its orientation to the Liebert® DS is critical for lowering the EC fans. Unless the floorstand is installed in the correct position, the blowers will not lower into the floor stand.
4. Jack and jack support are shipped loose and are intended to be placed into position under each fan and utilized to lower or raise that fan as needed for Downflow units.
5. Leveling feet are provided with ± 1-1/2" (38mm) adjustment from nominal height "F".
6. Applies to 36", 42" & 48" Floorstand.

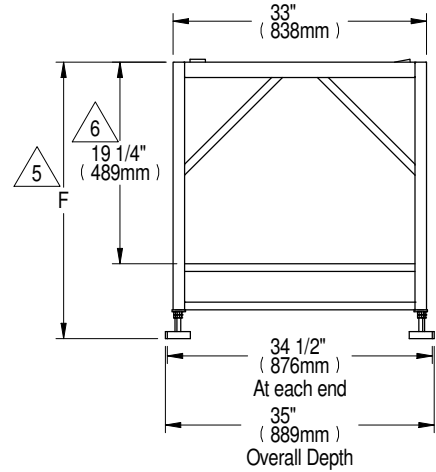
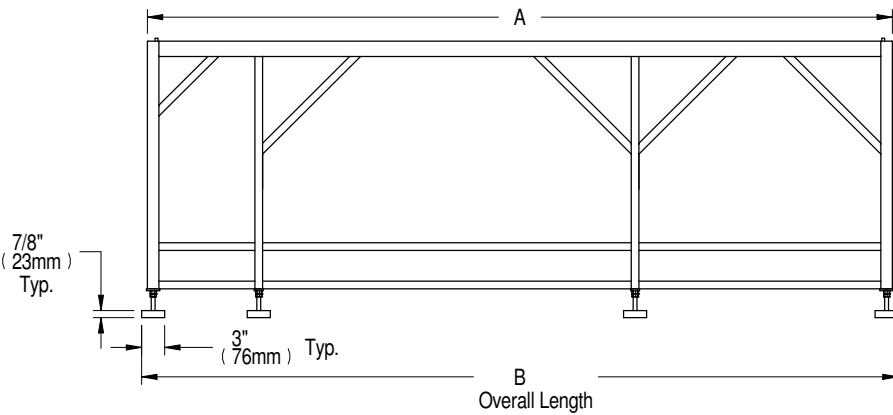
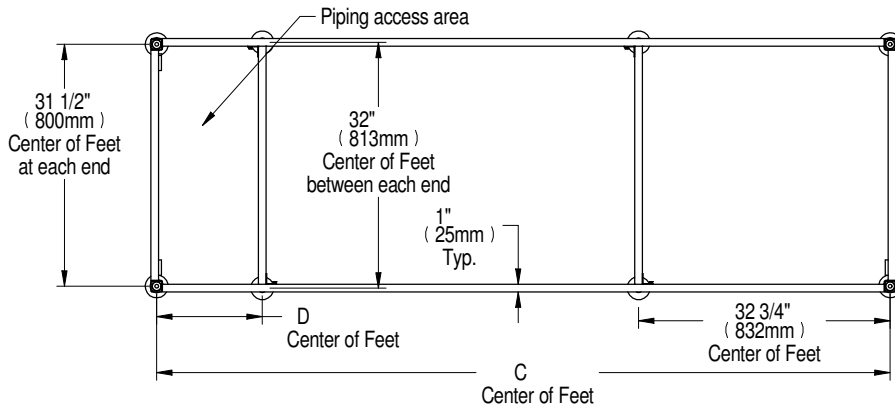
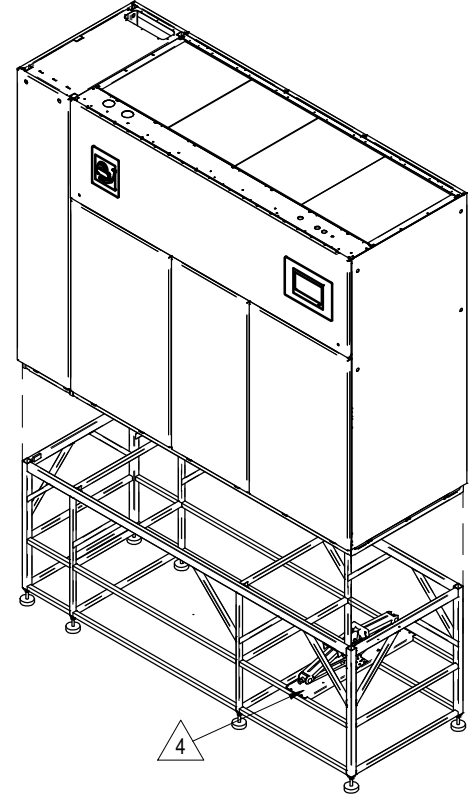

	Dimensional Data in (mm)			
	A	B	C	D
53kW - 70kW, Water/Glycol/GLYCOOL Scroll Models	108 (2743)	109-1/2 (2781)	106-1/2 (2705)	24-3/4 (629)
53kW - 70kW, Air-Cooled Scroll and Air-Cooled Digital Scroll Models	97 (2464)	98-1/2 (2502)	95-1/2 (2426)	13-3/4 (349)
77kW, All Semi-hermetic Models	108 (2743)	109-1/2 (2781)	106-1/2 (2705)	24-3/4 (629)
77kW, Air-Cooled Scroll Models	97 (2464)	98-1/2 (2502)	95-1/2 (2426)	13-3/4 (349)

Height in (mm)
F $\frac{F}{\Delta}$
24 (610)
30 (762)
36 (914)
42 (1067)
48 (1219)

FLOORSTAND DIMENSIONAL DATA 105kW (30 TONS) MODELS W/ EC FANS

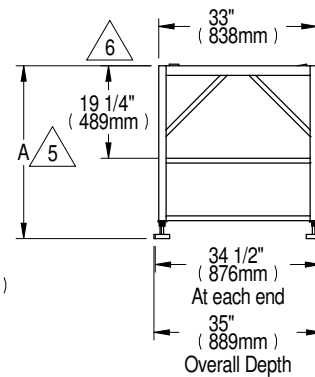
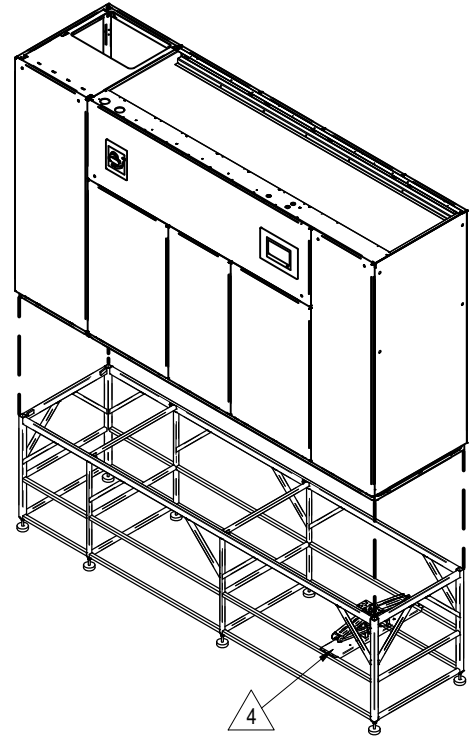
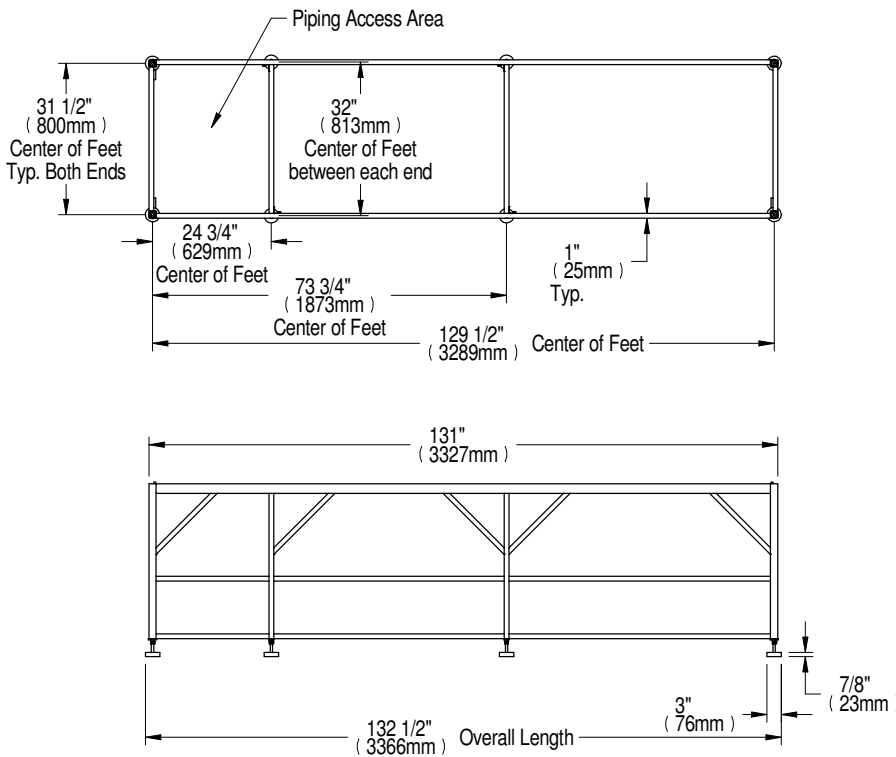

Notes:

1. This floorstand should be used when EC fans are intended to be lowered under a raised floor.
2. Right side of paneled unit is flush with right side of floorstand. All other paneled sides overhang floorstand 1" (25mm).
3. The floorstand used with EC units is not symmetrical and its orientation to the Liebert® DS is critical for lowering the EC fans. Unless the floorstand is installed in the correct position, the blowers will not lower into the floorstand.

4. Jack and jack support are shipped loose and are intended to be placed into position under each fan and utilized to lower or raise that fan as needed for Downflow units.

5. Leveling feet are provided with ± 1-1/2" (38mm) adjustment from nominal height "A".

6. Applies to 36", 42", & 48" Floorstands.

Height in (mm)
A <u>5</u>
24 (610)
30 (762)
36 (914)
42 (1067)
48 (1219)

**FLOORSTAND & FLOOR PLANNING DIMENSIONAL DATA
UPFLOW 35-42kW (10-12 TONS) MODELS W/ FORWARD CURVED BLOWERS**

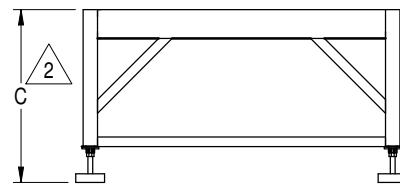
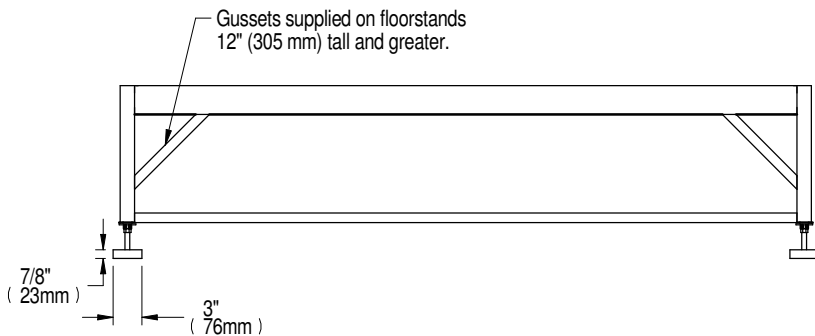
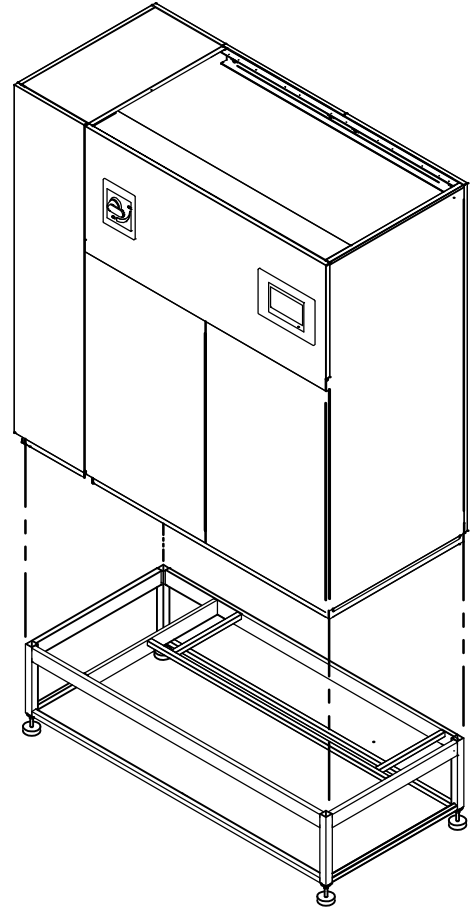
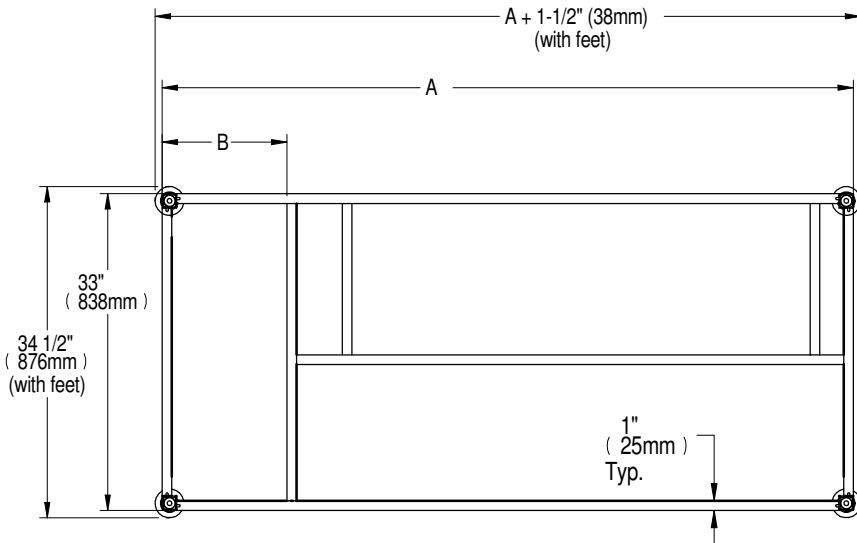

Height in (mm)
C/2
9 (229)
12 (305)
15 (381)
18 (457)
21 (533)
24 (610)

Dimensional Data in (mm)		
	A	B
Water/Glycol/GLYCOOL cooled Scroll & Digital Scroll Models	85 (2159)	26 (660)
Air-Cooled Scroll and Digital Scroll Models ³	72 (1829)	13 (330)

Notes:

1. Right side of paneled unit is flush with right side of floorstand. All other paneled sides overhang floorstand 1" (25mm).

2. Leveling feet are provided with ± 1-1/2" (38mm) adjustment from nominal height C.

3. Digital Scroll compressors not available on Air Cooled 42kW models.



VERTIV™

LIEBERT® DS

FLOORSTAND & FLOOR PLANNING DIMENSIONAL DATA UPFLOW 53-77kW (15-22 TONS) MODELS W/ FORWARD CURVED BLOWERS

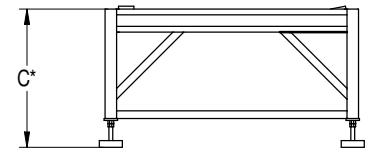
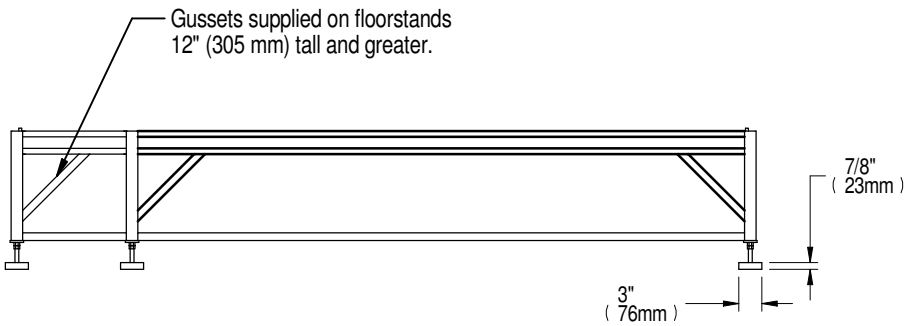
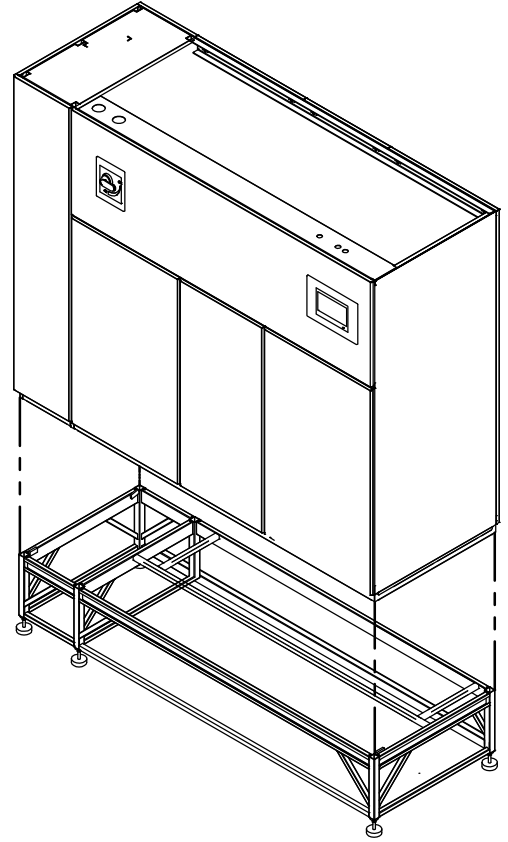
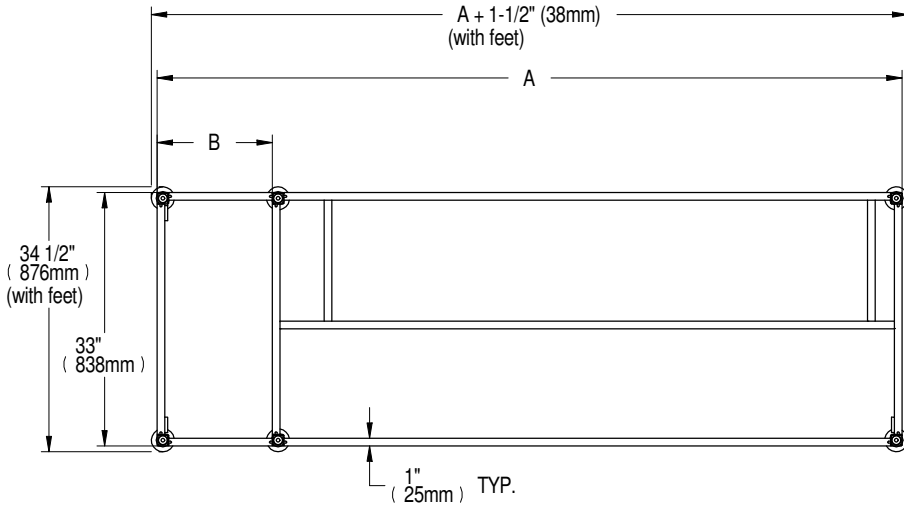

Dimensional Data in. (mm)		
	A	B
Air-Cooled Semi-Hermetic and all Water/Glycol/GLYCOOL Models ³	108 (2743)	26 (660)
Air-Cooled Scroll and Air-Cooled Digital Scroll Models	97 (2464)	15 (381)

Height in (mm)
C ²
9 (229)
12 (305)
15 (381)
18 (457)
21 (533)
24 (610)

Notes:

1. Right side of paneled unit is flush with right side of floorstand. All other paneled sides overhang floorstand 1" (25mm).

² Leveling feet are provided with ± 1-1/2" (38mm) adjustment from nominal height C.

³ Semi-Hermetic Compressor only available on 77kW models.



VERTIV™

LIEBERT® DS

FLOORSTAND & FLOOR PLANNING DIMENSIONAL DATA UPFLOW 105kW (30 TONS) MODELS W/ FORWARD CURVED BLOWERS

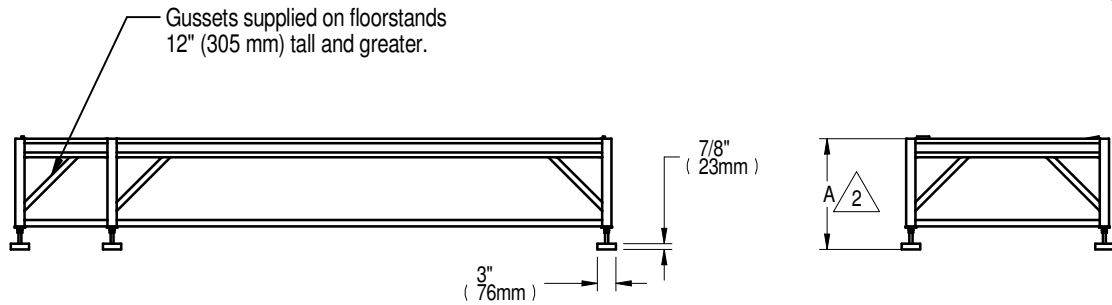
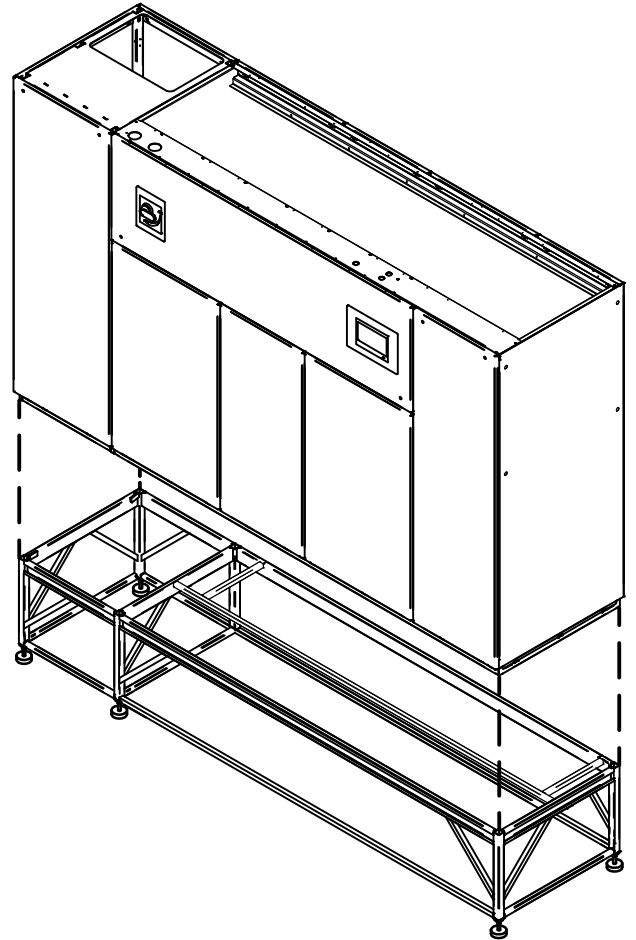
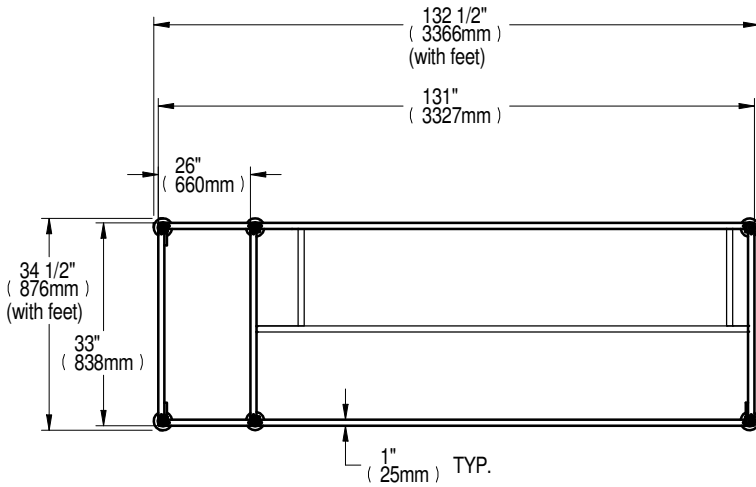

Height in. (mm)
A / 2
9 (229)
12 (305)
15 (381)
18 (457)
21 (533)
24 (610)

Notes:

1. Right side of paneled unit is flush with right side of floorstand. All other paneled sides overhang floorstand 1" (25mm).

2. Leveling feet are provided with ± 1-1/2" (38mm) adjustment from nominal height A.

**BLOWER OUTLET & DECK DIMENSIONAL DATA
UPFLOW 35-42kW (10-12 TONS) W/ FORWARD CURVED BLOWERS**

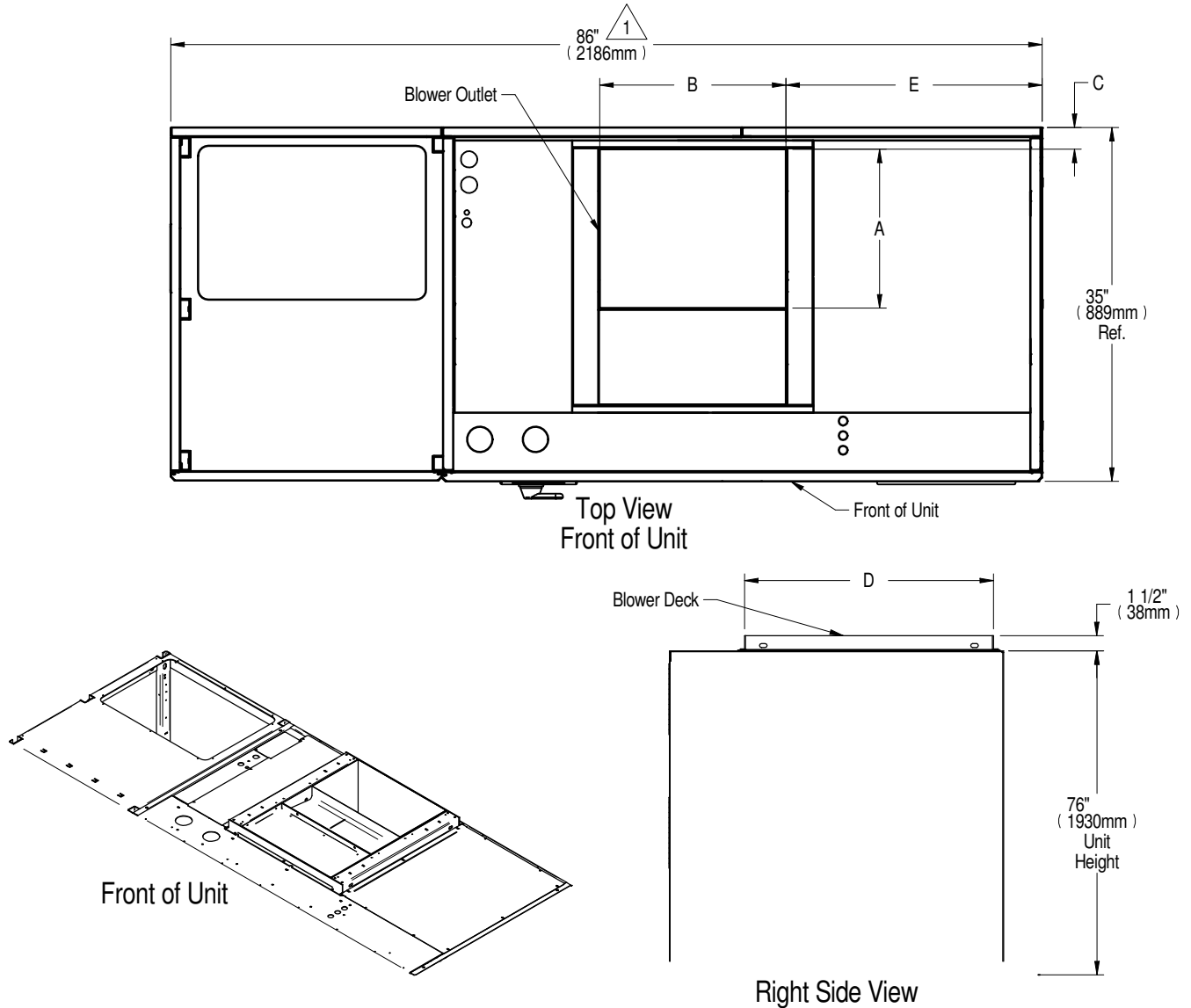

Notes:

1. Applies to units with Semi-Hermetic compressor section.
Dimension for units with Scroll type compressor section is 73" (1854mm).
2. Digital Scroll compressors not available on Air Cooled 42kW models.

BLOWER	SUPPLY	DIMENSIONAL DATA inches (mm)					
		A	B	C	D	E	
15 x 15	FRONT THROW	15-7/8 (404)	18-5/8 (472)	2-1/8 (54)	24-5/8 (625)	25-1/4 (641)	
	REAR THROW			11-5/8 (295)			
15 x 11	FRONT THROW		14-3/4 (375)	2-1/8 (54)			11-5/8 (295)
	REAR THROW						

BLOWER OUTLET & DECK DIMENSIONAL DATA UPFLOW 53-77kW (15-22 TONS) W/ FORWARD CURVED BLOWERS

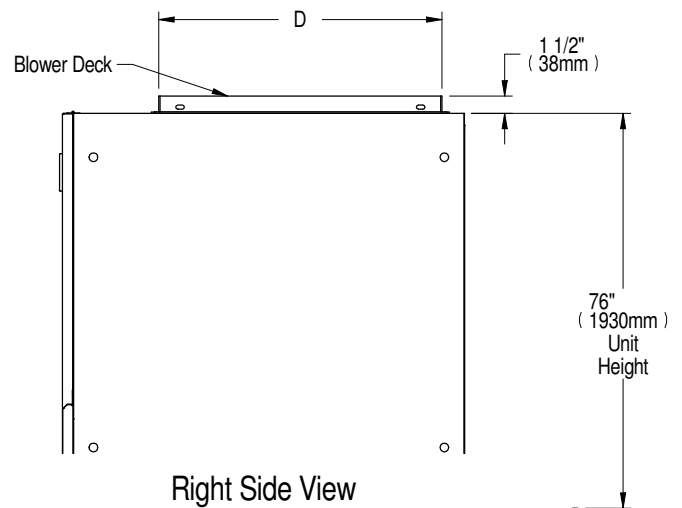
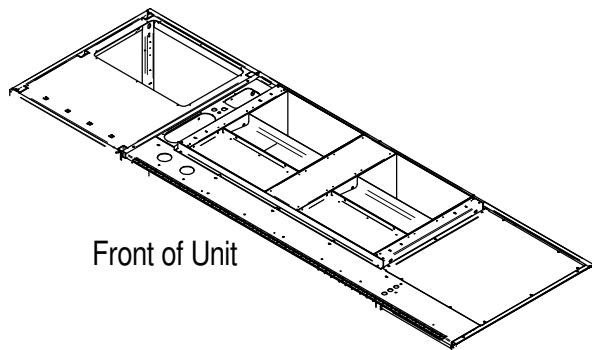
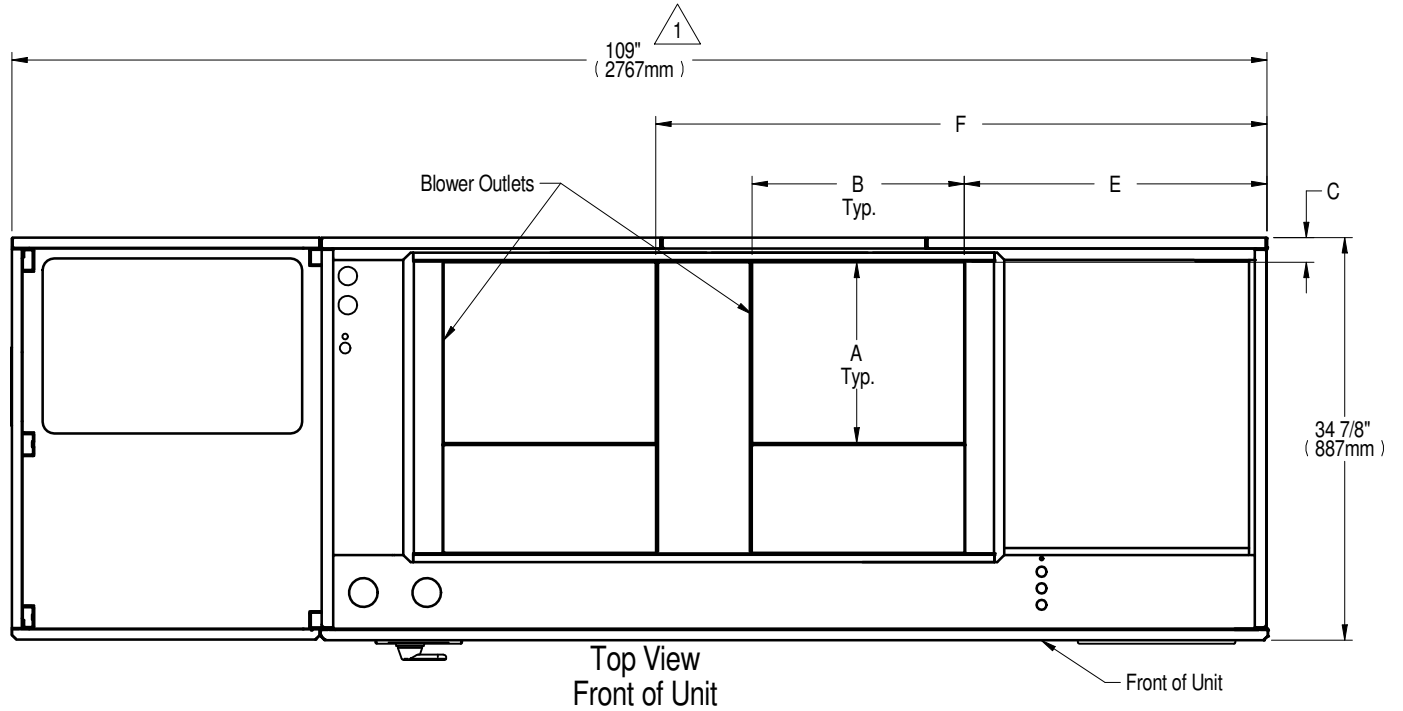

Notes:

1. Applies to units with Semi-Hermetic compressor section.
Dimension for units with Scroll type compressor section is 98" (2489mm).

MODELS	BLOWER	SUPPLY	DIMENSIONAL DATA inches (mm)					
			A	B	C	D	E	F
53-77kW (15-22 Tons)	15 x 15	FRONT THROW	15-7/8 (404)	18-5/8 (472)	2-1/8 (54)	24-5/8 (625)	27-7/8 (708)	54-1/2 (1384)
		REAR THROW			11-5/8 (295)			
	15 x 11	FRONT THROW		14-3/4 (375)	2-1/8 (54)		31-3/8 (797)	
		REAR THROW		11-5/8 (295)				

BLOWER OUTLET & DECK DIMENSIONAL DATA UPFLOW 105kW (30 TONS) W/ FORWARD CURVED BLOWERS

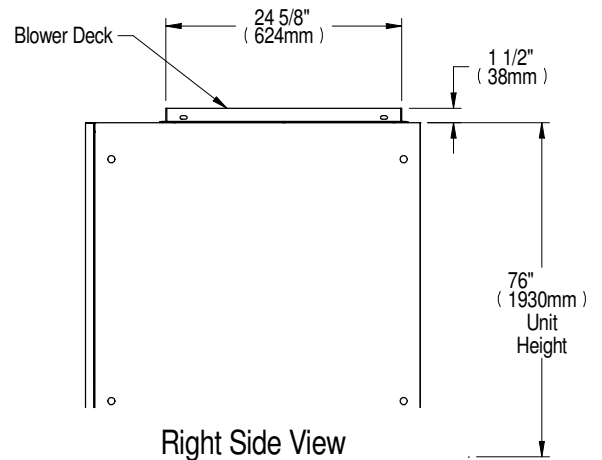
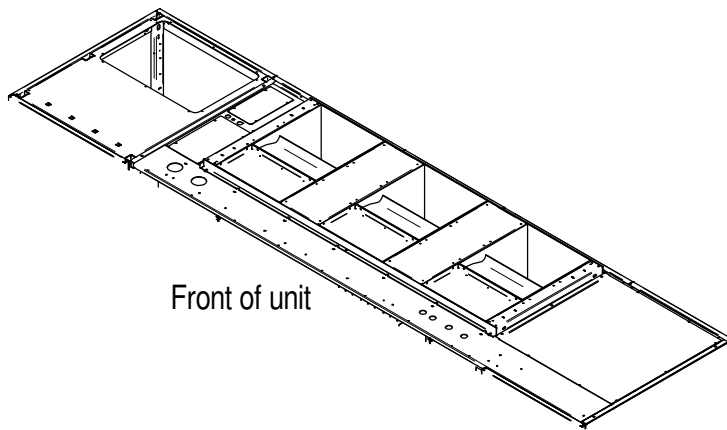
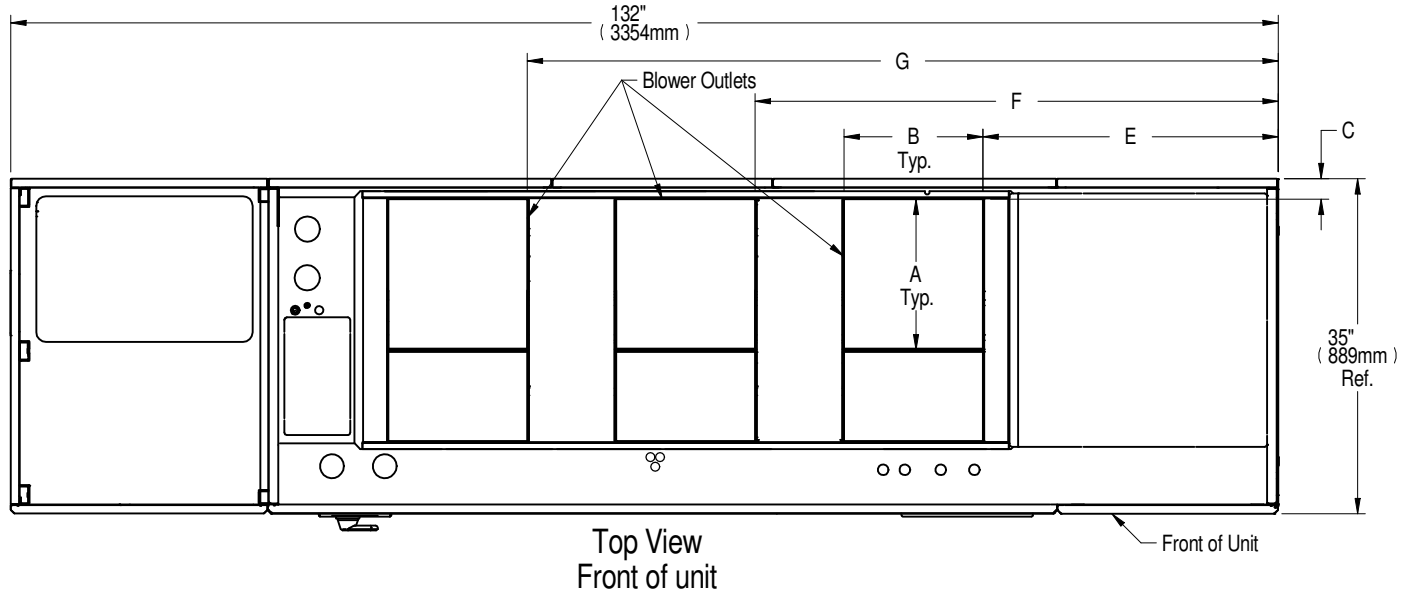

BLOWER	SUPPLY	DIMENSIONAL DATA inches (mm)						
		A	B	C	D	E	F	G
15 x 11	FRONT THROW	15-7/8 (404)	14-3/4 (375)	2-1/8 (54)	24-5/8 (625)	30-3/4 (781)	54-1/2 (1384)	78-1/4 (1988)
	REAR THROW			11-5/8 (295)				

**REAR RETURN FILTER BOX DIMENSIONAL DATA
UPFLOW 35-105kW (10-30 TONS) ALL COMPRESSOR MODELS
W/ FORWARD CURVED BLOWERS**

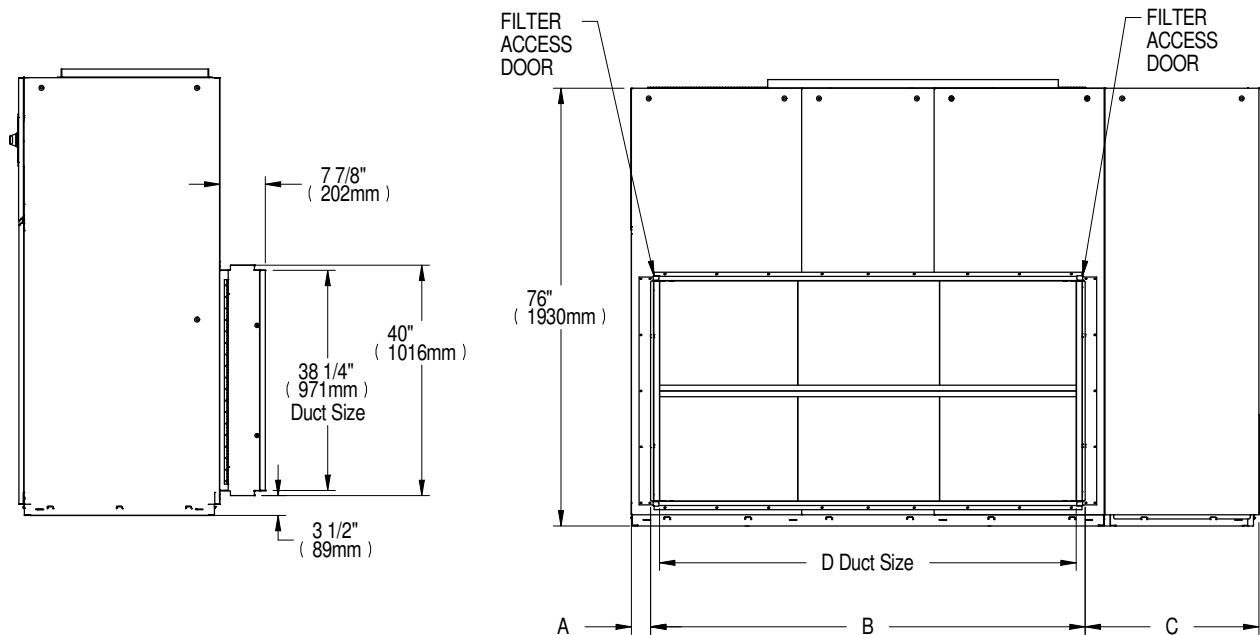

Notes:

1. Filters can be accessed from either side.
2. 25" (635mm) minimum clearance provided on one side for filter access.
3. Filter boxes are shipped flat and must be field assembled.

4.  Digital Scroll compressors not available on Air Cooled 42kW models.

Rear Return Filter Box Dimensional Data in (mm)					
	A	B	C	D	# Filters
35-42kW, Air-Cooled Scroll and Air-Cooled Digital Scroll Models 	4-1/4 (108)	50-3/4 (1289)	18 (457)	47-5/8 (1210)	4
35-42kW all Water/Glycol/GLYCOOL Models			31 (787)		
53-70kW, Air-Cooled Scroll and Air-Cooled Digital Scroll Models	3-1/4 (83)	75-1/2 (1918)	19-1/4 (489)	72-3/8 (1838)	6
53-70kW all Water/Glycol/GLYCOOL Models			30-1/4 (768)		
77kW, Air Cooled Scroll Models			19-1/4 (489)		
77kW, All Semi-hermetic Models and all Water/Glycol/GLYCOOL Models			30-1/4 (768)		
105kW, All Models	2-1/4 (57)	100-1/4 (2546)	29-1/2 (749)	97-1/8 (2467)	8

REAR RETURN FILTER BOX DIMENSIONAL DATA
UPFLOW 35-105kW (10-30 TONS) W/ EC FANS ALL COMPRESSOR MODELS

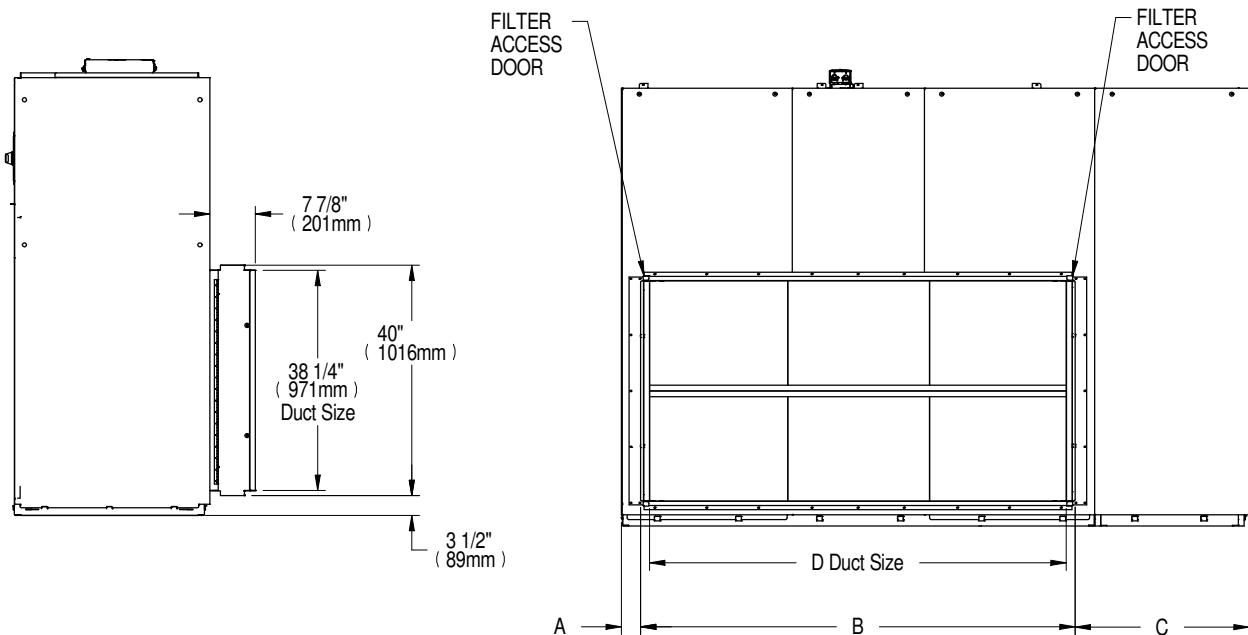

Notes:

1. Filters can be accessed from either side.
2. 25" (635mm) minimum clearance provided on one side for filter access.
3. Filter boxes are shipped flat and must be field assembled.

Rear Return Filter Box Dimensional Data in (mm)					
	A	B	C	D	# Filters
35-42kW, Air-Cooled Scroll and Air-Cooled Digital Scroll Models	4-1/4 (108)	50-3/4 (1289)	18 (457)	47-5/8 (1210)	4
35-42kW all Water/Glycol/GLYCOOL Models			31 (787)		
53-70kW, Air-Cooled Scroll and Air-Cooled Digital Scroll Models	3-1/4 (83)	75-1/2 (1918)	19-1/4 (489)	72-3/8 (1838)	6
53-70kW all Water/Glycol/GLYCOOL Models			30-1/4 (768)		
77kW, Air Cooled Scroll Models			19-1/4 (489)		
77kW, All Semi-hermetic Models and all Water/Glycol/GLYCOOL Models			30-1/4 (768)		
105kW, All Models	2-1/4 (57)	100-1/4 (2546)	29-1/2 (749)	97-1/8 (2467)	8

UPFLOW PLENUM DIMENSIONAL DATA

35kW-105kW (10-30 TONS) MODELS W/ FORWARD CURVED BLOWERS

FRONT VIEWS - CHECK ONE (1):

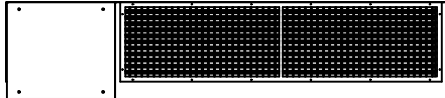

WITH FRONT GRILLE

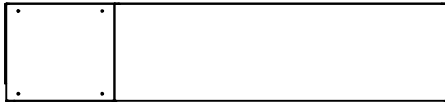

WITHOUT GRILLE

LEFT SIDE VIEWS - CHECK ONE (1):

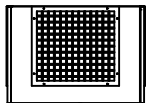

WITH GRILLE



WITHOUT GRILLE

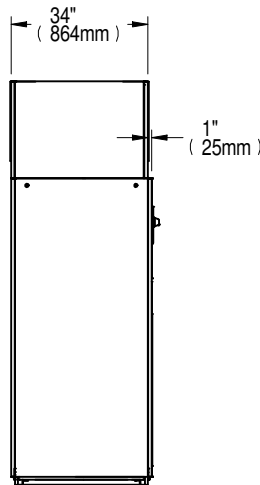

SIDE VIEW - UNIT WITH PLENUM

Panel removable for condenser clean out access (Water/Glycol/Glycool models only)

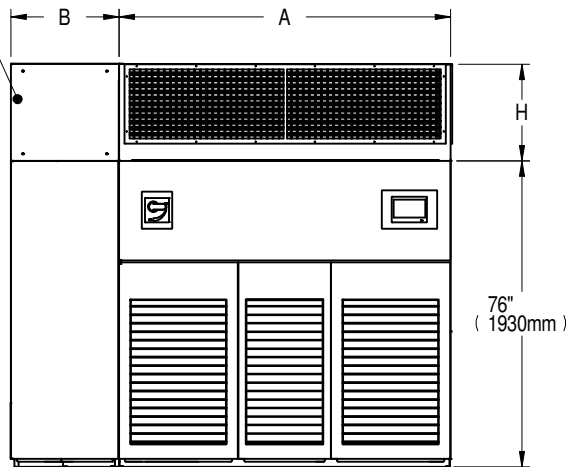

FRONT VIEW - UNIT WITH PLENUM

REAR VIEWS - CHECK ONE (1):

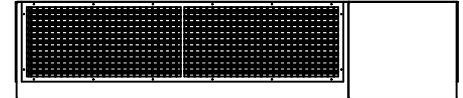

WITH REAR GRILLE

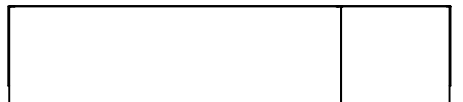

WITHOUT GRILLE

RIGHT SIDE VIEWS - CHECK ONE (1):

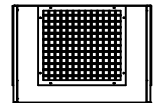

WITH GRILLE



WITHOUT GRILLE

Plenum Dimensional Data in (mm)	Plenum Dimensional Data in (mm)		Grille Size in (mm) - Nominal	
	A	B	Front/Rear Grilles	Side Grille
35kW-42kW, Air-Cooled Scroll and Air-Cooled Digital Scroll Models 35kW-42kW	59-1/4 (1505)	13-3/4 (349)	18 (457) X 55 (1397)	18 (457) X 20 (508)
Water/Glycol/GLYCOOL Models		26-3/4 (679)		
53kW-70kW, Air-Cooled Scroll and Air-Cooled Digital Scroll Models 53kW-70kW	82-1/4 (2089)	15-3/4 (400)	18 (457) X 78 (1981)	
Water/Glycol/GLYCOOL Models		26-3/4 (679)		
77kW, Air-Cooled Scroll Models		15-3/4 (400)		
77kW, All Semi-Hermetic Models and all Water/Glycol/GLYCOOL Models		26-3/4 (679)		
105kW, All Models	105-1/4 (2673)		(1) 18 (457) X 20 (508) (1) 18 (457) X 78 (1981)	

Height H in (mm)	PLENUM CONFIGURATION
20 (508)	NON GRILLED
24 (610)	NON-GRILLED, FRONT DISCHARGE OR REAR DISCHARGE
36 (914)	NON-GRILLED

Notes:

1. Typical 53kW-77kW (15-22 Tons) unit orientation shown with grille Plenum. View varies by unit size and Plenum selection.
2. Optional grille Plenum kits must include front or rear grille.
3. Non-grille Plenums are open on the top and not designed with duct flange.
4. All Plenums are shipped flat and must be field assembled.

5. Digital Scroll compressors not available on Air Cooled 42kW models.

PLENUM DIMENSIONAL DATA
UPFLOW 35-42kW (10-12 TONS) MODELS W/ EC FANS

Notes:

1. All Plenums must be field assembled and EC Fans wired to unit.
2. Shaded areas indicate a recommended minimum CLEARANCE OF 36" (914mm) from the bottom of the unit to the top of the plenum.
3. Must have access to remove Front Grill or panel to remove EC Fans.
4. Top duct flanges on plenum top for Supply Air ducting when solid panel plenum is used.
5. Compressor Plenum is optional and must be ordered separately.
6. Air Cooled Scroll or Digital Scroll Compressor.
7. Water Cooled Scroll or Digital Scroll Compressor.

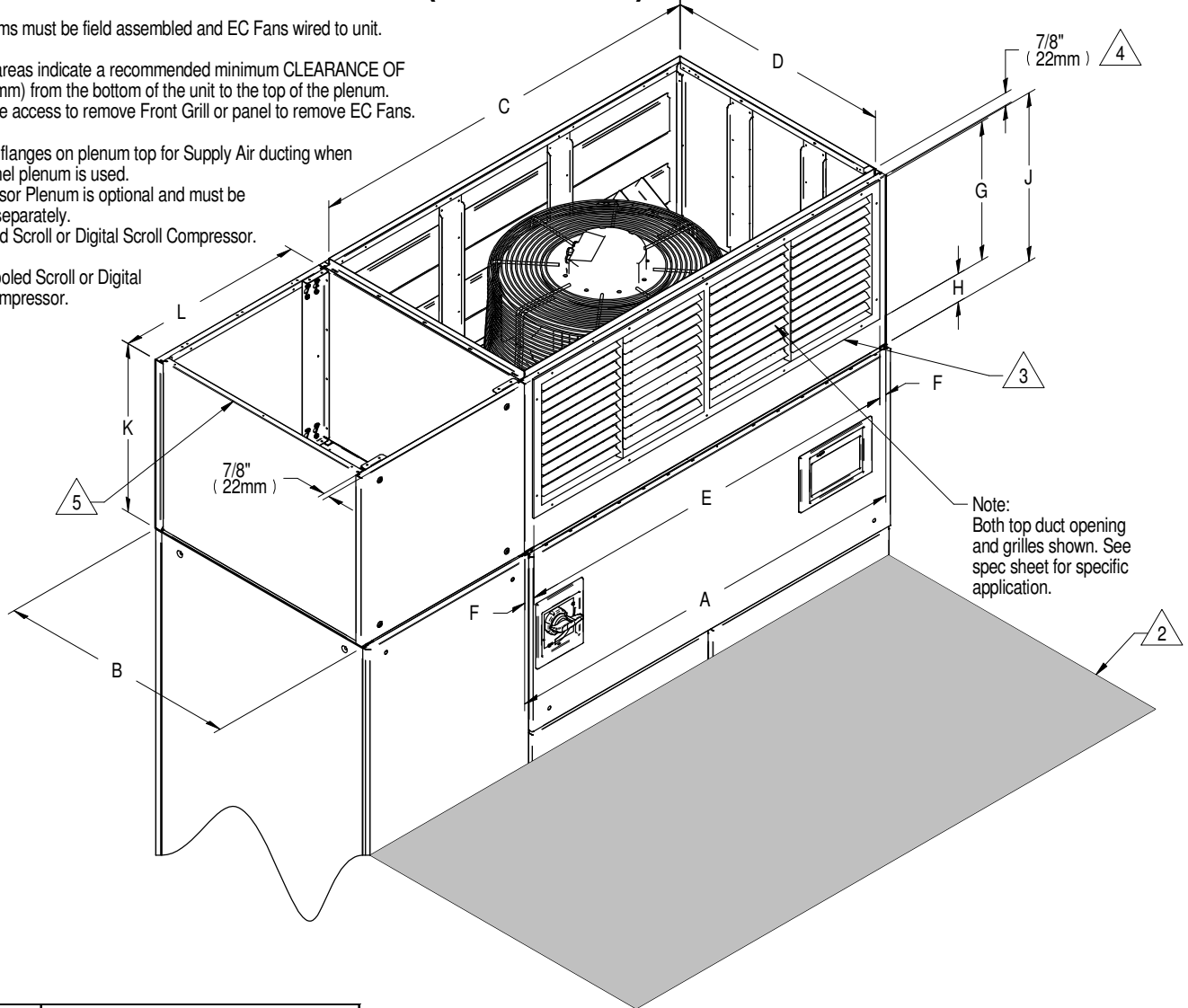

No. of Fans/Unit	EC Fan Assembly Weight lb. (kg)	
	VS028-VS035	VS042
1	119 (54)	141 (64)

Compressor Plenum		
Width L in. (mm)	Height K in. (mm)	Weight lb. (kg)
13 (330) △6	24 (610)	24 (11)
	30 (762)	26 (12)
	36 (914)	29 (13)
26 (660) △7	24 (610)	33 (15)
	30 (762)	37 (17)
	36 (914)	42 (19)

Main unit Plenum Height J in. (mm)	Main Unit Plenum Weight lb. (kg)		
	Non-grilled Plenum	Front Discharge	Rear Discharge
24 (610)	85 (39)	126 (57)	129 (59)
30 (762)	105 (48)	N/A	
36 (914)	123 (56)		

Plenum Dimensional Data in. (mm)							
A	B	C	D	E	F	G	H
59-1/4 (1505)	33-3/4 (857)	57-9/16 (1463)	32-1/16 (815)	56-11/16 (1440)	1-5/16 (33)	19-11/16 (500)	4-5/16 (109)

PLENUM DIMENSIONAL DATA UPFLOW 53-77kW (15-22 TONS) W/ EC FANS

Notes:

1. All Plenums must be field assembled and fans wired to unit.
2. Shaded areas indicate a recommended minimum clearance of 36" (914mm) from the bottom of the unit to the top of the plenum.
3. Must have access to remove Front Grill or panel to remove EC Fans.
4. Top duct flanges on plenum top for Supply Air ducting when solid panel plenum is used.
5. Compressor Plenum is optional and must be ordered separately.
6. Air-Cooled Scroll/Digital Scroll Compressor.
7. Water Cooled Scroll/Digital Scroll and Semi-Hermetic Compressor.

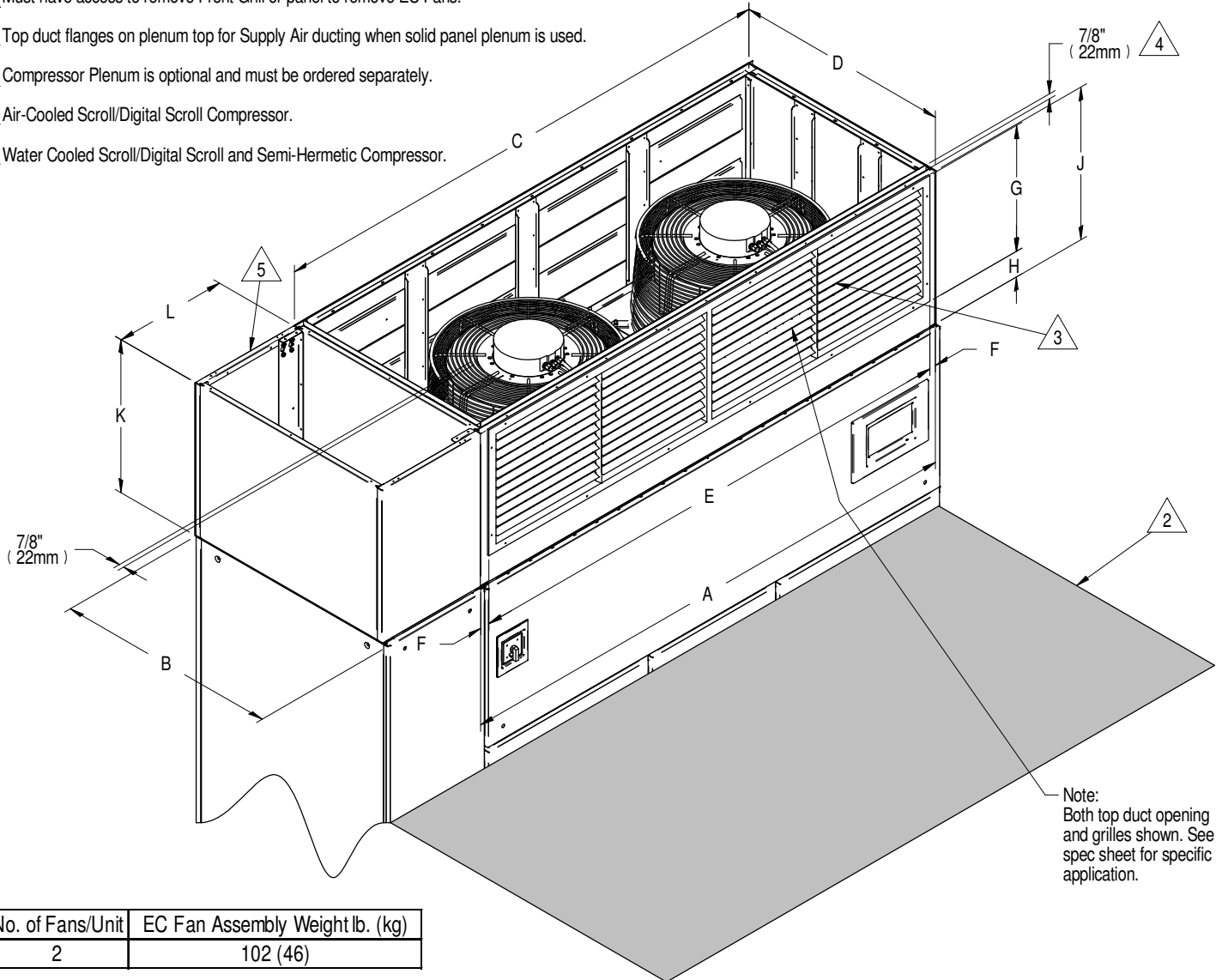

Note:
Both top duct opening and grilles shown. See spec sheet for specific application.

No. of Fans/Unit	EC Fan Assembly Weight lb. (kg)
2	102 (46)

Plenum Dimensional Data in. (mm)							
A	B	C	D	E	F	G	H
82 (2083)	34 (864)	81 (2057)	32 (813)	80 (2032)	1 (25)	20 (508)	4 (102)

Main unit Plenum Height J in. (mm)	Main unit Plenum weight lb. (kg)		
	Non-grilled plenum	Front discharge	Rear discharge
24 (610)	112 (51)	160 (73)	173 (79)
30 (762)	136 (62)	N/A	
36 (914)	156 (71)		

Compressor Plenum		
Width L in. (mm)	Height K in. (mm)	Weight lb. (kg)
15 (381)	24 (610)	26 (12)
	30 (762)	29 (13)
	36 (914)	31 (14)
26 (660)	24 (610)	33 (15)
	30 (762)	37 (17)
	36 (914)	42 (19)

PLENUM DIMENSIONAL DATA UPFLOW 105kW (30 TONS) MODELS W/ EC FANS

Note:

1. All Plenums must be field assembled and EC Fans wired to unit.

2. Shaded areas indicate a recommended minimum CLEARANCE OF 36" (914mm) from the bottom of the unit to the top of the plenum.

3. Must have access to remove Front Grill or panel to remove EC Fans.

4. Top duct flanges on plenum top for Supply Air ducting when solid panel plenum is used.

5. Compressor Plenum is optional and must be ordered separately.

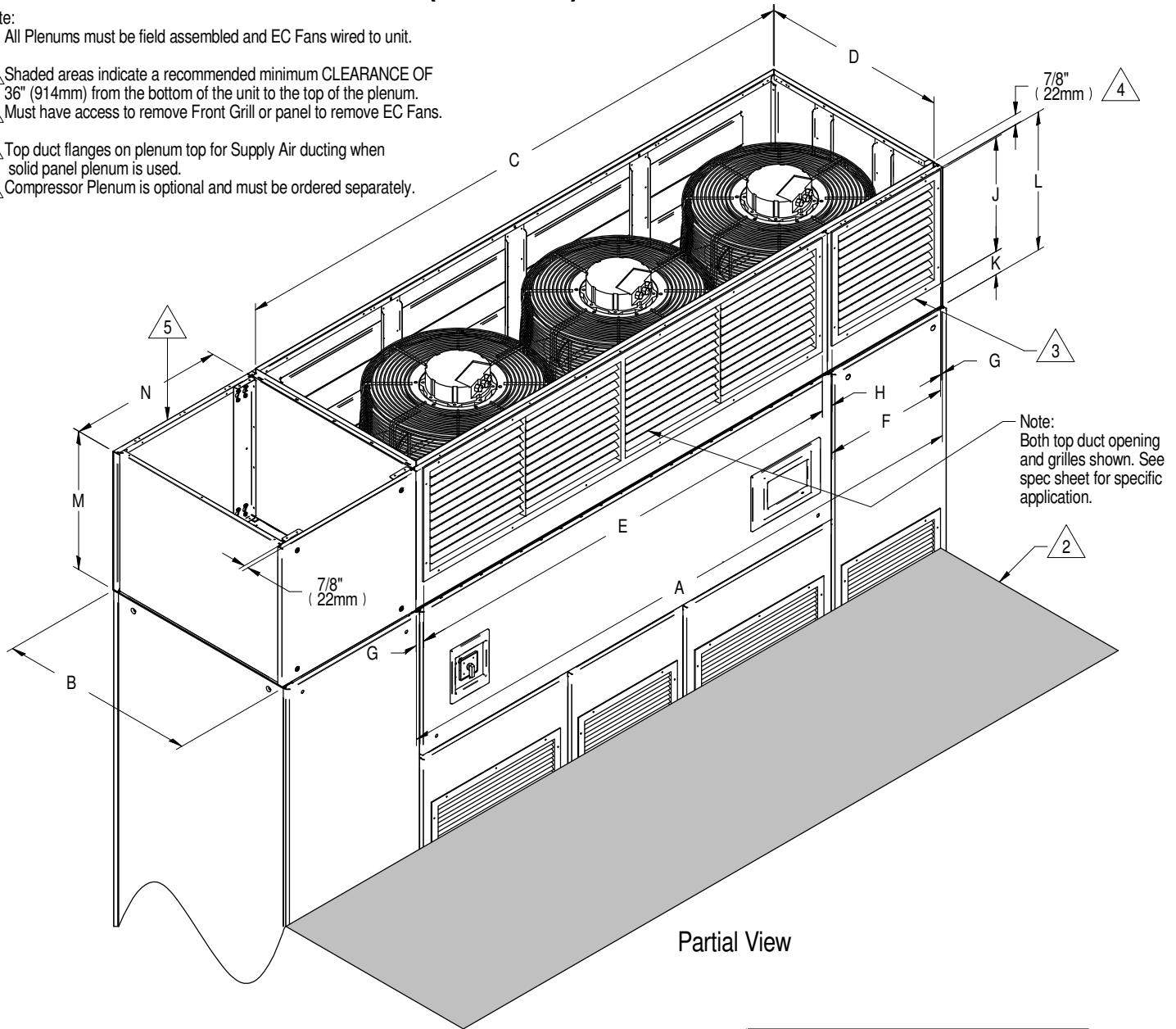

Main unit Plenum Height L in. (mm)	Main unit Plenum weight lb. (kg)		
	Non-grilled plenum	Front discharge	Rear discharge
24 (610)	131 (59)	206 (93 kg)	220 (100)
30 (762)	162 (74)	N/A	
36 (914)	188 (85)		

Compressor Plenum		
Width N in. (mm)	Height M in. (mm)	Weight lb. (kg)
26	24 (610)	33 (15)
	30 (762)	37 (17)
	36 (914)	42 (19)

Plenum Dimensional Data in. (mm)									
A	B	C	D	E	F	G	H	J	K
105 (2673)	34 (864)	104 (2641)	32 (813)	80 (2032)	22 (559)	1 (25)	2 (51)	20 (508)	4 (102)

No. of Fans/Unit	EC Fan Assembly Weight lb. (kg)
3	93 (42)

AIR COOLED PIPING SCHEMATIC CONDENSER ABOVE INDOOR UNIT

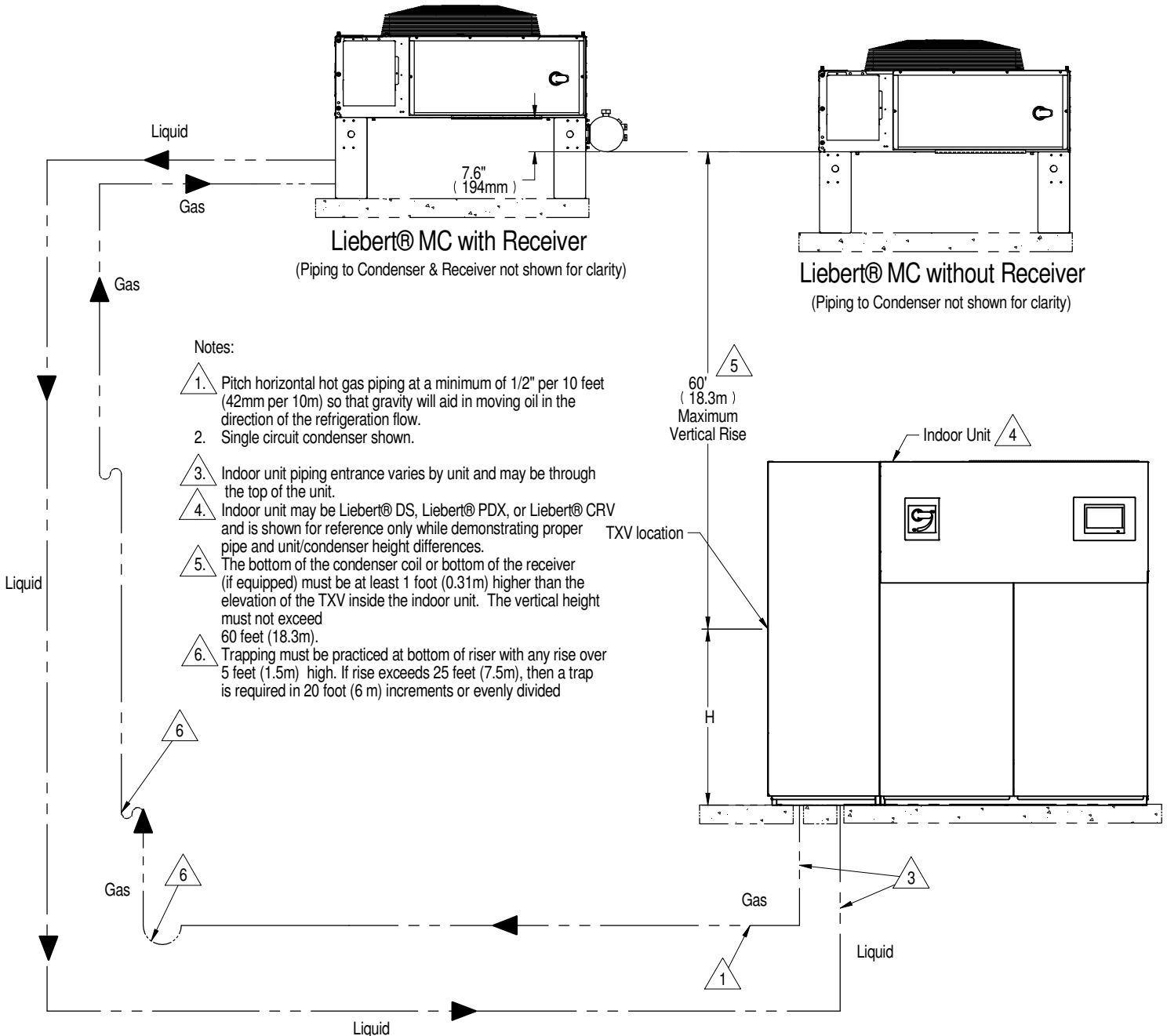

Internal TXV Height	H in. (mm)
Liebert® PDX Downflow	44 (1118)
Liebert® PDX Upflow	20 (508)
Liebert® DS	43 (1092)
Liebert® CRV - CR019	45 (1143)
Liebert® CRV - CR020/CR035	27 (686)

----- Field piping

AIR COOLED PIPING SCHEMATIC CONDENSER AND INDOOR UNIT AT SAME LEVEL

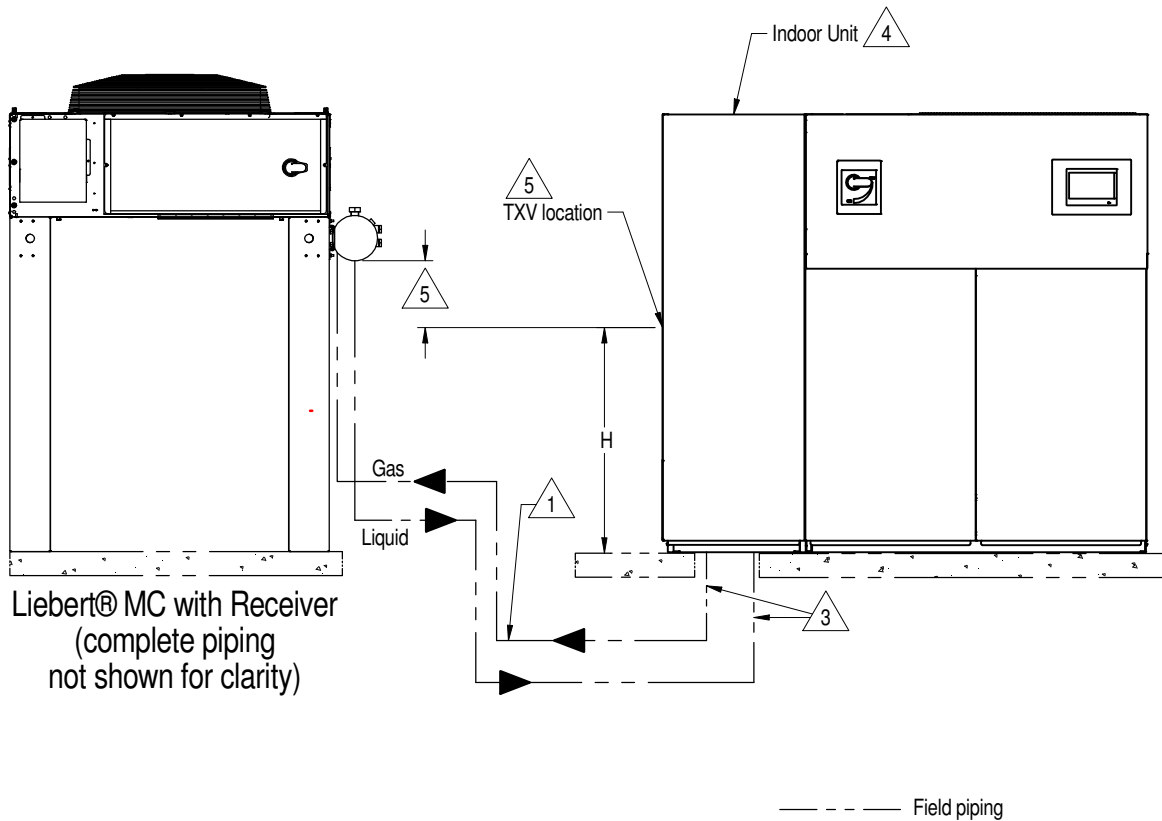

Liebert® MC with Receiver
(complete piping
not shown for clarity)

Notes:

1. Pitch horizontal hot gas piping at a minimum of 1/2" per 10 feet (42mm per 10m) so that gravity will aid in moving oil in the direction of the refrigeration flow.
2. Single circuit condenser shown.
3. Indoor unit piping entrance varies by unit and may be through the top of the unit.
4. Indoor unit may be Liebert® DS, Liebert® PDX, or Liebert® CRV and is shown for reference only.
5. The bottom of the receiver must be at least 1 foot (0.31m) higher than the elevation of the TXV inside the indoor unit, otherwise extended legs or a field piped subcooler needs to be utilized.

Internal TXV Height	H in. (mm)
Liebert® PDX Downflow	44 (1118)
Liebert® PDX Upflow	20 (508)
Liebert® DS	43 (1092)
Liebert® CRV - CR019	45 (1143)
Liebert® CRV - CR020/CR035	27 (686)

AIR COOLED PIPING SCHEMATIC CONDENSER AND INDOOR UNIT AT SAME LEVEL

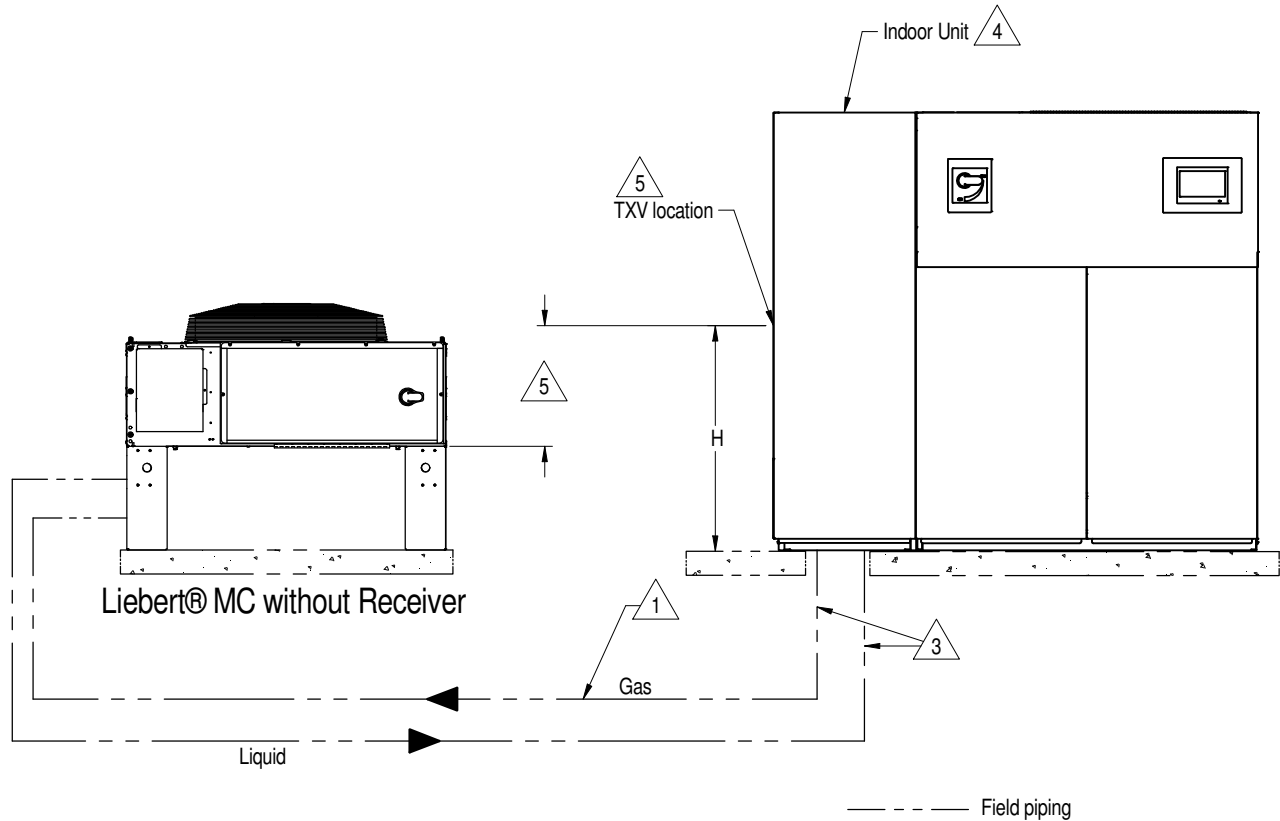

Notes:

1. Pitch horizontal hot gas piping at a minimum of 1/2" per 10 feet (42mm per 10m) so that gravity will aid in moving oil in the direction of the refrigeration flow.
2. Single circuit condenser shown.
3. Indoor unit piping entrance varies by unit and may be through the top of the unit.
4. Indoor unit may be Liebert® DS, Liebert® PDX, or Liebert® CRV and is shown for reference only.
5. The bottom of the coil must be less than 15' (4.6m) below the elevation of the TXV inside the indoor unit.

Internal TXV Height	H in. (mm)
Liebert® PDX Downflow	44 (1118)
Liebert® PDX Upflow	20 (508)
Liebert® DS	43 (1092)
Liebert® CRV - CR019	45 (1143)
Liebert® CRV - CR020/CR035	27 (686)

AIR COOLED PIPING SCHEMATIC CONDENSER BELOW INDOOR UNIT

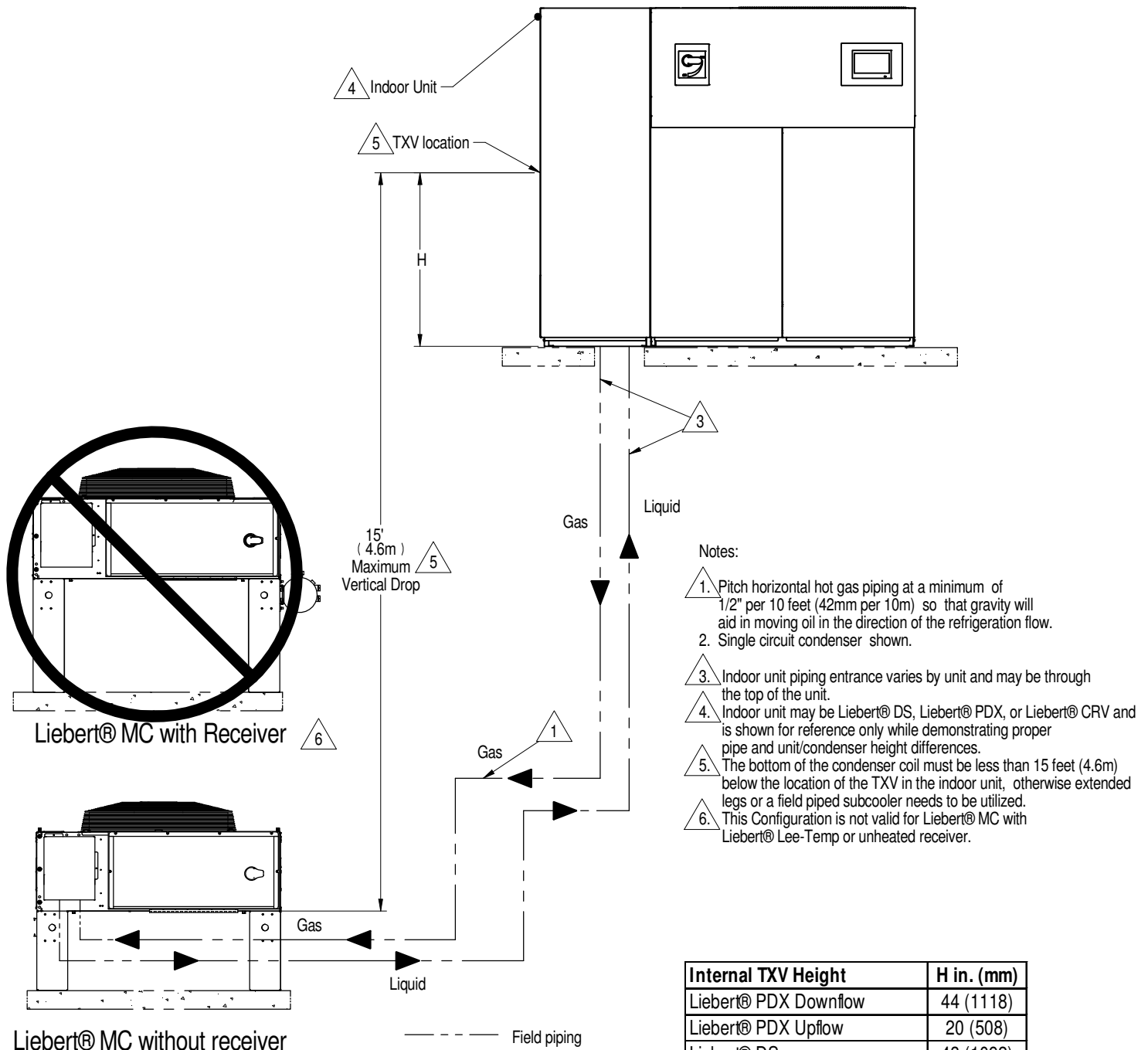

Internal TXV Height	H in. (mm)
Liebert® PDX Downflow	44 (1118)
Liebert® PDX Upflow	20 (508)
Liebert® DS	43 (1092)
Liebert® CRV - CR019	45 (1143)
Liebert® CRV - CR020/CR035	27 (686)

PIPING SCHEMATIC W/ LIEBERT® MC AIR COOLED SCROLL OR DIGITAL SCROLL COMPRESSOR MODELS

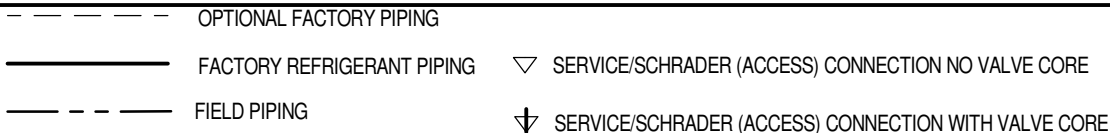
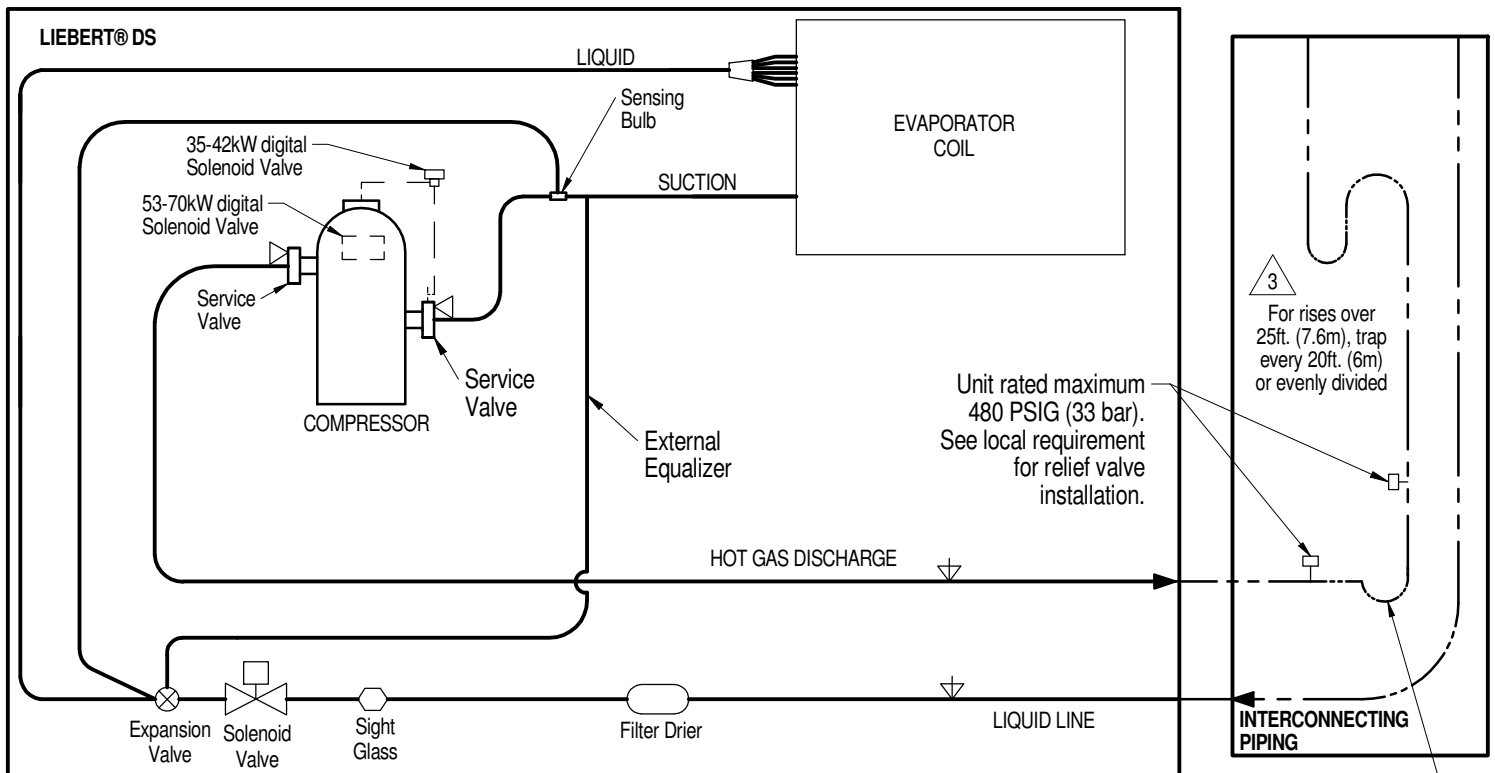
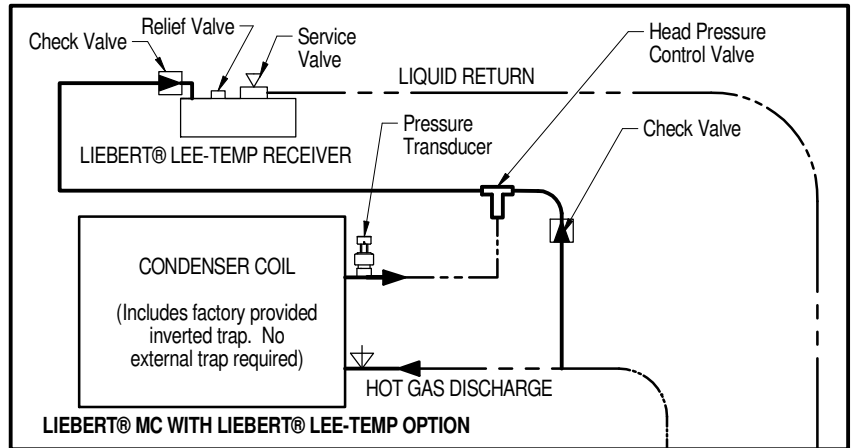
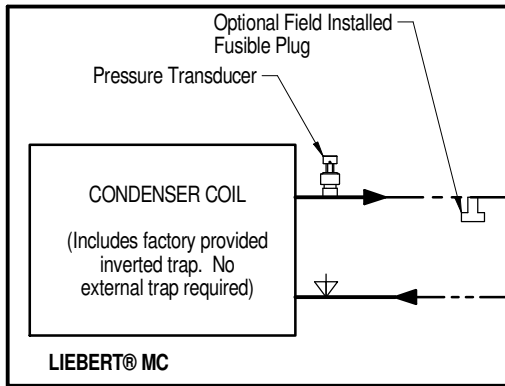

Notes:

- Single refrigeration circuit shown for clarity.
- Schematic representation shown. Do not use for specific connection locations.
- Components are not supplied by Vertiv, but are required for proper operation and maintenance.
- Traps must be installed and horizontal lines pitched to ensure proper oil return and to reduce liquid floodback to compressor. Pitch horizontal hot gas piping at a minimum of 1/2" per 10 feet (42mm per 10m) so that gravity will aid in moving oil in the direction of the refrigeration flow.
- Do not isolate any refrigerant circuits from over pressurization protection.

PIPING SCHEMATIC WATER/GLYCOL SCROLL COMPRESSOR MODELS

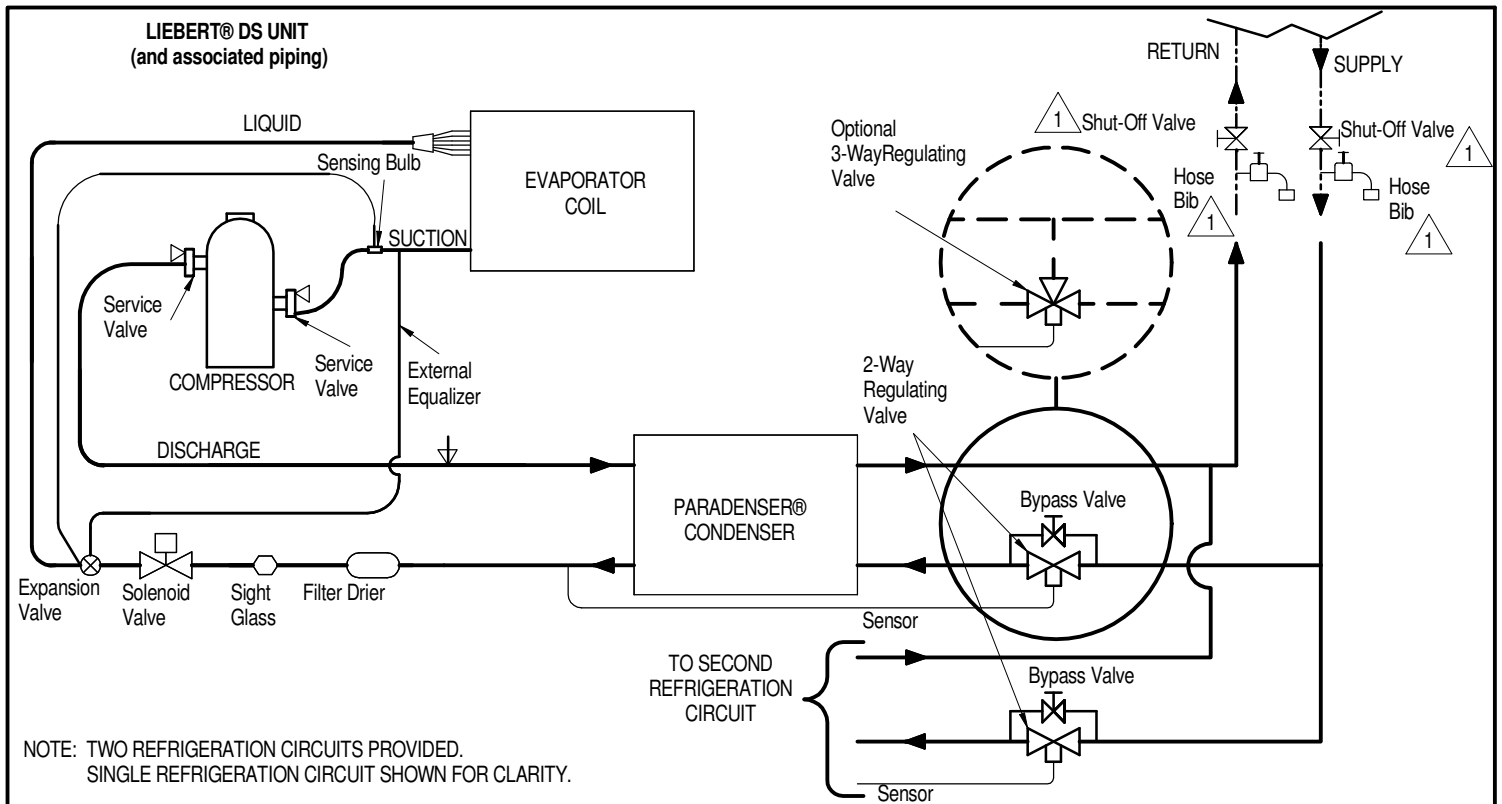
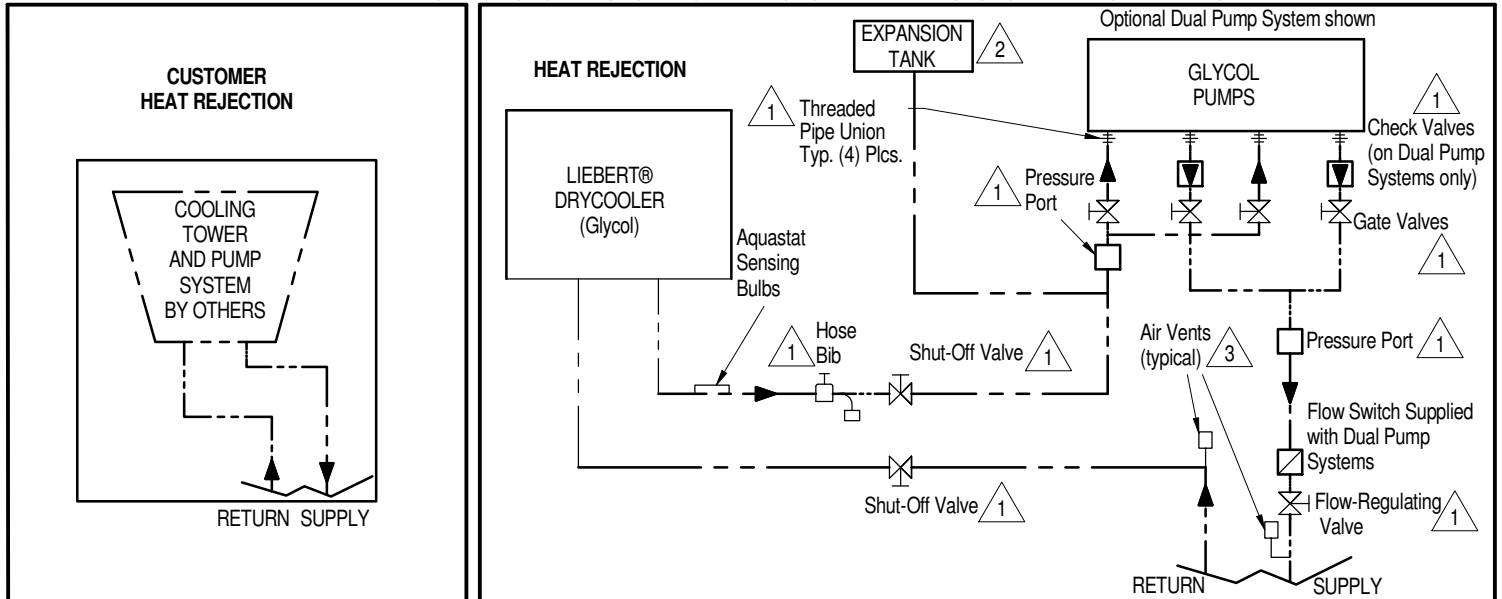

NOTE: TWO REFRIGERATION CIRCUITS PROVIDED.
SINGLE REFRIGERATION CIRCUIT SHOWN FOR CLARITY.

- FACTORY PIPING
- - - FIELD PIPING
- - - - - OPTIONAL FACTORY PIPING
- ▽ SERVICE / SCHRADER (ACCESS) CONNECTION NO VALVE CORE
- ▽ SERVICE / SCHRADER (ACCESS) CONNECTION WITH VALVE CORE

NOTE: SCHEMATIC REPRESENTATION SHOWN. THIS SCHEMATIC DOES NOT IMPLY OR DEFINE ELEVATIONS AND COMPONENT LOCATION, UNLESS SPECIFICALLY NOTED.

- 1 Components are not supplied by Vertiv but are required for proper operation and maintenance
- 2 Field installed at highest point in system on return line to pumps
- 3 Locate at tops of all risers and any intermediate system high points

PIPING SCHEMATIC WATER/GLYCOL DIGITAL SCROLL COMPRESSOR MODELS

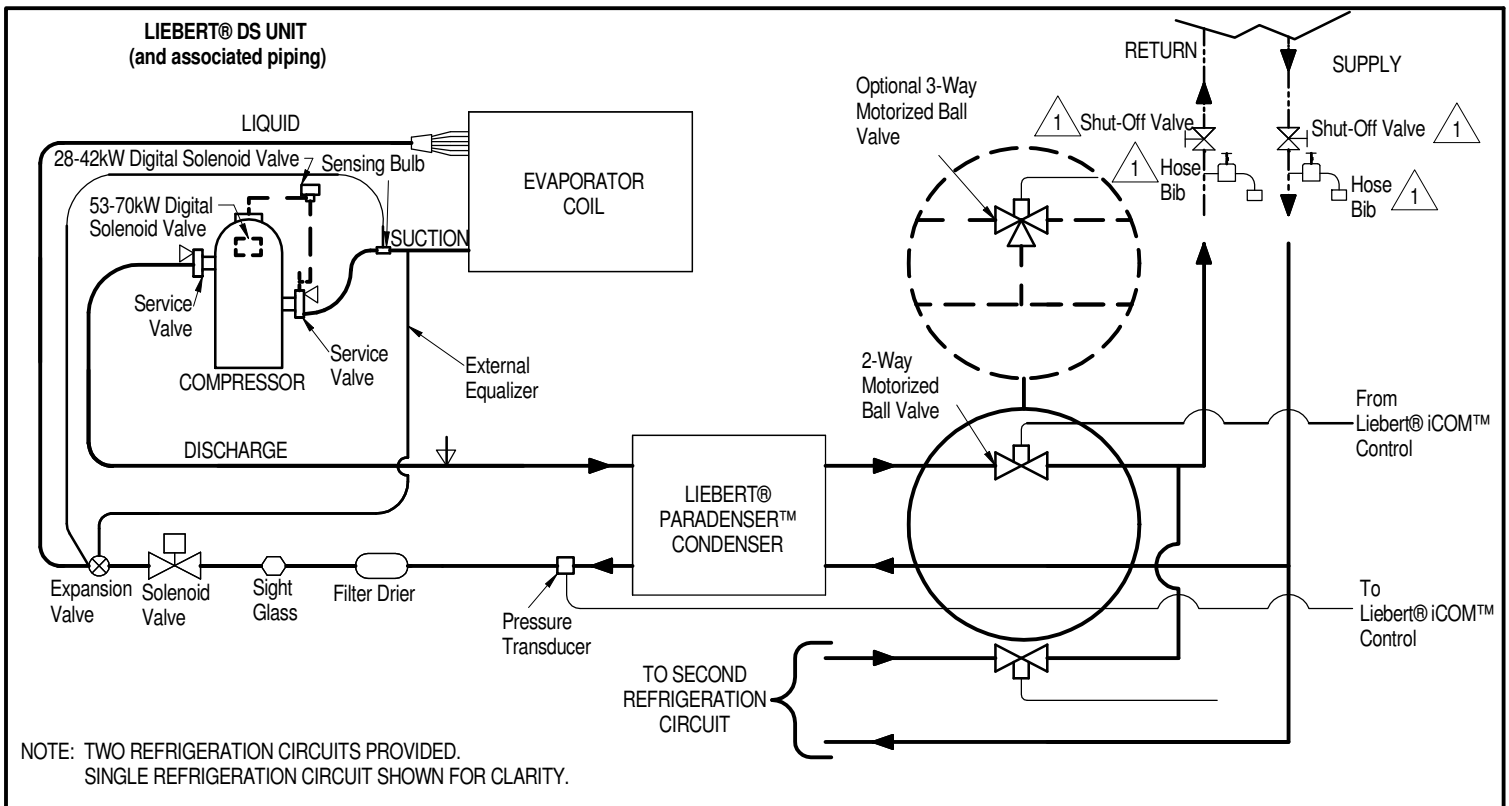
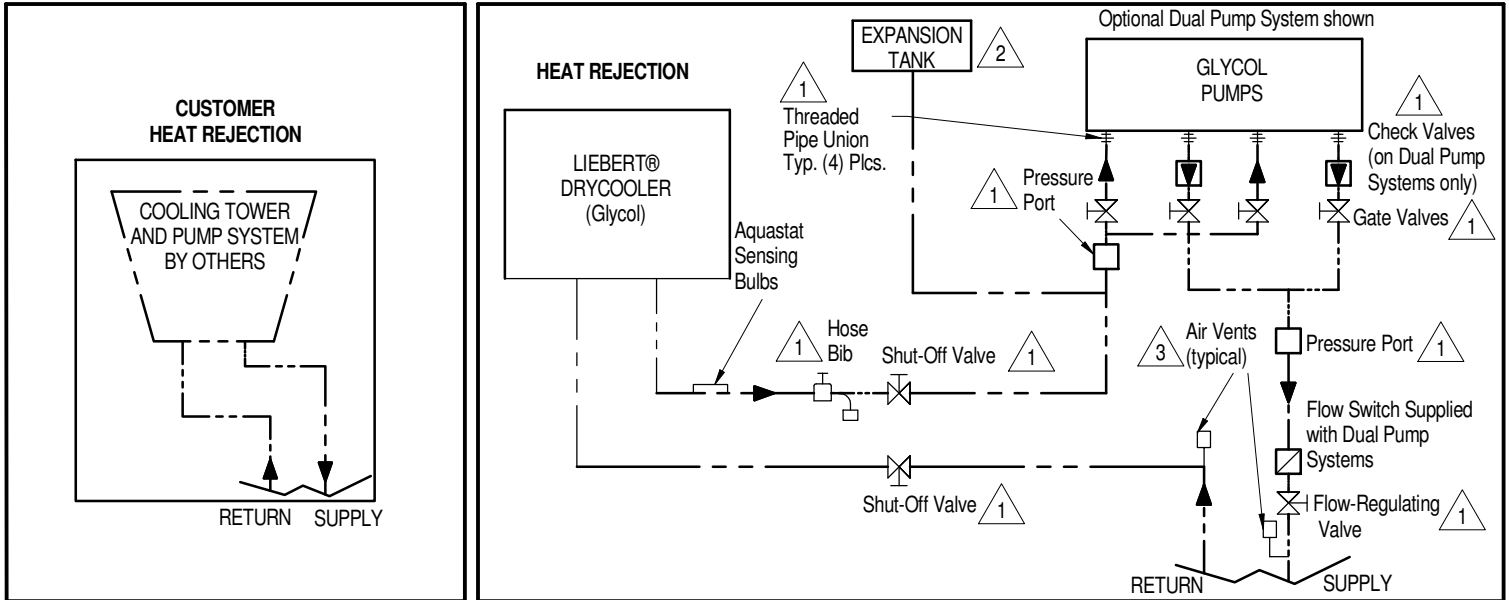

NOTE: TWO REFRIGERATION CIRCUITS PROVIDED.
SINGLE REFRIGERATION CIRCUIT SHOWN FOR CLARITY.

- FACTORY PIPING
- - - - - FIELD PIPING
- - - - - OPTIONAL FACTORY PIPING
- ▽ SERVICE / SCHRADER (ACCESS) CONNECTION NO VALVE CORE
- ▽ SERVICE / SCHRADER (ACCESS) CONNECTION WITH VALVE CORE

NOTE: SCHEMATIC REPRESENTATION SHOWN. THIS SCHEMATIC DOES NOT IMPLY OR DEFINE ELEVATIONS AND COMPONENT LOCATION, UNLESS SPECIFICALLY NOTED.

- 1 Components are not supplied by Vertiv but are required for proper operation and maintenance
- 2 Field installed at highest point in system on return line to pumps
- 3 Locate at tops of all risers and any intermediate system high points

PIPING SCHEMATIC

WATER/GLYCOL 77kW - 105kW SEMI-HERMETIC COMPRESSOR MODELS

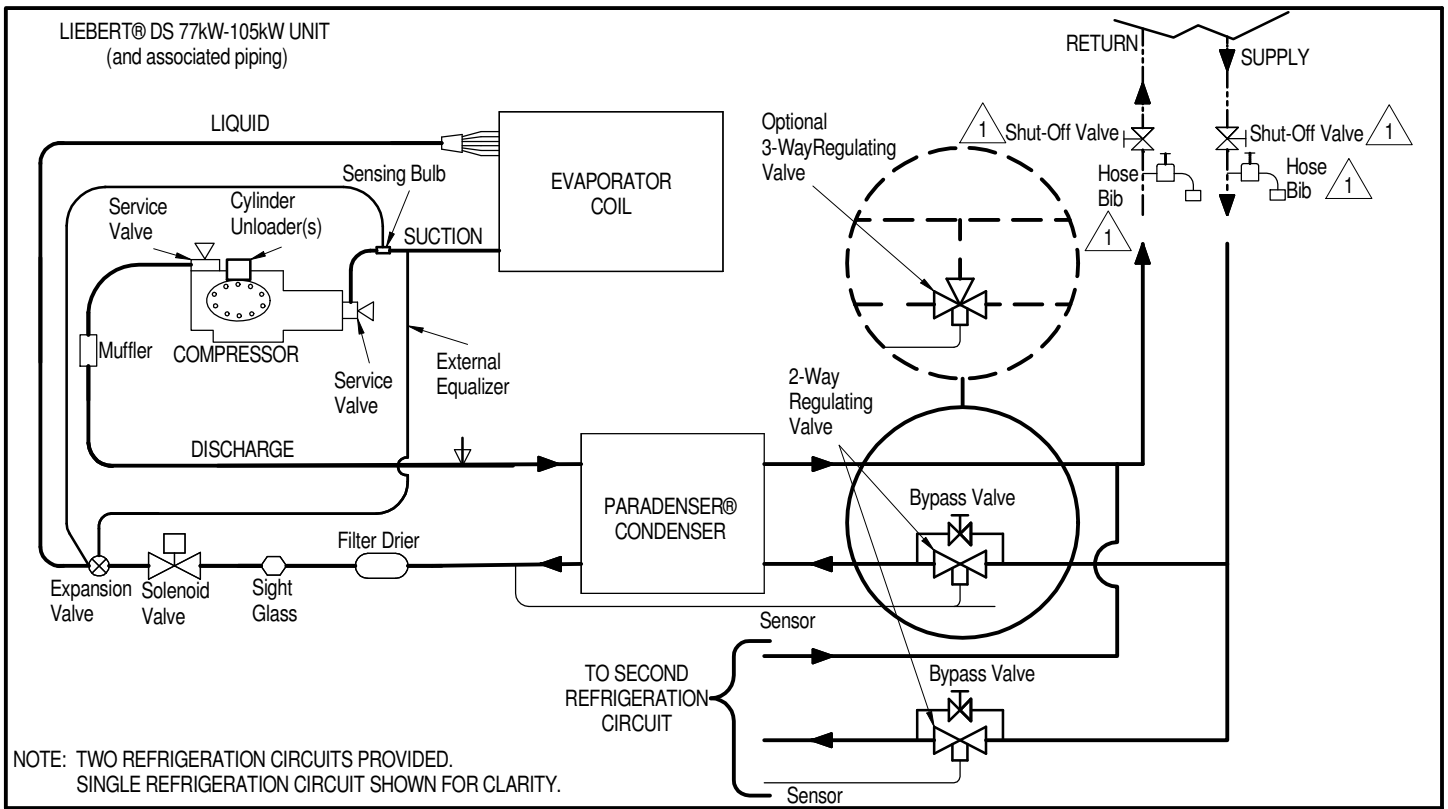
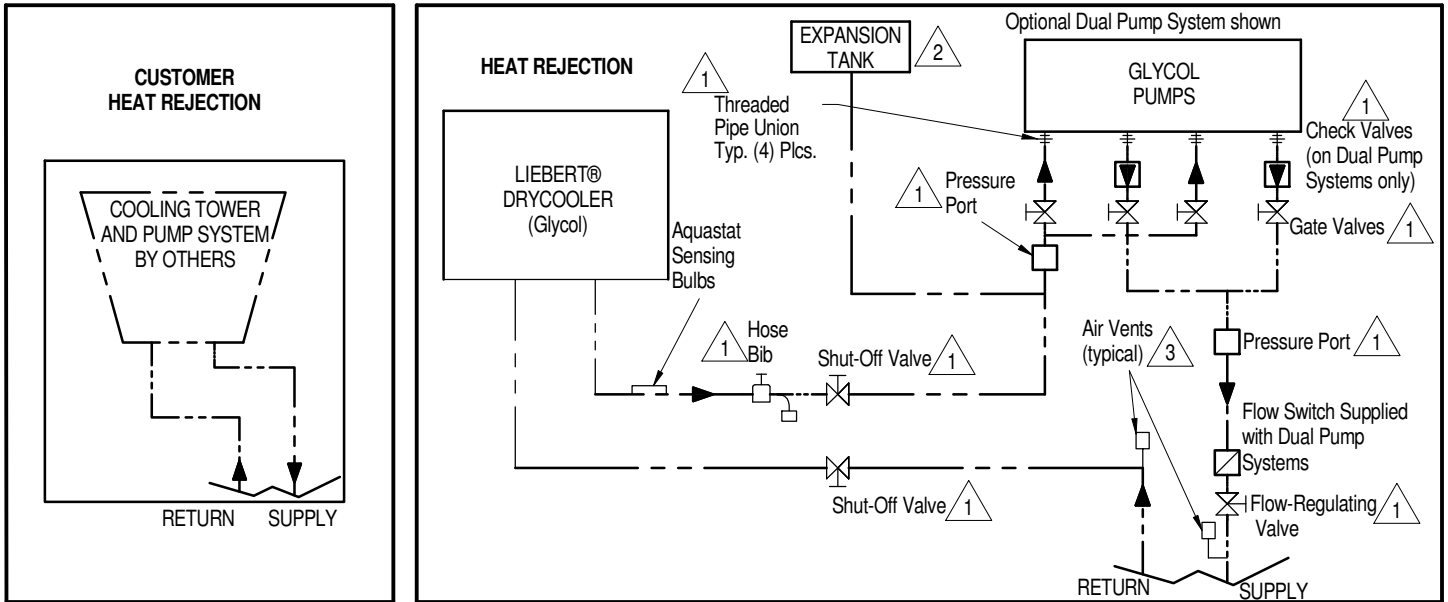

NOTE: TWO REFRIGERATION CIRCUITS PROVIDED. SINGLE REFRIGERATION CIRCUIT SHOWN FOR CLARITY.

- FACTORY PIPING
- - - - - FIELD PIPING
- · - · - · OPTIONAL FACTORY PIPING
- ▽ SERVICE / SCHRADER (ACCESS) CONNECTION NO VALVE CORE
- ▽ SERVICE / SCHRADER (ACCESS) CONNECTION WITH VALVE CORE

NOTE: SCHEMATIC REPRESENTATION SHOWN. THIS SCHEMATIC DOES NOT IMPLY OR DEFINE ELEVATIONS AND COMPONENT LOCATION, UNLESS SPECIFICALLY NOTED.

- 1. Components are not supplied by Vertiv but are required for proper operation and maintenance
- 2. Field installed at highest point in system on return line to pumps
- 3. Locate at tops of all risers and any intermediate system high points

PIPING SCHEMATIC

GLYCOOL 77kW - 105kW SEMI-HERMETIC COMPRESSOR MODELS

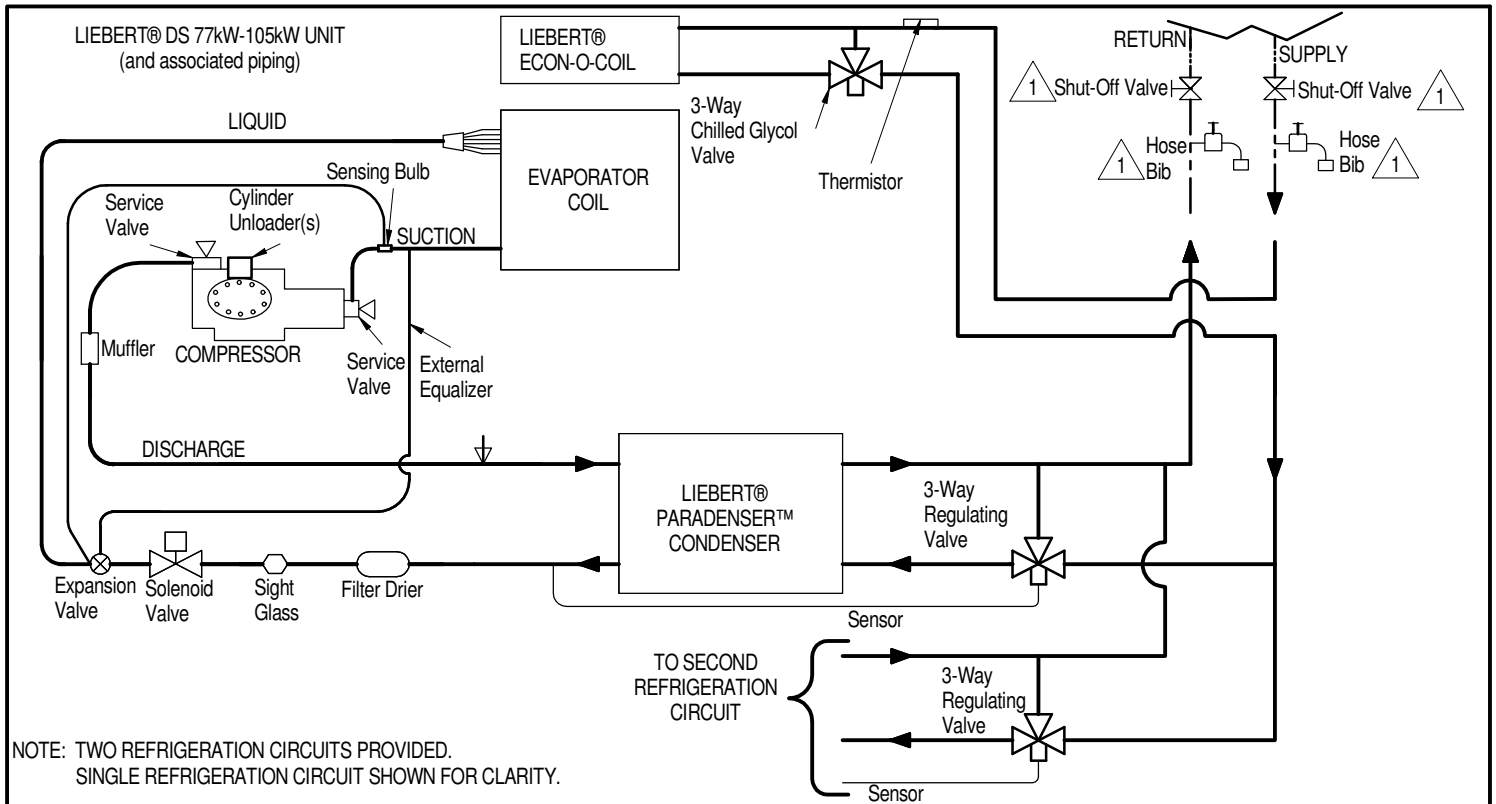
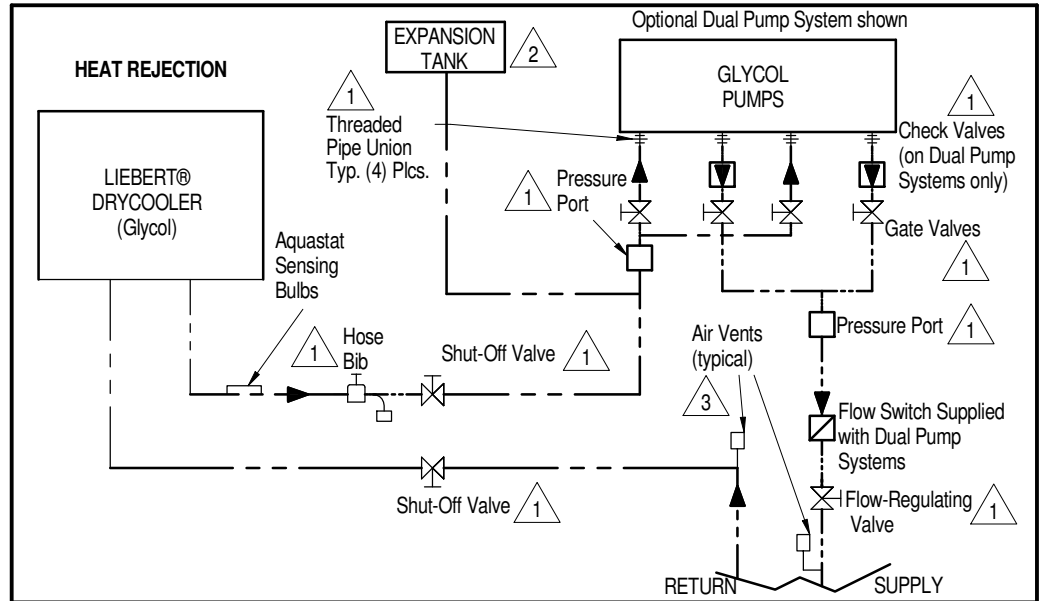

- FACTORY PIPING
- - - - - FIELD PIPING
- ▽ SERVICE / SCHRADER (ACCESS) CONNECTION NO VALVE CORE
- ▽ SERVICE / SCHRADER (ACCESS) CONNECTION WITH VALVE CORE

1. Components are not supplied by Vertiv but are required for proper operation and maintenance. Field installed at highest point in system on return line to pumps.
2. Field installed at highest point in system on return line to pumps.
3. Locate at tops of all risers and any intermediate system high points.

NOTE: SCHEMATIC REPRESENTATION SHOWN. THIS SCHEMATIC DOES NOT IMPLY OR DEFINE ELEVATIONS AND COMPONENT LOCATION, UNLESS SPECIFICALLY NOTED.

PIPING SCHEMATIC GLYCOL DIGITAL SCROLL COMPRESSOR MODELS

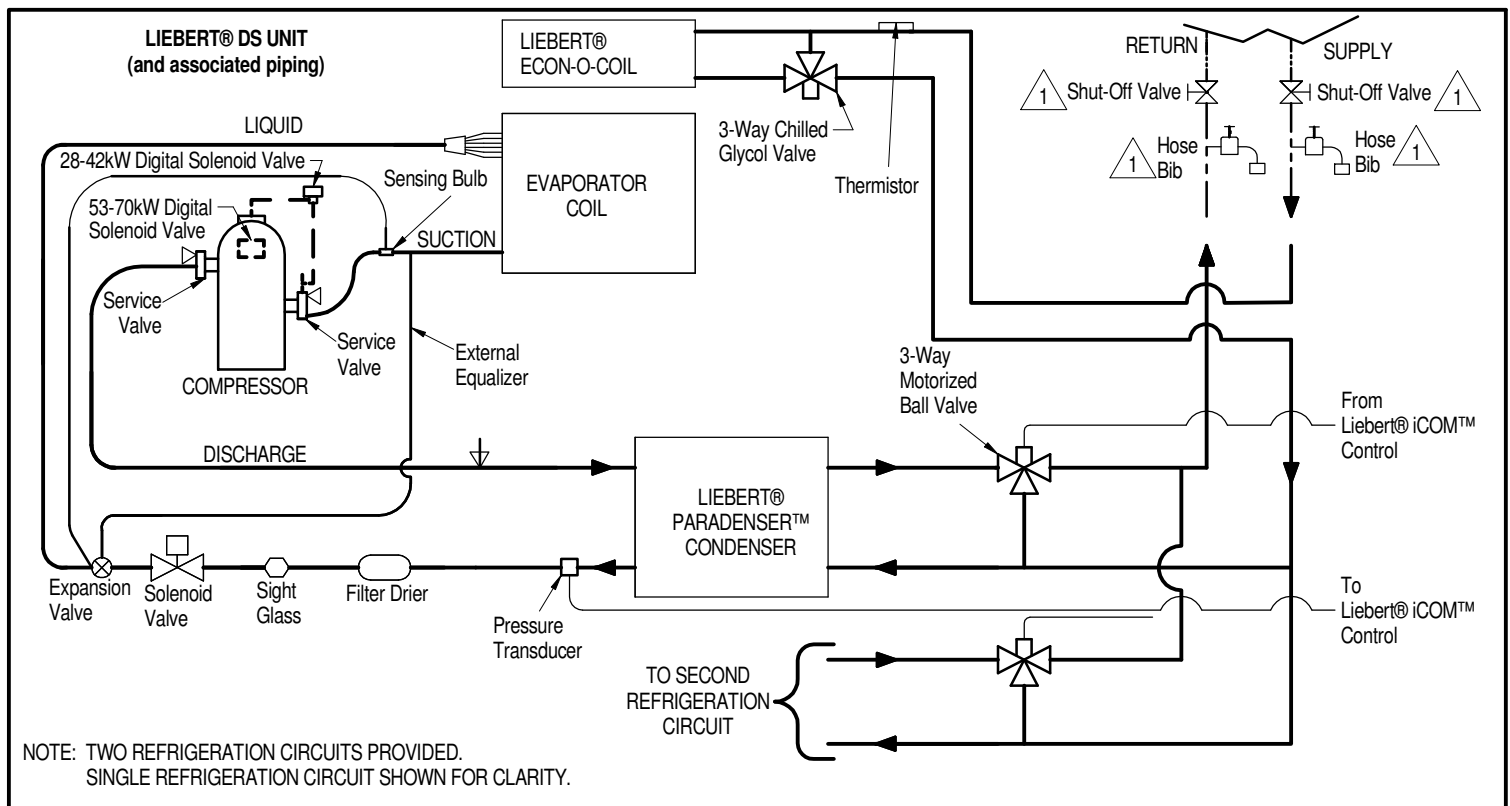
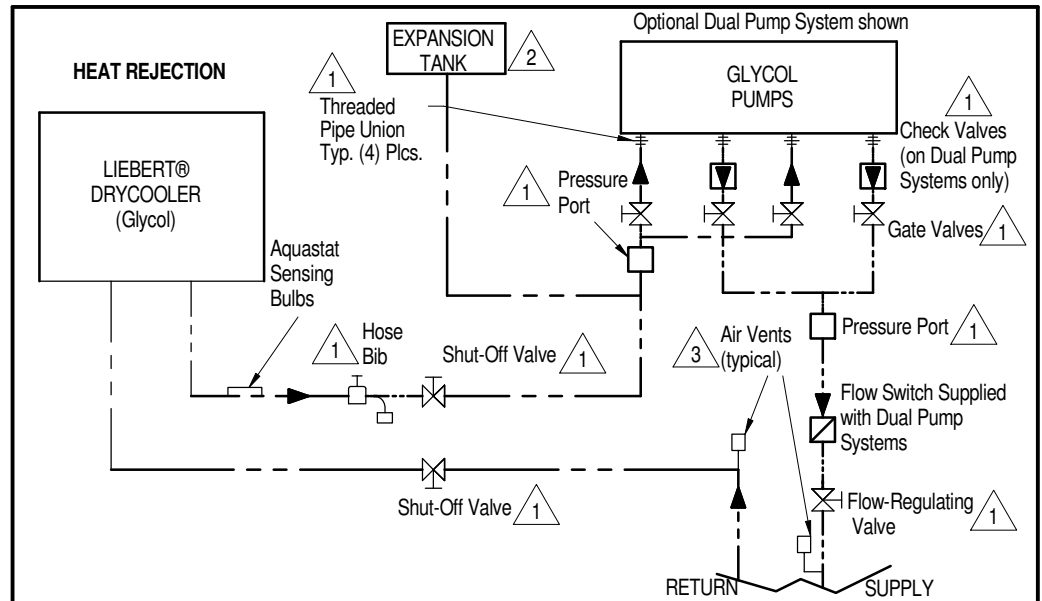

NOTE: TWO REFRIGERATION CIRCUITS PROVIDED.
SINGLE REFRIGERATION CIRCUIT SHOWN FOR CLARITY.

- OPTIONAL FACTORY PIPING
- ==== FACTORY PIPING
- - - - FIELD PIPING
- ▽ SERVICE / SCHRADER (ACCESS) CONNECTION NO VALVE CORE
- ▽ SERVICE / SCHRADER (ACCESS) CONNECTION WITH VALVE CORE

NOTE: SCHEMATIC REPRESENTATION SHOWN. THIS SCHEMATIC DOES NOT IMPLY OR DEFINE ELEVATIONS AND COMPONENT LOCATION, UNLESS SPECIFICALLY NOTED.

- 1 Components are not supplied by Vertiv but are required for proper operation and maintenance
- 2 Field installed at highest point in system on return line to pumps
- 3 Locate at tops of all risers and any intermediate system high points

OPTIONAL PIPING SCHEMATIC LIEBERT® ECON-O-COIL MODELS

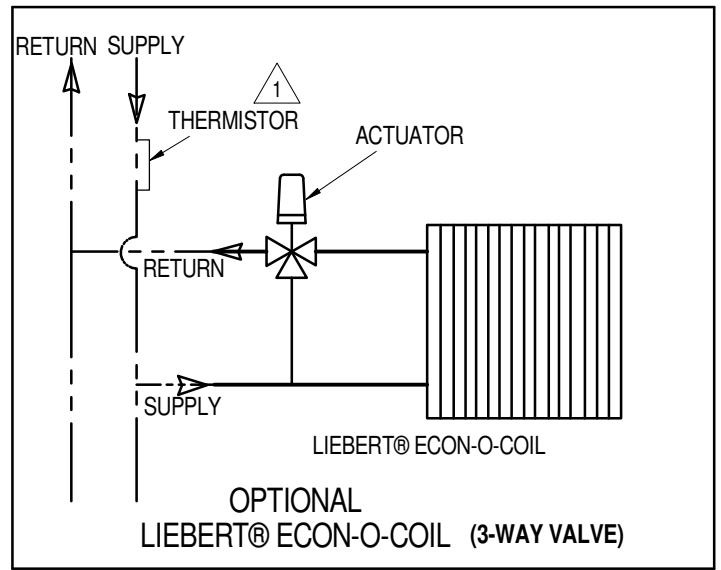
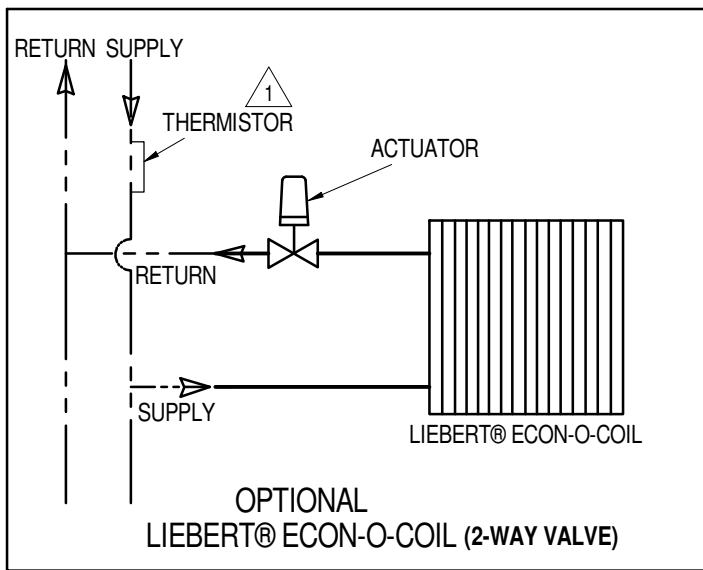

————— FACTORY PIPING
- - - - - FIELD PIPING

 SUPPLIED WITH 10 FEET EXTRA THERMISTOR WIRE FOR INSTALLATION ON FIELD SUPPLY LINE.

NOTE: 1) PLACE THERMISTOR IN LOCATION WHERE FLOW IS ALWAYS PRESENT.
2) THERMISTOR MUST BE LOCATED OUT OF THE SUPPLY AIR STREAM.

PIPING SCHEMATIC W/ LIEBERT® MC AIR COOLED DS077-105kW SEMI-HERMETIC COMPRESSOR MODELS

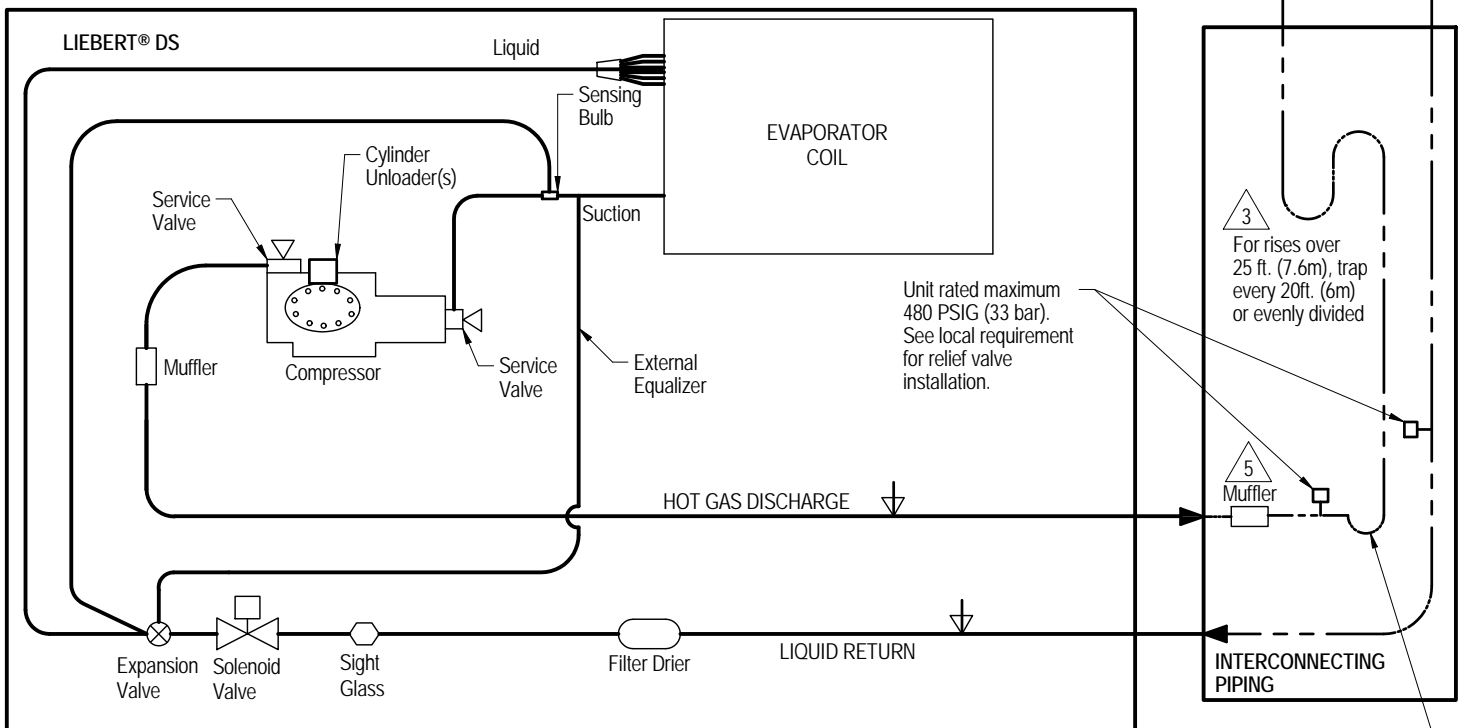
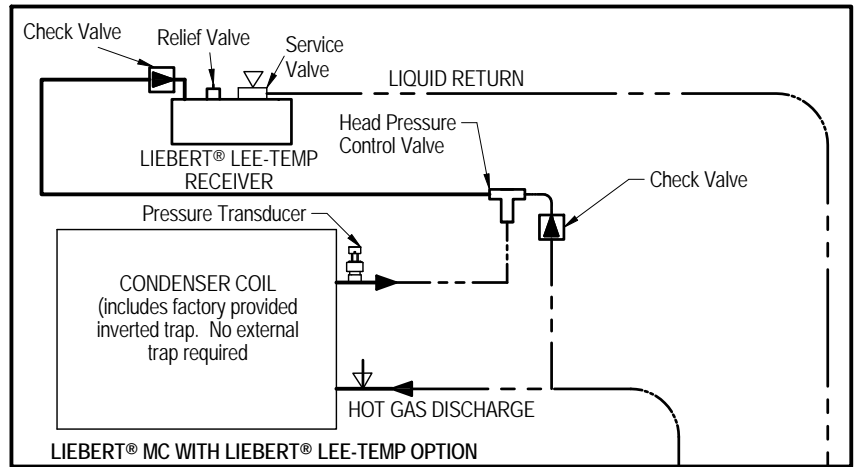
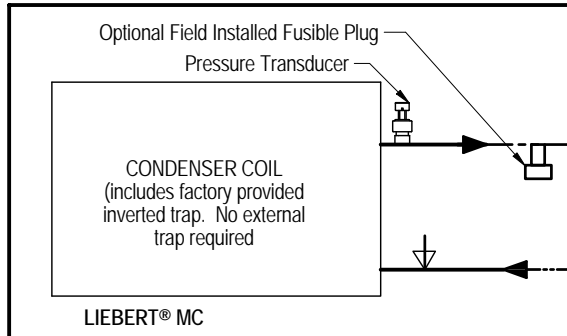

- FACTORY REFRIGERANT PIPING
- - - FIELD PIPING
- ▽ SERVICE/SCHRADER (ACCESS) CONNECTION NO VALVE CORE
- ▽ SERVICE/SCHRADER (ACCESS) CONNECTION WITH VALVE CORE

Notes:

1. Single refrigeration circuit shown for clarity.
2. Schematic representation shown. Do not use for specific connection locations.
3. Components are not supplied by Vertiv, but are required for proper operation and maintenance.
4. Traps must be installed and horizontal lines pitched to ensure proper oil return and to reduce liquid floodback to compressor. Pitch horizontal hot gas piping at a minimum of 1/2" per 10 feet (42mm per 10m) so that gravity will aid in moving oil in the direction of the refrigeration flow.
5. Component supplied by Vertiv and must be field installed.
6. Do not isolate any refrigerant circuits from over pressurization protection.

PRIMARY CONNECTION LOCATIONS DOWNFLOW AIR COOLED 35-42kW (10-12 TONS) SCROLL OR DIGITAL SCROLL COMPRESSOR MODELS

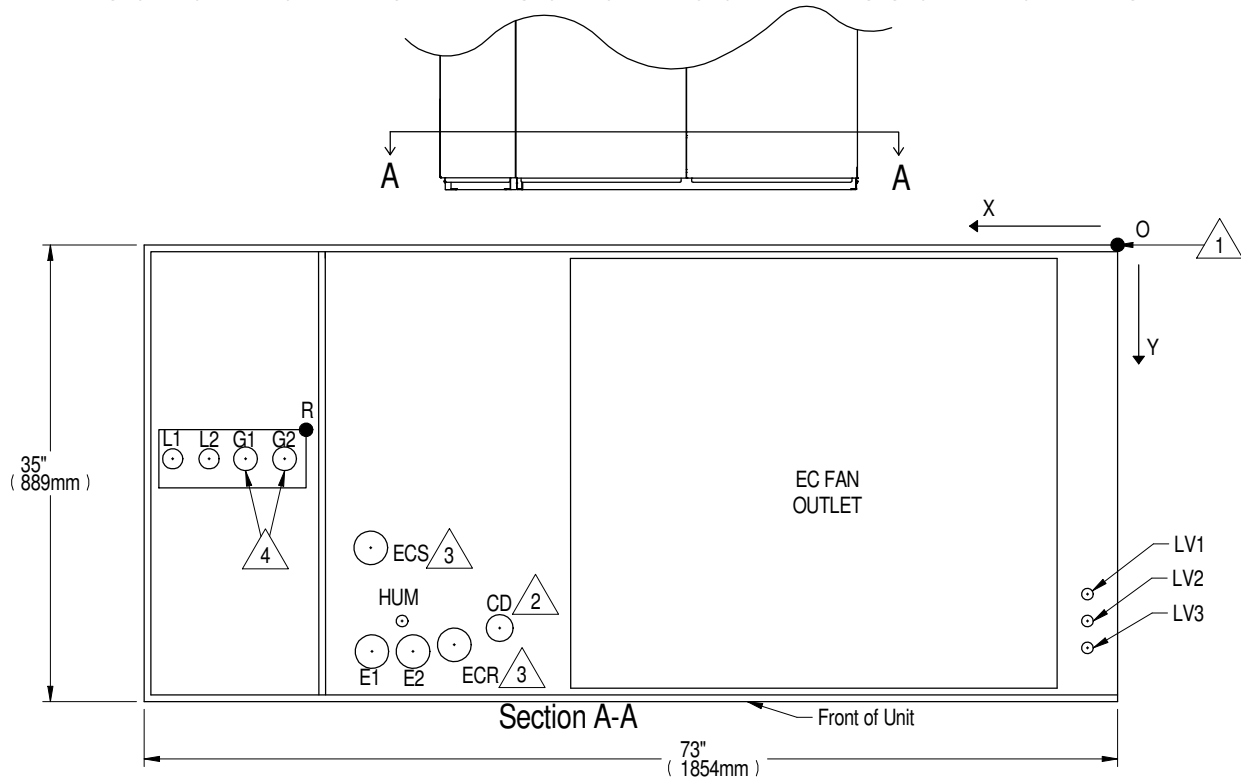

Notes:

1. Drawing not to scale. All dimensions from rear corner of unit including panels, and have a tolerance of $\pm 1/2"$ (13mm).
2. Field pitch Condensate Drain line a minimum of $1/8"$ (3.2 mm) per foot (305 mm). All units contain a factory installed condensate trap. Do not trap external to the unit. Select appropriate drain system materials. The drain line must comply with all local codes.
3. Supplied on Dual Cooling systems only.
4. When piping out the top of the unit, field must install traps in the discharge lines in the bottom of the unit before running lines to the top.

POINT	DESCRIPTION	X in. (mm)	Y in. (mm)	CONNECTION SIZE / OPENING
R	REFRIGERANT ACCESS	59-5/16 (1507)	14-3/4 (375)	11-3/16" (284mm) X 4" (102mm)
L1	LIQUID LINE SYSTEM 1	69-15/16 (1776)	16-13/16 (427)	1/2" O.D. Cu
L2	LIQUID LINE SYSTEM 2	67-5/8 (1718)		
G1 ⁴	HOT GAS DISCHARGE 1	65-1/2 (1664)		5/8" O.D. Cu
G2 ⁴	HOT GAS DISCHARGE 2	62-7/16 (1586)		
CD ²	CONDENSATE DRAIN (infrared humidifier or no humidifier) W/ OPTIONAL PUMP	46 (1168)	29-1/2 (749)	3/4" NPT FEMALE
HUM	HUMIDIFIER SUPPLY LINE	53-1/2 (1359)	29 (737)	1/4" O.D. Cu
ECS ³	LIEBERT® ECON-O-COIL SUPPLY	54-7/8 (1394)	22-9/16 (573)	1-5/8" O.D. Cu
ECR ³	LIEBERT® ECON-O-COIL RETURN	49-3/8 (1254)	30-3/4 (781)	
E1	ELECTRICAL CONN. (HIGH VOLT)	55-1/2 (1410)	31-1/4 (794)	2-1/2"
E2	ELECTRICAL CONN. (HIGH VOLT)	52-7/16 (1332)		
LV1	ELECTRICAL CONN. (LOW VOLT)	2-1/4 (57)	27 (686)	7/8"
LV2	ELECTRICAL CONN. (LOW VOLT)		29 (737)	
LV3	ELECTRICAL CONN. (LOW VOLT)		31 (787)	

PRIMARY CONNECTION LOCATIONS DOWNFLOW AIR COOLED 53-77kW SCROLL OR DIGITAL SCROLL COMPRESSOR MODELS W/ EC FANS

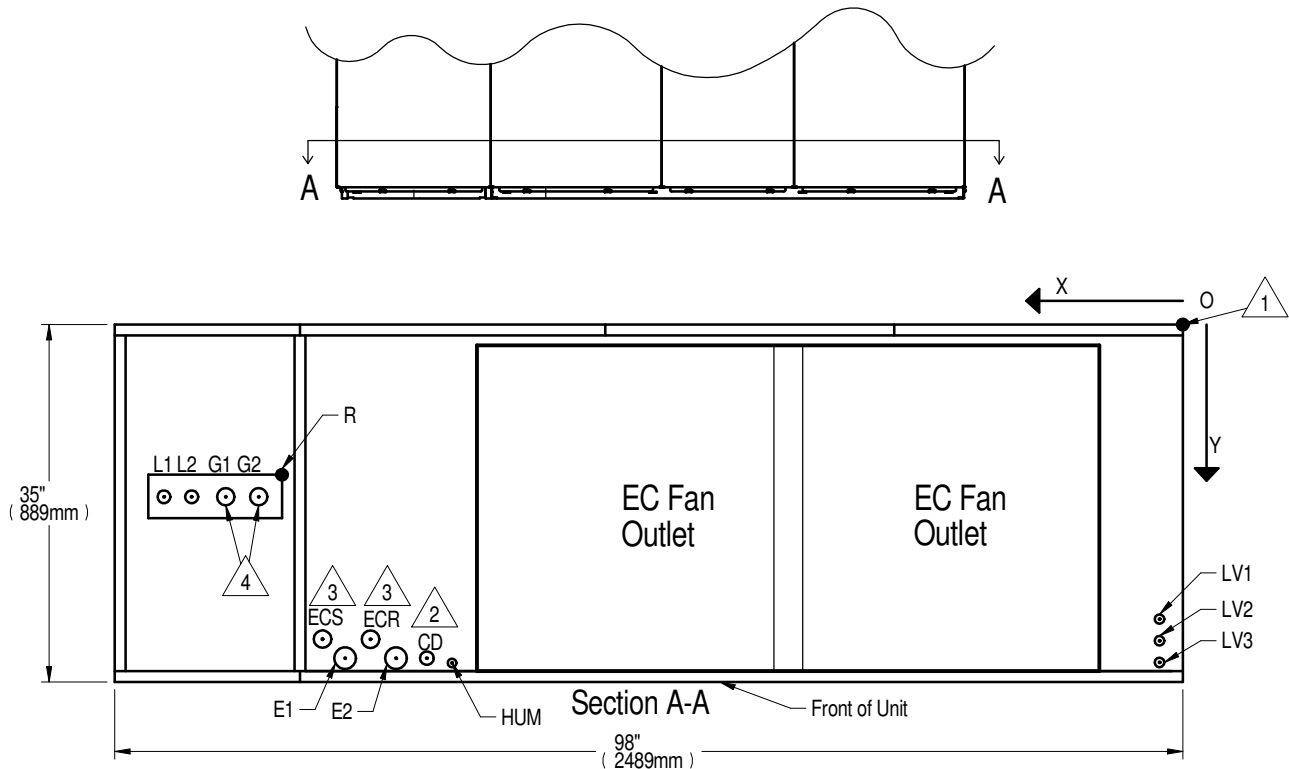

POINT	DESCRIPTION	X in. (mm)	Y in. (mm)	CONNECTION SIZE / OPENING	
R	REFRIGERANT ACCESS	81-3/4 (2076)	14-3/4 (375)	12-3/16" (310mm) X 4" (102mm)	
				53kW (15 TONS)	70 & 77kW (20 & 22 TONS)
L1	LIQUID LINE SYSTEM 1	94-11/16 (2405)	16-3/4 (425)	1/2" O.D. Cu	5/8" O.D. Cu
L2	LIQUID LINE SYSTEM 2	91-7/8 (2334)			
G1	HOT GAS DISCHARGE 1 ¹	88-3/4 (2254)	16-3/8 (416)	7/8" O.D. Cu	1-1/8" O.D. Cu
G2	HOT GAS DISCHARGE 2 ²	85-9/16 (2173)			
CD	CONDENSATE DRAIN ³ (infrared humidifier or no humidifier) W/ OPTIONAL PUMP	68-3/8 (1737)	31-3/8 (797)	3/4" NPT FEMALE	
				1/2" O.D. Cu	
HUM	HUMIDIFIER SUPPLY LINE	76-1/2 (1943)	29 (737)	1/4" O.D. Cu	
ECS	LIEBERT® ECON-O-COIL SUPPLY ³	78-5/8 (1997)	22-1/4 (565)	2-1/8" O.D. Cu	
ECR	LIEBERT® ECON-O-COIL RETURN ³	73-15/16 (1878)	26-9/16 (675)		
E1	ELECTRICAL CONN. (HIGH VOLT)	78-1/2 (1994)	31-1/8 (791)	2-1/2"	
E2		75-3/8 (1915)			
LV1	ELECTRICAL CONN. (LOW VOLT)	2 (51)	29 (737)	7/8"	
LV2			30-7/8 (784)		
LV3			32 (813)		

Notes:

- ¹. Drawing not to scale. All dimensions from rear corner of unit including panels, and have a tolerance of $\pm 1/2"$ (13mm).
- ². Field pitch Condensate Drain line a minimum of 1/8" (3.2 mm) per foot (305 mm). All units contain a factory installed condensate trap. Do not trap external to the unit. Select appropriate drain system materials. The drain line must comply with all local codes.
- ³. Supplied on Dual Cooling systems only.
- ⁴. When piping out the top of the unit, field must install traps in the discharge lines in the bottom of the unit before running lines to the top.
- ⁵. Digital Scroll compressor not available on DS077 models.

PRIMARY CONNECTION LOCATIONS DOWNFLOW AIR COOLED 77kW (22 TONS) SEMI-HERMETIC COMPRESSOR MODELS

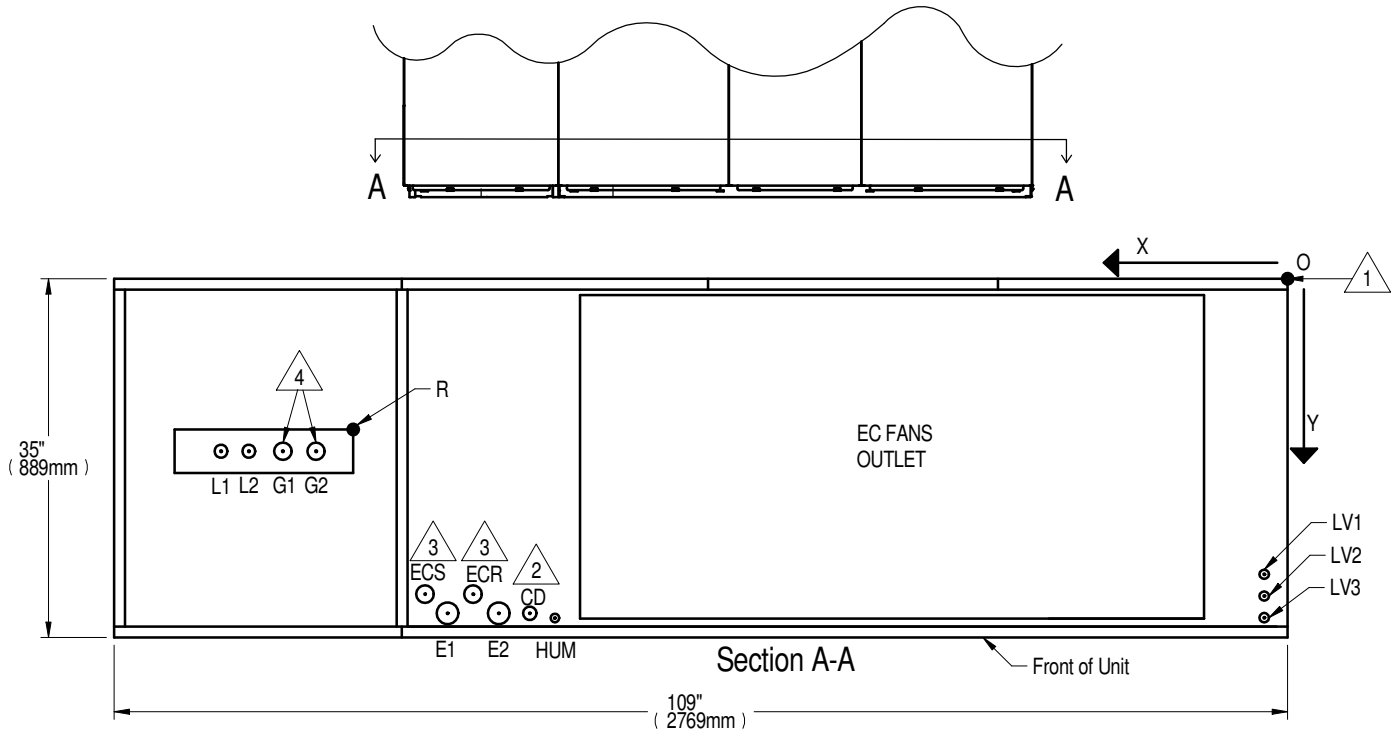

Notes:

1. Drawing not to scale. All dimensions from rear corner of unit including panels, and have a tolerance of $\pm 1/2"$ (13mm).
2. Field pitch Condensate Drain line a minimum of $1/8"$ (3.2 mm) per foot (305 mm). All units contain a factory installed condensate trap. Do not trap external to the unit. Select appropriate drain system materials. The drain line must comply with all local codes.
3. Supplied on Dual Cooling systems only.
4. When piping out the top of the unit, field must install traps in the discharge lines in the bottom of the unit before running lines to the top.

POINT	DESCRIPTION	X in. (mm)	Y in. (mm)	CONNECTION SIZE / OPENING
R	REFRIGERANT ACCESS	82-3/4 (2102)	13-7/8 (352)	16-7/16" (4181mm) X 4" (102mm)
L1	LIQUID LINE SYSTEM 1	97 (2464)	16-7/8 (429)	5/8" O.D. Cu
L2	LIQUID LINE SYSTEM 2	93-5/16 (2370)		
G1	HOT GAS DISCHARGE 1 ⁴	90-5/8 (2302)	16-5/8 (422)	1-1/8" O.D. Cu
G2	HOT GAS DISCHARGE 2 ⁴	88 (2235)		
CD	CONDENSATE DRAIN ² (infrared humidifier or no humidifier)	68-3/8 (1737)	31-3/8 (797)	3/4" NPT FEMALE
	W/ OPTIONAL PUMP			1/2" O.D. Cu
HUM	HUMIDIFIER SUPPLY LINE	76-1/2 (1943)	29 (737)	1/4" O.D. Cu
ECS	LIEBERT® ECON-O-COIL SUPPLY ³	78-5/8 (1997)	22-1/4 (565)	2-1/8" O.D. Cu
ECR	LIEBERT® ECON-O-COIL RETURN ³	73-15/16 (1862)	26-9/16 (675)	
E1	ELECTRICAL CONN. (HIGH VOLT)	78-1/2 (1994)	31-1/8 (791)	2-1/2"
E2	ELECTRICAL CONN. (HIGH VOLT)	75-3/8 (1915)		
LV1	ELECTRICAL CONN. (LOW VOLT)	2 (51)	29 (737)	7/8"
LV2	ELECTRICAL CONN. (LOW VOLT)		30-7/8 (784)	
LV3	ELECTRICAL CONN. (LOW VOLT)		32 (813)	

PRIMARY CONNECTION LOCATIONS DOWNFLOW AIR COOLED 105kW (30 TONS) ALL COMPRESSOR MODELS

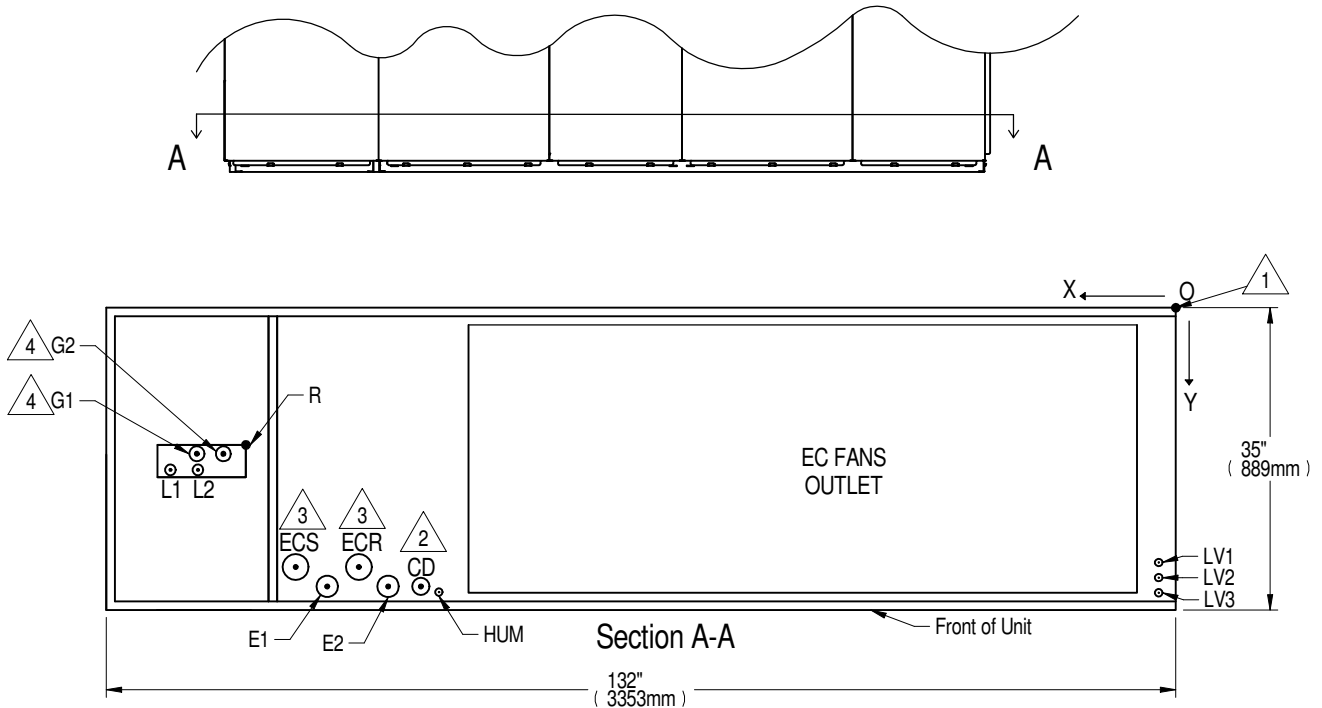

Notes:

1. Drawing not to scale. All dimensions from rear corner of unit including panels, and have a tolerance of $\pm 1/2"$ (13mm).
2. Field pitch Condensate Drain line a minimum of $1/8"$ (3.2 mm) per foot (305 mm). All units contain a factory installed condensate trap. Do not trap external to the unit. Select appropriate drain system materials. The drain line must comply with all local codes.
3. Supplied on Dual Cooling systems only.
4. When piping out the top of the unit, field must install traps in the discharge lines in the bottom of the unit before running lines to the top.

POINT	DESCRIPTION	X in. (mm)	Y in. (mm)	CONNECTION SIZE / OPENING
R	REFRIGERANT ACCESS	109 (2769)	15-3/4 (400)	16-7/16" (418mm) X 4" (102mm)
L1	LIQUID LINE SYSTEM 1	121-3/4 (3092)	16-3/4 (425)	5/8" O.D. Cu
L2	LIQUID LINE SYSTEM 2	118-1/8 (3000)		
G1 ⁴	HOT GAS DISCHARGE 1	118-1/4 (3004)	14-1/4 (362)	1-1/8" O.D. Cu
G2 ⁴	HOT GAS DISCHARGE 2	115-5/8 (2937)		
CD ²	CONDENSATE DRAIN (infrared humidifier or no humidifier)	87-3/8 (2219)	31 (787)	3/4" NPT FEMALE
	W/ OPTIONAL PUMP	83-13/16 (2129)	30 (762)	1/2" O.D. Cu
HUM	HUMIDIFIER SUPPLY LINE	85-5/16 (2167)	32-1/2 (826)	1/4" O.D. Cu
ECS ³	LIEBERT® ECON-O-COIL SUPPLY	101-7/8 (2588)	29 (737)	2-5/8" O.D. Cu
ECR ³	LIEBERT® ECON-O-COIL RETURN	94-9/16 (2402)		
E1	ELECTRICAL CONN. (HIGH VOLT)	98-1/8 (2492)	31 (787)	2-1/2"
E2	ELECTRICAL CONN. (HIGH VOLT)	91 (2311)		
LV1	ELECTRICAL CONN. (LOW VOLT)	2 (51)	29 (737)	7/8"
LV2	ELECTRICAL CONN. (LOW VOLT)		30-7/8 (784)	
LV3	ELECTRICAL CONN. (LOW VOLT)		32 (813)	

PRIMARY CONNECTION LOCATIONS DOWNFLOW WATER/GLYCOL/GLYCOOL 35-42kW (10-12 TONS) ALL COMPRESSOR MODELS

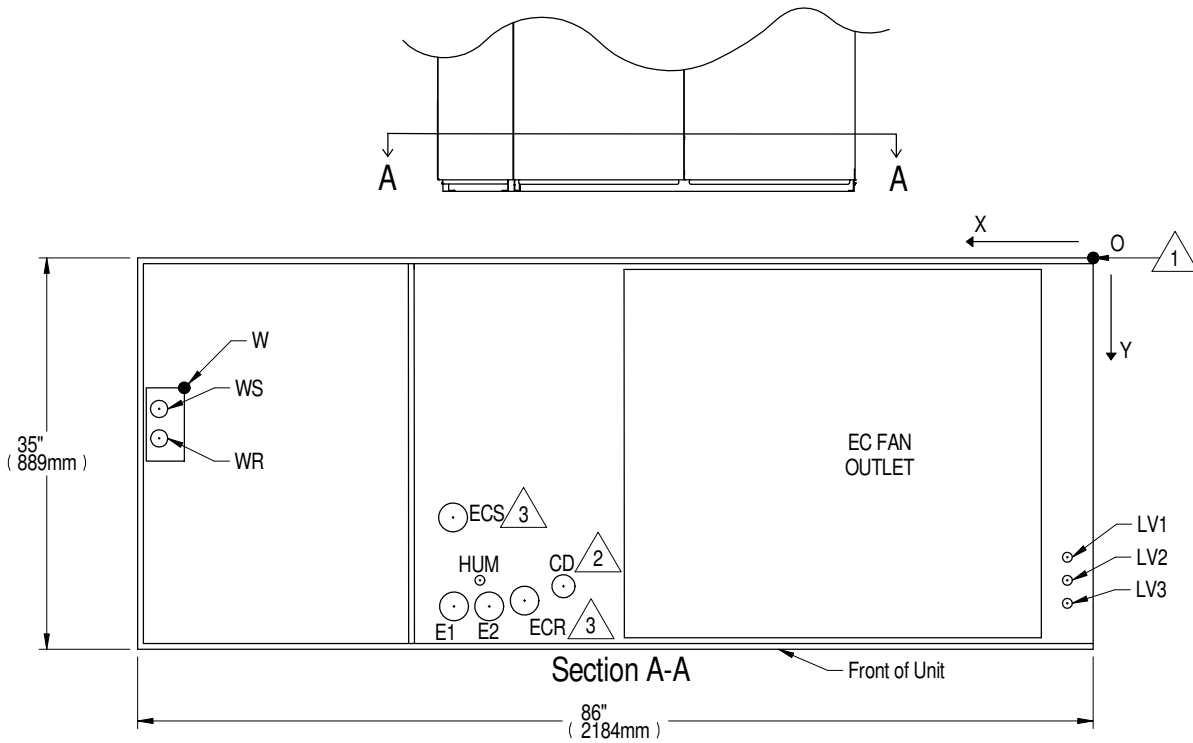

Notes:

1. Drawing not to scale. All dimensions from rear corner of unit including panels, and have a tolerance of $\pm 1/2"$ (13mm).
2. Field pitch Condensate Drain line a minimum of $1/8"$ (3.2 mm) per foot (305 mm). All units contain a factory installed condensate trap. Do not trap external to the unit. Select appropriate drain system materials. The drain line must comply with all local codes.
3. Supplied on Dual Cooling systems only (four-pipe system).
4. Semi-Hermetic Compressor not available on 35kW - 42kW models.

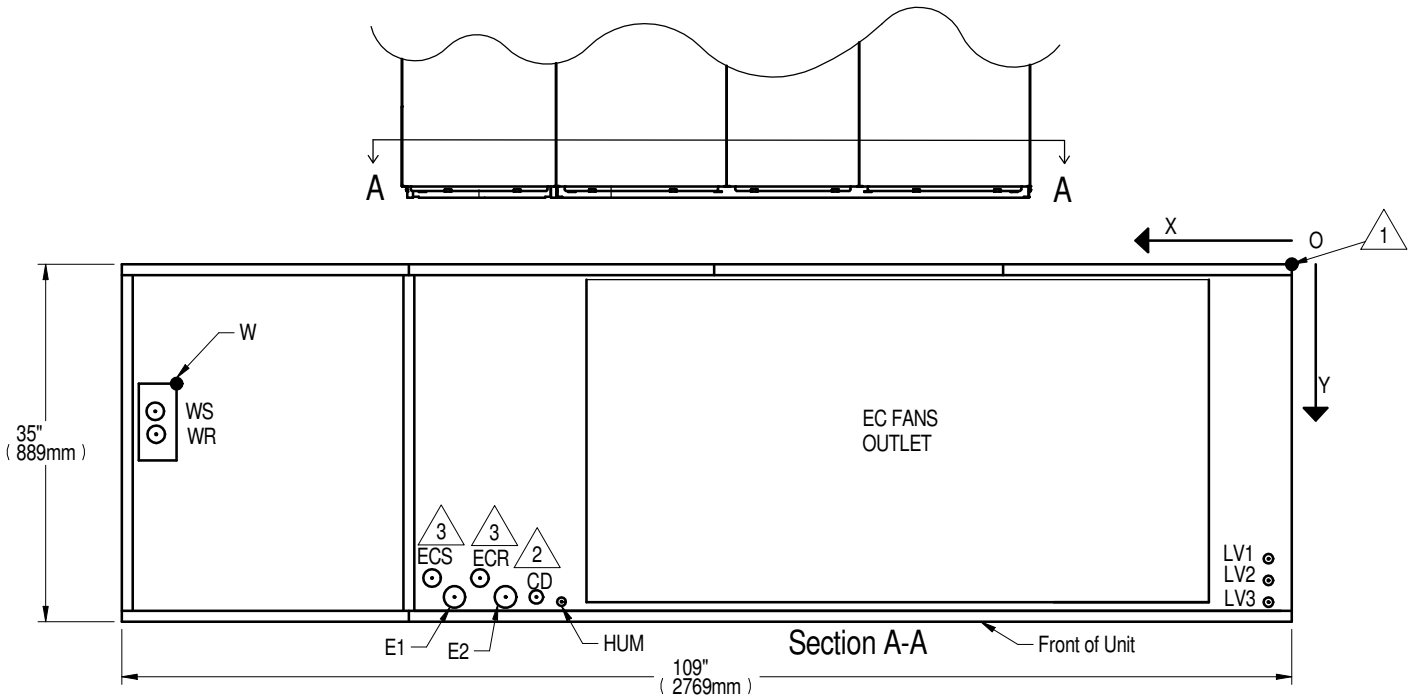

POINT	DESCRIPTION	X in. (mm)	Y in. (mm)	CONNECTION SIZE / OPENING	
				35kW (10 TONS)	42kW (12 TONS)
W	WATER/GLYCOL/GLYCOOL ACCESS	79-15/16 (2030)	9-1/16 (230)	3-1/2" (89mm) X 8" (203mm)	
WS	WATER/GLYCOL/GLYCOOL SUPPLY	82-15/16 (2107)	10-15/16 (278)	1-5/8" O.D. CU 2-1/8" O.D. CU	
WR	WATER/GLYCOL/GLYCOOL RETURN		14-1/16 (357)		
ECS	LIEBERT® ECON-O-COIL SUPPLY ³	54-7/8 (1394)	22-9/16 (573)		
ECR	LIEBERT® ECON-O-COIL RETURN ³	49-13/16 (1265)	28-1/2 (724)		
CD	CONDENSATE DRAIN ² (infrared humidifier or no humidifier)	46 (1168)	29-1/2 (749)	3/4" NPT FEMALE	
	W/ OPTIONAL PUMP			1/2" O.D. Cu	
HUM	HUMIDIFIER SUPPLY LINE	53-1/2 (1359)	29 (737)	1/4" O.D. Cu	
E1	ELECTRICAL CONN. (HIGH VOLT)	55-1/2 (1410)	31-1/4 (794)	2-1/2"	
E2	ELECTRICAL CONN. (HIGH VOLT)	52-7/16 (1332)			
LV1	ELECTRICAL CONN. (LOW VOLT)	2-1/4 (57)	27 (686)	7/8"	
LV2	ELECTRICAL CONN. (LOW VOLT)		29 (737)		
LV3	ELECTRICAL CONN. (LOW VOLT)		31 (787)		

**PRIMARY CONNECTION LOCATIONS
DOWNFLOW WATER/GLYCOL/GLYCOOL™ 53-77kW (15-22 TONS)
ALL COMPRESSOR MODELS**



Notes:

1. Drawing not to scale. All dimensions from rear corner of unit including panels, and have a tolerance of $\pm 1/2"$ (13mm).
2. Field pitch Condensate Drain line a minimum of $1/8"$ (3.2 mm) per foot (305 mm). All units contain a factory installed condensate trap. Do not trap external to the unit. Select appropriate drain system materials. The drain line must comply with all local codes.
3. Supplied on Dual Cooling systems only (four-pipe system).
4. Scroll and Digital Scroll compressors not available on 77kW models.
5. Semi-Hermetic Compressor available only on 77kW models.

POINT	DESCRIPTION	X in. (mm)	Y in. (mm)	CONNECTION SIZE / OPENING
W	WATER/GLYCOL/GLYCOOL ACCESS	103 (2616)	9 (229)	3-1/2" (89mm) X 8 (203mm)
WS	WATER/GLYCOL/GLYCOOL SUPPLY	104-3/4 (2661)	11 (279)	2-1/8" O.D. Cu
WR	WATER/GLYCOL/GLYCOOL RETURN		15 (381)	
CD	CONDENSATE DRAIN 	68-3/8 (1737)	31-3/8 (797)	3/4" NPT FEMALE
	(infrared humidifier or no humidifier) W/ OPTIONAL PUMP			1/2" O.D. Cu
HUM	HUMIDIFIER SUPPLY LINE	76-1/2 (1943)	29 (737)	1/4" O.D. Cu
ECS	LIEBERT® ECON-O-COIL SUPPLY 	78-5/8 (1997)	22-1/4 (565)	2-1/8" O.D. Cu
ECR	LIEBERT® ECON-O-COIL RETURN 	73-15/16 (1878)	26-9/16 (675)	
E1	ELECTRICAL CONN. (HIGH VOLT)	78-1/2 (1994)	31-1/8 (791)	2-1/2"
E2		75-3/8 (1915)		
LV1	ELECTRICAL CONN. (LOW VOLT)	2 (51)	29 (737)	7/8"
LV2			30-7/8 (784)	
LV3			32 (813)	

PRIMARY CONNECTION LOCATIONS DOWNFLOW WATER/GLYCOL/GLYCOOL 105kW (30 TONS) ALL COMPRESSOR MODELS

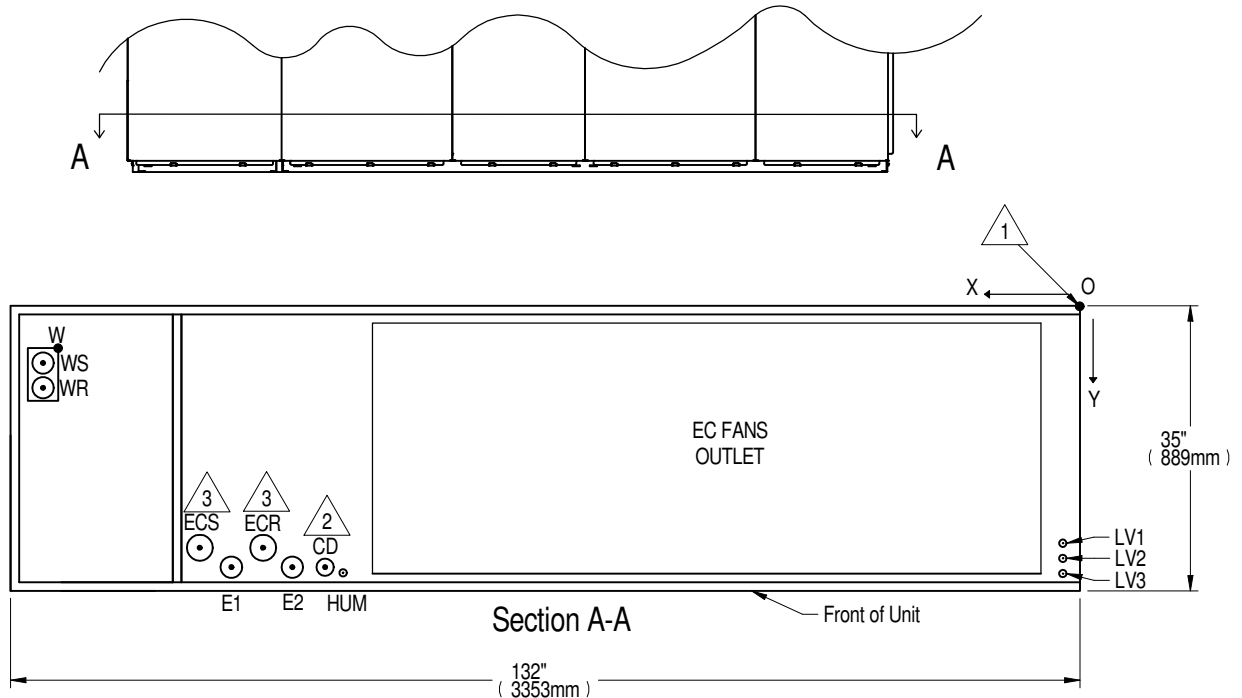

Notes:

1. Drawing not to scale. All dimensions from rear corner of unit including panels, and have a tolerance of $\pm 1/2"$ (13mm).
2. Field pitch Condensate Drain line a minimum of $1/8"$ (3.2 mm) per foot (305 mm). All units contain a factory installed condensate trap. Do not trap external to the unit. Select appropriate drain system materials. The drain line must comply with all local codes.
3. Supplied on Dual Cooling systems only (four-pipe system).
4. Scroll and Digital Scroll compressors not available on 105kW models.

POINT	DESCRIPTION	X in. (mm)	Y in. (mm)	CONNECTION SIZE / OPENING
W	WATER/GLYCOL/GLYCOOL ACCESS	125-15/16 (3199)	9 (229)	3-1/2" (89mm) X 8" (203mm)
WS	WATER/GLYCOL/GLYCOOL SUPPLY	127-7/8 (3248)	10-1/16 (256)	2-1/8" O.D. Cu
WR	WATER/GLYCOL/GLYCOOL RETURN		13-1/4 (337)	
CD ²	CONDENSATE DRAIN (infrared humidifier or no humidifier)	87-3/8 (2219)	31 (787)	3/4" NPT FEMALE
	W/ OPTIONAL PUMP	83-13/16 (2129)	30 (762)	1/2" O.D. Cu
HUM	HUMIDIFIER SUPPLY LINE	85-5/16 (2167)	32-1/2 (826)	1/4" O.D. Cu
ECS ³	LIEBERT® ECON-O-COIL SUPPLY	101-7/8 (2588)	29 (737)	2-5/8" O.D. Cu
ECR ³	LIEBERT® ECON-O-COIL RETURN	94-9/16 (2402)		
E1	ELECTRICAL CONN. (HIGH VOLT)	98-1/8 (2492)	31 (787)	2-1/2"
E2	ELECTRICAL CONN. (HIGH VOLT)	91 (2311)		
LV1	ELECTRICAL CONN. (LOW VOLT)	2 (51)	29 (737)	7/8"
LV2	ELECTRICAL CONN. (LOW VOLT)		30-7/8 (784)	
LV3	ELECTRICAL CONN. (LOW VOLT)		32 (813)	

PRIMARY CONNECTION LOCATIONS UPFLOW AIR COOLED 35-42kW (10-12 TONS) SCROLL OR DIGITAL SCROLL COMPRESSOR MODELS W/ EC FANS

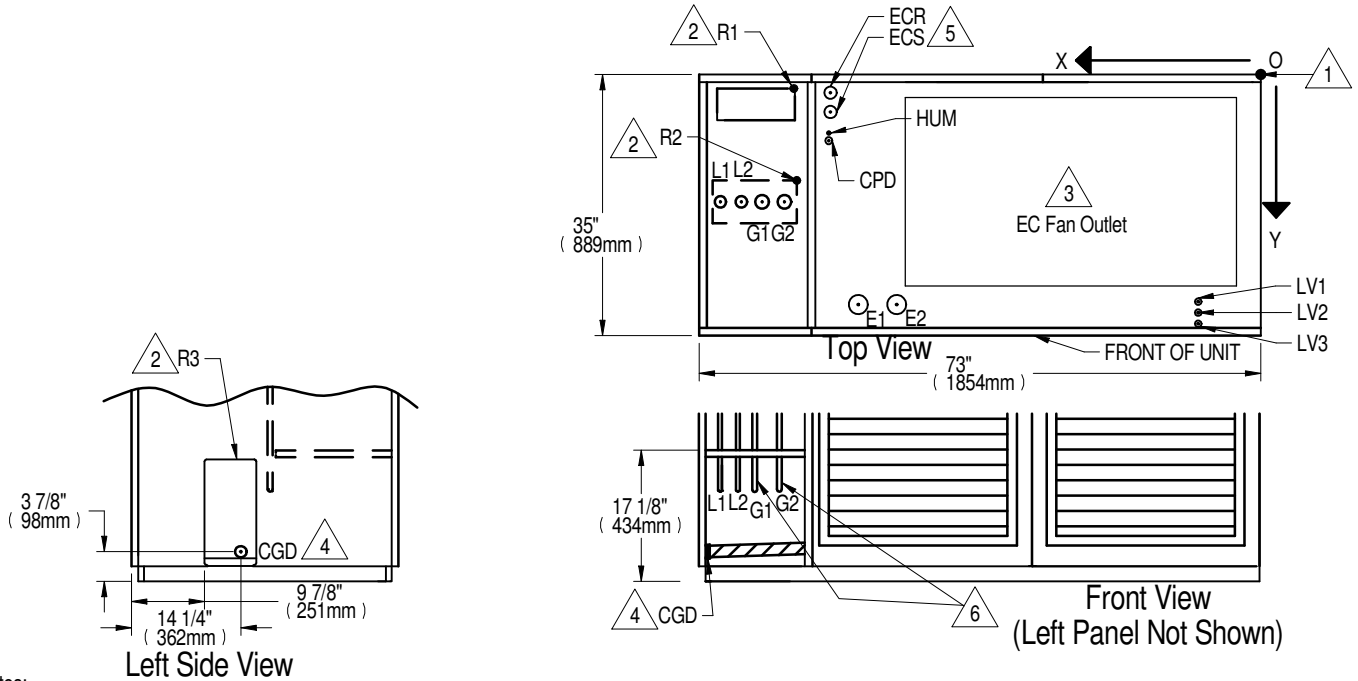

Notes:

- 1. Drawing not to scale. All dimensions from rear corner of unit including panels, and have a tolerance of $\pm 1/2"$ (13mm).
- 2. Field routed alternatives for refrigerant gas & liquid line connection points.
- 3. EC fan shown. See submittal page DPN003458 for EC fan outlet & plenum dimensional data.
- 4. Field pitch Condensate Drain line a minimum of $1/8"$ (3.2 mm) per foot (305 mm). All units contain a factory installed condensate trap. Do not trap external to the unit. Select appropriate drain system materials. The drain line must comply with all local codes.
- 5. Supplied on Dual Cooling Systems only.
- 6. When piping out the top of the unit, field must install traps in the discharge lines in the bottom of the unit before running lines to the top.

POINT	DESCRIPTION	X in. (mm)	Y in. (mm)	CONNECTION SIZE / OPENING
R1	REFRIGERANT ACCESS (TOP)	60-5/8 (1540)	2-13/16 (71)	10-1/8" (257mm) X 4-1/8" (105mm)
R2	REFRIGERANT ACCESS (BOTTOM)	59-5/16 (1507)	14-3/4 (375)	11-3/16" (284mm) X 4" (102mm)
R3	REFRIGERANT ACCESS (SIDE)	N/A	N/A	6" (152mm) X 17-3/16" (437mm)
L1	LIQUID LINE SYSTEM 1	69-15/16 (1776)	16-3/4 (425)	1/2" O.D. Cu
L2	LIQUID LINE SYSTEM 2	67-5/8 (1718)		
G1	HOT GAS DISCHARGE 1	65-1/2 (1664)	16-5/8 (422)	5/8" O.D. Cu
G2	HOT GAS DISCHARGE 2	62-7/16 (1586)		
CGD	CONDENSATE GRAVITY DRAIN	N/A	N/A	3/4" NPT FEMALE
CPD	CONDENSATE PUMP DISCHARGE (OPT)	56-1/4 (1429)	11-1/8 (283)	1/2" O.D. Cu
HUM	HUMIDIFIER SUPPLY LINE		9-1/8 (232)	1/4" O.D. Cu
ECS	LIEBERT® ECON-O-COIL SUPPLY	56 (1422)	7-5/16 (186)	1-5/8" O.D. Cu
ECR	LIEBERT® ECON-O-COIL RETURN		4-1/2 (114)	
E1	ELECTRICAL CONN. (HIGH VOLT)	52-3/8 (1330)	29-15/16 (760)	2-1/2"
E2		47-3/8 (1203)		
LV1	ELECTRICAL CONN. (LOW VOLT)	8-1/8 (206)	29-9/16 (751)	7/8"
LV2			31 (787)	
LV3			32-7/16 (824)	

PRIMARY CONNECTION LOCATIONS UPFLOW AIR COOLED 77kW (22 TONS) SEMI-HERMETIC COMPRESSOR MODELS W/ EC FANS

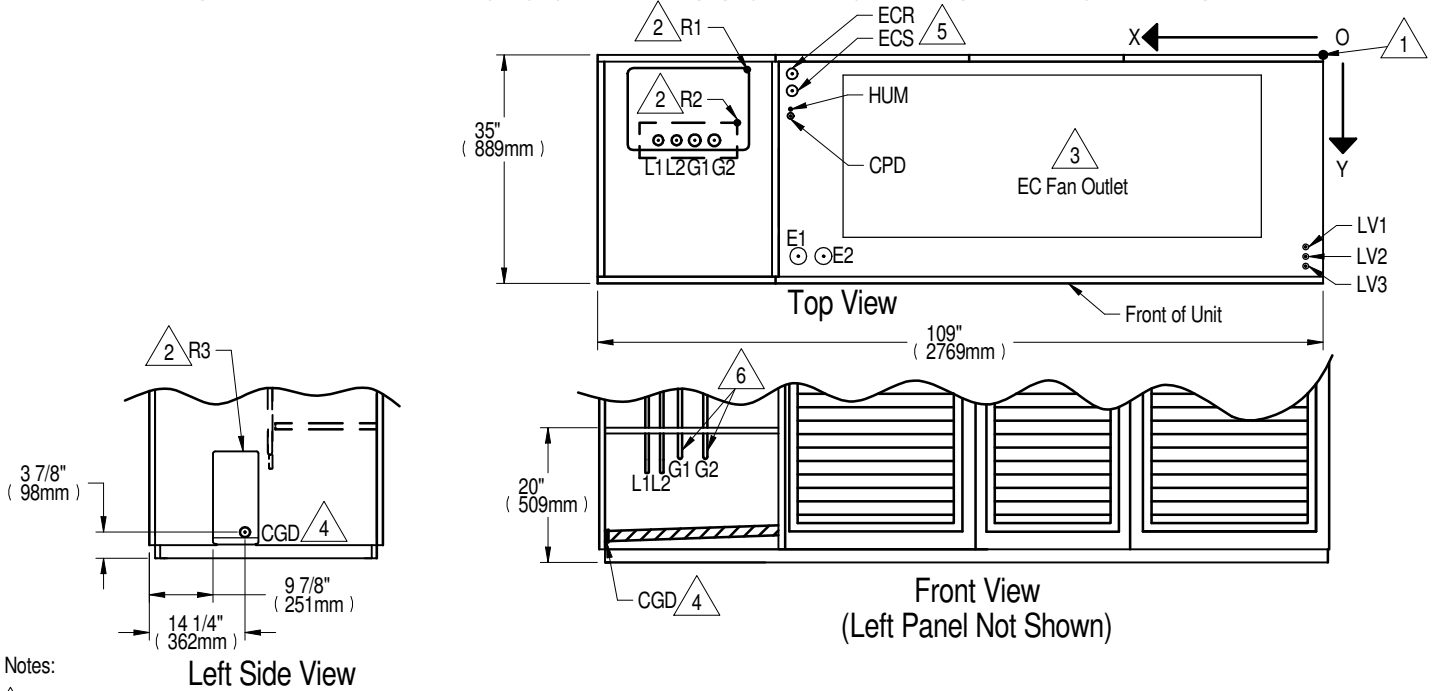

Notes:

1. Drawing not to scale. All dimensions from rear corner of unit including panels, and have a tolerance of $\pm 1/2"$ (13mm).
2. Field routed alternatives for refrigerant gas & liquid line connection points.
3. EC fans shown. See submittal page DPN003453 for EC fan outlet and plenum dimensional data.
4. Field pitch Condensate Drain line a minimum of $1/8"$ (3.2 mm) per foot (305 mm). All units contain a factory installed condensate trap. Do not trap external to the unit. Select appropriate drain system materials. The drain line must comply with all local codes.
5. Supplied on Dual Cooling Systems only.
6. When piping out the top of the unit, field must install traps in the discharge lines in the bottom of the unit before running lines to the top.

POINT	DESCRIPTION	X in. (mm)	Y in. (mm)	CONNECTION SIZE / OPENING
R1	REFRIGERANT ACCESS (TOP)	83-3/4 (2127)	1-7/8 (48)	22-1/2"(572mm) X 15-3/16" (386mm)
R2	REFRIGERANT ACCESS (BOTTOM)	86 (2184)	13-7/8 (352)	16-7/16" (418mm) X 4" (102mm)
R3	REFRIGERANT ACCESS (SIDE)	N/A	N/A	6" (152mm) X 17-3/16" (437mm)
L1	LIQUID LINE SYSTEM 1	97 (2464)	16-3/4 (425)	5/8" O.D. Cu
L2	LIQUID LINE SYSTEM 2	93-5/16 (2370)		
G1	HOT GAS DISCHARGE 1	90-5/8 (2302)	16-5/8 (422)	1-1/8" O.D. Cu
G2	HOT GAS DISCHARGE 2	88 (2235)		
CGD	CONDENSATE GRAVITY DRAIN	N/A	N/A	3/4" NPT FEMALE
CPD	CONDENSATE PUMP DISCHARGE (OPT)	79-5/16 (2015)	11-7/8 (302)	1/2" O.D. Cu
HUM	HUMIDIFIER SUPPLY LINE		9-7/8 (251)	1/4" O.D. Cu
ECS	LIEBERT® ECON-O-COIL SUPPLY	78-5/8 (1997)	7-7/8 (200)	2-1/8" O.D. Cu
ECR	LIEBERT® ECON-O-COIL RETURN		4-5/8 (117)	
E1	ELECTRICAL CONN. (HIGH VOLT)	78-1/8 (1984)	30 (762)	2-1/2"
E2	ELECTRICAL CONN. (HIGH VOLT)	74-3/8 (1889)		
LV1	ELECTRICAL CONN. (LOW VOLT)	2-5/8 (67)	28-9/16 (725)	7/8"
LV2	ELECTRICAL CONN. (LOW VOLT)		30 (762)	
LV3	ELECTRICAL CONN. (LOW VOLT)		31-7/16 (799)	

PRIMARY CONNECTION LOCATIONS UPFLOW AIR COOLED 53-77kW (15-22 TONS) SCROLL OR DIGITAL SCROLL COMPRESSOR MODELS

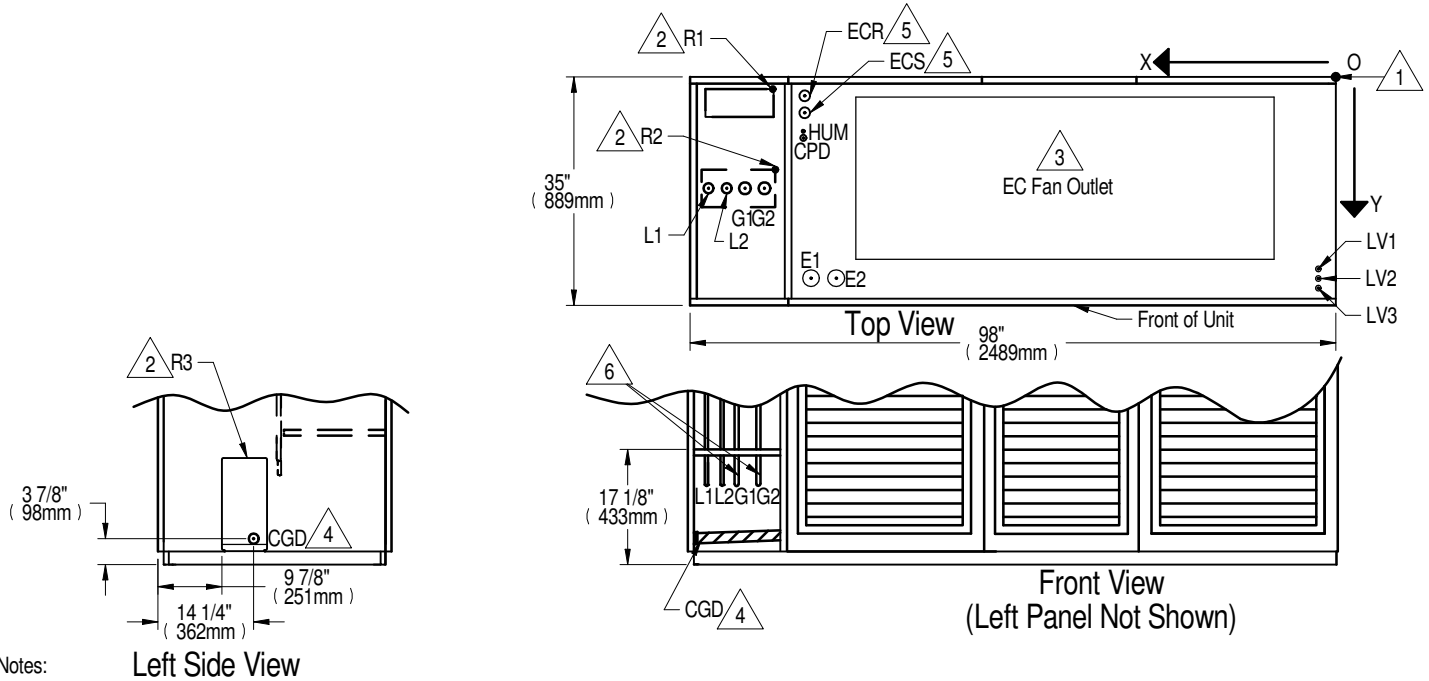

Notes:

Left Side View

1. Drawing not to scale. All dimensions from rear corner of unit including panels, and have a tolerance of $\pm 1/2"$ (13mm).
2. Field routed alternatives for refrigerant gas and liquid line connection points.
3. EC fans shown. See submittal page DPN003453 for EC fan outlet and plenum dimensional data.
4. Field pitch Condensate Drain line a minimum of 1/8" (3.2 mm) per foot (305 mm). All units contain a factory installed condensate trap. Do not trap external to the unit. Select appropriate drain system materials. The drain line must comply with all local codes.
5. Supplied on Dual Cooling Systems only.
6. When piping out the top of the unit, field must install traps in the discharge lines in the bottom of the unit before running lines to the top.
7. Digital Scroll compressor not available on DS077 models.

POINT	DESCRIPTION	X in. (mm)	Y in. (mm)	CONNECTION SIZE / OPENING	
R1	REFRIGERANT ACCESS (TOP)	83-5/8 (2124)	2 (51)	12"(305mm) X 4" (102mm)	
R2	REFRIGERANT ACCESS (BOTTOM)	82-3/4 (2102)	14-3/4 (375)	12-3/16" (310mm) X 4" (102mm)	
R3	REFRIGERANT ACCESS (SIDE)	N/A	N/A	6" (152mm) X 17-3/16" (437mm)	
				53kW (15T ONS)	70 & 77kW (20 & 22T ONS)
L1	LIQUID LINE SYSTEM 1	94-11/16 (2405)	16-3/4 (425)	1/2" O.D. Cu	5/8" O.D. Cu
L2	LIQUID LINE SYSTEM 2	91-7/8 (2334)			
G1	HOT GAS DISCHARGE 1	88-3/4 (2254)	16-3/8 (416)	7/8" O.D. Cu	1-1/8" O.D. Cu
G2	HOT GAS DISCHARGE 2	85-9/16 (2173)			
CGD	CONDENSATE GRAVITY DRAIN	N/A	N/A	3/4" NPT FEMALE	
CPD	CONDENSATE PUMP DISCHARGE (OPT)	79-5/16 (2015)	11-7/8 (302)	1/2" O.D. Cu	
HUM	HUMIDIFIER SUPPLYLINE		9-7/8 (251)	1/4" O.D. Cu	
ECS	LIEBERT® ECON-O-COIL SUPPLY	78-5/8 (1997)	7-7/8 (200)	2-1/8" O.D. Cu	
ECR	LIEBERT® ECON-O-COIL RETURN		4-5/8 (117)		
E1	ELECTRICAL CONN. (HIGH VOLT)	78-1/8 (1984)	30 (762)	2-1/2"	
E2	ELECTRICAL CONN. (HIGH VOLT)	74-3/8 (1889)			
LV1	ELECTRICAL CONN. (LOW VOLT)	2-5/8 (67)	28-9/16 (725)	7/8"	
LV2	ELECTRICAL CONN. (LOW VOLT)		30 (762)		
LV3	ELECTRICAL CONN. (LOW VOLT)		31-7/16 (799)		

PRIMARY CONNECTION LOCATIONS UPFLOW AIR COOLED 105kW (30 TONS) ALL COMPRESSOR MODELS

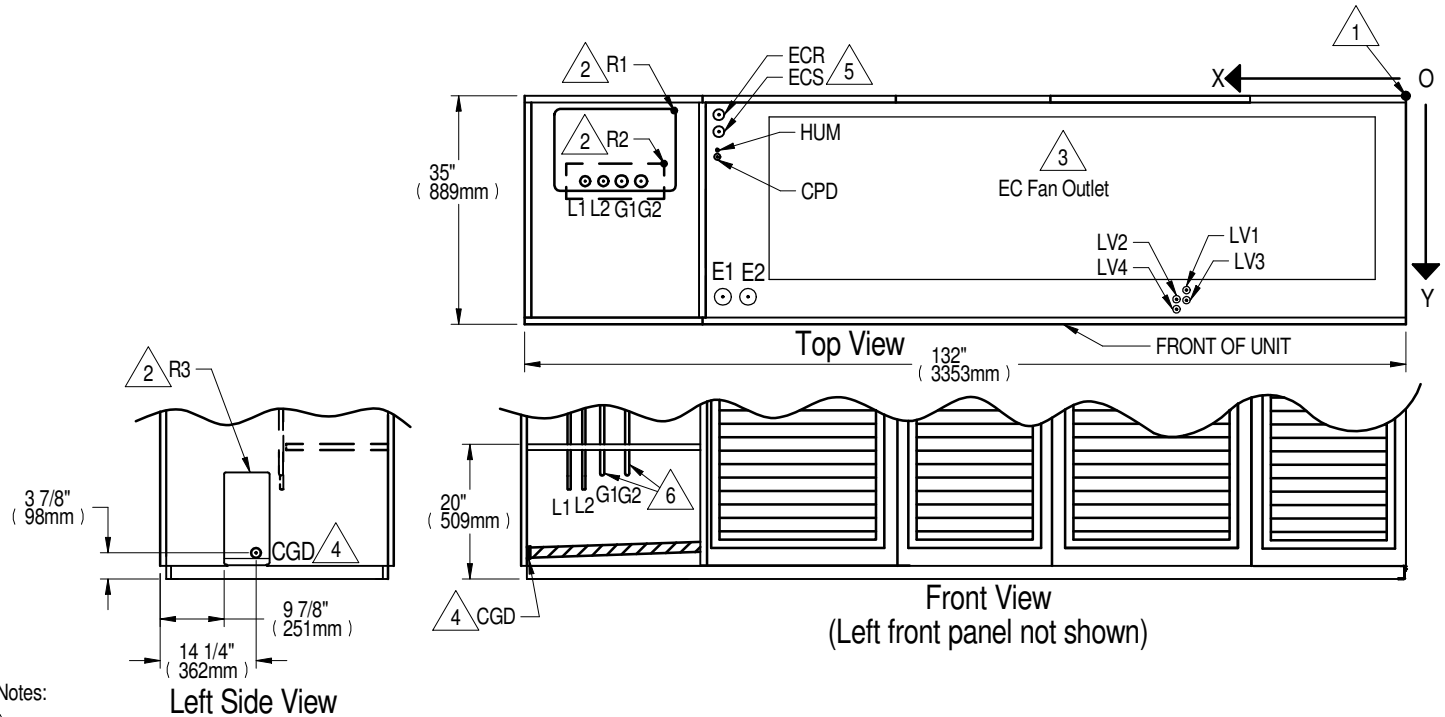

Notes:

1. Drawing not to scale. All dimensions from rear corner of unit including panels, and have a tolerance of $\pm 1/2"$ (13mm).
2. Field routed alternatives for refrigerant gas and liquid line connection points.
3. EC fans shown. See submittal page DPN003459 for EC fan outlet and plenum dimensional data.
4. Field pitch Condensate Drain line a minimum of 1/8" (3.2 mm) per foot (305 mm). All units contain a factory installed condensate trap. Do not trap external to the unit. Select appropriate drain system materials. The drain line must comply with all local codes.
5. Supplied on Dual Cooling Systems only.
6. When piping out the top of the unit, field must install traps in the discharge lines in the bottom of the unit before running lines to the top.
7. Digital Scroll Compressor not available on DS105.





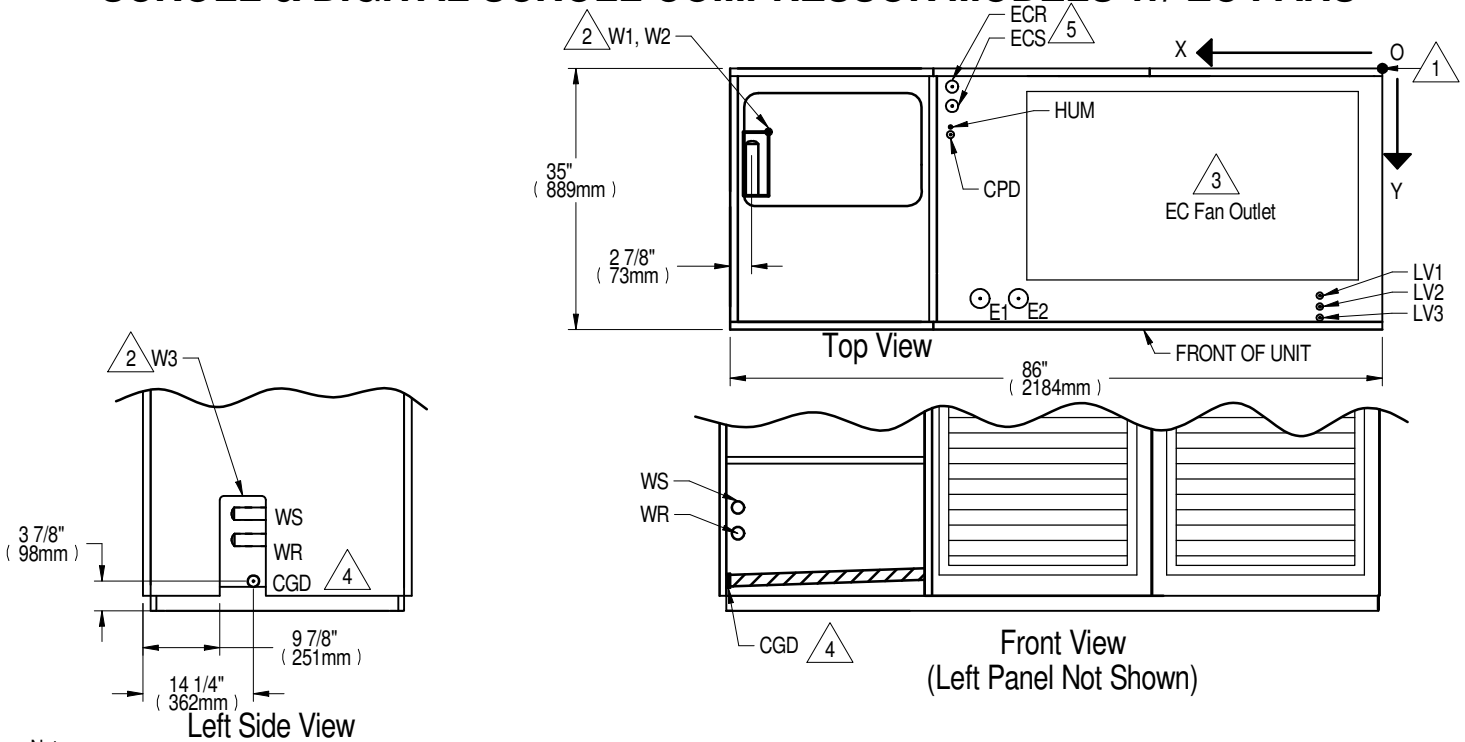

POINT	DESCRIPTION	X in. (mm)	Y in. (mm)	CONNECTION SIZE / OPENING
R1	REFRIGERANT ACCESS (TOP)	106-7/8 (2715)	1-7/8 (48)	22-1/2"(572mm) X 15-3/16" (386mm)
R2	REFRIGERANT ACCESS (BOTTOM)	109-1/8 (2772)	13-7/8 (352)	16-7/16" (418mm) X 4" (102mm)
R3	REFRIGERANT ACCESS (SIDE)	N/A	N/A	6" (152mm) X 17-3/16" (437mm)
L1	LIQUID LINE SYSTEM 1	121-3/4 (3092)	16-3/4 (425)	5/8" O.D. Cu
L2	LIQUID LINE SYSTEM 2	118-1/8 (3000)		
G1	HOT GAS DISCHARGE 1	118-1/4 (3004)	14-1/4 (362)	1-1/8" O.D. Cu
G2	HOT GAS DISCHARGE 2	115-5/8 (2937)		
CGD	CONDENSATE GRAVITY DRAIN	N/A	N/A	3/4" NPT FEMALE
CPD	CONDENSATE PUMP DISCHARGE (OPT)	102-3/8 (2600)	13-5/8 (346)	1/2" O.D. Cu
HUM	HUMIDIFIER SUPPLY LINE	101-1/8 (2569)	13-1/8 (333)	1/4" O.D. Cu
ECS	LIEBERT® ECON-O-COIL SUPPLY		10-1/4 (260)	2-5/8" O.D. Cu
ECR	LIEBERT® ECON-O-COIL RETURN		5-1/4 (133)	
E1	ELECTRICAL CONN. (HIGH VOLT)	97-7/8 (2486)	30 (762)	2-1/2"
E2				
LV1	ELECTRICAL CONN. (LOW VOLT)	34-1/8 (867)	30-1/4 (768)	7/8"
LV2			31-3/4 (806)	
LV3			28-15/16 (735)	
LV4			30-7/16 (773)	

PRIMARY CONNECTION LOCATIONS UPFLOW WATER/GLYCOL/GLYCOOL 35-42kW (10-12 TONS) SCROLL & DIGITAL SCROLL COMPRESSOR MODELS W/ EC FANS



Notes:

1. Drawing not to scale. All dimensions from rear corner of unit including panels, and have a tolerance of $\pm 1/2"$ (13mm).
2. Field routed alternatives for water/glycol connections.
3. EC fan shown. See submittal page DPN003458 for EC fan outlet and plenum dimensional data.
4. Field pitch Condensate Drain line a minimum of $1/8"$ (3.2 mm) per foot (305 mm). All units contain a factory installed condensate trap. Do not trap external to the unit. Select appropriate drain system materials. The drain line must comply with all local codes.
5. Supplied on Dual Cooling Systems only (four-pipe systems).

POINT	DESCRIPTION	X in. (mm)	Y in. (mm)	CONNECTION SIZE / OPENING	
				35kW (10 TONS)	42kW (12 TONS)
W1	WATER/GLYCOL/GLYCOOL ACCESS (BOTTOM) 	79-15/16 (2030)	9 (229)	3-1/2" (89mm) X 8" (203mm)	
W2	WATER/GLYCOL/GLYCOOL ACCESS (TOP) 			6" (152mm) x 17-3/16" (437mm)	
W3	WATER/GLYCOL/GLYCOOL ACCESS (SIDE) 				
WS	WATER/GLYCOL/GLYCOOL SUPPLY	N/A	N/A	1-5/8" O.D. Cu	2-1/8" O.D. Cu
WR	WATER/GLYCOL/GLYCOOL RETURN				
ECS	LIEBERT® ECON-O-COIL SUPPLY 	56 (1422)	7-5/16 (186)	3/4" NPT FEMALE	
ECR	LIEBERT® ECON-O-COIL RETURN 		4-1/2 (114)		
CGD	CONDENSATE GRAVITY DRAIN 	N/A	N/A		
CPD	CONDENSATE PUMP DISCHARGE (OPT)	56-1/4 (1429)	11-1/8 (283)	1/2" O.D. Cu	
HUM	HUMIDIFIER SUPPLY LINE		9-1/8 (232)	1/4" O.D. Cu	
E1	ELECTRICAL CONN. (HIGH VOLT)	52-3/8 (1330)	29-15/16 (760)	2-1/2"	
E2		47-3/8 (1203)			
LV1	ELECTRICAL CONN. (LOW VOLT)	8-1/8 (206)	29-9/16 (751)	7/8"	
LV2			31 (787)		
LV3			32-7/16 (824)		

PRIMARY CONNECTION LOCATIONS UPFLOW WATER/GLYCOL/GLYCOOL 53-77kW (15-22 TONS) ALL COMPRESSOR MODELS W/ EC FANS

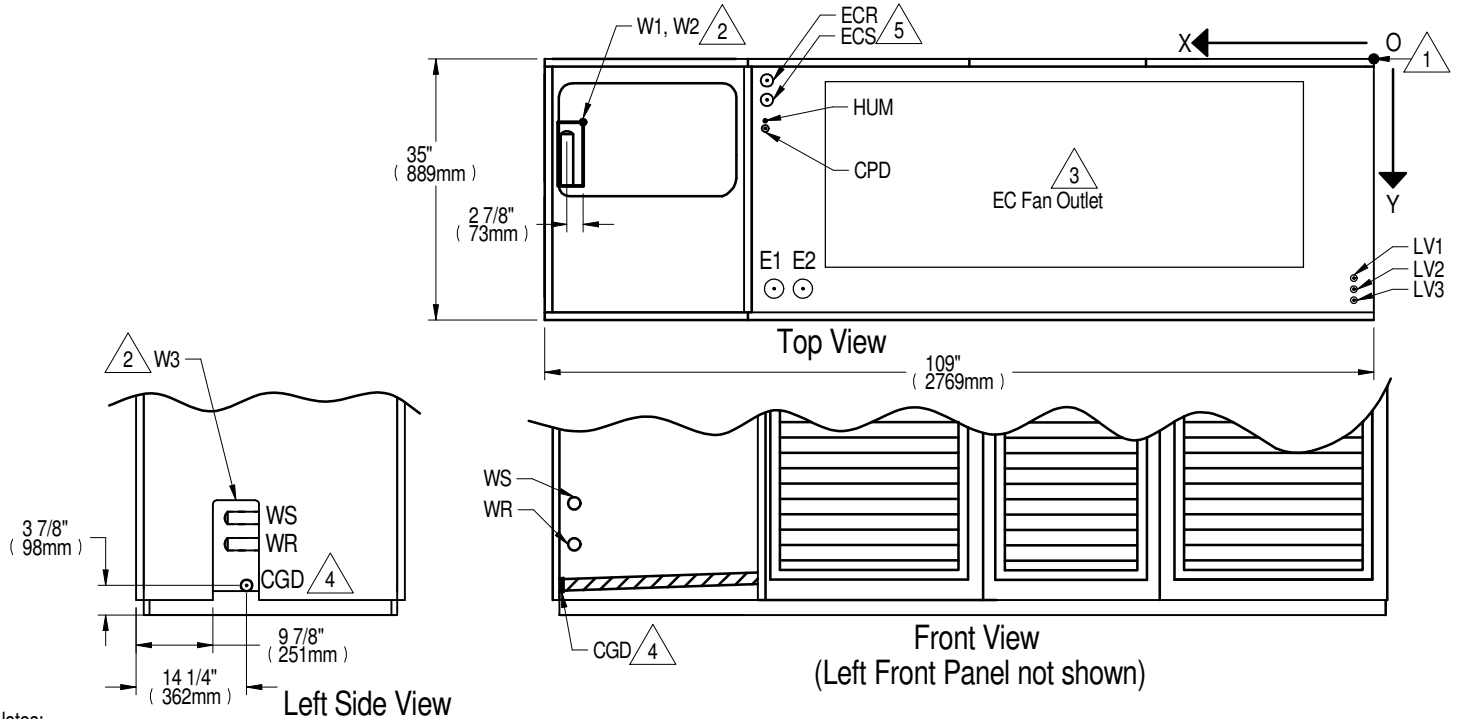

Notes:

1. Drawing not to scale. All dimensions from rear corner of unit including panels, and have a tolerance of $\pm 1/2"$ (13mm).
2. Field routed alternatives for water/glycol connections.
3. EC fan shown. See submittal DPN003453 for EC fan outlet & plenum dimensional data.
4. Field pitch Condensate Drain line a minimum of $1/8"$ (3.2 mm) per foot (305 mm). All units contain a factory installed condensate trap. Do not trap external to the unit. Select appropriate drain system materials. The drain line must comply with all local codes.
5. Supplied on Dual Cooling Systems only (four-pipe system).
6. Scroll and Digital Scroll compressor not available on 77kW models.
7. Semi-Hermetic Compressor only available on 77kW models.





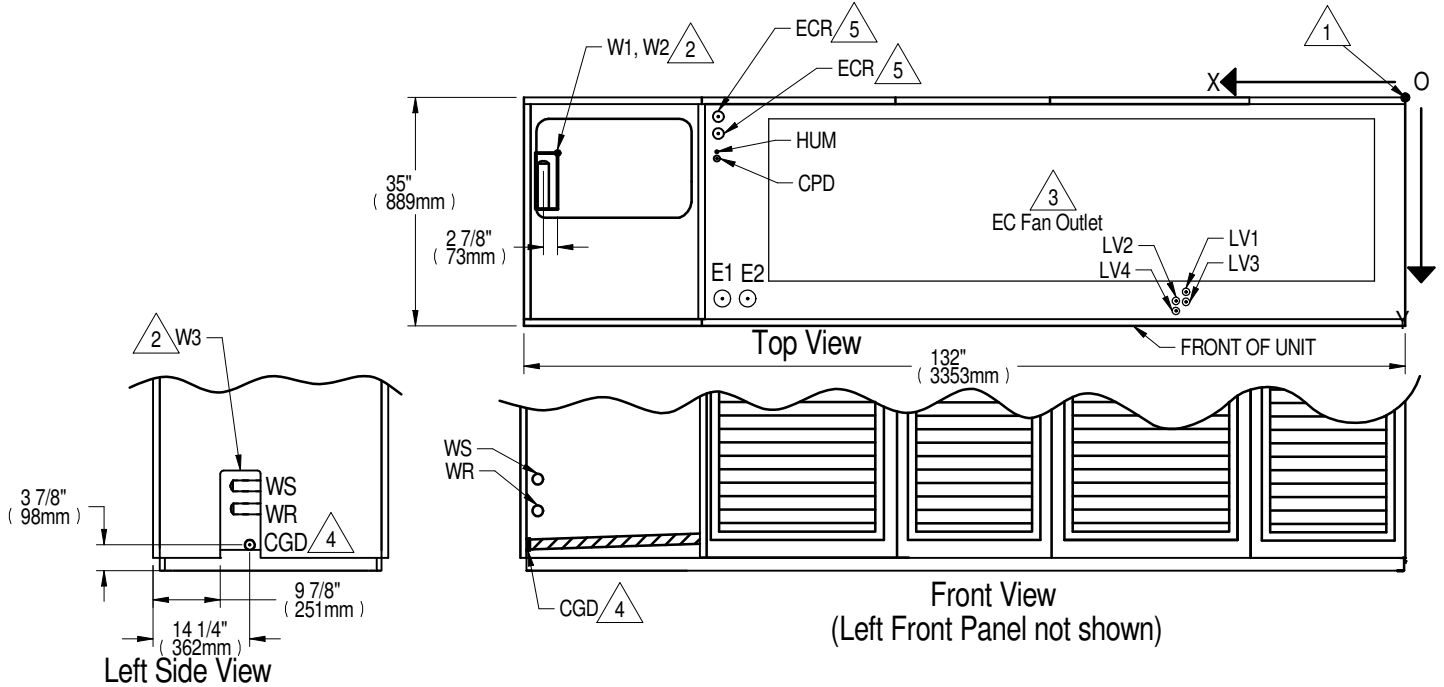

POINT	DESCRIPTION	X in. (mm)	Y in. (mm)	CONNECTION SIZE / OPENING
W1	WATER/GLYCOL/GLYCOOL ACCESS (BOTTOM) ²	102-15/16 (2615)	9 (229)	3-1/2" (89mm) X 8" (203mm)
W2	WATER/GLYCOL/GLYCOOL ACCESS (TOP) ²			3-1/2" (89mm) X 8" (203mm)
W3	WATER/GLYCOL/GLYCOOL ACCESS (SIDE) ²	N/A	N/A	6" (152mm) x 17-3/16" (437mm)
WS	WATER/GLYCOL/GLYCOOL SUPPLY			2-1/8" O.D. Cu
WR	WATER/GLYCOL/GLYCOOL RETURN			3/4" NPT FEMALE
CGD	CONDENSATE GRAVITY DRAIN ⁴			
CPD	CONDENSATE PUMP DISCHARGE (OPT)	79-5/16 (2015)	11-7/8 (302)	1/2" O.D. Cu
HUM	HUMIDIFIER SUPPLY LINE		9-7/8 (251)	1/4" O.D. Cu
ECS	LIEBERT® ECON-O-COIL SUPPLY ⁵	78-5/8 (1998)	7-7/8 (200)	2-1/8" O.D. Cu
ECR	LIEBERT® ECON-O-COIL RETURN ⁵		4-5/8 (117)	
E1	ELECTRICAL CONN. (HIGH VOLT)	78-1/8 (1984)	30 (762)	2-1/2"
E2	ELECTRICAL CONN. (HIGH VOLT)	74-3/8 (1889)		
LV1	ELECTRICAL CONN. (LOW VOLT)	2-5/8 (66)	28-9/16 (726)	7/8"
LV2	ELECTRICAL CONN. (LOW VOLT)		30 (762)	
LV3	ELECTRICAL CONN. (LOW VOLT)		31-7/16 (799)	

PRIMARY CONNECTION LOCATIONS UPFLOW WATER/GLYCOL/GLYCOOL 105kW (30 TONS) ALL COMPRESSOR MODELS



Notes:

1. Drawing not to scale. All dimensions from rear corner of unit including panels, and have a tolerance of $\pm 1/2"$ (13mm).
2. Field routed alternatives for water/glycol connections.
3. EC fans shown. See submittal DPN003459 for EC fan outlet & plenum dimensional data.
4. Field pitch Condensate Drain line a minimum of $1/8"$ (3.2 mm) per foot (305 mm). All units contain a factory installed condensate trap. Do not trap external to the unit. Select appropriate drain system materials. The drain line must comply with all local codes.
5. Supplied on Dual Cooling Systems only (four-pipe system).
6. Scroll and Digital Scroll compressor not available on 105kW models.

POINT	DESCRIPTION	X in. (mm)	Y in. (mm)	CONNECTION SIZE / OPENING
W1	WATER/GLYCOL/GLYCOOL ACCESS (BOTTOM) 	126-1/8 (3204)	9 (229)	3-1/2" (89mm) X 8" (203mm)
W2	WATER/GLYCOL/GLYCOOL ACCESS (TOP) 			3-1/2" (89mm) X 8" (203mm)
W3	WATER/GLYCOL/GLYCOOL ACCESS (SIDE) 			6" (152mm) x 17-3/16" (437mm)
WS	WATER/GLYCOL/GLYCOOL SUPPLY	N/A	N/A	2-1/8" O.D. Cu
WR	WATER/GLYCOL/GLYCOOL RETURN			
CGD	CONDENSATE GRAVITY DRAIN 			3/4" NPT FEMALE
CPD	CONDENSATE PUMP DISCHARGE (OPT)	102-3/8 (2600)	13-5/8 (346)	1/2" O.D. Cu
HUM	HUMIDIFIER SUPPLY LINE		13-1/8 (333)	1/4" O.D. Cu
ECS	LIEBERT® ECON-O-COIL SUPPLY 	101-1/8 (2569)	10-1/4 (260)	2-5/8" O.D. Cu
ECR	LIEBERT® ECON-O-COIL RETURN 		5-1/4 (133)	
E1	ELECTRICAL CONN. (HIGH VOLT)	101-5/8 (2581)	30 (762)	2-1/2"
E2		97-7/8 (2486)		
LV1	ELECTRICAL CONN. (LOW VOLT)	34-1/8 (867)	30-1/4 (768)	7/8"
LV2			31-3/4 (806)	
LV3			28-15/16 (735)	
LV4			30-7/16 (773)	

PRIMARY CONNECTION LOCATIONS

UPFLOW AIR COOLED 35-42kW (10-12 TONS) SCROLL OR DIGITAL SCROLL COMPRESSOR MODELS W/ FORWARD CURVED BLOWERS

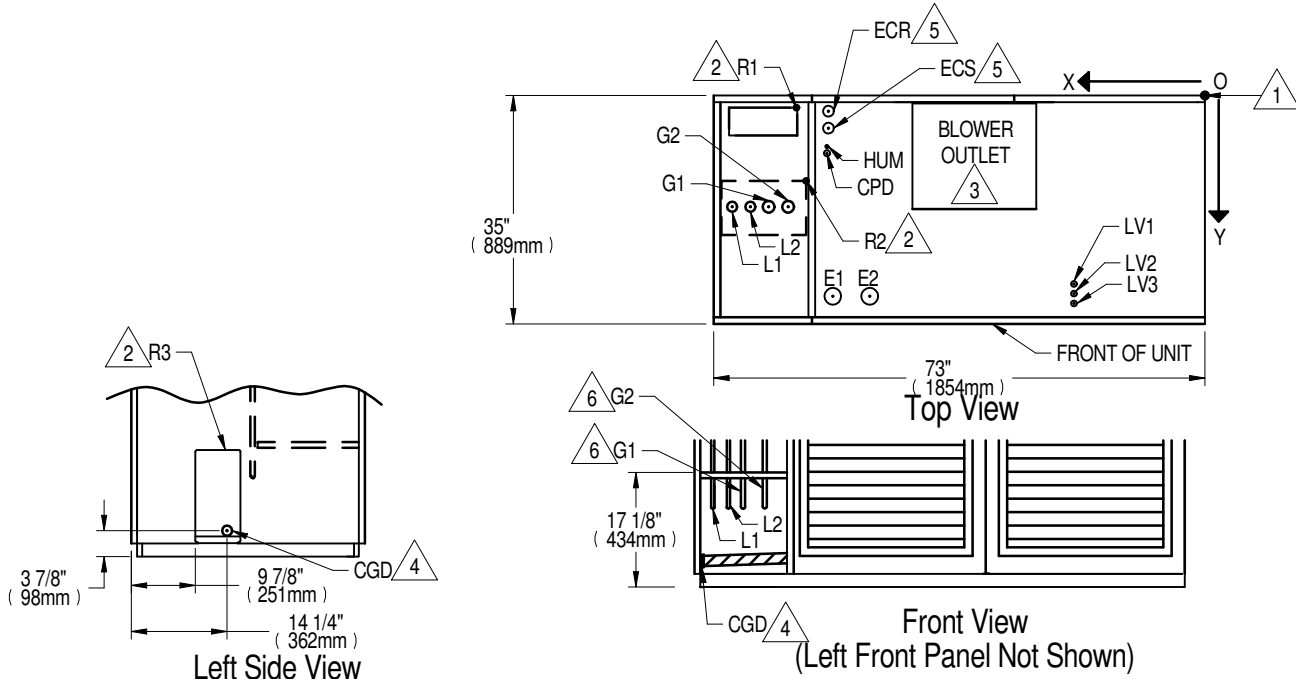

Notes:

1. Drawing not to scale. All dimensions from rear corner of unit including panels, and have a tolerance of $\pm 1/2"$ (13mm).
2. Field routed alternatives for refrigerant gas & liquid line connection points.
3. Forward Curved Blower Shown. See submittal page DPN001120 for blower outlet and deck dimensional data.
4. Field pitch Condensate Drain line a minimum of $1/8"$ (3.2 mm) per foot (305 mm). All units contain a factory installed condensate trap. Do not trap external to the unit. Select appropriate drain system materials. The drain line must comply with all local codes.
5. Supplied on Dual Cooling Systems only.
6. When piping out of the top of the unit, field must install traps in the discharge lines in the bottom of the unit before running lines to the top.

7. Digital Scroll compressors not available on Air Cooled 42kW models.

POINT	DESCRIPTION	X in. (mm)	Y in. (mm)	CONNECTION SIZE / OPENING
R1	REFRIGERANT ACCESS (TOP)	60-5/8 (1540)	2-13/16 (71)	10-1/8" (257mm) X 4-1/8" (105mm)
R2	REFRIGERANT ACCESS (BOTTOM)	59-5/16 (1507)	14-3/4 (375)	11-3/16" (284mm) X 4" (102mm)
R3	REFRIGERANT ACCESS (SIDE)	N/A	N/A	6" (152mm) X 17-3/16" (437mm)
L1	LIQUID LINE SYSTEM 1	69-15/16 (1776)	16-3/4 (425)	1/2" O.D. Cu
L2	LIQUID LINE SYSTEM 2	67-5/8 (1718)		
G1	HOT GAS DISCHARGE 1	65-1/2 (1664)	16-5/8 (422)	5/8" O.D. Cu
G2	HOT GAS DISCHARGE 2	62-7/16 (1586)		
CGD	CONDENSATE GRAVITY DRAIN	N/A	N/A	3/4" NPT FEMALE
CPD	CONDENSATE PUMP DISCHARGE (OPT)	56-1/4 (1429)	11-1/8 (283)	1/2" O.D. Cu
HUM	HUMIDIFIER SUPPLY LINE		9-1/8 (232)	1/4" O.D. Cu
ECS	LIEBERT® ECON-O-COIL SUPPLY		56 (1422)	7-5/16 (186)
ECR	LIEBERT® ECON-O-COIL RETURN	4-1/2 (114)		
E1	ELECTRICAL CONN. (HIGH VOLT)	52-3/8 (1330)	30 (762)	2-1/2"
E2	ELECTRICAL CONN. (HIGH VOLT)	46-7/8 (1191)		
LV1	ELECTRICAL CONN. (LOW VOLT)	19-1/2 (495)	29-1/16 (738)	7/8"
LV2	ELECTRICAL CONN. (LOW VOLT)		30-1/2 (775)	
LV3	ELECTRICAL CONN. (LOW VOLT)		31-15/16 (811)	

PRIMARY CONNECTION LOCATIONS UPFLOW AIR COOLED 77kW (22 TONS) SEMI-HERMETIC COMPRESSOR MODELS W/ FORWARD CURVED BLOWERS

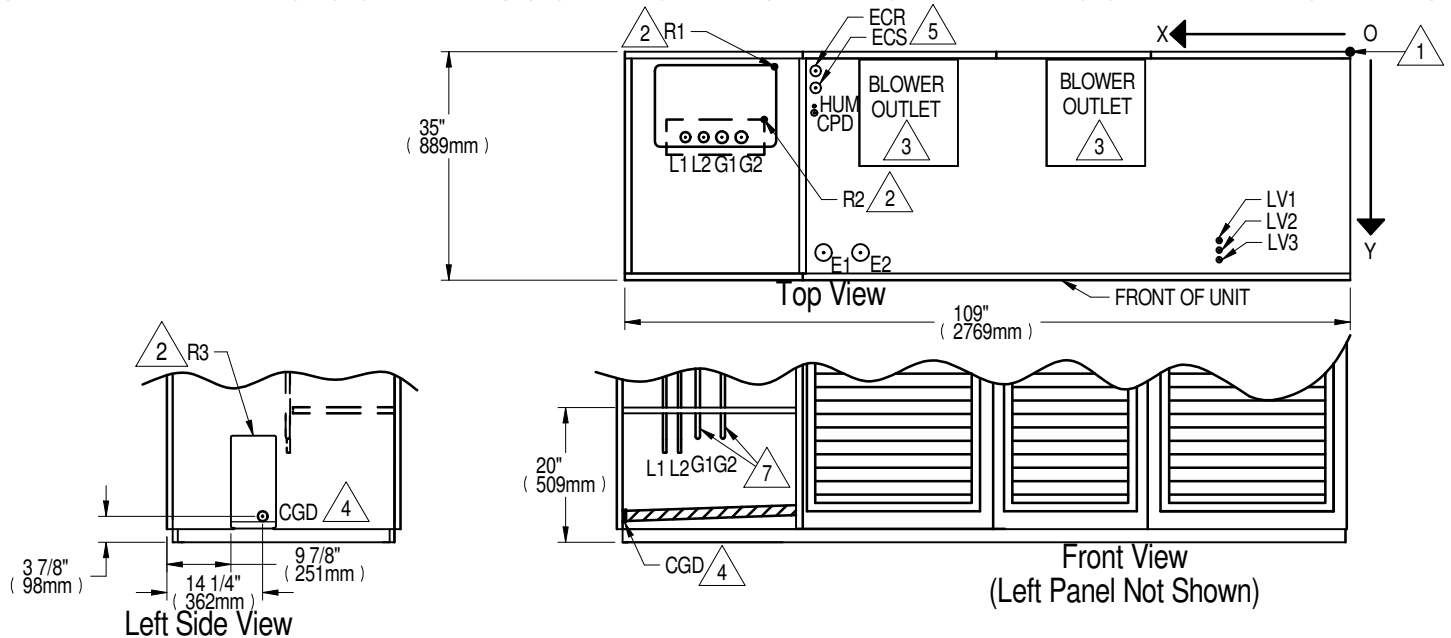

Notes:

1. Drawing not to scale. All dimensions from rear corner of unit including panels, and have a tolerance of $\pm 1/2"$ (13mm).
2. Field routed alternatives for refrigerant gas & liquid line connection points.
3. Forward Curved Blowers shown. See submittal page DPN001191 for blower outlet and deck dimensional data.
4. Field pitch Condensate Drain line a minimum of $1/8"$ (3.2 mm) per foot (305 mm). All units contain a factory installed condensate trap. Do not trap external to the unit. Select appropriate drain system materials. The drain line must comply with all local codes.
5. Supplied on Dual Cooling Systems only.
6. When piping out the top of the unit, field must install traps in the discharge lines in the bottom of the unit before running lines to the top.

POINT	DESCRIPTION	X in. (mm)	Y in. (mm)	CONNECTION SIZE / OPENING
R1	REFRIGERANT ACCESS (TOP) ²	83-3/4 (2127)	1-7/8 (48)	22-1/2"(572mm) X 15-3/16" (386mm)
R2	REFRIGERANT ACCESS (BOTTOM) ²	86 (2184)	13-7/8 (352)	16-7/16" (418mm) X 4" (102mm)
R3	REFRIGERANT ACCESS (SIDE) ²	N/A	N/A	6" (152mm) X 17-3/16" (437mm)
L1	LIQUID LINE SYSTEM 1	97 (2464)	16-3/4 (425)	5/8" O.D. Cu
L2	LIQUID LINE SYSTEM 2	93-5/16 (2370)		
G1	HOT GAS DISCHARGE 1 ⁶	90-5/8 (2302)	16-5/8 (422)	1-1/8" O.D. Cu
G2	HOT GAS DISCHARGE 2 ⁶	88 (2235)		
CGD	CONDENSATE GRAVITY DRAIN ⁴	N/A	N/A	3/4" NPT FEMALE
CPD	CONDENSATE PUMP DISCHARGE (OPT)	79-5/16 (2015)	11-7/8 (302)	1/2" O.D. Cu
HUM	HUMIDIFIER SUPPLY LINE		9-7/8 (251)	1/4" O.D. Cu
ECS	LIEBERT® ECON-O-COIL SUPPLY ⁵	78-5/8 (1997)	7-7/8 (200)	2-1/8" O.D. Cu
ECR	LIEBERT® ECON-O-COIL RETURN ⁵		4-5/8 (117)	
E1	ELECTRICAL CONN. (HIGH VOLT)	75-3/8 (1915)	30 (762)	2-1/2"
E2		69-7/8 (1775)		
LV1	ELECTRICAL CONN. (LOW VOLT)		29-1/16 (738)	7/8"
LV2		19-1/2 (495)	30-1/2 (775)	
LV3			31-15/16 (811)	

PRIMARY CONNECTION LOCATIONS UPFLOW AIR COOLED 53-77kW 15-22 TONS SCROLL OR DIGITAL SCROLL COMPRESSORS

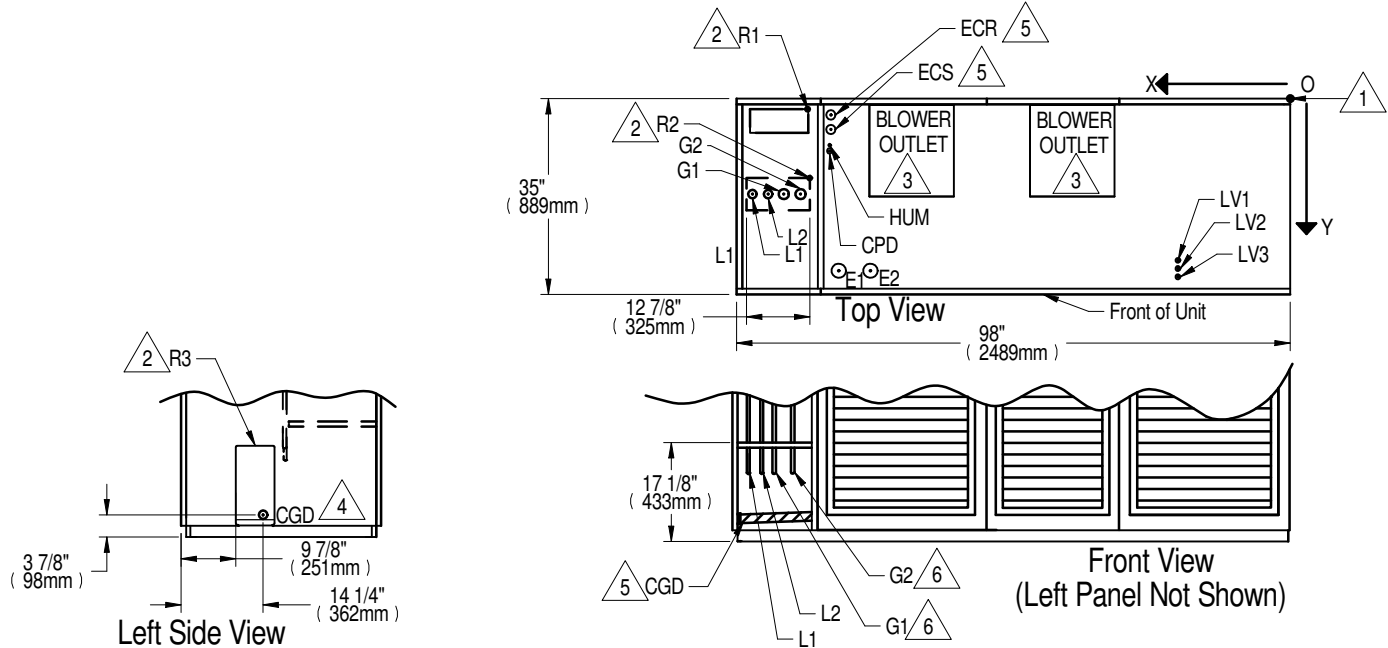

Notes:

1. Drawing not to scale. All dimensions from rear corner of unit including panels, and have a tolerance of $\pm 1/2"$ (13mm).
2. Field routed alternatives for refrigerant gas and liquid line connection points.
3. Forward Curved Blowers shown. See submittal page DPN001191 for blower outlet and deck dimensional data.
4. Field pitch Condensate Drain line a minimum of $1/8"$ (3.2 mm) per foot (305 mm). All units contain a factory installed condensate trap. Do not trap external to the unit. Select appropriate drain system materials. The drain line must comply with all local codes.
5. Supplied on Dual Cooling Systems only.
6. When piping out the top of the unit, field must install traps in the discharge lines in the bottom of the unit before running the lines to the top.
7. Digital Scroll Compressor not available on DS077 models.

POINT	DESCRIPTION	X in. (mm)	Y in. (mm)	CONNECTION SIZE / OPENING	
R1	REFRIGERANT ACCESS (TOP)	83-5/8 (2124)	2 (51)	12" (305mm) X 4" (102mm)	
R2	REFRIGERANT ACCESS (BOTTOM)	82-3/4 (2102)	14-3/4 (375)	12-3/16" (310mm) X 4" (102mm)	
R3	REFRIGERANT ACCESS (SIDE)	N/A	N/A	6" (152mm) X 17-3/16" (437mm)	
				53kW (15T ONS) / 70 & 77kW (20 & 22T ONS)	
L1	LIQUID LINE SYSTEM 1	94-11/16 (2405)	16-3/4 (425)	1/2" O.D. Cu	5/8" O.D. Cu
L2	LIQUID LINE SYSTEM 2	91-7/8 (2334)			
G1	HOT GAS DISCHARGE 1	88-3/4 (2254)	16-3/8 (416)	7/8" O.D. Cu	1-1/8" O.D. Cu
G2	HOT GAS DISCHARGE 2	85-9/16" (2173)			
CGD	CONDENSATE GRAVITY DRAIN	N/A	N/A	3/4" NPT FEMALE	
CPD	CONDENSATE PUMP DISCHARGE (OPT)	79-5/16 (2015)	11-7/8 (302)	1/2" O.D. Cu	
HUM	HUMIDIFIER SUPPLY LINE		9-7/8 (251)	1/4" O.D. Cu	
ECS	LIEBERT® ECON-O-COIL SUPPLY	78-5/8 (1997)	7-7/8 (200)	2-1/8" O.D. Cu	
ECR	LIEBERT® ECON-O-COIL RETURN		4-5/8 (117)		
E1	ELECTRICAL CONN. (HIGH VOLT)	75-3/8 (1915)	30 (762)	2-1/2"	
E2		69-7/8 (1775)			
LV1	ELECTRICAL CONN. (LOW VOLT)	19-1/2 (495)	29-1/16 (738)	7/8"	
LV2			30-1/2 (775)		
LV3			31-15/16 (811)		



VERTIV™

LIEBERT® DS

PRIMARY CONNECTION LOCATIONS

UPFLOW AIR COOLED 105kW (30 TONS) ALL COMPRESSOR MODELS

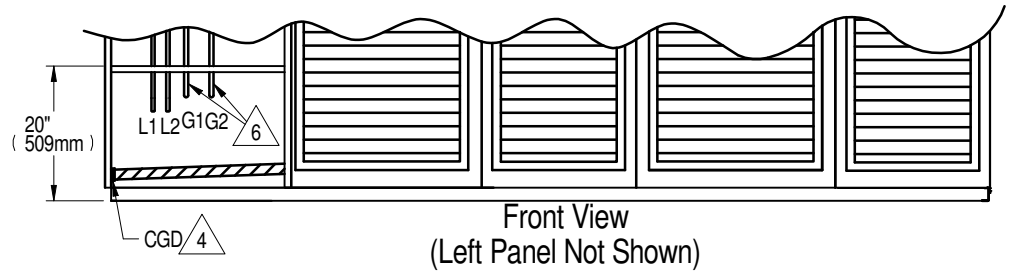
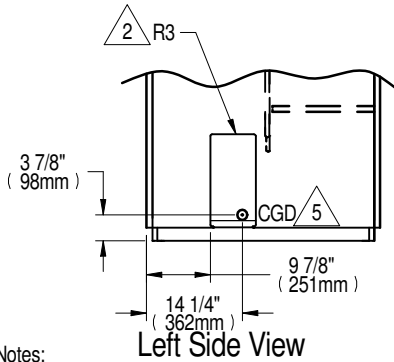
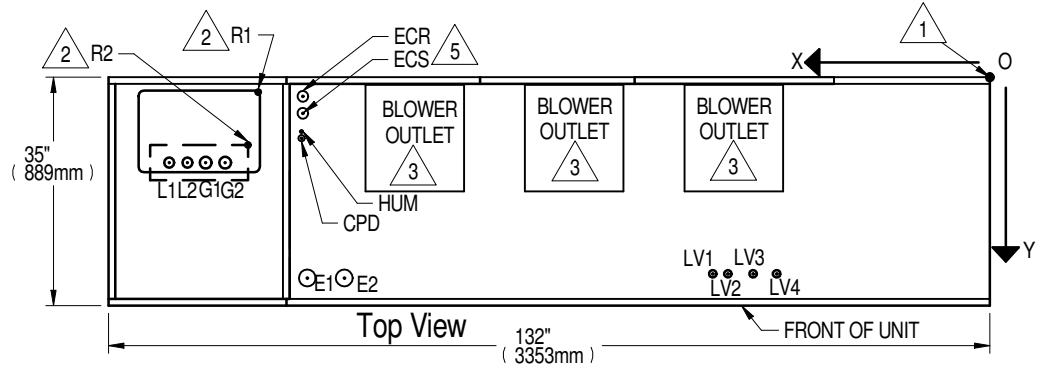

Notes:

- 1. Drawing not to scale. All dimensions from rear corner of unit including panel, and have a tolerance of ± 1/2" (13mm).
- 2. Field routed alternatives for refrigerant gas and liquid line connection points.
- 3. Forward Curved Blowers shown. See submittal page DPN001192 for blower outlet and deck dimensional data.
- 4. Field pitch Condensate Drain line a minimum of 1/8" (3.2 mm) per foot (305 mm). All units contain a factory installed condensate trap. Do not trap external to the unit. Select appropriate drain system materials. The drain line must comply with all local codes.
- 5. Supplied on Dual Cooling Systems only.
- 6. When piping out the top of the unit, field must install traps in the discharge lines in the bottom of the unit before running lines to the top.
- 7. Digital Scroll compressors not available on 105kW models.

POINT	DESCRIPTION	X in. (mm)	Y in. (mm)	CONNECTION SIZE / OPENING
R1	REFRIGERANT ACCESS (TOP) 2	106-7/8 (2715)	1-7/8 (48)	22-1/2"(572mm) X 15-3/16" (386mm)
R2	REFRIGERANT ACCESS (BOTTOM) 2	109-1/8 (2772)	13-7/8 (352)	16-7/16" (418mm) X 4" (102mm)
R3	REFRIGERANT ACCESS (SIDE) 2	N/A	N/A	6" (152mm) X 17-3/16" (437mm)
L1	LIQUID LINE SYSTEM 1	121-3/4 (3092)	16-3/4 (425)	5/8" O.D. Cu
L2	LIQUID LINE SYSTEM 2	118-1/8 (3000)		
G1	HOT GAS DISCHARGE 1 6	118-1/4 (3004)	14-1/4 (362)	1-1/8" O.D. Cu
G2	HOT GAS DISCHARGE 2 6	115-5/8 (2937)		
CGD	CONDENSATE GRAVITY DRAIN 4	N/A	N/A	3/4" NPT FEMALE
CPD	CONDENSATE PUMP DISCHARGE (OPT)	102-3/8 (2600)	13-5/8 (346)	1/2" O.D. Cu
HUM	HUMIDIFIER SUPPLY LINE		13-1/8 (333)	1/4" O.D. Cu
ECS	LIEBERT® ECON-O-COIL 5	101-1/8 (2569)	10-1/4 (260)	2-5/8" O.D. Cu
ECR	LIEBERT® ECON-O-COIL 5		5-1/4 (133)	
E1	ELECTRICAL CONN. (HIGH VOLT)	98-1/2 (2502)	30 (762)	2-1/2"
E2		93 (2362)		
LV1	ELECTRICAL CONN. (LOW VOLT)	41-1/8 (1045)	30-3/8 (772)	7/8"
LV2		38-7/8 (987)		
LV3		35-1/8 (892)		
LV4		31-5/8 (803)		

PRIMARY CONNECTION LOCATIONS
UPFLOW WATER/GLYCOL/GLYCOOL 35-42kW (10-12 TONS) SCROLL & DIGITAL SCROLL COMPRESSOR MODELS W/ FORWARD CURVED BLOWER

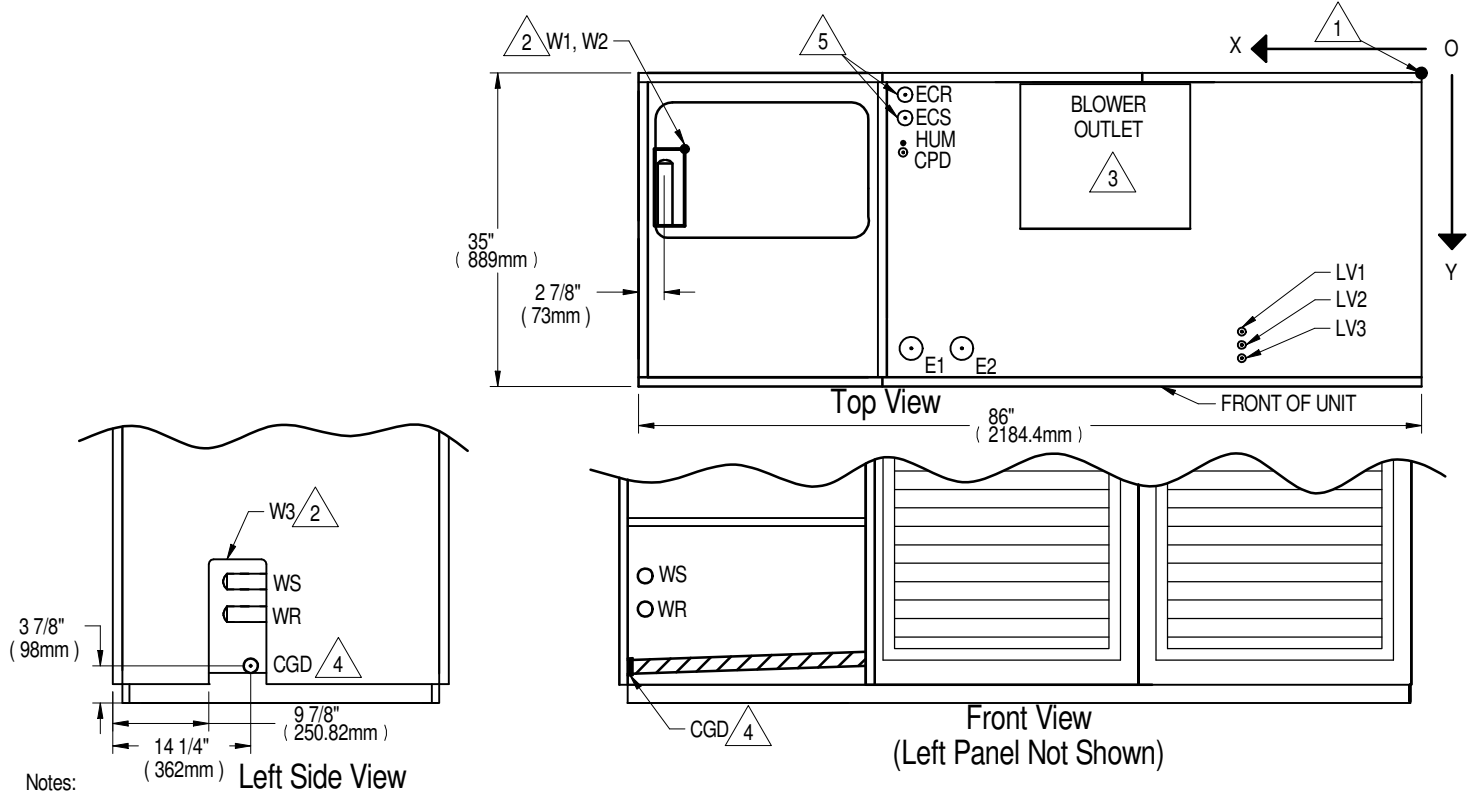

Notes:

1. Drawing not to scale. All dimensions from rear corner of unit including panels and have a tolerance of $\pm 1/2"$ (13mm).
2. Field routed alternatives for water/glycol connections.
3. Forward Curved Blower shown. See submittal page DPN001120 for blower outlet and deck dimensional data.
4. Field pitch Condensate Drain line a minimum of 1/8" (3.2 mm) per foot (305 mm). All units contain a factory installed condensate trap. Do not trap external to the unit. Select appropriate drain system materials. The drain line must comply with all local codes.
5. Supplied on Dual Cooling Systems only (four-pipe system).



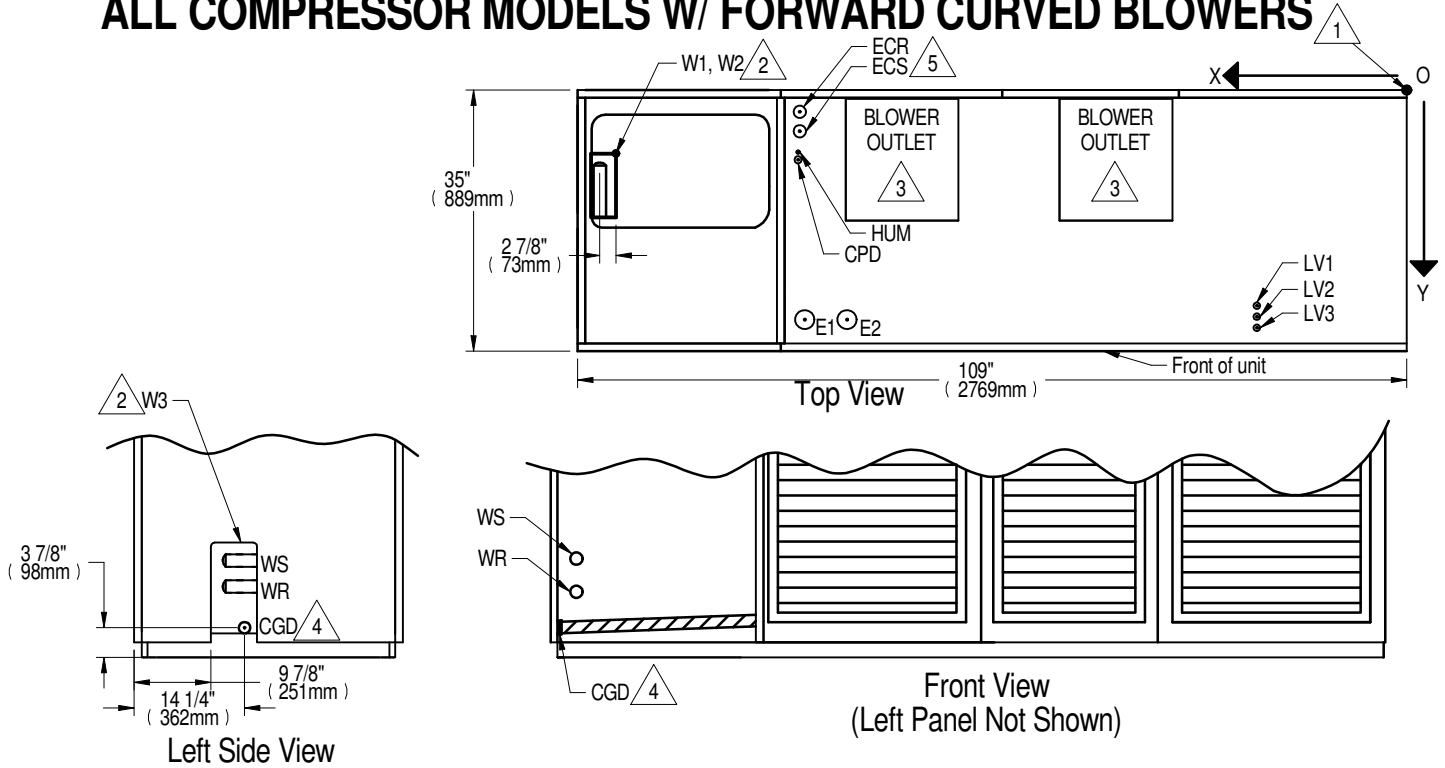

POINT	DESCRIPTION	X in. (mm)	Y in. (mm)	CONNECTION SIZE / OPENING	
				35kW (10 TON)	42kW (12 TON)
W1	WATER/GLYCOL/GLYCOOL ACCESS (BOTTOM) ²	79-15/16 (2030)	9 (229)	3-1/2" (89mm) X 8" (203mm)	
W2	WATER/GLYCOL/GLYCOOL ACCESS (TOP) ²			6" (152mm) x 17-3/16" (437mm)	
W3	WATER/GLYCOL/GLYCOOL ACCESS (SIDE) ²	N/A	N/A	1-5/8" O.D. Cu 2-1/8" O.D. Cu	
WS	WATER/GLYCOL/GLYCOOL SUPPLY	56 (1422)	7-5/16 (186)	1-5/8" O.D. Cu 2-1/8" O.D. Cu	
WR	WATER/GLYCOL/GLYCOOL RETURN			1-5/8" O.D. Cu 2-1/8" O.D. Cu	
ECS	LIEBERT® ECON-O-COIL SUPPLY ⁵	56-1/4 (1429)	11-1/8 (283)	3/4" NPT FEMALE	
ECR	LIEBERT® ECON-O-COIL RETURN ⁵			3/4" NPT FEMALE	
CGD	CONDENSATE GRAVITY DRAIN ⁴	N/A	N/A	3/4" NPT FEMALE	
CPD	CONDENSATE PUMP DISCHARGE (OPT)	56-1/4 (1429)	11-1/8 (283)	1/2" O.D. Cu	
HUM	HUMIDIFIER SUPPLY LINE			1/4" O.D. Cu	
E1	ELECTRICAL CONN. (HIGH VOLT)	52-3/8 (1330)	30 (762)	2-1/2"	
E2		46-7/8 (1191)		2-1/2"	
LV1	ELECTRICAL CONN. (LOW VOLT)	19-1/2 (495)	29-1/16 (738)	7/8"	
LV2			30-1/2 (775)	7/8"	
LV3			31-15/16 (811)	7/8"	

PRIMARY CONNECTION LOCATIONS UPFLOW WATER/GLYCOL/GLYCOOL 53-77kW (15-22 TONS) ALL COMPRESSOR MODELS W/ FORWARD CURVED BLOWERS



Notes:

1. Drawing not to scale. All dimensions are from rear corner if unit including panels, and have a tolerance of $\pm 1/2"$ (13mm).
2. Field routed alternatives for water/glycol connections.
3. Forward Curved Blowers shown. See submittal page DPN001191 for blower outlet and deck dimensional data.
4. Field pitch Condensate Drain line a minimum of 1/8" (3.2 mm) per foot (305 mm). All units contain a factory installed condensate trap. Do not trap external to the unit. Select appropriate drain system materials. The drain line must comply with all local codes.
5. Supplied on Dual Cooling Systems only (four-pipe system).
6. Scroll and Digital Scroll compressors not available on 77kW models.
7. Semi-Hermetic Compressor only available on 77kW models.

POINT	DESCRIPTION	X in. (mm)	Y in. (mm)	CONNECTION SIZE / OPENING
W1	WATER/GLYCOL/GLYCOOL ACCESS (BOTTOM) 	102-15/16 (2615)	9 (229)	3-1/2" (89mm) X 8" (203mm)
W2	WATER/GLYCOL/GLYCOOL ACCESS (TOP)			
W3	WATER/GLYCOL/GLYCOOL ACCESS (SIDE) 			
WS	WATER/GLYCOL/GLYCOOL SUPPLY	N/A	N/A	2-1/8" O.D. Cu
WR	WATER/GLYCOL/GLYCOOL RETURN			
CGD	CONDENSATE GRAVITY DRAIN 			3/4" NPT FEMALE
CPD	CONDENSATE PUMP DISCHARGE (OPT)	79-5/16 (2015)	11-7/8 (302)	1/2" O.D. Cu
HUM	HUMIDIFIER SUPPLY LINE		9-7/8 (251)	1/4" O.D. Cu
ECS	LIEBERT® ECON-O-COIL SUPPLY 	78-5/8 (1997)	7-7/8 (200)	2-1/8" O.D. Cu
ECR	LIEBERT® ECON-O-COIL RETURN 		4-5/8 (117)	
E1	ELECTRICAL CONN. (HIGH VOLT)	75-3/8 (1915)	30 (762)	2-1/2"
E2	ELECTRICAL CONN. (HIGH VOLT)	69-7/8 (1775)		
LV1	ELECTRICAL CONN. (LOW VOLT)	19-1/2 (495)	29-1/16 (738)	7/8"
LV2	ELECTRICAL CONN. (LOW VOLT)		30-1/2 (775)	
LV3	ELECTRICAL CONN. (LOW VOLT)		31-15/16 (811)	

PRIMARY CONNECTION LOCATIONS UPFLOW WATER/GLYCOL/GLYCOOL 105kW (30 TONS) ALL COMPRESSOR MODELS

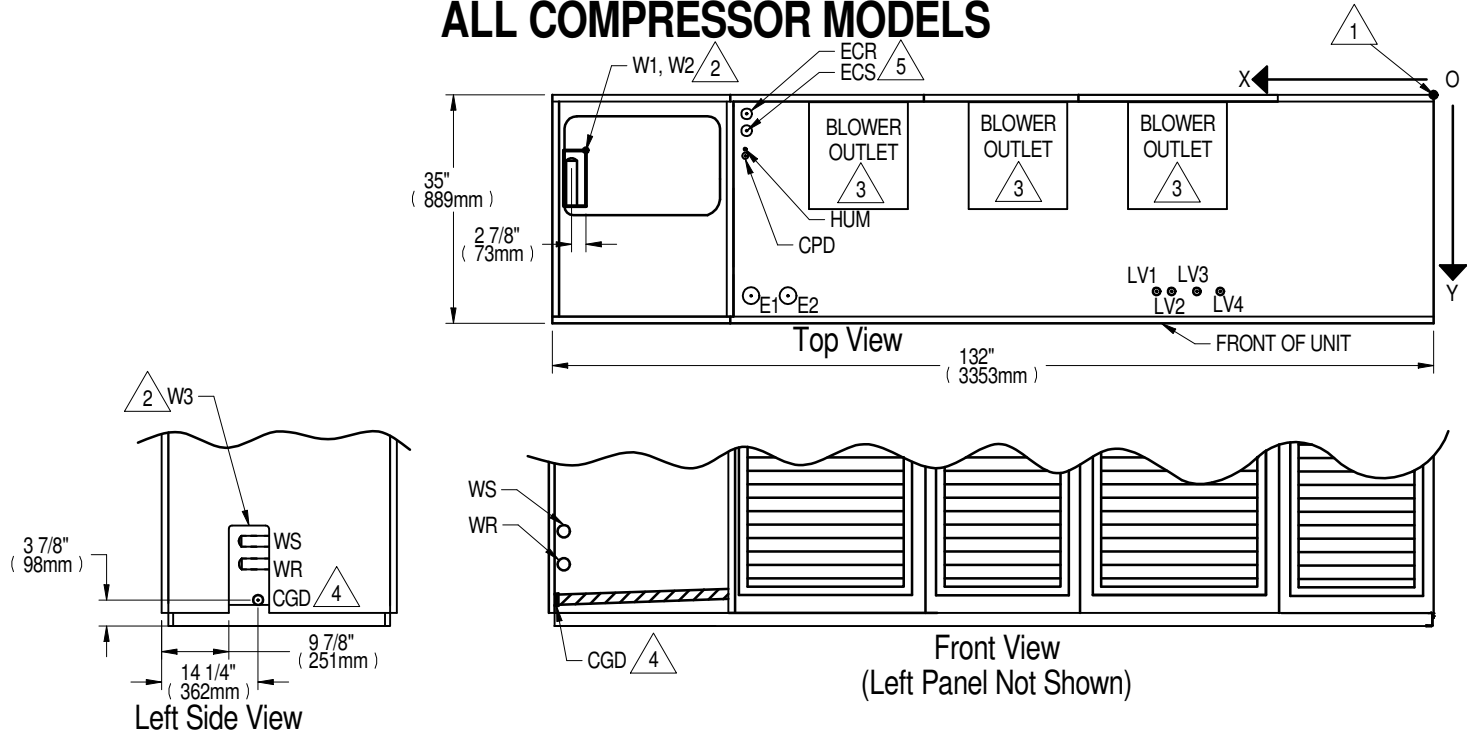

Notes:

1. Drawing not to scale. All dimensions from rear corner of unit including panels, and have a tolerance of $\pm 1/2"$ (13mm).
2. Field routed alternatives for water/glycol connections.
3. Forward Curved Blowers shown. See submittal page DPN001192 for blower outlet and deck dimensional data.
4. Field pitch Condensate Drain line a minimum of $1/8"$ (3.2 mm) per foot (305 mm). All units contain a factory installed condensate trap. Do not trap external to the unit. Select appropriate drain system materials. The drain line must comply with all local codes.
5. Supplied on Dual Cooling Systems only (four-pipe systems).
6. Scroll and Digital Scroll compressors are not available on 105kW models.

POINT	DESCRIPTION	X in. (mm)	Y in. (mm)	CONNECTION SIZE / OPENING
W1	WATER/GLYCOL/GLYCOOL ACCESS (BOTTOM)	126-1/8 (3204)	9 (229)	3-1/2" (89mm) X 8" (203mm)
W2	WATER/GLYCOL/GLYCOOL ACCESS (TOP)			
W3	WATER/GLYCOL/GLYCOOL ACCESS (SIDE)	N/A	N/A	6" (152mm) x 17-3/16" (437mm)
WS	WATER/GLYCOL/GLYCOOL SUPPLY			2-1/8" O.D. Cu
WR	WATER/GLYCOL/GLYCOOL RETURN			3/4" NPT FEMALE
CGD	CONDENSATE GRAVITY DRAIN			
CPD	CONDENSATE PUMP DISCHARGE (OPT)	102-3/8 (2600)	13-5/8 (346)	1/2" O.D. Cu
HUM	HUMIDIFIER SUPPLY LINE		13-1/8 (333)	1/4" O.D. Cu
ECS	LIEBERT® ECON-O-COIL SUPPLY	101-1/8 (2569)	10-1/4 (260)	2-5/8" O.D. Cu
ECR	LIEBERT® ECON-O-COIL RETURN		5-1/4 (133)	
E1	ELECTRICAL CONN. (HIGH VOLT)	98-1/2 (2502)	30 (762)	2-1/2"
E2	ELECTRICAL CONN. (HIGH VOLT)	93 (2362)		
LV1	ELECTRICAL CONN. (LOW VOLT)	41-1/8 (1045)	30-3/8 (772)	7/8"
LV2	ELECTRICAL CONN. (LOW VOLT)	38-7/8 (987)		
LV3	ELECTRICAL CONN. (LOW VOLT)	35-1/8 (892)		
LV4	ELECTRICAL CONN. (LOW VOLT)	31-5/8 (803)		



ELECTRICAL FIELD CONNECTION DESCRIPTION UPFLOW AND DOWNFLOW MODELS

STANDARD ELECTRICAL CONNECTIONS

- 1) **Primary high voltage entrance** - 2.50" (64mm); 1.75" (44mm); 1.375" (35mm) diameter concentric knockouts located in bottom of box
- 2) **Secondary high voltage entrance** - 2.50" (64mm); 1.75" (44mm); 1.375" (35mm) diameter concentric knockouts located in top of box
- 3) **Primary low voltage entrance** - Quantity (3) 1.375" (35mm) diameter knockouts located in bottom of unit
- 4) **Secondary low voltage entrance** - Quantity (3) 1.375" (35mm) diameter knockouts located in top of box
- 5) **Three phase electrical service** - Terminals are on main fuse block (disregard if unit has optional disconnect switch). Three phase service not by Vertiv.
- 6) **Earth ground** - Terminal for field supplied earth grounding wire. Earth grounding required for Vertiv units.
- 7) **Remote unit shutdown** - Replace existing jumper between terminals 37 & 38 with field supplied normally closed switch having a minimum 75VA, 24VAC rating. Use field supplied Class 1 wiring.
- 8) **Customer alarm inputs** - Terminals for field supplied, normally open contacts, having a minimum 75VA, 24VAC rating, between terminals 24 & 50, 51, 55, 56. Use field supplied Class 1 wiring. Terminal availability varies by unit options.
- 9) **Common alarm** - On any alarm, normally open dry contact is closed across terminals 75 & 76 for remote indication. 1 AMP, 24VAC max load. Use Class 1 field supplied wiring.
- 10) **Heat rejection interlock** - On any call for compressor operation, normally open dry contact is closed across terminals 70 & 71 (circuit 1), 230 (circuit 2) to heat rejection equipment. 1 AMP, 24VAC max load. Use Class 1 field supplied wiring. When Liebert® DS unit is paired with a Liebert® MC series condenser, remove jumper between terminal 71 and terminal 230. Three wires must connect terminals 70, 71 and 230 of the indoor unit to terminals 70, 71 and 230 of the Liebert® MC series condenser.
- 11) **Unit factory installed disconnect switch, Fuse Block and Main Fuses** – “Locking Type” consists of a non-automatic molded case switch operational from the outside of the unit. Access to the high voltage electric panel compartment can be obtained only with the switch in the “off” position. Units with fused disconnects are provided with a def eater button that allows access to the electrical panel when power is on. The molded case switch disconnect models contain separate main fuses.

CANBUS ELECTRICAL CONNECTIONS

- 12) **CANbus Connector**– Terminal block with terminals 49-1 (CAN-H) and 49-3 (CAN-L) + SH (shield connection). The terminals are used to connect the CANbus communication cable (provided by others) from the indoor unit to the Liebert® MC –Optional Liebert® EconoPhase Unit.
- 13) **CANbus Cable** – CANbus cable provided by others to connect to the outdoor condenser, and optional PRE unit (DA units only). No special considerations are required when the total external cable connection between the indoor unit and outdoor unit(s) is less than 450FT (137M). For total external cable connections greater than 450FT (137M) but less than 800FT (243M) a CANbus isolator is required. Contact Factory.
Cable must have the following specifications:
 - Braided shield or foil shield with drain wire
 - Shield must be wired to ground at indoor unit
 - 22-18AWG stranded tinned copper
 - Twisted pair (minimum 4 twists per foot)
 - Low Capacitance (15pF/FT or less)
 - Must be rated to meet local codes and conditions
 - EXAMPLES BELDEN 89207 (PLENUM RATED), OR ALPHA WIRE 6454 CATEGORY 5, 5E, OR HIGHER
- 14) Do not run in same conduit, raceway, or chase as high voltage wiring.
- 15) For CANbus network lengths greater than 450FT (137M) call Factory.

ELECTRICAL FIELD CONNECTION DESCRIPTION

UPFLOW AND DOWNFLOW MODELS

OPTIONAL ELECTRICAL CONNECTIONS

- 16) **Smoke sensor alarm - Factory** wired dry contacts from smoke sensor are 91-common, 92-NO, and 93-NC. Supervised contacts, 80 & 81, open on sensor trouble indication. This smoke sensor is not intended to function as, or replace, any room smoke detection system that may be required by local or national codes. 1 AMP, 24VAC max load. Use Class 1 field supplied wiring.
- 17) **Reheat and humidifier lockout** - Remote 24VAC required at terminals 82 & 83 for lockout of reheat and humidifier.
- 18) **Condensate alarm** (with condensate pump option) - On pump high water indication, normally open dry contact is closed across terminals 88 & 89 for remote indication. 1 AMP, 24VAC max load. Use Class 1 field supplied wiring.
- 19) **Remote humidifier** - On any call for humidification, normally open dry contact is closed across terminals 11 & 12 to signal field supplied remote humidifier. 1 AMP, 24VAC max load. Use Class 1 field supplied wiring.
- 20) **Auxiliary cool contact** - On any call for Liebert® Econ-o-Coil operation, normally open dry contact is closed across terminals 72 & 73 on dual cool units only. 1 AMP, 24VAC max load. Use Class 1 field supplied wiring.
- 21) **Analog Inputs**- Terminals 41, 42, 43, 44 are user configurable for 0-10V, 0-5V, or 4-20MA.

OPTIONAL LOW VOLTAGE TERMINAL PACKAGE CONNECTIONS

- 22) **Remote unit shutdown** - Two additional contact pairs available for unit shutdown (labeled as 37B & 38B, 37C & 38C). Replace jumpers with field supplied normally closed switch having a minimum 75VA, 24VAC rating. Use field supplied Class 1 wiring.
- 23) **Common alarm** - On any alarm, two additional normally open dry contacts are closed across terminals 94 & 95 and 96 & 97 for remote indication. 1 AMP, 24VAC max load. Use Class 1 field supplied wiring.
- 24) **Main fan auxiliary switch** - On closure of main fan contactor, normally open dry contact is closed across terminals 84 & 85 for remote indication. 1 AMP, 24VAC max load. Use Class 1 field supplied wiring.
- 25) **Liqui-Tect shutdown and dry contact** - On Liebert® Liqui-Tect™ activation, normally open dry contact is closed across terminals 58 & 59 for remote indication (Liebert® Liqui-Tect™ sensor ordered separately). 1 AMP, 24VAC max load. Use Class 1 field supplied wiring.

OPTIONAL COMMUNICATION CONNECTIONS

- 26) **Unit-To-Unit** – Plug 64 is reserved for U2U communication
- 27) **Site and BMS**- Plug 74 and terminal block 3 are reserved for Site and BMS connections. Plug 74 is an eight pin RJ45 for a Cat 5 cable. Terminal block 3 is a two position screw terminal block for use with twisted pair wires.

NOTE: Refer to specification sheet for total unit full load amps, wire size amps, and max overcurrent protective device size.

ELECTRICAL FIELD CONNECTION DESCRIPTION UPFLOW AND DOWNFLOW MODELS

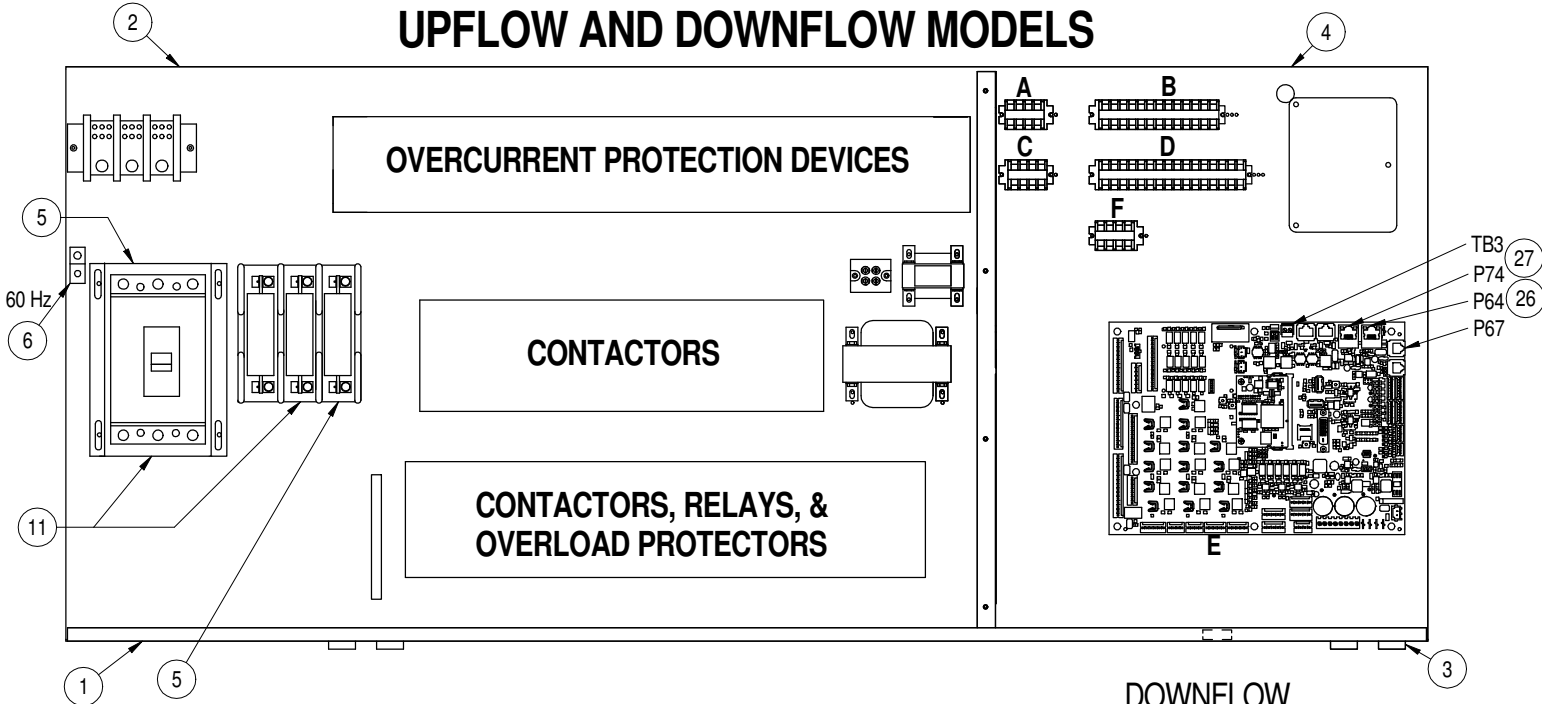

Note: Typical orientation of components shown. Component location varies by option and unit size.

DOWNFLOW LOW VOLT SECTION

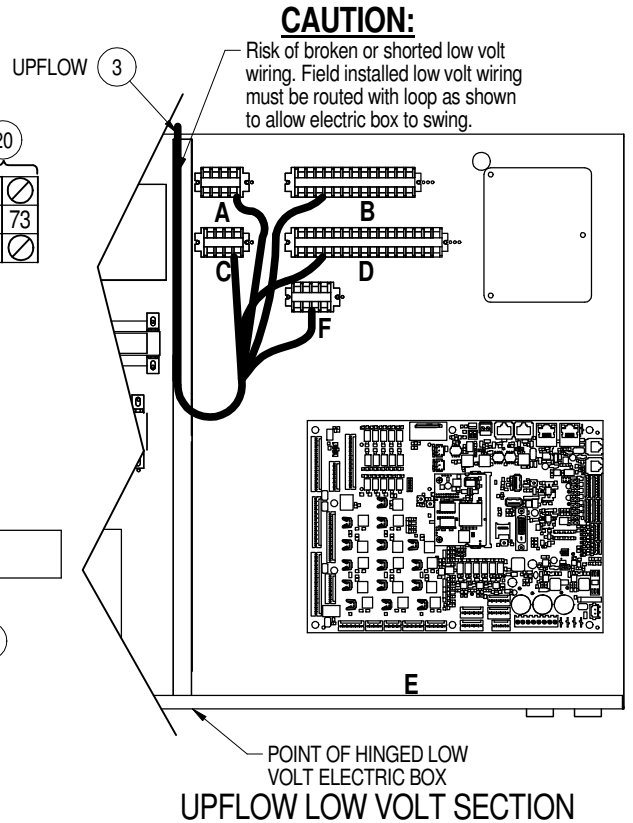
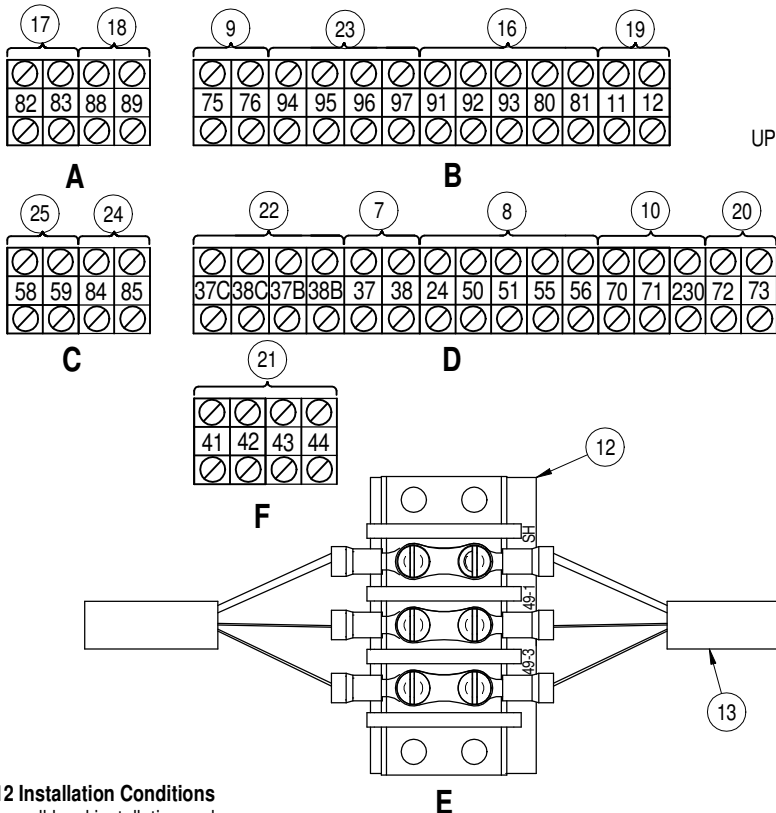

Item 12 Installation Conditions

1. Follow all local installation codes.
2. Do not run CAN cables in same conduit, raceway, or chase as high voltage wires (120-600V).
3. Separate high volt wires from CAN wires by 12 inches.

CANbus & INTERLOCK CONNECTIONS BETWEEN LIEBERT® DS & LIEBERT® MC (PREMIUM)

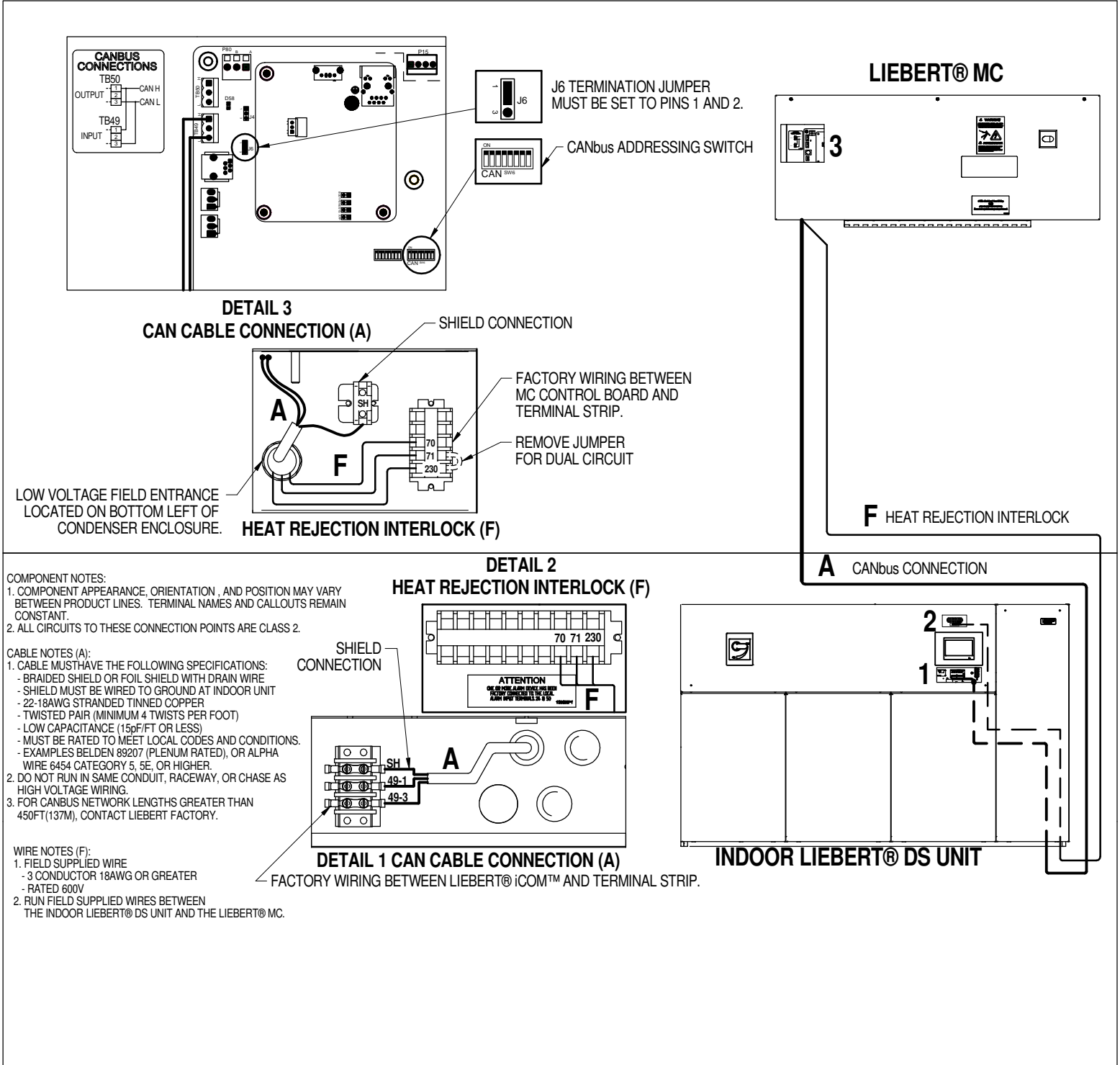

DISASSEMBLY DIMENSIONAL DATA DOWNFLOW 35-42kW (10-12 TONS) MODELS W/ SCROLL & DIGITAL SCROLL COMPRESSORS

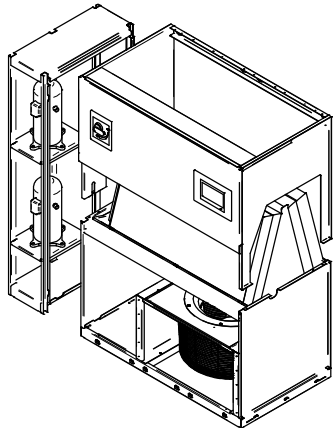

Liebert® DS Unit w/ Scroll/Digital Scroll Compressor Section

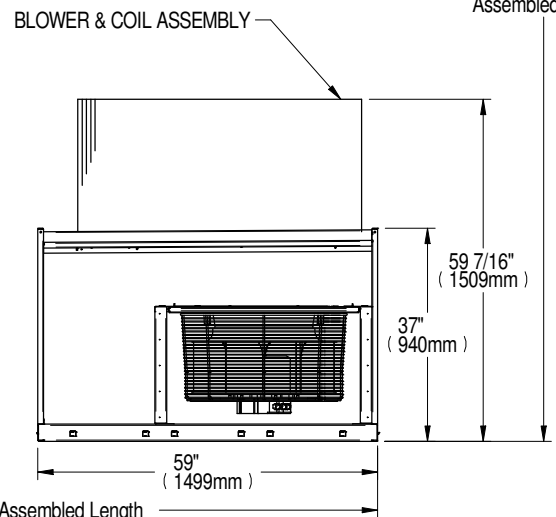
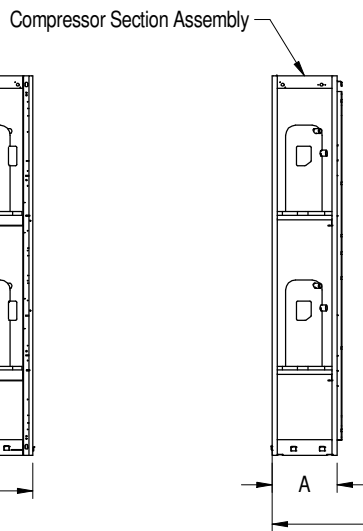
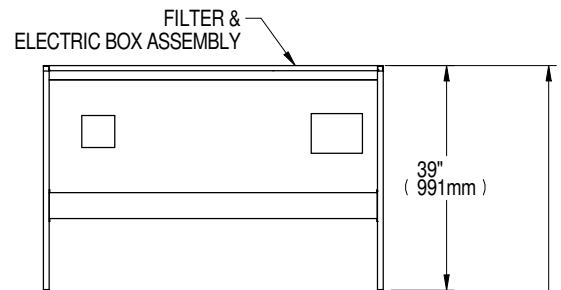

76"
(1930mm)
Assembled Height

B Assembled Length

Cooling Type	A in. (mm)	B in. (mm)
Air Cooled	13 (330)	72 (1829)
Air Cooled w/Dual Cool		
Water/Glycol	26 (660)	85 (2159)
GLYCOOL/Dual Cool		

Assembly	APPROXIMATE DRY WEIGHT lb (kg) (Includes Panels)			
	Air Cooled	A/C w/ Dual Cool	Water/Glycol	GLYCOOL/Dual Cool
Compressor Assembly	490 (223)	490 (223)	800 (364)	800 (364)
Filter & Electric Box Assembly	210 (96)	210 (96)	210 (96)	210 (96)
Blower & Coil Assembly	770 (350)	920 (418)	770 (350)	920 (418)

Notes:

1. Drawing Views are simplified with panels removed to show overall dimensions. See disassembly and handling instructions in installation manual.

DISASSEMBLY DIMENSIONAL DATA DOWNFLOW 53-77kW (15-22 TONS) MODELS

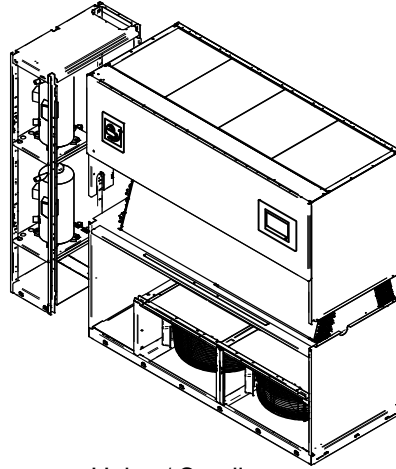

Unit w/ Scroll
Compressor Section

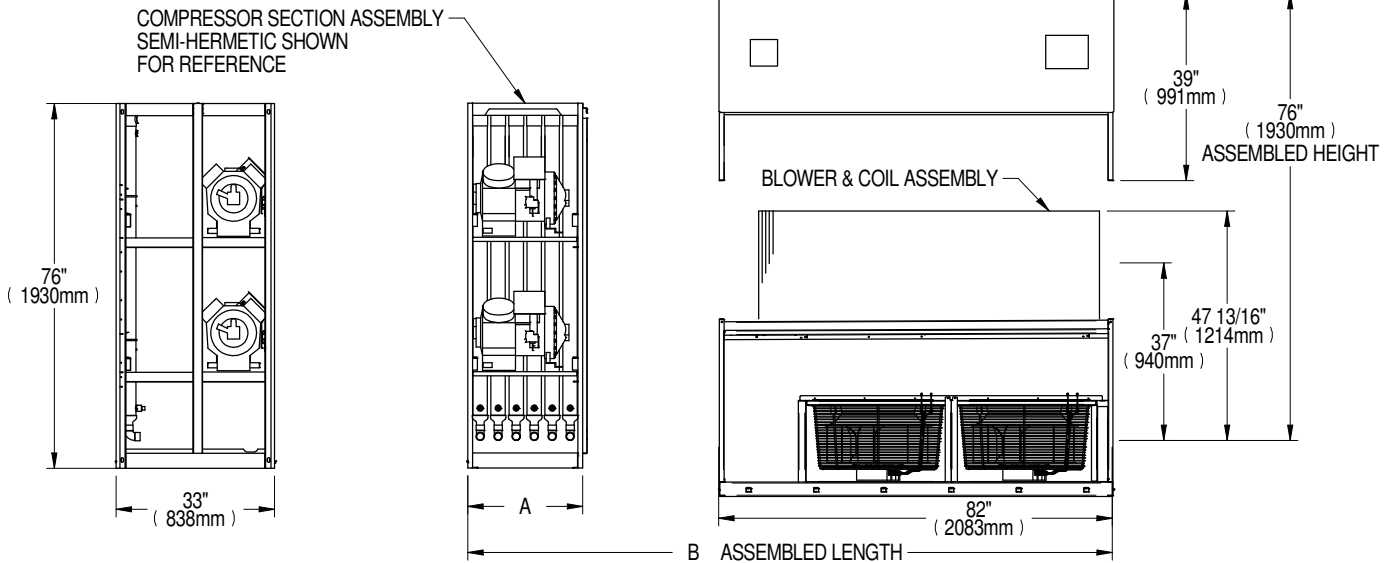

Compressor Type	Cooling Type	A in. (mm)	B in. (mm)
Scroll or Digital Scroll 3	Air Cooled	15 (381)	97 (2464)
	Air Cooled w/ Dual Cool		
	Water/Glycol	26 (660)	108 (2743)
	GLYCOOL/Dual Cool		
Semi-Hermetic 2	Air Cooled	26 (660)	108 (2743)
	Air Cooled w/ Dual Cool		
	Water/Glycol	26 (660)	108 (2743)
	GLYCOOL/Dual Cool		

Notes:

- Drawing Views are simplified with panels removed to show overall dimensions. See disassembly and handling instructions in installation manual.
- Semi-Hermetic Compressor options only available on 77kW models.
- Scroll compressors option only available on air cooled models and water/glycol units with a capacity up to 70kW.

Assembly	APPROXIMATE DRY WEIGHT lb (kg) (Includes Panels)							
	Semi-Hermetic Compressor		3 Scroll or Digital Scroll Compressor		2 Semi-Hermetic Compressor		3 Scroll or Digital Scroll Compressor	
	Air Cooled	A/C w/ Dual Cool	Air Cooled	A/C w/ Dual Cool	Water/Glycol	GLYCOOL/Dual Cool	Water/Glycol	GLYCOOL/Dual Cool
Compressor Assembly	970 (441)	970 (441)	540 (246)	540 (246)	1270 (578)	1270 (578)	840 (382)	840 (382)
Filter & Electric Box Assembly	250 (114)	250 (114)	250 (114)	250 (114)	250 (114)	250 (114)	250 (114)	250 (114)
Blower & Coil Assembly	1230 (560)	1410 (641)	1230 (560)	1410 (641)	1230 (560)	1410 (641)	1230 (560)	1410 (641)

DISASSEMBLY DIMENSIONAL DATA DOWNFLOW 105kW (30 TONS) MODELS

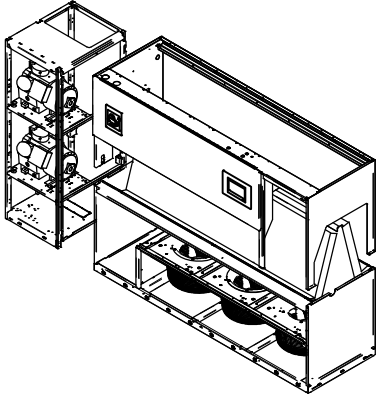

Liebert® DS Unit w/ Semi-Hermetic Compressor Section

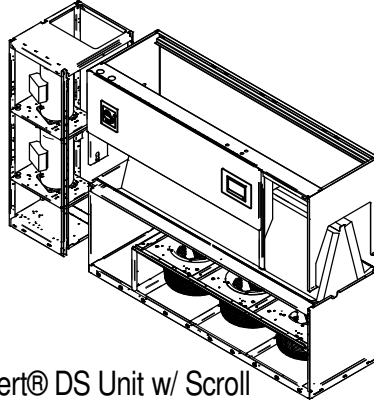

Liebert® DS Unit w/ Scroll Compressor Section

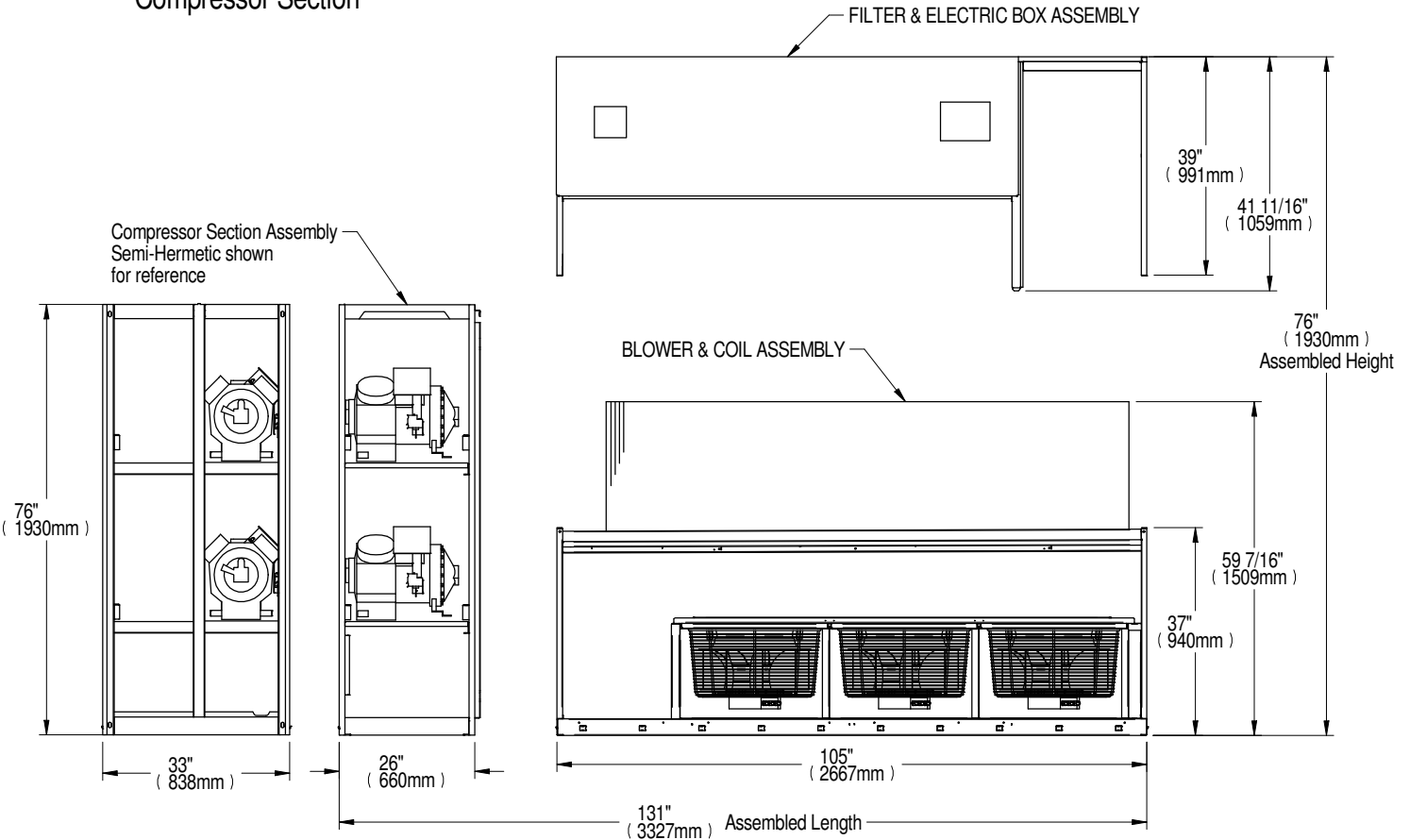

Note: Drawing Views are simplified with panels removed to show overall dimensions. See disassembly and handling instructions in installation manual.

Assembly	DRY WEIGHT lb(kg) APPROXIMATE (Includes Panels)				
	Semi-Hermetic Compressor		Scroll Compressor	Semi-Hermetic Compressor	
	Air cooled	A/C w/dual cool	Air cooled	Water/Glycol	GLYCOOL/Dual Cool
Compressor Assembly	950 (432)	950 (432)	830 (377)	1320 (600)	1320 (600)
Filter & Electric Box Assembly	270 (123)	270 (123)	270 (123)	270 (123)	270 (123)
Blower & Coil Assembly	1560 (708)	1915 (870)	1560 (708)	1560 (708)	1915 (870)

DISASSEMBLY DIMENSIONAL DATA UPFLOW 35-42kW (10-12 TONS) MODELS W/ SCROLL & DIGITAL SCROLL COMPRESSORS

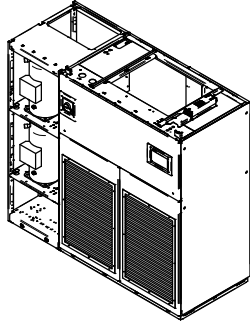

Liebert® DS Unit w/ Scroll/Digital Scroll Compressor Section

Compressor Section Assembly

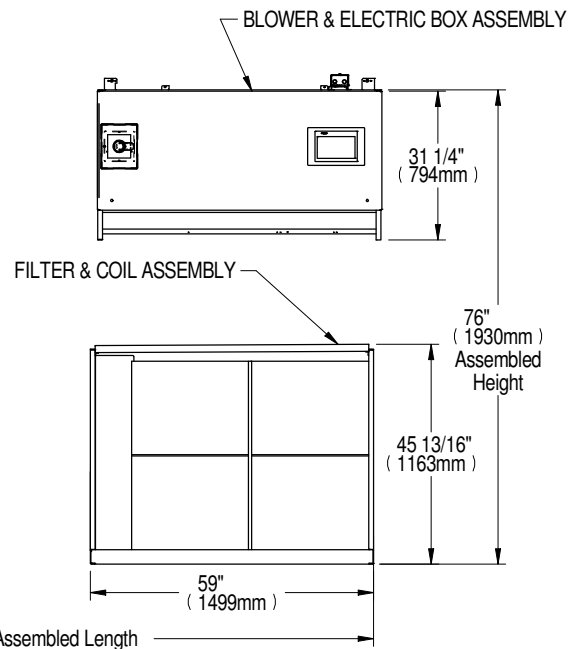
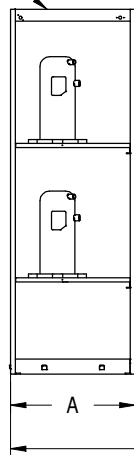
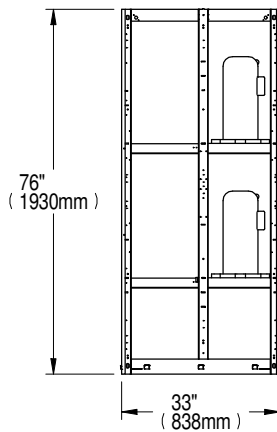

Cooling Type	A in (mm)	B in. (mm)
Air Cooled	13 (330)	72 (1829)
Air Cooled w/ Dual Cool		
Water/Glycol	26 (660)	85 (2159)
GLYCOOL/Dual Cool		

Assembly	APPROXIMATE DRY WEIGHT lb (kg) (Includes Panels)			
	Air Cooled	A/C w/ Dual Cool	Water/Glycol	GLYCOOL/Dual Cool
Compressor Assembly	490 (223)	490 (223)	800 (364)	800 (364)
Forward Curved Blower & Electric Box Assembly	510 (231)	510 (231)	510 (231)	510 (231)
EC Fan &  Electric Box Assembly	360 (163)	360 (163)	360 (163)	360 (163)
Filter & Coil Assembly	520 (236)	670 (304)	520 (236)	670 (304)

Notes:

- Drawing Views are simplified with panels removed to show overall dimensions.
See disassembly and handling instructions in installation manual. EC Fan unit shown.
-  EC Fan weight not included in this unit weight. Fan is installed in plenum. See DPN003458.
- Digital Scroll compressors not available on Air Cooled 42kW models.

DISASSEMBLY DIMENSIONAL DATA UPFLOW 53-77kW (15-22 TONS) MODELS

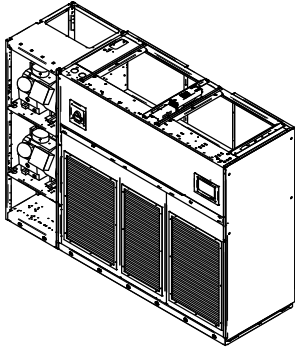

Liebert® DS Unit w/ Semi-Hermetic Compressor Section

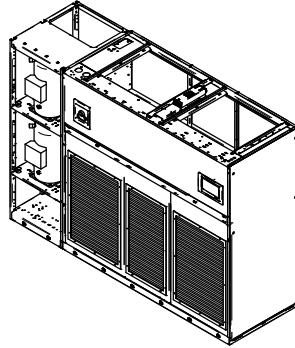

Liebert® DS Unit w/ Scroll/Digital Scroll Compressor Section

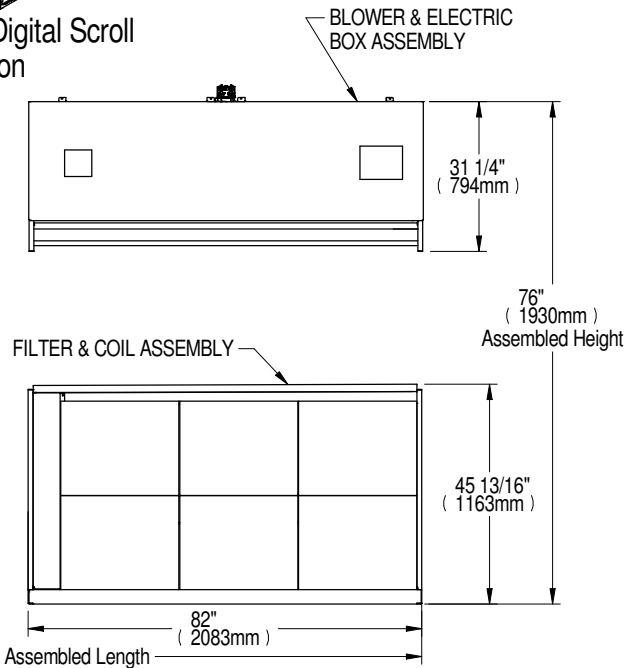
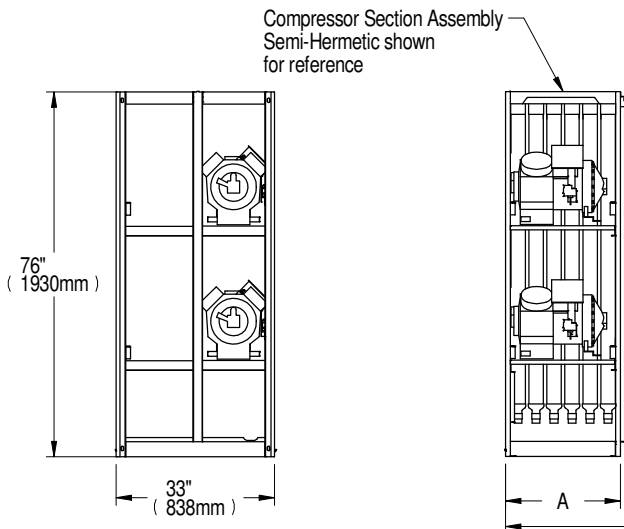

Compressor Type	Cooling Type	A in. (mm)	B in. (mm)
Scroll or Digital Scroll 4	Air Cooled	15 (381)	97 (2464)
	Air Cooled w/ Dual Cool		
	Water/Glycol GLYCOOL/Dual Cool	26 (660)	108 (2743)
Air Cooled			
Air Cooled w/ Dual Cool Water/Glycol GLYCOOL/Dual Cool			
Semi-hermetic 3			

Notes:

1. Drawing Views are simplified with panels removed to show overall dimensions. See disassembly and handling instructions in installation manual. EC Fan unit shown.
2. EC Fan weight not included in this unit weight. Fan is installed in plenum. See DPN003453.
3. Semi-Hermetic Compressor options only available on 77kW models.
4. Scroll compressors option only available on air cooled models.

Assembly	APPROXIMATE DRY WEIGHT lb (kg) (Includes Panels)							
	Semi-Hermetic Compressor 3		Scroll or Digital Scroll Compressor 4		Semi-Hermetic Compressor 3		Scroll or Digital Scroll Compressor	
	Air cooled	A/C w/ Dual Cool	Air Cooled	A/C w/ Dual Cool	Water/Glycol	GLYCOOL/Dual Cool	Water/Glycol	GLYCOOL/Dual Cool
Compressor Assembly	970 (441)	970 (441)	540 (246)	540 (246)	1270 (578)	1270 (578)	840 (382)	840 (382)
Blower & Electric Box Assembly (Forward Curved Blowers)	770 (349)	770 (349)	770 (349)	770 (349)	770 (349)	770 (349)	770 (349)	770 (349)
Blower & Electric Box Assembly (EC Fans) 2	600 (272)	600 (272)	600 (272)	600 (272)	600 (272)	600 (272)	600 (272)	600 (272)
Filter & Coil Assembly	760 (345)	940 (426)	760 (345)	940 (426)	760 (345)	940 (426)	760 (345)	940 (426)

DISASSEMBLY DIMENSIONAL DATA UPFLOW 105kW (30 TONS) MODELS

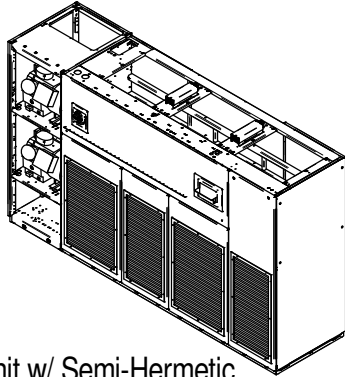

Liebert® DS Unit w/ Semi-Hermetic Compressor Section

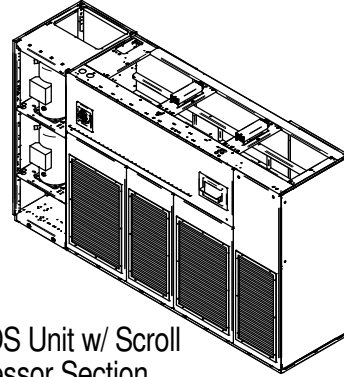

Liebert® DS Unit w/ Scroll Compressor Section

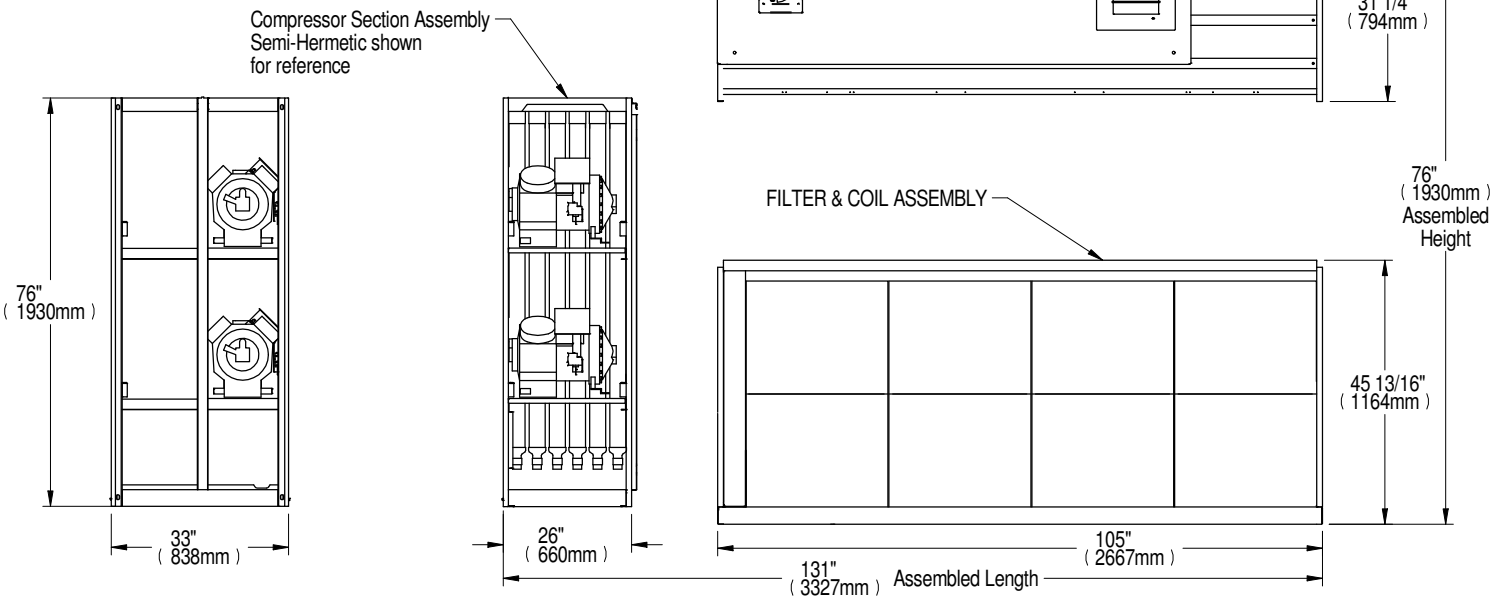

Assembly	APPROXIMATE DRY WEIGHT lb (kg) (Includes Panels)				
	Semi-Hermetic Compressor		Scroll Compressor	Semi-Hermetic Compressor	
	Air Cooled	A/C w/ Dual Cool	Air Cooled	Water/Glycol	GLYCOOL/Dual Cool
Compressor Assembly	950 (431)		830 (376)	1320 (599)	
Forward Curved Blower & Electric Box Assembly	1080 (490)		1080 (490)	1080 (490)	
EC Fans & Electric Box Assembly ²	840 (381)		840 (381)	840 (381)	
Filter & Coil Assembly	970 (440)	1300 (590)	970 (440)	970 (440)	1300 (590)

Notes:

1. Drawing Views are simplified with panels removed to show overall dimensions. See disassembly and handling instructions in installation manual. EC Fan unit shown.

² EC Fan weight not included in this unit weight. Fan is installed in plenum. See DPN003459.

Connect with Vertiv on Social Media



<https://www.facebook.com/vertiv/>



<https://www.instagram.com/vertiv/>



<https://www.linkedin.com/company/vertiv/>



<https://www.x.com/Vertiv/>



Vertiv.com | Vertiv Headquarters, 505 N. Cleveland Ave., Westerville, OH, 43082, USA

© 2026 Vertiv Group Corp. All rights reserved. Vertiv™ and the Vertiv logo are trademarks or registered trademarks of Vertiv Group Corp. All other names and logos referred to are trade names, trademarks or registered trademarks of their respective owners. While every precaution has been taken to ensure accuracy and completeness here, Vertiv Group Corp. assumes no responsibility, and disclaims all liability, for damages resulting from use of this information or for any errors or omissions.

SL-18826_REV10_05-26