

SYSTEM OVERVIEW

Description: -48 VDC Power Distribution System

The Vertiv™ NetSure™ 8100DB DC Power Distribution System is a -48 VDC Battery Distribution Fuse / Circuit Breaker Bay (BDF/CBB).

- The Vertiv™ NetSure™ 8100DB can be ordered as an 8-distribution panel or 6-distribution panel bay (4 or 3 panels per side).
- Each distribution panel can be configured for separate inputs giving you an 8-load or 6-load bay, or the panels per side can be paralleled to allow one to four feeds per side giving you a 2-load bay (may use the optional internal ground/return bar). Other configurations include an 8-panel bay with 4-loads and two loads, and a 6-panel bay with 4-loads (paralleling the top two panels or paralleling the bottom two panels per side).
- Each bay can be equipped with an optional “full bay length” internal ground/return bar (per side). Another option includes replacing one (8- and 6-panel bays) or two (8-panel bay only) distribution panels per side with a “panel length” internal ground/return bar.
- Each bay can easily be configurable for top or bottom feed.
- Each bay is equipped with a monitor unit. The monitor unit provides local and remote access to data and alarms for the voltage, current, power, and energy delivered through the distribution bay. The monitor unit contains a color TFT display and keypad for local access. The monitor unit provides an Ethernet port and comes with comprehensive webpages for remote access. The monitor unit can also be accessed via SNMP (v2 and v3), TL1 (over Ethernet), or MODBUS (over Ethernet) for remote system management. A machine-to-machine HTTP interface is also available. The monitor unit supports software upgrade via its USB port. Refer to the monitor unit instructions (UM1M832DNA) for more information.

Each bay includes an SM-DUE. The SM-DUE sends information to the monitor unit and the monitor unit monitors and displays load voltage, load current, and fuse alarm / circuit breaker alarm status of each distribution panel in the bay.

The advanced distribution panels are equipped with an SM-DUH2. The SM-DUH2 sends information to the monitor unit and the monitor unit additionally displays load voltage, load current, and fuse alarm / circuit breaker alarm status of each distribution device in the advanced distribution panel.

- Choices of distribution panels is a panel that accepts TPS / TLS and TPL-B fuses and a panel that accepts bullet nose type circuit breakers and/or bullet nose type TPS / TLS fuseholders. The bullet nose type distribution panel is available in a standard configuration or an advanced configuration. The standard configuration allows for monitoring the panel as one unit. The advance configuration also allows for monitoring each individual distribution device on the panel.

Overview Image:

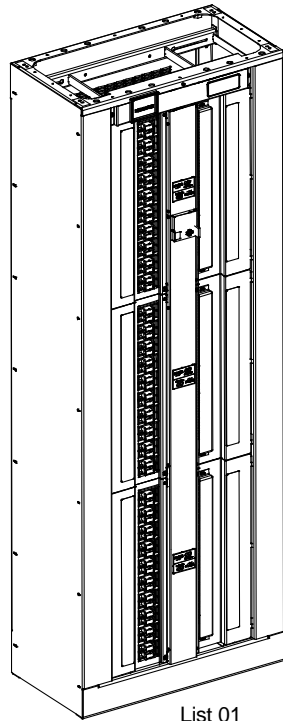

List 01
6-Panel Bay
30" W x 16" D x 84" H

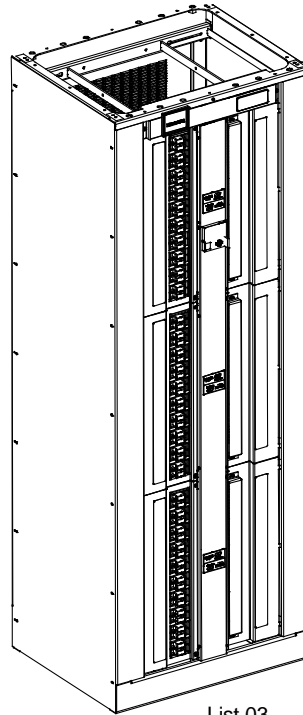

List 03
6-Panel Bay
30" W x 24" D x 84" H

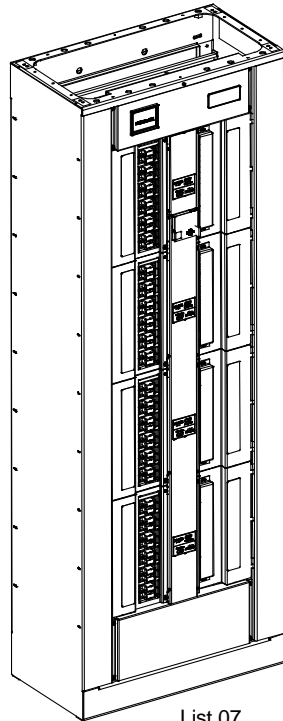

List 07
8-Panel Bay
30" W x 16" D x 84" H

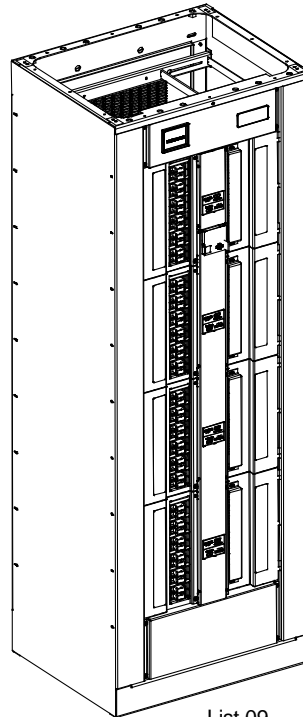

List 09
8-Panel Bay
30" W x 24" D x 84" H

Figure 1

Vertiv™ NetSure™ DC Power Distribution System

System Application Guide

General Specifications

See detailed specifications on page 58.

Family:	Vertiv™ NetSure™
Spec. No.:	582140600
Model:	8100DB
Output Voltage:	-48 VDC
Output Capacity:	640 A Continuous per Distribution Panel 8-Panel Bay; 2400 A Maximum per Side, 4800 A Maximum per Bay 6-Panel Bay; 1800 A Maximum per Side, 3600 A Maximum per Bay
Agency Approval:	UL Listed ("cULus"), NEBS (pending)
Framework Type:	Seismic Rated (Zone 4) Box Framework
6-Panel Sizes:	30" W x 16" D x 84" H 30" W x 24" D x 84" H
8-Panel Sizes:	30" W x 16" D x 84" H 30" W x 24" D x 84" H
Access:	Front and Rear for Installation, Front for Operation and Maintenance
Monitor Unit:	Microprocessor
Color:	Textured Gray
Environment:	0 °C to +40 °C (+32 °F to +104 °F)

TABLE OF CONTENTS

SYSTEM OVERVIEW 1

MAIN COMPONENTS ILLUSTRATIONS.....6

 Eight Panel Bay6

 Six Panel Bay.....8

LIST DESCRIPTIONS (582140600).....10

 List Numbers.....10

 582140600 List 01: Common Equipment, 6-Panel Bay, 30” W x 16” D x 84” H10

 582140600 List 03: Common Equipment, 6-Panel Bay, 30” W x 24” D x 84” H11

 582140600 List 07: Common Equipment, 8-Panel Bay, 30” W x 16” D x 84” H12

 582140600 List 09: Common Equipment, 8-Panel Bay, 30” W x 24” D x 84” H13

 582140600 List 10: TLS/TPS Fuse and/or TPL-B Fuse Distribution Panel, 8-Panel Bay.....14

 582140600 List 15: Bullet Breaker and/or TLS/TPS Fuse Distribution Panel, 8-Panel Bay.....14

 582140600 List 15A: Advanced Bullet Breaker and/or TLS/TPS Fuse Distribution Panel with Individual Current
 Monitoring, 8-Panel Bay15

 582140600 List 16: Optional Internal Ground/Return Bar, 8-Panel Bay (Full Bay Length).....15

 582140600 List 17: Optional Internal Ground/Return Bar, 8-Panel Bay (Panel Length).....16

 582140600 List 18: Blank Distribution Panel Cover, 8-Panel Bay16

 582140600 List 20: TLS/TPS Fuse and/or TPL-B Fuse Distribution Panel, 6-Panel Bay17

 582140600 List 25: Bullet Breaker and/or TLS/TPS Fuse Distribution Panel, 6-Panel Bay.....17

 582140600 List 25A: Advanced Bullet Breaker and/or TLS/TPS Fuse Distribution Panel with Individual Current
 Monitoring, 6-Panel Bay18

 582140600 List 26: Optional Internal Ground/Return Bar, 6-Panel Bay (Full Bay Length)18

 582140600 List 27: Optional Internal Ground/Return Bar, 6-Panel Bay (Panel Length).....19

 582140600 List 28: Blank Distributional Panel Cover, 6-Panel Bay.....19

 582140600 List 30: Distribution Panel Paralleling Bar, 6-Panel Bay.....20

 582140600 List 31: Distribution Panel Paralleling Bar, 8-Panel Bay20

 582140600 List 39: Optional Internal Ground/Return Bar Paralleling Kit, 8-Panel Bay (Panel Length)20

 582140600 List 43: Bay Input Feed and Shunt Assembly (4 Cables, 25 mV Shunts).....20

 582140600 List 48: 2400 A Ground/Return Input Assembly, with Optional Bonding Strap21

 582140600 List 51: Dressing Bar, 16” Deep Bays21

 582140600 List 52: Dressing Bar, 24” Deep Bays.....21

 582140600 List 53: Load Distribution Cable Management Kit22

 582140600 List 54: Top Cover, 16” Deep22

 582140600 List 55: Top Cover, 24” Deep22

 582140600 List 67: Pre-Installed Load Lug-Mounting Hardware.....22

ACCESSORY DESCRIPTIONS 23

 Load Lug Hardware Kits, P/N 547682 and 547683 23

 Side by Side Distribution Panel Paralleling Bar, P/N 563497 23

 Distribution Device Numbering Scheme Reversing Kit, P/N 565436 and 565437 24

 Lug Adaptor Kits..... 25

 P/Ns 556377 and 55637825

 P/Ns 564906 and 564907.....26

 Special Lugs and Adapters.....27

 External Return/Ground Bar Assemblies 28

 Standard Crimp Lug Tables 29

 Seismic Anchor Kit, P/N 545387 30

 Transient Voltage Surge Suppressor (TVSS) Device 30

 Distribution Devices and Lug Selection..... 31

 List 10 and List 20 Fuse Panels31

 List 15, List 15A, List 25, and List 25A Fuse/Circuit Breaker Panels.....35

 User Replaceable Alarm, Reference, and Control Fuses 39

 Fuses Located on Auxiliary Fuse Card at Top of Bay39

 User Replaceable Components..... 39

RECOMMENDED WIRE SIZES, BRANCH CIRCUIT PROTECTION, CRIMP LUGS, AND WIRING ILLUSTRATIONS..... 40

 Overall Installer’s Connections Illustration 40

Vertiv™ NetSure™ DC Power Distribution System

System Application Guide

Bay Frame Grounding Requirements	41
General	41
Bay Frame Grounding Connection	41
Auxiliary Fuse Circuit Card	42
Monitor Unit Ethernet Connection (if required)	43
To Monitor Unit	43
To IB5 Board	43
Load Distribution Connections	44
General	44
Load Distribution Connections Illustrations	48
DC Input Connections	54
General	54
DC Input Connections	55
SPECIFICATIONS	58
1. System	58
1.1 DC Operating Voltage	58
1.2 Environmental Ratings	58
1.3 Compliance Information	58
1.4 Output Ratings	58
1.5 Standard Features	58
2. Monitor Unit	59
MECHANICAL SPECIFICATIONS	60
List 01 and List 07 Floor Hole Drilling Pattern Dimensions	60
List 03 and List 09 Floor Hole Drilling Pattern Dimensions	60
Overall Dimensions, List 01	61
Overall Dimensions, List 03	62
Overall Dimensions, List 07	63
Overall Dimensions, List 09	64
Weights	65
RELATED DOCUMENTATION	66

MAIN COMPONENTS ILLUSTRATIONS

Eight Panel Bay

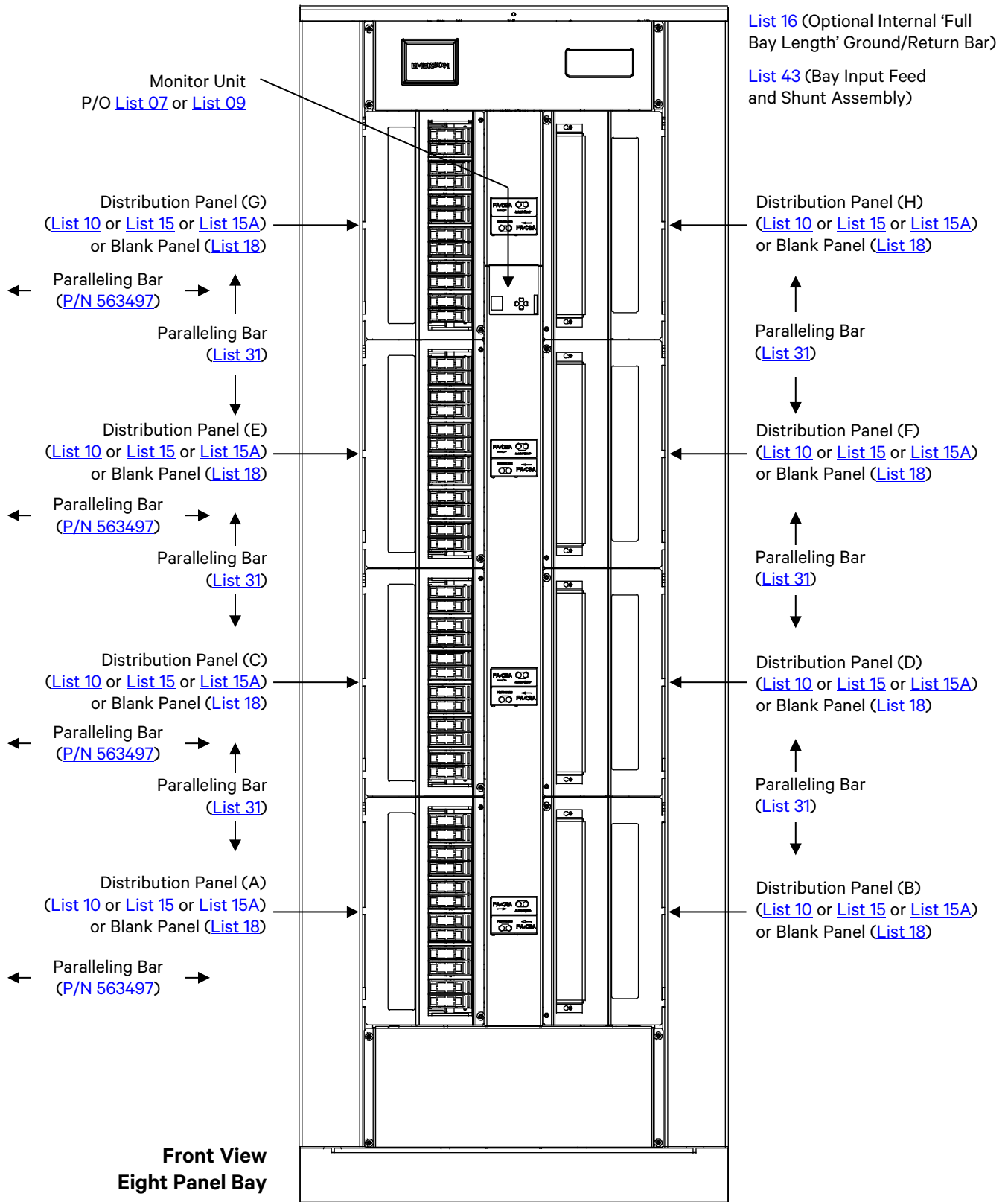

[List 07](#) or [List 09](#)

(Common Equipment)

[List 16](#) (Optional Internal 'Full Bay Length' Ground/Return Bar)

[List 43](#) (Bay Input Feed and Shunt Assembly)

Eight Panel Bay (cont'd)

OTHER OPTIONS

[List 17](#) (Optional Internal 'Panel Length' Ground/Return Bar)

[List 39](#) (Optional Internal 'Panel Length' Ground/Return Bar Paralleling Kit)

[List 48](#) (2400 A Ground/Return Input Assembly,
with Optional Bonding Strap for [List 16](#) Ground/Return Bar)

[List 51](#) and [List 52](#) (Cable Dressing Bar)

[List 53](#) (Load Distribution Cable Management Kit)

[List 54](#) (Top Cover, 16" Deep)

[List 55](#) (Top Cover, 24" Deep)

[List 67](#) (Pre-Installed Load Lug Hardware)

Six Panel Bay

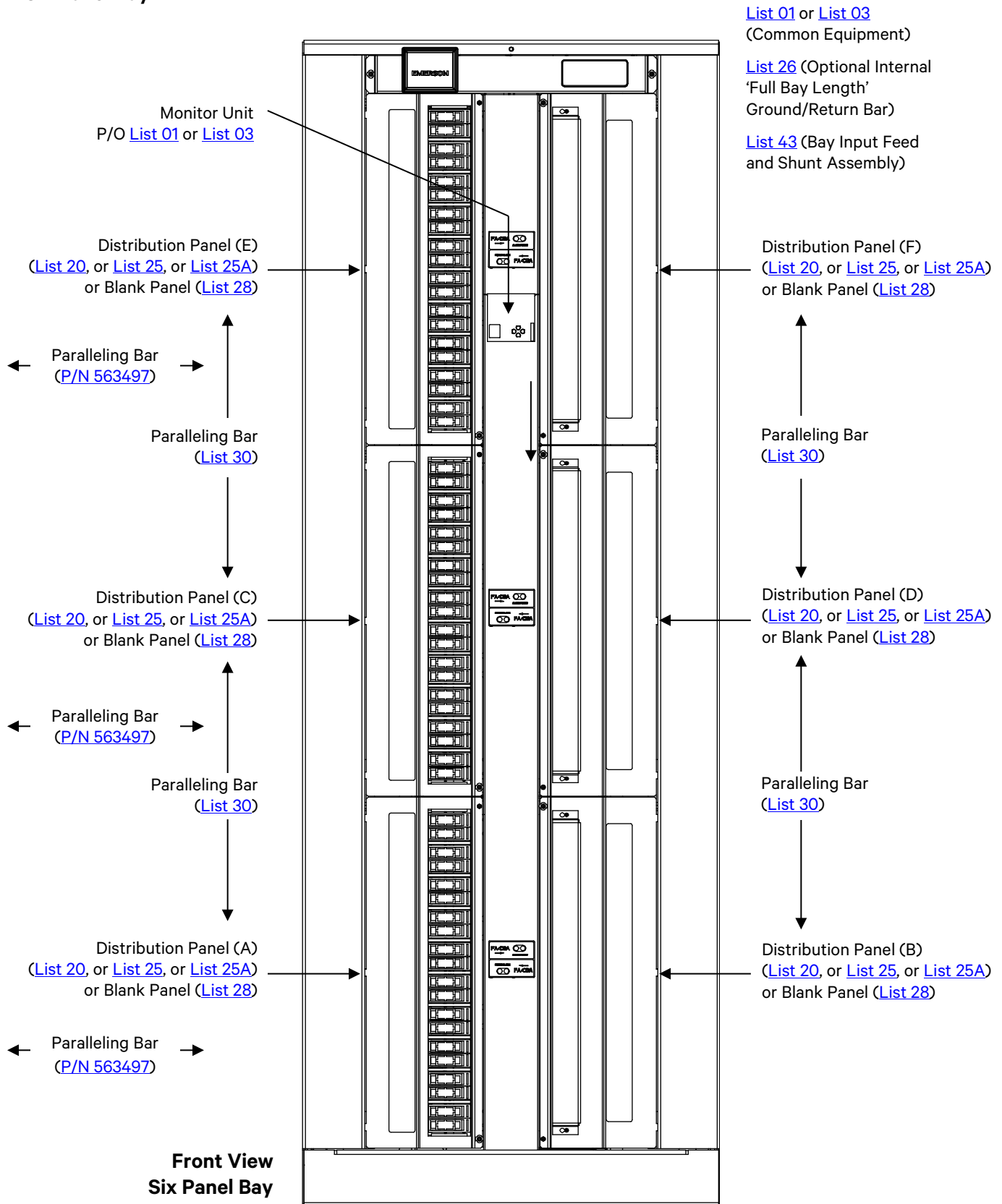

Six Panel Bay (cont'd)

OTHER OPTIONS

[List 27](#) (Optional Internal 'Panel Length' Ground/Return Bar)

[List 39](#) (Optional Internal 'Panel Length' Ground/Return Bar Paralleling Kit)

[List 48](#) (2400A Ground/Return Input Assembly, with Optional Bonding Strap for [List 26](#) Ground/Return Bar)

[List 51](#) and [List 52](#) (Cable Dressing Bar)

[List 53](#) (Load Distribution Cable Management Kit)

[List 54](#) (Top Cover, 16" Deep)

[List 55](#) (Top Cover, 24" Deep)

[List 67](#) (Pre-Installed Load Lug Hardware)

LIST DESCRIPTIONS (582140600)

List Numbers

582140600 List 01: Common Equipment, 6-Panel Bay, 30" W x 16" D x 84" H

Features

- ◆ List 01 provides the common equipment for a 6-distribution panel BDF/CBB (Battery Distribution Fuse/Circuit Breaker Bay).
- ◆ Configurable for top or bottom feed.
- ◆ Consists of a 30" W x 16" D x 84" H welded box framework (seismic, zone 4 earthquake compliant).
- ◆ Includes Monitor Unit Model M832DNA.
- ◆ Includes an IB5 board (second Ethernet port for the monitor unit). The Ethernet port located on the monitor unit can be used to connect a computer directly to the monitor unit. The Ethernet port located on the IB5 board can be used to connect the monitor unit to your Local Area Network (LAN).



NOTE! IB5 boards with a 10M/100M/1G Ethernet port replaced IB4 boards with a 10M/100M Ethernet port. This transition enables the support of connected devices that communicate up to 1G. While both boards are physically interchangeable, the IB5 board does require the NCU to have V1.2.80 or higher software loaded.

- ◆ Includes connection points for four (4) fused auxiliary -48V power outputs (1-1/3A) and fused remote (A/B) electronics inputs.

Restrictions

You can vertical parallel along with side by side parallel but the limitation is that you can use only one (1) of P/N 563497 per set of panels tied together and it must be installed on the bottom set of panels of the set in a top feed and top set of panels of the set on a bottom feed.

Ordering Notes

- 1) Order up to six (6) Lists 20 (see page 17), List 25 (see page 17), and/or List 25A (see page 18) distribution panels per bay.
 - a) Order fuses and/or circuit breakers as required per "Distribution Devices and Lug Selection" on page 31.
 - b) Order load distribution lugs as required per "Distribution Devices and Lug Selection" on page 31.
 - c) For load and load return lug-mounting hardware, order load lug hardware kits (ship-loose) (see page 23) as required, or order List 67 (pre-installed) (see page 22).
 - d) For any open distribution panel position, order a List 28 blank panel (see page 19).
- 2) If distribution panels (per side) are to be paralleled, order a List 30 distribution panel paralleling bar (see page 20). Each List 30 includes two (2) paralleling bars (one per side).
- 3) If distribution panels (side by side) are to be paralleled, order P/N 563497 distribution panel paralleling bar (see page 23).
- 4) Order List 43 input feed and shunt assembly as required (see page 20). Each List 43 provides input terminations and shunts for both sides.

For top and bottom feed 2-load applications, order one (1) List 43 and specify top or bottom feed.

For top and bottom feed multi-load applications, order three (3) List 43 for each side A / side B load and specify top or bottom feed.

List 20 Only: For 3-load side by side applications, order three (3) List 43, and order three (3) P/N 563497.

List 25 and List 25A Only: For 3-load side by side applications, order three (3) List 43, and order three (3) P/N 563497.
- 5) Order DC input lugs as required (see "DC Input Connections" on page 54).
- 6) Order bay frame grounding lugs as required (see page "Bay Frame Grounding Requirements" on page 41).
- 7) Order List 26 (see page 18) or List 27 (see page 19) internal ground bars as required, or use external ground bars as required (see page 28).
- 8) List 26 provides input lug landing points at the top or bottom (as specified) of the full bay length ground/return busbars. List 26 internal return bars are rated for 1200 A. List 48 (see page 21) is available to increase that capacity to 2400 A and provide additional cable landing points. Each bay can accommodate (1) List 48. List 48 offers cable termination at the rear of the bay and the option of a bonding strap.
- 9) Order List 51 cable dressing bars (see page 21) or List 53 load distribution cable management kit (see page 22) as required.
- 10) Order List 54 top cover (see page 22) as required.
- 11) Order TVSS device(s) as required (see page 30).

Vertiv™ NetSure™ DC Power Distribution System

System Application Guide

582140600 List 03: Common Equipment, 6-Panel Bay, 30" W x 24" D x 84" H

Features

- ◆ List 03 provides the common equipment for a 6-distribution panel BDF/CBB (Battery Distribution Fuse/Circuit Breaker Bay).
- ◆ Configurable for top or bottom feed.
- ◆ Consists of a 30" W x 24" D x 84" H welded box framework (seismic, zone 4 earthquake compliant).
- ◆ Includes Monitor Unit Model M832DNA.
- ◆ Includes an IB5 board (second Ethernet port for the monitor unit). The Ethernet port located on the monitor unit can be used to connect a computer directly to the monitor unit. The Ethernet port located on the IB5 board can be used to connect the monitor unit to your Local Area Network (LAN).



NOTE! *IB5 boards with a 10M/100M/1G Ethernet port replaced IB4 boards with a 10M/100M Ethernet port. This transition enables the support of connected devices that communicate up to 1G. While both boards are physically interchangeable, the IB5 board does require the NCU to have V1.2.80 or higher software loaded.*

- ◆ Includes connection points for four (4) fused auxiliary -48V power outputs (1-1/3A) and fused remote (A/B) electronics inputs.

Restrictions

You can vertical parallel along with side by side parallel but the limitation is that you can use only one (1) of P/N 563497 per set of panels tied together and it must be installed on the bottom set of panels of the set in a top feed and top set of panels of the set on a bottom feed.

Ordering Notes

- 1) Order up to six (6) Lists 20 (see page 17), List 25 (see page 17), and/or List 25A (see page 18) distribution panels per bay.
 - a) Order fuses and/or circuit breakers as required per "Distribution Devices and Lug Selection" on page 31.
 - b) Order load distribution lugs as required per "Distribution Devices and Lug Selection" on page 31.
 - c) For load and load return lug-mounting hardware, order load lug hardware kits (ship-loose) (see page 23) as required, or order List 67 (pre-installed) (see page 22).
 - d) For any open distribution panel position, order a List 28 blank panel (see page 19).
- 2) If distribution panels (per side) are to be paralleled, order a List 30 distribution panel paralleling bar (see page 20). Each List 30 includes two (2) paralleling bars (one per side).
- 3) If distribution panels (side by side) are to be paralleled, order P/N 563497 distribution panel paralleling bar (see page 23).
- 4) Order List 43 input feed and shunt assembly as required (see page 20). Each List 43 provides input terminations and shunts for both sides.

For top and bottom feed 2-load applications, order one (1) List 43 and specify top or bottom feed.

For top and bottom feed multi-load applications, order three (3) List 43 for each side A / side B load and specify top or bottom feed.

List 20 Only: For 3-load side by side applications, order three (3) List 43, and order three (3) P/N 563497.

List 25 and List 25A Only: For 3-load side by side applications, order three (3) List 43, and order three (3) 563497.
- 5) Order DC input lugs as required (see "DC Input Connections" on page 54).
- 6) Order bay frame grounding lugs as required (see page "Bay Frame Grounding Requirements" on page 41).
- 7) Order List 26 (see page 18) or List 27 (see page 19) internal ground bars as required, or use external ground bars as required (see page 28).
- 8) List 26 provides input lug landing points at the top or bottom (as specified) of the full bay length ground/return busbars. List 26 internal return bars are rated for 1200 A. List 48 (see page 21) is available to increase that capacity to 2400 A and provide additional cable landing points. Each bay can accommodate (1) List 48. List 48 offers cable termination at the rear of the bay and the option of a bonding strap.
- 9) Order List 52 cable dressing bars (see page 21) or List 53 load distribution cable management kit (see page 22) as required.
- 10) Order List 55 top cover (see page 22) as required.
- 11) Order TVSS device(s) as required (see page 30).

Vertiv™ NetSure™ DC Power Distribution System

System Application Guide

582140600 List 07: Common Equipment, 8-Panel Bay, 30" W x 16" D x 84" H

Features

- ◆ List 07 provides the common equipment for a 8-distribution panel BDF/CBB (Battery Distribution Fuse/Circuit Breaker Bay).
- ◆ Configurable for top or bottom feed.
- ◆ Consists of a 30" W x 16" D x 84" H welded box framework (seismic, zone 4 earthquake compliant).
- ◆ Includes Monitor Unit Model M832DNA.
- ◆ Includes an IB5 board (second Ethernet port for the monitor unit). The Ethernet port located on the monitor unit can be used to connect a computer directly to the monitor unit. The Ethernet port located on the IB5 board can be used to connect the monitor unit to your Local Area Network (LAN).



NOTE! *IB5 boards with a 10M/100M/1G Ethernet port replaced IB4 boards with a 10M/100M Ethernet port. This transition enables the support of connected devices that communicate up to 1G. While both boards are physically interchangeable, the IB5 board does require the NCU to have V1.2.80 or higher software loaded.*

- ◆ Includes connection points for four (4) fused auxiliary -48V power outputs (1-1/3A) and fused remote (A/B) electronics inputs.

Restrictions

You can vertical parallel along with side by side parallel but the limitation is that you can use only one (1) of P/N 563497 per set of panels tied together and it must be installed on the bottom set of panels of the set in a top feed and top set of panels of the set on a bottom feed.

Ordering Notes

- 1) Order up to eight (8) Lists 10 (see page 14), List 15 (see page 14), and/or List 15A (see page 15) distribution panels per bay.
 - a) Order fuses and/or circuit breakers as required per "Distribution Devices and Lug Selection" on page 31.
 - b) Order load distribution lugs as required per "Distribution Devices and Lug Selection" on page 31.
 - c) For load and load return lug-mounting hardware, order load lug hardware kits (ship-loose) (see page 23) as required, or order List 67 (pre-installed) (see page 22).
 - d) For any open distribution panel position, order a List 18 blank panel (see page 16).
- 2) If distribution panels (per side) are to be paralleled, order a List 31 distribution panel paralleling bar (see page 20). Each List 31 includes two (2) paralleling bars (one per side).
- 3) If distribution panels (side by side) are to be paralleled, order P/N 563497 distribution panel paralleling bar (see page 23).
- 4) Order List 43 input feed and shunt assembly as required (see page 20). Each List 43 provides input terminations and shunts for both sides.

For top and bottom feed 2-load applications, order one (1) List 43 and specify top or bottom feed.

For top and bottom feed multi-load applications, order two (2) or four (4) List 43 for each Side A/Side B load and specify top or bottom feed. Order List 31 as required.

List 10 Only: For 4-load side by side applications, order four (4) List 43, and order four (4) P/N 563497. For top and bottom feed 2-load side by side applications, order two (2) List 43, two (2) P/N 563497, and two (2) List 31.

List 15 and 15A Only: For 4-load side by side applications, order four (4) List 43, and order four (4) 563497. For top and bottom feed 2-load side by side applications, order two (2) List 43, two (2) 563497, and two (2) List 31.
- 5) Order DC input lugs as required (see "DC Input Connections" on page 54).
- 6) Order bay frame grounding lugs as required (see page "Bay Frame Grounding Requirements" on page 41).
- 7) Order List 16 (see page 15) or List 17 (see page 16) internal ground bars as required, or use external ground bars as required (see page 28).
- 8) List 16 provides input lug landing points at the top or bottom (as specified) of the full bay length ground/return busbars. List 16 internal return bars are rated for 1200 A. List 48 (see page 21) is available to increase that capacity to 2400 A and provide additional cable landing points. Each bay can accommodate (1) List 48. List 48 offers cable termination at the rear of the bay and the option of a bonding strap.
- 9) Order List 51 cable dressing bars (see page 21) or List 53 load distribution cable management kit (see page 22) as required.
- 10) Order List 54 top cover (see page 22) as required.
- 11) Order TVSS device(s) as required (see page 30).

Vertiv™ NetSure™ DC Power Distribution System

System Application Guide

582140600 List 09: Common Equipment, 8-Panel Bay, 30" W x 24" D x 84" H

Features

- ◆ List 09 provides the common equipment for a 8-distribution panel BDF/CBB (Battery Distribution Fuse/Circuit Breaker Bay).
- ◆ Configurable for top or bottom feed.
- ◆ Consists of a 30" W x 24" D x 84" H welded box framework (seismic, zone 4 earthquake compliant).
- ◆ Includes Monitor Unit Model M832DNA.
- ◆ Includes an IB5 board (second Ethernet port for the monitor unit). The Ethernet port located on the monitor unit can be used to connect a computer directly to the monitor unit. The Ethernet port located on the IB5 board can be used to connect the monitor unit to your Local Area Network (LAN).



NOTE! *IB5 boards with a 10M/100M/1G Ethernet port replaced IB4 boards with a 10M/100M Ethernet port. This transition enables the support of connected devices that communicate up to 1G. While both boards are physically interchangeable, the IB5 board does require the NCU to have V1.2.80 or higher software loaded.*

- ◆ Includes connection points for four (4) fused auxiliary -48V power outputs (1-1/3A) and fused remote (A/B) electronics inputs.

Restrictions

You can vertical parallel along with side by side parallel but the limitation is that you can use only one (1) of P/N 563497 per set of panels tied together and it must be installed on the bottom set of panels of the set in a top feed and top set of panels of the set on a bottom feed.

Ordering Notes

- 1) Order up to eight (8) Lists 10 (see page 14), List 15 (see page 14), and/or List 15A (see page 15) distribution panels per bay.
 - a) Order fuses and/or circuit breakers as required per "Distribution Devices and Lug Selection" on page 31.
 - b) Order load distribution lugs as required per "Distribution Devices and Lug Selection" on page 31.
 - c) For load and load return lug-mounting hardware, order load lug hardware kits (ship-loose) (see page 23) as required, or order List 67 (pre-installed) (see page 22).
 - d) For any open distribution panel position, order a List 28 blank panel (see page 19).
- 2) If distribution panels (per side) are to be paralleled, order a List 31 distribution panel paralleling bar (see page 20). Each List 31 includes two (2) paralleling bars (one per side).
- 3) If distribution panels (side by side) are to be paralleled, order P/N 563497 distribution panel paralleling bar (see page 23).
- 4) Order List 43 input feed and shunt assembly as required (see page 20). Each List 43 provides input terminations and shunts for both sides.

For top and bottom feed 2-load applications, order one (1) List 43 and specify top or bottom feed.

For top and bottom feed multi-load applications, order two (2) or four (4) List 43 for each Side A/Side B load and specify top or bottom feed. Order List 31 as required.

List 10 Only: For 4-load side by side applications, order four (4) List 43, and order four (4) P/N 563497. For top and bottom feed 2-load side by side applications, order two (2) List 43, two (2) P/N 563497, and two (2) List 31.

List 15 and 15A Only: For 4-load side by side applications, order four (4) List 43, and order four (4) 563497. For top and bottom feed 2-load side by side applications, order two (2) List 43, two (2) 563497, and two (2) List 31.
- 5) Order DC input lugs as required (see "DC Input Connections" on page 54).
- 6) Order bay frame grounding lugs as required (see page "Bay Frame Grounding Requirements" on page 41).
- 7) Order List 16 (see page 15) or List 17 (see page 16) internal ground bars as required, or use external ground bars as required (see page 28).
- 8) List 16 provides input lug landing points at the top or bottom (as specified) of the full bay length ground/return busbars. List 16 internal return bars are rated for 1200 A. List 48 (see page 21) is available to increase that capacity to 2400 A and provide additional cable landing points. Each bay can accommodate (1) List 48. List 48 offers cable termination at the rear of the bay and the option of a bonding strap.
- 9) Order List 52 cable dressing bars (see page 21) or List 53 load distribution cable management kit (see page 22) as required.
- 10) Order List 55 top cover (see page 22) as required.
- 11) Order TVSS device(s) as required (see page 30).

582140600 List 10: TLS/TPS Fuse and/or TPL-B Fuse Distribution Panel, 8-Panel Bay

Features

- ◆ Twelve (12) TLS/TPS fuse positions, or six (6) TPL-B fuse positions, or a combination of TLS/TPS and TPL-B fuse positions.
- ◆ Includes twelve (12) TLS/TPS fuseholders P/N 248817100. For panels **factory** configured in a bay, each TPL-B fuseholder P/N 516241 ordered replaces two (2) P/N 248817100 fuseholders.
- ◆ See “Load Distribution Connections” starting on page 44 for load termination specifications.
- ◆ Distribution panel is monitored for load voltage, load current, and fuse alarm status per panel.

Restrictions

640 A maximum continuous.
For use in List 07 and List 09.

Ordering Notes

- 1) Order as required.
- 2) Specify up to twelve (12) TLS/TPS fuseholders, or up to six (6) TPL-B fuseholders, or a combination per distribution panel (all positions **MUST** be filled). This instructs the factory how to configure the distribution panel. Also specify mounting location for each configured distribution panel per bay. This instructs the factory where to mount each configured distribution panel per bay.
- 3) Order fuses and lugs as required per “Distribution Devices and Lug Selection” on page 31.
- 4) Replacement panels will be equipped with twelve (12) TLS/TPS fuseholders. TPL-B fuseholders (P/N 516241) may be ordered to field modify the distribution panel. One (1) TPL-B fuseholder takes the space of two (2) TLS/TPS fuseholders.

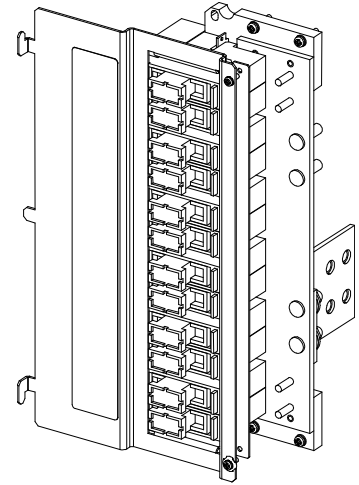

582140600 List 15: Bullet Breaker and/or TLS/TPS Fuse Distribution Panel, 8-Panel Bay

Features

- ◆ Sixteen (16) bullet nose circuit breaker and/or TLS/TPS fuse (with bullet nose fuseholder) positions.
- ◆ See “Load Distribution Connections” starting on page 44 for load termination specifications.
- ◆ Distribution panel is monitored for load voltage, load current, and fuse / circuit breaker alarm status per panel.

Restrictions

640 A maximum continuous.
For use in List 07 and List 09.

Ordering Notes

- 1) Order as required.
- 2) Specify mounting location for each distribution panel per bay. This instructs the factory where to mount each distribution panel when the bay is populated with different types of distribution panels.
- 3) Order distribution fuses, fuseholders, circuit breakers, and load lugs as required per “Distribution Devices and Lug Selection” on page 31.

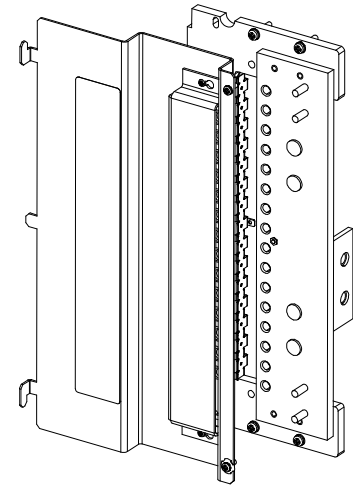

582140600 List 15A: Advanced Bullet Breaker and/or TLS/TPS Fuse Distribution Panel with Individual Current Monitoring, 8-Panel Bay

Features

- ◆ Sixteen (16) bullet nose circuit breaker and/or TLS/TPS fuse (with bullet nose fuseholder) positions with advanced monitoring.
- ◆ Individual circuit breaker and/or TLS/TPS fuse current monitoring including; Power, Energy, and FA/CB alarm per position.
- ◆ See “Load Distribution Connections” starting on page 44 for load termination specifications.
- ◆ Distribution panel is monitored for load voltage, load current, and fuse / circuit breaker alarm status per panel and per distribution device.

Restrictions

640 A maximum continuous.
For use in List 07 and List 09.

Ordering Notes

- 1) Order as required.
- 2) Specify mounting location for each distribution panel per bay. This instructs the factory where to mount each distribution panel when the bay is populated with different types of distribution panels.
- 3) Order distribution fuses, fuseholders, circuit breakers, and load lugs as required per “Distribution Devices and Lug Selection” on page 31.

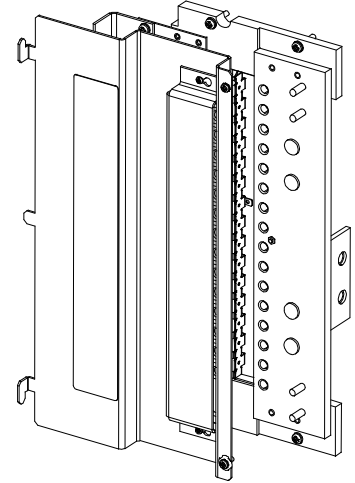

582140600 List 16: Optional Internal Ground/Return Bar, 8-Panel Bay (Full Bay Length)

Features

- ◆ Provides two (2) full bay length internal ground/return bars (one per side).
- ◆ See “Load Distribution Connections” starting on page 44 for load termination specifications.
- ◆ Includes two (2) input lug landing plate assemblies (one per side).
- ◆ Can be configured for top or bottom feed.

Restrictions

For use in List 07 and List 09.

Ordering Notes

- 1) Order as required.
- 2) Specify mounting location of included input lug landing plate assemblies: Top for top-feed or bottom for bottom feed.
- 3) List 16 internal ground/return bars are rated for 1200 A. List 48 is available to increase that capacity to 2400 A and provide additional cable landing points. Each bay can accommodate one (1) List 48. List 48 offers cable termination at the rear of the bay and the option of a bonding strap. Mounting location (top or bottom) of List 48 will be opposite that specified for the input lug landing plate assemblies of List 16.
- 4) Order load lugs as required per “Distribution Devices and Lug Selection” on page 31.

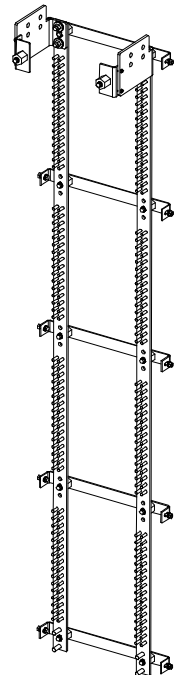

582140600 List 17: Optional Internal Ground/Return Bar, 8-Panel Bay (Panel Length)

Features

- ◆ Replaces a distribution panel on the left and right side with a panel length internal ground/return bar.
- ◆ Consists of two (2) ground/return bar assemblies and two (2) blank cover panels.
- ◆ For installation in top feed or bottom feed arrangements. When used in top feed arrangements, ground bar assemblies are installed in top most left and right distribution panel mounting positions (appropriate blank cover panels are also installed in these positions). When used in bottom feed arrangements, ground bar assemblies are installed in bottom most left and right distribution panel mounting positions (appropriate blank cover panels are also installed in these positions). When an additional List 17 is ordered, these additional ground bar assemblies are installed in the adjacent distribution panel mounting positions (appropriate blank cover panels are supplied and installed in these positions).
- ◆ See “Load Distribution Connections” starting on page 44 for load termination specifications.
- ◆ See List 39 on page 20 for a paralleling kit when two (2) List 17 are ordered for the same bay.

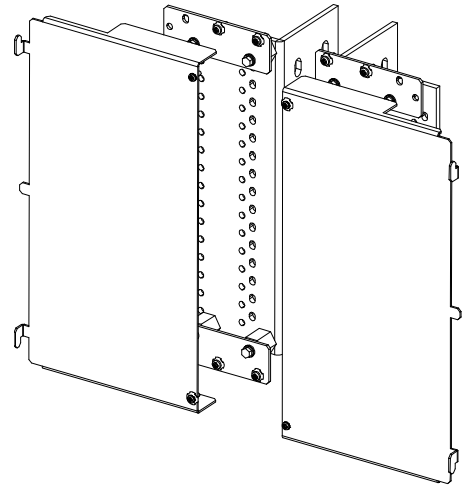

Restrictions

For use in List 07 and List 09.

Ordering Notes

- 1) Order as required. Order two (2) List 17 for a fully configured bay. Also order one (1) List 39 paralleling kit if two (2) List 17 are ordered.
- 2) Specify top feed or bottom feed to instruct the factory to mount the internal ground/return bars at the top or bottom of the bay.
- 3) Order load lugs as required per “Distribution Devices and Lug Selection” on page 31.

582140600 List 18: Blank Distribution Panel Cover, 8-Panel Bay

Features

- ◆ Covers an unused distribution panel position.

Restrictions

For use in List 07 and List 09.

Ordering Notes

- 1) Order one (1) List 18 for each position in a List 07 or List 09 bay that is NOT populated with a distribution panel.

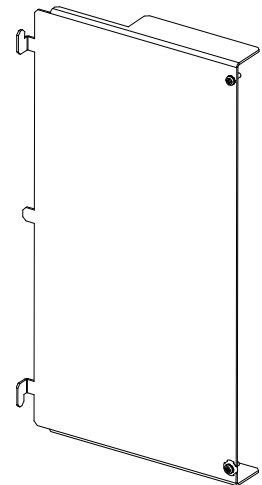

582140600 List 20: TLS/TPS Fuse and/or TPL-B Fuse Distribution Panel, 6-Panel Bay

Features

- ◆ Twenty (20) TLS/TPS fuse positions, or ten (10) TPL-B fuse positions, or a combination of TLS/TPS and TPL-B fuse positions.
- ◆ Includes twenty (20) TLS/TPS fuseholders P/N 248817100. For panels **factory** configured in a bay, each TPL-B fuseholder P/N 516241 ordered replaces two (2) P/N 248817100 fuseholders.
- ◆ See “Load Distribution Connections” starting on page 44 for load termination specifications.
- ◆ Distribution panel is monitored for load voltage, load current, and fuse / circuit breaker alarm status per panel.

Restrictions

640 A maximum continuous.
For use in List 01 and List 03.

Ordering Notes

- 1) Order as required.
- 2) Specify twenty (20) TLS/TPS fuseholders, or up to ten (10) TPL-B fuseholders, or a combination per distribution panel (all positions **MUST** be filled). This instructs the factory how to configure the distribution panel. Also specify mounting location for each configured distribution panel per bay. This instructs the factory where to mount each configured distribution panel per bay.
- 3) Order fuses and lugs as required per “Distribution Devices and Lug Selection” on page 31.
- 4) Replacement panels will be equipped with twenty (20) TLS/TPS fuseholders. TPL-B fuseholders (P/N 516241) may be ordered to field modify the distribution panel. One (1) TPL-B fuseholder takes the space of two (2) TLS/TPS fuseholders.

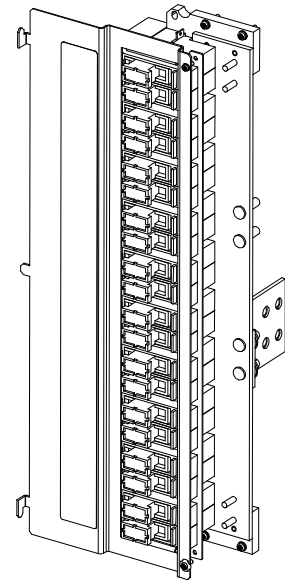

582140600 List 25: Bullet Breaker and/or TLS/TPS Fuse Distribution Panel, 6-Panel Bay

Features

- ◆ Twenty-eight (28) bullet nose circuit breaker and/or TLS/TPS fuse (with bullet nose fuseholder) positions.
- ◆ See “Load Distribution Connections” starting on page 44 for load termination specifications.
- ◆ Distribution panel is monitored for load voltage, load current, and fuse / circuit breaker alarm status per panel.

Restrictions

640 A maximum continuous.
For use in List 01 and List 03.

Ordering Notes

- 1) Order as required.
- 2) Specify mounting location for each distribution panel per bay. This instructs the factory where to mount each distribution panel when the bay is populated with different types of distribution panels.
- 3) Order distribution fuses, fuseholders, circuit breakers, and load lugs as required per “Distribution Devices and Lug Selection” on page 31.

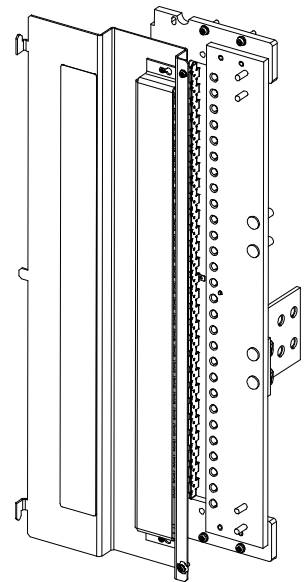

Vertiv™ NetSure™ DC Power Distribution System

System Application Guide

582140600 List 25A: Advanced Bullet Breaker and/or TLS/TPS Fuse Distribution Panel with Individual Current Monitoring, 6-Panel Bay

Features

- ◆ Twenty-eight (28) bullet nose circuit breaker and/or TLS/TPS fuse (with bullet nose fuseholder) positions with advanced monitoring.
- ◆ Individual circuit breaker and/or TLS/TPS fuse current monitoring including; Power, Energy, and FA/CB alarm per position.
- ◆ See “Load Distribution Connections” starting on page 44 for load termination specifications.
- ◆ Distribution panel is monitored for load voltage, load current, and fuse / circuit breaker alarm status per panel and per distribution device.

Restrictions

640 A maximum continuous.
For use in List 01 and List 03.

Ordering Notes

- 1) Order as required.
- 2) Specify mounting location for each distribution panel per bay. This instructs the factory where to mount each distribution panel when the bay is populated with different types of distribution panels.
- 3) Order distribution fuses, fuseholders, circuit breakers, and load lugs as required per “Distribution Devices and Lug Selection” on page 31.

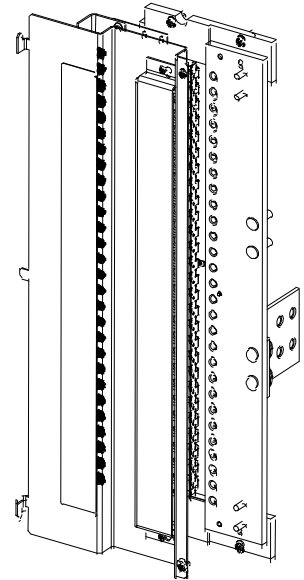

582140600 List 26: Optional Internal Ground/Return Bar, 6-Panel Bay (Full Bay Length)

Features

- ◆ Provides two (2) full bay length internal ground/return bars (one per side).
- ◆ See “Load Distribution Connections” starting on page 44 for load termination specifications.
- ◆ Includes two (2) input lug landing plate assemblies (one per side).
- ◆ Can be configured for top or bottom feed.

Restrictions

For use in List 01 and List 03.

Ordering Notes

- 1) Order as required.
- 2) Specify mounting location of included input lug landing plate assemblies: Top for top-feed or bottom for bottom feed.
- 3) List 26 internal ground/return bars are rated for 1200 A. List 48 is available to increase that capacity to 2400 A and provide additional cable landing points. Each bay can accommodate one (1) List 48. List 48 offers cable termination at the rear of the bay and the option of a bonding strap. Mounting location (top or bottom) of List 48 will be opposite that specified for the input lug landing plate assemblies of List 26.
- 4) Order load lugs as required per “Distribution Devices and Lug Selection” on page 31.

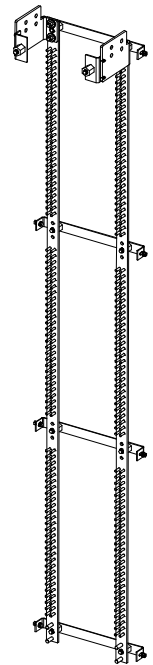

582140600 List 27: Optional Internal Ground/Return Bar, 6-Panel Bay (Panel Length)

Features

- ◆ Replaces a distribution panel on the left and right side with a panel length internal ground/return bar.
- ◆ Consists of two (2) ground/return bar assemblies and two (2) blank cover panels.
- ◆ For installation in top feed or bottom feed arrangements. When used in top feed arrangements, ground bar assemblies are installed in top most left and right distribution panel mounting positions (appropriate blank cover panels are also installed in these positions). When used in bottom feed arrangements, ground bar assemblies are installed in bottom most left and right distribution panel mounting positions (appropriate blank cover panels are also installed in these positions).
- ◆ See “Load Distribution Connections” starting on page 44 for load termination specifications.

Restrictions

For use in List 01 and List 03.

Ordering Notes

- 1) Order as required. Order one (1) List 27 for a fully configured bay.
- 2) Specify top feed or bottom feed to instruct the factory to mount the internal ground/return bars at the top or bottom of the bay.
- 3) Order load lugs as required per “Distribution Devices and Lug Selection” on page 31.

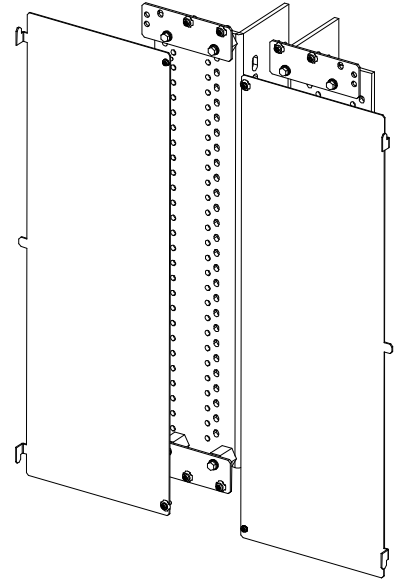

582140600 List 28: Blank Distributional Panel Cover, 6-Panel Bay

Features

- ◆ Covers an unused distribution panel position.

Restrictions

For use in List 01 and List 03.

Ordering Notes

- 1) Order one (1) List 28 for each position in a List 01 or List 03 bay that is NOT populated with a distribution panel.

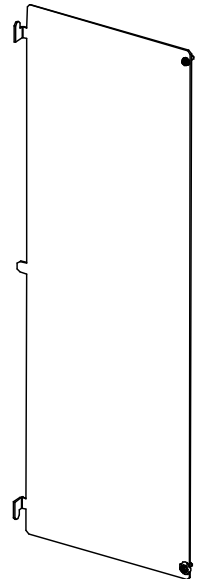

582140600 List 30: Distribution Panel Paralleling Bar, 6-Panel Bay

Features

- ◆ Parallels two distribution panels mounted one above the other.
- ◆ Each List 30 includes two (2) paralleling bars (one per side).

Restrictions

For use in Lists 01 and 03.

Ordering Notes

- 1) Order as required.

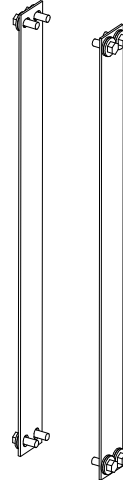

582140600 List 31: Distribution Panel Paralleling Bar, 8-Panel Bay

Features

- ◆ Parallels two distribution panels mounted one above the other.
- ◆ Each List 31 includes two (2) paralleling bars (one per side).

Restrictions

For use in Lists 07 and 09.

Ordering Notes

- 1) Order as required.

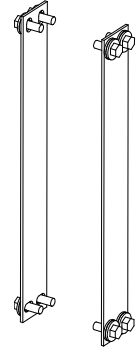

582140600 List 39: Optional Internal Ground/Return Bar Paralleling Kit, 8-Panel Bay (Panel Length)

Features

- ◆ Parallels the List 17 internal ground/return bars.
- ◆ Each List 39 consists of two (2) paralleling bars for two sides.

Restrictions

For use with List 17 only.

Ordering Notes

- 1) Order one (1) List 39 if two (2) List 17 ordered for the same bay.

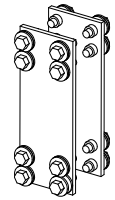

582140600 List 43: Bay Input Feed and Shunt Assembly (4 Cables, 25 mV Shunts)

- ◆ Provides landing points for four (4) input leads (on each side).
- ◆ Provides an 800 A, 25 mV shunt (one per side).
- ◆ Can be rotated for top or bottom feed configurations.
- ◆ See “DC Input Connections” on page 54 for input termination specifications.

Restrictions

For use in Lists 01, 03, 07, and 09.

Ordering Notes

- 1) Order as required. Each List 43 provides input terminations and shunts for both sides.
For top and bottom feed 2-load applications, order one (1) List 43 and specify top or bottom feed.
For top and bottom feed multi-load applications, order one (1) List 43 for each Side A / Side B load and specify top or bottom feed.
- 2) Order input lugs as required per “DC Input Connections” starting on page 54.

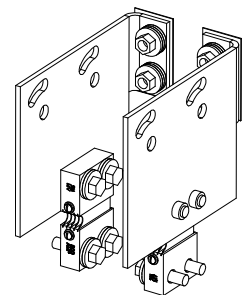

582140600 List 48: 2400 A Ground/Return Input Assembly, with Optional Bonding Strap

Features

- ◆ Provides additional landing points for ground/return input leads (both sides) to the optional List 16 or List 26 internal ground/return bar.
- ◆ Increases ground/return bar rating from 1200 A to 2400 A.
- ◆ Each List 48 provides two (2) input lug landing plate assemblies (one per side).
- ◆ Included is an optional bonding strap for connecting both ground/return bars together for any current requirement up to 2400 A.

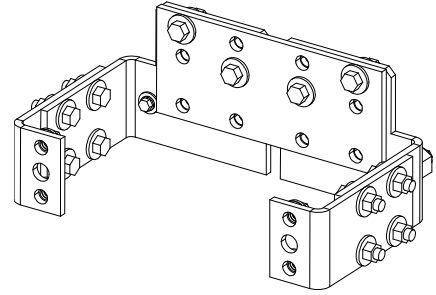

Restrictions

For use with List 16 and List 26 internal ground/return bars only.

Ordering Notes

- 1) List 16 and 26 internal return bars are rated for 1200 A. List 48 is available to increase that capacity to 2400 A and provide additional cable landing points. Each bay can accommodate one (1) List 48. List 48 offers cable termination at the rear of the bay and the option of a bonding strap. Mounting location (top or bottom) of List 48 will be opposite that specified for the input lug landing plate assemblies of List 16 or List 26.
- 2) See “DC Input Connections” on page 54 for input termination specifications.

582140600 List 51: Dressing Bar, 16” Deep Bays

Features

- ◆ Provides adjustable grooming bar to allow customer to dress output load cables along the sides of the bay.

Restrictions

For use in Lists 01 and 07.

Ordering Notes

- 1) Order dressing bars as required.
- 2) Maximum of six (6) dressing bars to be ordered for a six (6) panel bay (List 01).
- 3) Maximum of eight (8) dressing bars to be ordered for an eight (8) panel bay (List 07).

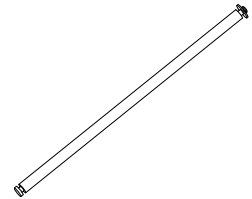

582140600 List 52: Dressing Bar, 24” Deep Bays

Features

- ◆ Provides adjustable grooming bar to allow customer to dress output load cables along the sides of the bay.

Restrictions

For use in Lists 03 and 09.

Ordering Notes

- 1) Order dressing bars as required.
- 2) Maximum of six (6) dressing bars to be ordered for a six (6) panel bay (List 03).
- 3) Maximum of eight (8) dressing bars to be ordered for an eight (8) panel bay (List 09).

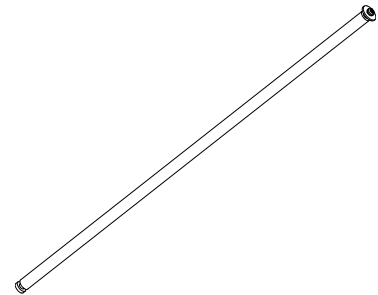

582140600 List 53: Load Distribution Cable Management Kit

Features

- ◆ Provides twelve (12) cable separators (P/N 541543) plus cable ties as a ‘Method to Manage Wiring’.

Restrictions

Not for use with List 51 or List 52.

Ordering Notes

- 1) Order one (1) kit per bay as required.

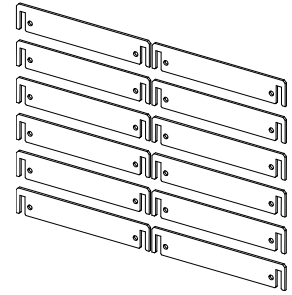

582140600 List 54: Top Cover, 16” Deep

Features

- ◆ Provides a top cover for a 16” deep bay.

Restrictions

For use with List 01 and 07.

Ordering Notes

- 1) Order List 54 as required.

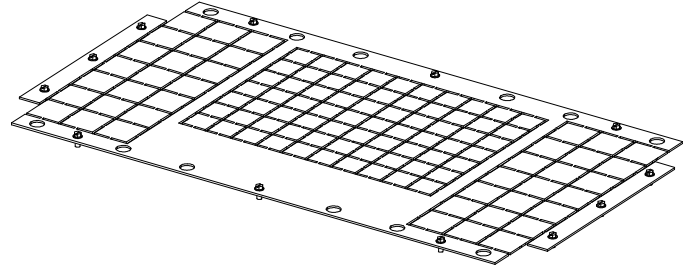

582140600 List 55: Top Cover, 24” Deep

Features

- ◆ Provides a top cover for a 24” deep bay.

Restrictions

For use with List 03 and 09.

Ordering Notes

- 1) Order List 55 as required.

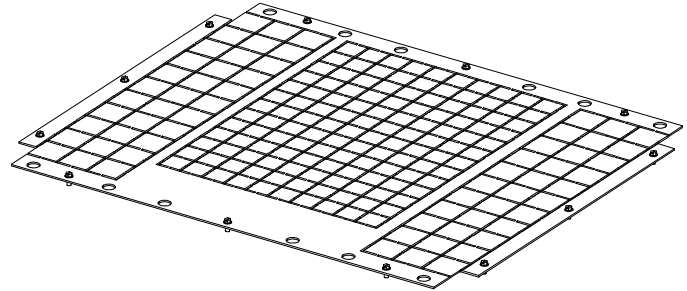

582140600 List 67: Pre-Installed Load Lug-Mounting Hardware

Features

- ◆ Provides all required 1/4” flat washers, 1/4” lock washers and 1/4-20 hex nuts for connecting customer-furnished lugs to all load distribution positions in a bay.
- ◆ If internal full-length ground/return bars (List 16 or 26) is ordered, List 67 will also include all required 1/4” lug-mounting hardware for all load return positions.
- ◆ Hardware is pre-installed on lug-landing studs.

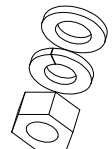

Restrictions

Does **not** provide *input* lug hardware.

Does **not** provide lug hardware for *panel length* ground/return bars (List 17 and List 27).

Ordering Notes

- 1) Order one (1) List 67 to provide pre-installed hardware on all load distribution lug positions and all full-length ground/return bar lug positions present in the bay you are ordering.

ACCESSORY DESCRIPTIONS

Load Lug Hardware Kits, P/N 547682 and 547683

Features

- ◆ These kits provide hardware for connecting customer-furnished load and load return (internal full-length ground bar only) lugs.
 - Part No. 547682 kit provides (35) each of 1/4" flat washers, 1/4" lock washers and 1/4-20 hex nuts.
 - Part No. 547683 kit provides (60) each of 1/4" flat washers, 1/4" lock washers and 1/4-20 hex nuts.
- ◆ All hardware is shipped loose in bags.

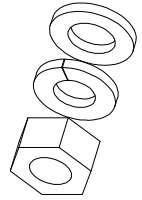

Restrictions

Does **not** provide *input* lug hardware.

Does **not** provide lug hardware for *panel length* ground/return bars (List 17 and List 27).

Ordering Notes

- 1) Order as required. Table 1 shows the quantity required for each assembly.

For <i>Each</i> of the Following List Numbers Ordered	Order This Kit Quantity	
	Kit P/N 547682	Kit P/N 547683
10	0	N/A
15	1	N/A
15A	1	N/A
16	8	N/A
20	N/A	0
25	N/A	1
25A	N/A	1
26	N/A	6

Table 1

Side by Side Distribution Panel Paralleling Bar, P/N 563497

Features

- ◆ Parallels two distribution panels mounted side by side.

Restrictions

For use with List 10, 15, 15A, 20, 25, and 25A.

Ordering Notes

- 1) Order as required.

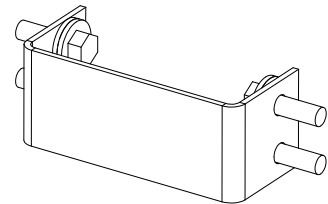

Distribution Device Numbering Scheme Reversing Kit, P/N 565436 and 565437

Features

- ◆ Provides a circuit card assembly which is to be installed in all left-hand side (as viewed from the front) advanced distribution panels installed in the bay.
The default bay advanced panel distribution device numbering scheme for system shipped prior to 12/15/2018 is shown in Figure 2.
After installing this kit, the default bay advanced panel distribution device numbering scheme will be as shown in Figure 2A.

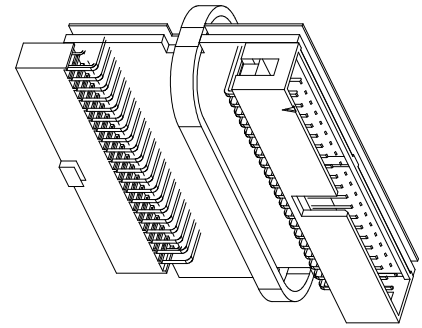

Restrictions

For use with List 15A and 25A.
For use with system shipped prior to 12/15/2018.

Ordering Notes

- 1) For systems shipped prior to 12/15/2018, order one (1) kit for each left-hand side (as viewed from the front) advance distribution panels installed in the bay.
P/N 565436 is to be used with List 25A distribution panels (6-panel bay).
P/N 565437 is to be used with List 15A distribution panels (8-panel bay).
- 2) For each List 25A that is shipped loose, order one (1) kit P/N 565436.
- 3) For each List 15A that is shipped loose, order one (1) kit P/N 565437.

BEFORE Default Bay Advanced Panel Distribution Device Numbering Scheme

Distribution Device #1	Distribution Device #28
Panel 5	Panel 6
Distribution Device #28	Distribution Device #1
Distribution Device #1	Distribution Device #28
Panel 3	Panel 4
Distribution Device #28	Distribution Device #1
Distribution Device #1	Distribution Device #28
Panel 1	Panel 2
Distribution Device #28	Distribution Device #1

6-Panel Bay

Distribution Device #1	Distribution Device #16
Panel 7	Panel 8
Distribution Device #16	Distribution Device #1
Distribution Device #1	Distribution Device #16
Panel 5	Panel 6
Distribution Device #16	Distribution Device #1
Distribution Device #1	Distribution Device #16
Panel 3	Panel 4
Distribution Device #16	Distribution Device #1
Distribution Device #1	Distribution Device #16
Panel 1	Panel 2
Distribution Device #16	Distribution Device #1

8-Panel Bay

Figure 2

AFTER Default Bay Advanced Panel Distribution Device Numbering Scheme

Distribution Device #28	Distribution Device #28
Panel 5	Panel 6
Distribution Device #1	Distribution Device #1
Distribution Device #28	Distribution Device #28
Panel 3	Panel 4
Distribution Device #1	Distribution Device #1
Distribution Device #28	Distribution Device #28
Panel 1	Panel 2
Distribution Device #1	Distribution Device #1

6-Panel Bay

Distribution Device #16	Distribution Device #16
Panel 7	Panel 8
Distribution Device #1	Distribution Device #1
Distribution Device #16	Distribution Device #16
Panel 5	Panel 6
Distribution Device #1	Distribution Device #1
Distribution Device #16	Distribution Device #16
Panel 3	Panel 4
Distribution Device #1	Distribution Device #1
Distribution Device #16	Distribution Device #16
Panel 1	Panel 2
Distribution Device #1	Distribution Device #1

8-Panel Bay

Figure 2A

Lug Adaptor Kits

P/Ns 556377 and 556378

Features

- ◆ These kits allow for load connections to the List 15, List 15A, List 16, List 25, List 25A, and List 26 panels at right angle to the standard connection and also allows for use of up to 4/0 AWG wire. The lug adapters are designed for use with 2-hole lugs with 3/8" clearance holes on 1" centers. The lug adapters permit installation of cables back to back.
- ◆ Part No. 556377 provides one (1) busbar P/N 555918, six (6) 1/4" flat washers P/N 214110100, six (6) 1/4" split lock washers P/N 215111100, and six (6) 1/4-20 hex nuts P/N 228557100.
- ◆ Part No. 556378 provides one (1) busbar P/N 555919, six (6) 1/4" flat washers P/N 214110100, six (6) 1/4" split lock washers P/N 215111100, and six (6) 1/4-20 hex nuts P/N 228557100.

Restrictions

For use with List 15, List 15A, List 16, List 25, List 25A, and List 26.
For use with three-pole circuit breaker or 3-pole ground/return only.

Ordering Notes

- 1) Order as required. Refer to Table 2 for adapter kit part numbers. Refer to Table 6 for available lugs.

Application for Right Angle Adaptors	Left Side (viewed from rear)	Right Side (viewed from rear)
Top Feed Application	P/N 556378	P/N 556377
Bottom Feed Application	P/N 556377	P/N 556378

Table 2

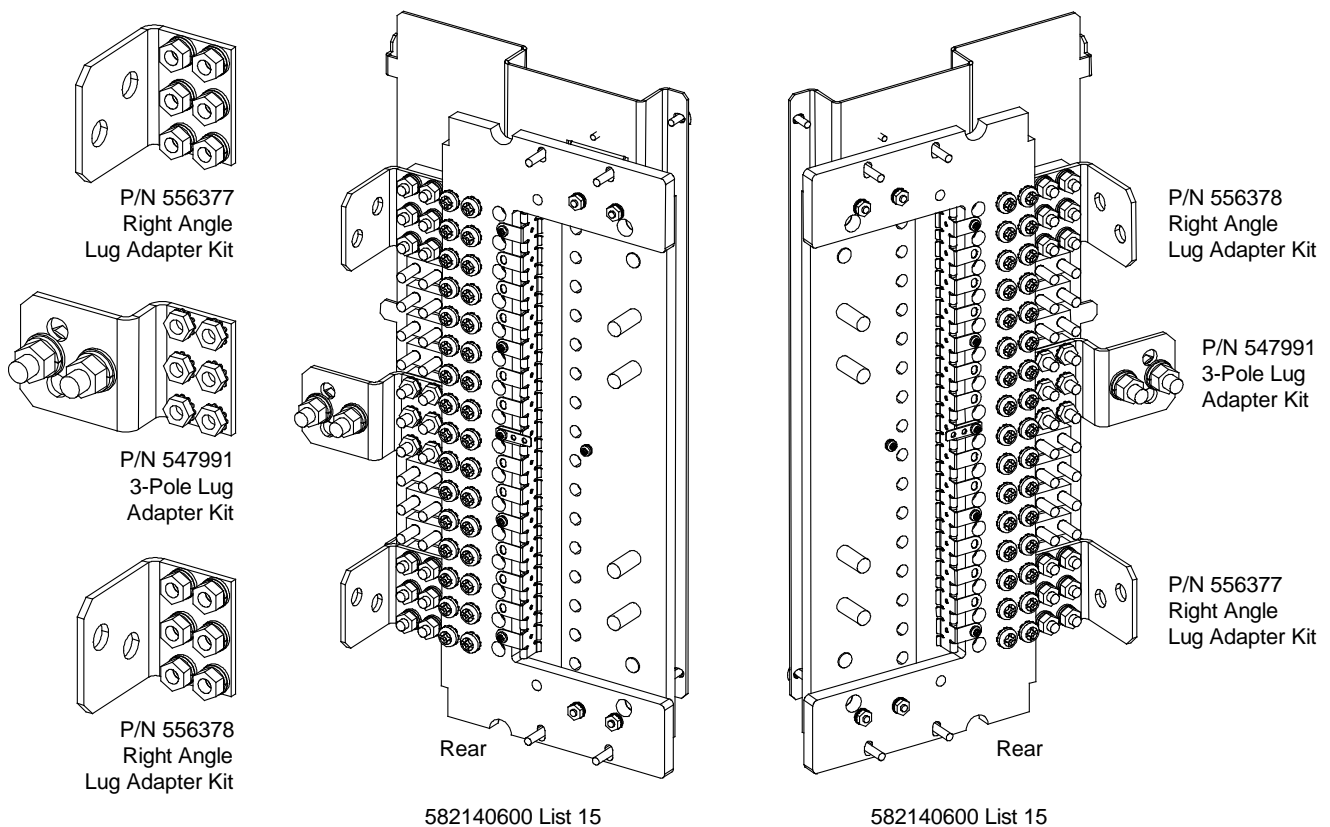

Figure 3

Vertiv™ NetSure™ DC Power Distribution System

System Application Guide

P/Ns 564906 and 564907

Features

- ◆ These kits allow for load connections to the List 15, List 15A, List 16, List 25, List 25A, and List 26 panels at right angle to the standard connection and also allows for use of up to 4/0 AWG wire. The lug adapters are designed for use with 2-hole lugs with 3/8" clearance holes on 1" centers. The lug adapters permit installation of cables back to back.
- ◆ Part No. 564906 provides one (1) busbar P/N 564905, four (4) 1/4" flat washers P/N 214110100, four (4) 1/4" split lock washers P/N 215111100, and four (4) 1/4-20 hex nuts P/N 228557100.
- ◆ Part No. 564907 provides one (1) busbar P/N 564908, four (4) 1/4" flat washers P/N 214110100, four (4) 1/4" split lock washers P/N 215111100, and four (4) 1/4-20 hex nuts P/N 228557100.

Restrictions

For use with List 15, List 15A, List 16, List 25, List 25A, and List 26.

For use with two-pole circuit breaker or 2-pole ground/return only.

Ordering Notes

- 1) Order as required. Refer to Table 3 for adapter kit part numbers. Refer to Table 6 for available lugs.

Application for Right Angle Adaptors	Left Side (viewed from rear)	Right Side (viewed from rear)
Top Feed Application	P/N 564907	P/N 564906
Bottom Feed Application	P/N 564906	P/N 564907

Table 3

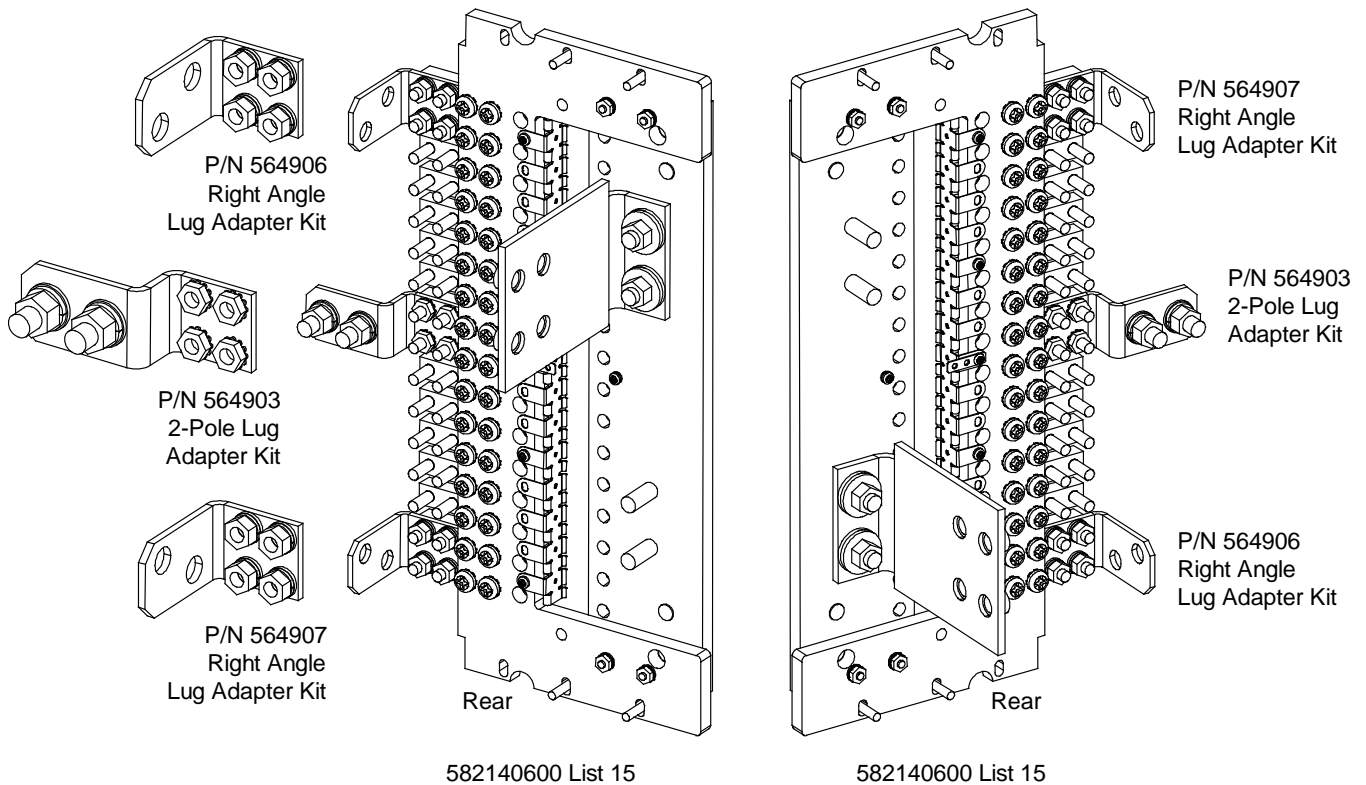
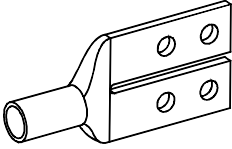
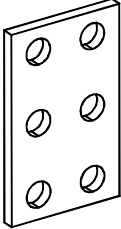
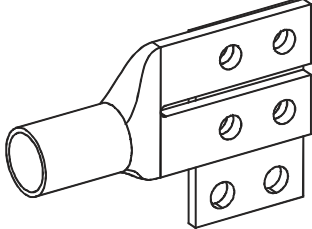
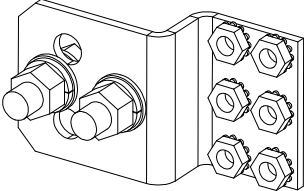
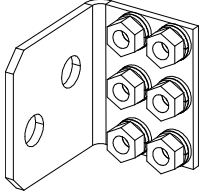
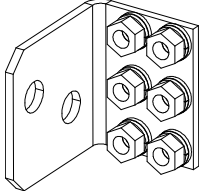
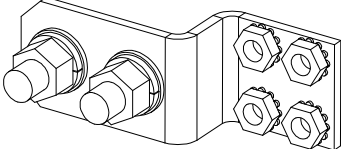
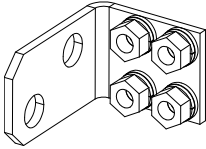
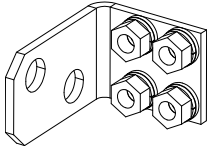
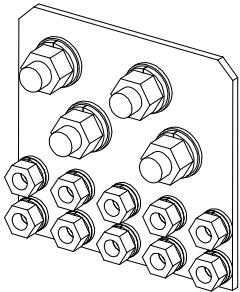

Figure 4

Special Lugs and Adapters

Special Lugs and Adapters Referenced in Table 13		
 Special Crimp Lug (See Table 13 for Part Numbers)	 Special Adapter P/N 545346	 Special Crimp Lug and Adapter
 3-Pole Lug Adapter Kit, P/N 547991	 Right Angle Lug Adapter Kit, P/N 556377	 Right Angle Lug Adapter Kit, P/N 556378
 2-Pole Lug Adapter Kit, P/N 564903	 Right Angle Lug Adapter Kit, P/N 564906	 Right Angle Lug Adapter Kit, P/N 564907
 3-Pole Breaker Lug Adapter Kit, P/N 558718		

External Return/Ground Bar Assemblies

Ordering Notes

- 1) Order return/ground bar assembly(s) as required per Table 4. One (1) per bay provides landing positions for each fuse position in the bay assuming that cables are terminated back to back. If individual termination is required, order two (2) per bay.
- 2) Order bonding strap kit as required per Table 4. Bonding strap kit includes one strap (P/N 351532900) plus hardware.
- 3) Order return lugs as required.

Two hole lug, 1/4" bolt clearance holes, 5/8" centers: See Table 5.

Two hole lug, 3/8" bolt clearance holes, 1" centers: See Table 6.

Return/Ground Bar Assemblies	
8 Panel Bay Return/Ground Bar Assembly	436110200
6 Panel Bay Return/Ground Bar Assembly	436110300
Bonding Strap Kit	534834

Table 4

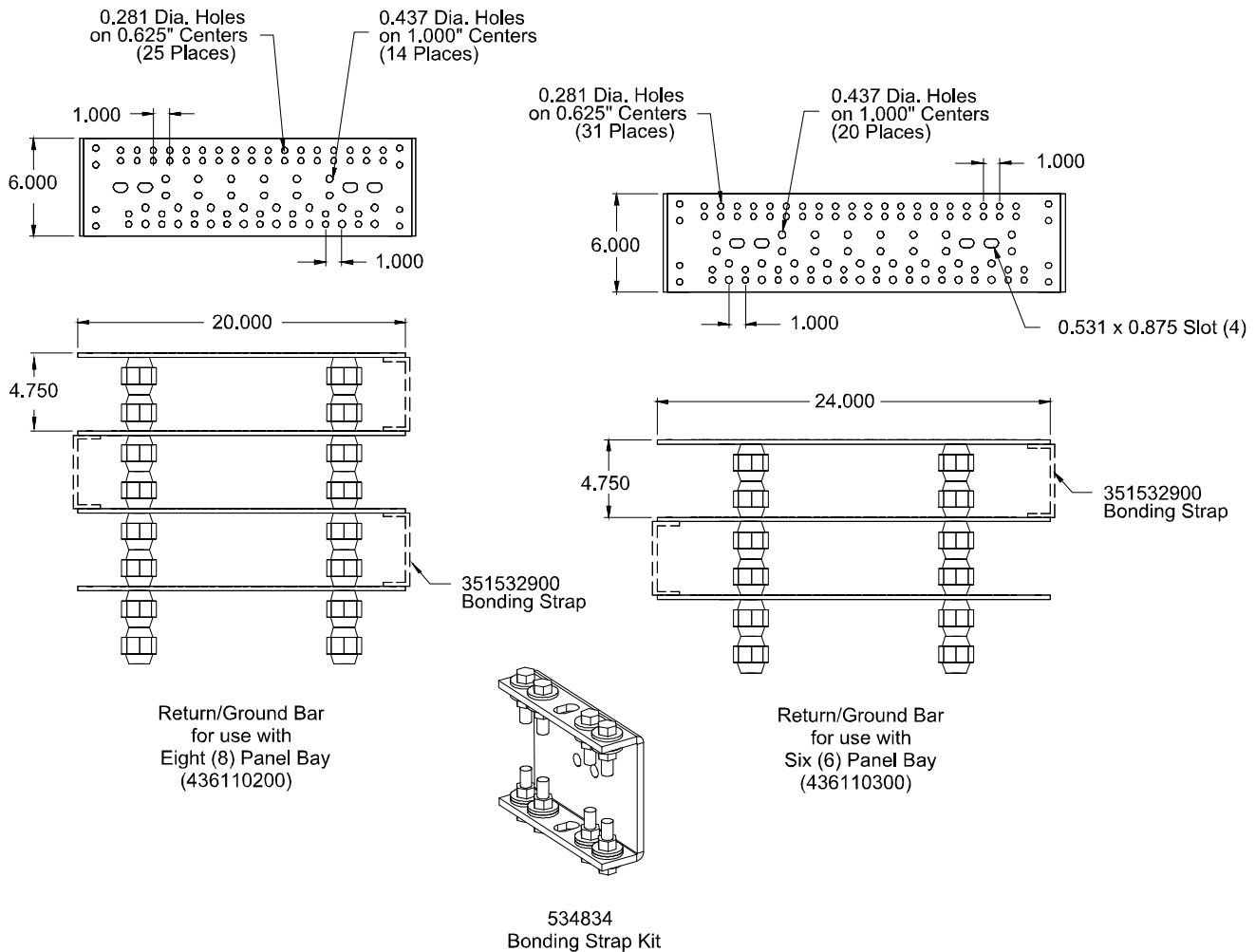
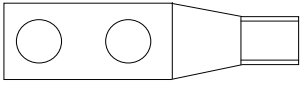

Figure 5

Standard Crimp Lug Tables

Lead Size	Part Number
14-10 AWG	245342300
8 AWG	245390200
6 AWG	245346700
4 AWG	245346800
2 AWG	245346900



Lugs should be crimped per lug manufacturer's specifications.

Table 5
Crimp Lug
Two-Hole, 1/4" Bolt Clearance Hole, 5/8" Centers

Lead Size	Part Number
6 AWG	245349900
4 AWG	245350000
2 AWG	245348200
1/0 AWG	245347100
2/0 AWG	245347200
3/0 AWG	245347300
4/0 AWG	245347400
250 kcmil	245347500
300 kcmil	245347600
350 kcmil	245347700
400 kcmil	245347800
500 kcmil	245347900
600 kcmil	245348000
750 kcmil	245348100

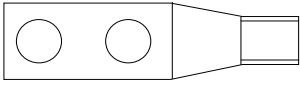

Lugs should be crimped per lug manufacturer's specifications.

Table 6
Crimp Lug
Two-Hole, 3/8" Bolt Clearance Hole, 1" Centers

Seismic Anchor Kit, P/N 545387

Features

- ◆ Provides four (4) relay rack seismic mounting anchors, P/N 216821200.

Restrictions

For use with List 01, List 03, List 07, List 09.

Ordering Notes

- 1) Order seismic anchor kit P/N 545387 as required.

Transient Voltage Surge Suppressor (TVSS) Device

Features

- ◆ When properly grounded, the device(s) suppresses transient voltages that are above 60 VDC.
- ◆ Contains an indicator which lights when circuit has activated to suppress voltages.
- ◆ Plugs into distribution device mounting positions of a List 15, List 15A, List 25, and List 25A distribution panel.

Restrictions

To be used with distribution panels List 15, List 15A, List 25, and List 25A only.

All unparallelled distribution panels require a TVSS device, only one (1) TVSS device required per parallelled groups of distribution panels.

Unless otherwise specified, install the TVSS device in the mounting position closest to the distribution panel's input busbar.

Wire to be sized so that the maximum wire resistance is less than 0.550 milliohms.

Caution: The TVSS device occupies two mounting positions. Leave an additional empty mounting position between the TVSS device and any overcurrent protective device.

Ordering Notes

- 1) Order kit P/N 520401 (includes TVSS device P/N 122201 plus lug mounting hardware) as required. Customer to supply grounding lead(s) with lugs to connect from TVSS device(s) into customer's grounding network.

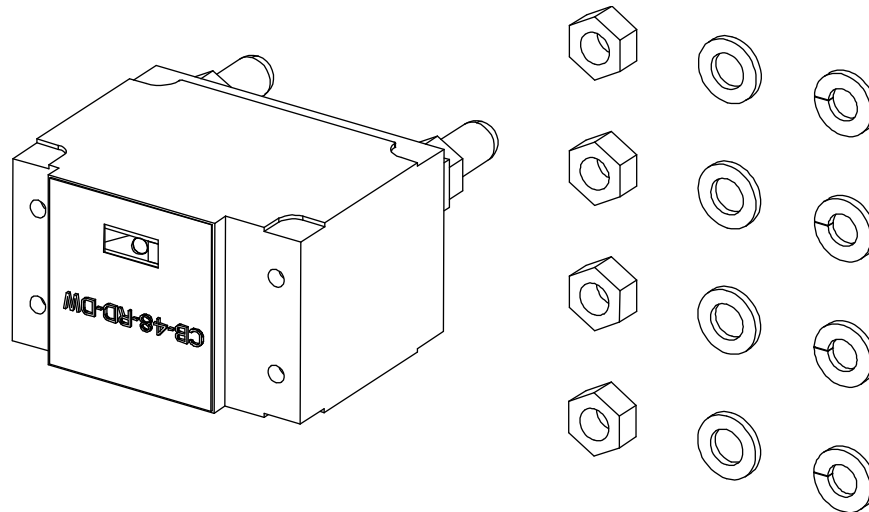

Figure 6

Distribution Devices and Lug Selection

List 10 and List 20 Fuse Panels

Features

- ◆ List 10 fuse panel has twelve (12) fuse positions.
List 20 fuse panel has twenty (20) fuse positions.
Each fuse panel can be populated with TLS/TPS fuseblocks (requires one [1] fuse position), TPL-B fuseblocks (requires two [2] fuse positions), or a combination of TLS/TPS and TPL-B fuseblocks.
- ◆ List 10 fuse panel is factory equipped with twelve (12) TLS/TPS fuseblocks P/N 248817100.
List 20 fuse panel is factory equipped with twenty (20) TLS/TPS fuseblocks P/N 248817100.
For fuse panels **factory** configured in a bay, TLS/TPS fuseblocks can be replaced by the factory with TPL-B fuseblocks as ordered. See Ordering Notes below.

Restrictions

The fuses and fuseblocks specified in this section are for use in List 10 and List 20 fuse panels.

Maximum fuse size is 70 A.

Load should not exceed 80% of device rating.

Distribution panel capacity is 640 A maximum continuous.

TLS/TPS Fuseblock: Maximum lug width is 0.750".
Maximum wire size is 2 AWG.

TPL-B Fuseblock: Maximum lug width is 1.8".
Maximum wire size is 2/0 AWG.

Ordering Notes

- 1) If TPL-B fuseblocks are required, order as required per P/N 516241. For fuse panels **factory** configured in a bay, the factory replaces two (2) P/N 248817100 fuseblocks in a fuse panel with one (1) TPL-B fuseblock P/N 516241 ordered. For fuse panels shipped separately, the TLS/TPS fuseblocks are factory installed and if TPL-B fuseblocks are required they will have to be installed in the field. See also Table 7 and Table 9.
- 2) For each TLS/TPS fuseblock ordered, also order one (1) P/N 248610301 alarm fuse and one (1) P/N 248898700 safety fuse cover. The alarm fuse and safety fuse cover is provided with a TPL-B fuseblock.
- 3) Order TLS/TPS and/or TPL-B fuses as required per Table 7 and Table 9.
- 4) See Table 8 and Table 10 for recommended load lugs.
- 5) See Table 16 and Table 17 for recommended load distribution wire sizes.

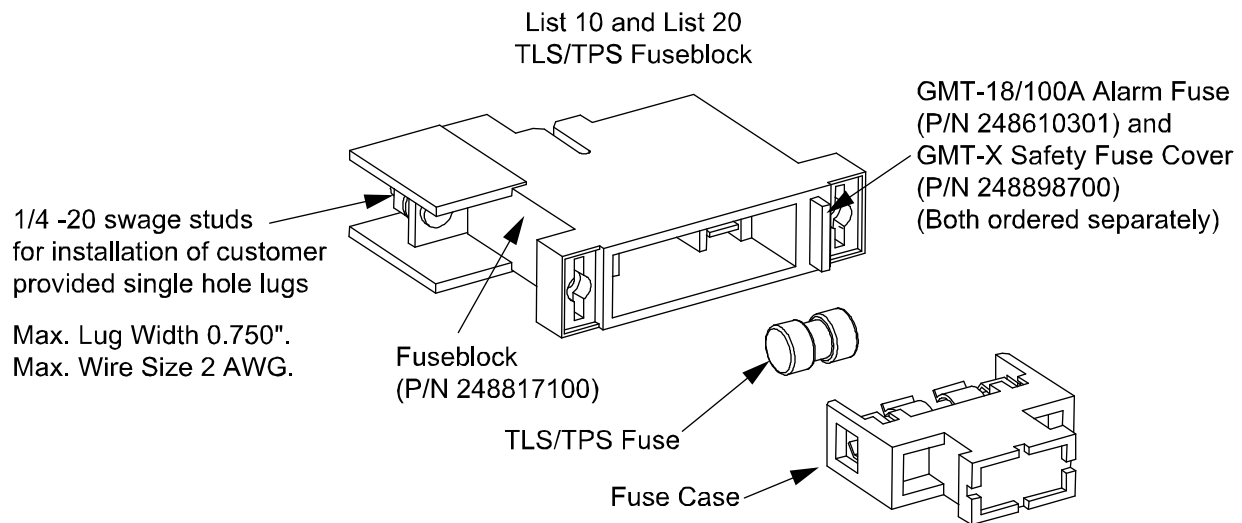

Figure 7

TLS/TPS Fuses and Fuseblocks for Use in List 10 and List 20				
Ampere Rating	P/N	Bussmann P/N	Littelfuse P/N	Lugs for Fuseblock P/N 248817100
3	248230900	TPS-3	TLS003	See Table 8
5	248231000	TPS-5	TLS005	
6	248231200	TPS-6	TLS006	
10	248231500	TPS-10	TLS010	
15	248231800	TPS-15	TLS015	
20	248232100	TPS-20	TLS020	
25	248232400	TPS-25	TLS025	
30	248232700	TPS-30	TLS030	
40	248233300	TPS-40	TLS040	
50	248233900	TPS-50	TLS050	
60	248234200	TPS-60	TLS060	
70	248234500	TPS-70	TLS070	
Each fuse requires (1) fuseblock P/N 248817100. See "Ordering Notes" in this section. For each fuseblock ordered, also order... (1) P/N 248610301 alarm fuse (GMT-18/100A), and (1) P/N 248898700 safety fuse cover (GMT-X).				
See Table 16 for recommended load distribution wire sizes.				

Table 7
TLS/TPS Fuses and Fuseblocks
for Use in List 10 and List 20 Fuse Panel

Lugs for Use with Fuseblock P/N 248817100 Used in List 10 and List 20 (single hole, 1/4" bolt clearance hole)	
Lead Size (AWG)	P/N
8	245350400
6	245350600
4	245350700
2	245350800

Note: Cables larger than 2 AWG require an H-TAP connection.

Table 8
Lugs for Use with Fuseblock P/N 248817100
Used in List 10 and List 20 Fuse Panel

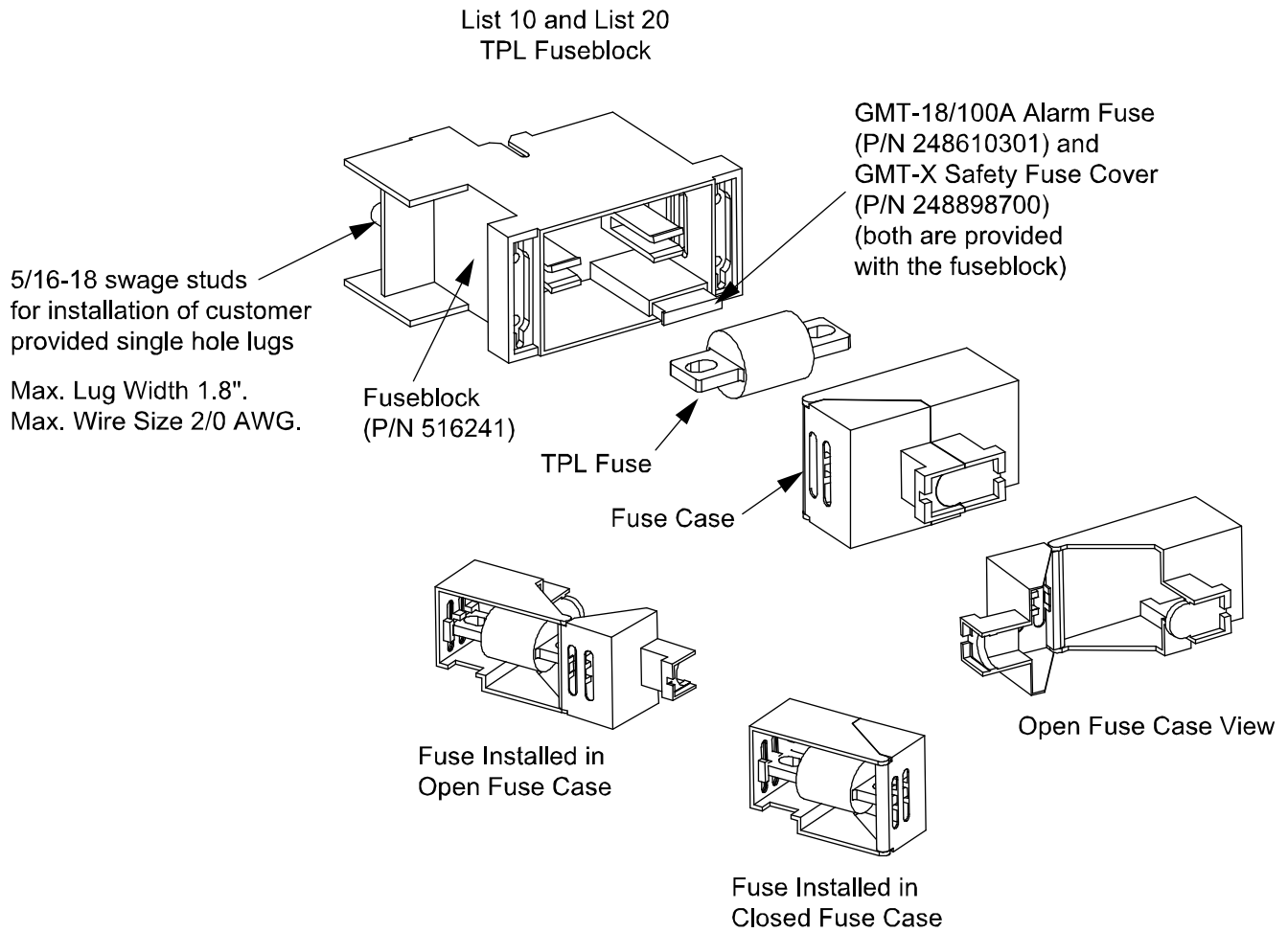

Figure 8

TPL-B Fuses and Fuseblock for Use in List 10 and List 20			
Ampere Rating	Required Distribution Bus Mounting Positions	P/N	Lugs for Fuseblock P/N 516241
70	2	248251500	See Table 10
80	2	248252000	
100	2	248252600	
150	2	248253300	
200	2	248254000	
225	2	248254500	
250	2	248255000	
Each fuse requires (1) fuseblock P/N 516241. See "Ordering Notes" in this section. Fuseblock P/N 516241 also includes... (1) P/N 248610301 alarm fuse (GMT-18/100A), and (1) P/N 248898700 safety fuse cover (GMT-X). See Table 17 for recommended load distribution wire sizes.			

Table 9
TPL-B Fuses and Fuseblock
for Use in List 10 and List 20 Fuse Panel

Lugs for Use with Fuseblock P/N 516241 Used in List 10 and List 20 (single hole, 5/16" bolt clearance hole)	
Lead Size (AWG)	P/N
6	245351380
4	245351390
2	245351400
1	120224

Note: Cables larger than 2/0 AWG require an H-TAP connection.

Table 10
Lugs for Use with Fuseblock P/N 516241
Used in List 10 and List 20 Fuse Panel

List 15, List 15A, List 25, and List 25A Fuse/Circuit Breaker Panels

Features

- ◆ List 15 and List 15A fuse/circuit breaker panel have sixteen (16) bullet nose circuit breaker and/or TLS/TPS fuse (with bullet nose fuseholder) positions.
- ◆ List 25 and List 25A fuse/circuit breaker panel have twenty-eight (28) bullet nose circuit breaker and/or TLS/TPS fuse (with bullet nose fuseholder) positions.
- ◆ Each circuit breaker plugs into one, two or three distribution device mounting position(s).
- ◆ A single fuseblock provides for installation of a 3 to 70 ampere Bussmann TPS-type or a 3 to 125 ampere Littelfuse TLS-type fuse. The fuseblock plugs into a single distribution device mounting position. The fuseblock provides a GMT-A alarm type fuse, which operates open to provide an alarm indication if the distribution fuse opens.

Restrictions

The circuit breakers, fuses, and fuseblocks specified in this section are for use in List 15, List 15A, List 25, and List 25A fuse/circuit breaker panels.

Load should not exceed 80% of device rating.

Distribution panel capacity is 640 A maximum continuous.

Maximum lug width is 0.610".

Maximum wire size is 2 AWG.

Ordering Notes

- 1) Order circuit breakers per Table 11.
- 2) Order fuses per Table 12.

For each fuse ordered, also order one (1) P/N 117201 bullet nose fuseblock.

Note: Fuseblock P/N 117201 also includes...
(1) Alarm Fuse P/N 248610301 and
(1) Safety Fuse Cover P/N 248898700.

- 3) See Table 13 for recommended load lugs.
- 4) See Table 16 for recommended load distribution wire sizes.

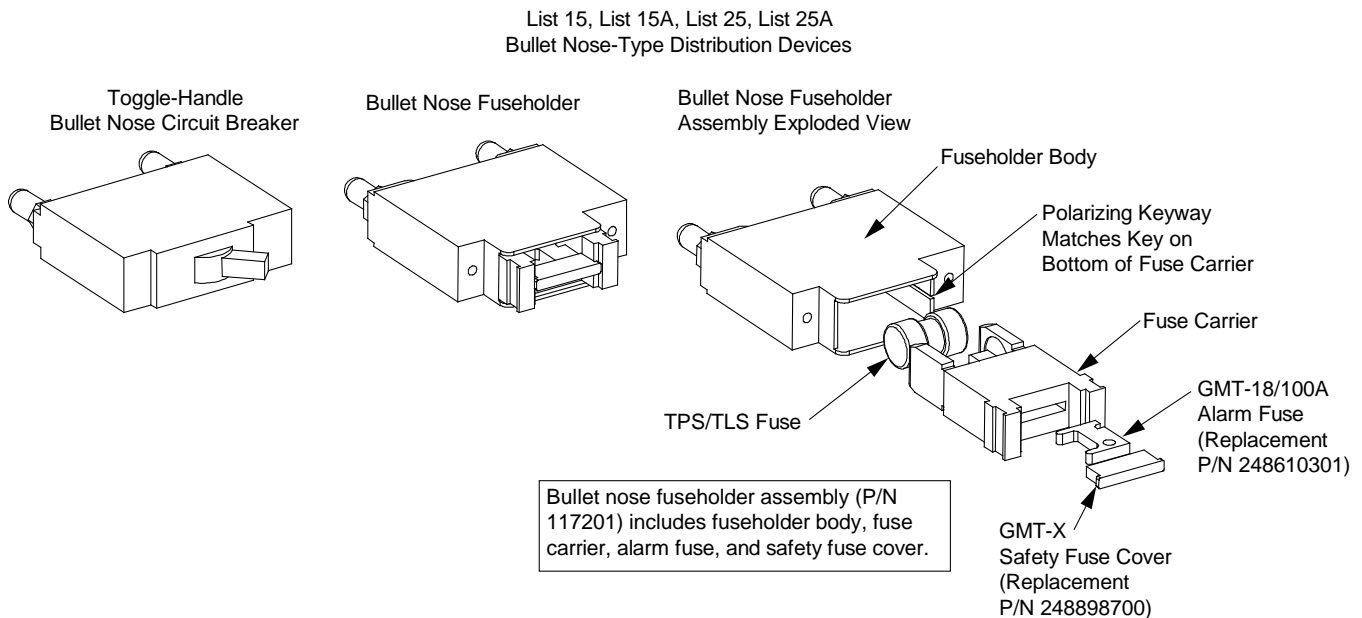

Figure 9

Toggle-Handle Bullet Nose Type Circuit Breakers for Use in List 15, List 15A, List 25, List 25A				
Ampere Rating	Number of Poles (and mounting positions required)	P/N		Lugs
		Electrical Trip ¹ (White Handle)	Electrical/ Mechanical Trip ² (Black Handle)	
1	1	102272	101596	Up to 2 AWG lead sizes, use lugs in Table 13 (1/4" clearance holes on 5/8" centers. From 1/0 AWG to 350 kcmil lead sizes, use lugs in Table 13 (Special Crimp Lug).
3	1	102273	101597	
5	1	102274	101598	
10	1	102275	101599	
15	1	102276	101600	
20	1	102277	101601	
25	1	102278	101602	
30	1	102279	101603	
35	1	102280	101604	
40	1	102281	101605	
45	1	121998	121997	
50	1	102282	101606	
60	1	102283	101607	
70	1	102284	101608	
75	1	102285	101609	
80	1	121996	121995	
90	1	138887	138888	
100	1	102286	101610	
125	1	--	150607	
125	2	516991	516838	Use lugs in Table 13 (Special Crimp Lug).
150	2	516993	516839	
175	2	144883	144884	
200	2	121831	121832	
225	3	144885	144886	Use lugs in Table 13 (Special Crimp Lug) plus special lug adapter P/N 545346 or lug adapters listed in Table 13.
250	3	121835	121836	
300	3	149075	149076	

See Table 16 for recommended load distribution wire sizes.

Circuit Breaker Alarm Operation:

¹ Provides an alarm during an electrical trip condition only.

² Provides an alarm during an electrical or manual trip condition.

Table 11
Toggle-Handle Bullet Nose Type Circuit Breakers
for Use in List 15, List 15A, List 25, List 25A Fuse/Circuit Breaker Panels

Bullet Nose-Type Fuseblocks and TLS/TPS Fuses for Use in List 15, List 15A, List 25, List 25A				
Ampere Rating	P/N	Bussmann P/N	Littelfuse P/N	Lugs
3	248230900	TPS-3	TLS003	Up to 2 AWG lead sizes, use lugs in Table 13 (1/4" clearance holes on 5/8" centers. From 1/0 AWG to 350 kcmil lead sizes, use lugs in Table 13 (Special Crimp Lug).
5	248231000	TPS-5	TLS005	
6	248231200	TPS-6	TLS006	
10	248231500	TPS-10	TLS010	
15	248231800	TPS-15	TLS015	
20	248232100	TPS-20	TLS020	
25	248232400	TPS-25	TLS025	
30	248232700	TPS-30	TLS030	
40	248233300	TPS-40	TLS040	
50	248233900	TPS-50	TLS050	
60	248234200	TPS-60	TLS060	
70	248234500	TPS-70	TLS070	
80 (note 1)	118413	--	TLS080	
90 (note 1)	118414	--	TLS090	
100 (note 1)	118415	--	TLS100	
125 (note 1)	139052	--	TLS125	
For each fuse ordered, also order a bullet nose fuseblock P/N 117201. Fuseblock P/N 117201 also includes... (1) P/N 248610301 alarm fuse (GMT-18/100A), and (1) P/N 248898700 safety fuse cover (GMT-X).				
See Table 16 for recommended load distribution wire sizes.				
Note 1: Cannot be used on List 10 and List 20.				

Table 12
Bullet Nose-Type Fuseblocks and TLS/TPS Fuses
for Use in List 15, List 15A, List 25, List 25A Fuse/Circuit Breaker Panels

Lugs for Use with List 15, List 15A, List 25, List 25A (two hole, 1/4" bolt clearance hole on 5/8" centers)	
Lead Size (AWG)	P/N
8	245390200
6	245346700
4	245346800
2	245346900
1/0	245393500 (special crimp lug)
2/0	245393600 (special crimp lug)
3/0	245393700 (special crimp lug)
4/0	245393800 (special crimp lug)
250 kcmil	514872 (special crimp lug)
350 kcmil	514873 (special crimp lug)
3-Pole Device Special Adapter	545346

Lugs for Use with P/Ns 547991, 556377, 556378, 564903, 564906, and 564907 Lug Adapter Kits (two hole, 3/8" bolt clearance holes on 1" centers)	
Wire Size	Part Number
6 AWG	245349900
4 AWG	245350000
2 AWG	245348200
1/0 AWG	245347100
2/0 AWG	245347200
3/0 AWG	245347300
4/0 AWG	245347400
250 kcmil	245347500
300 kcmil	245347600
350 kcmil	245347700
400 kcmil	245347800
500 kcmil	245347900
600 kcmil	245348000
750 kcmil	245348100

For one-pole circuit breaker, cables larger than 2 AWG require an H-TAP connection.
For two-pole circuit breaker, use **either** special crimp lugs per table **or** lug adapter kit P/N 564903, 564906, or 564907 with 2-hole lugs having 3/8" clearance holes on 1" centers.
For three-pole circuit breaker and 3-pole ground/return, use **either** special crimp lugs per table with adapter P/N 545346, **or** lug adapter kit P/N 547991, 556377, or 556378 with 2-hole lugs having 3/8" clearance holes on 1" centers.
For fuseblock (P/N 117201), cables larger than 2 AWG require H-tap. Special crimp lugs listed above can be used but will use two positions of the distribution panel.
See also "Lug Adaptor Kits" on page 25.

Table 13
Lugs for Use with List 15, List 15A, List 25, List 25A Fuse/Circuit Breaker Panels

User Replaceable Alarm, Reference, and Control Fuses

Fuses Located on Auxiliary Fuse Card at Top of Bay

Features

- ◆ Control and auxiliary load fuses are located on the fuseblock mounted at the top right of each bay. See Figure 10 and Figure 12.

Note also that distribution fuses also contain alarm-type fuses as detailed in the previous sections of this document.

Ordering Notes

- 1) Order replacement fuses as required per Table 14.

Function	Size (Amperes)	Type	P/N
F1, F2: Auxiliary loads, sourced from Feed A (-48V).	1-1/3A	Bussmann GMT-A	248610700
F3, F4: Auxiliary loads, sourced from Feed B (-48V).			
F5, F6: External ABS (A&B) input to Electronics			
Safety Fuse Cover		Bussmann GMT-X	248898700

Table 14
Replaceable Alarm, Reference, and Control Fuses

User Replaceable Components

Ordering Notes

- 1) Refer to Table 15.

Item	Part Number
Monitor Unit	1M832DNA
SM-DUE	ROA1190937/1
SM-DUH2	563101 (Assembly), ROA1190929/1 (Board Only)
IB2 Interface Board	SXK2300129/1 (Assembly), MA4C5U31 (Board Only)
IB5 (second Ethernet Port) Board	10146319
Auxiliary Fuse Card	547760

Table 15
User Replaceable Components

RECOMMENDED WIRE SIZES, BRANCH CIRCUIT PROTECTION, CRIMP LUGS, AND WIRING ILLUSTRATIONS

Overall Installer's Connections Illustration

Bay Overall Connections Diagram

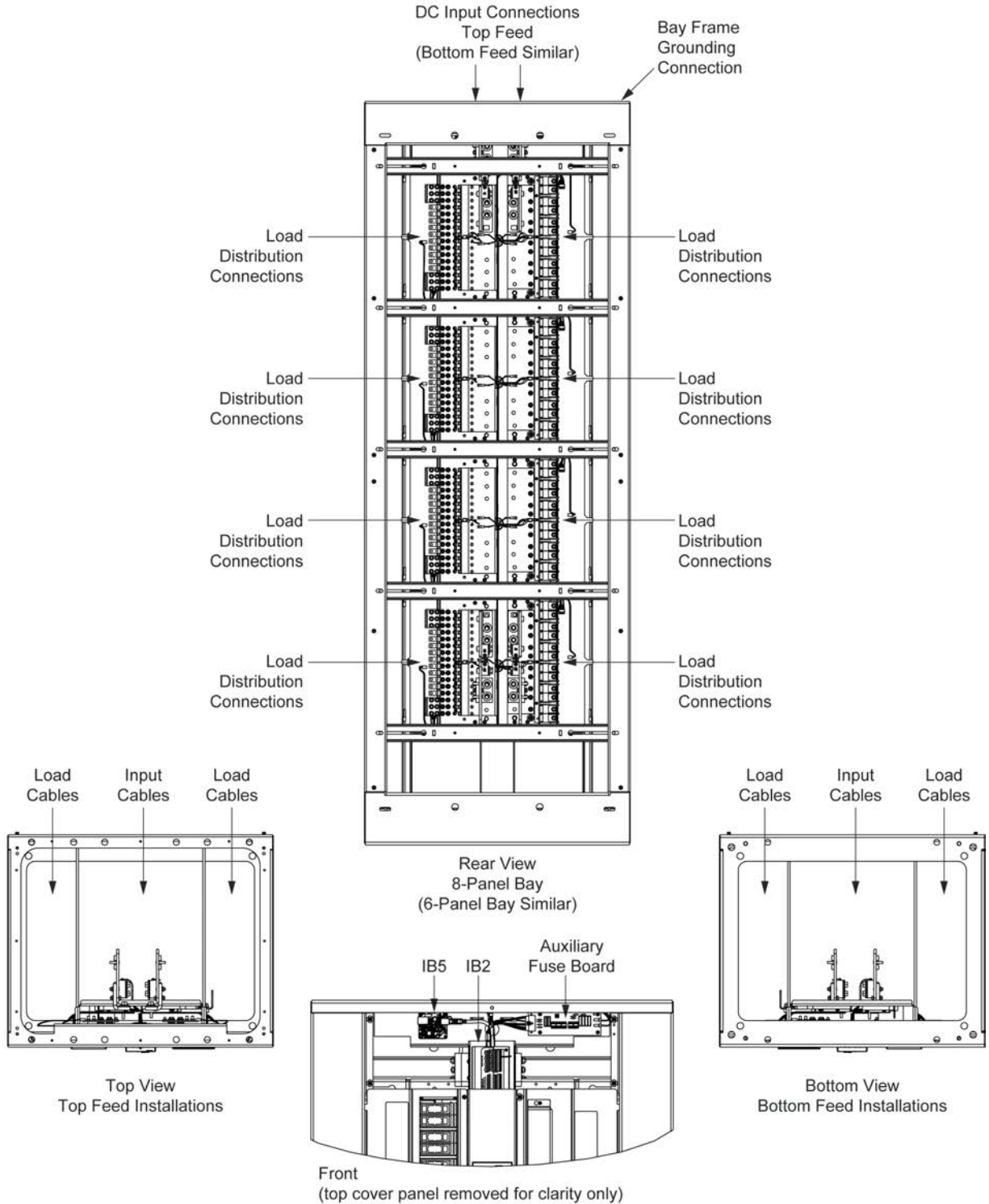

Figure 10

Bay Frame Grounding Requirements

General

For bay frame grounding requirements, refer to the current edition of the American National Standards Institute (ANSI) approved National Fire Protection Association's (NFPA) National Electrical Code (NEC), applicable local codes, and your specific site requirements.

A customer's grounding network lead can be attached to the top of each bay as shown in Figure 11. Provision is made for installing a lead with a two-hole lug that has 1/4" bolt clearance holes on 5/8" centers.

The recommended frame grounding wire size is 6 AWG. The recommended lug is P/N 245346700. All lugs for customer connections must be ordered separately. Customer needs to supply lug mounting bolts and hardware.

Bay Frame Grounding Connection

Bay Frame Grounding Connection

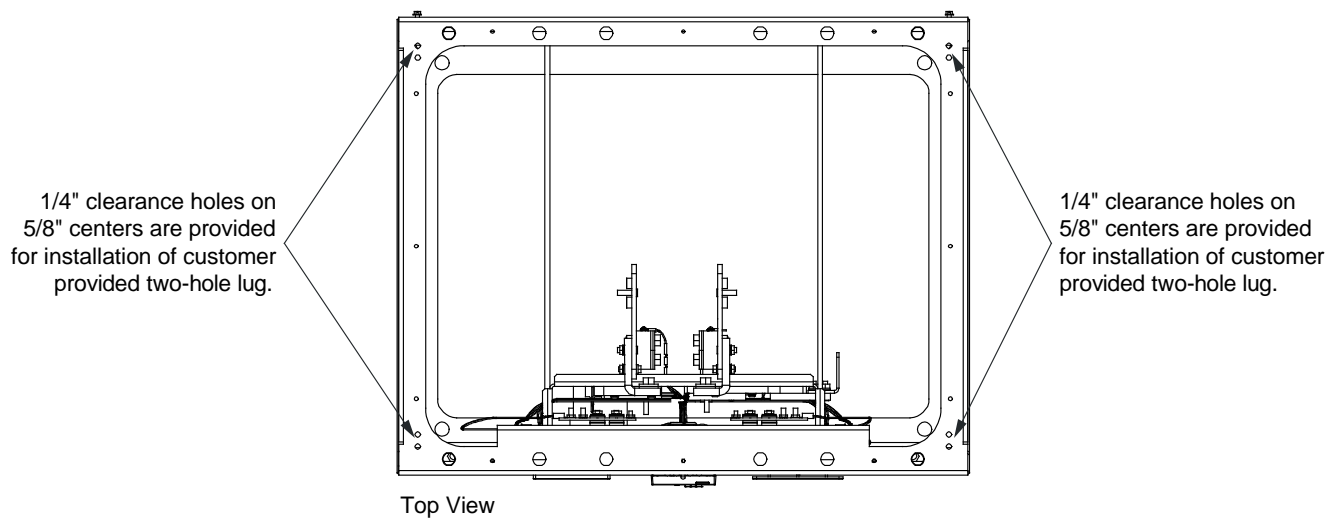

Figure 11

Auxiliary Fuse Circuit Card

An auxiliary fuse circuit card is located behind the top right panel in each bay. This circuit card provides four fuses for auxiliary equipment loads and two fuses for optional external (ABS) power to the electronics. All fuses are rated at 1-1/3A. Terminal blocks are provided on the circuit card for auxiliary load connections and external (ABS) electronics input power connections.

Terminal block wire size capacity is 14 AWG max.

Installer must make system ground/return connection(s) to side A and side B ground/return input busbars. See Figure 13.

- 1) Recommended Wire Size (Auxiliary Fuse Load and Return): 14 AWG.
- 2) Recommended Wire Size (Ground/Return Input Busbars): 14 AWG.

ABS and Aux. Supply Connections

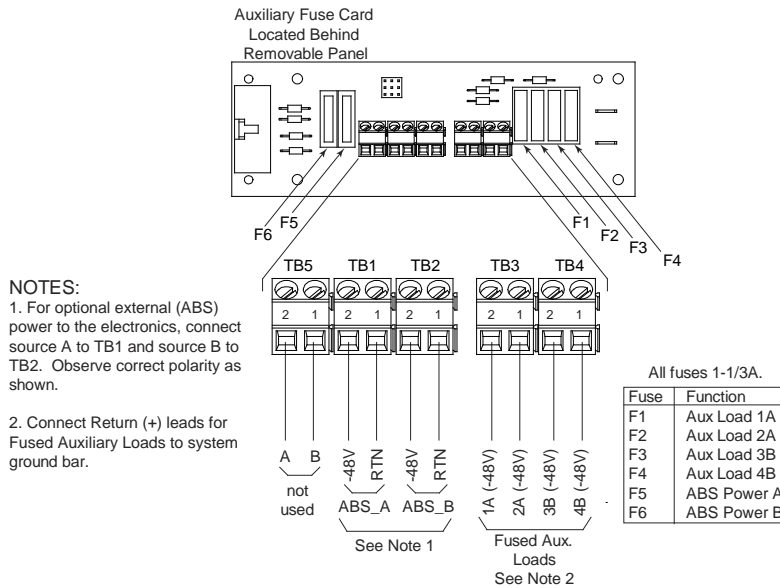

Figure 12

Ground/Return Input Connections for Auxiliary Fuse Card

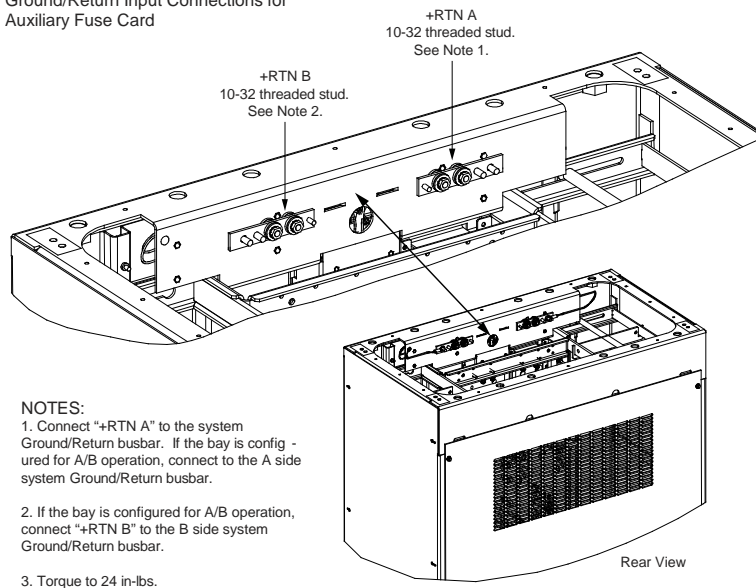

Figure 13

Monitor Unit Ethernet Connection (if required)

The monitor unit provides a Web Interface via an Ethernet connection to a TCP/IP network. This interface can be accessed locally on a computer or remotely through a network. An Ethernet port is provided on the monitor unit's top panel (see Figure 14). A second Ethernet port is provided on the IB5 board (see Figure 10 and Figure 15). The Ethernet port located on the monitor unit's top panel can ONLY be used to connect a computer directly to the monitor unit. The Ethernet port located on the IB5 board can be used to connect the monitor unit to your Local Area Network (LAN).

To Monitor Unit

An RJ-45 10BaseT jack is provided on the top panel of the monitor unit for connection to a computer for local access to the monitor unit's web pages (see Figure 14).

Note: Your system has an IB5 board, DO NOT connect your Local Area Network (LAN) to the monitor unit's top panel Ethernet port.

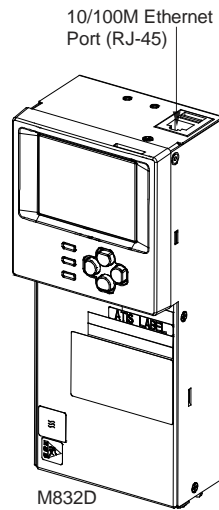

Figure 14

To IB5 Board

An RJ-45 10BaseT jack is provided on the IB5 board for connection into a customer's Local Area Network (LAN) for remote access to the monitor unit's web pages (see Figure 10 and Figure 15).

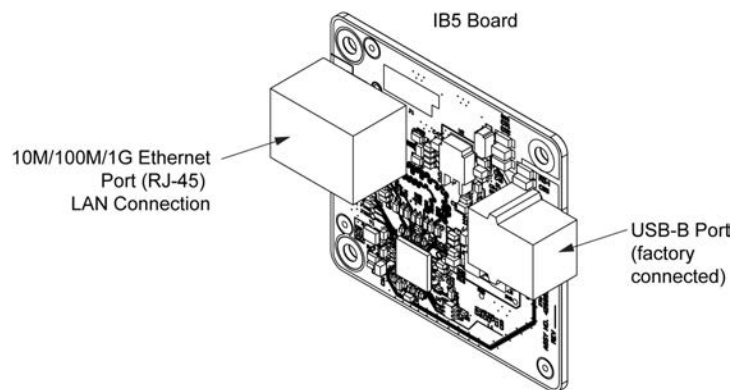

Figure 15

Load Distribution Connections

General

The rating of the distribution device determines the wire size requirements. Refer to the American National Standards Institute (ANSI) approved National Fire Protection Association's (NFPA) National Electrical Code (NEC) and applicable local codes. For wire size selection, refer to Table 16 and Table 17.

The type of distribution device determines the load lug hole size and spacing requirements. For lug selection, refer to "Distribution Devices and Lug Selection" starting on page 31. All lugs for customer connections must be ordered separately. Customer needs to supply lug mounting bolts and hardware.

Maximum size of wire to be connected to a single lug position and maximum lug width are listed under "Distribution Devices and Lug Selection" starting on page 31.

Load distribution (load side) leads terminated in the appropriate lug are connected to the 'load side' terminations provided on each distribution panel. See Figure 16.

Load distribution (return side) leads terminated in the appropriate lug are connected to the 'load return side' terminations provided on the optional internal ground/return bars or to the optional external ground/return bars. See Figure 16.

Fuse/Circuit Breaker Amperage	Recm 90 °C Wire Size ⁽¹⁾						
	14 AWG	12 AWG	10 AWG	8 AWG	6 AWG	4 AWG	2 AWG
	Loop Length (feet) ⁽²⁾						
1, 3, 5, 6, 10 A	37 ^(3,4)	58 ^(3,4)	93 ^(3,4)	--	--	--	--
15 A	24 ^(3,4)	39 ^(3,4)	62 ^(3,4)	--	--	--	--
20 A	--	29 ^(3,4)	46 ^(3,4)	74 ^(3,4)	--	--	--
25 A	--	--	37 ^(3,4)	59 ^(3,4)	94 ^(3,4)	--	--
30 A	--	--	31 ^(3,4)	49 ^(3,4)	78 ^(3,4)	--	--
35 A	--	--	--	42 ^(3,4)	67 ^(3,4)	107 ^(3,4)	--
40 A	--	--	--	37 ^(3,4)	59 ^(3,4)	94 ^(3,4)	--
45 A	--	--	--	33 ^(3,4)	52 ^(3,4)	83 ^(3,4)	--
50 A	--	--	--	29 ^(3,4)	47 ^(3,4)	75 ^(3,4)	--
60 A	--	--	--	--	39 ^(3,4)	62 ^(3,4)	99 ^(3,4)
70 A	--	--	--	--	33 ⁽³⁾	53 ^(3,4)	85 ^(3,4)
75 A	--	--	--	--	31 ⁽³⁾	50 ^(3,4)	79 ^(3,4)
80 A	--	--	--	--	--	47 ^(3,4)	74 ^(3,4)
90 A	--	--	--	--	--	41 ⁽³⁾	66 ^(3,4)
100 A	--	--	--	--	--	--	59 ^(3,4)

- ¹ Wire sizes based on recommendations of the American National Standards Institute (ANSI) approved National Fire Protection Association's (NFPA) National Electrical Code (NEC). Table 310.15 (B) (16) for copper wire at 90 °C conductor temperature. For operation in countries where the NEC is not recognized, follow applicable codes.
- ² Recommended wire sizes are sufficient to restrict voltage drop to 1.0 volt or less at listed branch current for the loop lengths shown. Loop length is the sum of the lengths of the positive and negative leads.
- ³ Wire Size / Loop Length Combination Calculated using 30 °C Ambient Operating Temperature.
- ⁴ Wire Size / Loop Length Combination Calculated using 40 °C Ambient Operating Temperature.

Table 16 (cont'd on next page)
Recommended Load Distribution Wire Sizes for
TLS/TPS Fuse and Bullet Nose-Type Circuit Breaker

Vertiv™ NetSure™ DC Power Distribution System
System Application Guide

Fuse/ Circuit Breaker Amperage	Recm 90 °C Wire Size ⁽¹⁾							
	4 AWG	2 AWG	1/0 AWG	2/0 AWG	3/0 AWG	4/0 AWG	250 kcmil	350 kcmil
	Loop Length (feet) ⁽²⁾							
90A	41 ⁽³⁾	66 ^(3,4)	105 ^(3,4)	133 ⁽⁴⁾	--	--	--	--
100A	--	59 ^(3,4)	95 ^(3,4)	119 ^(3,4)	--	--	--	--
125A	--	47 ⁽³⁾	76 ^(3,4)	95 ^(3,4)	120 ⁽⁴⁾	--	--	--
150A	--	--	63 ^(3,4)	79 ^(3,4)	100 ^(3,4)	--	--	--
175A	--	--	--	68 ^(3,4)	86 ^(3,4)	108 ^(3,4)	--	--
200A	--	--	--	--	75 ^(3,4)	95 ^(3,4)	112 ^(3,4)	--
225A	--	--	--	--	67 ⁽³⁾	84 ^(3,4)	100 ^(3,4)	--
250A	--	--	--	--	--	76 ^(3,4,7)	90 ^(3,4,7)	126 ^(3,4,7)
300A	--	--	--	--	--	--	--	105 ^(3,4,7)

- ¹ Wire sizes based on recommendations of the American National Standards Institute (ANSI) approved National Fire Protection Association's (NFPA) National Electrical Code (NEC). Table 310.15 (B) (16) for copper wire at 90 °C conductor temperature. For operation in countries where the NEC is not recognized, follow applicable codes.
- ² Recommended wire sizes are sufficient to restrict voltage drop to 1.0 volt or less at listed branch current for the loop lengths shown. Loop length is the sum of the lengths of the positive and negative leads.
- ³ Wire Size / Loop Length Combination Calculated using 30 °C Ambient Operating Temperature.
- ⁴ Wire Size / Loop Length Combination Calculated using 40 °C Ambient Operating Temperature.

Table 16 (cont'd from previous page)
Recommended Load Distribution Wire Sizes for
TLS/TPS Fuse and Bullet Nose-Type Circuit Breaker

Vertiv™ NetSure™ DC Power Distribution System
System Application Guide

Fuse/ Circuit Breaker Amperage	Recm 90 °C Wire Size ⁽¹⁾									
	6 AWG	4 AWG	2 AWG	1/0 AWG	2/0 AWG	3/0 AWG	4/0 AWG	250 kcmil	300 kcmil	350 kcmil
	Loop Length (feet) ⁽²⁾									
70 A	33 ⁽³⁾	53 ^(3, 4)	85 ^(3, 4)	135 ^(3, 4)	--	--	--	--	--	--
80 A	--	47 ^(3, 4)	74 ^(3, 4)	118 ^(3, 4)	--	--	--	--	--	--
100 A	--	--	59 ^(3, 4)	95 ^(3, 4)	119 ^(3, 4)	--	--	--	--	--
150 A	--	--	--	63 ^(3, 4)	79 ^(3, 4)	100 ^(3, 4)	--	--	--	--
200 A	--	--	--	--	--	75 ^(3, 4)	95 ^(3, 4)	112 ^(3, 4)	--	--
225 A	--	--	--	--	--	67 ⁽³⁾	84 ^(3, 4)	100 ^(3, 4)	120 ^(3, 4)	--
250 A	--	--	--	--	--	--	76 ⁽³⁾	90 ^(3, 4)	108 ^(3, 4)	126 ^(3, 4)

- ¹ Wire sizes based on recommendations of the American National Standards Institute (ANSI) approved National Fire Protection Association's (NFPA) National Electrical Code (NEC). Table 310.15 (B) (16) for copper wire at 90 °C conductor temperature. For operation in countries where the NEC is not recognized, follow applicable codes.
- ² Recommended wire sizes are sufficient to restrict voltage drop to 1.0 volt or less at listed branch current for the loop lengths shown. Loop length is the sum of the lengths of the positive and negative leads.
- ³ Wire Size / Loop Length Combination Calculated using 30 °C Ambient Operating Temperature.
- ⁴ Wire Size / Loop Length Combination Calculated using 40 °C Ambient Operating Temperature.
- ⁵ Single-hole lug, 5/16" bolt clearance hole. Lugs should be crimped per lug manufacturer's specifications.

Table 17
Recommended Load Distribution Wire Sizes for **TPL-B Fuse**

Load Distribution Connections Illustrations

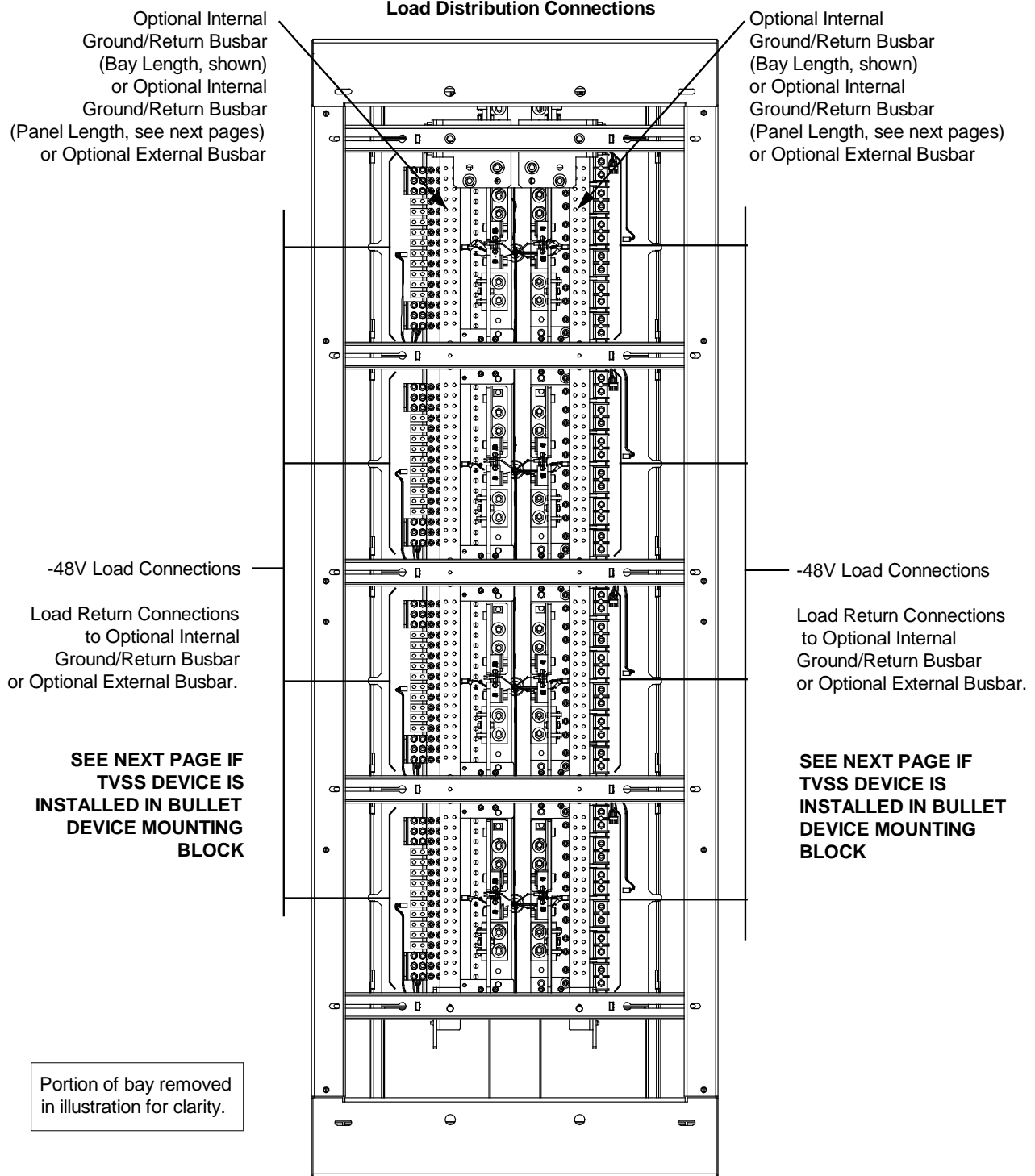

Rear View
 8-Panel Bay
 (6-Panel Bay Similar)

Figure 16 (cont'd on next page)
 Load Distribution Connections

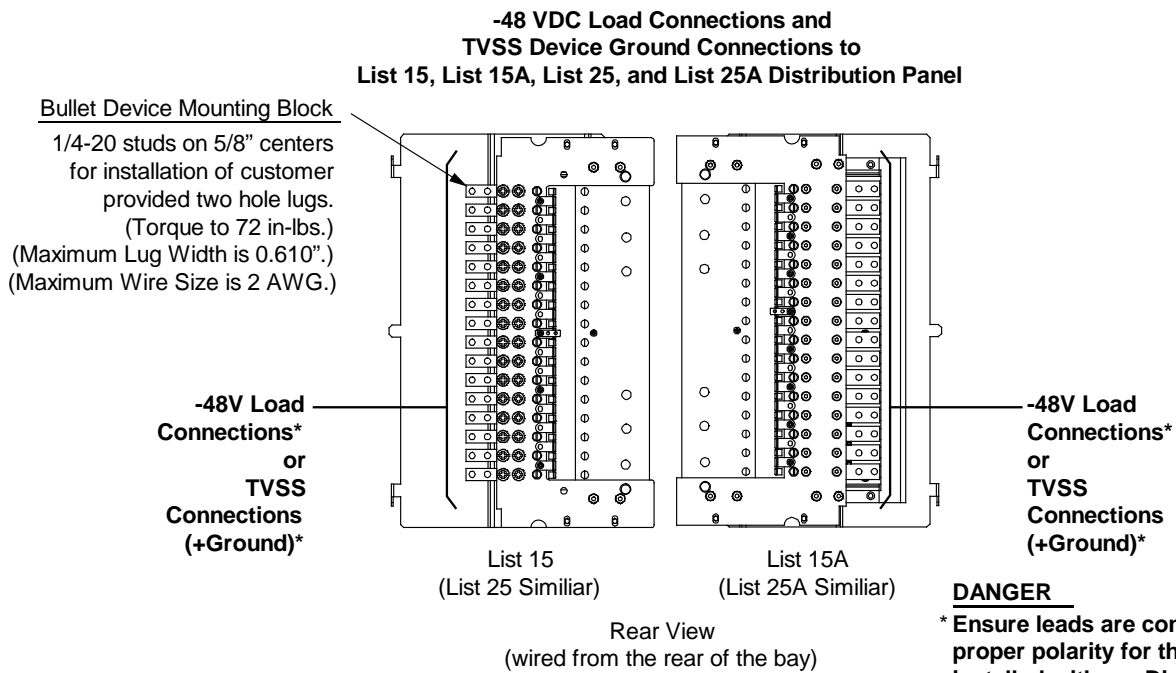
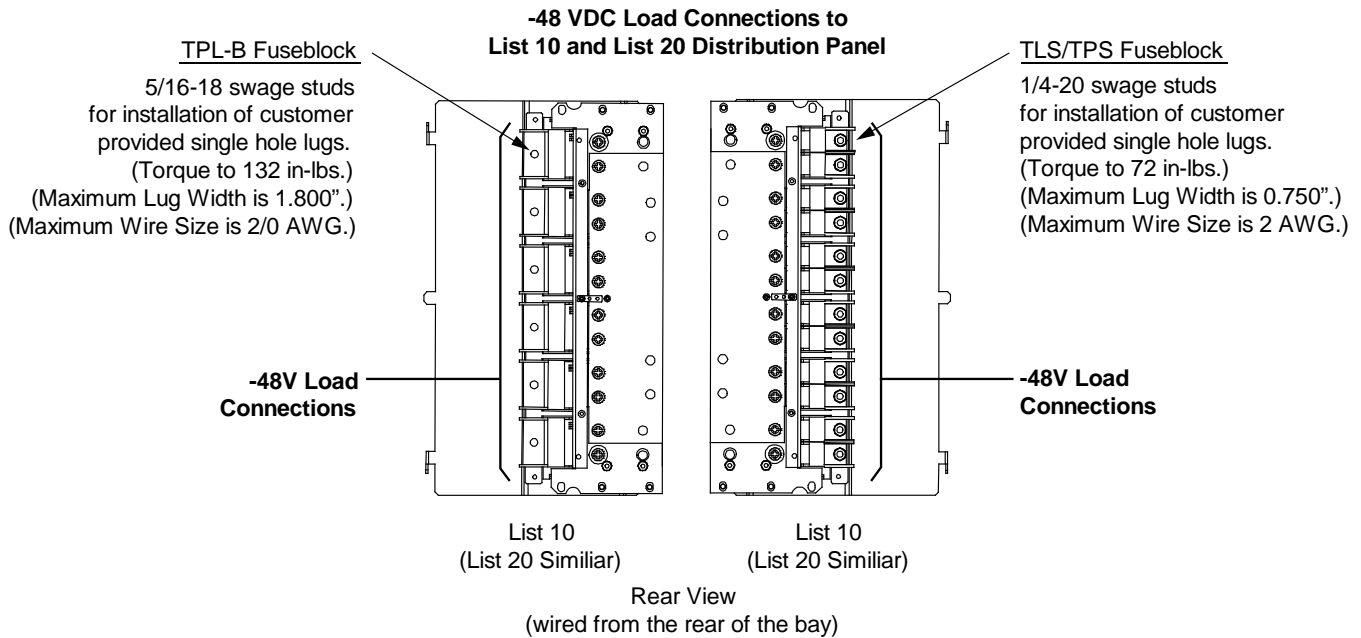

DANGER
* Ensure leads are connected to proper polarity for the device installed, either a Distribution Device (load lead connection) or a TVSS Device (ground connection).

Figure 16 (cont'd from previous page, cont'd on next page)
Load Distribution Connections

Optional Internal Ground/Return
 Busbar Connections
 (Bay Length)

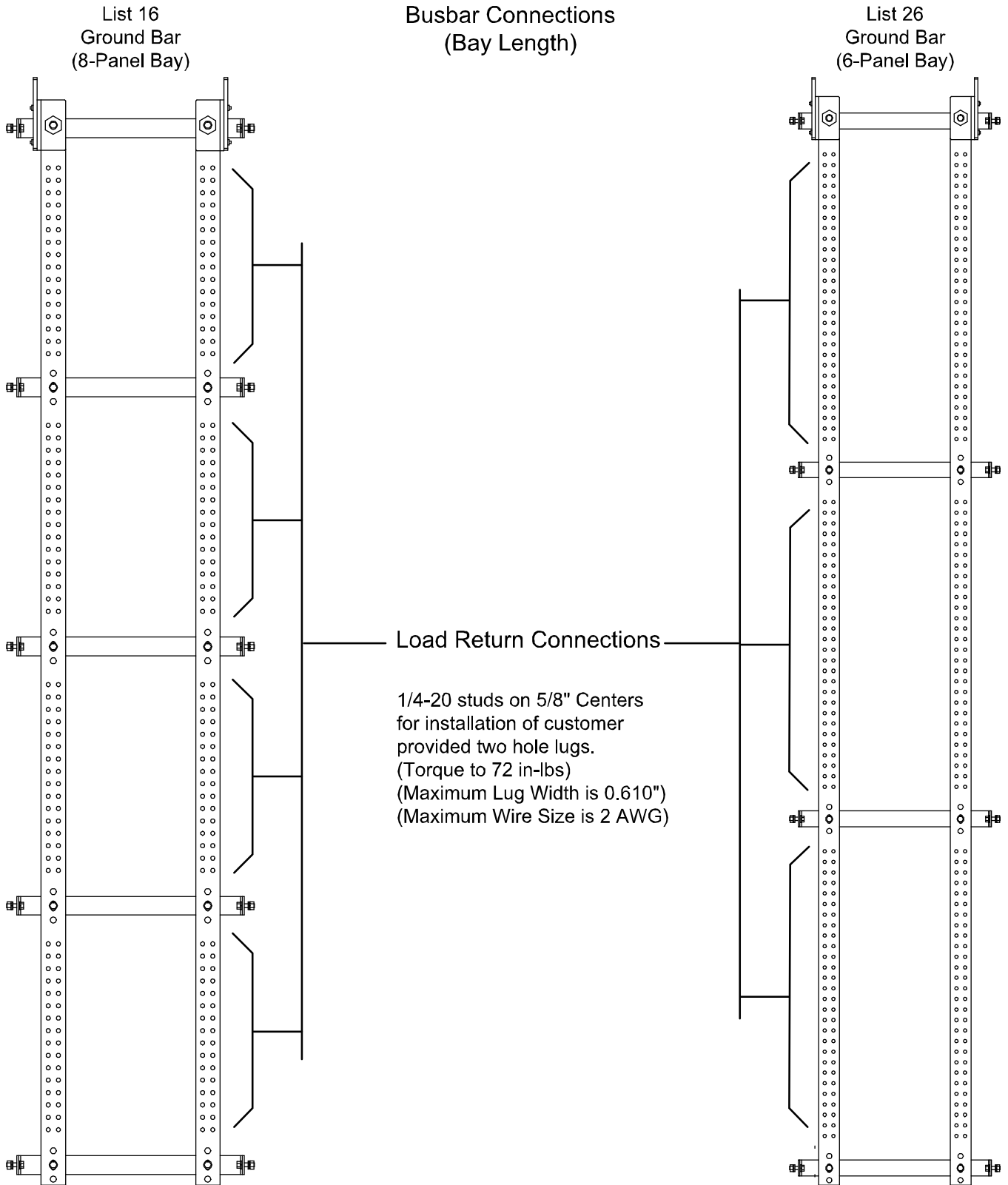

Figure 16 (cont'd from previous page, cont'd on next page)
 Load Distribution Connections

**Optional Internal
 Ground/Return Busbar
 Connections
 (Distribution Panel Length,
 Replaces a Distribution Panel)**

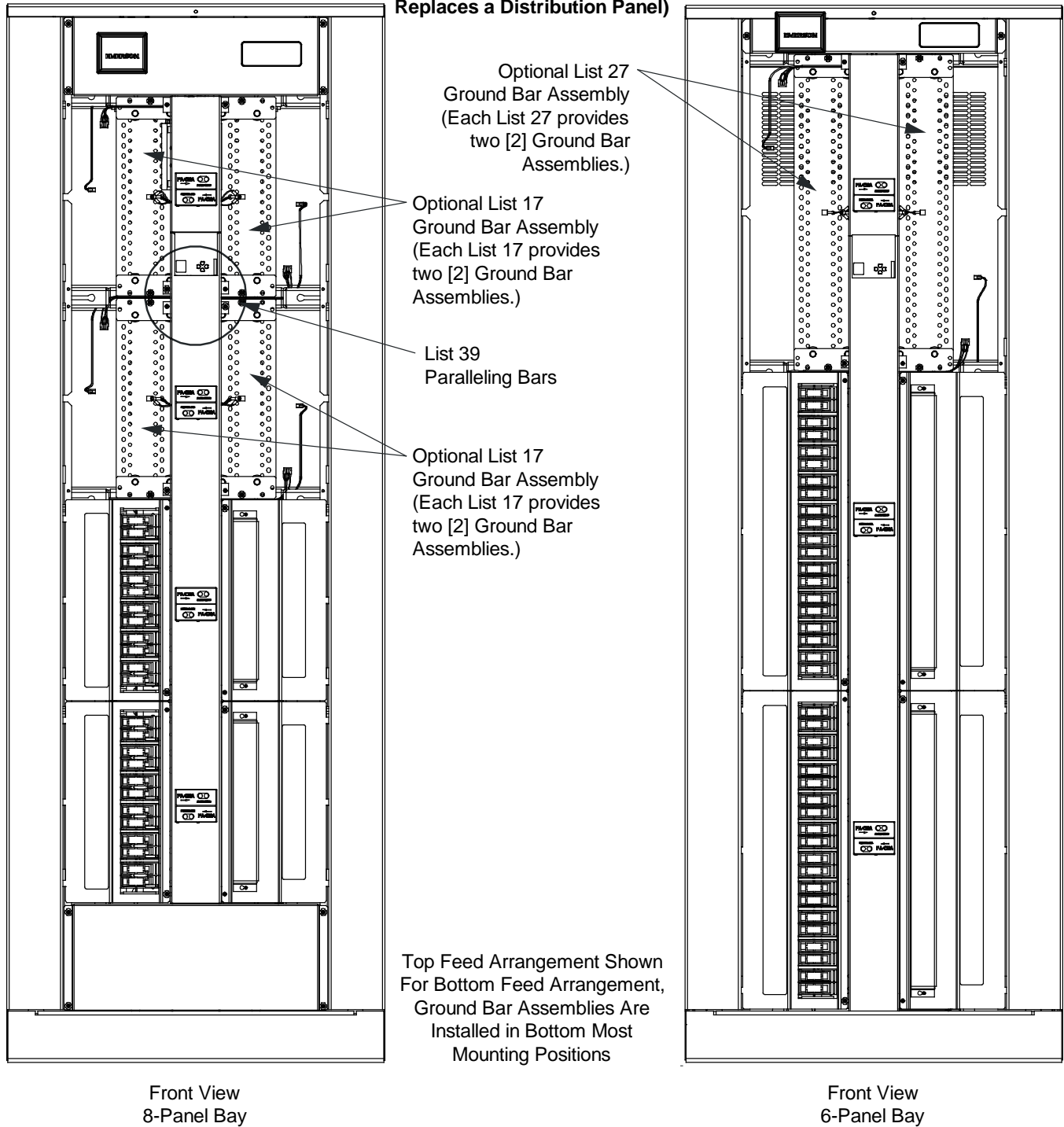
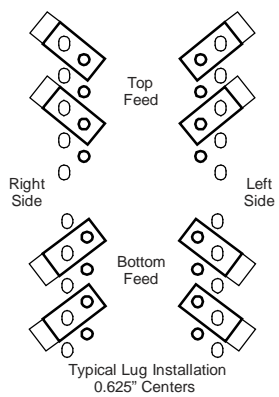
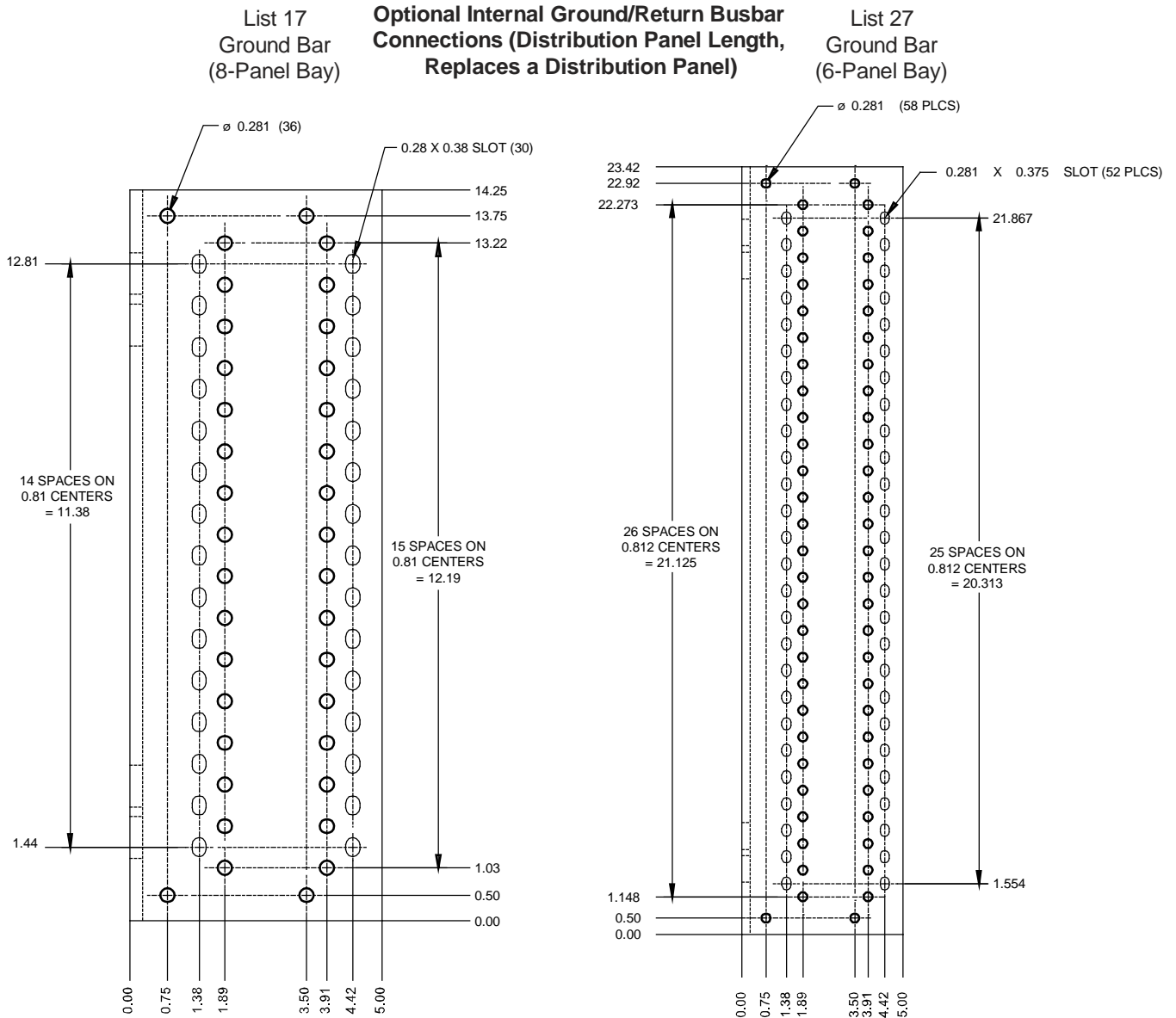

Figure 16 (cont'd from previous page, cont'd on next page)
 Load Distribution Connections



Load Return Connections

1/4" clearance holes/slots on 5/8" centers for installation of customer provided two hole lugs.
(Torque to 72 in-lbs.)
(Maximum Lug Width is 0.610".)
(Maximum Wire Size is 2 AWG.)

Figure 16 (cont'd from previous page, cont'd on next page)
Load Distribution Connections

**Optional Internal
Ground/Return Busbar
Paralleling Bar**

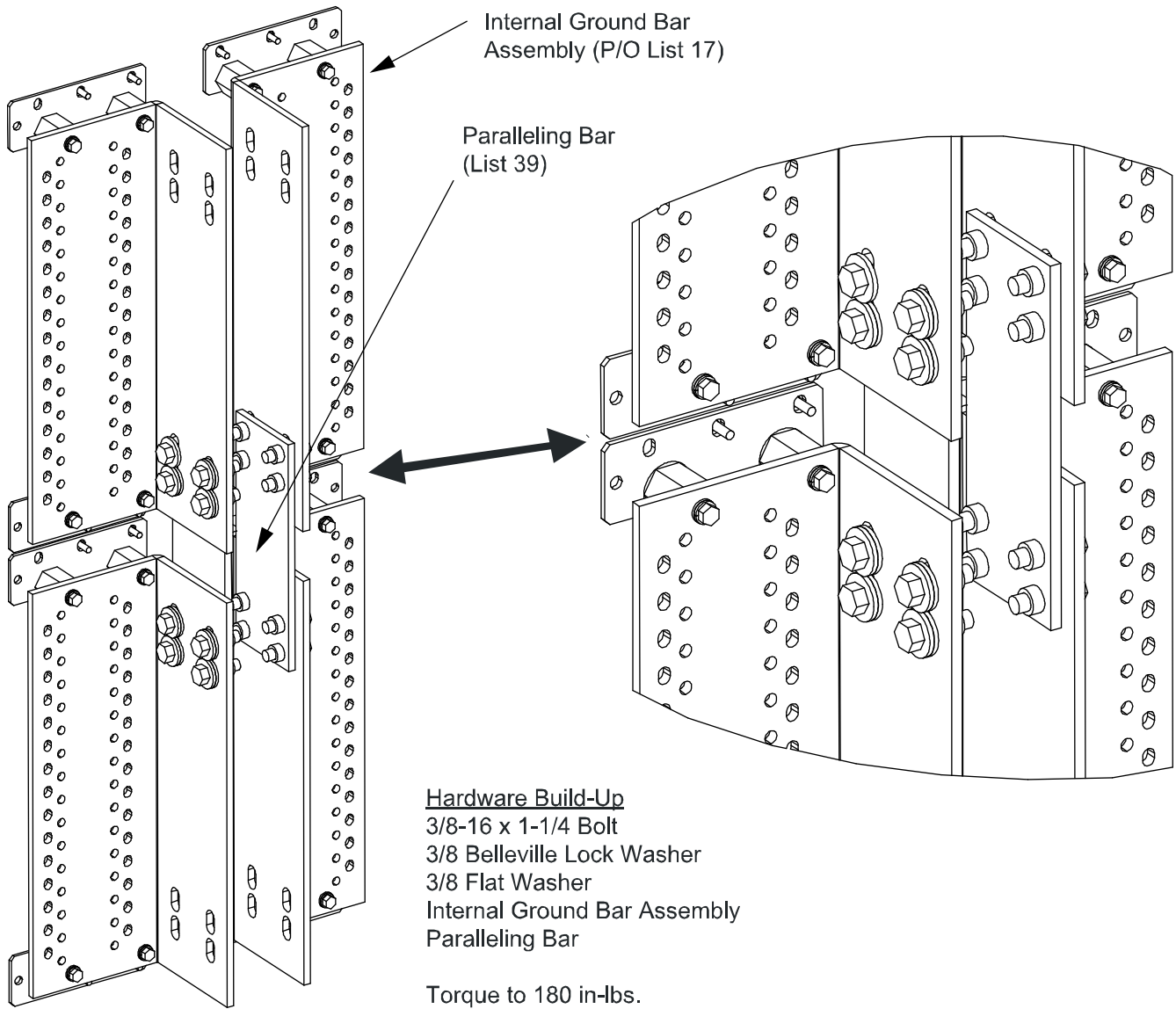

Figure 16 (cont'd from previous page)
Load Distribution Connections

DC Input Connections

General

DC input cable size varies depending on power requirements, therefore no specific information is provided for cable size. Refer to Table 18 for recommended cable sizes and lugs at rated maximum bay load (640 A per distribution panel, 1800 A per side 6-panel bay, 2400 A per side 8-panel bay). Note that loads typically should not exceed 80% of capacity; therefore, input cables have been sized for an overcurrent protection device rated at 800 A. All lugs for customer connections must be ordered separately. Customer needs to supply lug mounting bolts and hardware.

Maximum size of wire to be connected to a single lug position and maximum lug width are as shown in Figure 17.

DC input (-48V) leads terminated in the appropriate lug are connected to the List 43 bay input feed and shunt assembly. See Figure 17. When making connections, observe correct polarity.

DC input return leads terminated in the appropriate lug are connected to the optional internal ground/return bars or to optional external ground/return bars. See Figure 17. When making connections, observe correct polarity.

External Overcurrent Protection Device Rating	Ambient Operating Temperature ⁽¹⁾	Loop Length (Ft) 1.0 Voltage Drop ⁽²⁾	Loop Length (Ft) 0.25 Voltage Drop ⁽²⁾	Recm 90°C Wire Size (AWG) ⁽¹⁾	Recommended Crimp Lug ⁽³⁾
800 A	40 °C	84.5	21.1	750 kcmil	245348100
		168.9	42.2	(2) 750 kcmil	

- ¹ Wire sizes based on recommendations of the American National Standards Institute (ANSI) approved National Fire Protection Association's (NFPA) National Electrical Code (NEC). Table 310.15 (B) (16) for copper wire at 90 °C conductor temperature. For operation in countries where the NEC is not recognized, follow applicable codes.
- ² Recommended wire sizes are sufficient to restrict voltage drop to the voltage shown in the column heading, or less, at rated full load output current of the system for the loop lengths shown in this column. Loop length is the sum of the lengths of the positive and negative leads.
- ³ Two-hole lug, 3/8 bolt clearance hole, 1" centers. Lugs should be crimped per lug manufacturer's specifications.

Table 18
Recommended DC Input Wire Size and Lug Selection

DC Input Connections

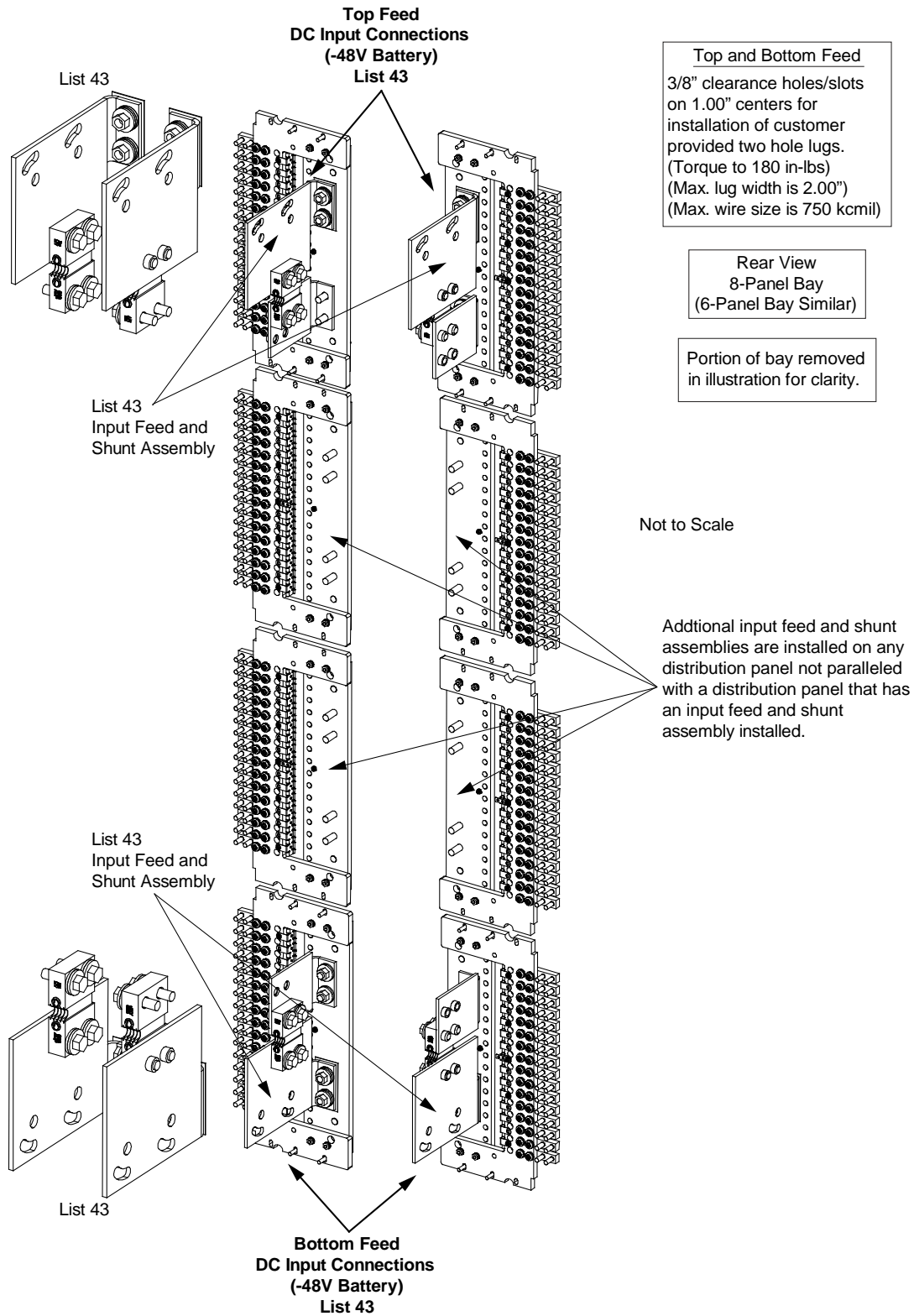

Figure 17 (cont'd on next page)
DC Input Connections

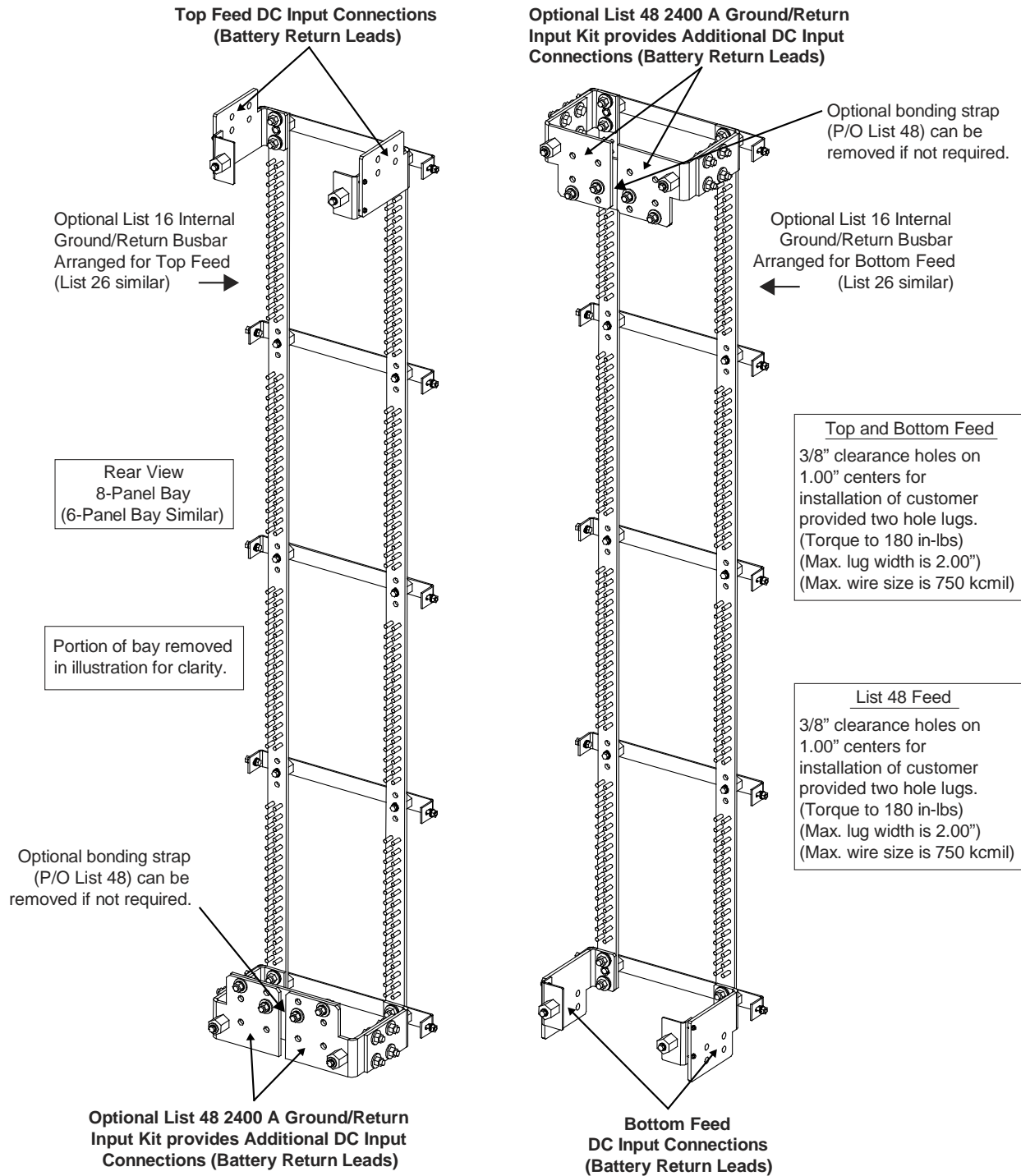

Figure 17 (cont'd from previous page, cont'd on next page)
DC Input Connections

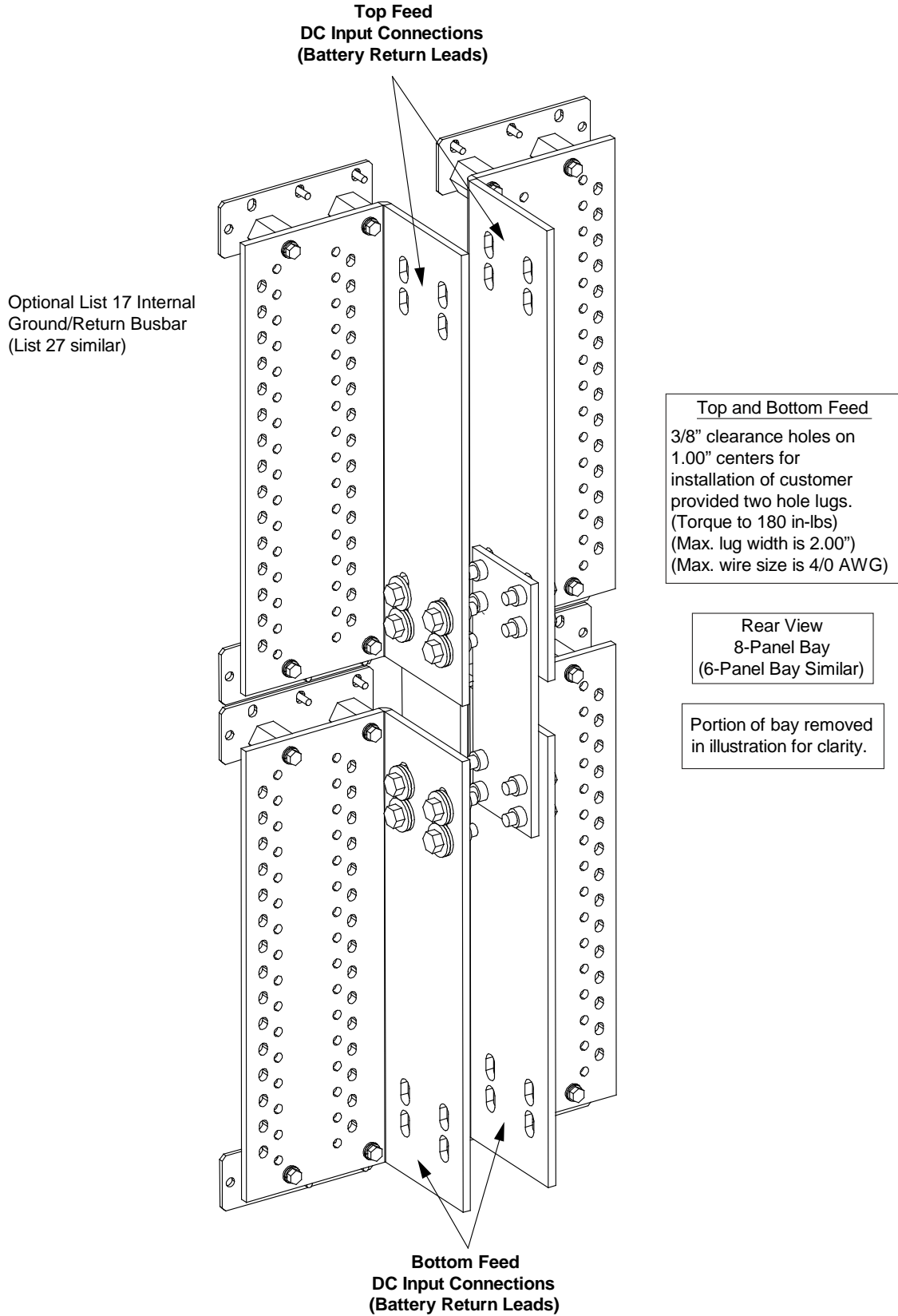

Figure 17 (cont'd from previous page)
DC Input Connections

SPECIFICATIONS

1. SYSTEM

1.1 DC Operating Voltage

1.1.1 Nominal: -48 VDC.

1.1.2 Range: -40 VDC to -59 VDC.

1.2 Environmental Ratings

1.2.1 Operating Ambient Temperature Range: 0 °C to +40 °C (+32 °F to +104 °F).

1.2.2 Storage Ambient Temperature Range: -40 °C to +70 °C (-40 °F to +158 °F).

1.2.3 Relative Humidity: This system is capable of operating in an ambient relative humidity range of 0% to 95%, non-condensing.

1.2.4 Altitude: 0 to 6,000 feet, non-derated.

1.2.5 Audible Noise: Less than 40 dB(A) measured at any point two feet from any vertical surface of a frame and five feet from the floor.

1.2.6 Mounting: Refer to “Mechanical Specifications” starting on page 60 for mounting dimensions.

This product is intended only for installation in a restricted access location on or above a non-combustible surface.

This BDF/CBB uses natural convection. Equipment designed for use in environmentally controlled space.

This product is intended for installation in network telecommunication facilities (CO, vault, hut, or other environmentally controlled electronic equipment enclosure).

This product is intended to be connected to the common bonding network in a network telecommunication facility (CO, vault, hut, or other environmentally controlled electronic equipment enclosure).

The DC return connection to this system can remain isolated from system frame and chassis (DC-I).

Typical industry standards recommend minimum aisle space clearance of 2'6" for the front of the bay and 2' for the rear of the bay.

Ventilating openings must not be blocked and temperature of air entering bay must not exceed rated operating ambient temperature range stated above.

1.3 Compliance Information

1.3.1 Safety Compliance: This BDF/CBB is UL Listed (and "cULus") as a DC Power Distribution Center for Communications Equipment.

1.3.2 NEBS Compliance (Pending): Compliance verified by a Nationally Recognized Testing Laboratory (NRTL) per GR-1089-CORE and GR-63-CORE. Contact Vertiv for NEBS compliance reports.

1.4 Output Ratings

1.4.1 Distribution Panel: 640 A maximum continuous.

1.4.2 8-Panel Bay: 2400 A, maximum, per side.
4800 A, maximum, per bay.

1.4.3 6-Panel Bay: 1800 A, maximum, per side.
3600 A, maximum, per bay.

1.5 Standard Features

1.5.1 Fuse/Circuit Breaker Mounting Positions: See descriptions under “List Descriptions (582140600)” starting on page 10.

1.5.2 Local Controls and Indicators: A status indicator at the top of the bay front panel indicates system status. The monitor unit provides metering functions, monitoring functions, local/remote alarm functions; and connections for binary inputs and programmable relay outputs via an interface board. Refer to the monitor unit's User Manual (UM1M832DNA) for more information.

1.5.3 Meter Accuracy

(A) Current Accuracy: $\leq \pm 0.5\%$ (of 25 mV; Range: 0 mV to 50 mV) for the SMDUE plus 0.25 % for the shunt error. Results in an overall current accuracy of about 0.75 %.

(B) Voltage Accuracy: $\leq \pm 0.10\text{ V}$ (0 V to 60 V).

1.5.4 Advance Panel Current Accuracy: $\pm 0.5\%$ of full scale.

Vertiv™ NetSure™ DC Power Distribution System

System Application Guide

1.5.5 Remote Access: The monitor unit comes with comprehensive webpages for remote access. Each bay includes an IB5 board (second Ethernet port for the monitor unit). The Ethernet port located on the monitor unit can be used to connect a computer directly to the monitor unit. The Ethernet port located on the IB5 board can be used to connect the monitor unit to your Local Area Network (LAN). Refer to the monitor unit's User Manual (UM1M832DNA) for more information.

2. MONITOR UNIT

Refer to the Monitor Unit's User Manual (UM1M832DNA).

For monitor unit factory settings, refer to the configuration drawing (C-drawing).

MECHANICAL SPECIFICATIONS

List 01 and List 07 Floor Hole Drilling Pattern Dimensions

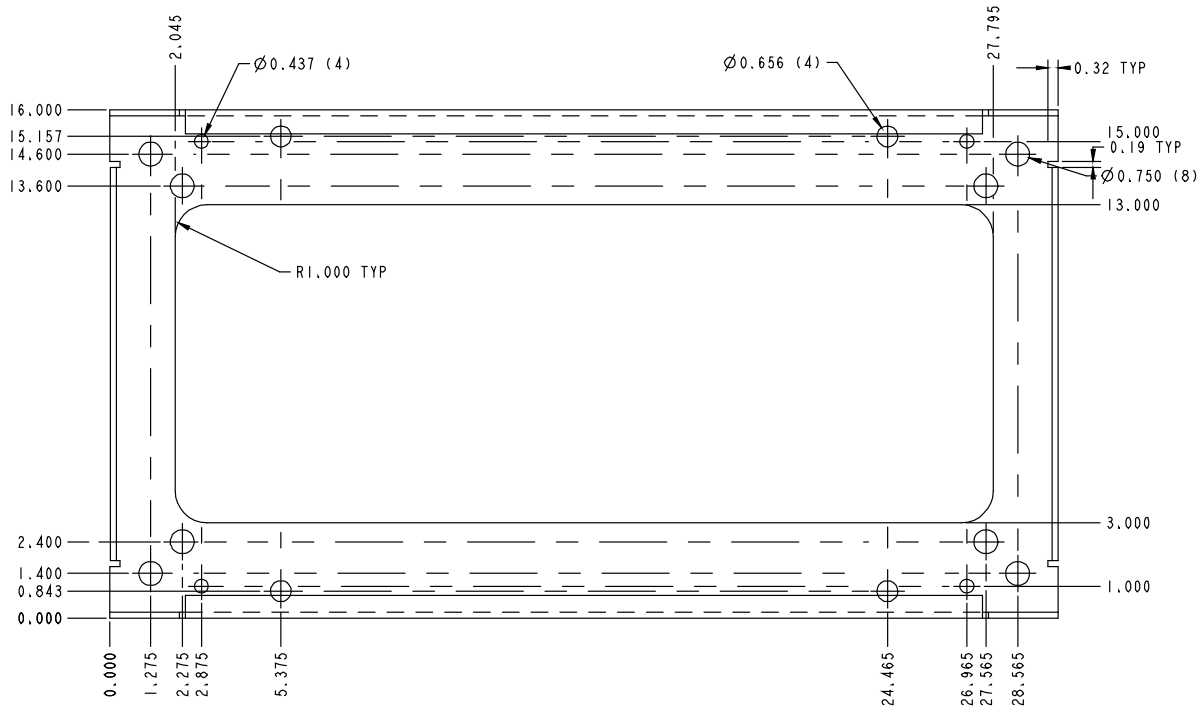

List 03 and List 09 Floor Hole Drilling Pattern Dimensions

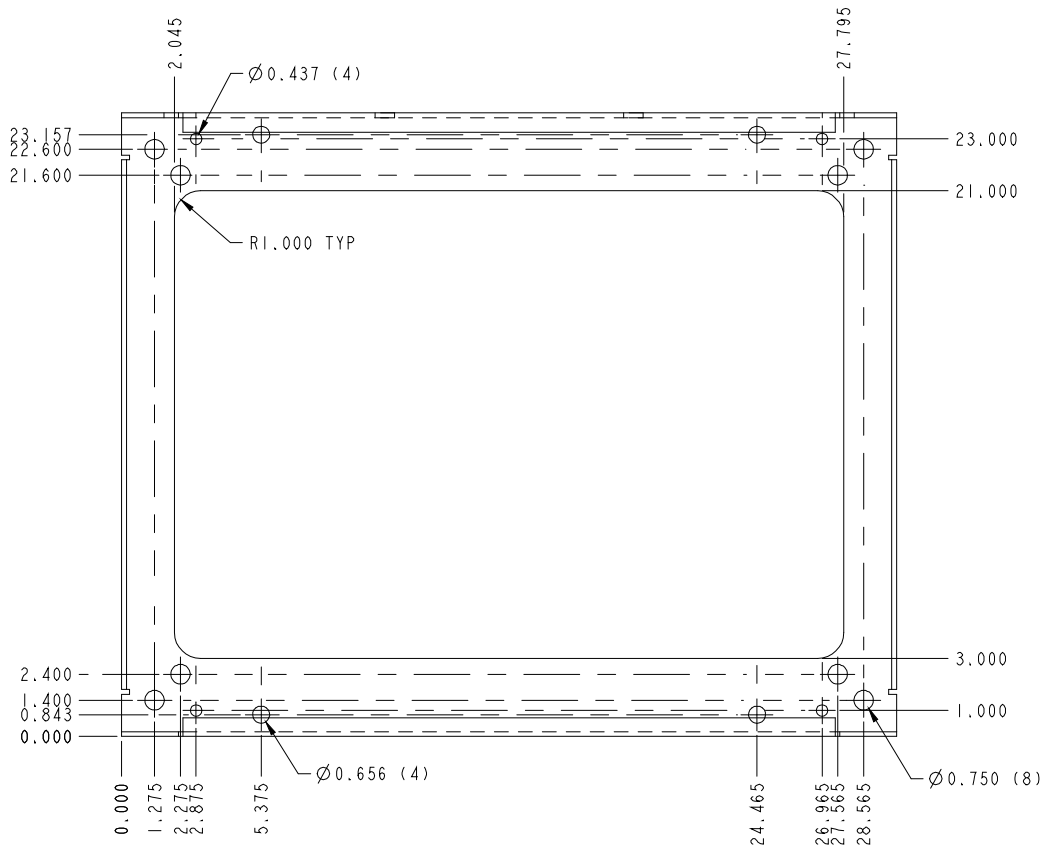

Overall Dimensions, List 01

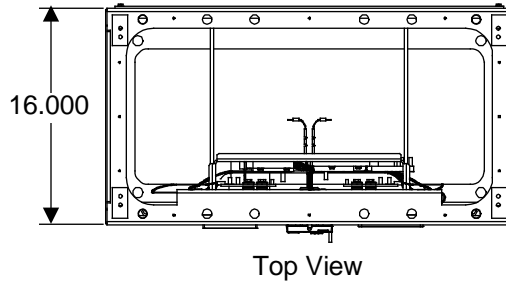

- Notes:
1. All dimensions are in inches, unless otherwise specified.
 2. Finish: Textured Gray.

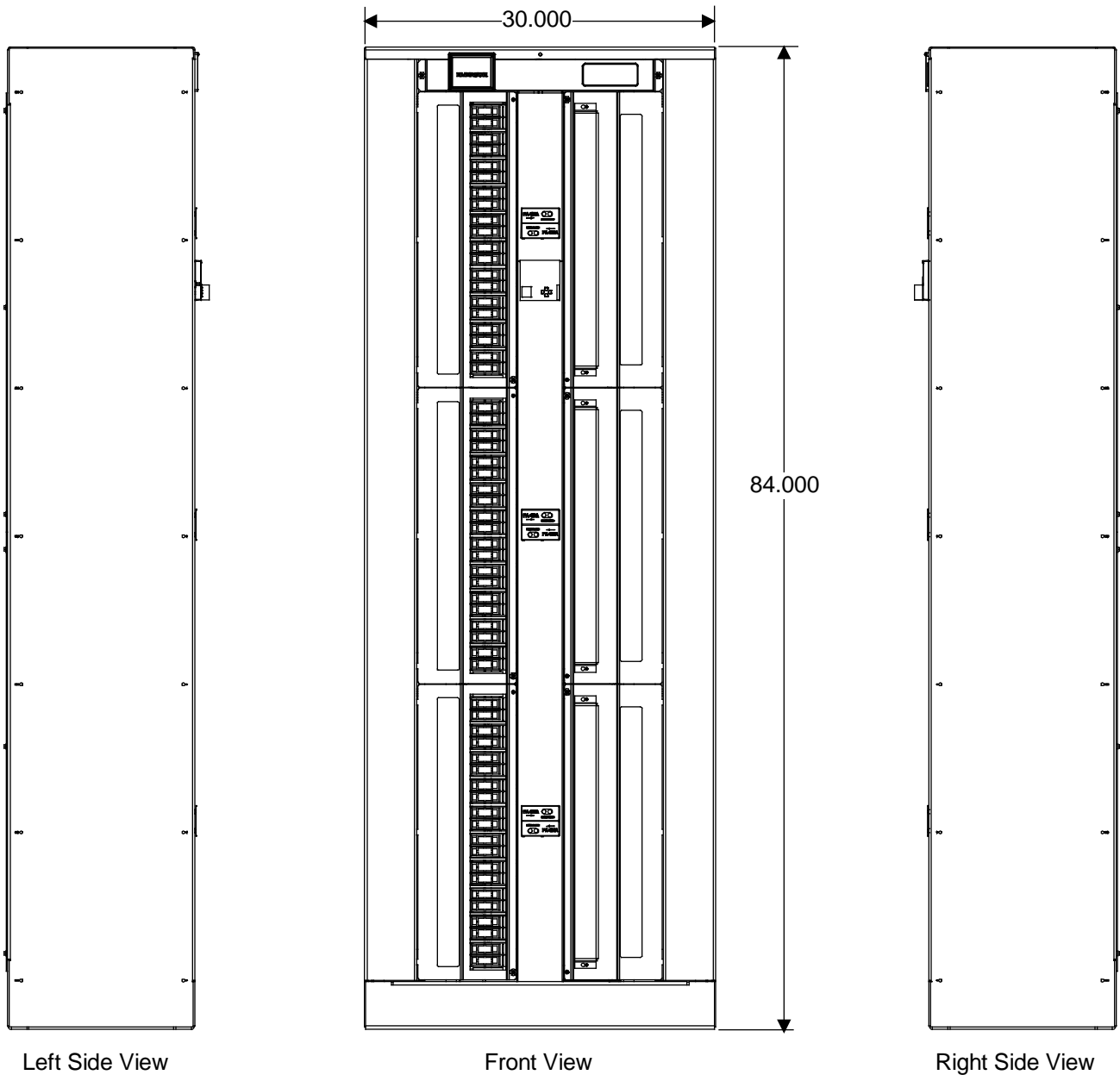

Overall Dimensions, List 03

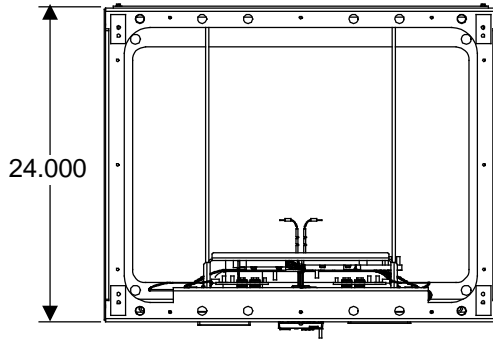

Top View

Notes:

- 1. All dimensions are in inches, unless otherwise specified.
- 2. Finish: Textured Gray.

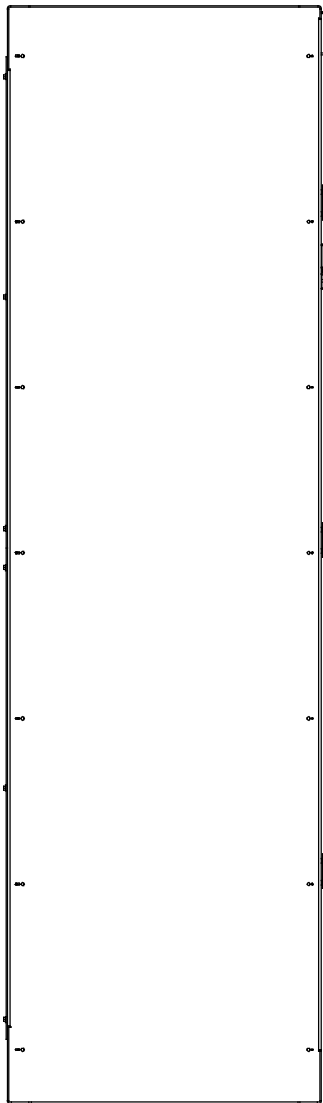

Left Side View

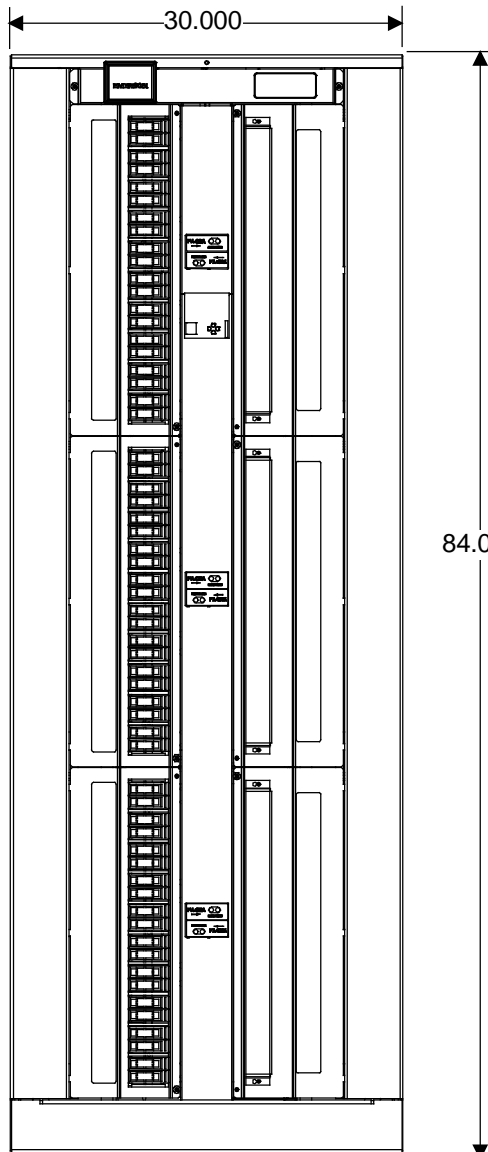

Front View

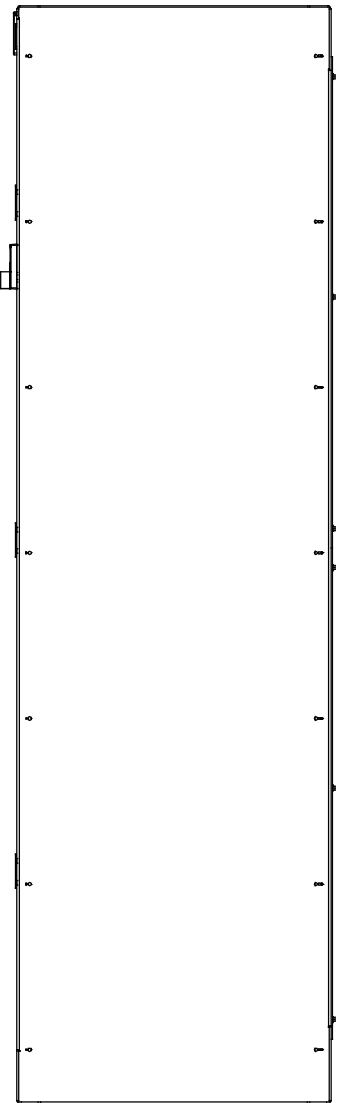

Right Side View

Overall Dimensions, List 07

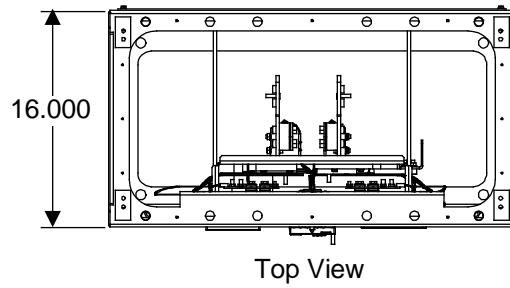

- Notes:
- 1. All dimensions are in inches, unless otherwise specified.
 - 2. Finish: Textured Gray.

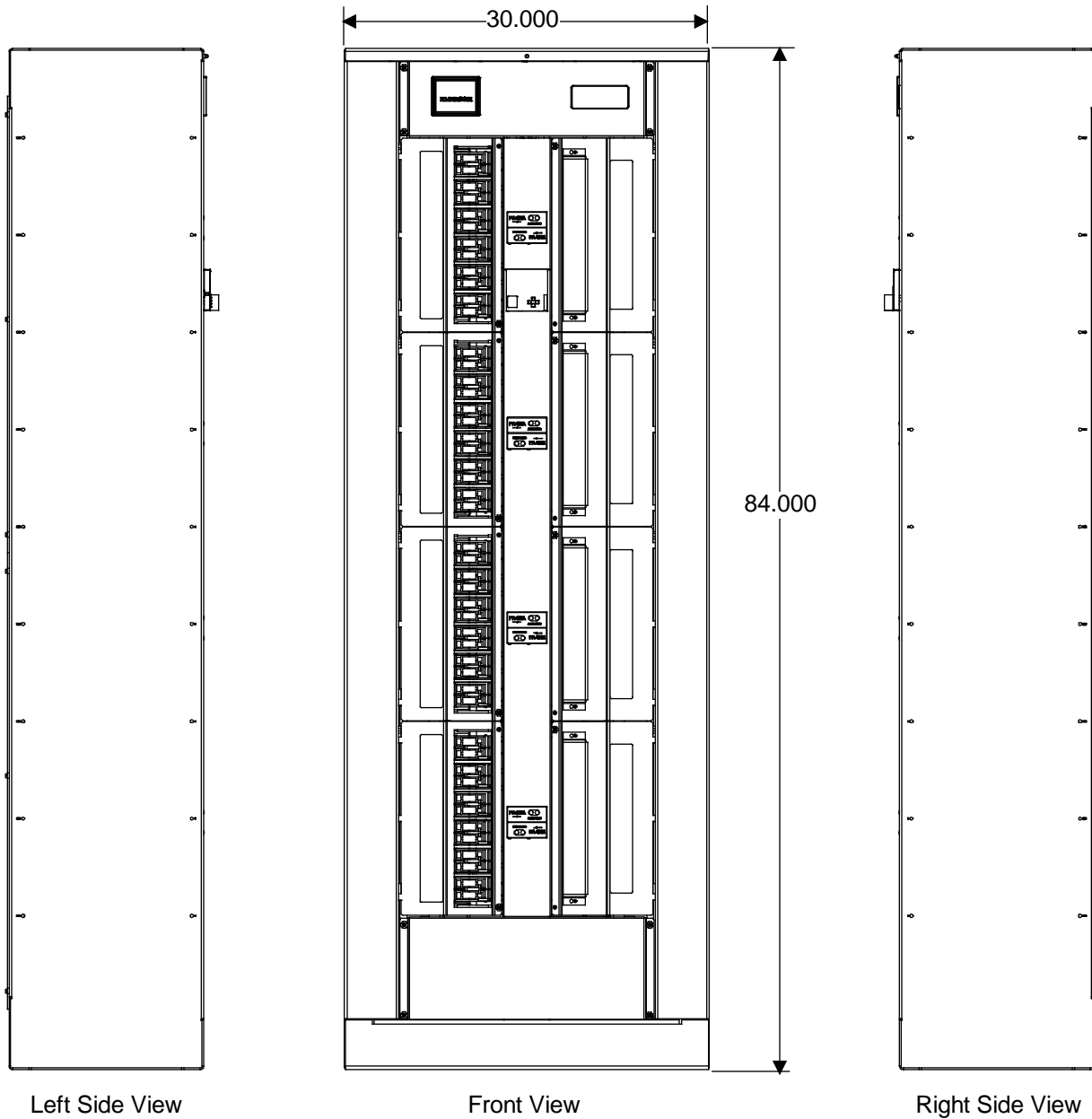

Overall Dimensions, List 09

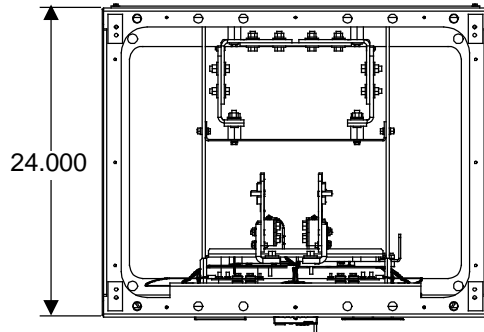

Top View

Notes:

- 1. All dimensions are in inches, unless otherwise specified.
- 2. Finish: Textured Gray.

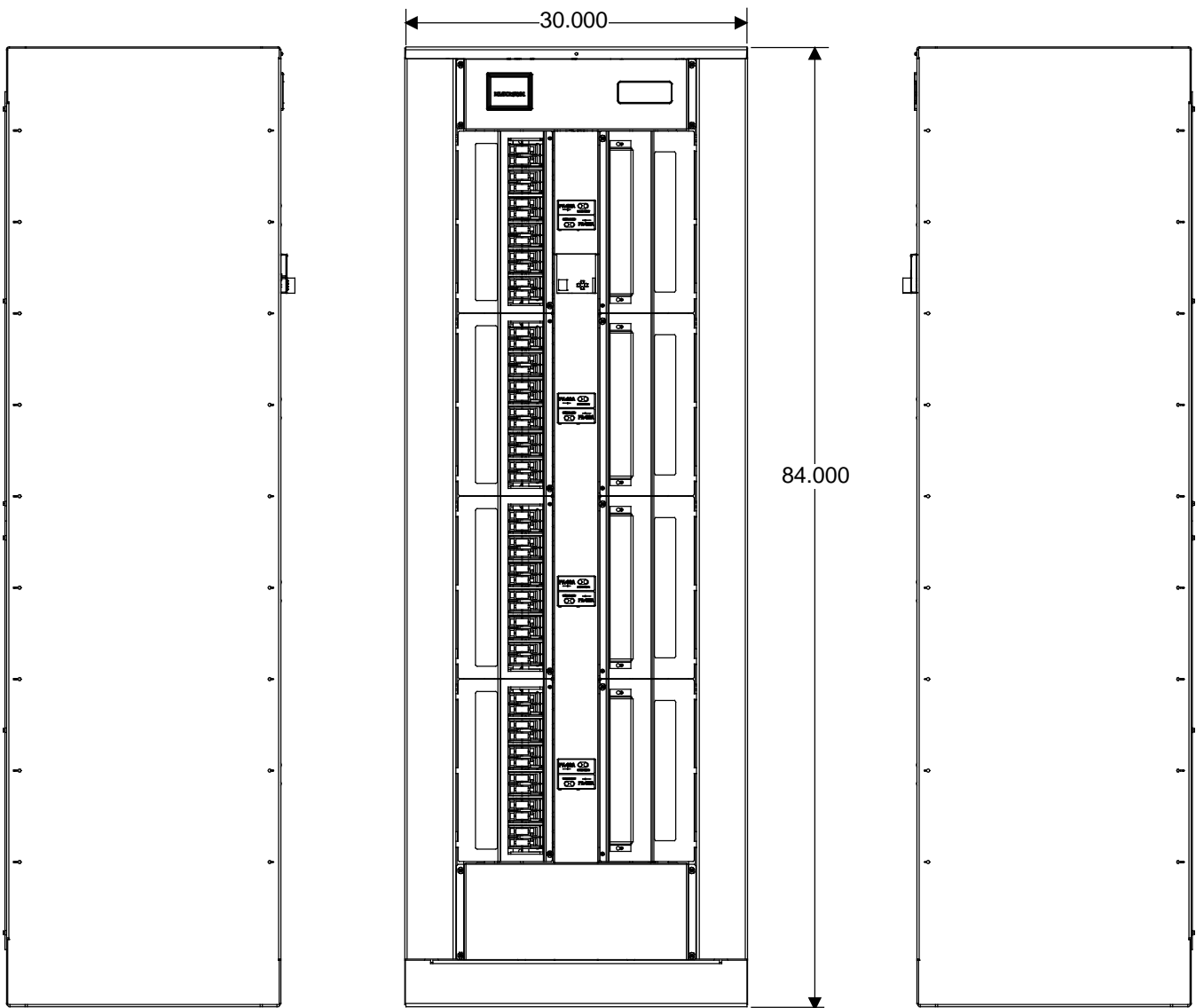

Left Side View

Front View

Right Side View

Vertiv™ NetSure™ DC Power Distribution System
System Application Guide

Weights

List Number or Part Number	Net Weight (lbs), each	Description
BDFB Bays		
58214060001	160	Common Equipment, 6-Panel Bay, 30" W x 16" D x 84" H
58214060003	183	Common Equipment, 6-Panel Bay, 30" W x 24" D x 84" H
58214060007	246	Common Equipment, 8-Panel Bay, 30" W x 16" D x 84" H
58214060009	270	Common Equipment, 8-Panel Bay, 30" W x 24" D x 84" H
Monitor Unit		
UM1M832DNA	1.2	Monitor Unit
Distribution Panels		
58214060010	12.8	TLS/TPS Fuse and/or TPL-B Fuse Distribution Panel, 8-Panel Bay
58214060015	12.8	Bullet Breaker and/or TLS/TPS Fuse Distribution Panel, 8-Panel Bay
58214060015A	15.8	Bullet Breaker and/or TLS/TPS Fuse Distribution Panel, 8-Panel Bay
58214060020	22	TLS/TPS Fuse and/or TPL-B Fuse Distribution Panel, 6-Panel Bay
58214060025	22	Bullet Breaker and/or TLS/TPS Fuse Distribution Panel, 6-Panel Bay
58214060025A	25.4	Bullet Breaker and/or TLS/TPS Fuse Distribution Panel, 6-Panel Bay
Option Internal Ground Bars (Full Bay Length)		
58214060016	25	Optional Internal Ground/Return Bar, 8-Panel Bay (Full Bay Length)
58214060026	30	Optional Internal Ground/Return Bar, 6-Panel Bay (Full Bay Length)
Option Internal Ground Bars (Panel Length)		
58214060017	26	Optional Internal Ground/Return Bar, 8-Panel Bay (Panel Length)
58214060027	38	Optional Internal Ground/Return Bar, 6-Panel Bay (Panel Length)
Blank Distribution Panel Cover		
58214060018	2	Blank Distribution Panel Cover, 8-Panel Bay
58214060028	3	Blank Distributional Panel Cover, 6-Panel Bay
Other Items		
58214060030	3	Distribution Panel Paralleling Bar
58214060031	2.4	Distribution Panel Paralleling Bar
58214060039	13	Optional Internal Ground/Return Bar Paralleling Kit, 8-Panel Bay (Panel Length)
58214060043	28	Bay Input Feed and Shunt Assembly (4 Cables, 25 mV Shunts)
58214060048	19	2400 A Ground/Return Input Assembly, with Optional Bonding Strap
58214060051	3	Dressing Bar, 16" Deep Bays
58214060052	4	Dressing Bar, 24" Deep Bays
58214060053	25	Load Distribution Cable Management Kit
58214060054	2	Top Cover, 16" Deep
58214060055	2	Top Cover, 24" Deep

RELATED DOCUMENTATION

System Installation and User Instructions:	UM582140600
Monitor Unit Instructions:	UM1M832DNA
System Schematic Diagram:	SD582140600
System Wiring Diagram:	T582140600

Vertiv.com | Vertiv Headquarters, 505 N Cleveland Ave, Westerville, OH 43082, USA

© 2026 Vertiv Group Corp. All rights reserved. Vertiv™ and the Vertiv logo are trademarks or registered trademarks of Vertiv Group Corp. All other names and logos referred to are trade names, trademarks or registered trademarks of their respective owners. While every precaution has been taken to ensure accuracy and completeness here, Vertiv Group Corp. assumes no responsibility, and disclaims all liability, for damages resulting from use of this information or for any errors or omissions.

