

SYSTEM OVERVIEW

Description: -48 VDC @ up to 16000 Amperes Power System

The Vertiv™ NetSure™ 8200NLDB (208V Input Power/Distribution and Power Only Bays), Vertiv™ NetSure™ 8200NLEB (480V Input Power/Distribution and Power Only Bays), and Vertiv™ NetSure™ 8200NL-B (Distribution Only Bay) DC Power System is an integrated power system containing rectifiers, intelligent control, metering, monitoring, and distribution.

This power system is designed to power a load while charging a positive grounded battery. The power system is capable of operating in a batteryless installation or off battery for maintenance purposes. The power system is designed for operation with the positive output grounded.

This power system can consist of the following components. The system must consist of one (1) primary power/distribution bay or primary power only bay and may consist of up to seven (7) additional bays. These additional bays may be a combination of secondary power/distribution bays, secondary power only bays, and/or distribution only bays (maximum of 4 distribution only bays per system). The system can be expanded right or left.

- **Power/Distribution Bays and Power Only Bays**

Each power/distribution bay and power only bay can be equipped with up to ten (10) rectifiers. The power/distribution bay and power only bay can be ordered factory configured for various AC input options. The power/distribution bay also provides distribution. Distribution is divided into two buses which accept a choice of fuse and circuit breaker types and sizes.

Each power/distribution bay and power only bay contains a monitor and control shelf. The monitor and control shelf either contains an NCU controller (main bay) or NCU controller interface (secondary bays). The SM-DUE module is mounted in each secondary bay's control shelf. Refer to "**SM-DUE (if furnished)**" on page 2. An indicator is visible from the outside of the bay (at the top) which illuminates if an alarm condition occurs.

The primary power/distribution bay or primary power only bay contains a front panel touch screen display connected to the NCU controller. The primary bay also includes an NCU interface board (IB2) which provides digital inputs, temperature inputs, and relay outputs for internal and external monitoring and alarms. An NCU extended interface board (EIB) is also provided for additional inputs/outputs connections. Also furnished is the IB5 board which provides a second Ethernet port. The Ethernet port located on the NCU controller's front panel is used to connect the front panel touch screen display directly to the NCU. The Ethernet port located on the IB5 board can be used to connect the NCU to your Local Area Network (LAN) for remote access.



NOTE! *IB5 boards with a 10M/100M/1G Ethernet port replaced IB4 boards with a 10M/100M Ethernet port. This transition enables the support of connected devices that communicate up to 1G. While both boards are physically interchangeable, the IB5 board does require the NCU to have V12.80 or higher software loaded.*

- **Distribution Only Bays**

Each distribution only bay provides four (4) distribution buses. Each distribution bus accepts a choice of 218-type circuit breakers and TPL-type fuses. A List 116 distribution only bay may also be equipped with an optional distribution panel which accepts a choice of TPS/TLS-type fuseholders or bullet nose-type circuit breakers. An indicator is visible from the outside of the distribution only bay (at the top) which illuminates if a fuse or circuit breaker in the bay opens.

- **Rectifiers**

The system contains rectifiers, which provide load power, battery float current, and battery recharge current during normal operating conditions.

- **NCU Controller**

The NCU controller provides power system control, rectifier control (including a charge control function), metering functions, monitoring functions, and local/remote alarm functions. The controller also supports rectifier temperature compensation if the system is equipped with a temperature probe(s). Temperature probe(s) may also be designated to monitor ambient temperature and/or battery temperature. The controller also provides data acquisition, system alarm management, and advanced battery and energy management. The controller contains a color TFT display and keypad for local access. The controller provides an Ethernet port and comes with comprehensive webpages for remote access. The controller has SNMP v3 capability

for remote system management. The controller supports software upgrade via its USB port. Refer to the NCU controller instructions (UM1M830BNA) for more information.

Note: In this system, the NCU Ethernet port is connected to a front panel touch screen PC for local access to the NCU webpages. An IB5 (second Ethernet port board) is also furnished which provides a connection point for a remote monitoring Ethernet connection.

- **SM-DUE (if furnished)**

The SM-DUE is used to input external monitoring information to the NCU controller. The SM-DUE provides the following monitoring inputs:

Ten (10) input blocks with each providing the following monitoring inputs:

One (1) Load Bus Voltage (0 VDC to 60 VDC) per input block

One (1) Load Fuse Alarm (Bus- base of 0 VDC, >10 VDC alarm, <10 VDC normal) per input block

One (1) Programmable Analog Input, can be set to accept one (1) of the following inputs per input block:

10 mV DC to 50 mV DC Load Shunt (only load shunts are supported at this time)

General-Purpose Current Transducer

General-Purpose Voltage Transducer

1 uA/K Temperature Sensor

The SM-DUE also contains a +5 VDC power supply output for connection to external Hall devices. The SM-DUE connects into the NCU CAN bus. Up to eight (8) SM-DUE units can be connected to an NCU.

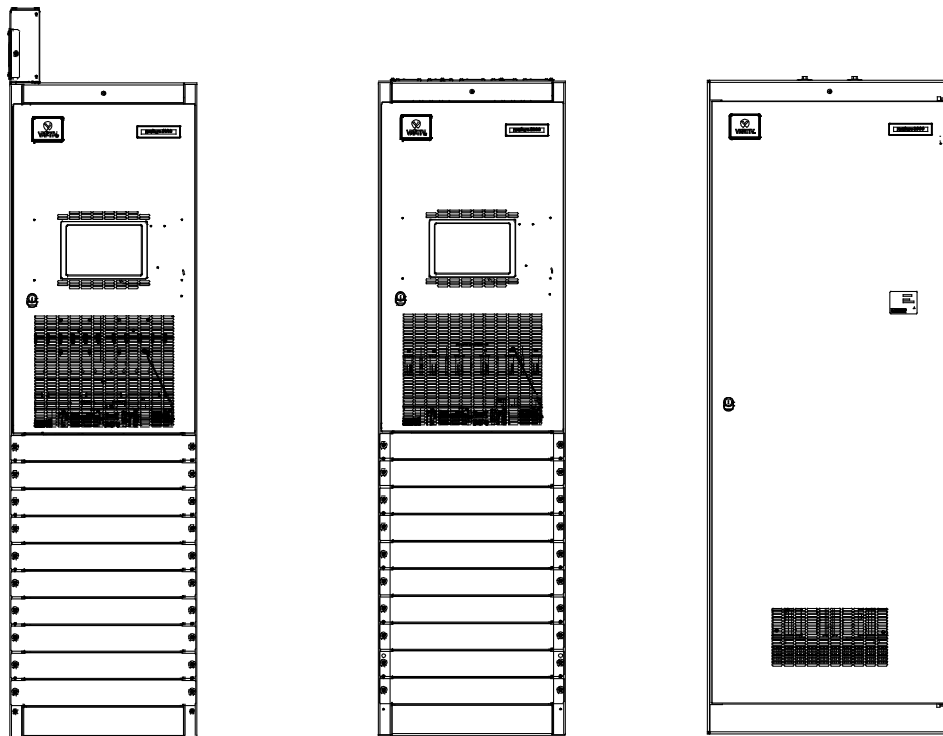

Primary Power/Distribution Bay
Secondary Bay Similar

Primary Power Only Bay
Secondary Bay Similar

Distribution Only Bay

Vertiv™ NetSure™ 8200 -48 VDC Power System

System Application Guide

General Specifications

See detailed specifications on page 98.

Family:	Vertiv™ NetSure™
Spec. No.:	582140000
Model:	8200NLDB (208V Input Power/Distribution and Power Only Bays) (NCU Controller) 8200NLEB (480V Input Power/Distribution and Power Only Bays) (NCU Controller) 8200NL-B (Distribution Only Bay) (NCU Controller)
Input Voltage	<u>R48-12000e</u> : Nominal 480 volts AC, three phase, 60 Hz, with an operating range of 340 to 528 volts. Acceptable input frequency range is 57 to 63 Hz. or <u>R48-12000Le</u> : Nominal 208 volts AC, three phase, 60 Hz, with an operating range of 176 to 264 volts. Acceptable input frequency range is 47 to 63 Hz.
Output Voltage:	-48 Volts DC
Output Capacity:	
System:	16,000 Amperes, maximum
Power Only Bay:	2200 Amperes, maximum
Power/Distribution Bay:	2400 Amperes, maximum
Distribution Bus (two Distribution Buses per Power/Distribution Bay):	1200 Amperes
Rectifier:	200 A / -48 V
Distribution Only Bay:	6000 Amperes, maximum
Distribution Bus: (four Distribution Buses per Distribution Only Bay)	1500 Amperes, maximum
Optional Distribution Panel: (Bullet Nose Circuit Breakers and/or TLS/TPS Fuses) (one optional Distribution Panel per Distribution Only Bay)	500 Amperes, maximum
Agency Approval:	Power/Distribution Bay and Distribution Only Bay: Listed UL 1801, NEBS Power Only Bay: UL 60950, NEBS
Framework Type:	Seismic Rated (Zone 4) Box Framework
Power/Distribution Bay:	
Width:	24", plus 10" if PDSC used
Depth:	30"
Height:	93.5" List 101, 111 84" List 102, 112
Access:	
Single Bay Plants:	Front Access for Installation, Maintenance, and Operation.
Multi-Bay Plants:	Front and Rear Access for Installation and Maintenance, Front for Operation.
Power Only Bay:	
Width:	24"
Depth:	30"
Height:	84"
Access:	
Single Bay Plants:	Front Access for Installation, Maintenance, and Operation.
Multi-Bay Plants:	Front and Rear Access for Installation and Maintenance, Front for Operation.

Vertiv™ NetSure™ 8200 -48 VDC Power System

System Application Guide

Distribution Only Bay:	
Width:	31.375"
Depth:	30"
Height:	84"
Access:	Front and Rear Access for Installation and Maintenance, Front for Operation.
Secondary Bay(s) Available:	Seven
Distribution Only Bay(s) Available:	Four
Control:	Microprocessor
Color (8200 Series):	Textured Dark Gray
Environment:	0 °C to +40 °C (+32 °F to +104 °F)

TABLE OF CONTENTS

SYSTEM OVERVIEW 1

TABLE OF CONTENTS 5

MAIN COMPONENTS ILLUSTRATIONS..... 8

 582140000 Primary Power/Distribution Bay 8

 582140000 Secondary Power/Distribution Bay 9

 582140000 Primary Power Only Bay..... 10

 582140000 Secondary Power Only Bay 11

 582140000 Distribution Only Bay 12

 582140000 Distribution Only Bay 13

 582140000 Primary and Secondary Power/Distribution and Power Only Bays Monitor/Control Diagram (List 101, 102, 103, 104, 105, 111, 112, 113, 114, 115) 14

 582140000 Distribution Only Bays Monitor and Control Diagram (List 116)..... 15

 582140000 Distribution Only Bays Monitor and Control Diagram (List 117, 118, 122) 15

LIST DESCRIPTIONS 16

 List Numbers..... 16

 List A: 480 VAC Plant Input Voltage 16

 List B: 208 VAC Plant Input Voltage 16

 List 101: Primary Power/Distribution Bay (Common Equipment)..... 16

 List 102: Primary Power/Distribution Bay (Common Equipment)..... 17

 List 103: Primary Power Only Bay, Five (5) AC Feeds (Common Equipment) 17

 List 104: Primary Power Only Bay, Two (2) AC Feeds (Common Equipment) 18

 List 105: Primary Power Only Bay, Ten (10) AC Feeds (Common Equipment) 19

 List 111: Secondary Power/Distribution Bay (Common Equipment)..... 19

 List 112: Secondary Power/Distribution Bay (Common Equipment)..... 20

 List 113: Secondary Power Only Bay, Five (5) AC Feeds (Common Equipment)..... 21

 List 114: Secondary Power Only Bay, Two (2) AC Feeds (Common Equipment) 22

 List 115: Secondary Power Only Bay, Ten (10) AC Feeds (Common Equipment) 23

 List 116: Distribution Only Bay (Cable Only Bay) Left or Right 23

 List 117: 2nd Internal Bus Distribution Only Bay – Expansion to the Right or Left 24

 List 118: 1st Internal Bus Distribution Only Bay – Expansion to the Right..... 25

 List 119: Distribution Only Bay Expansion Busbars to Bridge PDSC..... 25

 List 122: 1st Internal Bus Distribution Only Bay – Expansion to the Left 25

 List 130: Optional 480 VAC Input Bolt-On PDSC (AC Input 'Power Distribution Service Cabinet') 26

 List 131: Optional 480 VAC Input Bolt-On PDSC (AC Input 'Power Distribution Service Cabinet') 26

 List 132: Optional 208 VAC Input Bolt-On PDSC (AC Input 'Power Distribution Service Cabinet') 26

 List 35: Surge Suppression for 480 VAC Input PDSC..... 27

 List 36: Surge Suppression for 208 VAC Input PDSC..... 27

 List 37: Surge Suppression for 208 VAC Input 27

 List 38: Surge Suppression for 480 VAC Input 28

 List C: 24 Position Bullet-Nose Circuit Breaker/Fuse Panel 29

ACCESSORY DESCRIPTIONS 30

 Rectifiers 30

 P/N 486532603, Rectifier (480 VAC Input)..... 30

 P/N 486534003, Rectifier (208VAC Input)..... 30

 External Main Termination Bars 30

 Distribution Devices and Load Lug Locations - Power/Distribution Bays 31

 Distribution Device and Load Lug Locations – Distribution Only Bays 33

 Distribution Devices..... 36

 218 Circuit Breaker Assemblies 36

 TPL Fuses and Fuseholder Assemblies 40

 Bullet Nose-Type Circuit Breakers and Bullet Nose-Type Circuit Breaker/Fuseholder Mounting Assembly – Power/Distribution Bays 43

 TLS/TPS Fuses, Bullet Nose-Type Fuseholders, and Bullet Nose-Type Circuit Breaker/Fuseholder Mounting Assembly – Power/Distribution Bays 46

 Bullet Nose-Type Circuit Breakers and Bullet Nose-Type Fuseholders e/w TLS/TPS Fuses – Distribution Only Bays 49

Vertiv™ NetSure™ 8200 -48 VDC Power System

System Application Guide

Optional Bullet Nose-Type 10-Position GMT Fuse Module for List C.....	51
Replacement Alarm, Reference, and Control Fuses (List 101, 102, 103, 104, 105, 111, 112, 113, 114, 115, 116, 117, 118, 122)	52
Located in Bay's Center Section	52
Input and Alarm Fuse on Optional Bullet Nose-Type 10-Position GMT Fuse Module, P/N 509128	53
Optional Power/Distribution Bay Internal Ground Busbar Kits	54
Optional Internal Ground Busbar Kit (P/N 554862)	54
Optional Internal Ground Busbar Kit (P/N 555214).....	55
Power/Distribution and Power Only Bays External Busbars.....	56
Optional External Top-Mount Horizontal Battery Input Busbar Assembly.....	56
Optional Busbar Shield Kit.....	56
Optional External Top-Mount Ground (Load Return) Busbar Assemblies.....	57
Optional Load Return Lug Extension Busbar Assembly.....	58
Optional External Top-Mount Vertical Battery Input Busbar Assembly.....	63
Optional Temperature Probes (List 101, 102, 103, 104, 105 Only).....	66
Optional SM-Temp Temperature Concentrator, P/N 547490	66
Optional SM-IO2, P/N 02440103	67
Optional SM-DU+, P/N 10010507.....	68
Replacement/Additional Network Cable (List 111, 112, 113, 114, 115, 116, 117, 118, 122 Only).....	69
Primary Bay NCU Retrofit Kit, P/N 565406	69
Secondary Bay NCU Retrofit Kit, P/N 565408	69
Distribution Only Bay NCU Retrofit Kit, P/N 566156	69
Distribution Only Bay NCU Retrofit Kit, P/N 566157	70
User Replaceable Components.....	73
Models 8200NLDB, 8200NLEB and 8200NL-B.....	73
Wiring Components.....	74
Power/Distribution and Power Only Bays Frame Grounding Wire Sizes and Lugs.....	74
Distribution Only Bay Frame Grounding Wire Sizes and Lugs Selection.....	75
Power/Distribution Bay and Distribution Only Bay Load Distribution Wire Sizes and Lugs.....	76
Power/Distribution Bay Battery Cable Sizes and Lugs	80
Power Only Bay DC Output Cable Sizes and Lugs.....	82
Distribution Only Bay DC Input Cable Sizes and Lugs Selection.....	84
Power/Distribution Bay AC Input, Ten (10) AC Feeds Wire Sizes, Branch Circuit Protection, and Lugs.....	86
Power/Distribution Bay AC Input, Two (2) AC Feeds Wire Sizes, Branch Circuit Protection, and Lugs	88
Power/Distribution Bay AC Input, One (1) AC Feed Wire Sizes, Branch Circuit Protection, and Lugs.....	90
Power Only Bay AC Input, Five (5) AC Feeds Wire Sizes, Branch Circuit Protection, and Lugs.....	92
Power Only Bay AC Input, Two (2) AC Feeds Wire Sizes, Branch Circuit Protection, and Lugs	94
Power Only Bay AC Input, Ten (10) AC Feeds Wire Sizes, Branch Circuit Protection, and Lugs.....	96
External Alarm, Reference, and Control Wire Sizes - Power/Distribution and Power Only Bays (List 101, 102, 103, 104, 105).....	98
SPECIFICATIONS.....	103
1. System.....	103
1.1 DC Operating Voltage.....	103
1.2 Environmental Ratings.....	103
1.3 Compliance Information.....	105
1.4 Local Controls and Indicators	105
2. DC Distribution.....	105
2.1 Ratings	105
3. Rectifier	106
3.1 Output Ratings.....	106
3.2 Input Ratings (480VAC, with 486532603 rectifier).....	106
3.3 Input Ratings (208VAC, with 486534003 rectifier).....	107
3.4 Standard Features.....	108
4. NCU Controller	111
4.1 Specifications	111
4.2 Configuration	111
4.3 IB2 and EIB (NCU Interface Board) Ratings.....	111
4.4 SM-DUE Ratings	111
PHYSICAL SIZE INFORMATION.....	114
Overall Dimensions.....	114

Vertiv™ NetSure™ 8200 -48 VDC Power System

System Application Guide

Floor Hole Drilling Pattern Dimensions - Power/Distribution Bay and Power Only Bay (without AC Input Service Cabinet)	114
Floor Hole Drilling Pattern Dimensions - Power/Distribution Bay and Power Only Bay (with AC Input Service Cabinet)	114
Floor Hole Drilling Pattern Dimensions - Distribution Only Bay	115
Primary and Secondary Power/Distribution Bays (List 101, 111)	116
Primary and Secondary Power/Distribution Bays (List 102, 112)	117
(AC Input 'Power Distribution Service Cabinet')	118
Primary and Secondary Power Only Bays (List 103, 104, 105, 113, 114, 115)	119
Distribution Only Bays (List 116, 117, 118, 122)	120
Optional Temperature Probes (List 101, 102, 103, 104, 105 Only)	121
RELATED DOCUMENTATION	122
Models 8200NLDB, 8200NLEB and 8200NL-B	122

MAIN COMPONENTS ILLUSTRATIONS

582140000 Primary Power/Distribution Bay

[List 130](#): Optional 480 VAC Input Bolt-On PDSC (22kAIC)

[List 131](#): Optional 480 VAC Input Bolt-On PDSC (65kAIC)

[List 132](#): Optional 208 VAC Input Bolt-On PDSC (65kAIC)

[List 35](#): Surge Suppression Option (480 VAC Input PDSC)

[List 36](#): Surge Suppression Option (208 VAC Input PDSC)

[List 101](#): Primary Power/Distribution Bay (e/w AC Input Termination Panel with Ten [10] AC Feeds)

[List 102](#): Primary Power/Distribution Bay (for use with optional bolt-on PDSC)

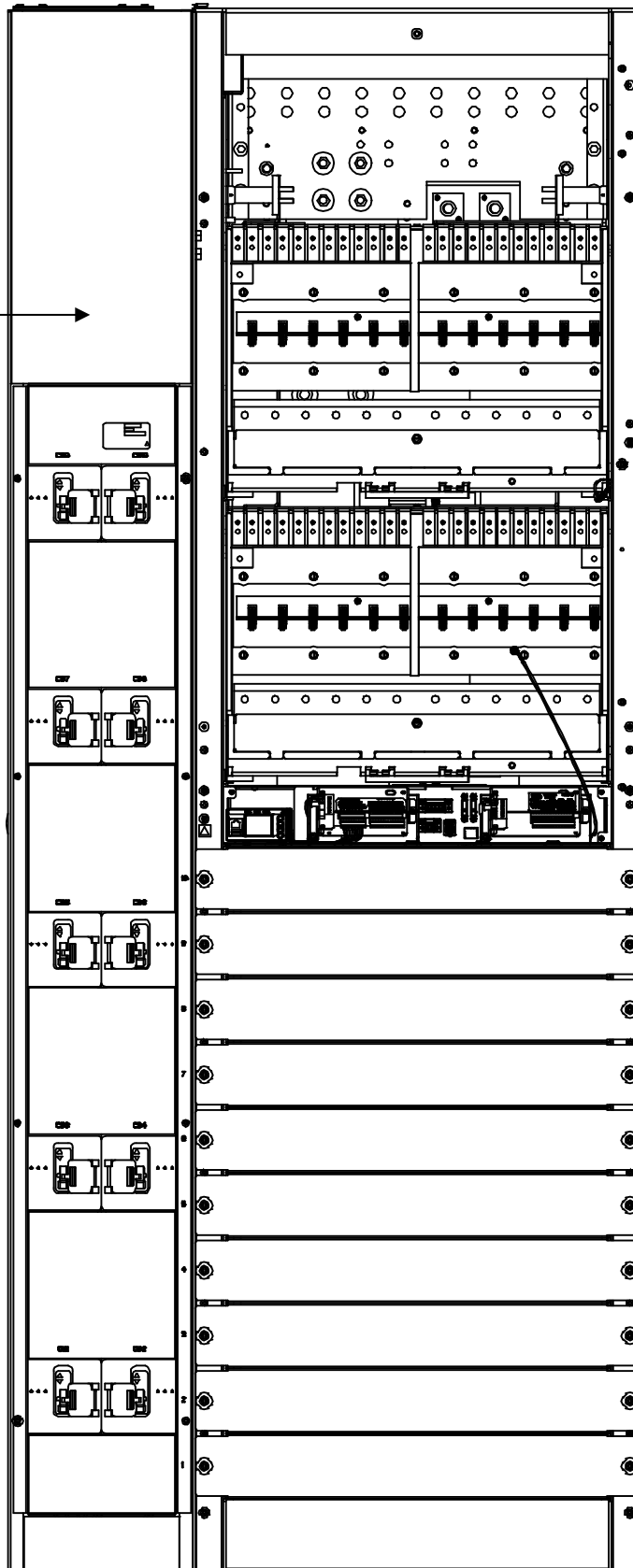

[List A](#): 480 VAC Plant Input

[List B](#): 208 VAC Plant Input

Distribution Bus (see [Distribution Devices](#) in *ACCESSORY DESCRIPTIONS* Section for distribution options)

Distribution Bus (see [Distribution Devices](#) in *ACCESSORY DESCRIPTIONS* Section for distribution options)

(see [Monitor/Control Diagram](#))

Door removed in illustration for clarity.

[P/N 486532603](#): Rectifier (480 VAC Input)

[P/N 486534003](#): Rectifier (208 VAC Input)

Front View

582140000 Secondary Power/Distribution Bay

[List 130](#): Optional 480 VAC Input Bolt-On PDSC (22kAIC)

[List 131](#): Optional 480 VAC Input Bolt-On PDSC (65kAIC)

[List 132](#): Optional 208 VAC Input Bolt-On PDSC (65kAIC)

[List 35](#): Surge Suppression Option (480 VAC Input PDSC)

[List 36](#): Surge Suppression Option (208 VAC Input PDSC)

[List 111](#): Secondary Power/Distribution Bay (e/w AC Input Termination Panel with Ten [10] AC Feeds)

[List 112](#): Secondary Power/Distribution Bay (for use with optional bolt-on PDSC)

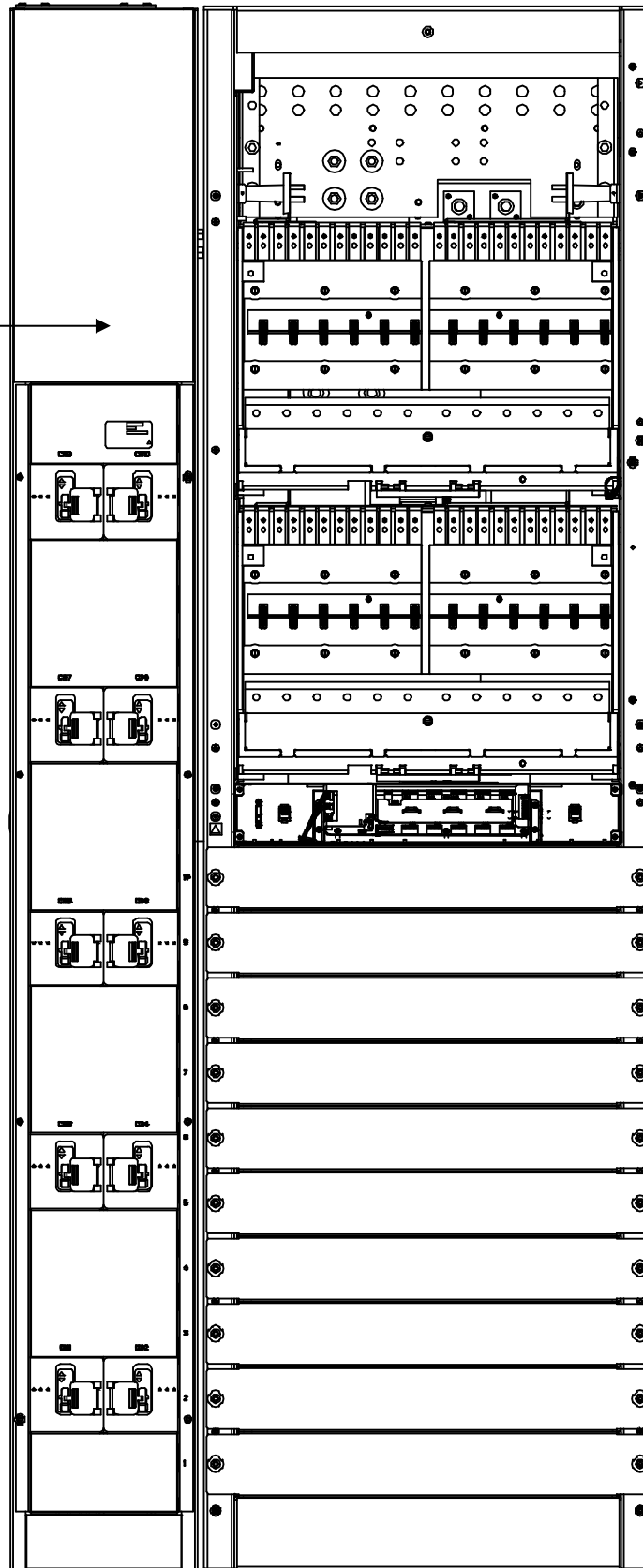

[List A](#): 480 VAC Plant Input

[List B](#): 208 VAC Plant Input

Distribution Bus (see [Distribution Devices](#) in [ACCESSORY DESCRIPTIONS](#) Section for distribution options)

Distribution Bus (see [Distribution Devices](#) in [ACCESSORY DESCRIPTIONS](#) Section for distribution options)

(see [Monitor/Control Diagram](#))

Door removed in illustration for clarity.

[P/N 486532603](#): Rectifier (480 VAC Input)

[P/N 486534003](#): Rectifier (208 VAC Input)

Front View

**582140000 Primary
Power Only Bay**

[List 103](#): Primary Power Only Bay (with Five [5] AC Feeds)

[List 104](#): Primary Power Only Bay (with Two [2] AC Feeds)

[List 105](#): Primary Power Only Bay (with Ten [10] AC Feeds)

[List 37](#): Surge Suppression Option for 480 VAC Input

[List 38](#): Surge Suppression Option for 208 VAC Input

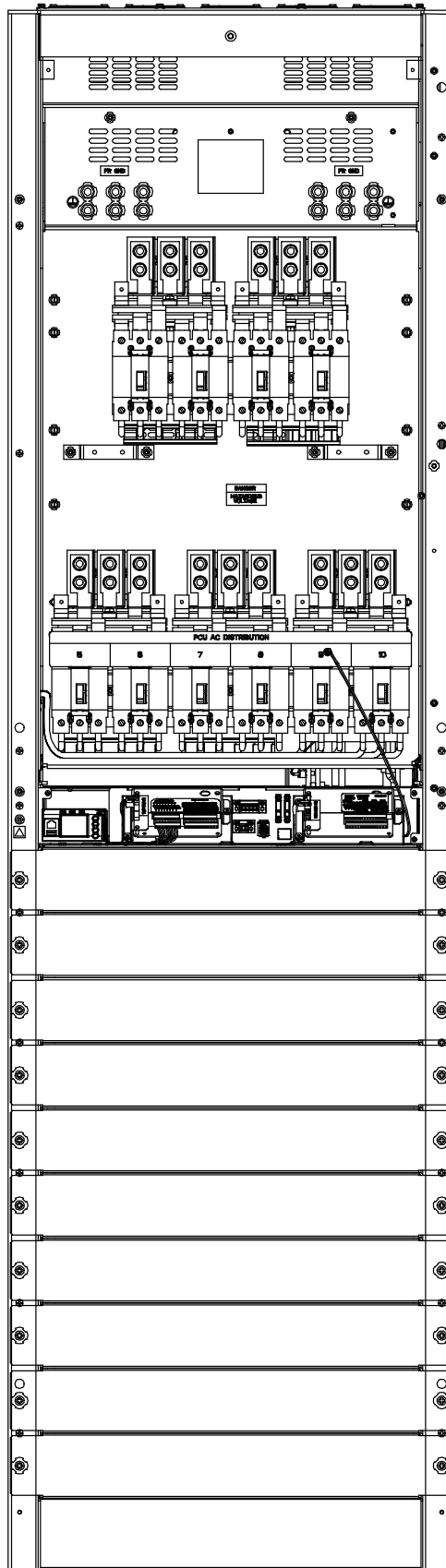

[List A](#): 480 VAC Plant Input

[List B](#): 208 VAC Plant Input

Door removed in illustration for clarity.

(see [Monitor/Control Diagram](#))

[P/N 486532603](#): Rectifier (480 VAC Input)

[P/N 486534003](#): Rectifier (208 VAC Input)

Front View

582140000 Secondary Power Only Bay

[List 113](#): Secondary Power Only Bay (with Five [5] AC Feeds)

[List 114](#): Secondary Power Only Bay (with Two [2] AC Feeds)

[List 115](#): Secondary Power Only Bay (with Ten [10] AC Feeds)

[List 37](#): Surge Suppression Option for 480 VAC Input

[List 38](#): Surge Suppression Option for 208 VAC Input

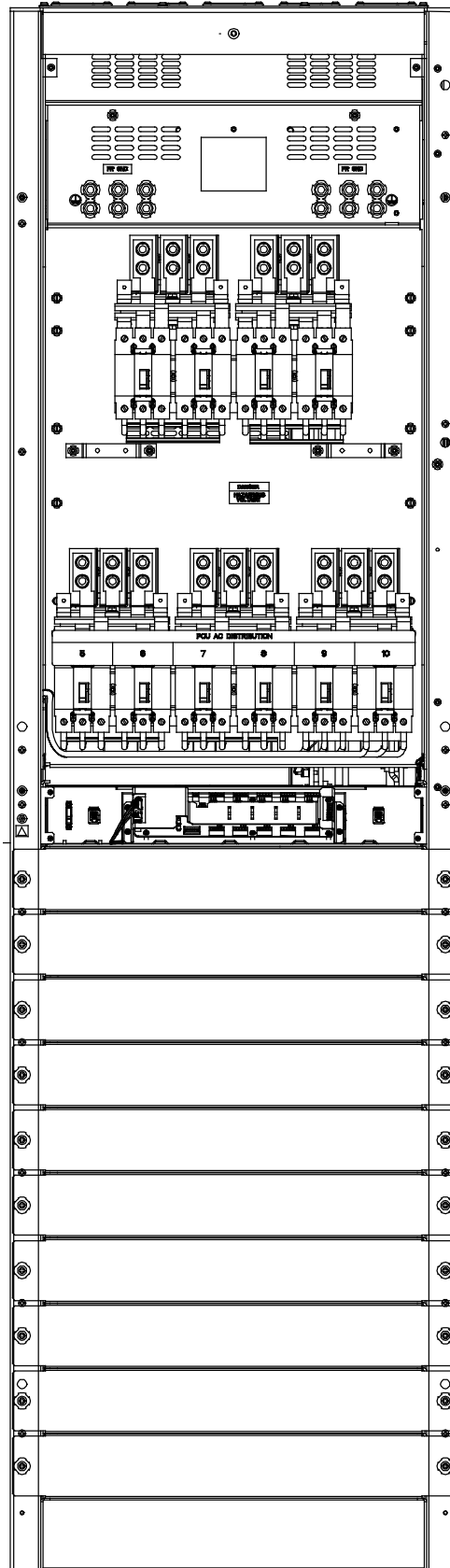

[List A](#): 480 VAC Plant Input

[List B](#): 208 VAC Plant Input

Door removed in illustration for clarity.

(see [Monitor/Control Diagram](#))

[P/N 486532603](#): Rectifier (480 VAC Input)

[P/N 486534003](#): Rectifier (208 VAC Input)

Front View

582140000
Distribution Only Bay

[List 116:](#) Distribution Only Bay
 (Cable Only Bay) Left or Right

[List 19:](#) Distribution Only Bay
 Expansion Busbars to Bridge
 PDSC

Distribution Bus
 (see [Distribution
 Devices](#) in
 ACCESSORY
 DESCRIPTIONS
 Section for
 distribution options)

(see [Monitor and Control
 Diagram](#))

Distribution Bus
 (see [Distribution
 Devices](#) in
 ACCESSORY
 DESCRIPTIONS
 Section for
 distribution options)

Blank Panel
 or
[List C:](#) Bullet Fuse/Circuit
 Breaker Panel

Distribution Bus
 (see [Distribution
 Devices](#) in
 ACCESSORY
 DESCRIPTIONS
 Section for
 distribution options)

Distribution Bus
 (see [Distribution
 Devices](#) in
 ACCESSORY
 DESCRIPTIONS
 Section for
 distribution options)

Front door removed in
 illustration for clarity.

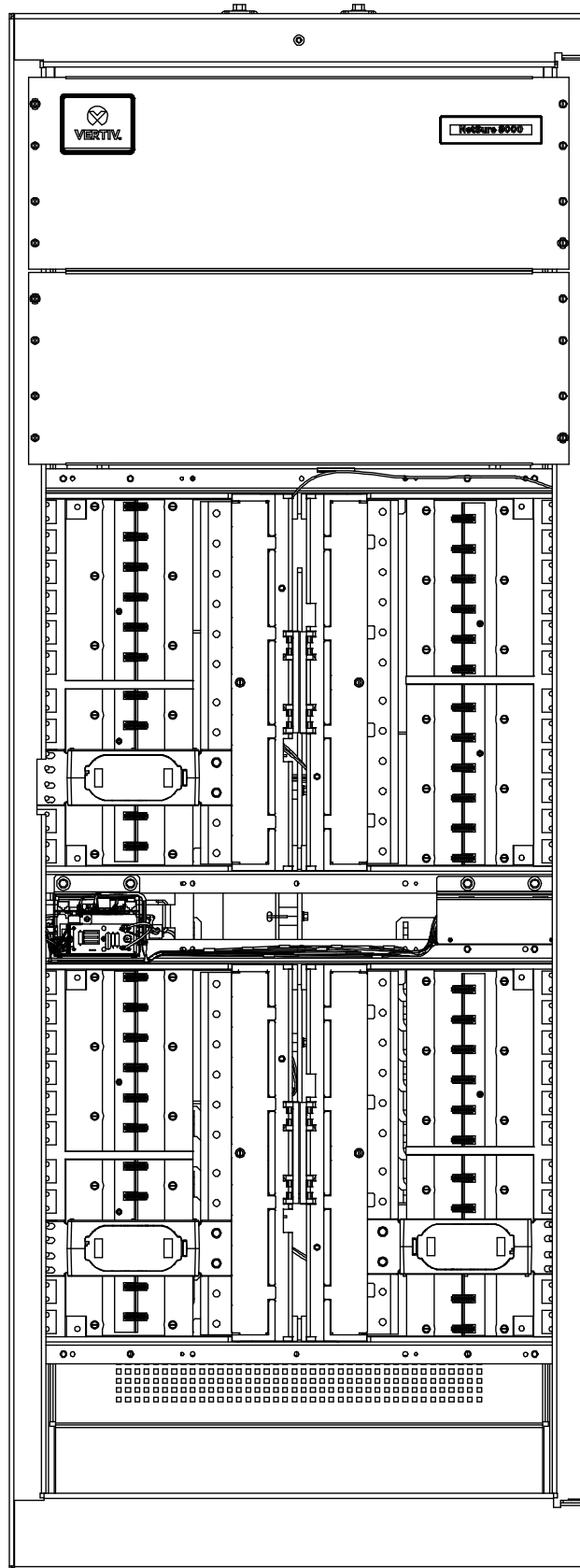

Front View

582140000
Distribution Only Bay

[List 117](#): 2nd Internal Bus
Distribution Only Bay - Expansion
to the Right or Left

[List 118](#): 1st Internal Bus
Distribution Only Bay - Expansion
to the Right

[List 19](#): Distribution Only Bay
Expansion Busbars to Bridge
PDSC

[List 122](#): 1st Internal Bus
Distribution Only Bay - Expansion
to the Left

(see [Monitor and Control Diagram](#))

Distribution Bus
(see [Distribution Devices](#) in
ACCESSORY DESCRIPTIONS
Section for
distribution options)

Distribution Bus
(see [Distribution Devices](#) in
ACCESSORY DESCRIPTIONS
Section for
distribution options)

Distribution Bus
(see [Distribution Devices](#) in
ACCESSORY DESCRIPTIONS
Section for
distribution options)

Distribution Bus
(see [Distribution Devices](#) in
ACCESSORY DESCRIPTIONS
Section for
distribution options)

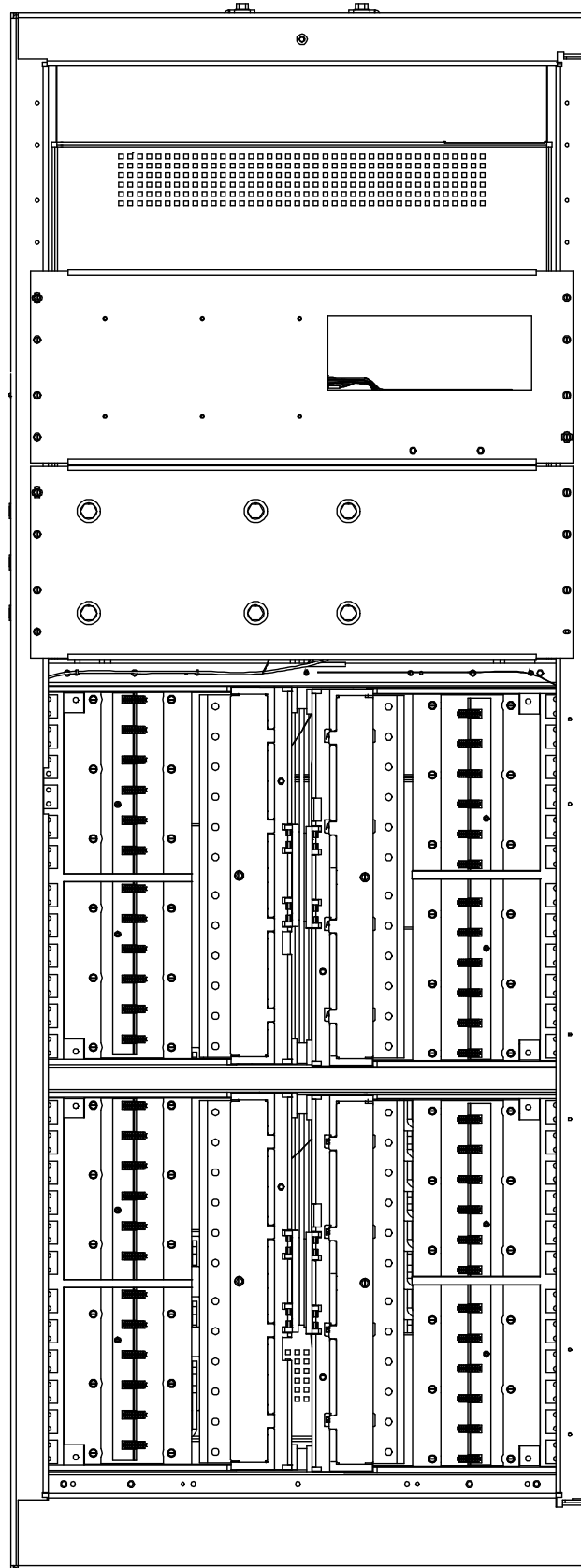

Front View

Front door removed in
illustration for clarity.

582140000

Primary and Secondary Power/Distribution and Power Only Bays Monitor/Control Diagram
(List 101, 102, 103, 104, 105, 111, 112, 113, 114, 115)

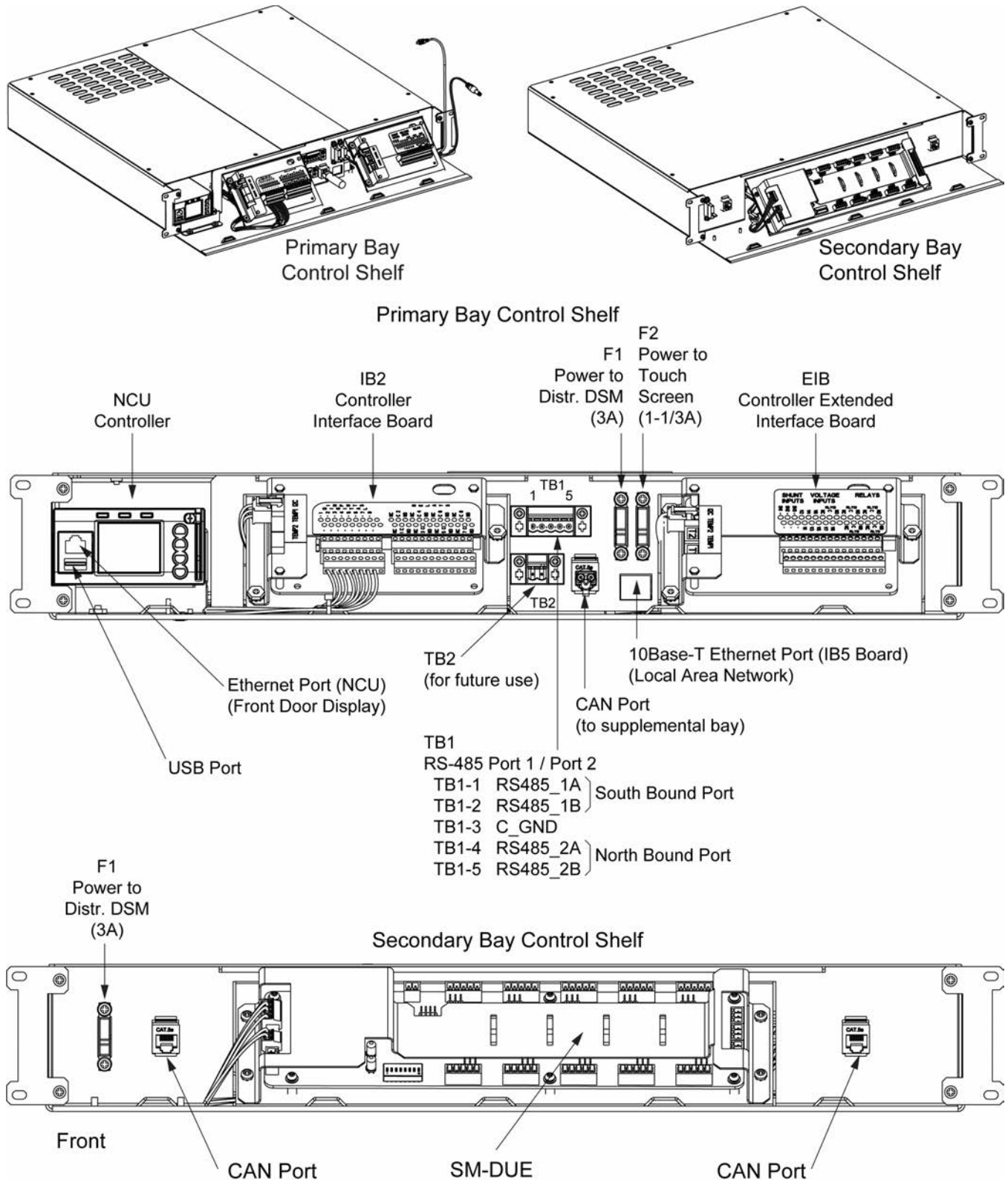

582140000
Distribution Only Bays Monitor and Control Diagram (List 116)

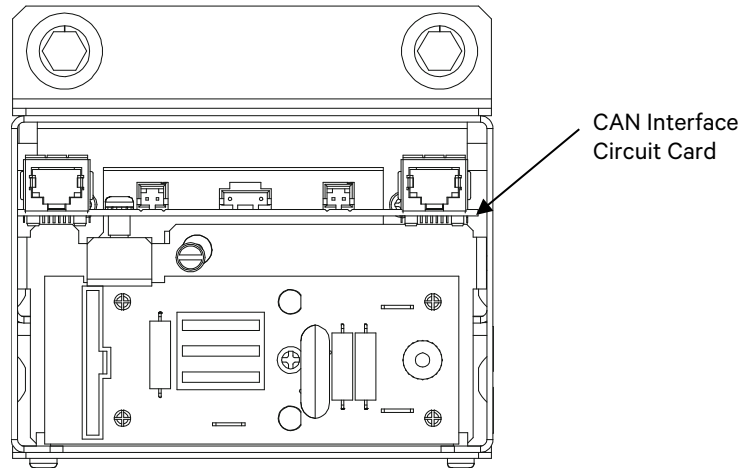

582140000
Distribution Only Bays Monitor and Control Diagram (List 117, 118, 122)

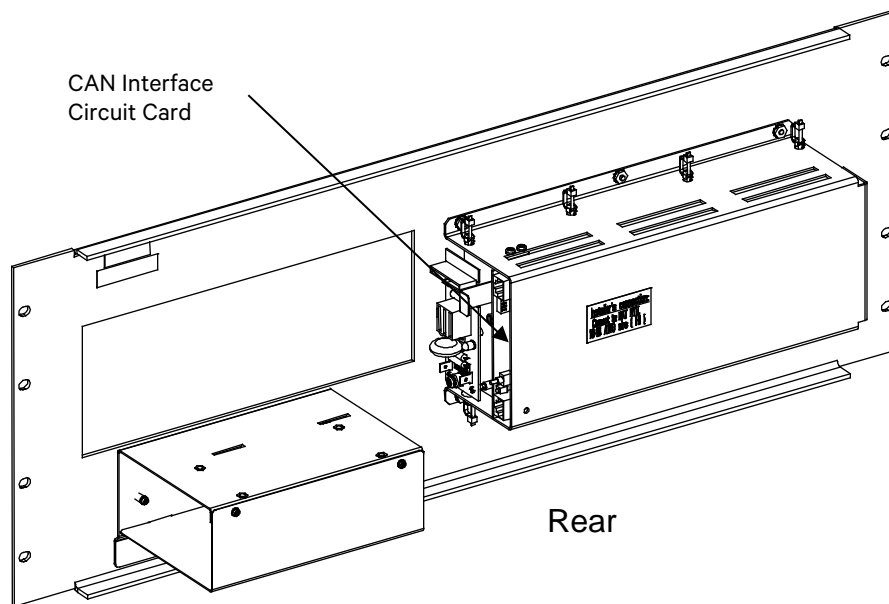

LIST DESCRIPTIONS

List Numbers

List A: 480 VAC Plant Input Voltage

Features

- ◆ Specifies 480 VAC plant input voltage.

List B: 208 VAC Plant Input Voltage

Features

- ◆ Specifies 208 VAC plant input voltage.

List 101: Primary Power/Distribution Bay (Common Equipment)

Features

- ◆ Provides common equipment for one (1) “power and distribution” bay rated for up to 2400 amperes.
- ◆ Mounted in a 93.5"H x 24"W x 30"D box framework.
- ◆ Provides ten (10) rectifier mounting positions.
- ◆ Provides an AC input termination panel that accepts ten (10) AC input branch circuits, one (1) per rectifier mounting position.
- ◆ Provides twenty four (24) distribution device mounting positions.
- ◆ Provides two (2) buses of distribution. Each bus contains a monitoring circuit card; which can be set for Group A designation or Group B designation.
- ◆ Configured for a 4000 A internal bus or external main battery termination bars.
- ◆ List 101: Equipped with an NCU controller and front panel touch screen PC for local access to the NCU webpages. Includes an IB5 board which provides a Network connection point for NCU remote access. Includes the IB2 NCU interface board (provides eight (8) programmable form C- relay outputs, eight (8) programmable binary inputs, and two (2) temperature inputs). Includes the EIB NCU extended interface board (provides five (5) programmable form-C relay outputs, two (2) temperature inputs, three (3) shunt inputs, and eight (8) battery midpoint inputs).
- ◆ Expandable either left or right.

Restrictions

The system must consist of one (1) primary power/distribution bay or primary power only bay and may consist of up to seven (7) additional bays. These additional bays may be a combination of secondary power/distribution bays, secondary power only bays, and/or distribution only bays (maximum of 4 distribution only bays per system).

Ordering Notes

- 1) Specify [List A](#) (480 VAC Input) or [List B](#) (208 VAC Input).
- 2) Order rectifiers as required per [P/N 486532603](#) (480 VAC Input) or [P/N 486534003](#) (208 VAC Input).
- 3) Order distribution fuse and/or circuit breaker devices as required per [Distribution Devices](#) in the *ACCESSORY DESCRIPTIONS* section.
- 4) List 101: Order temperature probes as required per [Temperature Probes](#) in the *ACCESSORY DESCRIPTIONS* section.
- 5) Order bay grounding lugs as required per [Power/Distribution Bay Frame Grounding Wire Sizes and Lugs](#) in the *ACCESSORY DESCRIPTIONS* section.
- 6) Order load distribution lugs as required per [Power/Distribution Bay and Distribution Only Bay Load Distribution Wire Sizes and Lugs](#) in the *ACCESSORY DESCRIPTIONS* section.
- 7) Order battery cable lugs as required per [Power/Distribution Bay Battery Cable Sizes and Lugs](#) in the *ACCESSORY DESCRIPTIONS* section.
- 8) Order AC input lugs as required per [Power/Distribution Bay AC Input, Ten \(10\) Rectifier Feeds Wire Sizes, Branch Circuit Protection, and Lugs](#) in the *ACCESSORY DESCRIPTIONS* section.
- 9) Order internal ground busbar assembly, external top-mount battery input busbar assembly, busbar shield kit, external top-mount ground (load return) busbar assembly, and/or load return lug extension busbar assembly as required per the appropriate sections located under [ACCESSORY DESCRIPTIONS](#).

List 102: Primary Power/Distribution Bay (Common Equipment)

Features

- ◆ Provides common equipment for one (1) “power and distribution” bay rated for up to 2400 amperes.
- ◆ Mounted in a 7'0"H x 24"W x 30"D Box Framework.
- ◆ Provides ten (10) rectifier mounting positions.
- ◆ Provides twenty four (24) distribution device mounting positions.
- ◆ Provides two (2) buses of distribution. Each bus contains a monitoring circuit card; which can be set for Group A designation or Group B designation.
- ◆ Configured for a 4000 A internal bus or external main battery termination bars.
- ◆ List 102: Equipped with an NCU controller and front panel touch screen PC for local access to the NCU webpages. Includes an IB5 board which provides a Network connection point for NCU remote access. Includes the IB2 NCU interface board (provides eight (8) programmable form C- relay outputs, eight (8) programmable binary inputs, and two (2) temperature inputs). Includes the EIB NCU extended interface board (provides five (5) programmable form-C relay outputs, two (2) temperature inputs, three (3) shunt inputs. and eight (8) battery midpoint inputs).
- ◆ Expandable either left or right.
- ◆ Surge suppression optional.

Restrictions

The system must consist of one (1) primary power/distribution bay or primary power only bay and may consist of up to seven (7) additional bays. These additional bays may be a combination of secondary power/distribution bays, secondary power only bays, and/or distribution only bays (maximum of 4 distribution only bays per system).

Requires [List 130](#) (480 VAC Input), [List 131](#) (480 VAC Input), or [List 132](#) (208 VAC Input) Bolt-On PDSC (AC Input 'Power Distribution Service Cabinet').

Ordering Notes

- 1) Specify [List A](#) (480 VAC Input) or [List B](#) (208 VAC Input).
- 2) Order Bolt-On PDSC (AC Input 'Power Distribution Service Cabinet') per [List 130](#) (480 VAC Input), [List 131](#) (480 VAC Input), or [List 132](#) (208 VAC Input).
- 3) Order rectifiers as required per [P/N 486532603](#) (480 VAC Input) or [P/N 486534003](#) (208 VAC Input).
- 4) Order distribution fuse and/or circuit breaker devices as required per [Distribution Devices](#) in the *ACCESSORY DESCRIPTIONS* section.
- 5) List 102: Order temperature probes as required per [Temperature Probes](#) in the *ACCESSORY DESCRIPTIONS* section.
- 6) Order bay grounding lugs as required per [Power/Distribution Bay Frame Grounding Wire Sizes and Lugs](#) in the *ACCESSORY DESCRIPTIONS* section.
- 7) Order load distribution lugs as required per [Power/Distribution Bay and Distribution Only Bay Load Distribution Wire Sizes and Lugs](#) in the *ACCESSORY DESCRIPTIONS* section.
- 8) Order battery cable lugs as required per [Power/Distribution Bay Battery Cable Sizes and Lugs](#) in the *ACCESSORY DESCRIPTIONS* section.
- 9) Order AC input lugs as required per [Power/Distribution Bay AC Input, Two \(2\) Rectifier Feeds Wire Sizes, Branch Circuit Protection, and Lugs](#) or [Power/Distribution Bay AC Input, One \(1\) Rectifier Feed Wire Sizes, Branch Circuit Protection, and Lugs](#) in the *ACCESSORY DESCRIPTIONS* section.
- 10) Order internal ground busbar assembly, external top-mount battery input busbar assembly, busbar shield kit, external top-mount ground (load return) busbar assembly, and/or load return lug extension busbar assembly as required per the appropriate sections located under [ACCESSORY DESCRIPTIONS](#).

List 103: Primary Power Only Bay, Five (5) AC Feeds (Common Equipment)

Features

- ◆ Provides common equipment for one (1) power only bay rated for up to 2200 amperes.
- ◆ Mounted in a 7'0"H x 24"W x 30"D box framework.
- ◆ Provides ten (10) rectifier mounting positions.
- ◆ Provides AC input circuit breakers rated for 22kA interrupting capacity for each rectifier position. Circuit breakers are pad-lockable.

Vertiv™ NetSure™ 8200 -48 VDC Power System

System Application Guide

- ◆ In ferro replacement applications, will accommodate five (5) AC inputs sized for 400A ferro rectifiers (208V, 100A or 480V, 50A).
- ◆ List 103: Equipped with an NCU controller and front panel touch screen PC for local access to the NCU webpages. Includes an IB5 board which provides a Network connection point for NCU remote access. Includes the IB2 NCU interface board (provides eight (8) programmable form C- relay outputs, eight (8) programmable binary inputs, and two (2) temperature inputs). Includes the EIB NCU extended interface board (provides five (5) programmable form-C relay outputs, two (2) temperature inputs, three (3) shunt inputs. and eight (8) battery midpoint inputs).
- ◆ Expandable either left or right, cable connected.

Restrictions

The system must consist of one (1) primary power/distribution bay or primary power only bay and may consist of up to seven (7) additional bays. These additional bays may be a combination of secondary power/distribution bays, secondary power only bays, and/or distribution only bays (maximum of 4 distribution only bays per system).

Requires external main battery termination bars.

Ordering Notes

- 1) Specify [List A](#) (480 VAC Input) or [List B](#) (208 VAC Input).
- 2) If List A specified, bay will include ten (10) P/N 256933200 30 A circuit breakers.
- 3) If List B specified, bay will include ten (10) P/N 256937200 60 A circuit breakers.
- 4) Order rectifiers as required per [P/N 486532603](#) (480 VAC Input) or [P/N 486534003](#) (208 VAC Input).
- 5) List 103: Order temperature probes as required per [Temperature Probes](#) in the *ACCESSORY DESCRIPTIONS* section.
- 6) Order bay grounding lugs as required per [Power Only Bay Frame Grounding Wire Sizes and Lugs](#) in the *ACCESSORY DESCRIPTIONS* section.
- 7) Order DC output cable lugs as required per [Power Only Bay DC Output Cable Sizes and Lugs](#) in the *ACCESSORY DESCRIPTIONS* section.
- 8) Order AC input lugs as required per [Power Only Bay AC Input, Five \(5\) Rectifier Feeds Wire Sizes, Branch Circuit Protection, and Lugs](#) in the *ACCESSORY DESCRIPTIONS* section.
- 9) Order external top-mount battery input busbar assembly, busbar shield kit, external top-mount ground (load return) busbar assembly, and/or load return lug extension busbar assembly as required per the appropriate sections located under [ACCESSORY DESCRIPTIONS](#).

List 104: Primary Power Only Bay, Two (2) AC Feeds (Common Equipment)

Features

- ◆ Provides common equipment for one (1) power only bay rated for up to 2200 amperes.
- ◆ Mounted in a 7'0"H x 24"W x 30"D box framework.
- ◆ Provides ten (10) rectifier mounting positions.
- ◆ Provides AC input circuit breakers rated for 22kA interrupting capacity for each rectifier position. Circuit breakers are pad-lockable.
- ◆ List 104: Equipped with an NCU controller and front panel touch screen PC for local access to the NCU webpages. Includes an IB5 board which provides a Network connection point for NCU remote access. Includes the IB2 NCU interface board (provides eight (8) programmable form C- relay outputs, eight (8) programmable binary inputs, and two (2) temperature inputs). Includes the EIB NCU extended interface board (provides five (5) programmable form-C relay outputs, two (2) temperature inputs, three (3) shunt inputs. and eight (8) battery midpoint inputs).
- ◆ Expandable either left or right, cable connected.
- ◆ Surge suppression optional.

Restrictions

The system must consist of one (1) primary power/distribution bay or primary power only bay and may consist of up to seven (7) additional bays. These additional bays may be a combination of secondary power/distribution bays, secondary power only bays, and/or distribution only bays (maximum of 4 distribution only bays per system).

Requires external main battery termination bars.

Ordering Notes

- 1) Specify [List A](#) (480 VAC Input) or [List B](#) (208 VAC Input).
- 2) If List A specified, bay will include ten (10) P/N 256933200 30 A circuit breakers.

Vertiv™ NetSure™ 8200 -48 VDC Power System

System Application Guide

- 3) If List B specified, bay will include ten (10) P/N 256937200 60 A circuit breakers.
- 4) Order optional surge suppressors per [List 37](#) or [List 38](#).
- 5) Order rectifiers as required per [P/N 486532603](#) (480 VAC Input) or [P/N 486534003](#) (208 VAC Input).
- 6) List 104: Order temperature probes as required per [Temperature Probes](#) in the *ACCESSORY DESCRIPTIONS* section.
- 7) Order bay grounding lugs as required per [Power Only Bay Frame Grounding Wire Sizes and Lugs](#) in the *ACCESSORY DESCRIPTIONS* section.
- 8) Order DC output cable lugs as required per [Power Only Bay DC Output Cable Sizes and Lugs](#) in the *ACCESSORY DESCRIPTIONS* section.
- 9) Order AC input lugs as required per [Power Only Bay AC Input, Two \(2\) Rectifier Feeds Wire Sizes, Branch Circuit Protection, and Lugs](#) in the *ACCESSORY DESCRIPTIONS* section.
- 10) Order external top-mount battery input busbar assembly, busbar shield kit, external top-mount ground (load return) busbar assembly, and/or load return lug extension busbar assembly as required per the appropriate sections located under [ACCESSORY DESCRIPTIONS](#).

List 105: Primary Power Only Bay, Ten (10) AC Feeds (Common Equipment)

Features

- ◆ Provides common equipment for one (1) power only bay rated for up to 2200 amperes.
- ◆ Mounted in a 7'0"H x 24"W x 30"D box framework.
- ◆ Provides ten (10) rectifier mounting positions.
- ◆ In ferro replacement applications, will accommodate ten (10) AC inputs sized for 200 A ferro rectifiers (208 V, 60 A or 480 V, 25 A).
- ◆ List 105: Equipped with an NCU controller and front panel touch screen PC for local access to the NCU webpages. Includes an IB5 board which provides a Network connection point for NCU remote access. Includes the IB2 NCU interface board (provides eight (8) programmable form C- relay outputs, eight (8) programmable binary inputs, and two (2) temperature inputs). Includes the EIB NCU extended interface board (provides five (5) programmable form-C relay outputs, two (2) temperature inputs, three (3) shunt inputs. and eight (8) battery midpoint inputs).
- ◆ Expandable either left or right, cable connected.

Restrictions

The system must consist of one (1) primary power/distribution bay or primary power only bay and may consist of up to seven (7) additional bays. These additional bays may be a combination of secondary power/distribution bays, secondary power only bays, and/or distribution only bays (maximum of 4 distribution only bays per system).

Requires external main battery termination bars.

Ordering Notes

- 1) Specify [List A](#) (480 VAC Input) or [List B](#) (208 VAC Input).
- 2) Order rectifiers as required per [P/N 486532603](#) (480 VAC Input) or [P/N 486534003](#) (208 VAC Input).
- 3) List 105: Order temperature probes as required per [Temperature Probes](#) in the *ACCESSORY DESCRIPTIONS* section.
- 4) Order bay grounding lugs as required per [Power Only Bay Frame Grounding Wire Sizes and Lugs](#) in the *ACCESSORY DESCRIPTIONS* section.
- 5) Order DC output cable lugs as required per [Power Only Bay DC Output Cable Sizes and Lugs](#) in the *ACCESSORY DESCRIPTIONS* section.
- 6) Order AC input lugs as required per [Power Only Bay AC Input, Ten \(10\) Rectifier Feed Wire Sizes, Branch Circuit Protection, and Lugs](#) in the *ACCESSORY DESCRIPTIONS* section.
- 7) Order external top-mount battery input busbar assembly, busbar shield kit, external top-mount ground (load return) busbar assembly, and/or load return lug extension busbar assembly as required per the appropriate sections located under [ACCESSORY DESCRIPTIONS](#).

List 111: Secondary Power/Distribution Bay (Common Equipment)

Features

- ◆ Provides common equipment for one (1) "power and distribution" bay rated for up to 2400 amperes.
- ◆ Mounted in a 93.5"H x 24"W x 30"D box framework.

Vertiv™ NetSure™ 8200 -48 VDC Power System

System Application Guide

- ◆ Provides ten (10) rectifier mounting positions.
- ◆ Provides an AC input termination panel that accepts ten (10) AC input branch circuits, one (1) per rectifier mounting position.
- ◆ Provides twenty four (24) distribution device mounting positions.
- ◆ Provides two (2) buses of distribution. Each bus contains a monitoring circuit card; which can be set for Group A designation or Group B designation.
- ◆ Configured for a 4000 A internal bus or external main battery termination bars.
- ◆ Includes a router or CAN interface assembly for bay communication to the controller/monitor in the primary power bay.
- ◆ List 111: Includes the SM-DUE. Refer to “**SM-DUE (if furnished)**” on page 2.
- ◆ Network bay interconnect cables provided (Qty. 1 P/N 514642, Qty. 1 P/N 514639).
- ◆ Expandable either left or right.

Restrictions

The system must consist of one (1) primary power/distribution bay or primary power only bay and may consist of up to seven (7) additional bays. These additional bays may be a combination of secondary power/distribution bays, secondary power only bays, and/or distribution only bays (maximum of 4 distribution only bays per system).

Ordering Notes

- 1) Specify [List A](#) (480 VAC Input) or [List B](#) (208 VAC Input).
- 2) Order rectifiers as required per [P/N 486532603](#) (480 VAC Input) or [P/N 486534003](#) (208 VAC Input).
- 3) Order distribution fuse and/or circuit breaker devices as required per [Distribution Devices](#) in the ACCESSORY DESCRIPTIONS section.
- 4) Order bay grounding lugs as required per [Power/Distribution Bay Frame Grounding Wire Sizes and Lugs](#) in the ACCESSORY DESCRIPTIONS section.
- 5) Order load distribution lugs as required per [Power/Distribution Bay and Distribution Only Bay Load Distribution Wire Sizes and Lugs](#) in the ACCESSORY DESCRIPTIONS section.
- 6) Order battery cable lugs as required per [Power/Distribution Bay Battery Cable Sizes and Lugs](#) in the ACCESSORY DESCRIPTIONS section.
- 7) Order AC input lugs as required per [Power/Distribution Bay AC Input, Ten \(10\) Rectifier Feeds Wire Sizes, Branch Circuit Protection, and Lugs](#) in the ACCESSORY DESCRIPTIONS section.
- 8) Order internal ground busbar assembly, external top-mount battery input busbar assembly, busbar shield kit, external top-mount ground (load return) busbar assembly, and/or load return lug extension busbar assembly as required per the appropriate sections located under [ACCESSORY DESCRIPTIONS](#).
- 9) If secondary bays are placed on both sides of the primary bay, a different length Network cable is required that connects a secondary bay on one side with a secondary bay on the other side. Order per [Replacement/Additional Network Cables](#).
- 10) Side cover panels are provided with primary bays. These cover panels are used with secondary bays when bays are placed next to each other. In installations where a secondary bay is placed by itself, order (1) of each of the following side cover panels per exposed side: P/N 514482 and P/N 514484.

List 112: Secondary Power/Distribution Bay (Common Equipment)

Features

- ◆ Provides common equipment for one (1) “power and distribution” bay rated for up to 2400 amperes.
- ◆ Mounted in a 7'0"H x 24"W x 30"D box framework.
- ◆ Provides ten (10) rectifier mounting positions.
- ◆ Provides twenty four (24) distribution device mounting positions.
- ◆ Provides two (2) buses of distribution. Each bus contains a monitoring circuit card; which can be set for Group A designation or Group B designation.
- ◆ Configured for a 4000 A internal bus or external main battery termination bars.
- ◆ Includes a router or CAN interface assembly for bay communication to the controller/monitor in the primary power bay.
- ◆ List 112: Includes the SM-DUE. Refer to “**SM-DUE (if furnished)**” on page 2.
- ◆ Network bay interconnect cables provided (Qty. 1 P/N 514643, Qty. 1 P/N 509900).

Vertiv™ NetSure™ 8200 -48 VDC Power System

System Application Guide

- ◆ Expandable either left or right.
- ◆ Surge suppression optional.

Restrictions

Requires [List 130](#) (480 VAC Input), [List 131](#) (480 VAC Input), or [List 132](#) (208 VAC Input) Bolt-On PDSC (AC Input 'Power Distribution Service Cabinet').

The system must consist of one (1) primary power/distribution bay or primary power only bay and may consist of up to seven (7) additional bays. These additional bays may be a combination of secondary power/distribution bays, secondary power only bays, and/or distribution only bays (maximum of 4 distribution only bays per system).

Ordering Notes

- 1) Specify [List A](#) (480 VAC Input) or [List B](#) (208 VAC Input).
- 2) Order Bolt-On PDSC (AC Input 'Power Distribution Service Cabinet') per [List 130](#) (480 VAC Input), [List 131](#) (480 VAC Input), or [List 132](#) (208 VAC Input).
- 3) Order rectifiers as required per [P/N 486532603](#) (480 VAC Input) or [P/N 486534003](#) (208 VAC Input).
- 4) Order distribution fuse and/or circuit breaker devices as required per [Distribution Devices](#) in the ACCESSORY DESCRIPTIONS section.
- 5) Order bay grounding lugs as required per [Power/Distribution Bay Frame Grounding Wire Sizes and Lugs](#) in the ACCESSORY DESCRIPTIONS section.
- 6) Order load distribution lugs as required per [Power/Distribution Bay and Distribution Only Bay Load Distribution Wire Sizes and Lugs](#) in the ACCESSORY DESCRIPTIONS section.
- 7) Order battery cable lugs as required per [Power/Distribution Bay Battery Cable Sizes and Lugs](#) in the ACCESSORY DESCRIPTIONS section.
- 8) Order AC input lugs as required per [Power/Distribution Bay AC Input, Two \(2\) Rectifier Feeds Wire Sizes, Branch Circuit Protection, and Lugs](#) or [Power/Distribution Bay AC Input, One \(1\) Rectifier Feed Wire Sizes, Branch Circuit Protection, and Lugs](#) in the ACCESSORY DESCRIPTIONS section.
- 9) Order internal ground busbar assembly, external top-mount battery input busbar assembly, busbar shield kit, external top-mount ground (load return) busbar assembly, and/or load return lug extension busbar assembly as required per the appropriate sections located under [ACCESSORY DESCRIPTIONS](#).
- 10) If secondary bays are placed on both sides of the primary bay, a different length Network cable is required that connects a secondary bay on one side with a secondary bay on the other side. Order per [Replacement/Additional Network Cables](#).
- 11) Side cover panels are provided with primary bays. These cover panels are used with secondary bays when bays are placed next to each other. In installations where a secondary bay is placed by itself, order (1) of each of the following side cover panels per exposed side: P/N 514482 and P/N 514484.

List 113: Secondary Power Only Bay, Five (5) AC Feeds (Common Equipment)

Features

- ◆ Provides common equipment for one (1) power only bay rated for up to 2200 amperes.
- ◆ Mounted in a 7'0"H x 24"W x 30"D box framework.
- ◆ Provides ten (10) rectifier mounting positions.
- ◆ Provides AC input circuit breakers rated for 22kA interrupting capacity for each rectifier position. Circuit breakers are pad-lockable.
- ◆ In ferro replacement applications, will accommodate five (5) AC inputs sized for 400 A ferro rectifiers (208 V, 100 A or 480 V, 50 A).
- ◆ Includes a router or CAN interface assembly for bay communication to the controller/monitor in the primary power bay.
- ◆ List 113: Includes the SM-DUE. Refer to "**SM-DUE (if furnished)**" on page 2.
- ◆ Network bay interconnect cables provided (Qty. 1 P/N 514643, Qty. 1 P/N 509900).
- ◆ Expandable either left or right, cable connected.

Restrictions

The system must consist of one (1) primary power/distribution bay or primary power only bay and may consist of up to seven (7) additional bays. These additional bays may be a combination of secondary power/distribution bays, secondary power only bays, and/or distribution only bays (maximum of 4 distribution only bays per system).

Requires external main battery termination bars.

Vertiv™ NetSure™ 8200 -48 VDC Power System

System Application Guide

Ordering Notes

- 1) Specify [List A](#) (480 VAC Input) or [List B](#) (208 VAC Input).
- 2) If List A specified, bay will include ten (10) P/N 256933200 30 A circuit breakers.
- 3) If List B specified, bay will include ten (10) P/N 256937200 60 A circuit breakers.
- 4) Order rectifiers as required per [P/N 486532603](#) (480 VAC Input) or [P/N 486534003](#) (208 VAC Input).
- 5) Order bay grounding lugs as required per [Power Only Bay Frame Grounding Wire Sizes and Lugs](#) in the ACCESSORY DESCRIPTIONS section.
- 6) Order DC output cable lugs as required per [Power Only Bay DC Output Cable Sizes and Lugs](#) in the ACCESSORY DESCRIPTIONS section.
- 7) Order AC input lugs as required per [Power Only Bay AC Input, Five \(5\) Rectifier Feeds Wire Sizes, Branch Circuit Protection, and Lugs](#) in the ACCESSORY DESCRIPTIONS section.
- 8) Order external top-mount battery input busbar assembly, busbar shield kit, external top-mount ground (load return) busbar assembly, and/or load return lug extension busbar assembly as required per the appropriate sections located under [ACCESSORY DESCRIPTIONS](#).
- 9) If secondary bays are placed on both sides of the primary bay, a different length Network cable is required that connects a secondary bay on one side with a secondary bay on the other side. Order per [Replacement/Additional Network Cables](#).
- 10) Side cover panels are provided with primary bays. These cover panels are used with secondary bays when bays are placed next to each other. In installations where a secondary bay is placed by itself, order (1) of each of the following side cover panels per exposed side: P/N 514482 and P/N 514484.

List 114: Secondary Power Only Bay, Two (2) AC Feeds (Common Equipment)

Features

- ◆ Provides common equipment for one (1) power only bay rated for up to 2200 amperes.
- ◆ Mounted in a 7'0"H x 24"W x 30"D box framework.
- ◆ Provides ten (10) rectifier mounting positions.
- ◆ Provides AC input circuit breakers rated for 22kA interrupting capacity for each rectifier position. Circuit breakers are pad-lockable.
- ◆ Includes a router or CAN interface assembly for bay communication to the controller/monitor in the primary power bay.
- ◆ List 114: Includes the SM-DUE. Refer to "**SM-DUE (if furnished)**" on page 2.
- ◆ Network bay interconnect cables provided (Qty. 1 P/N 514643, Qty. 1 P/N 509900).
- ◆ Expandable either left or right, cable connected.
- ◆ Surge suppression optional.

Restrictions

The system must consist of one (1) primary power/distribution bay or primary power only bay and may consist of up to seven (7) additional bays. These additional bays may be a combination of secondary power/distribution bays, secondary power only bays, and/or distribution only bays (maximum of 4 distribution only bays per system).

Requires external main battery termination bars.

Ordering Notes

- 1) Specify [List A](#) (480 VAC Input) or [List B](#) (208 VAC Input).
- 2) If List A specified, bay will include ten (10) P/N 256933200 30 A circuit breakers.
- 3) If List B specified, bay will include ten (10) P/N 256937200 60 A circuit breakers.
- 4) Order optional surge suppressors per [List 37](#) or [List 38](#).
- 5) Order rectifiers as required per [P/N 486532603](#) (480 VAC Input) or [P/N 486534003](#) (208 VAC Input).
- 6) Order bay grounding lugs as required per [Power Only Bay Frame Grounding Wire Sizes and Lugs](#) in the ACCESSORY DESCRIPTIONS section.
- 7) Order DC output cable lugs as required per [Power Only Bay DC Output Cable Sizes and Lugs](#) in the ACCESSORY DESCRIPTIONS section.
- 8) Order AC input lugs as required per [Power Only Bay AC Input, Two \(2\) Rectifier Feeds Wire Sizes, Branch Circuit Protection, and Lugs](#) in the ACCESSORY DESCRIPTIONS section.

Vertiv™ NetSure™ 8200 -48 VDC Power System

System Application Guide

- 9) Order external top-mount battery input busbar assembly, busbar shield kit, external top-mount ground (load return) busbar assembly, and/or load return lug extension busbar assembly as required per the appropriate sections located under [ACCESSORY DESCRIPTIONS](#).
- 10) If secondary bays are placed on both sides of the primary bay, a different length Network cable is required that connects a secondary bay on one side with a secondary bay on the other side. Order per [Replacement/Additional Network Cables](#).
- 11) Side cover panels are provided with primary bays. These cover panels are used with secondary bays when bays are placed next to each other. In installations where a secondary bay is placed by itself, order (1) of each of the following side cover panels per exposed side: P/N 514482 and P/N 514484.

List 115: Secondary Power Only Bay, Ten (10) AC Feeds (Common Equipment)

Features

- ◆ Provides common equipment for one (1) power only bay rated for up to 2200 amperes.
- ◆ Mounted in a 7'0"H x 24"W x 30"D box framework.
- ◆ Provides ten (10) rectifier mounting positions.
- ◆ In ferro replacement applications, will accommodate ten (10) AC inputs sized for 200 A ferro rectifiers (208 V, 60 A or 480 V, 25 A).
- ◆ Includes a router or CAN interface assembly for bay communication to the controller/monitor in the primary power bay.
- ◆ List 115: Includes the SM-DUE. Refer to "**SM-DUE (if furnished)**" on page 2.
- ◆ Network bay interconnect cables provided (Qty. 1 P/N 514643, Qty. 1 P/N 509900).
- ◆ Expandable either left or right, cable connected.

Restrictions

The system must consist of one (1) primary power/distribution bay or primary power only bay and may consist of up to seven (7) additional bays. These additional bays may be a combination of secondary power/distribution bays, secondary power only bays, and/or distribution only bays (maximum of 4 distribution only bays per system).

Requires external main battery termination bars.

Ordering Notes

- 1) Specify [List A](#) (480 VAC Input) or [List B](#) (208 VAC Input).
- 2) Order rectifiers as required per [P/N 486532603](#) (480 VAC Input) or [P/N 486534003](#) (208 VAC Input).
- 3) Order bay grounding lugs as required per [Power Only Bay Frame Grounding Wire Sizes and Lugs](#) in the *ACCESSORY DESCRIPTIONS* section.
- 4) Order DC output cable lugs as required per [Power Only Bay DC Output Cable Sizes and Lugs](#) in the *ACCESSORY DESCRIPTIONS* section.
- 5) Order AC input lugs as required per [Power Only Bay AC Input, Ten \(10\) Rectifier Feed Wire Sizes, Branch Circuit Protection, and Lugs](#) in the *ACCESSORY DESCRIPTIONS* section.
- 6) Order external top-mount battery input busbar assembly, busbar shield kit, external top-mount ground (load return) busbar assembly, and/or load return lug extension busbar assembly as required per the appropriate sections located under [ACCESSORY DESCRIPTIONS](#).
- 7) If secondary bays are placed on both sides of the primary bay, a different length Network cable is required that connects a secondary bay on one side with a secondary bay on the other side. Order per [Replacement/Additional Network Cables](#).
- 8) Side cover panels are provided with primary bays. These cover panels are used with secondary bays when bays are placed next to each other. In installations where a secondary bay is placed by itself, order (1) of each of the following side cover panels per exposed side: P/N 514482 and P/N 514484.

List 116: Distribution Only Bay (Cable Only Bay) Left or Right

Features

- ◆ For use with cable to overhead bus external term bars (left or right).
- ◆ Provides common equipment for one (1) distribution only bay rated for up to 6000 amperes.
- ◆ Mounted in a 7'0"H x 31.375"W x 30"D seismic rated (Zone 4) box framework.
- ◆ Provides forty-eight (48) distribution device mounting positions.

Vertiv™ NetSure™ 8200 -48 VDC Power System

System Application Guide

- ◆ Provides four (4) buses of distribution. Each bus contains a monitoring circuit card; which can be set for Group A designation or Group B designation.
- ◆ Includes a router or CAN interface assembly for bay communication to the controller/monitor in the primary power bay.
- ◆ Network bay interconnect cable provided (P/N 514643 and P/N 514644).

Restrictions

The system must consist of one (1) primary power/distribution bay or primary power only bay and may consist of up to seven (7) additional bays. These additional bays may be a combination of secondary power/distribution bays, secondary power only bays, and/or distribution only bays (maximum of 4 distribution only bays per system).

Requires external main battery termination bars.

Ordering Notes

- 1) Order distribution fuse and/or circuit breaker devices as required per [Distribution Devices](#) in the ACCESSORY DESCRIPTIONS section.
- 2) Order bay grounding lugs as required per [Distribution Only Bay Frame Grounding Wire Sizes and Lugs Selection](#) in the ACCESSORY DESCRIPTIONS section.
- 3) Order load distribution lugs as required per [Power/Distribution Bay and Distribution Only Bay Load Distribution Wire Sizes and Lugs](#) in the ACCESSORY DESCRIPTIONS section.
- 4) Order DC input cable lugs as required per [Distribution Only Bay DC Input Cable Sizes and Lugs Selection](#) in the ACCESSORY DESCRIPTIONS section.
- 5) Order one (1) "Twenty-Four (24) Position Bullet-Nose Circuit Breaker/Fuse Panel" per distribution bay as required per [List C](#).
- 6) If a different length Network cable is required, order per [Replacement/Additional Network Cables](#).
- 7) Side cover panels are factory installed on one side of the bay. In installations where a distribution only bay is placed by itself, order (2) P/N 528633 side cover panels for the other side.

List 117: 2nd Internal Bus Distribution Only Bay – Expansion to the Right or Left

Features

- ◆ Provides common equipment for one (1) "distribution only" bay rated for up to 6000 amperes.
- ◆ Mounted in a 7'0"H x 31.375"W x 30"D seismic rated (Zone 4) box framework.
- ◆ Provides forty-eight (48) distribution device mounting positions.
- ◆ Provides four (4) buses of distribution. Each bus contains a monitoring circuit card; which can be set for Group A designation or Group B designation.
- ◆ Includes a router or CAN interface assembly for bay communication to the controller/monitor in the primary power bay.
- ◆ Network bay interconnect cable provided (P/N 514643).

Restrictions

The system must consist of one (1) primary power/distribution bay or primary power only bay and may consist of up to seven (7) additional bays. These additional bays may be a combination of secondary power/distribution bays, secondary power only bays, and/or distribution only bays (maximum of 4 distribution only bays per system).

Must be installed to the left or right of a distribution only bay.

Cannot be installed 'in-between' power/distribution bays.

Ordering Notes

- 1) Order distribution fuse and/or circuit breaker devices as required per [Distribution Devices](#) in the ACCESSORY DESCRIPTIONS section.
- 2) Order bay grounding lugs as required per [Distribution Only Bay Frame Grounding Wire Sizes and Lugs Selection](#) in the ACCESSORY DESCRIPTIONS section.
- 3) Order load distribution lugs as required per [Power/Distribution Bay and Distribution Only Bay Load Distribution Wire Sizes and Lugs](#) in the ACCESSORY DESCRIPTIONS section.
- 4) Order one (1) "Twenty-Four (24) Position Bullet-Nose Circuit Breaker/Fuse Panel" per distribution bay as required per [List C](#).
- 5) Side cover panels are provided with the 1st distribution only bay. These cover panels are moved to the last distribution only bay in the bay line-up.

List 118: 1st Internal Bus Distribution Only Bay – Expansion to the Right

Features

- ◆ Provides common equipment for one (1) “distribution only” bay rated for up to 6000 amperes.
- ◆ Mounted in a 7'0"H x 31.375"W x 30"D seismic rated (Zone 4) box framework.
- ◆ Provides forty-eight (48) distribution device mounting positions.
- ◆ Provides four (4) buses of distribution. Each bus contains a monitoring circuit card; which can be set for Group A designation or Group B designation.
- ◆ Includes a router or CAN interface assembly for bay communication to the controller/monitor in the primary power bay.
- ◆ Network bay interconnect cable provided (P/N 514642).

Restrictions

The system must consist of one (1) primary power/distribution bay or primary power only bay and may consist of up to seven (7) additional bays. These additional bays may be a combination of secondary power/distribution bays, secondary power only bays, and/or distribution only bays (maximum of 4 distribution only bays per system).

Must be installed to the right of the power/distribution bay line-up (as viewed facing the front).

Cannot be installed ‘in-between’ power/distribution bays, only at the end of the power/distribution bay line-up.

Ordering Notes

- 1) Order distribution fuse and/or circuit breaker devices as required per [Distribution Devices](#) in the *ACCESSORY DESCRIPTIONS* section.
- 2) Order bay grounding lugs as required per [Distribution Only Bay Frame Grounding Wire Sizes and Lugs Selection](#) in the *ACCESSORY DESCRIPTIONS* section.
- 3) Order load distribution lugs as required per [Power/Distribution Bay and Distribution Only Bay Load Distribution Wire Sizes and Lugs](#) in the *ACCESSORY DESCRIPTIONS* section.
- 4) Order one (1) “Twenty-Four (24) Position Bullet-Nose Circuit Breaker/Fuse Panel” per distribution bay as required per [List C](#).
- 5) Side cover panels are provided with the 1st distribution only bay. These cover panels are moved to the last distribution only bay in the bay line-up.

List 19: Distribution Only Bay Expansion Busbars to Bridge PDSC

Features

- ◆ Provides busbars to connect the distribution only bay to a power/distribution bay when a PDSC is located between them.

Ordering Notes

- 1) Order List 19 distribution only bay expansion busbars when a PDSC is located between the distribution only bay and the power/distribution bay.

List 122: 1st Internal Bus Distribution Only Bay – Expansion to the Left

Features

- ◆ Provides common equipment for one (1) “distribution only” bay rated for up to 6000 amperes.
- ◆ Mounted in a 7'0"H x 31.375"W x 30"D seismic rated (Zone 4) box framework.
- ◆ Provides forty-eight (48) distribution device mounting positions.
- ◆ Provides four (4) buses of distribution. Each bus contains a monitoring circuit card; which can be set for Group A designation or Group B designation.
- ◆ Includes a router or CAN interface assembly for bay communication to the controller/monitor in the primary power bay.
- ◆ Network bay interconnect cable provided (P/N 514643).

Restrictions

The system must consist of one (1) primary power/distribution bay or primary power only bay and may consist of up to seven (7) additional bays. These additional bays may be a combination of secondary power/distribution bays, secondary power only bays, and/or distribution only bays (maximum of 4 distribution only bays per system).

Must be installed to the left of the power/distribution bay line-up (as viewed facing the front).

Cannot be installed ‘in-between’ power/distribution bays, only at the end of the power/distribution bay line-up.

Ordering Notes

- 1) Order distribution fuse and/or circuit breaker devices as required per [Distribution Devices](#) in the ACCESSORY DESCRIPTIONS section.
- 2) Order bay grounding lugs as required per [Distribution Only Bay Frame Grounding Wire Sizes and Lugs Selection](#) in the ACCESSORY DESCRIPTIONS section.
- 3) Order load distribution lugs as required per [Power/Distribution Bay and Distribution Only Bay Load Distribution Wire Sizes and Lugs](#) in the ACCESSORY DESCRIPTIONS section.
- 4) Order one (1) “Twenty-Four (24) Position Bullet-Nose Circuit Breaker/Fuse Panel” per distribution bay as required per [List C](#).
- 5) Side cover panels are provided with the 1st distribution only bay. These cover panels are moved to the last distribution only bay in the bay line-up.
- 6) Order [List 19](#) distribution only bay expansion busbars when a PDSC is located between the distribution only bay and the power/distribution bay.

List 130: Optional 480 VAC Input Bolt-On PDSC (AC Input 'Power Distribution Service Cabinet')

Features

- ◆ Provides an AC input service cabinet pre-wired to the rectifier mounting positions.
- ◆ Provides a 30 ampere AC input circuit breaker rated for 22kA interrupting capacity for each rectifier position. Circuit breakers are pad-lockable.
- ◆ Provides terminations for one or two AC input branch circuits.
- ◆ List 130 textured dark gray.

Ordering Notes

- 1) Order one (1) List 130, List 131, or List 132 as required for each [List 102](#) or [List 112](#) ordered.
- 2) Order a [List 35](#) if additional surge suppression is required.

List 131: Optional 480 VAC Input Bolt-On PDSC (AC Input 'Power Distribution Service Cabinet')

Features

- ◆ Provides an AC input service cabinet pre-wired to the rectifier mounting positions.
- ◆ Provides a 30 ampere AC input circuit breaker rated for 65kA interrupting capacity for each rectifier position. Circuit breakers are pad-lockable.
- ◆ Provides terminations for one or two AC input branch circuits.
- ◆ List 131 textured dark gray.

Ordering Notes

- 1) Order one (1) List 130, List 131, or List 132 as required for each [List 102](#) or [List 112](#) ordered.
- 2) Order a [List 35](#) if additional surge suppression is required.

List 132: Optional 208 VAC Input Bolt-On PDSC (AC Input 'Power Distribution Service Cabinet')

Features

- ◆ Provides an AC input service cabinet pre-wired to the rectifier mounting positions.
- ◆ Provides a 60 ampere AC input circuit breaker rated for 65kA interrupting capacity for each rectifier position. Circuit breakers are pad-lockable.
- ◆ Provides terminations for one or two AC input branch circuits.
- ◆ List 132 textured dark gray.

Ordering Notes

- 1) Order one (1) List 130, List 131, or List 132 as required for each [List 102](#) or [List 112](#) ordered.
- 2) Order a [List 36](#) if additional surge suppression is required.

List 35: Surge Suppression for 480 VAC Input PDSC

Features

- ◆ Provides two (2) surge suppression assemblies for the PDSC. One wired to rectifier AC input circuit breakers CB1, CB3, CB5, CB7, and CB9. The other to CB2, CB4, CB6, CB8, and CB10.
- ◆ 100kA interrupting capacity.
- ◆ Overcurrent fusing and thermal protection.

Restrictions

For use with [List 130](#) or [List 131](#) manufactured after 12/01/04 only.

See [Surge Protection](#) in the SPECIFICATION section for additional ratings.

Please note that List 35, List 36, List 37, and List 38 Transient Voltage Surge Protector (TVSS) units designed to be used with solidly grounded electrical systems and are not compatible with High Resistance Grounding for electrical systems. On a HRG system, L-G voltage rises to the rated line voltage during a bolted ground fault. At this voltage the TVSS which is expecting to see a Line to Neutral Voltage would read a Line to Line Voltage across it, which would stress the TVSS and eventually cause the TVSS to fail.

Ordering Notes

- 1) Order if additional surge suppression is required.
- 2) A wire harness is factory connected to Form-C relay contacts located on each surge suppression assembly for remote monitoring. Connect the wire harness to the controller's binary inputs. The controller then provides alarm display messages and an audible alarm when a surge suppression assembly activates.

List 36: Surge Suppression for 208 VAC Input PDSC

Features

- ◆ Provides two (2) surge suppression assemblies for the PDSC. One wired to rectifier AC input circuit breakers CB1, CB3, CB5, CB7, and CB9. The other to CB2, CB4, CB6, CB8, and CB10.
- ◆ 100kA interrupting capacity.
- ◆ Overcurrent fusing and thermal protection.

Restrictions

For use with [List 132](#) only.

See [Surge Protection](#) in the SPECIFICATION section for additional ratings.

Please note that List 35, List 36, List 37, and List 38 Transient Voltage Surge Protector (TVSS) units designed to be used with solidly grounded electrical systems and are not compatible with High Resistance Grounding for electrical systems. On a HRG system, L-G voltage rises to the rated line voltage during a bolted ground fault. At this voltage the TVSS which is expecting to see a Line to Neutral Voltage would read a Line to Line Voltage across it, which would stress the TVSS and eventually cause the TVSS to fail.

Ordering Notes

- 1) Order if additional surge suppression is required.
- 2) A wire harness is factory connected to Form-C relay contacts located on each surge suppression assembly for remote monitoring. Connect the wire harness to the controller's binary inputs. The controller then provides alarm display messages and an audible alarm when a surge suppression assembly activates.

List 37: Surge Suppression for 208 VAC Input

Features

- ◆ Provides two (2) surge suppression assemblies for the power only bay. One wired to rectifier AC input circuit breakers CB1, CB3, CB5, CB7, and CB9. The other to CB2, CB4, CB6, CB8, and CB10.
- ◆ 100kA interrupting capacity.
- ◆ Overcurrent fusing and thermal protection.

Restrictions

For use with [List 104](#) and [List 114](#).

See [Surge Protection](#) in the SPECIFICATION section for additional ratings.

Vertiv™ NetSure™ 8200 -48 VDC Power System

System Application Guide

Please note that List 35, List 36, List 37, and List 38 Transient Voltage Surge Protector (TVSS) units designed to be used with solidly grounded electrical systems and are not compatible with High Resistance Grounding for electrical systems. On a HRG system, L-G voltage rises to the rated line voltage during a bolted ground fault. At this voltage the TVSS which is expecting to see a Line to Neutral Voltage would read a Line to Line Voltage across it, which would stress the TVSS and eventually cause the TVSS to fail.

Ordering Notes

- 1) Order if additional surge suppression is required.
- 2) A wire harness is factory connected to Form-C relay contacts located on each surge suppression assembly for remote monitoring. Connect the wire harness to the controller's binary inputs. The controller then provides alarm display messages and an audible alarm when a surge suppression assembly activates.

List 38: Surge Suppression for 480 VAC Input

Features

- ◆ Provides two (2) surge suppression assemblies for the power only bay. One wired to rectifier AC input circuit breakers CB1, CB3, CB5, CB7, and CB9. The other to CB2, CB4, CB6, CB8, and CB10.
- ◆ 100kA interrupting capacity.
- ◆ Overcurrent fusing and thermal protection.

Restrictions

For use with [List 104](#) and [List 114](#).

See [Surge Protection](#) in the SPECIFICATION section for additional ratings.

Please note that List 35, List 36, List 37, and List 38 Transient Voltage Surge Protector (TVSS) units designed to be used with solidly grounded electrical systems and are not compatible with High Resistance Grounding for electrical systems. On a HRG system, L-G voltage rises to the rated line voltage during a bolted ground fault. At this voltage the TVSS which is expecting to see a Line to Neutral Voltage would read a Line to Line Voltage across it, which would stress the TVSS and eventually cause the TVSS to fail.

Ordering Notes

- 1) Order if additional surge suppression is required.
- 2) A wire harness is factory connected to Form-C relay contacts located on each surge suppression assembly for remote monitoring. Connect the wire harness to the controller's binary inputs. The controller then provides alarm display messages and an audible alarm when a surge suppression assembly activates.

List C: 24 Position Bullet-Nose Circuit Breaker/Fuse Panel

Features

- ◆ Provides twenty-four (24) bullet nose device positions.
- ◆ Accepts a choice of TLS/TPS-type fuseholders, bullet nose-type circuit breakers, or bullet nose-type GMT fuse modules.
- ◆ The List C Fuse/Circuit Breaker Panel is equipped with one (1) shunt for all distribution positions for controller load current measurements.
- ◆ Refer also to [Bullet Nose-Type Circuit Breakers and Bullet Nose-Type Fuseholders e/w TLS/TPS Fuses](#) and [Optional Bullet Nose-Type 10-Position GMT Fuse Module for List C](#).

Restrictions

Each List 116, List 117, List 118, List 122, distribution only bay can be equipped with only one (1) List C panel.

The List C Circuit Breaker/Fuse Panel requires distribution position #12 in the Bus #1 Distribution Panel.

Current monitoring for the List C Fuse/Circuit Breaker Panel is for the complete panel. Circuit breakers and/or fuses are not individually monitored.

When installed, the distribution only bay can be loaded with up to (47) 218 circuit breakers or (23) TPL fuses and (24) bullet nose circuit breakers or TLS/TPS fuses.

The List C Circuit Breaker/Fuse Panel is rated for a maximum continuous load of 500 amps.

The total load combination of List C and Distribution Panel #1 cannot exceed 1500A.

Ordering Notes

- 1) Order as 5821400000C.
- 2) Also order distribution fuses, circuit breakers, and/or bullet nose-type 10-position GMT fuse modules as required per [Distribution Devices](#) in the *ACCESSORY DESCRIPTIONS* section.

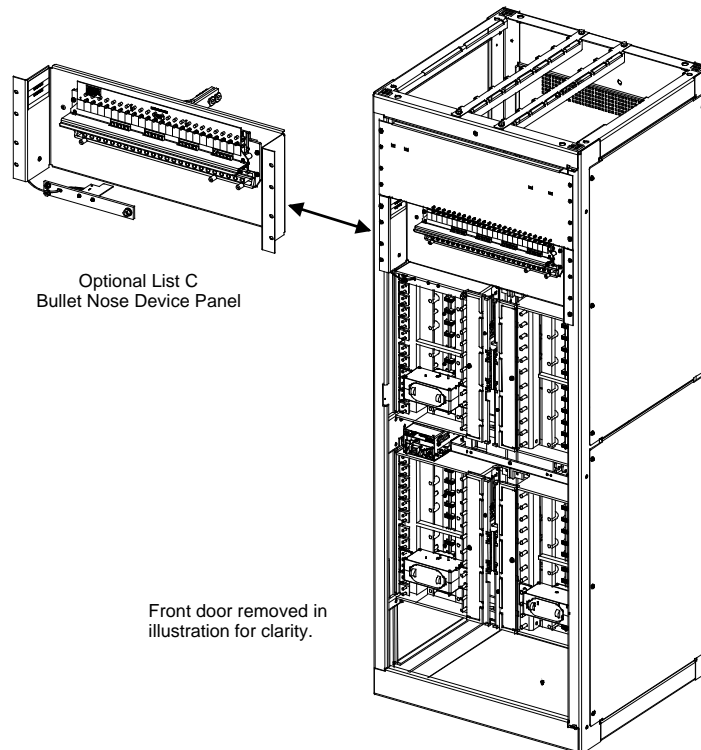

ACCESSORY DESCRIPTIONS

Rectifiers

P/N 486532603, Rectifier (480 VAC Input)

Features

- ◆ Consists of one (1) Model R48-12000e rectifier, Spec. No. 486532603.

Restrictions

Each power/distribution and power only bay holds up to ten (10) rectifiers.

Ordering Notes

- 1) Order as required.

P/N 486534003, Rectifier (208VAC Input)

Features

- ◆ Consists of one (1) Model R48-12000Le rectifier, Spec. No. 486534003.

Restrictions

Each power/distribution and power only bay holds up to ten (10) rectifiers.

Ordering Notes

- 1) Order as required.

External Main Termination Bars

Power only bays (List 103, List 104, List 105, List 113, List 114, and List 115) and distribution only bays (List 116, List 117, List 118, List 122) require external main battery termination bars. The following are standard sizes. Special requirements can be met with Vertiv Services EA type bars.

P/N	Ampere Rating	Power Bays	Distribution Bays
Without Shunts			
550281	3000A	1	1
550282	5000A	2	1
550283	5000A	2	2
550284	7500A	3	2
550285	7500A	3	3
550286	10,000A	4	2
550287	10,000A	4	3
With Shunts			
550291	3000A	1	1
550292	5000A	2	1
550293	5000A	2	2
550294	7500A	3	2
550295	7500A	3	3
550296	10,000A	4	2
550297	10,000A	4	3

Distribution Devices and Load Lug Locations - Power/Distribution Bays

Each power/distribution bay has two (2) distribution buses. Each distribution bus has twelve (12) fuse/circuit breaker device mounting positions. Note that the various fuse/circuit breaker devices require different number of mounting positions, as detailed in the following sections. Note also that each distribution bus is divided into half, and each half **MUST** be populated with distribution devices from left-to-right, without skipping any distribution device mounting positions within each half. The load side of each fuse/circuit breaker mounting position is bused up to the top of the bay. Each fuse/circuit breaker device requires a load lug adapter plate that mounts to the appropriate load side busbars at the top of the bay (except bullet nose-type devices which use the existing busbars provided at the top of the bay and do not require a lug adapter plate). Load return leads are terminated either inside the bay if equipped with the optional internal ground busbar, or outside the bay if equipped with the optional external ground busbar mounted on top of the bay (see [Optional Power/Distribution Bay Internal Ground Busbar Kits](#) and [Power/Distribution and Power Only Bays External Busbars](#) in this section).

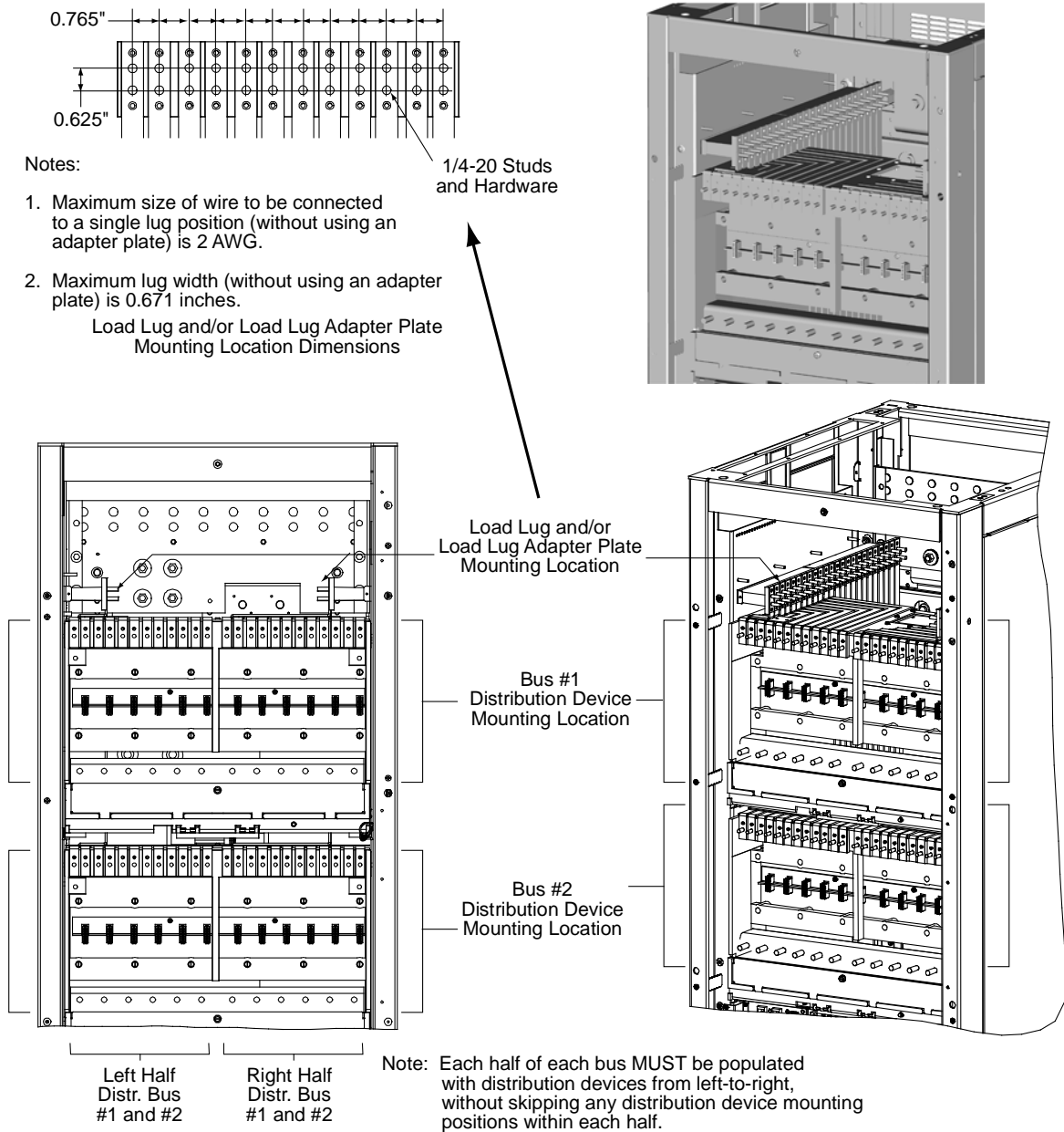

Vertiv™ NetSure™ 8200 -48 VDC Power System

System Application Guide

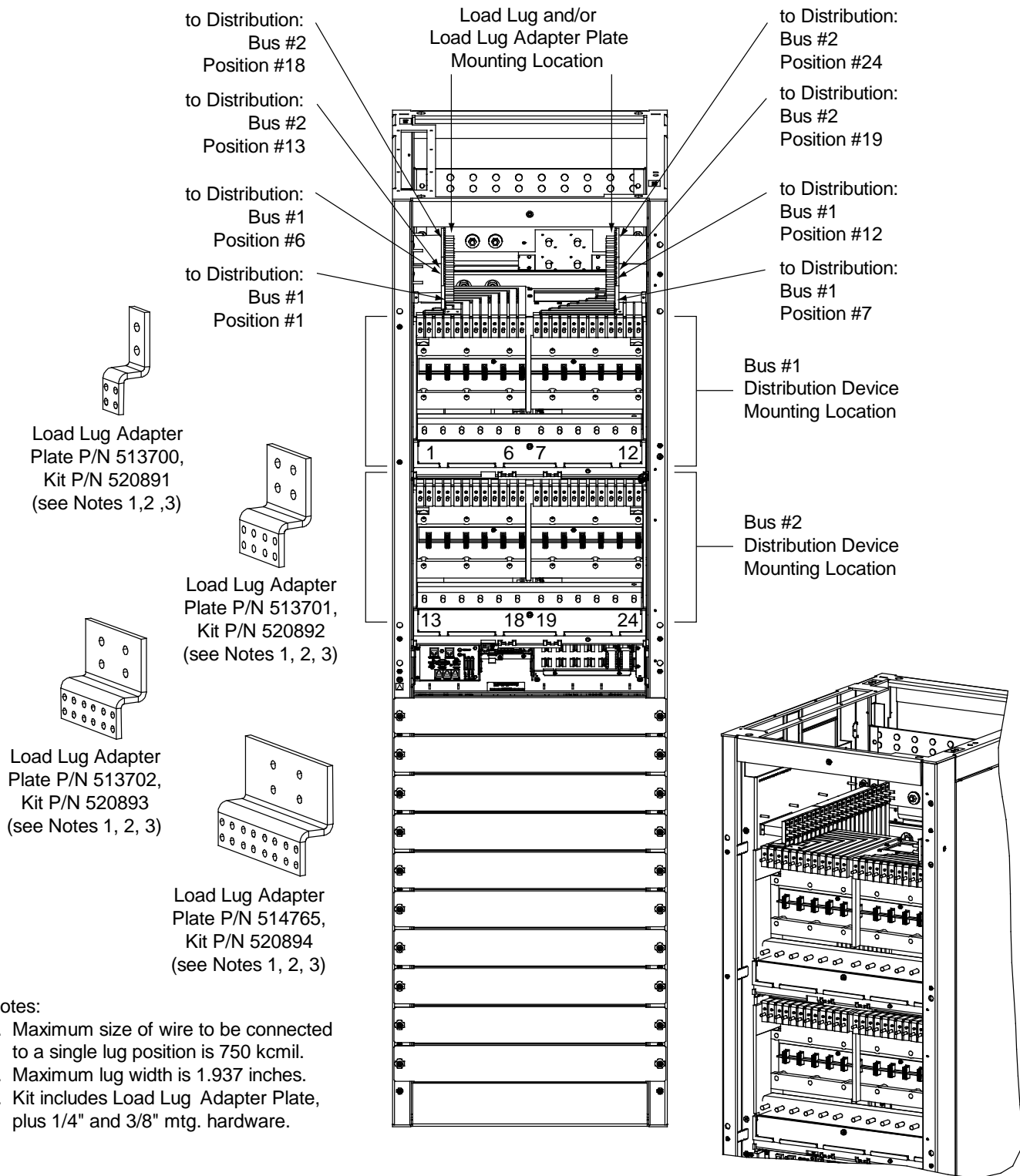

Distribution Device and Load Lug Locations – Distribution Only Bays

Each distribution bay has four (4) distribution buses. Each distribution bus has twelve (12) fuse/circuit breaker device mounting positions. Note that the various fuse/circuit breaker devices require different number of mounting positions, as detailed in the following sections. Note also that each distribution bus is divided into half, and each half **MUST** be populated with distribution devices as shown in the following illustration, without skipping any distribution device mounting positions within each half. This allows automatic monitoring of each position and allows the controller to locate all distribution positions. The load side of each fuse/circuit breaker mounting position is bused to the rear of the bay. Each fuse/circuit breaker device requires a load lug adapter plate kit that mounts to the appropriate load side busbars at the rear of the bay (except 1-pole devices). Load return leads are terminated outside the bay to customer provided return busbars. See following illustration.

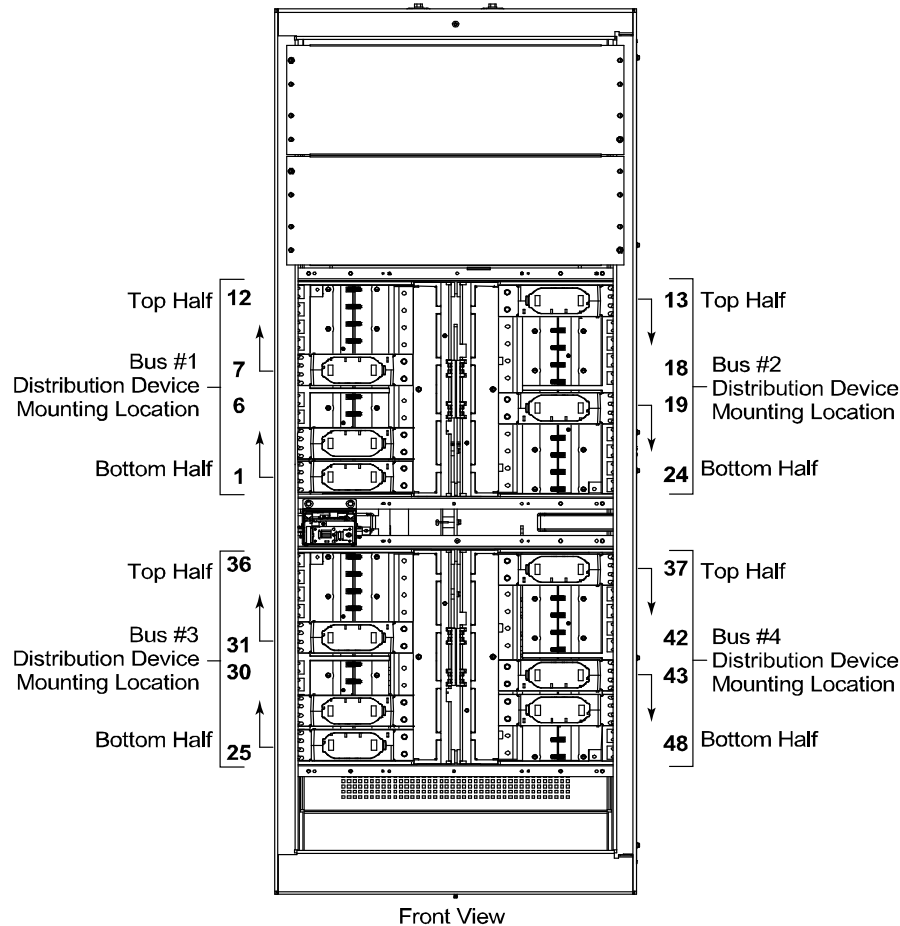

Front View
 Door removed in illustration for clarity.

Note: On the left side, each half of each bus **MUST** be populated with distribution devices from bottom-to-top, without skipping any distribution device mounting positions within each half. (Arrows indicate starting position in each half.)

Note: On the right side, each half of each bus **MUST** be populated with distribution devices from top-to-bottom, without skipping any distribution device mounting positions within each half. (Arrows indicate starting position in each half.)

This allows automatic monitoring of each position and allows the controller to located all distribution positions.

Load Lug Adapter Plates
 are Mounted on the
 Rear of the Bay

Vertiv™ NetSure™ 8200 -48 VDC Power System
 System Application Guide

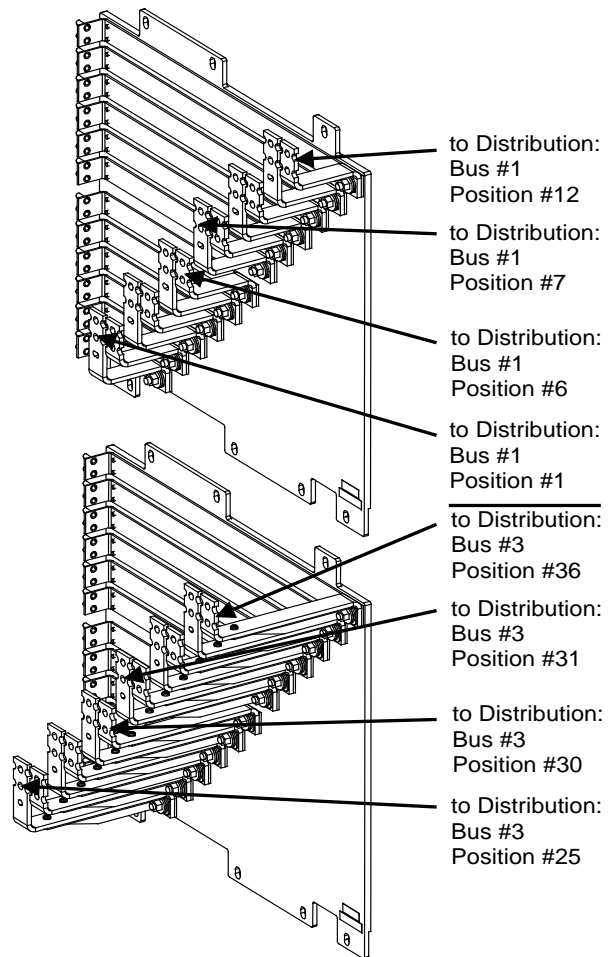
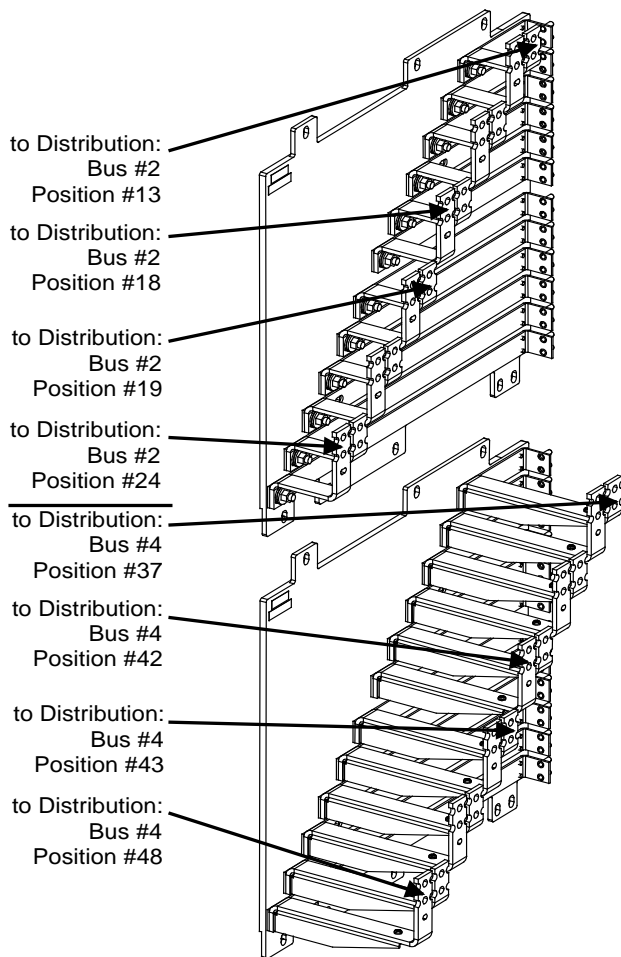
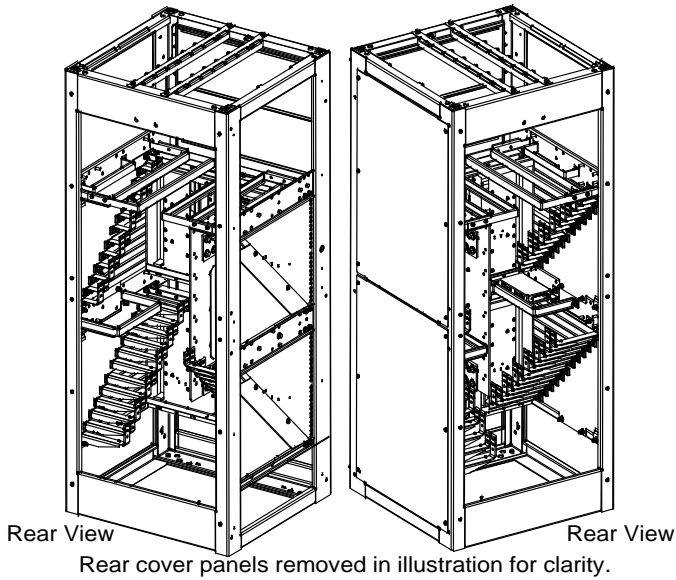

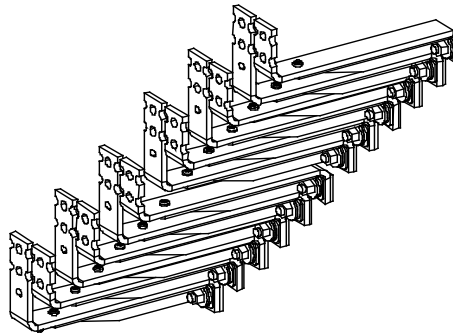

1-Position Devices
(Load Busbars with NO
Lug Adapters Installed)
(see Note 6)

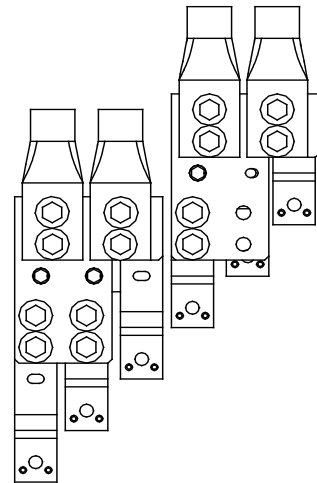

3-Position
Lug Adapter Kit
P/N 529131
(see Notes 2, 3, 4, 5)

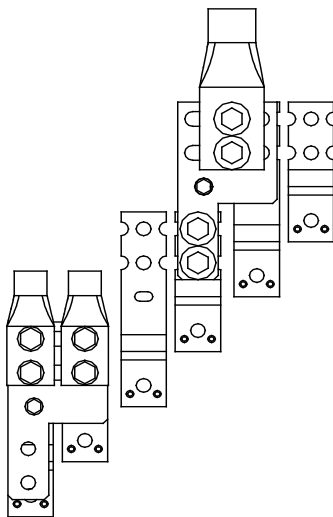

2-Position
Lug Adapter Kit
P/N 529132
(see Notes 1, 3, 4, 5)

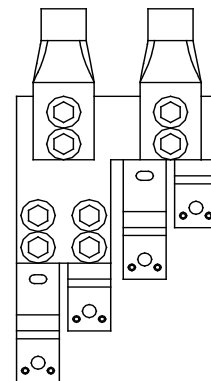

4-Position
Lug Adapter Kit
P/N 534420
(see Notes 2, 3, 4)

Notes:

1. Lug adapter accepts a maximum of (2) 750 kcmil or (4) 350 kcmil lugs.
2. Lug adapter accepts a maximum of (4) 750 kcmil lugs.
3. Lugs are not part of the kit, shown for illustration only.
4. Bay busbars are not part of the kit, shown for illustration only.
5. Two (2) kits shown for illustration of the kit installed on busbars with tops even with each other and staggered.
6. Maximum lug width (without using an adapter plate) is 1.250 inches.

Distribution Devices

See [Distribution Devices and Load Lug Locations - Power/Distribution Bays](#) and [Distribution Device and Load Lug Locations - Distribution Only Bays](#) at the beginning of this section for illustrations of distribution device and load lug mounting locations.

218 Circuit Breaker Assemblies

Features

- ◆ Each circuit breaker assembly is equipped with a shunt for load current measurements.
- ◆ Bolts into bay's distribution device mounting positions.
- ◆ Load lug adapter plate provides 3/8" clearance holes on 1" centers for installation of customer provided two-hole lugs. For load return lug requirements, refer to [Power/Distribution and Power Only Bays External Busbars](#) in this section. For the distribution only bays, the load return leads are terminated outside the bay to customer provided return busbars.

Restrictions

Load should not exceed 80% of device rating.

Refer to [Table 1](#) for required distribution bus mounting positions.

Each distribution bus is divided into half. Each half **MUST** be populated with distribution devices as shown in the illustrations at the beginning of this section, without skipping any distribution device mounting positions within each half.

Four (4) position devices can only be installed in the 1st four or last four positions within each half of a distribution bus. This is because the lug adapter plate for four (4) position devices can only be installed in positions starting with the load busbar tops even with each other (not staggered).

Divide distribution equally between rows.

Refer to the illustrations in this section for lug and wire size restrictions.

Load return leads are terminated outside the distribution only bay to customer provided return busbars.

Ordering Notes

- 1) Order circuit breaker assemblies and load lug adapter kits per [Table 1](#). Load lug adapter kits also contain the necessary hardware to mount the circuit breakers. For 1-pole circuit breakers in a List 116, List 117, List 118, List 122 Distribution Only Bay, also order circuit breaker hardware kit P/N 558709. This hardware is used to mount the circuit breaker.
- 2) See [Table 9](#) for recommended load distribution wire sizes and lugs.

Vertiv™ NetSure™ 8200 -48 VDC Power System
System Application Guide

Ampere Rating	No. of Poles	Required Distribution Bus Mounting Positions for Power/Distribution Bay or Distribution Only Bay	Circuit Breaker Part Number		Lug Adapter Kit Part Number	
			Electrical Trip ¹ (White Handle)	Electrical/Mechanical Trip ² (Black Handle)	Power/Distribution Bay	Distribution Only Bay
100	1	1	513766	513767	520891	not required
125	1	1	513768	513769	520891	not required
150	1	1	513770	513771	520891	not required
175	1	1	513772	513773	520891	not required
200	1	1	513774	513775	520891	not required
225	1	1	513776	513777	520891	not required
250	1	1	513778	513779	520891	not required
300	2	2	513780	513781	520892	529132
350	2	2	513782	513783	520892	529132
400	2	2	513784	513785	520892	529132
450	3	3	513786	513787	520893	529131
500	3	3	513788	513789	520893	529131
600	3	3	513790	513791	520893	529131
800	4	4	513792	513793	520894	534420
See Table 9 for recommended load distribution wire sizes and lugs.						

Circuit Breaker Alarm Operation:

- ¹ Provides an alarm during an electrical trip condition only.
- ² Provides an alarm during an electrical or manual trip condition.

Table 1
218 Circuit Breaker Assemblies

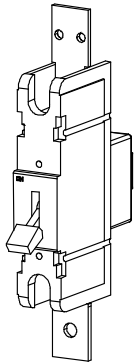

1-Pole 218 Circuit Breaker Assemblies

**Lug Adapter Kits
Power/Distribution Bays**

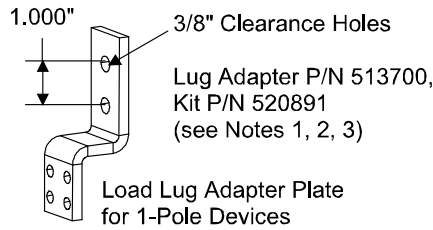

**Lug Adapter Kits
Distribution Only Bays**

NO LUG ADAPTER KITS
REQUIRED WHEN USED IN
DISTRIBUTION ONLY BAYS

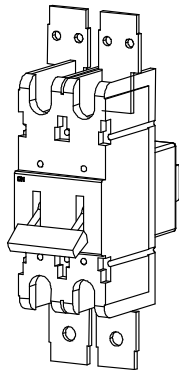

2-Pole 218 Circuit Breaker Assemblies

**Lug Adapter Kits
Power/Distribution Bays**

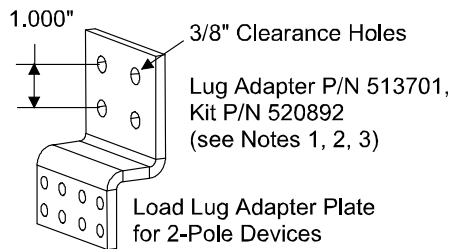

**Lug Adapter Kits
Distribution Only Bays**

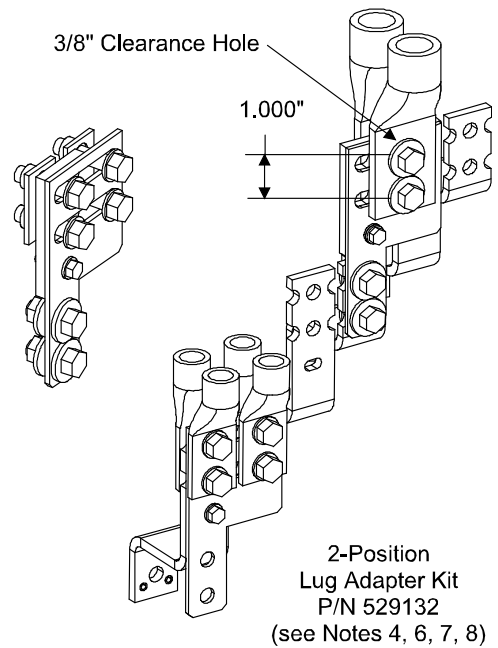

Notes:

1. Maximum size of wire to be connected to a single lug position is 750 kcmil.
2. Maximum lug width is 1.937 inches.
3. Kit includes Load Lug Adapter Plate, plus 1/4" and 3/8" mtg. hardware.
4. Lug adapter accepts a maximum of (2) 750 kcmil or (4) 350 kcmil lugs.
5. Lug adapter accepts a maximum of (4) 750 kcmil lugs.
6. Lugs are not part of the kit, shown for illustration only.
7. Bay busbars are not part of the kit, shown for illustration only.
8. Two (2) kits shown for illustration of the kit installed on busbars with tops even with each other and staggered.

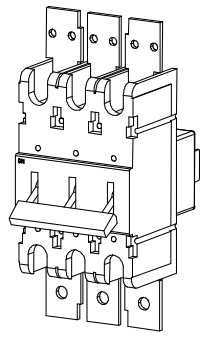

3-Pole 218 Circuit Breaker Assemblies

**Lug Adapter Kits
Power/Distribution Bays**

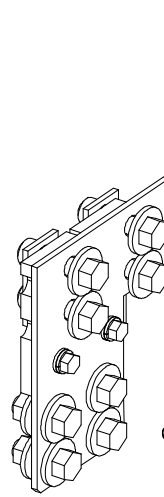
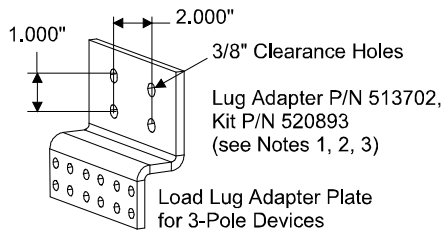

**Lug Adapter Kits
Distribution Only Bays**

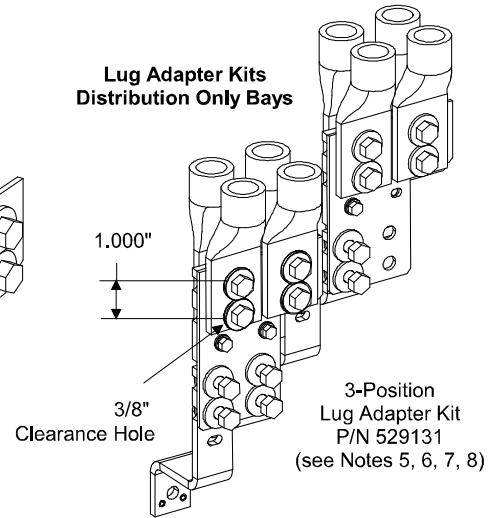

**Lug Adapter Kits
Power/Distribution Bays**

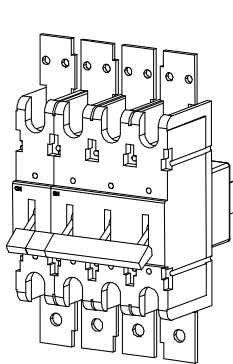

4-Pole 218 Circuit Breaker Assemblies

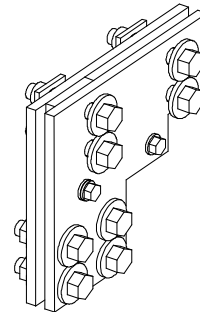
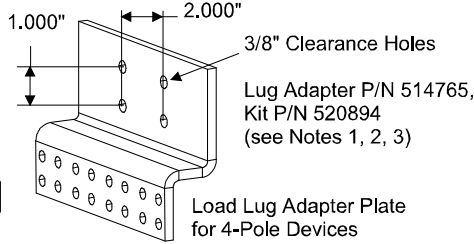

**Lug Adapter Kits
Distribution Only Bays**

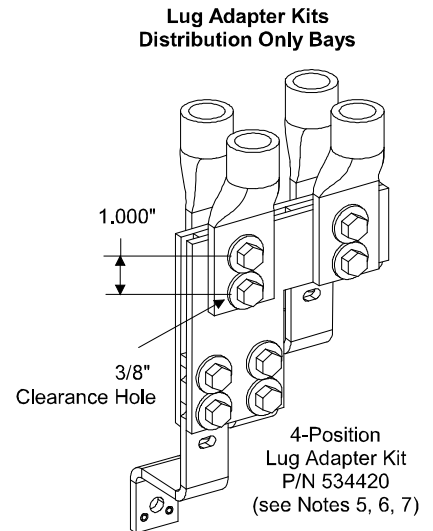

Notes:

1. Maximum size of wire to be connected to a single lug position is 750 kcmil.
2. Maximum lug width is 1.937 inches.
3. Kit includes Load Lug Adapter Plate, plus 1/4" and 3/8" mtg. hardware.
4. Lug adapter accepts a maximum of (2) 750 kcmil or (4) 350 kcmil lugs.
5. Lug adapter accepts a maximum of (4) 750 kcmil lugs.
6. Lugs are not part of the kit, shown for illustration only.
7. Bay busbars are not part of the kit, shown for illustration only.
8. Two (2) kits shown for illustration of the kit installed on busbars with tops even with each other and staggered.

TPL Fuses and Fuseholder Assemblies

Features

- ◆ Each fuseholder assembly is equipped with a shunt for load current measurements.
- ◆ Bolts into bay's distribution device mounting positions.
- ◆ Load lug adapter plate provides 3/8" clearance holes on 1" centers for installation of customer provided two-hole lugs. For load return lug requirements, refer to [Power/Distribution and Power Only Bays External Busbars](#) in this section. For the distribution only bays, the load return leads are terminated outside the bay to customer provided return busbars.

Restrictions

Load should not exceed 80% of device rating.

Refer to [Table 2](#) for required distribution bus mounting positions.

Each distribution bus is divided into half. Each half **MUST** be populated with distribution devices as shown in the illustrations at the beginning of this section, without skipping any distribution device mounting positions within each half.

Divide distribution equally between rows.

Refer to the illustrations in this section for lug and wire size restrictions.

Load return leads are terminated outside the distribution only bay to customer provided return busbars.

Ordering Notes

- 1) Order fuses, the appropriate fuseholder assembly for each fuse, and load lug adapter kits per [Table 2](#). Load lug adapter kits also contain the necessary hardware to mount the fuseholder assembly.
- 2) For each fuse ordered, also order one (1) P/N 248610301 alarm fuse, and one (1) P/N 248898700 safety fuse cover.
- 3) See [Table 9](#) for recommended load distribution wire sizes and lugs.

Ampere Rating	Required Distribution Bus Mounting Positions for Power/Distribution Bay or Distribution Only Bay	Part Number		Lug Adapter Kit Part Number	
		Fuse	Fuseholder Assembly	Power/Distribution Bay	Distribution Only Bay
70	2	248251500	514403	520892	529132
80	2	248252000	514403	520892	529132
100	2	248252600	514403	520892	529132
150	2	248253300	514403	520892	529132
200	2	248254000	514403	520892	529132
225	2	248254500	514403	520892	529132
250	2	248255000	514403	520892	529132
300	2	248255700	514403	520892	529132
400	2	248257000	514403	520892	529132
500	2	248258000	514403	520892	529132
600	2	248259000	514403	520892	529132
800	3	102901	514404	520893	529131
For each fuse ordered, also order: one (1) P/N 248610301 alarm fuse (GMT-18/100A), and one (1) P/N 248898700 safety fuse cover (GMT-X).					
See Table 9 for recommended load distribution wire sizes and lugs.					

Table 2
TPL Fuses and Fuseholder Assemblies

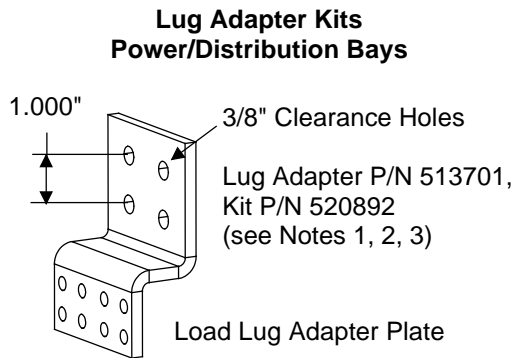
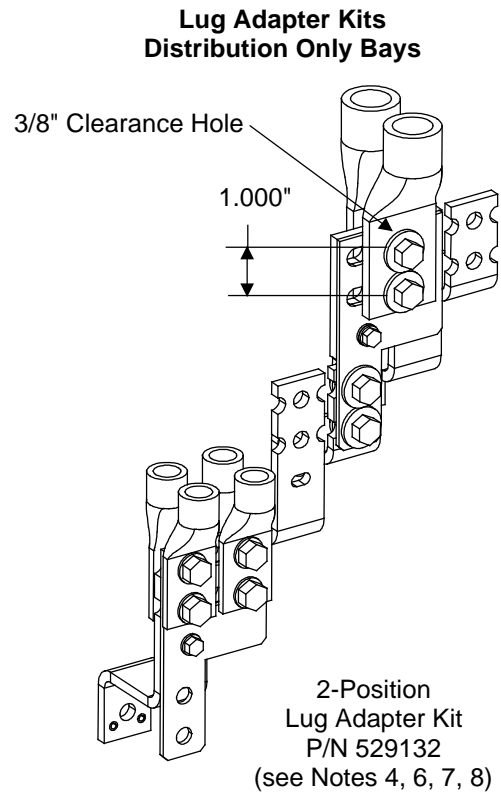
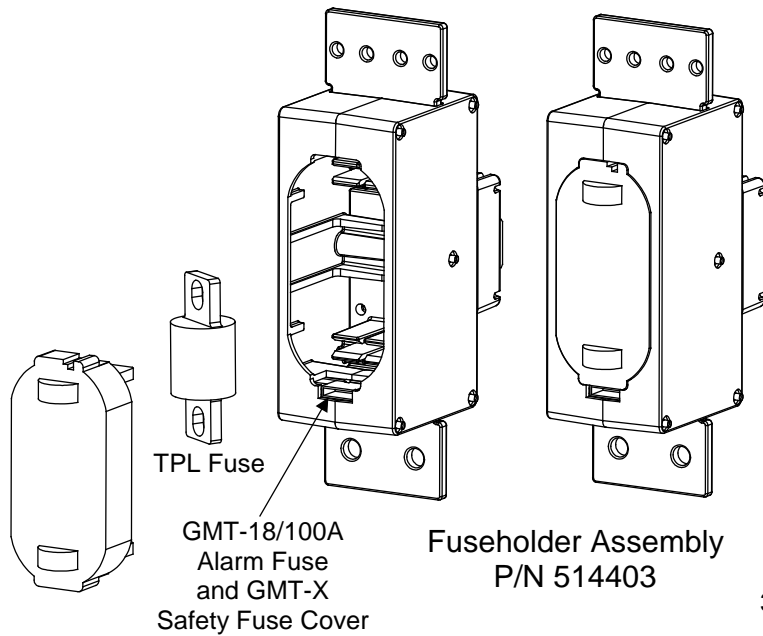

Notes:

1. Maximum size of wire to be connected to a single lug position is 750 kcmil.
2. Maximum lug width is 1.937 inches.
3. Kit includes Load Lug Adapter Plate, plus 1/4" and 3/8" mtg. hardware.
4. Lug adapter accepts a maximum of (2) 750 kcmil or (4) 350 kcmil lugs.
5. Lug adapter accepts a maximum of (4) 750 kcmil lugs.
6. Lugs are not part of the kit, shown for illustration only.
7. Bay busbars are not part of the kit, shown for illustration only.
8. Two (2) kits shown for illustration of the kit installed on busbars with tops even with each other and staggered.

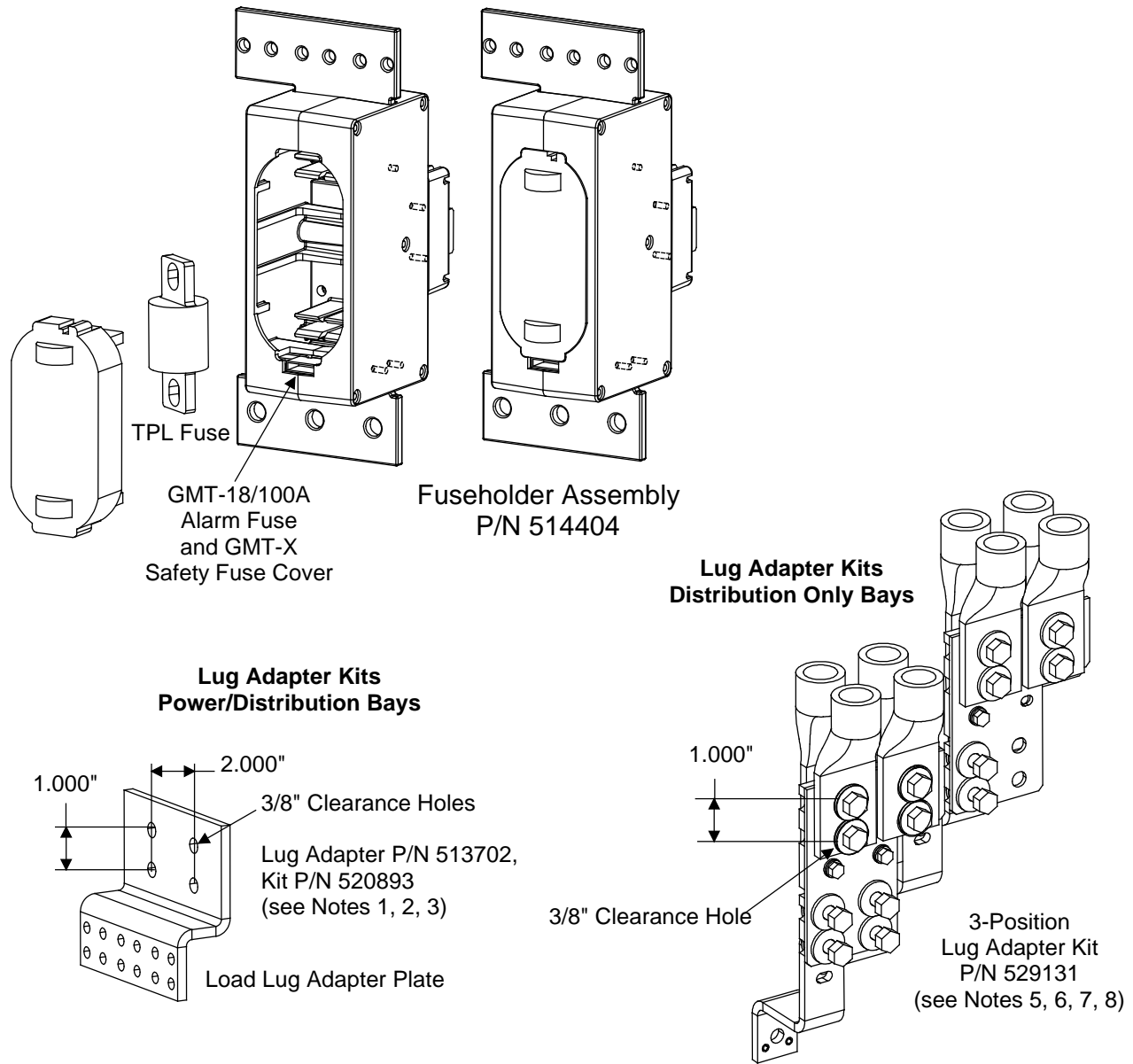

Notes:

1. Maximum size of wire to be connected to a single lug position is 750 kcmil.
2. Maximum lug width is 1.937 inches.
3. Kit includes Load Lug Adapter Plate, plus 1/4" and 3/8" mtg. hardware.
4. Lug adapter accepts a maximum of (2) 750 kcmil or (4) 350 kcmil lugs.
5. Lug adapter accepts a maximum of (4) 750 kcmil lugs.
6. Lugs are not part of the kit, shown for illustration only.
7. Bay busbars are not part of the kit, shown for illustration only.
8. Two (2) kits shown for illustration of the kit installed on busbars with tops even with each other and staggered.

**Bullet Nose-Type Circuit Breakers and
Bullet Nose-Type Circuit Breaker/Fuseholder Mounting Assembly – Power/Distribution Bays**

Features

- ◆ Each bullet nose-type circuit breaker/fuseholder mounting assembly can mount up to six (6) bullet nose-type circuit breakers and/or fuseholders.
- ◆ Each bullet nose-type circuit breaker/fuseholder mounting assembly is equipped with a shunt for load current measurements (one shunt per six bullet nose-type devices).
- ◆ Bolts into bay's distribution device mounting positions.
- ◆ Load lugs are connected to the existing load busbars provided at the top of the Power/Distribution Bay. These busbars provide 1/4-20 studs on 5/8" centers and hardware for installation of customer provided two-hole lugs. For load return lug requirements, refer to [Power/Distribution and Power Only Bays External Busbars](#) in this section.

Restrictions

Load should not exceed 80% of device rating.

Each bullet nose-type circuit breaker/fuseholder mounting assembly requires six (6) distribution bus mounting positions.

Each distribution bus is divided into half. Each half **MUST** be populated with distribution devices from left-to-right, without skipping any distribution device mounting positions within each half.

Bullet nose-type circuit breaker/fuseholder mounting assembly rated for 480 amperes, maximum.

Caution: *An overcurrent protective device with a rating of 150 amperes or greater SHALL HAVE an empty mounting position between it and any other overcurrent protective device within the circuit breaker/fuseholder mounting assembly.*

Refer to the illustrations at the beginning of this section for maximum size of wire to be connected to a single lug position and maximum lug width.

Ordering Notes

- 1) Order circuit breakers per [Table 3](#) and [Table 4](#).
- 2) Order a bullet nose-type circuit breaker/fuseholder mounting assembly, P/N 513747, for every six circuit breaker/fuseholder combinations ordered.
- 3) See [Table 9](#) for recommended load distribution wire sizes and lugs.

Ampere Rating	Number of Poles (and mounting positions required in Bullet Nose-Type Circuit Breaker/Fuseholder Mounting Assembly)	Part Number	
		Electrical Trip ¹ (White Handle)	Electrical/ Mechanical Trip ² (Black Handle)
1	1	102272	101596
3	1	102273	101597
5	1	102274	101598
10	1	102275	101599
15	1	102276	101600
20	1	102277	101601
25	1	102278	101602
30	1	102279	101603
35	1	102280	101604
40	1	102281	101605
45	1	121998	121997
50	1	102282	101606
60	1	102283	101607
70	1	102284	101608
75	1	102285	101609
80	1	121996	121995
90	1	138887	138888
100	1	102286	101610
125	2	516991	516838
150 (see Caution below)	2	516993	516839
175 (see Caution below)	2	144883	144884
200 (see Caution below)	2	121831	121832
225 (see Caution below)	3	144885	144886
Order a Bullet Nose-Type Circuit Breaker/Fuseholder Mounting Assembly, P/N 513747, for every six circuit breaker/fuseholder combinations ordered. Each bullet nose-type circuit breaker/fuseholder mounting assembly requires six (6) distribution bus mounting positions.			
See Table 9 for recommended load distribution wire sizes and lugs.			

Circuit Breaker Alarm Operation:

- ¹ Provides an alarm during an electrical trip condition only.
- ² Provides an alarm during an electrical or manual trip condition.

Caution: *An overcurrent protective device with a rating of 150 amperes or greater SHALL HAVE an empty mounting position between it and any other overcurrent protective device within the circuit breaker/fuseholder mounting assembly.*

Table 3
Toggle-Handle Bullet Nose-Type Circuit Breakers and Bullet Nose-Type
Circuit Breaker/Fuseholder Mounting Assembly

Ampere Rating	Number of Poles (and mounting positions required in Bullet Nose-Type Circuit Breaker/Fuseholder Mounting Assembly)	Part Number	
		Electrical Trip ¹ (White Handle)	Electrical/ Mechanical Trip ² (Black Handle)
1	1	142856	142878
3	1	142857	142879
5	1	142858	142880
10	1	142859	142881
15	1	142861	142882
20	1	142862	142883
25	1	142863	142884
30	1	142864	142885
35	1	142865	142886
40	1	142866	142887
45	1	142867	142888
50	1	142868	142889
60	1	142869	142890
70	1	142870	142891
75	1	142871	142892
80	1	142872	142901
100	1	142873	142902
125	2	142874	142903
150 (see Caution below)	2	142875	142904
200 (see Caution below)	2	142876	142905
Order a Bullet Nose-Type Circuit Breaker/Fuseholder Mounting Assembly, P/N 513747, for every six circuit breaker/fuseholder combinations ordered. Each bullet nose-type circuit breaker/fuseholder mounting assembly requires six (6) distribution bus mounting positions.			
See Table 9 for recommended load distribution wire sizes and lugs.			

Circuit Breaker Alarm Operation:

- ¹ Provides an alarm during an electrical trip condition only.
- ² Provides an alarm during an electrical or manual trip condition.

Caution: *An overcurrent protective device with a rating of 150 amperes or greater SHALL HAVE an empty mounting position between it and any other overcurrent protective device within the circuit breaker/fuseholder mounting assembly.*

Table 4
Rocker-Handle Bullet Nose-Type Circuit Breakers and Bullet Nose-Type
Circuit Breaker/Fuseholder Mounting Assembly

**TLS/TPS Fuses, Bullet Nose-Type Fuseholders, and
Bullet Nose-Type Circuit Breaker/Fuseholder Mounting Assembly – Power/Distribution Bays**

Features

- ◆ Each bullet nose-type circuit breaker/fuseholder mounting assembly can mount up to six (6) bullet nose-type circuit breakers and/or fuseholders.
- ◆ Each bullet nose-type circuit breaker/fuseholder mounting assembly is equipped with a shunt for load current measurements (one shunt per six bullet nose-type devices).
- ◆ Bolts into bay's distribution device mounting positions.
- ◆ Load lugs are connected to the existing load busbars provided at the top of the Power/Distribution Bay. These busbars provide 1/4-20 studs on 5/8" centers and hardware for installation of customer provided two-hole lugs. For load return lug requirements, refer to [Power/Distribution and Power Only Bays External Busbars](#) in this section.

Restrictions

Load should not exceed 80% of device rating.

Each bullet nose-type circuit breaker/fuseholder mounting assembly requires six (6) distribution bus mounting positions.

Each distribution bus is divided into half. Each half **MUST** be populated with distribution devices from left-to-right, without skipping any distribution device mounting positions within each half.

Bullet nose-type circuit breaker/fuseholder mounting assembly rated for 480 amperes, maximum.

Caution: *An overcurrent protective device with a rating of 150 amperes or greater SHALL HAVE an empty mounting position between it and any other overcurrent protective device within the circuit breaker/fuseholder mounting assembly.*

Refer to the illustrations at the beginning of this section for maximum size of wire to be connected to a single lug position and maximum lug width.

Ordering Notes

- 1) Order fuses per [Table 5](#).
- 2) For each fuse ordered, also order a Bullet Nose-Type Fuseholder P/N 117201.
Note: *Fuseholder P/N 117201 also includes...*
(1) Alarm Fuse P/N 248610301 and
(1) Safety Fuse Cover P/N 248898700.
- 3) Order a Bullet Nose-Type Circuit Breaker/Fuseholder Mounting Assembly, P/N 513747, for every six circuit breaker/fuseholder combinations ordered.
- 4) See [Table 9](#) for recommended load distribution wire sizes and lugs.

Ampere Rating	Part Number	Bussmann P/N	Littelfuse P/N
3	248230900	TPS-3	TLS003
5	248231000	TPS-5	TLS005
6	248231200	TPS-6	TLS006
10	248231500	TPS-10	TLS010
15	248231800	TPS-15	TLS015
20	248232100	TPS-20	TLS020
25	248232400	TPS-25	TLS025
30	248232700	TPS-30	TLS030
40	248233300	TPS-40	TLS040
50	248233900	TPS-50	TLS050
60	248234200	TPS-60	TLS060
70	248234500	TPS-70	TLS070
80	118413	--	TLS080
90	118414	--	TLS090
100	118415	--	TLS100
<p>For each fuse ordered, also order a Bullet Nose-Type Fuseholder P/N 117201.</p> <p>Fuseholder P/N 117201 also includes...</p> <p>(1) P/N 248610301 alarm fuse (GMT-18/100A), and</p> <p>(1) P/N 248898700 safety fuse cover (GMT-X).</p>			
<p>Order a Bullet Nose-Type Circuit Breaker/Fuseholder Mounting Assembly, P/N 513747, for every six circuit breaker/fuseholder combinations ordered. Each bullet nose-type circuit breaker/fuseholder mounting assembly requires six (6) distribution bus mounting positions.</p>			
<p>See Table 9 for recommended load distribution wire sizes and lugs.</p>			

Table 5
TLS/TPS Fuses, Bullet Nose-Type Fuseholders, and
Bullet Nose-Type Circuit Breaker/Fuseholder Mounting Assembly

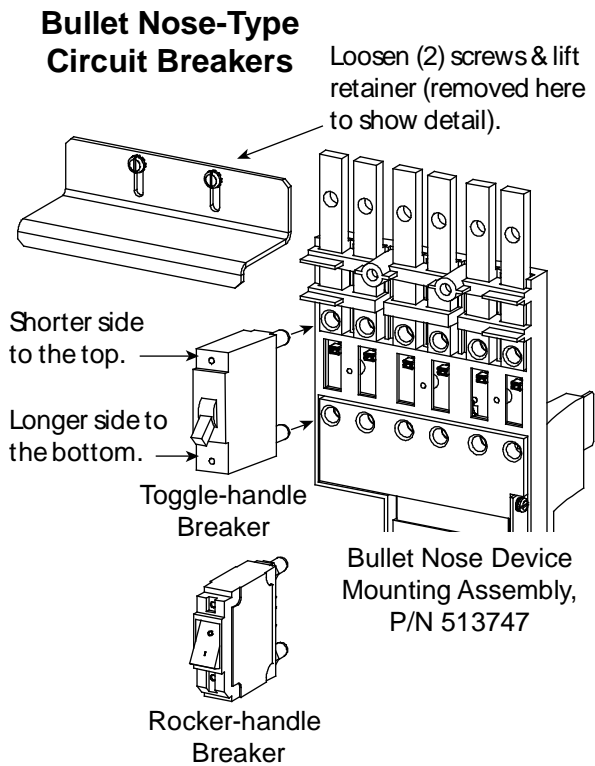
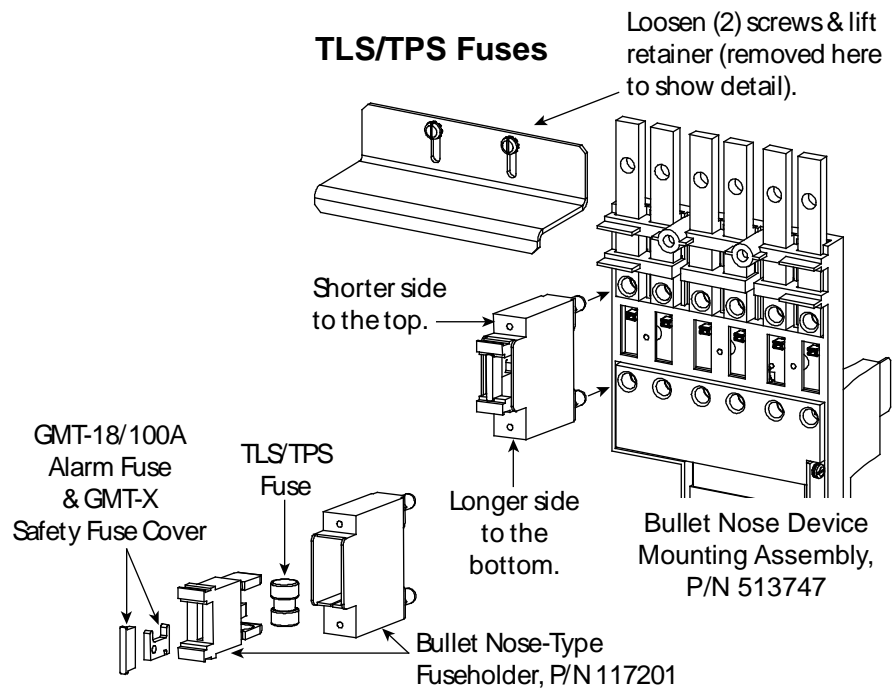

Note: Load leads are connected to the existing load busbars provided at the top of the bay. These busbars provide 1/4" studs on 5/8" centers and hardware for installation of customer provided two-hole lugs.

Bullet Nose-Type Circuit Breakers and Bullet Nose-Type Fuseholders e/w TLS/TPS Fuses – Distribution Only Bays

Features

- ◆ Installs in the optional [List C](#) Fuse/Circuit Breaker Panel.
- ◆ Load lugs are connected to busbars provided on the List C Fuse/Circuit Breaker Panel. These busbars provide 1/4-20 threaded holes on 5/8" centers for installation of customer provided two-hole lugs. Load return leads are terminated outside the bay to customer provided return busbars.
- ◆ Each circuit breaker (as listed in [Table 3](#) and [Table 4](#)) plugs into one, two, or three mounting position(s).
- ◆ A single fuseholder provides for installation of a 3 to 100 ampere Bussmann TPS-type or Littelfuse TLS-type fuse (as listed in [Table 5](#)). This fuseholder plugs into a single mounting position. This fuseholder provides a GMT-A alarm type fuse, which operates open to provide an alarm indication if the associated distribution fuse opens.

Restrictions

Load should not exceed 80% of device rating.

Caution: *An overcurrent protective device with a rating of 150 amperes or greater SHALL HAVE an empty mounting position between it and any other overcurrent protective device within the List C Fuse/Circuit Breaker Panel.*

Maximum size of wire to be connected to a single lug position is 2 AWG.

Maximum lug width is 0.610.

Customer must provide lug mounting bolts and additional hardware.

Bolt length: 3/4".

Load return leads are terminated outside the bay to customer provided return busbars.

Ordering Notes

- 1) Order circuit breakers per [Table 3](#) and [Table 4](#).
- 2) Order fuses per Table 5. For each fuse ordered, also order one (1) P/N 117201 bullet nose type fuseholder.
- 3) See Table 9 for recommended load distribution wire sizes and lugs.

Note: Load Leads are connected to load busbars.
 These busbars provide 1/4-20 threaded holes
 on 5/8" centers for installation of customer
 provided two-hole lugs. Customer must
 provide lug mounting bolts and additional
 hardware. Bolt length: 3/4".

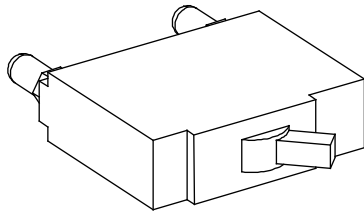
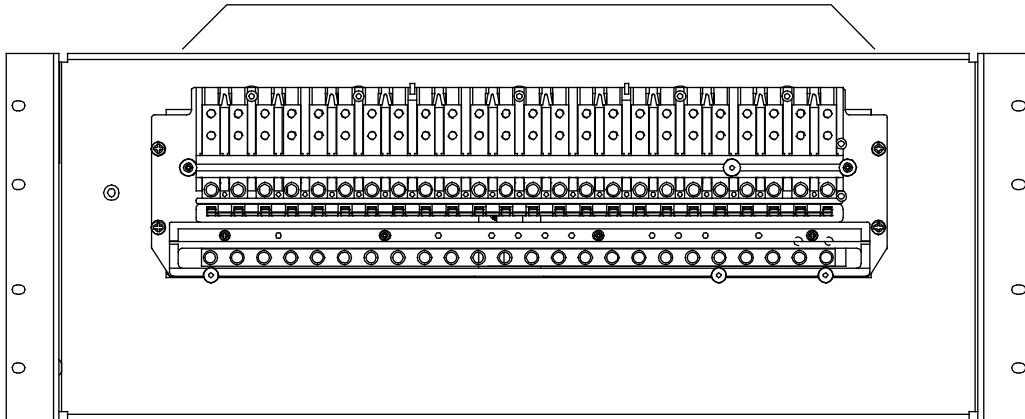

Toggle Handle Bullet Nose Circuit Breaker

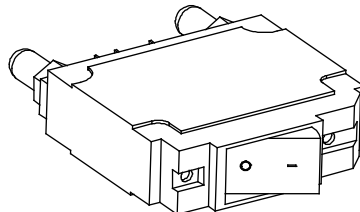

Rocker Handle Bullet Nose Circuit Breaker

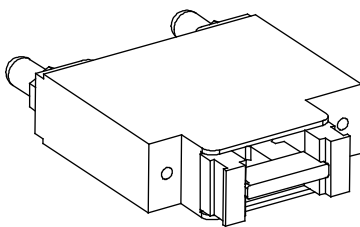

Bullet Nose Fuseholder

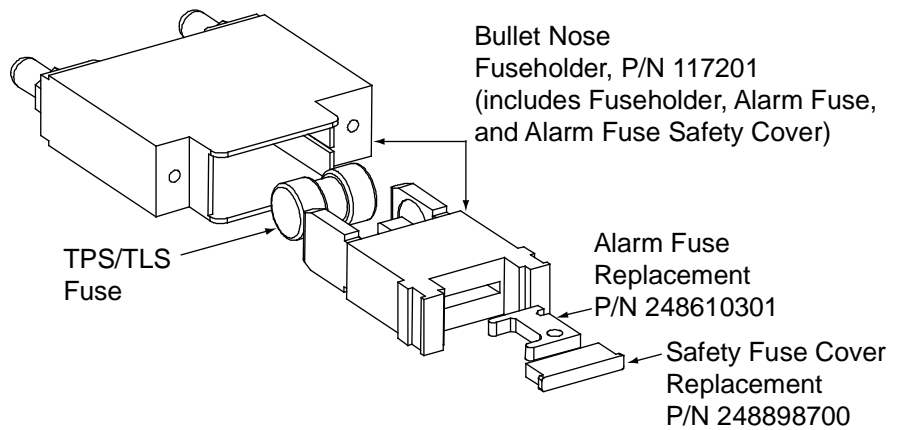

Optional Bullet Nose-Type 10-Position GMT Fuse Module for List C

Features

- ◆ Installs in the optional [List C](#) Fuse/Circuit Breaker Panel.
- ◆ Provides 10 GMT fuse positions.
(1/4A to 15A GMT Alarm-Type Fuses).
- ◆ Screw clamp type load and load return terminals provided.
- ◆ Includes ten dummy fuses equipped with safety fuse covers.
- ◆ Includes 35 A input fuse and associate alarm fuse.

Restrictions

30 A maximum capacity per block.

Terminal block wire size capacity: 24 to 14 AWG.

Requires five (5) bullet device mounting positions.

When used for power distribution, load should not exceed 80% of device rating, except 10 and 15 Amp fuses, for which load should not exceed 70% of device rating.

Ordering Notes

- 1) Order optional Bullet Nose-Type 10-Position GMT Fuse Module (P/N 509128) as required.
- 2) Order GMT fuses as required per Table 6.
- 3) See "[Replacement Alarm, Reference, and Control Fuses](#)" and Table 8 for ordering replacement input fuse and associated alarm fuse.

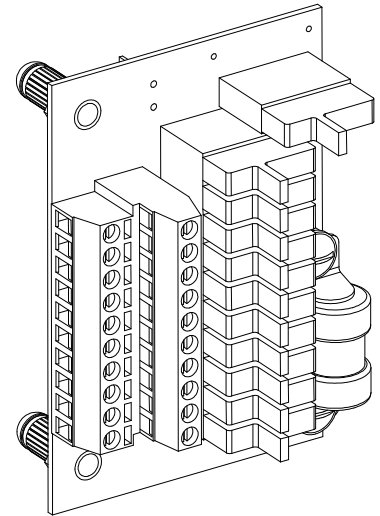

P/N 509128
GMT Fuse Module

Ampere Rating	Part Number	Fuse Color
18/100 GMT-A	248610301	---
1/4	248610200	VIOLET
1/2	248610300	RED
3/4	248610500	BROWN
1-1/3	248610700	WHITE
2	248610800	ORANGE
3	248610900	BLUE
5	248611000	GREEN
7-1/2	248611300	BLACK-WHITE
10	248611200	RED-WHITE
15	248611500	RED-BLUE
Replacement Safety Fuse Cover	102774	---
Replacement Dummy Fuse	248872600	---

Table 6
Bussmann GMT-Type Fuses

Replacement Alarm, Reference, and Control Fuses (List 101, 102, 103, 104, 105, 111, 112, 113, 114, 115, 116, 117, 118, 122)

Located in Bay's Center Section

Features

- ◆ Alarm, reference, and control fuses are located in the left center section of the power/ distribution bays, power only bays, and distribution only bays. These fuses are not available for customer connected loads. Note also that distribution fuses also contain alarm-type fuses as detailed in the previous sections of this document.

Ordering Notes

- 1) Order replacement fuses as required per Table 7.

Assembly	Desig.	Function	Size (Amperes)	Type	Part No.
Power/Distribution Bays	F1	Distribution Bus Monitoring Circuit Cards Input Power (Bus #1 and #2)	3	Bussmann	248610900
	F2	Touch Screen PC Input Power	1-1/3	Bussmann	248610700
	--	Safety Fuse Cover	--	Bussmann GMT-X	248898700
Power Only Bays	F1	not used	--	--	--
	F2	Touch Screen PC Input Power	1-1/3	Bussmann	248610700
	--	Safety Fuse Cover	--	Bussmann GMT-X	248898700
Distribution Only Bays	F1	CAN Interface Circuit Card Input Power	3	SAN-O AX-1	248609200
	F2	Distribution Bus Monitoring Circuit Cards Input Power (Bus #1 and #2)	3	SAN-O AX-1	248609200
	F3	Distribution Bus Monitoring Circuit Cards Input Power (Bus #3 and #4)	3	SAN-O AX-1	248609200
	--	Safety Fuse Cover	--	SAN-O SAX-1	248898600
Distribution Fuseholder Alarm Fuse	FA	Fuse Alarm	18/100A	Bussmann GMT-18/100A	248610301
	--	Safety Fuse Cover	--	Bussmann GMT-X	248898700

Table 7
Replaceable Alarm, Reference, and Control Fuses

Input and Alarm Fuse on Optional Bullet Nose-Type 10-Position GMT Fuse Module, P/N 509128

Features

- ◆ Located on the optional bullet nose-type 10-position GMT fuse module (P/N 509128) is an input fuse. If this fuse opens, an alarm type fuse also opens to activate the fuse alarm circuit. The alarm-type fuse is located in fuse position #11 on the fuse module.

Restrictions

These fuses are not available for customer connected loads.

Ordering Notes

- 1) Order replacement fuses as required per Table 8.

Ampere Rating	Part Number
35	110982
0.18	248610301
Safety Fuse Cover (Bussmann GMT-Y)	102774

Table 8
Replacement Input Fuse and Associated Alarm Fuse on
Bullet Nose-Type 10-Position GMT Fuse Module P/N 509128

Optional Power/Distribution Bay Internal Ground Busbar Kits

Optional Internal Ground Busbar Kit (P/N 554862)

Features

- ◆ Provides one (1) internal ground busbar kit, which mounts inside a power/distribution bay between the two top distribution load busbars.
- ◆ Provides for installation of customer provided two-hole lugs with 1/4" clearance holes on 5/8" centers.
- ◆ Provides for installation of customer provided two-hole lugs with 3/8" clearance holes on 1" centers.

Restrictions

FACTORY INSTALLED ONLY.

Recommended for use with >100A distribution devices.

Rated for 2000 amperes per busbar.

All lugs for customer connections must be ordered separately.

Customer needs to supply lug mounting bolts and hardware.

Ordering Notes

- 1) Order internal ground busbar kit, P/N 554862, as required.
- 2) Factory to supply busbar mounting hardware as required.

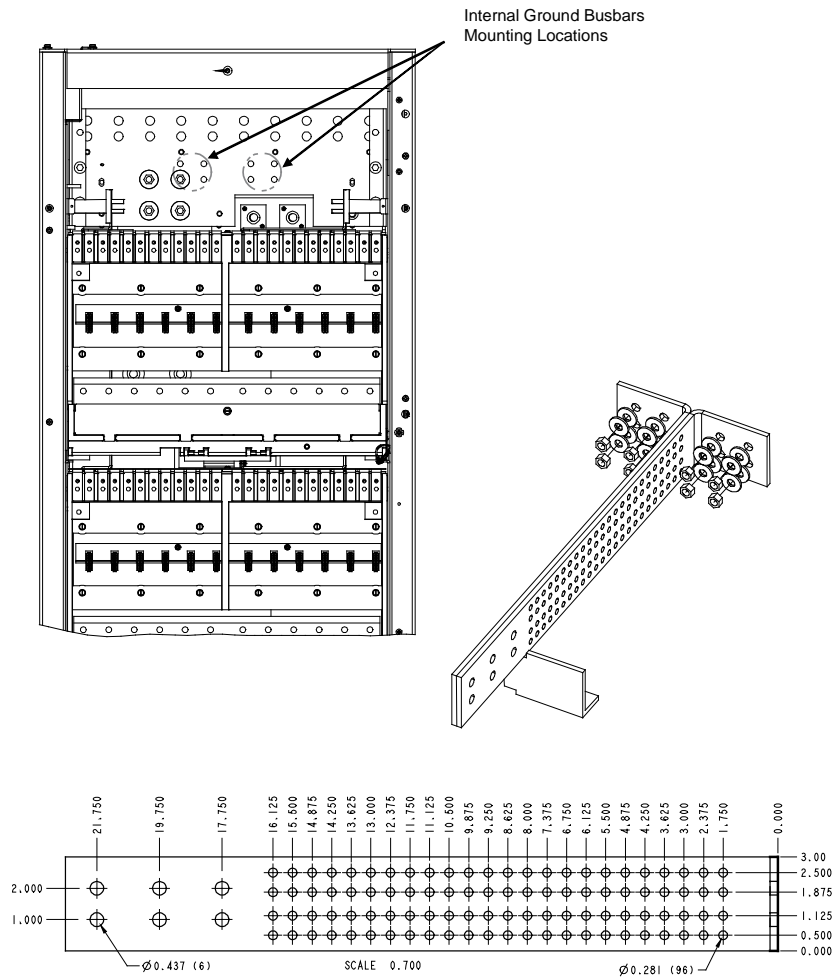

Internal Ground Busbar Assembly P/N 554862

Optional Internal Ground Busbar Kit (P/N 555214)

Features

- ◆ Provides one (1) internal ground busbar kit, which mounts inside a power/distribution bay between the two top distribution load busbars.
- ◆ Provides for installation of customer provided two-hole lugs with 1/4" clearance holes on 5/8" centers.
- ◆ Provides for installation of customer provided two-hole lugs with 3/8" clearance holes on 1" centers.

Restrictions

FACTORY INSTALLED ONLY.

Recommended for use with >300A distribution devices.

Rated for 2000 amperes per busbar.

All lugs for customer connections must be ordered separately.

Customer needs to supply lug mounting bolts and hardware.

Ordering Notes

- 1) Order internal ground busbar kit, P/N 555214, as required.
- 2) Factory to supply busbar mounting hardware as required.

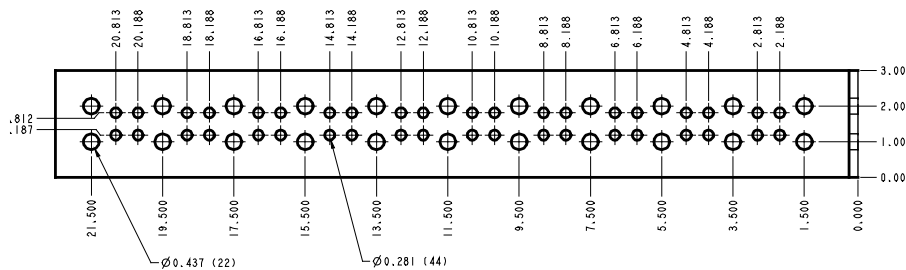
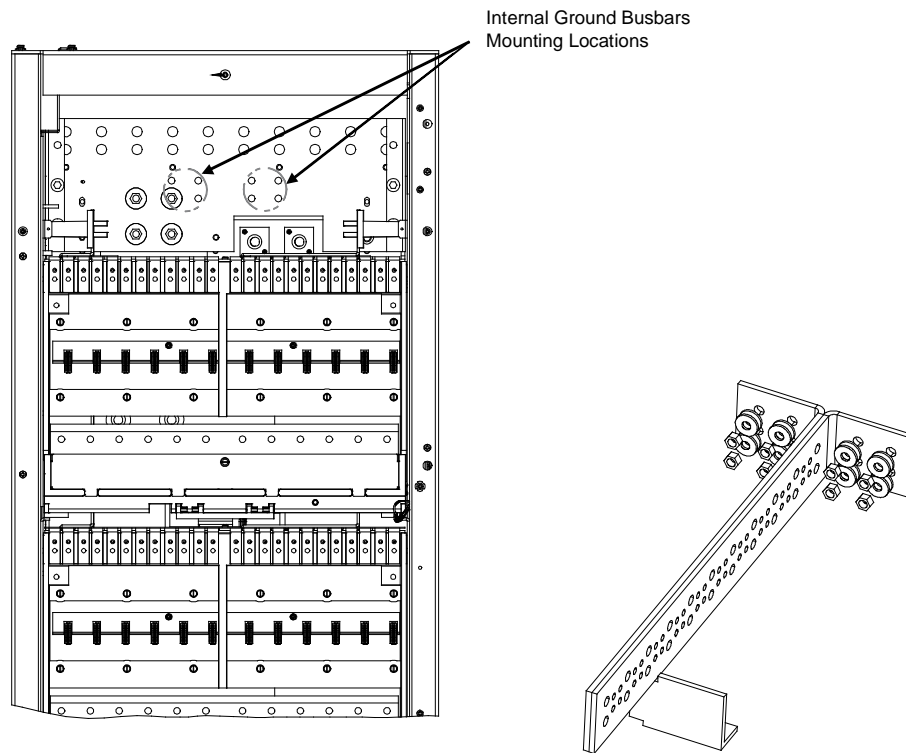

Internal Ground Busbar Assembly P/N 555214

Power/Distribution and Power Only Bays External Busbars

Optional External Top-Mount Horizontal Battery Input Busbar Assembly

Features

- ◆ Provides a battery input busbar assembly which mounts to the top of the bay.
- ◆ Provides horizontal lug landings for installation of customer provided two-hole lugs with 3/8" clearance holes on 1" centers.

Restrictions

Rated for 2000 amperes.

All lugs for customer connections must be ordered separately.

Customer needs to supply lug mounting bolts and hardware.

Not available when optional P/N 554874 external top-mount vertical battery input busbar assembly is installed. Bay will accept one or the other; not both.

Ordering Notes

- 1) Order an external top-mount horizontal battery input busbar assembly per bay as required, P/N 554873.

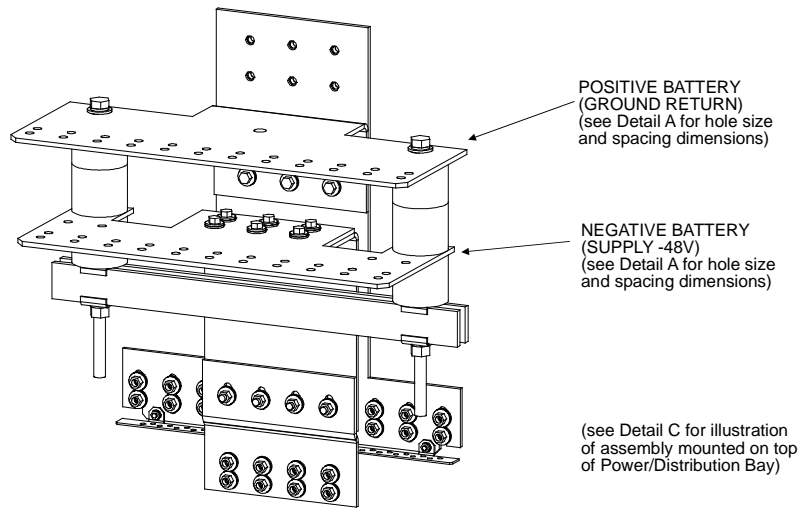

External Top-Mount Battery Input Busbar Assembly (P/N 554873)

Optional Busbar Shield Kit

Features

- ◆ Provides a plastic shield which mounts below the "Negative Battery (Supply -48V)" busbar on the external top-mount battery input busbar assembly P/N 554873.

Restrictions

Requires the external top-mount battery input busbar assembly P/N 554873.

Ordering Notes

- 1) Order a busbar shield kit (P/N 528482) as required for each external top-mount battery input busbar assembly ordered.

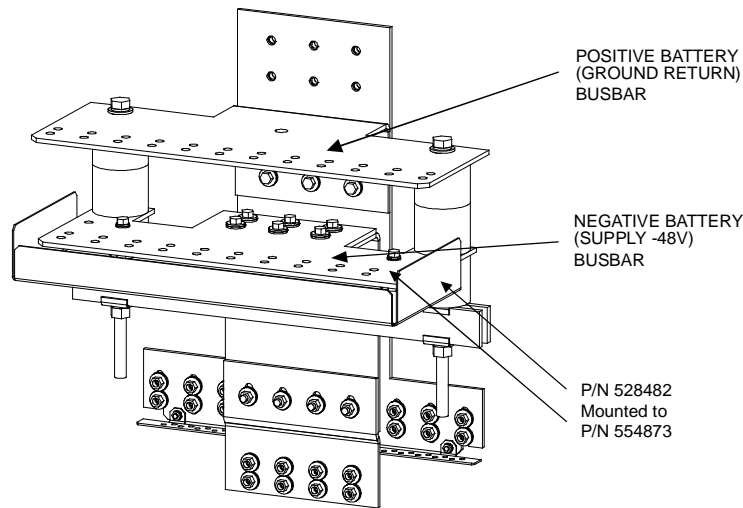

Busbar Shield Kit (P/N 528482)

Optional External Top-Mount Ground (Load Return) Busbar Assemblies

Features

- ◆ Provides a ground busbar assembly which mounts to the external top-mount battery input busbar assembly P/N 554873.
- ◆ Provides for installation of customer provided two-hole lugs with 3/8" clearance holes on 1" centers.

Restrictions

Requires the external top-mount battery input busbar assembly P/N 554873.

All lugs for customer connections must be ordered separately.

Customer needs to supply lug mounting bolts and hardware.

Ordering Notes

- 1) Order an external top-mount ground (load return) busbar assembly per bay as required.
 - P/N 514688, 6000A, for use with List 101 and List 111 (no PDSC [AC Input 'Power Distribution Service Cabinet']) or List 103, List 104, List 105, List 113, List 114, and List 115.
 - P/N 514689, 10000A, for use with List 101 and List 111 (no PDSC [AC Input 'Power Distribution Service Cabinet']) or List 103, List 104, List 105, List 113, List 114, and List 115.
 - P/N 514690, 6000A, for use with List 102 and List 112 equipped with a List 130 or List 131 PDSC (AC Input 'Power Distribution Service Cabinet').
 - P/N 514691, 10000A, for use with List 102 and List 112 equipped with a List 130 or List 131 PDSC (AC Input 'Power Distribution Service Cabinet').

Vertiv™ NetSure™ 8200 -48 VDC Power System

System Application Guide

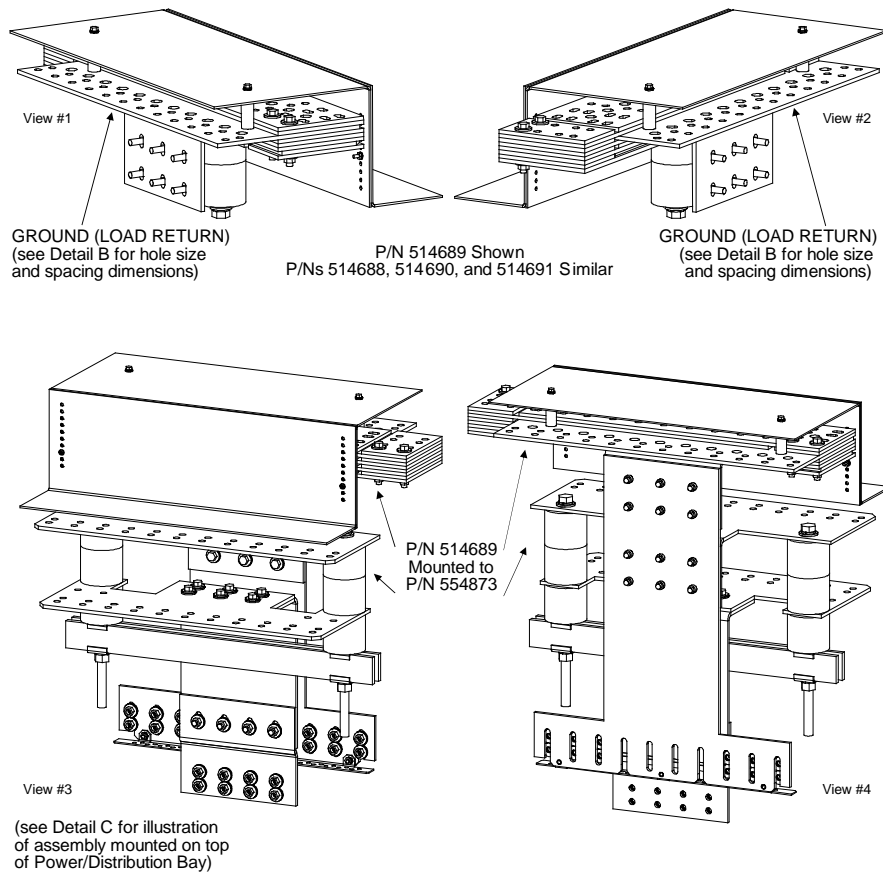

External Top-Mount Ground (Load Return) Busbar Assemblies (for use with External Top-Mount Battery Input Busbar Assembly P/N 554873)

P/N 514688 (6000A) (for use with List 101 and 111, no PCU AC Input Service Cabinet, or List 103, 104, 105, 113, 114, or 115)

P/N 514689 (10000A) (for use with List 101 and 111, no PCU AC Input Service Cabinet, or List 103, 104, 105, 113, 114, or 115)

P/N 514690 (6000A) (for use with List 102 and 112 e/w List 130 or 131 PCU AC Input Service Cabinet)

P/N 514691 (10000A) (for use with List 102 and 112 e/w List 130 or 131 PCU AC Input Service Cabinet)

Optional Load Return Lug Extension Busbar Assembly

Features

- ◆ Provides a load return lug extension busbar which mounts to an external top-mount ground (load return) busbar assembly.
- ◆ Provides for installation of customer provided two-hole lugs with 3/8" clearance holes on 1" centers.

Restrictions

Rated for 1000 amperes.

Requires an external top-mount ground (load return) busbar assembly; P/N 514688, 514689, 514690, or 514691.

All lugs for customer connections must be ordered separately.

Customer needs to supply lug mounting bolts and hardware.

Ordering Notes

- 1) Order a load return lug extension busbar assembly per bay as required, P/N 514543.

Vertiv™ NetSure™ 8200 -48 VDC Power System
System Application Guide

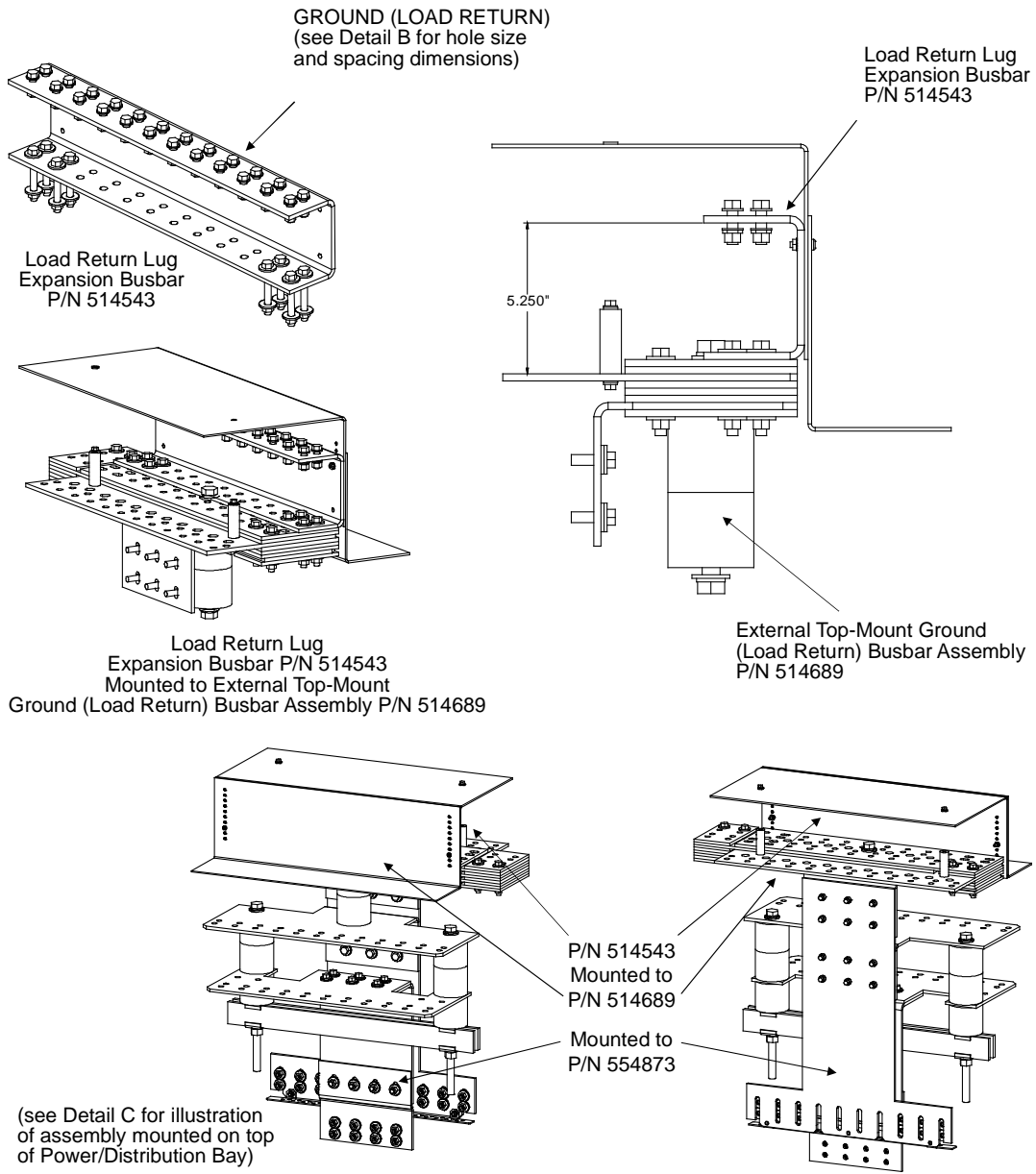

Load Return Lug Extension Busbar P/N 514543
(mounts to External Top-Mount Ground [Load Return] Busbar Assembly)

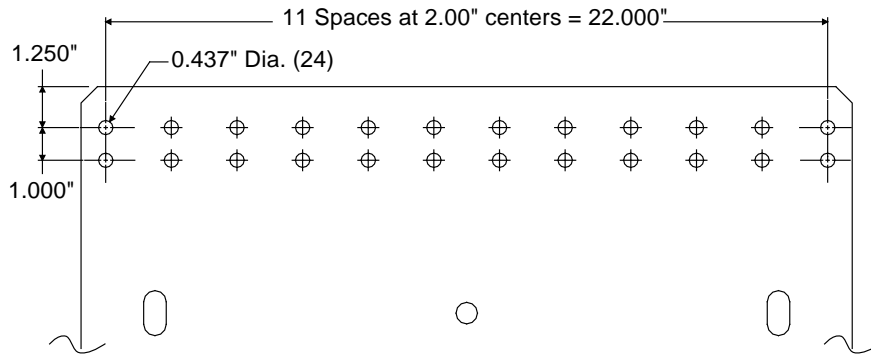

Detail A
 Positive and Negative Battery Busbars
 Hole Size and Spacing Dimensions
 (for installation of customer provided two-hole
 lugs with 3/8" clearance holes on 1" centers)

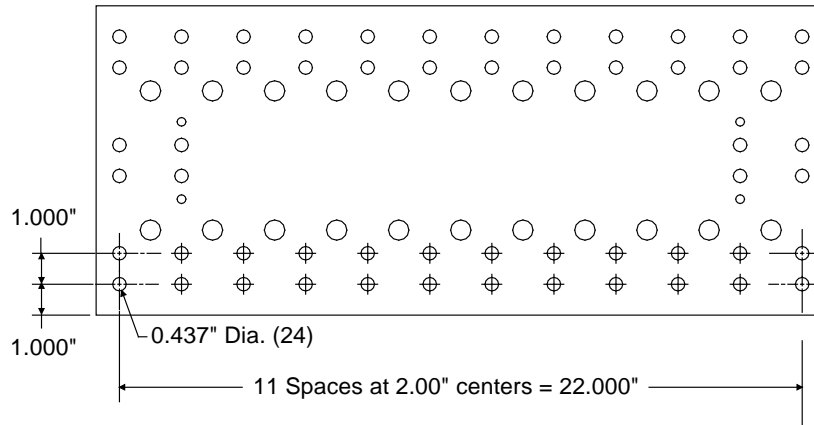

Detail B
 Load Return Busbars
 Hole Size and Spacing Dimensions
 (for installation of customer provided two-hole
 lugs with 3/8" clearance holes on 1" centers)

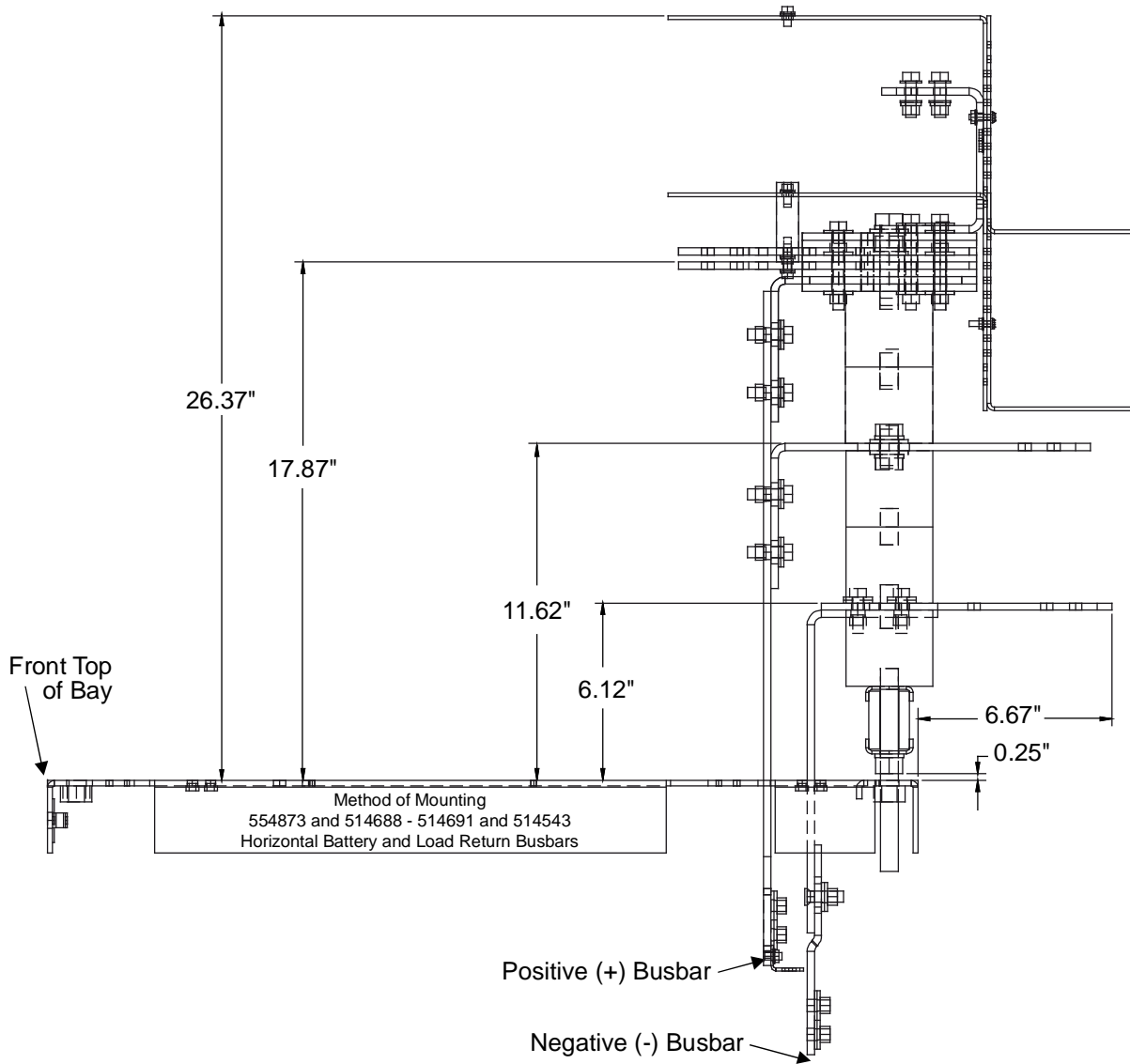

Detail C (cont'd on next page)
Busbar Assemblies
Mounted On Top of
Power/Distribution Bay

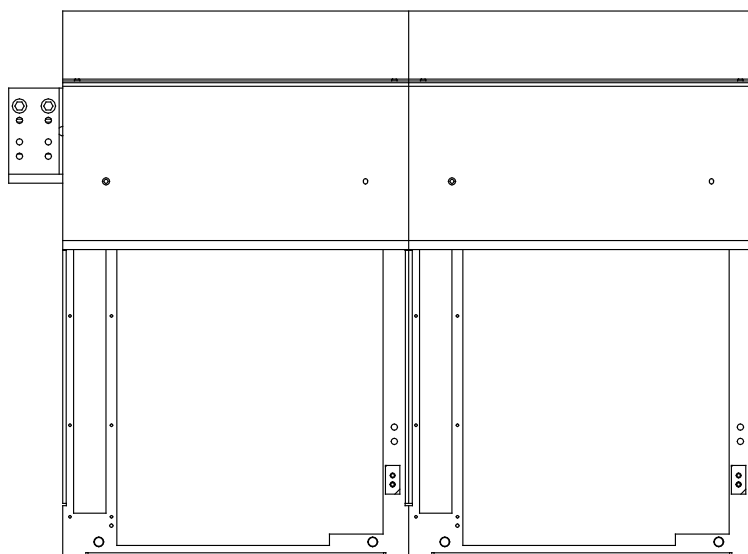

Top View
Expansion Bay
Ground Bar Mounting
P/N 514688 - 614689

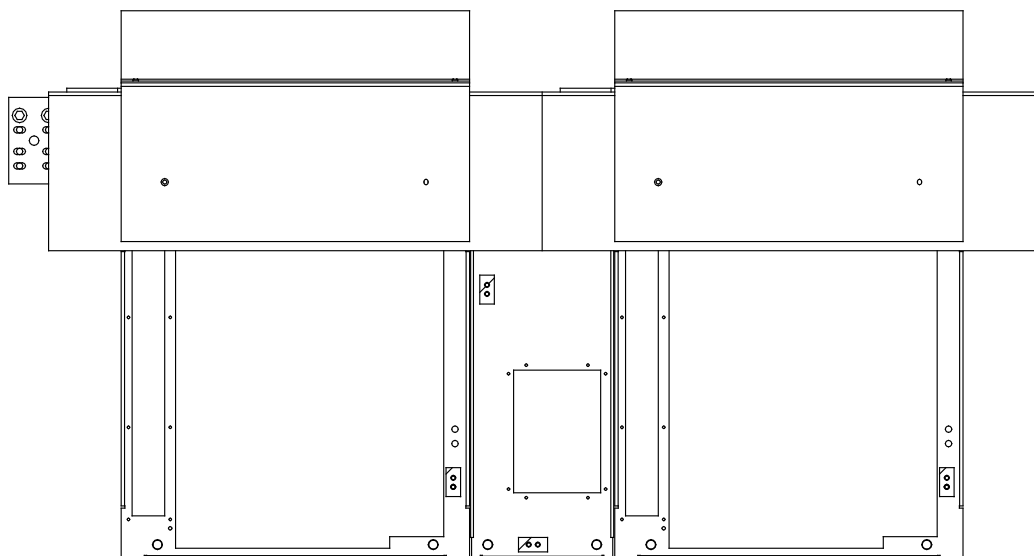

Top View
Expansion Bay
Ground Bar Mounting
P/N 514690 - 614691

Detail C (cont'd from previous page)
Busbar Assemblies
Mounted On Top of
Power/Distribution Bay

Optional External Top-Mount Vertical Battery Input Busbar Assembly

Features

- ◆ Provides a battery input busbar assembly that mounts to the top of the bay.
- ◆ Provides vertical lug landings for installation of customer provided two-hole lugs with 3/8" clearance holes on 1" centers.
- ◆ Includes a plastic shield that mounts below and behind the "Negative Battery (Supply -48V)" busbar.

Restrictions

Rated for 2000 amperes.

All lugs for customer connections must be ordered separately.

Customer needs to supply lug mounting bolts and hardware.

Not expandable.

Not available when optional P/N 554873 external top-mount horizontal battery input busbar assembly is installed. Bay will accept one or the other; not both.

Ordering Notes

- 1) Order one (1) external top-mount vertical battery input busbar assembly per bay as required, P/N 554874.

External Top-Mount Vertical Battery Input Busbar Assembly, P/N 554874

VIEW WITH BUSBAR SHIELD REMOVED

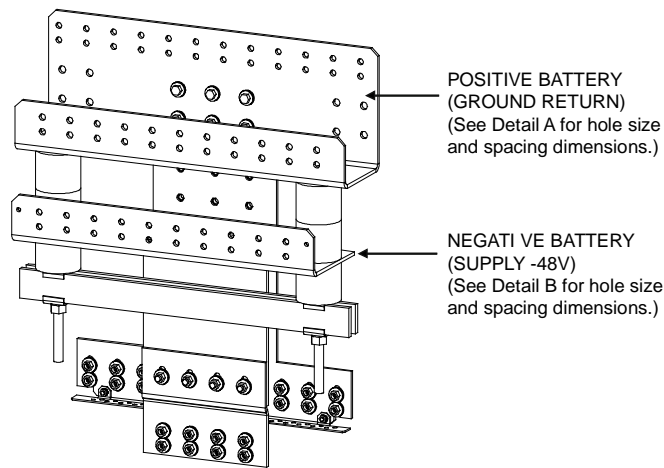

VIEW WITH BUSBAR SHIELD REMOVED

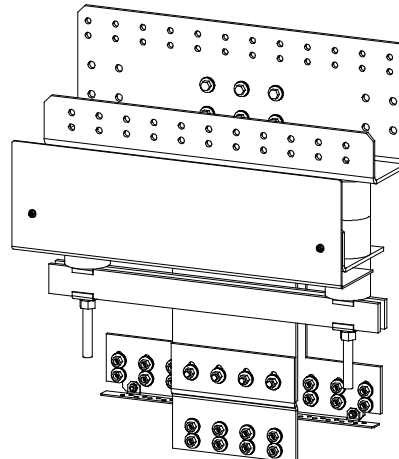

External Top-Mount Vertical Battery Input Busbar Assembly, P/N 554874

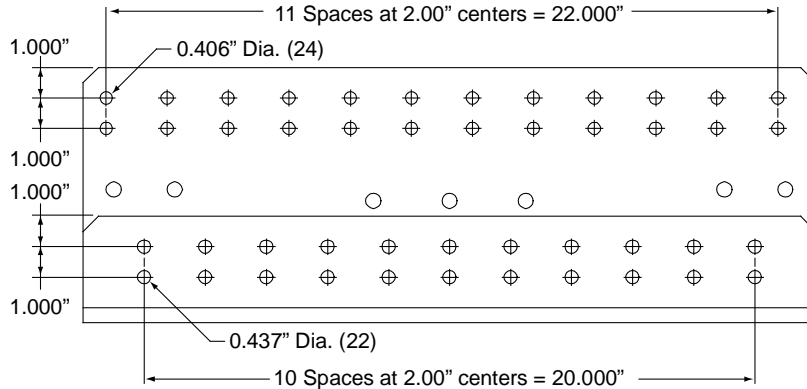

Detail A
Positive Battery Busbar
Hole Size and Spacing Dimensions
 (for installation of customer provided two-hole lugs with 3/8" clearance holes on 1" centers)

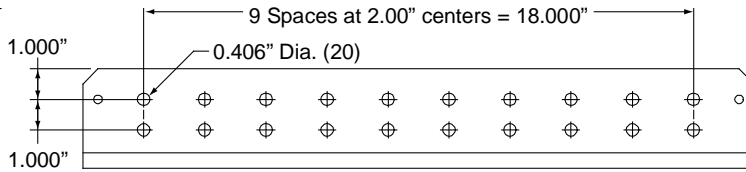

Detail B
Negative Battery Busbar
Hole Size and Spacing Dimensions
 (for installation of customer provided two-hole lugs with 3/8" clearance holes on 1" centers)

External Top-Mount Vertical Battery Input Busbar Assembly, P/N 554874

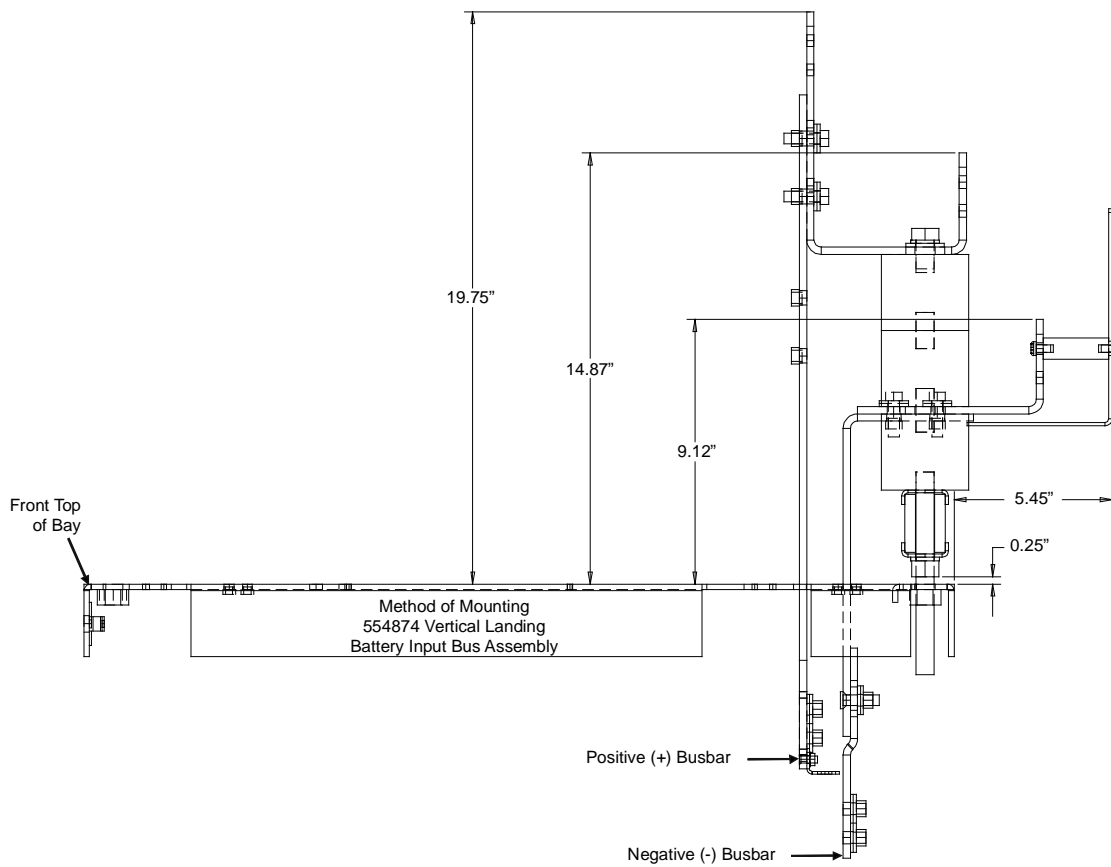

Detail C
554874 Battery Input Busbar Assembly
Mounted on Top of Power/Distribution Bay

Optional Temperature Probes (List 101, 102, 103, 104, 105 Only)

Features

- ◆ Up to two (2) temperature probes can be connected to the IB2 (NCU Interface Board). Up to two (2) temperature probes can be connected to the EIB (NCU Extended Interface Board). Up to ten (10) temperature probes can be connected to the SM-DUE. Any combination of the temperature probes can be programmed to monitor ambient temperature and/or battery temperature. A temperature probe set to monitor battery temperature can also be used for the rectifier battery charge temperature compensation feature, or the battery charge temperature compensation feature can be programmed to use the average or highest value of all battery temperature probes. The battery charge temperature compensation feature allows the controller to automatically increase or decrease the output voltage of the system to maintain battery float current as battery temperature decreases or increases, respectively. Battery life can be extended when an optimum charge voltage to the battery with respect to temperature is maintained. A temperature probe set to monitor battery temperature can also be used for the BTRM (Battery Thermal Runaway Management) feature. The BTRM feature lowers output voltage when a high temperature condition exists to control against battery thermal runaway.
- ◆ The temperature sensor end of the probe contains a tab with a 5/16" clearance hole for mounting.
- ◆ Temperature probes can also be used with the optional [SM-Temp Temperature Concentrator](#).

Restrictions

A temperature probe programmed to monitor battery temperature should be mounted on the negative post of a battery cell to sense battery temperature. A temperature probe used for battery charge temperature compensation or BTRM (Battery Thermal Runaway Management) should also be mounted on the negative post of a battery cell. A temperature probe programmed to monitor ambient temperature should be mounted in a convenient location, away from direct sources of heat or cold.

Ordering Notes

- 1) Order temperature probes as required. Note that each temperature probe consists of two or three pieces which plug together to make a complete probe (see the following illustration). For a complete temperature probe, order one (1) P/N 552992 (10.3 meters) or one (1) P/N 556155 (3.3 meters). If additional length is required, order temperature probe extension cable P/N 04119122 (10 meters). See also "Optional Temperature Probes" on page 121.
- 2) If more probes are desired, order one or more SM-Temp Temperature Concentrator, P/N 547490. See "Optional SM-Temp Temperature Concentrator, P/N 547490" next.

Optional SM-Temp Temperature Concentrator, P/N 547490

Features

- ◆ Allows for multiple temperature probes to be used for ambient temperature monitoring, battery temperature monitoring, temperature compensation, and/or BTRM (Battery Thermal Runaway Management).
- ◆ Provides (8) temperature probe inputs per SM-Temp.
- ◆ Can cascade up to (8) SM-Temp modules, connecting up to sixty-four (64) temperature probes.
- ◆ The SM-Temp Concentrator is connected at the end of the NCU CAN bus. Via the CAN Bus, the NCU reads each temperature probe from each SM-Temp Concentrator.

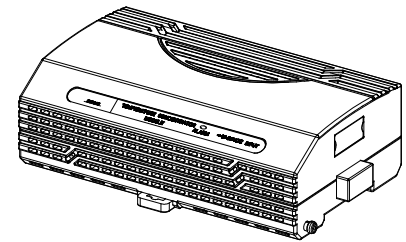

Ordering Notes

- 1) Order SM-Temp Temperature Concentrator, P/N 547490, as required.
- 2) Order up to (8) temperature probes for each concentrator. See "Optional Temperature Probes (List 101, 102, 103, 104, 105 Only)" above.

Optional SM-IO2, P/N 02440103

Features

- ◆ Consists of an SM-DUE enclosed in a sheet metal housing.
- ◆ Used in applications where an SM-DUE is mounted external to a power system equipped with an NCU controller.
- ◆ Used to input external monitoring information to the NCU controller.
- ◆ Provides the following monitoring inputs:
Ten (10) input blocks with each providing the following monitoring inputs:
 - One (1) Load Bus Voltage (0 VDC to 60 VDC) per input block.
 - One (1) Load Fuse Alarm (Bus- base of 0 VDC, >10 VDC alarm, <10 VDC normal) per input block.
 - One (1) Programmable Analog Input, can be set to accept one (1) of the following inputs per input block:
10 mV DC to 50 mV DC Load Shunt (only load shunts are supported at this time).
General-Purpose Current Transducer.
General-Purpose Voltage Transducer.
1 uA/K Temperature Sensor.
- ◆ Also contains a +5 VDC power supply output for connection to external Hall devices.
- ◆ The SM-DUE connects into the NCU CAN bus.

Restrictions

Up to eight (8) SM-DUE units can be connected to an NCU.

Ordering Notes

- 1) Order SM-IO2 units as required (P/N 02440103).
- 2) Order one (1) termination resistor (P/N 561768) for the last SM-IO2 in the NCU CAN bus (or if there is only one SM-IO2 installed).

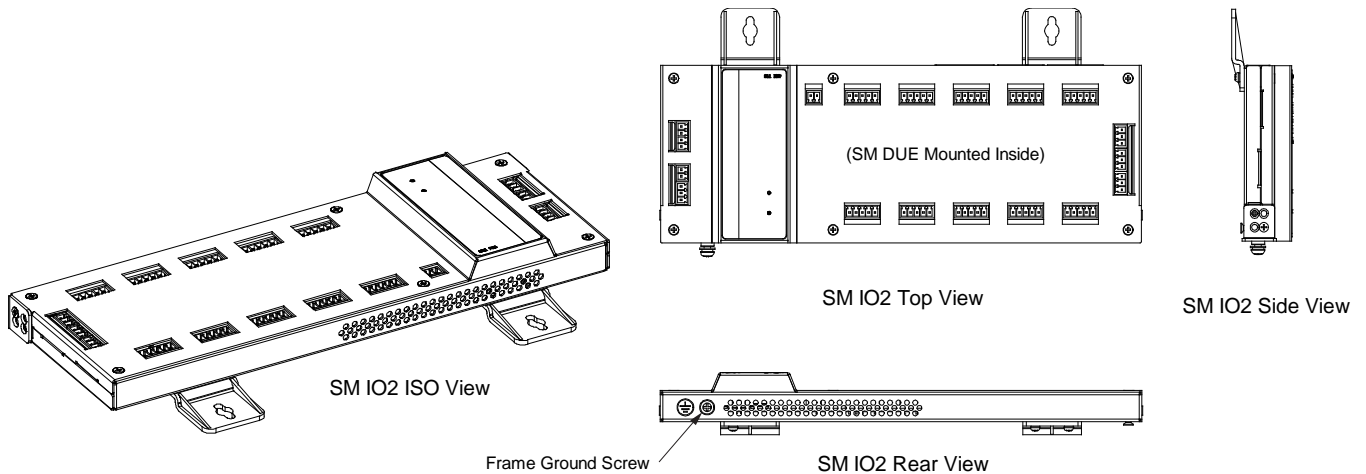

Optional SM-DU+, P/N 10010507

Features

- ◆ Consists of an SM-DU+ enclosed in a sheet metal housing.
- ◆ Used in applications where an SM-DU+ is mounted external to a power system equipped with an NCU controller.
- ◆ Used to connect load shunts and fuse alarm signals to the NCU controller.
- ◆ Provides twenty-five (25) load shunt monitoring inputs and fourteen (14) fuse alarm monitoring inputs.
- ◆ The SM-DU+ connects into the NCU CAN bus.
- ◆ Contains one (1) termination resistor (P/N 561768). Required for the last SM-DU+ in the NCU CAN bus (or if there is only one SM-DU+ installed).

Restrictions

Up to eight (8) SM-DU+ units can be connected to an NCU.

Ordering Notes

- 1) Order SM-DU+ units as required (P/N 10010507).

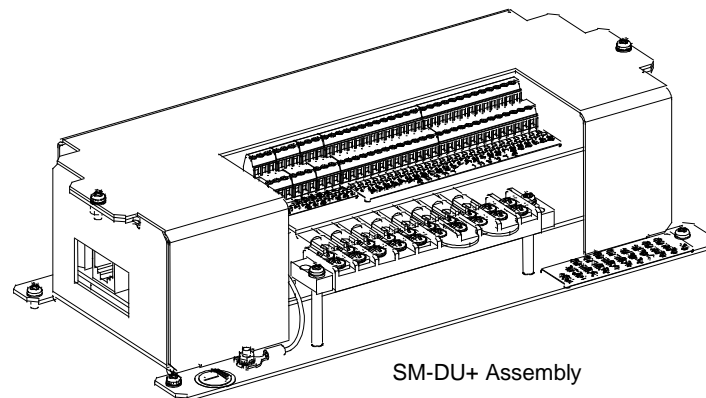

Replacement/Additional Network Cable (List 111, 112, 113, 114, 115, 116, 117, 118, 122 Only)

Features

- ◆ Controller bay-to-bay interconnect cable. Connects between bay expansion ports located on the bay's controller (Primary Bay) and Router / CAN Interface (Secondary Bays) circuit cards.

Restrictions

Maximum combined cable length must not exceed 125 feet.

Ordering Notes

- 1) For a replacement or additional cable, order the proper length cable from those listed below.
- 2) P/N 524409 (5 inches)
P/N 509070 (6 inches)
P/N 528520 (10 inches)
P/N 509071 (15 inches)
P/N 524410 (2 feet)
P/N 514639 (3 feet)
P/N 509900 (4 feet)
P/N 514640 (25 feet)
P/N 514641 (150 feet)

Primary Bay NCU Retrofit Kit, P/N 565406

Features

- ◆ This kit replaces the front door and control shelf in an existing List 01, 02, 03, 04, or 05 primary bay with the kit supplied front door and control shelf (as in a List 101, 102, 103, 104, or 105 primary bay).

Restrictions

For systems where the MCA (Meter, Control, Alarm Panel) and optional LMS monitoring system are being replaced with the NCU controller.

For use in primary bay List 01, 02, 03, 04, 05 only.

Field installed.

Ordering Notes

- 1) Order P/N 565406 to upgrade an existing List 01, 02, 03, 04, 05 primary bay with the NCU controller.

Secondary Bay NCU Retrofit Kit, P/N 565408

Features

- ◆ This kit replaces the control shelf in an existing List 11, 12, 13, 14, or 15 secondary bay with the kit supplied control shelf (as in a List 111, 112, 113, 114, or 115 secondary bay).

Restrictions

For systems where the MCA (Meter, Control, Alarm Panel) and optional LMS monitoring system are being replaced with the NCU controller.

For use in secondary bay List 11, 12, 13, 14, 15 only.

Field installed.

Ordering Notes

- 1) Order P/N 565408 to upgrade an existing List 11, 12, 13, 14, 15 secondary bay with the NCU controller.

Distribution Only Bay NCU Retrofit Kit, P/N 566156

Features

- ◆ This kit replaces the control shelf in an existing "Newer Style" List 16 distribution only bay with the kit supplied control shelf (as in a List 116 distribution only bay).

Restrictions

For systems where the MCA (Meter, Control, Alarm Panel) and optional LMS monitoring system are being replaced with the NCU controller.

Vertiv™ NetSure™ 8200 -48 VDC Power System

System Application Guide

For use in a “Newer Style” List 16 distribution only bay. See Figure 1 for an illustration of the “Newer Style” Bay. Field installed.

Ordering Notes

- 1) Order P/N 566156 to upgrade an existing “Newer Style” List 16 distribution only bay with the NCU controller.

Distribution Only Bay NCU Retrofit Kit, P/N 566157

Features

- ◆ This kit replaces the control shelf in an existing “Older Style” List 16 distribution only bay with the kit supplied control shelf.
- ◆ This kit replaces the control shelf in an existing List 17, 18, or 22 distribution only bay with the kit supplied control shelf (as in a List 117, 118, or 122 distribution only bay).

Restrictions

For systems where the MCA (Meter, Control, Alarm Panel) and optional LMS monitoring system are being replaced with the NCU controller.

For use in an “Older Style” List 16 distribution only bay. See Figure 2 for an illustration of the “Older Style” Bay. Also for use in a List 17, 18, 22 distribution only bay.

Field installed.

Ordering Notes

- 1) Order P/N 566157 to upgrade an existing “Older Style” List 16 distribution only bay with the NCU controller.
- 2) Order P/N 566157 to upgrade an existing List 17, 18, 22 distribution only bay with the NCU controller.

Newer Style 582140000 List 16 Bay

Use Kit P/N 566156

(for an older style bay, use kit P/N 566157)

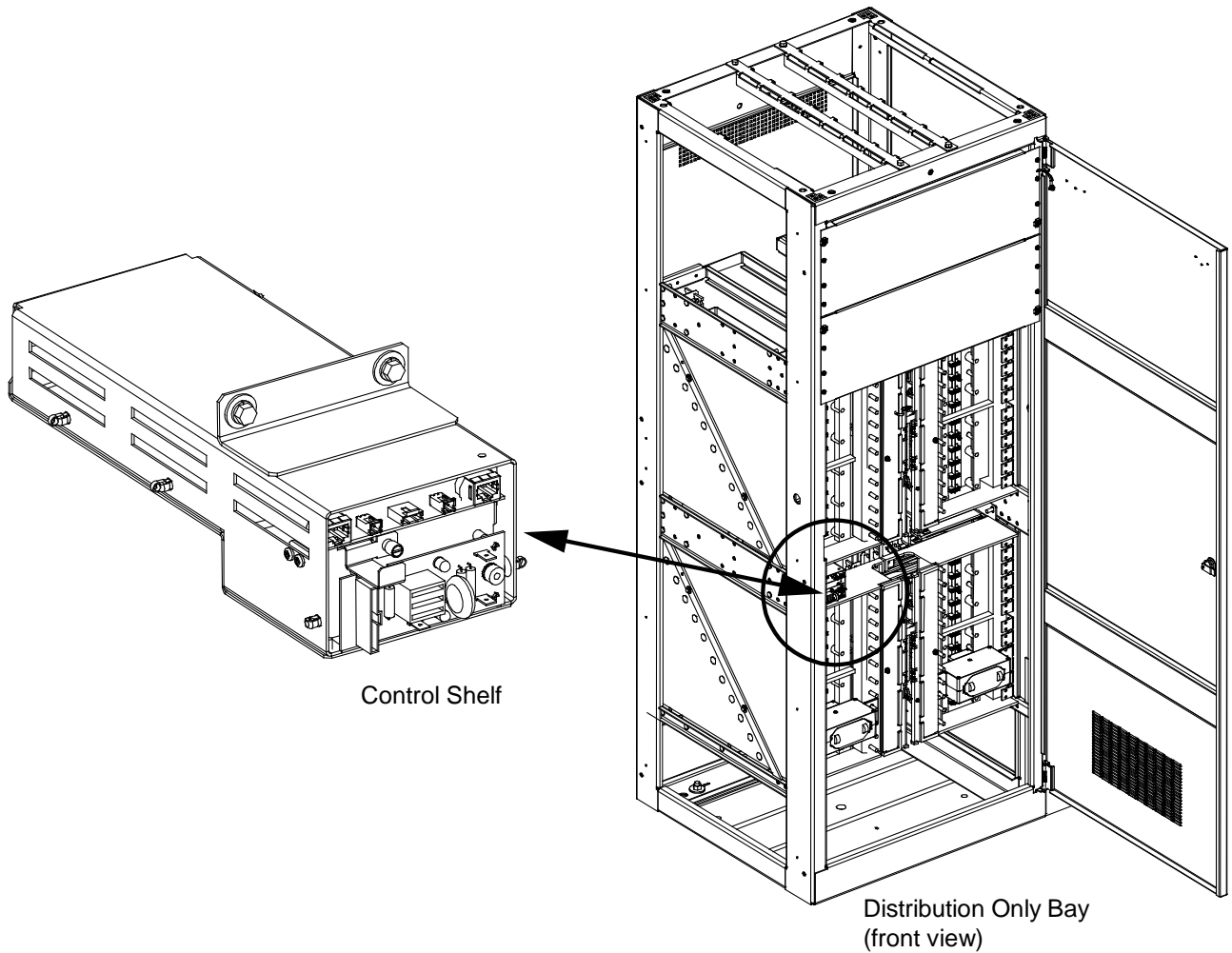

Figure 1
Newer Style 582140000 List 16 Distribution Only Bay

Older Style 582140000 List 16 Bay Use Kit P/N 566157 (for a newer style bay, use kit P/N 566156)

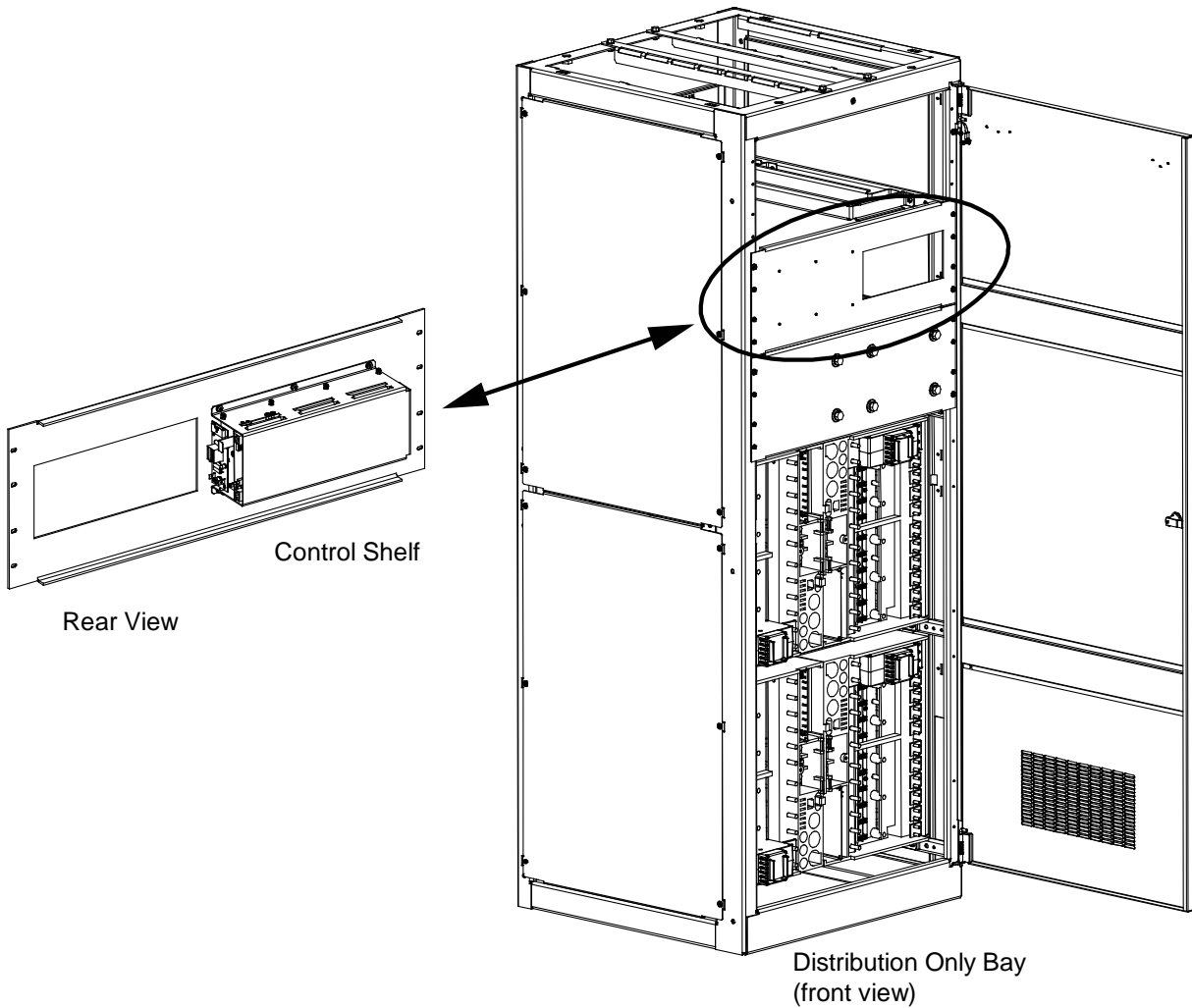

Figure 2
Older Style 582140000 List 16 Distribution Only Bay

User Replaceable Components

Models 8200NLDB, 8200NLEB and 8200NL-B

- 1) Rectifier: P/N 486532603 or P/N 486534003.
- 2) NCU Controller (Primary Power Bay): 1M830BNA565806.
- 3) NCU IB2 Interface Board: 555286 (Assembly), MA4C5U31 (Board Only).
- 4) NCU EIB Extended Interface Board: 548120 (Assembly), MA455U41 (Board Only).
- 5) NCU IB5 Interface Board: 559741 (Assembly), 10146319 (Board Only).
- 6) CAN Interface Circuit Card: 566014.
- 7) SM-DUE: ROA1190937/1.
- 8) Distribution Monitoring Circuit Card: P/N 524982.

Wiring Components

Power/Distribution and Power Only Bays Frame Grounding Wire Sizes and Lugs

Features

- ◆ Two sets of captive nuts (1/4-20 on 5/8" centers) are provided for installation of customer provided two-hole lugs.
- ◆ For lug mounting hole size and spacing dimensions, refer to the illustration provided in this section.

Restrictions

All lugs for customer connections must be ordered separately.

Customer needs to supply lug mounting bolts and hardware.

The recommended frame ground wire size is 6 AWG.

Recommended lug P/N 245346700.

Two holes with 1/4-20 captive nuts provided for installation of customer provided two-hole lug with 1/4" bolt clearance holes on 5/8" centers

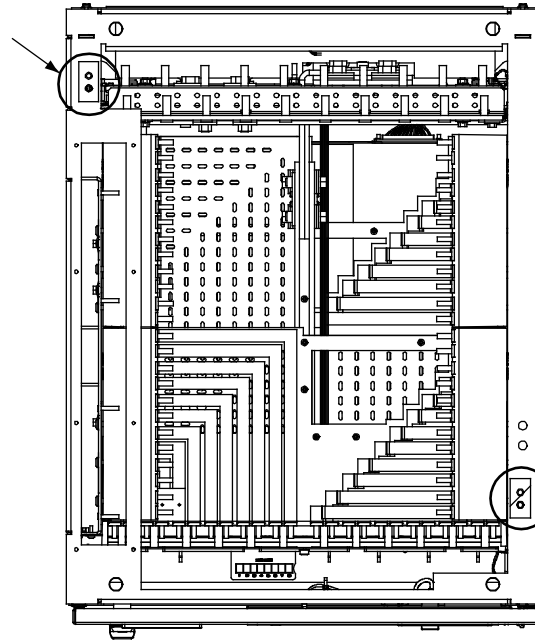

Two holes with 1/4-20 captive nuts provided for installation of customer provided two-hole lug with 1/4" bolt clearance holes on 5/8" centers

Top View
Power/Distribution Bays
(Power Only Bays Similar)

Distribution Only Bay Frame Grounding Wire Sizes and Lugs Selection

Features

- ◆ 1/4" clearance holes on 5/8" centers are provided for installation of customer provided two-hole lugs, as shown in the following illustration.

Restrictions

All lugs for customer connections must be ordered separately.

Customer needs to supply lug mounting bolts and hardware.

The recommended frame grounding wire size is 6 AWG.

Recommended lug P/N 245346700.

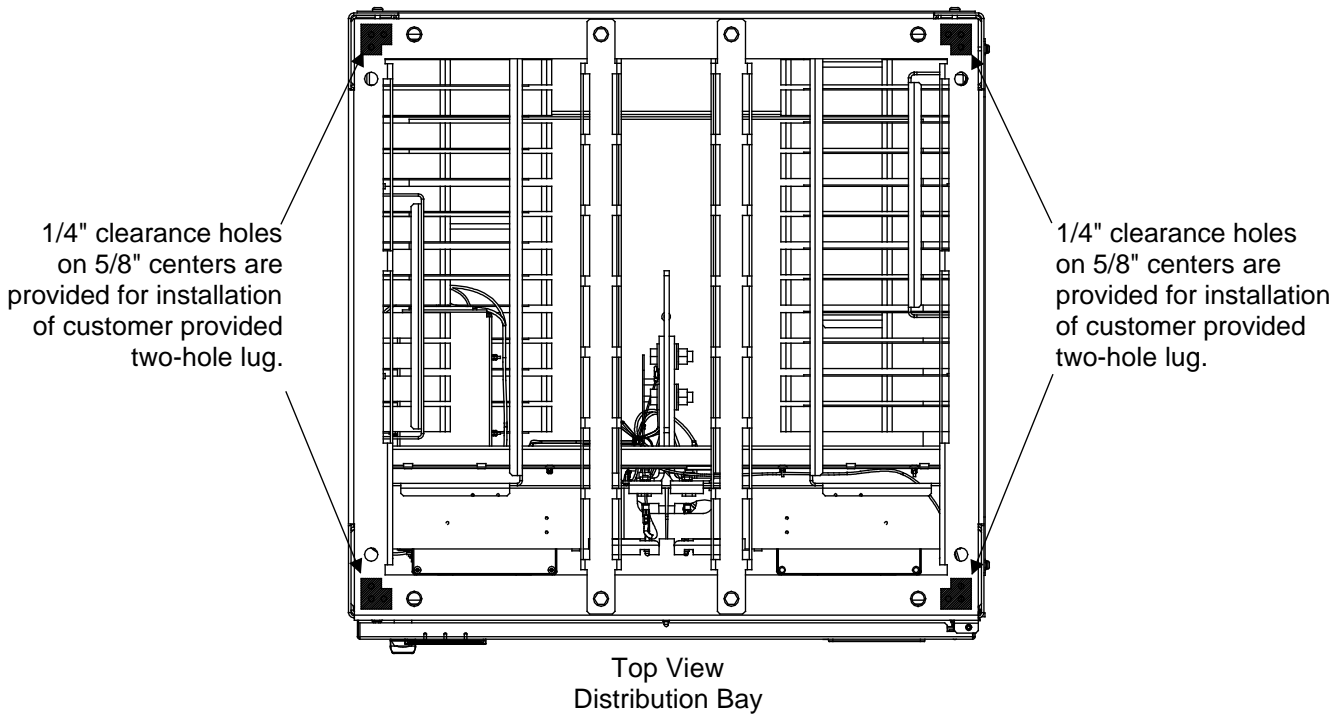

Power/Distribution Bay and Distribution Only Bay Load Distribution Wire Sizes and Lugs

Features

- ◆ Load distribution leads are connected as described in the sections titled [Distribution Devices and Load Lug Locations - Power/Distribution Bays](#) and [Distribution Device and Load Lug Locations – Distribution Only Bays](#) under "Accessory Descriptions". For lug mounting hole size and spacing dimensions, refer to the illustrations in these sections.

Restrictions

All lugs for customer connections must be ordered separately.

Ordering Notes

- 1) The type of distribution device determines the load lug hole size and spacing requirements. The rating of the distribution device determines the wire size requirements. For wire size and lug selection; refer to Tables [9](#) and [10](#) (Load Side). Load return leads for power/distribution bays are terminated either inside the bay if equipped with the optional internal ground busbar, or outside the bay if equipped with the optional external ground busbar mounted on top of the bay. Load return leads for distribution only bays are terminated outside the bay to customer provided return busbars.
- 2) Lugs should be crimped per lug manufacturer's specifications.

Vertiv™ NetSure™ 8200 -48 VDC Power System
System Application Guide

Fuse/Circuit Breaker Amperage	Recm 90°C Wire Size ⁽¹⁾						
	14 AWG	12 AWG	10 AWG	8 AWG	6 AWG	4 AWG	2 AWG
	Loop Length (feet) ⁽²⁾						
1, 3, 5, 6, 10A	37 ^(3,4)	58 ^(3,4)	93 ^(3,4)	--	--	--	--
15A	24 ^(3,4)	39 ^(3,4)	62 ^(3,4)	--	--	--	--
20A	--	29 ^(3,4)	46 ^(3,4)	74 ^(3,4)	--	--	--
25A	--	--	37 ^(3,4)	59 ^(3,4)	94 ^(3,4)	--	--
30A	--	--	31 ^(3,4)	49 ^(3,4)	78 ^(3,4)	--	--
35A	--	--	--	42 ^(3,4)	67 ^(3,4)	107 ^(3,4)	--
40A	--	--	--	37 ^(3,4)	59 ^(3,4)	94 ^(3,4)	--
45A	--	--	--	33 ^(3,4)	52 ^(3,4)	83 ^(3,4)	--
50A	--	--	--	29 ^(3,4)	47 ^(3,4)	75 ^(3,4)	--
60A	--	--	--	--	39 ^(3,4)	62 ^(3,4)	99 ^(3,4)
70A	--	--	--	--	33 ⁽³⁾	53 ^(3,4)	85 ^(3,4)
75A	--	--	--	--	31 ⁽³⁾	50 ^(3,4)	79 ^(3,4)
80A	--	--	--	--	--	47 ^(3,4)	74 ^(3,4)
90A	--	--	--	--	--	41 ⁽³⁾	66 ^(3,4)
100A	--	--	--	--	--	--	59 ^(3,4)
125A	Two Pole Devices. Use Load Lug Adapter Plate P/N 513700, Kit P/N 520891 (kit includes mtg. hardware) and select Wire Sizes and Lugs per Table 10 .						
150A							
200A							
250A	Three Pole Devices. Use Load Lug Adapter Plate P/N 514676, Kit P/N 534703 (kit includes mtg. hardware) and select Wire Sizes and Lugs per Table 10 .						
Recommended Crimp Lug ⁽⁵⁾							
Lug	245342300	245342300	245342300	245390200	245346700	245346800	245346900

- Wire sizes based on recommendations of the American National Standards Institute (ANSI) approved National Fire Protection Association's (NFPA) National Electrical Code (NEC). Table 310.15 (B) (16) for copper wire at 90°C conductor temperature. For operation in countries where the NEC is not recognized, follow applicable codes.
- Recommended wire sizes are sufficient to restrict voltage drop to 1.0 volt or less at listed branch current for the loop lengths shown. Loop length is the sum of the lengths of the positive and negative leads.
- Wire Size / Loop Length Combination Calculated using 30°C Ambient Operating Temperature.
- Wire Size / Loop Length Combination Calculated using 40°C Ambient Operating Temperature.
- Two-hole lug, 1/4" bolt clearance hole, 5/8" centers. Lugs should be crimped per lug manufacturer's specifications.

Table 9
Recommended Load Distribution Wire Size and Lug Selection for
TLS/TPS Fuse and Bullet Nose-Type Circuit Breaker (Load Side)

Vertiv™ NetSure™ 8200 -48 VDC Power System
System Application Guide

Fuse/ Circuit Breaker Amperage	Recm 90°C Wire Size ⁽¹⁾									
	6 AWG	4 AWG	2 AWG	1/0 AWG	2/0 AWG	3/0 AWG	4/0 AWG	250 kcmil	300 kcmil	350 kcmil
	Loop Length (feet) ⁽²⁾									
70A	33 ⁽³⁾	53 ^(3, 4)	85 ^(3, 4)	135 ^(3, 4)	--	--	--	--	--	--
80A	--	47 ^(3, 4)	74 ^(3, 4)	118 ^(3, 4)	--	--	--	--	--	--
100A	--	--	59 ^(3, 4)	95 ^(3, 4)	119 ^(3, 4)	--	--	--	--	--
125A	--	--	47 ⁽³⁾	76 ^(3, 4)	95 ^(3, 4)	120 ^(3, 4)	--	--	--	--
150A	--	--	--	63 ^(3, 4)	79 ^(3, 4)	100 ^(3, 4)	--	--	--	--
175A	--	--	--	--	68 ^(3, 4)	86 ^(3, 4)	108 ^(3, 4)	--	--	--
200A	--	--	--	--	--	75 ^(3, 4)	95 ^(3, 4)	112 ^(3, 4)	--	--
225A	--	--	--	--	--	67 ⁽³⁾	84 ^(3, 4)	100 ^(3, 4)	120 ^(3, 4)	--
250A	--	--	--	--	--	--	76 ⁽³⁾	90 ^(3, 4)	108 ^(3, 4)	126 ^(3, 4)
Recommended Crimp Lug ⁽⁵⁾										
Lug	2453- 49900	2453- 50000	2453- 48200	2453- 47100	2453- 47200	2453- 47300	2453- 47400	2453- 47500	2453- 47600	2453- 47700

- ¹ Wire sizes based on recommendations of the American National Standards Institute (ANSI) approved National Fire Protection Association's (NFPA) National Electrical Code (NEC). Table 310.15 (B) (16) for copper wire at 90°C conductor temperature. For operation in countries where the NEC is not recognized, follow applicable codes.
- ² Recommended wire sizes are sufficient to restrict voltage drop to 1.0 volt or less at listed branch current for the loop lengths shown. Loop length is the sum of the lengths of the positive and negative leads.
- ³ Wire Size / Loop Length Combination Calculated using 30°C Ambient Operating Temperature.
- ⁴ Wire Size / Loop Length Combination Calculated using 40°C Ambient Operating Temperature.
- ⁵ Two-hole lug, 3/8" bolt clearance hole, 1" centers. Lugs should be crimped per lug manufacturer's specifications.

Table 10 (cont'd on next page)
Recommended Distribution (Load) Wire Size and Lug Selection for
TPL Fuse and 218 Circuit Breaker (Load Side)

Vertiv™ NetSure™ 8200 -48 VDC Power System
System Application Guide

Fuse/ Circuit Breaker Amperage	Recm 90°C Wire Size ⁽¹⁾						
	2/0 AWG	3/0 AWG	4/0 AWG	250 kcmil	300 kcmil	350 kcmil	400 kcmil
	Loop Length (feet) ⁽²⁾						
300A	--	--	--	150 ^(3,4) (2) Wires	90 ⁽³⁾	105 ^(3,4)	120 ^(3,4)
350A	68 ^(3,4) (2) Wires	86 ^(3,4) (2) Wires	108 ^(3,4) (2) Wires	128 ^(3,4) (2) Wires	--	90 ⁽³⁾	103 ⁽³⁾
400A		75 ^(3,4) (2) Wires	95 ^(3,4) (2) Wires	112 ^(3,4) (2) Wires	--	--	--
450A	--	67 ⁽³⁾ (2) Wires	84 ^(3,4) (2) Wires	100 ^(3,4) (2) Wires	120 ^(3,4) (2) Wires	--	--
500A		--	76 ⁽³⁾ (2) Wires	90 ^(3,4) (2) Wires	108 ^(3,4) (2) Wires	126 ^(3,4) (2) Wires	--
600A		--	--	--	90 ⁽³⁾ (2) Wires 135 ^(3,4) (3) Wires	105 ^(3,4) (2) Wires	120 ^(3,4) (2) Wires
800A	--	--	--	84 ⁽³⁾ (3) Wires	101 ^(3,4) (3) Wires	118 ^(3,4) (3) Wires	135 ^(3,4) (3) Wires
Recommended Crimp Lug ⁽⁵⁾							
Lug	245347200 (per cable)	245347300 (per cable)	245347400 (per cable)	245347500 (per cable)	245347600 (per cable)	245347700 (per cable)	245347800 (per cable)

- ¹ Wire sizes based on recommendations of the American National Standards Institute (ANSI) approved National Fire Protection Association's (NFPA) National Electrical Code (NEC). Table 310.15 (B) (16) for copper wire at 90°C conductor temperature. For operation in countries where the NEC is not recognized, follow applicable codes.
- ² Recommended wire sizes are sufficient to restrict voltage drop to 1.0 volt or less at listed branch current for the loop lengths shown. Loop length is the sum of the lengths of the positive and negative leads.
- ³ Wire Size / Loop Length Combination Calculated using 30°C Ambient Operating Temperature.
- ⁴ Wire Size / Loop Length Combination Calculated using 40°C Ambient Operating Temperature.
- ⁵ Two-hole lug, 3/8" bolt clearance hole, 1" centers. Lugs should be crimped per lug manufacturer's specifications.

Table 10 (cont'd from previous page)
Recommended Distribution (Load) Wire Size and Lug Selection for
TPL Fuse and 218 Circuit Breaker (Load Side)

Power/Distribution Bay Battery Cable Sizes and Lugs

Features

- ◆ Studs (3/8-16 on 1" centers) are provided for installation of customer provided two-hole lugs. These studs are accessed from the rear of the each power/distribution bay. (Overhead busbars may be furnished. Refer to the section titled [Power/Distribution and Power Only Bays External Busbars](#) under "Accessory Descriptions" for battery lug selection.)
- ◆ For lug mounting hole size and spacing dimensions, refer to the illustration provided in this section.

Restrictions

All lugs for customer connections must be ordered separately.
 Customer needs to supply lug mounting hardware.

Ordering Notes

- 1) Battery cable size varies depending on load, therefore no specific information is provided for cable size. Refer to Table 11 for recommended cable sizes and lugs at rated maximum bay load (2400 amperes). When making connections, observe correct polarity.
- 2) Lugs should be crimped per lug manufacturer’s specifications.

Ambient Operating Temperature ⁽¹⁾	Loop Length ⁽²⁾ (Ft)	Recm 90°C Wire Size ^(1, 2)	Recommended Crimp Lug ⁽³⁾
30°C	140	(5) 750 kcmil	245348100
40°C	140	(5) 750 kcmil	
	168	(6) 750 kcmil	

- ¹ Cable sizes are based on recommendations of the American National Standards Institute (ANSI) approved National Fire Protection Association's (NFPA) National Electrical Code (NEC). Table 310.15 (B) (16) for copper wire at **90°C** conductor temperature. For operation in countries where the NEC is not recognized, follow applicable codes.
- ² Recommended cable sizes are sufficient to restrict voltage drop to 1.0 volt or less at rated full load output current of the bay for the loop lengths shown. Loop length is the sum of the lengths of the positive and negative leads.
- ³ Two-hole lug, 3/8" bolt clearance hole, 1" centers. Lugs should be crimped per lug manufacturer’s specifications.

Table 11
 Recommended Power/Distribution Bay Battery Cable Size and Lug Selection

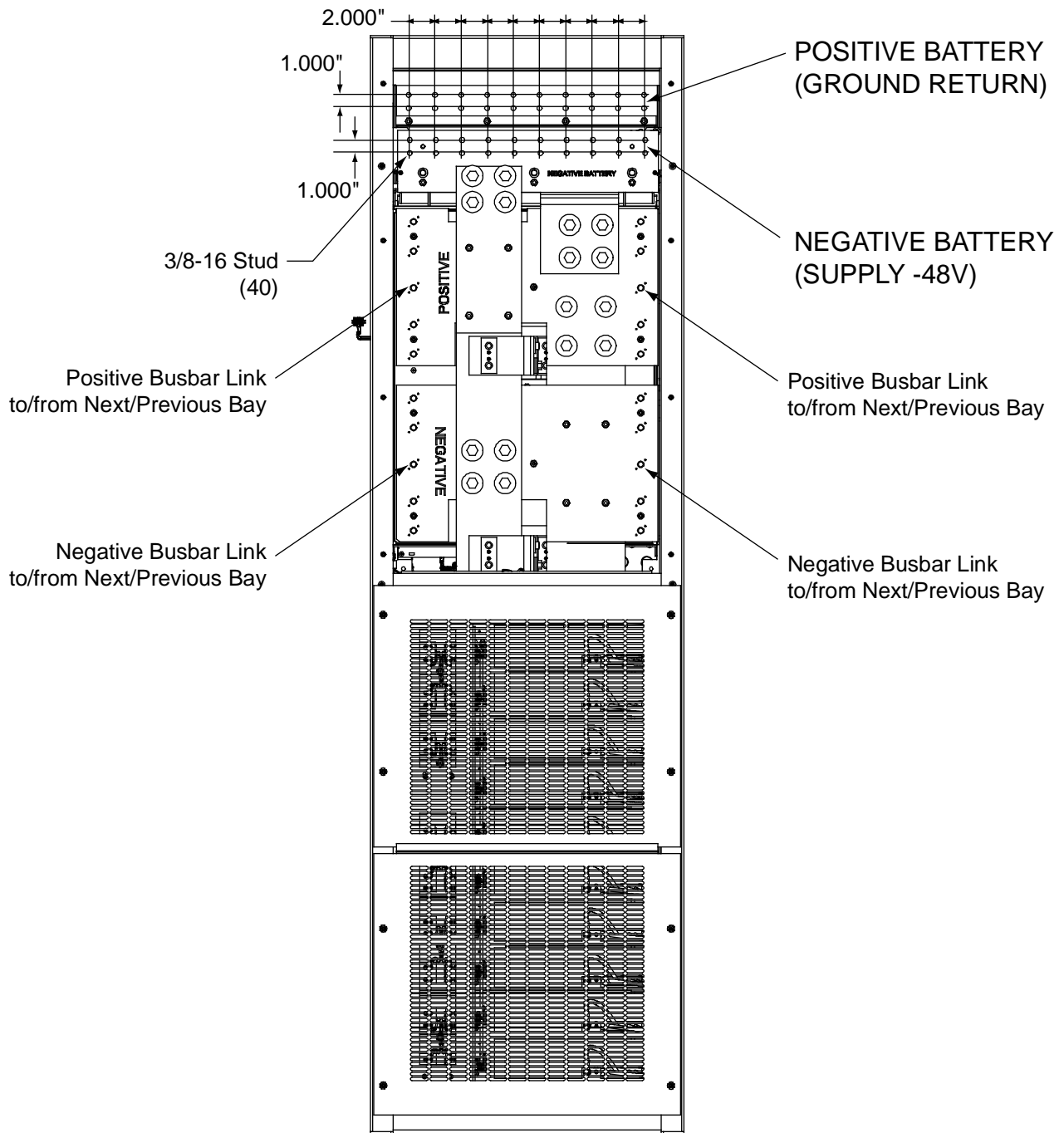

Rear View
 Power/Distribution Bays

Power Only Bay DC Output Cable Sizes and Lugs

Features

- ◆ Studs (3/8-16 on 1" centers) are provided for installation of customer provided two-hole lugs. These studs are accessed from the rear of the each power only bay. (Overhead busbars may be furnished. Refer to the section titled [Power/Distribution and Power Only Bays External Busbars](#) under "Accessory Descriptions" for battery lug selection.)
- ◆ For lug mounting hole size and spacing dimensions, refer to the illustration provided in this section.

Restrictions

All lugs for customer connections must be ordered separately.
Customer needs to supply lug mounting hardware.

Ordering Notes

- 1) DC output cable size varies depending on power requirements, therefore no specific information is provided for cable size. Refer to Table 12 for recommended cable sizes and lugs at rated maximum bay output (2200 amperes). When making connections, observe correct polarity.
- 2) Lugs should be crimped per lug manufacturer’s specifications.

Ambient Operating Temperature ⁽¹⁾	Loop Length ⁽²⁾ (Ft)	Recm 90°C Wire Size ^(1, 2)	Recommended Crimp Lug ⁽³⁾
30°C	140	(5) 750 kcmil	245348100
40°C	140	(5) 750 kcmil	
	168	(6) 750 kcmil	

- ¹ Cable sizes are based on recommendations of the American National Standards Institute (ANSI) approved National Fire Protection Association's (NFPA) National Electrical Code (NEC). Table 310.15 (B) (16) for copper wire at **90°C** conductor temperature. For operation in countries where the NEC is not recognized, follow applicable codes.
- ² Recommended cable sizes are sufficient to restrict voltage drop to 1.0 volt or less at rated full load output current of the bay for the loop lengths shown. Loop length is the sum of the lengths of the positive and negative leads.
- ³ Two-hole lug, 3/8" bolt clearance hole, 1" centers. Lugs should be crimped per lug manufacturer’s specifications.

Table 12
Recommended Power Only Bay DC Output Cable Size and Lug Selection

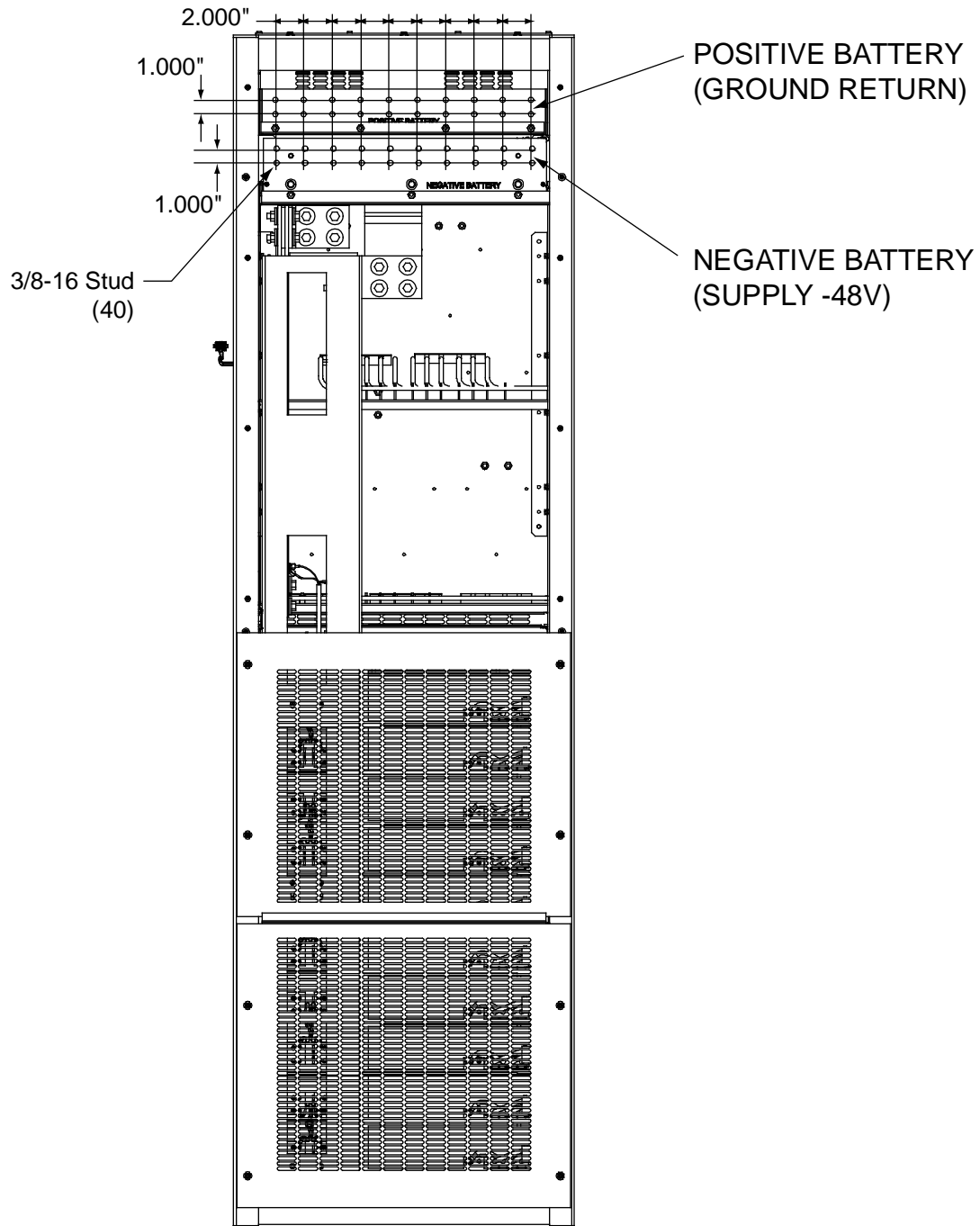

Rear View
Power Only Bays

Distribution Only Bay DC Input Cable Sizes and Lugs Selection

Features

- ◆ 3/8" clearance holes on 1" centers are provided for installation of customer provided DC input cables terminated in two-hole lugs. These are accessed from the rear of each Distribution Bay.
- ◆ For lug mounting hole size and spacing dimensions, refer to the illustration provided in this section.

Restrictions

All lugs for customer connections must be ordered separately.

Customer needs to supply lug mounting hardware.

Maximum size of wire to be connected to a single lug position is 750 kcmil (2 per lug position).

Maximum lug width, 2.000 inches.

Ordering Notes

- 1) DC input cable size varies depending on power requirements, therefore no specific information is provided for cable size. Refer to Table 13 for recommended cable sizes and lugs at rated maximum bay load (6000 amperes). When making connections, observe correct polarity.
- 2) Lugs should be crimped per lug manufacturer's specifications.

Ambient Operating Temperature ⁽¹⁾	Loop Length ⁽²⁾ (Ft)	Recm 90°C Wire Size ^(1, 2)	Recommended Crimp Lug ⁽³⁾
30°C	112	(10) 750 kcmil	245392000
40°C	112	(10) 750 kcmil	
	157	(14) 750 kcmil	

- ¹ Wire sizes are based on recommendations of the American National Standards Institute (ANSI) approved National Fire Protection Association's (NFPA) National Electrical Code (NEC). Table 310.15 (B) (16) for copper wire at 90°C conductor temperature. For operation in countries where the NEC is not recognized, follow applicable codes.
- ² Recommended wire sizes are sufficient to restrict voltage drop to 1.0 volt or less at rated full load output current of the bay for the loop lengths shown. Loop length is the sum of the lengths of the positive and negative leads.
- ³ Two-hole lug, 3/8" bolt clearance hole, 1" centers. Lugs should be crimped per lug manufacturer's specifications.

Table 13
 Recommended Distribution Bay DC Input Cable Size and Lug Selection

Power/Distribution Bay AC Input, Ten (10) AC Feeds Wire Sizes, Branch Circuit Protection, and Lugs

Features

- ◆ Studs (1/4-20 on 5/8" centers) are provided for installation of customer provided two-hole AC Input lugs.
- ◆ Studs (1/4-20) are provided for installation of customer provided one-hole frame ground lugs.
- ◆ For lug mounting hole size and spacing dimensions, refer to the illustration provided in this section.

Restrictions

All lugs for customer connections must be ordered separately.

List 101 and List 111 provide an AC input termination panel that accepts ten (10) AC input branch circuits, one (1) per rectifier mounting position.

Ordering Notes

- 1) Refer to Table 14 for recommended wire sizes, branch circuit protection, and lugs.

AC Feeds #1 through #10				
Ambient Operating Temperature ⁽¹⁾	Nominal Input Voltage (VAC)	Recm Branch Circuit Protection (Amperes) ⁽²⁾	Recm 90°C Wire Size (AWG) ^{(1) (4)}	Recommended Crimp Lug ⁽³⁾
30°C and 40°C	480	20	12	245342300
	208	50	6	245346700

- ¹ Wire sizes based on recommendations of the American National Standards Institute (ANSI) approved National Fire Protection Association's (NFPA) National Electrical Code (NEC). Table 310.15 (B) (16) for copper wire at **90°C** conductor temperature. For operation in countries where the NEC is not recognized, follow applicable codes.
- ² The AC input branch circuit protective device should be of the time-delay or high inrush type.
- ³ Two-hole lug, 1/4" bolt clearance hole, 5/8" centers. Lugs should be crimped per lug manufacturer's specifications.
- ⁴ Equipment grounding conductors must be provided with the AC input conductors supplied to the Bay. Frame ground terminals must be connected to earth ground, not power system neutral. Equipment grounding conductor size based on recommendations of the NEC Table 250-122 for copper wire. If aluminum or copper clad aluminum grounding conductor is used, refer to Table 250-122 for increased conductor size. For operation in countries where the NEC is not recognized, follow applicable codes.

Table 14
 Recommended AC Input Wire Size and Lug Selection
Ten (10) AC Feeds

Vertiv™ NetSure™ 8200 -48 VDC Power System

System Application Guide

480VAC (List A) or 208VAC (List B), 3 Phase, 60Hz

Separate Feed per PCU

PCU AC INPUT: 1/4-20 Studs on 5/8" Centers for Installation of Customer Provided Two-Hole Lugs

PCU #1	PCU #2	PCU #3	PCU #4	PCU #5	PCU #6	PCU #7	PCU #8	PCU #9	PCU #10																							
A	B	C	A	B	C	A	B	C	A	B	C	A	B	C	A	B	C	A	B	C	A	B	C	A	B	C	A	B	C	A	B	C

Frame Ground
(1/4-20 Studs
for Installation of
Customer Provided
One-Hole Lugs)

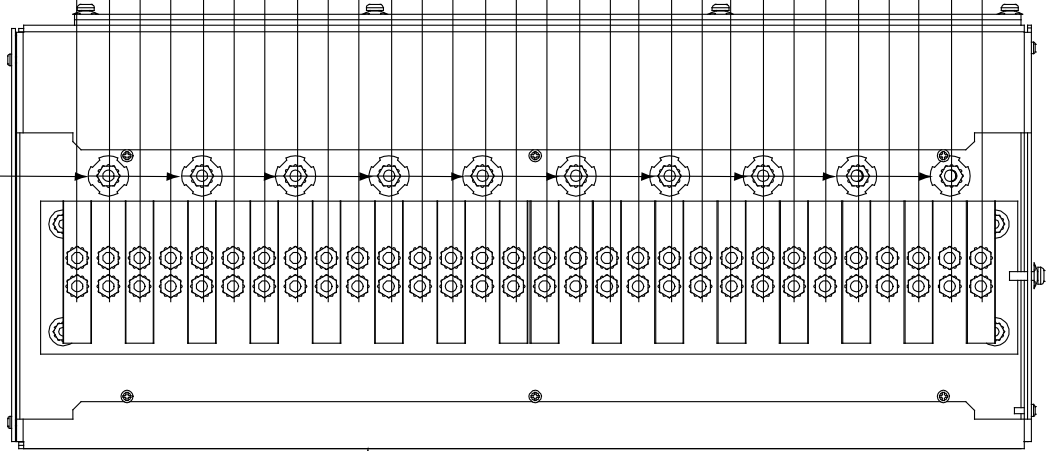

Cover Removed
in Illustration

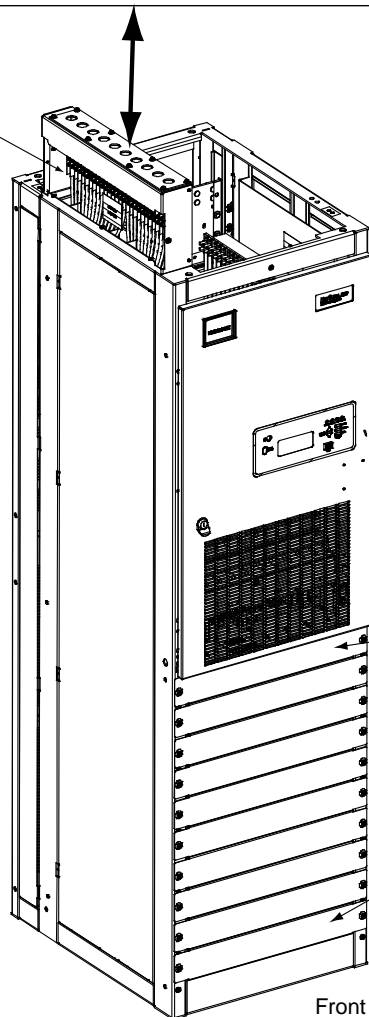

PCU #1
PCU #2
PCU #3
PCU #4
PCU #5
PCU #6
PCU #7
PCU #9
PCU #10

Front View

Vertiv™ NetSure™ 8200 -48 VDC Power System

System Application Guide

Power/Distribution Bay AC Input, Two (2) AC Feeds Wire Sizes, Branch Circuit Protection, and Lugs

Features

- ◆ Studs (3/8-16 on 1" centers) are provided for installation of customer provided two-hole AC Input lugs. These studs are accessed from the rear of the PDSC (AC Input 'Power Distribution Service Cabinet').
- ◆ Captive nuts (3/8-16 on 1" centers) are provided for installation of customer provided frame ground lugs. These studs are accessed from the rear of the PDSC (AC Input 'Power Distribution Service Cabinet').
- ◆ For lug mounting hole size and spacing dimensions, refer to the illustration provided in this section.

Restrictions

All lugs for customer connections must be ordered separately.

Requires optional bolt-on PDSC (AC Input 'Power Distribution Service Cabinet') (List 130 or 131).

For use with List 102 and List 112 only.

Ordering Notes

- 1) Refer to Table 15 for recommended wire sizes, branch circuit protection, and lugs.

AC Feeds #1 and #2				
Ambient Operating Temperature ⁽¹⁾	Nominal Input Voltage (VAC)	Recm Branch Circuit Protection (Amperes) ⁽²⁾	Recm 90°C Wire Size (AWG and kcmil) ⁽¹⁾ ⁽⁴⁾	Recommended Crimp Lug ⁽³⁾
30°C and 40°C	480	100	2	245348200
	208	250	250	245347500

- ¹ Wire sizes based on recommendations of the American National Standards Institute (ANSI) approved National Fire Protection Association's (NFPA) National Electrical Code (NEC). Table 310.15 (B) (16) for copper wire at **90°C** conductor temperature. For operation in countries where the NEC is not recognized, follow applicable codes.
- ² The AC input branch circuit protective device should be of the time-delay or high inrush type.
- ³ Two-hole lug, 3/8" bolt clearance hole, 1" centers. Lugs should be crimped per lug manufacturer's specifications.
- ⁴ Equipment grounding conductors must be provided with the AC input conductors supplied to the Bay. Frame ground terminals must be connected to earth ground, not power system neutral. Equipment grounding conductor size based on recommendations of the NEC Table 250-122 for copper wire. If aluminum or copper clad aluminum grounding conductor is used, refer to Table 250-122 for increased conductor size. For operation in countries where the NEC is not recognized, follow applicable codes.

Table 15
Recommended AC Input Wire Size and Lug Selection
Two (2) AC Feeds

Vertiv™ NetSure™ 8200 -48 VDC Power System
System Application Guide

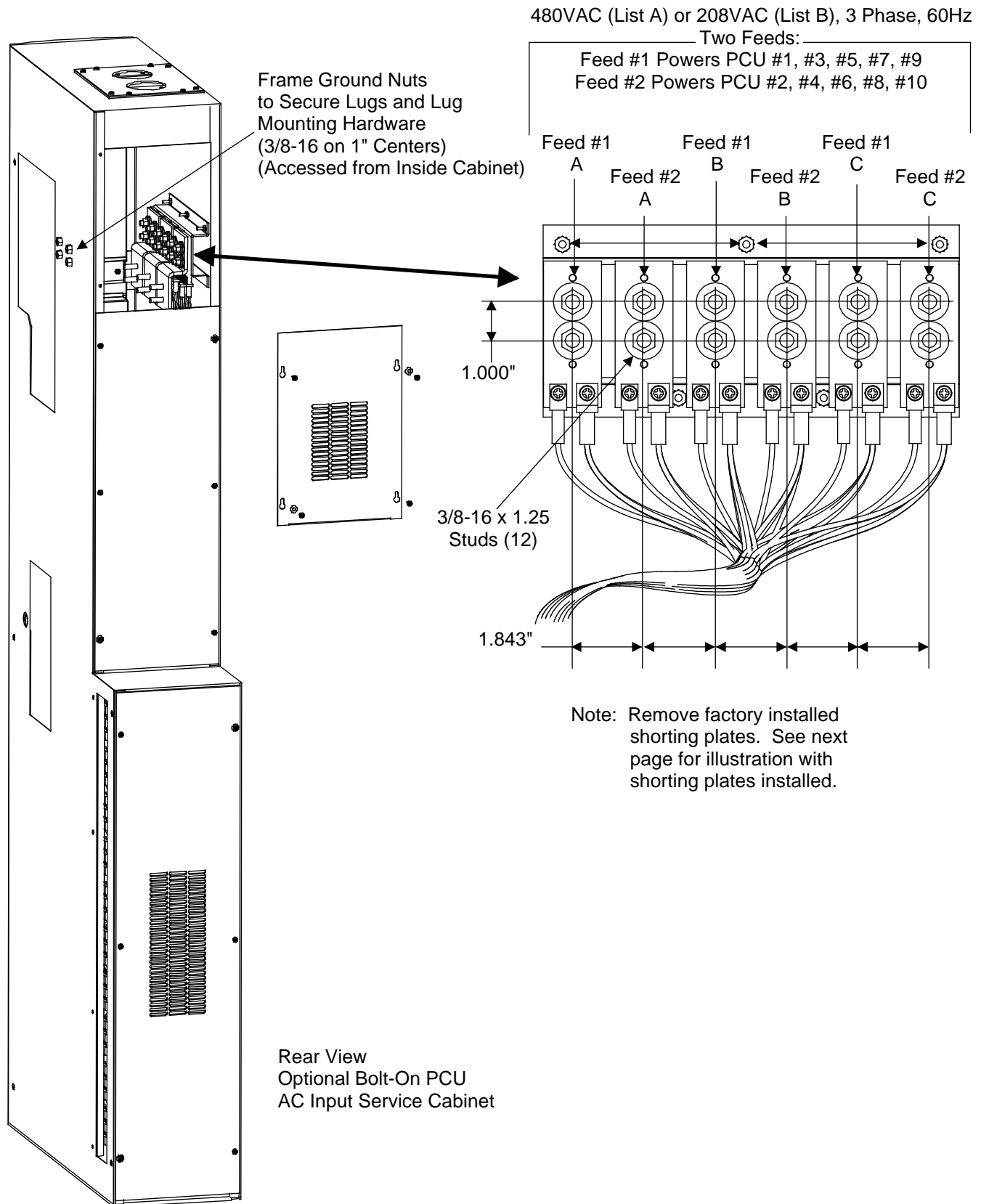

Vertiv™ NetSure™ 8200 -48 VDC Power System

System Application Guide

Power/Distribution Bay AC Input, One (1) AC Feed Wire Sizes, Branch Circuit Protection, and Lugs

Features

- ◆ Studs (3/8-16 on 1" centers) are provided for installation of customer provided two-hole AC Input lugs. These studs are accessed from the rear of the PDSC (AC Input 'Power Distribution Service Cabinet').
- ◆ Captive nuts (3/8-16 on 1" centers) are provided for installation of customer provided frame ground lugs. These studs are accessed from the rear of the PDSC (AC Input 'Power Distribution Service Cabinet').
- ◆ For lug mounting hole size and spacing dimensions, refer to the illustration provided in this section.

Restrictions

All lugs for customer connections must be ordered separately.

Requires optional bolt-on PDSC (AC Input 'Power Distribution Service Cabinet') (List 130 or 131).

For use with List 102 and List 112 only.

Ordering Notes

- 1) Refer to Table 16 for recommended wire sizes, branch circuit protection, and lugs.

AC Feed #1				
Ambient Operating Temperature ⁽¹⁾	Nominal Input Voltage (VAC)	Recm Branch Circuit Protection (Amperes) ⁽²⁾	Recm 90°C Wire Size (AWG and kcmil) ⁽¹⁾ _{⁽⁴⁾}	Recommended Crimp Lug ⁽³⁾
30°C and 40°C	480	200	3/0	245347300
	208	500	750	245348100

¹ Wire sizes based on recommendations of the American National Standards Institute (ANSI) approved National Fire Protection Association's (NFPA) National Electrical Code (NEC). Table 310.15 (B) (16) for copper wire at **90°C** conductor temperature. For operation in countries where the NEC is not recognized, follow applicable codes.

² The AC input branch circuit protective device should be of the time-delay or high inrush type.

³ Two-hole lug, 3/8" bolt clearance hole, 1" centers. Lugs should be crimped per lug manufacturer's specifications.

⁴ Equipment grounding conductors must be provided with the AC input conductors supplied to the Bay. Frame ground terminals must be connected to earth ground, not power system neutral. Equipment grounding conductor size based on recommendations of the NEC Table 250-122 for copper wire. If aluminum or copper clad aluminum grounding conductor is used, refer to Table 250-122 for increased conductor size. For operation in countries where the NEC is not recognized, follow applicable codes.

Table 16
Recommended AC Input Wire Size and Lug Selection
One (1) AC Feed

Vertiv™ NetSure™ 8200 -48 VDC Power System
 System Application Guide

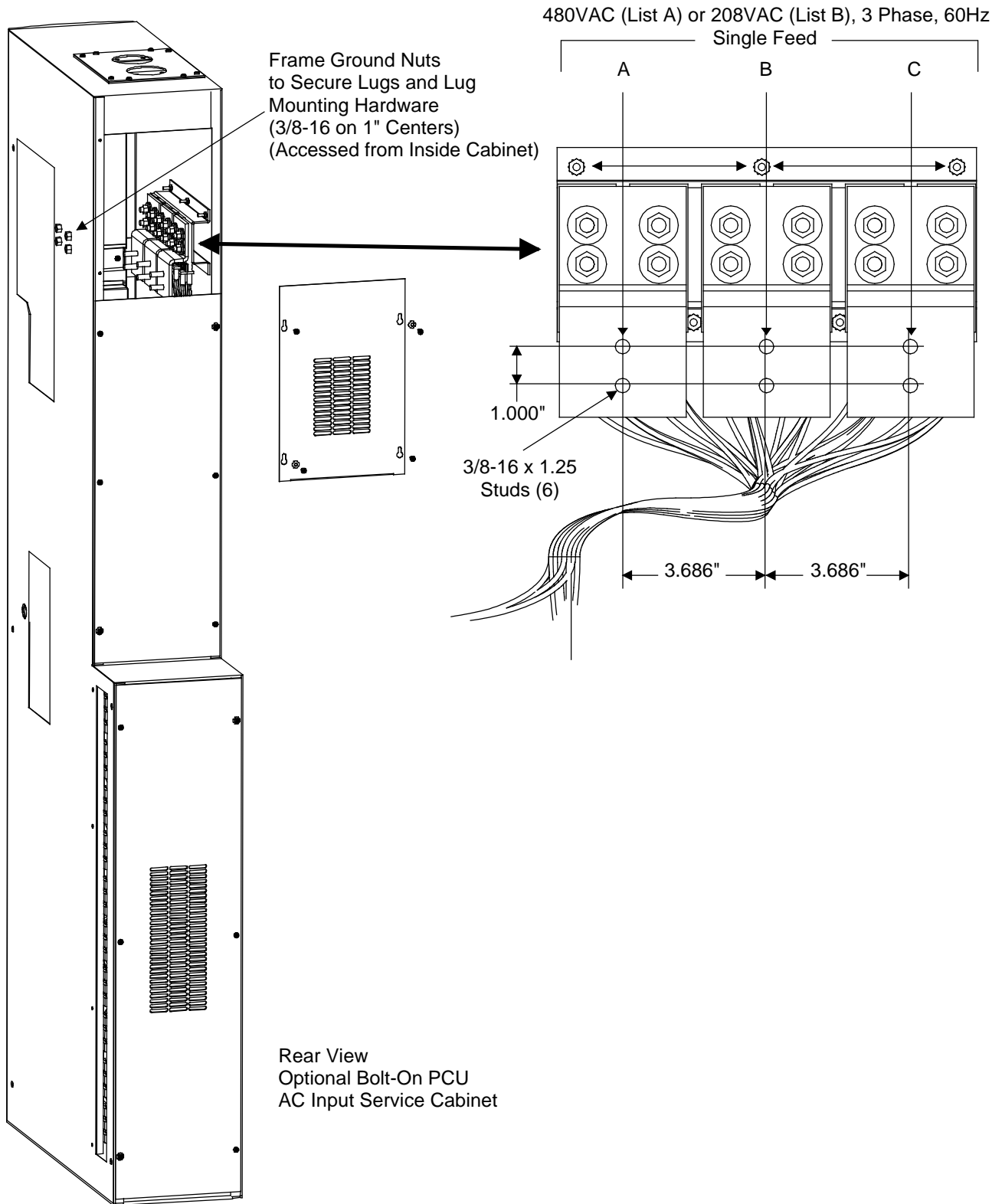

Power Only Bay AC Input, Five (5) AC Feeds Wire Sizes, Branch Circuit Protection, and Lugs

Features

- ◆ Studs (3/8-16 on 1" centers) are provided for installation of customer provided two-hole AC Input lugs and frame ground lugs.
- ◆ For lug mounting hole size and spacing dimensions, refer to the illustration provided in this section.

Restrictions

All lugs for customer connections must be ordered separately.
List 103 and List 113 provides five (5) AC feeds.

Ordering Notes

- 1) Refer to Table 18 for recommended wire sizes, branch circuit protection, and lugs.

AC Feeds #1 through #5				
Ambient Operating Temperature ⁽¹⁾	Nominal Input Voltage (VAC)	Recm Branch Circuit Protection (Amperes) ⁽²⁾	Recm 75°C Wire Size (AWG) ^{(1) (4)}	Recommended Crimp Lug ⁽³⁾
40°C	480	40 ⁽⁵⁾	8	245349800
	240	80 ⁽⁶⁾	2	245348200
	208	90 ⁽⁷⁾	2	245348200

- ¹ Wire sizes based on recommendations of the American National Standards Institute (ANSI) approved National Fire Protection Association's (NFPA) National Electrical Code (NEC). Table 310.15 (B) (16) for copper wire at **75°C** conductor temperature. For operation in countries where the NEC is not recognized, follow applicable codes.
- ² The AC input branch circuit protective device should be of the time-delay or high inrush type.
- ³ Two-hole lug, 3/8" bolt clearance hole, 1" centers. Lugs should be crimped per lug manufacturer's specifications.
- ⁴ Equipment grounding conductors must be provided with the AC input conductors supplied to the Bay. Frame ground terminals must be connected to earth ground, not power system neutral. Equipment grounding conductor size based on recommendations of the NEC Table 250-122 for copper wire. If aluminum or copper clad aluminum grounding conductor is used, refer to Table 250-122 for increased conductor size. For operation in countries where the NEC is not recognized, follow applicable codes.
- ⁵ Maximum overcurrent protection device is 45A.
- ⁶ Maximum overcurrent protection device is 90A.
- ⁷ Maximum overcurrent protection device is 100A.

Table 17
Recommended AC Input Wire Size and Lug Selection
Five (5) AC Feeds

Vertiv™ NetSure™ 8200 -48 VDC Power System
System Application Guide

480VAC (List A) or 208VAC (List B), 3 Phase, 60Hz

Five AC Feeds

- (Feed #1 Powers Rectifiers #1 and #2)
- (Feed #2 Powers Rectifiers #3 and #4)
- (Feed #3 Powers Rectifiers #5 and #6)
- (Feed #4 Powers Rectifiers #7 and #8)
- (Feed #5 Powers Rectifiers #9 and #10)

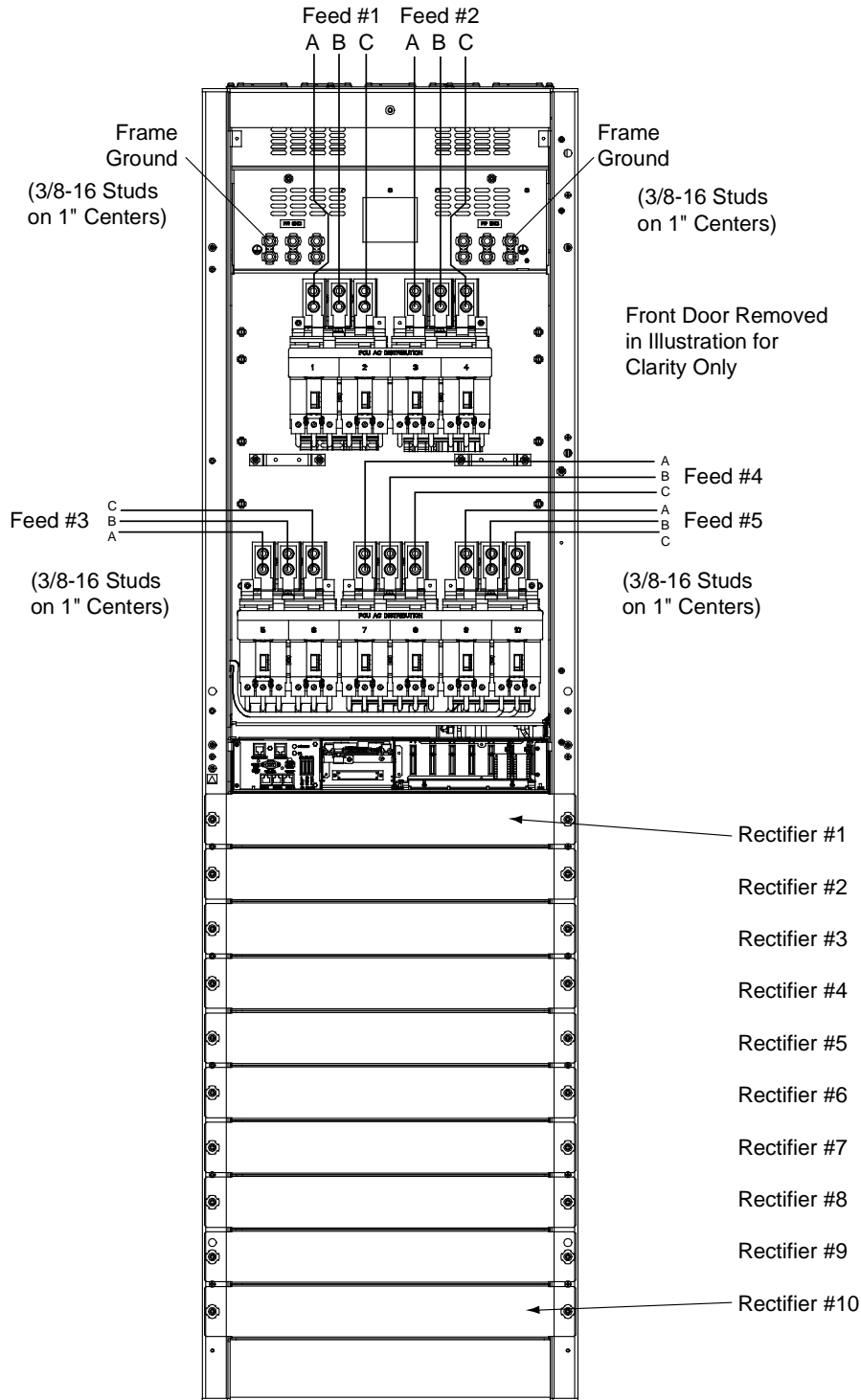

Front View

Power Only Bay AC Input, Two (2) AC Feeds Wire Sizes, Branch Circuit Protection, and Lugs

Features

- ◆ Studs (3/8-16 on 1" centers) are provided for installation of customer provided two-hole AC Input lugs and frame ground lugs.
- ◆ For lug mounting hole size and spacing dimensions, refer to the illustration provided in this section.

Restrictions

All lugs for customer connections must be ordered separately.
List 104 and List 114 provides two (2) AC feeds.

Ordering Notes

- 1) Refer to Table 18 for recommended wire sizes, branch circuit protection, and lugs.

AC Feeds #1 and #2				
Ambient Operating Temperature ⁽¹⁾	Nominal Input Voltage (VAC)	Recm Branch Circuit Protection (Amperes) ⁽²⁾	Recm 75°C Wire Size (AWG) ^{(1) (4)}	Recommended Crimp Lug ⁽³⁾
40°C	480	100 ⁽⁵⁾	2	245348200
	240	200	3/0	245347300
	208	225	4/0	245347400

- ¹ Wire sizes based on recommendations of the American National Standards Institute (ANSI) approved National Fire Protection Association's (NFPA) National Electrical Code (NEC). Table 310.15 (B) (16) for copper wire at **75°C** conductor temperature. For operation in countries where the NEC is not recognized, follow applicable codes.
- ² The AC input branch circuit protective device should be of the time-delay or high inrush type.
- ³ Two-hole lug, 3/8" bolt clearance hole, 1" centers. Lugs should be crimped per lug manufacturer's specifications.
- ⁴ Equipment grounding conductors must be provided with the AC input conductors supplied to the Bay. Frame ground terminals must be connected to earth ground, not power system neutral. Equipment grounding conductor size based on recommendations of the NEC Table 250-122 for copper wire. If aluminum or copper clad aluminum grounding conductor is used, refer to Table 250-122 for increased conductor size. For operation in countries where the NEC is not recognized, follow applicable codes.
- ⁵ Maximum overcurrent protection device is 110A.

Table 18
Recommended AC Input Wire Size and Lug Selection
Two (2) AC Feeds

Vertiv™ NetSure™ 8200 -48 VDC Power System
 System Application Guide

480VAC (List A) or 208VAC (List B), 3 Phase, 60Hz
 Two AC Feeds

(Feed #1 Powers Rectifiers #1, #3, #5, #7, #9)
 (Feed #2 Powers Rectifiers #2, #4, #6, #8, #10)

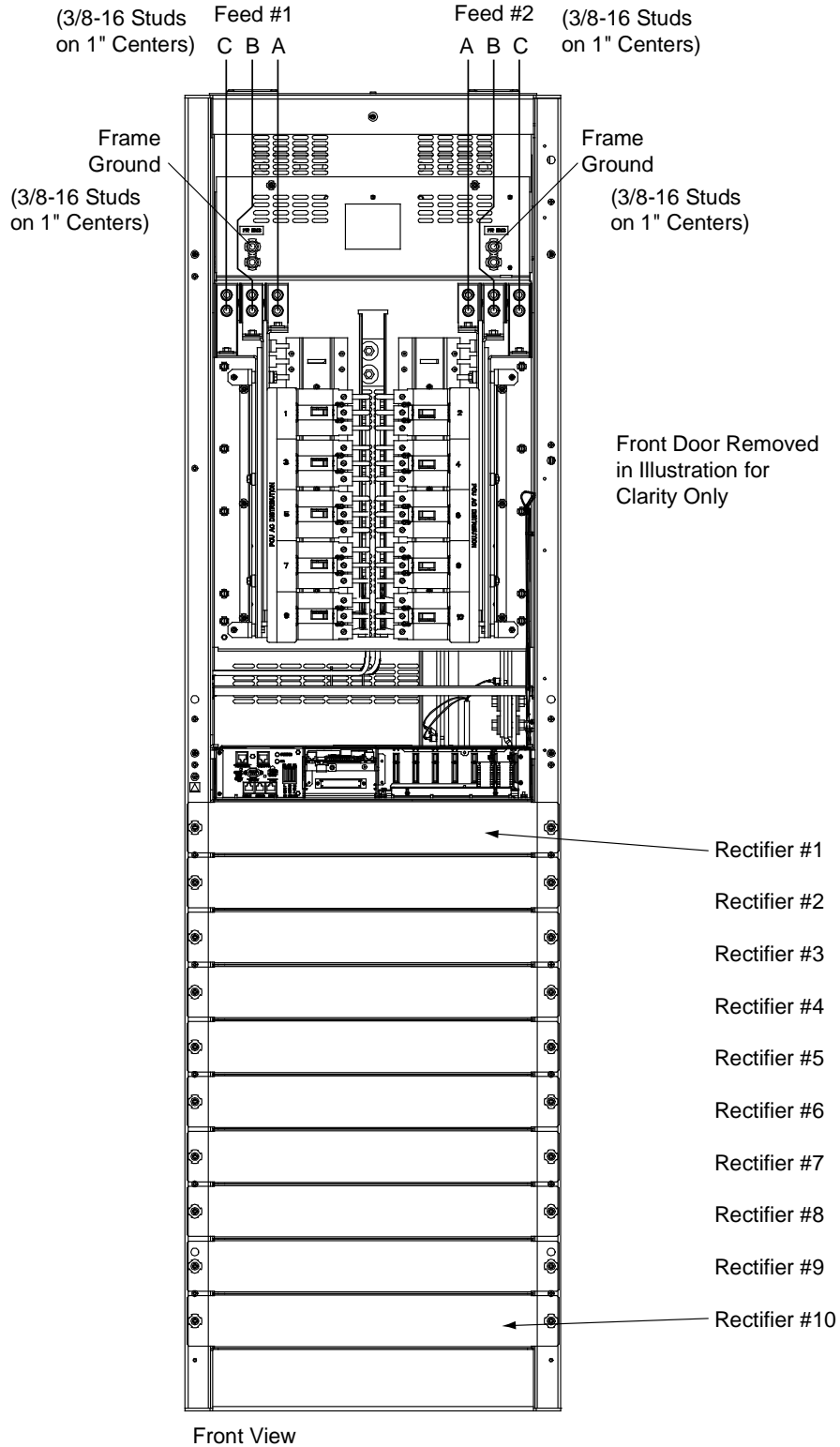

Power Only Bay AC Input, Ten (10) AC Feeds Wire Sizes, Branch Circuit Protection, and Lugs

Features

- ◆ Studs (1/4-20 on 5/8" centers) are provided for installation of customer provided two-hole AC Input lugs.
- ◆ Studs (1/4-20) are provided for installation of customer provided one-hole frame ground lugs.
- ◆ For lug mounting hole size and spacing dimensions, refer to the illustration provided in this section.

Restrictions

All lugs for customer connections must be ordered separately.
List 105 and List 115 provides ten (10) AC feeds.

Ordering Notes

- 1) Refer to Table 19 for recommended wire sizes, branch circuit protection, and lugs.

AC Feeds #1 through #10				
Ambient Operating Temperature ⁽¹⁾	Nominal Input Voltage (VAC)	Recm Branch Circuit Protection (Amperes) ⁽²⁾	Recm 75°C Wire Size (AWG) ^{(1) (4)}	Recommended Crimp Lug ⁽³⁾
40°C	480	20 ⁽⁵⁾	12	245342300
	240	40	8	245391600
	208	45 ⁽⁶⁾	6	245346700

- ¹ Wire sizes based on recommendations of the American National Standards Institute (ANSI) approved National Fire Protection Association's (NFPA) National Electrical Code (NEC). Table 310.15 (B) (16) for copper wire at 75°C conductor temperature. For operation in countries where the NEC is not recognized, follow applicable codes.
- ² The AC input branch circuit protective device should be of the time-delay or high inrush type.
- ³ Two-hole lug, 1/4" bolt clearance hole, 5/8" centers. Lugs should be crimped per lug manufacturer's specifications.
- ⁴ Equipment grounding conductors must be provided with the AC input conductors supplied to the Bay. Frame ground terminals must be connected to earth ground, not power system neutral. Equipment grounding conductor size based on recommendations of the NEC Table 250-122 for copper wire. If aluminum or copper clad aluminum grounding conductor is used, refer to Table 250-122 for increased conductor size. For operation in countries where the NEC is not recognized, follow applicable codes.
- ⁵ Maximum overcurrent protection device is 25A.
- ⁶ Maximum overcurrent protection device is 60A.

Table 19
Recommended AC Input Wire Size and Lug Selection
Ten (10) AC Feeds

Vertiv™ NetSure™ 8200 -48 VDC Power System
System Application Guide

480VAC (List A) or 208VAC (List B), 3 Phase, 60Hz
Ten AC Feeds

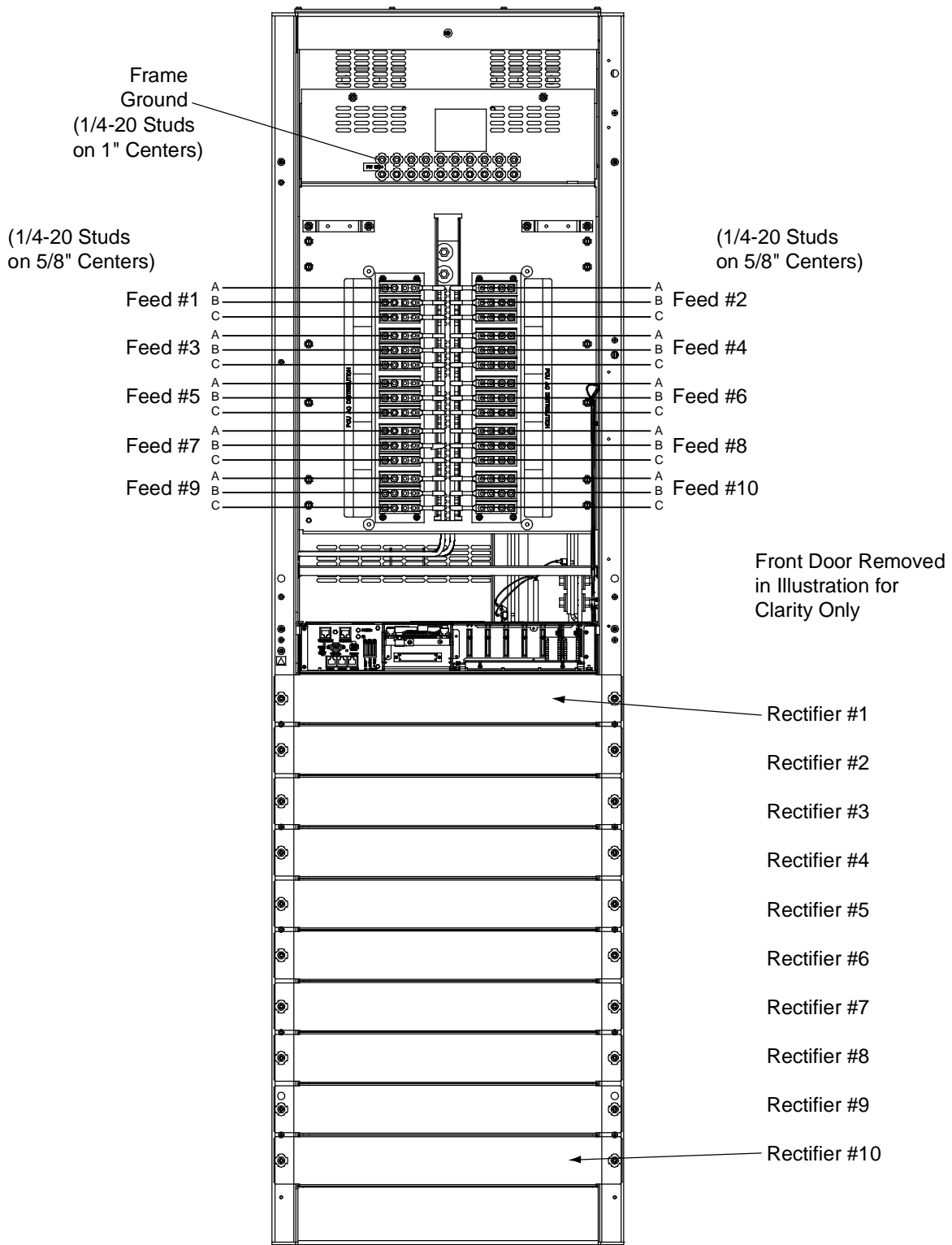

Front View

External Alarm, Reference, and Control Wire Sizes - Power/Distribution and Power Only Bays (List 101, 102, 103, 104, 105)

Recommended External Alarm, Reference, Monitoring, and Control Wire Sizes

Recommended wire size is 22 AWG for loop lengths up to 200 ft. and 18-20 AWG for loop lengths over 200 ft.

External Alarm, Reference, Monitoring, and Control Connections Primary Bay Overview Illustration

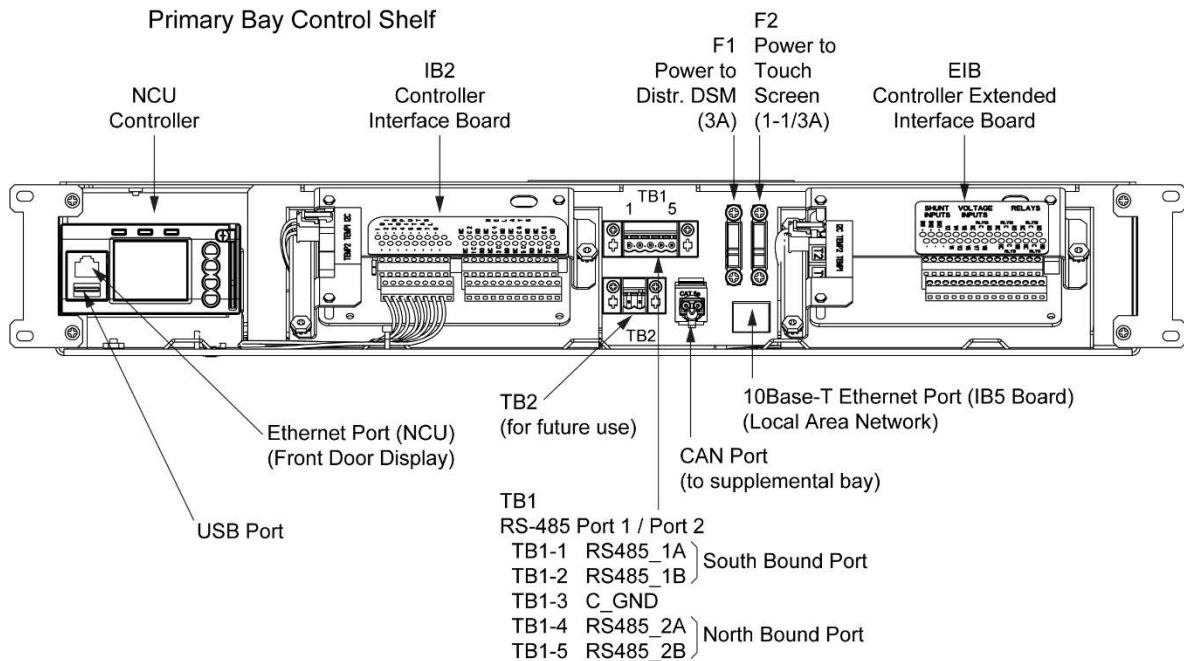
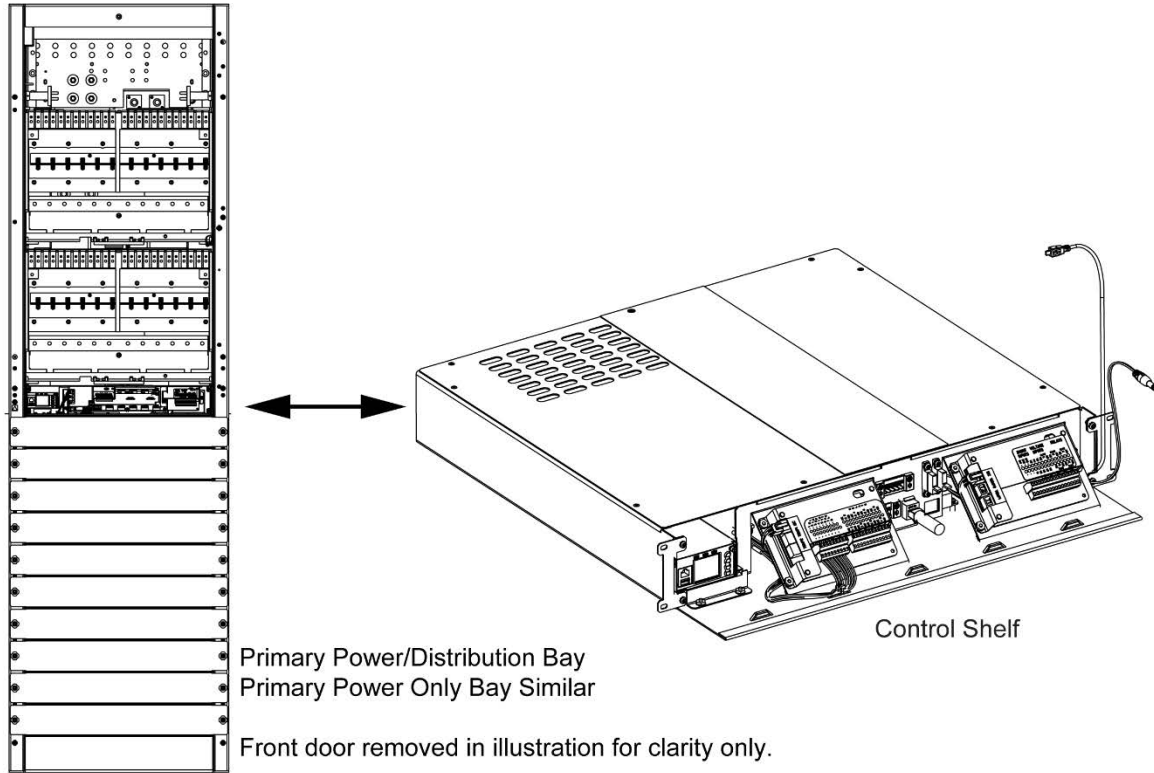

NCU Interface Board (IB2) Illustration

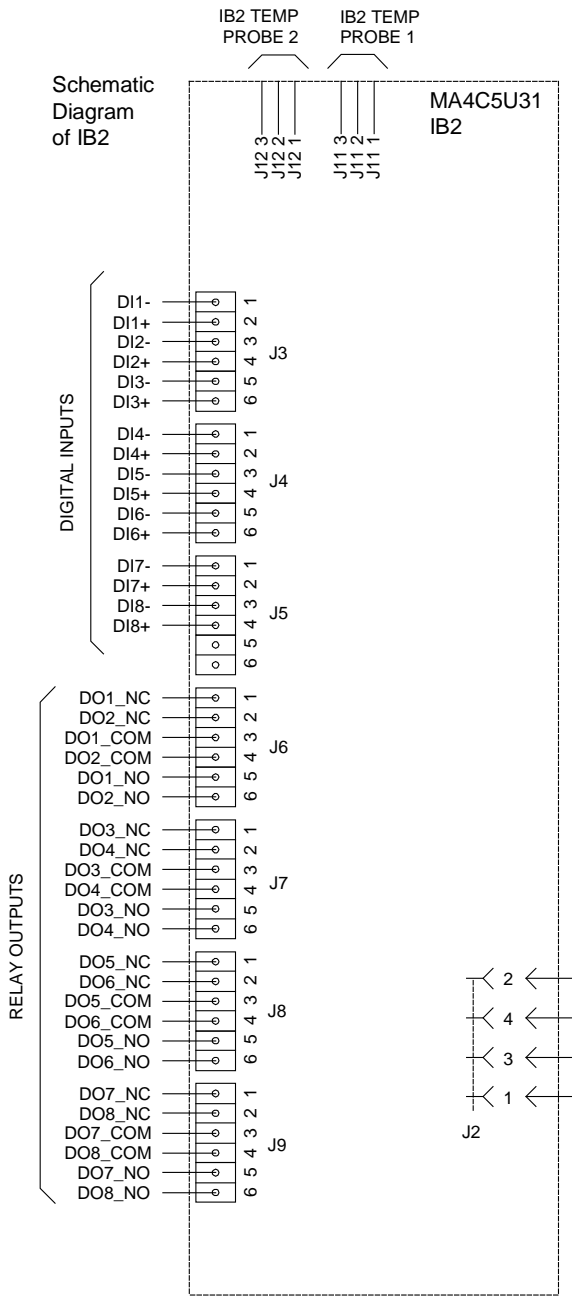

IB2 Assembly

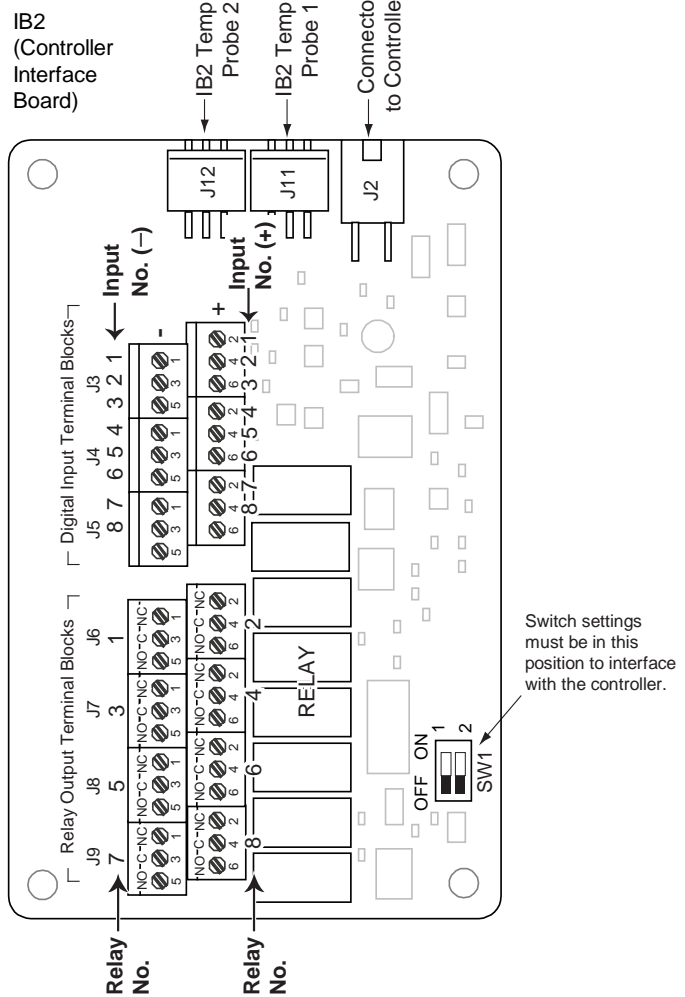
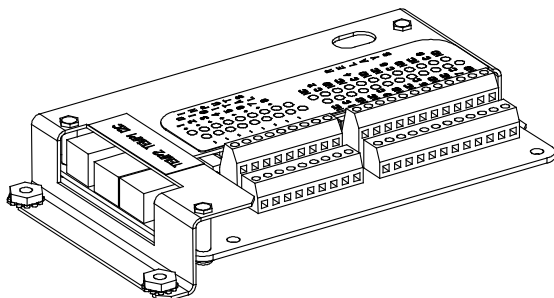

The controller relay assigned to “Critical Summary” alarm (relay 1 by default) will operate in the “Fail Safe Mode”. “Fail Safe Mode” means Relay 1 is de-energized during an alarm condition, opening the contacts between the C and NO terminals, and closing the contacts between the C and NC terminals.

The controller’s remaining seven (7) relays energize during an alarm condition, closing the contacts between the C and NO terminals, and opening the contacts between the C and NC terminals.

Not all I/O points may be available for customer connection (some may be used for factory system connections). Refer to the configuration drawing (C-drawing) supplied with your system for your system’s specific configuration.

J3-J9:

- Wire Size Capacity: 16 AWG to 26 AWG.
- Wire Strip Length: 0.20 inch.
- Recommended Torque: 2.2 in-lbs.

NCU Extended Interface Board (EIB) Illustration

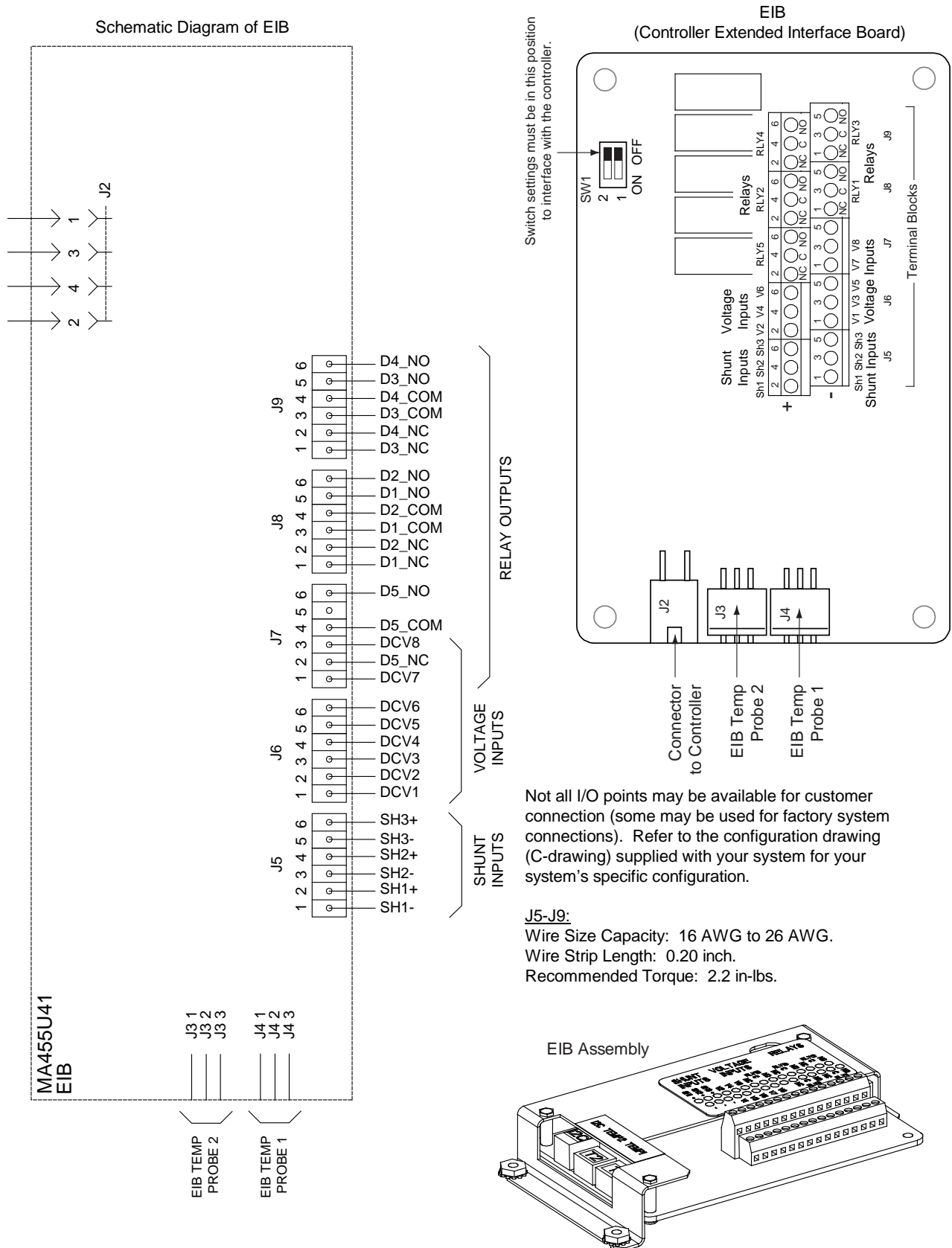

External Alarm, Reference, Monitoring, and Control Connections Secondary Bay Overview Illustration

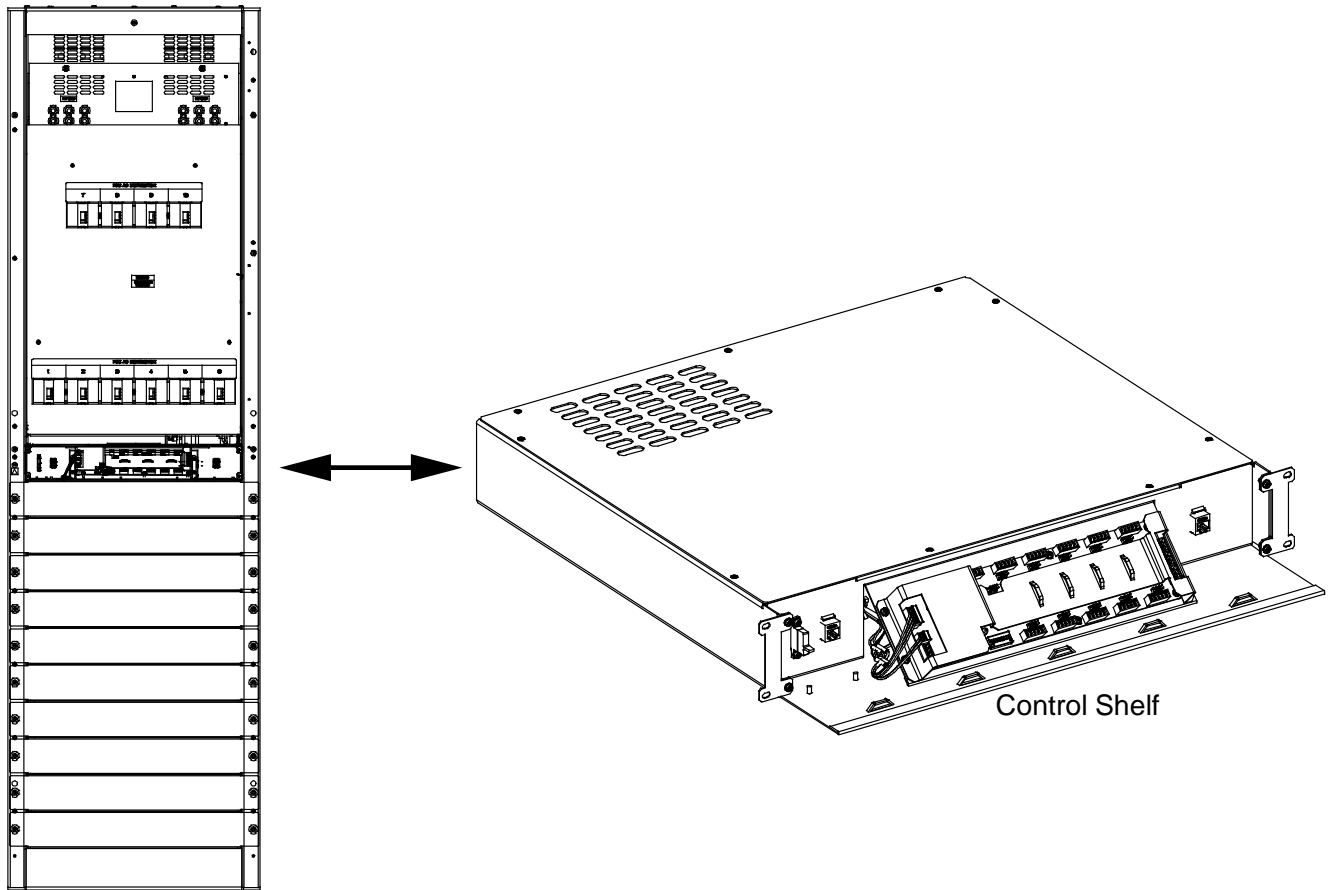

Secondary Power Only Bay
Secondary Power/ Distribution Bay Similar

Front door removed in illustration for clarity only.

Secondary Bay Control Shelf

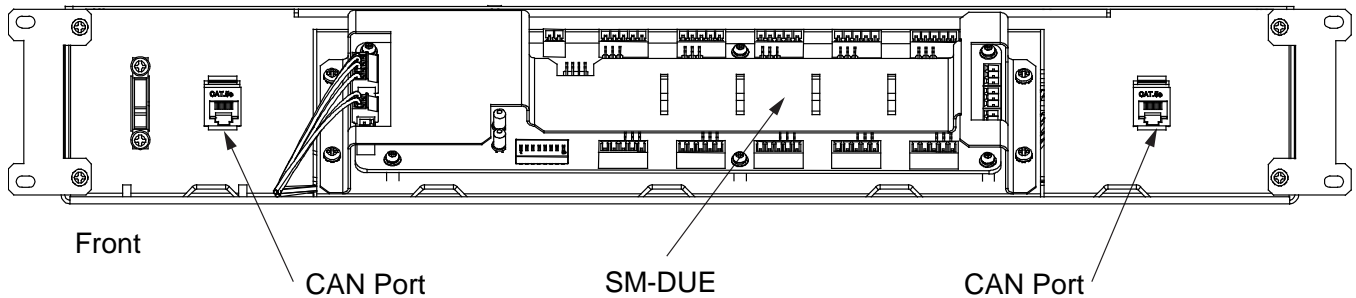

SPECIFICATIONS

1. SYSTEM

1.1 DC Operating Voltage

1.1.1 Nominal: -48 VDC.

1.1.2 Range: -42 VDC to -60 VDC.

1.2 Environmental Ratings

Note: See also 'Environmental Ratings' in the Rectifier Module section.

1.2.1 Operating Ambient Temperature Range: 0 °C to +40 °C (+32 °F to +104 °F).

1.2.2 Storage Ambient Temperature Range: -40 °C to +65 °C (-40 °F to +149 °F).

1.2.3 Humidity: This system is capable of operating in an ambient relative humidity range of 0% to 95%, noncondensing.

1.2.4 Altitude: The maximum operating ambient temperature should be derated by 10 °C at an elevation of 10,000 feet above sea level. For elevations between 3,000 feet and 10,000 feet, derate the maximum operating ambient temperature linearly.

1.2.5 Heat Dissipation: With R48-12000e rectifier(s) output adjusted to 54.48 volt DC at rated full load and nominal input voltage.

R48-12000e Rectifier (P/N 486532603)		
No. of Rectifiers	Bay Output Current (Amperes)	BTU/Hr (Typical)
1	0 (Rectifier no load)	390
1	100 (Rectifier half load)	800
1	200 (Rectifier full load)	1568
2	400	3136
3	600	4704
4	800	6272
5	1000	7840
6	1200	9408
7	1400	10976
8	1600	12544
9	1800	14112
10	2000	15680

Vertiv™ NetSure™ 8200 -48 VDC Power System

System Application Guide

1.2.6 Heat Dissipation: With R48-12000Le rectifier(s) output adjusted to 54.48 volt DC at rated full load and nominal input voltage.

R48-12000Le Rectifier P/N 486534003		
No. of Rectifiers	Bay Output Current (Amperes)	BTU/Hr (Typical)
1	0 (Rectifier no load)	--
1	100 (Rectifier half load)	--
1	200 (Rectifier full load)	2404
2	400	4808
3	600	7212
4	800	9616
5	1000	12020
6	1200	14424
7	1400	16828
8	1600	19232
9	1800	21636
10	2000	24040

1.2.7 Ventilation Requirements: The rectifiers are fan cooled and utilize front to back forced ventilation. The power/distribution bays and power only bays must be mounted so ventilating openings are not blocked and temperature of the air entering the rectifier shelf does not exceed the operating ambient temperature range stated above.

Also, the distance from the rear of a power/distribution bay or power only bay to a wall or other solid structure must not be less than 6 inches. This will assure proper air flow through the rectifiers.

1.2.8 Audible Noise: The audible noise does not exceed the following when measured at any point two feet from any vertical surface of a power/distribution bay and five feet from the floor using a sound level meter conforming to ANSI S1.4.

No. of Rectifiers	Audible Noise
1	65 dBA
10	75 dBA

1.2.9 EMI/RFI Suppression: Rectifiers operating in a Power/Distribution Bay conform to the requirements of FCC rules Part 15, Subpart B, Class A for Radiated and Conducted emissions limits.

1.2.10 Surge Protection

(A) Standard: Compliance with EN61000-4-5 Installation Class 4, and capable of withstanding surges per ANSI/IEEE C 62.41-1991 Category B across the input terminals.

Note: This level of protection is a widely used standard for telecommunications power equipment. As with all such equipment, it is the end user's responsibility to provide an adequately sized Surge Suppression Device at the commercial power service entrance of the building that reduces all incoming surges to levels below the classes/categories stated for the equipment.

(B) When Equipped with List 35, 36, 37, or 38: Compliance with EN61000-4-5 Installation Class 4, and capable of withstanding surges per ANSI/IEEE C62.41-1991 Category A, Category B, and Category C, and ANSI/IEEE C62.41.2 Scenario II, Exposure 3, 100KA 8/20us, 10KA 10/350us.

1.2.11 ESD Protection: Complies with EN61000-4-2 Level 4 (8kV contact).

1.2.12 Electrical Fast Transient / Burst Immunity: Complies with EN61000-4-4 Level 4.

1.2.13 Mounting: This power system is intended only for installation in a restricted access location on or above a non-combustible surface. Typical industry standards recommend minimum aisle space clearance of 2'6" for the front of the relay rack and 2' for the rear of the relay rack.

Vertiv™ NetSure™ 8200 -48 VDC Power System

System Application Guide

1.3 Compliance Information

1.3.1 Safety Compliance:

- (A) Power/Distribution Bay and Distribution Only Bay: This power board is UL Listed ("c UL") as a DC Power Distribution Center for Communications Equipment. This unit meets the requirements of CSA 22.2, No. 225 and is tested and Certified by UL ("c UL") as a Custom Built Power Distribution Center for Communications Equipment.
- (B) Power Only Bay: This unit meets the requirements of UL 60950, Standard for Information Technology Equipment, and is UL Listed as a power supply for use in Telephone, Electronic Data Processing or Information Processing Equipment.

1.3.2 NEBS Compliance (pending for Lists 101-132): Compliance verified by a Nationally Recognized Testing Laboratory (NRTL) per GR-1089-CORE and GR-63-CORE. Contact Vertiv for NEBS compliance reports.

In order to remain compliant during a fan failure condition, the backup battery connection must be utilized to provide sufficient power to the loads for up to eight (8) hours when the system is operated at greater than 50% output power. If no backup battery connection is used, the system must operate with a redundant module installed.

1.4 Local Controls and Indicators

1.4.1 "Bay Alarm" Indicator: Located at the top center of each bay.

- Green = OK
- Red = Bay Failure
- Yellow (flashing) = Identified by the controller

1.4.2 "Distribution Bus" Indicators: Each distribution bus contains an indicator located on a hinged door panel covering the bus's controller monitoring circuit card.

- Green = OK
- Red = Card Failure
- Yellow (flashing) = Identified by the controller

1.4.3 See also specifications for rectifier, MCA, LMS, and NCU.

2. DC DISTRIBUTION

2.1 Ratings

2.1.1 Power/Distribution Bay

- (A) Power/Distribution Bay: 2400 amperes, maximum, per bay.
16,000 amperes, maximum, per system.
- (B) Distribution Bus: 1200 amperes, maximum.
Each Power/Distribution Bay has two (2) Distribution Buses.
- (C) Fuse/Circuit Breaker Mounting Positions: Each distribution bus contains 24 fuse/circuit breaker mounting positions which provides 48 fuse/circuit breaker mounting positions per bay. Note that some fuse/circuit breaker combinations require more than one fuse/circuit breaker mounting position. Refer to [Distribution Devices](#) under *ACCESSORY DESCRIPTIONS* for details.

2.1.2 Distribution Only Bay

- (A) Distribution Only Bay: 6000 amperes, maximum, per bay.
16,000 amperes, maximum, per system.
- (B) Distribution Bus: 1500 amperes, maximum.
Each bay has four (4) Distribution Buses.
- (C) Optional Distribution Panel: 500 amperes, maximum.
One optional Distribution Panel per Distribution Bay.
- (D) Fuse/Circuit Breaker Mounting Positions: Each distribution bus contains 12 fuse/circuit breaker mounting positions which provide 48 fuse/circuit breaker mounting positions per bay. Note that some fuse/circuit breaker combinations require more than one fuse/circuit breaker mounting position. Refer to [Distribution Devices](#) under *ACCESSORY DESCRIPTIONS* for details.

The optional distribution panel provides twenty-four (24) bullet nose device positions. The panel accepts a choice of TLS/TPS-type fuseholders or bullet nose-type circuit breakers. When installed, bay can be loaded with up to (46) 218 circuit breakers or TPL fuses, and (24) bullet nose circuit breakers or TLS/TPS fuses.

Note: The List C Circuit Breaker/Fuse Panel requires distribution position #12 in the Bus #1 Distribution Panel. Also, distribution position #36 in the Bus #3 Distribution Panel must remain empty.

3. RECTIFIER

3.1 Output Ratings

3.1.1 Voltage: Nominal -48 volts DC, Positive Ground.

- (A) Without Battery Charge Temperature Compensation: Float voltage is adjustable from 47.00 to 58.00 volts DC. Test/equalize voltage is adjustable from 45.00 to 58.00 volts DC. Both float and test/equalize voltages are factory set at 52.00 volts, unless otherwise specified. The output voltage temperature coefficient does not exceed 0.01% per degree centigrade from 0 °C to +40 °C.
- (B) With Battery Charge Digital Temperature Compensation Probe: With an optional battery charge digital temperature compensation probe installed, the controller automatically increases or decreases the output voltage as battery ambient temperature decreases or increases, respectively. Float voltage is factory set at approximately 54.48 volts at 25°C battery ambient. The float and test/equalize voltage range is the same as without battery charge temperature compensation. Using battery and equipment manufacturers' recommendations, the user selects the following temperature compensation curve parameters via the controller. Refer to "Typical Float Charge Thermal Characteristics Using Optional Battery Charge Digital Temperature Compensation Probe" in *Battery Charge Temperature Compensation Probe for Digital Compensation* under *ACCESSORY DESCRIPTIONS*.
 - (1) The temperature compensation slope in volts/°C. Adjustable from zero to 200 millivolts/°C. Factory set at 0V/°C (DIGITAL TC OFF).
 - (2) The maximum voltage limit in volts DC. Adjustable from float up to 58.5 volts DC, but automatically limited to one volt below the High Voltage Shutdown setting. Factory set at 56.5 volts DC.
 - (3) The minimum voltage limit in volts DC. Adjustable from float down to 44 volts DC. Factory set at 50.0 volts DC.

3.1.2 Current: Two hundred (200) amperes per rectifier, up to a total of 2,000 amperes per Power/Distribution Bay with ten (10) rectifiers installed, and up to a total of 16,000 amperes per system when equipped with 80 rectifiers.

3.1.3 Regulation

- (A) Static: The controller controls the steady state output voltage to within $\pm 0.05\%$ of any voltage setting within the range of 44.0 to 58.0 volts DC for any and all combinations of load from no load to full load, input voltage, and input frequency at a constant ambient temperature. If the controller's regulation feature is disabled for any reason, steady state regulation is $\pm 1.0\%$ as controlled within the rectifiers.
- (B) Dynamic Response: For any step load change from 10% to 90% or from 90% to 10% of full rated load within 250 microseconds, shall not cause the voltage measured at the output to overshoot or undershoot more than 5% of the regulated output level within 1 millisecond. The output voltage must return and stay within the $\pm 1\%$ regulation band within 4 milliseconds and within the $\pm 0.5\%$ regulation band within 3 seconds. Any step change of the line voltage within the limits specified in Paragraph 3.2.1 shall not cause the output voltage to deviate outside the $\pm 0.5\%$ regulation band.

3.1.4 Filtering (with or without battery): Typical readings were taken at nominal input voltage, nominal output voltage, 50% load, and 25°C (77°F) ambient.

- (A) Voice Band Noise: Complies with Telcordia GR-947-CORE.
 - (1) Typically 21 dB_{rn} with C-message weighting. Does not exceed 38 dB_{rn} C.
 - (2) Typically 0.100 millivolt psophometric. Does not exceed 2 millivolt psophometric.
- (B) Wide Band Noise: Complies with Telcordia GR-947-CORE.
 - (1) Typically 200 millivolt peak-to-peak. Does not exceed 250 millivolt peak-to-peak.
 - (2) Typically 10 millivolts rms. Does not exceed 100 millivolt rms.

3.2 Input Ratings (480VAC, with 486532603 rectifier)

- 3.2.1 Voltage: Nominal 480 volts AC, three phase, 60 Hz, with an operating range of 340 to 528 volts. Acceptable input frequency range is 57 to 63 Hz.
- 3.2.2 Harmonic Content: Complies with IEEE-519-1992. Voltage harmonic distortion of less than 5% at nominal input when operating on a line impedance of 0.104 ohms or less.
- 3.2.3 Inrush Current: Peak does not exceed 6 times the RMS input current at full load, under any conditions of input voltage within the rated input voltage range stated in Paragraph 3.3.1 and for any duration of AC input interrupts. Under the above conditions, standard AC distribution circuit breakers will not trip.

Vertiv™ NetSure™ 8200 -48 VDC Power System System Application Guide

3.2.4 Typical Input Data: 60 Hz input.

(A) System output is initially adjusted to 54.48 volts DC as measured at the output bus at 50% of full load and nominal input.

Number of Rectifiers Installed	Nominal Input Voltage	Percent of Full Load	Input Current (Amperes)	Input VA	Input Watts	Power Factor	Efficiency %
1	480	0	1.35	1122	0	0.074	--
		25	3.78	3147	2713	0.908	94.0
		50	6.99	5813	5429	0.973	95.9
		75	10.30	8563	8120	0.987	96.1
		100	13.66	11358	10797	0.992	95.9

(B) Typical Efficiency versus Output Current:

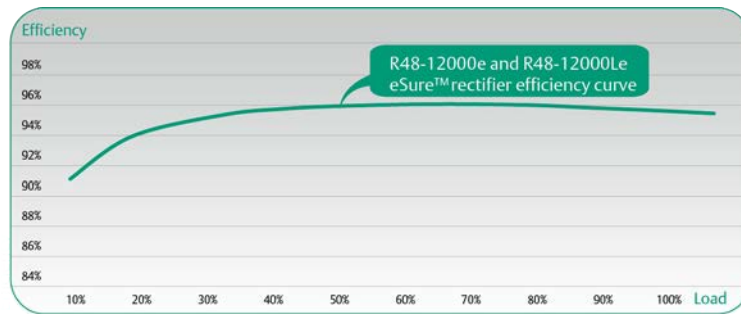

(C) Maximum input current at 100% of full load with output adjusted to 58 volts DC as measured at the output bus.

Nominal Input Voltage	Input Voltage	Number of Rectifiers Installed	Input Current (Amperes)
480	408	1	17.5
		2	35.0
		3	52.5
		4	70.0
		5	87.5
		6	105.0
		7	122.5
		8	140.0
		9	157.5
		10	175.0

3.3 Input Ratings (208VAC, with 486534003 rectifier)

3.3.1 Voltage: Nominal 208 volts AC, three phase, 60 Hz, with an operating range of 176 to 264 volts. Acceptable input frequency range is 47 to 63 Hz.

3.3.2 Harmonic Content: Complies with IEEE-519-1992. Voltage harmonic distortion of less than 5% when operating on a line impedance of 0.104 ohms or less.

3.3.3 Inrush Current: Peak does not exceed 6 times the RMS input current at full load, under any conditions of input voltage within the rated input voltage range stated in Paragraph 3.2.1 and for any duration of AC input interrupts. Under the above conditions, standard AC distribution circuit breakers will not trip.

Vertiv™ NetSure™ 8200 -48 VDC Power System System Application Guide

3.3.4 Typical Input Data: 60 Hz input.

(A) System output is initially adjusted to 54.48 volts DC as measured at the output bus at 50% of full load and nominal input.

Number of Rectifiers Installed	Nominal Input Voltage	Percent of Full Load	Input Current (Amperes)	Input VA	Input Watts	Power Factor	Efficiency %
1	208	0	0.692	40.8	6.69	0.164	--
		25	8.196	2883	.2811	0.975	94.7
		50	15.897	5688	.5648	0.993	95.7
		75	23.900	8571	8537	0.996	95.3
		100	32.140	11519	11496	0.998	94.5

(B) Typical Efficiency versus Output Current:

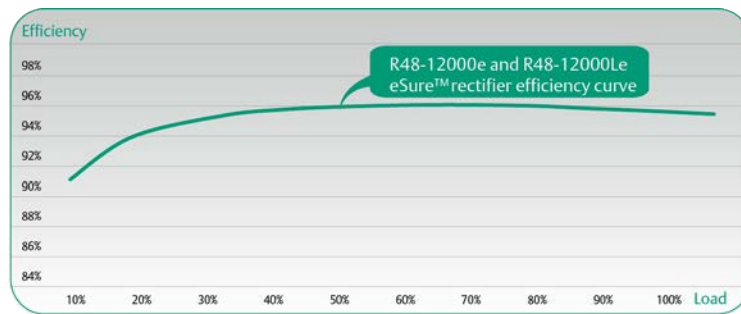

(C) Maximum input current at 100% of full load with output adjusted to 58 volts DC as measured at the output bus.

Nominal Input Voltage	Input Voltage	Number of Rectifiers Installed	Input Current (Amperes)
208	208	1	34.25
		2	68.50
		3	103.75
		4	138.00
		5	172.25
		6	206.75
		7	241.00
		8	275.25
		9	309.50
		10	343.75

3.4 Standard Features

3.4.1 Type of Power Conversion Circuit: High frequency.

3.4.2 Float Charging Output Mode: In this mode of operation, system output voltage is constant and output current does not exceed the current limit setting. During normal operation, the battery is not required to furnish load current and remains in a fully charged condition.

Note: If the current demanded by the load exceeds the current limit setting of the system, the battery is required to furnish the difference in load current and begins discharging.

Note: If the system is used with a digital battery charge temperature compensation probe, the controller automatically adjusts system output. This ensures proper voltage to the battery as battery ambient temperature fluctuates.

3.4.3 Test/Equalize Charging Output Mode: This mode of operation is used if higher output voltage is required for equalizing the charge on all battery cells of a conventional flooded cell battery, or for recharging the battery following a commercial power failure.

If the installation site does not require system equalize mode of operation, the equalize feature can be used as a test feature. System equalize voltage can be adjusted to a test voltage value. Placing the system into the test/equalize mode causes system output voltage to increase or decrease to this test voltage value.

Note: *If the system is used with a battery charge temperature compensation probe, typical equalize mode of operation is not used.*

3.4.4 Input Protection: List 101 and List 111 provide connections for up to ten AC input branch circuits, one per rectifier mounting position. Customer to provide AC input branch circuit protection.

List 102 and List 112 must be used with a PDSC (AC Input 'Power Distribution Service Cabinet'). This cabinet provides connections for one or two AC input branch circuits. A 30 ampere AC input circuit breaker with an interrupting capacity of 22kA (List 130) or 65kA (List 131) amperes at 480 volts AC is provided for each rectifier mounting position.

(A) Low AC Input Voltage Inhibit: If AC input voltage decreases to a preset non-adjustable value, the rectifier's power conversion circuitry inhibits, disabling system output. When AC input voltage increases to another preset non-adjustable value, the system automatically restarts.

(1) 480VAC Input (R48-12000e): Designed to inhibit at approximately 255 volts AC, and to restart at approximately 260 volts AC.

(2) 208VAC Input (R48-12000Le): Designed to inhibit at approximately 138 volts AC, and to restart at approximately 157 volts AC. (Note: In the range of 140 to 180V, the output is de-rated to 50%.)

(B) High AC Input Voltage Inhibit: If AC input voltage increases to a preset non-adjustable value, the rectifier's power conversion circuitry inhibits, disabling system output. When AC input voltage decreases to another preset non-adjustable value, the system automatically restarts.

(1) 480VAC Input: Designed to inhibit at approximately 550 volts AC, and to restart at approximately 535 volts AC.

(2) 208VAC Input: Designed to inhibit at approximately 264 volts AC, and to restart at approximately 250 volts AC.

(C) Phase Loss: If any of the three phases of the AC input voltage decreases below the lower limit or increases above the upper limit in Paragraph 3.2.1, the rectifier's power conversion circuitry inhibits, disabling system output. When the phase is restored, the system automatically restarts.

3.4.5 Output Protection

(A) Current Limiting: The maximum current delivered by the system can be programmed from 10% to 110% of total system capacity. The controller automatically adjusts the current limit circuit on each rectifier so that this value is not exceeded. If a rectifier fails, the controller automatically resets each remaining rectifier's current limit point to maintain this value. The controller also insures that the current limit circuit on any rectifier is not set above 110% of its capacity. The default current limit setting is the sum of each installed rectifier's output rating. If an additional rectifier is added to the system, the system current limit is automatically increased by the rating of the new rectifier and the new current limit value is displayed.

The current limiting point can be adjusted without removing a rectifier. One adjustment changes the setting of all rectifiers.

The current limit is factory set at 100% of rated full load, unless otherwise specified.

(B) Output Fusing: Output fusing is provided in each rectifier. If a fuse opens, local and remote rectifier Fail Alarms activate. This fusing is not customer replaceable.

(C) Thermal Current Limiting: Each rectifier continuously monitors the ambient temperature surrounding the power conversion unit circuit. If this temperature for any reason (such as a high ambient office temperature) increases above approximately +40°C (+104°F), the rectifier will not shut down. Rather, the rectifier will limit its maximum output current to maintain the temperature of the power conversion circuit within design parameters. Full current capability is restored when the temperature decreases to below approximately +40°C (+104°F). The following figure illustrates typical operating parameters.

Note: *If the current limit setting is greater than the maximum allowable output current for the existing room ambient temperature, the current limit setting will automatically be reduced. Refer to the following figure. Local and external indications will be given.*

Warning: *The rectifier is rated for continuous operation at full output current up to +40°C (+104°F). Operation between +40°C and +80°C (+104°F and +176°F) is considered abnormal and should be used on a temporary basis only.*

- ¹ Temporary Operation at Abnormal Temperature: Temporary operation refers to a period of not more than eight consecutive hours per day, and a total of not more than 15 days in a year. (This refers to a total of 120 hours in any given year, but no more than 15 occurrences in that one year period.)

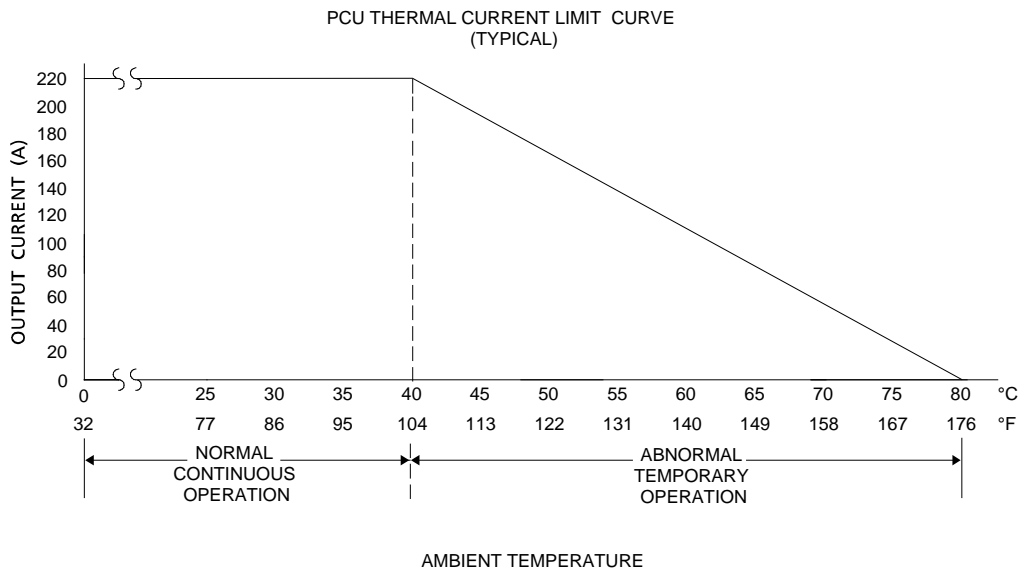

(D) High Temperature Inhibit: A thermal switch present in each rectifier continuously monitors the temperature of the power conversion circuit. If the temperature of the power conversion circuitry exceeds the design limits a circuit will inhibit the rectifier. Manual restart is then required.

(E) High Voltage Shutdown

- (1) Internal: If rectifier output voltage exceeds an adjustable preset value and is delivering more than 10% of its rated current, the rectifier shuts down.

After approximately 3 seconds, the rectifier automatically restarts. If rectifier output voltage again exceeds the high voltage shutdown value within 5 minutes, the rectifier shuts down and locks out. Manual restart is then required. If the rectifier does not experience a high voltage condition within the 5 minute time period, the restart circuit is reset.

If two or more rectifiers are installed in the power/distribution bay, or if the power/distribution bay is paralleled with other power/distribution bays, only the rectifier causing the high voltage condition shuts down.

The high voltage shutdown point can be checked and/or adjusted without removing a rectifier. One adjustment changes the setting of all rectifiers.

Adjustable from 48.00 to 59.50 volts DC. Factory set at 57.50 volts, unless otherwise specified.

- (2) Remote: See Paragraph 4.1.13 (B).

- (3) Backup: If rectifier output voltage exceeds a second (non-adjustable) value, the rectifier shuts down and locks out regardless of load. Manual restart is then required.

3.4.6 DC/DC Converter Failure: If a rectifier's DC/DC converter fails, the rectifier shuts down. After approximately 3 seconds, the rectifier automatically restarts. If a DC/DC converter failure condition occurs again within 5 minutes, the rectifier shuts down and locks out. Manual restart is then required. If the rectifier does not experience a DC/DC converter failure condition within the 5 minute time period, the restart circuit is reset.

3.4.7 Power Factor Corrector Converter Failure: If a rectifier's power factor corrector converter fails, the rectifier shuts down. After approximately 3 seconds, the rectifier automatically restarts. If a power factor corrector failure condition occurs again within 5 minutes, the rectifier shuts down and locks out. Manual restart is then required.

If the rectifier does not experience a power factor corrector failure condition within the 5 minute time period, the restart circuit is reset.

- 3.4.8 Thermal Shutdown: If the internal temperature of a rectifier exceeds the over temperature protection threshold, the rectifier shuts down. After approximately 3 minutes, the rectifier automatically restarts. If the internal temperature of the rectifier again exceeds the over temperature protection threshold within 30 minutes, the rectifier shuts down and locks out. Manual restart is then required. If the internal temperature of the rectifier does not exceed the over temperature protection threshold within the 30 minute time period, the thermal shutdown lockout circuit is reset.
- 3.4.9 Paralleling: This system may be connected in parallel with any rectifier of the same polarity and adjusted to the same output voltage.
- 3.4.10 Load Sharing: The controller load sharing feature automatically balances the load to within $\pm 3\%$ of the rectifiers rated output currents. If the controller's load sharing feature is disabled for any reason, pre-programmed slope control in each rectifier balances the load to within $\pm 10\%$ of their rated output currents. The controller will balance a system of up to 80 rectifiers within 5 minutes. Load sharing is enabled when the load is between 10% and 95% capacity. In Power Share applications, load sharing is enabled once the legacy plant is 100% loaded.
- 3.4.11 Output Current Walk-In: Output current gradually increases after the system is switched on, or AC service is supplied or restored as indicated below. Elapsed time is constant at 10.2 seconds.
- 3.4.12 Cooling: Each rectifier contains multiple fans for forced convection cooling. If one fan in a rectifier fails, the rectifier continues to operate but at reduced output current (maximum output current is reduced to 50% of rated output current). If two or more fans fail, the rectifier's power conversion circuitry inhibits.
- 3.4.13 Local Controls: Refer to the "Operating Procedures" chapter in the Power System User Instructions for a complete description.
- (A) Standby/Operate Switch
- 3.4.14 Local Status and Alarm Indicators: Refer to the "Operating Procedures" chapter in the Power System User Instructions for a complete description.
- (A) AC/Identification (Green)
 - (B) Rectifier Fail / Minor (Red / Yellow) (208V Rectifier)
 - (C) Protection Alarm (Yellow) (480V Rectifier)
 - (D) Fail Alarm (Red) (480V Rectifier)
 - (E) A 10-segment Green LED Indicator Bar is located on the front panel to represent output current, each segment represents 20A (blinks when in overload condition).

4. NCU CONTROLLER

4.1 Specifications

4.1.1 For NCU controller specifications, refer to the NCU controller instructions (UM1M830BNA).

4.2 Configuration

4.2.1 For NCU controller factory settings, refer to the NCU controller configuration drawing (C-drawing).

4.3 IB2 and EIB (NCU Interface Board) Ratings

4.3.1 Digital Input Ratings

- (A) Maximum Voltage Rating: 60V DC.
- (B) Active High: > 19V DC.
- (C) Active Low: < 1V DC.

4.3.2 Relay Ratings

- (A) Steady State: 0.5 A @ 60 VDC; 1 A @ 30 VDC.
- (B) Peak: 3 A @ 30 VDC.

4.4 SM-DUE Ratings

4.4.1 See Table 20.

Vertiv™ NetSure™ 8200 -48 VDC Power System
System Application Guide

Item	Description	
Input Power	Input voltage range: 19 VDC to 60 VDC. Maximum input non-destructive voltage: 75 VDC.	
Input Signals	Ten (10) Load Bus Voltage	Valid measurement voltage range: 0 VDC to 60 VDC.
	Ten (10) Load Fuse Alarm	Bus- base of 0 VDC, >10 VDC alarm, <10 VDC normal.
	Ten (10) Analog Inputs	Each can be set to accept one (1) of the following inputs: <ul style="list-style-type: none"> • 10 mV DC to 50 mV DC Load Shunt (only load shunts are supported at this time) • 0 mA to 20 mA General-Purpose Transducer • 0 VDC to 10 VDC General-Purpose Transducer • 1 uA/K Temperature Sensor
Output Signals	+5 VDC Output for External Hall Devices	
Communication	One (1) RS-485 Port (factory use only)	RS-485 isolated asynchronous port. Baud rate: 9600/19200 bps, set by hardware. Data format: N, 8, 1.
	One (1) CAN Bus Port	CAN baud rate: 125 Kbps.
Environmental	Ambient Temperature	Normal: -10 °C to +65 °C. Non Destructive: -40 °C to +75 °C.
	Humidity	Less than 90% without condensation.
	Environment	Atmosphere free of dust, corrosive or explosive vapors, oily fumes, moisture, condensation, metallic particulates, and salinity.
	Altitude	Under 3000 meters.
	Cooling Mode	Air cooling without fan.
EMC	Complies with standards: EN 55022, EN 61000-4-6, EN 61000-4-2, EN 61000-4-4, EN 61000-4-5, and EN 61000-4-29.	
Safety	Complies with standards: EN60950, UL60950, GR-63, and GR-1089. Safety certifications: CE, UL. Meets the requirements of NEBS level 3.	

Table 20
SM-DUE General Technical Specifications

Vertiv™ NetSure™ 8200 -48 VDC Power System
System Application Guide

4.4.2 NCU Numbering Scheme: The NCU identifies (numbers) the components of the system as follows.

COMPONENT	NCU IDENTIFICATION NUMBER		
	NCU NUMBERING SCHEME	NOTES	EXAMPLE
Bay	Bay #	Primary Bay is #1, other bays are numbered consecutively, following the bay-to-bay cabling scheme.	Primary Bay 1 Second Bay 2 Fifth Bay 5
Rectifier	NCU Rectifier ID#	Rectifiers are identified as they are powered-up and recognized by the NCU.	First Recognized Rectifier Rectifier 1 Tenth Recognized Rectifier Rectifier 10
Distribution Bus (Power/ Distribution Bays and Distribution Only Bays)	Bay # Top or Bottom Distribution	Primary Bay is #1, other bays are numbered consecutively, following the bay-to-bay cabling scheme.	Primary Bay, Top Bus Bay 1 Top Dist Second Bay, Bottom Bus Bay 2 Bottom Dist Fifth Bay, Top Bus Bay 5 Top Dist
Distribution Device (Power/ Distribution Bays and Distribution Only Bays)	Load Bay # Distribution Point # within Bay	Primary Bay is #1, other bays are numbered consecutively, following the bay-to-bay cabling scheme. Distribution Point = 1-24 (left - right, Top Bus, Bus #1). 25-36 (left - right, Bottom Bus, Bus #2). Note that distribution components may take more than one mounting position, designation number is the left most mounting position.	Primary Bay, Circuit Breaker Mounted in Position One Load 1-1 Second Bay, Fuse Mounted in Position Sixteen Load 2-16 Fifth Bay, Plug-In Mounted in Position Twenty-Six Load 5-26

PHYSICAL SIZE INFORMATION

Overall Dimensions

Floor Hole Drilling Pattern Dimensions - Power/Distribution Bay and Power Only Bay (without AC Input Service Cabinet)

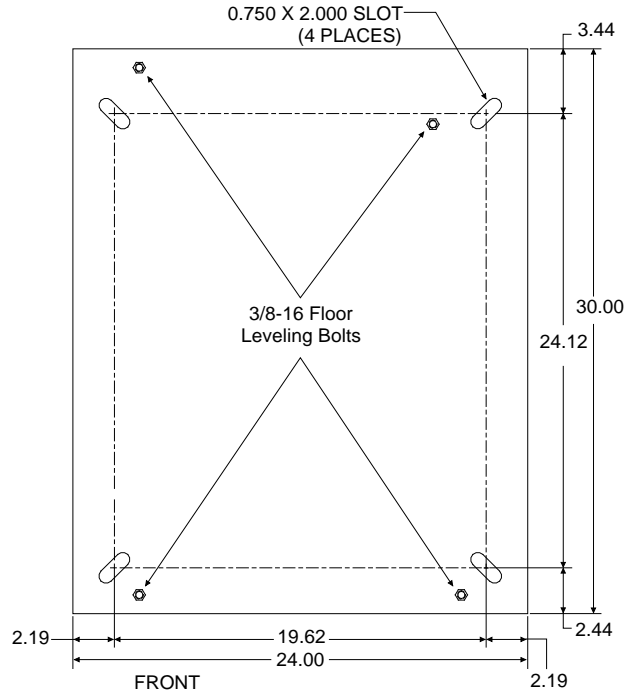

Floor Hole Drilling Pattern Dimensions - Power/Distribution Bay and Power Only Bay (with AC Input Service Cabinet)

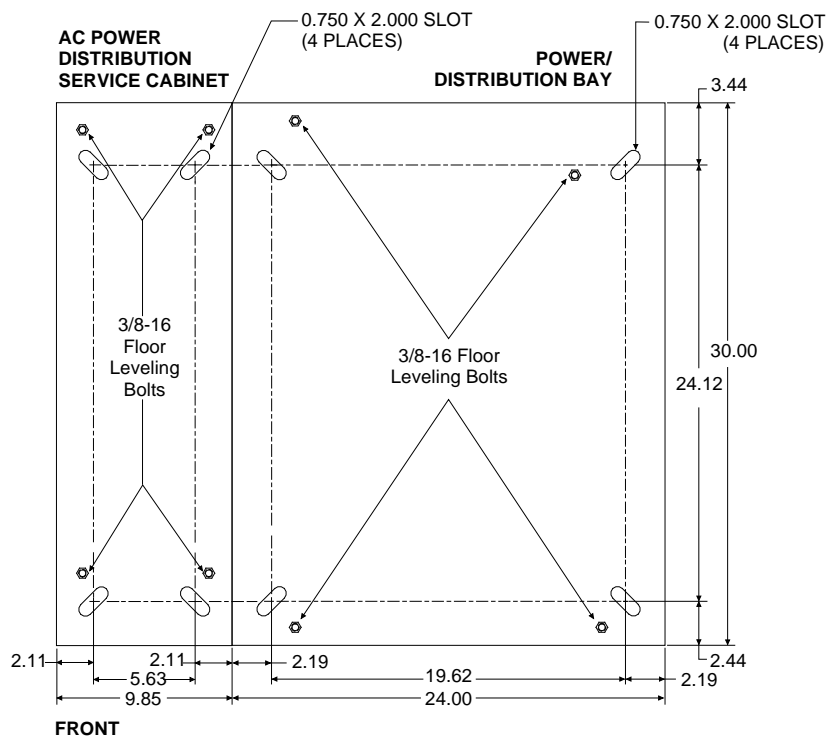

Floor Hole Drilling Pattern Dimensions - Distribution Only Bay

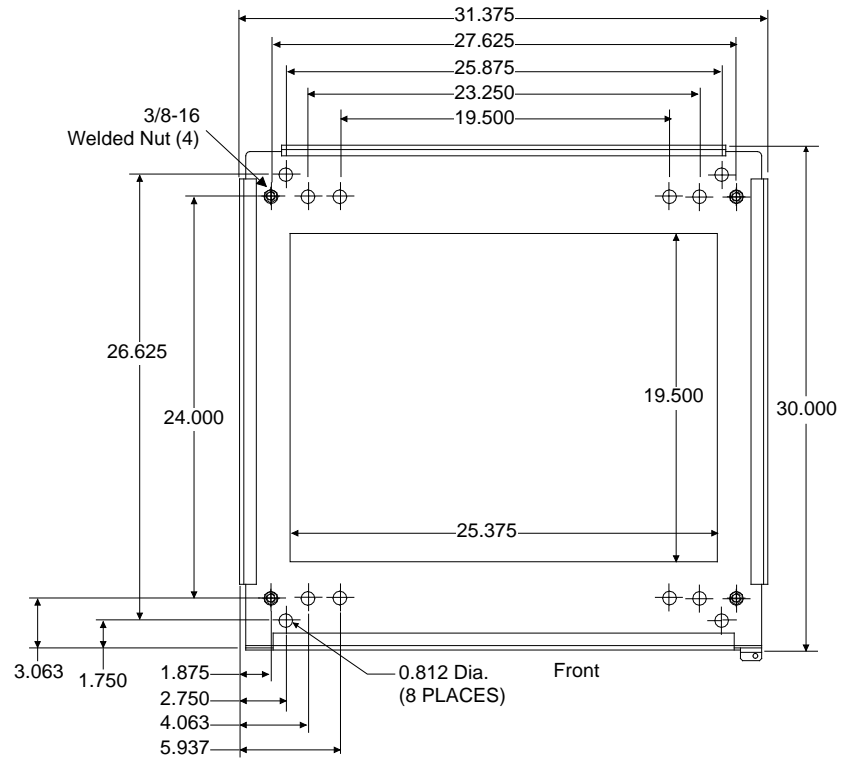

Vertiv™ NetSure™ 8200 -48 VDC Power System
System Application Guide

Primary and Secondary Power/Distribution Bays (List 101, 111)

AC Input Wiring Access Opening(s) →
Choose either the supplied access plate with ten 3/4" conduit openings, or ten 1" conduit openings.

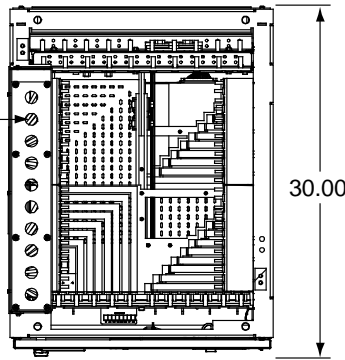

Top View

Notes:

1. All dimensions are in inches unless otherwise specified.
2. Weight in Lbs:
Bay
 Net: 746
 Shipping: 823
Rectifier
 Net: 41
 Shipping: 53
3. Finish: Gray

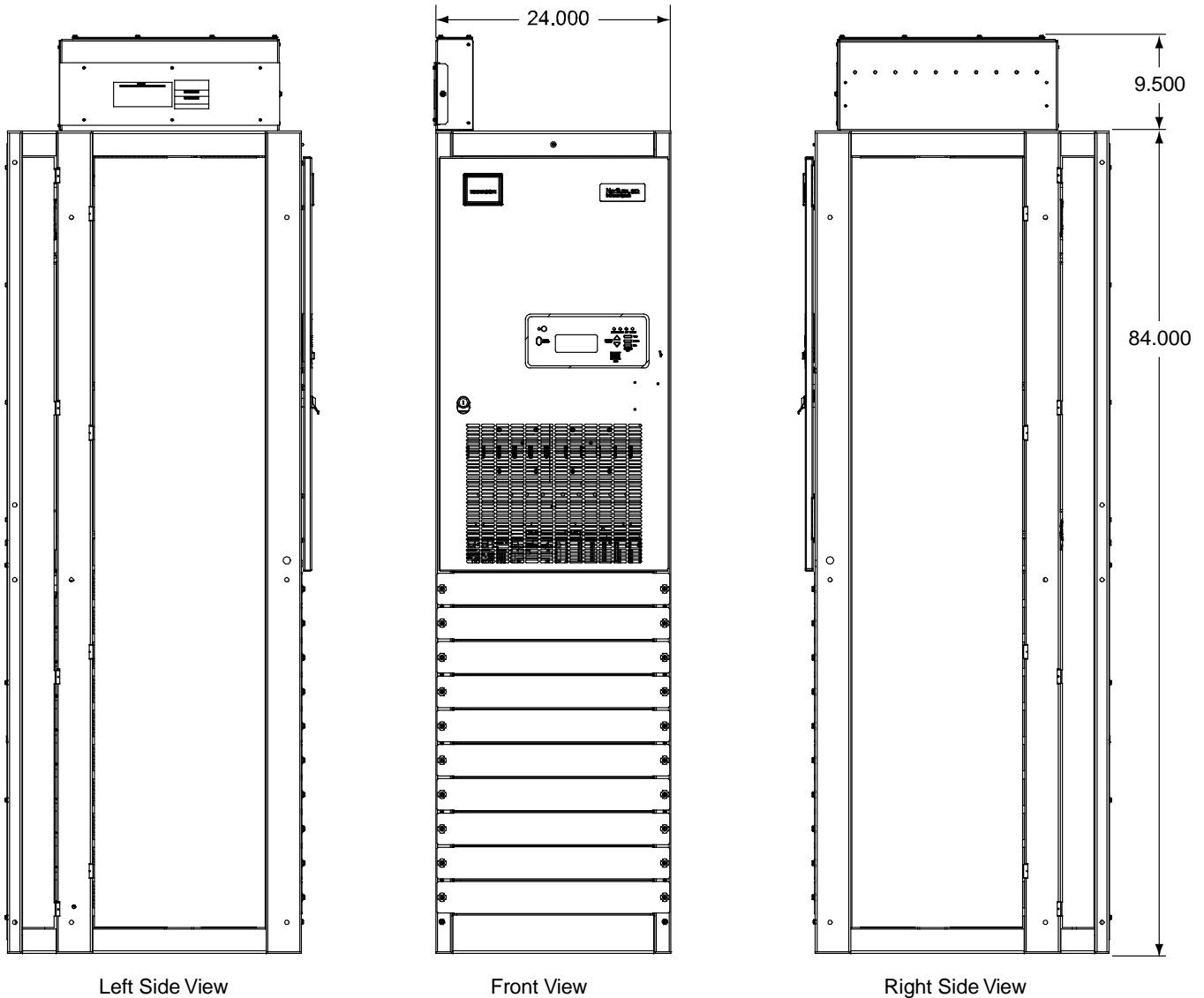

Left Side View

Front View

Right Side View

Vertiv™ NetSure™ 8200 -48 VDC Power System
System Application Guide

Primary and Secondary Power/Distribution Bays (List 102, 112)

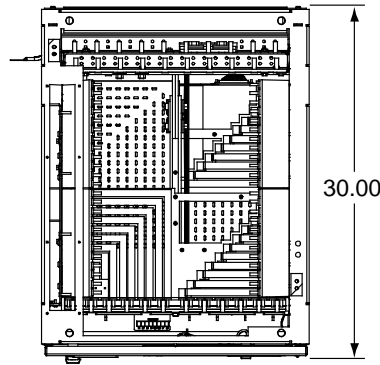

Top View

Notes:

1. All dimensions are in inches unless otherwise specified.
2. Weight in Lbs:
 Bay
 Net: 746
 Shipping: 823
 Rectifier
 Net: 41
 Shipping: 53
3. Finish: Gray

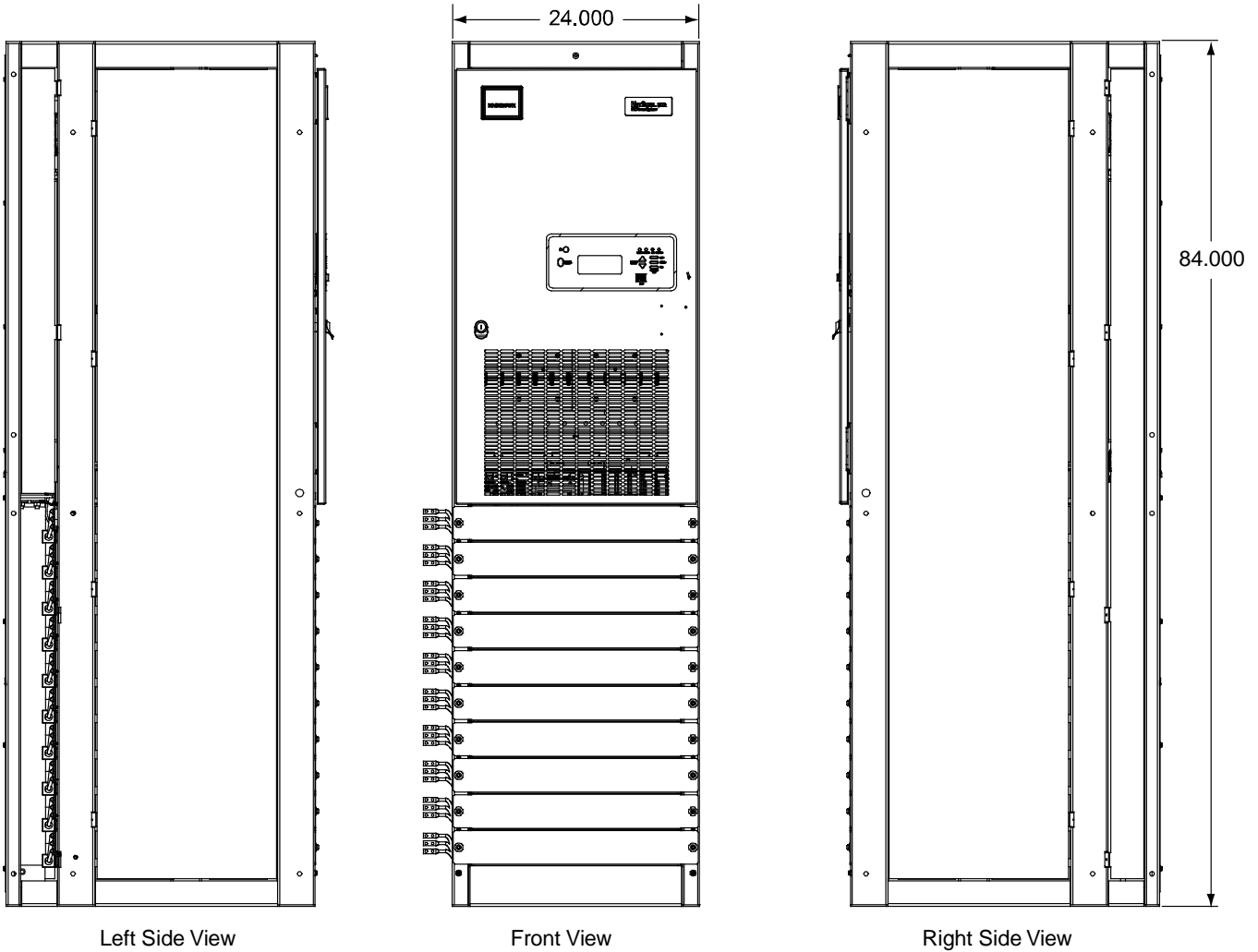

Left Side View

Front View

Right Side View

Vertiv™ NetSure™ 8200 -48 VDC Power System
System Application Guide

(AC Input 'Power Distribution Service Cabinet')

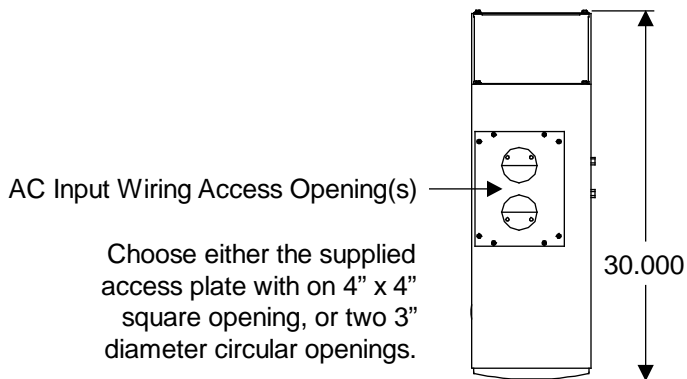

Notes:

1. All dimensions are in inches unless otherwise specified.
2. Weight in Lbs:
Net: 215
Shipping: 292
3. Finish: Gray

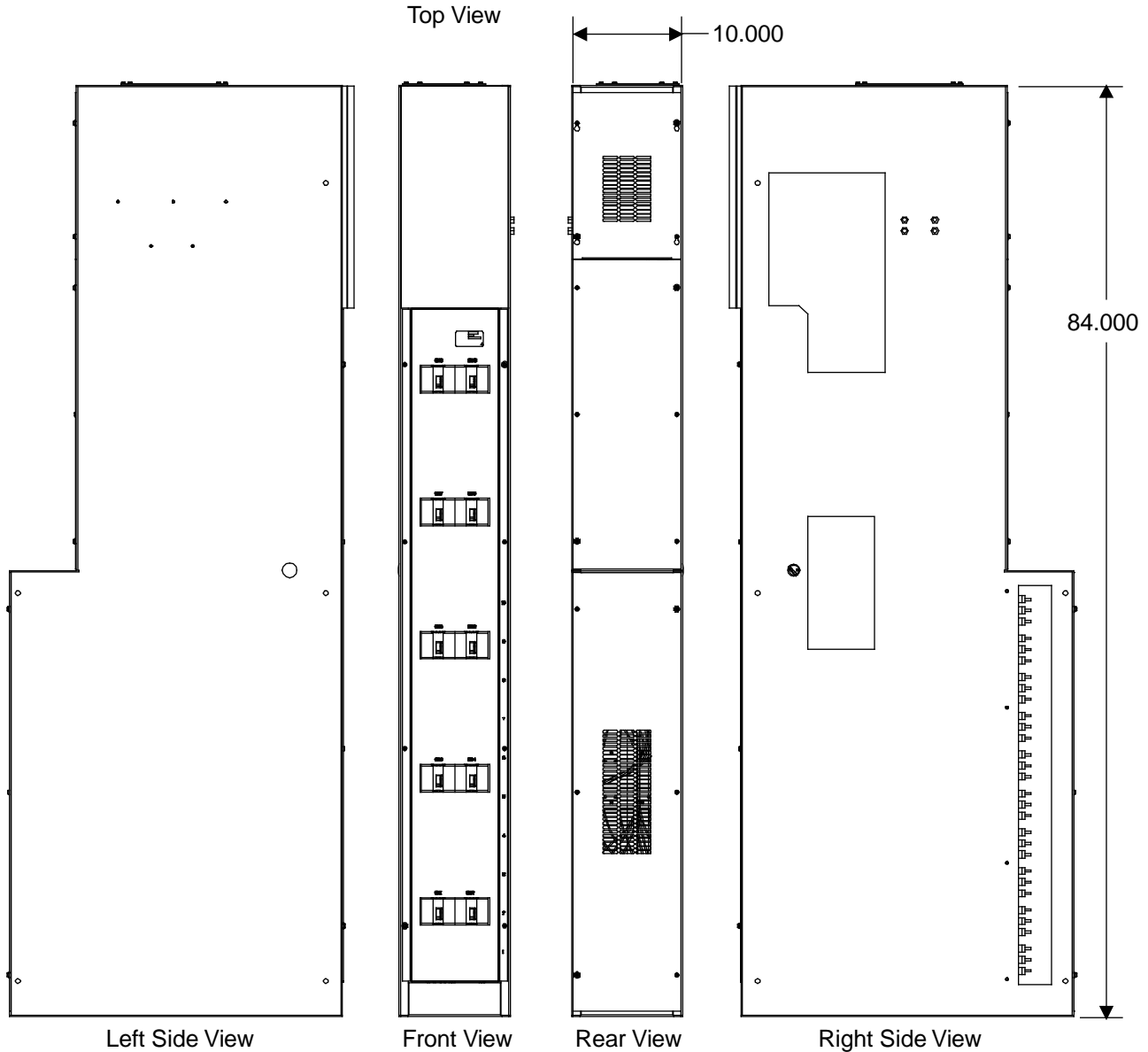

Vertiv™ NetSure™ 8200 -48 VDC Power System
 System Application Guide

Primary and Secondary Power Only Bays (List 103, 104, 105, 113, 114, 115)

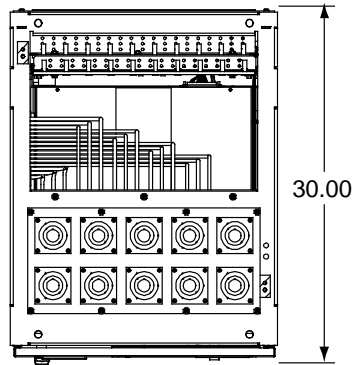

- Notes:
1. All dimensions are in inches unless otherwise specified.
 2. Weight in Lbs:
 Bay
 Net: 644
 Shipping: 721
 Rectifier
 Net: 41
 Shipping: 53
 3. Finish: Gray

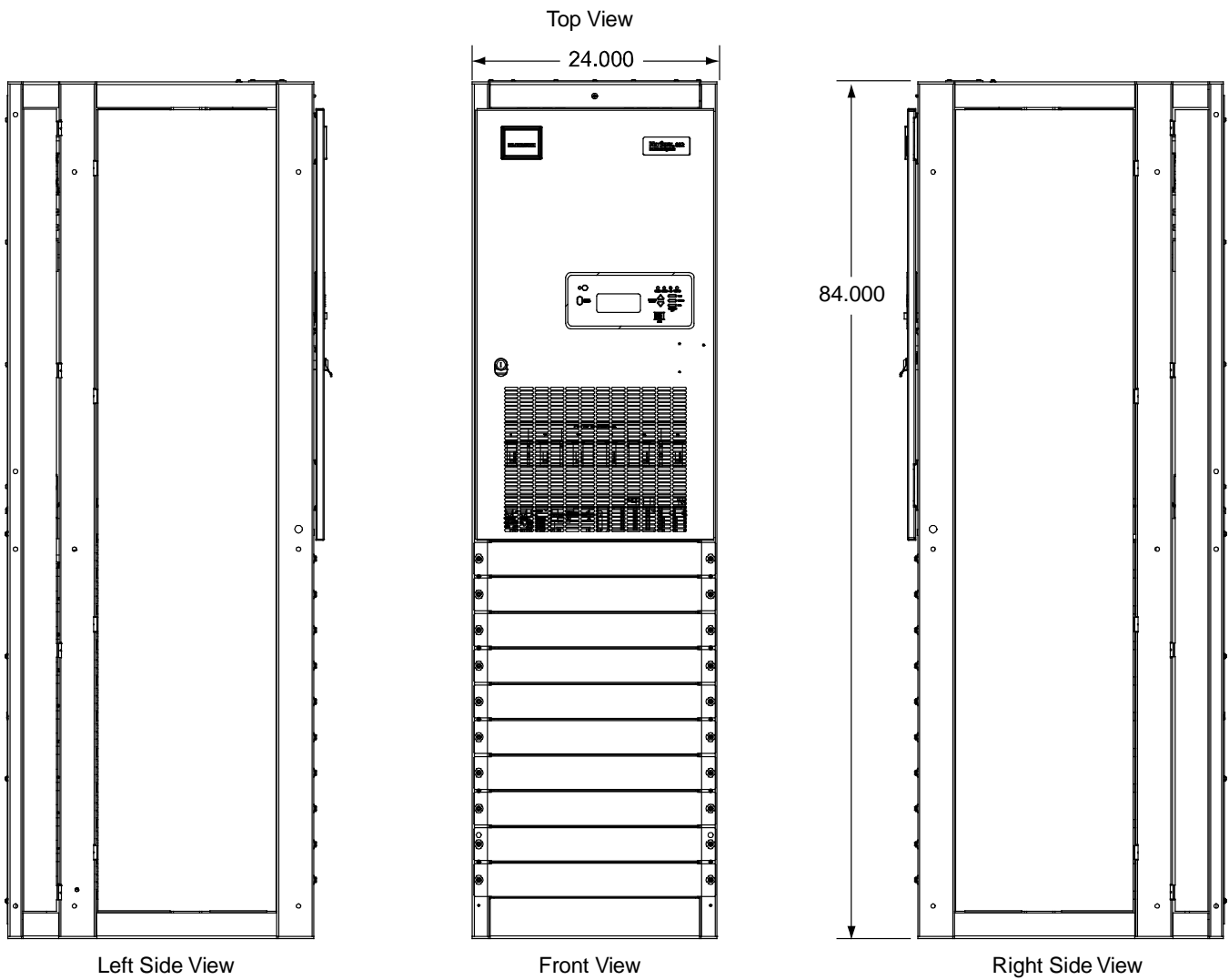

Vertiv™ NetSure™ 8200 -48 VDC Power System System Application Guide

Distribution Only Bays (List 116, 117, 118, 122)

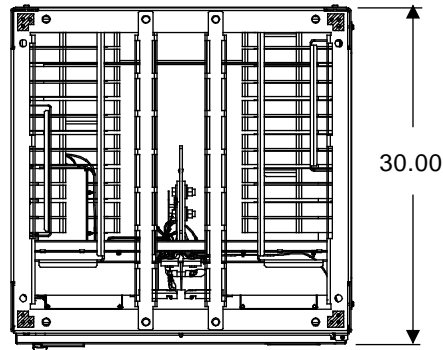

Top View

Notes:

1. All dimensions are in inches unless otherwise specified.
2. Weight in Lbs:
Net: 916
Shipping: 972
3. Finish: Gray

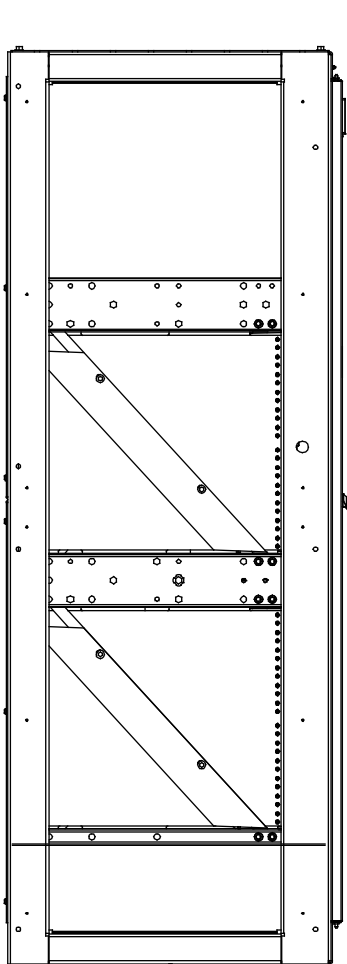

Left Side View

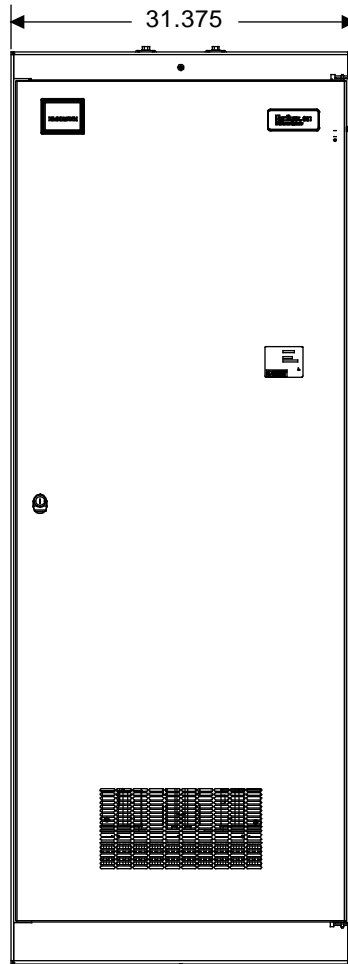

Front View

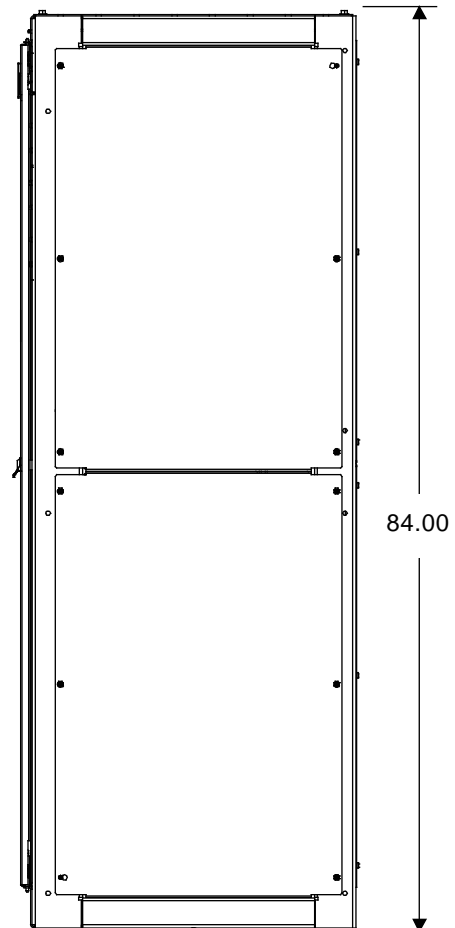

Right Side View

Vertiv™ NetSure™ 8200 -48 VDC Power System System Application Guide

Optional Temperature Probes (List 101, 102, 103, 104, 105 Only)

Optional Temperature Probes P/N 552992 (10.3 meters, approximately 34 feet), P/N 556155 (3.3 meters, approximately 10.3 feet), P/N 04119122 (10 meters, approximately 33 feet)

The temperature sensor end of the probe contains a tab with a 5/16" clearance hole for mounting.

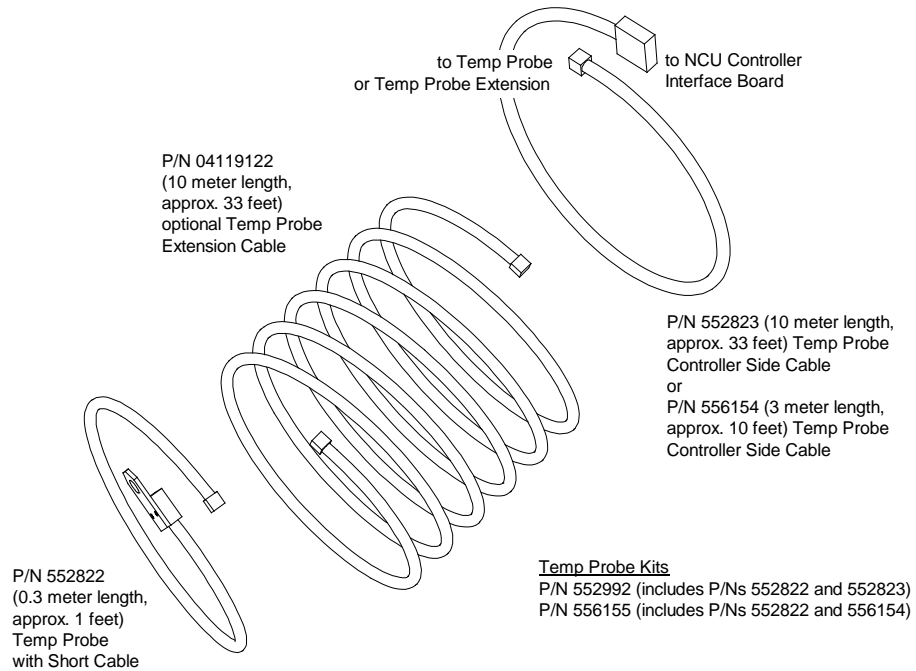

RELATED DOCUMENTATION

Models 8200NLDB, 8200NLEB and 8200NL-B

System Application Guide:	SAG582140000
System Installation Instructions:	IM582140000
System User Instructions:	UM582140000
NCU Controller Instructions:	UM1M830BNA
System Schematic Diagram:	SD582140000
System Wiring Diagram:	T582140000

Vertiv.com | Vertiv Headquarters, 505 N Cleveland Ave, Westerville, OH 43082, USA

© 2026 Vertiv Group Corp. All rights reserved. Vertiv™ and the Vertiv logo are trademarks or registered trademarks of Vertiv Group Corp. All other names and logos referred to are trade names, trademarks or registered trademarks of their respective owners. While every precaution has been taken to ensure accuracy and completeness here, Vertiv Group Corp. assumes no responsibility, and disclaims all liability, for damages resulting from use of this information or for any errors or omissions.

