



NetSure™ 802 Series NCU Retrofit Kit

Installation Manual

Kit Specification Number: 565406

For Use in Spec. No. 582140000 Power System (Primary Bay List 01, 02, 03, 04, 05)

The information contained in this document is subject to change without notice and may not be suitable for all applications. While every precaution has been taken to ensure the accuracy and completeness of this document, Vertiv assumes no responsibility and disclaims all liability for damages resulting from use of this information or for any errors or omissions. Refer to other local practices or building codes as applicable for the correct methods, tools, and materials to be used in performing procedures not specifically described in this document.

The products covered by this instruction manual are manufactured and/or sold by Vertiv. This document is the property of Vertiv and contains confidential and proprietary information owned by Vertiv. Any copying, use or disclosure of it without the written permission of Vertiv is strictly prohibited.

Names of companies and products are trademarks or registered trademarks of the respective companies. Any questions regarding usage of trademark names should be directed to the original manufacturer.

Technical Support Site

If you encounter any installation or operational issues with your product, check the pertinent section of this manual to see if the issue can be resolved by following outlined procedures.

Visit <https://www.vertiv.com/en-us/support/> for additional assistance.

TABLE OF CONTENTS

Admonishments Used in this Document	iv
Important Safety Instructions	v
Safety Admonishments Definitions.....	v
Safety and Regulatory Statements.....	v
Déclarations de Sécurité et de Réglementation.....	v
1 Vertiv™ NetSure™ 802 Series NCU Retrofit Kit Installation Instructions	1
1.1 Kit Description.....	1
1.2 Kit Contents.....	1
1.3 Tools and Material Required.....	1
1.4 Physical Security.....	2
1.5 Installation Procedure.....	2
1.6 Front Door Assembly Connector Locations.....	22
1.7 Control Shelf Connector Locations.....	23
1.8 Local Area Network (LAN) Ethernet Port Connection (IB5 Board).....	24
1.9 External Alarm, Reference, and Control Connections.....	25
1.9.1 IB2 (Controller Interface Board) Connections (if required).....	25
1.9.2 EIB (Controller Extended Interface Board) Connections (if required).....	31
2 Updated Customer Documentation Package	36

Admonishments Used in this Document



DANGER! Warns of a hazard the reader *will* be exposed to that will *likely* result in death or serious injury if not avoided. (ANSI, OSHA)



WARNING! Warns of a potential hazard the reader *may* be exposed to that *could* result in death or serious injury if not avoided. This admonition is not used for situations that pose a risk only to equipment, software, data, or service. (ANSI)



CAUTION! Warns of a potential hazard the reader *may* be exposed to that *could* result in minor or moderate injury if not avoided. (ANSI, OSHA) This admonition is not used for situations that pose a risk only to equipment, data, or service, even if such use appears to be permitted in some of the applicable standards. (OSHA)



ALERT! Alerts the reader to an action that *must be avoided* in order to protect equipment, software, data, or service. (ISO)



ALERT! Alerts the reader to an action that *must be performed* in order to prevent equipment damage, software corruption, data loss, or service interruption. (ISO)



FIRE SAFETY! Informs the reader of fire safety information, reminders, precautions, or policies, or of the locations of fire-fighting and fire-safety equipment. (ISO)



SAFETY! Informs the reader of general safety information, reminders, precautions, or policies not related to a particular source of hazard or to fire safety. (ISO, ANSI, OSHA)

Important Safety Instructions

Safety Admonishments Definitions

Definitions of the safety admonishments used in this document are listed under “Admonishments Used in this Document” on page iv.

Safety and Regulatory Statements

Refer to Section 4154 (provided with your customer documentation) for Safety and Regulatory Statements.

Déclarations de Sécurité et de Réglementation

Reportez-vous à la Section 4154 (fourni avec les documents de votre client) pour les déclarations de sécurité et de réglementation.

This page intentionally left blank.

1 Vertiv™ NetSure™ 802 Series NCU Retrofit Kit Installation Instructions

1.1 Kit Description

These instructions provide a step-by-step procedure to field install this kit into a Vertiv™ NetSure™ 802 Series DC Power System (Spec. No. 58214-0000, Primary Bay List 01, 02, 03, 04, 05). Installation of this kit in other equipment should not be attempted.

This kit replaces the MCA controller and LMS monitoring system in an older style system with the NCU controller that is offered in the latest revision system.

1.2 Kit Contents

Table 1.1 lists the items furnished as a part of this kit. Before installing the kit, check the items furnished against those listed to ensure that there are no shortages.

Table 1.1 Kit Contents

Qty.	P/N	Description
1	565402	Preassembled Main Control Shelf (and associated cables)
1	565576	Preassembled Front Door Assembly with Touchscreen (and associated cables)
1	1M830BNA565806	NCU Controller
1	534-715	Distribution Designation Label
4	237650200	Cable Tie
1	150661	USB Pouch with USB Drive
1	552423	Hook-and-Loop Fastener (factory attached to USB pouch)
1	10060553	Nameplate 58214-0000 (List B) for 208/240 VAC System
1	10060554	Nameplate 58214-0000 (List A) for 480 VAC System

1.3 Tools and Material Required

Table 1.2 lists the items required to install this kit.

Table 1.2 Tools and Material Required

Description
Nut Driver Set
#1 Phillips Screwdriver
#2 Phillips Screwdriver
Fine Tip Permanent Marker

1.4 Physical Security

This product is designed and intended to be deployed and operated in a physically secure and network firewall-protected location. Vertiv recommends a review of the physical security and operating environment of the unit. Since an attacker or disgruntled user can cause serious disruption, below are some recommended best practices that include, but are not limited to:

- Restrict access to areas, racks, and units with encrypted card RFID/badges, unique multi-factor passcode authentication for access, man traps, and biometric scanners for physical access to the equipment.
- Have trusted and background-checked security guards with 24x7x365 physical presence and written logs to help document and note physical access to a data center, building, rack, and so on.
- Restrict physical access to telecommunications equipment and network cabling. Physical access to the telecommunications lines and network cabling should be restricted to protect against attempts to intercept or sabotage communications. Best practices include use of metal conduits for the network cabling running between equipment cabinets.
- All USB, RJ45, and/or any other physical ports should be restricted on the units.
- Do not connect removable media (such as USB devices, SD cards, and so on) for any operation (such as firmware upgrade, configuration change, or boot application change) unless the origin of media is known and trusted. Before connecting any portable device through a USB port or SD card slot, scan the device for malware and viruses.

1.5 Installation Procedure

THESE INSTRUCTIONS SHOULD BE READ THROUGH COMPLETELY BEFORE INSTALLING THE KIT.

The following is a step-by-step procedure to install the kit. The procedure has been written for ease of use and to minimize the possibility of contact with potentially hazardous energy. This procedure should be performed in the sequence given, and each step should be completely read and fully understood before performing that step. Observe all “Important Safety Instructions” starting on page v and also those presented in the following procedure. As each step of the procedure is completed, the box adjacent to the respective step should be checked. This will minimize the possibility of inadvertently skipping any steps. If the step is not required to be performed for your site, also check the box to indicate that it was read.



DANGER! This kit can be installed with the system operating. Observe the “Important Safety Instructions” starting on page v and those listed in the power system manual.



CAUTION! When performing any step in procedures that requires removal or installation of hardware, use caution to ensure no hardware is dropped and left inside the unit; otherwise service interruption or equipment damage may occur.



NOTE! When performing any step in this procedure which requires removal of existing hardware, retain all hardware for use in subsequent steps, unless otherwise stated.

Initial Procedure

1. Performing this procedure may activate external alarms. Do one of the following. If possible, disable these alarms. If these alarms cannot be easily disabled, notify the appropriate personnel to disregard any future alarms associated with this system while the procedure is being performed.
2. Open the front door of the bay.
3. Record the LMS network address settings for later configuration of the NCU network parameters. See the following page from the LMS user manual.

IP Command

Description: Display information regarding the user configurable IP Network variables.

Command Level: 6

Syntax: IP

Comments: This command displays all the relevant IP information.

Notes: If the **Network Address**, **Netmask**, or **Gateway Address** is 0.0.0.0, the address will be displayed as **NONE**. If there are no hosts on the access list, the command displays:

No host access list. Unrestricted access granted.

The authorized host list is the list of remote computers permitted to access the system via **telnet**, **TFTP**, or **SNMP**. Hosts are identified on the list by their IP address. The list supports a maximum of 32 entries.

If there are no hosts on the list, access is granted to any computer attempting to connect to the system.

Related Commands:

- IP ADDRESS
- IP DELETE
- IP GATEWAY
- IP HOST
- IP NETMASK

Example:

```
Command<6> : IP
  IP Network Address : 216.32.74.51
  IP Gateway Address : 216.32.74.1
  IP Netmask         : 255.255.255.0
  Ethernet Address   : 00:0C:0A:60:12:2C
  IP Authorized Hosts : 216.32.74.42
                     216.32.74.43
```

Removing the Existing Front Door Procedure

- [] 1. Disconnect the wire harness connector to separate the existing front door wire harness from the system wire harness. See Figure 1.1.
- [] 2. Disconnect the existing front door grounding lead from the bay. See Figure 1.1.
- [] 3. While supporting the existing front door, slide the existing front door hinge latches into the slots to allow the door to be removed. Remove the existing front door. The existing front door will not be reused. See Figure 1.1.

Figure 1.1 Removing Existing Front Door

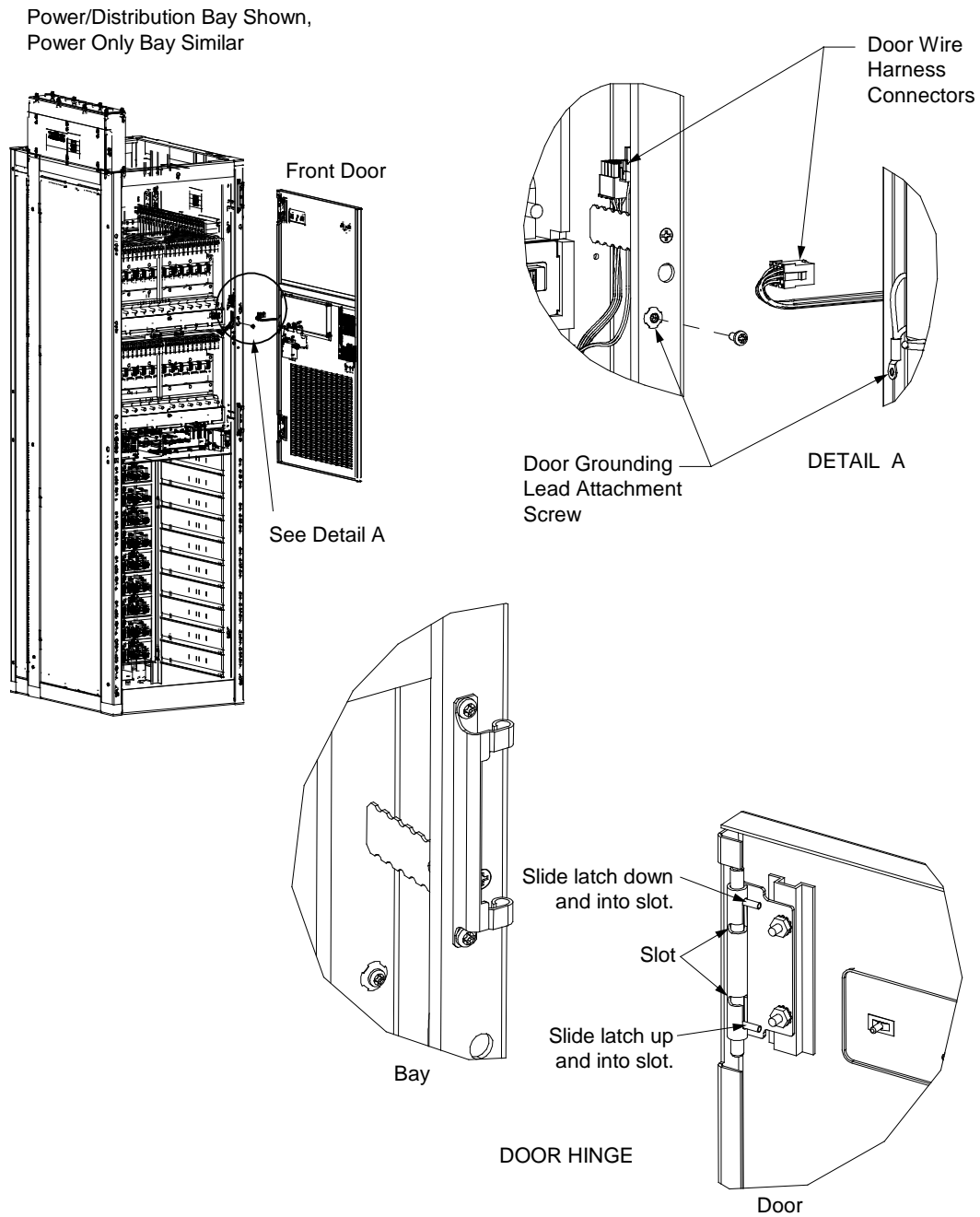

Installing the Kit Furnished Front Door Procedure

- [] 1. Slide the hinge latches on the new door into the slots. Place the new door onto the mating hinge halves of the bay. Slide the hinge latches on the new door out of the slots to secure the door to the bay. See Figure 1.2.
- [] 2. Reconnect the new front door grounding lead to the bay. Torque to 31 in-lbs. See Figure 1.2.
- [] 3. The existing bay wire harness will not be reconnected to the new door.

Figure 1.2 New Front Door Assembly

Power/Distribution Bay Shown,
Power Only Bay Similar

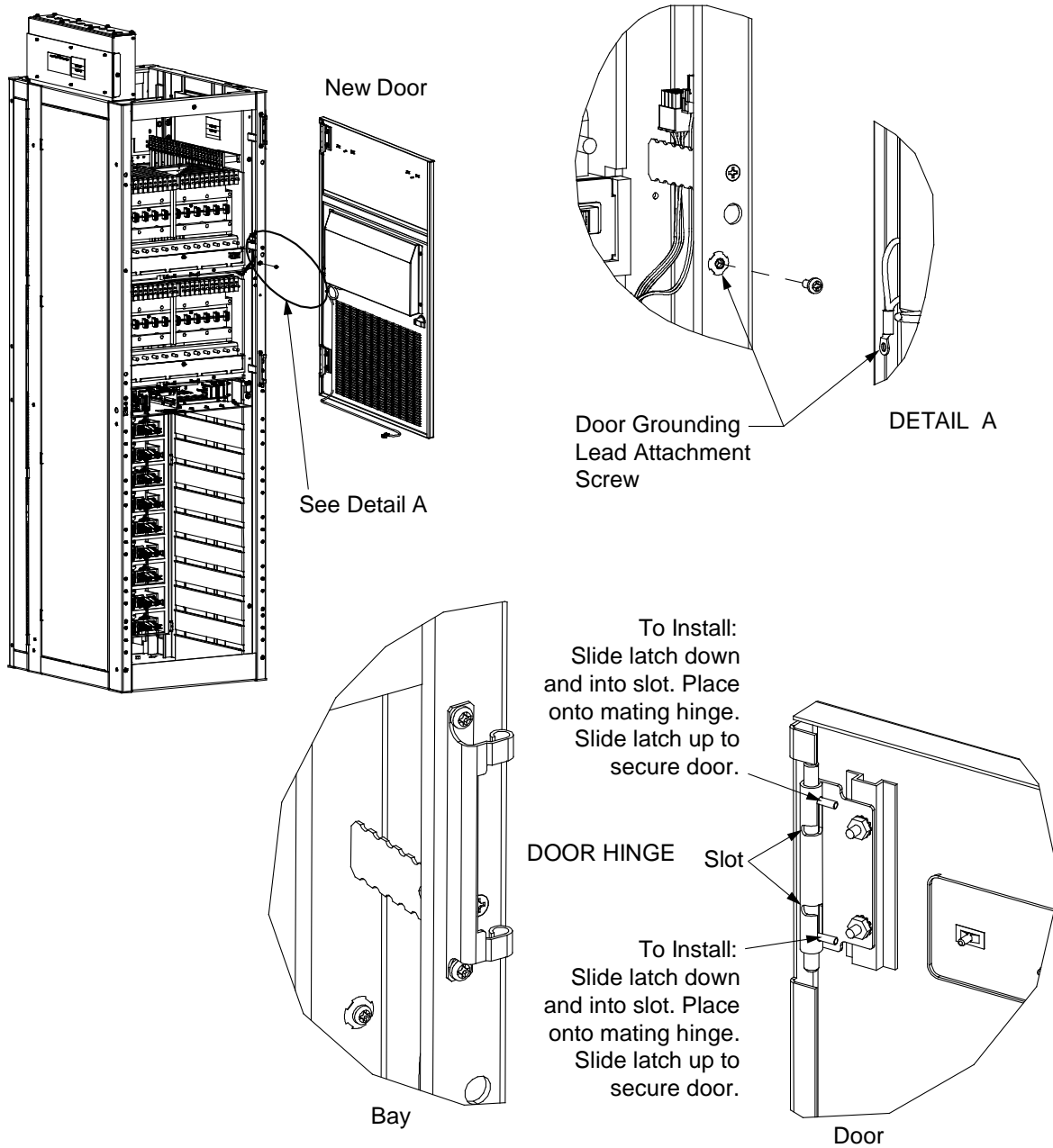

- [] 4. Write the information on the new nameplate from the old door nameplate by using fine tip permanent marker. See Figure 1.3 and Figure 1.4.



NOTE! If the system is 208/240 VAC system, use P/N 10060553 Nameplate 582140000 (List B) and if the system is 480 VAC system, use P/N 10060554 Nameplate 582140000 (List A).

- [] 5. Adhere the new nameplate on the new front door. Refer to Figure 1.5 for the location.

Figure 1.5 Location for the Nameplate

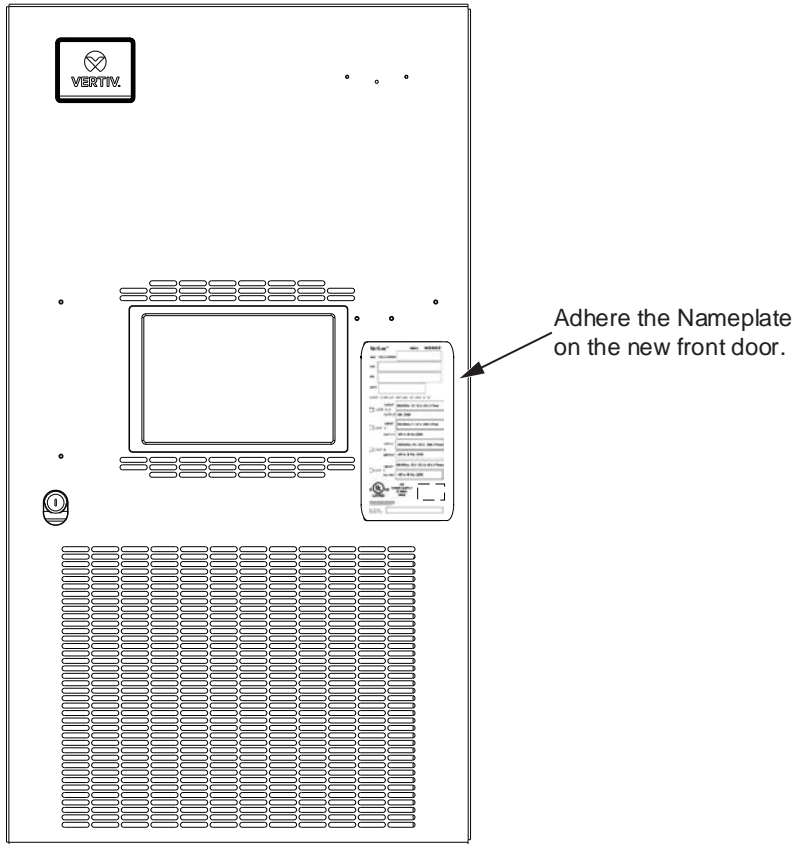

Removing the Existing System Monitoring and Control Shelf (MCA and LMS) Procedure

- [] 1. Label each cable attached to the Monitor and Control Shelf. See Figure 1.6 through Figure 1.13.
- [] 2. Disconnect and insulate each cable.
- [] 3. Remove the System Monitoring and Control Shelf (MCA and LMS). See Figure 1.14.

Figure 1.6 Removing Cables

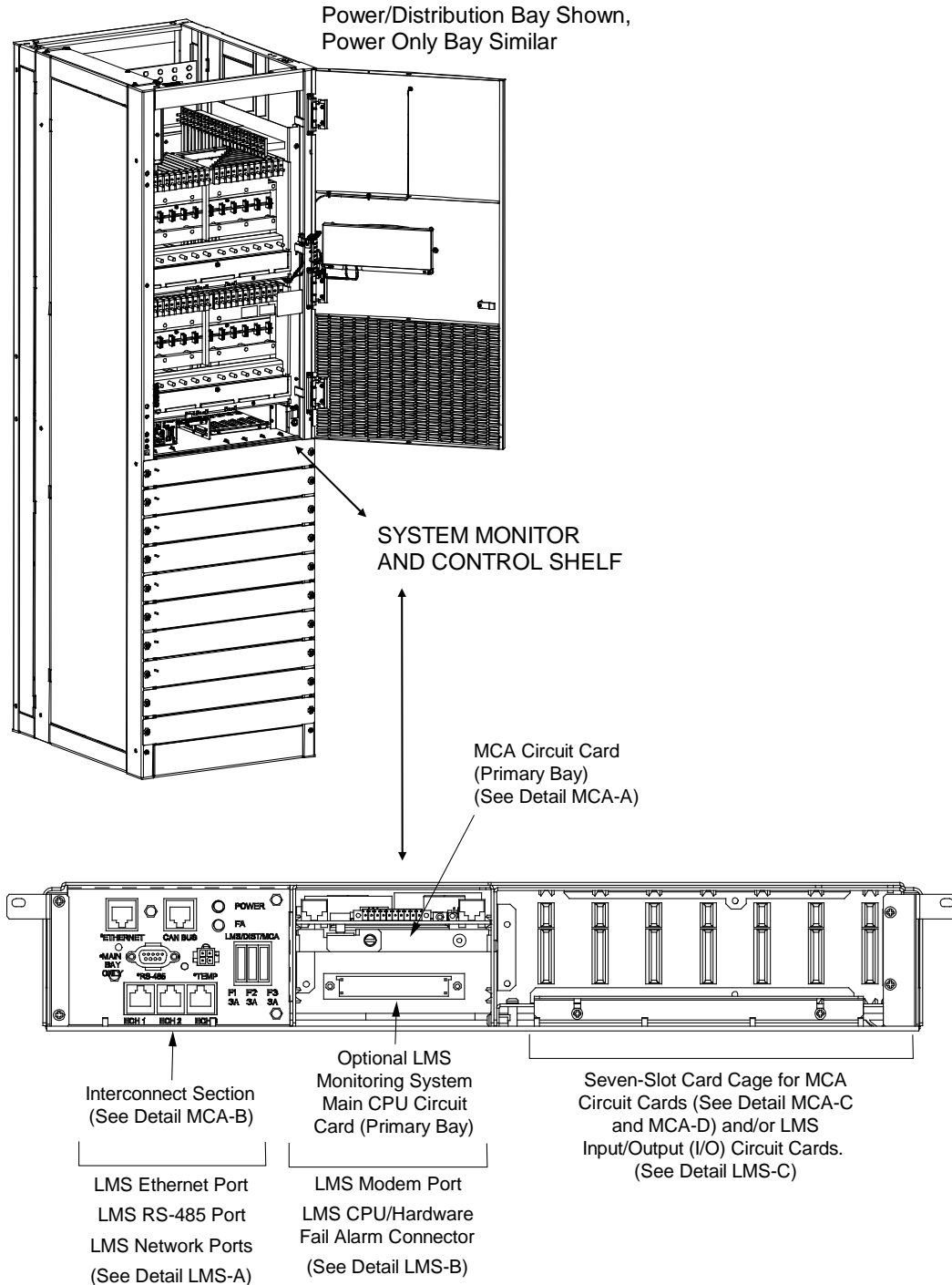
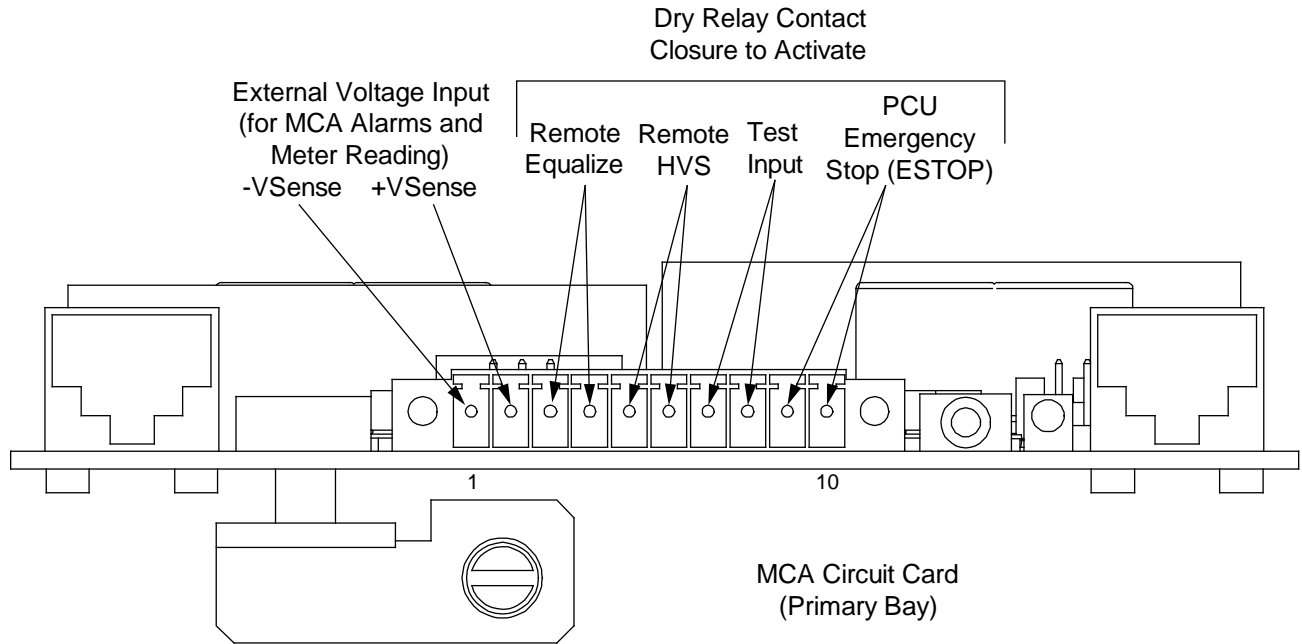

Figure 1.7 Removing Cables – Detail MCA-A

Detail
MCA-A

DISCONNECT AND REMOVE THESE LEADS FROM THE BAY OR INSULATE AND TIE BACK THESE LEADS PER YOUR COMPANY POLICIES. THESE LEADS WILL NOT BE RECONNECTED TO THE BAY, EXCEPT ESTOP IF REQUIRED.



REMOVE THIS CABLE. SAVE FOR LATER RE-USE.

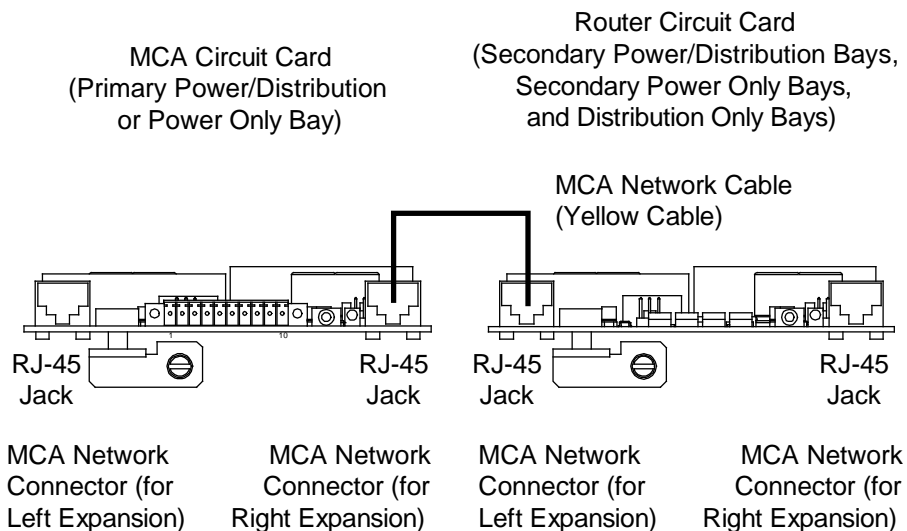

Figure 1.8 Removing Cables – Detail MCA-B

DISCONNECT AND REMOVE THESE LEADS FROM THE BAY OR INSULATE AND TIE BACK THESE LEADS PER YOUR COMPANY POLICIES. THESE LEADS WILL NOT BE RECONNECTED TO THE BAY.

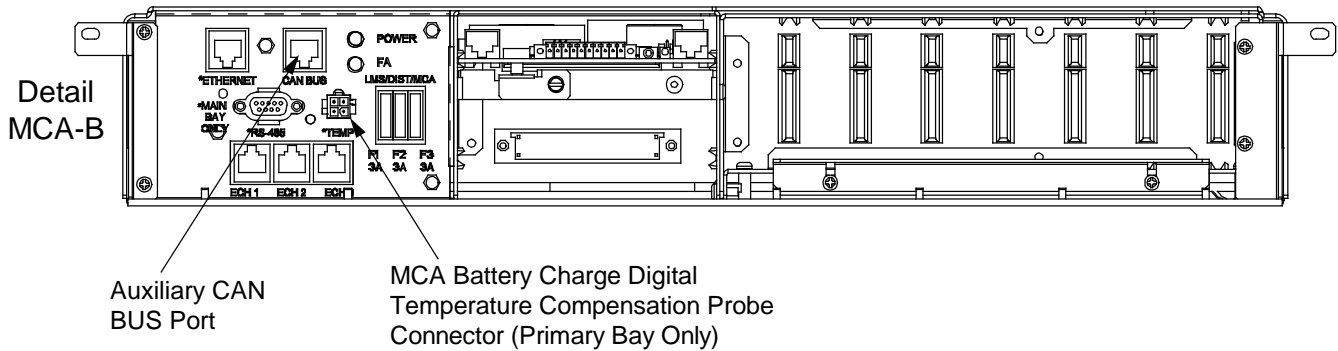
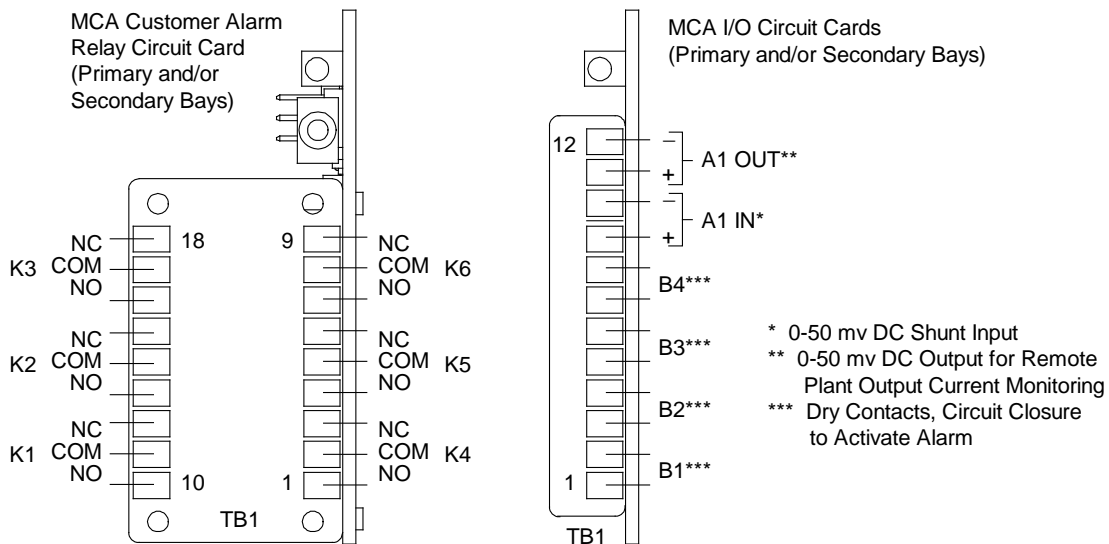

Figure 1.9 Removing Cables – Detail MCA-C

IF THESE LEADS WILL NOT BE REUSED:
DISCONNECT AND REMOVE THESE LEADS FROM THE BAY OR INSULATE AND TIE BACK THESE LEADS PER YOUR COMPANY POLICIES.

IF THESE LEADS WILL BE RECONNECTED TO THE NCU INTERFACE CARDS:
LABEL THE LEADS THEN TEMPORARILY DISCONNECT, INSULATE, AND TIE BACK THESE LEADS.

EXISTING MCA TEMPERATURE PROBES ARE NOT COMPATIBLE WITH THE NCU AND NEW PROBES MUST BE INSTALLED. SEE SAG582140000 FOR ORDERING DETAILS.



Detail MCA-C

Figure 1.10 Removing Cables – Detail MCA-D

IF THESE LEADS WILL NOT BE REUSED:
 DISCONNECT AND REMOVE THESE LEADS FROM THE BAY OR INSULATE
 AND TIE BACK THESE LEADS PER YOUR COMPANY POLICIES.

IF THESE LEADS WILL BE RECONNECTED TO THE NCU INTERFACE CARDS:
 LABEL THE LEADS THEN TEMPORARILY DISCONNECT, INSULATE, AND TIE
 BACK THESE LEADS.

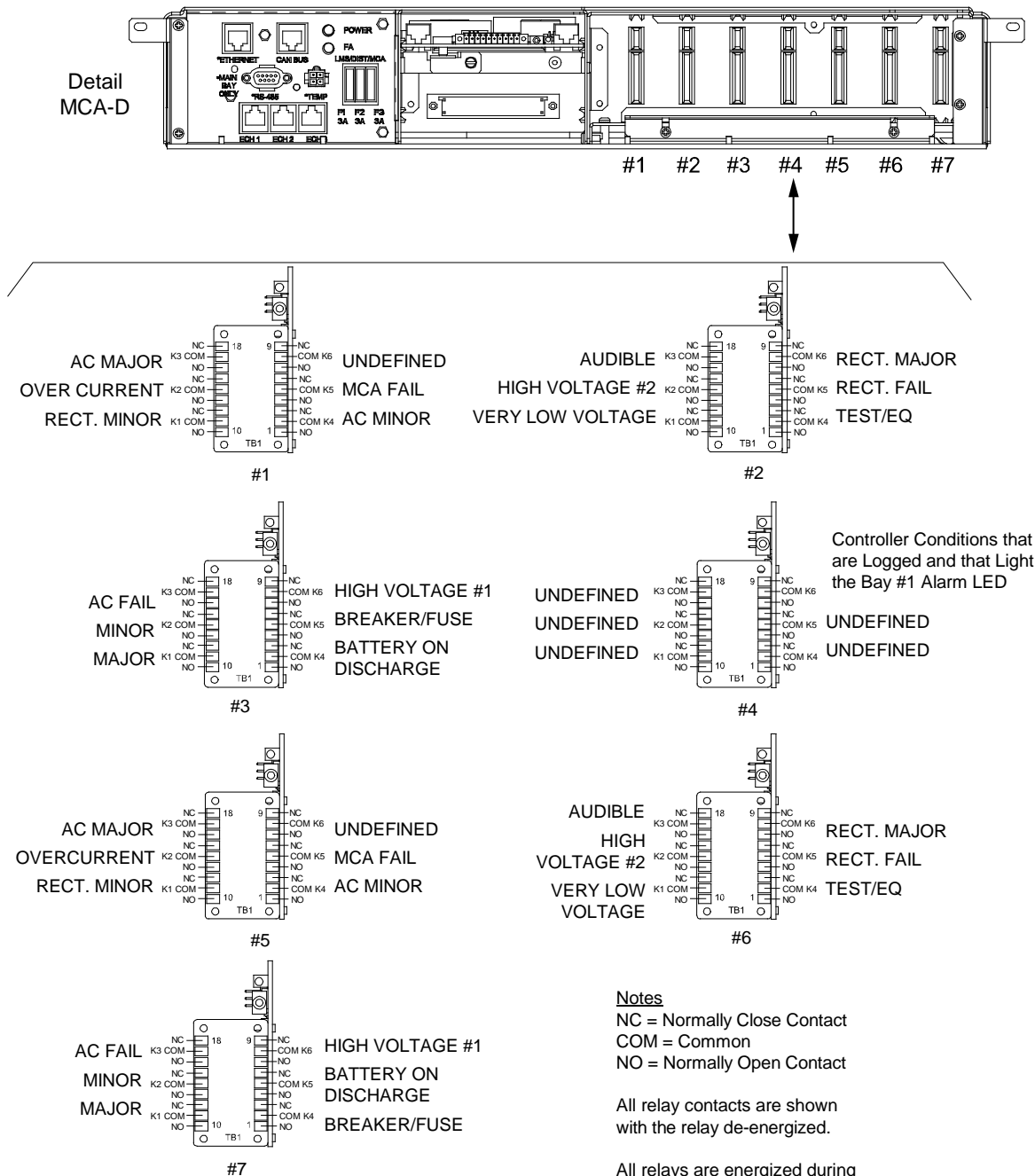

Notes
 NC = Normally Close Contact
 COM = Common
 NO = Normally Open Contact

All relay contacts are shown with the relay de-energized.

All relays are energized during normal operation, and de-energized during an alarm condition.

Figure 1.11 Removing Cables – Detail LMS-A

Detail LMS-A

DISCONNECT AND REMOVE THESE LEADS FROM THE BAY OR INSULATE AND TIE BACK THESE LEADS PER YOUR COMPANY POLICIES. THESE LEADS WILL NOT BE RECONNECTED TO THE BAY, EXCEPT THE ETHERNET PORT CABLE, IF REQUIRED.

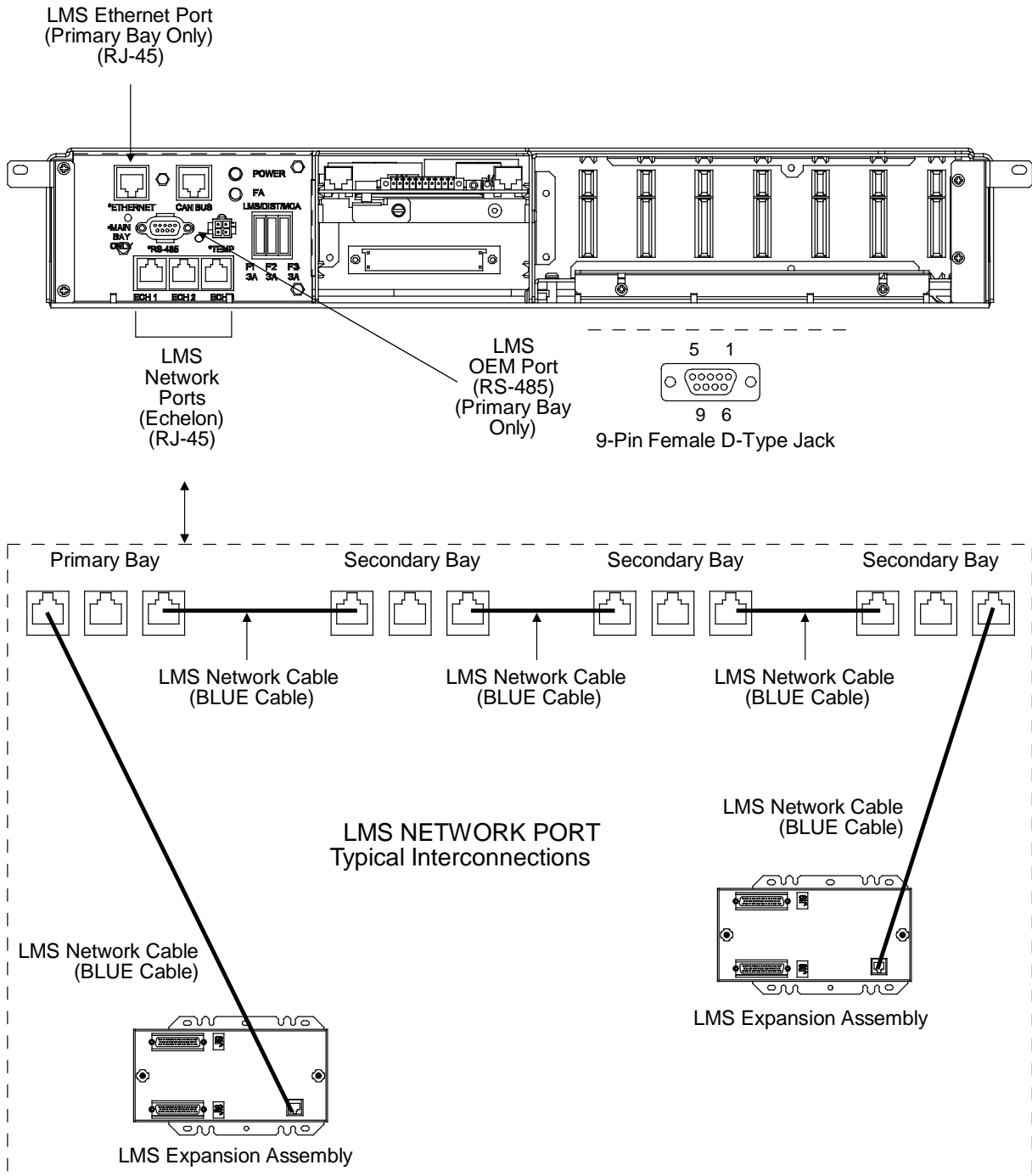
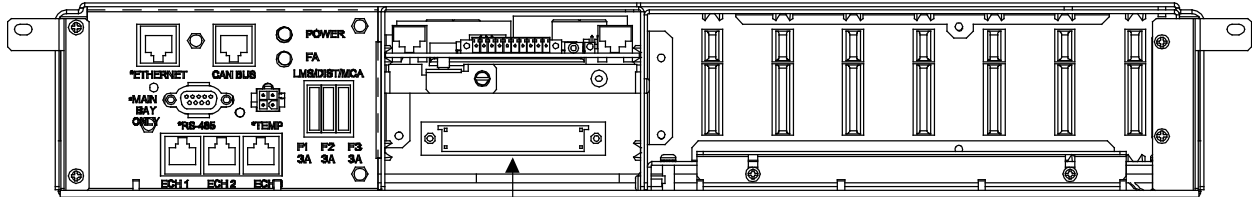

Figure 1.12 Removing Cables – Detail LMS-B

Detail LMS-B

DISCONNECT AND REMOVE THESE LEADS FROM THE BAY OR INSULATE AND TIE BACK THESE LEADS PER YOUR COMPANY POLICIES. THESE LEADS WILL NOT BE RECONNECTED TO THE BAY.



LMS Monitoring System
Main CPU Circuit Card
(P/N 545558)
(Primary Bay Only)

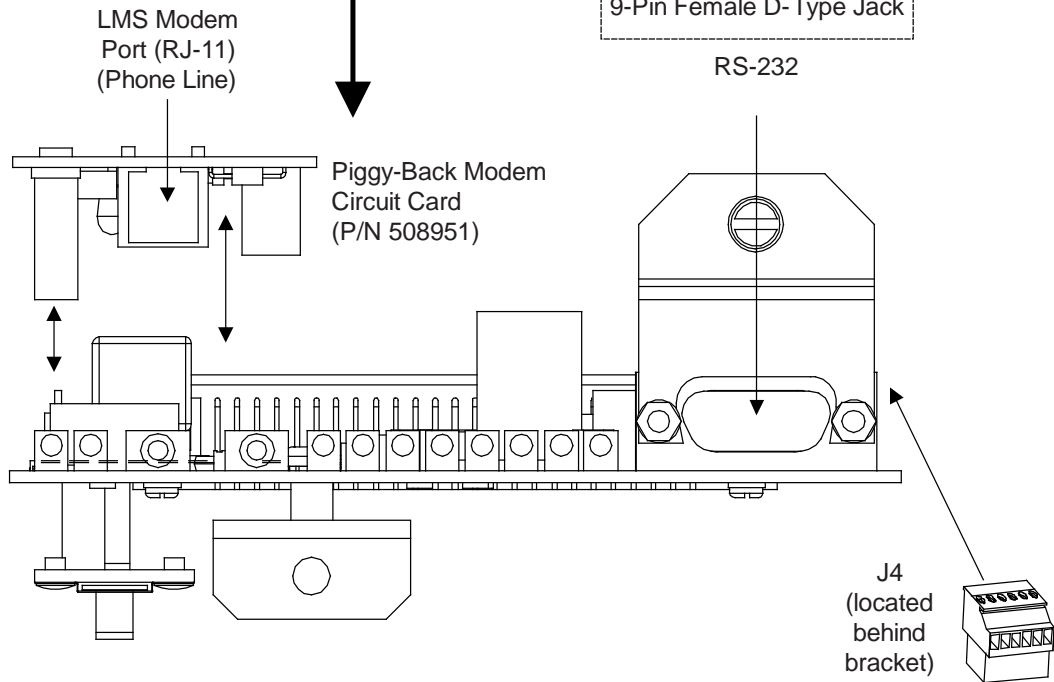
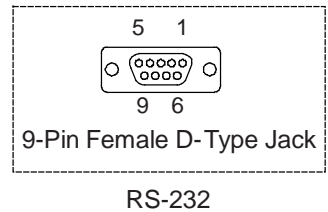

Notes
NC = Normally Closed
C = Common
NO = Normally Open

Relay contacts are shown with the relay de-energized.

Relay contacts are energized during normal operation and de-energized during an alarm condition.

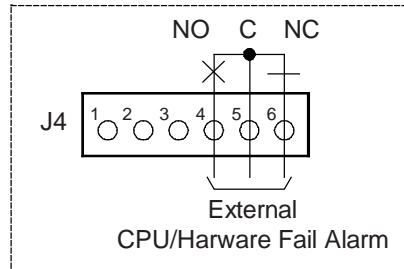
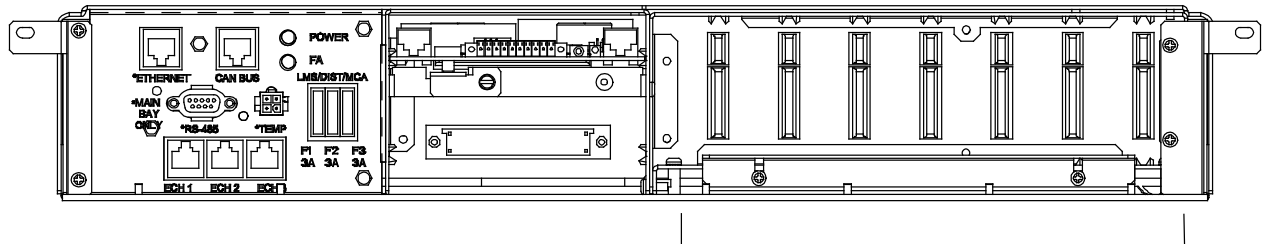

Figure 1.13 Removing Cables – Detail LMS-C

Detail LMS-C



Seven-Slot Card Cage for MCA
Customer Alarm Relay Circuit Cards
and/or LMS Input/Output (I/O) Circuit Cards



Available LMS I/O Circuit Cards

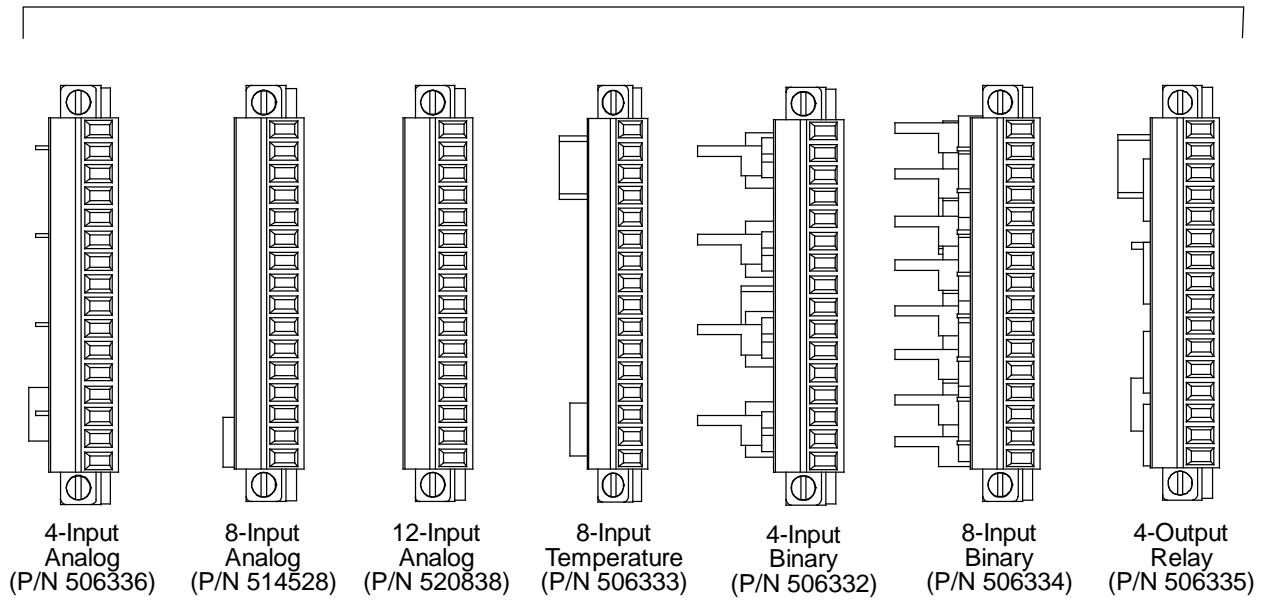

IF THESE LEADS WILL NOT BE REUSED:
DISCONNECT AND REMOVE THESE LEADS FROM THE BAY OR INSULATE
AND TIE BACK THESE LEADS PER YOUR COMPANY POLICIES.

IF THESE LEADS WILL BE RECONNECTED TO THE NCU INTERFACE CARDS:
LABEL THE LEADS THEN TEMPORARILY DISCONNECT, INSULATE, AND TIE
BACK THESE LEADS.

EXISTING LMS TEMPERATURE PROBES ARE NOT COMPATIBLE WITH THE
NCU AND NEW PROBES MUST BE INSTALLED. SEE SAG582140000 FOR
ORDERING DETAILS.

Figure 1.14 Removing System Monitoring and Control Shelf (MCA and LMS)

Power/Distribution Bay Shown,
Power Only Bay Similar

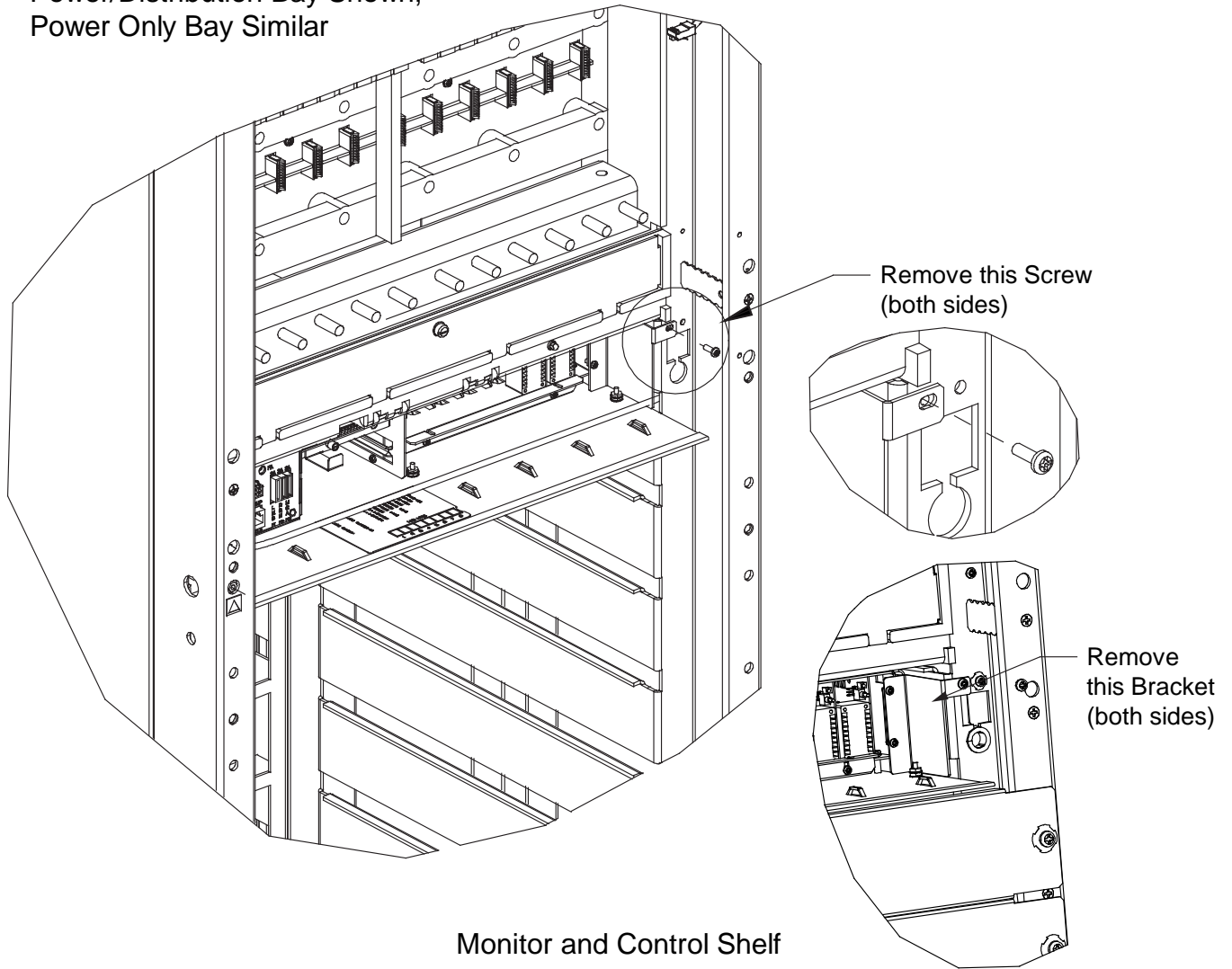

Monitor and Control Shelf

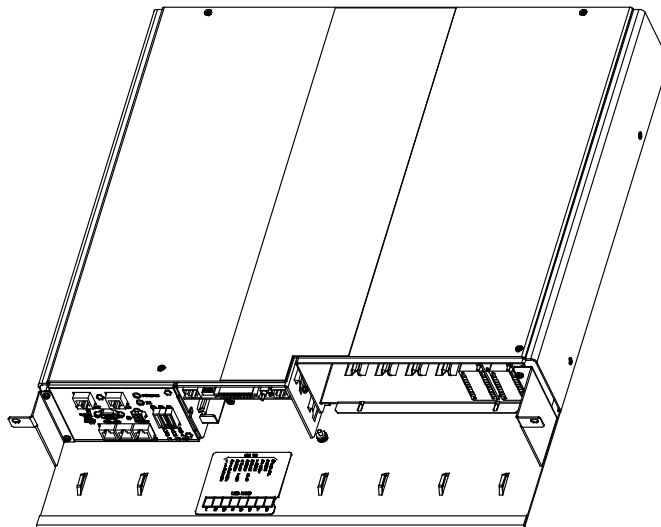

Setting the Bay Address Procedure

- [] 1. Set the bay address. Each bay needs a unique address to communicate with the NCU.
 - a) Dip Switch S1 is used to set the communications address for each bay. Refer to Table 1.3 for S1 settings. Refer to Figure 1.15 for S1 location.
 - b) Set the addressing switches on each kit installed in the system to a unique address per Table 1.3.

Table 1.3 DIP Switch S1 (Bay Addressing)

DIP Switch S1				Description of Status
Communication Address			Reserved	
1	2	3	4	
DOWN	DOWN	DOWN	DOWN	Address 1# (Setting for 1st Bay in System)
UP	DOWN	DOWN		Address 2# (Setting for 2nd Bay in System)
DOWN	UP	DOWN		Address 3# (Setting for 3rd Bay in System)
UP	UP	DOWN		Address 4# (Setting for 4th Bay in System)
DOWN	DOWN	UP		Address 5# (Setting for 5th Bay in System)
UP	DOWN	UP		Address 6# (Setting for 6th Bay in System)
DOWN	UP	UP		Address 7# (Setting for 7th Bay in System)
UP	UP	UP		Address 8# (Setting for 8th Bay in System)

Figure 1.15 DIP Switch S1 (Bay Addressing)

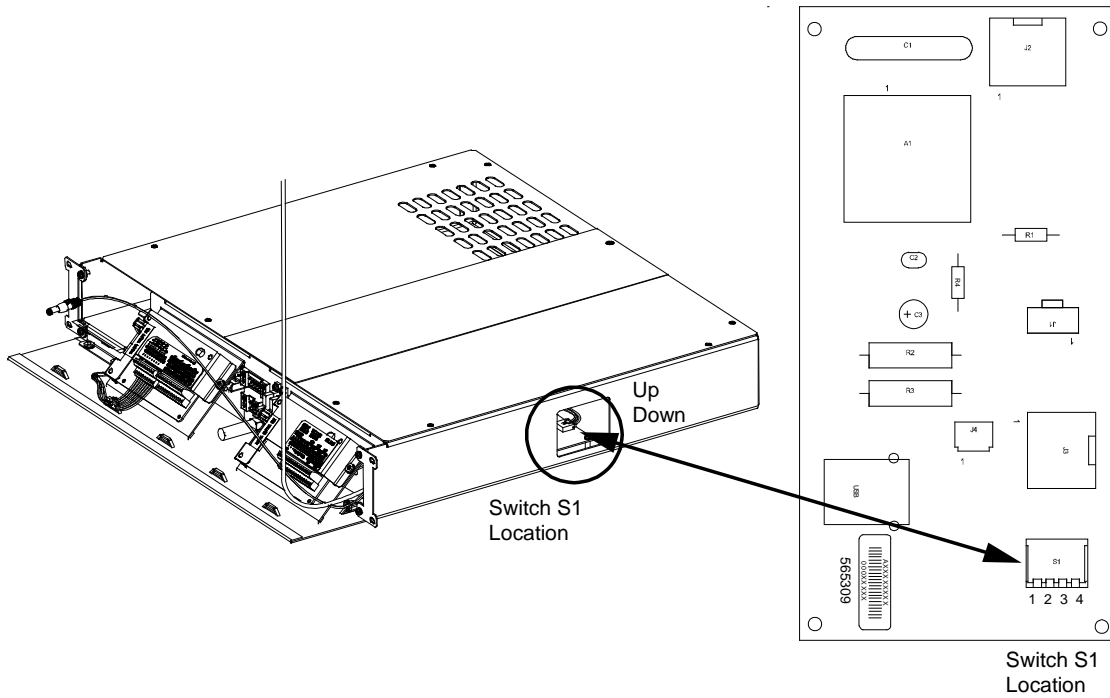

Installing the Kit Furnished Control Shelf Procedure

1. Install the kit furnished control shelf in the same position as the System Monitoring and Control Shelf just removed. See Figure 1.16. Ensure the connector on the back of the control shelf properly mates with the system connector.

Figure 1.16 Installing the Kit Furnished Control Shelf

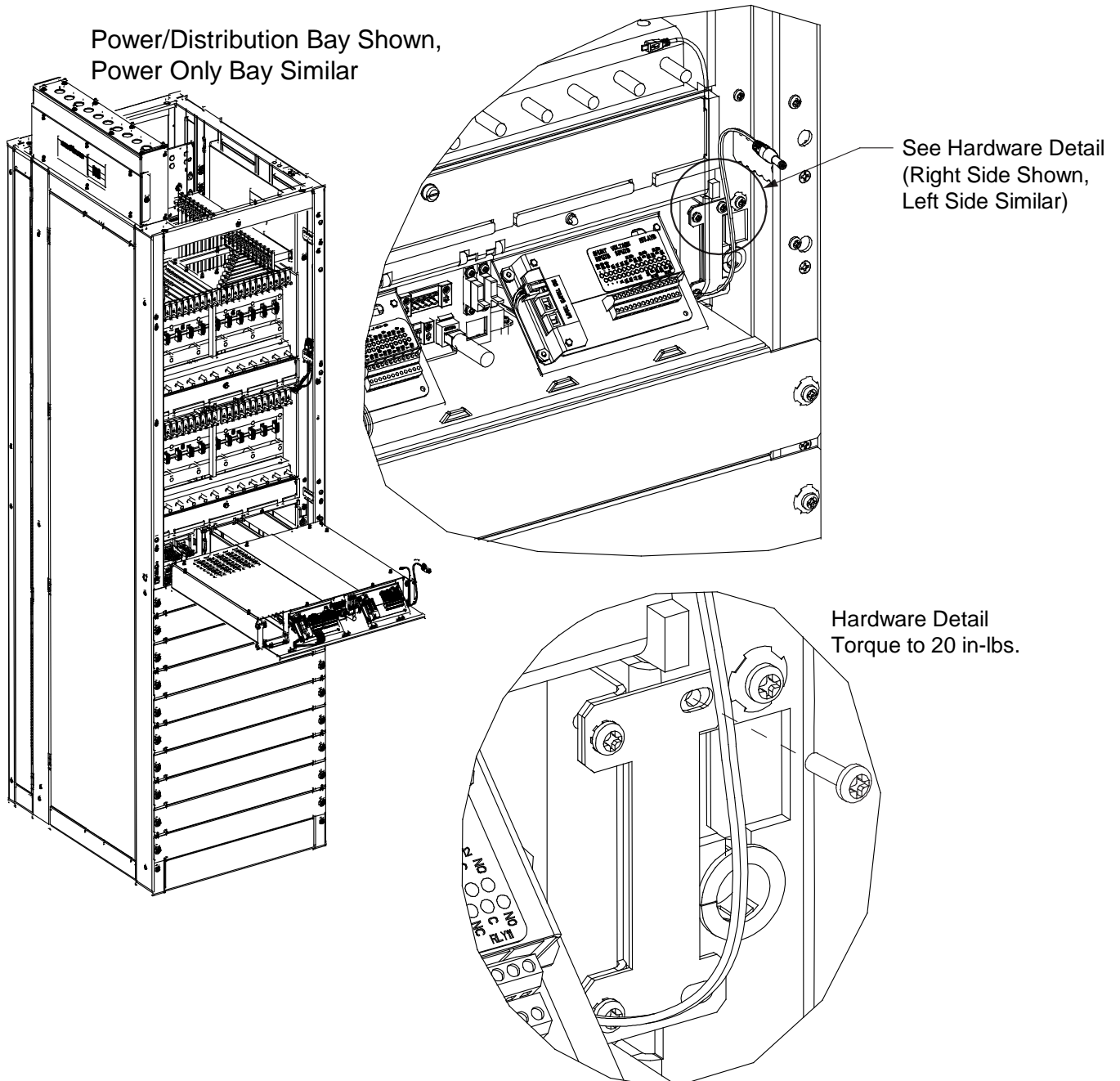

Interconnecting the Kit Furnished Control Shelf to the Kit Furnished Front Door Procedure

- [] 1. Ensure the kit supplied HDMI cable (P/N 152092) is firmly connected between the front door mounted display and the front door mounted interface assembly as shown in Figure 1.17.
- [] 2. Ensure the kit supplied USB cable (P/N 548136) is firmly connected between the front door mounted display and the front door mounted interface assembly as shown in Figure 1.17. You can use any of the four (4) USB ports on the front door mounted interface assembly.
- [] 3. Connect kit supplied RJ-45 Ethernet cable (P/N 149854) factory connected to the RJ-45 connector on the front door mounted interface assembly to the NCU in the control shelf as shown in Figure 1.17.
- [] 4. Connect kit supplied DC cable (P/N 152069) factory connected to the new control shelf to the input power jack on the front door mounted display as shown in Figure 1.17.
- [] 5. Connect kit supplied Micro-USB cable (P/N 152206) factory connected to the new control shelf to the Micro-USB connector on the front door mounted interface assembly as shown in Figure 1.17.

Figure 1.17 Interconnecting the Kit Furnished Control Shelf to the Kit Furnished Front Door

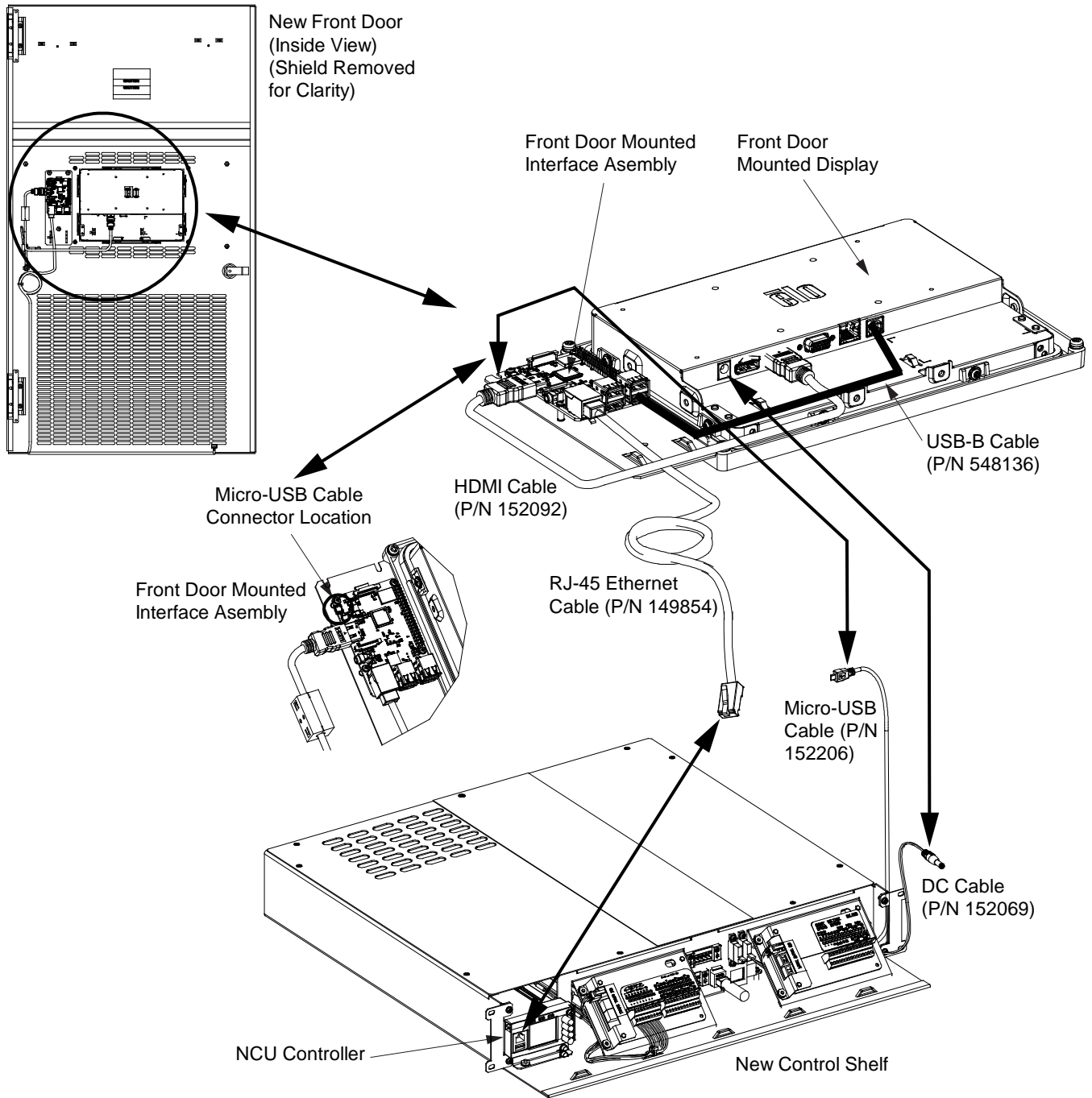

Final Procedure

- [] 1. If power is supplied to the system, the NCU controller goes through an initialization process. After the NCU initializes, ensure that there are no local or remote alarms active on the system.



NOTE! A controller reboot may be required to update controller distribution inventory.

- [] 2. Adhere the kit supplied “distribution designation label” to the inside of the new front door as required.
- [] 3. Refer to the remainder of this manual and make any required external connections to the control shelf, as required. Refer to the NCU controller manual (UM1M830BNA) for programming information.
- [] 4. Connect the Ethernet cable removed from the LMS Ethernet Port to the IB5 Board Ethernet Port located on the control shelf, if required. See Figure 1.19.
- [] 5. Dress and secure the cables connected to the new control shelf to the bay. Ensure the cables cannot be pinched when the door is closed.
- [] 6. Close the front door of the bay.
- [] 7. Ensure that there are no local or remote alarms active on the system.
- [] 8. Enable the external alarms or notify appropriate personnel that this procedure is finished.

Attaching Supplied USB Drive Storage Pouch Near Power System Procedure

The kit is provided with a USB drive that contains the controller configuration files loaded into the controller as shipped. Also provided on the USB drive is a controller configuration drawing and all customer documentation. The USB drive is to be stored in the pouch provided. The pouch needs to be attached to a surface near the system by the customer. See also “Updated Customer Documentation Package” on page 36.

- [] 1. Customer must choose a location near the system to attach the USB drive pouch to.
- [] 2. Make sure the surface is clean, then peel the backing of the pouch fastener and adhere it to the surface.
- [] 3. Attach the pouch to the pouch fastener.
- [] 4. Store the provided USB drive in the USB drive pouch.

1.6 Front Door Assembly Connector Locations

Refer to Figure 1.18 for a connector location illustration.

Figure 1.18 Connector Locations – Front Door

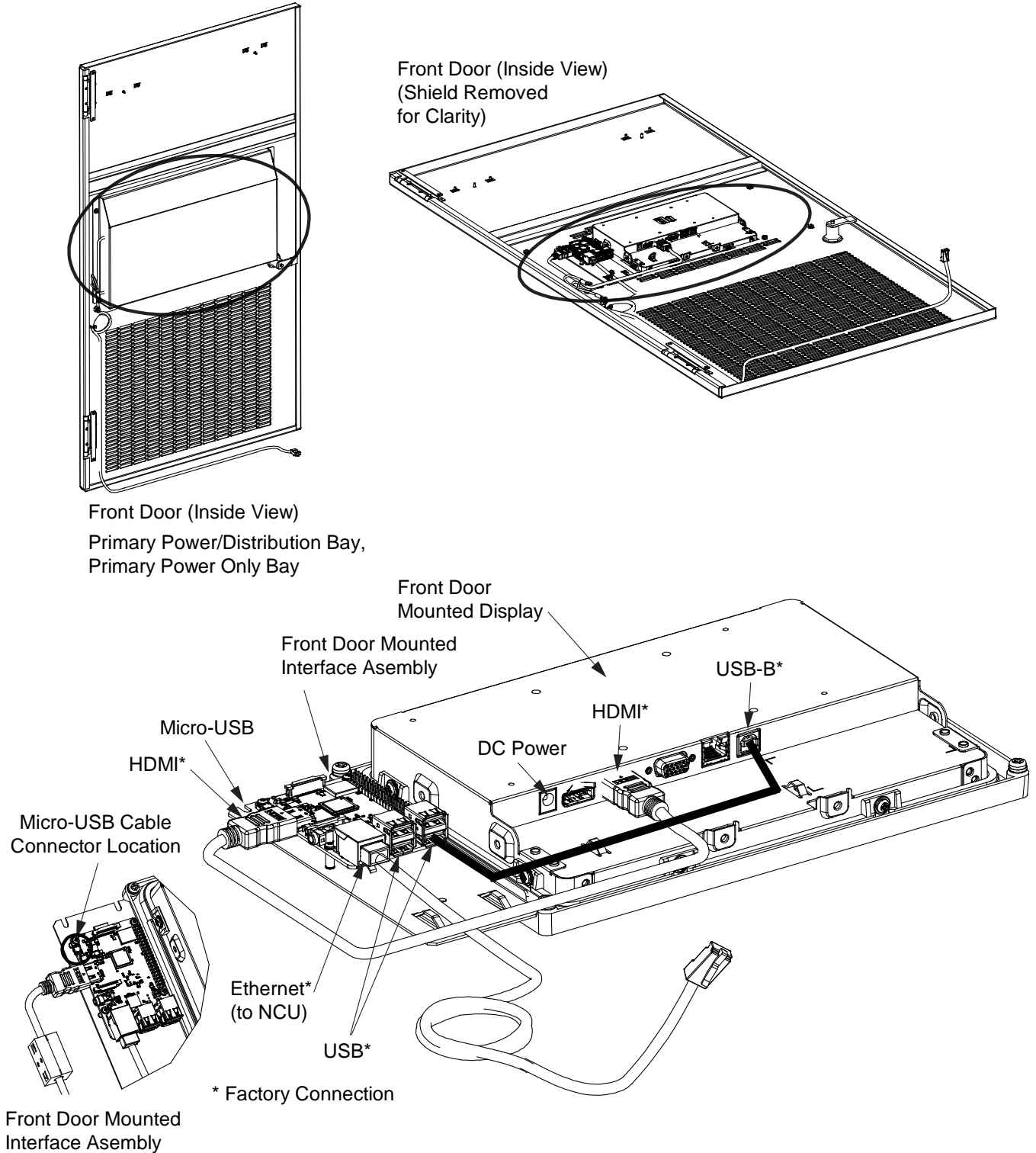

1.7 Control Shelf Connector Locations

Refer to Figure 1.19 for a connector location illustration.

Figure 1.19 Connector Locations – Control Shelf

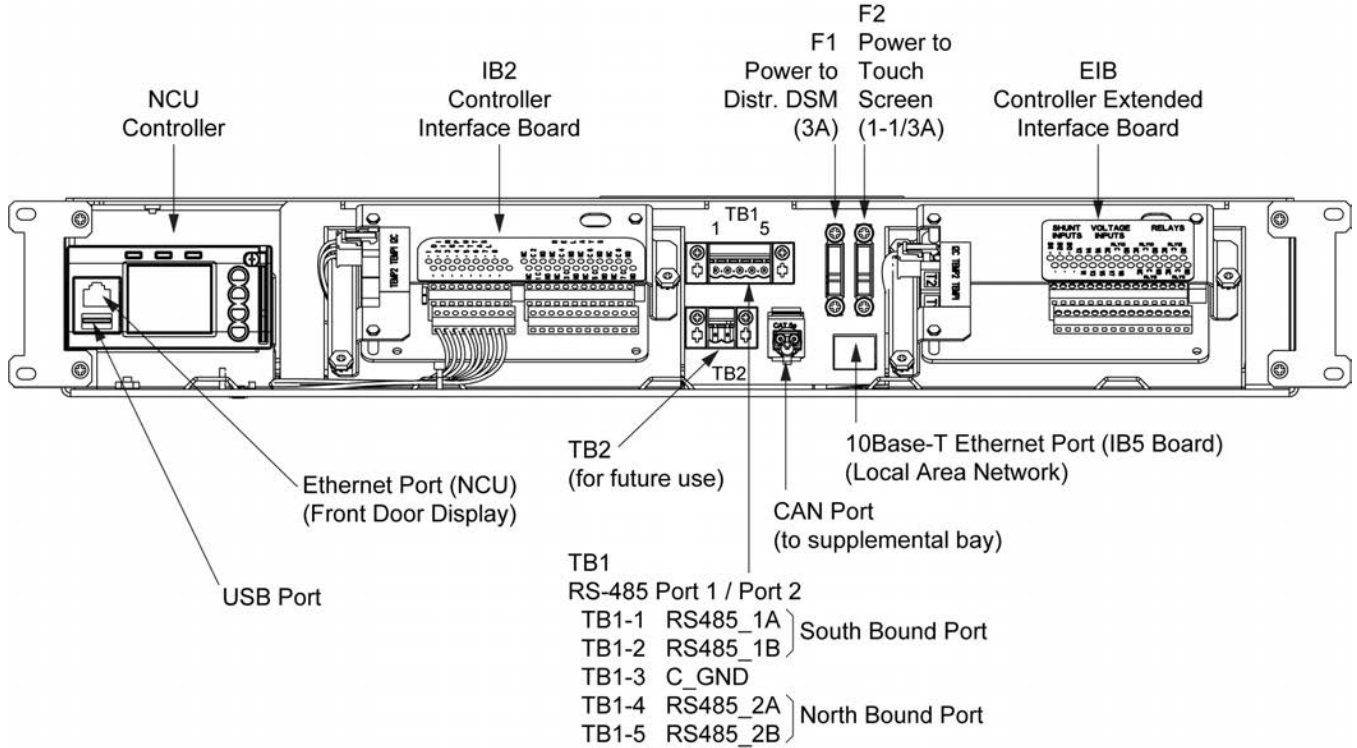

1.8 Local Area Network (LAN) Ethernet Port Connection (IB5 Board)



NOTE! IB5 boards with a 10M/100M/1G Ethernet port replaced IB4 boards with a 10M/100M Ethernet port. This transition enables the support of connected devices that communicate up to 1G. While both boards are physically interchangeable, the IB5 board does require the NCU to have V1.2.80 or higher software loaded.



NOTE! DO NOT connect your Local Area Network (LAN) to the NCU front panel Ethernet port.

Refer to Figure 1.19 for Ethernet Port connector location.

Default Ethernet Port Parameters (IB5 Board)

IPv4

IP Address: 192.168.1.2
Subnet Mask: 255.255.255.0
Default Gateway: 192.168.1.1

IPv6

IPv6 Address: 20fa:fffd:fffc:fffb:fffa:fff9:fff8:fff7
IPv6 Prefix: 0
IPv6 Gateway: 20fa:1:ffff:ffff:fffd:ffff:ffff:ffff

Procedure

1. An RJ-45 10BaseT jack is provided on the IB5 board for connection into a customer's network. This jack has a standard Ethernet pin configuration scheme, twisted pair. Refer to Figure 1.19 for location and Table 1.4 for pin outs. Use shielded Ethernet cable (grounded at both ends). Note that the IB5 board's RJ-45 jack is connected to chassis ground. Refer to the NCU controller instructions (UM1M830BNA) for operational details.



WARNING! The intra-building port(s) of the equipment or subassembly is suitable for connection to intra-building or unexposed wiring or cabling only. The intra-building port(s) of the equipment or subassembly MUST NOT be metallically connected to the interfaces that connect to the OSP or its wiring. These interfaces are designed for use as intra-building interfaces only (Type 2 or Type 4 ports as described in GR-1089-CORE, Issue 4) and require isolation from the exposed OSP cabling. The addition of Primary Protectors is not sufficient protection in order to connect these interfaces metallically to OSP wiring.

The intra-building port (RJ-45) of the equipment or subassembly must use shielded intra-building cabling/wiring that is grounded at both ends.

Table 1.4 RJ-45 Ethernet Port Pin Configuration

Port Pin Number	Name	Definition
1	Tx+	Write Signal +
2	Tx-	Write Signal -
3	Rx+	Read Signal +
4	--	no connection
5	--	no connection
6	Rx-	Read Signal -
7	--	no connection
8	--	no connection

1.9 External Alarm, Reference, and Control Connections

1.9.1 IB2 (Controller Interface Board) Connections (if required)

The IB2 (Controller Interface Board) provides connection points for digital inputs, programmable relay outputs, and temperature probes. The IB2 board is mounted on the control shelf. Refer to Figure 1.19 for location.

Digital Inputs and Programmable Relay Outputs

Digital input and relay output leads are connected to screw-type terminal blocks located on the IB2 board. Recommended torque for these connections is 2.2 in-lbs. Refer to Figure 1.20 for terminal locations. Refer to Table 1.5 and Table 1.6 for pin-out information.

Digital Inputs

Connect up to eight (8) digital inputs to the IB2 board. Note that you must supply both paths for the digital input (either a positive or negative signal and the opposite polarity return path). Observe proper polarity. Refer to Figure 1.20 for terminal locations and Table 1.5 for pin-out information.

The digital inputs can be programmed to provide an alarm when the signal is applied (HIGH) or removed (LOW). Refer to the NCU instructions (UM1M830BNA) for programming information.

Digital Input Ratings: Refer to the following.

- a) Maximum Voltage Rating: 60 VDC.
- b) Active High: > 19 VDC.
- c) Active Low: < 1 VDC.

The digital inputs may be preprogrammed for specific functions. Refer to the configuration drawing (C-drawing) supplied with your system for your system's specific configuration.

Programmable Relay Outputs

The IB2 board provides eight (8) programmable alarm relays with dry Form-C contacts. Connect up to eight (8) relay outputs to the IB2 board. Refer to Figure 1.20 for terminal locations and Table 1.6 for pin-out information.

Refer to the NCU instructions (UM1M830BNA) for programming information.

Relay Ratings: Refer to the following.

- a) Steady State: 0.5 A @ 60 VDC; 1 A @ 30 VDC.
- b) Peak: 3 A @ 30 VDC.

The relays may be preprogrammed for specific functions. Refer to the configuration drawing (C-drawing) supplied with your system for your system's specific configuration.

Temperature Probes



NOTE! Existing LMS temperature probes are not compatible with the NCU and new probes must be installed. See SAG5821400 for ordering details.



NOTE! Each temperature probe consists of two or three pieces that plug together to make a complete probe.

Temperature probes can be connected to the IB2 (Controller Interface Board) and/or EIB (Controller Extended Interface Board) mounted on the control shelf.

Up to two (2) temperature probes can be connected to the IB2 board. Up to two (2) temperature probes can be connected to the EIB board. Any combination of the four (4) temperature probes can be programmed to monitor ambient temperature and/or battery temperature. A temperature probe set to monitor battery temperature can also be used for the rectifier battery charge temperature compensation feature, or the battery charge temperature compensation feature can be programmed to use the average or highest value of all battery temperature probes. The battery charge temperature compensation feature allows the controller to automatically increase or decrease the output voltage of the system to maintain battery float current as battery temperature decreases or increases, respectively. Battery life can be extended when an optimum charge voltage to the battery with respect to temperature is maintained. A temperature probe set to monitor battery temperature can also be used for the BTRM (Battery Thermal Runaway Management) feature. The BTRM feature lowers output voltage when a high temperature condition exists to control against battery thermal runaway.

The temperature sensor end of the probe contains a tab with a 5/16" clearance hole for mounting.

A temperature probe programmed to monitor battery temperature should be mounted on the negative post of a battery cell to sense battery temperature. A temperature probe used for battery charge temperature compensation and/or BTRM (Battery Thermal Runaway Management) should also be mounted on the negative post of a battery cell. A temperature probe programmed to monitor ambient temperature should be mounted in a convenient location, away from direct sources of heat or cold.

Figure 1.20 IB2 (Controller Interface Board) (cont'd on next page)

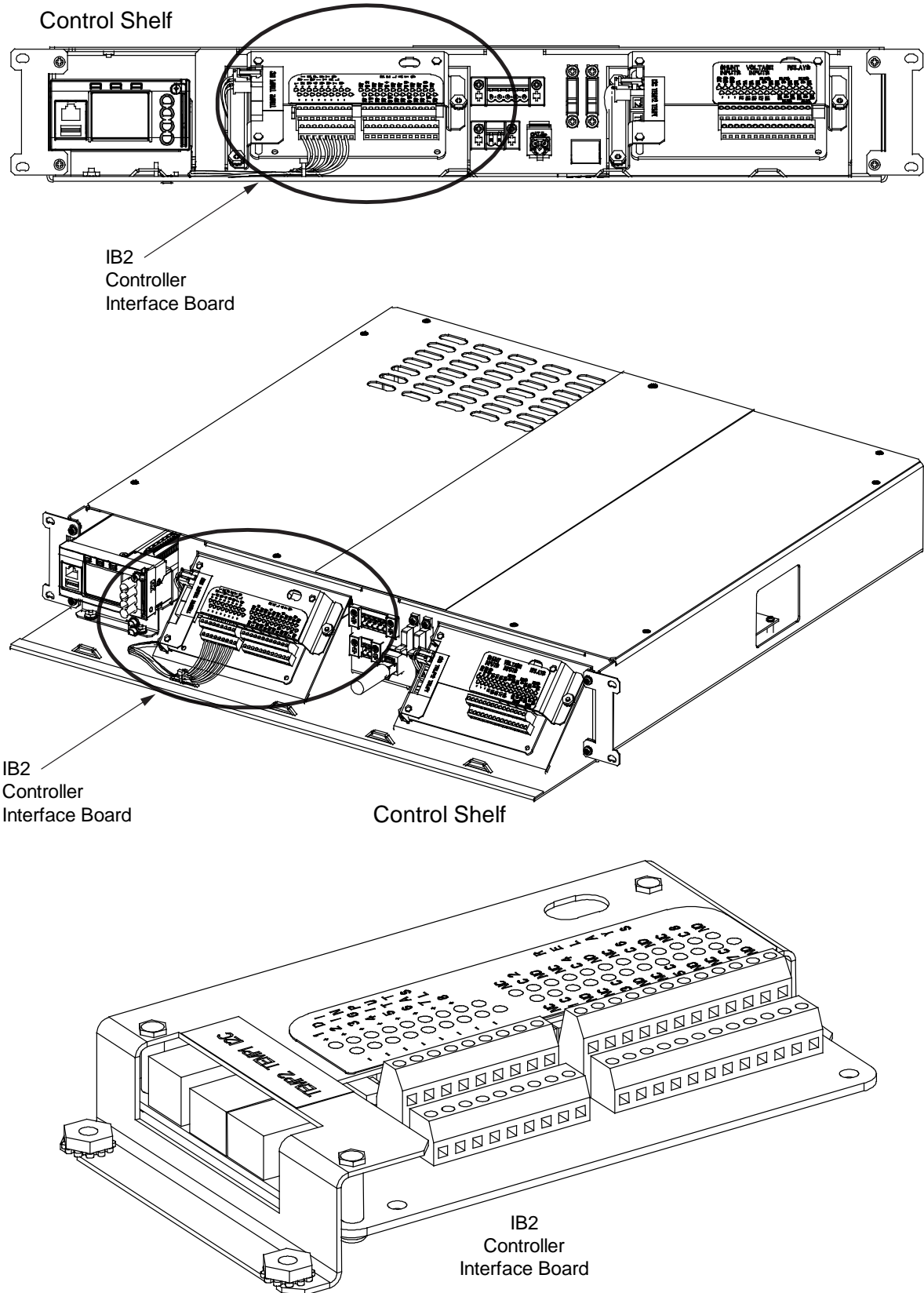
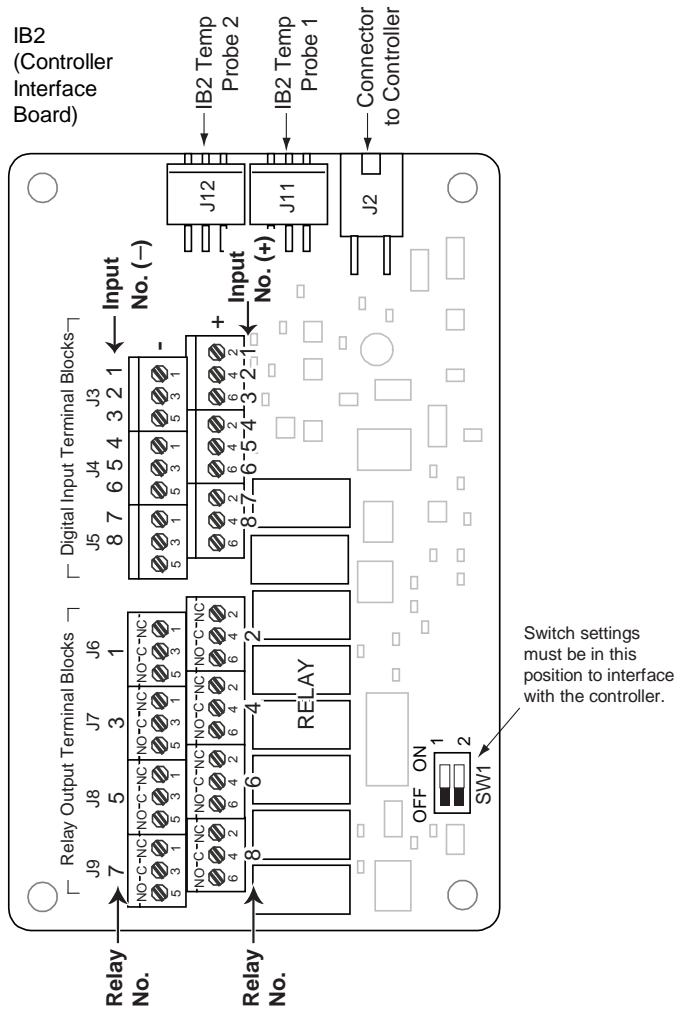
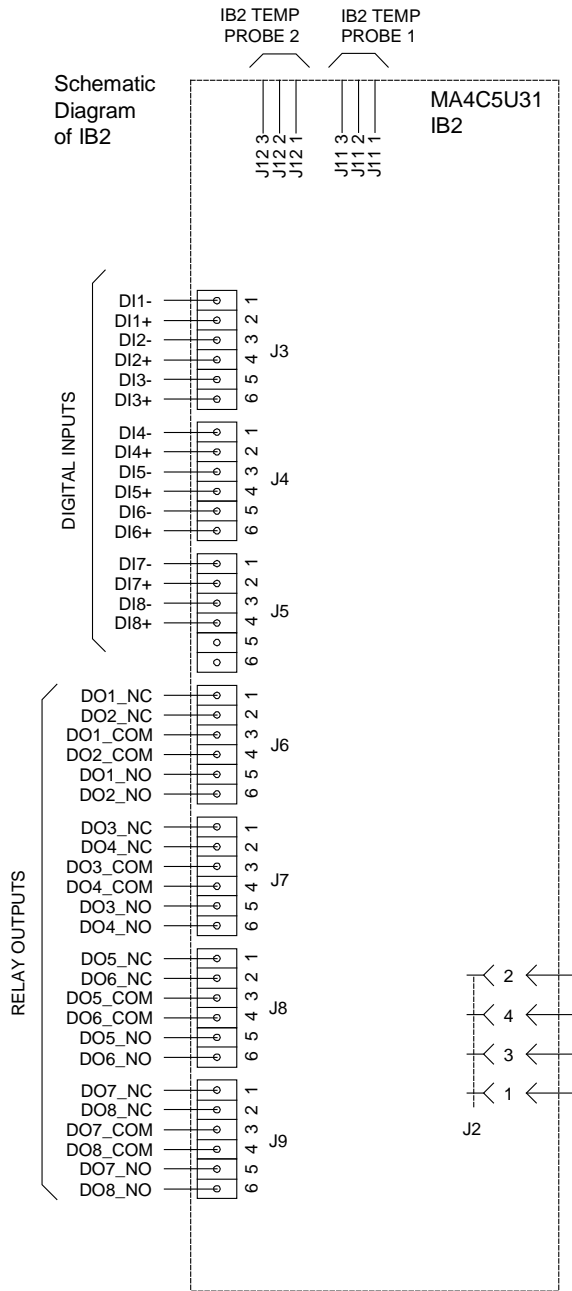
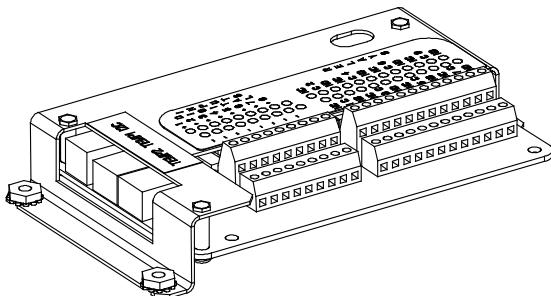

Figure 1.20 IB2 (Controller Interface Board) (cont'd from previous page)



IB2 Assembly



The controller relay assigned to "Major Summary" alarm (relay 1 by default) will operate in the "Fail Safe Mode". "Fail Safe Mode" means Relay 1 is de-energized during an alarm condition, opening the contacts between the C and NO terminals, and closing the contacts between the C and NC terminals.

The controller's remaining seven (7) relays energize during an alarm condition, closing the contacts between the C and NO terminals, and opening the contacts between the C and NC terminals.

Not all I/O points may be available for customer connection (some may be used for factory system connections). Refer to the configuration drawing (C-drawing) supplied with your system for your system's specific configuration.

J3-J9:

- Wire Size Capacity: 16 AWG to 26 AWG.
- Wire Strip Length: 0.20 inch.
- Recommended Torque: 2.2 in-lbs.

Table 1.5 Programmable Digital Inputs (Factory Default) – IB2

Programmable Digital Input	IB2 Pin No.		Factory Wiring	Default Digital Input Function
IB2-1 DI1	J3-1	-	The digital inputs may be preprogrammed for specific functions and have factory wiring connected. Refer to the configuration drawing (C-drawing) supplied with your system for your system's specific configuration.	The digital inputs may be preprogrammed for specific functions. Refer to the configuration drawing (C-drawing) supplied with your system for your system's specific configuration.
	J3-2	+		
IB2-1 DI2	J3-3	-		
	J3-4	+		
IB2-1 DI3	J3-5	-		
	J3-6	+		
IB2-1 DI4	J4-1	-		
	J4-2	+		
IB2-1 DI5	J4-3	-		
	J4-4	+		
IB2-1 DI6	J4-5	-		
	J4-6	+		
IB2-1 DI7	J5-1	-		
	J5-2	+		
IB2-1 DI8	J5-3	-	(to customer ESTOP switch)	ESTOP
	J5-4	+	-48 VDC	
--	J5-5		not used	not used
--	J5-6			



NOTE! -48V is factory wired to the Digital Input #8 (-) terminal for your convenience and function predefined for ESTOP. Customer-furnished system ground applied to terminal Digital Input #8 (+) activates the ESTOP function. The ESTOP function shuts down and locks out the rectifiers. To restart the rectifiers, remove the ESTOP signal and turn AC power to the rectifiers OFF, wait 30 seconds or more (until the LEDs on the rectifier extinguish), then turn AC power to the rectifiers ON.

If a customer-furnished method to disconnect the input power to the system is not provided, the rectifiers will stay locked OFF until the input power is recycled. If the ESTOP signal is removed without recycling the input power, the rectifiers will remain off. The ESTOP alarm from the controller will extinguish. The controller will not issue an alarm for this condition.



NOTE! The digital inputs may be preprogrammed for specific functions. Refer to the configuration drawing (C-drawing) supplied with your system for your system's specific configuration.

Table 1.6 Relay Outputs (Factory Default) – IB2

Programmable Relay Output		IB2 Pin No.	Alarms Assigned to this Relay (Default)
IB2-1 DO1	NC	J6-1	Major Summary
	COM	J6-3	
	NO	J6-5	
IB2-1 DO2	NC	J6-2	Minor Summary
	COM	J6-4	
	NO	J6-6	
IB2-1 DO3	NC	J7-1	Mains Failure
	COM	J7-3	
	NO	J7-5	
IB2-1 DO4	NC	J7-2	Fuse Alarm
	COM	J7-4	
	NO	J7-6	
IB2-1 DO5	NC	J8-1	Under Voltage 1
	COM	J8-3	
	NO	J8-5	
IB2-1 DO6	NC	J8-2	Over Voltage 1
	COM	J8-4	
	NO	J8-6	
IB2-1 DO7	NC	J9-1	Under Voltage 2
	COM	J9-3	
	NO	J9-5	
IB2-1 DO8	NC	J9-2	Over Voltage 2
	COM	J9-4	
	NO	J9-6	



NOTE! The controller relay assigned to “Major Summary” alarm (relay 1 by default) will operate in the “Fail Safe Mode”. “Fail Safe Mode” means Relay 1 is de-energized during an alarm condition, opening the contacts between the C and NO terminals, and closing the contacts between the C and NC terminals. The controller’s seven (7) remaining relays energize during an alarm condition, closing the contacts between the C and NO terminals, and opening the contacts between the C and NC terminals.



NOTE! The relays may be preprogrammed for specific functions. Refer to the configuration drawing (C-drawing) supplied with your system for your system’s specific configuration.

1.9.2 EIB (Controller Extended Interface Board) Connections (if required)

The EIB (Controller Extended Interface Board) provides additional connection points for voltage and current inputs, programmable relay outputs, and temperature probes. The EIB board is mounted on the control shelf. Refer to Figure 1.19 for location.

Current Inputs, Voltage Inputs, and Programmable Relay Outputs

Current input, voltage input, and relay output leads are connected to screw-type terminal blocks located on the EIB board. Recommended torque for these connections is 2.2 in-lbs. Refer to Figure 1.21 for terminal locations. Refer to Table 1.7, Table 1.8, and Table 1.9 for pin-out information.

Current Inputs

Connect up to three (3) shunt inputs to the EIB board. Observe proper polarity. Refer to Figure 1.21 for terminal locations and Table 1.7 for pin-out information.

Refer to the NCU instructions (UM1M830BNA) and program the shunt input parameters found in the EIB menu.



NOTE! The shunt needs to be installed in the hot (-48V) bus. Connect the plus side of the shunt to the positive shunt input on the EIB board. Connect the negative side of the shunt to the negative shunt input on the EIB board.

Voltage Inputs for Battery Block and Battery Midpoint Monitoring

The NCU can monitor battery blocks (12V blocks) or midpoint battery voltage of battery strings connected to the EIB board. The EIB board provides a total of eight (8) DC voltage inputs for these connections. An alarm is issued when either battery block voltage or battery midpoint voltage is abnormal. Refer to Figure 1.21 for terminal locations and Table 1.8 for pin-out information.

Refer to Figure 1.22 for connection details. Refer to the NCU instructions (UM1M830BNA) and program the following parameters found in the EIB menu.



NOTE! When using Battery Block Monitoring, you must make connections to all blocks.

Midpoint Monitoring

Voltage Type: Set to “Midpoint”. This selects the EIB board to monitor the midpoint voltage of up to eight (8) battery strings.

BlockVDiff (Mid): This menu item appears if “Midpoint” is selected above. Set to the alarm threshold for battery midpoint monitoring per site requirements. The NCU issues an alarm when any battery midpoint voltage of any battery string has an abnormal value. The alarm is issued when the difference between any battery midpoint voltage and a reference voltage is greater than the value of the block voltage difference setting.

Block In-Use: Set to number of 12V battery blocks being used.

Battery Block Monitoring

Voltage Type: Set to “48 (Block 4)”. This selects the EIB board to monitor up to two (2) 48V battery strings with four (4) 12V blocks per string.

BlockVDiff (12V): This menu item appears if “48 (Block 4)” is selected above. Set to the alarm threshold for battery block monitoring per site requirements. The NCU issues an alarm when any block voltage of any battery string has an abnormal value. The alarm is issued when the difference between any block voltage and a reference voltage is greater than the value of the block voltage difference setting.

Block In-Use: Set to the number of 12V battery blocks being used.

Programmable Relay Outputs

The EIB board provides five (5) programmable alarm relays with dry Form-C contacts. Connect up to five (5) relay outputs to the EIB board. Refer to Figure 1.21 for terminal locations and Table 1.9 for pin-out information.

Refer to the NCU instructions (UM1M830BNA) for programming information.

Relay Ratings: Refer to the following.

- a) Steady State: 0.5 A @ 60 VDC; 1 A @ 30 VDC.
- b) Peak: 3 A @ 30 VDC.

The relays may be preprogrammed for specific functions. Refer to the configuration drawing (C-drawing) supplied with your system for your system's specific configuration.

Temperature Probes

Temperature probes can be connected to the EIB board. Refer to "Temperature Probes" on page 26.

Figure 1.21 EIB (Controller Extended Interface Board) (cont'd on next page)

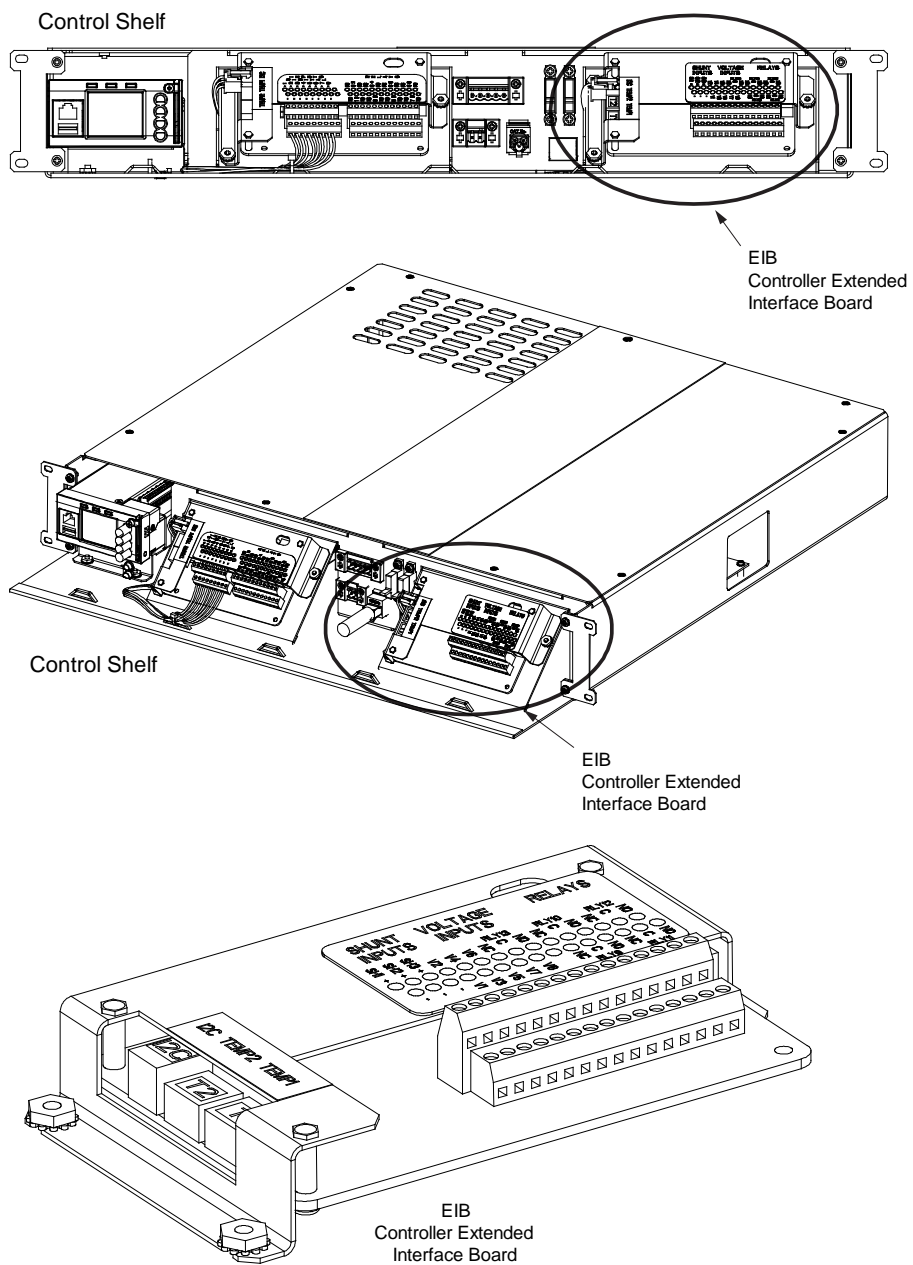

Figure 1.21 EIB (Controller Extended Interface Board) (cont'd from previous page)

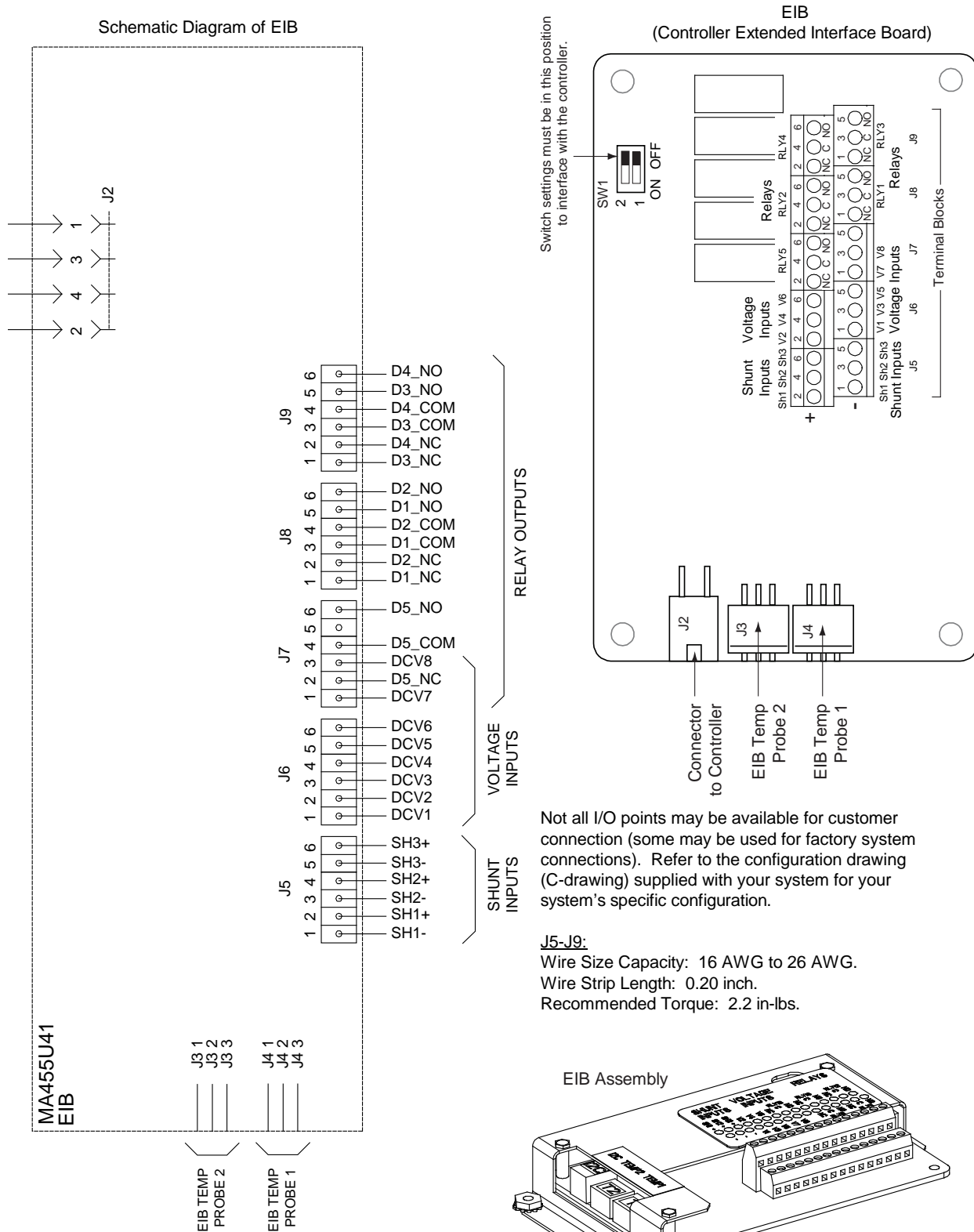

Table 1.7 Shunt Inputs – EIB

Shunt Input	EIB Pin No.		Factory Wiring	Default Function
Sh1	J5-1	-	--	none
	J5-2	+	--	
Sh2	J5-3	-	--	none
	J5-4	+	--	
Sh3	J5-5	-	--	none
	J5-6	+	--	

Table 1.8 Voltage Inputs – EIB

Voltage Input	EIB Pin No.	Default Function
1	J6-1	Battery Block Monitoring
2	J6-2	
3	J6-3	
4	J6-4	
5	J6-5	
6	J6-6	
7	J7-1	
8	J7-3	

Table 1.9 Relay Outputs (Factory Default) – EIB

Programmable Relay Output	EIB Pin No.		Alarms Assigned to this Relay (Default)
EIB-1 DO1	NC	J8-1	Not Used
	COM	J8-3	
	NO	J8-5	
EIB-1 DO2	NC	J8-2	Test / Equalize
	COM	J8-4	
	NO	J8-6	
EIB-1 DO3	NC	J9-1	Rectifier Alarms
	COM	J9-3	
	NO	J9-5	
EIB-1 DO4	NC	J9-2	Multi-Rectifier Fail
	COM	J9-4	
	NO	J9-6	
EIB-1 DO5	NC	J7-2	OB Summary
	COM	J7-4	
	NO	J7-6	

NOTE! The relays energize during an alarm condition, closing the contacts between the C and NO terminals, and opening the contacts between the C and NC terminals.

NOTE! The relays may be preprogrammed for specific functions. Refer to the configuration drawing (C-drawing) supplied with your system for your system's specific configuration.

Figure 1.22 Sample Battery Midpoint Monitoring or Battery Block Monitoring Connections

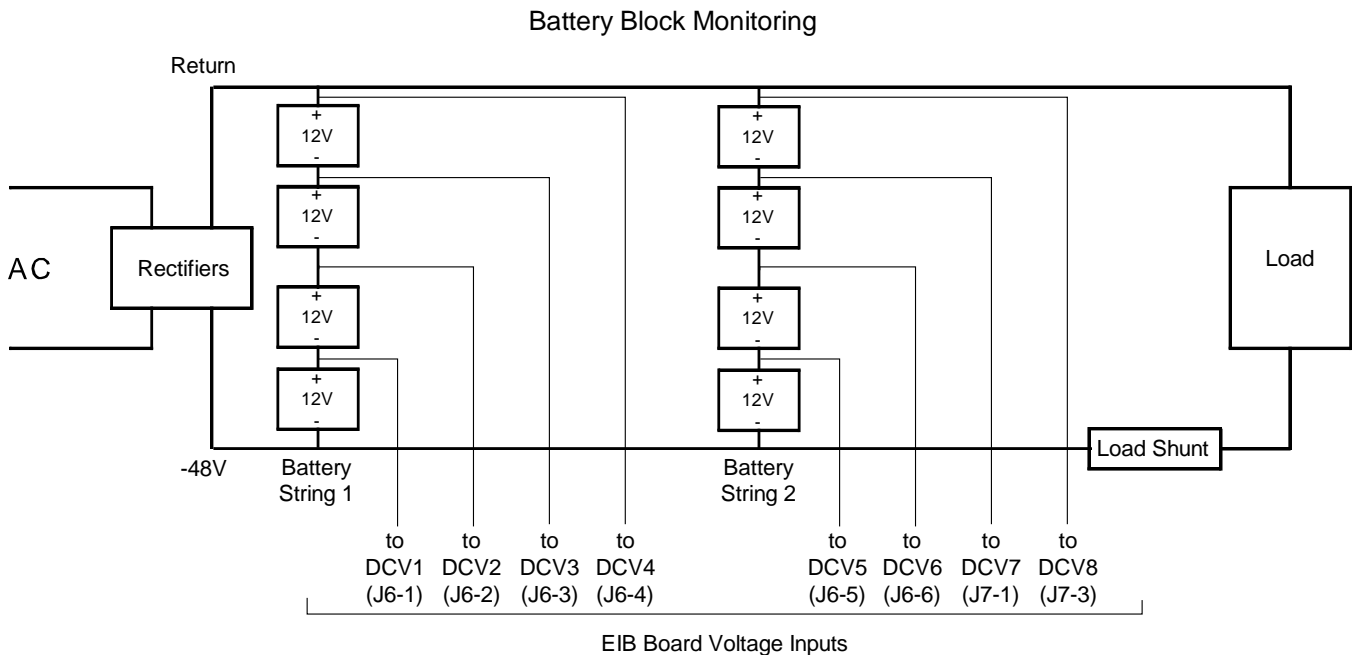
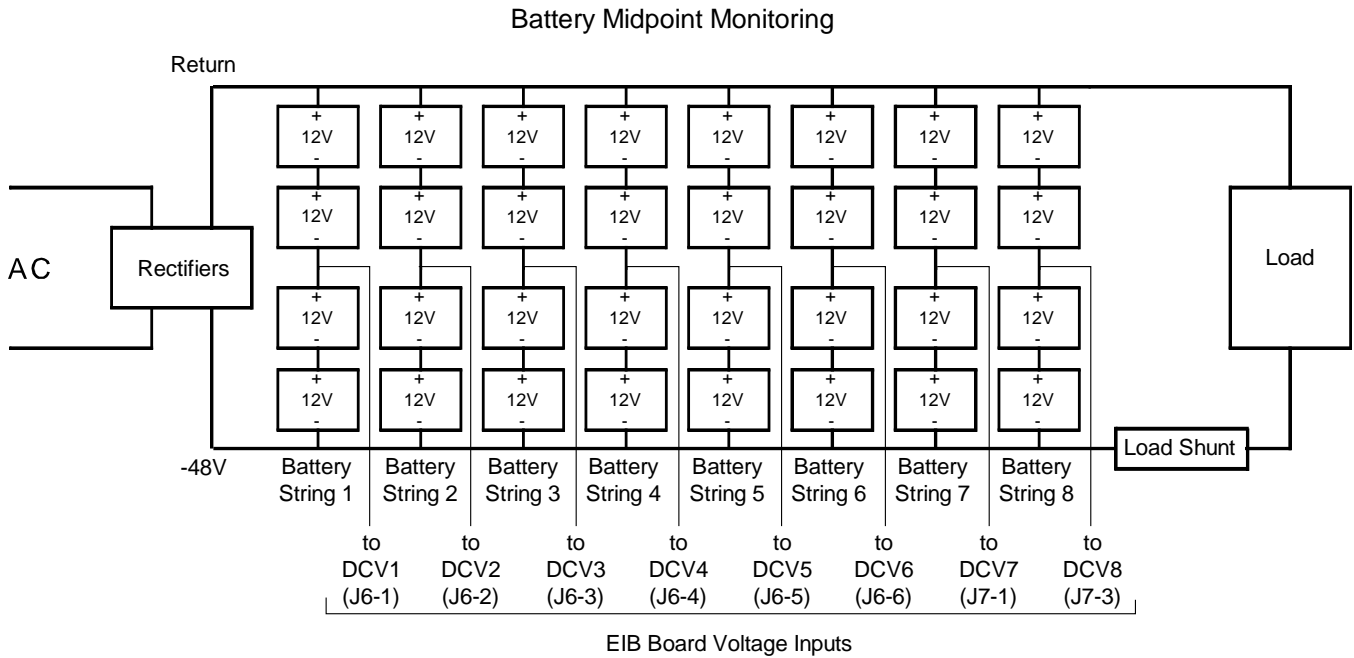

2 Updated Customer Documentation Package

Refer to the documents located on the USB drive furnished with the kit for updated customer documentation. This replaces the documentation originally supplied with your system.

The complete new Customer Documentation Package consists of...

USB Drive with All Customer Documentation

Vertiv™ NetSure™ 8200 Series

- Power System Installation Instructions: IM582140000
- Power System User Instructions: UM582140000
- NCU Controller User Instructions: UM1M830BNA
- Power System “System Application Guide”: SAG582140000
- Contact Information Page: Section 4154
- Engineering Drawings
 - SD582140000
 - T582140000
- Also provided on the USB drive is a controller configuration drawing and the controller configuration files loaded into the controller as shipped.

Connect with Vertiv on Social Media



<https://www.facebook.com/vertiv/>



<https://www.instagram.com/vertiv/>



<https://www.linkedin.com/company/vertiv/>



<https://www.x.com/vertiv/>



Vertiv.com | Vertiv Headquarters, 505 N Cleveland Ave, Westerville, OH 43082, USA

© 2026 Vertiv Group Corp. All rights reserved. Vertiv™ and the Vertiv logo are trademarks or registered trademarks of Vertiv Group Corp. All other names and logos referred to are trade names, trademarks or registered trademarks of their respective owners. While every precaution has been taken to ensure accuracy and completeness here, Vertiv Group Corp. assumes no responsibility, and disclaims all liability, for damages resulting from use of this information or for any errors or omissions.