



NetSure™ 8200 Series -48 VDC Power System

Installation Manual

Specification Number: 582140000

Model Number: 8200NLDB, 8200NLEB, 8200NL-B

The information contained in this document is subject to change without notice and may not be suitable for all applications. While every precaution has been taken to ensure the accuracy and completeness of this document, Vertiv assumes no responsibility and disclaims all liability for damages resulting from use of this information or for any errors or omissions. Refer to other local practices or building codes as applicable for the correct methods, tools, and materials to be used in performing procedures not specifically described in this document.

The products covered by this instruction manual are manufactured and/or sold by Vertiv. This document is the property of Vertiv and contains confidential and proprietary information owned by Vertiv. Any copying, use or disclosure of it without the written permission of Vertiv is strictly prohibited.

Names of companies and products are trademarks or registered trademarks of the respective companies. Any questions regarding usage of trademark names should be directed to the original manufacturer.

Technical Support Site

If you encounter any installation or operational issues with your product, check the pertinent section of this manual to see if the issue can be resolved by following outlined procedures.

Visit <https://www.vertiv.com/en-us/support/> for additional assistance.

TABLE OF CONTENTS

Admonishments Used in this Document.....	vi
Important Safety Instructions.....	vii
Safety Admonishments Definitions.....	vii
Safety and Regulatory Statements.....	vii
Déclarations de Sécurité et de Réglementation.....	vii
1 Customer Documentation Package.....	1
2 Installation Acceptance Checklist.....	1
3 Physical Security.....	3
4 Placing the Bays and Installing Internal/External Busbars.....	3
4.1 General Requirements.....	3
4.2 Placing and Securing List 101 and List 111 Power/Distribution Bays (without PDSC).....	4
4.3 Placing and Securing List 102 and List 112 Power/Distribution Bays (with PDSC).....	5
4.4 Placing and Securing List 103, 104, 105, 113, 114, and 115 Power Only Bays.....	7
4.5 Placing and Securing List 116, 117, 118, and 122 Distribution Only Bays.....	8
4.6 Installing Power/Distribution Bay to Power/Distribution Bay Negative and Positive Busbar Links.....	27
4.7 Installing Power/Distribution Bay to Power/Distribution Bay Negative and Positive Busbar Links (Newer Style Bay to an Existing Older Style Bay).....	30
4.8 Connecting Power/Distribution Bay Rectifier Mounting Position AC Input Connectors to PDSC (Lists 102 and 112 Only).....	32
4.9 Installing Power/Distribution Bay External Top-Mount Horizontal Battery Input Busbar Assembly, P/N 554873 (if furnished).....	33
4.10 Installing Optional Power/Distribution Bay Busbar Shield Kit, P/N 528482 (if furnished).....	42
4.11 Installing Power/Distribution Bay External Top-Mount Ground (Load Return) Busbar Assembly; P/N 514688, 514689, 514690, or 514691 (if furnished).....	43
4.12 Installing Power/Distribution Bay Load Return Lug Extension Busbar Assembly, P/N 514543 (if furnished).....	59
4.13 Installing Power/Distribution Bay External Top-Mount Vertical Battery Input Busbar Assembly, P/N 554874 (if furnished).....	68
4.14 Installing Distribution Only Bay External Top-Mount Ground (Load Return) Busbar Assembly; P/N 528775 (if furnished).....	77
4.15 Installing Distribution Only Bay External Top-Mount Ground (Load Return) Extension Busbar Assembly; P/N 528780 (if furnished).....	79
5 Installing Distribution Fuses and Circuit Breakers.....	82
5.1 Installing 218 Circuit Breakers, TPL Fuseholders, and Bullet Nose-Type Device Mounting Assemblies into Power/Distribution Bays.....	82
5.2 Installing 218 Circuit Breakers and TPL Fuseholders into Distribution Only Bays.....	82
5.3 Installing TPL Fuses.....	83
5.4 Installing TLS/TPS Fuses.....	83
5.5 Installing Bullet Nose-Type Circuit Breakers.....	83
5.6 Installing an Optional Bullet Nose-Type 10-Position GMT Fuse Module.....	83
5.7 Storing Spare Fuses.....	84
5.8 Recording Fuse and Circuit Breaker Sizes.....	84
6 Making Switch and Jumper Settings.....	99
6.1 Switch Settings on IB2 and EIB Interface Boards.....	99
6.2 Switch Settings on SM-DUE.....	103

6.3	Jumper Settings on SM-DUE	104
6.4	Jumper Setting on Distribution Bus Monitoring Circuit Cards (for use in systems with an MCA only).....	106
7	Making Electrical Connections	108
7.1	Important Safety Instructions.....	108
7.2	Wiring Considerations.....	108
7.3	Bay-to-Bay Interconnections	108
7.4	Distribution Only Bay BAT RTN Connection to System Monitoring and Control Section.....	112
7.5	External Alarm, Reference, and Control Connections	113
7.5.1	Connector Locations on Inside of Primary Power/Distribution Bay and Primary Power Only Bay Front Door.....	113
7.5.2	Connector Locations on Primary Power/Distribution Bay and Primary Power Only Bay Control Shelf.....	114
7.5.3	Connector Locations on Secondary Power/Distribution Bay and Secondary Power Only Bay Control Shelf.....	115
7.5.4	Local Area Network (LAN) Ethernet Port Connection (IB5 Board).....	116
7.5.5	IB2 (Controller Interface Board) Connections (if required)	118
7.5.6	EIB (Controller Extended Interface Board) Connections (if required)	124
7.5.7	Customer Connections to SM-DUE (if required).....	131
7.5.8	Surge Suppression Alarms (if option installed).....	139
7.6	Bay Frame Grounding Connections.....	140
7.7	Load Connections	142
7.8	AC Input and AC Input Ground Connections.....	151
7.9	Battery Connections	164
7.10	Re-Install Shields and Cover Panels.....	169
8	Installing the Rectifiers.....	170
9	Initially Starting, Configuring, and Checking System Operation.....	171
9.1	Initial Startup Preparation	171
9.2	Initially Starting the System	171
9.3	NCU Controller Initialization	171
9.4	Verifying and Setting the NCU Controller as Required for Your Application.....	174
9.4.1	General.....	174
9.4.2	Using the NCU Local Display and Keypad.....	174
9.4.3	Using the NCU Start Wizard from the NCU Local Display and Keypad.....	174
9.4.4	Using the Primary Power/Distribution Bay or Primary Power Only Bay Front Panel Touch Screen to Access the NCU Webpages	175
9.4.5	Verifying the Configuration File.....	175
9.4.6	Checking Basic System Settings.....	176
9.4.7	Changing Battery Capacity Rating in the NCU	177
9.4.8	Configuring the NCU Identification of Rectifiers and Assigning which Input Feed is Connected to the Rectifiers.....	178
9.5	NCU Alarm Relay Check.....	178
9.6	Checking AC Fail Alarm	178
9.7	Checking Rectifier Alarm.....	179
9.8	Checking System Over Voltage Alarm 1 and Over Voltage Alarm 2.....	180
9.9	Checking System Under Voltage Alarm 1 and Under Voltage Alarm 2.....	181
9.10	Checking Circuit Breaker/Fuse Alarm	182

9.11 Checking System Status	184
9.12 Final Steps	184

Admonishments Used in this Document



DANGER! Warns of a hazard the reader *will* be exposed to that will *likely* result in death or serious injury if not avoided. (ANSI, OSHA)



WARNING! Warns of a potential hazard the reader *may* be exposed to that *could* result in death or serious injury if not avoided. This admonition is not used for situations that pose a risk only to equipment, software, data, or service. (ANSI)



CAUTION! Warns of a potential hazard the reader *may* be exposed to that *could* result in minor or moderate injury if not avoided. (ANSI, OSHA) This admonition is not used for situations that pose a risk only to equipment, data, or service, even if such use appears to be permitted in some of the applicable standards. (OSHA)



ALERT! Alerts the reader to an action that *must be avoided* in order to protect equipment, software, data, or service. (ISO)



ALERT! Alerts the reader to an action that *must be performed* in order to prevent equipment damage, software corruption, data loss, or service interruption. (ISO)



FIRE SAFETY! Informs the reader of fire safety information, reminders, precautions, or policies, or of the locations of fire-fighting and fire-safety equipment. (ISO)



SAFETY! Informs the reader of general safety information, reminders, precautions, or policies not related to a particular source of hazard or to fire safety. (ISO, ANSI, OSHA)

Important Safety Instructions

Safety Admonishments Definitions

Definitions of the safety admonishments used in this document are listed under “Admonishments Used in this Document” on page vi.

Safety and Regulatory Statements

Refer to Section 4154 (provided with your customer documentation) for Safety and Regulatory Statements.

Déclarations de Sécurité et de Réglementation

Reportez-vous à la Section 4154 (fourni avec les documents de votre client) pour les déclarations de sécurité et de réglementation.

This page intentionally left blank.

1 Customer Documentation Package



NOTE! These instructions are for the Vertiv™ NetSure™ 8200 Series -48 VDC Power System, Model 8200NLDB (208V Input Power/Distribution and Power Only Bays), 8200NLEB (480V Input Power/Distribution and Power Only Bays), and 8200NL-B (Distribution Only Bay); Spec. No. 582140000. **This power system is equipped with the NCU controller.**

If you have a Vertiv™ NetSure™ 802 Series -48 VDC Power System, Model 802NLDB (208V Input Power/Distribution and Power Only Bays), 802NLEB (480V Input Power/Distribution and Power Only Bays), and 802NL-B (Distribution Only Bay); Spec. No. 582140000, refer to document “Section 5876” provided with your system. **This power system is equipped with the MCA (Meter, Control, Alarm Panel) and LMS (Lorain Monitoring System).**

This document (IM582140000) provides *Installation Instructions* for the Vertiv™ NetSure™ 8200 Series -48 VDC Power System, Model 8200NLDB (208V Input Power/Distribution and Power Only Bays), 8200NLEB (480V Input Power/Distribution and Power Only Bays), and 8200NL-B (Distribution Only Bay); Spec. No. 582140000.

For factory settings of all configurable parameters, refer to the configuration drawing (C-drawing) supplied with your system.

The complete Customer Documentation Package consists of...

-48 VDC Power System Installation Manual

- Power System Installation Instructions: IM582140000

NCU Controller User Manual

- NCU Controller User Instructions: UM1M830BNA

USB Drive with All Customer Documentation

Vertiv™ NetSure™ 8200 Series

- Power System Installation Instructions: IM582140000
- Power System User Instructions: UM582140000
- NCU Controller User Instructions: UM1M830BNA
- Power System “System Application Guide”: SAG582140000
- Contact Information Page: Section 4154
- Engineering Drawings
 - SD582140000
 - T582140000
- Also provided on the USB drive is a controller configuration drawing and the controller configuration files loaded into the controller as shipped.

Vertiv™ NetSure™ 802 Series

- Power System Installation Instructions: Section 5876
- Power System User Instructions: Section 5877
- Power System Installation Guide: Section 5957
(condensed version of Section 5876 Installation Instructions)

2 Installation Acceptance Checklist

Provided below is an Installation Acceptance Checklist. This checklist helps ensure proper installation and initial operation of the system. As the procedures presented in this document are completed, check the appropriate box on this list. If the procedure is not

required to be performed for your installation site, also check the box in this list to indicate that the procedure was read. When installation is done, ensure that each block in this list has been checked. Some of these procedures may have been factory performed for you.



NOTE! *The system is not powered up until the end of this checklist.*



NOTE! *Some of these procedures may have been performed at the factory for you.*

Placing the Bays and Installing Internal/External Busbars

- Bays (and PDSC if furnished) Bolted Together (if required) and Mounted to Floor
- Bay-to-Bay Busbar Links Installed (if required)
- PDSC (if furnished) AC Input Connectors Connected to Power/Distribution Bay
- External Top-Mount Busbar Assemblies Installed (if furnished)

Installing Distribution Devices

- Distribution Fuses and Circuit Breakers Installed
- Distribution Lug Adapter Plates Installed

Making Switch and Jumper Settings

- Factory Switch Settings on IB2 Board Verified
- Factory Switch Settings on EIB Board Verified
- Jumper and Switch Settings on SM-DUE Board Set
- Jumper Setting on Distribution Bus Monitoring Circuit Cards Set

Making Electrical Connections

- Bay-to-Bay Interconnections Made
- Distribution Only Bay BAT RTN Connection to System Monitoring and Control Section Made
- External Alarm, Reference, Monitoring, and Control Connections Made
- Bay Frame Grounding Connections Made
- Load Connections Made
- AC Input and AC Input Ground Connections Made
- Battery Connections Made
- All Shields and Cover Panels in Re-Installed

Installing the Rectifiers

- Rectifiers Installed

Initially Starting the Power System

- System Started, Configured, and Checked

3 Physical Security

This product is designed and intended to be deployed and operated in a physically secure and network firewall-protected location. Vertiv recommends a review of the physical security and operating environment of the unit. Since an attacker or disgruntled user can cause serious disruption, below are some recommended best practices that include, but are not limited to:

Restrict access to areas, racks, and units with encrypted card RFID/badges, unique multi-factor passcode authentication for access, man traps, and biometric scanners for physical access to the equipment.

Have trusted and background-checked security guards with 24x7x365 physical presence and written logs to help document and note physical access to a data center, building, rack, and so on.

Restrict physical access to telecommunications equipment and network cabling. Physical access to the telecommunications lines and network cabling should be restricted to protect against attempts to intercept or sabotage communications. Best practices include use of metal conduits for the network cabling running between equipment cabinets.

All USB, RJ45, and/or any other physical ports should be restricted on the units.

Do not connect removable media (such as USB devices, SD cards, and so on) for any operation (such as firmware upgrade, configuration change, or boot application change) unless the origin of media is known and trusted. Before connecting any portable device through a USB port or SD card slot, scan the device for malware and viruses.

4 Placing the Bays and Installing Internal/External Busbars

4.1 General Requirements

- The installer should be familiar with the installation requirements and techniques to be used in securing the bay(s) to the floor.
- This product is intended only for installation in a Restricted Access Location on or above a non-combustible surface.
- This product is intended for installation in Network Telecommunication Facilities (CO, vault, hut, or other environmentally controlled electronic equipment enclosure).
- This product is intended to be connected to the common bonding network in a Network Telecommunication Facility (CO, vault, hut, or other environmentally controlled electronic equipment enclosure).
- Front and rear access is required for installation.
- Typical industry standards recommended minimum aisle space clearance is 2' 6" for the front of the bay(s) and 2' for the rear of the bay(s). See also next paragraph.
- Rectifier ventilating openings must not be blocked and temperature of air entering rectifiers must not exceed rated operating ambient temperature range found in System Application Guide SAG582140000. Distance from rear of a power/distribution or power only bay to a wall or other solid structure must not be less than 6 inches. This assures proper airflow through the rectifiers.
- The system consists of from 1 to 8 bays, depending upon your power requirements. All bays that are designed to be bussed together must be placed in a line adjacent to each other, with no space between bays. It is recommended to place the primary power/distribution bay or primary power only bay on the far right or far left end of the bay line-up, and to expand the system to the left or right of the primary power/distribution bay or primary power only bay. This allows simple cable connections between bays. The primary power/distribution bay or primary power only bay may be placed in the middle of

the bay line-up, expanding the system to the left and right of the primary power/distribution bay or primary power only bay. In this configuration, bay-to-bay cabling MUST start with the primary power/distribution bay or primary power only bay, then each secondary power/distribution bay or secondary power only bay and distribution only bays are daisy-chained into the cabling string.

4.2 Placing and Securing List 101 and List 111 Power/Distribution Bays (without PDSC)



NOTE! *If you are installing List 102 and List 112 bays (with List 130, 131, or 132 PDSC), skip this procedure and refer to “Placing and Securing List 102 and List 112 Power/Distribution Bays (with PDSC)” starting on page 5.*

- PDSC = AC Input 'Power Distribution Service Cabinet'.
- Refer to **Figure 4.1** through **Figure 4.18** as this procedure is performed. **Figure 4.1** provides a floor hole drilling pattern.
- Bays are typically placed next to each other and bolted together. Refer to “General Requirements” on page 3, for bay line-up recommendations.

Procedure

Preparing the Bays

1. Remove all front rectifier mounting position blank cover panels from each power/distribution bay to provide access to bay's floor mounting holes and leveling feet. Cover panels will be re-installed in empty rectifier mounting positions after all rectifiers are installed. **To do so:** Remove the screws and ground washers securing the cover panel. Remove the cover panel.
2. Remove the three rear cover panels from each power/distribution bay. These cover panels will be re-installed after all mounting and electrical connection procedures have been completed. **To do so:** Top Panel: Loosen the screws securing the cover panel. Lift the cover panel until the screw heads clear the keyhole slots. Remove the cover panel. Lower Panels: Remove the screws and ground washers securing the panel. Remove the panel.
3. Remove the side cover panels from each power/distribution bay (two per side) as follows, if equipped. Note that you may leave the side cover panels on the "outside side" of the two end bays.
 - a) **Remove the rear-most side cover panel as follows:** Remove the screws and ground washers securing the side cover panel. Screws are accessible from the rear of the bay through holes in the side channels. After removing screws, pivot rear edge of cover panel outward, then slide cover panel toward rear of bay to disengage tabs at the front of the cover panel from slots in the bay.
 - b) **Remove the front-most side cover panel as follows:** Open the bay's front door. Remove the screws and ground washers securing the side cover panel. Screws are accessible from the front of the bay through holes in the side channels. After removing screws, pivot front edge of cover panel outward, then slide cover panel toward front of bay to disengage tabs at the rear of the cover panel from slots in the bay.

Placing and Securing the Bay(s)

1. Place bay(s) in position. Note that clearance holes for 1/4" bolts are provided in the side rails of each bay. These holes are for bolting the bays together.
2. Level bay(s) as required, using leveling feet in base plate. Adjust leveling feet so that all bays are even at top, and bolt holes in the side of each bay line up with holes in the adjacent bay(s).
3. Bolt all bays together. Use 1/4" hardware, six places per pair of bays. Use a ground washer in two locations with the 1/4" hardware bolting two bays together.



NOTE! A ground washer is an internal-external tooth, dish-type lock washer. When installing ground washers, ensure that the ground washer is oriented so that the teeth dig into the paint on the metal part the ground washer is secured to (concave side faces the metal part).

4. Install shims between bottom of each bay and the floor as required to distribute floor loading.
5. Secure bay(s) to floor using fastening hardware per site requirements.



ALERT! NEBS Zone 4 seismic compliance requires the use of a hardened 2" square washer 0.25" thick with the appropriate internal hole diameter per securement hardware of site requirements or equivalent.

Installing Side Cover Panels on End Bays

1. If the outside sides of the end bays do not have side cover panels, install them now (two per side). Note that ground washers are used with each screw securing the side cover panels.
 - a) **Install the rear-most side cover panel as follows:** Insert tabs at front of cover panel into slots in bay. Pivot cover panel into position against side of bay. Install the previously removed screws and ground washers into cover panel from rear of bay.
 - b) **Install the front-most side cover panel as follows:** Open the bay's front door. Insert tabs at rear of cover panel into slots in bay. Pivot cover panel into position against side of bay. Install the previously removed screws and ground washers into cover panel from front of bay.

4.3 Placing and Securing List 102 and List 112 Power/Distribution Bays (with PDSC)



NOTE! If you are installing List 101 and List 111 Bays (without List 130, 131, or 132 PDSC), skip this procedure and refer to "Placing and Securing List 101 and List 111 Power/Distribution Bays (without PDSC)" starting on page 4.

- PDSC = AC Input 'Power Distribution Service Cabinet'.
- Refer to **Figure 4.1** through **Figure 4.18** as this procedure is performed. **Figure 4.2** provides a floor hole drilling pattern.
- Bays are typically placed next to each other and bolted together. Refer to "General Requirements" on page 3, for bay line-up recommendations. PDSCs are located to the left (as viewed from the front) of each power/distribution bay.

Procedure

Preparing the Bays and PDSCs

1. Remove all front rectifier mounting position blank cover panels from each power/distribution bay to provide access to bay's floor mounting holes and leveling feet. Cover panels will be re-installed in empty rectifier mounting positions after all rectifiers are installed. **To do so:** Remove the screws and ground washers securing the cover panel. Remove the cover panel.
2. Remove the three rear cover panels from each power/distribution bay. These cover panels will be re-installed after all mounting and electrical connection procedures have been completed. **To do so:** Top Panel: Loosen the screws securing the cover panel. Lift the cover panel until the screw heads clear the keyhole slots. Remove the cover panel. Lower Panels: Remove the screws and ground washers securing the panel. Remove the panel.
3. Remove the side cover panels from each power/distribution bay (two per side) as follows, if equipped. Note that you may leave the side cover panels on the "outside side" of the right-most (as viewed from the front) end bay.
 - a) **Remove the rear-most side cover panel as follows:** Remove the screws and ground washers securing the side cover panel. Screws are accessible from the rear of the bay through holes in the side channels. After removing screws, pivot

rear edge of cover panel outward, then slide cover panel toward rear of bay to disengage tabs at the front of the cover panel from slots in the bay.

- b) **Remove the front-most side cover panel as follows:** Open the bay's front door. Remove the screws and ground washers securing the side cover panel. Screws are accessible from the front of the bay through holes in the side channels. After removing screws, pivot front edge of cover panel outward, then slide cover panel toward front of bay to disengage tabs at the rear of the cover panel from slots in the bay.
4. Remove the front cover panel from each PDSC. This cover panel will be re-installed after all mounting and electrical connection procedures have been completed. **To do so:** Remove the screws and ground washers securing the cover panel. Remove the cover panel.
5. Remove the rear lower cover panel from each PDSC. This cover panel will be re-installed after all mounting and electrical connection procedures have been completed. **To do so:** Remove the screws and ground washers securing the cover panel. Remove the cover panel.
6. Remove the rear upper cover panel from each PDSC. This cover panel will be re-installed after all mounting and electrical connection procedures have been completed. **To do so:** Loosen the screws securing the cover panel. Lift the cover panel until the screw heads clear the keyhole slots. Remove the cover panel.
7. Remove the plug-button located on the left side (towards the front) of each PDSC, except the end PDSC. This opening is provided for data communications cable routing between bays.

Placing and Securing the Bay(s) and PDSCs

1. Place bay(s) and PDSC(s) in position. Note that PDSCs are placed to the left (as viewed from the front) of each bay. Note that clearance holes for 1/4" bolts are provided in the side rails of each bay and PDSC. These holes are for bolting the bays and PDSCs together.
2. Level bay(s) and PDSC(s) as required, using leveling feet in base plate. Adjust leveling feet so that all bays and PDSCs are even at top, and bolt holes in the side of each bay and PDSC line up with holes in the adjacent cabinet(s).
3. Bolt all bays and PDSCs together. Use 1/4" hardware, five places per pair of cabinets. Use a ground washer in two locations with the 1/4" hardware bolting two cabinets together.



NOTE! *A ground washer is an internal-external tooth, dish-type lock washer. When installing ground washers, ensure that the ground washer is oriented so that the teeth dig into the paint on the metal part the ground washer is secured to (concave side faces the metal part).*

4. Install shims between bottom of each bay and the floor as required to distribute floor loading.
5. Secure Power/Distribution Bay(s) and PDSC(s) to floor using fastening hardware per site requirements.



ALERT! NEBS Zone 4 seismic compliance requires the use of a hardened 2" square washer 0.25" thick with the appropriate internal hole diameter per securement hardware of site requirements or equivalent.

Installing Side Cover Panels on Right-Most End Bay

6. If the outside side of the right-most end bay does not have side cover panels, install them now (two per side). Note that ground washers are used with each screw securing the side cover panels.
 - a) **Install the rear-most side cover panel as follows:** Insert tabs at front of cover panel into slots in bay. Pivot cover panel into position against side of bay. Install the previously removed screws and ground washers into cover panel from rear of bay.

- b) **Install the front-most side cover panel as follows:** Open the bay's front door. Insert tabs at rear of cover panel into slots in bay. Pivot cover panel into position against side of bay. Install the previously removed screws and ground washers into cover panel from front of bay.

4.4 Placing and Securing List 103, 104, 105, 113, 114, and 115 Power Only Bays

- Refer to **Figure 4.1** through **Figure 4.18** as this procedure is performed. **Figure 4.1** provides a floor hole drilling pattern.
- Bays are typically placed next to each other and bolted together. Refer to "General Requirements" on page 3, for bay line-up recommendations.

Procedure

1. Remove all front rectifier mounting position blank cover panels from each power only bay to provide access to bay's floor mounting holes and leveling feet. Cover panels will be re-installed in empty rectifier mounting positions after all rectifiers are installed. **To do so:** Remove the screws and ground washers securing the cover panel. Remove the cover panel.
2. Remove the three rear cover panels from each power only bay. These cover panels will be re-installed after all mounting and electrical connection procedures have been completed. To do so: Top Panel: Loosen the screws securing the cover panel. Lift the cover panel until the screw heads clear the keyhole slots. Remove the cover panel. Lower Panels: Remove the screws and ground washers securing the panel. Remove the panel.
3. Remove the side cover panels from each power only bay (two per side) as follows, if equipped. Note that you may leave the side cover panels on the "outside side" of the two end bays.
 - a) **Remove the rear-most side cover panel as follows:** Remove the screws and ground washers securing the side cover panel. Screws are accessible from the rear of the bay through holes in the side channels. After removing screws, pivot rear edge of cover panel outward, then slide cover panel toward rear of bay to disengage tabs at the front of the cover panel from slots in the bay.
 - b) **Remove the front-most side cover panel as follows:** Open the bay's front door. Remove the screws and ground washers securing the side cover panel. Screws are accessible from the front of the bay through holes in the side channels. After removing screws, pivot front edge of cover panel outward, then slide cover panel toward front of bay to disengage tabs at the rear of the cover panel from slots in the bay.
4. Place bay(s) in position. Note that clearance holes for 1/4" bolts are provided in the side rails of each bay. These holes are for bolting the bays together.
5. Level bay(s) as required, using leveling feet in base plate. Adjust leveling feet so that all bays are even at top, and bolt holes in the side of each bay line up with holes in the adjacent bay(s).
6. Bolt all bays together. Use 1/4" hardware, six places per pair of bays. Use a ground washer in two locations with the 1/4" hardware bolting two bays together.



NOTE! *A ground washer is an internal-external tooth, dish-type lock washer. When installing ground washers, ensure that the ground washer is oriented so that the teeth dig into the paint on the metal part the ground washer is secured to (concave side faces the metal part).*

7. Install shims between bottom of each bay and the floor as required to distribute floor loading.
8. Secure bay(s) to floor using fastening hardware per site requirements.



ALERT! NEBS Zone 4 seismic compliance requires the use of a hardened 2" square washer 0.25" thick with the appropriate internal hole diameter per securement hardware of site requirements or equivalent.

9. If the outside sides of the end bays do not have side cover panels, install them now (two per side). Note that ground washers are used with each screw securing the side cover panels.
 - a) **Install the rear-most side cover panel as follows:** Insert tabs at front of cover panel into slots in bay. Pivot cover panel into position against side of bay. Install the previously removed screws and ground washers into cover panel from rear of bay.
 - b) **Install the front-most side cover panel as follows:** Open the bay's front door. Insert tabs at rear of cover panel into slots in bay. Pivot cover panel into position against side of bay. Install the previously removed screws and ground washers into cover panel from front of bay.

4.5 Placing and Securing List 116, 117, 118, and 122 Distribution Only Bays

- Refer to **Figure 4.1** through **Figure 4.18** as this procedure is performed. **Figure 4.3** provides a hole drilling pattern.
- Bays are typically placed next to each other and bolted together. Refer to "General Requirements" on page 3, for bay line-up recommendations.

Procedure:

Preparing the Bays

1. Remove the two rear cover panels from each distribution only bay. These cover panels will be re-installed after all mounting and electrical connection procedures have been completed. To do so: Remove the screws securing the panel, and remove the panel.
2. Remove the two side cover panels from each distribution only bay, if equipped. Note that you may leave the side cover panels on the "outside side" of the two end bays. To do so: Remove the screws and ground washers securing the panel, and remove the panel.

Placing and Securing the Bay(s)

1. Prepare the "1st Distribution Only Bay's" interconnect busbars.



NOTE! Apply electrical anti-oxidation compound to mating surfaces of busbars before connecting together.

2. Place bay(s) in position. Note that clearance holes for 1/4" bolts are provided in the side rails of each bay. These holes are for bolting the bays together.
3. Level bay(s) as required, using leveling feet in base plate. Adjust leveling feet so that all bays are even at top, and bolt holes in the side of each bay line up with holes in the adjacent bay(s).
4. Secure the "1st Distribution Only Bay's" interconnect busbars to the adjacent power/distribution bay's busbars (hand-tighten connections only).
5. Install and secure "2nd and Beyond Distribution Only Bays" interconnect busbars (hand-tighten connections only).
6. Bolt all bays together. Use 1/4" hardware, six places per pair of bays. Use a ground washer in two locations with the 1/4" hardware bolting two bays together.



NOTE! A ground washer is an internal-external tooth, dish-type lock washer. When installing ground washers, ensure that the ground washer is oriented so that the teeth dig into the paint on the metal part the ground washer is secured to (concave side faces the metal part).

7. Install shims between bottom of each bay and the floor as required to distribute floor loading.
8. Secure bay(s) to floor using fastening hardware per site requirements.



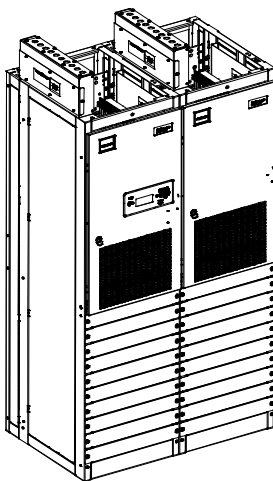
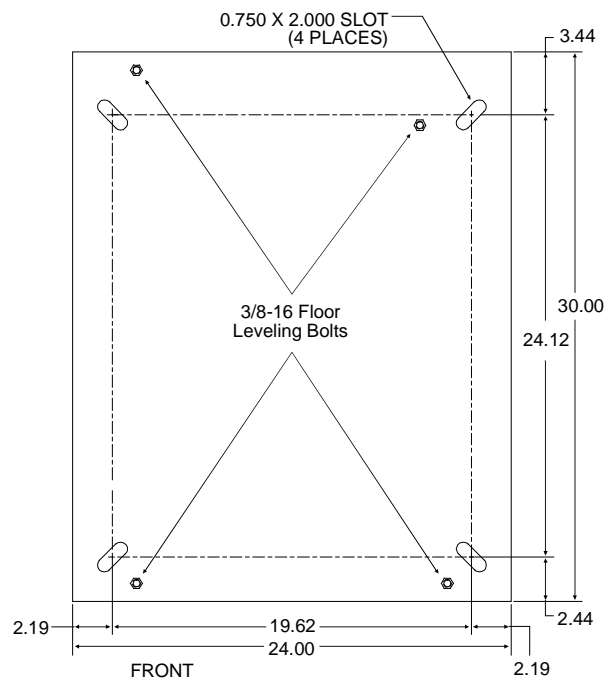
ALERT! NEBS Zone 4 seismic compliance requires the use of a hardened 2" square washer 0.25" thick with the appropriate internal hole diameter per securement hardware of site requirements or equivalent.

9. Torque the bolts securing the "1st Distribution Only Bay's" interconnect busbars to the adjacent power/distribution bay's busbars. Refer to the following illustrations for torque values.
10. Torque the bolts securing the "2nd and Beyond Distribution Only Bays" interconnect busbars. Refer to the following illustrations for torque values.

Installing Side Cover Panels on End Bays

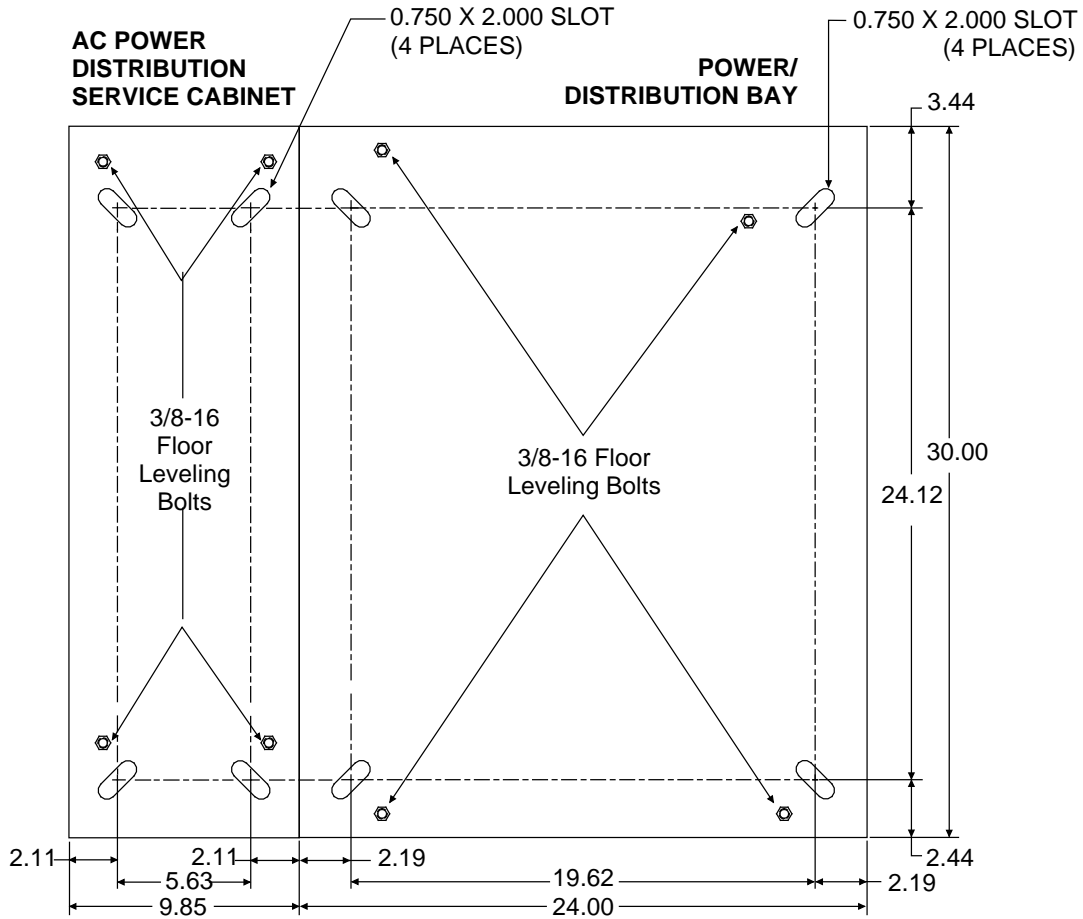
1. If the outside sides of the end bays do not have side cover panels, install them now (two per side). Note that ground washers are used with each screw securing the side cover panels. To do so: Insert tabs on cover panels into slots in bay. Install the previously removed screws and ground washers to secure each cover panel.

Figure 4.1 Floor Mounting Hole Dimensions (Primary and Secondary Power/Distribution Bays without PDSC) (Power Only Bays Have the Same Hole Pattern) (all dimensions in inches)

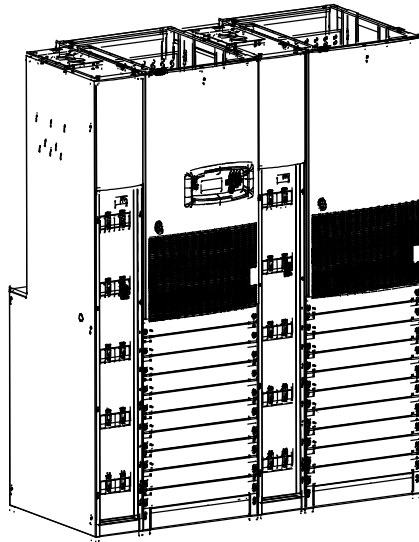


Floor Hole Drilling Pattern
Power/Distribution Bay

Figure 4.2 Floor Mounting Hole Dimensions (Primary and Secondary Power/Distribution Bays with PDSC) (all dimensions in inches)



FRONT



Floor Hole Drilling Pattern
Power/Distribution Bay
and PDSC

Figure 4.3 Floor Mounting Hole Dimensions - Distribution Only Bay (all dimensions in inches)

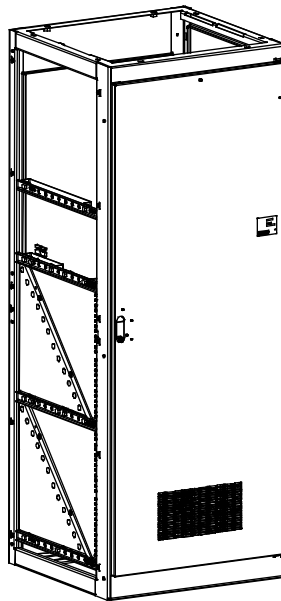
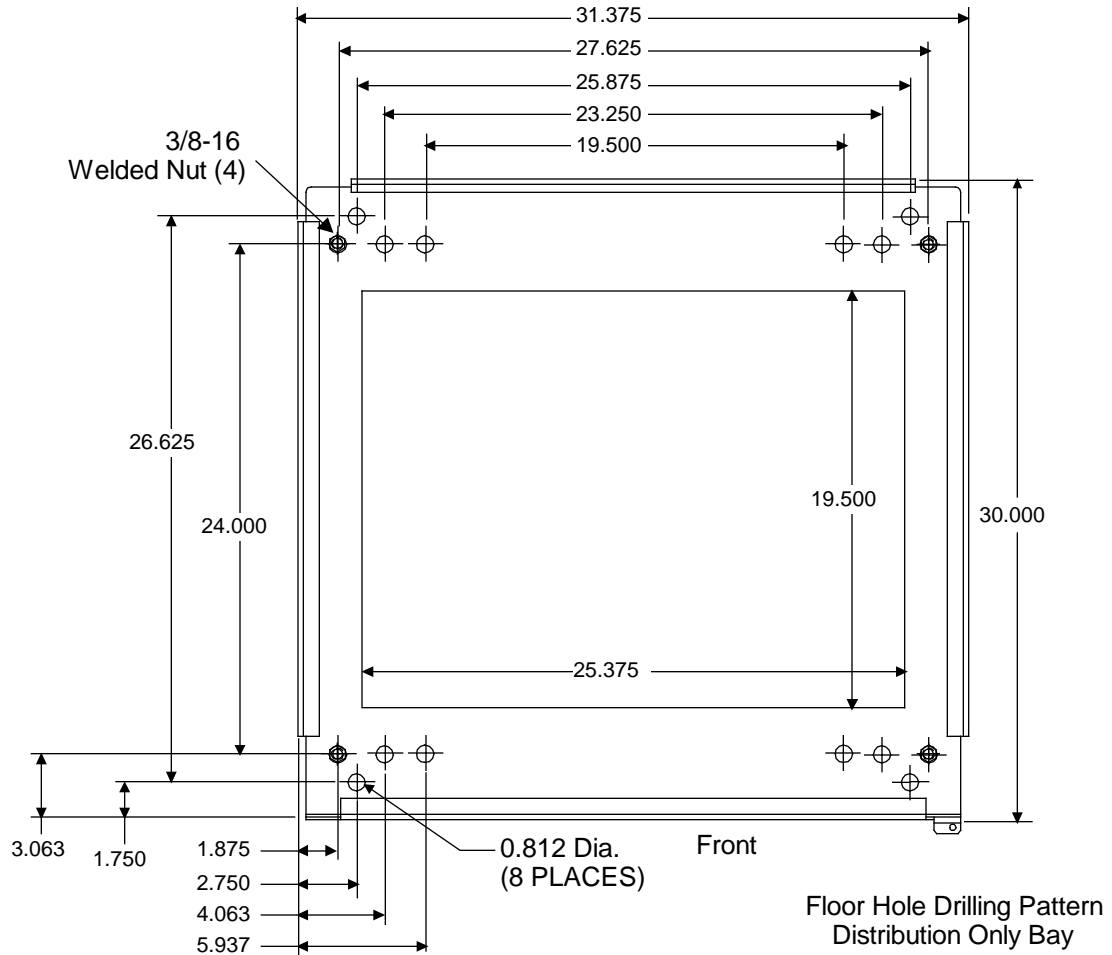


Figure 4.4 Removing Rectifier Mounting Position Blank Cover Panels from Power/Distribution Bay

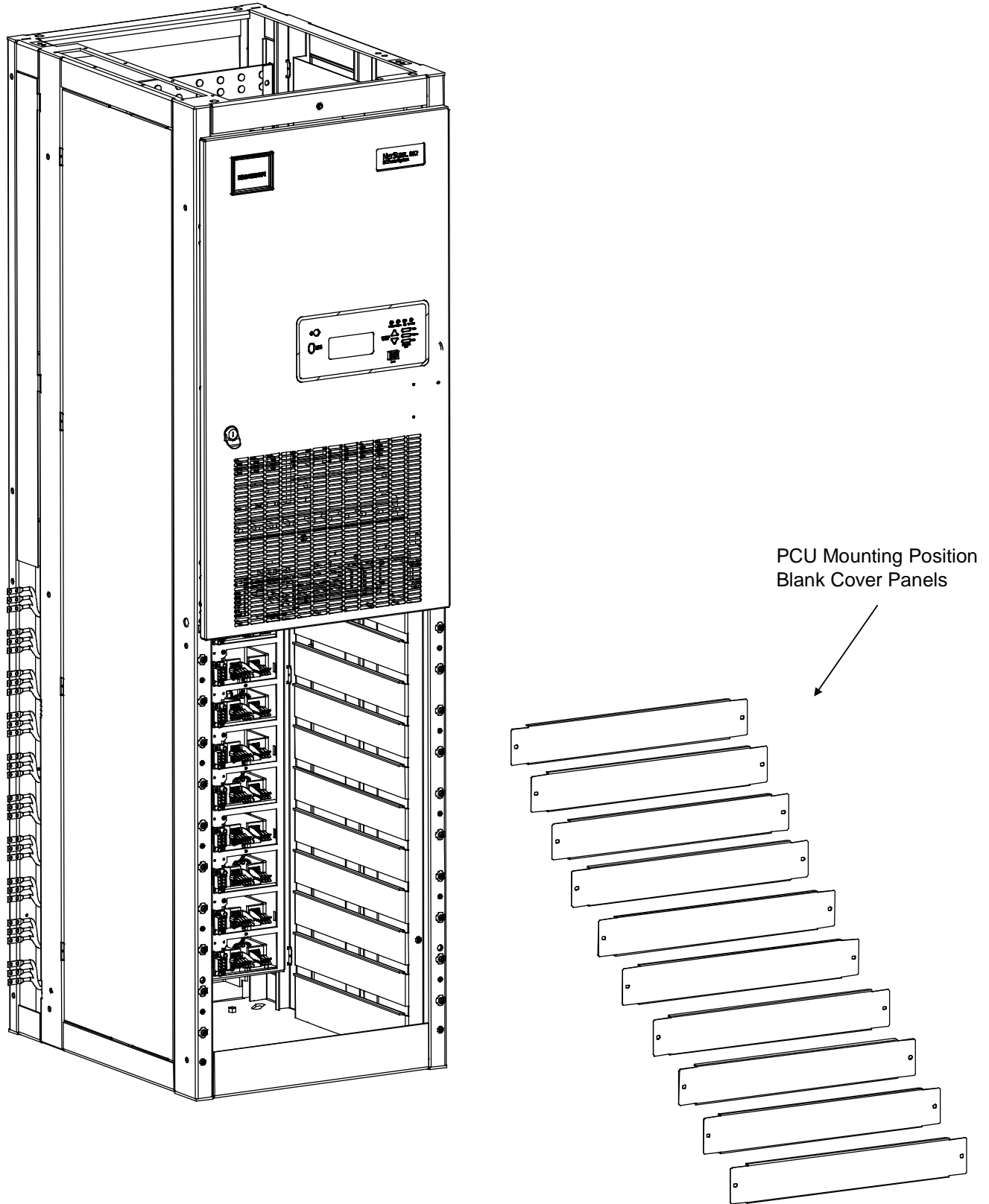


Figure 4.5 Removing Rear Cover Panels from Power/Distribution Bay

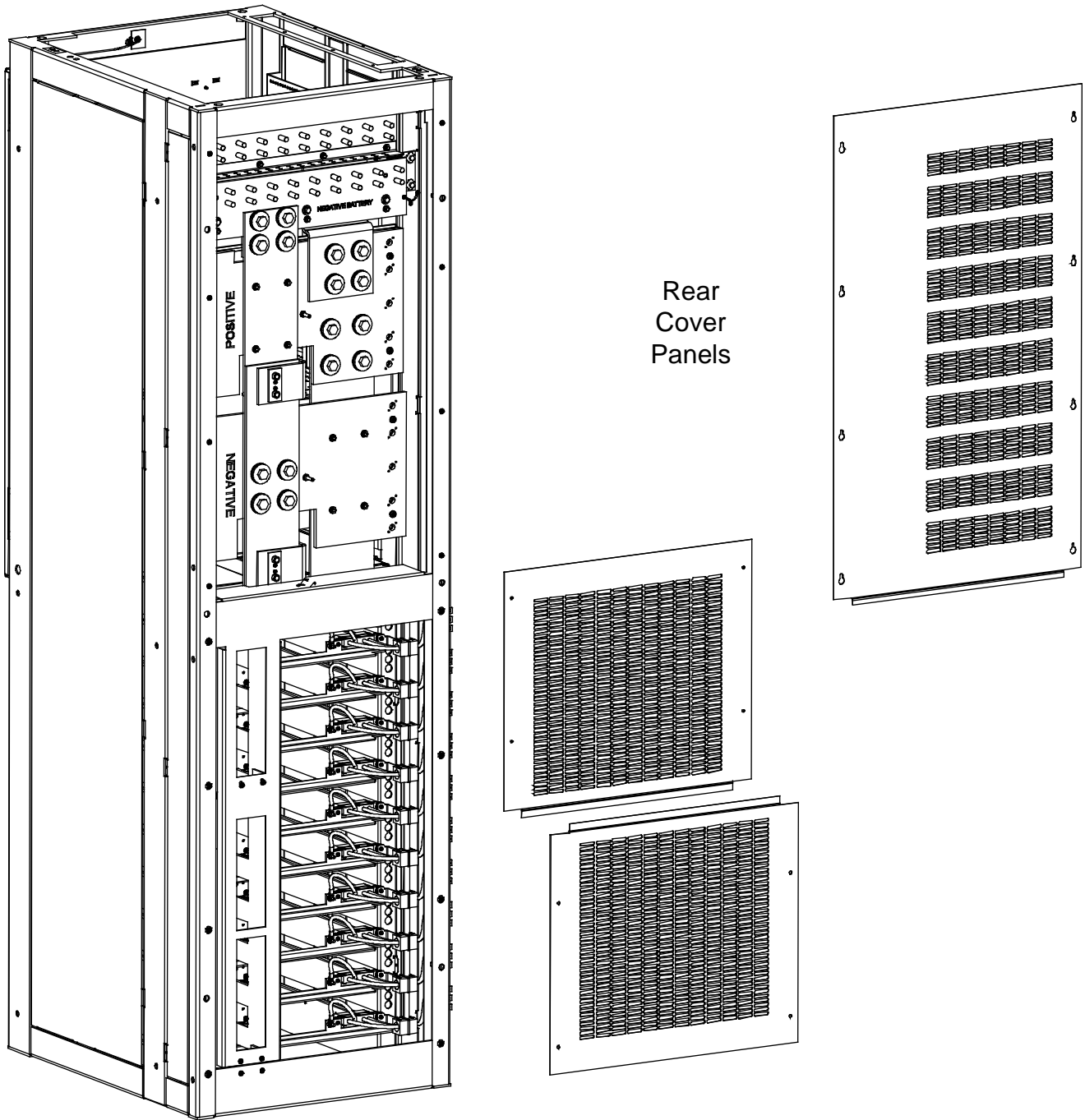


Figure 4.6 Removing Side Cover Panels from Power/Distribution Bay

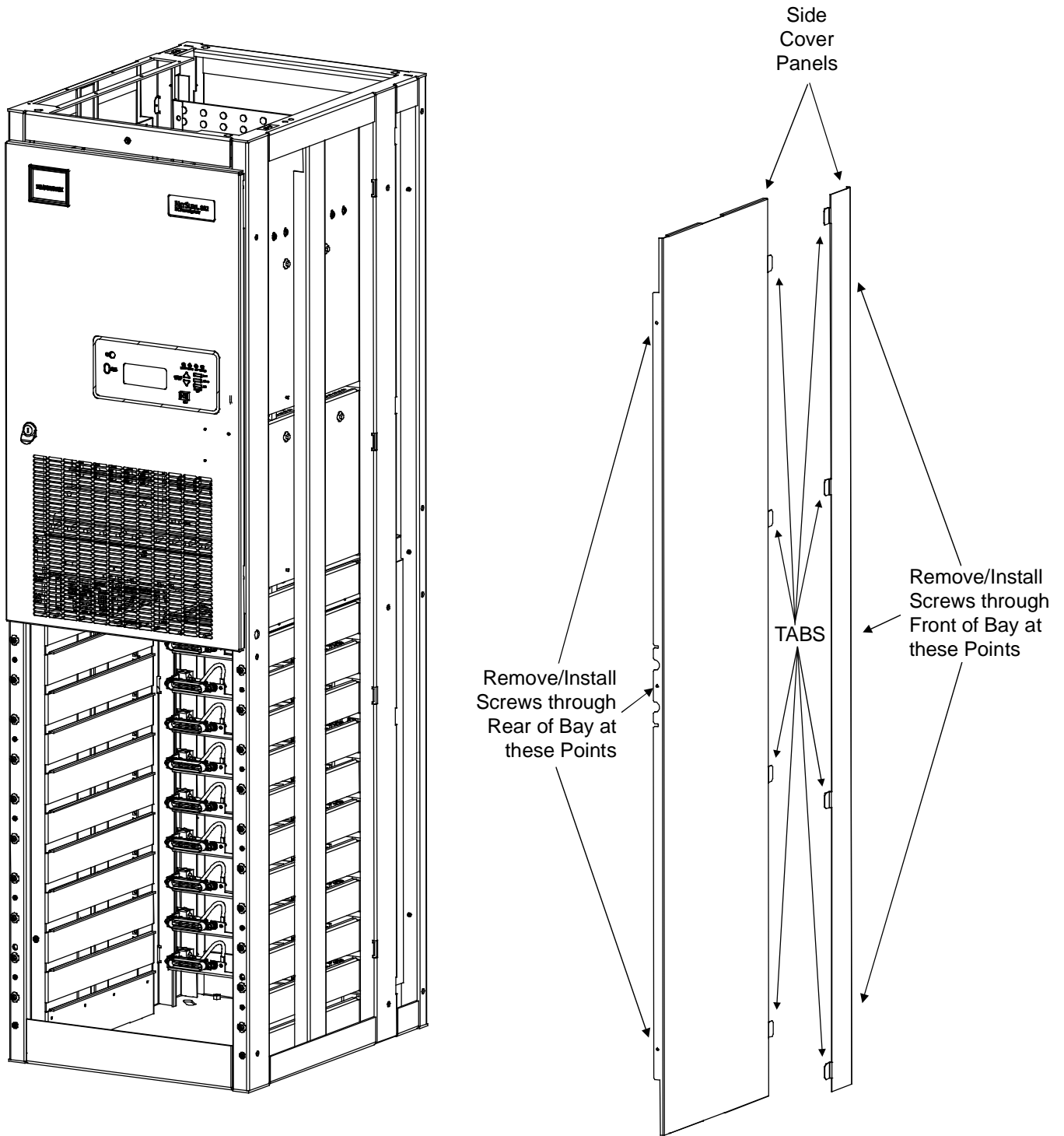


Figure 4.7 Removing Front and Rear Cover Panels, and Plug-Button from PDSC (AC Input 'Power Distribution Service Cabinet')

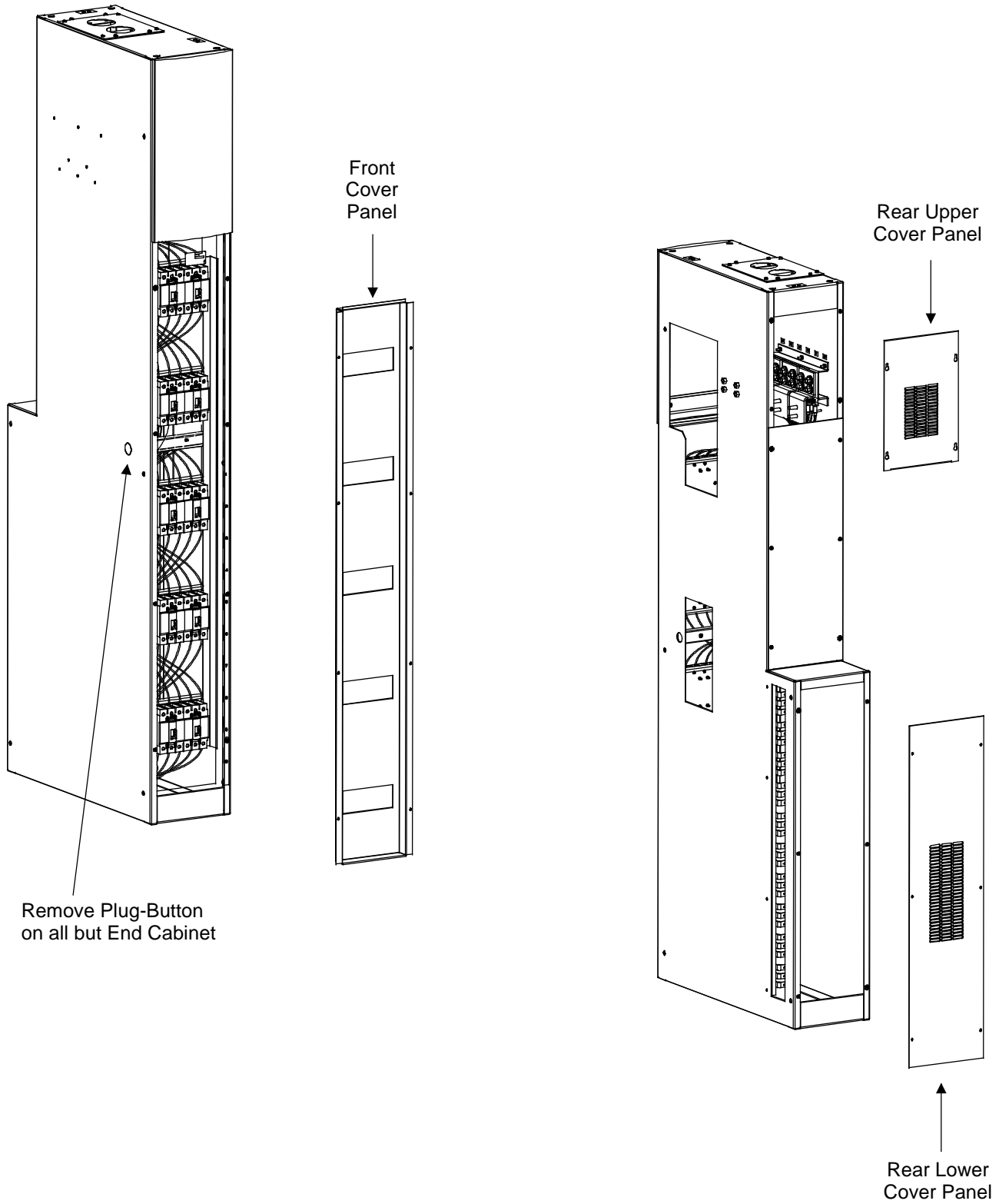


Figure 4.8 Removing Rear and Side Cover Panels from Distribution Only Bay

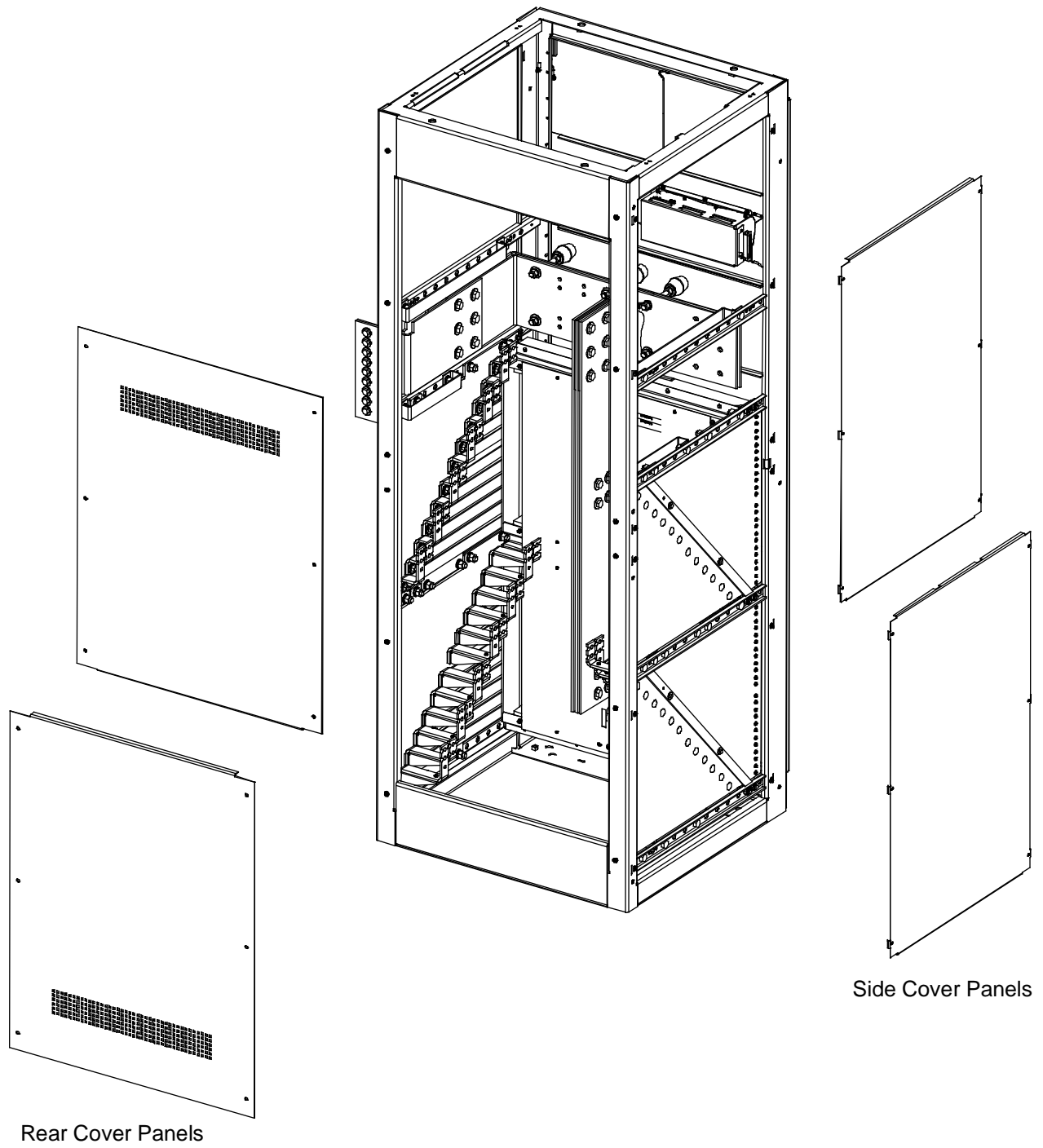
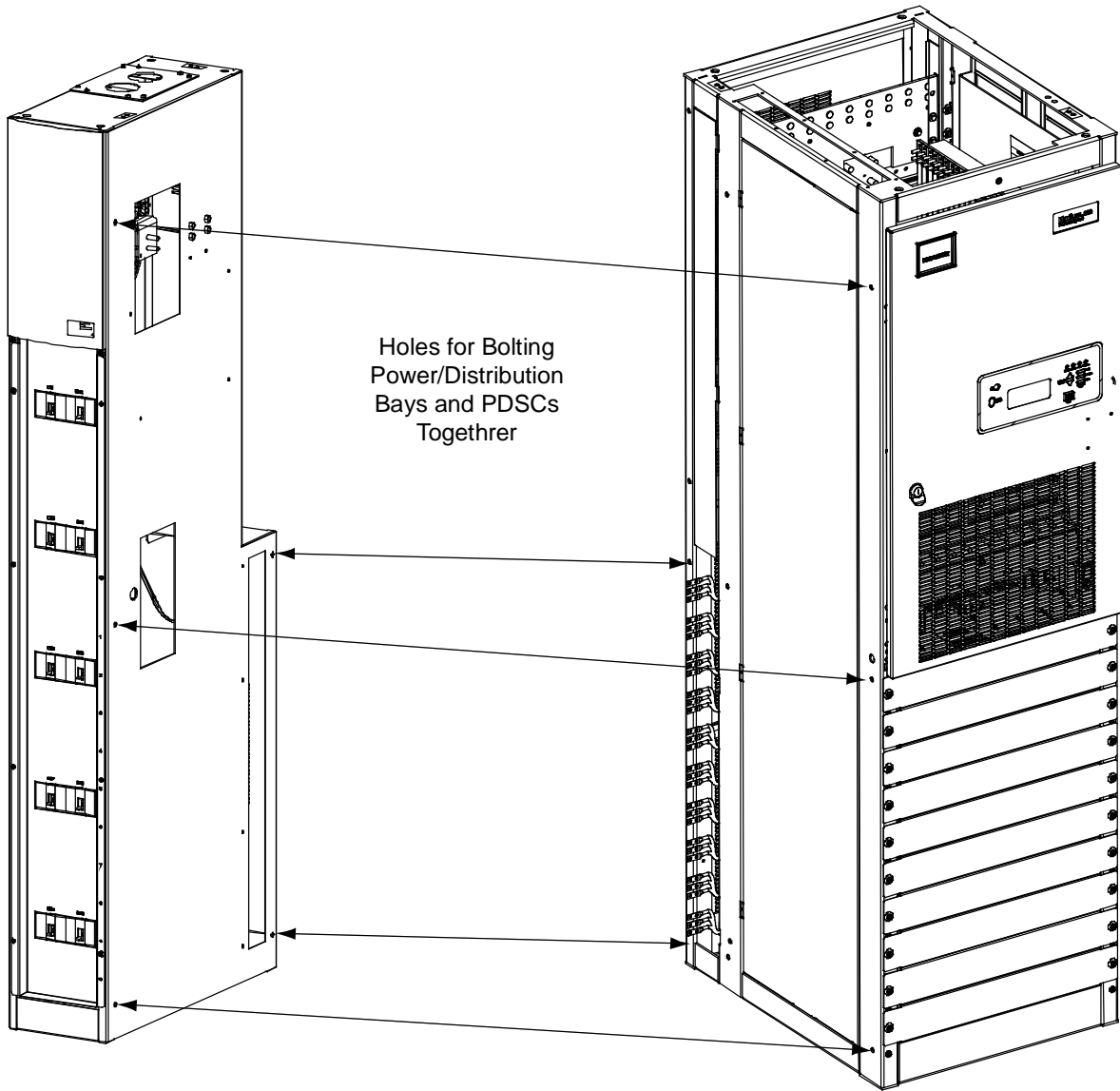
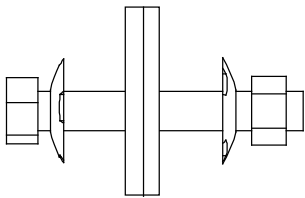


Figure 4.9 Bolting Power/Distribution Bay to PDSC Cabinet



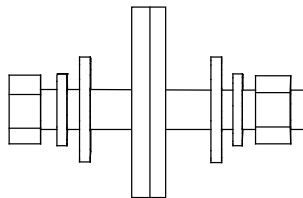
Holes for Bolting
Power/Distribution
Bays and PDSCs
Together

Bay/Cabinet Sides



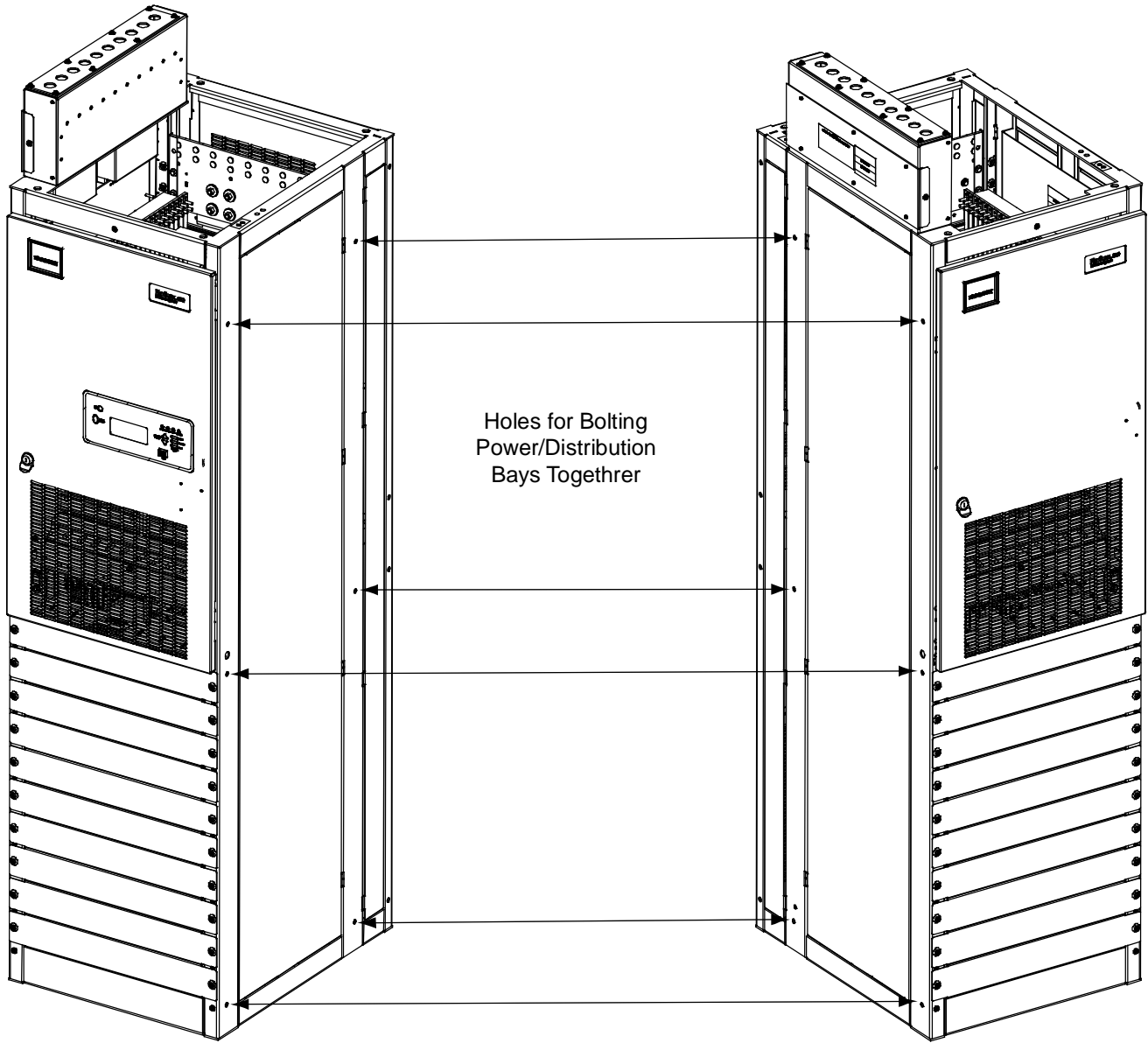
Hardware Build-Up: (use ground washers
in center tie points each side)
Bolt, Ground Washer, Bay/Cabinet Sides,
Ground Washer, Nut

Bay/Cabinet Sides

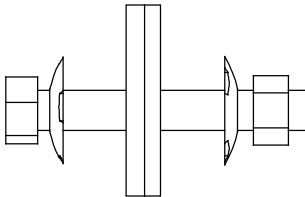


Hardware Build-Up: (use in remaining connection points)
Bolt, Lock Washer, Flat Washer, Bay/Cabinet Sides,
Flat Washer, Lock Washer, Nut

Figure 4.10 Bolting Power/Distribution Bay to Power/Distribution Bay

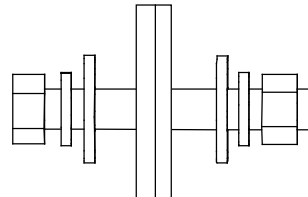


Bay/Bay Sides



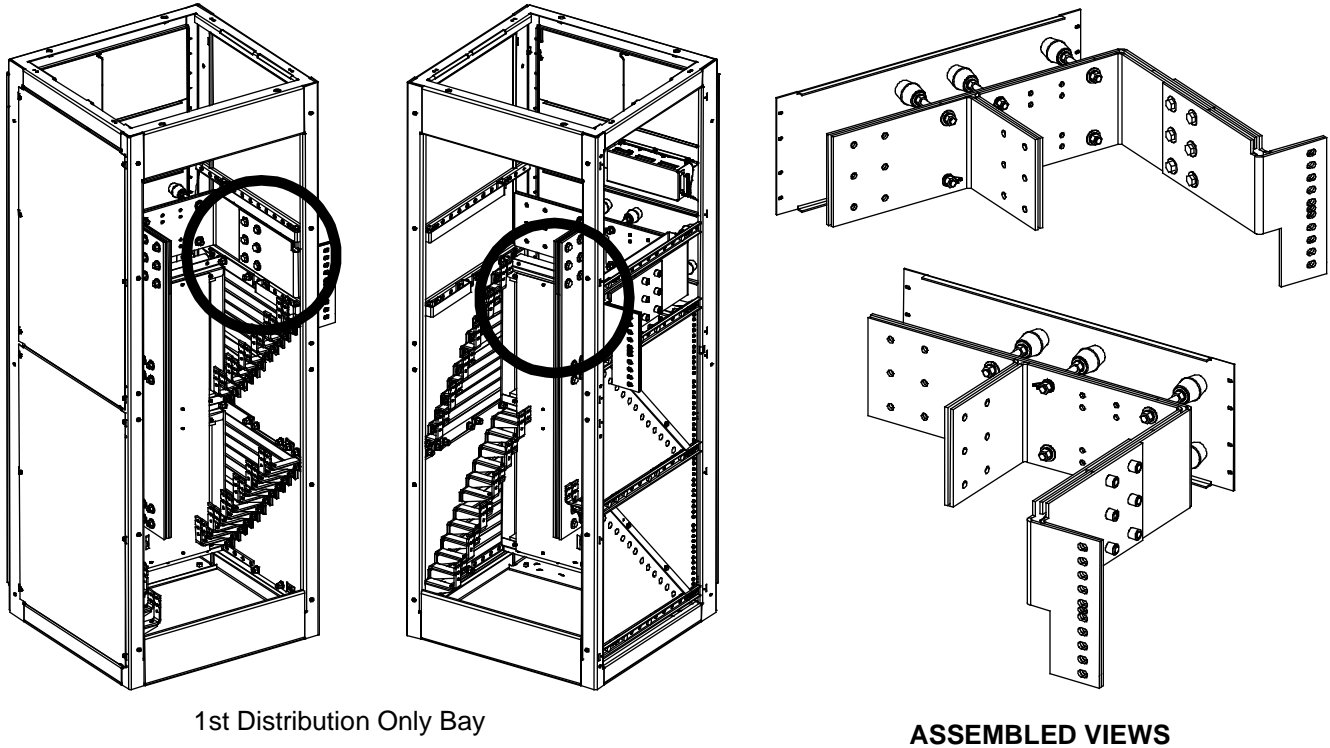
Hardware Build-Up: (use ground washers in center tie points each side)
Bolt, Ground Washer, Bay/Cabinet Sides, Ground Washer, Nut

Bay/Bay Sides



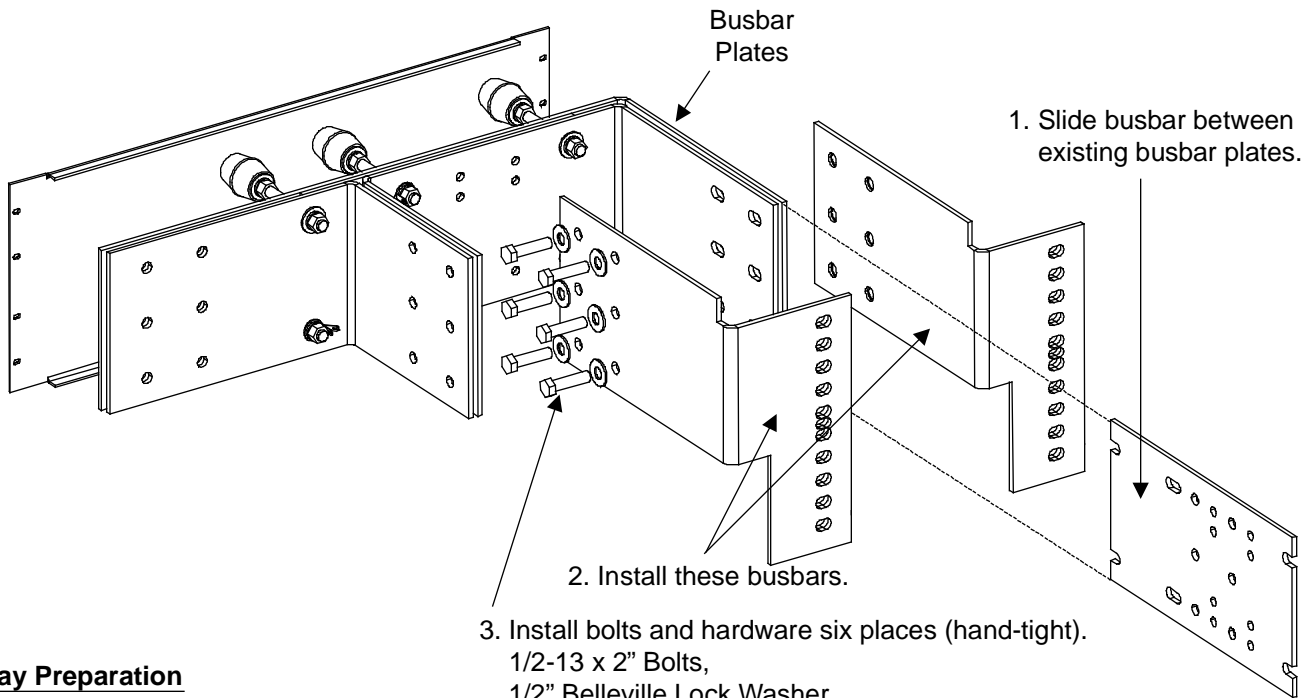
Hardware Build-Up: (use in remaining connection points)
Bolt, Lock Washer, Flat Washer, Bay/Cabinet Sides, Flat Washer, Lock Washer, Nut

Figure 4.11 Bolting Power/Distribution Bay to Distribution Only Bay



1st Distribution Only Bay

ASSEMBLED VIEWS



Busbar Plates

1. Slide busbar between existing busbar plates.

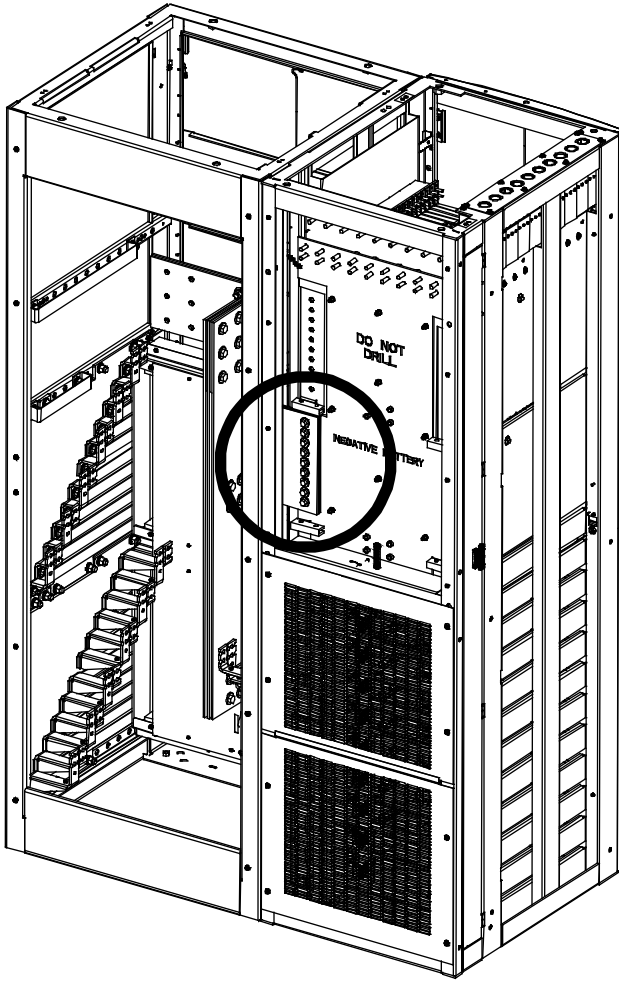
2. Install these busbars.

3. Install bolts and hardware six places (hand-tight).
 1/2-13 x 2" Bolts,
 1/2" Belleville Lock Washer,
 Busbars

Bay Preparation

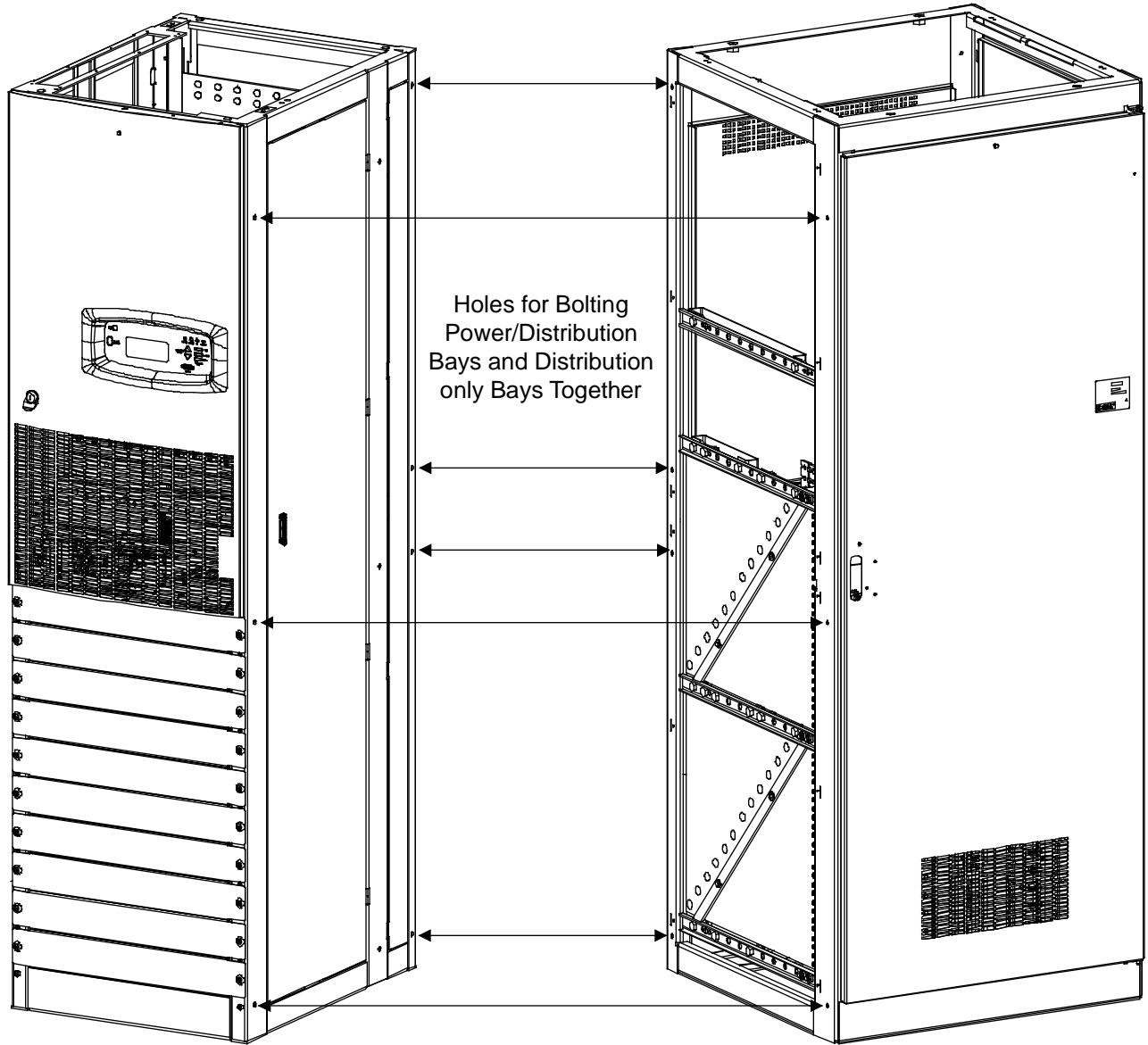
- A. Remove rear cover panels.
- B. Remove side panels on sides of bays that will be palced next to each other.

Figure 4.12 Bolting Power/Distribution Bay to Distribution Only Bay

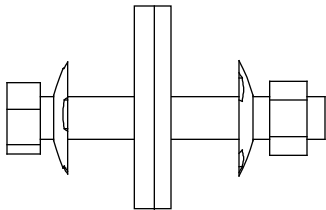


4. Slide bays together, aligning holes in busbars just installed with holes in negative battery busbars on Power/Distribution Bay.
5. Install bolts and hardware nine places (hand-tight) to secure Distribution Only Bay busbars to Power/Distribution Bay busbars.
3/8-16 x 1-1/4" Bolt,
3/8" Belleville Lock Washer,
Busbars
6. After bays are bolted together, torque 1/2" bolts (securing busbars on Distribution Only Bay) to 200 in-lbs, and 3/8" bolts (securing Distribution Only Bay busbars to Power/Distribution Bay negative battery busbar) to 180 in-lbs.

Figure 4.13 Bolting Power/Distribution Bay to Distribution Only Bay

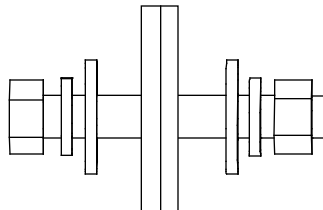


Bay/Bay Sides



Hardware Build-Up: (use ground washers in center tie points each side)
 Bolt, Ground Washer, Bay/Cabinet Sides, Ground Washer, Nut

Bay/Bay Sides



Hardware Build-Up: (use in remaining connection points)
 Bolt, Lock Washer, Flat Washer, Bay/Cabinet Sides, Flat Washer, Lock Washer, Nut

Figure 4.14 Bolting Distribution Only Bays Together

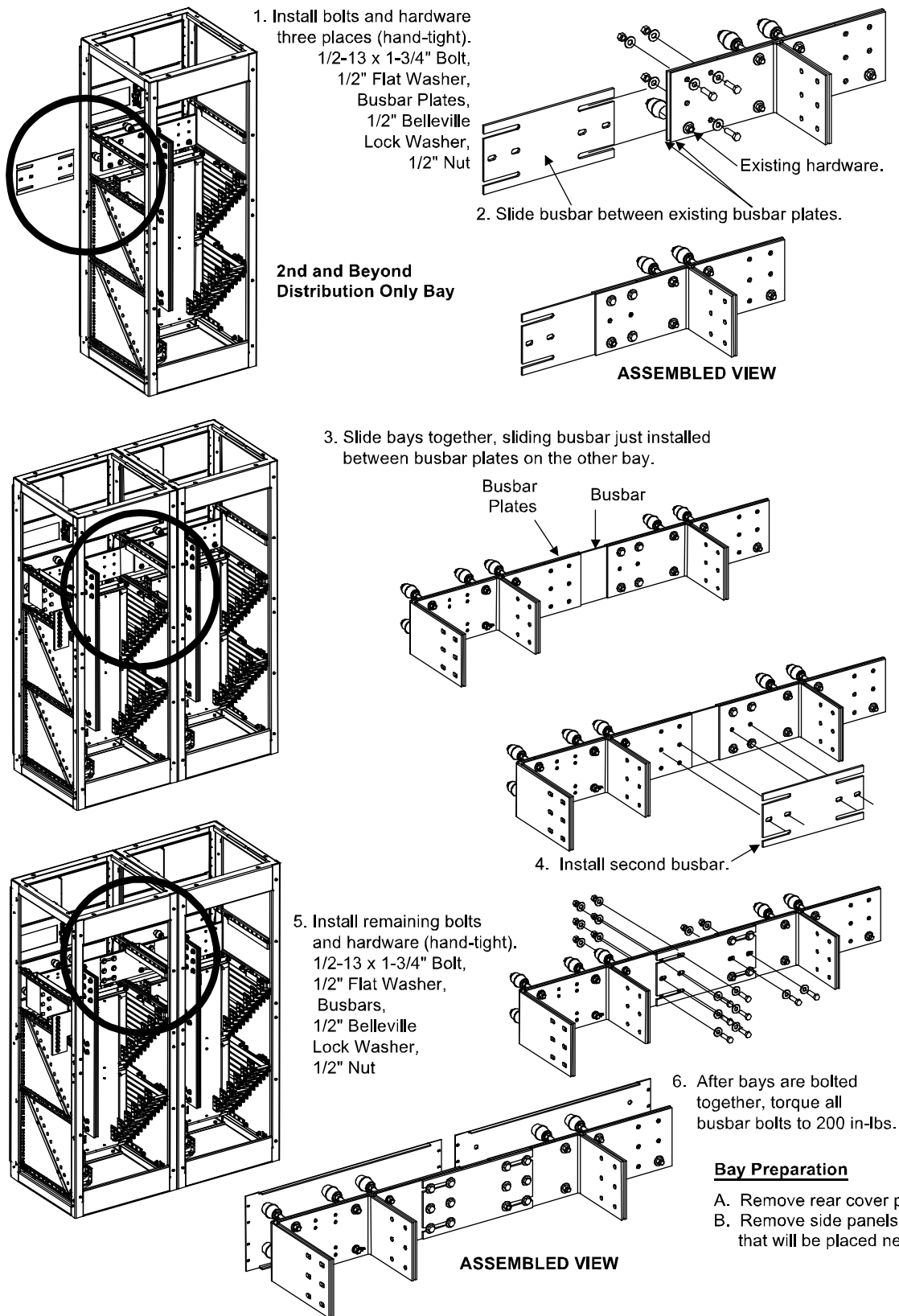
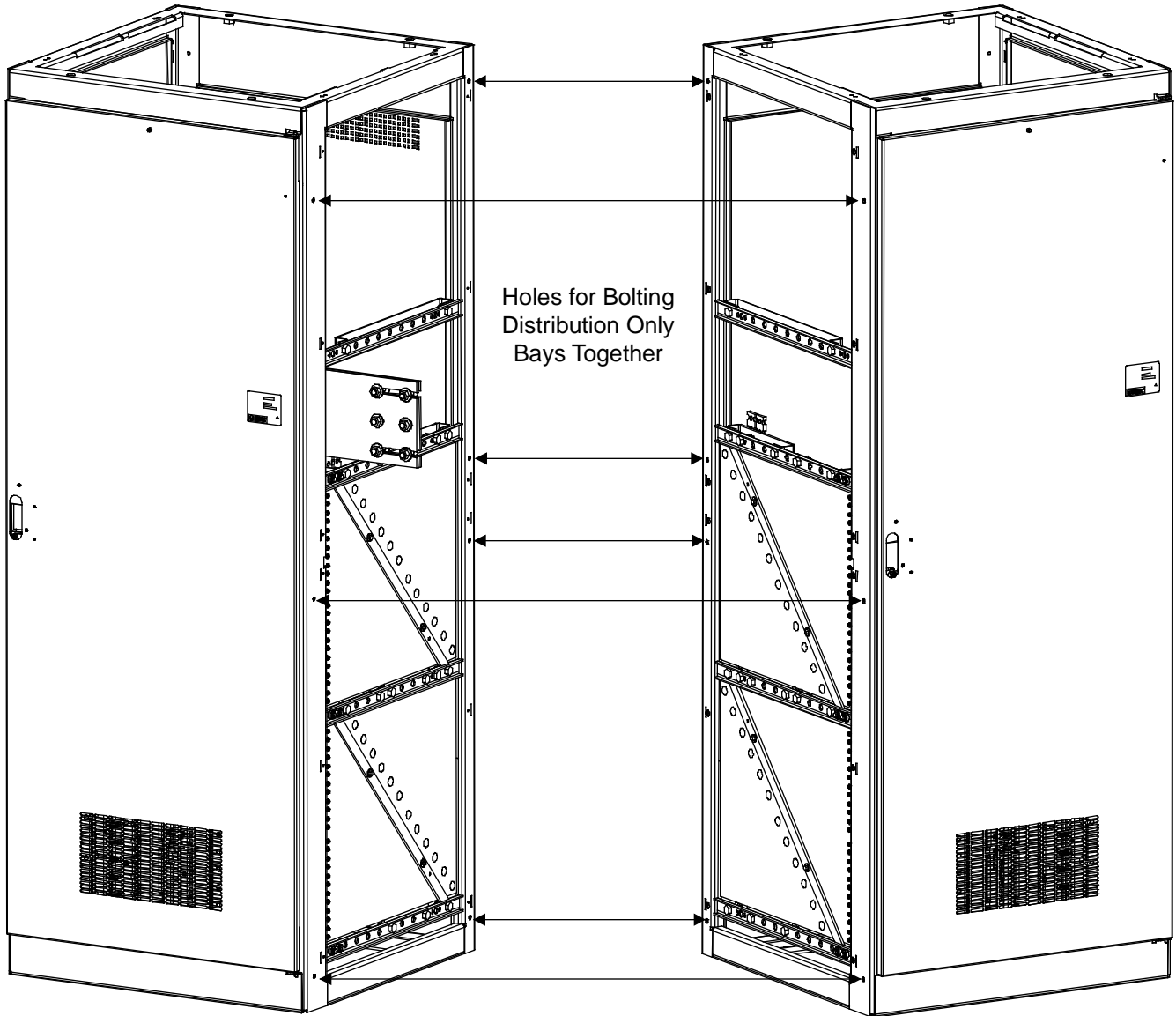
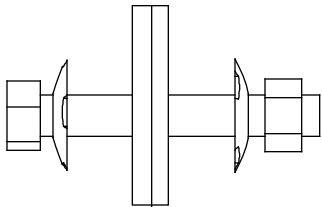


Figure 4.15 Bolting Distribution Only Bays Together

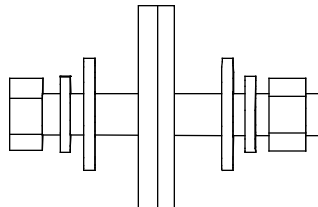


Bay/Bay Sides



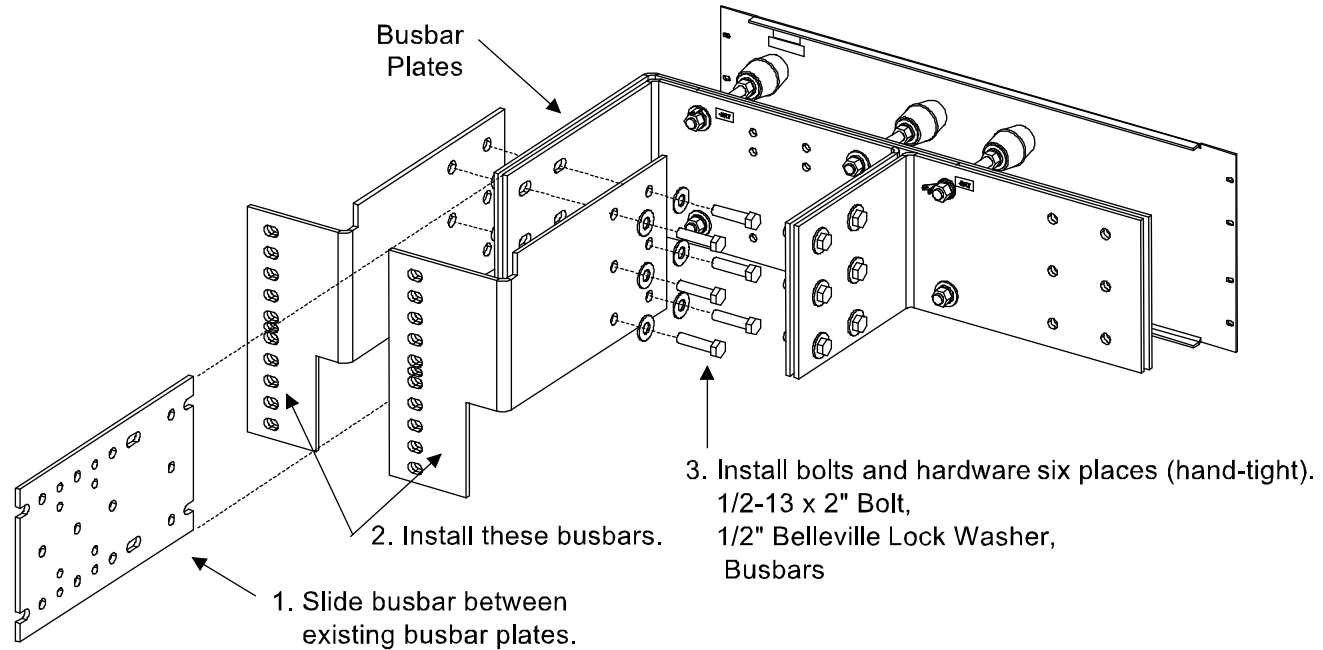
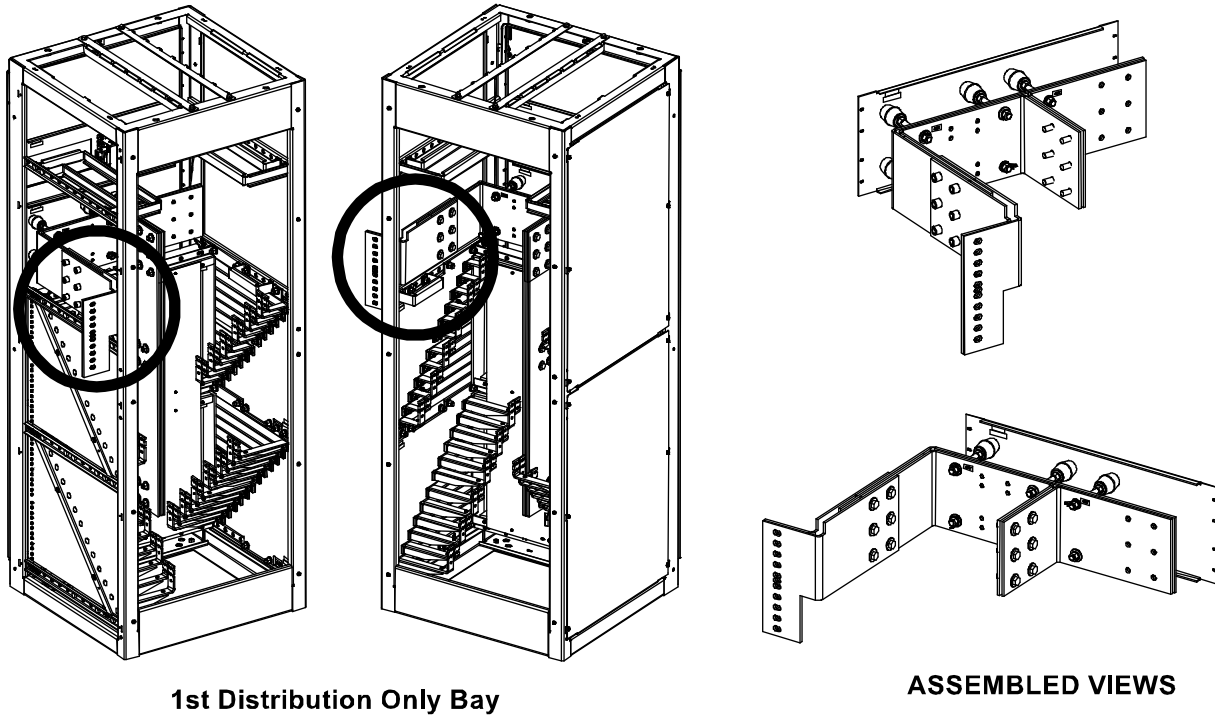
Hardware Build-Up: (use ground washers in center tie points each side)
 Bolt, Ground Washer, Bay/Cabinet Sides, Ground Washer, Nut

Bay/Bay Sides



Hardware Build-Up: (use in remaining connection points)
 Bolt, Lock Washer, Flat Washer, Bay/Cabinet Sides, Flat Washer, Lock Washer, Nut

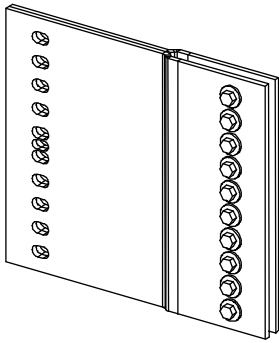
Figure 4.16 Bolting Distribution Only Bay to PDSC (AC Input 'Power Distribution Service Cabinet')



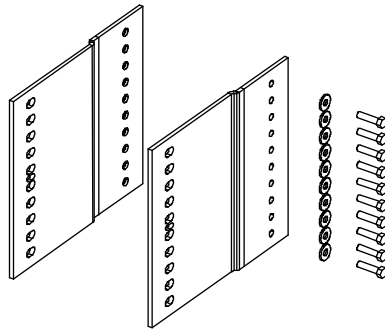
Bay Preparation

- A. Remove rear cover panels.
- B. Remove side panels on sides of bays that will be placed next to each other.

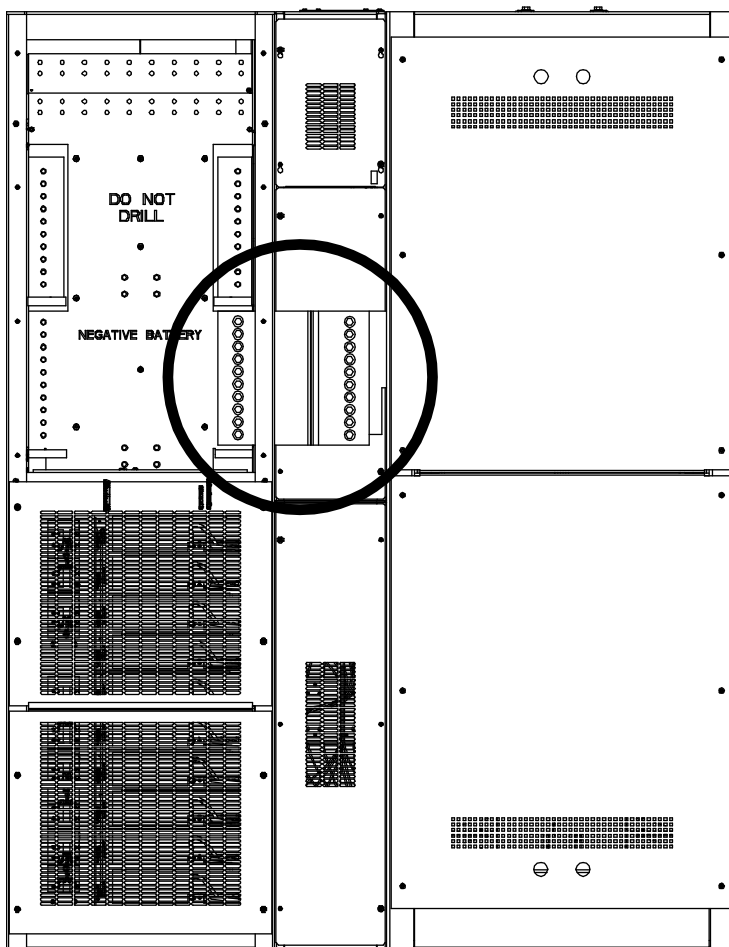
Figure 4.17 Bolting Distribution Only Bay to PDSC (AC Input 'Power Distribution Service Cabinet')



ASSEMBLED VIEWS

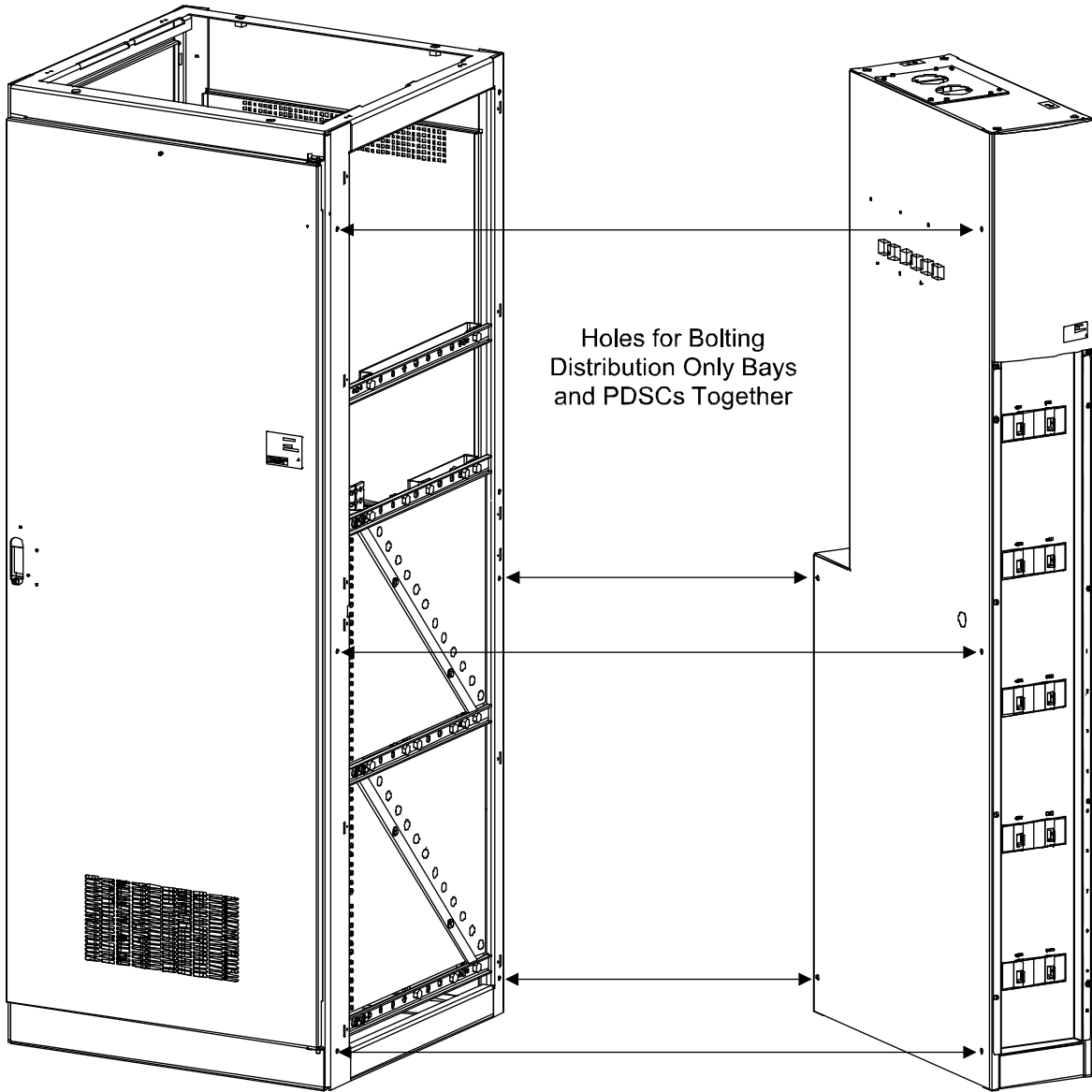


List 19 Expansion Busbars

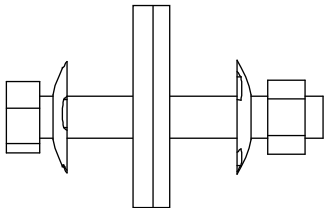
Power/Distribution
BayPDSC
CabinetDistribution
Only Bay

1. Assemble List 19 Expansion Busbars as illustrated above, and connect to appropriate busbars in Distribution Only Bay and Power/Distribution Bay as described in the next steps.
2. Install bolts and hardware ten places (hand-tight) to secure List 19 Expansion Busbars to Distribution Only Bay busbars. 3/8-16 x 1-1/2" Bolt, 3/8" Belleville Lock Washer, Busbars
3. Install bolts and hardware ten places (hand-tight) to secure List 19 Expansion Busbars to Power/Distribution Bay busbars. 3/8-16 x 1-1/4" Bolt, 3/8" Belleville Lock Washer, Busbars
4. After bays are bolted together, torque 3/8" bolts (securing Expansion Busbars to Power/Distribution Bay and Distribution Only Bay) to 180 in-lbs.

Figure 4.18 Bolting Distribution Only Bay to PDSC (AC Input 'Power Distribution Service Cabinet')

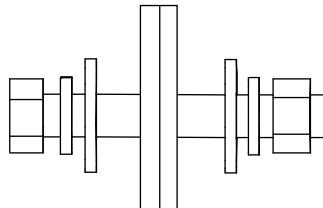


Bay/Cabinet Sides



Hardware Build-Up: (use ground washers in center tie points each side)
Bolt, Ground Washer, Bay/Cabinet Sides, Ground Washer, Nut

Bay/Cabinet Sides



Hardware Build-Up: (use in remaining connection points)
Bolt, Lock Washer, Flat Washer, Bay/Cabinet Sides, Flat Washer, Lock Washer, Nut

4.6 Installing Power/Distribution Bay to Power/Distribution Bay Negative and Positive Busbar Links



NOTE! Refer to the next procedure to connect the newer style bay to an existing older style bay.



NOTE! Apply electrical anti-oxidation compound to mating surfaces of busbars before connecting together.

Procedure

1. Refer to **Figure 4.19** or **Figure 4.20** and install the "Negative Busbar Link" between the "Negative Side" of one bay and the "Negative Side" of the adjacent bay. Use the supplied 3/8-16 x 1-1/2" bolts and hardware. Hardware build-up is: Bolt, Belleville Lock Washer, Belleville Lock Washer (concave side of Belleville lock washers face each other), Hardened Flat Washer. Torque to 180 in-lbs.
2. Refer to **Figure 4.19** or **Figure 4.20** and install the "Positive Busbar Link" between the "Positive Side" of one bay and the "Positive Side" of the adjacent bay. Use the supplied 3/8-16 x 1-1/2" bolts and hardware. Hardware build-up is: Bolt, Belleville Lock Washer, Belleville Lock Washer (concave side of Belleville lock washers face each other), Hardened Flat Washer. Torque to 180 in-lbs.
3. For bays with PDSCs, the busbar link cover shield is installed after all mounting and electrical connection procedures are completed.
4. Repeat these steps for each adjacent bay.

Figure 4.19 Installing Power/Distribution Bay to Power/Distribution Bay Negative and Positive Busbar Links (Lists 101 and 111)

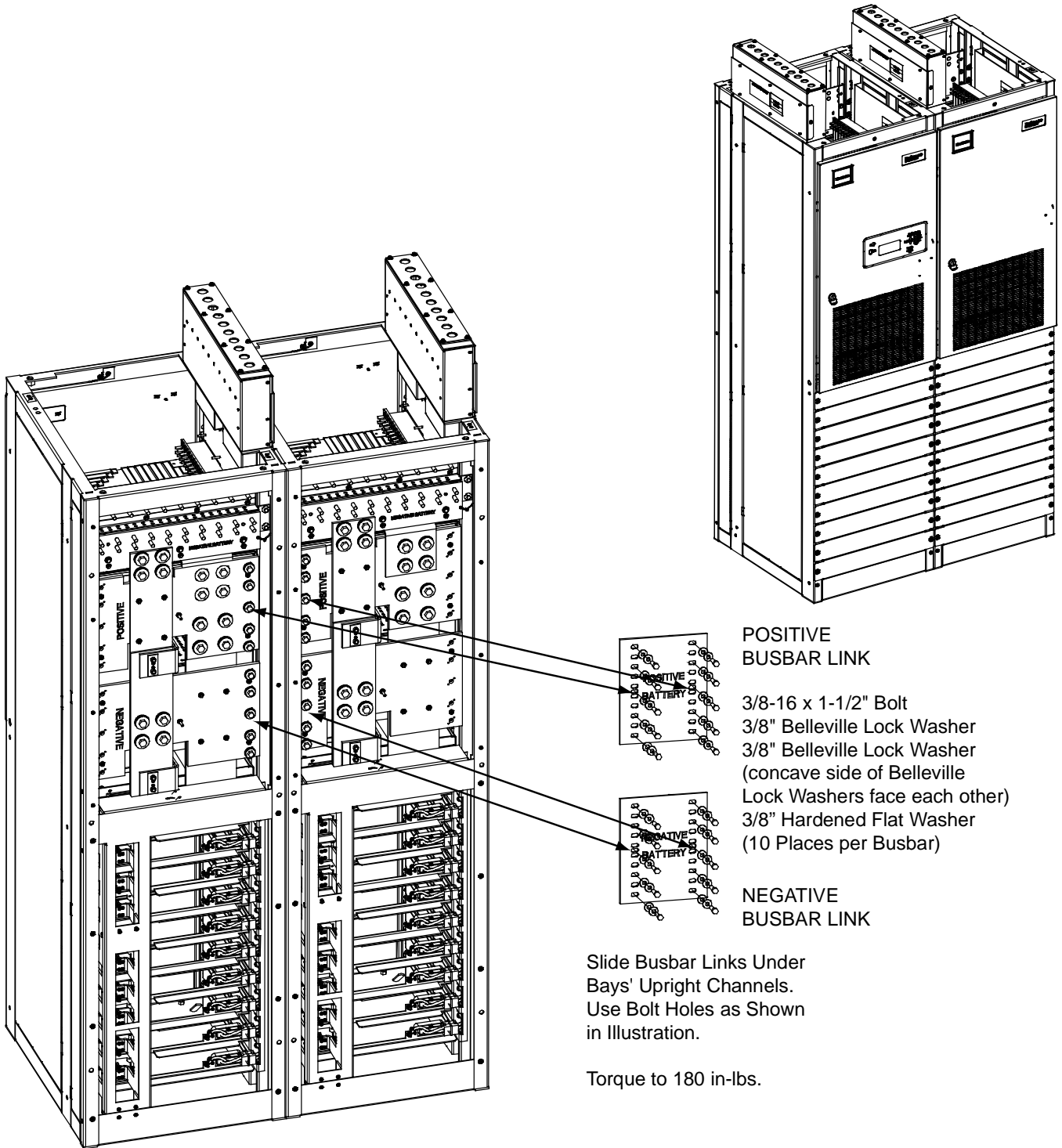
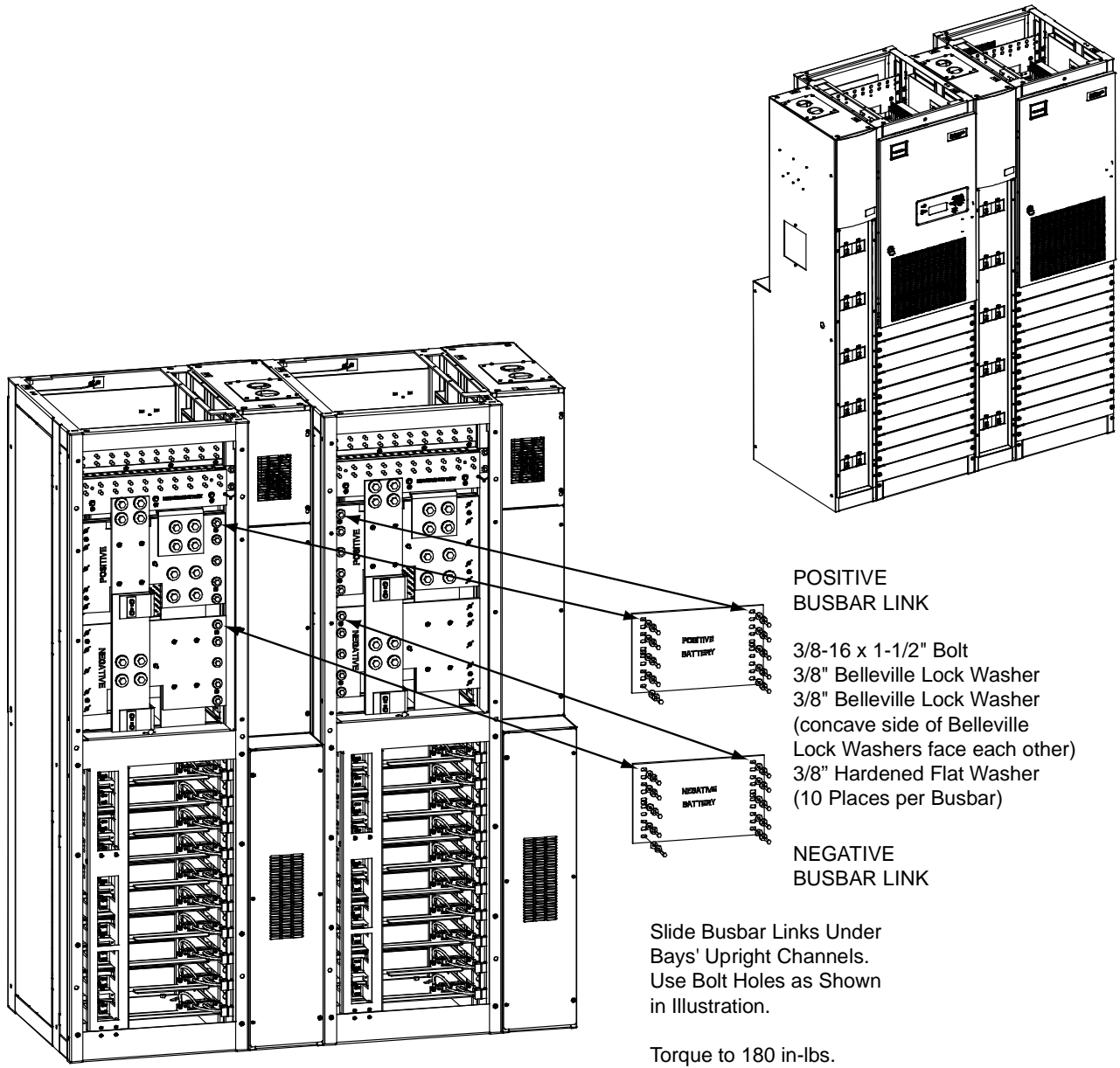


Figure 4.20 Installing Power/Distribution Bay to Power/Distribution Bay Negative and Positive Busbar Links (Lists 102 and 112, w/ List 130 or 131)



**POSITIVE
BUSBAR LINK**

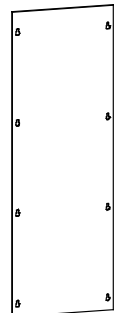
- 3/8-16 x 1-1/2" Bolt
- 3/8" Belleville Lock Washer
- 3/8" Belleville Lock Washer (concave side of Belleville Lock Washers face each other)
- 3/8" Hardened Flat Washer (10 Places per Busbar)

**NEGATIVE
BUSBAR LINK**

Slide Busbar Links Under Bays' Upright Channels. Use Bolt Holes as Shown in Illustration.

Torque to 180 in-lbs.

Busbar Link Cover Shield (installed after all mounting and electrical connection procedures are completed)



4.7 Installing Power/Distribution Bay to Power/Distribution Bay Negative and Positive Busbar Links (Newer Style Bay to an Existing Older Style Bay)

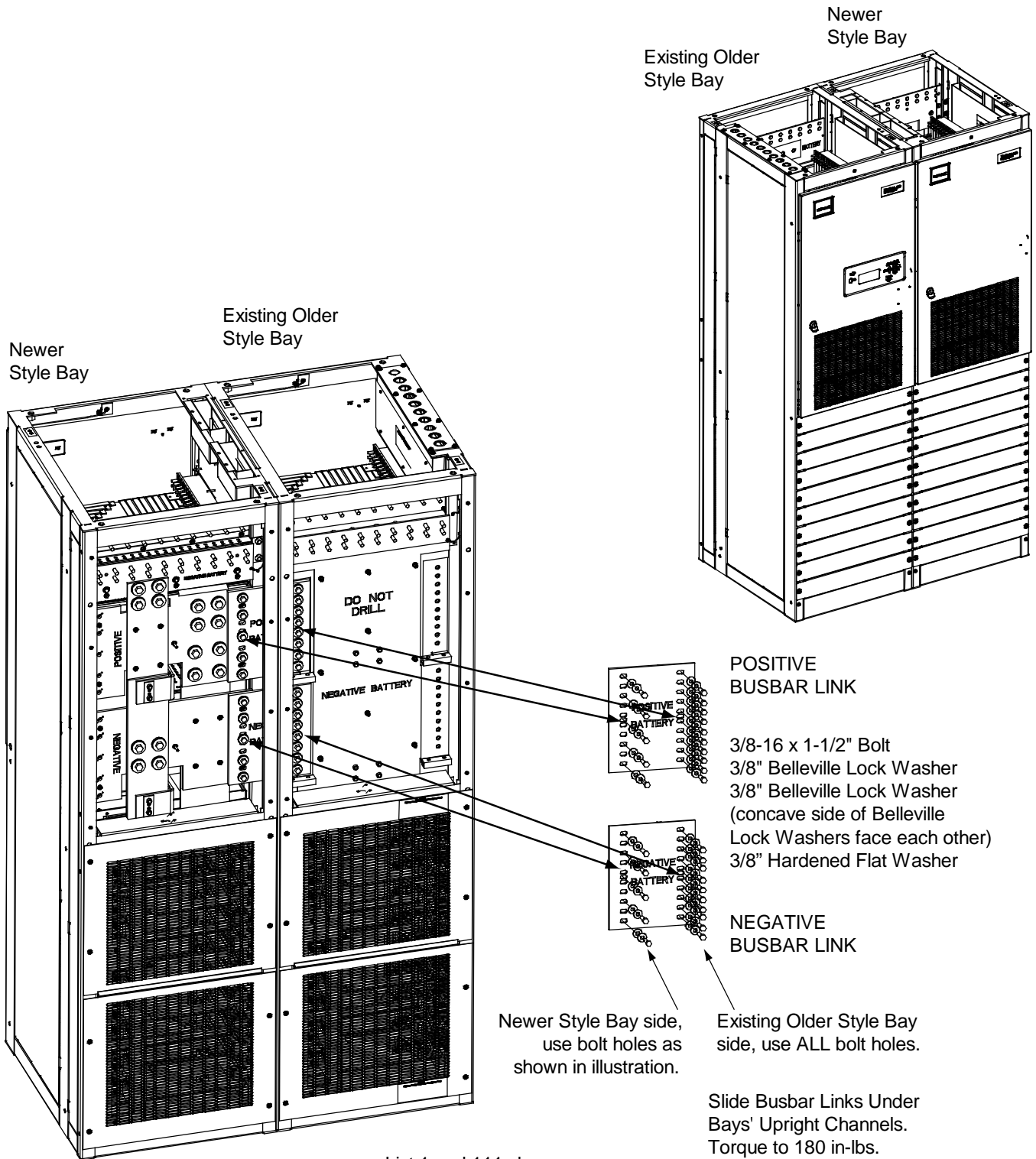


NOTE! Apply electrical anti-oxidation compound to mating surfaces of busbars before connecting together.

Procedure

1. Refer to **Figure 4.21** and install the "Negative Busbar Link" between the "Negative Side" of one bay and the "Negative Side" of the adjacent bay. Use the supplied 3/8-16 x 1-1/2" bolts and hardware. Hardware build-up is: Bolt, Belleville Lock Washer, Belleville Lock Washer (concave side of Belleville lock washers face each other), Hardened Flat Washer. Torque to 180 in-lbs.
2. Refer to **Figure 4.21** and install the "Positive Busbar Link" between the "Positive Side" of one bay and the "Positive Side" of the adjacent bay. Use the supplied 3/8-16 x 1-1/2" bolts and hardware. Hardware build-up is: Bolt, Belleville Lock Washer, Belleville Lock Washer (concave side of Belleville lock washers face each other), Hardened Flat Washer. Torque to 180 in-lbs.
3. For bays with PDSCs, the busbar link cover shield is installed after all mounting and electrical connection procedures are completed.
4. Repeat these steps for each adjacent bay.

Figure 4.21 Installing Power/Distribution Bay to Power/Distribution Bay Negative and Positive Busbar Links (Newer Style Bay Connected to an Existing Older Style Bay)



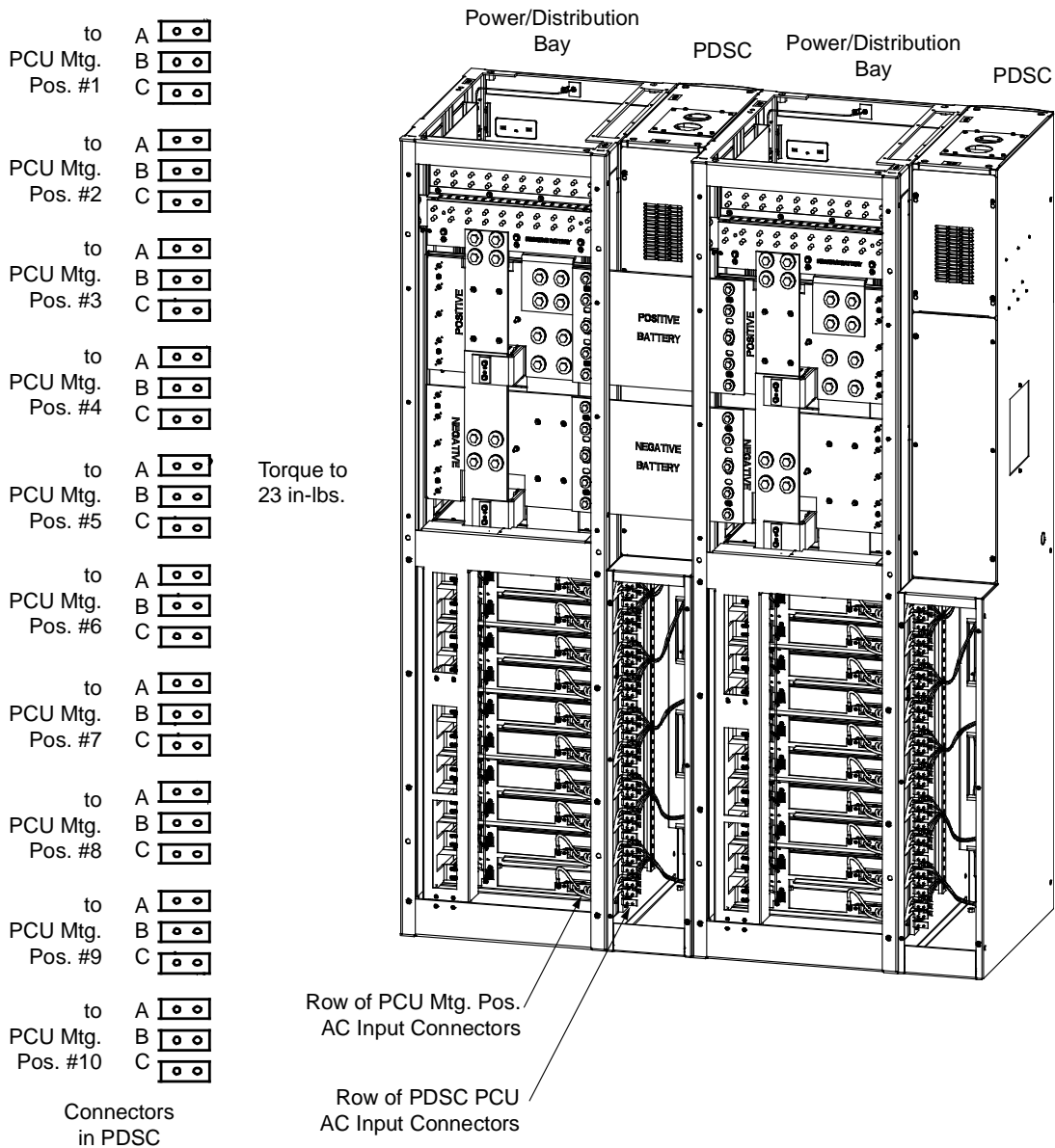
List 1 and 111 shown.
List 2 and 112 w/ List 30 or 31 similar.

4.8 Connecting Power/Distribution Bay Rectifier Mounting Position AC Input Connectors to PDSC (Lists 102 and 112 Only)

Procedure

1. Refer to **Figure 4.22**, and feed the wires from the rectifier mounting position AC input connectors located in a power/distribution bay through the side of the rectifier mounting position AC input cover and into the PDSC. Connect the wires to the appropriate connectors provided in the PDSC. Observe the labels (A, B, C). Torque each connection to 23 in-lbs.
2. Repeat this step for each bay.

Figure 4.22 Connecting Rectifier Mounting Position AC Input Connectors to PDSC (Lists 102 and 112 Only)



4.9 Installing Power/Distribution Bay External Top-Mount Horizontal Battery Input Busbar Assembly, P/N 554873 (if furnished)

Tools and Material Required to Install the Busbar Assembly

- a) 9/16" Wrench (for 3/8" Hardware)
- b) 15/16" Wrench (for 5/8" Hardware)
- c) Channel Locks
- d) Anti-Oxidation Compound
- e) Torque Wrench

Installation Procedure



DANGER! Before performing this procedure, ensure that the Power/Distribution Bay is COMPLETELY DISCONNECTED from all power sources.



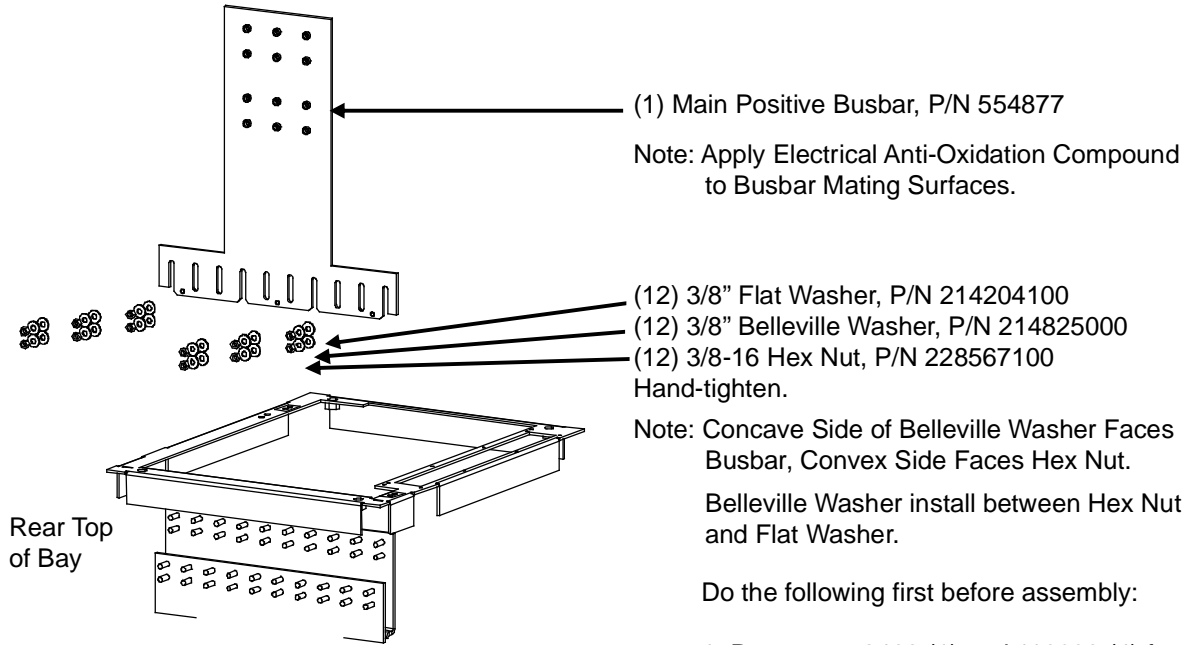
NOTE! Apply electrical anti-oxidation compound to mating surfaces of busbars before connecting together.

Assemble the busbar kit to the top of the bays as shown in **Figure 4.23** through **Figure 4.30**. Refer to **Figure 4.30** for an assembled view.

Figure 4.23 Power/Distribution Bay External Top-Mount Horizontal Busbar Assembly (P/N 554873) Assembly Procedure Step 1

STEP 1

Install “Main Positive Busbar” onto Bay’s Positive Busbar. Hand-tighten hardware.



Do the following first before assembly:

1. Remove 552402 (1) and 116638 (4) from Bay.
2. Mount 554880 to the 554877 with 116638 (3).

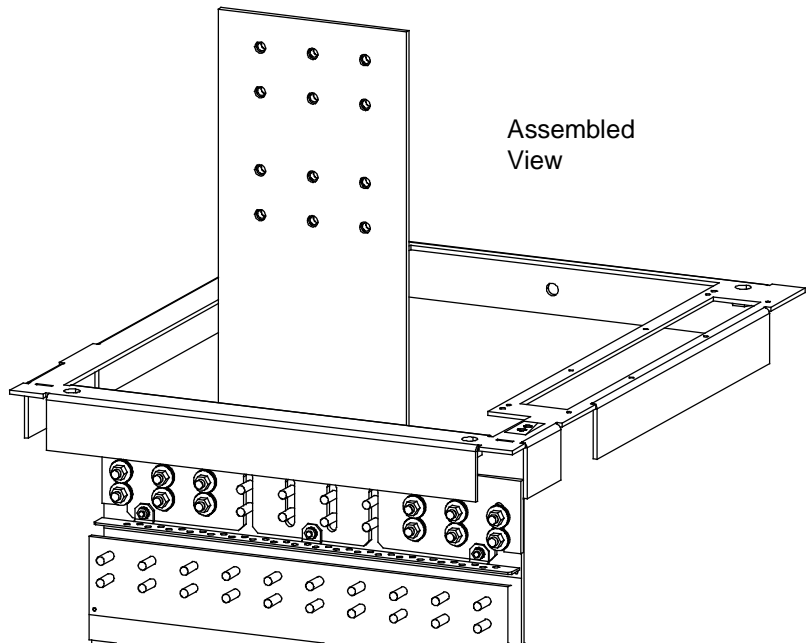


Figure 4.24 Power/Distribution Bay External Top-Mount Horizontal Busbar Assembly (P/N 554873) Assembly Procedure Step 2

STEP 2

Install “Support Bar” and “Related Hardware” onto Top of Bay.

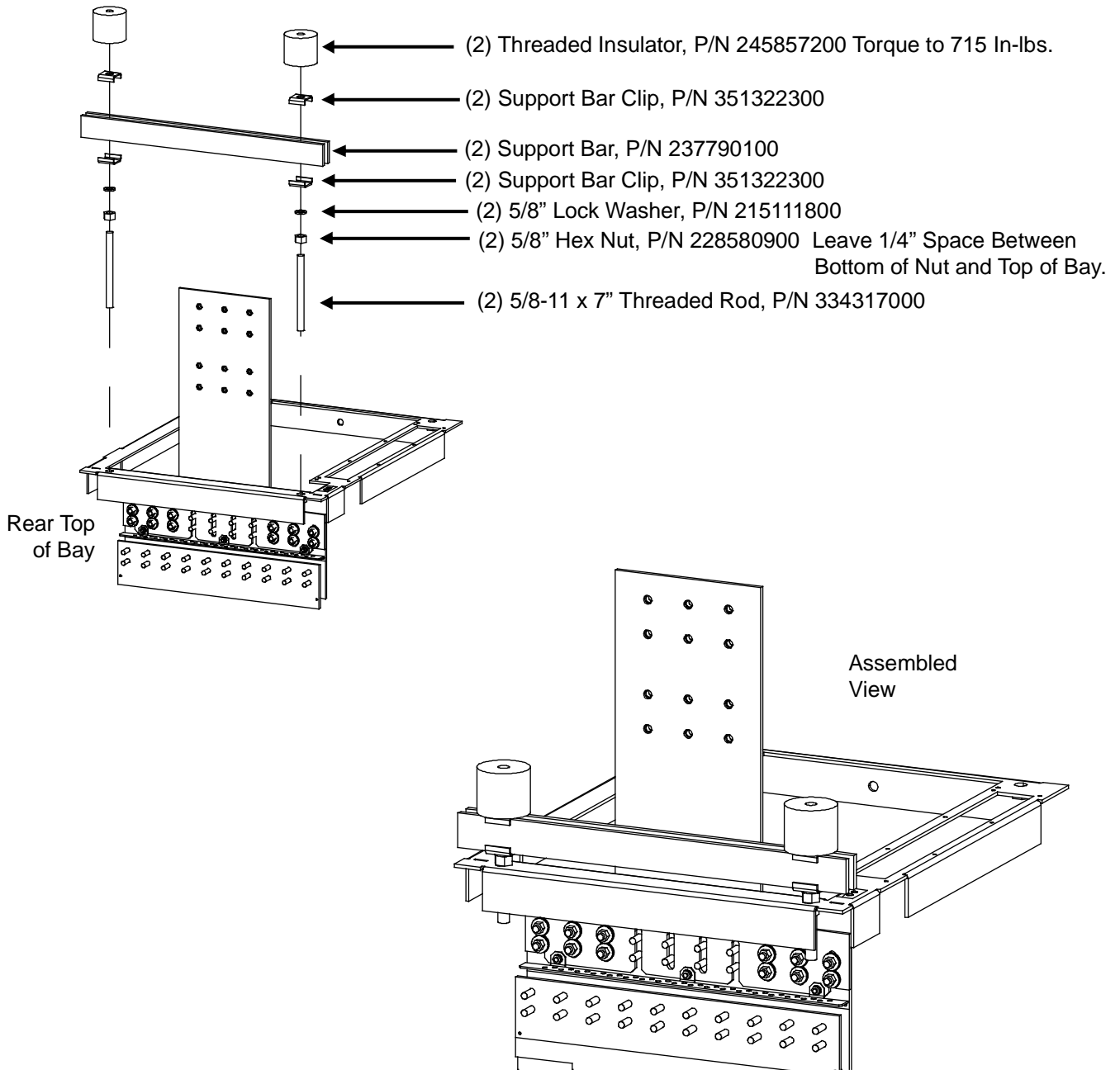


Figure 4.25 Power/Distribution Bay External Top-Mount Horizontal Busbar Assembly (P/N 554873) Assembly Procedure Step 3

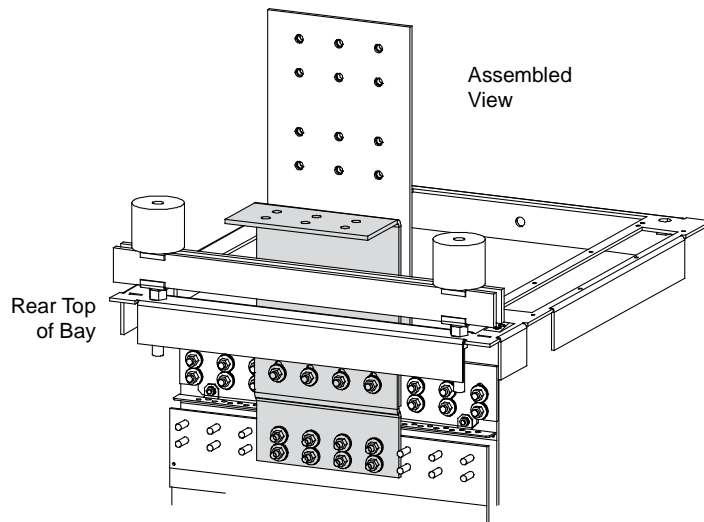
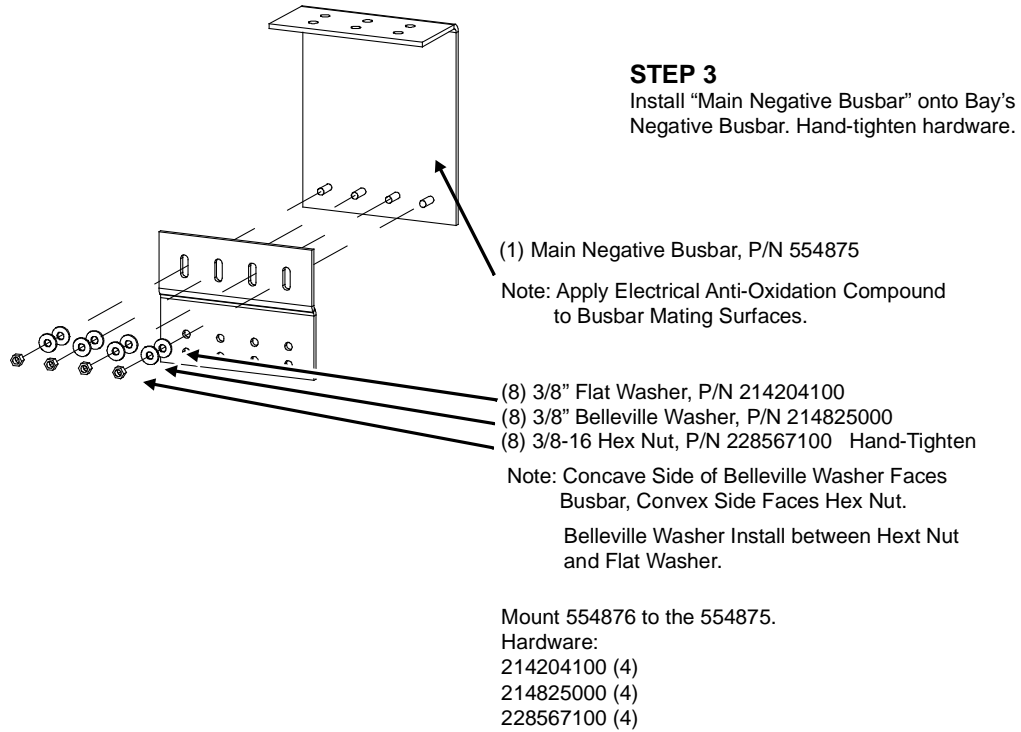


Figure 4.26 Power/Distribution Bay External Top-Mount Horizontal Busbar Assembly (P/N 554873) Assembly Procedure Step 4

STEP 4

Install “Horizontal Landing Negative Busbar” onto “Main Negative Busbar”.

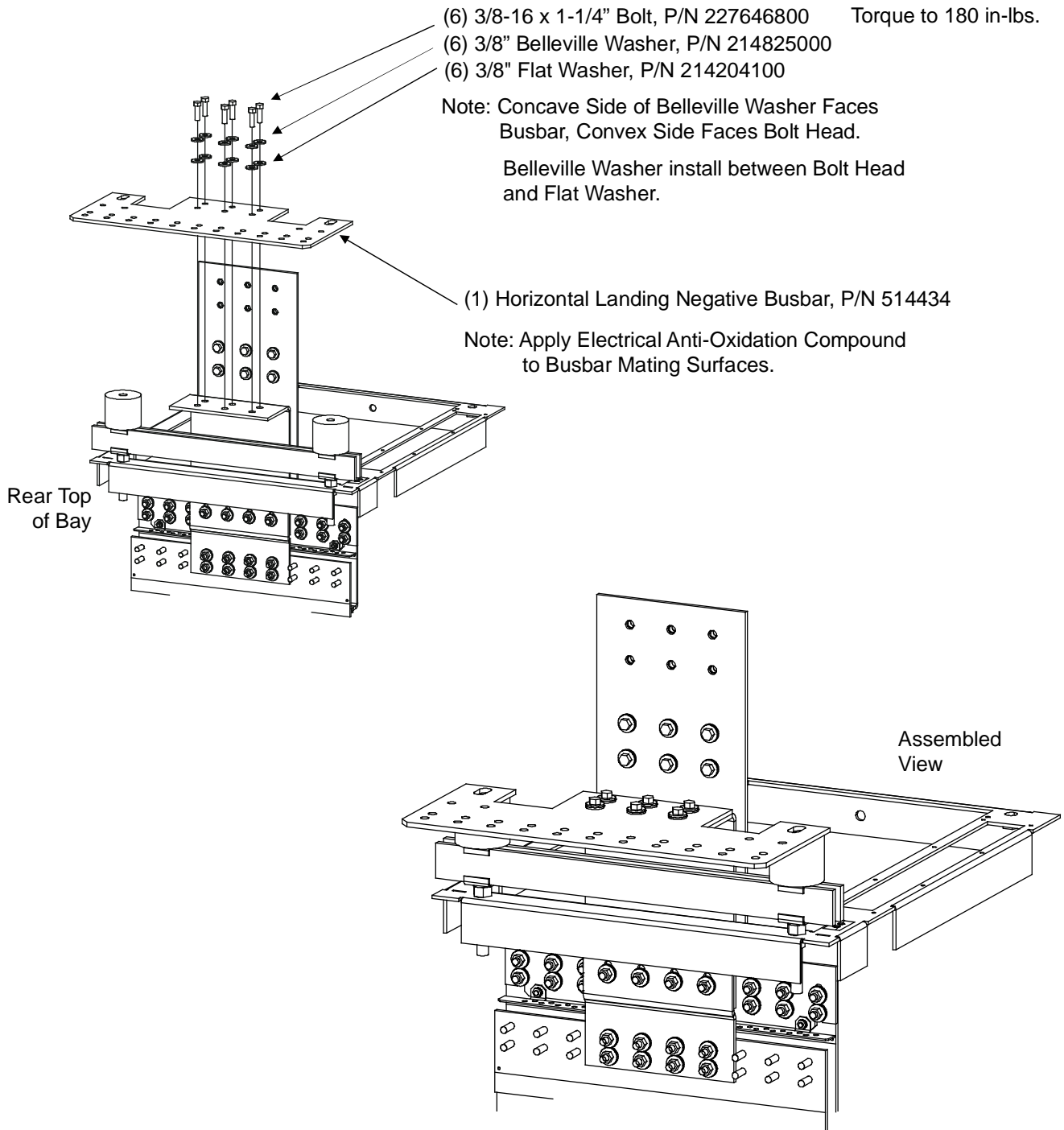


Figure 4.27 Power/Distribution Bay External Top-Mount Horizontal Busbar Assembly (P/N 554873) Assembly Procedure Step 5

STEP 5

Install "Threaded Insulators" onto "Horizontal Landing Negative Busbar".

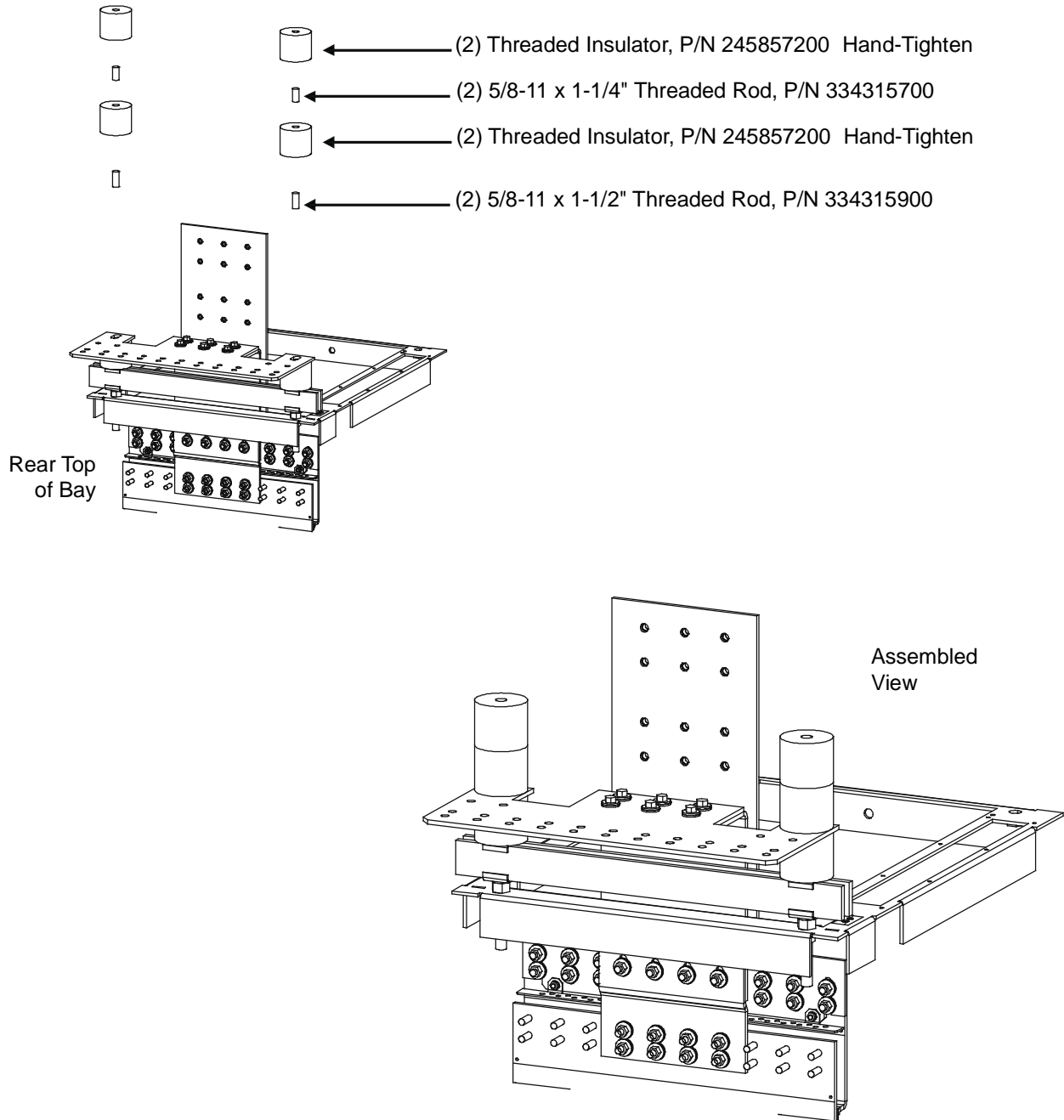


Figure 4.28 Power/Distribution Bay External Top-Mount Horizontal Busbar Assembly (P/N 554873) Assembly Procedure Step 6

STEP 6

Install "Horizontal Landing Positive Busbar" onto "Main Positive Busbar".

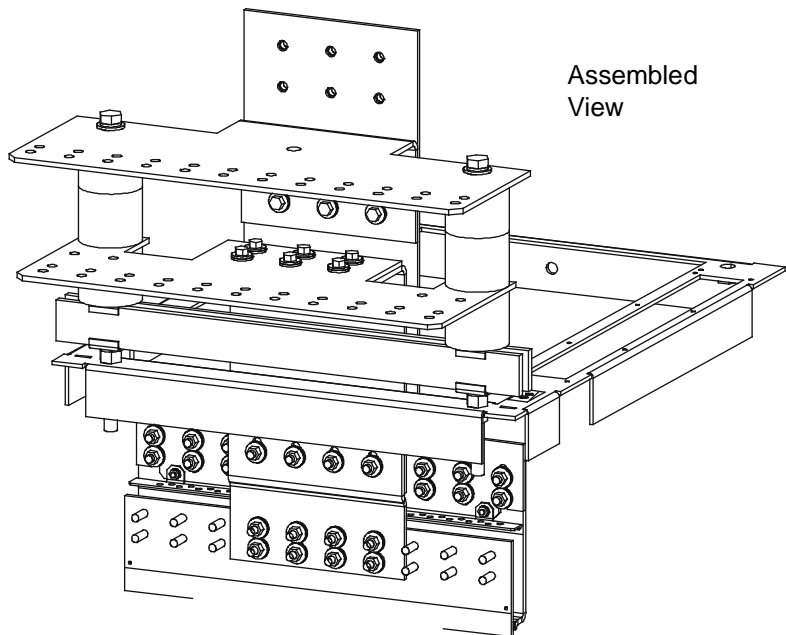
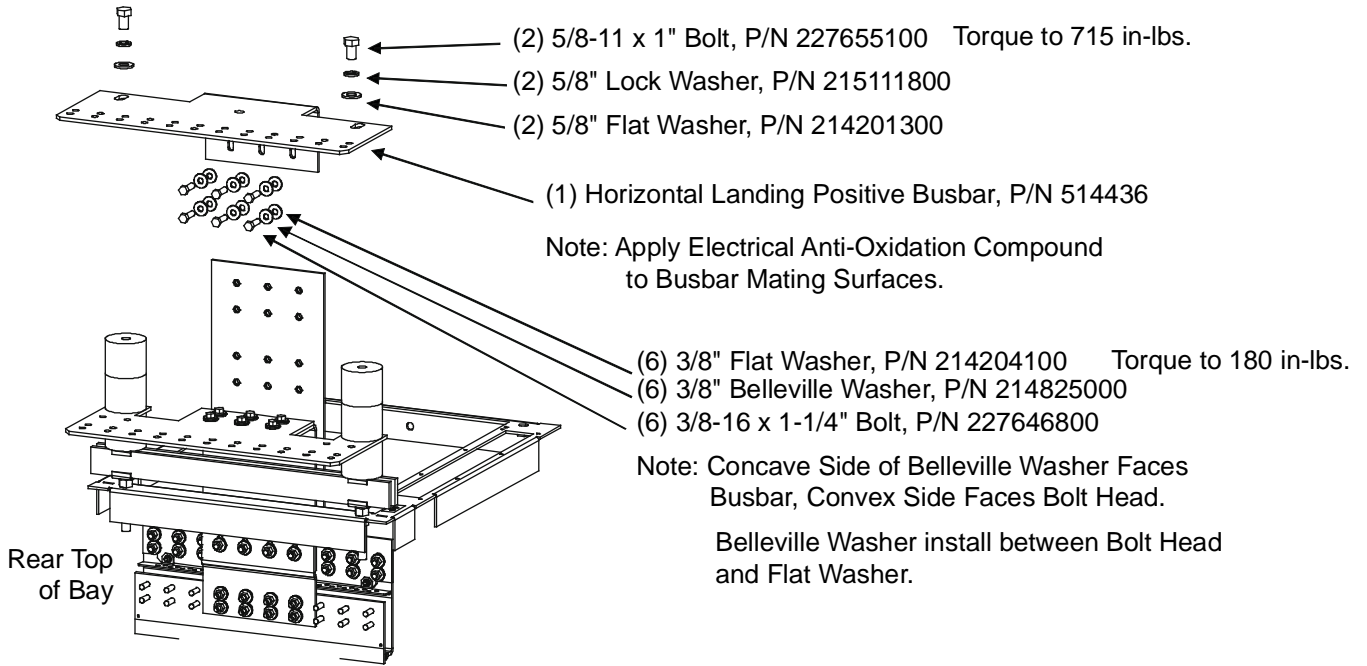
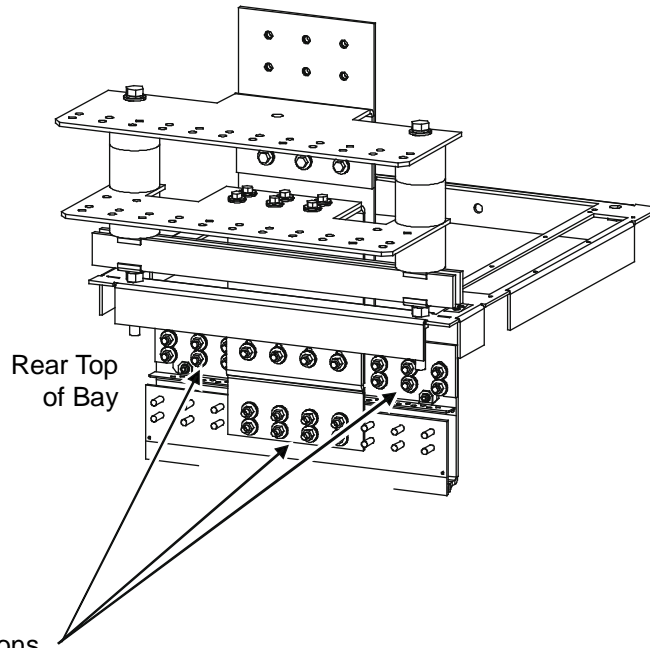


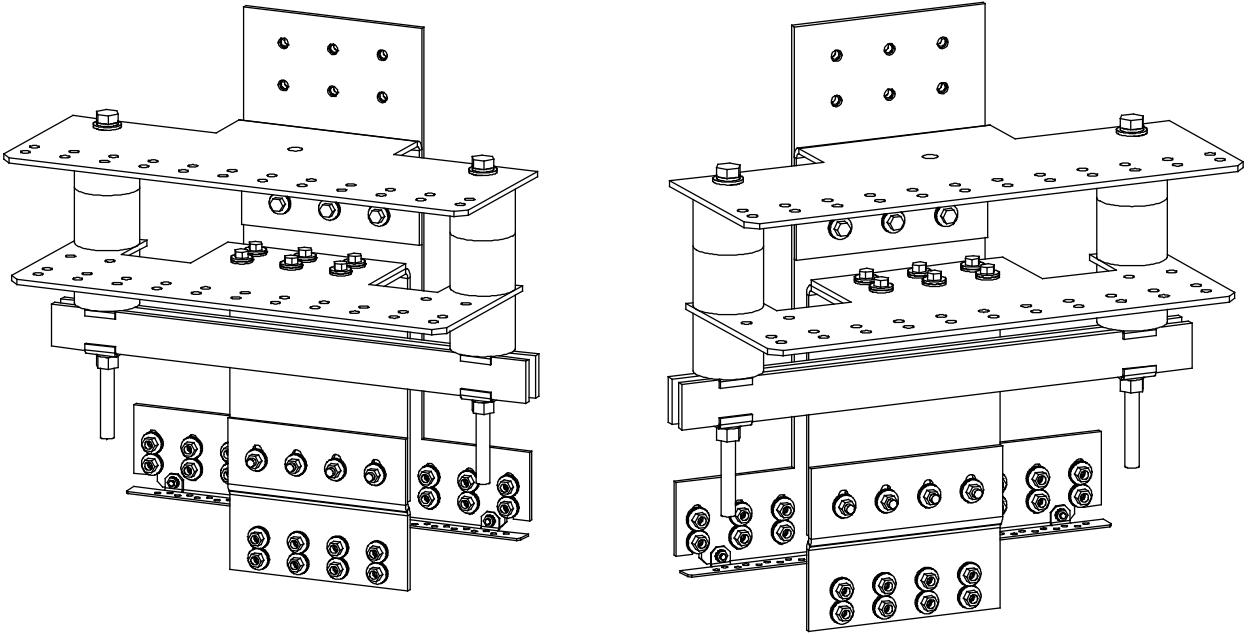
Figure 4.29 Power/Distribution Bay External Top-Mount Horizontal Busbar Assembly (P/N 554873) Assembly Procedure Step 7

STEP 7
Final Torque

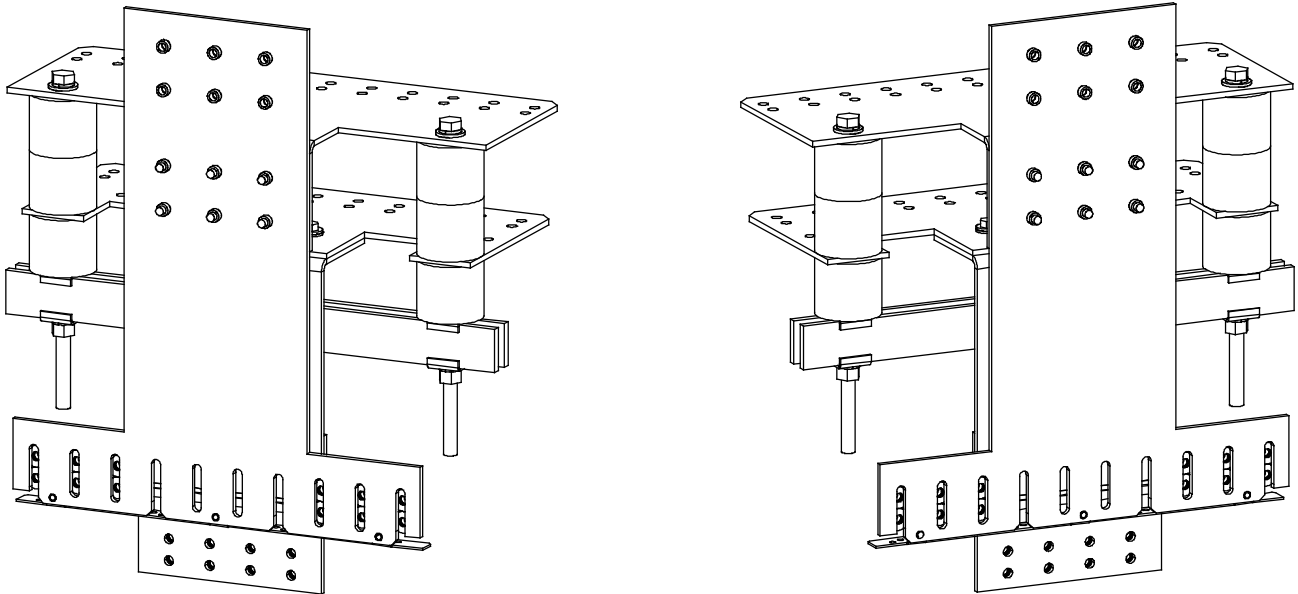


Torque these connections to 180 in-lbs (20 places).

Figure 4.30 Power/Distribution Bay External Top-Mount Horizontal Busbar Assembly (P/N 554873) Assembled Views



Assembled View from Rear of Bay



Assembled View from Front of Bay

4.10 Installing Optional Power/Distribution Bay Busbar Shield Kit, P/N 528482 (if furnished)

Tools and Material Required to Install the Busbar Assembly

- a) 9/16" Wrench (for 3/8" Hardware)
- b) Torque Wrench

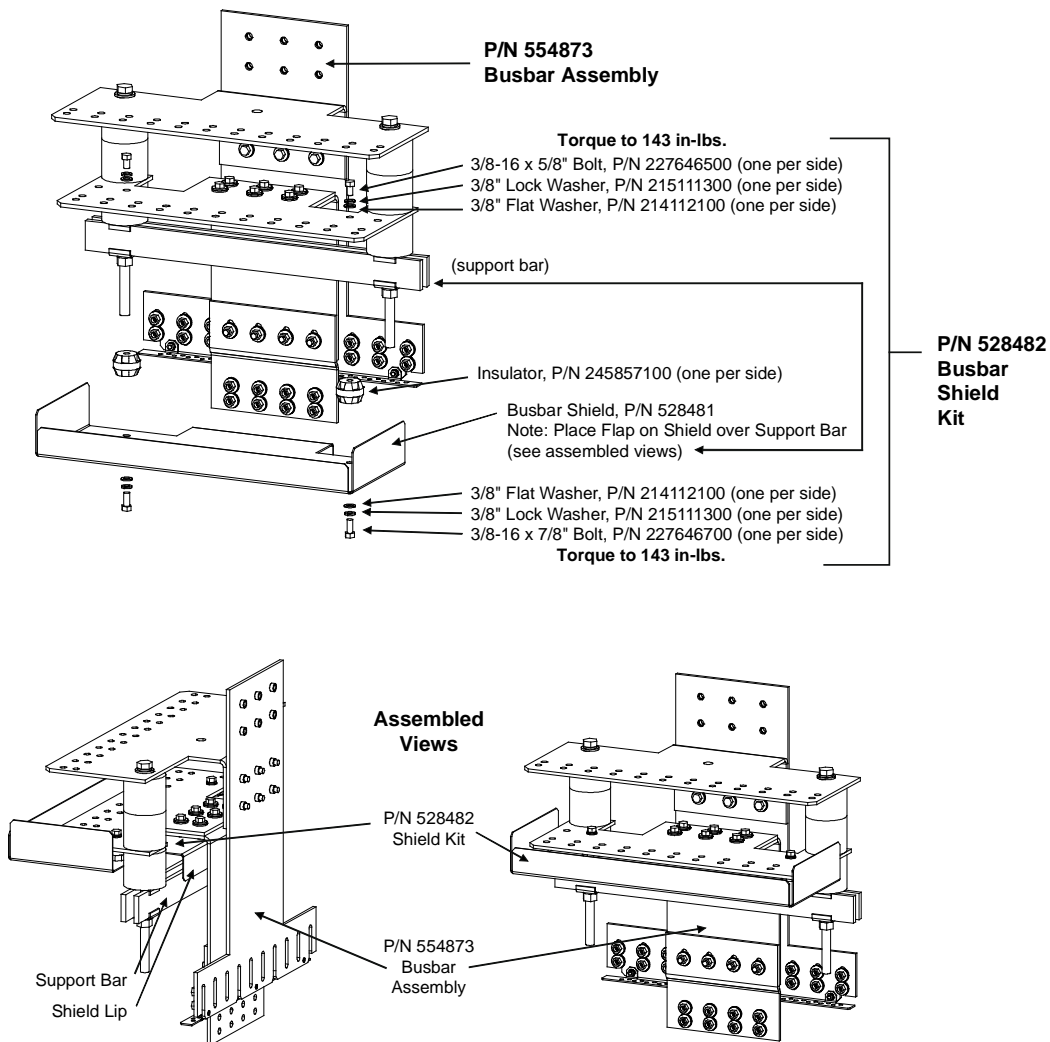
Installation Procedure



DANGER! Before performing this procedure, ensure that the power/distribution bay is COMPLETELY DISCONNECTED from all power sources.

1. Assemble the "Busbar Shield Kit, P/N 528482" to each "External Top-Mount Horizontal Battery Input Busbar Assembly, P/N 554873" as shown in **Figure 4.31**.

Figure 4.31 Optional Power/Distribution Bay Busbar Shield Kit (P/N 528482)



4.11 Installing Power/Distribution Bay External Top-Mount Ground (Load Return) Busbar Assembly; P/N 514688, 514689, 514690, or 514691 (if furnished)

Tools and Material Required to Install the Busbar Assembly

- a) 3/8" Wrench (for #10 Hardware)
- b) 7/16" Wrench (for 1/4" Hardware)
- c) 9/16" Wrench (for 3/8" Hardware)
- d) 15/16" Wrench (for 5/8" Hardware)
- e) Channel Locks
- f) Cross-Blade Screwdriver
- g) Anti-Oxidation Compound
- h) Torque Wrench

Installation Procedure for P/N 514688 and 514689



DANGER! Before performing this procedure, ensure that the power/distribution bay is COMPLETELY DISCONNECTED from all power sources.



NOTE! Apply electrical anti-oxidation compound to mating surfaces of busbars before connecting together.

1. Assemble the Busbar Kit to the top of the bays as shown in **Figure 4.32** through **Figure 4.37**. Refer to **Figure 4.38** and **Figure 4.39** for assembled views. Note that these busbar kits require "External Top-Mount Horizontal Battery Input Busbar Assembly", P/N 554873. These busbar kits attach to the P/N 554873 busbar kit.

IF YOU ARE ALSO INSTALLING "LOAD RETURN LUG EXTENSION BUSBAR ASSEMBLY" P/N 514543, DO NOT PERFORM STEP 3 (Installing Cover Mounting Standoffs) AND STEP 4 (Installing Covers) OF THIS PROCEDURE.

Figure 4.32 Power/Distribution Bay External Top-Mount Ground (Load Return) Busbar Assembly (P/N 514688 or 514689)
Assembly Procedure Step 1

STEP 1
Install "Threaded Insulators".

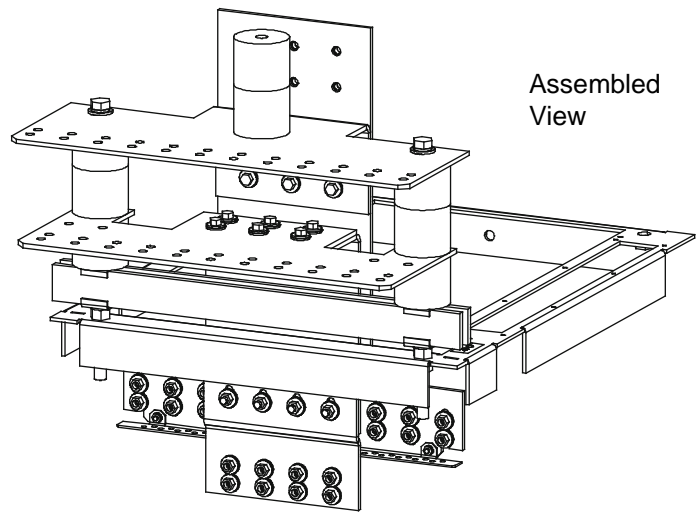
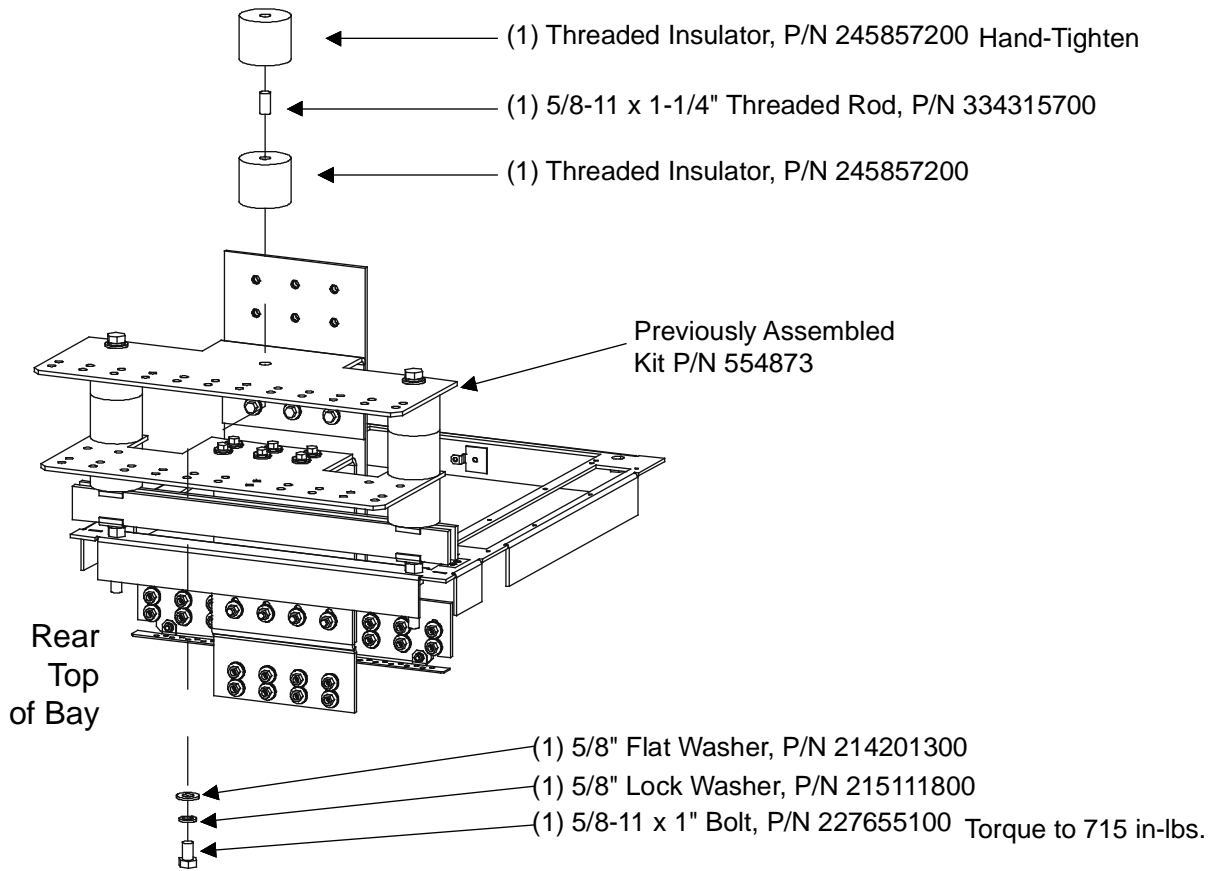


Figure 4.33 Power/Distribution Bay External Top-Mount Ground (Load Return) Busbar Assembly (P/N 514688 or 514689) Assembly Procedure Step 2A

STEP 2A
Install "Busbars".
(see Step 2B for Bolt Hole Identification)
(see Step 2C for Assembled View)

* Use "Spacer Busbars" or "Spacer Insulators" on end bays or stand-alone bays. For multiple bays, 'sandwich' busbars of adjacent "Busbar Assemblies" together.

Note: Apply Electrical Anti-Oxidation Compound to all Busbar Mating Surfaces.

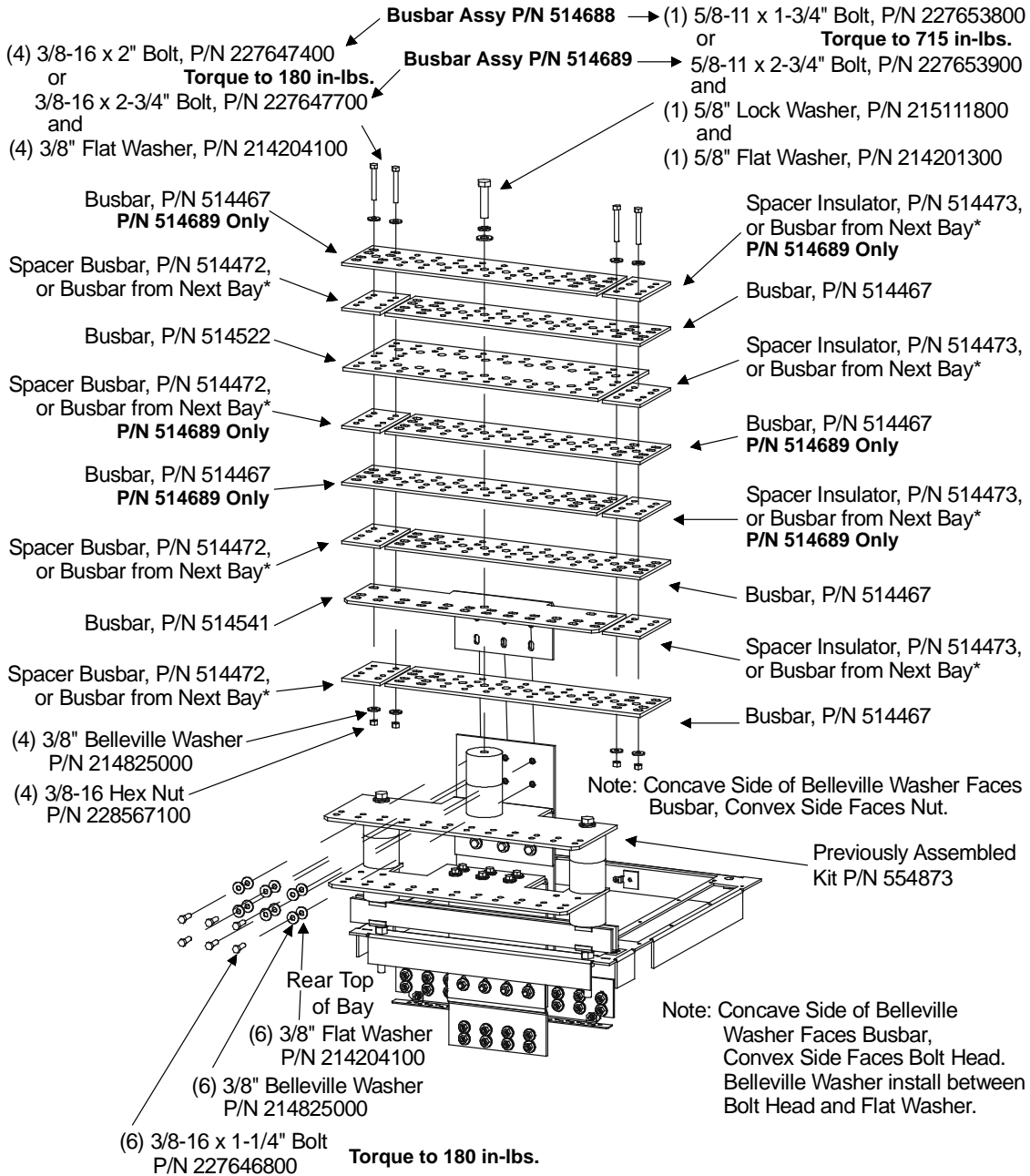
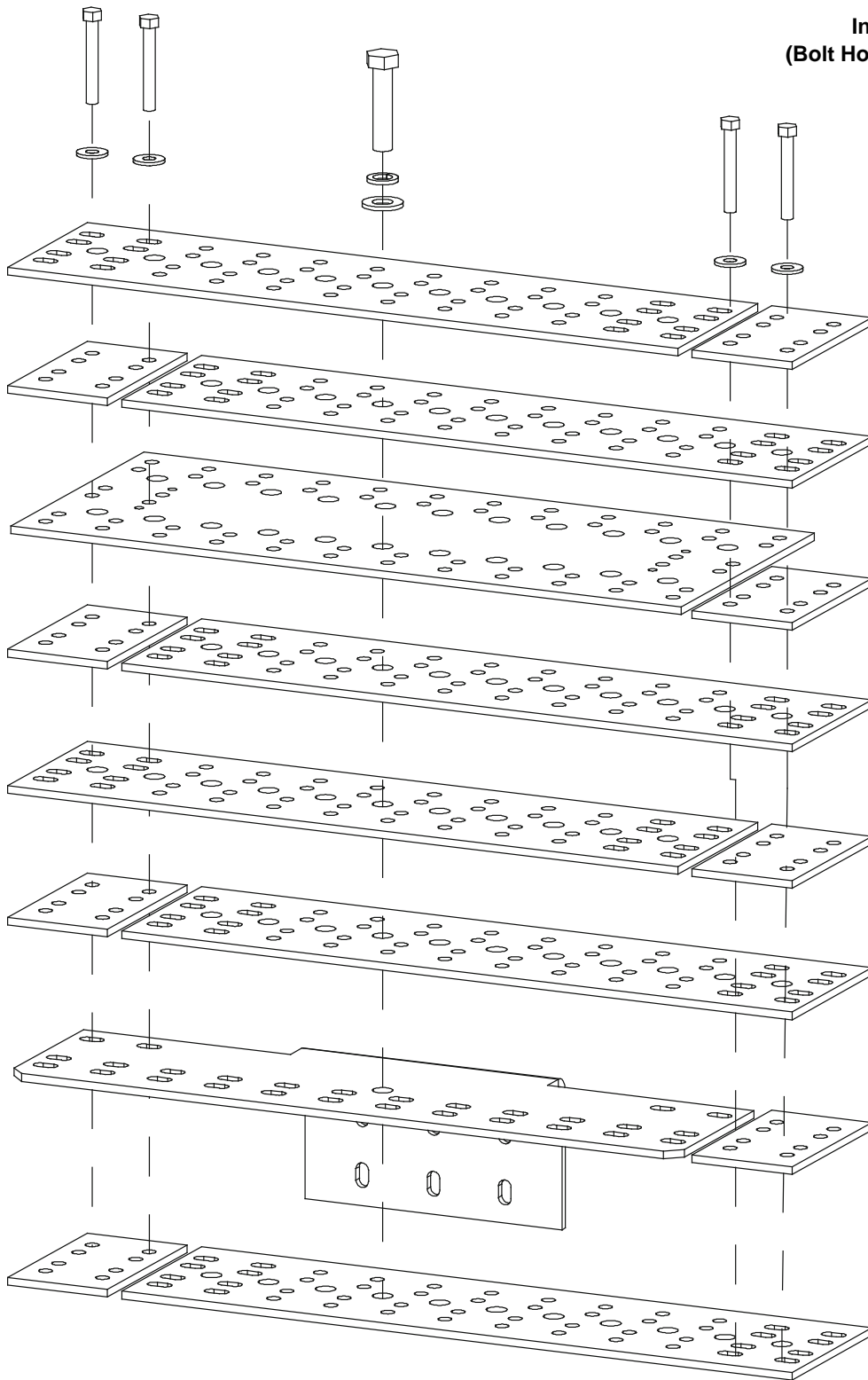
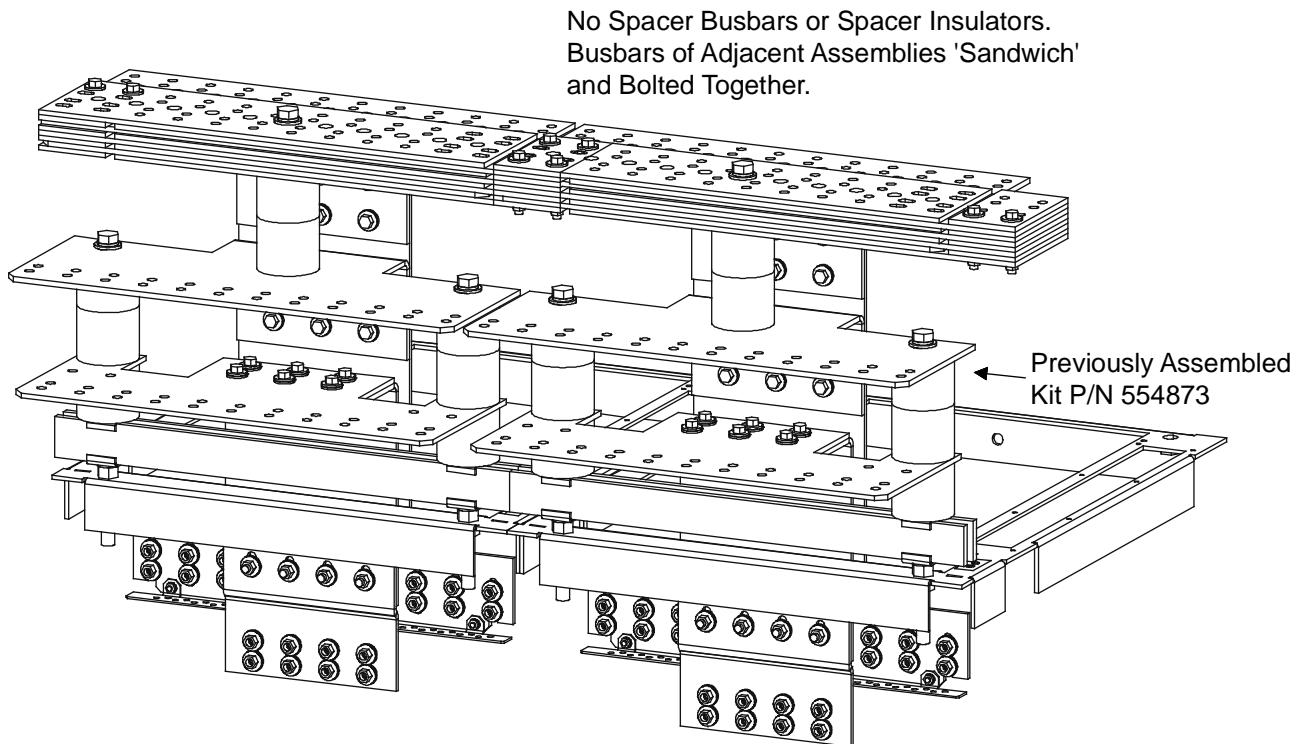
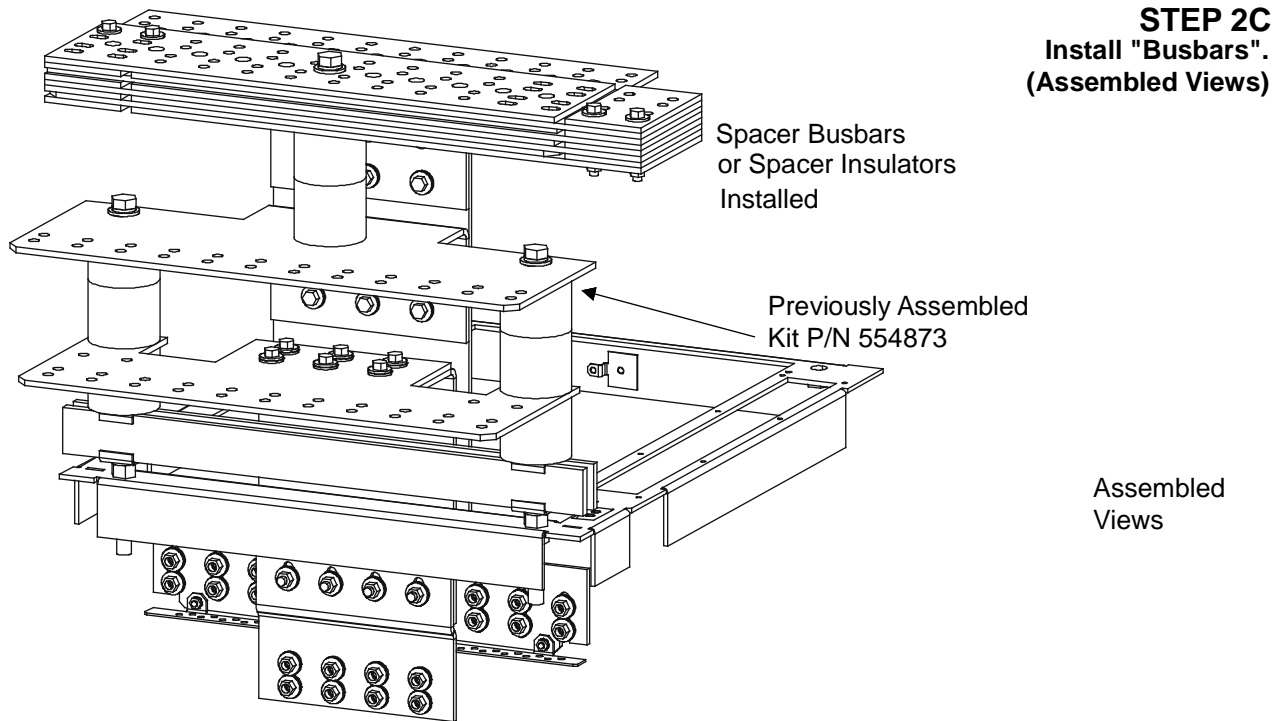


Figure 4.34 Power/Distribution Bay External Top-Mount Ground (Load Return) Busbar Assembly (P/N 514688 or 514689)
Assembly Procedure Step 2B

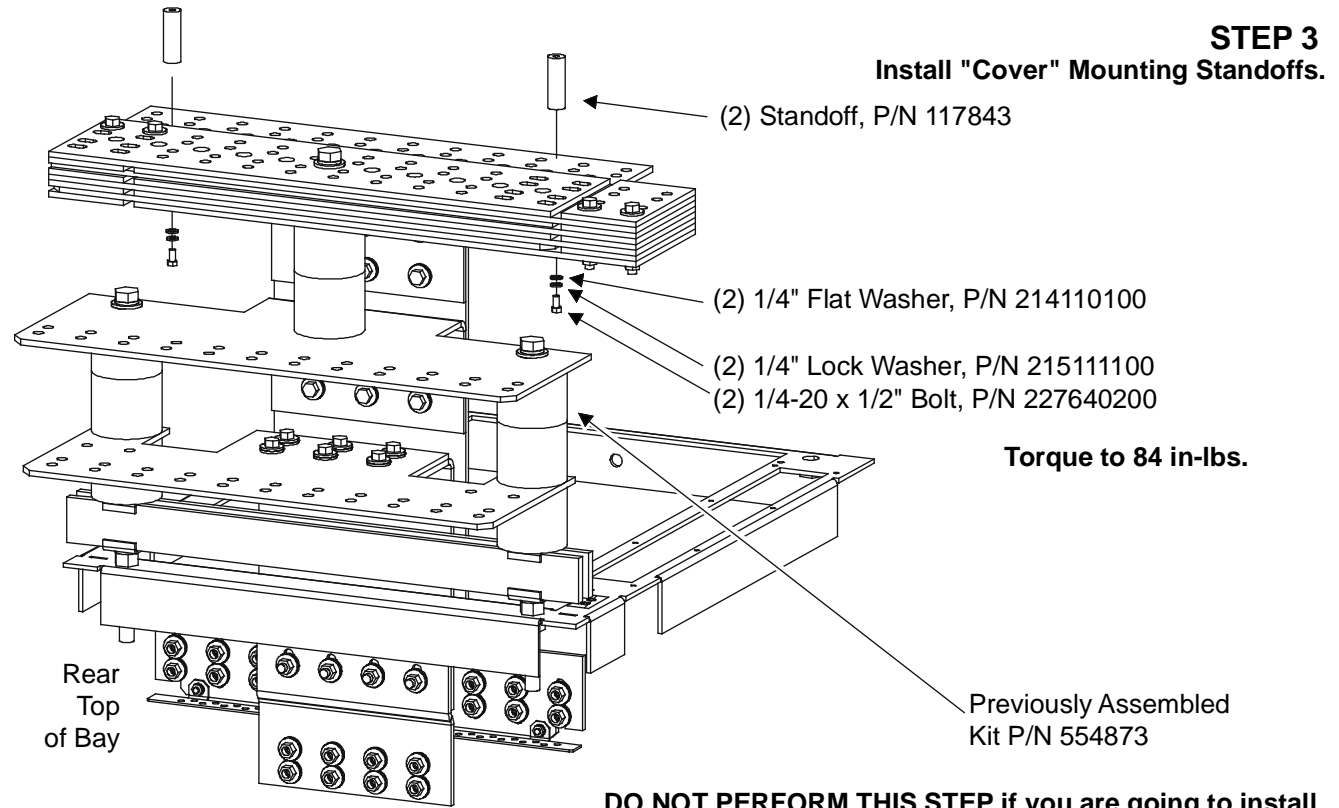
STEP 2B
Install "Busbars".
(Bolt Hole Identification)



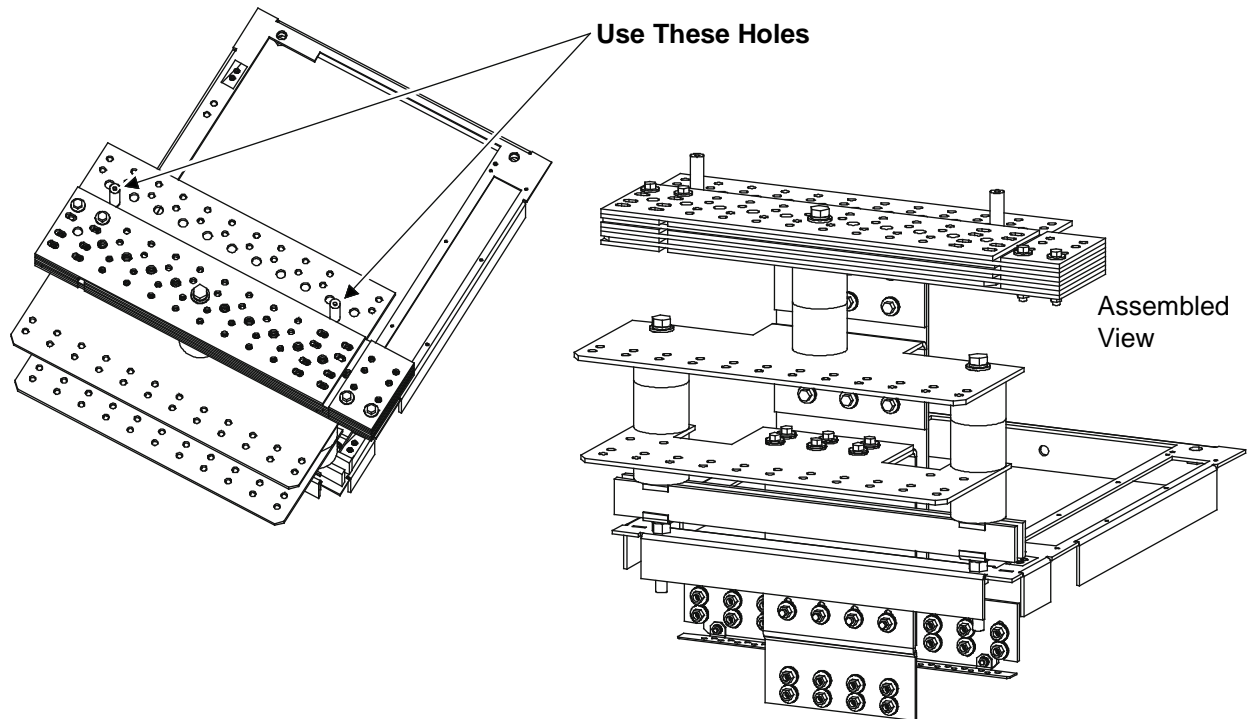
**Figure 4.35 Power/Distribution Bay External Top-Mount Ground (Load Return) Busbar Assembly (P/N 514688 or 514689)
Assembly Procedure Step 2C**



**Figure 4.36 Power/Distribution Bay External Top-Mount Ground (Load Return) Busbar Assembly (P/N 514688 or 514689)
Assembly Procedure Step 3**



DO NOT PERFORM THIS STEP if you are going to install "Load Return Lug Extension Busbar Assembly" P/N 514543



**Figure 4.37 Power/Distribution Bay External Top-Mount Ground (Load Return) Busbar Assembly (P/N 514688 or 514689)
Assembly Procedure Step 4**

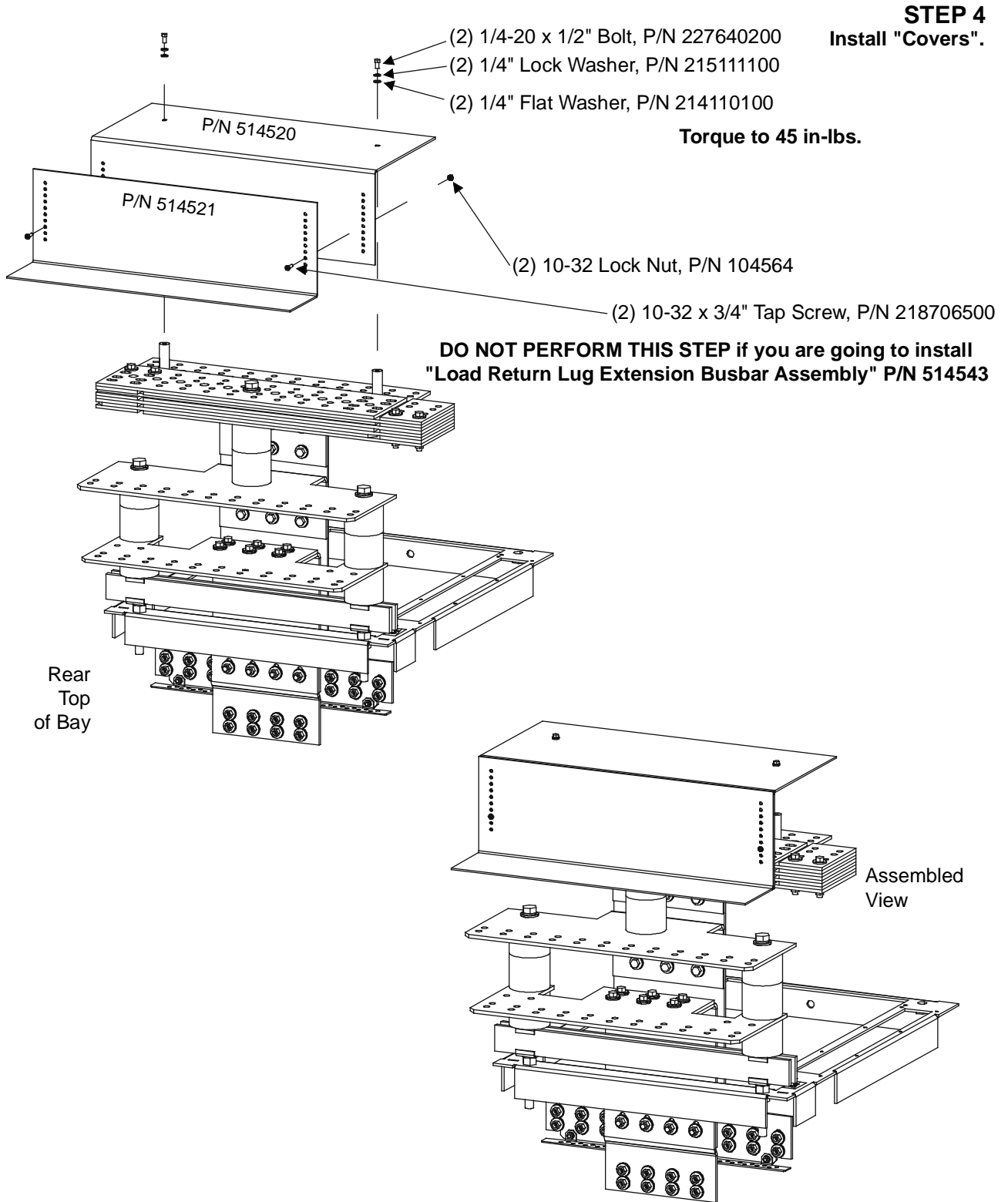
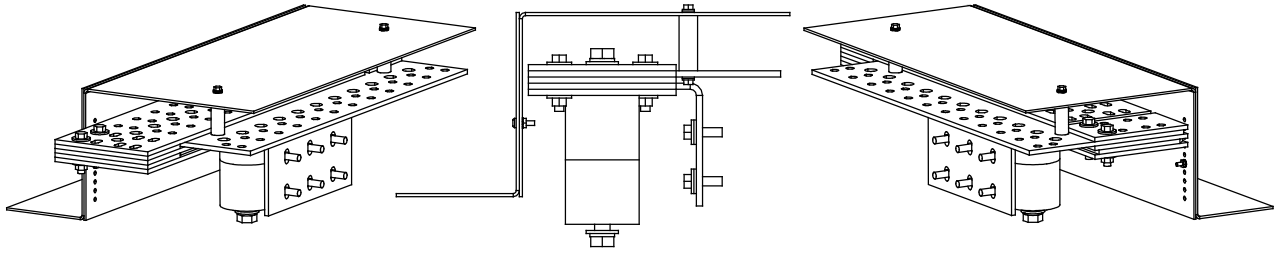
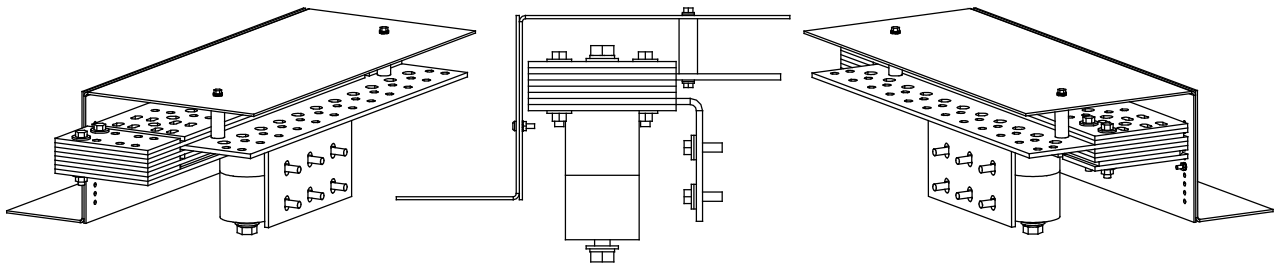


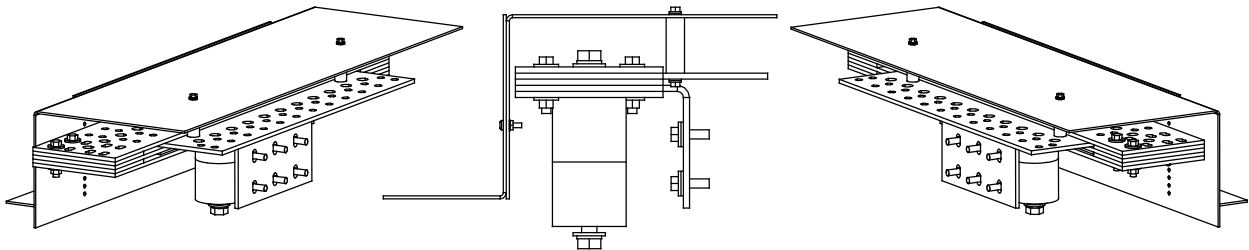
Figure 4.38 Power/Distribution Bay External Top-Mount Ground (Load Return) Busbar Assembly (P/N 514688, 514689, 514690, and 514691) Assembled Views



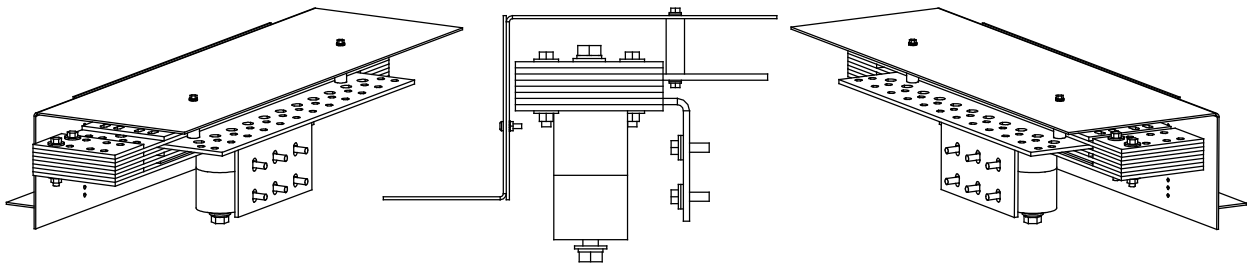
Assembled Views P/N 514688



Assembled Views P/N 514689

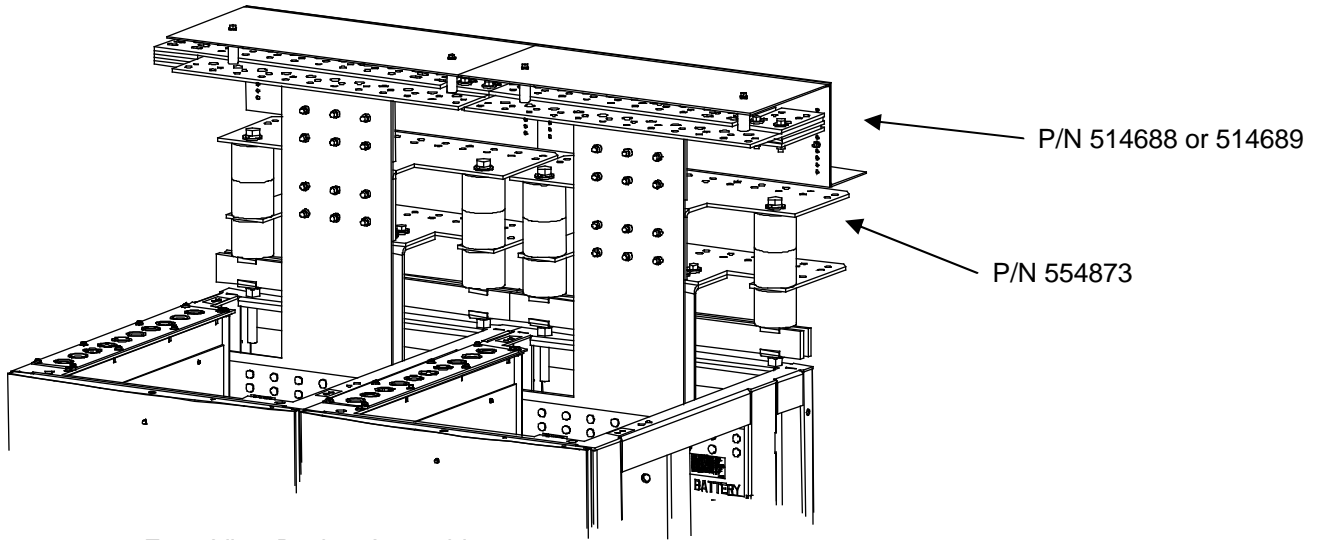


Assembled Views P/N 514690

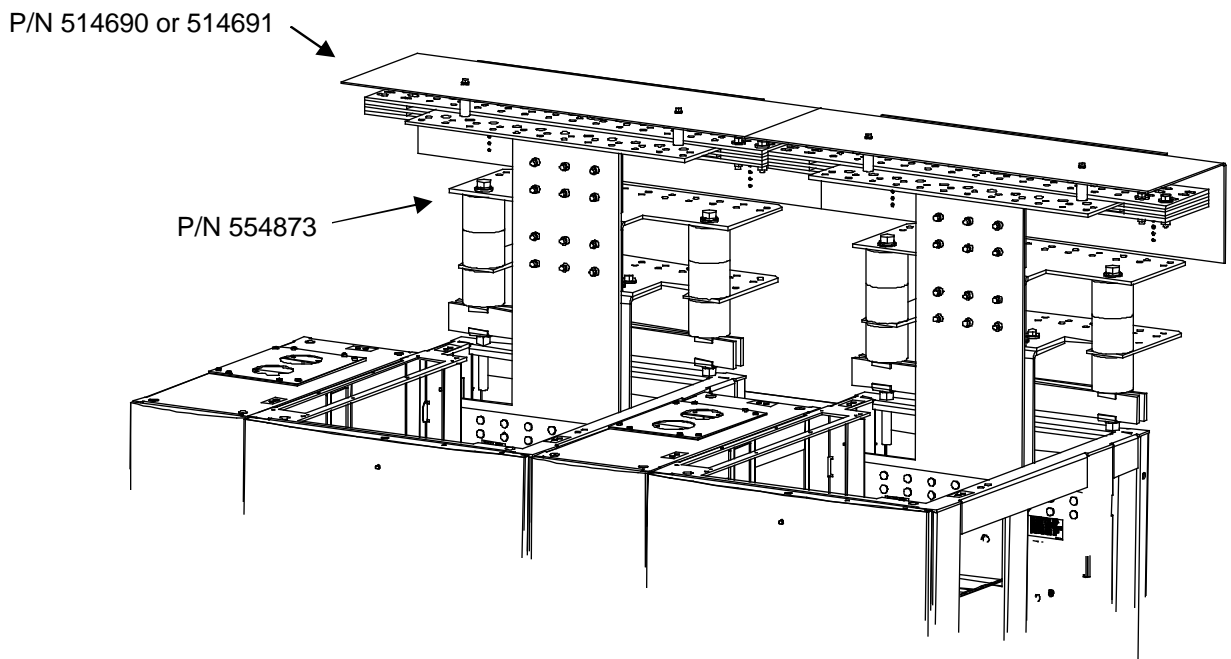


Assembled Views P/N 514691

Figure 4.39 Power/Distribution Bay External Top-Mount Ground (Load Return) Busbar Assembly (P/N 514688, 514689, 514690, and 514691) Assembled on Top of Bays



Front View Busbar Assembly
Assembled on Top of Bays
(List 101 and 111 Bays)



Installation Procedure for P/N 514690 and 514691



DANGER! Before performing this procedure, ensure that the power/distribution bay is COMPLETELY DISCONNECTED from all power sources.



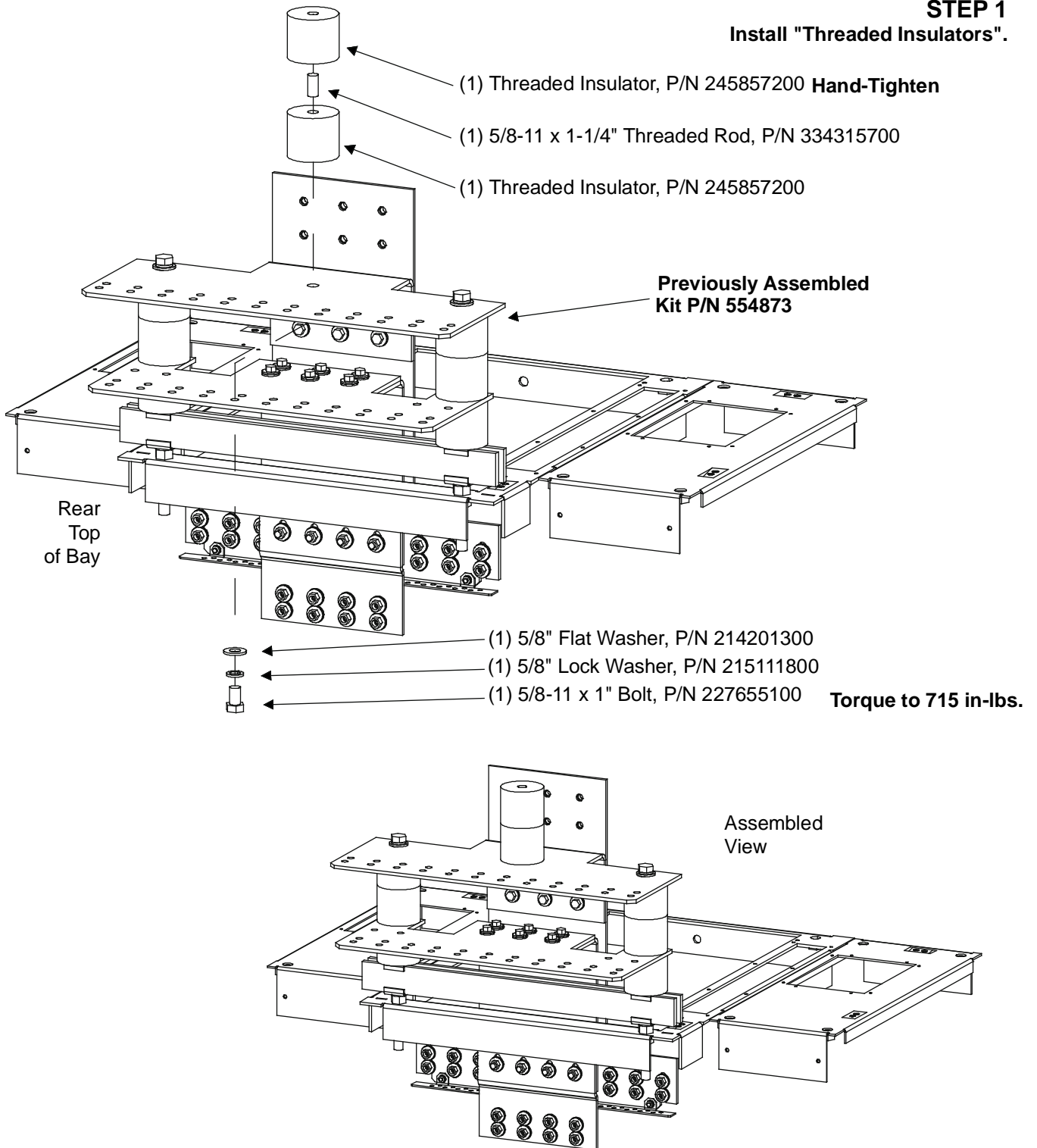
NOTE! *Apply electrical anti-oxidation compound to mating surfaces of busbars before connecting together.*

1. Assemble the busbar kit to the top of the bays as shown in **Figure 4.40** through **Figure 4.45**. Refer to **Figure 4.44** and **Figure 4.45** for assembled views. Note that these busbar kits require "External Top-Mount Horizontal Battery Input Busbar Assembly", P/N 554873. These busbar kits attach to the P/N 554873 busbar kit.

**Figure 4.40 Power/Distribution Bay External Top-Mount Ground (Load Return) Busbar Assembly (P/N 514690 or 514691)
Assembly Procedure Step 1**

STEP 1

Install "Threaded Insulators".

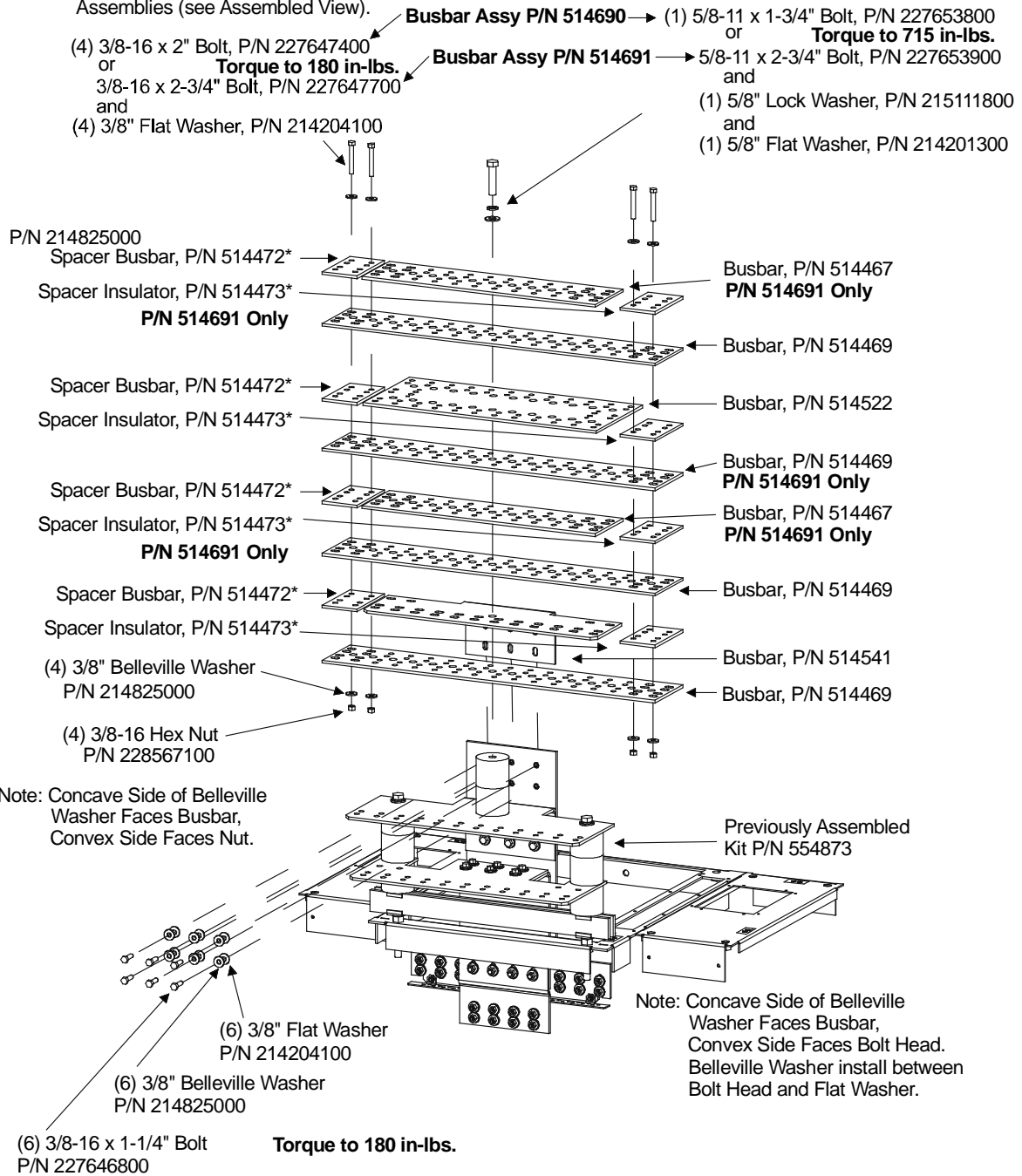


**Figure 4.41 Power/Distribution Bay External Top-Mount Ground (Load Return) Busbar Assembly (P/N 514690 or 514691)
Assembly Procedure Step 2A**

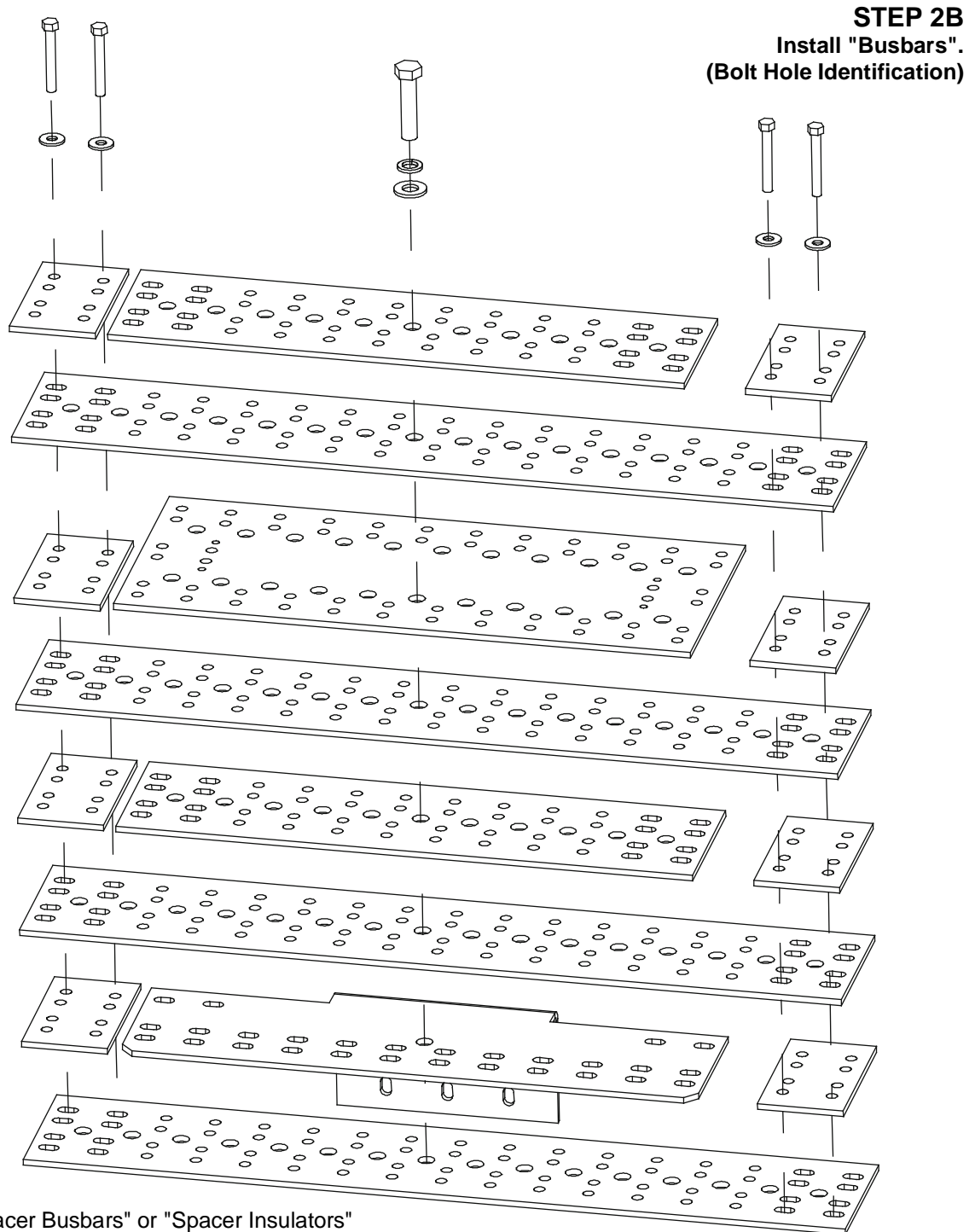
STEP 2A
Install "Busbars".
(see Step 2B for Bolt Hole Identification)
(see Step 2C for Assembled View)

* Use "Spacer Busbars" or "Spacer Insulators" on end bays or stand-alone bays. For multiple bays, use "Spacer Busbars" and move out to 'bridge' between busbars of both Assemblies (see Assembled View).

Note: Apply Electrical Anti-Oxidation Compound to all Busbar Mating Surfaces.

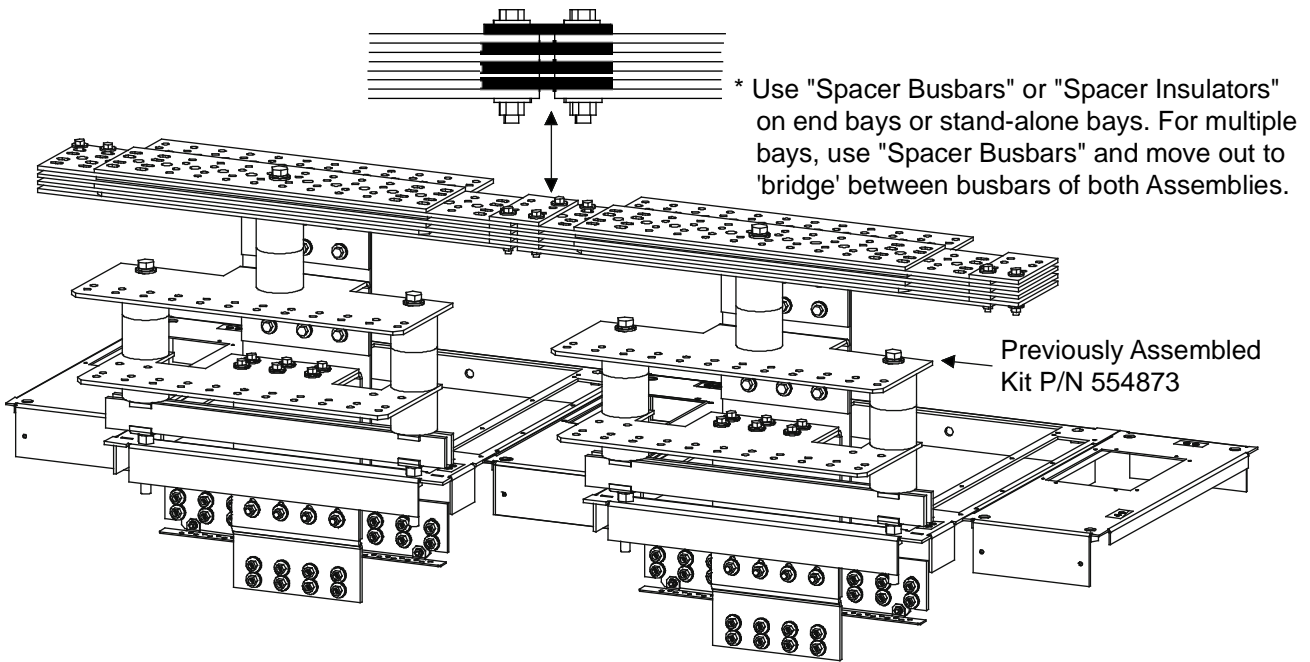
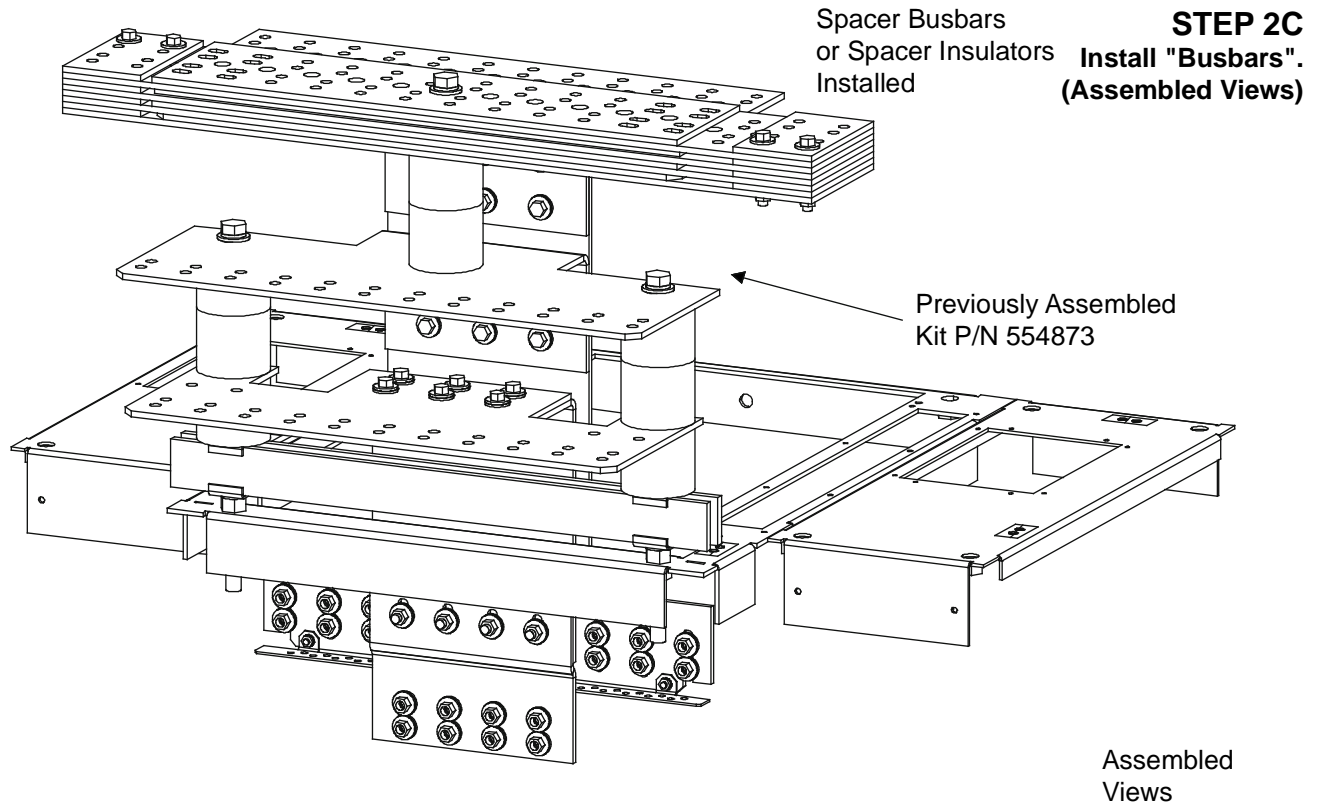


**Figure 4.42 Power/Distribution Bay External Top-Mount Ground (Load Return) Busbar Assembly (P/N 514690 or 514691)
Assembly Procedure Step 2B**



* Use "Spacer Busbars" or "Spacer Insulators" on end bays or stand-alone bays. For multiple bays, use "Spacer Busbars" and move out to 'bridge' between busbars of both Assemblies (see Assembled View).

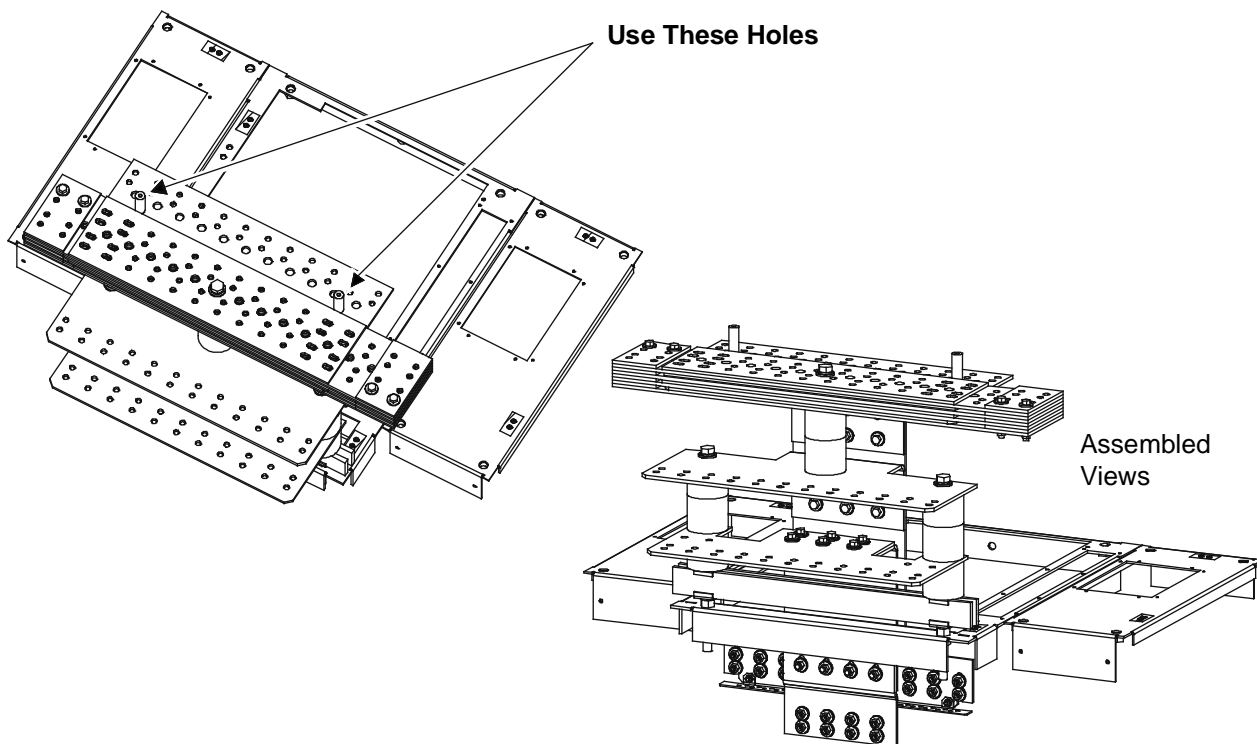
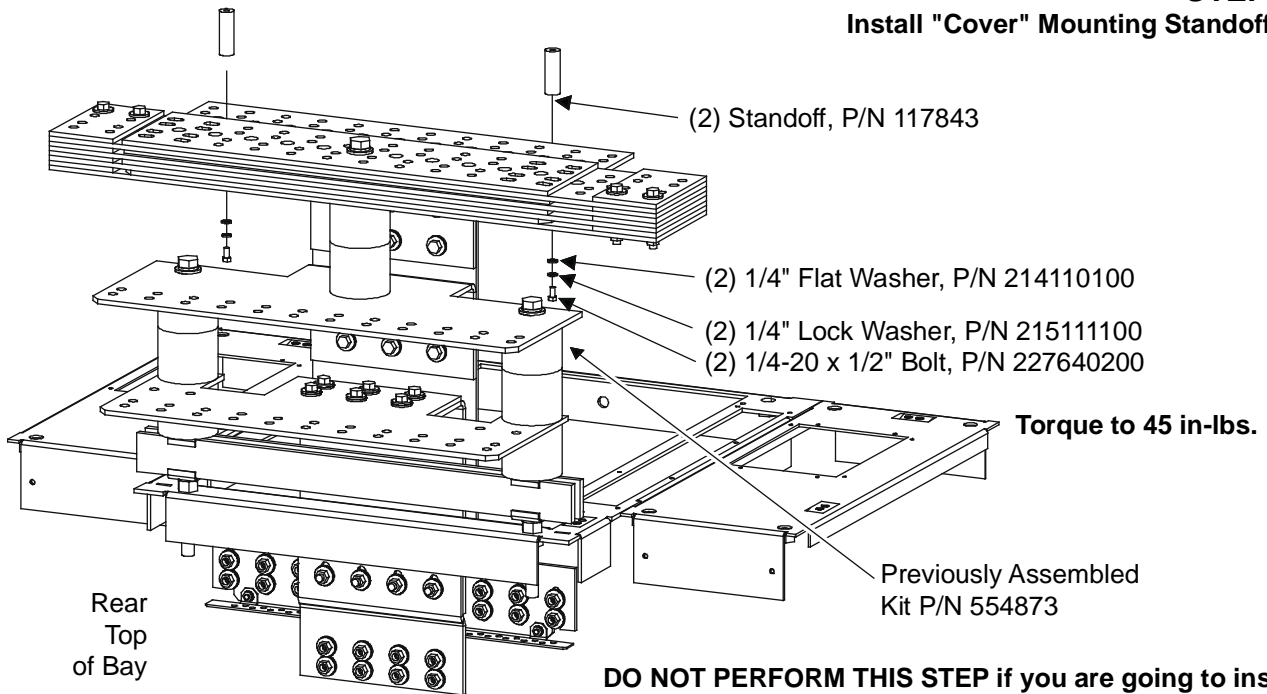
Figure 4.43 Power/Distribution Bay External Top-Mount Ground (Load Return) Busbar Assembly (P/N 514690 or 514691)
Assembly Procedure Step 2C



**Figure 4.44 Power/Distribution Bay External Top-Mount Ground (Load Return) Busbar Assembly (P/N 514690 or 514691)
Assembly Procedure Step 3**

STEP 3

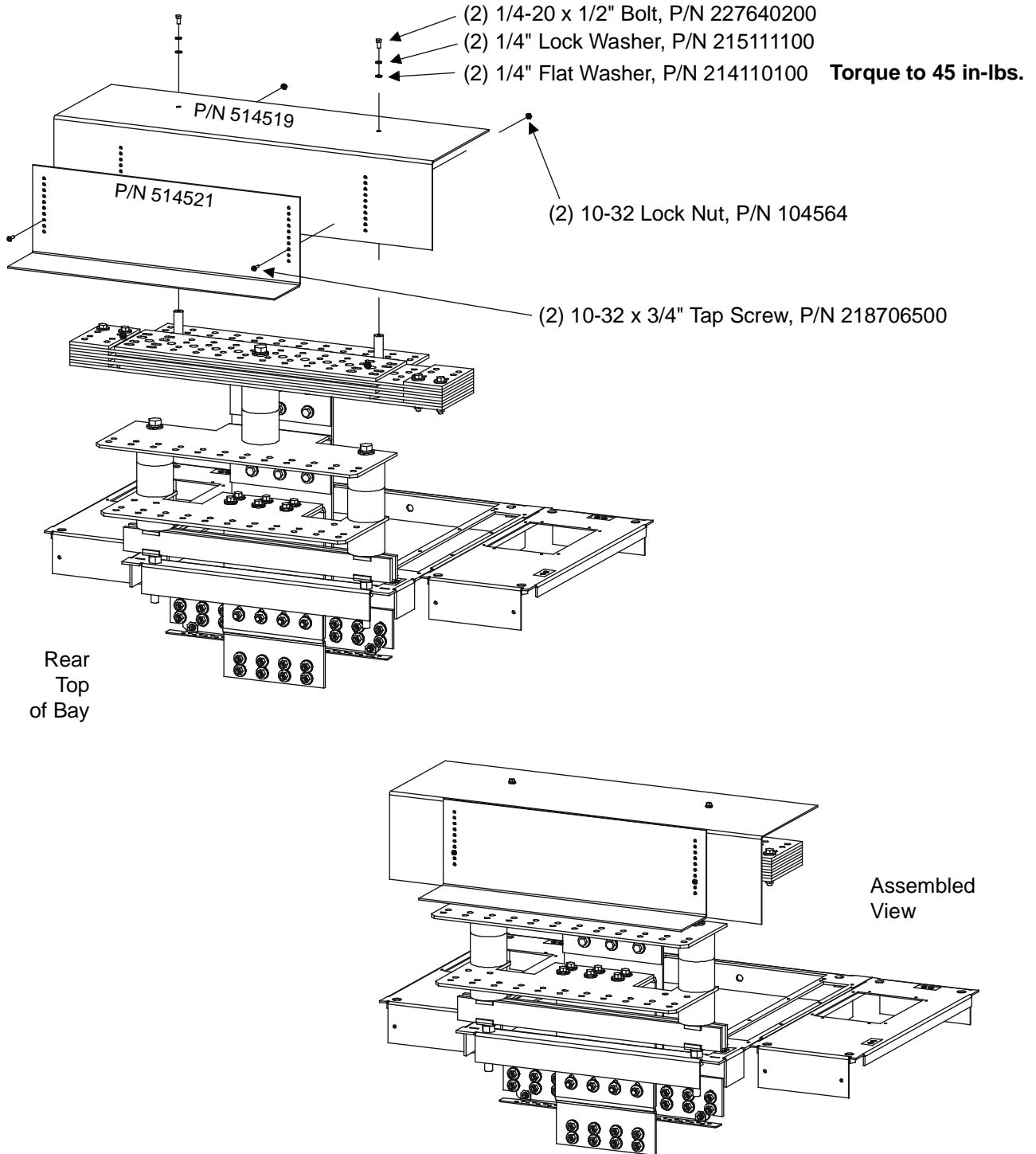
Install "Cover" Mounting Standoffs.



**Figure 4.45 Power/Distribution Bay External Top-Mount Ground (Load Return) Busbar Assembly (P/N 514690 or 514691)
Assembly Procedure Step 4**

**DO NOT PERFORM THIS STEP if you are going to install
"Load Return Lug Extension Busbar Assembly" P/N 514543**

**STEP 4
Install "Covers".**



4.12 Installing Power/Distribution Bay Load Return Lug Extension Busbar Assembly, P/N 514543 (if furnished)

Tools and Material Required to Install the Busbar Assembly

- a) 9/16" Wrench (for 3/8" Hardware)
- b) Cross-Blade Screwdriver
- c) Anti-Oxidation Compound
- d) Torque Wrench

Installation Procedure



DANGER! Before performing this procedure, ensure that the power/distribution bay is COMPLETELY DISCONNECTED from all power sources.



NOTE! Apply electrical anti-oxidation compound to mating surfaces of busbars before connecting together.

1. Assemble the busbar kit to the top of the bays as shown in **Figure 4.46** through **Figure 4.51**. Refer to **Figure 4.52** and **Figure 4.53** for assembled views. Note that this busbar kit requires "External Top-Mount Ground (Load Return) Busbar Assembly" P/N 514688, 514689, 514690, or 514691. This busbar kit attaches to the P/N 514688, 514689, 514690, and 514691 busbar kits.

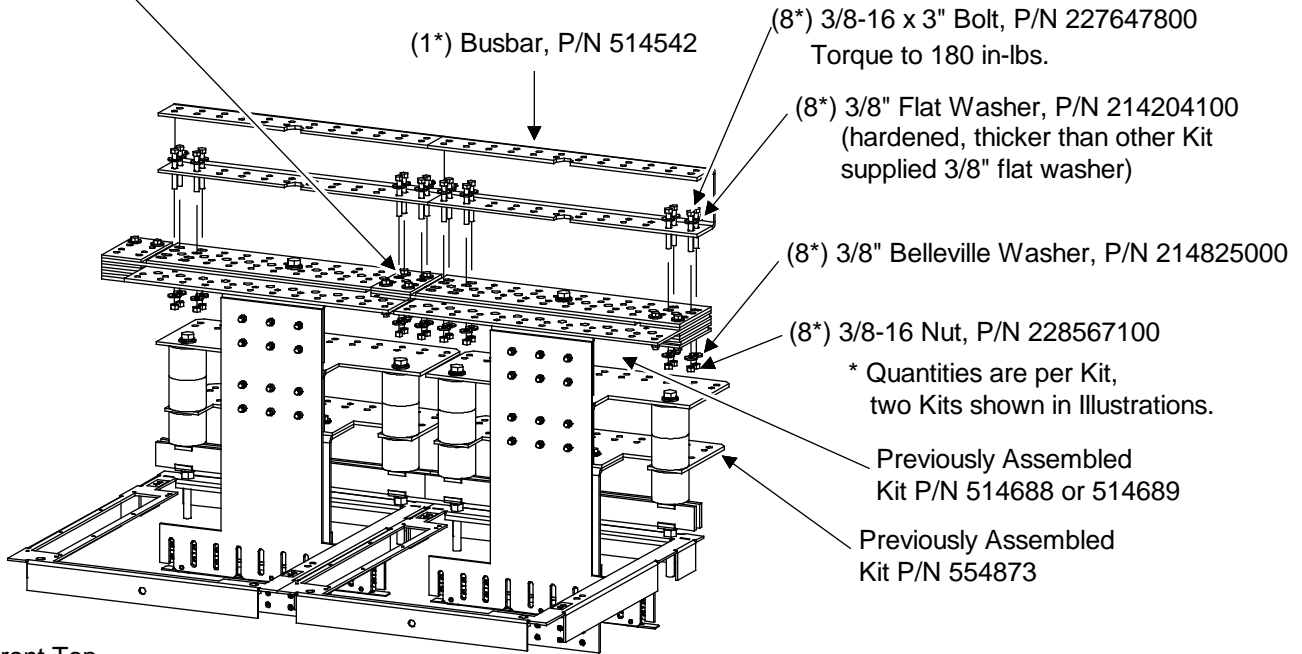
Figure 4.46 Power/Distribution Bay Load Return Lug Extension Busbar Assembly (P/N 514543) Assembly Procedure Step 1A

STEP 1A

**Install "Load Return Lug Extension Busbar"
(List 101 and 111 Bays).**

Remove any
previously installed
bolts from these
four locations

Note: Apply Electrical Anti-Oxidation
Compound to all Busbar
Mating Surfaces.



Front Top
of Bay

Note: Concave Side of Belleville
Washer Faces Busbar,
Convex Side Faces Bolt Head.

Assembled
View

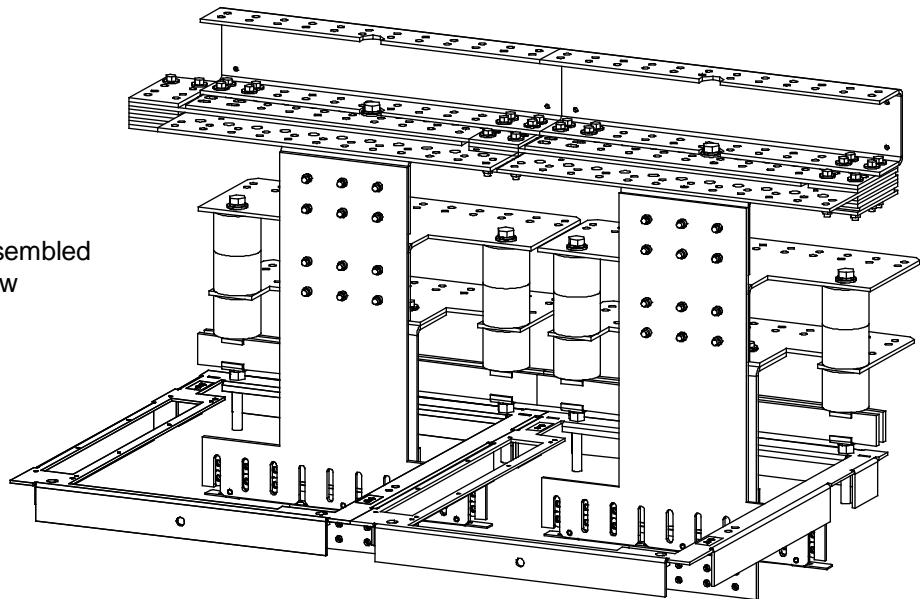


Figure 4.47 Power/Distribution Bay Load Return Lug Extension Busbar Assembly (P/N 514543) Assembly Procedure Step 2A

**PROCEDURE PROVIDED FOR REFERENCE ONLY,
INSTALL BOLTS AS LUGS ARE INSTALLED TO BUSBAR**

STEP 2A
Install "Lug Mounting Bolts"
(List 101 and 111 Bays).

* Quantities are per Kit,
two Kits shown in Illustrations.

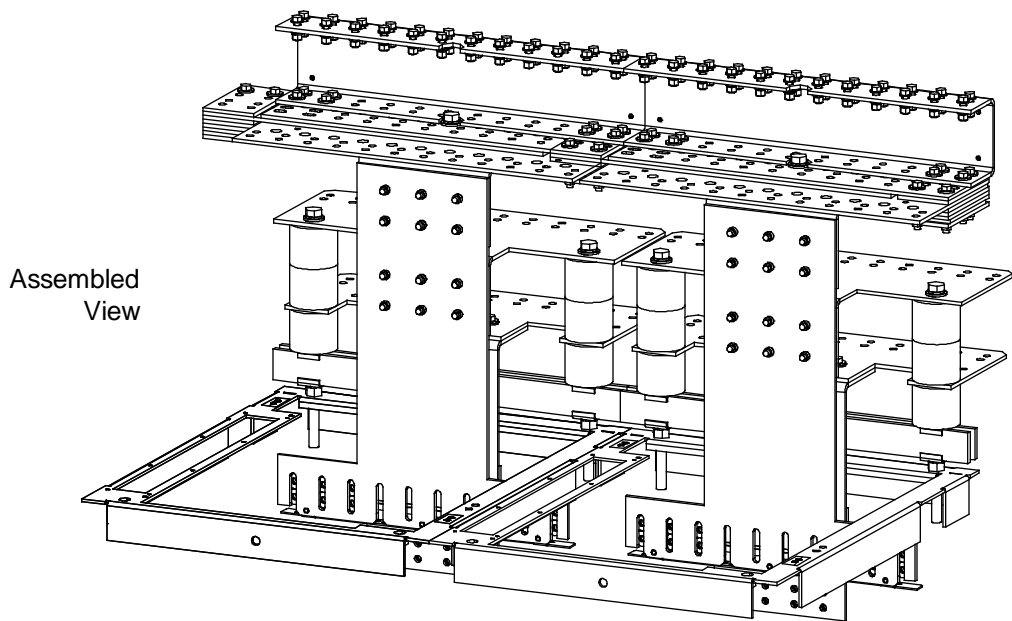
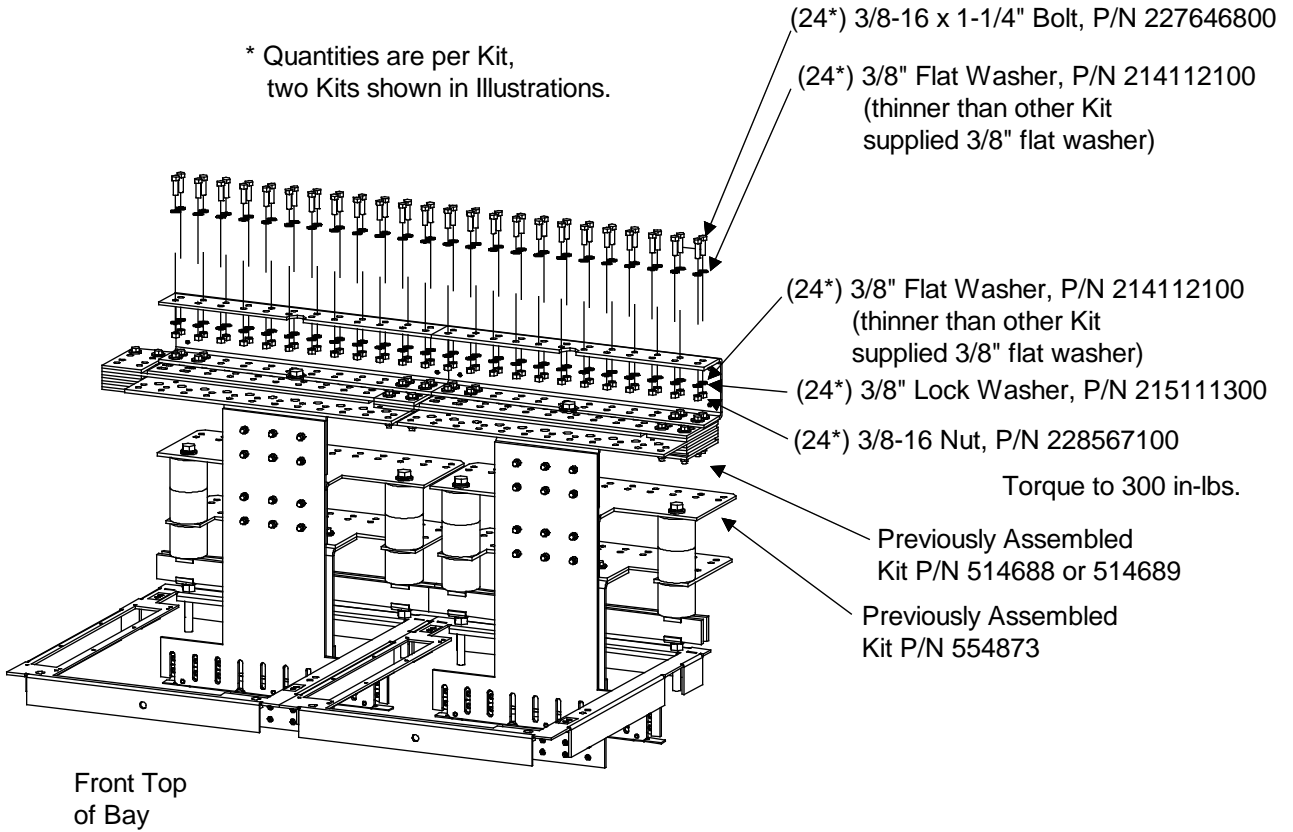
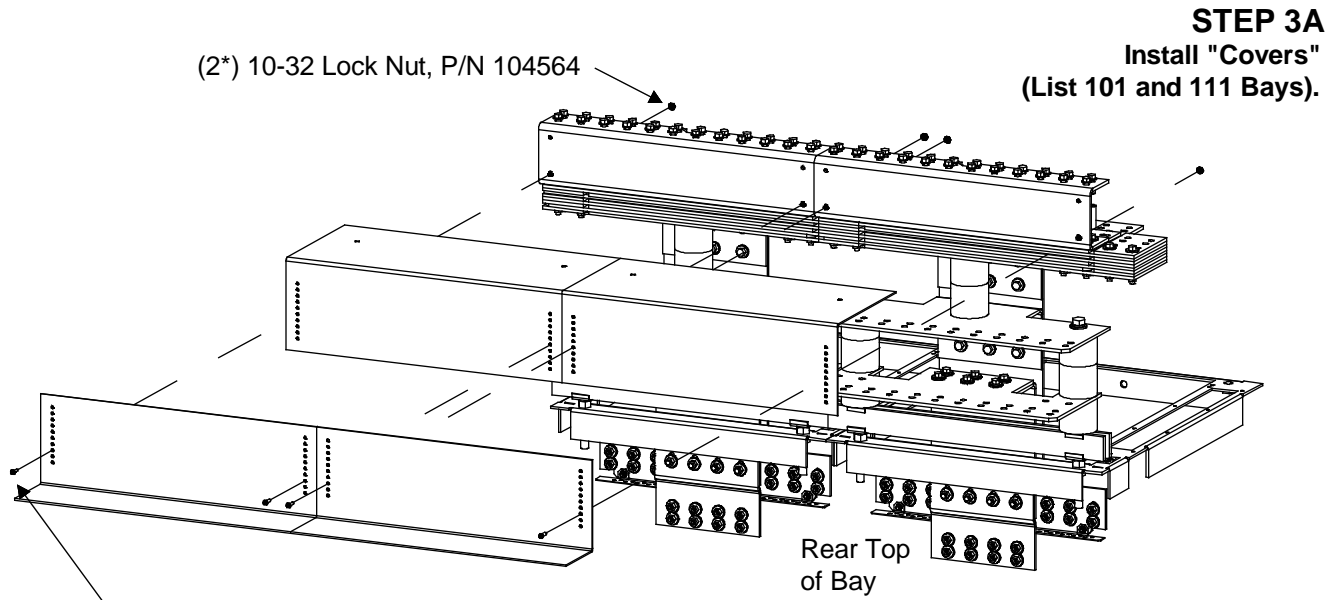


Figure 4.48 Power/Distribution Bay Load Return Lug Extension Busbar Assembly (P/N 514543) Assembly Procedure Step 3A



* Parts are from the P/N 514688 or 514689 Kit.
Quantities are per Kit, two Kits shown in Illustrations.
The following parts are not used: (2) 1/4-20 x 1/2" Bolt (P/N 227640200), (2) 1/4" Lock Washer (P/N 215111100), (2) 1/4" Flat Washer (P/N 214110100)

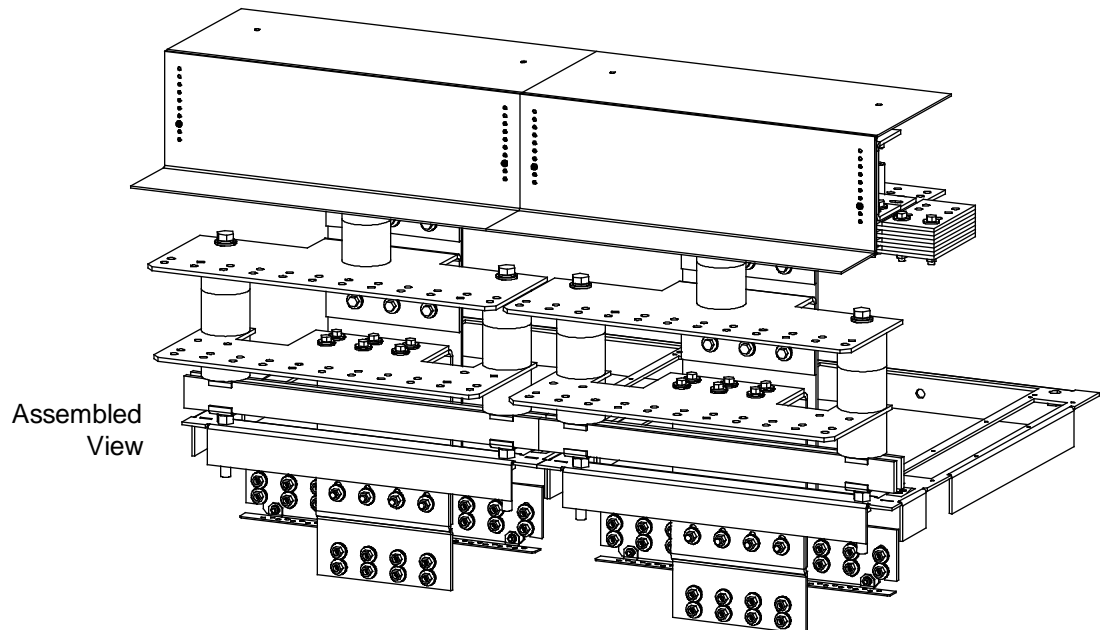
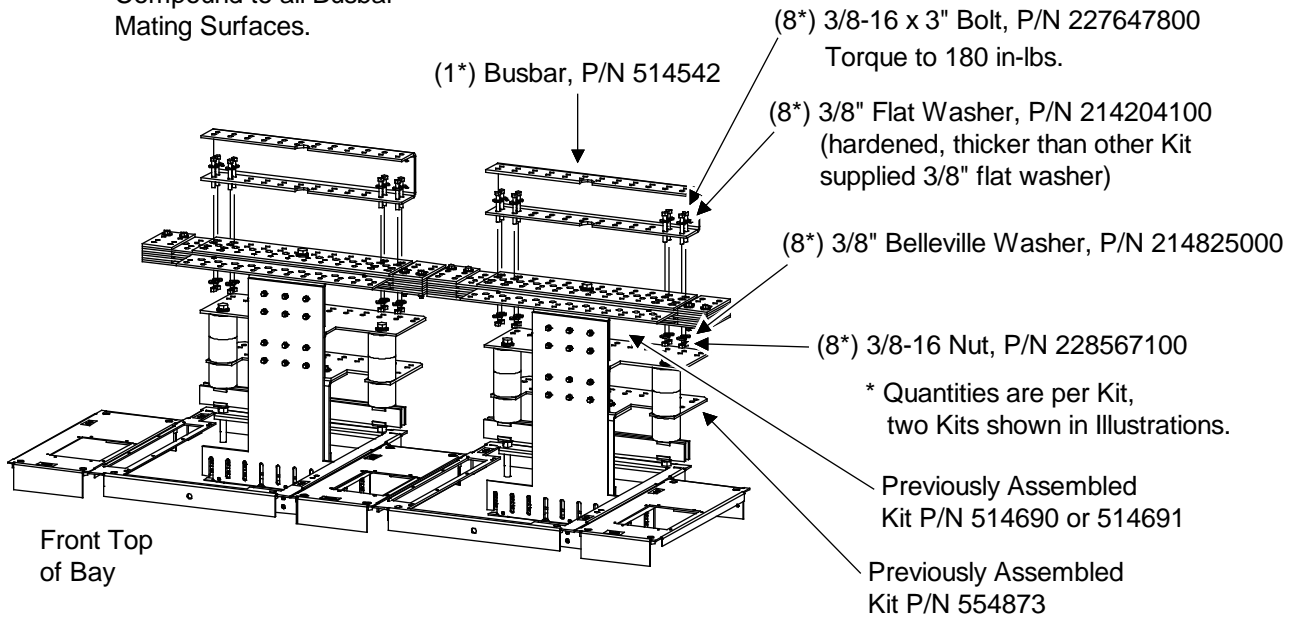


Figure 4.49 Power/Distribution Bay Load Return Lug Extension Busbar Assembly (P/N 514543) Assembly Procedure Step 1B

STEP 1B

**Install "Load Return Lug Extension Busbar"
(List 102 and 112 Bays E/W List 130 or 131 PDSC).**

Note: Apply Electrical Anti-Oxidation Compound to all Busbar Mating Surfaces.



Note: Concave Side of Belleville Washer Faces Busbar, Convex Side Faces Bolt Head.

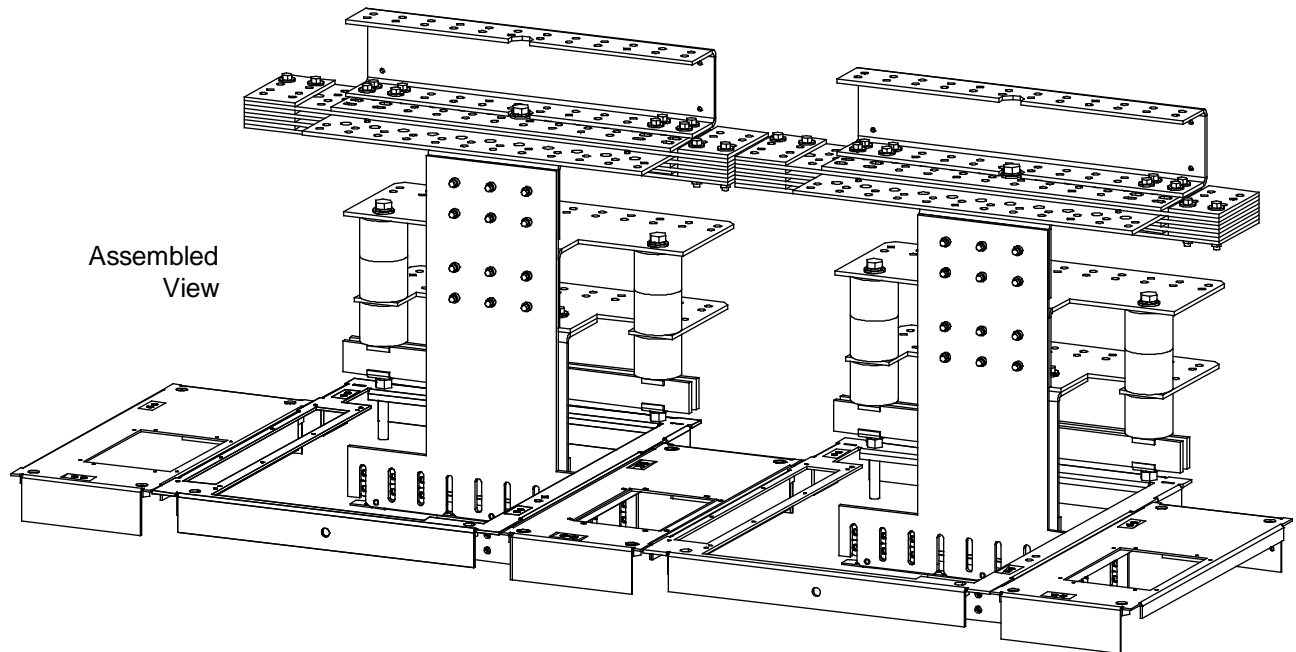


Figure 4.50 Power/Distribution Bay Load Return Lug Extension Busbar Assembly (P/N 514543) Assembly Procedure Step 2B

STEP 2B

Install "Lug Mounting Bolts"

(List 102 and 112 Bays E/W List 130 or 131 PDSC).

PROCEDURE PROVIDED FOR REFERENCE ONLY, INSTALL BOLTS AS LUGS ARE INSTALLED TO BUSBAR

* Quantities are per Kit,
two Kits shown in Illustrations.

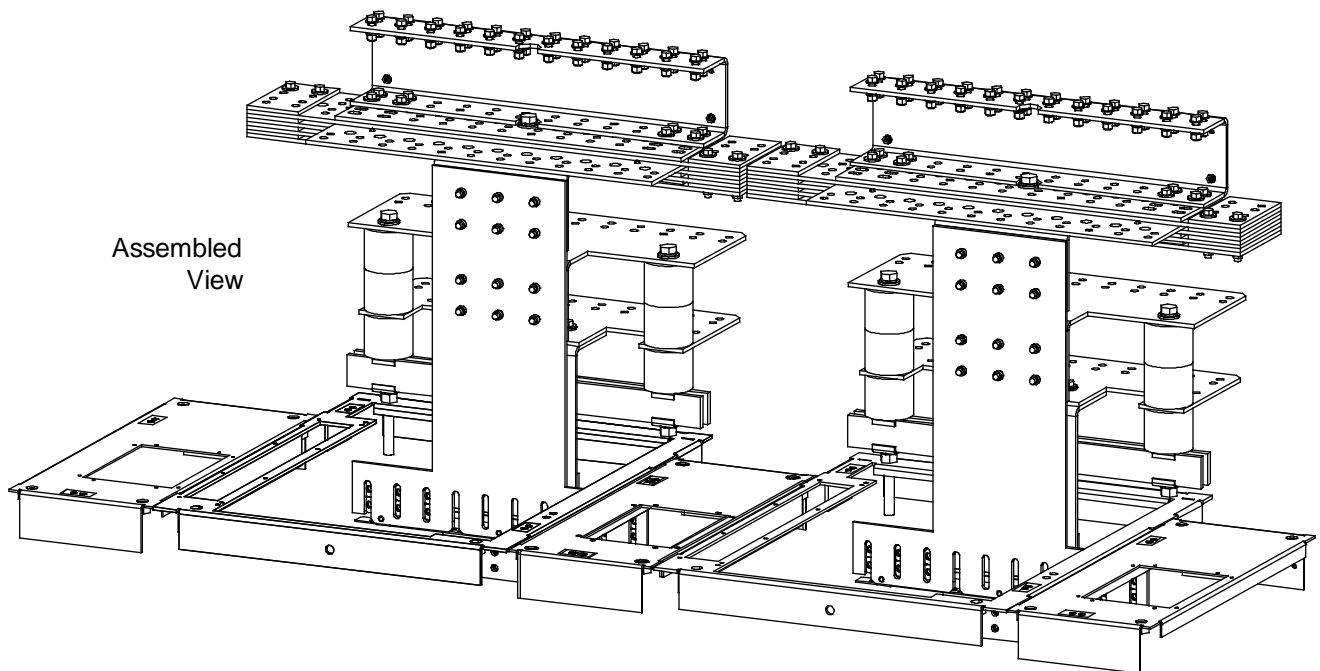
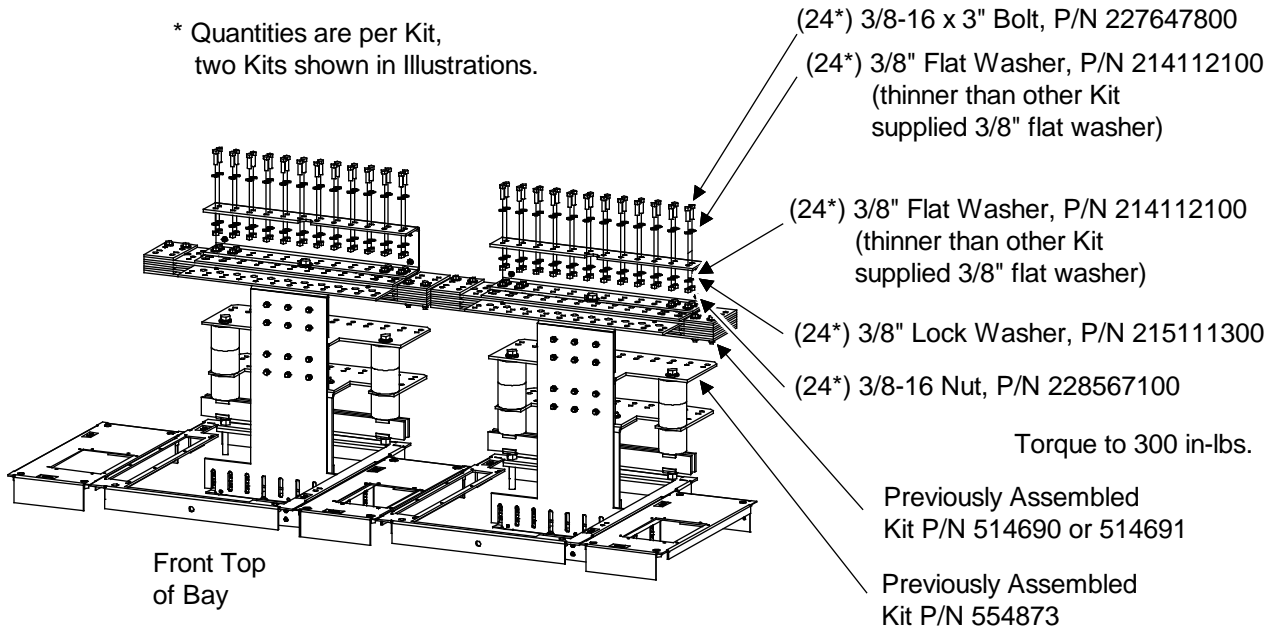


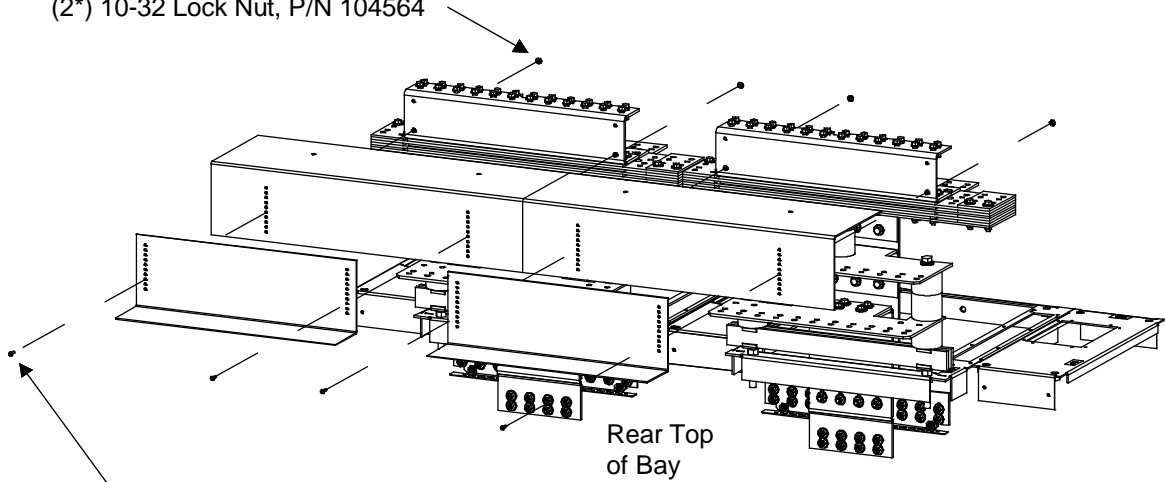
Figure 4.51 Power/Distribution Bay Load Return Lug Extension Busbar Assembly (P/N 514543) Assembly Procedure Step 3B

STEP 3B

Install "Covers"

(List 102 and 112 Bays E/W List 130 or 131 PDSC).

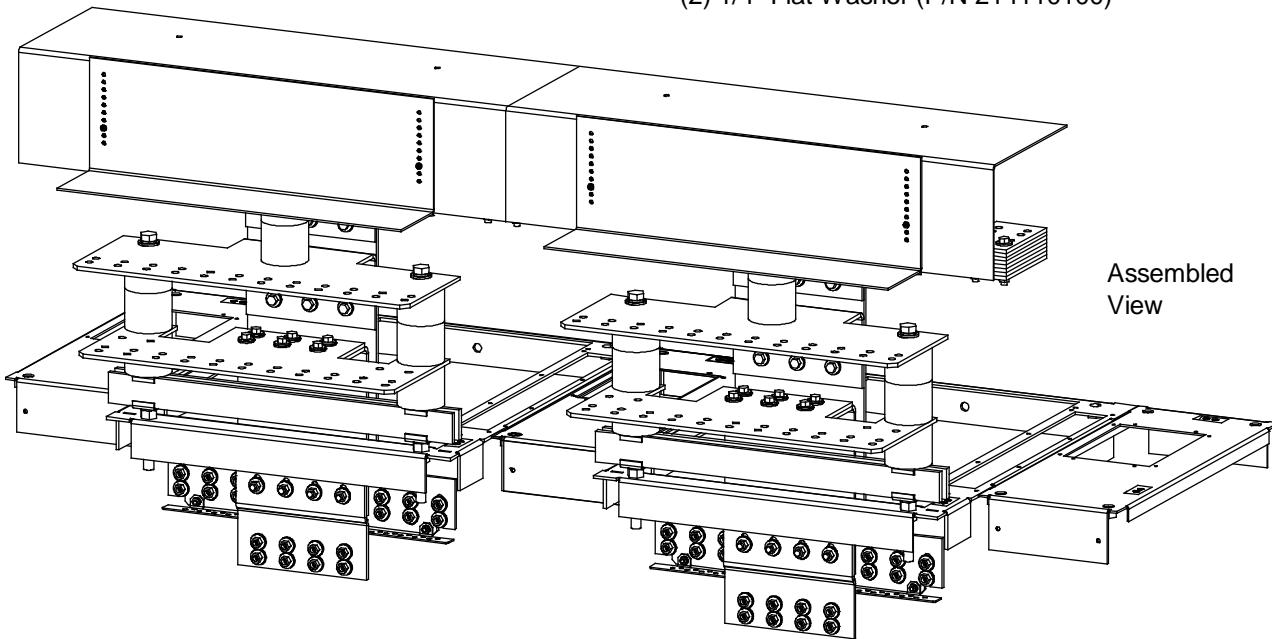
(2*) 10-32 Lock Nut, P/N 104564



Rear Top
of Bay

(2*) 10-32 x 3/4" Tap Screw, P/N 218706500

* Parts are from the P/N 514690 or 514691 Kit.
Quantities are per Kit, two Kits shown in Illustrations.
The following parts are not used: (2) 1/4-20 x 1/2" Bolt
(P/N 227640200), (2) 1/4" Lock Washer (P/N 215111100),
(2) 1/4" Flat Washer (P/N 214110100)



Assembled
View

Figure 4.52 Power/Distribution Bay Load Return Lug Extension Busbar Assembly (P/N 514543) Assembled Views

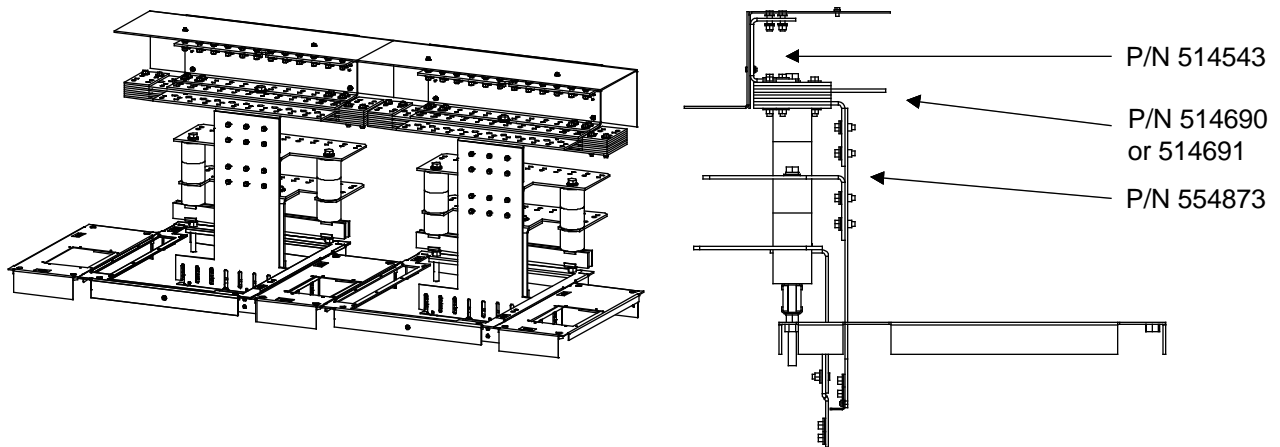
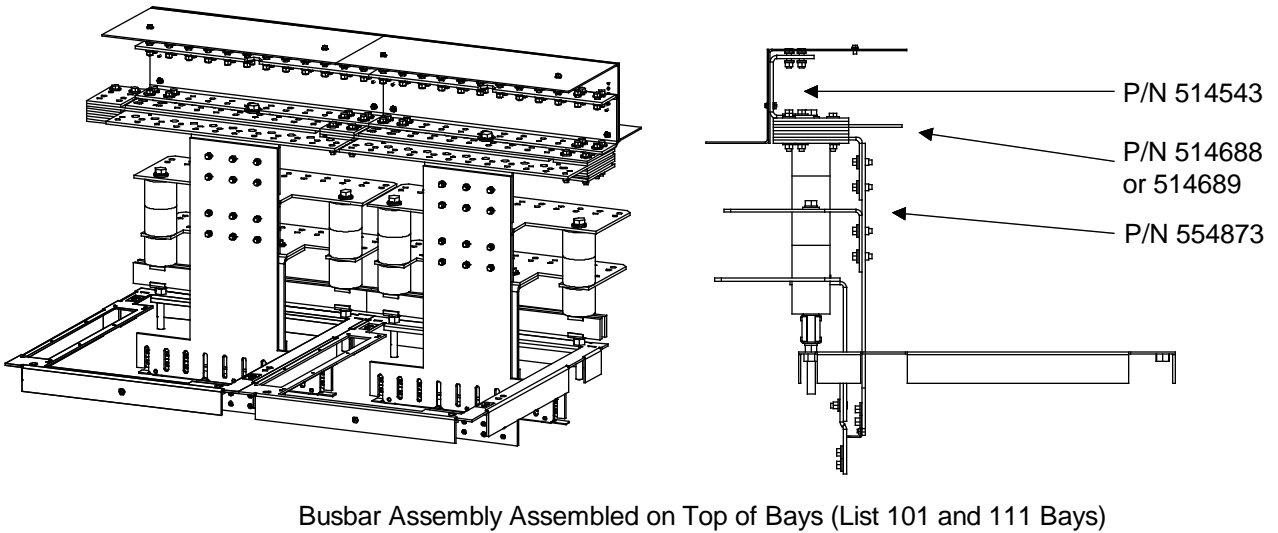
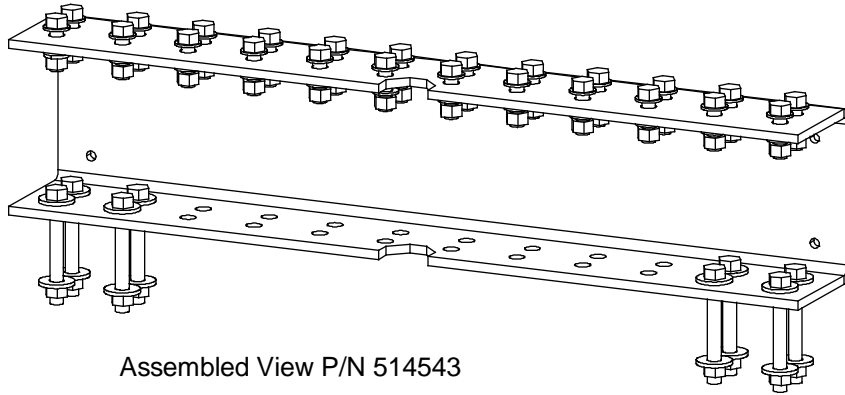
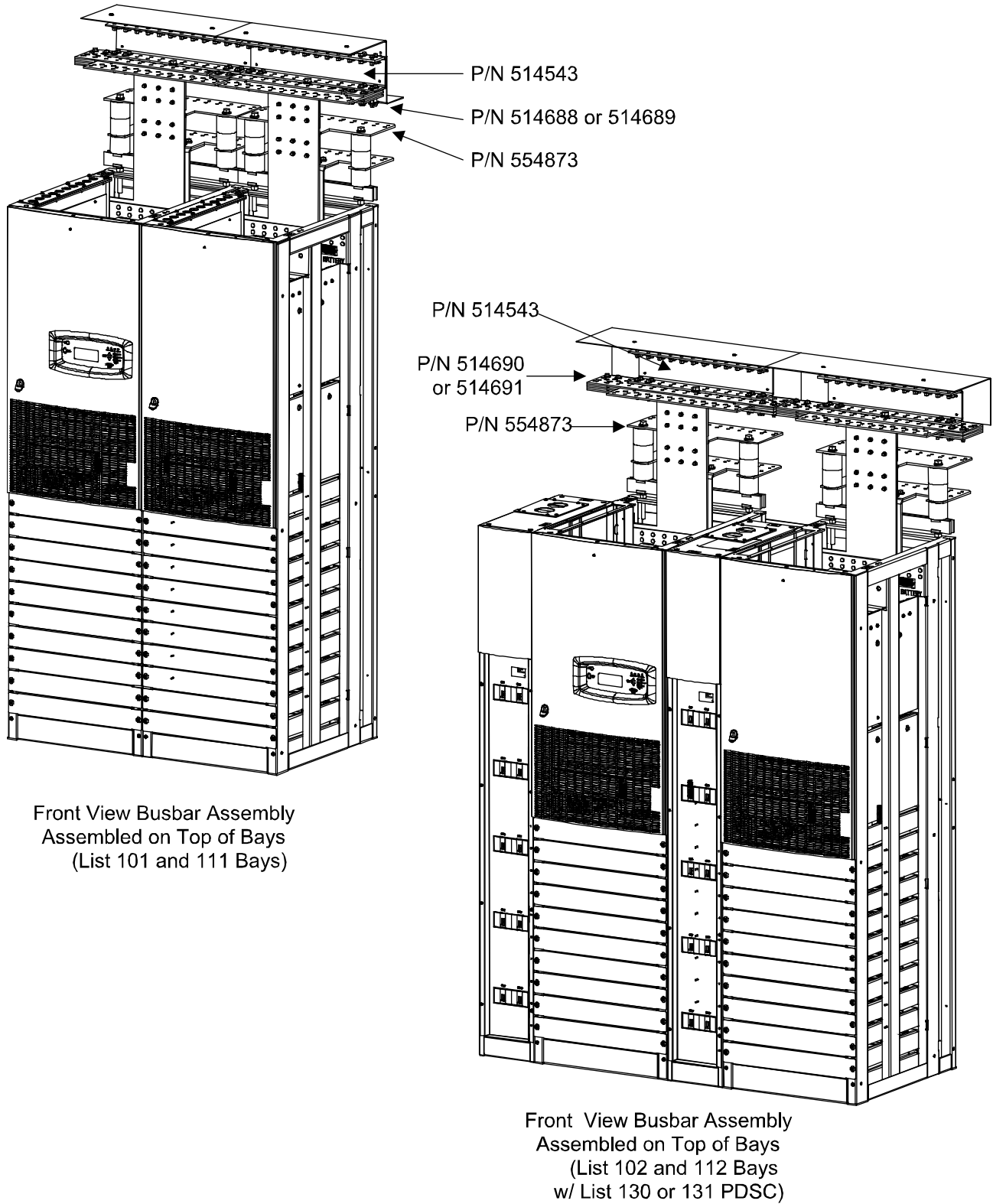


Figure 4.53 Power/Distribution Bay Load Return Lug Extension Busbar Assembly (P/N 514543) Assembled on Top of Bays



4.13 Installing Power/Distribution Bay External Top-Mount Vertical Battery Input Busbar Assembly, P/N 554874 (if furnished)

Tools and Material Required to Install the Busbar Assembly

- a) 9/16" Wrench (for 3/8" Hardware)
- b) 15/16" Wrench (for 5/8" Hardware)
- c) Channel Locks
- d) Anti-Oxidation Compound
- e) Torque Wrench

Installation Procedure



DANGER! Before performing this procedure, ensure that the power/distribution bay is COMPLETELY DISCONNECTED from all power sources.



NOTE! Apply electrical anti-oxidation compound to mating surfaces of busbars before connecting together.

1. Assemble the busbar kit to the top of the bays as shown in **Figure 4.54** through **Figure 4.61**.

Figure 4.54 Power/Distribution Bay External Top-Mount Vertical Busbar Assembly (P/N 554874) Assembly Procedure Step 1

STEP 1
Install “Main Positive Busbar” onto
Bay Positive Busbar.

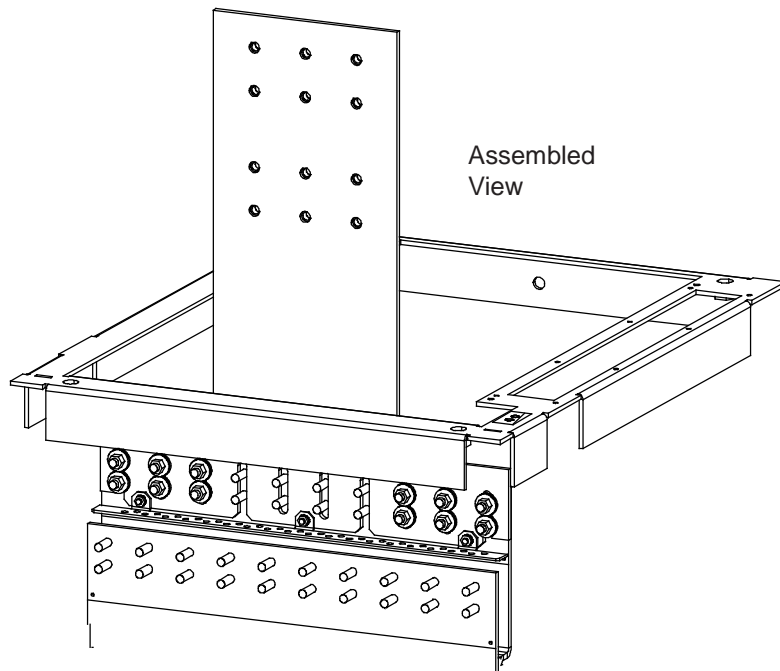
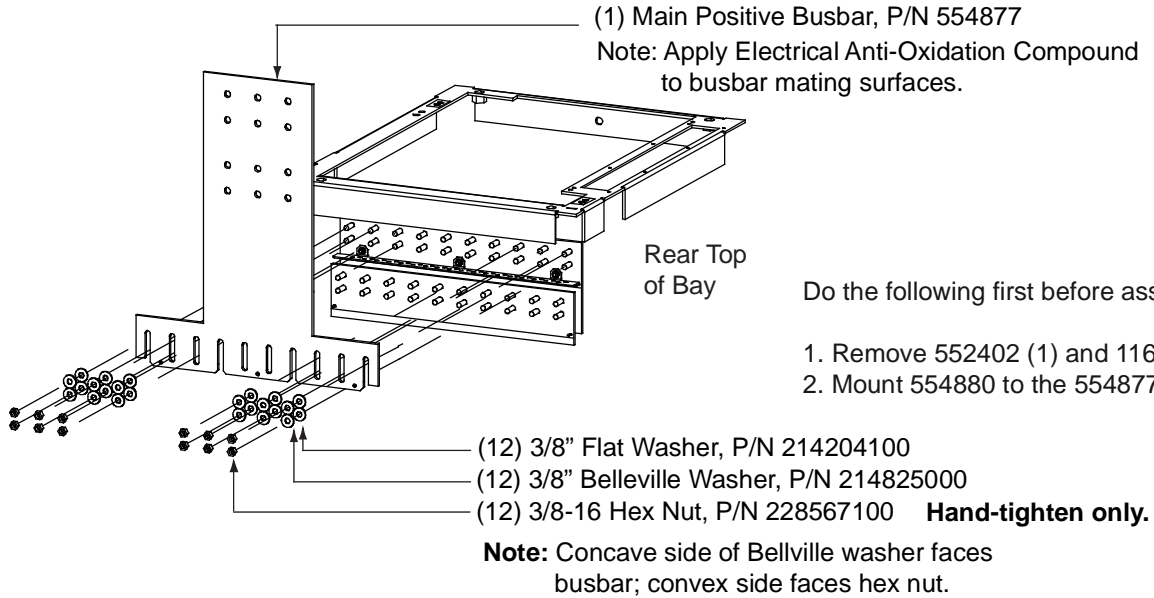


Figure 4.55 Power/Distribution Bay External Top-Mount Vertical Busbar Assembly (P/N 554874) Assembly Procedure Step 2

STEP 2
Install “Support Bar” and “Related Hardware” onto Top of Bay.

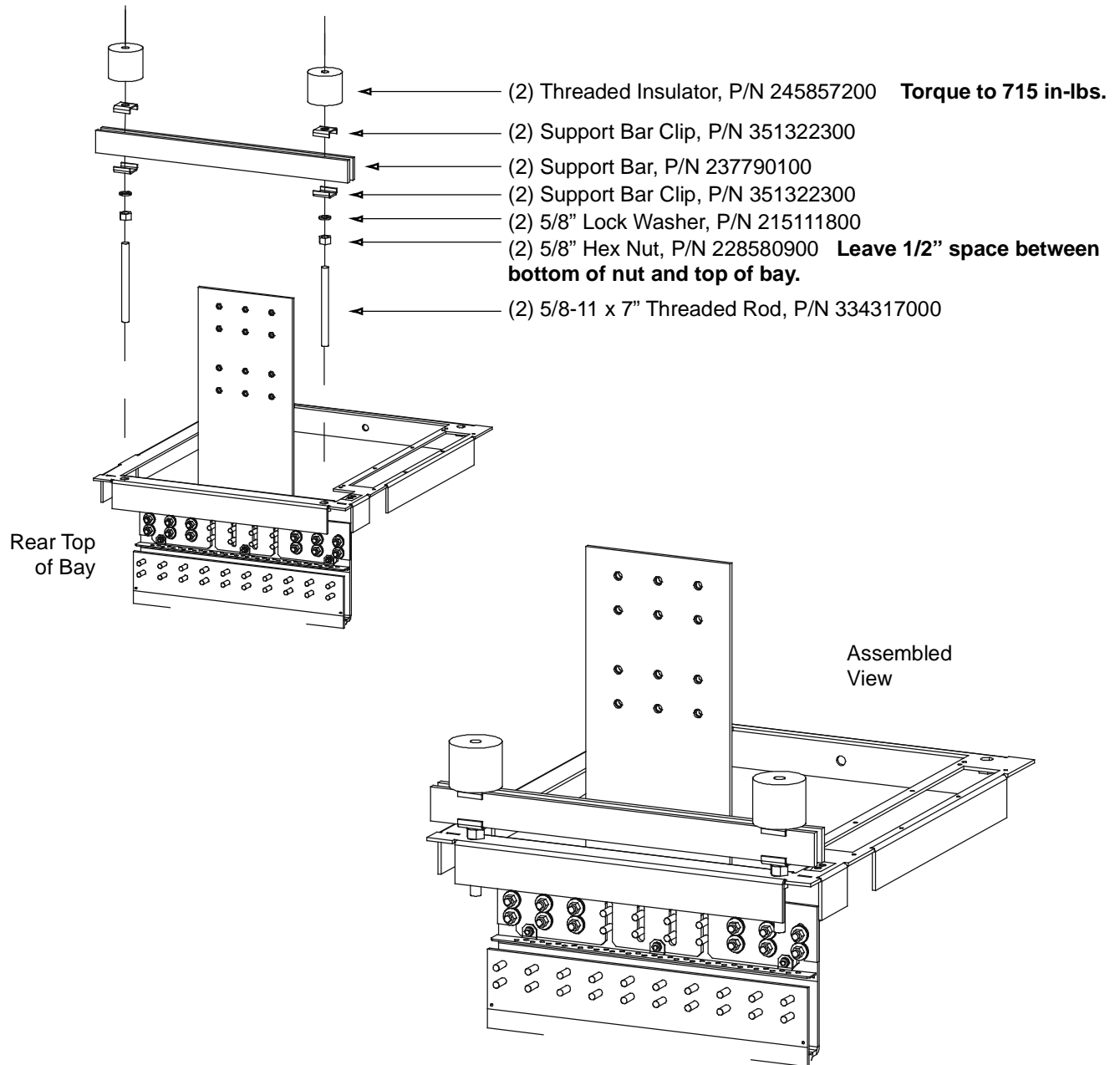
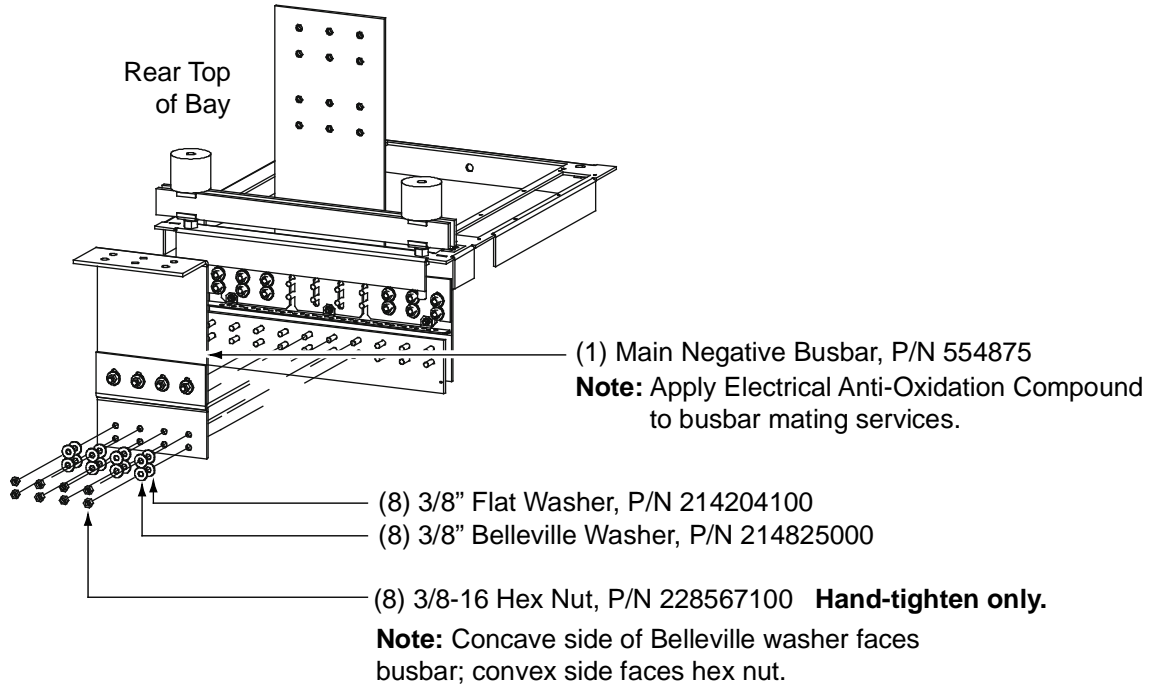


Figure 4.56 Power/Distribution Bay External Top-Mount Vertical Busbar Assembly (P/N 554874) Assembly Procedure Step 3

STEP 3
Install “Main Negative Busbar” onto Bay
Negative Busbar.



Mount 554876 to the 554875.

Hardware:

214204100 (4)

214825000 (4)

228567100 (4)

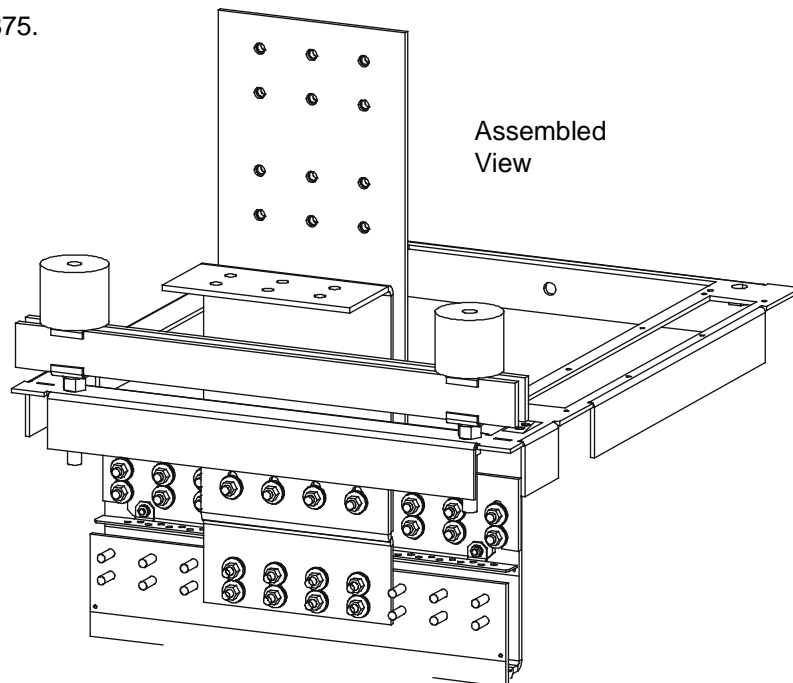


Figure 4.57 Power/Distribution Bay External Top-Mount Vertical Busbar Assembly (P/N 554874) Assembly Procedure Step 4

STEP 4
Install “Vertical Landing Negative Busbar”
onto “Main Negative Busbar”.

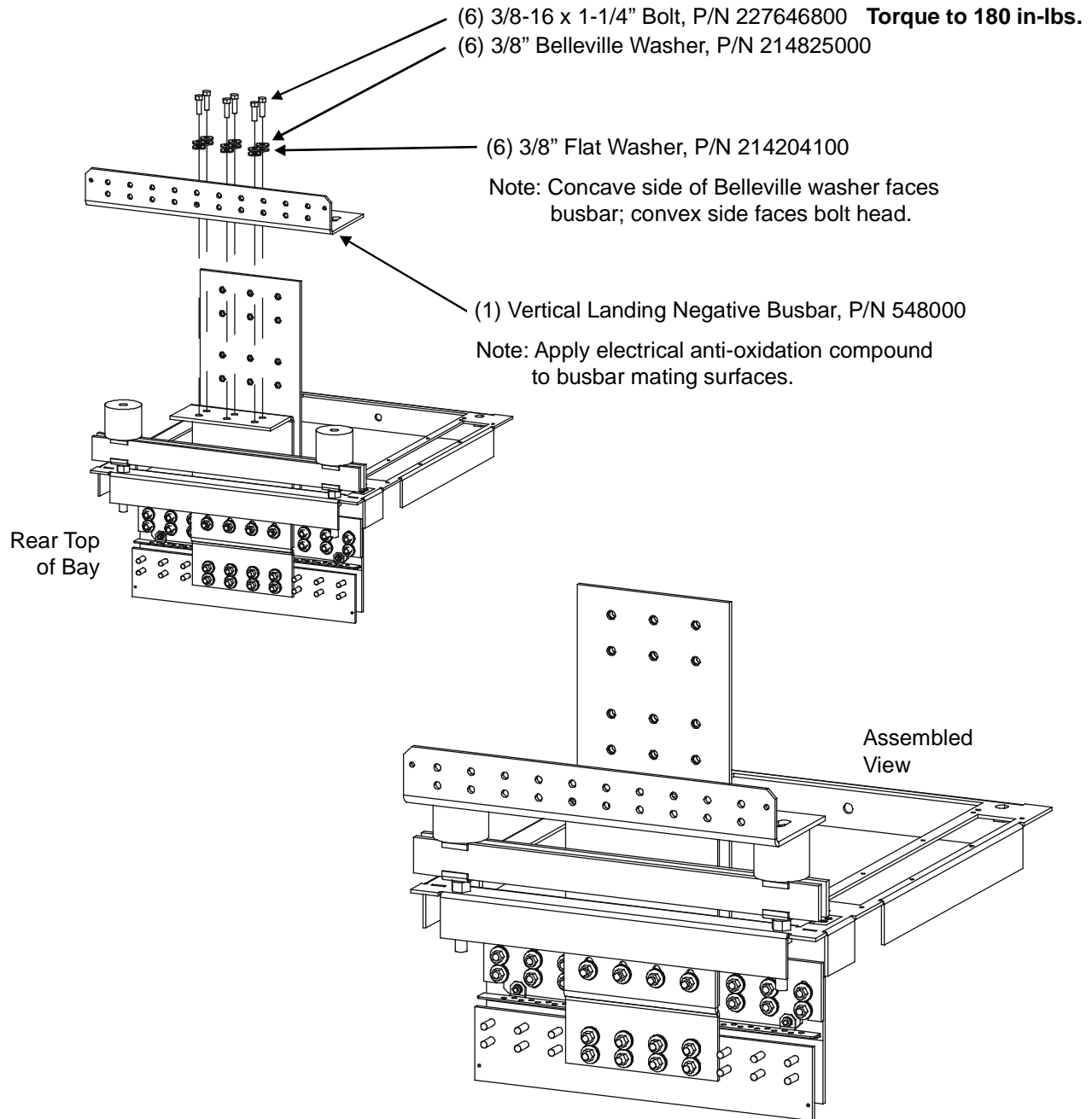


Figure 4.58 Power/Distribution Bay External Top-Mount Vertical Busbar Assembly (P/N 554874) Assembly Procedure Step 5

STEP 5
Install “Threaded Insulators” onto
“Vertical Landing Negative Busbar”.

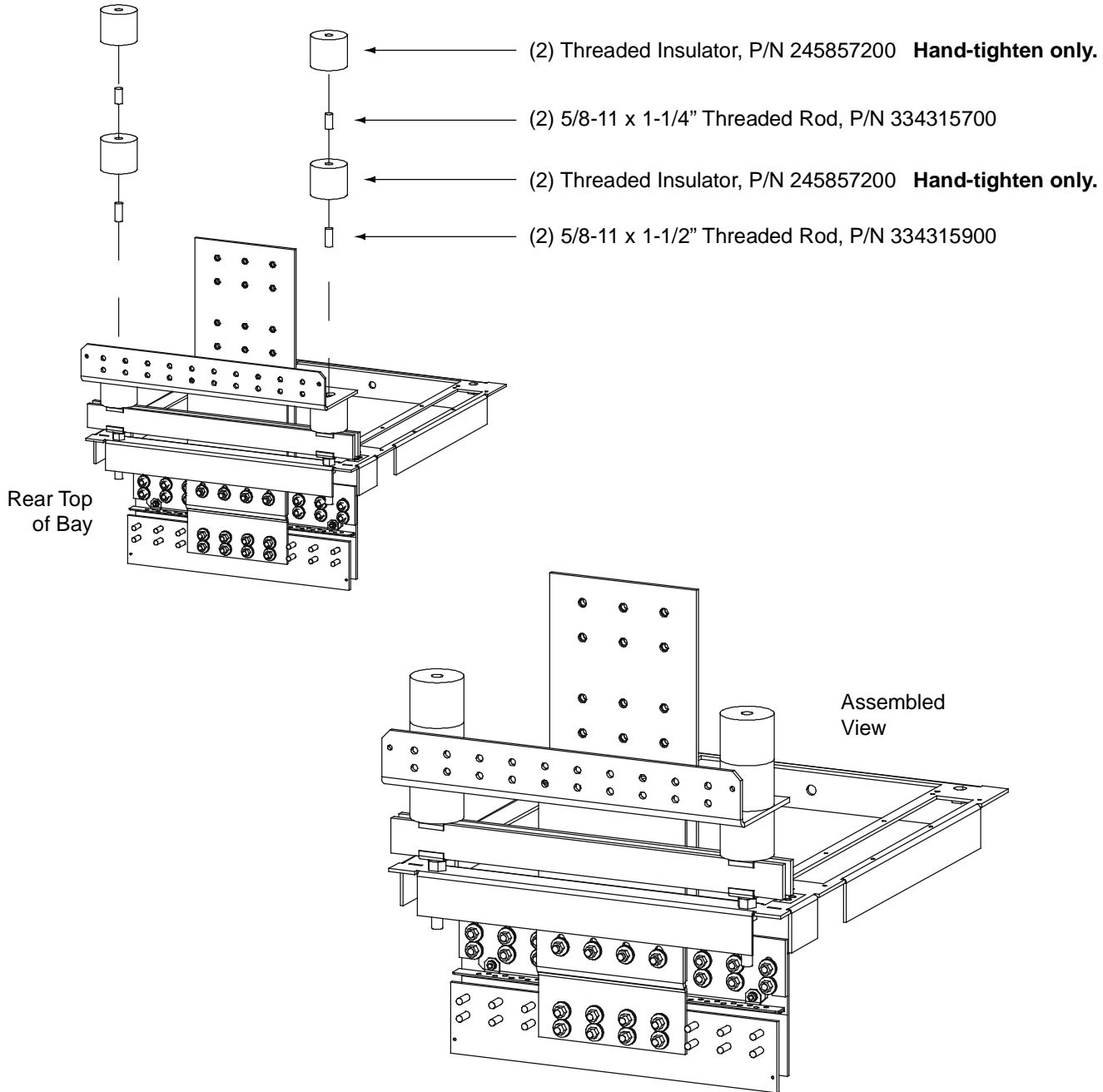


Figure 4.59 Power/Distribution Bay External Top-Mount Vertical Busbar Assembly (P/N 554874) Assembly Procedure Step 6

STEP 6
Install “Vertical Landing Positive Busbar”
onto “Main Positive Busbar”.

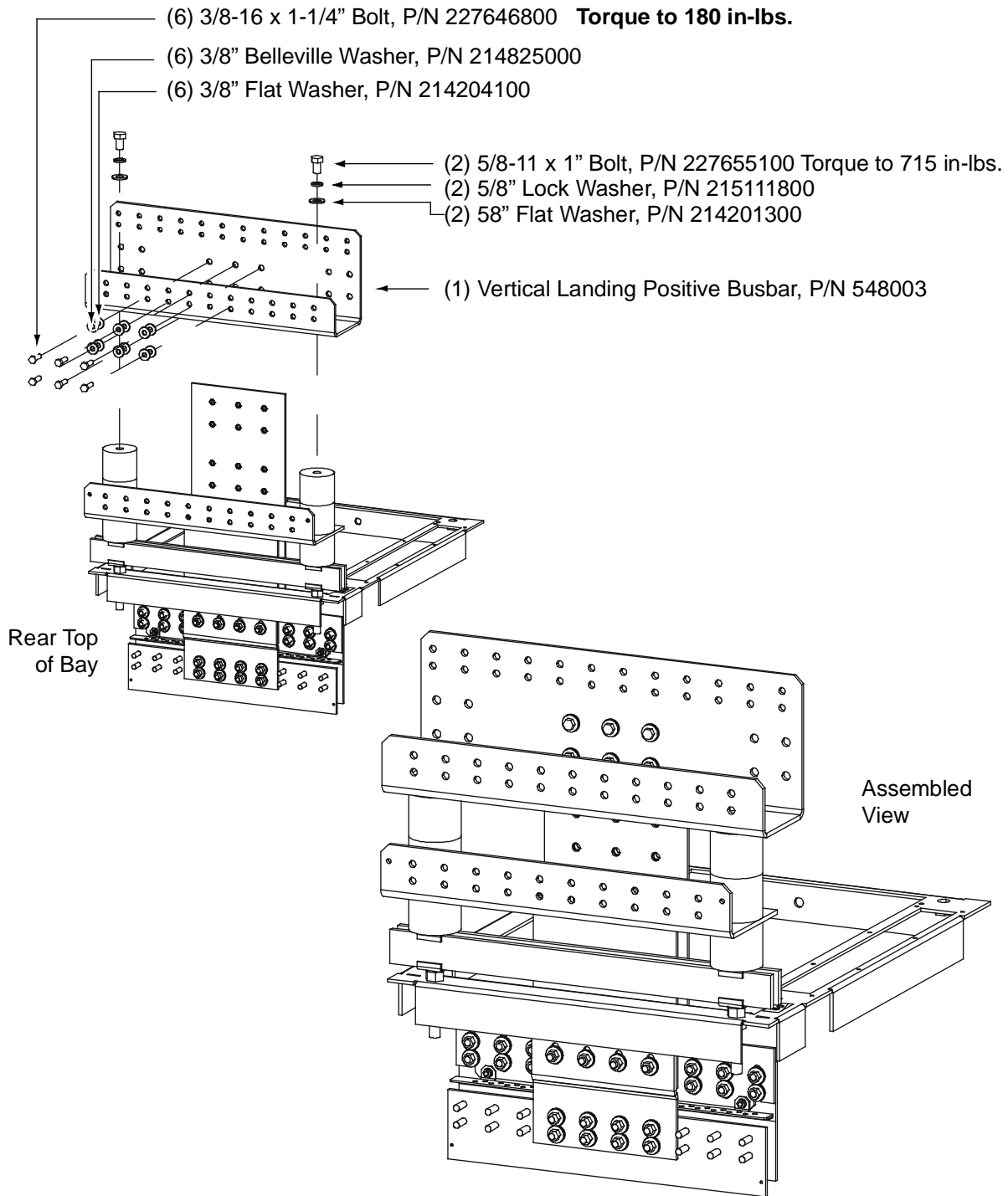


Figure 4.60 Power/Distribution Bay External Top-Mount Vertical Busbar Assembly (P/N 554874) Assembly Procedure Step 7

STEP 7
Final Torque

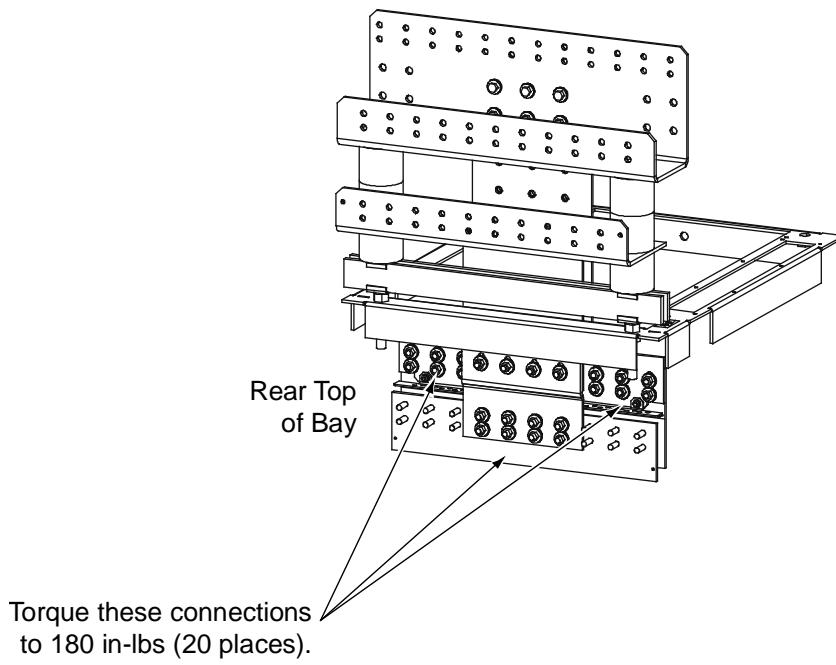
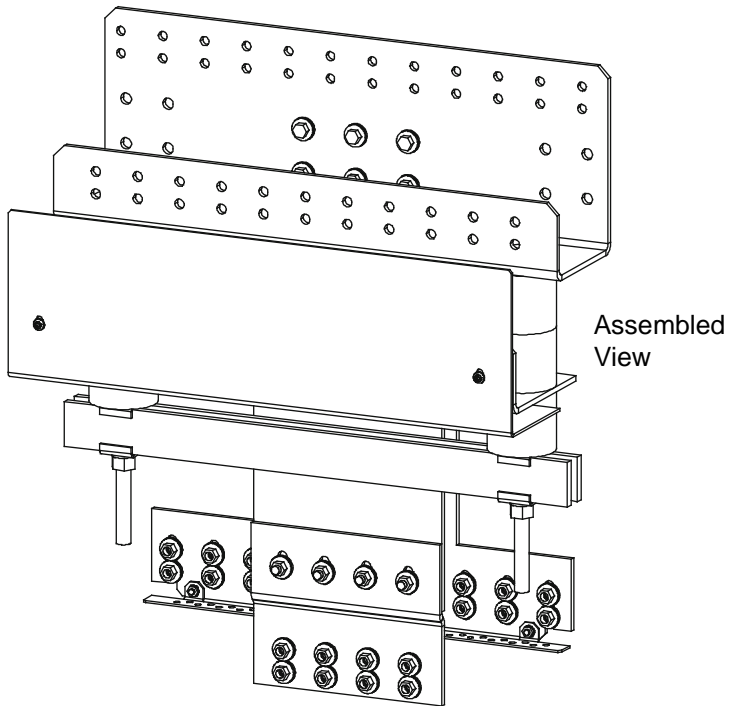
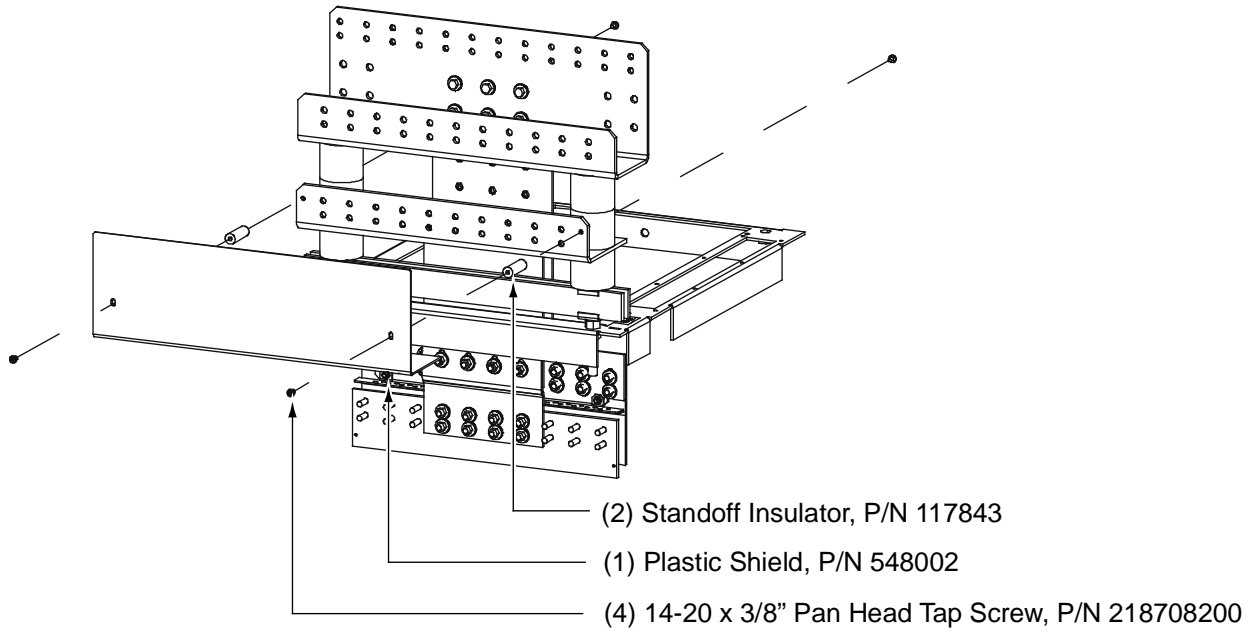


Figure 4.61 Power/Distribution Bay External Top-Mount Vertical Busbar Assembly (P/N 554874) Assembly Procedure Step 8

STEP 8
Install Shield



4.14 Installing Distribution Only Bay External Top-Mount Ground (Load Return) Busbar Assembly; P/N 528775 (if furnished)

Tools and Material Required to Install the Busbar Assembly

- a) 15/16" Wrench (for 5/8" Hardware)
- b) Anti-Oxidation Compound
- c) Torque Wrench

Installation Procedure



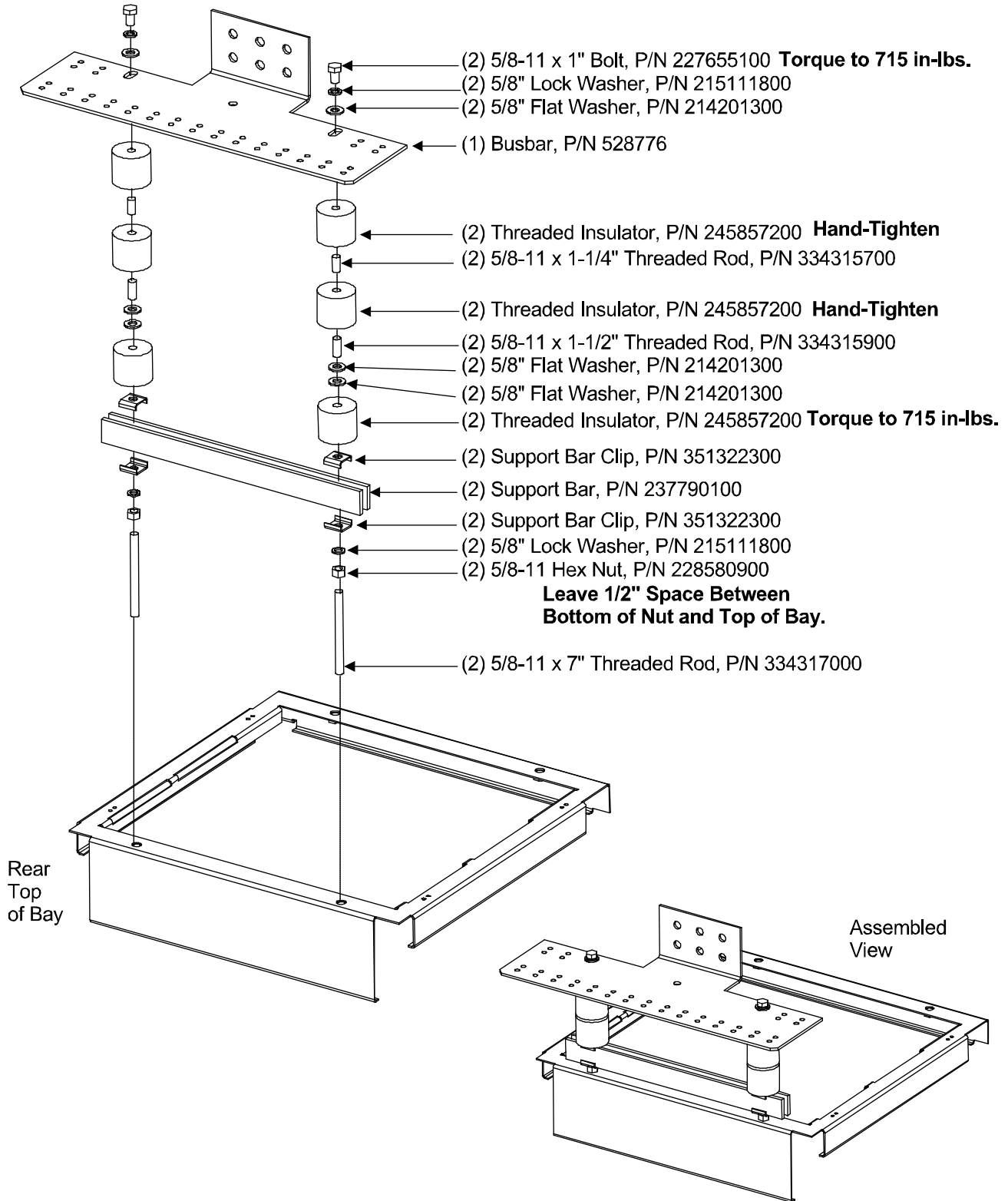
DANGER! Before performing this procedure, ensure that the power/distribution bay is COMPLETELY DISCONNECTED from all power sources.



NOTE! Apply electrical anti-oxidation compound to mating surfaces of busbars before connecting together.

1. Assemble the busbar kit to the top of the bays as shown in **Figure 4.62**.

Figure 4.62 Distribution Only Bay External Top-Mount Ground (Load Return) Busbar Assembly (P/N 528775) Assembly Procedure



4.15 Installing Distribution Only Bay External Top-Mount Ground (Load Return) Extension Busbar Assembly; P/N 528780 (if furnished)

Tools and Material Required to Install the Busbar Assembly

- a) 9/16" Wrench (for 3/8" Hardware)
- b) 15/16" Wrench (for 5/8" Hardware)
- c) Cross-Blade Screwdriver
- d) Anti-Oxidation Compound
- e) Torque Wrench

Installation Procedure



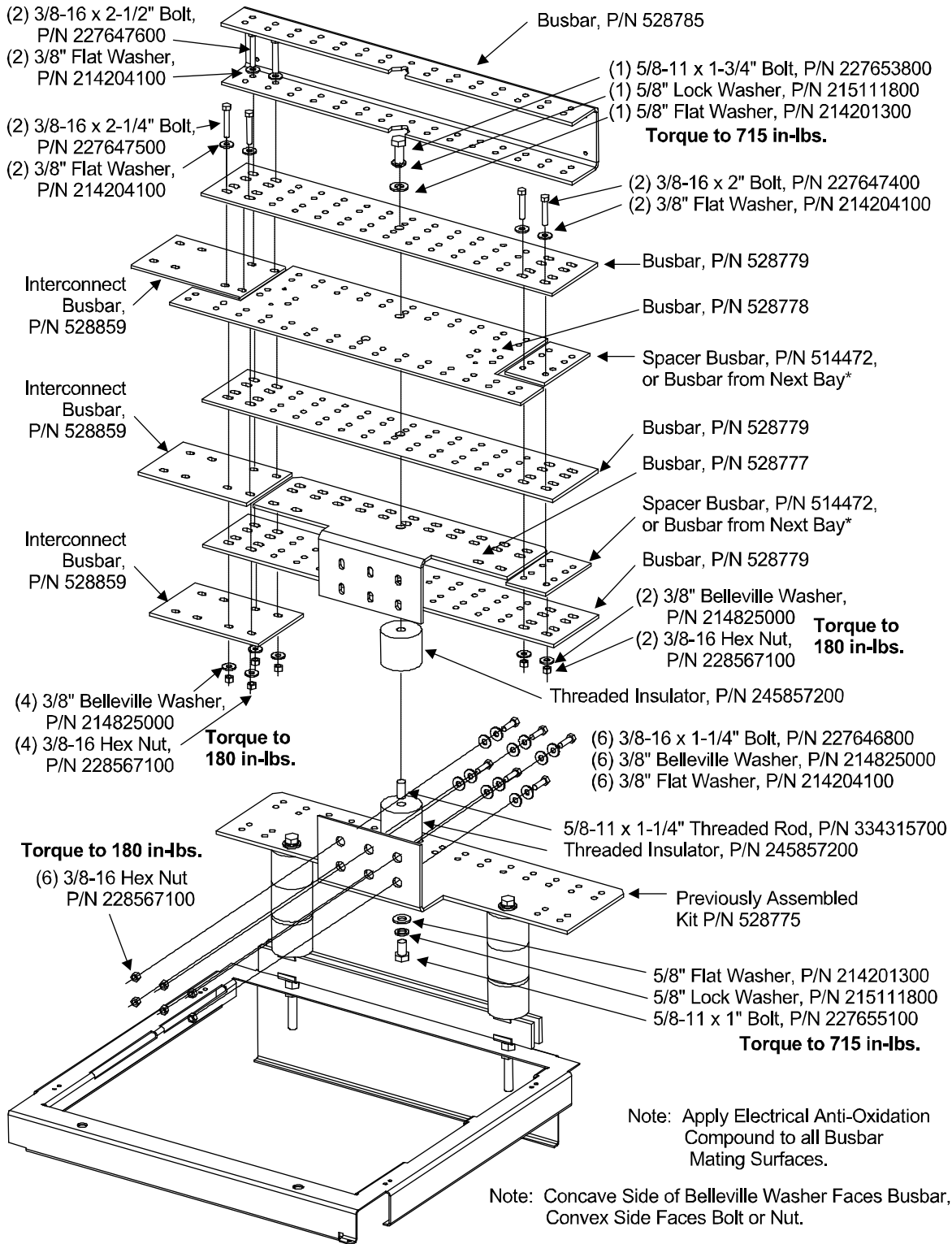
DANGER! Before performing this procedure, ensure that the power/distribution bay is COMPLETELY DISCONNECTED from all power sources.



NOTE! Apply electrical anti-oxidation compound to mating surfaces of busbars before connecting together.

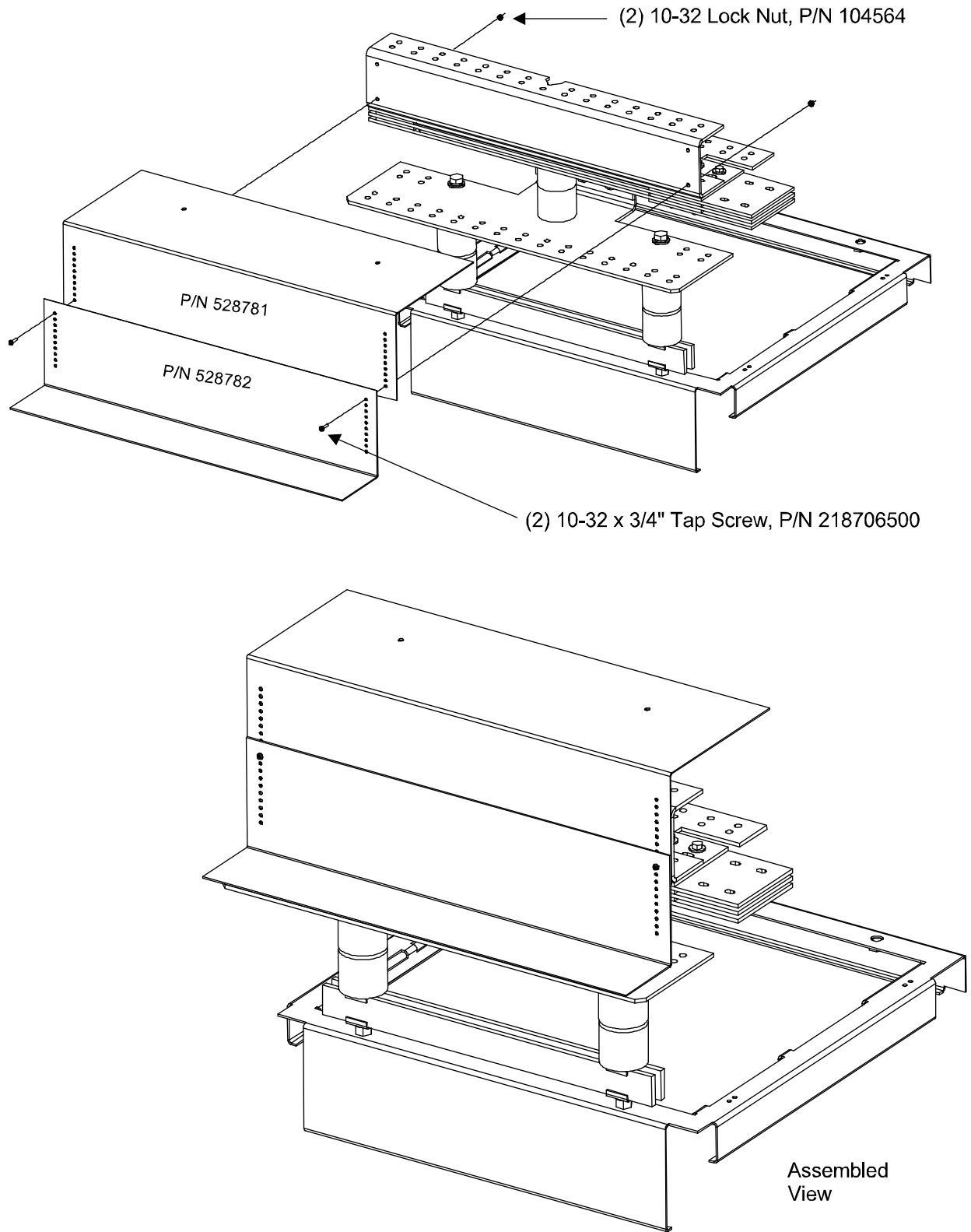
1. Assemble the busbar kit to the top of the bays as shown in **Figure 4.63** and **Figure 4.64**.

Figure 4.63 Distribution Only Bay External Top-Mount Ground (Load Return) Extension Busbar Assembly (P/N 528780)
Assembly Procedure Step 1



* Use "Spacer Busbars" on end bays or stand-alone bays.
 For multiple bays, 'sandwich' busbars of adjacent "Busbar Assemblies" together.

Figure 4.64 Distribution Only Bay External Top-Mount Ground (Load Return) Extension Busbar Assembly (P/N 528780)
Assembly Procedure Step 2



5 Installing Distribution Fuses and Circuit Breakers

5.1 Installing 218 Circuit Breakers, TPL Fuseholders, and Bullet Nose-Type Device Mounting Assemblies into Power/Distribution Bays



NOTE! Each distribution bus is divided into half. Each half **MUST** be populated with distribution devices from left-to-right, without skipping any distribution device mounting positions within each half.

Procedure

1. Orient the device over its mounting location as shown in **Figure 5.1**. Slide the device over the top and bottom mounting studs, and plug the device into the mating connector located on the bay. Ensure correct alignment of the mating pins as you plug the device in.
2. Place a Belleville lock washer and 3/8-16 nut on each bottom stud.
Hand-tighten.
3. Place a flat washer, lock washer, and 1/4-20 nut on each top stud.
Hand-tighten.
4. Torque the bottom 3/8-16 nuts to 180 in-lbs.
5. Torque the top 1/4-20 nuts to 84 in-lbs.
6. Install Load Lug Adapter plates as required. Refer to **Figure 5.2** for location and the numbering scheme for the load lug mounting locations. Refer to **Figure 5.5** and **Figure 5.6** for load lug adapter selection. Hardware build-up is 1/4 inch flat washer, 1/4 inch lock washer, and 1/4-20 nut. Torque to 84 in-lbs. **Note that Bullet Nose-Type devices do not require load lug adapter plates.**

5.2 Installing 218 Circuit Breakers and TPL Fuseholders into Distribution Only Bays



NOTE! Each distribution bus is divided into half, and each half **MUST** be populated with distribution devices as shown in the following illustrations, without skipping any distribution device mounting positions within each half.

Procedure

1. Orient the device over its mounting location as shown in **Figure 5.3**. Slide the device over the left and right mounting studs, and plug the device into the mating connector located on the bay. Ensure correct alignment of the mating pins as you plug the device in.
2. Place a Belleville lock washer and 3/8-16 nut on each inner stud.
Hand-tighten.
3. Place a flat washer, lock washer, and 1/4-20 nut on each outer stud.
Hand-tighten.
4. Torque the inner 3/8-16 nuts to 180 in-lbs.
5. Torque the outer 1/4-20 nuts to 84 in-lbs.
6. Install Load Lug Adapter plates as required. Refer to **Figure 5.4** for location and the numbering scheme for the load lug mounting locations. Refer to **Figure 5.5** through **Figure 5.6** for load lug adapter selection and installation details. **Note that**

1-pole devices do not require load lug adapter plates. Note that Bullet Nose-Type devices CANNOT be used in Distribution Only Bays.

5.3 Installing TPL Fuses

Refer to **Figure 5.7**.

Procedure

1. Remove the fuseholder portion from the mounted fuseholder body by grasping its handle and pulling it straight out. Install the TPL fuse into the fuseholder portion. Secure the fuse with the flat washer, lock washer, and nut provided. Recommended torque is 168 in-lbs. When done, push the fuseholder portion securely back into the mounted fuseholder body.
2. Ensure an alarm fuse is installed in the GMT-type fuseholder located adjacent to the TPL fuseholder. The alarm fuse should be a Bussmann GMT 18/100 ampere alarm fuse. Vertiv P/N 248610301.
3. Ensure a safety fuse cover is installed on the GMT alarm fuse. Vertiv P/N 248898700.

5.4 Installing TLS/TPS Fuses

Refer to **Figure 5.7** and **Figure 5.8**.

Procedure

1. Orient the Bullet Nose-Type Fuseholder over its mounting position and firmly press to seat the bullet-type connectors.
2. Remove the fuseholder portion from the mounted fuseholder body by pulling it straight out. Install the TLS/TPS fuse into the fuseholder. When done, push the fuseholder portion back into the mounted fuseholder body.
3. Ensure an alarm fuse is installed in the GMT-type fuseholder provided on the mounted fuseholder body. The alarm fuse should be a Bussmann GMT 18/100 ampere alarm fuse. Vertiv P/N 248610301.
4. Ensure a safety fuse cover is installed on the GMT alarm fuse. Vertiv P/N 248898700.

5.5 Installing Bullet Nose-Type Circuit Breakers

Refer to **Figure 5.7** and **Figure 5.8**.

Power/Distribution Bay

1. Orient the circuit breaker over its mounting position with the ON position at top and firmly press to seat the bullet-type connectors.

Distribution Only Bay

Note that Bullet Nose-Type devices CANNOT be used in Distribution Only Bays.

5.6 Installing an Optional Bullet Nose-Type 10-Position GMT Fuse Module

Refer to the procedure “Installing and Wiring an Optional Bullet Nose-Type 10-Position GMT Fuse Module (P/N 509128)” on page 149.

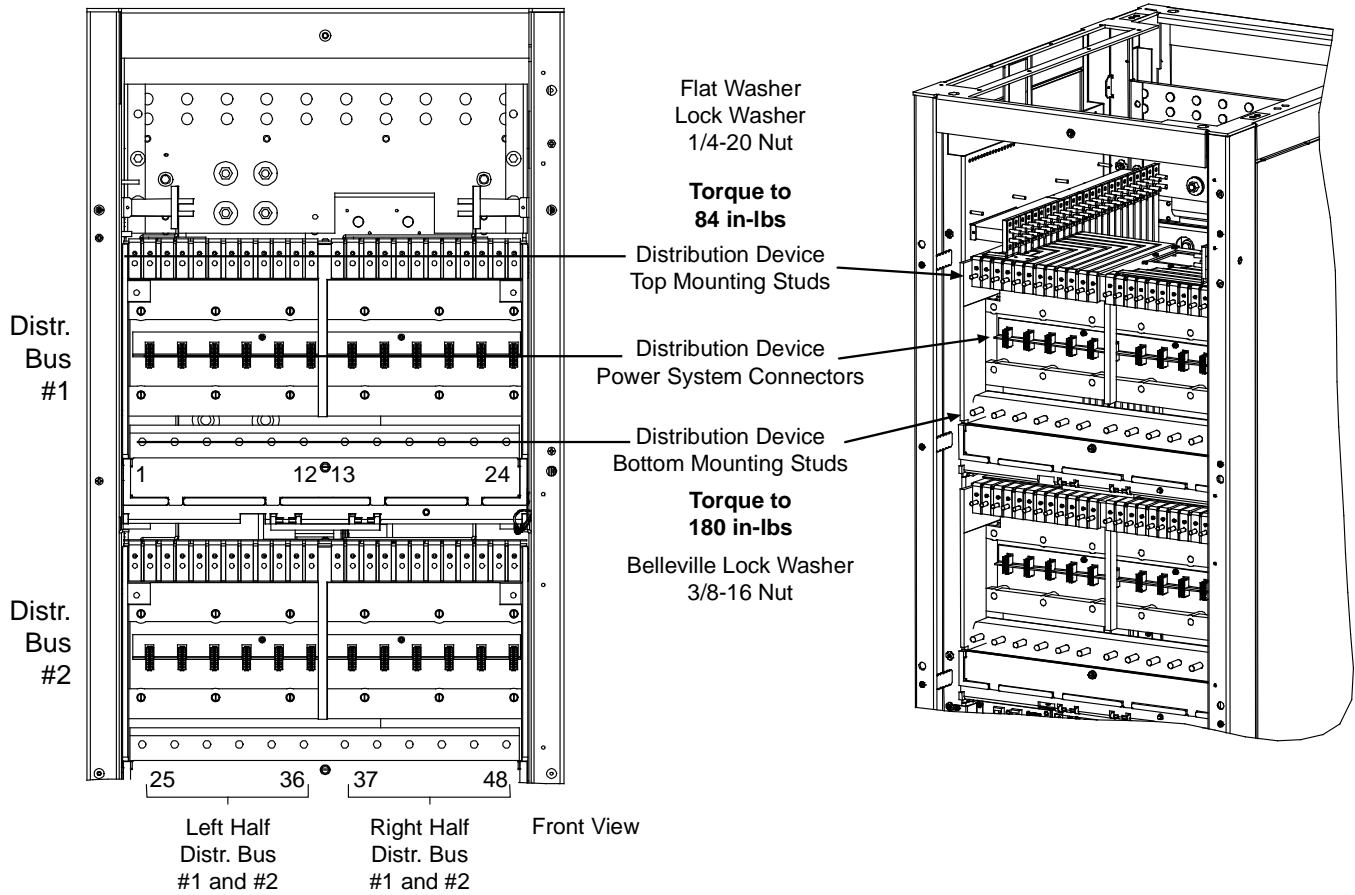
5.7 Storing Spare Fuses

Spare fuses may be stored in holders provided inside the bay, behind the distribution bus monitoring circuit card hinged panels.

5.8 Recording Fuse and Circuit Breaker Sizes

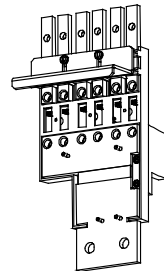
Record all fuse and circuit breaker sizes installed on the cards provided on the distribution bus monitoring circuit card hinged panels.

Figure 5.1 Installing 218 Circuit Breakers, TPL Fuseholders, and Bullet Nose-Type Device Mounting Assemblies into Power/Distribution Bays



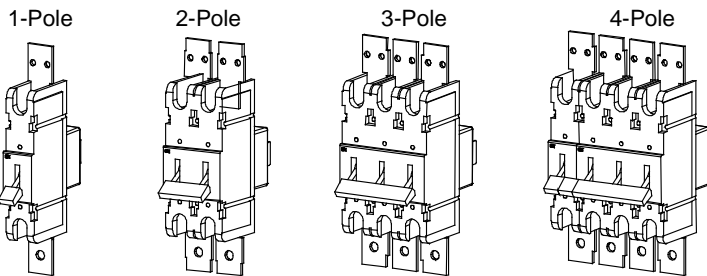
Bullet Nose-Type Device Mounting Assembly

3-Pole



Note: Each half of each bus MUST be populated with distribution devices from left-to-right, without skipping any distribution device mounting positions within each half.

218 Circuit Breakers



TPL Fuseholders

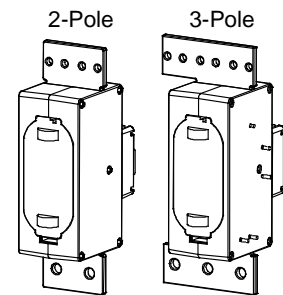
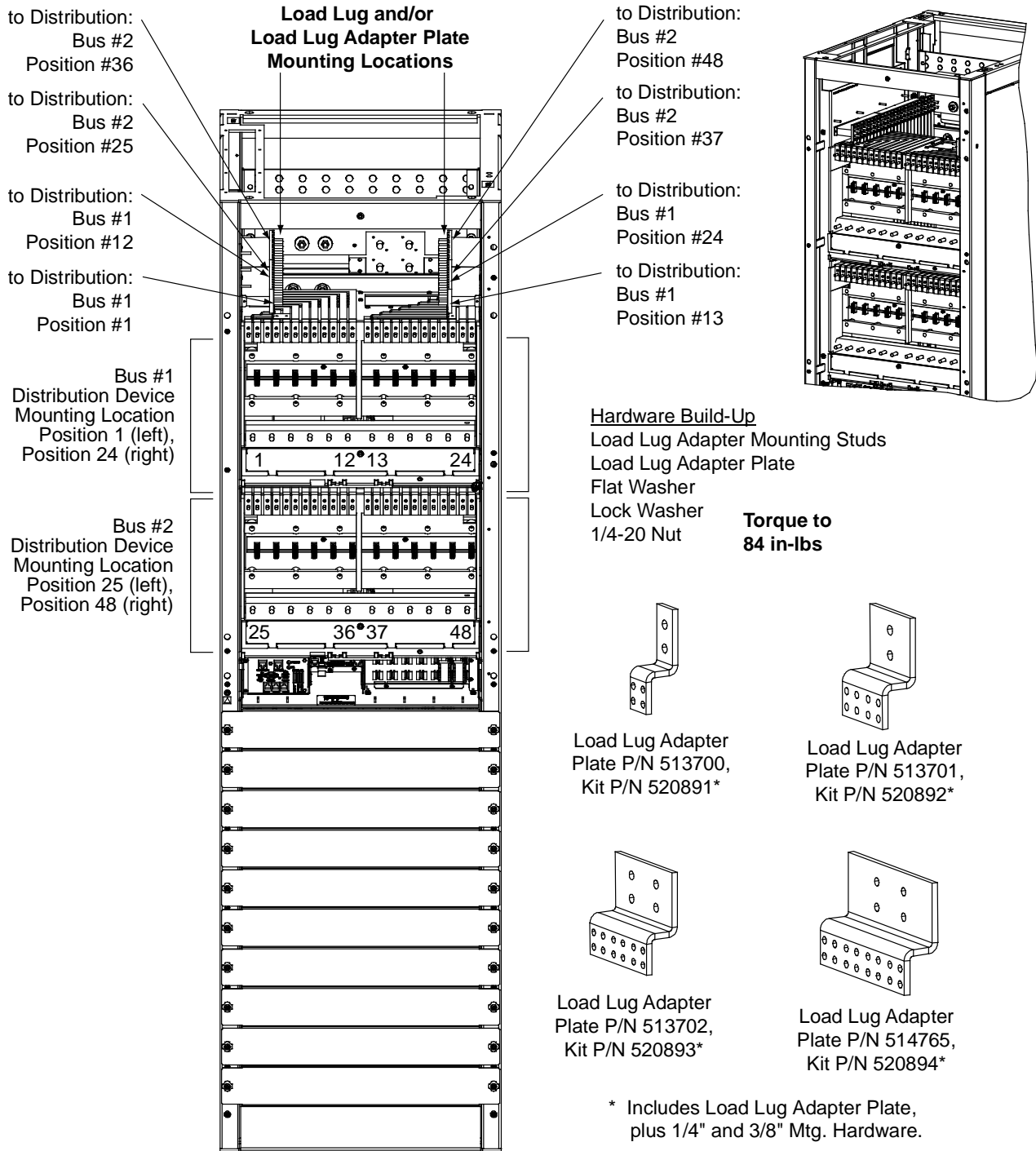


Figure 5.2 Installing Load Lug Adapter Plates into Power/Distribution Bays

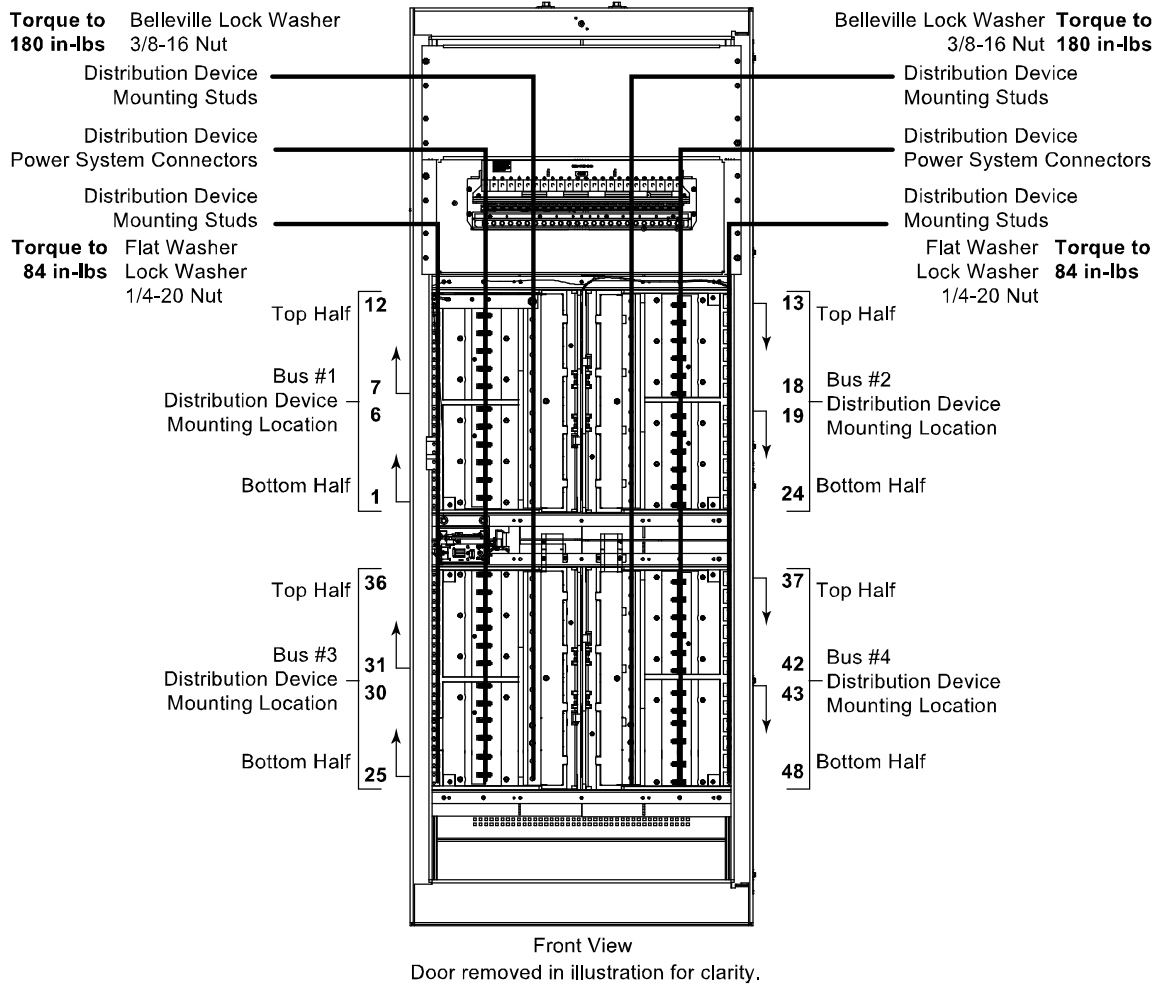


Front View

REFER TO DISTRIBUTION DEVICES ILLUSTRATIONS FOR PROPER LOAD LUG ADAPTER SELECTION

NOTE THAT BULLET NOSE-TYPE DEVICE MOUNTING ASSEMBLIES DO NOT REQUIRE LOAD LUG ADAPTER PLATES

Figure 5.3 Installing 218 Circuit Breakers and TPL Fuseholders into Distribution Only Bays



Note: On the left side, each half of each bus **MUST** be populated with distribution devices from bottom-to-top, without skipping any distribution device mounting positions within each half. (Arrows indicate starting position in each half.)

Note: On the right side, each half of each bus **MUST** be populated with distribution devices from top-to-bottom, without skipping any distribution device mounting positions within each half. (Arrows indicate starting position in each half.)

This allows automatic monitoring of each position and allow the controller to located all distribution positions.

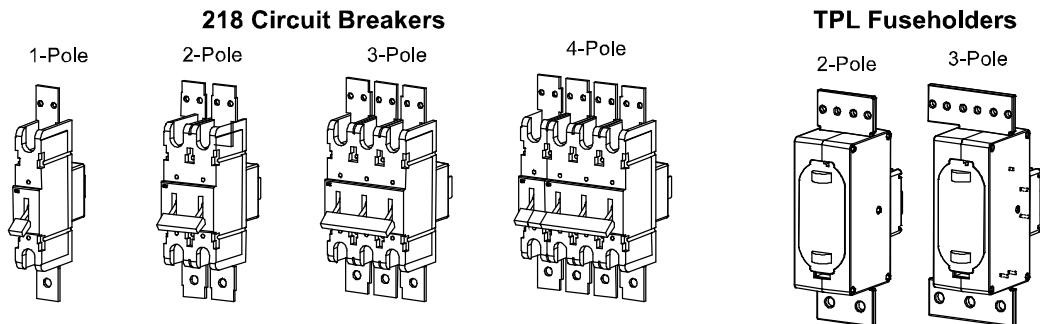


Figure 5.4 Installing Load Lug Adapter Plates into Distribution Only Bays (cont'd on next page)

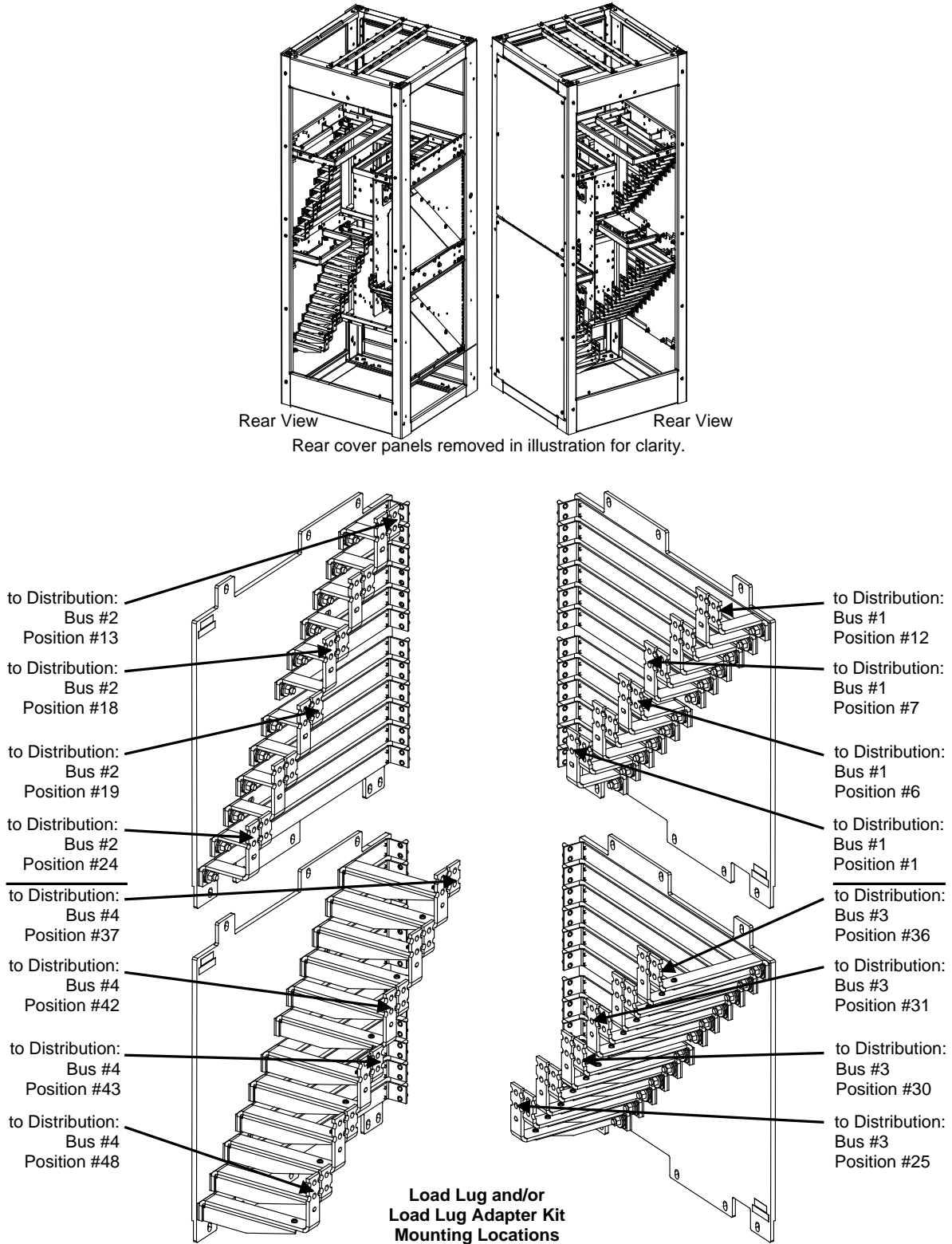
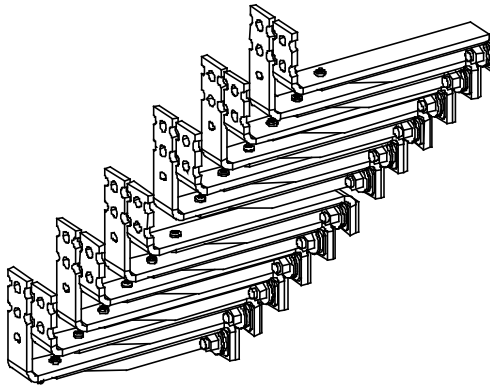
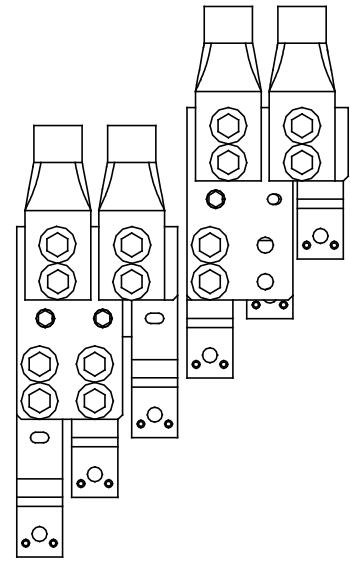


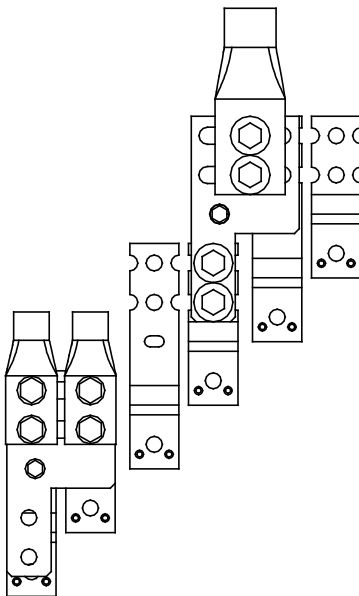
Figure 5.4 Installing Load Lug Adapter Plates into Distribution Only Bays (cont'd from previous page, cont'd on next page)



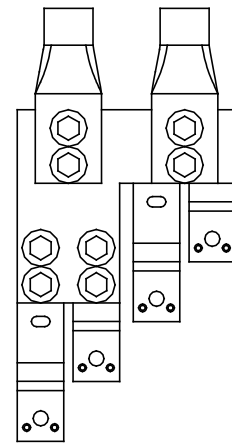
1-Position Devices
(Load Busbars with NO
Lug Adapters Installed)



3-Position
Lug Adapter Kit
P/N 529131



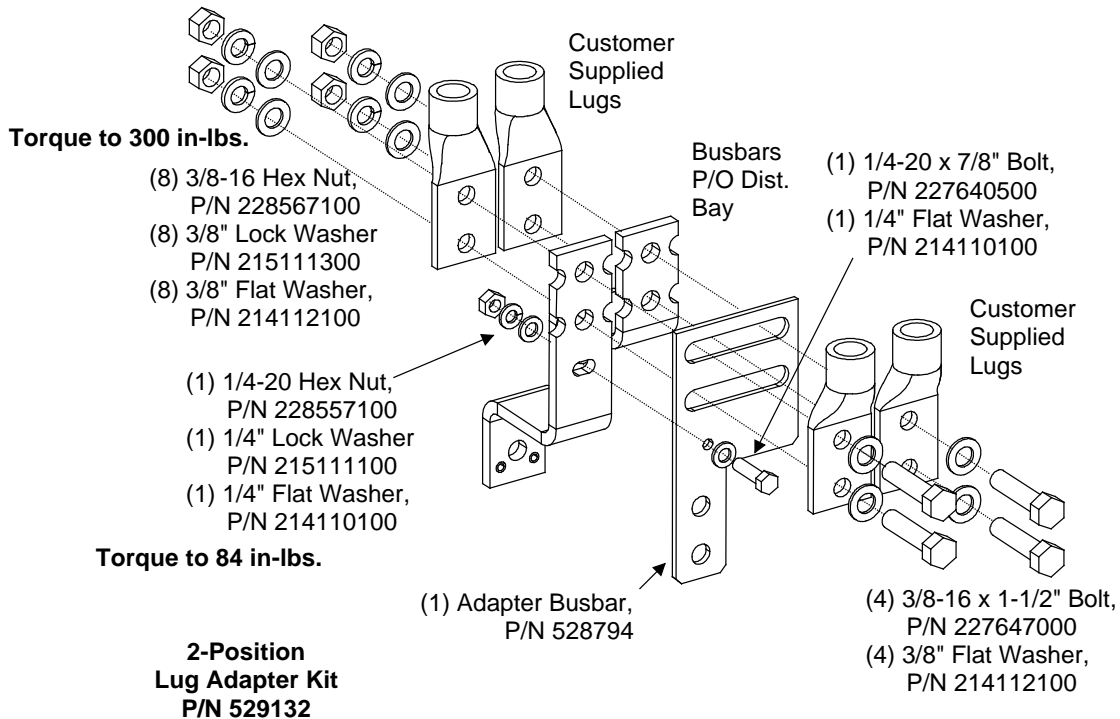
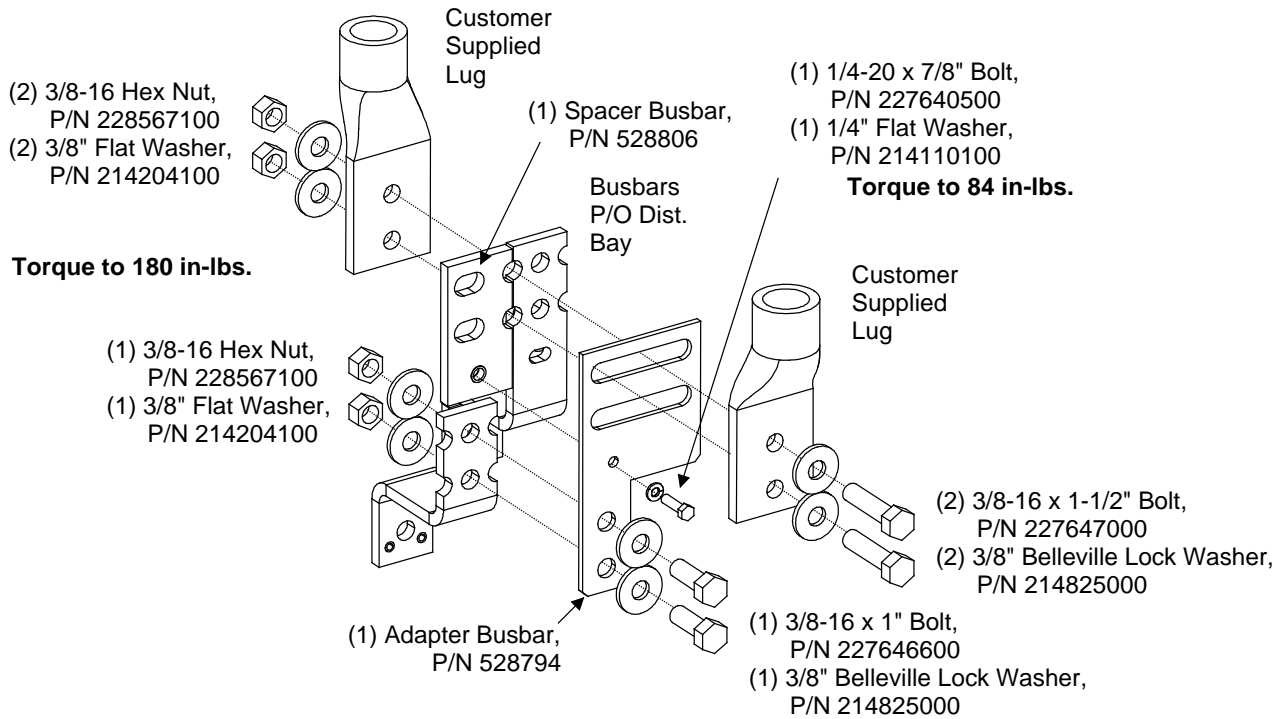
2-Position
Lug Adapter Kit
P/N 529132



4-Position
Lug Adapter Kit
P/N 534420

**NOTE THAT 1-POLE 218 CIRCUIT BREAKERS
DO NOT REQUIRE LOAD LUG ADAPTER PLATES**

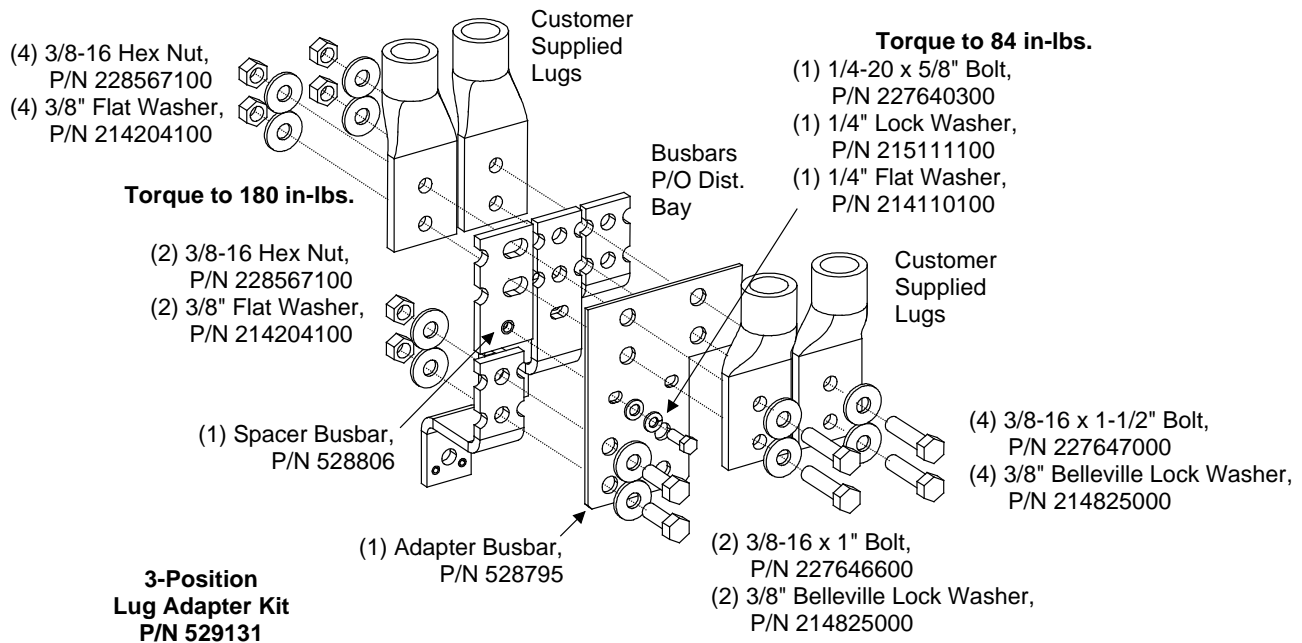
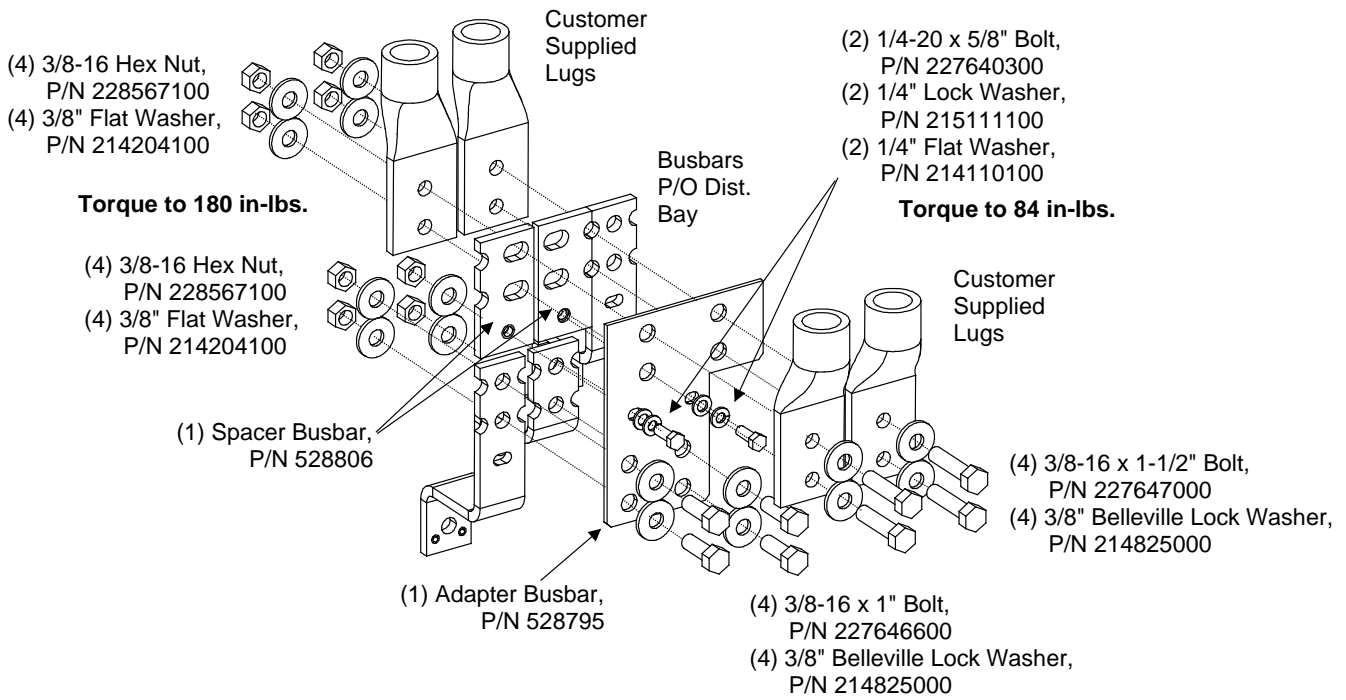
Figure 5.4 Installing Load Lug Adapter Plates into Distribution Only Bays (cont'd from previous page, cont'd on next page)



Note: Apply Electrical Anti-Oxidation Compound to all Busbar Mating Surfaces.

Note: Concave Side of Belleville Washer Faces Busbar, Convex Side Faces Bolt or Nut.

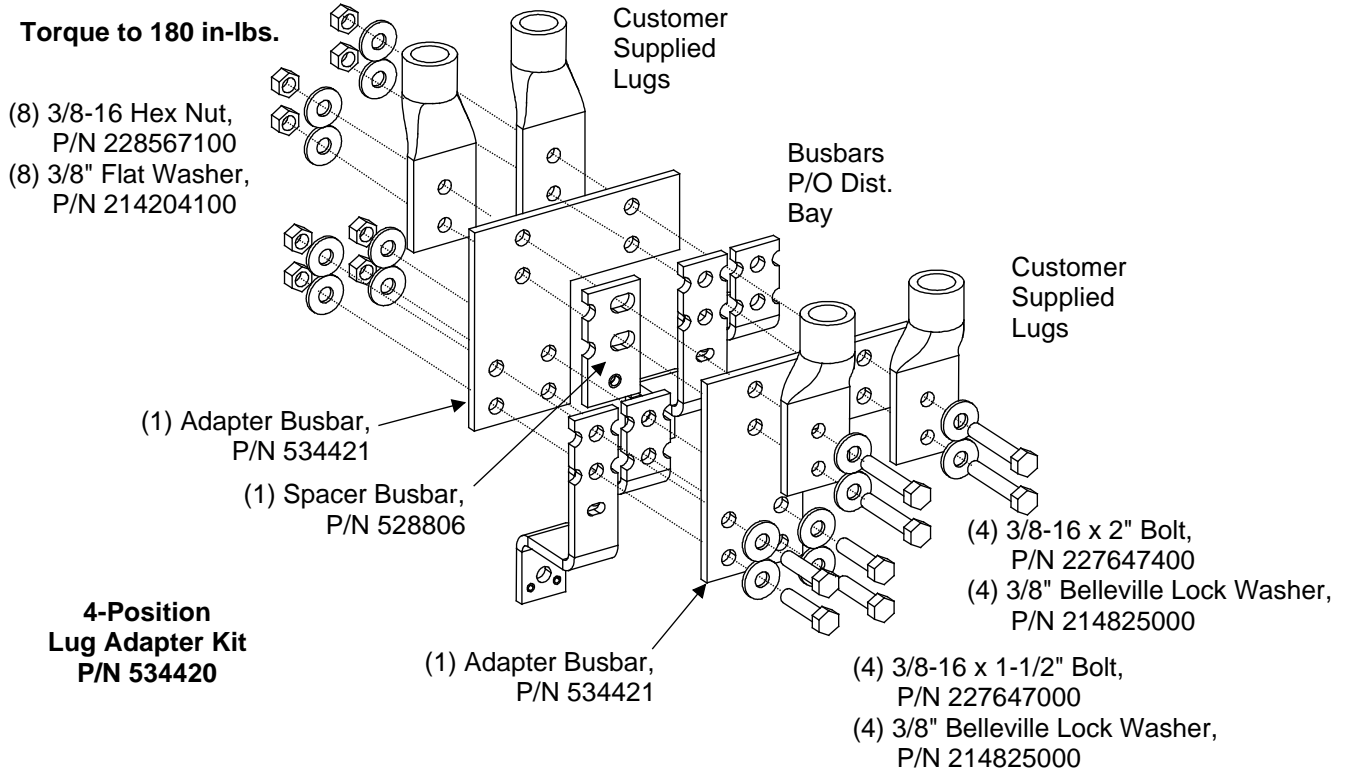
Figure 5.4 Installing Load Lug Adapter Plates into Distribution Only Bays (cont'd from previous page, cont'd on next page)



Note: Apply Electrical Anti-Oxidation Compound to all Busbar Mating Surfaces.

Note: Concave Side of Belleville Washer Faces Busbar, Convex Side Faces Bolt or Nut.

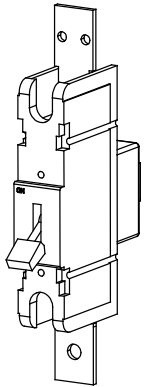
Figure 5.4 Installing Load Lug Adapter Plates into Distribution Only Bays (cont'd from previous page)



Note: Apply Electrical Anti-Oxidation Compound to all Busbar Mating Surfaces.

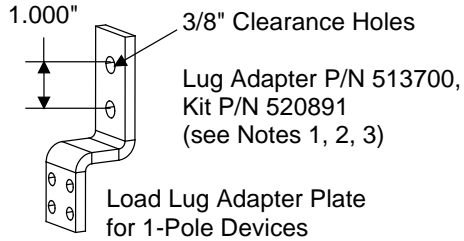
Note: Concave Side of Belleville Washer Faces Busbar, Convex Side Faces Bolt or Nut.

Figure 5.5 218 Circuit Breakers Lug Adapter Kits (cont'd on next page)



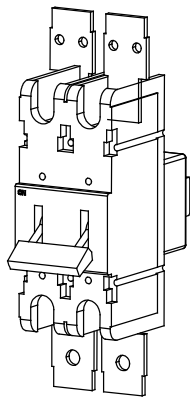
1-Pole 218 Circuit Breaker Assemblies

**Lug Adapter Kits
Power/Distribution Bays**



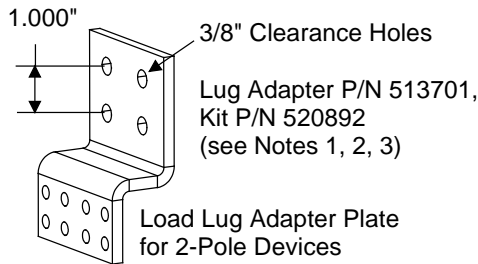
**Lug Adapter Kits
Distribution Only Bays**

NO LUG ADAPTER KITS
REQUIRED WHEN USED IN
DISTRIBUTION ONLY BAYS

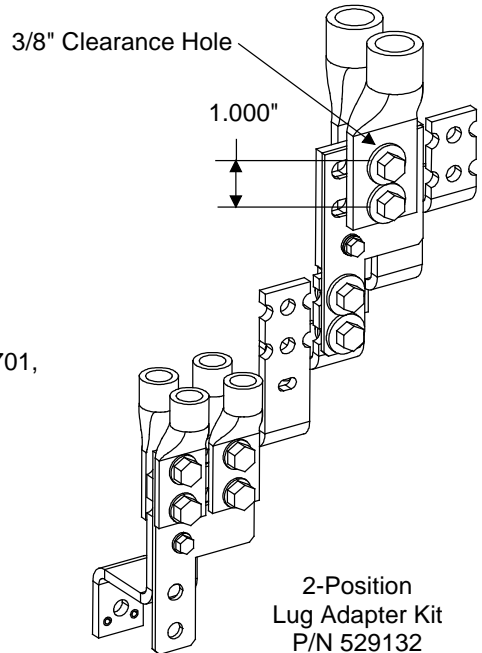


2-Pole 218 Circuit Breaker Assemblies

**Lug Adapter Kits
Power/Distribution Bays**



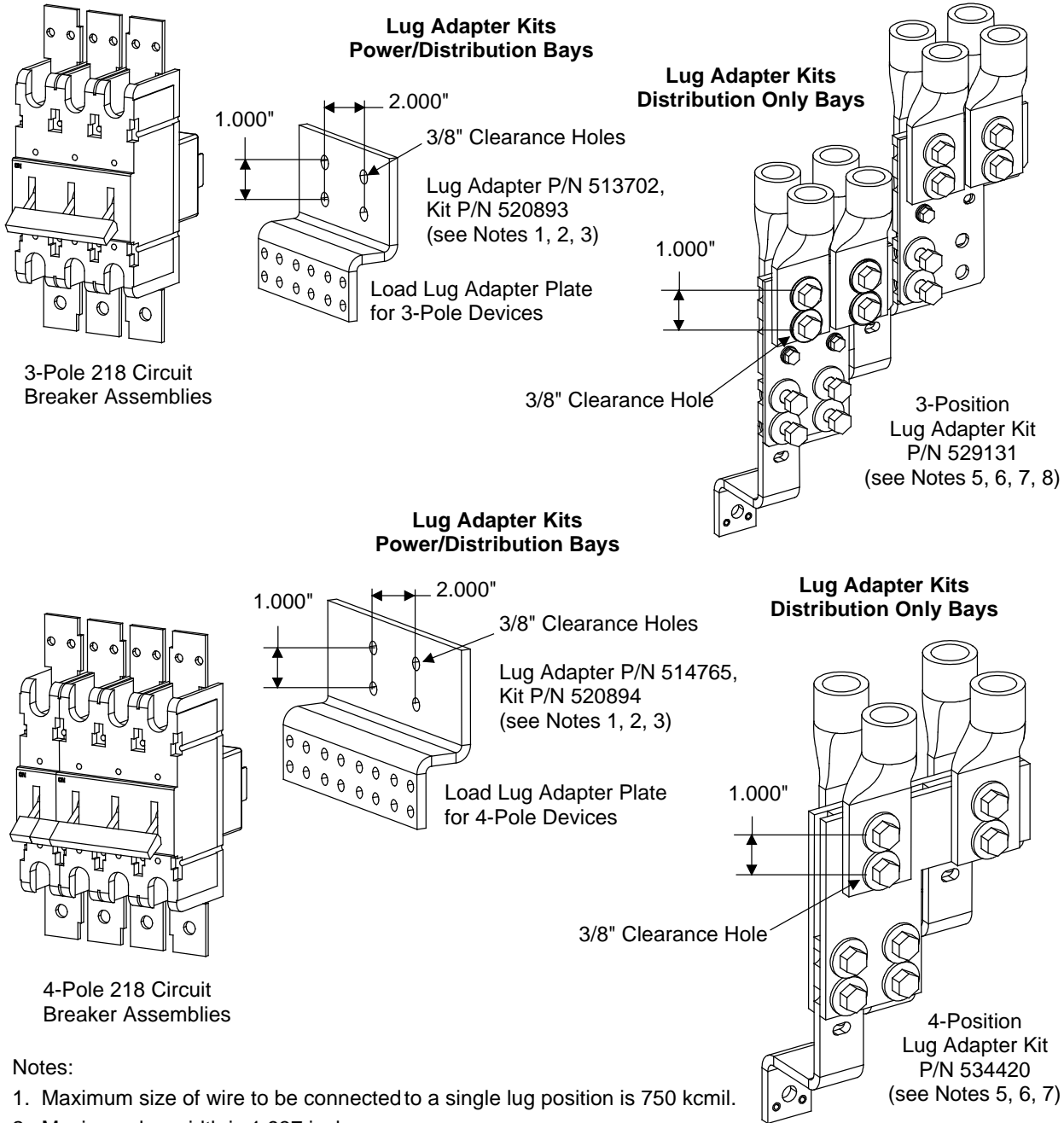
**Lug Adapter Kits
Distribution Only Bays**



Notes:

1. Maximum size of wire to be connected to a single lug position is 750 kcmil.
2. Maximum lug width is 1.937 inches.
3. Kit includes Load Lug Adapter Plate, plus 1/4" and 3/8" mtg. hardware.
4. Lug adapter accepts a maximum of (2) 750 kcmil or (4) 350 kcmil lugs.
5. Lug adapter accepts a maximum of (4) 750 kcmil lugs.
6. Lugs are not part of the kit, shown for illustration only.
7. Bay busbars are not part of the kit, shown for illustration only.
8. Two (2) kits shown for illustration of the kit installed on busbars with tops even with each other and staggered.

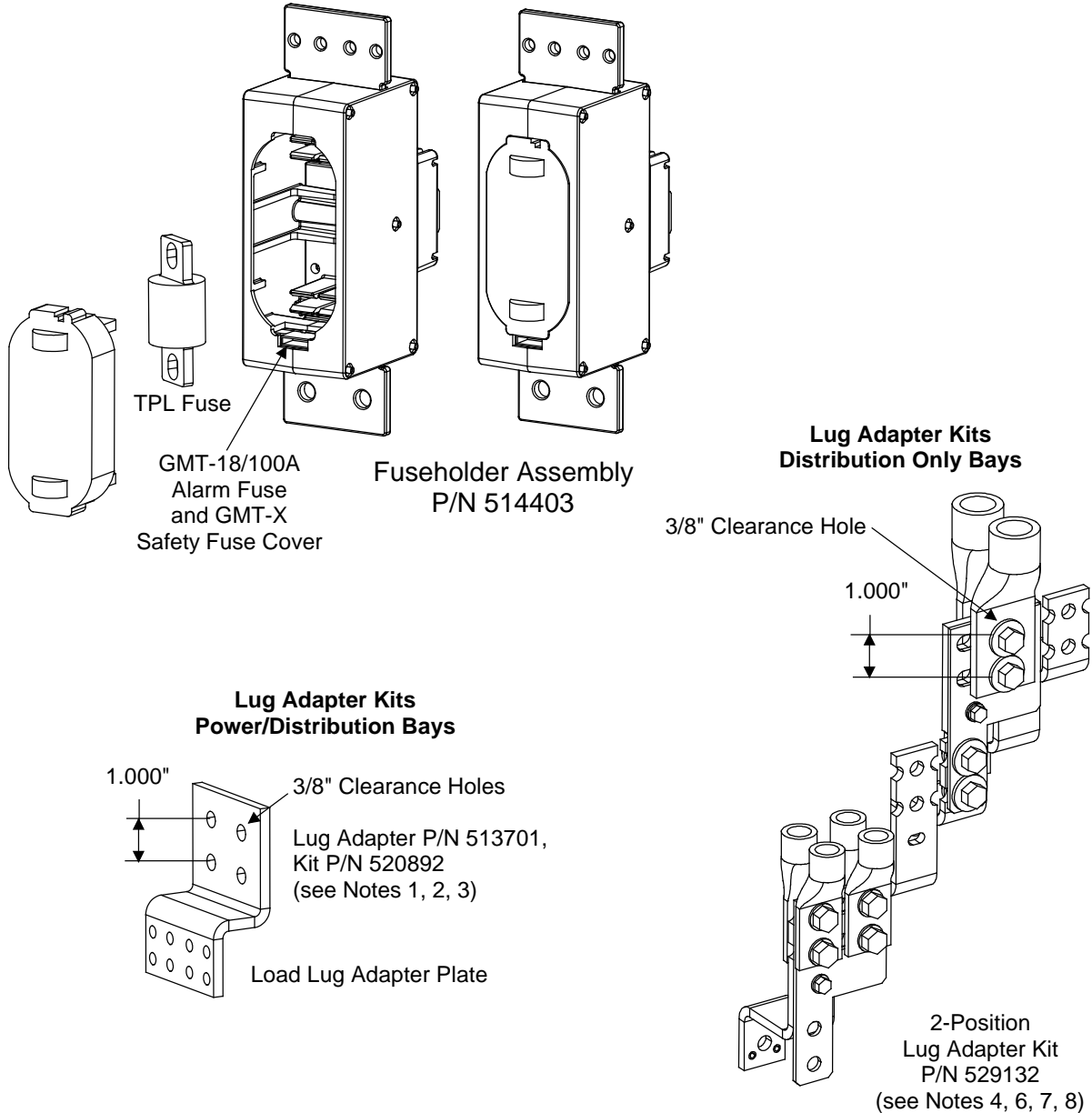
Figure 5.5 218 Circuit Breakers Lug Adapter Kits (cont'd from previous page)



Notes:

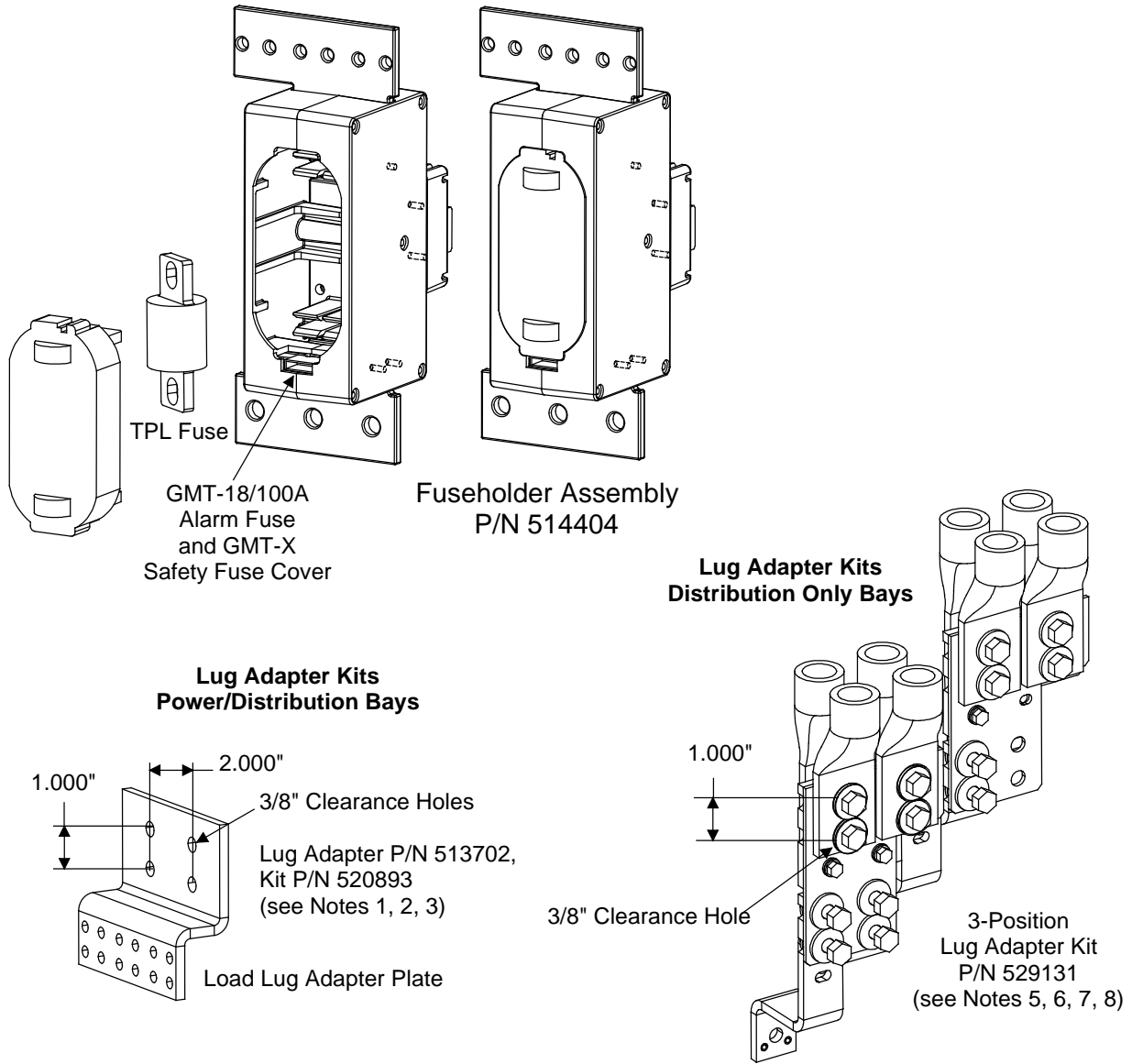
1. Maximum size of wire to be connected to a single lug position is 750 kcmil.
2. Maximum lug width is 1.937 inches.
3. Kit includes Load Lug Adapter Plate, plus 1/4" and 3/8" mtg. hardware.
4. Lug adapter accepts a maximum of (2) 750 kcmil or (4) 350 kcmil lugs.
5. Lug adapter accepts a maximum of (4) 750 kcmil lugs.
6. Lugs are not part of the kit, shown for illustration only.
7. Bay busbars are not part of the kit, shown for illustration only.
8. Two (2) kits shown for illustration of the kit installed on busbars with tops even with each other and staggered.

Figure 5.6 TPL Fuses Lug Adapter Kits (cont'd on next page)

**Notes:**

1. Maximum size of wire to be connected to a single lug position is 750 kcmil.
2. Maximum lug width is 1.937 inches.
3. Kit includes Load Lug Adapter Plate, plus 1/4" and 3/8" mtg. hardware.
4. Lug adapter accepts a maximum of (2) 750 kcmil or (4) 350 kcmil lugs.
5. Lug adapter accepts a maximum of (4) 750 kcmil lugs.
6. Lugs are not part of the kit, shown for illustration only.
7. Bay busbars are not part of the kit, shown for illustration only.
8. Two (2) kits shown for illustration of the kit installed on busbars with tops even with each other and staggered.

Figure 5.6 TPL Fuses Lug Adapter Kits (cont'd from previous page)



Notes:

1. Maximum size of wire to be connected to a single lug position is 750 kcmil.
2. Maximum lug width is 1.937 inches.
3. Kit includes Load Lug Adapter Plate, plus 1/4" and 3/8" mtg. hardware.
4. Lug adapter accepts a maximum of (2) 750 kcmil or (4) 350 kcmil lugs.
5. Lug adapter accepts a maximum of (4) 750 kcmil lugs.
6. Lugs are not part of the kit, shown for illustration only.
7. Bay busbars are not part of the kit, shown for illustration only.
8. Two (2) kits shown for illustration of the kit installed on busbars with tops even with each other and staggered.

Figure 5.7 Installing TPL Fuses, TLS/TPS Fuses, and Bullet Nose-Type Circuit Breakers

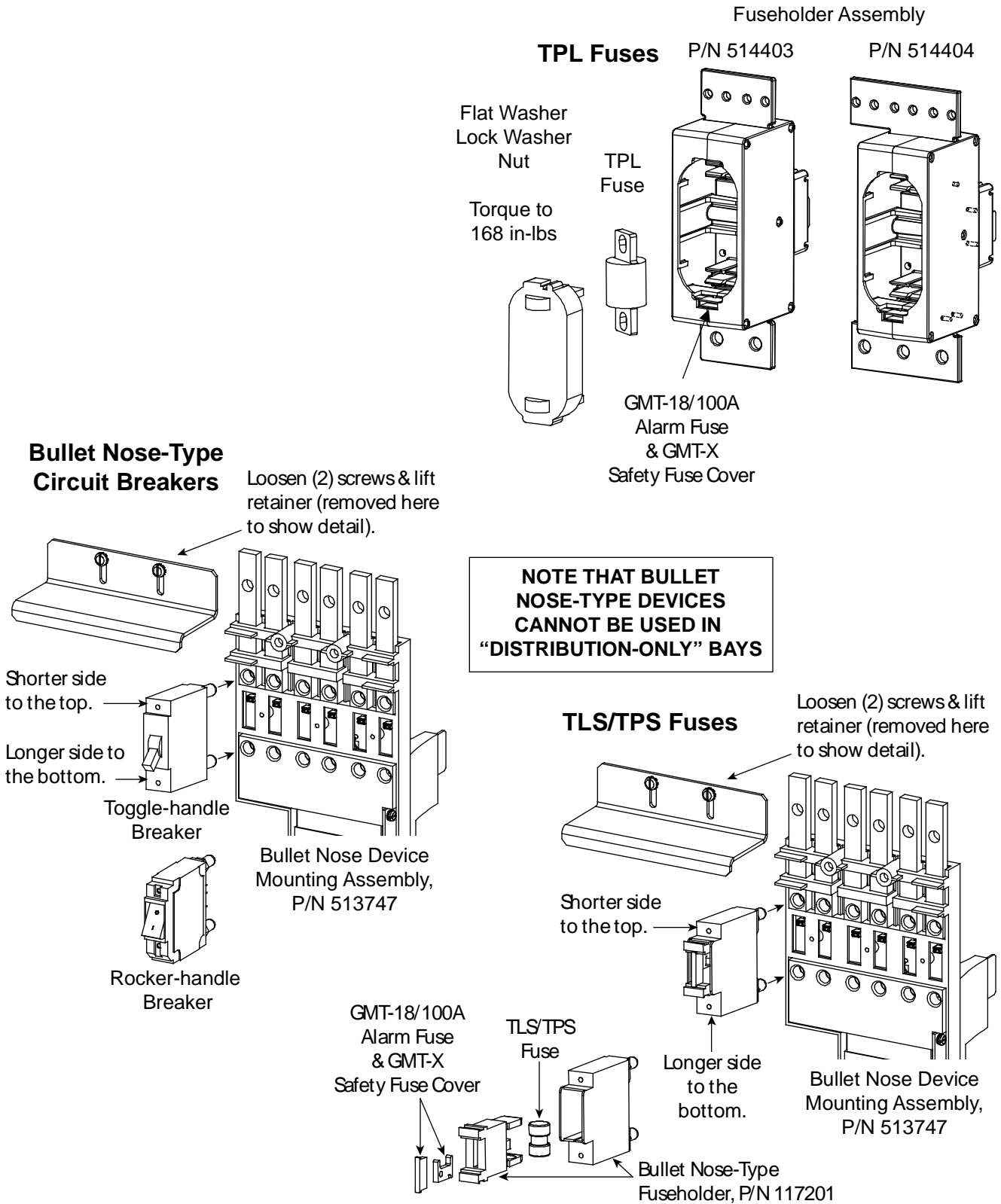
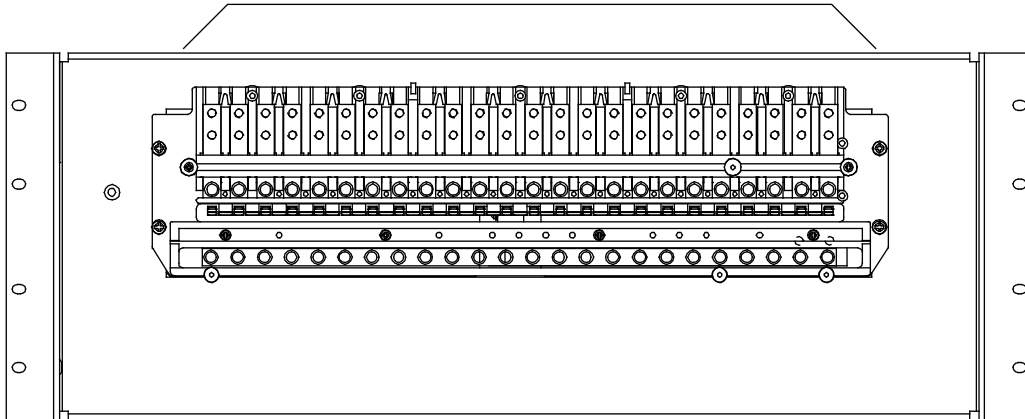


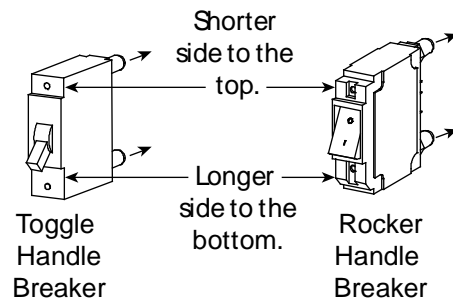
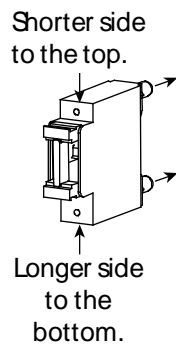
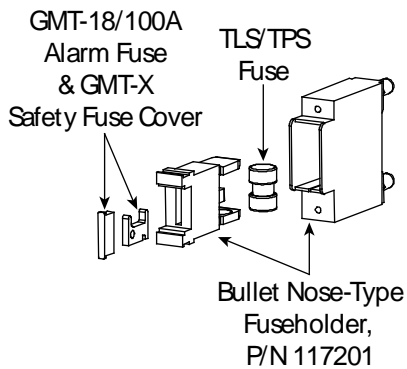
Figure 5.8 Installing TLS/TPS Fuses and Bullet Nose-Type Circuit Breakers (List C)

Note: Load leads are connected to load busbars. These busbars provide 1/4-20 threaded holes on 5/8" centers for installation of customer provided two-hole lugs. Customer must provide lug mounting bolts and additional hardware. Bolt length: 3/4".



TLS/TPS Fuses

Bullet Nose-Type Circuit Breakers



6 Making Switch and Jumper Settings

6.1 Switch Settings on IB2 and EIB Interface Boards

The IB2 and EIB installed in each primary power/distribution bay and primary power only bay contains switch SW1. Dip Switch SW1 on the IB2 and EIB board is used to set the communications address for this board. Refer to **Figure 6.1** for IB2 and EIB location. Refer to **Figure 6.2** for IB2 switch SW1 location. Refer to **Figure 6.3** for EIB switch SW1 location. Refer to **Table 6.1** for SW1 settings.

Perform the following procedure to verify the factory settings. This procedure can also be used to make adjustments on a replacement circuit card.

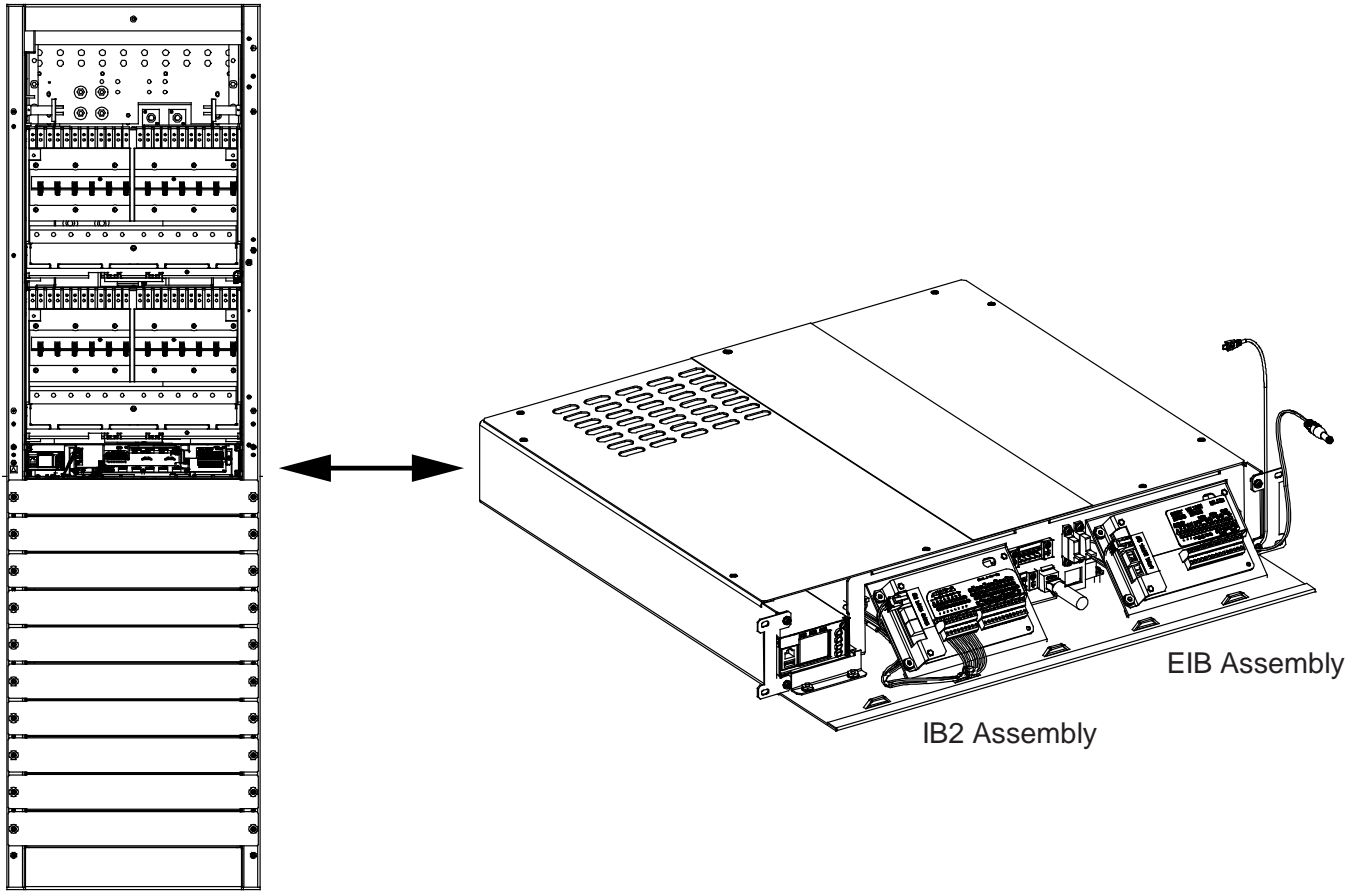
Procedure

1. Ensure SW1 is set per **Table 6.1**. Refer to **Figure 6.2** and **Figure 6.3** for location.

Table 6.1 IB2 and EIB Interface Board Switch Settings

Setting	DIP Switch SW1	
	1	2
IB2 in Primary Bay	OFF	OFF
EIB in Primary Bay	OFF	OFF

Figure 6.1 IB2 and EIB Interface Board Location



Primary Power/Distribution Bay
Primary Power Only Bay Similar

Front door removed in illustration for clarity only.

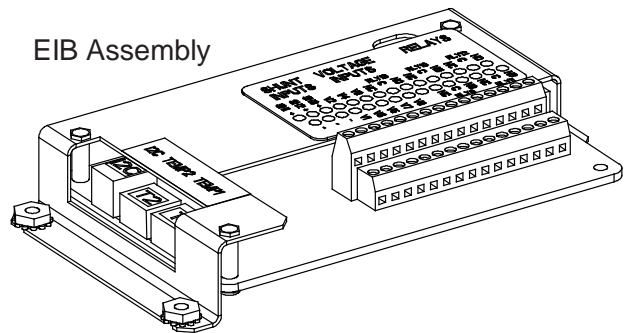
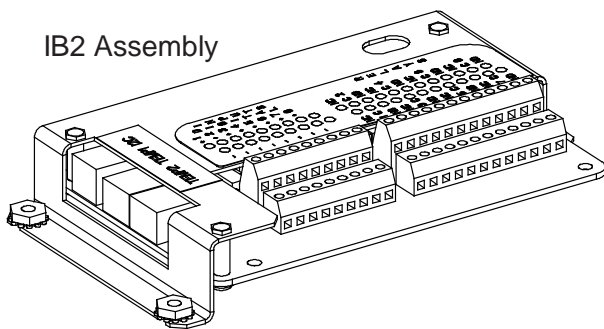
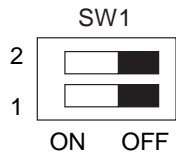
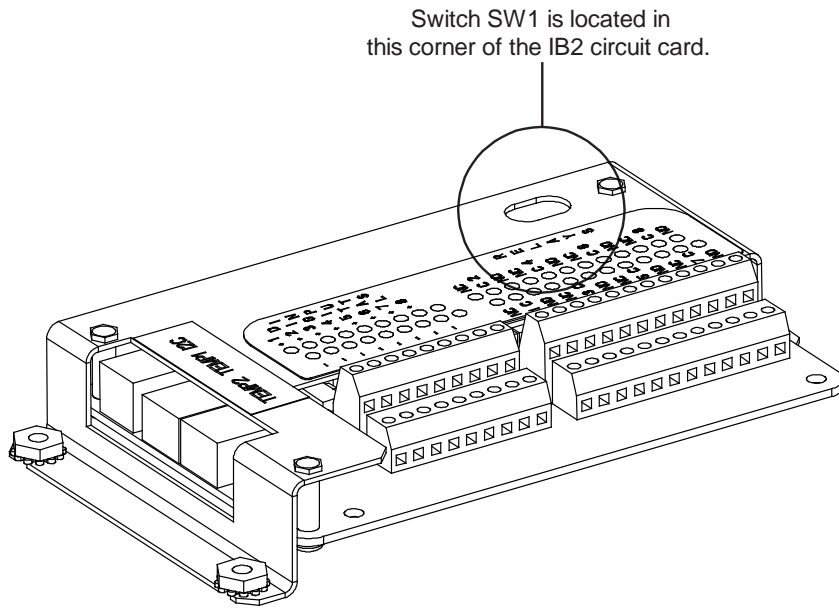


Figure 6.2 IB2 Interface Board Switch Settings



Setting	DIP Switch SW1	
	1	2
IB2	OFF	OFF

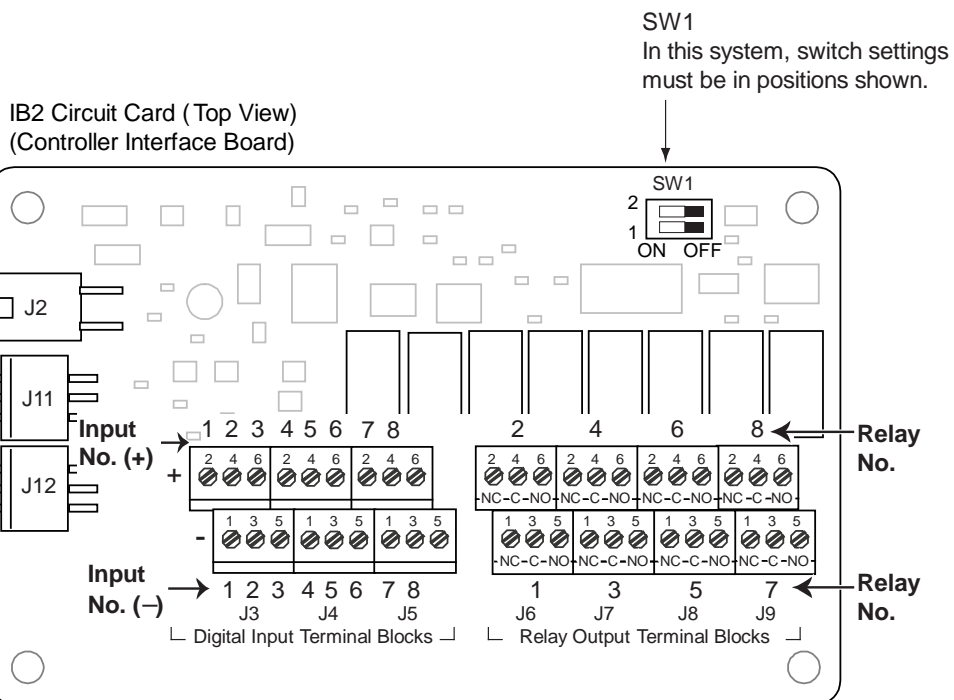
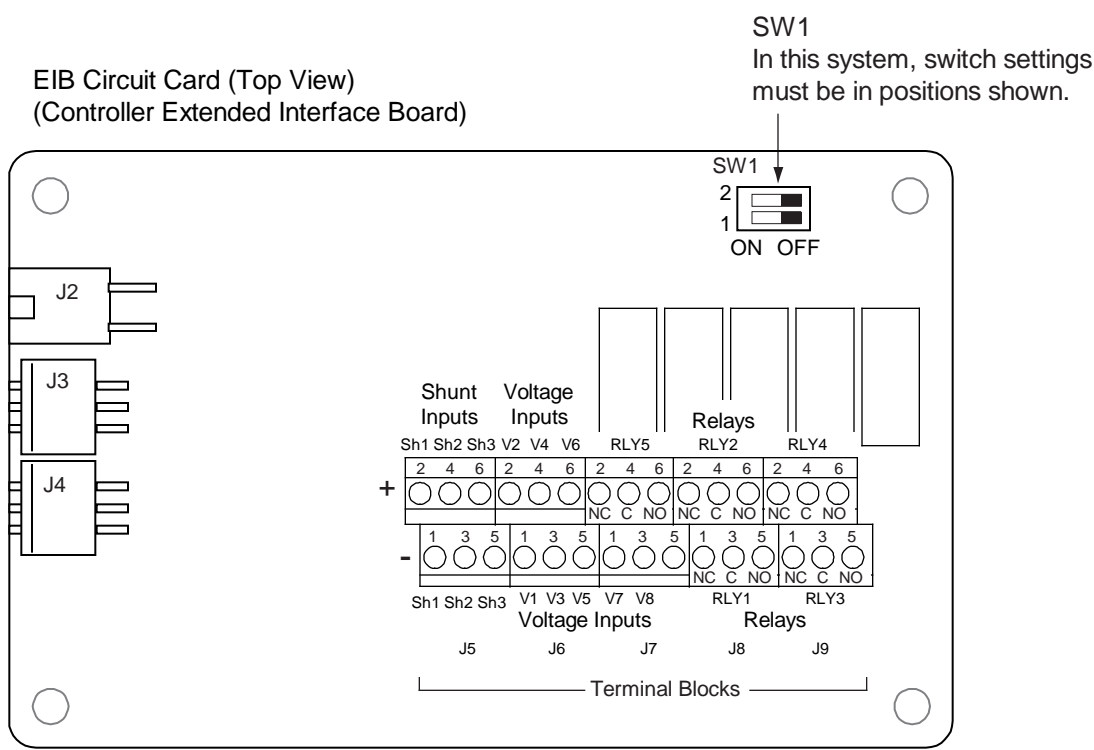
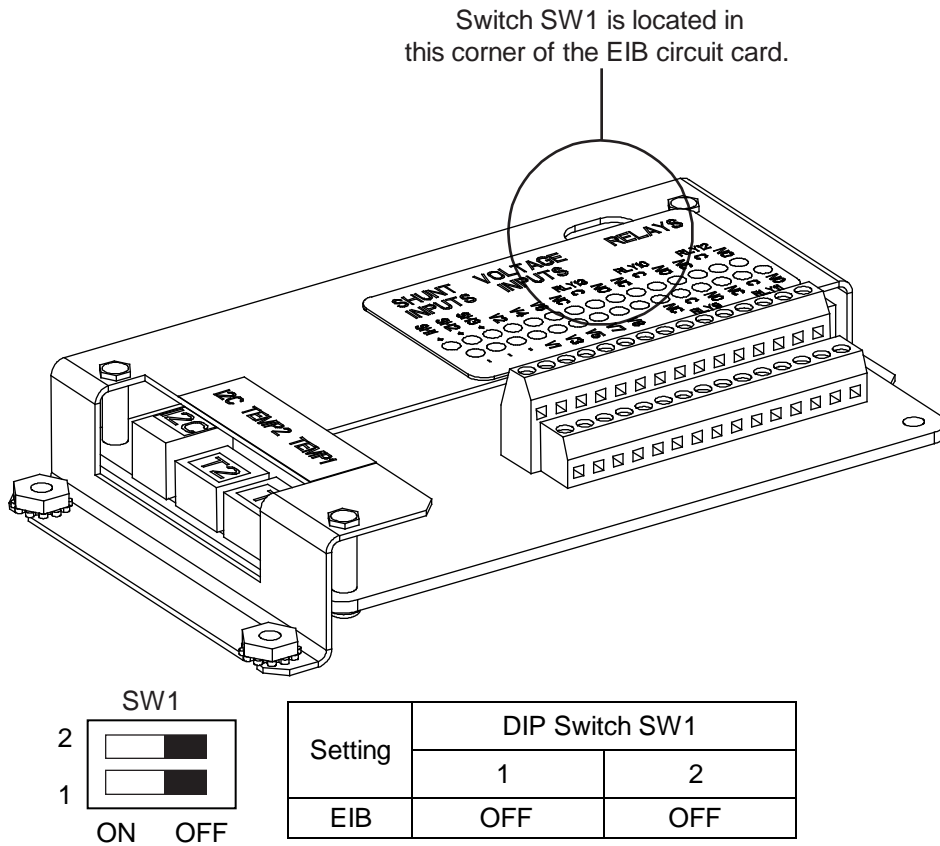


Figure 6.3 EIB Extended Interface Board Switch Settings



6.2 Switch Settings on SM-DUE

The SM-DUE installed in each secondary power/distribution bay and secondary power only bay contains DIP switch SW1. Dip switch SW1 on the SM-DUE is used for parameter settings.

Procedure

1. Set DIP switch SW1 on each SM-DUE per site requirements. Refer to **Figure 6.4** for SM-DUE and switch SW1 location. Refer to **Table 6.2** for switch settings.



NOTE! Set each SM-DUE to a different communications address.

Table 6.2 SM-DUE Switch Settings

Communication Address (Use Switch 1, 2, and 3 of SW1)			Function Descriptions
1	2	3	
Off	Off	Off	SM-DUE #1 (Default Setting)
Off	Off	On	SM-DUE #2
Off	On	Off	SM-DUE #3
Off	On	On	SM-DUE #4
On	Off	Off	SM-DUE #5
On	Off	On	SM-DUE #6
On	On	Off	SM-DUE #7
On	On	On	SM-DUE #8
Baud Rate for Serial Port Communication (Use Switch 4 of SW1)			Function Descriptions
4			
Off			19200 (Default Setting)
On			9600
Parameter of Shunt Setting Configured by Hardware or Software (Use Switch 5 of SW1)			Function Descriptions
5			
Off			Shunt parameter is set through software. (Default Setting)
On			Shunt parameter is set through DIP switch.
Shunt Voltage (Use Switch 6 of SW1)			Function Descriptions
6			
Off			25 mV (Default Setting)
On			50 mV
Shunt Current (Use Switch 7 and 8 of SW1)			Function Descriptions
7 8			
Off	Off		500 A (Default Setting)
Off	On		1000 A
On	Off		1500 A
On	On		2000 A

6.3 Jumper Settings on SM-DUE

The SM-DUE installed in each secondary power/distribution bay and secondary power only bay contains thirty (30) 2-pin jumpers. Three (3) for each of the ten (10) SM-DUE analog inputs. These jumpers must be set according to the type of analog signal that will be connected to the input.

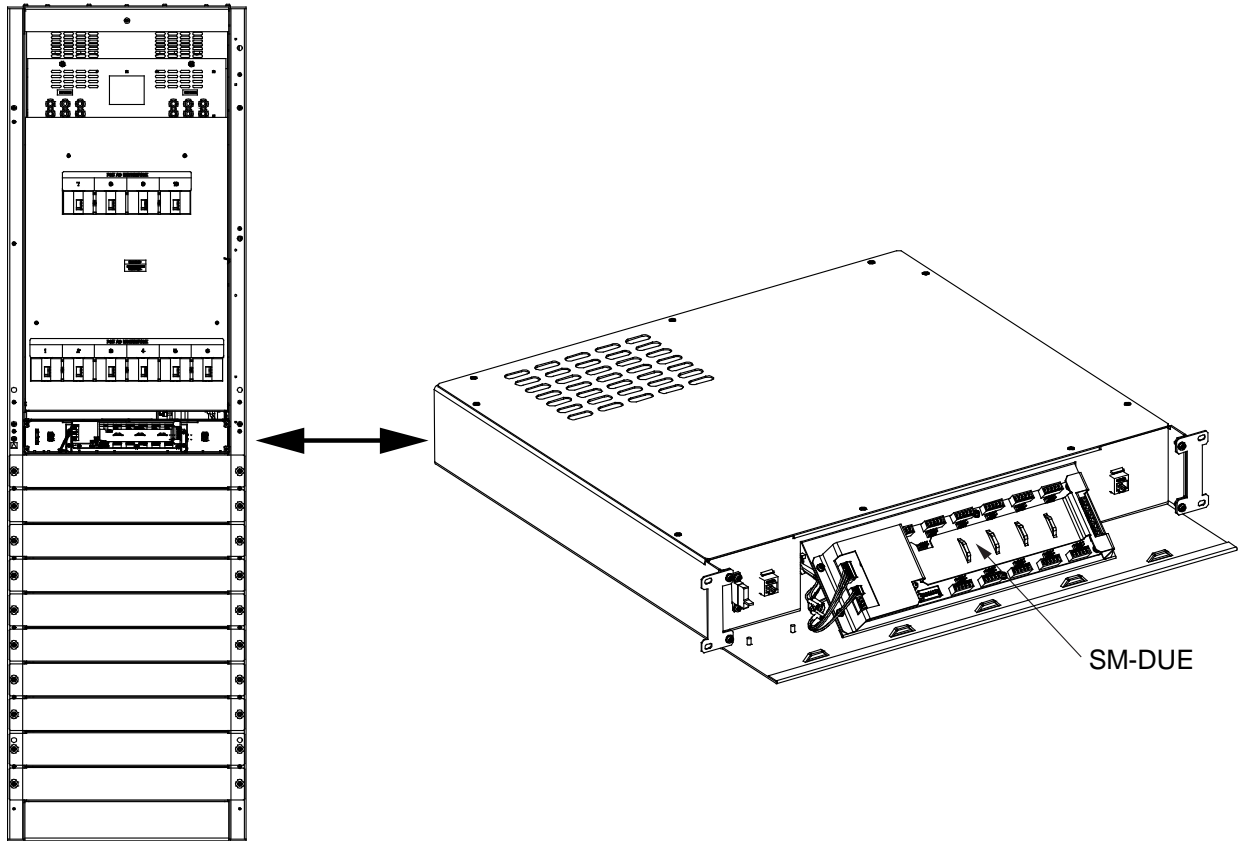
Procedure

1. Set the jumpers on the SM-DUE as required. Refer to **Figure 6.4** for SM-DUE and jumper location. Refer to **Table 6.3** for jumper settings. You can store unused jumpers on one terminal of a jumper connector.

Table 6.3 SM-DUE Jumper Settings

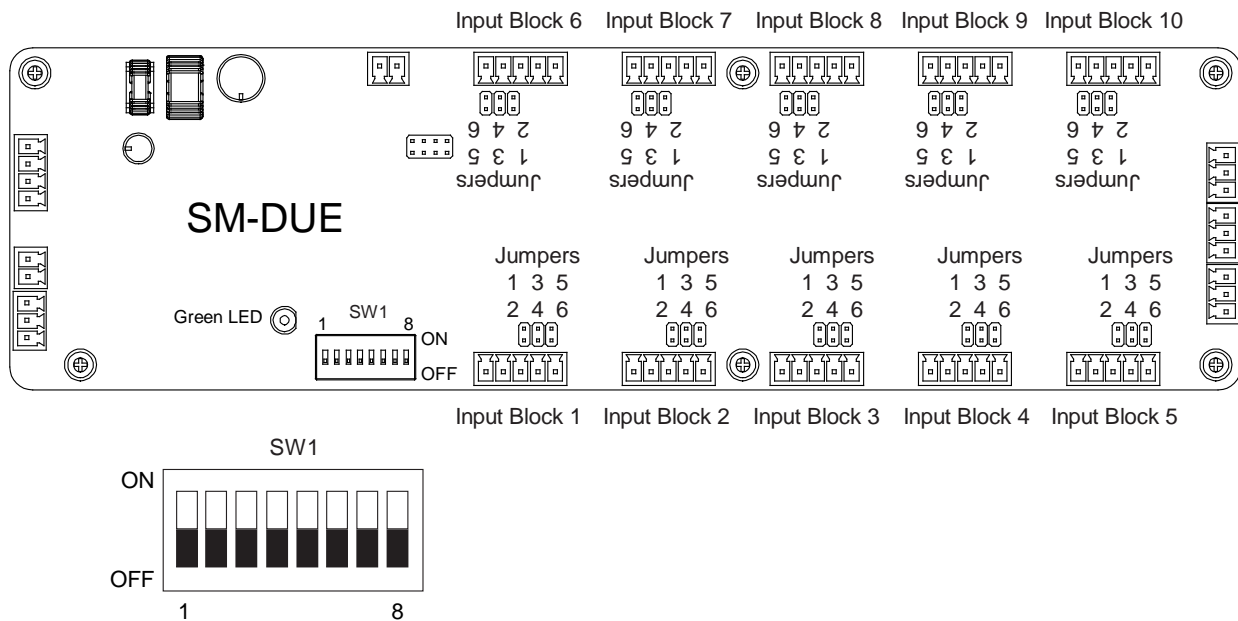
Type of Input Signal (V_AI+ and V_AI- Terminals)	Range	Jumper Position		
		1-2	3-4	5-6
General-Purpose Transducer	0 VDC to 10 VDC	OFF	OFF	OFF
Load Shunt Current	10 mV DC to 50 mV DC	ON	OFF	ON
General-Purpose Transducer	0 mA to 20 mA	ON	ON	OFF
Temperature Sensor	1 μ A/K	ON	OFF	OFF

Figure 6.4 SM-DUE Switch and Jumper Location



Secondary Power Only Bay
 Secondary Power/ Distribution Bay Similar

Front door removed in illustration for clarity only.



6.4 Jumper Setting on Distribution Bus Monitoring Circuit Cards (for use in systems with an MCA only)

The distribution bus monitoring circuit cards (P/N 524982) installed in each power/distribution bay and distribution only bay contain jumper J4. Set this jumper on each circuit card per site requirements. Refer to **Figure 6.5** for distribution bus monitoring circuit card and jumper J4 location. Refer to the following for a description of the jumper.

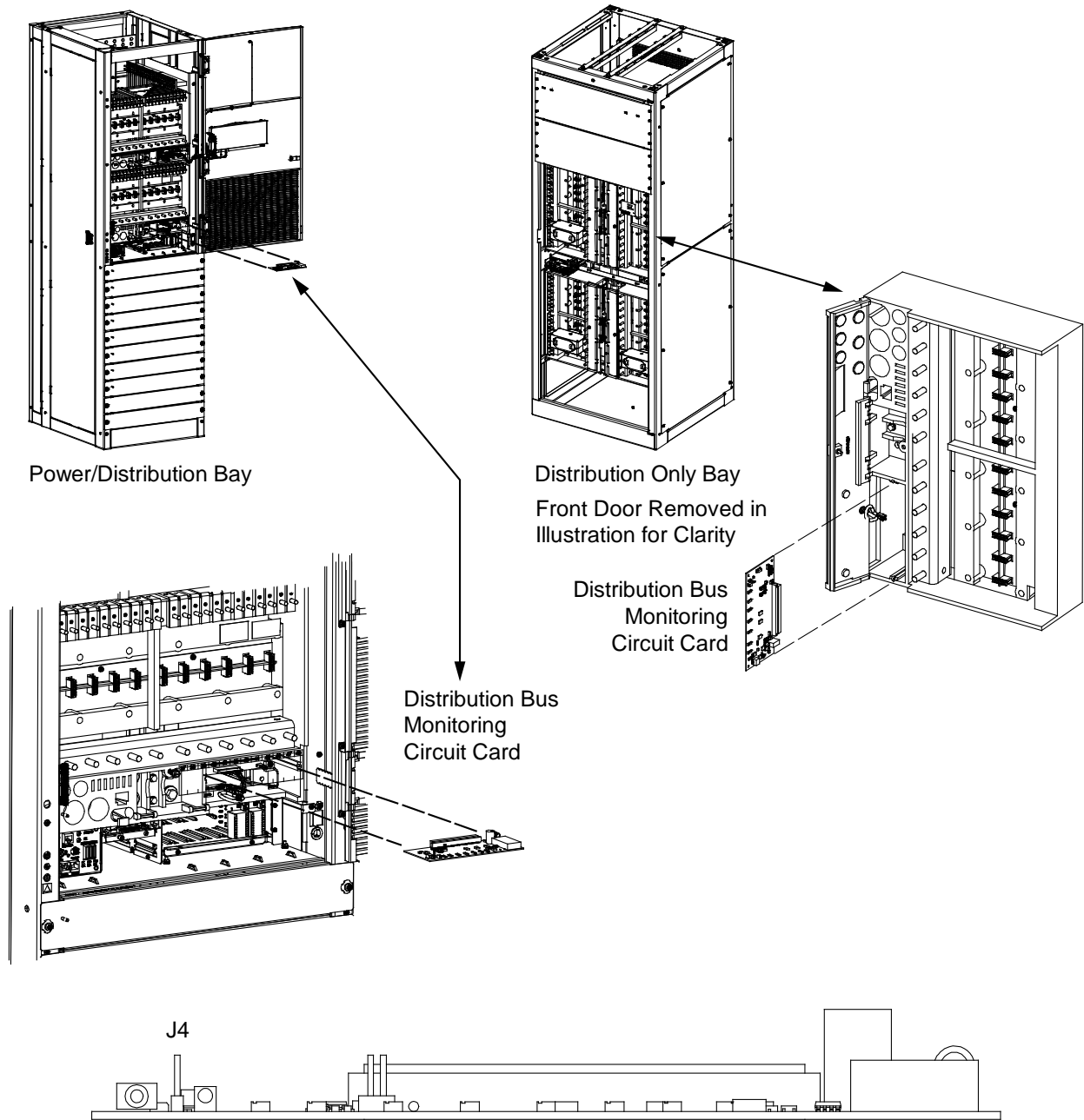


NOTE! *If a jumper is changed on a live system, an alarm is generated. Update inventory to clear the alarm.*

Jumper Description

If the jumper is **installed** between the two pins of J4 on **ALL** distribution bus monitoring circuit cards, then there is **NO A or B distribution designation** in the NCU display of distribution items. If any distribution bus monitoring circuit card has the jumper **removed**, that distribution bus is **designated as B**. Those that have the jumper **remaining (installed)** are **designated as A**.

Figure 6.5 Distribution Bus Monitoring Circuit Card Jumper J4



Distribution Bus Monitoring Circuit Card (P/N 524982)

7 Making Electrical Connections

7.1 Important Safety Instructions



DANGER! Adhere to the “Important Safety Instructions” starting on page vii.

7.2 Wiring Considerations

For recommended wire sizes, crimp lugs, branch circuit protection, alarm relay contact ratings, and general wiring information and restrictions; refer to System Application Guide SAG582140000.

Lugs should be crimped per lug manufacturer’s specifications.

All wiring and branch circuit protection should follow the current edition of the American National Standards Institute (ANSI) approved National Fire Protection Association’s (NFPA) National Electrical Code (NEC), and applicable local codes. For operation in countries where the NEC is not recognized, follow applicable codes. For field wiring, use wires suitable for at least 75°C.

7.3 Bay-to-Bay Interconnections

A bay-to-bay interconnect cable must be installed between all bays comprising the system, as detailed in the following procedure.

It is recommended to place the primary power/distribution bay or primary power only bay on the far right or far left end of the bay line-up, and to expand the system to the left or right of the primary power/distribution bay or primary power only bay. This allows simple cable connections between bays. For this configuration, use the bay-to-bay interconnect cables factory furnished with each secondary power/distribution bay or secondary power only bay.

The primary power/distribution bay or primary power only bay may be placed in the middle of the bay line-up, expanding the system to the left and right of the primary power/distribution bay or primary power only bay. In this configuration, bay-to-bay cabling **MUST** start with the primary power/distribution bay or primary power only bay, then each secondary power/distribution bay or secondary power only bay and distribution only bay is daisy-chained into the cabling string. This configuration requires some of the network cables to be a different length than the standard length cable factory furnished with each secondary power/distribution bay and secondary power only bay and distribution only bay. These cables should have been specified when the system was ordered. Refer to System Application Guide SAG582140000 for available interconnect cable lengths and part numbers.

Procedure



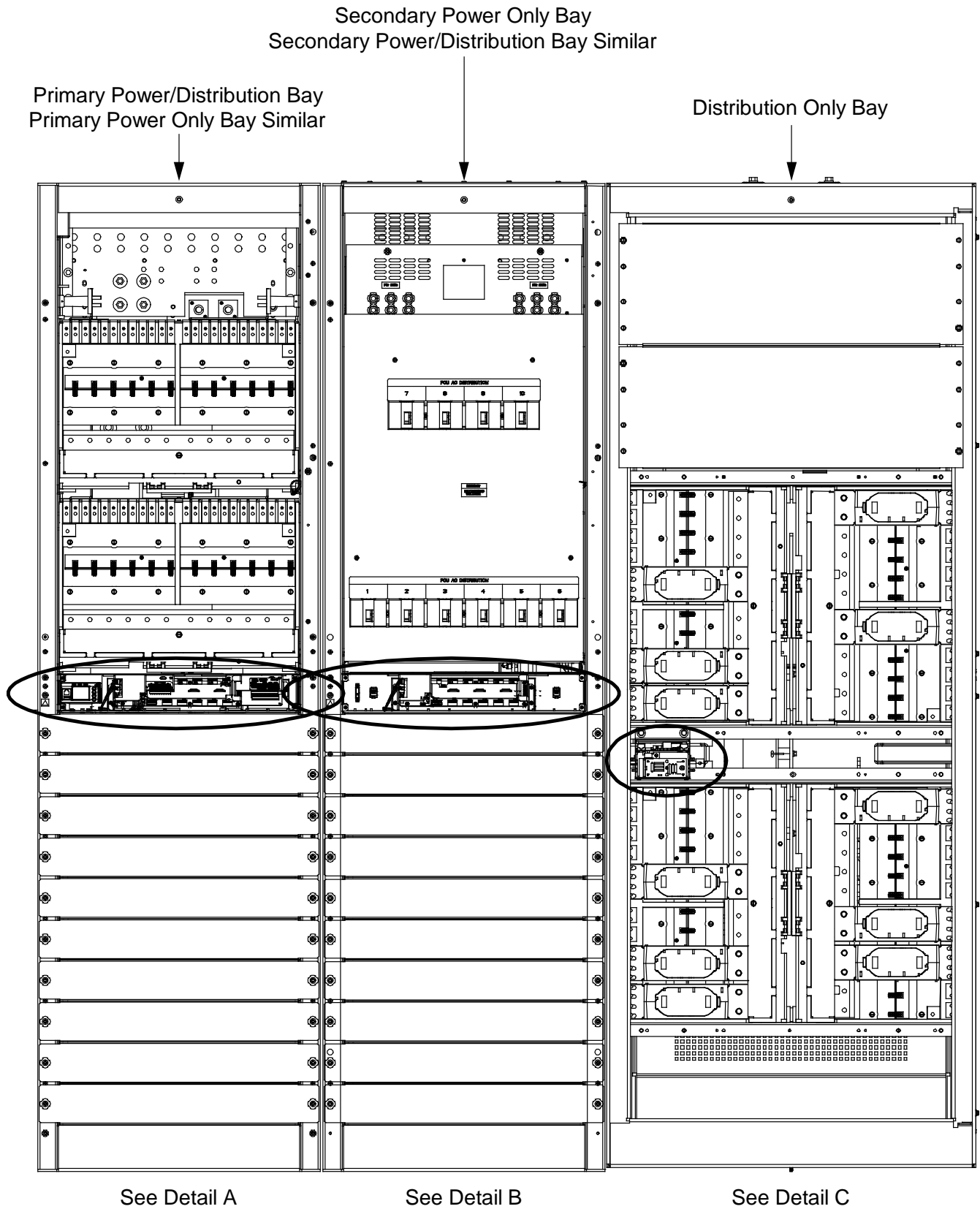
NOTE! Refer to **Figure 7.1** as this procedure is performed.

1. Open all bays' front doors.
2. Connect a furnished interconnect cable (this is a yellow cable) between each bay as follows.
 - a) Connect one end of the cable to the CAN port connector in the primary power/distribution bay or primary power only bay.
 - b) Route the cable through the opening provided in the side of the bay into the next bay. If PDSCs (AC Input 'Power Distribution Service Cabinets') are provided, route the cable through the metal channel provided in the PDSC and into the next bay.
 - c) Connect the other end of the cable to the incoming CAN port connector in the secondary power/distribution bay or secondary power only bay or distribution only bay. If there are additional bays, connect the outgoing CAN port of this bay to the incoming CAN port of the next bay. See **Figure 7.1**. Daisy-chain all secondary power/distribution bays or

secondary power only bays and distribution only bays together in this fashion. The total length of the interconnect cables used cannot exceed 125 feet. Note that if there are bays on both the right and left of the primary power/distribution bay or primary power only bay, once all bays on one side are connected, you have to take a cable from the last bay connected on that side to a bay on the other side of the bay line-up.

3. If no other connections are required within the bays, close all bays' front doors.

Figure 7.1 Bay-Bay Interconnections

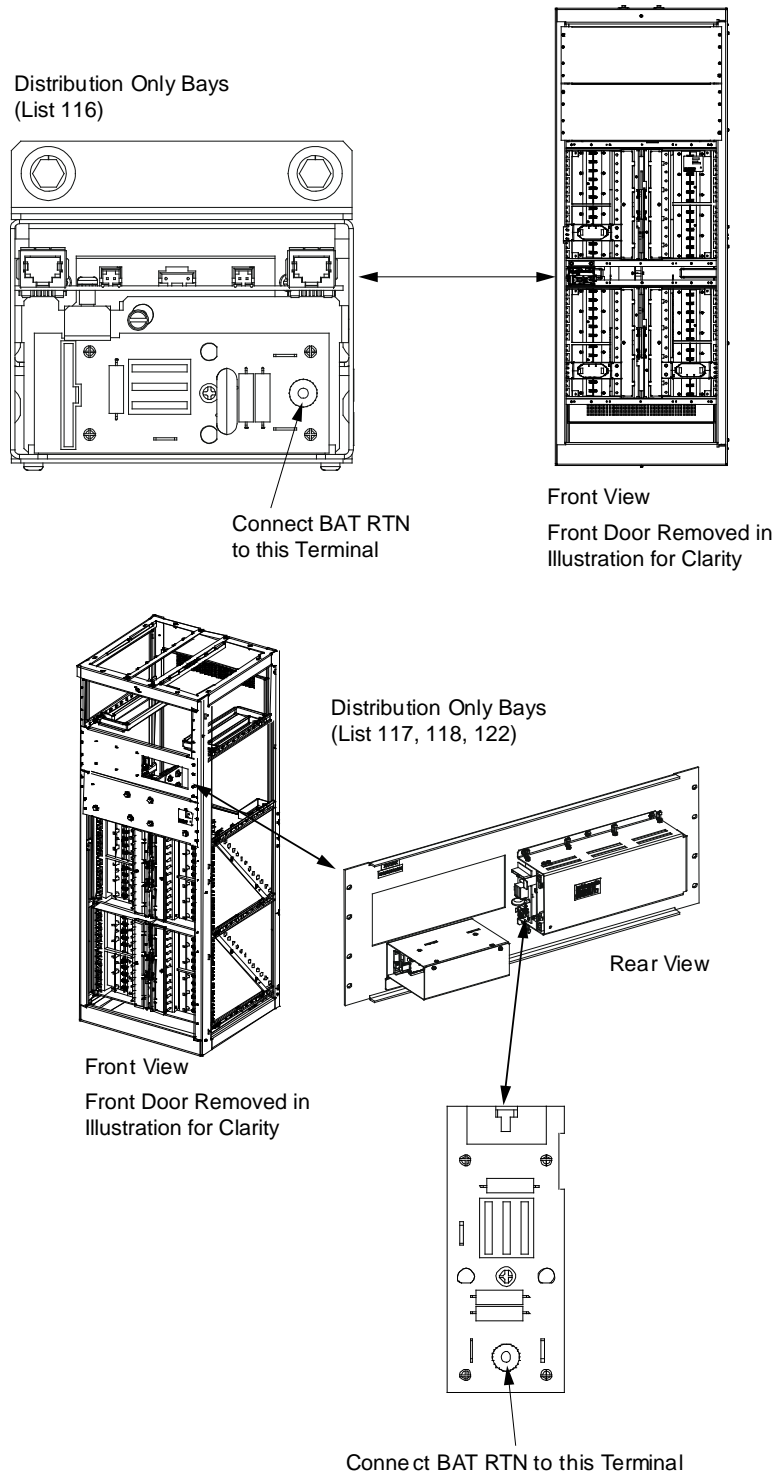


7.4 Distribution Only Bay BAT RTN Connection to System Monitoring and Control Section

Procedure

1. Connect BAT RTN to the terminal indicated in **Figure 7.2**. Use 18-16 AWG wire for this connection.

Figure 7.2 BAT RTN Connection to Distribution Only Bay System Monitoring and Control Section

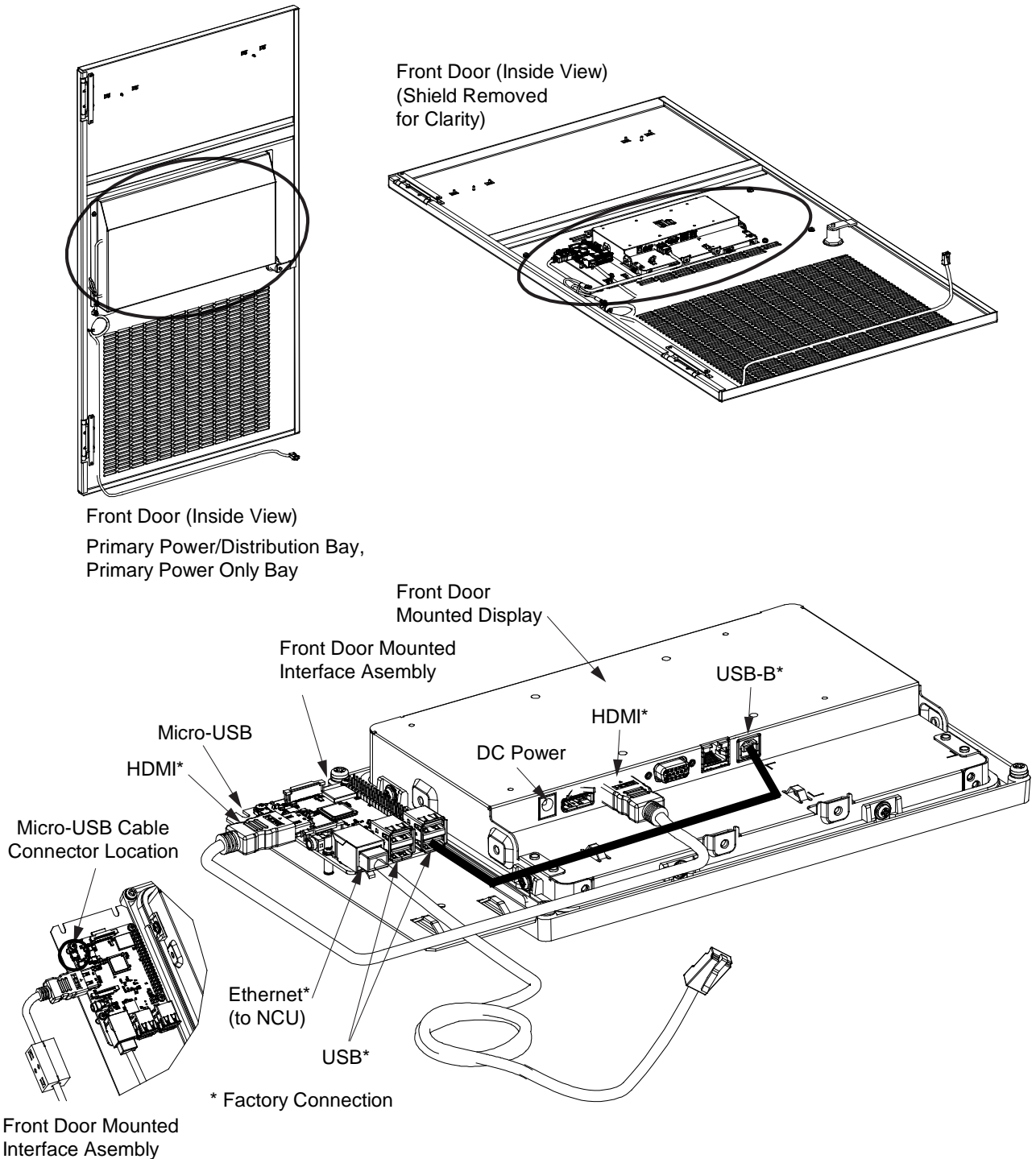


7.5 External Alarm, Reference, and Control Connections

7.5.1 Connector Locations on Inside of Primary Power/Distribution Bay and Primary Power Only Bay Front Door

Refer to **Figure 7.3** for a connector location illustration.

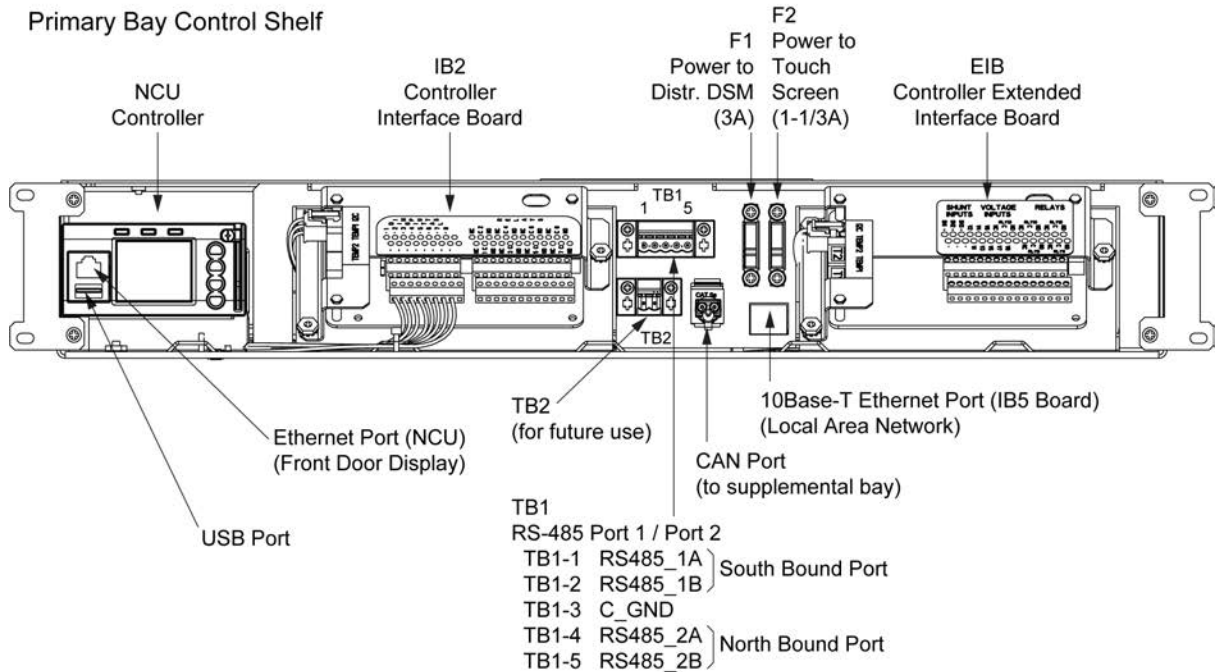
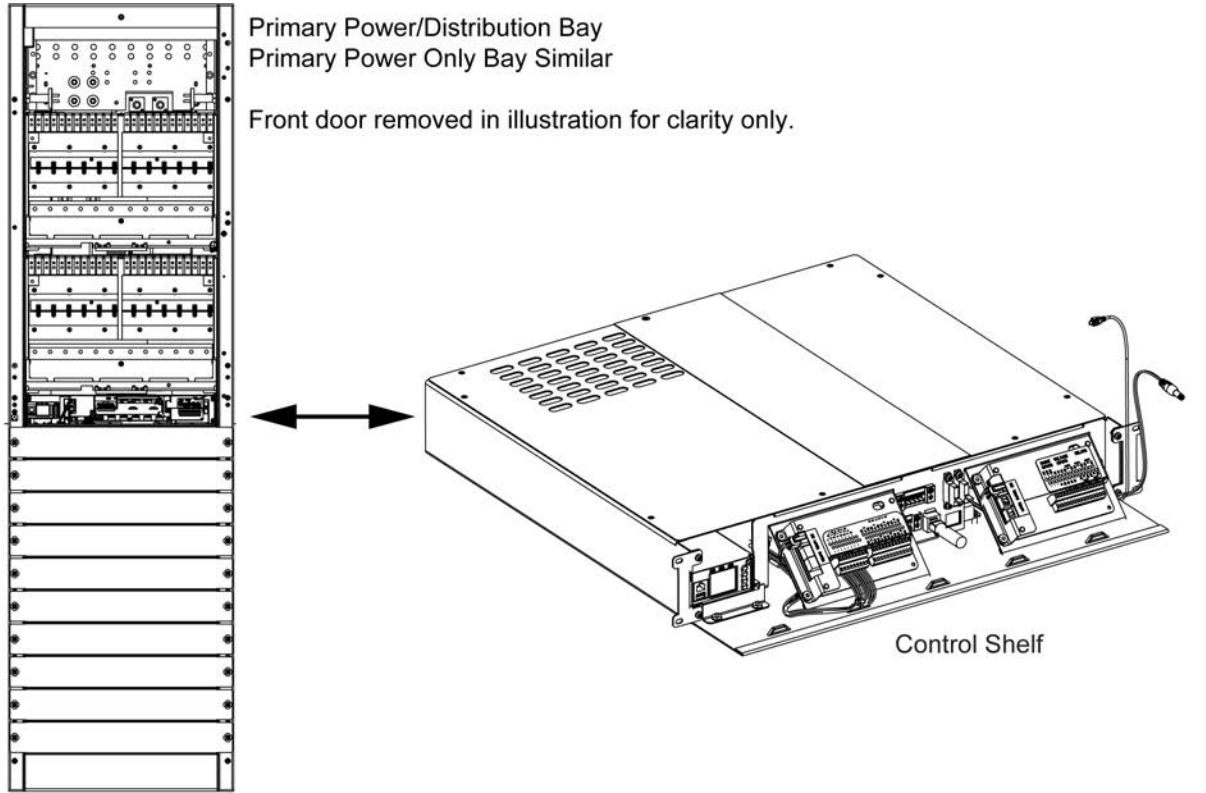
Figure 7.3 Connector Locations – Primary Power/Distribution Bay and Primary Power Only Bay Front Door



7.5.2 Connector Locations on Primary Power/Distribution Bay and Primary Power Only Bay Control Shelf

Refer to **Figure 7.4** for a connector location illustration.

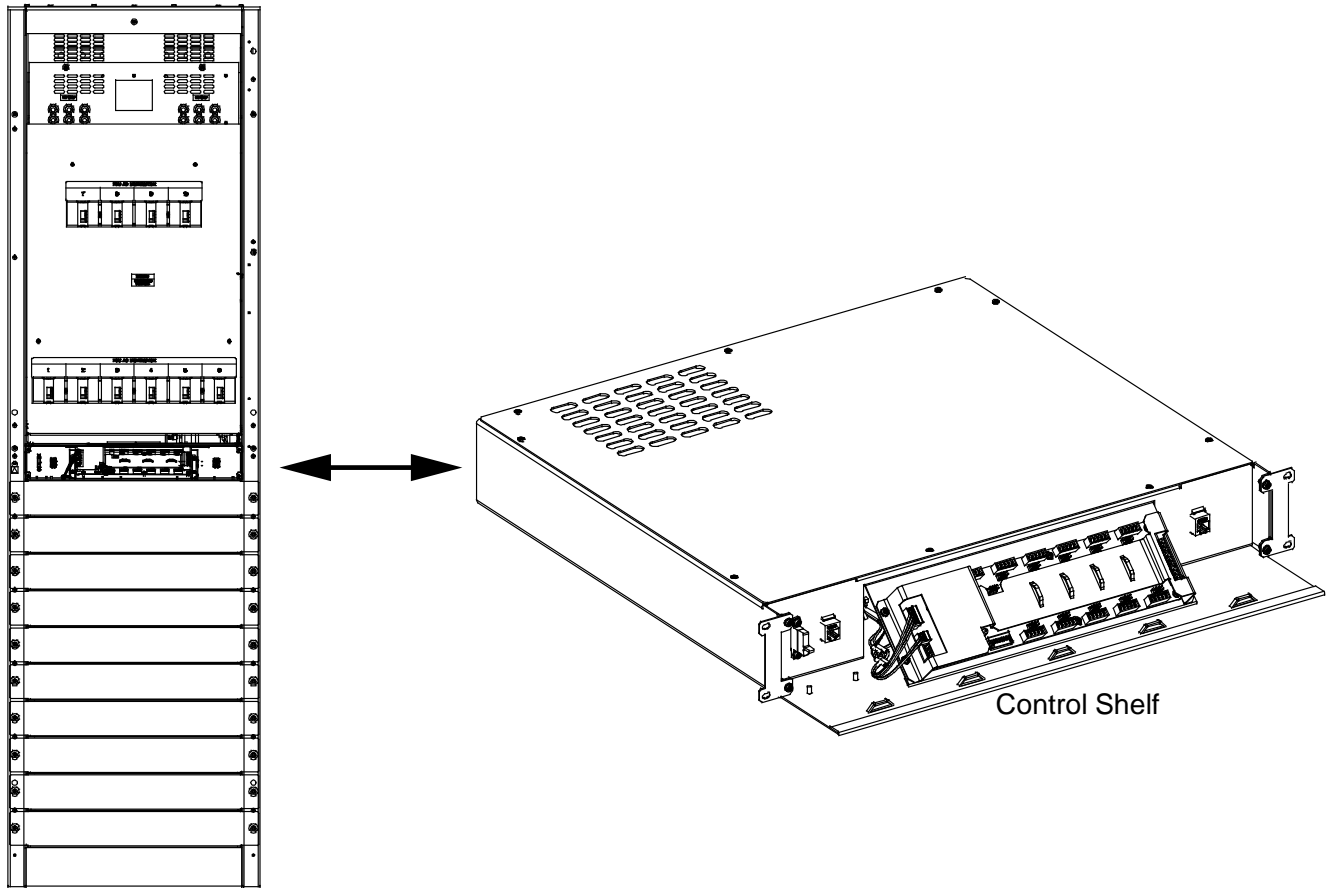
Figure 7.4 Connector Locations – Primary Power/Distribution Bay and Primary Power Only Bay Control Shelf



7.5.3 Connector Locations on Secondary Power/Distribution Bay and Secondary Power Only Bay Control Shelf

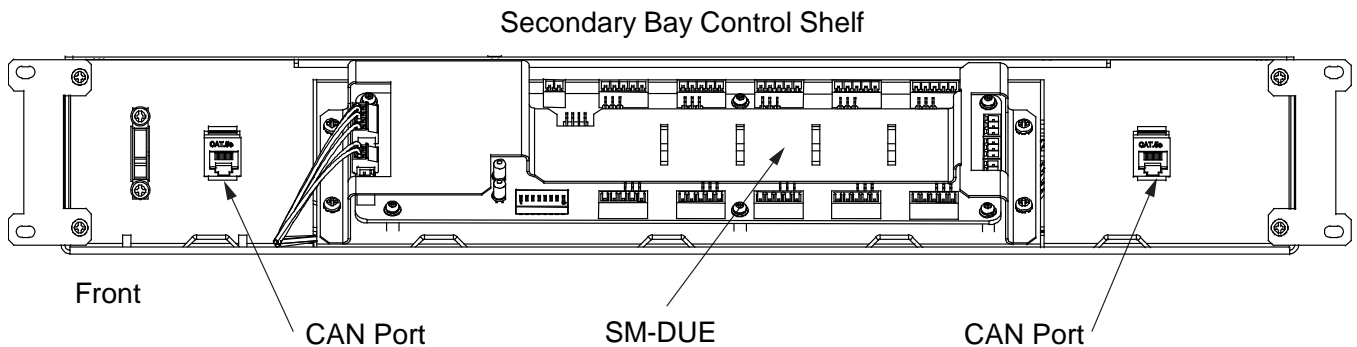
Refer to **Figure 7.5** for a connector location illustration.

Figure 7.5 Connector Locations – Secondary Power/Distribution Bay and Secondary Power Only Bay Control Shelf



Secondary Power Only Bay
 Secondary Power/ Distribution Bay Similar

Front door removed in illustration for clarity only.



7.5.4 Local Area Network (LAN) Ethernet Port Connection (IB5 Board)



NOTE! DO NOT connect your Local Area Network (LAN) to the NCU front panel Ethernet port.



NOTE! IB5 boards with a 10M/100M/1G Ethernet port replaced IB4 boards with a 10M/100M Ethernet port. This transition enables the support of connected devices that communicate up to 1G. While both boards are physically interchangeable, the IB5 board does require the NCU to have V1.2.80 or higher software loaded.

The Local Area Network (LAN) cable is connected to the IB5 board. The IB5 board is mounted inside the primary power/distribution bay or primary power only bay control shelf. Refer to **Figure 7.6** for Ethernet Port connector location.

Default Ethernet Port Parameters (IB5 Board)

IPv4

IP Address: 192.168.1.2
Subnet Mask: 255.255.255.0
Default Gateway: 192.168.1.1

IPv6

IPv6 Address: 20fa:fffd:fffc:fffb:fffa:fff9:fff8:fff7
IPv6 Prefix: 0
IPv6 Gateway: 20fa:1:fffe:ffff:fffd:ffff:fffe

Procedure

1. An RJ-45 10BaseT jack is provided on the IB5 board for connection into a customer's network. This jack has a standard Ethernet pin configuration scheme, twisted pair. Refer to **Figure 7.6** for location and **Table 7.1** for pin outs. Use shielded Ethernet cable (grounded at both ends). Note that the IB5 board's RJ-45 jack is connected to chassis ground. Refer to the NCU controller Instructions (UM1M830BNA) for operational details.



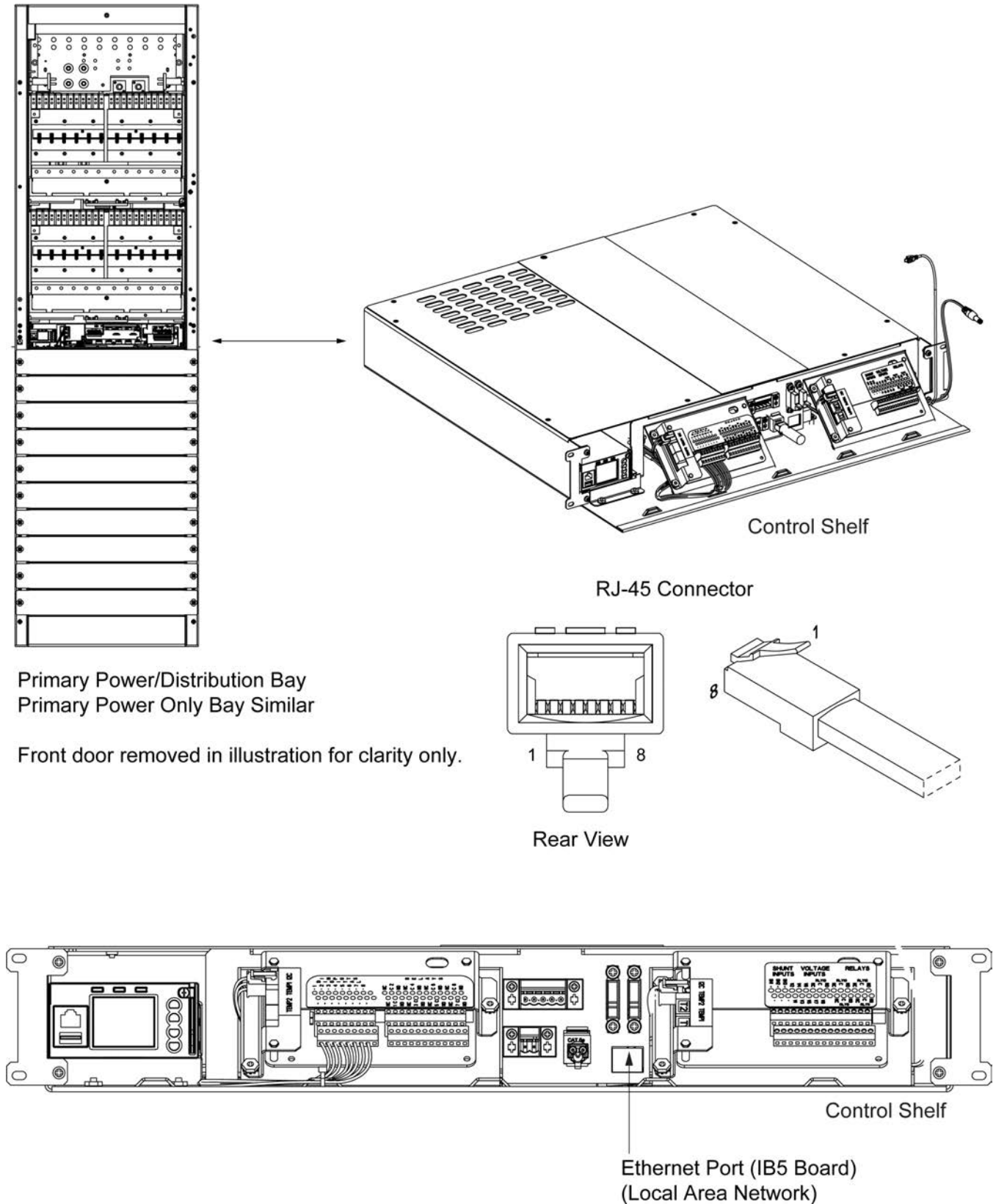
WARNING! The intra-building port(s) of the equipment or subassembly is suitable for connection to intra-building or unexposed wiring or cabling only. The intra-building port(s) of the equipment or subassembly MUST NOT be metallically connected to the interfaces that connect to the OSP or its wiring. These interfaces are designed for use as intra-building interfaces only (Type 2 or Type 4 ports as described in GR-1089-CORE, Issue 4) and require isolation from the exposed OSP cabling. The addition of Primary Protectors is not sufficient protection in order to connect these interfaces metallically to OSP wiring.

The intra-building port (RJ-45) of the equipment or subassembly must use shielded intra-building cabling/wiring that is grounded at both ends.

Table 7.1 RJ-45 Ethernet Port Pin Configuration

Port Pin Number	Name	Definition
1	Tx+	Write Signal +
2	Tx-	Write Signal -
3	Rx+	Read Signal +
4	--	no connection
5	--	no connection
6	Rx-	Read Signal -
7	--	no connection
8	--	no connection

Figure 7.6 Connector Location – Ethernet Port (Local Area Network – LAN)



7.5.5 IB2 (Controller Interface Board) Connections (if required)

The IB2 (Controller Interface Board) provides connection points for digital inputs, programmable relay outputs, and temperature probes. The IB2 board is mounted on the primary power/distribution bay or primary power only bay control shelf. Refer to **Figure 7.4** for IB2 location.

Digital Inputs and Programmable Relay Outputs

Digital input and relay output leads are connected to screw-type terminal blocks located on the IB2 board. Recommended torque for these connections is 2.2 in-lbs. Refer to **Figure 7.7** for terminal locations. Refer to **Table 7.2** and **Table 7.3** for pin-out information.

Digital Inputs

Connect up to eight (8) digital inputs to the IB2 board. Note that you must supply both paths for the digital input (either a positive or negative signal and the opposite polarity return path). Observe proper polarity. Refer to **Figure 7.7** for terminal locations and **Table 7.2** for pin-out information.

The digital inputs can be programmed to provide an alarm when the signal is applied (HIGH) or removed (LOW). Refer to the NCU instructions (UM1M830BNA) for programming information.

Digital Input Ratings: Refer to the following.

- a) Maximum Voltage Rating: 60 VDC.
- b) Active High: > 19 VDC.
- c) Active Low: < 1 VDC.

The digital inputs may be preprogrammed for specific functions. Refer to the configuration drawing (C-drawing) supplied with your system for your system's specific configuration.

Programmable Relay Outputs

The IB2 board provides eight (8) programmable alarm relays with dry Form-C contacts. Connect up to eight (8) relay outputs to the IB2 board. Refer to **Figure 7.7** for terminal locations and **Table 7.3** for pin-out information.

Refer to the NCU instructions (UM1M830BNA) for programming information.

Relay Ratings: Refer to the following.

- a) Steady State: 0.5 A @ 60 VDC; 1 A @ 30 VDC.
- b) Peak: 3 A @ 30 VDC.

The relays may be preprogrammed for specific functions. Refer to the configuration drawing (C-drawing) supplied with your system for your system's specific configuration.

Temperature Probes



NOTE! Each temperature probe consists of two or three pieces that plug together to make a complete probe.

Temperature probes can be connected to the IB2 (Controller Interface Board) and/or EIB (Controller Extended Interface Board) mounted on the control shelf.

Up to two (2) temperature probes can be connected to the IB2 board. Up to two (2) temperature probes can be connected to the EIB board. Any combination of the four (4) temperature probes can be programmed to monitor ambient temperature and/or battery temperature. A temperature probe set to monitor battery temperature can also be used for the rectifier battery charge temperature compensation feature, or the battery charge temperature compensation feature can be programmed to use the average or highest

value of all battery temperature probes. The battery charge temperature compensation feature allows the controller to automatically increase or decrease the output voltage of the system to maintain battery float current as battery temperature decreases or increases, respectively. Battery life can be extended when an optimum charge voltage to the battery with respect to temperature is maintained. A temperature probe set to monitor battery temperature can also be used for the BTRM (Battery Thermal Runaway Management) feature. The BTRM feature lowers output voltage when a high temperature condition exists to control against battery thermal runaway.

The temperature sensor end of the probe contains a tab with a 5/16" clearance hole for mounting.

A temperature probe programmed to monitor battery temperature should be mounted on the negative post of a battery cell to sense battery temperature. A temperature probe used for battery charge temperature compensation and/or BTRM (Battery Thermal Runaway Management) should also be mounted on the negative post of a battery cell. A temperature probe programmed to monitor ambient temperature should be mounted in a convenient location, away from direct sources of heat or cold.

Figure 7.7 IB2 (Controller Interface Board) (cont'd on next page)

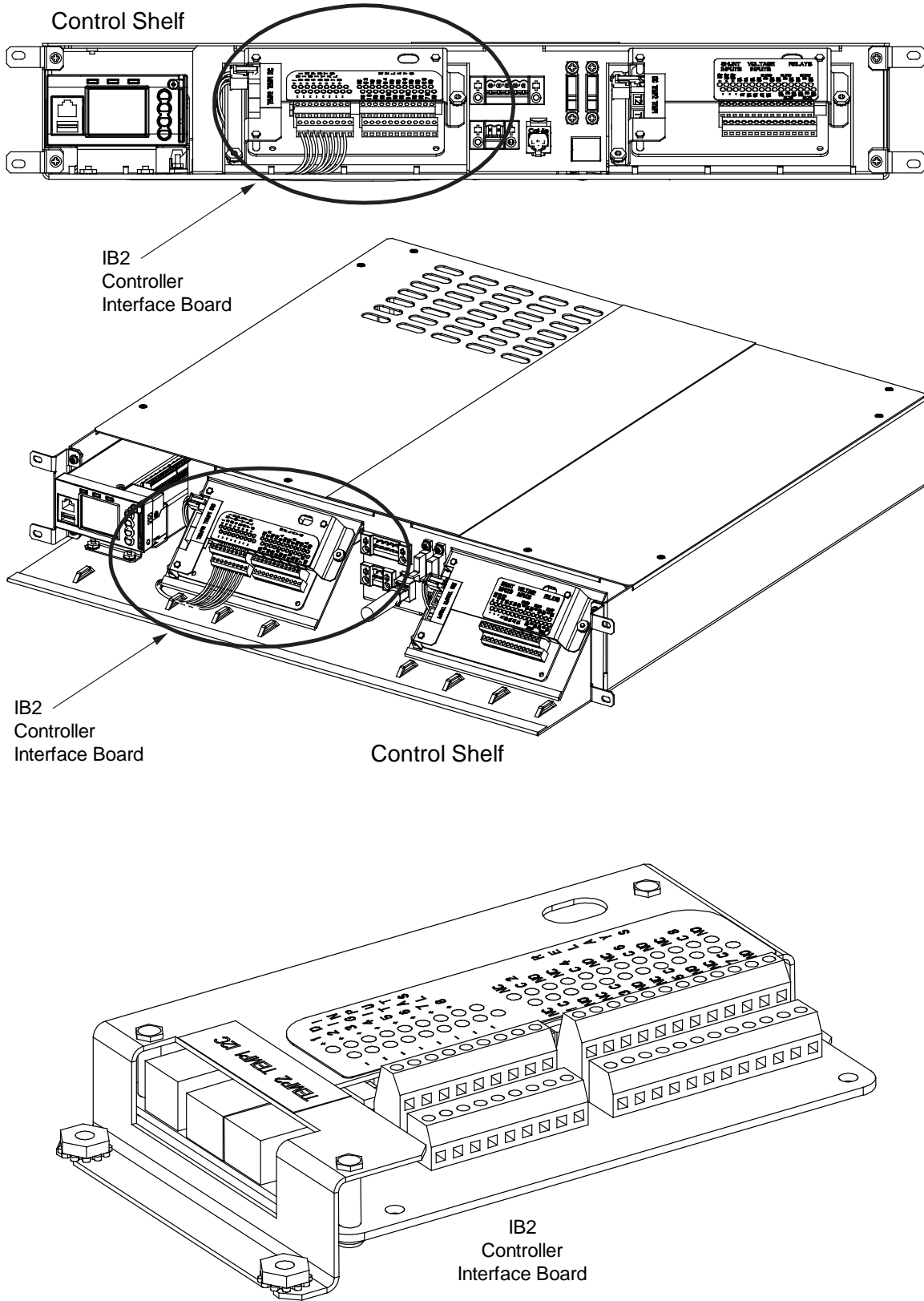
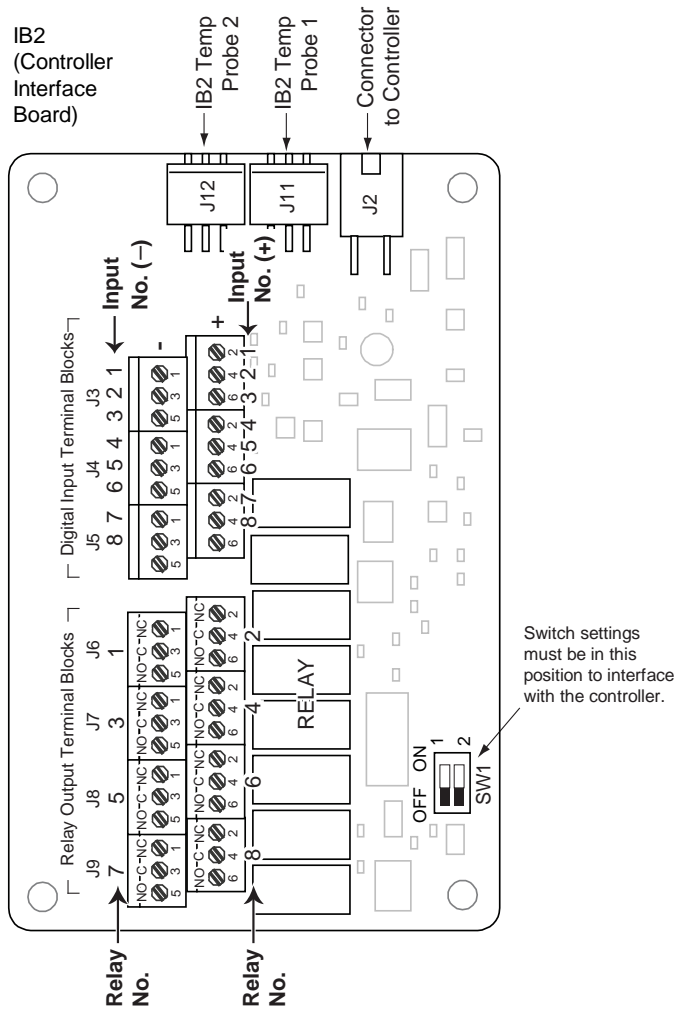
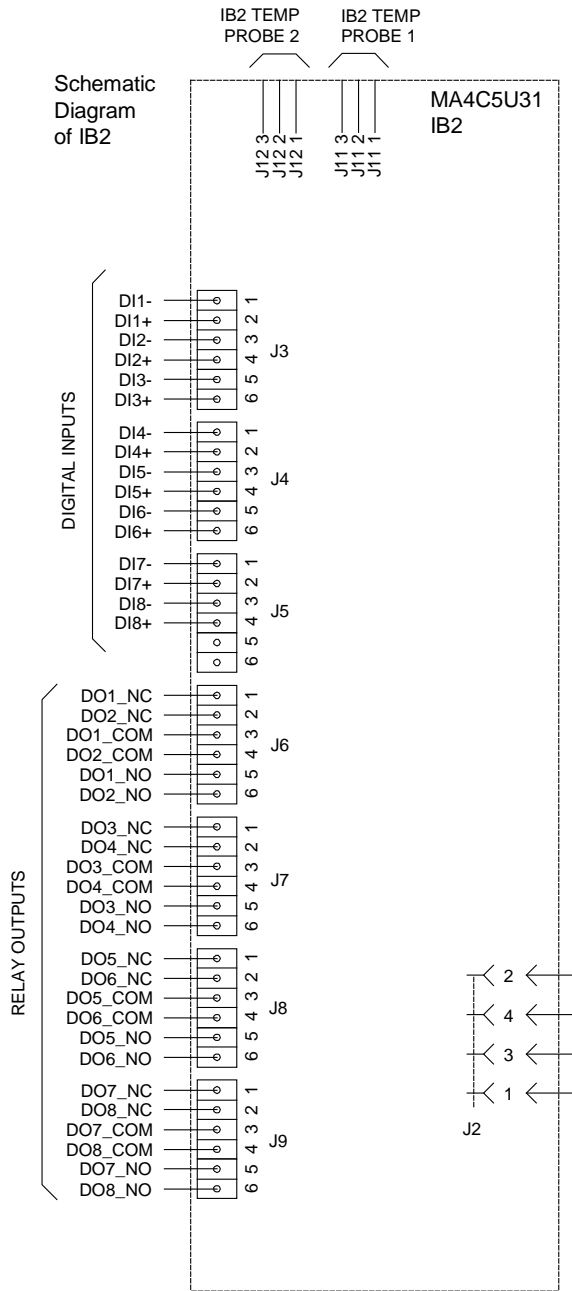
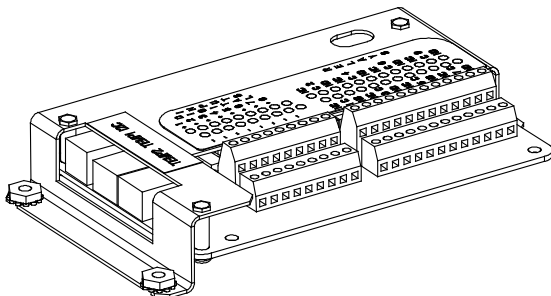


Figure 7.7 IB2 (Controller Interface Board) (cont'd from previous page)



IB2 Assembly



The controller relay assigned to "Major Summary" alarm (relay 1 by default) will operate in the "Fail Safe Mode". "Fail Safe Mode" means Relay 1 is de-energized during an alarm condition, opening the contacts between the C and NO terminals, and closing the contacts between the C and NC terminals.

The controller's remaining seven (7) relays energize during an alarm condition, closing the contacts between the C and NO terminals, and opening the contacts between the C and NC terminals.

Not all I/O points may be available for customer connection (some may be used for factory system connections). Refer to the configuration drawing (C-drawing) supplied with your system for your system's specific configuration.

J3-J9:

- Wire Size Capacity: 16 AWG to 26 AWG.
- Wire Strip Length: 0.20 inch.
- Recommended Torque: 2.2 in-lbs.

Table 7.2 Programmable Digital Inputs (Factory Default) – IB2

Programmable Digital Input	IB2 Pin No.		Factory Wiring	Default Digital Input Function
IB2-1 DI1	J3-1	-	The digital inputs may be preprogrammed for specific functions and have factory wiring connected. Refer to the configuration drawing (C-drawing) supplied with your system for your system's specific configuration.	The digital inputs may be preprogrammed for specific functions. Refer to the configuration drawing (C-drawing) supplied with your system for your system's specific configuration.
	J3-2	+		
IB2-1 DI2	J3-3	-		
	J3-4	+		
IB2-1 DI3	J3-5	-		
	J3-6	+		
IB2-1 DI4	J4-1	-		
	J4-2	+		
IB2-1 DI5	J4-3	-		
	J4-4	+		
IB2-1 DI6	J4-5	-		
	J4-6	+		
IB2-1 DI7	J5-1	-		
	J5-2	+		
IB2-1 DI8	J5-3	-	(to customer ESTOP switch)	ESTOP
	J5-4	+	-48 VDC	
--	J5-5		not used	not used
--	J5-6			



NOTE! -48V is factory wired to the Digital Input #8 (-) terminal for your convenience and function predefined for ESTOP. Customer-furnished system ground applied to terminal Digital Input #8 (+) activates the ESTOP function. The ESTOP function shuts down and locks out the rectifiers. To restart the rectifiers, remove the ESTOP signal and turn AC power to the rectifiers OFF, wait 30 seconds or more (until the LEDs on the rectifier extinguish), then turn AC power to the rectifiers ON.

If a customer-furnished method to disconnect the input power to the system is not provided, the rectifiers will stay locked OFF until the input power is recycled. If the ESTOP signal is removed without recycling the input power, the rectifiers will remain off. The ESTOP alarm from the controller will extinguish. The controller will not issue an alarm for this condition.



NOTE! The digital inputs may be preprogrammed for specific functions. Refer to the configuration drawing (C-drawing) supplied with your system for your system's specific configuration.

Table 7.3 Relay Outputs (Factory Default) – IB2

Programmable Relay Output		IB2 Pin No.	Alarms Assigned to this Relay (Default)
IB2-1 DO1	NC	J6-1	Major Summary
	COM	J6-3	
	NO	J6-5	
IB2-1 DO2	NC	J6-2	Minor Summary
	COM	J6-4	
	NO	J6-6	
IB2-1 DO3	NC	J7-1	Mains Failure
	COM	J7-3	
	NO	J7-5	
IB2-1 DO4	NC	J7-2	Fuse Alarm
	COM	J7-4	
	NO	J7-6	
IB2-1 DO5	NC	J8-1	Under Voltage 1
	COM	J8-3	
	NO	J8-5	
IB2-1 DO6	NC	J8-2	Over Voltage 1
	COM	J8-4	
	NO	J8-6	
IB2-1 DO7	NC	J9-1	Under Voltage 2
	COM	J9-3	
	NO	J9-5	
IB2-1 DO8	NC	J9-2	Over Voltage 2
	COM	J9-4	
	NO	J9-6	



NOTE! The controller relay assigned to “Major Summary” alarm (relay 1 by default) will operate in the “Fail Safe Mode”. “Fail Safe Mode” means Relay 1 is de-energized during an alarm condition, opening the contacts between the C and NO terminals, and closing the contacts between the C and NC terminals. The controller’s seven (7) remaining relays energize during an alarm condition, closing the contacts between the C and NO terminals, and opening the contacts between the C and NC terminals.



NOTE! The relays may be preprogrammed for specific functions. Refer to the configuration drawing (C-drawing) supplied with your system for your system’s specific configuration.

7.5.6 EIB (Controller Extended Interface Board) Connections (if required)

The EIB (Controller Extended Interface Board) provides additional connection points for voltage and current inputs, programmable relay outputs, and temperature probes. The EIB board is mounted on the primary power/distribution bay or primary power only bay control shelf. Refer to **Figure 7.4** for EIB location.

Current Inputs, Voltage Inputs, and Programmable Relay Outputs

Current input, voltage input, and relay output leads are connected to screw-type terminal blocks located on the EIB board. Recommended torque for these connections is 2.2 in-lbs. Refer to **Figure 7.8** for terminal locations. Refer to **Table 7.4**, **Table 7.5**, and **Table 7.6** for pin-out information.

Current Inputs

Connect up to three (3) shunt inputs to the EIB board. Observe proper polarity. Refer to **Figure 7.8** for terminal locations and **Table 7.4** for pin-out information.

Refer to the NCU instructions (UM1M830BNA) and program the shunt input parameters found in the EIB menu.



NOTE! The shunt needs to be installed in the hot (-48V) bus. Connect the plus side of the shunt to the positive shunt input on the EIB board. Connect the negative side of the shunt to the negative shunt input on the EIB board.

Voltage Inputs for Battery Block and Battery Midpoint Monitoring

The NCU can monitor battery blocks (12V blocks) or midpoint battery voltage of battery strings connected to the EIB board. The EIB board provides a total of eight (8) DC voltage inputs for these connections. An alarm is issued when either battery block voltage or battery midpoint voltage is abnormal. Refer to **Figure 7.8** for terminal locations and **Table 7.5** for pin-out information.

Refer to **Figure 7.9** for connection details. Refer to the NCU instructions (UM1M830BNA) and program the following parameters found in the EIB menu.



NOTE! When using Battery Block Monitoring, you must make connections to all blocks.

Midpoint Monitoring

Voltage Type: Set to "Midpoint". This selects the EIB board to monitor the midpoint voltage of up to eight (8) battery strings.

BlockVDiff (Mid): This menu item appears if "Midpoint" is selected above. Set to the alarm threshold for battery midpoint monitoring per site requirements. The NCU issues an alarm when any battery midpoint voltage of any battery string has an abnormal value. The alarm is issued when the difference between any battery midpoint voltage and a reference voltage is greater than the value of the block voltage difference setting.

Block In-Use: Set to number of 12V battery blocks being used.

Battery Block Monitoring

Voltage Type: Set to "48 (Block 4)". This selects the EIB board to monitor up to two (2) 48V battery strings with four (4) 12V blocks per string.

BlockVDiff (12V): This menu item appears if "48 (Block 4)" is selected above. Set to the alarm threshold for battery block monitoring per site requirements. The NCU issues an alarm when any block voltage of any battery string has an abnormal value. The alarm is issued when the difference between any block voltage and a reference voltage is greater than the value of the block voltage difference setting.

Block In-Use: Set to the number of 12V battery blocks being used.

Programmable Relay Outputs

The EIB board provides five (5) programmable alarm relays with dry Form-C contacts. Connect up to five (5) relay outputs to the EIB board. Refer to **Figure 7.8** for terminal locations and **Table 7.6** for pin-out information.

Refer to the NCU instructions (UM1M830BNA) for programming information.

Relay Ratings: Refer to the following.

- a) Steady State: 0.5 A @ 60 VDC; 1 A @ 30 VDC.
- b) Peak: 3 A @ 30 VDC.

The relays may be preprogrammed for specific functions. Refer to the configuration drawing (C-drawing) supplied with your system for your system's specific configuration.

Temperature Probes

Temperature probes can be connected to the EIB board. Refer to "Temperature Probes" on page 118.

Figure 7.8 EIB (Controller Extended Interface Board) (cont'd on next page)

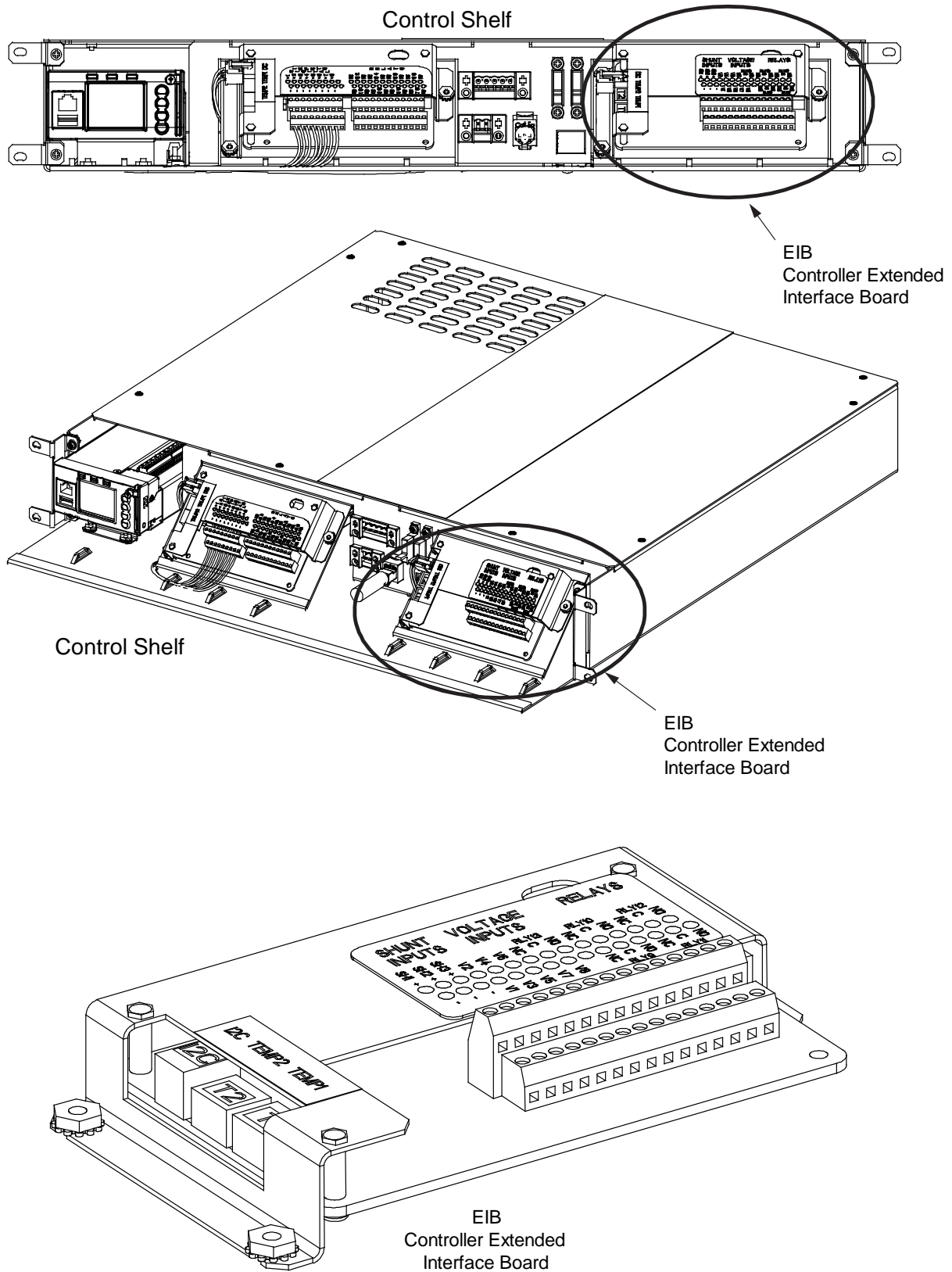
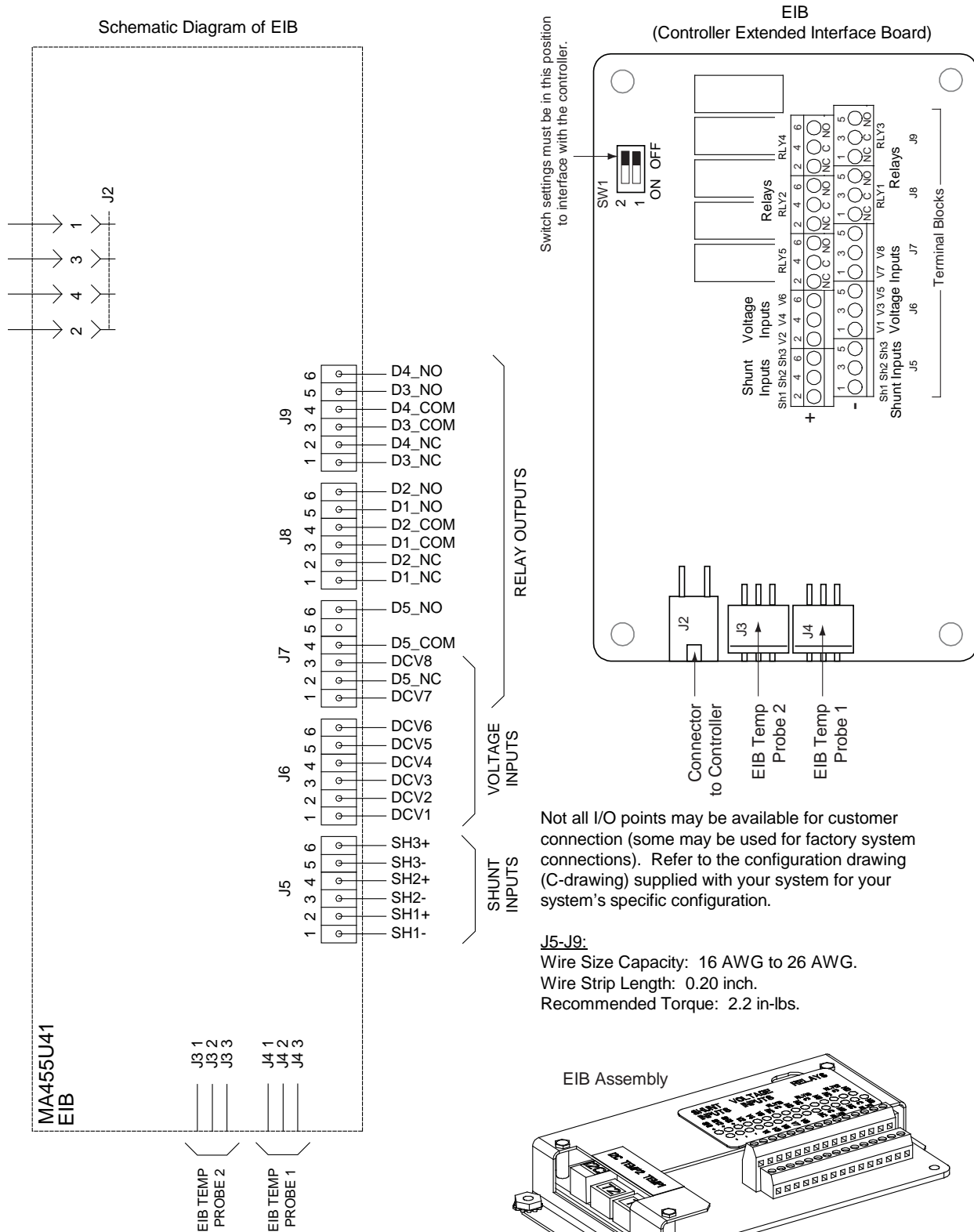


Figure 7.8 EIB (Controller Extended Interface Board) (cont'd from previous page)



Not all I/O points may be available for customer connection (some may be used for factory system connections). Refer to the configuration drawing (C-drawing) supplied with your system for your system's specific configuration.

J5-J9:
 Wire Size Capacity: 16 AWG to 26 AWG.
 Wire Strip Length: 0.20 in.
 Recommended Torque: 2.2 in-lbs.

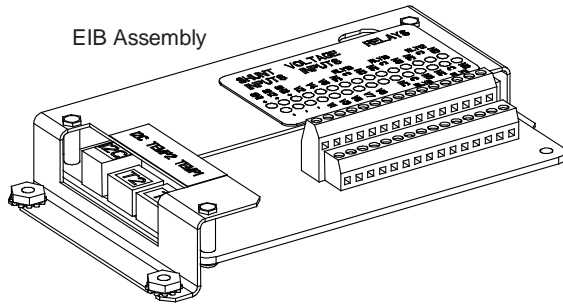


Table 7.4 Shunt Inputs – EIB

Shunt Input	EIB Pin No.		Factory Wiring	Default Function
Sh1	J5-1	-	--	none
	J5-2	+	--	
Sh2	J5-3	-	--	none
	J5-4	+	--	
Sh3	J5-5	-	--	none
	J5-6	+	--	

Table 7.5 Voltage Inputs – EIB

Voltage Input	EIB Pin No.	Default Function
1	J6-1	Battery Block Monitoring
2	J6-2	
3	J6-3	
4	J6-4	
5	J6-5	
6	J6-6	
7	J7-1	
8	J7-3	

Table 7.6 Relay Outputs (Factory Default) – EIB

Programmable Relay Output		EIB Pin No.	Alarms Assigned to this Relay (Default)
EIB-1 DO1	NC	J8-1	Not Used
	COM	J8-3	
	NO	J8-5	
EIB-1 DO2	NC	J8-2	Test / Equalize
	COM	J8-4	
	NO	J8-6	
EIB-1 DO3	NC	J9-1	Rectifier Alarms
	COM	J9-3	
	NO	J9-5	
EIB-1 DO4	NC	J9-2	Multi-Rectifier Fail
	COM	J9-4	
	NO	J9-6	
EIB-1 DO5	NC	J7-2	OB Summary
	COM	J7-4	
	NO	J7-6	

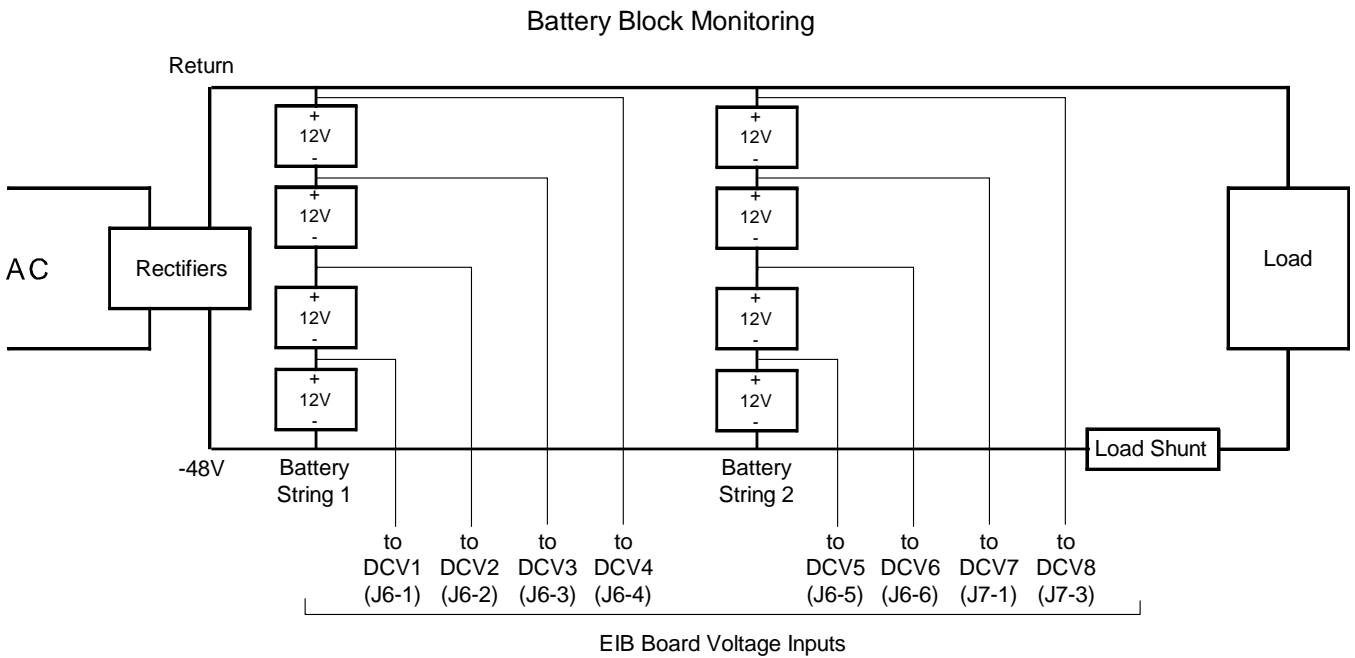
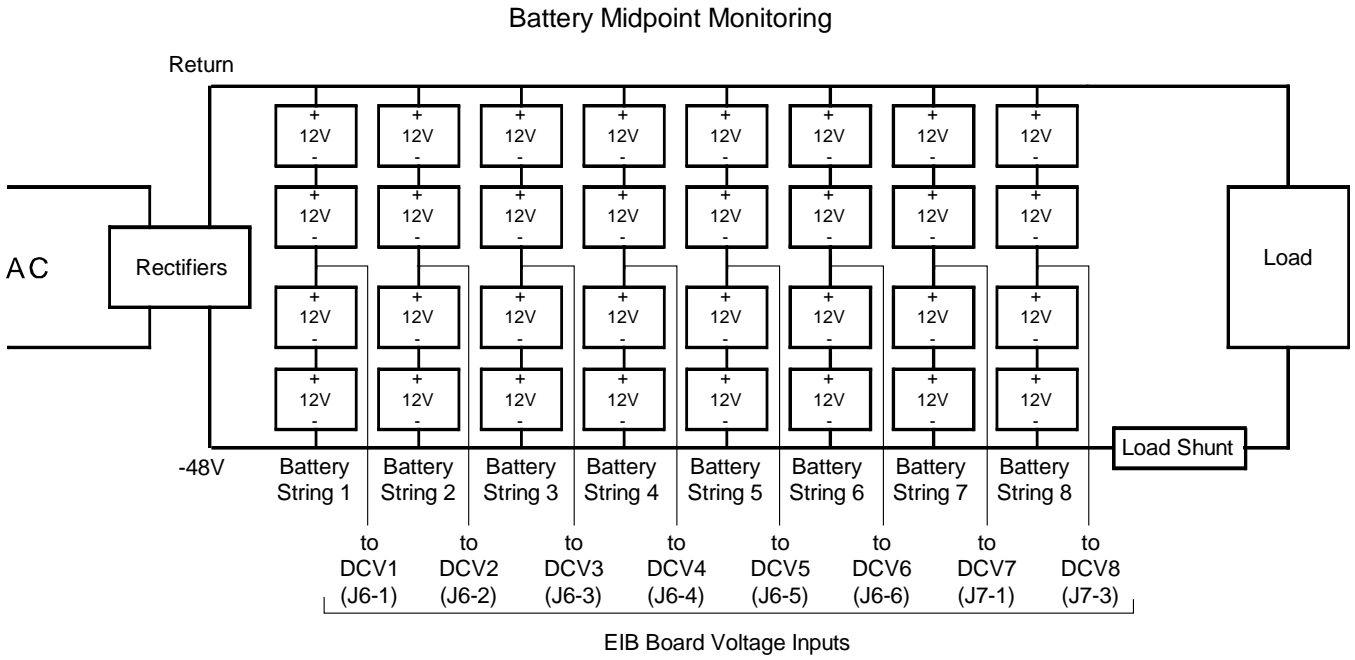


NOTE! The relays energize during an alarm condition, closing the contacts between the C and NO terminals, and opening the contacts between the C and NC terminals.



NOTE! The relays may be preprogrammed for specific functions. Refer to the configuration drawing (C-drawing) supplied with your system for your system's specific configuration.

Figure 7.9 Sample Battery Midpoint Monitoring or Battery Block Monitoring Connections



7.5.7 Customer Connections to SM-DUE (if required)

General

Each secondary power/distribution bay and secondary power only bay contains a secondary control shelf. The secondary control shelf contains an SM-DUE. The SM-DUE is used to input external monitoring information to the NCU controller. Customer connections are provided for the following:

- SM-DUE Input Power Voltage (19 VDC to 60 VDC)
- +5 VDC Power Supply Output for Connection to External Hall Devices
- Ten (10) input blocks with each providing the following monitoring inputs:
 - One (1) Load Bus Voltage (0 VDC to 60 VDC) per input block
 - One (1) Load Fuse Alarm (Bus- base of 0 VDC, >10 VDC alarm, <10 VDC normal) per input block
 - One (1) Programmable Analog Input, can be set to accept one (1) of the following inputs per input block:
 - 10 mV DC to 50 mV DC Load Shunt
 - General-Purpose Current Transducer
 - General-Purpose Voltage Transducer
 - 1 uA/K Temperature Sensor

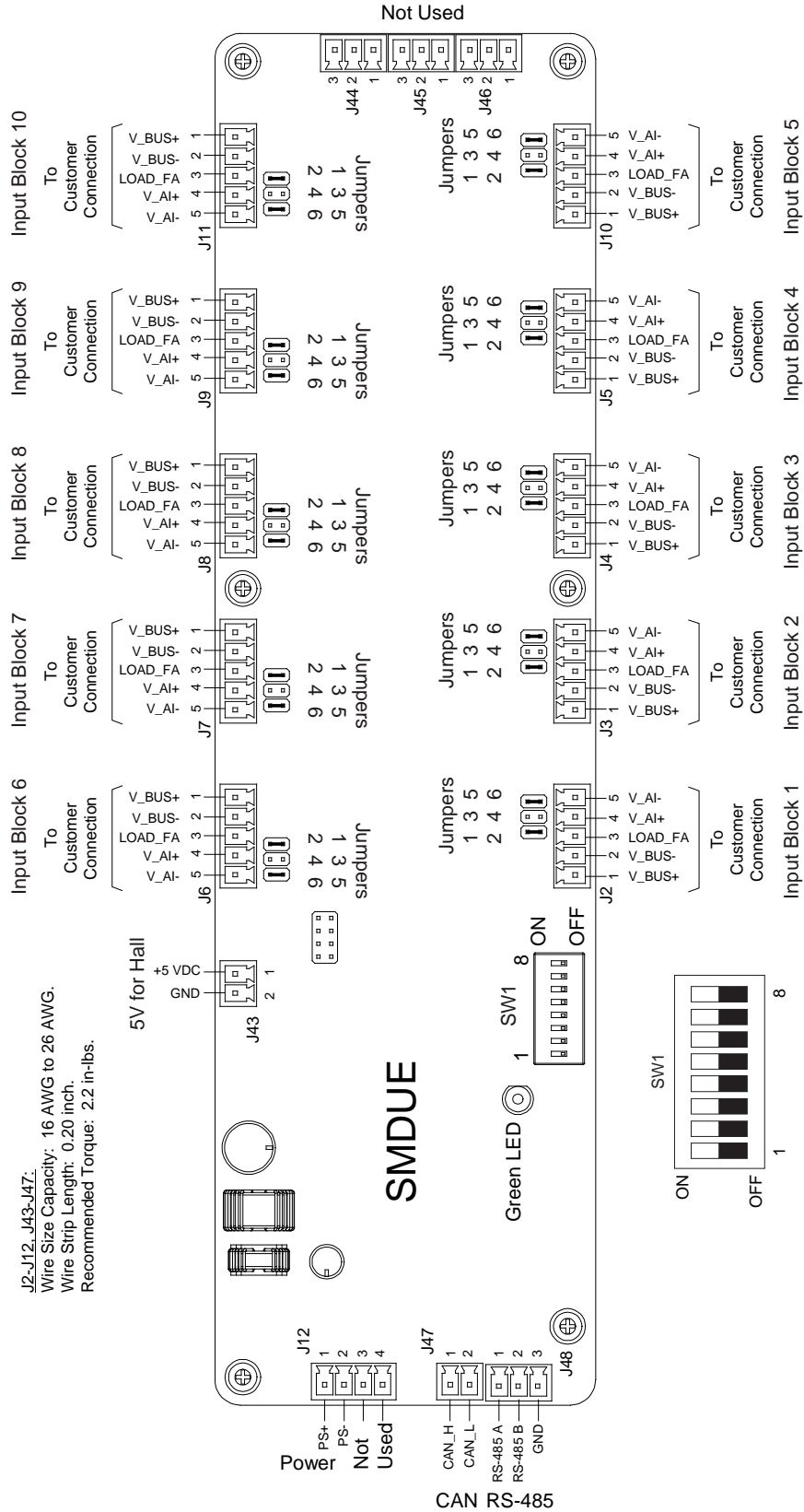


NOTE! Only the SM DUE designated as SMDUE1 and SMDUE2 via the addressing switches can have temperature probes connected to them.

- CAN Bus Port

Refer to the following procedures and make connections to the SM-DUE as required. Refer to **Figure 7.5** for SM-DUE location. Refer to **Figure 7.10** for SM-DUE connector locations. See also “Switch Settings on SM-DUE” on page 103 and “Jumper Settings on SM-DUE” on page 104.

Figure 7.10 SM-DUE Connector Locations



Input Power Voltage Connection

General

- Input power to the SM-DUE is connected to J12.
- Refer to **Table 7.7** for connector pinout information.
- Refer to **Figure 7.10** for connector location.

Table 7.7 Input Power Voltage Connector J12

Connector	Pin No.	Signal Name	Signal Symbol	Description
J12	1	Power Input+	PS+	Positive (+) Input Power Lead
	2	Power Input-	PS-	Negative (-) Input Power Lead
	3	Not Used		
	4	Not Used		

Procedure



WARNING! Check for correct polarity before making connections.

1. Connections to pin 1 and 2 of J12 are factory made.

+5 VDC Power Supply Output Connection

General

- The SM-DUE contains a +5 VDC power supply. Input power to a Hall device can be connected to J43.
- Refer to **Table 7.8** for connector pinout information.
- Refer to **Figure 7.10** for connector location.

Table 7.8 Input Power to Hall Device Connector J43

Connector	Pin No.	Signal Name	Signal Symbol	Description
J43	1	Power Supply Output+	+5 VDC	Power Output for Hall Sensor Device
	2	Power Supply Output-	GND	

Procedure

1. Connect the positive (+) input power lead from a Hall device to pin 1 of J43.
2. Connect the negative (-) (ground) input power lead from a Hall device to pin 2 of J43.


Ten (10) Monitoring Input Blocks Connections

General

- Inputs to the ten (10) monitoring input blocks are connected to J2, J3, J4, J5, J6, J7, J8, J9, J10, and J11.
- Refer to **Table 7.9** for connector pinout information. Refer to **Table 7.10** for input block and connector mapping.
- Refer to **Figure 7.10** for connector location.
- See also “Switch Settings on SM-DUE” on page 103 and “Jumper Settings on SM-DUE” on page 104.

Table 7.9 Input Block Monitoring Input Signals Connectors J2, J3, J4, J5, J6, J7, J8, J9, J10, J11

Connector	Pin No.	Signal Name	Signal Symbol	Description
J2, J3, J4, J5, J6, J7, J8, J9, J10, J11	1	Positive (+) Load Bus Voltage	V_BUS+	Load Bus Voltage Monitoring
	2	Negative (-) Load Bus Voltage	V_BUS-	
	3	Load Fuse Alarm	LOAD_FA	Load Fuse Alarm Monitoring
	4	Positive (+) Analog Input	V_AI+	See Note Below
	5	Negative (-) Analog Input	V_AI-	

 **NOTE!** Terminals 4 and 5 of J2, J3, J4, J5, J6, J7, J8, J9, J10, J11 can be set to accept one (1) of four (4) types of input signals via jumper settings: 0 VDC to 10 VDC general-purpose transducer, 0 mV DC to 50 mV DC load shunt (only load shunts are supported at this time), 0 mA to 20 mA general-purpose transducer, and 1 uA/K temperature sensor. See also “Jumper Settings on SM-DUE” on page 104.


 **NOTE!** Only the SM DUE designated as SMDUE1 and SMDUE2 via the addressing switches can have temperature probes connected to them.

Table 7.10 Input Block and Connector Mapping

Input Block	1	2	3	4	5	6	7	8	9	10
Connector	J2	J3	J4	J5	J10	J6	J7	J8	J9	J11

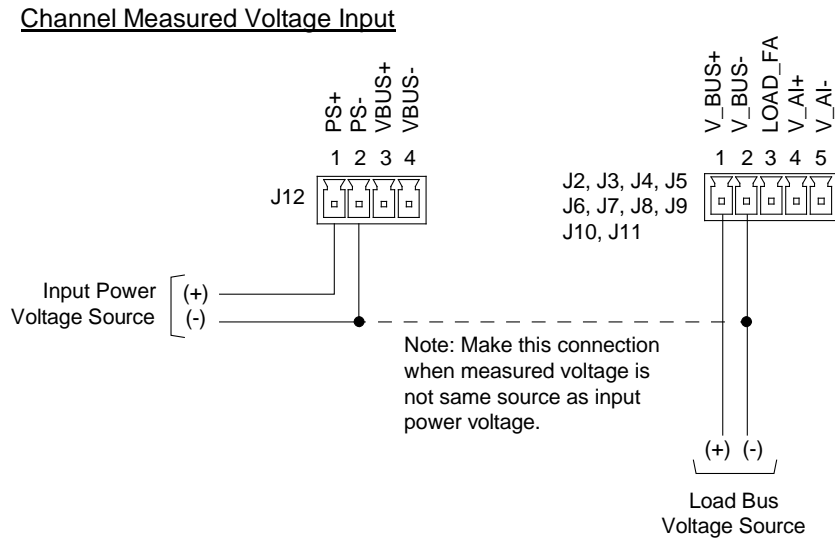
Procedure

- Refer to “Jumper Settings on SM-DUE” on page 104 and set each input block’s analog input for the type of signal being connected.
- For each input block (connectors J2, J3, J4, J5, J6, J7, J8, J9, J10, J11), connect the following signals. Refer to the next sections for specific connection details.
 - Connect the positive (+) load bus voltage monitoring lead to pin 1.
 - Connect the negative (-) load bus voltage monitoring lead to pin 2.
 - Connect the fuse alarm monitoring lead to pin 3 (Bus- base of 0 VDC, >10 VDC alarm, <10 VDC normal).
 - Connect the positive (+) analog input lead to pin 4.
 - Connect the negative (-) analog input lead to pin 5.

Load Bus Voltage Monitoring Connections

Refer to **Figure 7.11** for a wiring diagram.

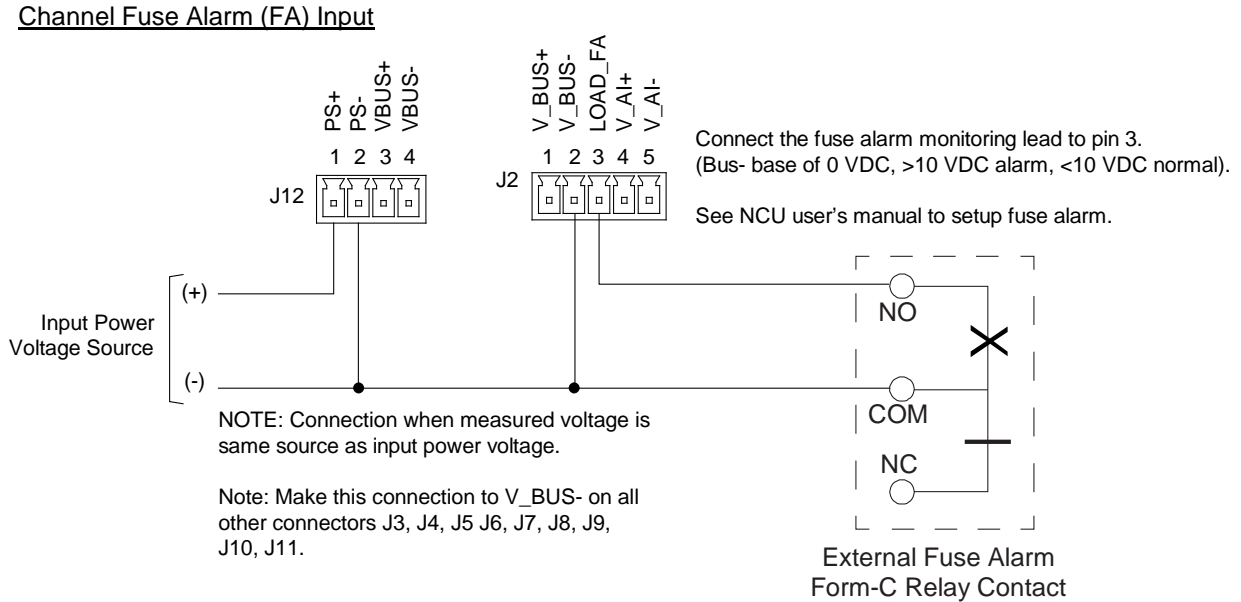
Figure 7.11 Load Bus Voltage Monitoring Connections



Load Fuse Alarm (FA) Input Connections

Refer to **Figure 7.12** for a wiring diagram.

Figure 7.12 Load Fuse Alarm Connections

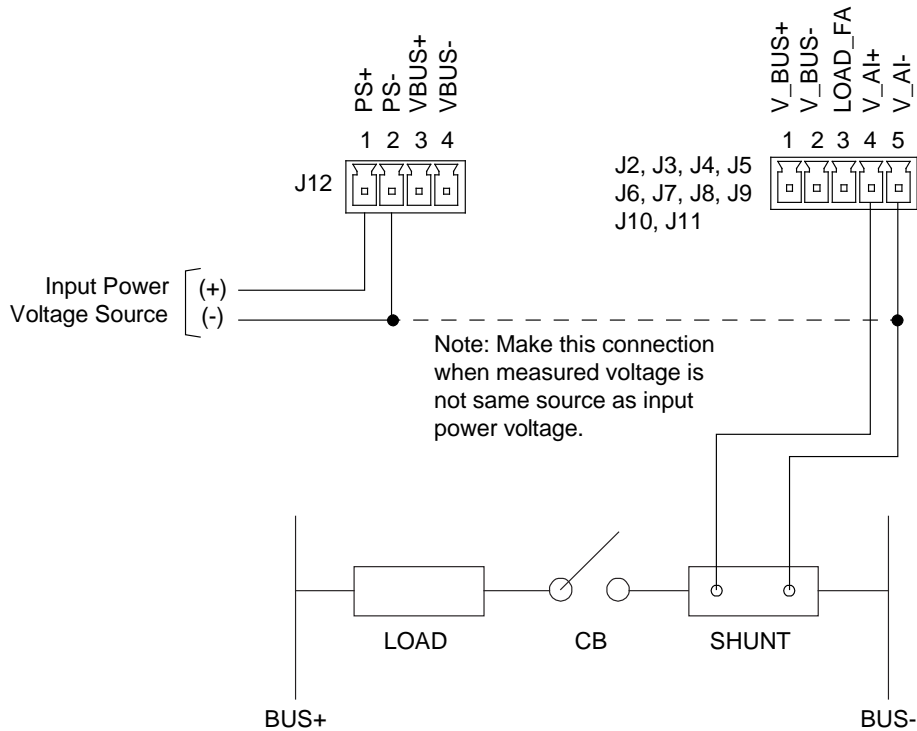
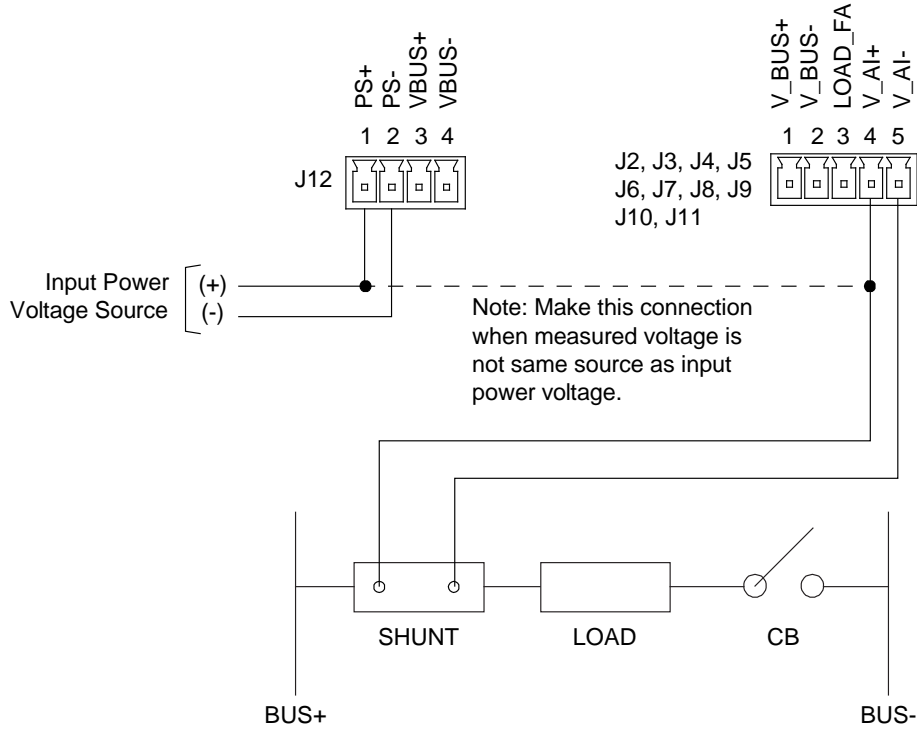


Analog Input (AI) Connections when Set for Load Shunt

Refer to **Figure 7.13** for a wiring diagram.

Figure 7.13 Analog Input (AI) Connections when Set for Load Shunt

AI Input Set to Load Shunt

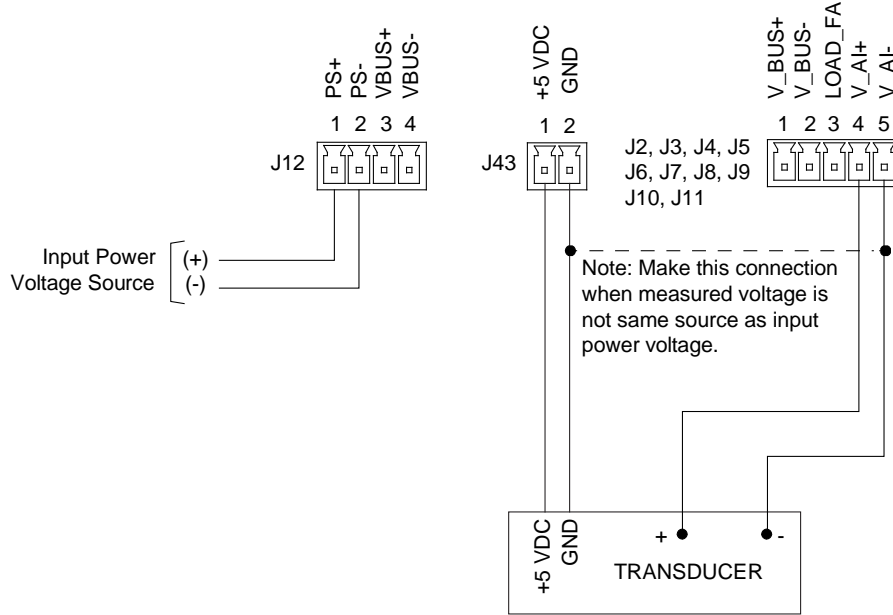


Analog Input (AI) Connections when Set for Transducer

Refer to **Figure 7.14** for a wiring diagram.

Figure 7.14 Analog Input (AI) Connections when Set for Transducer

AI Input Set to Transducer



Analog Input (AI) Connections when Set for Temperature Probe

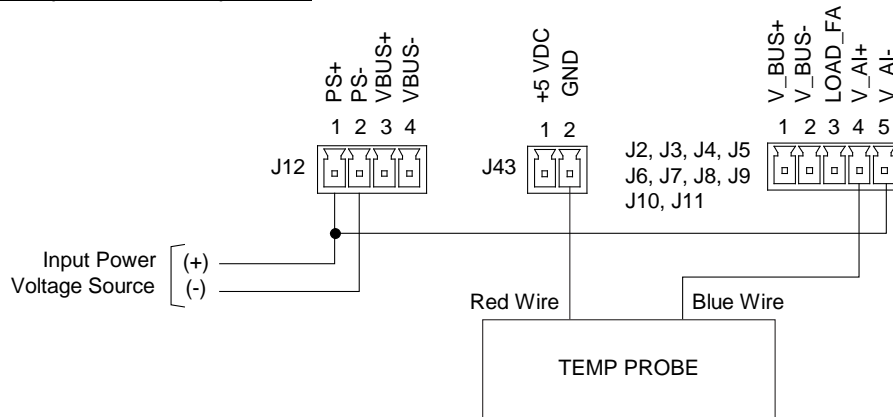
Refer to **Figure 7.15** for a wiring diagram.

NOTE! The connector end must be cut off from the temperature probe and the temperature probe hardwired into the unit.

NOTE! Only the SM DUE designated as SMDUE1 and SMDUE2 via the addressing switches can have temperature probes connected to them.

Figure 7.15 Analog Input (AI) Connections when Set for Temperature Probe

AI Input Set to Temp Probe



CAN Bus Port Connection

General

- The SM-DUE is connected into the NCU CAN Bus via connector J47. Communication between the SM-DUE and the NCU is accomplished through the CAN port (J47).
- The CAN port (J47) can also be used to interconnect multiple SM-DUE units together.
- Refer to **Table 7.11** for connector pinout information.
- Refer to **Figure 7.10** for connector location.

Table 7.11 CAN Bus Port Connector J47

Connector	Pin No.	Signal Name	Signal Symbol	Description
J47	1	CAN Communication H	CAN_H	CAN Port
	2	CAN Communication L	CAN_L	

Procedure



NOTE! The NCU can communicate with up to eight (8) SM-DUE units.

1. SM-DUE connector J47 is factory connected to the CAN port connectors located on the secondary bay's control shelf. Refer to "Bay-to-Bay Interconnections" on page 108.

7.5.8 Surge Suppression Alarms (if option installed)

If a bay is equipped with a surge suppression option, connect the remote monitoring leads from each of the two surge suppression assemblies as follows.

Procedure

1. Locate the wire harness connected to the surge suppression assemblies. Connect the leads as follows.
 - a) Connect the BROWN wire (Suppression Assembly A - COMM) to Return.
 - b) Connect the VIOLET wire (Suppression Assembly A - NC) to IB2-1 DI6(+).
 - c) Connect the YELLOW wire (Suppression Assembly B - COMM) to Return.
 - d) Connect the ORANGE wire (Suppression Assembly B - NC) to IB2-1 DI7(+).

Note that a Surge Suppression Alarm is active when there is NO AC power, and resets when AC power is supplied.

7.6 Bay Frame Grounding Connections

NOTE! Refer to System Application Guide SAG582140000 for recommended wire size and crimp lug. Lugs should be crimped per lug manufacturer's specifications. For bay grounding requirements; refer to the National Electrical Code, applicable local codes, and your specific site requirements.

Procedure

1. Located on the top of each bay are two to four sets of captive nuts (1/4-20 on 5/8" centers) or holes. Attach customer grounding network leads to these using customer supplied two-hole lugs, mounting bolts, and hardware. Recommended torque is 60 in-lbs when using 1/4-inch hardware and a Belleville lock washer. Refer to **Figure 7.16** and **Figure 7.17** for location.

Figure 7.16 Power/Distribution and Power Only Bay Frame Grounding Connection Locations

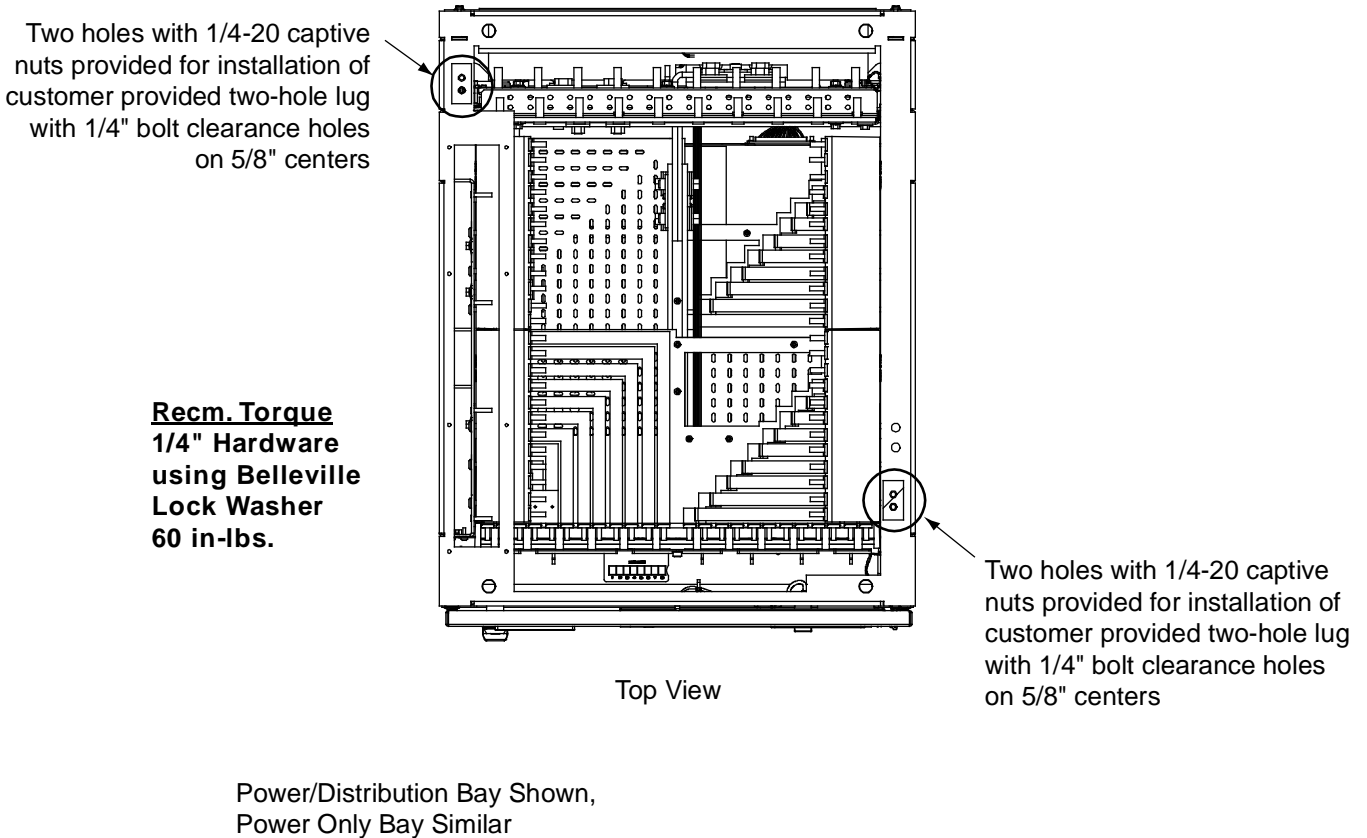
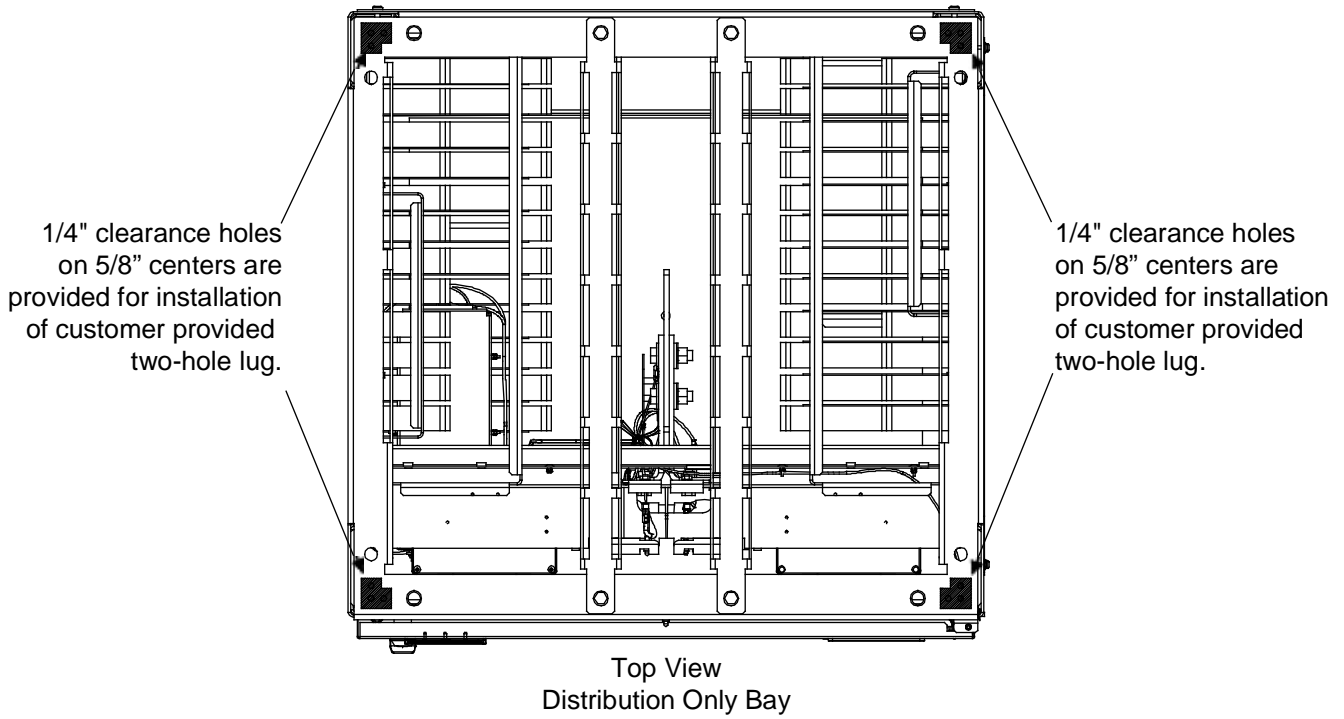


Figure 7.17 Distribution Only Bay Frame Grounding Connection Locations



Recm. Torque

**1/4" Hardware
using Belleville
Lock Washer
60 in-lbs.**

7.7 Load Connections

Important Safety Instructions



DANGER! Adhere to the “Important Safety Instructions” starting on page vii.



NOTE! Refer to System Application Guide SAG582140000 for recommended wire sizes and crimp lugs. Refer also to the SAG for maximum size of wire to connect to the various lug landing points. Lugs should be crimped per lug manufacturer’s specifications.

Power/Distribution Bay

Each power/distribution bay has two (2) distribution buses. Each distribution bus has twenty-four (24) fuse/circuit breaker device mounting positions. Note that the various fuse/circuit breaker devices require different number of mounting positions. The load side of each fuse/circuit breaker mounting position is bused up to the top of the bay. Each fuse/circuit breaker device is supplied with a load lug adapter plate that mounts to the appropriate load side busbar at the top of the bay (except bullet nose-type devices which use the existing busbar provided at the top of the bay and do not require a lug adapter plate). Load return leads are terminated outside the bay. An optional external ground busbar mounted on top of the bay is available.

Refer to **Figure 7.18** for load lug landing locations.

When lugs are secured using 1/4 inch hardware, recommended torque is 60 in-lbs when a Belleville lock washer is used, and 84 in-lbs when a standard flat washer and lock washer are used.

When lugs are secured using 3/8 inch hardware, recommended torque is 180 in-lbs when a Belleville lock washer is used, and 300 in-lbs when a standard flat washer and lock washer are used.

Load Side

Connect load leads to the respective load busbar located at the top of the bay. These busbars are provided with 1/4-20 studs and hardware on 5/8 inch centers for installation of customer provided two hole lugs. Note that for distribution devices that require more than one distribution mounting positions, lug adapter kits are furnished. The kit supplied lug adapters are provided with 3/8 clearance holes on 1 inch centers for installation of customer provided two-hole lugs. The kit also contains 1/4" and 3/8" mounting hardware.

Load Return Side

To Optional External Top-Mount Ground (Load Return) Busbar Assembly and Optional Load Return Lug Extension Busbar

Assembly: Connect load return leads to the external ground busbars mounted on top of the bays. These busbars are provided with 3/8 inch clearance holes on 1 inch centers for installation of customer provided two-hole lugs. Customer must supply lug mounting bolts and hardware (note that the Load Return Lug Extension Busbar is provided with lug mounting hardware).

To Optional Internal Ground (Load Return) Busbar Assembly: Connect load return leads to the internal ground busbars mounted inside the bays. These busbars are provided with clearance holes for installation of customer provided two hole lugs. Customer must supply lug mounting bolts and hardware. Refer to **Figure 7.19**.

Figure 7.18 Load Connections to Power/Distribution Bays (cont'd on next page)

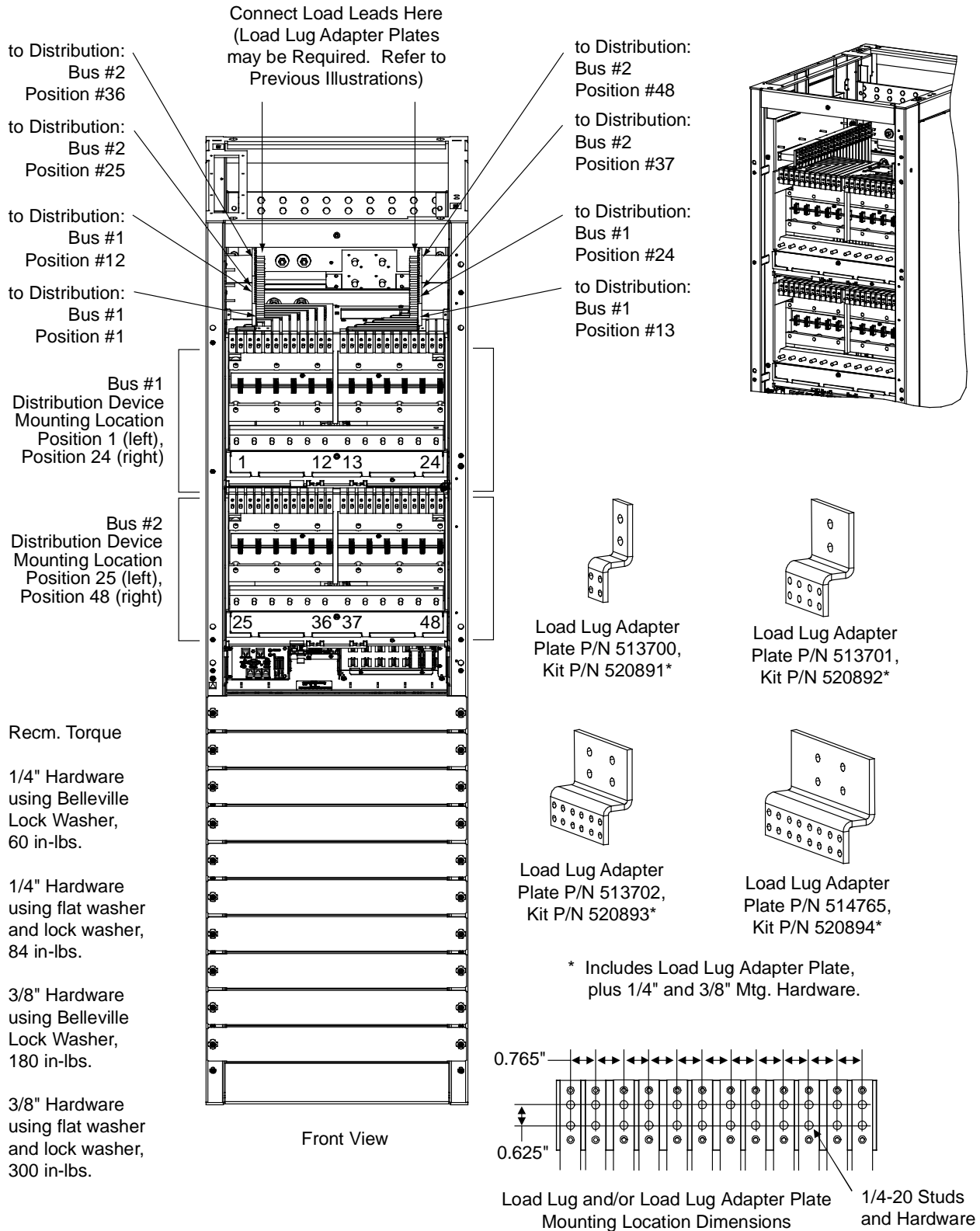
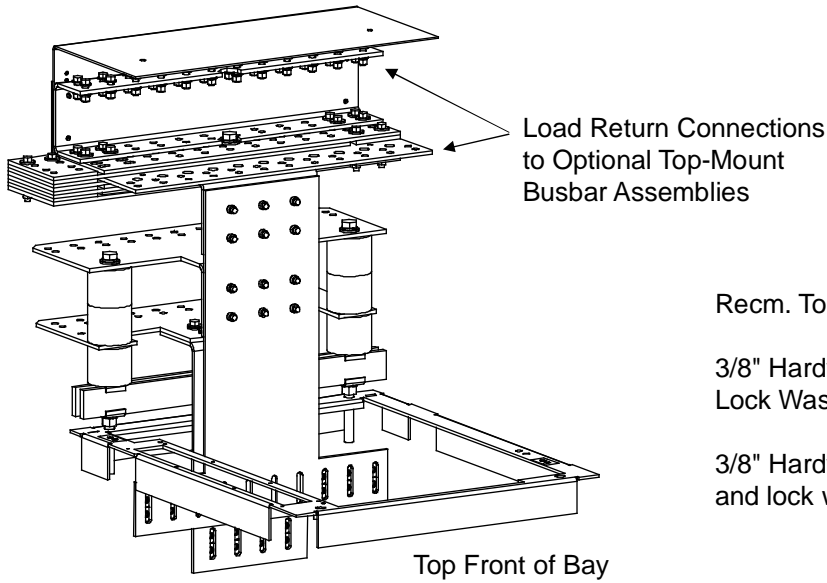


Figure 7.18 Load Connections to Power/Distribution Bays (cont'd from previous page)

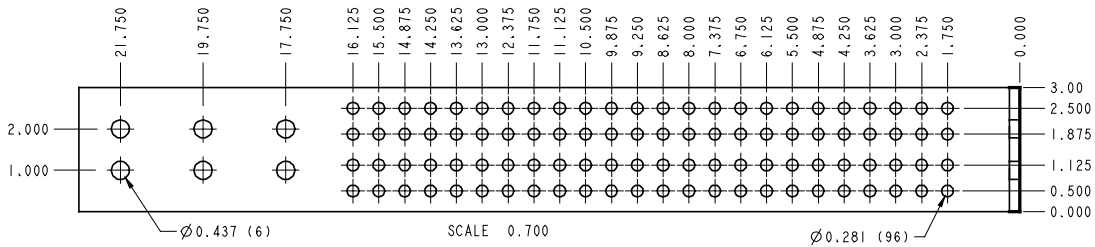
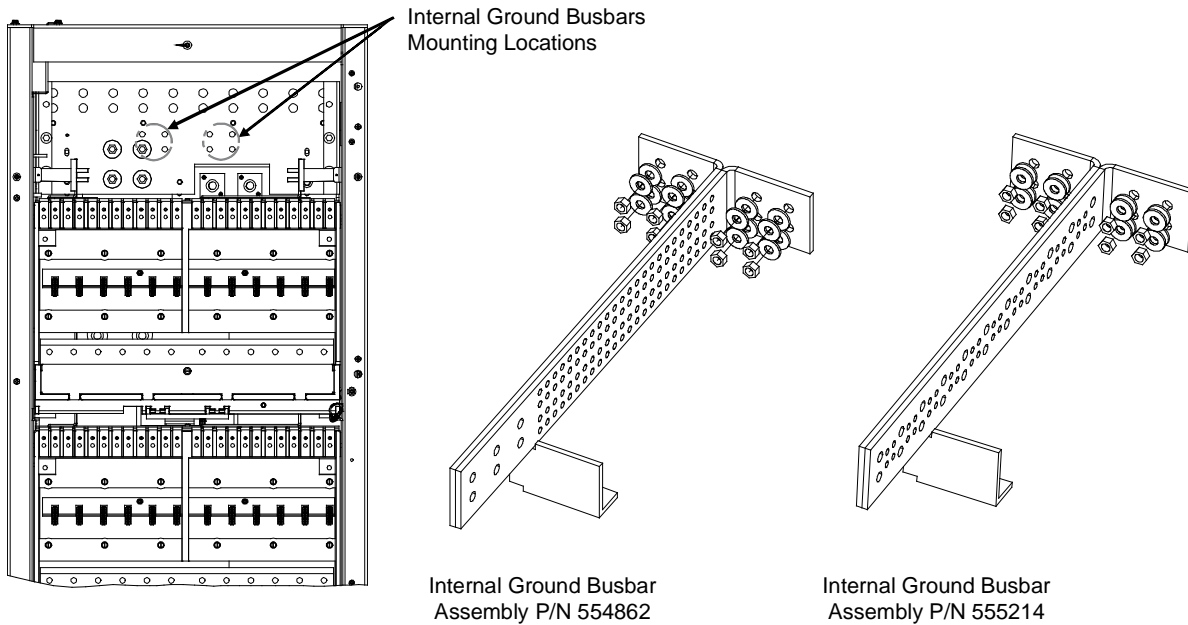


Recm. Torque

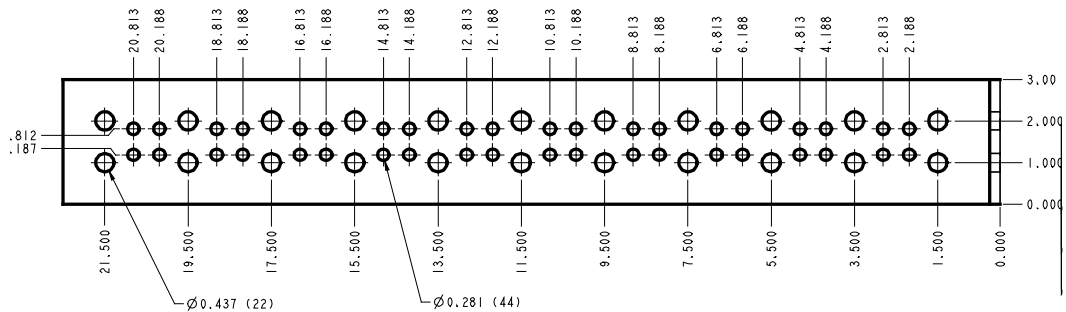
3/8" Hardware using Belleville
Lock Washer, 180 in-lbs.

3/8" Hardware using flat washer
and lock washer, 300 in-lbs.

Figure 7.19 Load Connections to Power/Distribution Bays Optional Internal Ground (Load Return) Busbar Assembly



Internal Ground Busbar Assembly P/N 554862



Internal Ground Busbar Assembly P/N 555214

Distribution Only Bay

To 218 Circuit Breakers and TPL Fuses

Each distribution only bay has four (4) distribution buses. Each distribution bus has twelve (12) fuse/circuit breaker device mounting positions. Note that the various fuse/circuit breaker devices require different number of mounting positions. The load side of each fuse/circuit breaker mounting position is bused to the rear of the bay. Each fuse/circuit breaker device requires a load lug adapter plate kit that mounts to the appropriate load side busbars at the rear of the bay (except 1-pole devices). Load return leads are terminated outside the bay to the optional external ground busbar mounted on top of the bay.

Refer to **Figure 7.20** for load lug landing locations.

When lugs are secured using 3/8 inch hardware, recommended torque is 180 in-lbs when a Belleville lock washer is used, and 300 in-lbs when a standard flat washer and lock washer are used.

Load Side

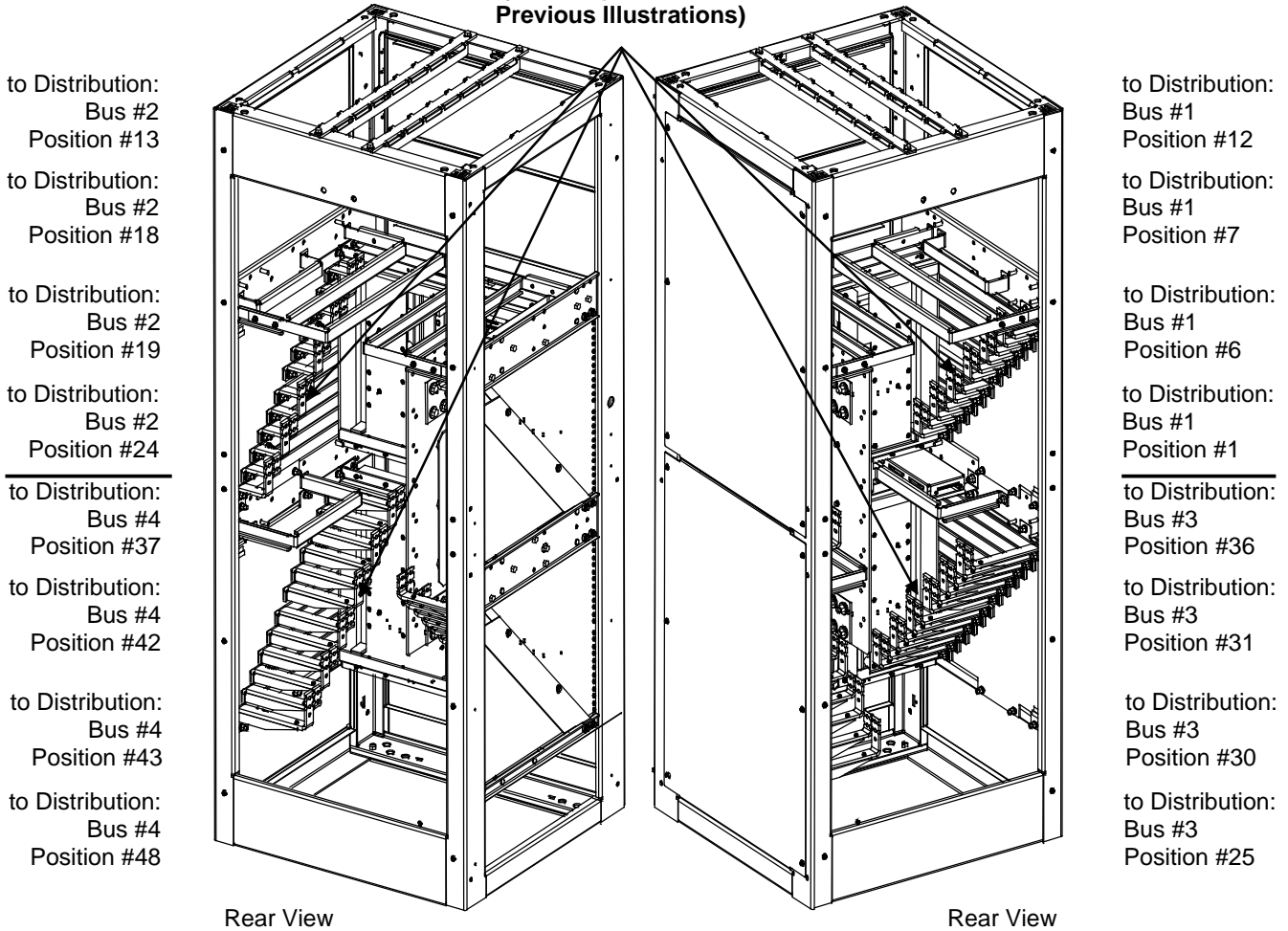
Connect load leads to the respective load busbar located at the rear of the bay. These busbars are provided with 3/8" clearance holes on 1 inch centers for installation of customer provided two hole lugs. Note that for distribution devices that require more than one distribution mounting positions, lug adapter kits are furnished, as ordered. The kit-supplied lug adapters are provided with 3/8" clearance holes on 1 inch centers for installation of customer provided two-hole lugs. The kit also contains 3/8" mounting hardware.

Load Return Side

Load return leads are terminated outside the bay to customer provided return busbars.

Figure 7.20 Load Connections to 218 Circuit Breakers and TPL Fuses

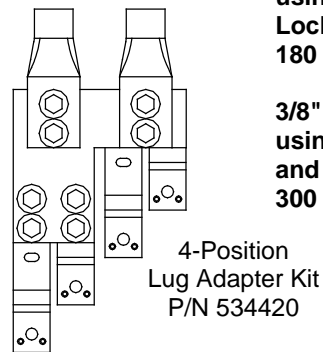
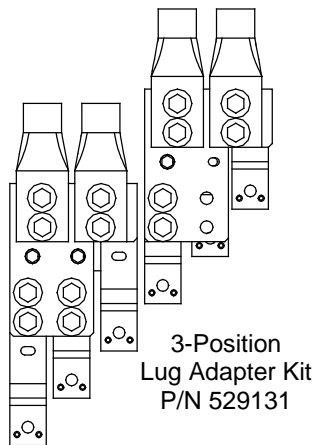
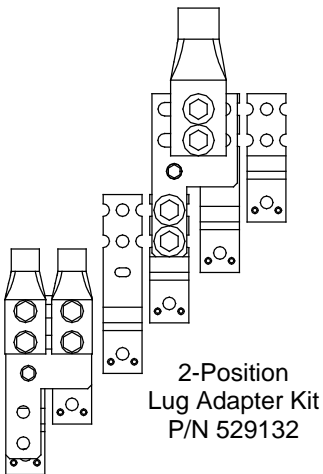
**Connect Load Leads Here
(Load Lug Adapter Plates
May Be Required, Refer to
Previous Illustrations)**



Rear View

Rear View

Rear cover panels removed in illustration for clarity.



Recm. Torque

**3/8" Hardware
using Belleville
Lock Washer,
180 in-lbs**

**3/8" Hardware
using flat washer
and lock washer,
300 in-lbs**

To Optional Bullet Device Panel (TLS/TPS Fuses and Bullet Nose-Type Circuit Breakers)

Refer to **Figure 7.21** for load lug landing locations.

When lugs are secured using 1/4 inch hardware, recommended torque is 60 in-lbs when a Belleville lock washer is used, and 84 in-lbs when a standard flat washer and lock washer are used.

Load Side

Connect load leads to the busbars provided on the List C Fuse/Circuit Breaker Panel. These busbars provide 1/4-20 threaded holes on 5/8" centers for installation of customer provided two-hole lugs.

Customer must provide lug mounting bolts and additional hardware.

Bolt length: 3/4".

Load Return Side

Load return leads are terminated outside the bay to customer provided return busbars.

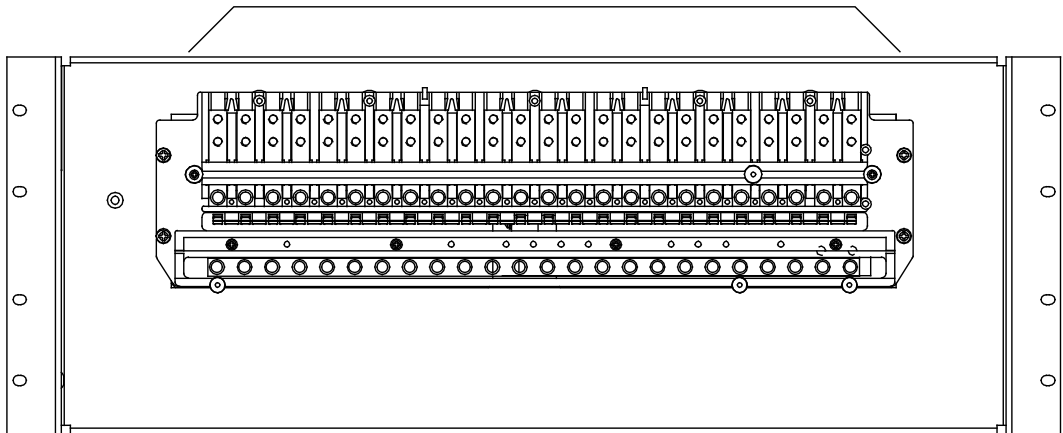
Figure 7.21 Load Connections to Optional Bullet Device Panel (TLS/TPS Fuses and Bullet Nose-Type Circuit Breakers)

Note: Load leads are connected to load busbars. These busbars provide 1/4-20 threaded holes on 5/8" centers for installation of customer provided two-hole lugs. Customer must provide lug mounting bolts and additional hardware. Bolt length: 3/4".

Recm. Torque

**1/4" Hardware
using Belleville
Lock Washer,
60 in-lbs**

**1/4" Hardware
using flat washer
and lock washer,
84 in-lbs**



Installing and Wiring an Optional Bullet Nose-Type 10-Position GMT Fuse Module (P/N 509128)

Installing

Each optional Bullet Nose-Type 10-Position GMT Fuse Module plugs into 'distribution device' mounting positions of a List C Fuse/Circuit Breaker Panel. Each GMT Fuse Module requires five (5) bullet device mounting positions. See **Figure 7.22**.

1. Install the GMT Fuse Module in the desired position oriented as shown in **Figure 7.22**.
2. Connect a customer provided ground lead from the List C Fuse/Circuit Breaker Panel lug mounting busbar associated to the GMT Fuse Module mounting position (far left or far right most lug mounting position) to the system's ground/return busbar. Recommended wire size is 10 AWG. Refer to **Figure 7.22**.



NOTE! *The ground lead will be installed in a position normally used for -48V distribution. It is recommended to use a Green lead and insulate the connection with shrink tubing to avoid incidental contact.*

3. Install an appropriately sized GMT-type fuse in each fuse mounting position F1-F10 on the module. If dummy fuses are installed, remove them first.
4. Verify dummy fuses are installed in all unused positions of the GMT Fuse Module.
5. Verify fuse F11 is a Bussmann GMT 18/100 Amp alarm fuse.
6. Verify fuse safety covers are installed over all fuses.

Wiring

Connections are made to the terminal blocks located on the optional Bullet Nose-Type 10-Position GMT Fuse Module as shown in **Figure 7.22**. Wires are connected to the terminals by inserting the stripped wire into the wire opening, and then tightening the screw. The wires should be checked for proper installation by gently attempting to pull the wires from the terminal. The terminal block accepts a wire size in the range of 24 to 14 AWG. Recommended torque is 5.0 in-lbs.

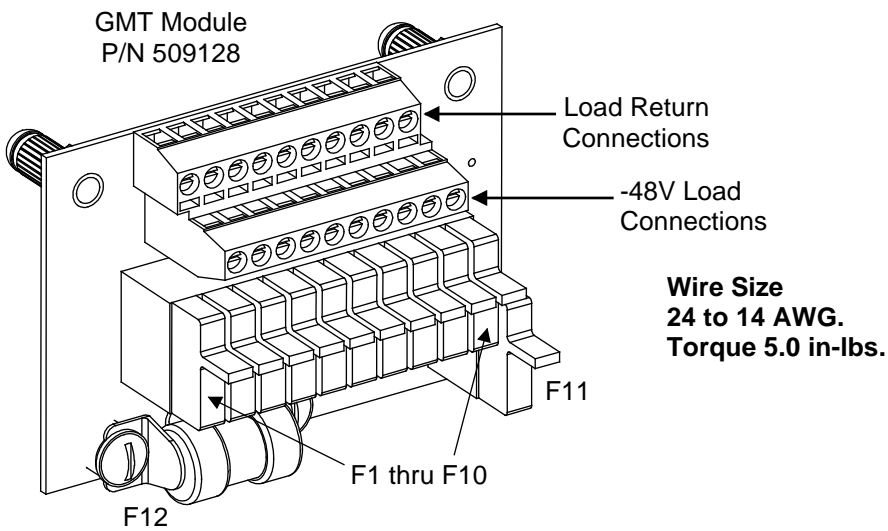
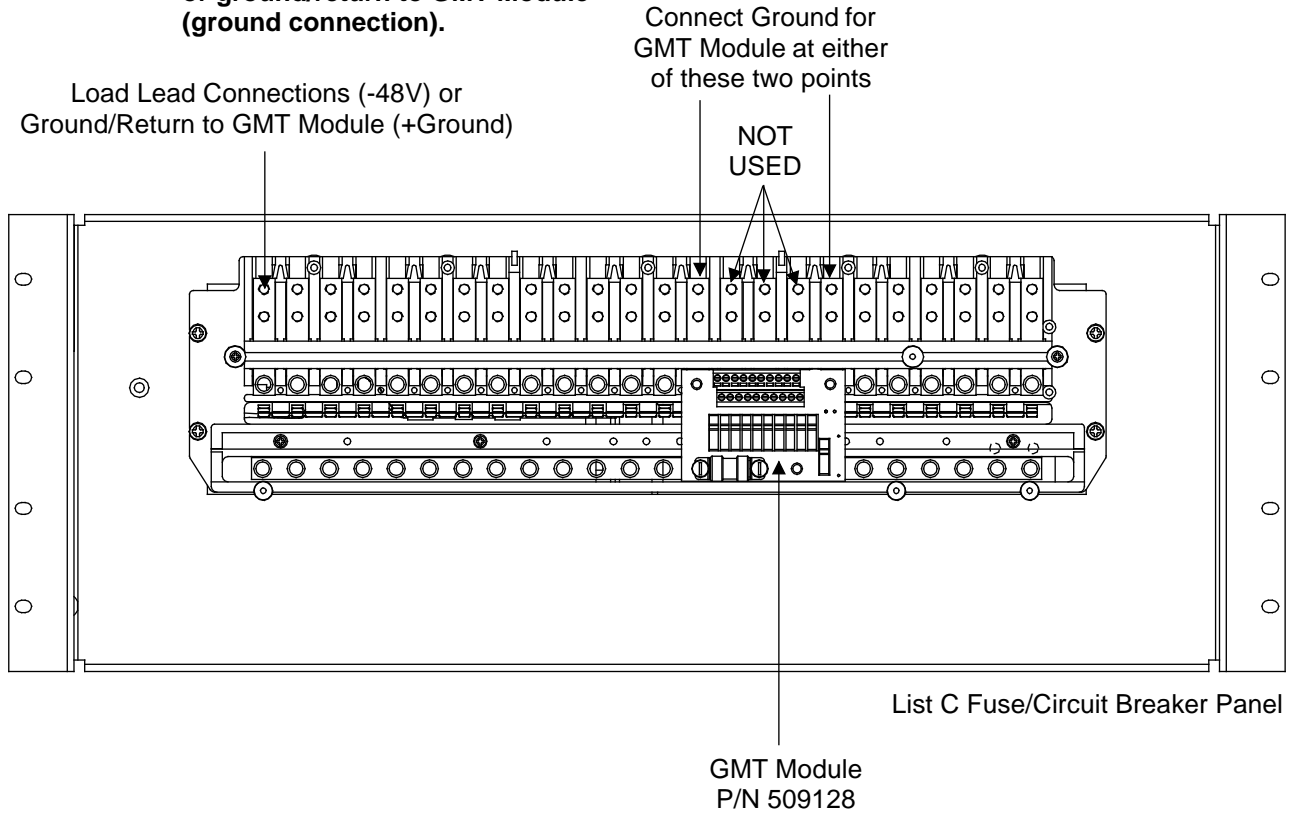
30A MAXIMUM CAPACITY PER BLOCK.

SEE SAG582140000 FOR ADDITIONAL RESTRICTIONS

Figure 7.22 Installing and Wiring an Optional Bullet Nose-Type 10-Position GMT Fuse Module (P/N 509128)

DANGER

Ensure leads are connected to proper polarity for the device installed, either a Distribution Device (load lead connection) or ground/return to GMT Module (ground connection).



7.8 AC Input and AC Input Ground Connections

Important Safety Instructions



DANGER! Adhere to the “Important Safety Instructions” starting on page vii.



NOTE! Refer to System Application Guide SAG582140000 for recommended wire size, branch circuit protection, and crimp lugs. Refer also to the SAG for maximum size of wire to connect to the various lug landing points. Lugs should be crimped per lug manufacturer’s specifications.

- PDSC = AC Input 'Power Distribution Service Cabinet'.



NOTE! Please note that List 35, List 36, List 37, and List 38 Transient Voltage Surge Protector (TVSS) units designed to be used with solidly grounded electrical systems and are not compatible with High Resistance Grounding for electrical systems. On a HRG system, L-G voltage rises to the rated line voltage during a bolted ground fault. At this voltage the TVSS which is expecting to see a Line to Neutral Voltage would read a Line to Line Voltage across it, which would stress the TVSS and eventually cause the TVSS to fail.

Wiring Routing Guidelines

Lists 101 and 111 Bays (w/out PDSC): Ten circular openings are provided in the top of each bay for AC input and AC input grounding conductors. Conduit adapter plates are also furnished. These adapter plates accept 3/4" or 1" inch conduit fittings. Conduit fittings should be installed, and AC input and AC input grounding conductors should be routed into the cabinet through these openings.

Lists 102 and 112 Bays (with PDSC): Three wiring access plates are secured to the top of the PDSC to provide a choice of wiring access openings. Choose one of the plates, and remove the two not needed. Conduit fittings should be installed, and AC input and AC input grounding conductors should be routed into the cabinet through these openings.

Lists 103 and 113 Bays: Six circular openings are provided in the top of each bay for AC input and AC input grounding conductors. Conduit adapter plates are also furnished. These adapter plates accept 1.75" inch conduit fittings. Conduit fittings should be installed, and AC input and AC input grounding conductors should be routed into the cabinet through these openings.

Lists 104 and 114 Bays: Two circular openings are provided in the top of each bay for AC input and AC input grounding conductors. Conduit adapter plates are also furnished. These adapter plates accept 1" inch conduit fittings. Conduit fittings should be installed, and AC input and AC input grounding conductors should be routed into the cabinet through these openings.

Lists 105 and 115 Bays: Ten circular openings are provided in the top of each bay for AC input and AC input grounding conductors. Conduit adapter plates are also furnished. These adapter plates accept 3/4" or 1" inch conduit fittings. Conduit fittings should be installed, and AC input and AC input grounding conductors should be routed into the cabinet through these openings.

AC Input Connections to Lists 101 and 111 Bays (w/out PDSC)

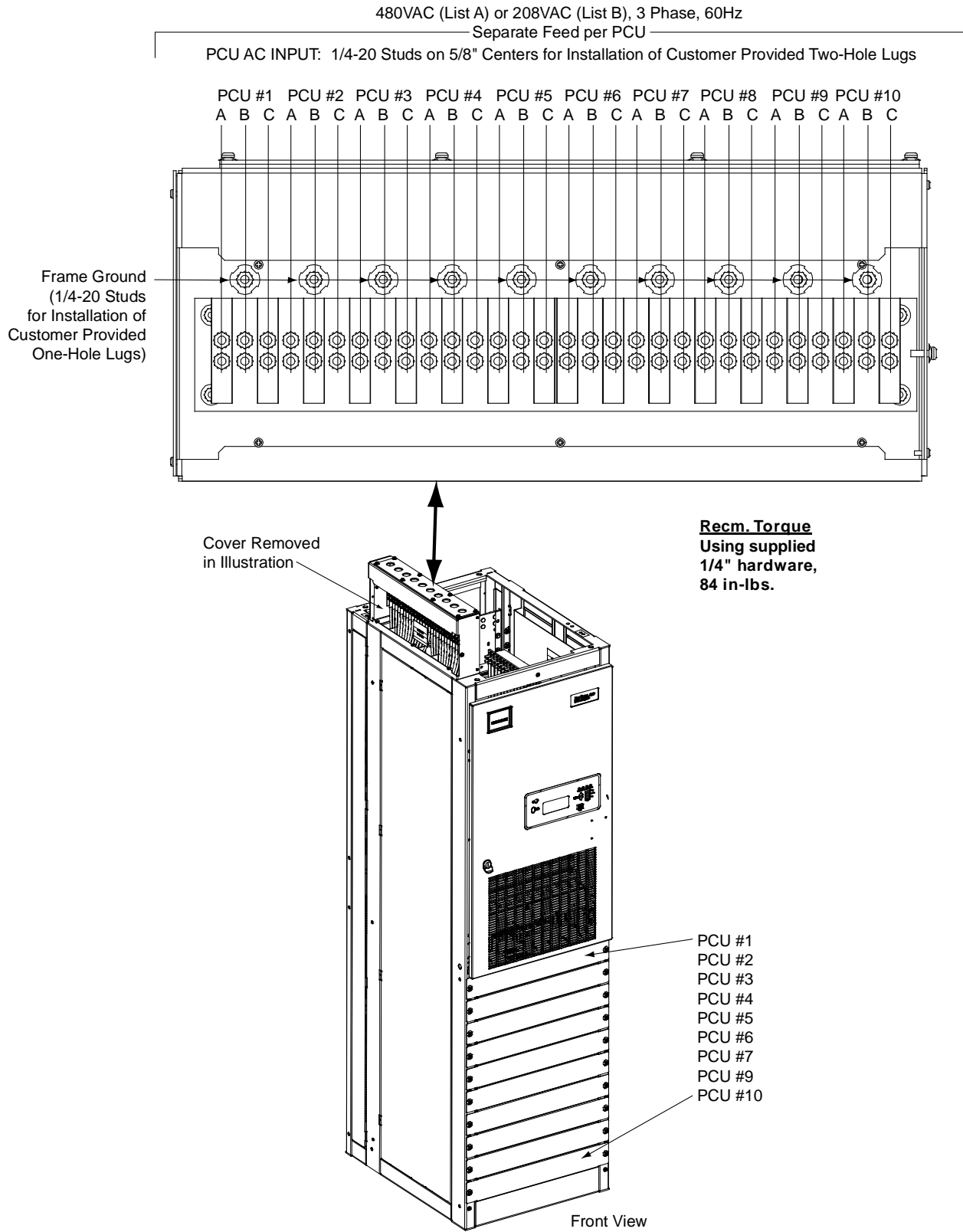
Lists 101 and 111 bays provide connections for up to 10 AC input branch circuits, one per rectifier mounting position. Customer is to provide AC input branch circuit protection.

Refer to **Figure 7.23** for lug landing locations.

Procedure

1. Refer to **Figure 7.23** and locate the rectifier AC input busbars. Remove the cover panel to gain access to these terminals.
2. The rectifier AC input busbars are equipped with 1/4-20 studs on 5/8 inch centers. Attach rectifier AC input leads to these using customer supplied two-hole lugs. When lugs are secured using 1/4-20 hardware, recommended torque is 84 in-lbs when a standard flat washer and lock washer are used.
3. Connect Phase A to the terminal designated "A". Connect Phase B to the terminal designated "B". Connect Phase C to the terminal designated "C".
4. Note that rectifier mounting positions are numbered 1 through 10, starting at the top of the bay.
5. Equipment grounding conductors must be provided with the AC input conductors supplied to each bay. Connect to earth ground, not power system neutral.
6. Refer to **Figure 7.23** and locate the rectifier AC input frame ground studs (1/4-20 studs). Attach rectifier AC input ground leads to these studs using customer supplied one-hole lugs. When lugs are secured using 1/4-20 hardware, recommended torque is 84 in-lbs when a standard flat washer and lock washer are used.
7. Replace the terminal access panel.

Figure 7.23 AC Input and AC Input Ground Connections (Lists 101 and 111 Bays, w/out PDSC)



AC Input Connections to Lists 102 and 112 Bays (with PDSC)

Each List 102 and 112 bays must be equipped with a List 130 or 131 PDSC. The PDSC provides connections for one or two AC input branch circuits.

- ❑ Ensure that each bay is wired into the PDSC as detailed in the "Placing the Bays and Installing Internal/External Busbars" starting on page 3.

Refer to **Figure 8.1** or **Figure 8.2** for lug landing locations.

Single AC Input Feed

The two AC input circuits in the PDSC are internally bussed together to provide a single AC input for all 10 rectifier mounting positions. This is the factory setting. The linking busbars may easily be removed in the field to provide dual input circuits as described in the next procedure. An AC input circuit breaker is provided for each rectifier mounting position.

Procedure

1. Remove the rear upper cover panel from the PDSC. **To do so:** Loosen the four screws that secure each cover panel. Lift the cover panel until the screw heads clear the keyhole slots. Remove the cover panel.
2. Refer to **Figure 8.1** and locate the rectifier AC input busbars. These busbars are equipped with 3/8-16 studs on 1 inch centers. Attach rectifier AC input leads to these using customer supplied two-hole lugs and mounting hardware. When lugs are secured using 3/8 inch hardware; recommended torque is 180 in-lbs when a Belleville lock washer is used, and 300 in-lbs when a standard flat washer and lock washer are used.
3. Connect Phase A to the terminal designated "A". Connect Phase B to the terminal designated "B". Connect Phase C to the terminal designated "C".
4. Note that rectifier mounting positions are numbered 1 through 10, starting at the top of the bay.
5. Equipment grounding conductors must be provided with the AC input conductors supplied to each bay. Connect to earth ground, not power system neutral.
6. Refer to **Figure 8.1** and locate the rectifier AC input frame ground nuts (3/8-16 nuts on 1 inch centers for securing lugs and lug mounting hardware). Attach rectifier AC input ground leads to these nuts using customer supplied two-hole lugs. When lugs are secured using 3/8 inch hardware; recommended torque is 180 in-lbs when a Belleville lock washer is used, and 300 in-lbs when a standard flat washer and lock washer are used.
7. Replace the rear upper cover panel to the PDSC. **To do so:** Place the keyhole slots in the cover panel over the screws in the PDSC, slide the cover panel down and secure by tightening the screws. Use the supplied grounding washers at the top left and bottom right locations.

Dual AC Input Feed

Five rectifier mounting positions are internally bused to AC input branch circuit #1, and the remaining five rectifier mounting positions are internally bused to AC input branch circuit #2. An AC input circuit breaker is provided for each rectifier mounting position.

Procedure

1. Remove the rear upper cover panel from the PDSC. To do so: Loosen the four screws that secure each cover panel. Lift the cover panel until the screw heads clear the keyhole slots. Remove the cover panel.
2. Remove the linking busbar from the terminal designated "Feed 1 Phase A" and "Feed 2 Phase A". The busbar is not used in dual feed applications.
3. Remove the linking busbar from the terminal designated "Feed 1 Phase B" and "Feed 2 Phase B". The busbar is not used in dual feed applications.
4. Remove the linking busbar from the terminal designated "Feed 1 Phase C" and "Feed 2 Phase C". The busbar is not used in dual feed applications.
5. **Feed 1:** Refer to **Figure 8.2** and locate the rectifier AC input busbars for Feed #1. These busbars are equipped with 3/8-16 studs on 1 inch centers. Attach rectifier AC input leads to these using customer supplied two-hole lugs. When lugs are secured using 3/8 inch hardware; recommended torque is 180 in-lbs when a Belleville lock washer is used, and 300 in-lbs when a standard flat washer and lock washer are used.

Connect Phase A to the terminal designated "A". Connect Phase B to the terminal designated "B". Connect Phase C to the terminal designated "C".

Feed 2: Refer to **Figure 8.2** and locate the rectifier AC input busbars for Feed #2. These busbars are equipped with 3/8-16 studs on 1 inch centers. Attach rectifier AC input leads to these using customer supplied two-hole lugs. When lugs are secured using 3/8 inch hardware; recommended torque is 180 in-lbs when a Belleville lock washer is used, and 300 in-lbs when a standard flat washer and lock washer are used.

Connect Phase A to the terminal designated "A". Connect Phase B to the terminal designated "B". Connect Phase C to the terminal designated "C".

6. Equipment grounding conductors must be provided with the AC input conductors supplied to each bay. Connect to earth ground, not power system neutral.

Refer to **Figure 8.2** and locate the rectifier AC input frame ground nuts (3/8-16 nuts on 1 inch centers for securing lugs and lug mounting hardware). Attach rectifier AC input ground leads to these nuts using customer supplied two-hole lugs. When lugs are secured using 3/8 inch hardware; recommended torque is 180 in-lbs when a Belleville lock washer is used, and 300 in-lbs when a standard flat washer and lock washer are used.

7. Replace the rear upper cover panel to the PDSC. **To do so:** Place the keyhole slots in the cover panel over the screws in the PDSC, slide the cover panel down and secure by tightening the screws. Use the supplied grounding washers at the top left and bottom right locations.

Figure 8.24 AC Input and AC Input Ground Connections (Lists 102 and 112 Bays, with PDSC) Single AC Feed

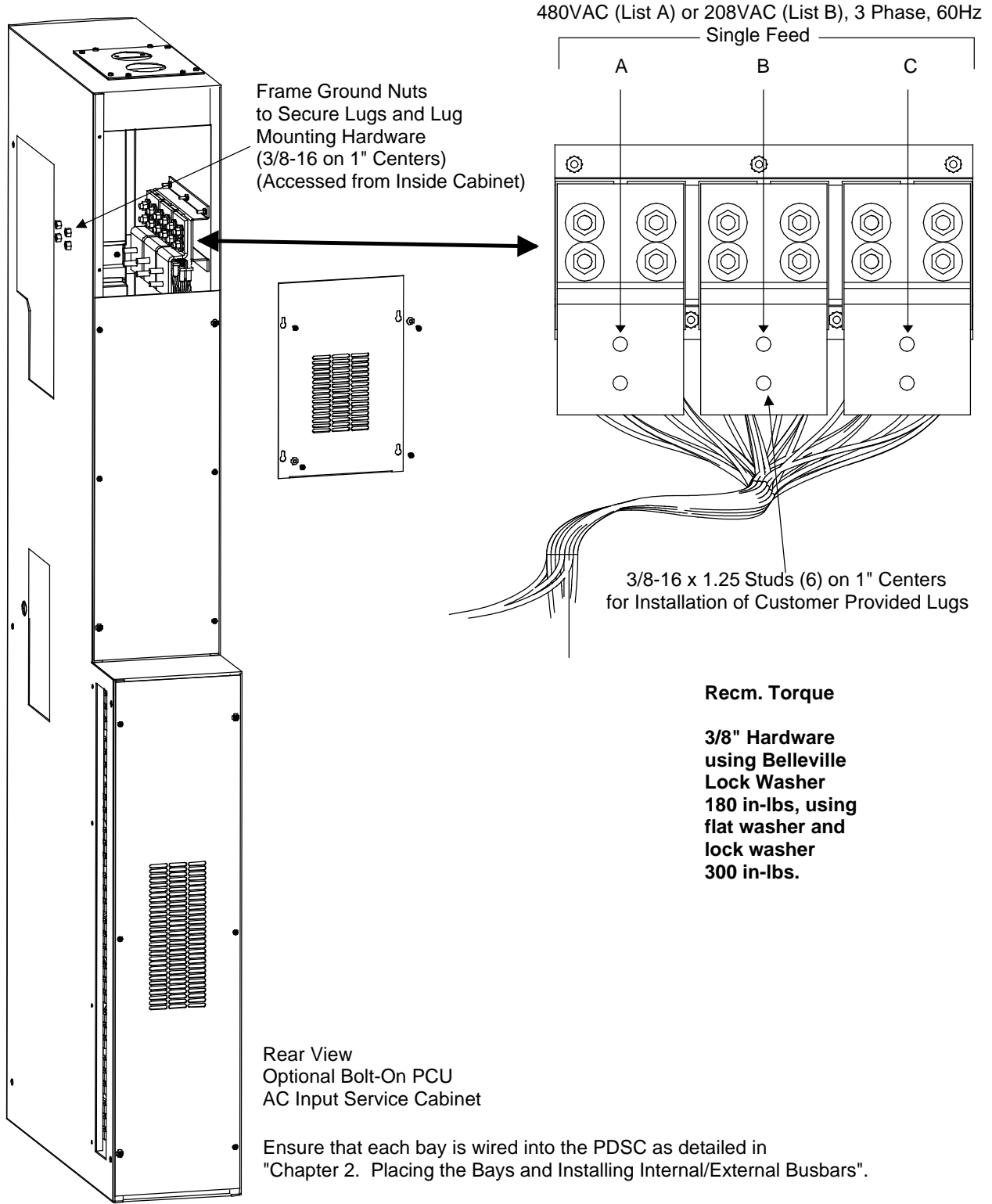
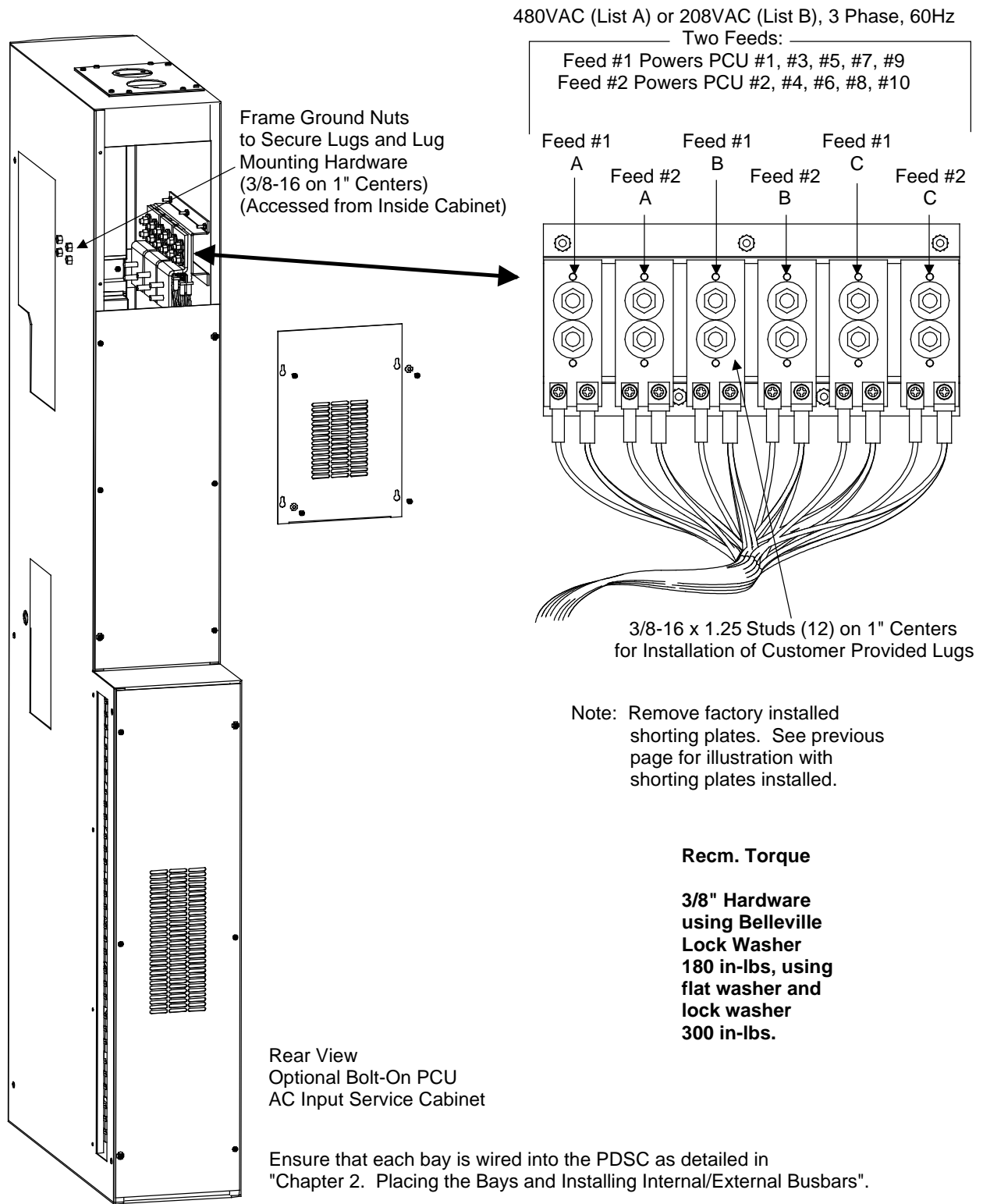


Figure 8.25 AC Input and AC Input Ground Connections (Lists 102 and 112 Bays, with PDSC) Dual AC Feed



AC Input Connections to Lists 103 and 113 Bays

Lists 103 and 113 bays provide connections for five (5) AC input branch circuits. Customer is to provide AC input branch circuit protection.

Refer to **Figure 8.3** for lug landing locations.

Procedure

1. Open the bay's front door.
2. Refer to **Figure 8.3** and locate the rectifier AC input busbars.
3. The rectifier AC input busbars are equipped with 3/8-16 studs on 1 inch centers. Attach rectifier AC input leads to these using customer supplied two-hole lugs. When lugs are secured using 3/8 inch hardware; recommended torque is 180 in-lbs when a Belleville lock washer is used, and 300 in-lbs when a standard flat washer and lock washer are used.

Connect Phase A to the terminal designated "A". Connect Phase B to the terminal designated "B". Connect Phase C to the terminal designated "C".

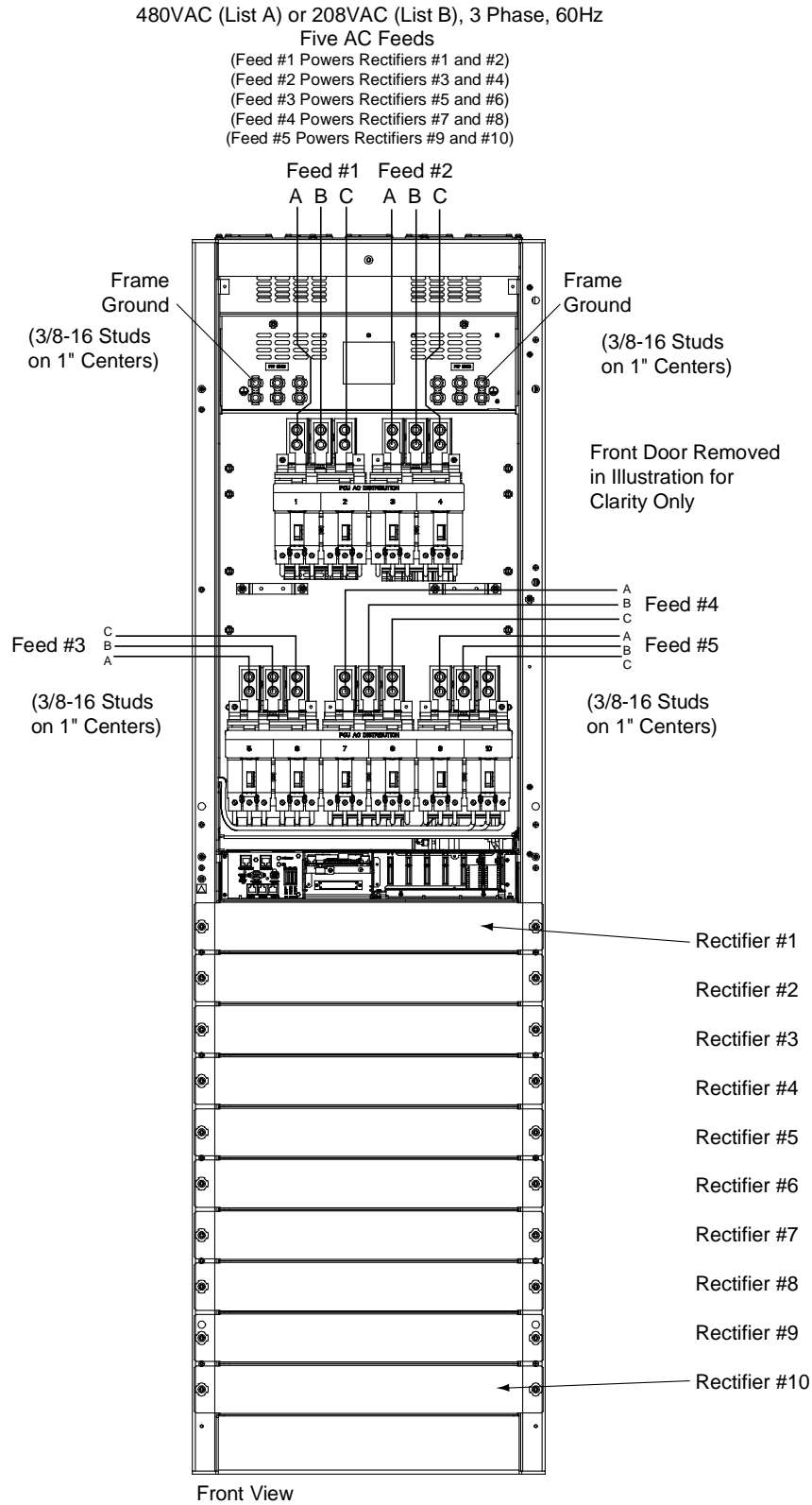
Note that rectifier mounting positions are numbered 1 through 10, starting at the top of the bay.

4. Equipment grounding conductors must be provided with the AC input conductors supplied to each bay. Connect to earth ground, not power system neutral.

Refer to **Figure 8.3** and locate the rectifier AC input frame ground studs (3/8-16 studs on 1 inch centers). Attach rectifier AC input ground leads to these studs using customer supplied two-hole lugs. When lugs are secured using 3/8 inch hardware; recommended torque is 180 in-lbs when a Belleville lock washer is used, and 300 in-lbs when a standard flat washer and lock washer are used.

5. Close the bay's front door.

Figure 8.26 AC Input and AC Input Ground Connections (Lists 103 and 113 Bays, Five AC Feeds)



AC Input Connections to Lists 104 and 114 Bays

Lists 104 and 114 bays provide connections for two (2) AC input branch circuits. Customer is to provide AC input branch circuit protection.

Refer to **Figure 8.4** for lug landing locations.

Procedure

1. Open the bay's front door.
2. Refer to **Figure 8.4** and locate the rectifier AC input busbars.
3. The rectifier AC input busbars are equipped with 3/8-16 studs on 1 inch centers. Attach rectifier AC input leads to these using customer supplied two-hole lugs. When lugs are secured using 3/8 inch hardware; recommended torque is 180 in-lbs when a Belleville lock washer is used, and 300 in-lbs when a standard flat washer and lock washer are used.

Connect Phase A to the terminal designated "A". Connect Phase B to the terminal designated "B". Connect Phase C to the terminal designated "C".

Note that rectifier mounting positions are numbered 1 through 10, starting at the top of the bay.

4. Equipment grounding conductors must be provided with the AC input conductors supplied to each bay. Connect to earth ground, not power system neutral.

Refer to **Figure 8.4** and locate the rectifier AC input frame ground studs (3/8-16 studs on 1 inch centers). Attach rectifier AC input ground leads to these studs using customer supplied two-hole lugs. When lugs are secured using 3/8 inch hardware; recommended torque is 180 in-lbs when a Belleville lock washer is used, and 300 in-lbs when a standard flat washer and lock washer are used.

5. Close the bay's front door.

AC Input Connections to Lists 105 and 115 Bays

Lists 105 and 115 bays provide connections for ten (10) AC input branch circuits. Customer is to provide AC input branch circuit protection.

Refer to **Figure 8.5** for lug landing locations.

Procedure

1. Open the bay's front door.
2. Refer to **Figure 8.5** and locate the rectifier AC input busbars.
3. The rectifier AC input busbars are equipped with 1/4-20 studs on 5/8 inch centers. Attach rectifier AC input leads to these using customer supplied two-hole lugs. When lugs are secured using 1/4 inch hardware, recommended torque is 84 in-lbs when a standard flat washer and lock washer are used.

Connect Phase A to the terminal designated "A". Connect Phase B to the terminal designated "B". Connect Phase C to the terminal designated "C".

Note that rectifier mounting positions are numbered 1 through 10, starting at the top of the bay.

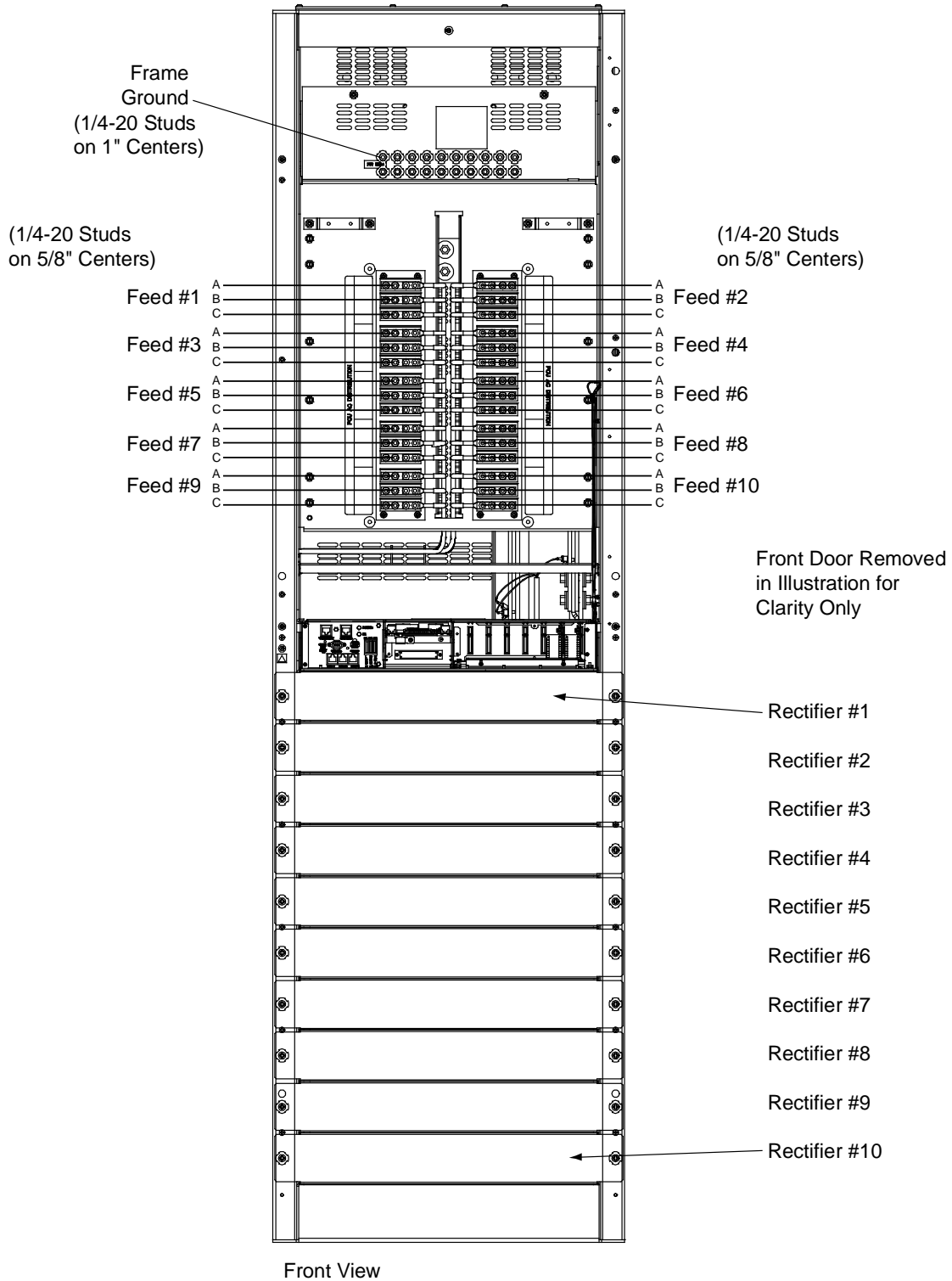
4. Equipment grounding conductors must be provided with the AC input conductors supplied to each bay. Connect to earth ground, not power system neutral.

Refer to **Figure 8.5** and locate the rectifier AC input frame ground studs (1/4-20 studs). Attach rectifier AC input ground leads to these studs using customer supplied one-hole lugs. When lugs are secured using 1/4 inch hardware, recommended torque is 84 in-lbs when a standard flat washer and lock washer are used.

5. Close the bay's front door.

Figure 8.28 AC Input and AC Input Ground Connections (Lists 105 and 115 Bays, Ten AC Feeds)

480VAC (List A) or 208VAC (List B), 3 Phase, 60Hz
Ten AC Feeds



7.9 Battery Connections

Important Safety Instructions



DANGER! Adhere to the “Important Safety Instructions” starting on page vii.



NOTE! Refer to *System Application Guide SAG582140000* for recommended wire sizes and crimp lugs. Lugs should be crimped per lug manufacturer’s specifications.

Power/Distribution Bay

To Power/Distribution Bay

Located on the rear top of each bay are studs (3/8-16 on 1" centers). Attach battery leads to these using customer supplied two-hole lugs and mounting hardware. When lugs are secured using 3/8 inch bolts; recommended torque is 180 in-lbs when a Belleville lock washer is used, and 300 in-lbs when a standard flat washer and lock washer are used.

Refer to **Figure 8.6** for battery landing locations.

The System's Positive Battery Busbar must be grounded. Refer to the National Electrical Code, applicable local codes, and your specific site requirements for grounding specifications.

To Overhead Battery Busbars

If installed, connect battery leads to optional overhead battery busbars. These busbars are provided with 3-8 inch clearance holes on 1 inch centers. Attach battery leads to these using customer supplied two-hole lugs, mounting bolts, and hardware. When lugs are secured using 3/8 inch bolts; recommended torque is 180 in-lbs when a Belleville lock washer is used, and 300 in-lbs when a standard flat washer and lock washer are used.

Refer to **Figure 8.7** and **Figure 8.8** for battery landing locations.

The System's Positive Battery Busbar must be grounded. Refer to the National Electrical Code, applicable local codes, and your specific site requirements for grounding specifications.

Figure 8.29 Battery Connection to Rear of Power/Distribution Bay

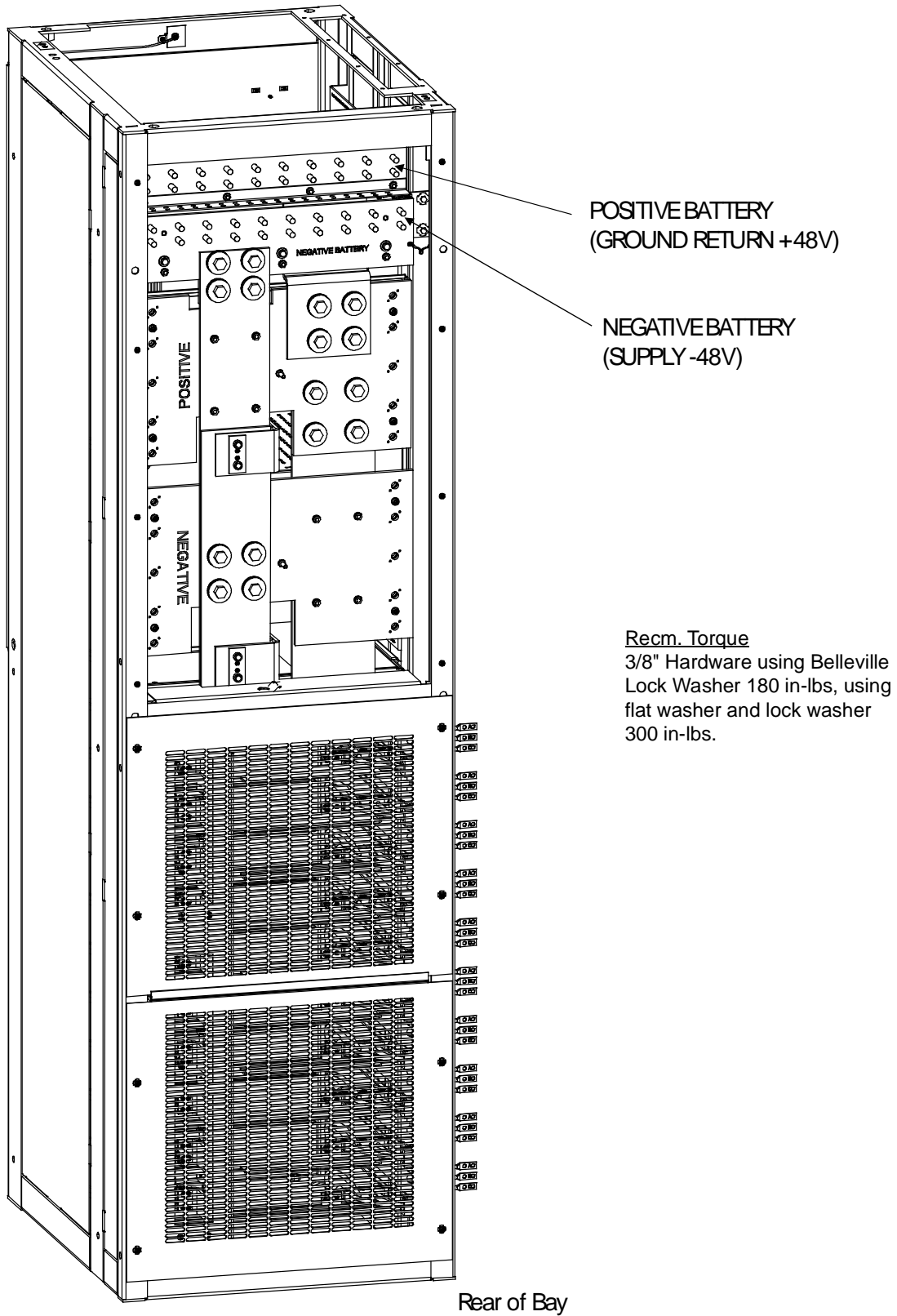


Figure 8.30 Battery Connection to Optional Horizontal Battery Termination Assembly on Power/Distribution Bays

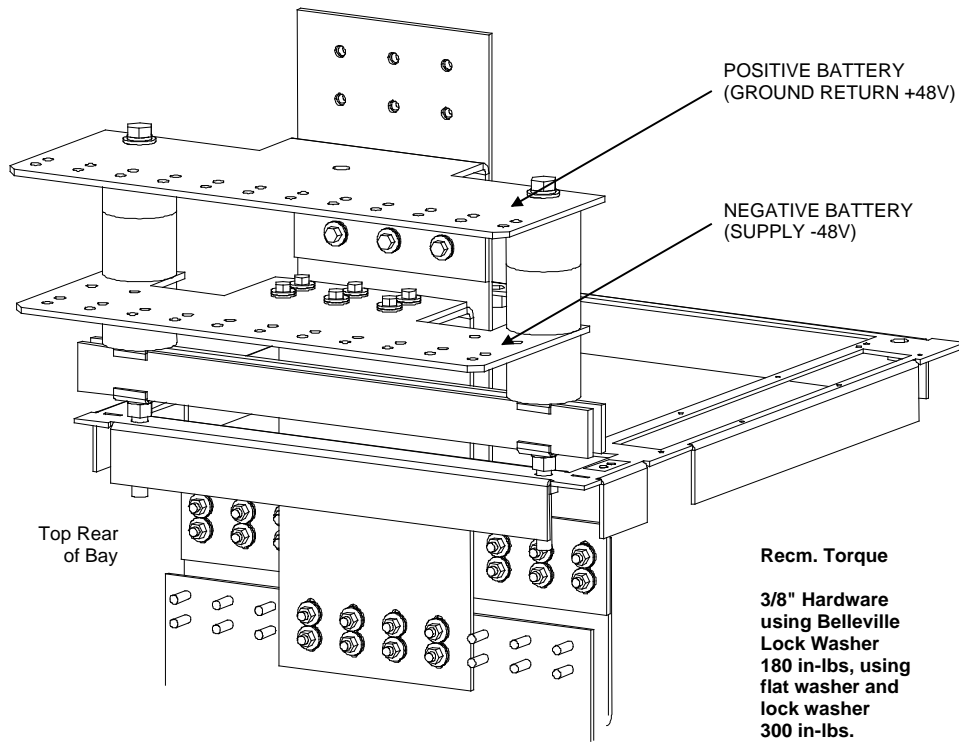
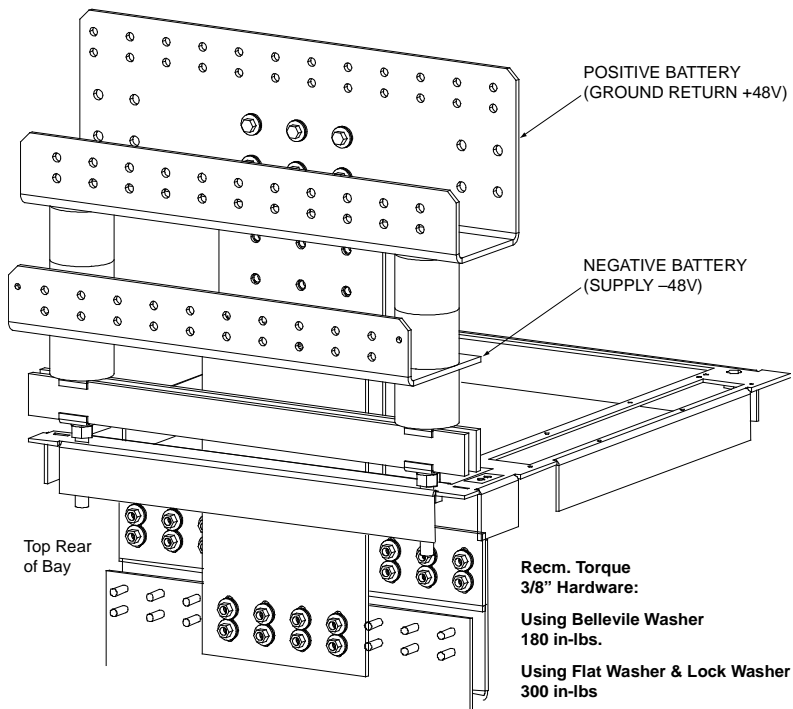


Figure 8.31 Battery Connection to Optional Vertical Battery Termination Assembly on Power/Distribution Bays

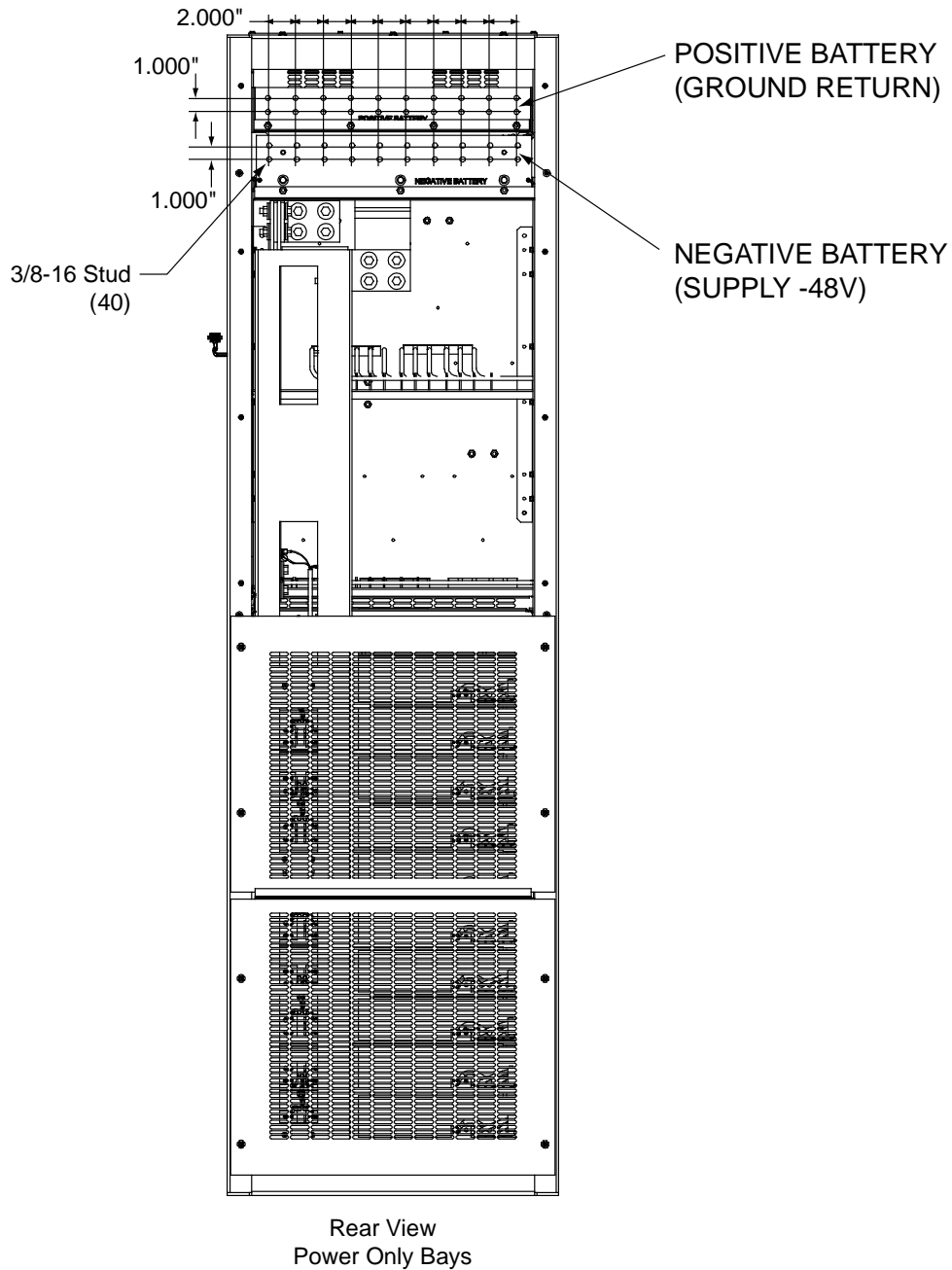


Power Only Bay

Located on the rear top of each bay are studs (3/8-16 on 1" centers). Attach battery leads to these using customer supplied two-hole lugs and mounting hardware. When lugs are secured using 3/8 inch bolts; recommended torque is 180 in-lbs when a Belleville lock washer is used, and 300 in-lbs when a standard flat washer and lock washer are used.

Refer to **Figure 8.9** for battery landing locations.

Figure 8.32 Battery Connection to Rear of Power Only Bay



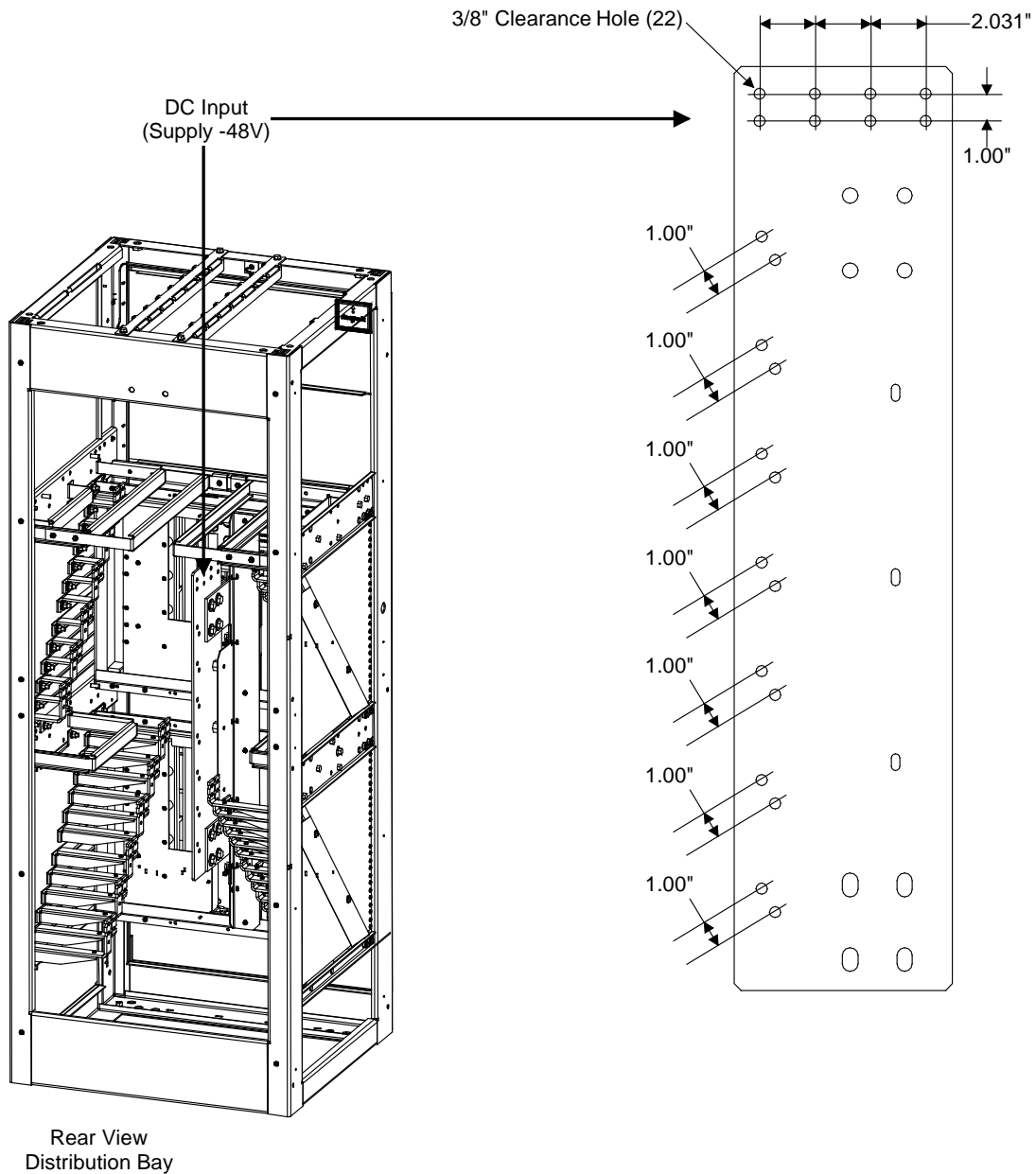
Distribution Only Bay

Located on the rear top of each bay are 3/8" clearance holes on 1" centers. Attach battery leads to these using customer supplied two-hole lugs and mounting hardware. When lugs are secured using 3/8 inch hardware; recommended torque is 180 in-lbs when a Belleville lock washer is used, and 300 in-lbs when a standard flat washer and lock washer are used.

Refer to **Figure 8.10** for battery landing locations.

The System's Positive Battery Busbar must be grounded. Refer to the National Electrical Code, applicable local codes, and your specific site requirements for grounding specifications.

Figure 8.33 Battery Connection to Rear of Distribution Only Bay



7.10 Re-Install Shields and Cover Panels

1. Replace all shields and cover panels that were removed when performing the procedures in this section. Specifically...
 - Replace front rectifier mounting position blank cover panels (Only for mounting positions NOT to be populated with rectifiers). **To do so:** Secure the cover panel with the two screws removed earlier. Use the supplied grounding washers at both locations, per cover panel.
 - Replace the three rear cover panels to each power/distribution bay and power only bay. To do so: Lower Panels: Secure the cover panels with the screws removed earlier. Use the supplied grounding washers at all locations. Top Panel: Place the keyhole slots in the cover panel over the screws in the bays, slide the cover panel down and secure by tightening the screws.
 - Replace the two rear cover panels to each distribution only bay.
 - Ensure side cover panels are installed on end bays.
 - Lists 102 and 112 only: Replace the front cover panel to each PDSC. To do so: Secure the cover panel with the eight screws removed earlier. Use the supplied grounding washers at the top left and bottom right locations.
 - Lists 102 and 112 only: Replace the rear lower cover panel to each PDSC. To do so: Secure the cover panel with the six screws removed earlier. Use the supplied grounding washers at the top left and bottom right locations.
 - Lists 102 and 112 only: Replace the rear upper cover panel to each PDSC. To do so: Place the keyhole slots in the cover panels over the screws in the PDSCs, slide the cover panels down and secure by tightening the screws. Use the supplied grounding washers at the top left and bottom right locations.
2. For bays with PDSCs, install the bay-to-bay busbar link cover shield.

8 Installing the Rectifiers

Install rectifiers from top to bottom, starting with the top most mounting position.

The rectifier weighs approximately 40 lbs.

Rectifiers can be inserted or removed with power applied (hot swappable).

Procedure

1. Remove the blank panel from the rectifier mounting position. Save this panel. The panel must be re-installed if a rectifier is removed.



NOTE! *In the next step, a safety latch is present on the left-hand (as viewed from the front) side panel of each rectifier. The latch is designed to prevent the rectifier from inadvertently being removed completely from the bay once it has been installed. It should not be necessary to depress the safety latch release when installing the rectifier.*

2. Install the rectifier into the bay by sliding it evenly into its mounting position. Secure the rectifier to the bay by tightening the captive fasteners on the rectifier.
3. Perform steps 1) and 2) for each rectifier to be installed.

9 Initially Starting, Configuring, and Checking System Operation



CAUTION! Performing various steps in the following procedures may cause a service interruption and/or result in the extension of alarms. Notify any appropriate personnel before starting these procedures. Also, notify personnel when these procedures are completed.

9.1 Initial Startup Preparation

- Ensure that rectifier mounting positions are filled by a rectifier or a blank panel as required.
- Ensure that the Operate/Standby switch on each rectifier is placed to the "Standby" position.
- Ensure that all blocks (except the last one) in the "Installation Acceptance Checklist" on page 1 have been checked.
- Ensure all distribution fuses are removed, and all distribution circuit breakers are in the off position.
- Refer to the separate NCU User manual supplied with your power system for complete controller operating information.
- Refer to the configuration drawing (C-drawing) supplied with your power system documentation for factory settings of adjustable parameters.

9.2 Initially Starting the System

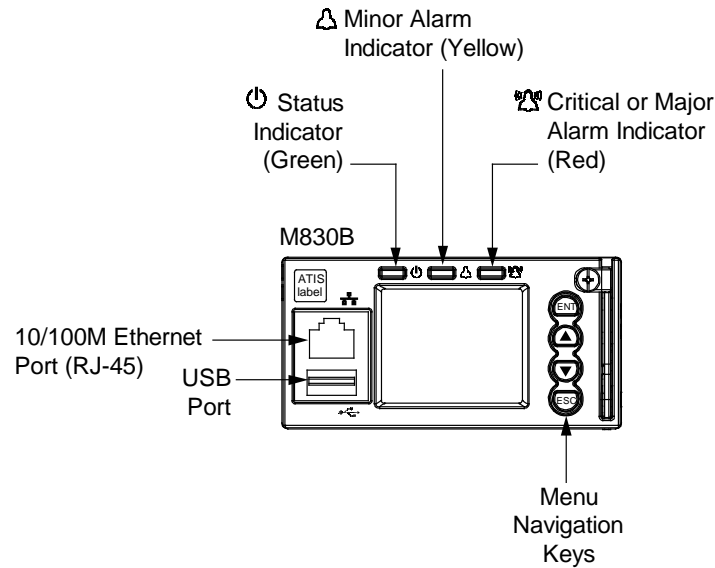
Procedure

1. Apply DC input power to the system by closing the external DC disconnect(s) or protective device(s) that supplies battery power to the system.
2. Apply AC input power to the system by closing the external AC disconnect(s) or protective device(s) that supplies power to the bay(s). There may be one or more AC disconnects or protective devices that supply power to each bay.
3. If the system is equipped with a PDSC (AC Input Power Distribution Service Cabinet), place the PDSC circuit breakers to the "on" position.
4. On each rectifier, place the Operate/Standby switch to the "operate" position.
5. Place each distribution circuit breaker (if furnished) to the ON position and install all distribution fuses.

9.3 NCU Controller Initialization

The NCU controller is located inside the primary power/distribution bay or primary power only bay. Refer to the NCU instructions (UM1M830BNA) for operational details.

Refer to **Figure 10.1** for locations of the NCU local indicators and navigation keys.

Figure 10.1 NCU Local Indicators and Navigation Keys**Procedure (NCU Local Display and Keypad)**

NOTE! The initialization routine takes several minutes. During that time various alarm indicators may illuminate on the NCU front panel and an audible alarm may sound. Disregard all alarms. An audible alarm can be silenced at any time by momentarily depressing the ENT key on the NCU controller or touching anywhere on the front panel touch screen.

1. After the NCU is powered on, the display shows the logo screen. The controller is initializing.
2. When initialization is complete, the language screen appears. Press the up or down arrow key to select the desired language. Press the ENT key to confirm the selection.
3. The Main Menu displays. See **Figure 10.2**.
4. System information is displayed in multiple screens. Press the ESC key to view other system information. Press the down arrow key to view the next screen. Press the ESC key to return to the Main Menu.
5. From the Main Menu, press the UP and DOWN keys to highlight the desired Menu graphic in the Main Menu. Press the ENT key to enter the selected menu.

NOTE! Repeatedly press the "ESC" key to return in reverse order level by level from any submenu until the Main Menu appears.

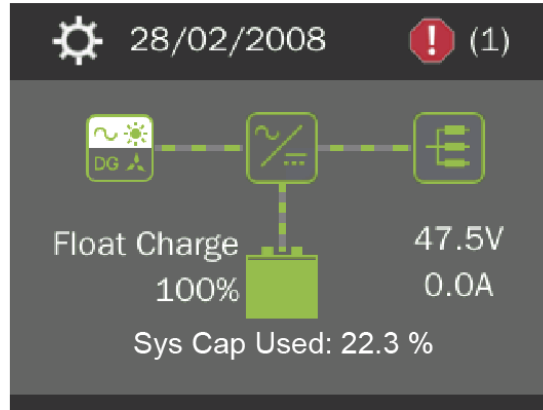
6. Refer to the following procedures to verify and set the NCU controller as required for your application.

Figure 10.2 NCU Local Display Main Menu

Main Menu

Date and time are
alternately displayed.

Green - No Alarm
Red - Alarm



The number in () indicates
the total number of alarms.

Graphics	Menu Name	Description
	Alarm (Green - No Alarm) (Red - Alarm)	View active alarms and alarm history.
	Settings	Gain access to the NCU Controller's settings menus.
	Input Power	View AC, Solar, DG, and Wind related information.
	Module	View rectifier, solar converter, and converter module related information.
	DC	View DC equipments related information.
	Battery	View battery related information.

Press the UP and DOWN keys to highlight
the desired Menu graphic in the Main Menu.

Press the ENT key to enter the selected menu.

To reboot the Controller, from the Main Menu press the ENT and ESC keys
at the same time. Release both keys. Press ENT to confirm.



NOTE! "Sys Cap Used" is based on the number of installed rectifiers.

9.4 Verifying and Setting the NCU Controller as Required for Your Application

9.4.1 General

You can verify and set the NCU controller as required for your application using the NCU local display and keypad or via the front panel touch screen. The NCU is located inside the primary power/distribution bay or primary power only bay. The front panel touch screen is located on the outside of the primary power/distribution bay or primary power only bay front door. Use the touch screen to easily access the NCU webpages. You can also use the NCU Start Wizard from the NCU local display and keypad.

Refer to the NCU instructions (UM1M830BNA) for additional information.

Note that you will have to program the NCU for any temperature probes and external inputs/outputs connected to the IB2 Interface Board, EIB Extended Interface Board, and SM-DUE.

Temperature Probes: Depending on if NCU temperature probe inputs are enabled or disabled in the NCU configuration, you may have to program the NCU for any temperature probes being used. Note that some temperature probe inputs may not be enabled by default. Refer to the C-drawing supplied with your system to determine if temperature probe inputs are enabled and pre-programmed. Refer to “Setting Temperature Sensors” in the “Common Tasks Performed via the Local Keypad and/or Web Interface” section of the NCU controller manual (UM1M830BNA) if temperature probe inputs require programming.



NOTE! When setting total rectifier current limit, the set point to each unit is the total set point divided by the number of units. For example, if the system contains five rectifiers and the current limit is set to 150 amps then each rectifier has a current limit set point of 30 amps. If one or more rectifiers are removed or fails it will take several seconds for the individual set points to the remaining rectifiers to be reset. In the example given, if one rectifier is removed the current limit set point will drop to 120 amps (30 amps times four remaining rectifiers) until the controller can send updated set points to the remaining rectifiers. This takes a couple communication cycles (several seconds) after which each rectifier would have a new set point of 37.5 amps for a total of 150 amps. The total current limit of the rectifiers should not be set such that the loss of the redundant rectifiers will cause this temporary set point to drop below the actual maximum expected load. If batteries are used on the rectifier output, the batteries should support the load until the current limit set points can be re-established due to loss of a rectifier.

9.4.2 Using the NCU Local Display and Keypad

Procedure

1. From the Main Menu (see **Figure 10.2**), press the UP and DOWN keys to highlight the desired Menu graphic in the Main Menu. Press the ENT key to enter the selected menu.



NOTE! Repeatedly press the “ESC” key to return in reverse order level by level from any submenu until the Main Menu appears.

2. Verify and set the NCU controller as required for your application.

9.4.3 Using the NCU Start Wizard from the NCU Local Display and Keypad

For initial startup, you can perform the Start Wizard from the local keypad and display to enter basic programmable parameters in one session. Refer to the “Start Wizard” section in the NCU instructions (UM1M830BNA).

9.4.4 Using the Primary Power/Distribution Bay or Primary Power Only Bay Front Panel Touch Screen to Access the NCU Webpages

The NCU controller's Ethernet port (192.168.100.100) is factory connected to a front panel touch screen. This allows local access to the NCU Webpages via the front panel touch screen.

1. Upon power up, an NCU login window appears on the touch screen. Touch in the User Name field, then enter a valid User Name. Touch in the Password field, then enter a valid Password. Then touch on LOGIN. The NCU "HOMEPAGE" window opens. Refer to the NCU controller instructions (UM1M830BNA) for webpage interface information.



NOTE! By default, the "User Name" is "admin" and the "Password" is "640275".

2. Verify and set the NCU controller as required for your application.

9.4.5 Verifying the Configuration File

Your NCU was programmed with a configuration file that sets all adjustable parameters. The version number of the configuration file can be found on the configuration drawing (C-drawing) that is supplied with your power system documentation, and on a label located on the NCU. You can verify that the correct configuration file has been loaded into your NCU by performing the following procedure.

Procedure (NCU Web Pages)

1. Using the front panel touch screen, log into the NCU webpages.
2. The NCU hardware version, software version, and configuration version are displayed on the homepage.

Procedure (NCU Local Display and Keypad)

1. With the Main Menu displayed, press ESC. A screen displays the NCU name, serial number, IP number, software version, hardware version, and configuration version number.
2. Press the DOWN key. A screen displays the NCU file system and MAC address.
3. Press ESC to return to the Main Menu.

9.4.6 Checking Basic System Settings

Navigate through the controller menus and submenus to check system settings. You can adjust any parameter as required.

Procedure (NCU Web Pages)

1. Using the front panel touch screen, log into the NCU webpages.
2. Refer to the “WEB Interface Menus” in the separate NCU manual (UM1M830BNA) supplied with your power system for navigation instructions. **Table 10.1** shows the menu navigation for some basic settings.

Procedure (NCU Local Display and Keypad)



NOTE! Repeatedly press the “ESC” key to return in reverse order level by level from any submenu until the Main Menu appears.



NOTE! Refer also to “Using the NCU Start Wizard” on page 174.

1. **To Select a Sub-Menu:**
Press the UP and DOWN keys to highlight the desired sub-menu.
Press the ENT key to enter the selected sub-menu.
2. **To Select a User:**
To select a User, use the UP and DOWN keys to move the cursor to the Select User field. Press ENT. Use the UP and DOWN keys to select a User previously programmed into the NCU. Press ENT to select the User. Note that only Users programmed into the NCU are shown. Users are programmed via the Web Interface. The default User is admin.
3. **To Enter a Password:**
If a password screen opens, a password must be entered to allow the User to make adjustments. To enter a password, use the UP and DOWN keys to move the cursor to the Enter Password field. Press ENT. Use the UP and DOWN keys to choose a character. Press ENT to accept and move to the next character. Continue this process until all characters are entered. Press ENT again to accept the password. The default password is 640275.
4. **To Change a Parameter:**
Press the UP and DOWN keys to move up and down the list of parameters. Press ENT to select the parameter. Press the UP and DOWN keys to change the parameter. Press ENT to make the change. Press ESC to cancel the change.
5. **Table 10.1** shows the menu navigation for some basic settings. Refer to the separate NCU manual (UM1M830BNA) supplied with your power system for complete Local Display menus.

Table 10.1 NCU Basic Settings Menu Navigation

Parameter	Menu Navigation
Date	<u>Local Keypad</u> : Main Menu / Settings Icon / Sys Settings / Date <u>Web Interface</u> : Settings Menu / Time Settings Tab
Time	<u>Local Keypad</u> : Main Menu / Settings Icon / Sys Settings / Time <u>Web Interface</u> : Settings Menu / Time Settings Tab
IP Communications Parameters (IP address, subnet mask address, gateway address)	<u>Local Keypad</u> : Main Menu / Settings Icon / Comm Settings / enter parameters <u>Web Interface</u> : Advance Settings Menu / Ethernet Tab / enter parameters
Float Voltage	<u>Local Keypad</u> : Main Menu / Settings Icon / Batt Settings / Charge / Float Voltage <u>Web Interface</u> : Settings Menu / Battery Tab / Float Charge Voltage
Equalize Voltage	<u>Local Keypad</u> : Main Menu / Settings Icon / Batt Settings / Charge / EQ Voltage <u>Web Interface</u> : Settings Menu / Battery Tab / Equalize Charge Voltage
Battery Capacity	<u>Local Keypad</u> : Main Menu / Settings Icon / Batt Settings / Batt1 Settings or Batt2 Settings / Rated Capacity <u>Web Interface</u> : Settings Menu / Battery Tab / Batt1 Rated Capacity and Batt2 Rated Capacity
BTRM Feature	<u>Local Keypad</u> : not available <u>Web Interface</u> : Settings Menu / Battery Tab Enter values for the following parameters: "BTRM Action" and "BTRM Voltage"
Battery Charge Temperature Compensation	<u>Local Keypad</u> : Main Menu / Settings Icon / Batt Settings / Temp Comp (enter parameters) <u>Web Interface</u> : Settings Menu / Battery Tab (enter parameters)
HVSD Limit	<u>Local Keypad</u> : not available <u>Web Interface</u> : Settings Menu / Rectifiers Tab / HVSD (set to enabled) then set HVSD Limit
Rectifier Current Limit	<u>Local Keypad</u> : Main Menu / Settings Icon / Rect Settings / Current Limit (set to enabled) then set Curr Limit Pt <u>Web Interface</u> : Settings Menu / Rectifiers Tab / Current Limit (set to enabled) then set Current Limit Point
Over Voltage Alarm 1	<u>Local Keypad</u> : Main Menu / Settings Icon / Other Settings / Over Voltage 1 <u>Web Interface</u> : Settings Menu / System Tab / Over Voltage 1
Over Voltage Alarm 2	<u>Local Keypad</u> : Main Menu / Settings Icon / Other Settings / Over Voltage 2 <u>Web Interface</u> : Settings Menu / System Tab / Over Voltage 2
Under Voltage Alarm 1	<u>Local Keypad</u> : Main Menu / Settings Icon / Other Settings / Under Voltage 1 <u>Web Interface</u> : Settings Menu / System Tab / Under Voltage 1
Under Voltage Alarm 2	<u>Local Keypad</u> : Main Menu / Settings Icon / Other Settings / Under Voltage 2 <u>Web Interface</u> : Settings Menu / System Tab / Under Voltage 2

9.4.7 Changing Battery Capacity Rating in the NCU

Change the battery capacity setting of the NCU to match the battery connected to the power system.



NOTE! After setting the battery capacity, the User should also reset the battery capacity (battery must be fully charged).

Refer to the NCU instructions (UM1M830BNA) for complete operational details.

Procedure (NCU Web Pages)

1. Using the front panel touch screen, log into the NCU webpages.
2. Go to Settings Menu / Battery Tab / Batt1 Rated Capacity and Batt2 Rated Capacity.



NOTE! Only reset the battery capacity when the battery is fully charged; otherwise, the battery charge status may not be accurate.

3. Go to Settings Menu / Battery Tab / Reset Battery Capacity (resets the battery capacity calculation).

Procedure (NCU Local Display and Keypad)

1. Go to Main Menu / Settings Icon / Batt Settings / Batt1 Settings or Batt2 Settings / Rated Capacity.



NOTE! Only reset the battery capacity when the battery is fully charged; otherwise, the battery charge status may not be accurate.

2. Go to Main Menu / Settings Icon / Batt Settings / Basic Settings / Reset Batt Cap (resets the battery capacity calculation).

9.4.8 Configuring the NCU Identification of Rectifiers and Assigning which Input Feed is Connected to the Rectifiers

When rectifiers are all installed prior to applying power and starting the system, the order in which the NCU identifies the rectifiers is by serial number (lowest serial number is Rect 1, next lowest is Rect 2, etc.). If you prefer the NCU to identify the rectifiers by position in the system, perform the following procedure.

Upon power up, the NCU arbitrarily assigns Feed AC1, AC2, or AC3 to each rectifier. This assignment is used to display rectifier AC input feed voltage(s). The User may reassign the feed to each rectifier per your specific installation by following the procedure below.

Procedure (NCU Web Pages)

1. Using the front panel touch screen, log into the NCU webpages.
2. See “Individual Rectifier Settings Page” in the NCU instructions (UM1M830BNA) and set the Rectifier ID and AC Feed (repeat for every rectifier).
then
Go to Settings Menu / Rectifiers Tab / “Confirm Rect ID/Feed”.

Procedure (NCU Local Display and Keypad)

1. Not available.

9.5 NCU Alarm Relay Check

To verify operation of the external alarm relays, use the NCU alarm relay test feature. Refer to the NCU instructions (UM1M830BNA) for instructions in using this feature.



NOTE! The relays may be preprogrammed for specific functions. Refer to the configuration drawing (C-drawing) supplied with your system for your system’s specific configuration.

9.6 Checking AC Fail Alarm

Procedure

1. Verify system is operating and no alarms are present.
2. Verify the NCU displays the Main Menu. If not, press ESC repeatedly to return to the Main Menu.
3. Open one of the AC input circuit breakers that supplies power to the rectifiers (if furnished), or open the external AC disconnect or protective device that supplies power to one of the rectifiers.
 - a) **Requirement:** An audible alarm sounds.
 - b) **Requirement:** Rectifier “AC” indicator goes out and the rectifier “FAIL” indicator goes red.

- c) **Requirement:** NCU “Critical/Major” alarm indicator goes from off to red.
- d) **Requirement:** NCU displays “Rect AC Fail” alarm.

To see the specific alarm(s), navigate to the Alarm Menu and press **ENT**. The Active Alarm screen lists two critical alarms. “**Power System CAN Comm Fail Critical**” is displayed. Scroll down by pressing the down arrow key. “**Rect Mains Failure Critical**” is displayed.

- e) **Requirement:** External alarms activate (if configured). Refer to the NCU configuration drawing (C-drawing) furnished with your system.
4. Return external AC disconnect, protective device, or internal AC input circuit breaker to the ON position.
- a) **Requirement:** Rectifier “AC” indicator goes green.
 - b) **Requirement:** Rectifier “FAIL” indicator goes out.
 - c) **Requirement:** NCU “Critical/Major” alarm indicator goes from red to off.
 - d) **Requirement:** Press ESC repeatedly to return to the Main screen. NCU displays “No Alarm”.
 - e) **Requirement:** External alarms reset (if configured).

9.7 Checking Rectifier Alarm

Procedure

1. Verify system is operating and no alarms are present.
2. Verify the NCU displays the Main Menu. If not, press ESC repeatedly to return to the Main Menu.
3. Place the Operate/Standby switch on a rectifier installed in the system to the "standby" position.
 - a) **Requirement:** An audible alarm sounds.
 - b) **Requirement:** Rectifier “AC” indicator goes out.
 - c) **Requirement:** Rectifier “FAIL” indicator goes red.
 - d) **Requirement:** NCU “Critical/Major” alarm indicator goes from off to red.
 - e) **Requirement:** NCU displays “Alarm”.

To see the specific alarm(s), navigate to the Alarm Menu and press **ENT**. The “Active Alarm” screen lists one major alarm. “**Rect (###) Comm Fail Major**” is displayed.

- f) **Requirement:** External alarms activate (if configured). Refer to the NCU configuration drawing (C-drawing) furnished with your system.
4. Place the Operate/Standby switch on another rectifier installed in the system to the "standby" position.
- a) **Requirement:** An audible alarm sounds.
 - b) **Requirement:** Rectifier “AC” indicator goes out
 - c) **Requirement:** Rectifier “FAIL” indicator goes red.

- d) **Requirement:** NCU “Critical/Major” alarm indicator stays red.
- e) **Requirement:** Press ESC repeatedly to return to the Main screen. NCU displays “Alarm”.

To see the specific alarm(s), navigate to the Alarm Menu and press **ENT**. The Active Alarm screen lists one critical and two major alarms. “**Rect Group Multi-Rect Fail Critical**” is displayed. Use arrow keys to scroll through the list of alarms. “**Rect ### Comm Fail Major**” is displayed for each removed rectifier.

- f) **Requirement:** External alarms activate (if configured). Refer to the NCU configuration drawing (C-drawing) furnished with your system.
5. Return both Operate/Standby switches to the I "operate" position.
 - a) **Requirement:** Rectifier “AC” indicators on both rectifiers goes green.
 - b) **Requirement:** Rectifier “FAIL” indicators on both rectifiers go out.
 - c) **Requirement:** NCU “Critical/Major” alarm indicator goes from red to off.
 - d) **Requirement:** Press ESC repeatedly to return to the Main screen. NCU displays “No Alarm”.
 - e) **Requirement:** External alarms reset (if configured).

9.8 Checking System Over Voltage Alarm 1 and Over Voltage Alarm 2

1. Verify system is operating and no alarms are present.
2. Verify the NCU displays the Main Menu. If not, press ESC repeatedly to return to the Main Menu.
3. Record the system voltage displayed on the NCU Main screen.
4. Navigate to the Settings Menu.
5. With the Settings menu screen displayed, navigate to “Over Voltage 1”. Main Menu / Settings Icon / Other Settings / Over Voltage 1. Record the displayed voltage setpoint.
6. Press the Enter (ENT) key; then use the UP or DOWN keys to adjust the “Over Voltage 1” value to below the system voltage recorded in step 3. Press ENT.
 - a) **Requirement:** An audible alarm sounds.
 - b) **Requirement:** NCU “Critical/Major” alarm indicator goes from off to red.
 - c) **Requirement:** Press ESC repeatedly to return to the Main Menu. NCU displays “Alarm”.

To see the specific alarm(s), navigate to the Alarm Menu and press **ENT**. The Active Alarm screen lists one critical alarm. “**Power System Over Voltage 1 Critical**” is displayed.

- d) **Requirement:** External alarms activate (if configured). Refer to the NCU configuration drawing (C-drawing) furnished with your system.
7. Without readjusting the “Over Voltage 1” setpoint, navigate to “**Over Voltage 2**”. Main Menu / Settings Icon / Other Settings / Over Voltage 2. Record the displayed voltage setpoint.

8. Press the Enter (ENT) key; then use the UP or DOWN keys to adjust the “Over Voltage 2” value to below the system voltage recorded in step 3. Press ENT.

- a) **Requirement:** An audible alarm sounds.
- b) **Requirement:** NCU “Critical/Major” alarm indicator stays red.
- c) **Requirement:** Press ESC repeatedly to return to the Main Menu. NCU displays “Alarm”.

To see the specific alarm(s), navigate to the Alarm Menu and press **ENT**. The Active Alarm screen lists two critical alarms. “**Power System Over Voltage 2 Critical**” is displayed. Use arrow keys to scroll through the list of alarms. “**Power System Over Voltage 1 Critical**” is displayed.

- d) **Requirement:** External alarms activate (if configured). Refer to the NCU configuration drawing (C-drawing) furnished with your system.
9. Navigate to “**Over Voltage 2**”. Main Menu / Settings Icon / Other Settings / Over Voltage 2.
 10. Press ENT; then use the UP or DOWN keys to adjust the “Over Voltage 2” setting to the value recorded in step 7. Press ENT.



NOTE! Over Voltage 2 alarm will retire.

11. Use the UP or DOWN keys to scroll up to “**Over Voltage 1**”.
12. Press ENT; then use the UP or DOWN keys to adjust the “Over Voltage 1” setting to the value recorded in step 5. Press ENT.
 - a) **Requirement:** NCU “Critical/Major” alarm indicator goes from red to off.
 - b) **Requirement:** Press ESC repeatedly to return to the Main screen. NCU displays “No Alarm”.
 - c) **Requirement:** External alarms reset (if configured).

9.9 Checking System Under Voltage Alarm 1 and Under Voltage Alarm 2

1. Verify system is operating and no alarms are present.
2. Verify the NCU displays the Main Menu. If not, press ESC repeatedly to return to the Main Menu.
3. Record the system voltage displayed on the NCU Main screen.
4. Navigate to the Settings Menu.
5. With the Settings Menu screen displayed, navigate to “**Under Voltage 1**”. Main Menu / Settings Icon / Other Settings / Under Voltage 1. Record the displayed voltage setpoint
6. Press the Enter (ENT) key; then use the UP or DOWN keys to adjust the “Under Voltage 1” value to above the system voltage recorded in step 3. Press ENT.
 - a) **Requirement:** An audible alarm sounds.
 - b) **Requirement:** NCU “Critical/Major” alarm indicator goes from off to red.
 - c) **Requirement:** Press ESC repeatedly to return to the Main screen. NCU displays “Alarm”.

To see the specific alarm(s), navigate to the Alarm Menu and press **ENT**. The Active Alarm screen lists one critical alarm. “**Power System Under Voltage 1 Critical**” is displayed.

- d) **Requirement:** External alarms activate (if configured). Refer to the NCU configuration drawing (C-drawing) furnished with your system.
7. Without readjusting the “Under Voltage 1” setpoint, navigate to “**Under Voltage 2**”. Main Menu / Settings Icon / Other Settings / Under Voltage 2. Record the displayed voltage setpoint.
 8. Press the Enter (ENT) key; then use the UP or DOWN keys to adjust the “Under Voltage 2” value to above the system voltage recorded in step 3. Press ENT.
 - a) **Requirement:** An audible alarm sounds.
 - b) **Requirement:** NCU “Critical/Major” alarm indicator stays red.
 - c) **Requirement:** Press ESC repeatedly to return to the Main screen. NCU displays “Alarm”.

To see the specific alarm(s), navigate to the Alarm Menu and press **ENT**. The Active Alarm screen lists two critical alarms. “**Power System Under Voltage 2 Critical**” is displayed. Use arrow keys to scroll through the list of alarms. “**Power System Under Voltage 1 Critical**” is displayed.

- d) **Requirement:** External alarms activate (if configured). Refer to the NCU configuration drawing (C-drawing) furnished with your system.
9. Navigate to “**Under Voltage 2**”.
 10. Press ENT; then use the UP or DOWN keys to adjust the “Under Voltage 2” setting to the value recorded in step 7. Press ENT.



NOTE! Low Voltage 2 alarm will retire.

11. Use the UP or DOWN keys to scroll up to “**Under Voltage 1**”.
12. Press ENT; then use the UP or DOWN keys to adjust the “Under Voltage 1” setting to the value recorded in step 5. Press ENT.
 - a) **Requirement:** NCU “Critical/Major” alarm indicator goes from red to off.
 - b) **Requirement:** Press ESC repeatedly to return to the Main screen. NCU displays “**No Alarm**”.
 - c) **Requirement:** External alarms reset (if configured).

9.10 Checking Circuit Breaker/Fuse Alarm

1. Ensure that all circuit breakers are in the ON position.
2. Verify system is operating and no alarms are present.
3. Verify the NCU displays the Main Menu. If not, press ESC repeatedly to return to the Main Menu.
4. Remove an alarm-type fuse from a distribution fuse module, and replace with a known open fuse.
 - a) **Requirement:** An audible alarm sounds.

- b) **Requirement:** The bay's "Bay Alarm" indicator goes red.
- c) **Requirement:** The distribution panel's "CBA/FA" indicator goes red.
- d) **Requirement:** NCU "Critical/Major" alarm indicator goes from off to red.
- e) **Requirement:** NCU displays "**Alarm**".

To see the specific alarm(s), navigate to the Alarm Menu and press **ENT**. The Active Alarm screen lists one critical alarm. "**Power System Load Fuse Brkr Critical**" is displayed.

- f) **Requirement:** External alarms activate (if configured). Refer to the NCU configuration drawing (C-drawing) furnished with your system.
5. Replace the open fuse with a known good fuse.
- a) **Requirement:** The bay's "Bay Alarm" indicator goes out.
 - b) **Requirement:** The distribution panel's "CBA/FA" indicator goes out.
 - c) **Requirement:** NCU "Critical/Major" alarm indicator goes from red to off.
 - d) **Requirement:** Press ESC repeatedly to return to the Main screen. NCU displays "**No Alarm**".
 - e) **Requirement:** External alarms reset (if configured).
6. Perform steps 4) and 5) for each remaining distribution fuse module located in the system.



NOTE! *The following procedure is to be used only with circuit breakers that provide an alarm indication when manually placed to the OFF (open) position. Electrical trip alarm circuit breakers cannot be easily tested in the field.*

7. Place a distribution circuit breaker to the OFF position.
- a) **Requirement:** An audible alarm sounds.
 - b) **Requirement:** The bay's "Bay Alarm" indicator goes red.
 - c) **Requirement:** The distribution panel's "CBA/FA" indicator goes red.
 - d) **Requirement:** NCU "Critical/Major" alarm indicator goes from off to red.
 - e) **Requirement:** NCU displays "**Alarm**".

To see the specific alarm(s), navigate to the Alarm Menu and press **ENT**. The Active Alarm screen lists one critical alarm. "**Power System Load Fuse Brkr Critical**" is displayed.

- f) **Requirement:** External alarms activate (if configured). Refer to the NCU configuration drawing (C-drawing) furnished with your system.
8. Place the circuit breaker back to the ON position.
- a) **Requirement:** The bay's "Bay Alarm" indicator goes out.
 - b) **Requirement:** The distribution panel's "CBA/FA" indicator goes out.
 - c) **Requirement:** NCU "Critical/Major" alarm indicator goes from red to off.
 - d) **Requirement:** Press ESC repeatedly to return to the Main screen. NCU displays "**No Alarm**".







- e) **Requirement:** External alarms reset (if configured).
9. Perform steps 7) and 8) for each remaining distribution fuse module located in the system.

9.11 Checking System Status

Procedure

1. Observe the status of the indicators located on the bay, controller, and rectifiers. If the system is operating normally, the status of these is as shown in **Table 10.2**.

Table 10.2 Status and Alarm Indicators

Component	Indicator	Indicator	Normal State
NCU		Status (Green)	On
		Minor Alarm (Yellow)	Off
		Critical or Major Alarm (Red)	Off
Rectifiers		AC/Identify (Green)	On
		Protection Alarm (480V input rectifier only) (Yellow)	Off
		Fail Alarm (Red)	Off
Bays	Bay Alarm indicator (located on outside of door at top)		On (Green)

9.12 Final Steps

Procedure

1. If any controller configuration settings were changed, refer to the NCU instructions (UM1M830BNA) and save a copy of the configuration file. This file can be used to restore the controller settings, if required, at a later date.



NOTE! Provided on a USB drive furnished with the system is a controller configuration drawing (C-drawing) and the controller configuration files loaded into the controller as shipped.

2. Verify all rectifiers and the controller are fully seated and secured.
3. Verify there are no external alarms and the local indicators are as shown in **Table 10.2**.

Connect with Vertiv on Social Media



<https://www.facebook.com/vertiv/>



<https://www.instagram.com/vertiv/>



<https://www.linkedin.com/company/vertiv/>



<https://www.x.com/vertiv/>



Vertiv.com | Vertiv Headquarters, 505 N Cleveland Ave, Westerville, OH 43082, USA

© 2026 Vertiv Group Corp. All rights reserved. Vertiv™ and the Vertiv logo are trademarks or registered trademarks of Vertiv Group Corp. All other names and logos referred to are trade names, trademarks or registered trademarks of their respective owners. While every precaution has been taken to ensure accuracy and completeness here, Vertiv Group Corp. assumes no responsibility, and disclaims all liability, for damages resulting from use of this information or for any errors or omissions.