

SYSTEM OVERVIEW

Description: +24 VDC @ up to 2000 Amperes Power System

The Vertiv™ NetSure™ 710NPBA DC Power System is an integrated power system containing rectifiers, optional converters, intelligent control, metering, monitoring, and distribution.

This power system is designed to power a load while charging a negative grounded battery. This power system is capable of operating in a batteryless installation or off battery for maintenance purposes. The power system is designed for operation with the negative output grounded.

This system consists of the following components.

- **Distribution Cabinet**

The system always includes a minimum of one distribution cabinet, which provides DC distribution through fuses and/or circuit breakers. The distribution cabinet is factory mounted in the relay rack specified when ordered.

Four different sizes of distribution cabinets are available to accept from one (1) to four (4) distribution panels. A variety of distribution panels are available that provide load distribution, battery distribution, and dual voltage load distribution for use with -48 VDC converters. These distribution panels are configured to accept either bullet nose type circuit breakers and TPS/TLS fuseholders, TPH fuses, TPL-B fuses, or GJ/218 circuit breakers. A bulk output panel is also available.

The distribution cabinet may be equipped with low voltage load disconnect (LVLD), low voltage battery disconnect (LVBD), and manual battery disconnect.

- **Controller**

The controller controls the operation of the rectifier and converter modules. The controller also provides power system control, metering, monitoring, and alarm functions.

NCU (NetSure™ Control Unit) Controller: The controller provides power system control (including optional low voltage battery disconnect (LVBD) and low voltage load disconnect (LVLD) control), rectifier control (including a charge control function), converter control, metering functions, monitoring functions, and local/remote alarm functions. The controller also supports rectifier temperature compensation if the system is equipped with a temperature probe(s). Temperature probe(s) may also be designated to monitor ambient temperature and/or battery temperature. The controller also provides data acquisition, system alarm management, and advanced battery and energy management. The controller contains a color LCD display and keypad for local access. The controller provides an Ethernet port and comes with comprehensive webpages for remote access. The controller has SNMP v3 capability for remote system management. The controller supports software upgrade via its USB port. Refer to the NCU Controller Instructions (UM1M830BNA) for more information.

ACU+ (Advanced Control Unit Plus) Controller: The controller provides power system control (including optional low voltage battery disconnect (LVBD) and low voltage load disconnect (LVLD) control), rectifier control (including a charge control function), converter control, metering functions, monitoring functions, and local/remote alarm functions. The controller also supports rectifier temperature compensation if the system is equipped with a temperature probe(s). Temperature probe(s) may also be designated to monitor ambient temperature and/or battery temperature. The controller also provides data acquisition, system alarm management, and advanced battery and energy management. The controller contains an LCD display and keypad for local access. The controller provides an Ethernet port and comes with comprehensive webpages for remote access. The controller has SNMP capability for remote system management. The controller supports software upgrade via its USB port. Refer to the ACU+ Controller Instructions (UM1M820BNA) for more information.

- **Module Mounting Assembly**

The system contains one module mounting assembly which houses rectifier modules and optional DC-DC converter modules. A module mounting assembly consists of one (1) to four (4) 8-position module mounting shelves. Refer to Power Data Sheet PD588705200 (PD588705201, PD588705202, PD588705203, PD588705204) for more information.

Vertiv™ NetSure™ 710NPBA DC Power System

System Application Guide

- **Rectifier Modules**

The system contains rectifier modules, which provide load power, battery float current, and battery recharge current during normal operating conditions. Refer to the Rectifier User Instructions (UM1R243000) for more information.

- **Optional DC-DC Converter Modules**

Where -48 VDC load power is also required, DC-DC converter modules are available. Refer to the Converter User Instructions (UM1C24481500) for more information.

General Specifications

See detailed specifications starting on page 111.

Family:	Vertiv™ NetSure™
Spec. No.:	581127000
Model:	710NPBA
Rectifier Input Voltage	Nominal 208 VAC / 240 VAC, single phase, 50 Hz / 60 Hz, with an operating range of 180 VAC to 264 VAC. Acceptable input frequency range is 47 Hz to 65 Hz.
Rectifier Output Voltage:	+24 VDC
Converter Output Voltage:	-48 VDC
Output Capacity:	
System:	2000 A, maximum
Bay:	2000 A, maximum
Distribution Panel:	600 A, maximum
1R242500 Rectifier Rating:	See UM1R243000.
1R243000 Rectifier Rating:	See UM1R243000.
1C24481500 Converter Rating:	See UM1C24481500.
Agency Approval:	UL 1801 Listed (“c UL”), NEBS
Framework Type:	Relay Rack
Mounting Width:	23 Inches, nominal
Mounting Depth:	
Distribution Cabinet:	20.09 Inches
Module Mounting Assembly:	20.00 Inches (Factory Installed Module Mounting Assemblies) 22.00 Inches (Field Expansion Module Mounting Assembly)
Access:	Front for Installation and Maintenance, Front for Operation
Supplemental Bay(s) Available:	None
Control:	Microprocessor
Color:	Bay and Module Faceplates: Textured Gray Module Mounting Assembly and Module Bodies: Bright Zinc Plating
Environment:	-40 °C to +40 °C (-40 °F to +104 °F)

TABLE OF CONTENTS

SYSTEM OVERVIEW.....1

MAIN COMPONENTS ILLUSTRATIONS7

 5811270007

LIST DESCRIPTIONS8

 List Numbers8

 List 1: Bay Common Equipment (Power and Distribution)8

 List 21: One-Row Distribution Cabinet9

 List 22: Two-Row Distribution Cabinet.....9

 List 23: Three-Row Distribution Cabinet.....10

 List 24: Four-Row Distribution Cabinet.....10

 List 29: Top Shield for Distribution Cabinet.....11

 List 30: Module Mounting Assembly Interface Components11

 List 31: Field Expansion Kit (One 8-Position Module Mounting Assembly).....12

 List 40: Individual Rectifier Feed Front Access AC Termination Assembly12

 List 41: Dual Rectifier Feed Front Access AC Termination Assembly12

 List 60: DC-DC Converter Interface Component Kit.....13

 List 90: Optional Battery Shunt, 800 A.....13

 List 91: Optional Battery Shunt, 2000 A13

 List 92: Optional Battery Shunt, 2500 A13

 List 93: Optional Battery Tray, Pre-Cabled.....14

 Batteries.....15

 Optional Battery Tray Battery Disconnect Circuit Breaker and Housing Kits.....16

 Optional Battery Tray Front Battery Cover Kits17

 List A1: Inverter, 120VAC 1KVA Hardwired Output, with AC Wireway17

 List A2: Inverter, 120 VAC 1 KVA Receptacle Output.....17

 List D2: DC-DC Converter, +24 VDC to -24 VDC18

 List D3: DC-DC Converter, +24 VDC to +12 VDC.....18

 Single Voltage Distribution Panels19

 List AA: +24 V Distribution Panel (with Return Busbar) and List AB: +24 V Distribution Panel (without Return Busbar), (24) Bullet/TPS/TLS Circuit Breaker/Fuse Positions.....19

 List AC: +24 V Distribution Panel (with Return Busbar) and List AD: +24 V Distribution Panel (without Return Busbar), (4) GJ/218 Circuit Breaker Positions.....20

 List AE: +24 V Distribution Panel, (2) TPH Fuse Positions (without Shunts) (without Return Busbar).....21

 List AF: +24 V Distribution Panel, (2) TPH Fuse Positions (with Shunts) (without Return Busbar).....22

 List AG: +24 V Distribution Panel, (4) TPH Fuse Positions (without Shunts) (without Return Busbar)23

 List AH: +24 V Distribution Panel, (4) TPH Fuse Positions (with Shunts) (without Return Busbar)24

 List AJ: +24 V Distribution Panel, (4) TPL-B Fuse Positions (without Shunts) (without Return Busbar).....25

 List AK: +24 V Distribution Panel, (4) TPL-B Fuse Positions (with Shunts) (without Return Busbar).....26

 List AL: +24 V Distribution Panel (with Return Busbar) and List AN: +24 V Distribution Panel (without Return Busbar) (26) Bullet/TPS/TLS Circuit Breaker/Fuse Positions27

 List AM: +24 V Distribution Panel (with Return Busbar) and List AP: +24 V Distribution Panel (without Return Busbar) (12) GJ/218 Circuit Breaker Positions.....29

 Dual Voltage Distribution Panels31

 List DA: +24 V / -48 V Distribution Panel, (17) +24 V Bullet/TPS/TLS Circuit Breaker/Fuse Positions (with Return Busbar) and (4) -48 V Bullet/TPS/TLS Circuit Breaker/Fuse Positions (with Return Busbar).....31

 List DB: +24 V / -48 V Distribution Panel, (13) +24 V Bullet/TPS/TLS Circuit Breaker/Fuse Positions (with Return Busbar) and (8) -48 V Bullet/TPS/TLS Circuit Breaker/Fuse Positions (with Return Busbar).....32

 List DC: +24 V / -48 V Distribution Panel, (9) +24 V Bullet/TPS/TLS Circuit Breaker/Fuse Positions (with Return Busbar) and (12) -48 V Bullet/TPS/TLS Circuit Breaker/Fuse Positions (with Return Busbar).....33

 List DD: +24 V / -48 V Distribution Panel, (5) +24 V Bullet/TPS/TLS Circuit Breaker/Fuse Positions (with Return Busbar) and (16) -48 V Bullet/TPS/TLS Circuit Breaker/Fuse Positions (with Return Busbar)34

 List DE: +24 V / -48 V Distribution Panel, (22) +24 V Bullet/TPS/TLS Circuit Breaker/Fuse Positions (with Return Busbar) and (4) -48 V Bullet/TPS/TLS Circuit Breaker/Fuse Positions (with Return Busbar).....35

 List DF: +24 V / -48 V Distribution Panel, (18) +24 V Bullet/TPS/TLS Circuit Breaker/Fuse Positions (with Return Busbar) and (8) -48 V Bullet/TPS/TLS Circuit Breaker/Fuse Positions (with Return Busbar)36

 List DG: +24 V / -48 V Distribution Panel, (14) +24 V Bullet/TPS/TLS Circuit Breaker/Fuse Positions (with Return Busbar) and (12) -48 V Bullet/TPS/TLS Circuit Breaker/Fuse Positions (with Return Busbar).....37

Vertiv™ NetSure™ 710NPBA DC Power System

System Application Guide

List DH: +24 V / -48 V Distribution Panel, (10) +24 V Bullet/TPS/TLS Circuit Breaker/Fuse Positions (with Return Busbar) and (16) -48 V Bullet/TPS/TLS Circuit Breaker/Fuse Positions (with Return Busbar)	38
List DJ: +24 V / -48 V Distribution Panel, (6) +24 V Bullet/TPS/TLS Circuit Breaker/Fuse Positions (with Return Busbar) and (20) -48 V Bullet/TPS/TLS Circuit Breaker/Fuse Positions (with Return Busbar)	39
List DK: +24 V / -48 V Distribution Panel, (26) -48 V Bullet/TPS/TLS Circuit Breaker/Fuse Positions (with Return Busbar).....	40
Battery Disconnect Distribution Panels.....	41
List BA: Battery Disconnect Distribution Panel (with Return Busbar) and List BB: Battery Disconnect Distribution Panel (without Return Busbar), (24) Bullet/TPS/TLS Circuit Breaker/Fuse Battery Disconnect Positions	41
List BC: Battery Disconnect Distribution Panel (with Return Busbar) and List BD: Battery Disconnect Distribution Panel (without Return Busbar), (4) GJ/218 Circuit Breaker Battery Disconnect Positions.....	42
List BE: Battery Disconnect Distribution Panel, (2) TPH Fuse Battery Disconnect Position (without Shunts) (without Return Busbar)	43
List BF: Battery Disconnect Distribution Panel, (2) TPH Fuse Battery Disconnect Positions (with Shunts) (without Return Busbar).....	44
List BG: Battery Disconnect Distribution Panel, (4) TPH Fuse Battery Disconnect Positions (without Shunts) (without Return Busbar)	45
List BH: Battery Disconnect Distribution Panel, (4) TPH Fuse Battery Disconnect Positions (with Shunts) (without Return Busbar)	46
Return Bar Panel.....	47
List GA: Return Bar Panel	47
Bulk Output Panel.....	48
List EA: Bulk Output Panel	48
Battery Disconnect Contactors	50
List CA: 600 A Battery Disconnect Contactor	50
List CB: 1200 A Battery Disconnect Contactor	50
List CC: 2000 A Battery Disconnect Contactor	50
Low Voltage Disconnect Options.....	51
List LB: Low Voltage Battery Disconnect (LVBD)	51
List LL: Low Voltage Load Disconnect (LVLD).....	51
Manual Battery Disconnect Option.....	51
List MB: Manual Battery Disconnect	51
ACCESSORY DESCRIPTIONS.....	52
Controller.....	52
NCU (NetSure™ Control Unit) Controller, P/N 1M830DNA	52
ACU+ (Advanced Control Unit Plus) Controller, P/N 1M820DNA	53
NCU Controller 2nd Ethernet Port Kits.....	53
NCU Controller 2nd Ethernet Port Add-On Kit, P/N 559252	53
NCU Controller 2nd Ethernet Port Retrofit Kit, P/N 559251.....	53
Optional EIB (Controller Extended Interface Board), P/N 548120	54
Optional SM-DU+ Shunt Monitoring, P/N 548078	54
In-Line Fuse and Resistor Pigtail Kits	55
1 A In-Line Fuse Pigtail Kit, P/N 431300200.....	55
1 A In-Line Fuse Pigtail Kit, P/N 431300300.....	55
1 A In-Line Fuse Pigtail Kit, P/N 535135.....	55
49.9 Ohm In-Line Resistor Pigtail Kit, P/N 424227900	55
49.9 Ohm In-Line Resistor Pigtail Kit, P/N 424228000.....	55
49.9 Ohm In-Line Resistor Pigtail Kit, P/N 424228100.....	55
Optional Temperature Probes	56
Optional SM-Temp Temperature Concentrator, P/N 547490	57
SM-Temp Jumpers, P/N 552888.....	57
Rectifier Module, P/N 1R243000	57
Rectifier Module, P/N 1R242500	58
DC-DC Converter Module, P/N 1C24481500	58
Module Mounting Position Blank Cover Panel, P/N 540959.....	58
Optional eSure™ Power Extend Converter.....	59
Relay Racks and Shipping Brackets	60
Transition Plates to Mount Relay Rack on Top of GNB Absolyte IIP Batteries.....	61
Relay Rack Isolation Kit.....	61

Vertiv™ NetSure™ 710NPBA DC Power System

System Application Guide

Crimp Lugs.....	62
Standard Crimp Lug Tables.....	62
Special Application Crimp Lug / Strap Combination Table.....	63
Lug Adapters.....	64
Busbar for 125 A, 150 A, and 200 A Bullet Nose Type Circuit Breaker, P/N 520989.....	64
Busbar for 125 A, 150 A, and 200 A Bullet Nose Type Circuit Breaker, P/N 522786.....	64
Lug Adapter Busbar Kit for 125 A, 150 A, and 200 A Bullet Nose Type Circuit Breaker, P/N 534449.....	64
Busbar for 225 A through 300 A Bullet Nose Type Circuit Breaker, P/N 514717.....	64
Lug Adapter Busbar Kit for 225 A through 300 A Bullet Nose Type Circuit Breaker, P/N 514714.....	65
Lug Adapter Busbar Kit for 3-Pole GJ/218 Circuit Breaker Installed in a List AM and List AP Distribution Panel, P/N 562888.....	65
Lug Hardware Kits.....	65
1/4-20 Hardware Kit, P/N 541084.....	65
3/8-16 Hardware Kit, P/N 548184.....	65
3/8-16 Hardware Kit, P/N 548185.....	65
Battery Busbar Extension Kit (P/N 562364).....	66
Battery Landing Busbar Kit (P/N 553584).....	66
Battery Landing Busbar Kit (P/N 555478).....	66
Distribution Devices.....	67
Bullet Nose Type Circuit Breakers and Bullet Nose Type Fuseholders e/w TPS/TLS Fuses.....	67
Optional Bullet Nose Type 6-Position GMT Distribution Fuse Block, P/N 550224, (6) GMT Fuse Positions.....	72
Optional Bullet Nose Type 6-Position GMT Distribution Fuse Block, P/N 549017, (6) GMT Fuse Positions.....	72
GMT Type Load Distribution Fuses.....	73
GJ/218 Type Circuit Breakers.....	74
TPH Type Fuses.....	75
TPL-B Type Fuses.....	76
User Replaceable Alarm, Reference, and Control Fuses.....	77
User Replaceable Components.....	77
RECOMMENDED WIRE SIZES, BRANCH CIRCUIT PROTECTION, CRIMP LUGS, AND WIRING ILLUSTRATIONS.....	78
Relay Rack Frame Grounding Requirements.....	78
AC Input Connections (if List A1 not furnished).....	78
AC Input Branch Circuit Protection and Wire Size Selection (to AC Termination Assembly).....	78
AC Input Connections to AC Termination Assembly Wiring Illustrations.....	80
AC Input, AC Output, and Frame Ground Connections when List A1 Furnished.....	88
List A1, A2 Inverter System AC Input Branch Circuit Protection and Wire Size Selection.....	88
AC Input, AC Output, and Frame Ground Connections when List A1 Furnished Wiring Illustrations.....	88
AC Input Connections to Field Installed Module Mounting Assemblies.....	90
AC Input Branch Circuit Protection and Wire Size Selection (when wiring to Expansion Rectifier Module Mounting Assembly).....	90
AC Input Connections to Expansion Rectifier Module Mounting Assembly(s) Wiring Illustrations.....	90
External Alarm, Reference, Monitoring, and Control.....	91
External Alarm, Reference, Monitoring, and Control Wire Sizes.....	91
External Alarm, Reference, Monitoring, and Control Illustrations.....	91
Load Distribution.....	99
Load Distribution Wire Sizes and Lugs Selection.....	99
Load Distribution (Distribution Panels) Illustrations.....	99
Load Distribution Wiring (Optional Bullet Nose 6-Position GMT Fuse Block) Illustration.....	100
DC Output Connections when List D2 and/or D3 DC-DC Converters Furnished.....	101
List D2, D3 Converters DC Output Connections.....	101
DC Output Connections when List D2 and/or D3 Furnished Wiring Illustration.....	101
Battery Input.....	102
Battery Input Wire Sizes and Lugs Selection.....	102
Battery Input Illustration.....	103
Wire Size and Lug Selection Tables for Load and Battery Connections to TPS/TLS Fuses and Bullet Nose Type Circuit Breakers.....	107
Wire Size and Lug Selection Tables for Load and Battery Connections to TPH Fuses, TPL-B Fuses, and GJ/218 Type Circuit Breakers or Battery Branch Circuits.....	109
SPECIFICATIONS.....	111
1. System.....	111

Vertiv™ NetSure™ 710NPBA DC Power System

System Application Guide

1.1	Output Ratings.....	111
1.2	Input Ratings.....	111
1.3	Environmental Ratings	111
1.4	Compliance Information.....	111
1.5	IB2 and EIB (Controller Interface Board) Ratings.....	112
2.	Module mounting assembly	112
3.	Rectifier	112
4.	Converter	112
5.	Controller.....	112
6.	List A1 and List A2 Inverter	112
7.	List D2 and D3 DC-DC Converter	112
MECHANICAL SPECIFICATIONS.....		113
Overall Dimensions.....		113
List 21 (One-Row Distribution Cabinet)		113
List 22 (Two-Row Distribution Cabinet)		114
List 23 (Three-Row Distribution Cabinet).....		115
List 24 (Four-Row Distribution Cabinet)		116
List 93 (Battery Tray).....		117
Dimensions (Arrangement of System Configured with Lists A1, A2, D2, D3).....		118
Weights.....		119
RELATED DOCUMENTATION.....		122
BATTERY MANUFACTURER INFORMATION.....		122

MAIN COMPONENTS ILLUSTRATIONS

581127000

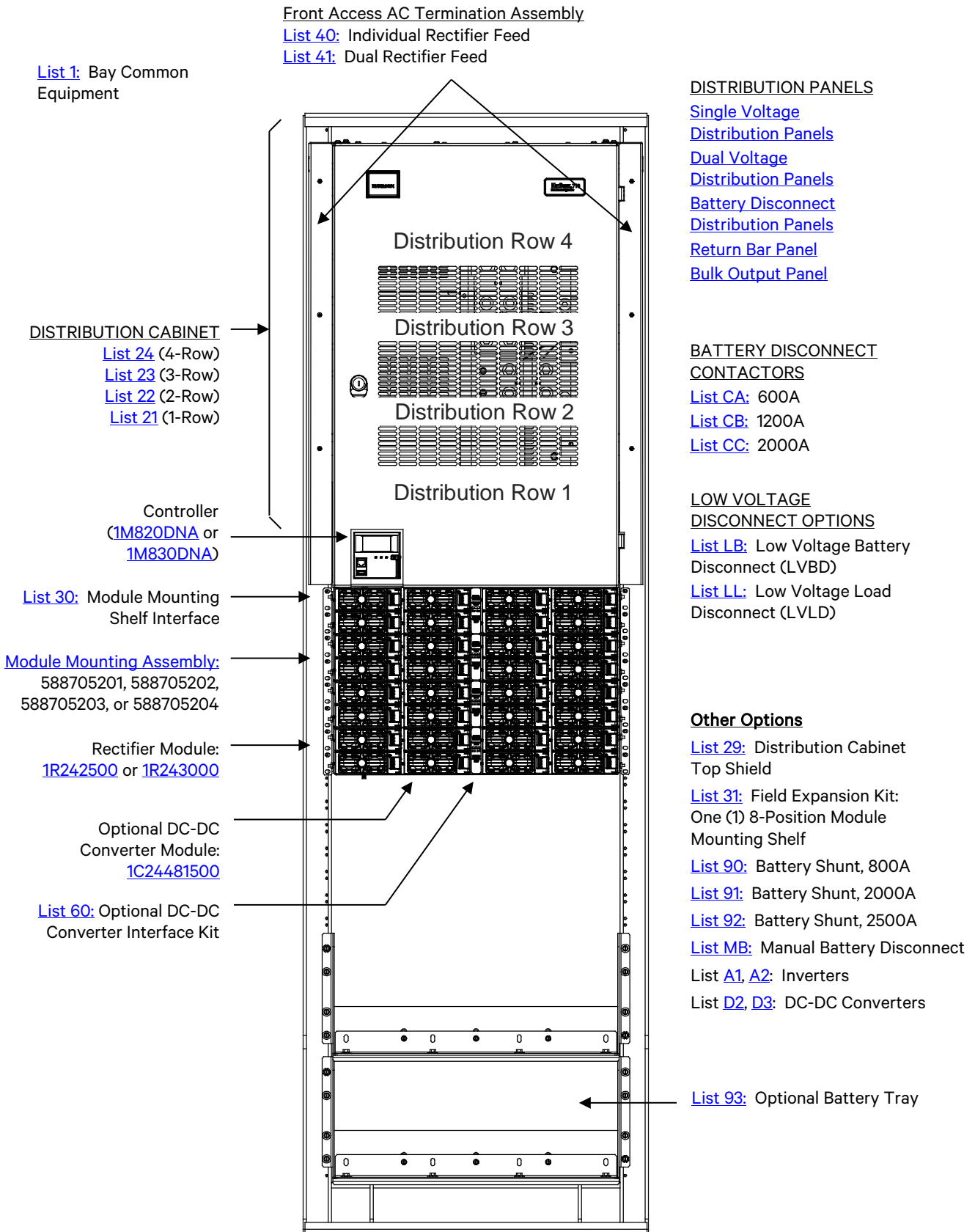

LIST DESCRIPTIONS

List Numbers

List 1: Bay Common Equipment (Power and Distribution)

Features

- ◆ Provides common equipment for one “power and distribution” bay rated for up to 2000 amperes of distribution.
- ◆ Accepts one (1) distribution cabinet (options are 1-row, 2-row, 3-row, or 4-row cabinet).
- ◆ Accepts one (1) controller.
- ◆ Includes the IB2 controller interface board.
- ◆ Accepts the EIB controller extended interface board.
- ◆ Accepts one (1) module mounting assembly. The module mounting assembly can consist of one (1), two (2), three (3), or four (4) factory interconnected 8-position module mounting shelves. Each module mounting shelf in a module mounting assembly provides eight (8) mounting positions for rectifier modules. When a module mounting shelf within the module mounting assembly is equipped with a DC-DC Converter Kit, the four (4) middle positions will accept either rectifier modules or +24 V / -48 V DC-DC converter modules.

Restrictions

When the system is equipped with a List [40](#) or [41](#) front access AC Termination Assembly, refer to the restrictions under these list descriptions.

Ordering Notes

- 1) Order a relay rack or shipping brackets per “[Relay Racks and Shipping Brackets](#)” under ACCESSORY DESCRIPTIONS. If required, order Relay Rack Transition Plates per “[Transition Plates to Mount Relay Rack on Top of GNB Absolyte IIP Batteries](#)” under ACCESSORY DESCRIPTIONS. If required, order Relay Rack Isolation Kit as applicable per “Relay Rack Isolation Kit” on page 61.
- 2) Order one (1) List [21](#), [22](#), [23](#), or [24](#) distribution cabinet.
 - a) Order up to four (4) (per the capacity of the distribution cabinet ordered) distribution panels, battery disconnect panels, return bar panel, and/or bulk output panel as required per “[Single Voltage Distribution Panel](#)”, “[Dual Voltage Distribution Panel](#)”, “[Battery Disconnect Distribution Panel](#)”, “[Return Bar Panel](#)”, and “[Bulk Output Panel](#)” under LIST DESCRIPTIONS.
 - b) Order battery disconnect contactors and low voltage disconnect options as required per “[Battery Disconnect Contactors](#)” and “[Low Voltage Disconnect Options](#)” under LIST DESCRIPTIONS.
 - c) Order one (1) ACU+ controller, P/N [1M820DNA](#) or NCU controller, P/N [1M830DNA](#).
 - d) Order the optional EIB controller extended interface board as required (see page 54).
 - e) Order fuses and/or circuit breakers as required per “[Distribution Devices](#)” under ACCESSORY DESCRIPTIONS.
 - f) Order input and load distribution lugs, lug adapters, and lug hardware kits as required.
 - g) Order a distribution cabinet top shield as required per List [29](#).
 - h) Order a battery shunt as required per List [90](#), [91](#), or [92](#).
- 3) Order one (1) List [30](#) (interface components for one (1) module mounting assembly). Order a module mounting assembly per PD588705201/PD588705202/PD588705203/PD588705204. List 30 is factory connected to the module mounting assembly ordered.
 - a) Order one (1) List [60](#) (DC-DC Converter Kit) for each 8-position module mounting shelf in which DC-DC converters are required. Note that some module mounting assemblies consist of multiple 8-position module mounting shelves. The kit permits the middle four (4) positions in an 8-position module mounting shelf to accept DC-DC converter modules or rectifier modules. List 60 is factory installed within the 8-position module mounting shelf. List 60 kits will be installed starting with bottom 8-position module mounting shelf in the module mounting assembly and working up.
 - b) Order either individual rectifier AC feed or dual rectifier AC feed per List [40](#) or [41](#).
 - c) Order rectifier modules as required, P/N [1R242500](#) or P/N [1R243000](#).
 - d) Order DC-DC converter modules as required, P/N [1C24481500](#).
 - e) Order one (1) module mounting position blank cover panel for each empty module mounting position in the system, P/N [540959](#), as desired.

Vertiv™ NetSure™ 710NPBA DC Power System

System Application Guide

- 4) Order battery trays as required per Lists [93](#).
 - a) Order batteries as required per “[Batteries](#)” under LIST DESCRIPTIONS.
 - b) Order “[Optional Battery Tray Battery Disconnect Circuit Breaker and Housing Kits](#)” as required.
 - c) Order “[Optional Battery Tray Front Battery Cover Kits](#)” as required.

List 21: One-Row Distribution Cabinet

Features

- ◆ Accepts one (1) distribution panel.
- ◆ Rated for up to 600 amperes of distribution.

Restrictions

For use in [List 1](#).

Battery disconnect panels cannot be ordered for use in a List 21.

Ordering Notes

- 1) Order one (1) distribution panel as required per “[Single Voltage Distribution Panel](#)”, “[Dual Voltage Distribution Panel](#)”, and “[Bulk Output Panel](#)” under LIST DESCRIPTIONS.
- 2) Order fuses and/or circuit breakers as required per “[Distribution Devices](#)” under ACCESSORY DESCRIPTIONS.
- 3) Order input and load distribution lugs, lug adapters, and lug hardware kits as required.
- 4) Order battery contactor, battery shunt, and low voltage disconnect options as required.

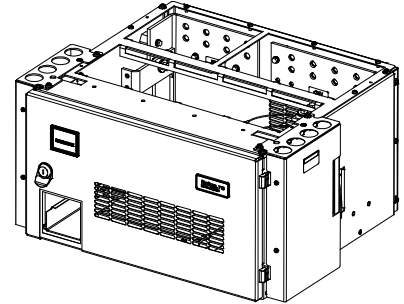

List 22: Two-Row Distribution Cabinet

Features

- ◆ Accepts up to two (2) total distribution panels, battery disconnect distribution panels, and/or return bar panel.
- ◆ Rated for up to 1200 amperes of distribution.

Restrictions

For use in [List 1](#).

The List LL Low Voltage Load Disconnect (LVLD) option cannot be installed in the field for systems that are not equipped with any LVLD's from the factory. Field replacement of factory installed LVLD contactors is still available.

Ordering Notes

- 1) Order up to two (2) distribution panels as required per “[Single Voltage Distribution Panel](#)”, “[Dual Voltage Distribution Panel](#)”, “[Battery Disconnect Distribution Panel](#)”, “[Return Bar Panel](#)”, and “[Bulk Output Panel](#)” under LIST DESCRIPTIONS.
- 2) Order fuses and/or circuit breakers as required per “[Distribution Devices](#)” under ACCESSORY DESCRIPTIONS.
- 3) Order input and load distribution lugs, lug adapters, and lug hardware kits as required.
- 4) Order battery contactor, battery shunt, and low voltage disconnect options as required.

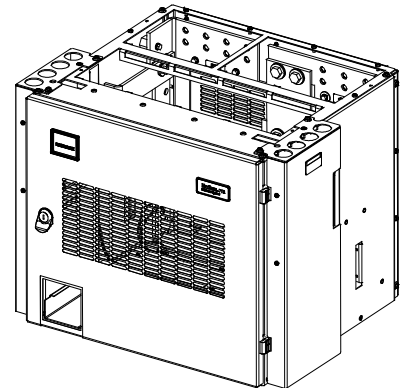

List 23: Three-Row Distribution Cabinet

Features

- ◆ Accepts up to three (3) total distribution panels, battery disconnect distribution panels, and/or return bar panel.
- ◆ Rated for up to 1800 amperes of distribution.

Restrictions

For use in [List 1](#).

The List LL Low Voltage Load Disconnect (LVLD) option cannot be installed in the field for systems that are not equipped with any LVLD's from the factory. Field replacement of factory installed LVLD contactors is still available.

Ordering Notes

- 1) Order up to three (3) distribution panels as required per “[Single Voltage Distribution Panel](#)”, “[Dual Voltage Distribution Panel](#)”, “[Battery Disconnect Distribution Panel](#)”, “[Return Bar Panel](#)”, and “[Bulk Output Panel](#)” under LIST DESCRIPTIONS.
- 2) Order fuses and/or circuit breakers as required per “[Distribution Devices](#)” under ACCESSORY DESCRIPTIONS.
- 3) Order input and load distribution lugs, lug adapters, and lug hardware kits as required.
- 4) Order battery contactor, battery shunt, and low voltage disconnect options as required.

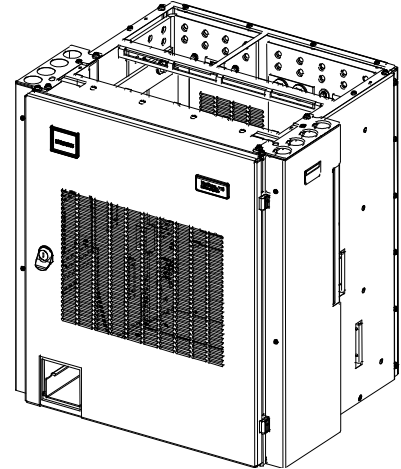

List 24: Four-Row Distribution Cabinet

Features

- ◆ Accepts up to four (4) total distribution panels, battery disconnect distribution panels, and/or return bar panel.
- ◆ Rated for up to 2000 amperes of distribution.

Restrictions

For use in [List 1](#).

The List LL Low Voltage Load Disconnect (LVLD) option cannot be installed in the field for systems that are not equipped with any LVLD's from the factory. Field replacement of factory installed LVLD contactors is still available.

Ordering Notes

- 1) Order up to four (4) distribution panels as required per “[Single Voltage Distribution Panel](#)”, “[Dual Voltage Distribution Panel](#)”, “[Battery Disconnect Distribution Panel](#)”, “[Return Bar Panel](#)”, and “[Bulk Output Panel](#)” under LIST DESCRIPTIONS.
- 2) Order fuses and/or circuit breakers as required per “[Distribution Devices](#)” under ACCESSORY DESCRIPTIONS.
- 3) Order input and load distribution lugs, lug adapters, and lug hardware kits as required.
- 4) Order battery contactor, battery shunt, and low voltage disconnect options as required.

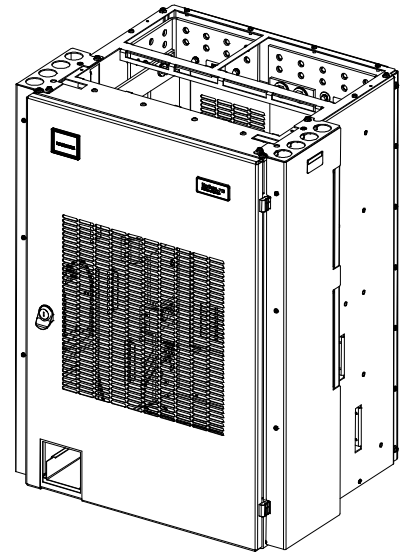

Vertiv™ NetSure™ 710NPBA DC Power System

System Application Guide

List 29: Top Shield for Distribution Cabinet

Features

- ◆ Plastic shield covers all wiring access openings in top of distribution cabinet. Individual cutouts can be removed for wiring as required for specific installation.

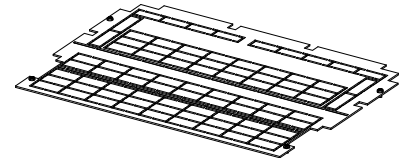

Restrictions

Cannot be used with List [A1](#).

Ordering Notes

- 1) Where closed top cover is required, order one (1) List 29 for each List [21](#), [22](#), [23](#), and [24](#) ordered.

List 30: Module Mounting Assembly Interface Components

Features

- ◆ Provides components to add one (1) module mounting assembly (Spec. No. 588705201, 588705202, 588705203, or 588705204) to List 1.
- ◆ The separately ordered module mounting assembly can consist of one (1), two (2), three (3), or four (4) factory interconnected 8-position module mounting shelves.
- ◆ Refer to Power Data Sheet PD588705200 (PD588705201, PD588705202, PD588705203, PD588705204) for module mounting assembly information.

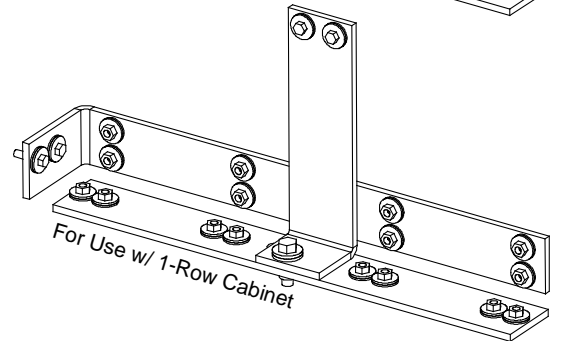
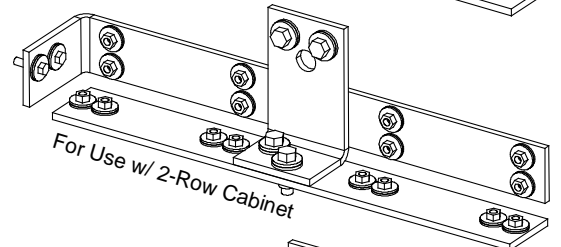
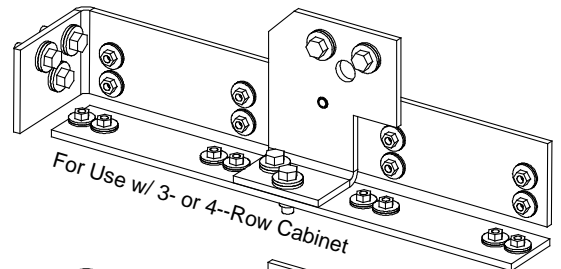

Restrictions

Factory installed only on the distribution cabinet.

Includes 'module mounting assembly-to-power system/distribution cabinet' interconnect components only. The module mounting assembly must be ordered separately.

Each bay can be equipped with a maximum of one (1) module mounting assembly.

Ordering Notes

- 1) Order one (1) List 30 per bay, regardless of the number of module mounting positions required (32 positions maximum per bay).
- 2) Order a module mounting assembly per Power Data Sheet PD588705200 (PD588705201/PD588705202/PD588705203/PD588705204) as required.
- 3) Order one (1) List [60](#) (DC-DC Converter Kit) for each 8-position module mounting shelf in which DC-DC converters are required. Note that some module mounting assemblies consist of multiple 8-position module mounting shelves. The kit permits the middle four (4) positions in an 8-position module mounting shelf to accept DC-DC converter modules or rectifier modules. List 60 is factory installed within the 8-position module mounting shelf. List 60 kits will be installed starting with bottom 8-position module mounting shelf in the module mounting assembly and working up.
- 4) Order rectifier modules as required, P/N [1R242500](#) or P/N [1R243000](#).
- 5) Order DC-DC converter modules as required, P/N [1C24481500](#).
- 6) Order one (1) module mounting position blank cover panel for each empty module mounting position in the system, P/N [540959](#), as desired.

List 31: Field Expansion Kit (One 8-Position Module Mounting Assembly)

Features

- ◆ Provides one (1) Spec No. 588705200 module mounting assembly and components required for field installation in an existing power system that has eight (8) to twenty-four (24) positions.
- ◆ Included are busbars for connecting rectifier output to the main system bus, and cables for connecting DC-DC converter output to the appropriate dual voltage bus distribution panel assembly (if using converters).
- ◆ The module mounting assembly provides eight (8) mounting positions for rectifier modules. The four (4) middle positions will accept either rectifier modules or +24 V / -48 V DC-DC converter modules.
- ◆ The expansion 8-position module mounting assembly is equipped with individual rectifier module AC input feeds at the rear (one branch circuit per module mounting position, eight feeds total).
- ◆ Refer to Power Data Sheet PD588705200 (PD588705201, PD588705202, PD588705203, PD588705204) for more information.

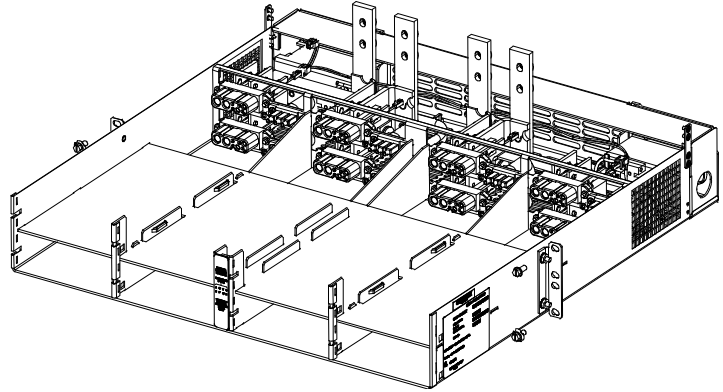

Restrictions

For field installation only.

Maximum number of List 31 that can be installed in a bay is one (1).

Original system must have a module mounting assembly (up to twenty-four [24] positions).

Cannot be used in a power bay equipped with a Spec No. 588705204 module mounting assembly.

Ordering Notes

- 1) For a bay equipped with Spec. No. 588705201 List 1, Spec. No. 588705202 List 1, or Spec. No. 588705203 List 1, order one (1) List 31.
- 2) Order rectifier modules as required, P/N [1R242500](#) or P/N [1R243000](#).
- 3) Order DC-DC converter modules as required, P/N [1C24481500](#).
- 4) Order one (1) module mounting position blank cover panel for each empty module mounting position in the system, P/N [540959](#), as desired.

List 40: Individual Rectifier Feed Front Access AC Termination Assembly

Features

- ◆ Provides “Individual Rectifier Feed” input terminations for all rectifier positions in the bay.

Restrictions

Factory installed only.

For initial installation only. Initial rectifier module shelves are factory wired to List 40. If a rectifier module field expansion shelf (List 31) is added to the system, AC inputs MUST be wired directly to the shelf.

Ordering Notes

- 1) For each List 1, order either List 40 or 41.

List 41: Dual Rectifier Feed Front Access AC Termination Assembly

Features

- ◆ Provides “Dual Rectifier Feed” (two rectifiers per AC feed) input terminations for all rectifier positions in the bay.

Restrictions

Factory installed only.

For initial installation only. Initial rectifier module shelves are factory wired to List 41. If a rectifier module field expansion shelf (List 31) is added to the system, AC inputs MUST be wired directly to the shelf.

Ordering Notes

- 1) For each List 1, order either List 40 or 41.

List 60: DC-DC Converter Interface Component Kit

Features

- ◆ Provides components to add DC-DC converter capability to one (1) 8-position module mounting shelf in a module mounting assembly. With one (1) List 60 installed, the four middle mounting positions in an 8-position module mounting shelf in the module mounting assembly will accept DC-DC converters or rectifier modules.
- ◆ Includes cables for connection of converter output to a dual voltage distribution panel.

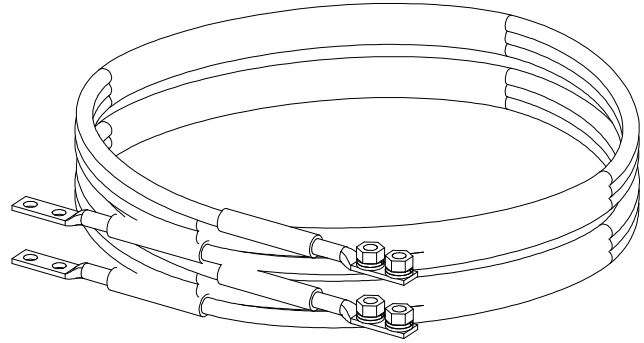

Restrictions

Total rectifier output power available for customer loads is reduced by the input power of each DC-DC converter module installed.

Ordering Notes

- 1) Order one (1) List 60 (DC-DC Converter Kit) for each 8-position module mounting shelf in which DC-DC converters are required. Note that some module mounting assemblies consist of multiple 8-position module mounting shelves. The kit permits the middle four (4) positions in an 8-position module mounting shelf to accept DC-DC converter modules or rectifier modules. List 60 is factory installed within the 8-position module mounting shelf. Multiple List 60 kits will be installed starting with bottom 8-position module mounting shelf in the module mounting assembly and working up.
- 2) Order up to four (4) DC-DC converter modules ([1C24481500](#)) for each List 60 ordered.

List 90: Optional Battery Shunt, 800 A

Features

- ◆ Provides an 800 A battery shunt.

Restrictions

For use with List 21 only.

Cannot be used with low voltage load disconnect (LVLVD) in a List 21.

Ordering Notes

- 1) Order as required.

List 91: Optional Battery Shunt, 2000 A

Features

- ◆ Provides a 2000 A battery shunt.

Restrictions

For use with Lists 22 only.

Ordering Notes

- 1) Order as required.

List 92: Optional Battery Shunt, 2500 A

Features

- ◆ Provides a 2500 A battery shunt.

Restrictions

For use with List 23 and 24 only.

Ordering Notes

- 1) Order as required.

List 93: Optional Battery Tray, Pre-Cabled

Features

- ◆ Each List 93 provides one (1) battery tray factory mounted in the 23" wide system relay rack specified when ordered. Each battery tray holds four (4) 12 V front terminal valve regulated lead acid (VRLA) batteries. Battery cabling is factory provided and connected to the system's main busbars. Batteries are configured as two (2) 24 V strings per tray.
- ◆ Battery trays can be ordered with or without battery disconnect circuit breakers. When circuit breakers are ordered, one is provided in the +24 V lead of each battery string (2 circuit breakers per tray).
- ◆ Battery tray dimensions are 21.3" wide X 22.4" deep. Refer to "[List 93 \(Battery Tray\)](#)" under *PHYSICAL SIZE INFORMATION* for a typical battery tray arrangement.
- ◆ Battery spacers included.

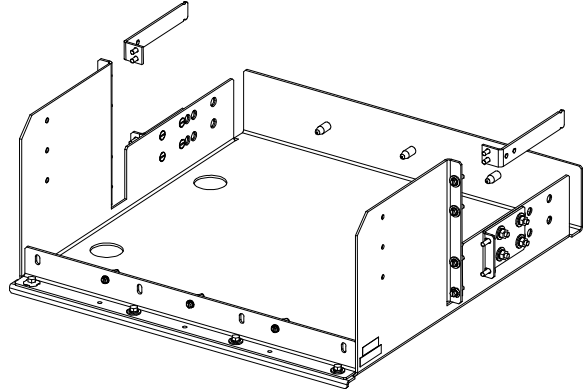

Restrictions

Designed to accommodate the batteries listed under "[Batteries](#)" in the LIST DESCRIPTIONS section.

A single battery tray must mount at bottom of relay rack. Multiple battery trays must mount starting at bottom of relay rack and working upward. Factory spaces battery trays 6RU, 7RU, or 8RU apart as determined by battery selected. If no battery selected, factory spaces battery trays 8RU apart. Spacing can be increased above that required for the battery selected up to a maximum of 8RU.

Cable size for each tray is 2 AWG for optional battery disconnect circuit breakers selected up to 100 A and 1/0 AWG for circuit breakers selected over 100 A or if circuit breakers are not selected.

Maximum number of List 93 per relay rack is four (4).

Not a stand-alone battery system. Must be used as part of a power system that includes a List 1 with a List 21, 22, 23, or 24 and a List 30.

Ordering Notes

- 1) Order up to four (4) battery trays per relay rack, as required.
- 2) Order battery cable termination kit, one per bay. P/N 553584 for use with List 21, P/N 555478 for use with Lists 22, 23 and 24.
- 3) Order batteries separately. See "[Batteries](#)" in the LIST DESCRIPTIONS section. Battery cables and lugs factory provided and connected.
- 4) If optional battery tray battery disconnect circuit breakers are desired, order per "[Optional Battery Tray Battery Disconnect Circuit Breakers and Housing Kits](#)" in the ACCESSORY DESCRIPTIONS section.
- 5) If optional battery tray front battery cover is desired, order per "[Optional Battery Tray Front Battery Cover Kits](#)" in the LIST DESCRIPTIONS section.

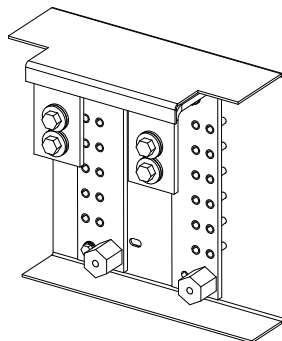

P/N 553584

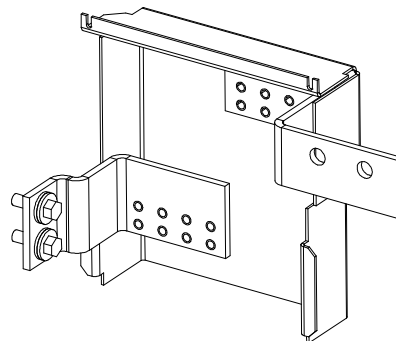

P/N 555478

Vertiv™ NetSure™ 710NPBA DC Power System

System Application Guide

Batteries

Restrictions

For use in List 93 battery trays.

Ordering Notes

- 1) Order batteries from Table 1, as required.

Manufacturer*	Manufacturer P/N	P/N (12 V Module)	Capacity (A-Hr)	Dimension W x L x H (Inches) (per 12 V Module)	Min Tray Spacing (RU)	Weight (lb) (per 12V Module)	Lug Kit 2 AWG	Lug Kit 1/0 AWG
C&D	TEL12-160F	140456	157	5.0 x 22.0 x 11.10	7	116.8	528236	528237
C&D	TEL12-180F	--	181	5.0 x 22.0 x 12.60	8	132.3	528236	528237
C&D	TEL12-210F	554579	202	5.0 x 22.0 x 12.60	8	132.3	528236	528237
Deka	12AVR-150ET	122018	150	4.90 x 22.00 x 11.75	8	115	528234	528235
Deka	12AVR-170ET	541381	170	4.90 x 22.0 x 12.60	8	120	528234	528235
Deka	HT170ET	--	164	4.93 x 22.17 x 12.58	8	118	528234	528235
Enersys	12V155FS	122010	155	4.90 x 22.10 x 11.10	7	106.9	528234	528235
Enersys	12V170FS	--	170	4.90 x 22.10 x 11.10	7	112	528234	528235
Enersys	SBS 170F	--	170	4.92 x 22.10 x 11.10	7	116	528234	528235
Enersys	SBS 190F	--	190	4.90 x 22.10 x 12.40	8	132	528234	528235
FIAMM	12FAT100	--	100	4.96 x 21.97 x 9.06	6	95	528234	528235
FIAMM	12FAT155	--	155	4.96 x 21.97 x 12.64	8	129	528234	528235
FIAMM	12FAT180	--	100	4.96 x 21.97 x 12.64	8	134	528234	528235
Northstar	NSB155FT RED	--	155	4.90 x 22.0 x 11.00	7	101	528234	528235
Northstar	NSB170FT RED	126111	170	4.90 x 22.00 x 12.60	8	116	528234	528235
Northstar	NSB190FT RED	--	190	4.90 x 22.00 x 12.60	8	123	528234	528235
Northstar	NSB155FT HT	--	154	4.90 x 22.00 x 11.0	7	117	528234	528235
Northstar	NSB170FT HT	--	174	4.90 x 22.00 x 12.60	8	121	528234	528235
Northstar	NSB190FT HT	--	190	4.90 x 22.00 x 12.60	8	132	528234	528235
GS Yuasa	PYL12V160FT	--	160	4.90 x 21.90 x 11.0	7	116.2	528234	528235
GS Yuasa	PYL12V185FT	--	185	4.90 x 21.90 x 12.50	8	133.8	528234	528235

* See [Battery Manufacturer Information](#)

Table 1
Batteries and Battery Lug Kits

Optional Battery Tray Battery Disconnect Circuit Breaker and Housing Kits

Features

- ◆ Provides a battery disconnect circuit breaker housing factory mounted on the left and right sides of the List 93 battery tray. Selected circuit breakers factory installed and wired.

Restrictions

For use in List 93 battery trays.

Factory wires battery trays with 2 AWG cables for battery disconnect circuit breakers selected up to 150 A and 1/0 AWG cables for circuit breakers selected over 150 A.

Ordering Notes

- 1) For each battery tray, order two (2) circuit breakers from Table 2.

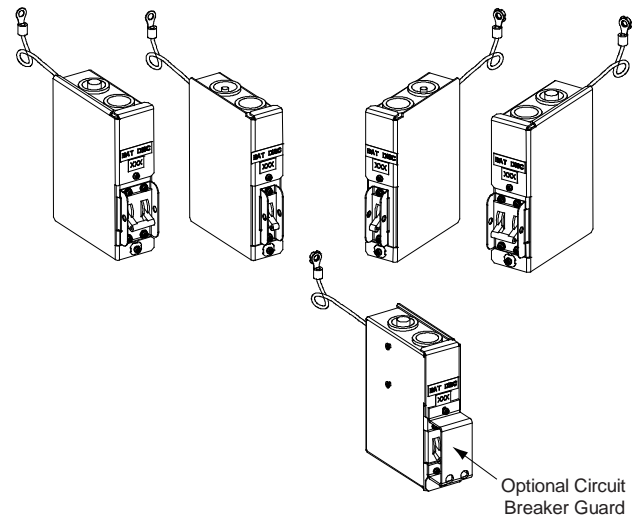

Ampere Rating	P/N Electrical/Mechanical Trip ¹ (Black Handle)	No. of Poles
50	256694300	1-Pole
60	256694700	
70	256695100	
75	256695500	
100	256695900	
125	100762	2-Pole
150	100763	
200	121810	

Circuit Breaker Alarm Operation:

¹Provides an alarm during an electrical or manual trip condition.

Table 2
Battery Tray Battery Disconnect Circuit Breakers

- 2) For each double-pole circuit breaker ordered, order an optional circuit breaker guard P/N 548014, if desired, to block front access to circuit breaker handle.
- 3) For each battery tray ordered, order two (2) battery circuit breaker housing kits (one right side mounted and one left side mounted) from Table 3.

Part Number	Description
528500	Single Pole, Right Side Mounted
528501	Single Pole, Left Side Mounted
528502	Double Pole, Right Side Mounted
528503	Double Pole, Left Side Mounted

Table 3
Battery Tray Battery Disconnect Circuit Breaker Housing Kits

Vertiv™ NetSure™ 710NPBA DC Power System

System Application Guide

Optional Battery Tray Front Battery Cover Kits

Features

- ◆ Provides a front battery cover to the List 93 battery tray.

Restrictions

For use in List 93 battery trays.

Ordering Notes

- 1) Order one (1) kit per tray from the following table, as required.

Part Number	Height
548020	8U
548021	7U
548022	6U

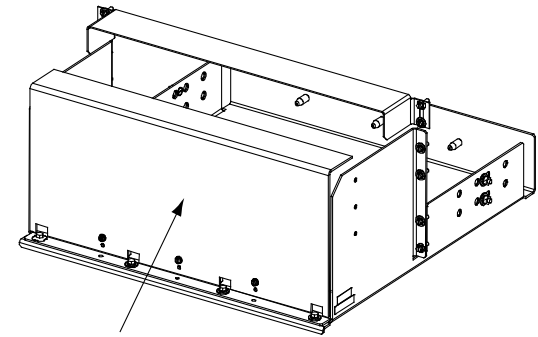

List A1: Inverter, 120VAC 1KVA Hardwired Output, with AC Wireway

Features

- ◆ Inverter operates from +24 VDC System bus to provide 120 VAC, 60 Hz, 1 KVA, single-phase output.
- ◆ Includes AC wireway on left-hand side of system, with AC termination panel at top. Provides AC input terminals for one (1) PCU Mounting Shelf (individual feed), AC input terminals for List A1 and A2 Inverters, and AC output terminals for List A1 Inverter. Wireway accepts four (4) 3/4" conduit fittings.
- ◆ Includes alarm wiring to the system controller.
- ◆ Includes 70 A circuit breaker and DC input jumpers.
- ◆ See [Dimensions and Arrangement of System Configured with Lists A1, A2, D2, D3](#) for equipment arrangement.
- ◆ For more inverter information, refer to the separate Inverter manual.

Restrictions

Maximum of one (1) List A1 per power system.

List A1 is available only with a 4-row ([List 24](#)) Distribution Cabinet and an 8-position PCU mounting shelf.

List [29](#) is not available with List A1.

Ordering Notes

- 1) List A1 Includes a 5U high mounting panel for up to two inverters. List A2, if ordered, mounts in this panel.

List A2: Inverter, 120 VAC 1 KVA Receptacle Output

Features

- ◆ Operates from +24 VDC System bus to provide 120 VAC, 60 Hz, 1 kVA single-phase output.
- ◆ Mounts in panel provided with List A1.
- ◆ Provides socket receptacle on rear of inverter for output connections.
- ◆ Includes alarm wiring to system controller.
- ◆ Includes 70 A circuit breaker and DC input jumpers.
- ◆ For more inverter information, refer to the separate Inverter manual.

Restrictions

Maximum of one (1) List A2 per power system.

Must be used in conjunction with [List A1](#).

Ordering Notes

- 1) List A1 includes a 5U high mounting panel for up to two inverters. List A2 mounts in this panel.

Vertiv™ NetSure™ 710NPBA DC Power System

System Application Guide

List D2: DC-DC Converter, +24 VDC to -24 VDC

Features

- ◆ Operates from +24 VDC System bus to provide -24 VDC @ 6.25 A (150 W maximum, continuous).
- ◆ Mounts on a 3U mounting panel that can accommodate two converters.
- ◆ Provides screw-type terminal blocks on converter for output connections.
- ◆ Includes alarm wiring to system controller.
- ◆ Includes 15 A circuit breaker and DC input jumpers.
- ◆ For more converter information, refer to the separate DC-DC Converter manual.

Ordering Notes

- 1) Up to two converters can be ordered, in any combination of List D2 or [D3](#). When one List D2 or [D3](#) is ordered, a mounting panel for up to two converters is provided. If a second List D2 or D3 is ordered, it is mounted in the same panel as the first List D2 or D3.

Restrictions

Maximum of two (2) List D2 and/or [D3](#) per power system.

List D3: DC-DC Converter, +24 VDC to +12 VDC

Features

- ◆ Operates from +24 VDC System bus to provide +12 VDC @ 8 A (100 W maximum, continuous).
- ◆ Mounts on a 3U mounting panel that can accommodate two converters.
- ◆ Provides screw-type terminal blocks on converter for output connections.
- ◆ Includes alarm wiring to system controller.
- ◆ Includes 10 A circuit breaker and DC input jumpers.
- ◆ For more converter information, refer to the separate DC-DC Converter manual.

Restrictions

Maximum of two (2) List [D2](#) and/or D3 per power system.

Ordering Notes

- 1) Up to two converters can be ordered, in any combination of List D2 or [D3](#). When one List D2 or [D3](#) is ordered, a mounting panel for up to two converters is provided. If a second List D2 or D3 is ordered, it is mounted in the same panel as the first List D2 or D3.

Single Voltage Distribution Panels

List AA: +24 V Distribution Panel (with Return Busbar) and

List AB: +24 V Distribution Panel (without Return Busbar),

(24) Bullet/TPS/TLS Circuit Breaker/Fuse Positions

Features

- ◆ (24) +24 V Load Distribution Fuse / Circuit Breaker Mounting Positions:
3 A to 100 A TPS/TLS Type Fuses,
1 A to 300 A Bullet Nose Type Circuit Breakers, or accepts
“[Optional Bullet Nose Type 6-Position GMT Distribution Fuse Block \(P/N 550224\)](#)”.
- ◆ List AA includes a return busbar; List AB does not include a return busbar.
- ◆ 600 A Maximum Capacity.

Restrictions

Can be installed in any row 1-4 of a 1-, 2-, 3-, or 4-row distribution cabinet.

Unless otherwise specified fuses and/or circuit breakers are mounted from left to right, starting with the highest capacity and working to the lowest capacity.

125 A, 150 A, 175 A, and 200 A circuit breakers occupy two mounting positions.

225 A, 250 A, and 300 A circuit breakers occupy three mounting positions.

Caution: *A 100 A circuit breaker or fuse SHALL HAVE an empty mounting position between it and any other overcurrent protective device. A 175 A or greater circuit breaker SHALL HAVE an empty mounting position between it and any other overcurrent protective device.*

Maximum lug width, 0.625 inches.

Ordering Notes

- 1) Specify row for panel location(s).
- 2) Order low voltage load disconnect List LL per panel as required.
- 3) List AB: To terminate load returns within the distribution cabinet, order List GA as required.
- 4) Order circuit breakers as required per Table 11 or Table 12.
- 5) Order fuses as required per Table 13. Also order one (1) P/N 117201 bullet nose type fuseholder per fuse ordered. Order replacement alarm fuses (18/100 A) per Table 18.
- 6) Order 6-position GMT fuse block P/N 550224 and fuses per Table 14 as required.
- 7) Order load lugs (two hole, 1/4” bolt clearance hole, 5/8” centers) as required for each distribution position per Table 22.
- 8) Order lug hardware kit (P/N 541084) as required. Lug hardware kit provides thirty-two (32) sets of 1/4-20 hardware (nuts, flat washers, and lock washers), enough for sixteen (16) lug landing points.

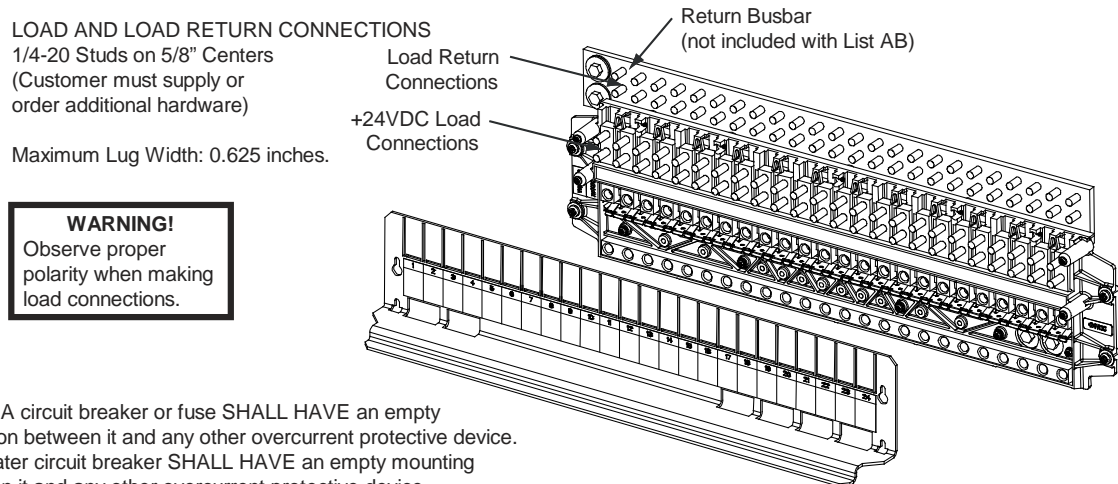

Caution: A 100 A circuit breaker or fuse SHALL HAVE an empty mounting position between it and any other overcurrent protective device.
A 175 A or greater circuit breaker SHALL HAVE an empty mounting position between it and any other overcurrent protective device.

Vertiv™ NetSure™ 710NPBA DC Power System

System Application Guide

List AC: +24 V Distribution Panel (with Return Busbar) and List AD: +24 V Distribution Panel (without Return Busbar), (4) GJ/218 Circuit Breaker Positions

Features

- ◆ (4) +24 V Load Distribution Circuit Breaker Mounting Positions:
100 A to 800 A GJ/218 Type Circuit Breakers.
- ◆ List AC includes a return busbar; List AD does not include a return busbar.
- ◆ 600 A Maximum Capacity.
Maximum current rating of each landing point is 360 A.

Restrictions

Can be installed in any bus row 1-4 of a 1-, 2-, 3-, or 4-row distribution cabinet.

Maximum lug width, 1.375 inches.

For an 800 A circuit breaker, continuous load must not exceed 600 A.

Ordering Notes

- 1) Specify row for panel location(s).
- 2) Order low voltage load disconnect List LL per panel as required.
- 3) List AD: To terminate load returns within the distribution cabinet, order List GA as required.
- 4) Order circuit breakers and associated jumper kits as required per Table 15.
- 5) Order load lugs (two hole, 3/8" bolt clearance hole, 1" centers) as required for each distribution position per Table 23.
- 6) Order lug hardware kit (P/N 548184) as required. Lug hardware kit provides sixteen (16) sets of 3/8-16 hardware (bolts, flat washers, and lock washers), enough for eight (8) lug landing points.

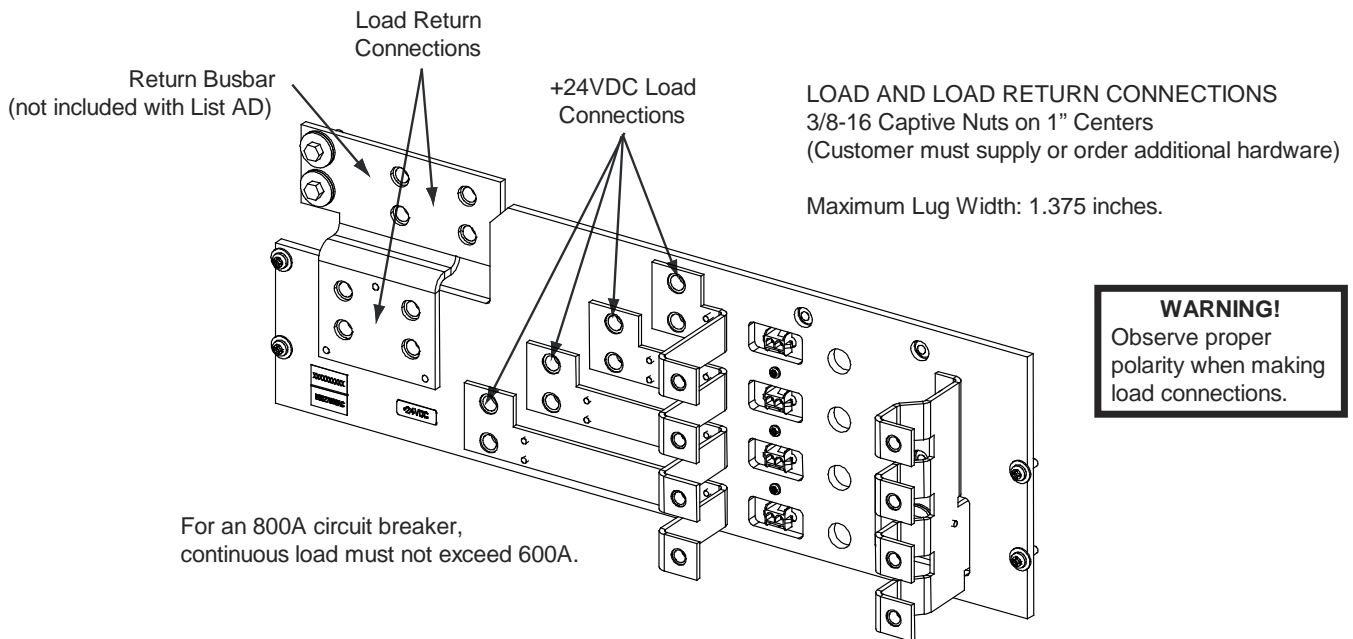

Vertiv™ NetSure™ 710NPBA DC Power System

System Application Guide

List AE: +24 V Distribution Panel,

(2) TPH Fuse Positions (without Shunts) (without Return Busbar)

Features

- ◆ (2) +24 V Distribution Fuse Mounting Positions:
70 A to 600 A TPH Type Fuses.
- ◆ Does NOT include Shunts.
- ◆ Does NOT include a return busbar.
- ◆ 600 A Maximum Capacity.

Restrictions

Can be installed in any row 1-4 of a 1-, 2-, 3-, or 4-row distribution cabinet.

Maximum lug width, 1.88 inches.

Ordering Notes

- 1) Specify row for panel location(s).
- 2) Order low voltage load disconnect List LL per panel as required.
- 3) To terminate load returns within the distribution cabinet, order List GA as required.
- 4) Order fuses as required per Table 16. Order replacement alarm fuses (1/4 A) per Table 18.
- 5) Order load lugs (two hole, 3/8" bolt clearance hole, 1" centers) as required for each distribution position per Table 23.
- 6) Order lug hardware kit (P/N 548184) as required. Lug hardware kit provides sixteen (16) sets of 3/8-16 hardware (bolts, flat washers, and lock washers), enough for eight (8) lug landing points.

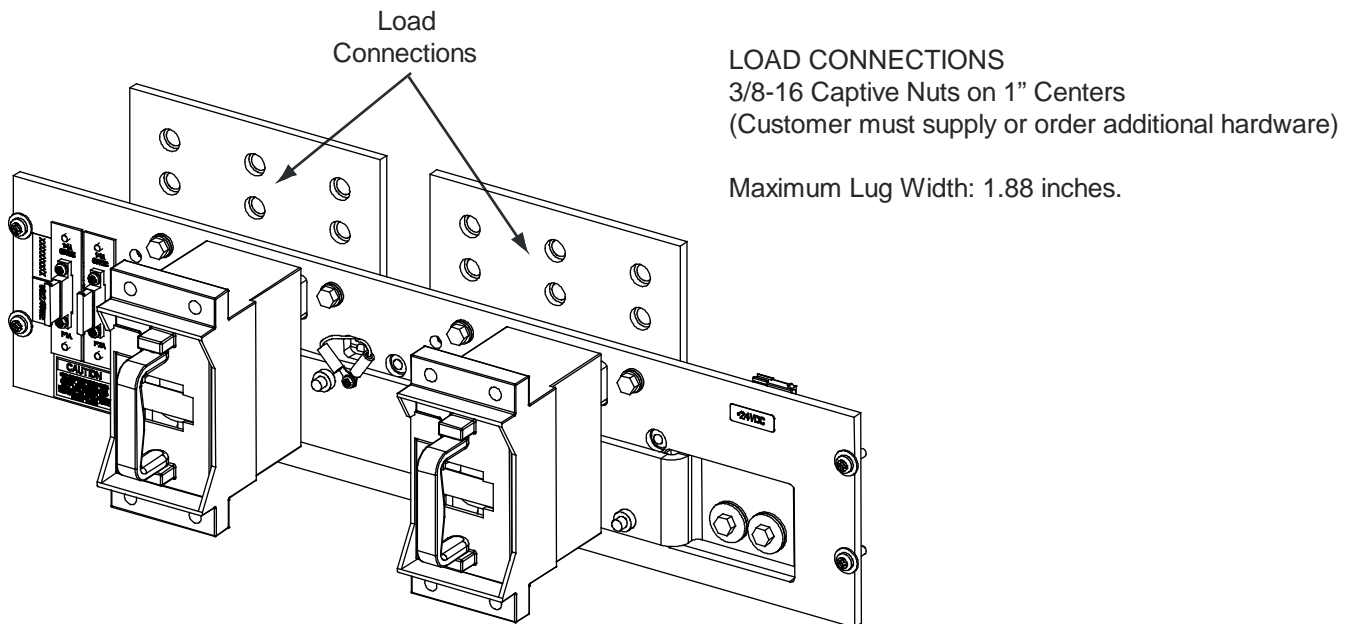

Vertiv™ NetSure™ 710NPBA DC Power System

System Application Guide

List AF: +24 V Distribution Panel,

(2) TPH Fuse Positions (with Shunts) (without Return Busbar)

Features

- ◆ (2) +24 V Distribution Fuse Mounting Positions:
70 A to 600 A TPH Type Fuses.
- ◆ Includes Shunts, 800 A / 25 mV. Each shunt is equipped with 10' jumpers for connection to monitoring device. If the system is equipped with an SM-DU+, the leads are trimmed and connected to the SM-DU+ (internal to the distribution cabinet).
- ◆ Does NOT include a return busbar.
- ◆ 600 A Maximum Capacity.

Restrictions

Can be installed in any row 1-4 of a 1-, 2-, 3-, or 4-row distribution cabinet.

Maximum lug width, 1.88 inches.

Ordering Notes

- 1) Specify row for panel location(s).
- 2) Order low voltage load disconnect List LL per panel as required.
- 3) To terminate load returns within the distribution cabinet, order List GA as required.
- 4) Order fuses as required per Table 16. Order replacement alarm fuses (1/4 A) per Table 18.
- 5) Order load lugs (two hole, 3/8" bolt clearance hole, 1" centers) as required for each distribution position per Table 23.
- 6) Order lug hardware kit (P/N 548184) as required. Lug hardware kit provides sixteen (16) sets of 3/8-16 hardware (bolts, flat washers, and lock washers), enough for eight (8) lug landing points.

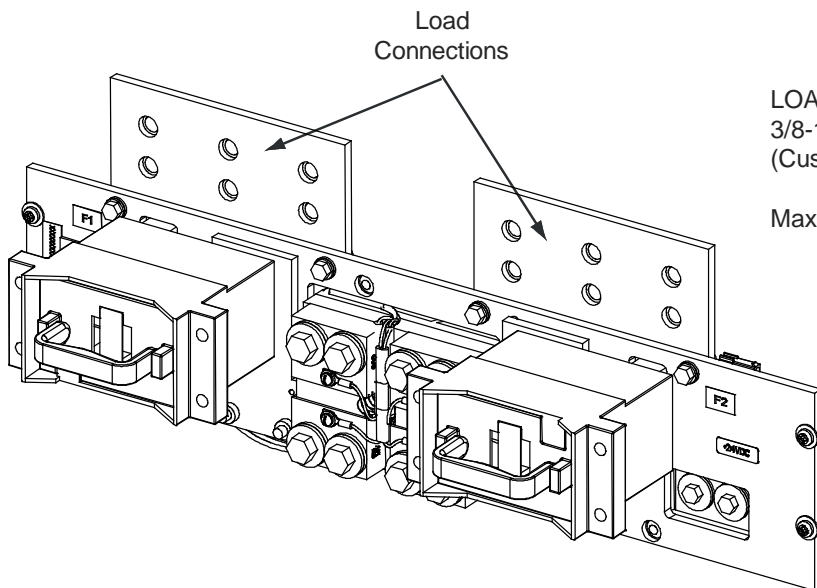

LOAD CONNECTIONS

3/8-16 Captive Nuts on 1" Centers
(Customer must supply or order additional hardware)

Maximum Lug Width: 1.88 inches.

Vertiv™ NetSure™ 710NPBA DC Power System

System Application Guide

List AG: +24 V Distribution Panel,

(4) TPH Fuse Positions (without Shunts) (without Return Busbar)

Features

- ◆ (4) +24 V Distribution Fuse Mounting Positions:
70 A to 400 A TPH Type Fuses.
- ◆ Does NOT include Shunts.
- ◆ Does NOT include a return busbar.
- ◆ 600 A Maximum Capacity.

Restrictions

Can be installed in any row 1-4 of a 1-, 2-, 3-, or 4-row distribution cabinet.

Maximum lug width, 1.75 inches.

Ordering Notes

- 1) Specify row for panel location(s).
- 2) Order low voltage load disconnect List LL per panel as required.
- 3) To terminate load returns within the distribution cabinet, order List GA as required.
- 4) Order fuses as required per Table 16. Order replacement alarm fuses (1/4 A) per Table 18.
- 5) Order load lugs (two hole, 3/8" bolt clearance hole, 1" centers) as required for each distribution position per Table 23.
- 6) Order lug hardware kit (P/N 548184) as required. Lug hardware kit provides sixteen (16) sets of 3/8-16 hardware (bolts, flat washers, and lock washers), enough for eight (8) lug landing points.

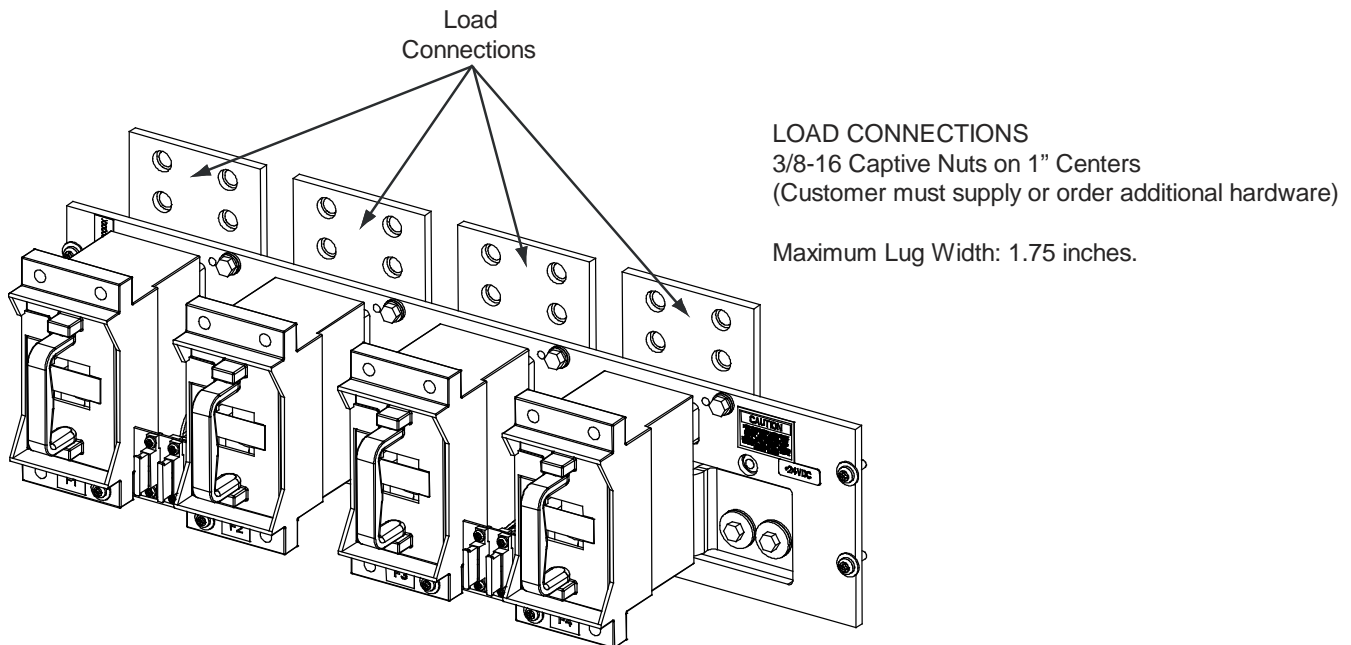

Vertiv™ NetSure™ 710NPBA DC Power System

System Application Guide

List AH: +24 V Distribution Panel,

(4) TPH Fuse Positions (with Shunts) (without Return Busbar)

Features

- ◆ (4) +24 V Distribution Fuse Mounting Positions:
70 A to 400 A TPH Type Fuses.
- ◆ Includes Shunts, 600 A / 25 mV. Each shunt is equipped with 10' jumpers for connection to monitoring device. If the system is equipped with an SM-DU+, the leads are trimmed and connected to the SM-DU+ (internal to the distribution cabinet).
- ◆ Does NOT include a return busbar.
- ◆ 600 A Maximum Capacity.

Restrictions

Can be installed in any row 1-4 of a 1-, 2-, 3-, or 4-row distribution cabinet.

Maximum lug width, 1.75 inches.

Ordering Notes

- 1) Specify row for panel location(s).
- 2) Order low voltage load disconnect List LL per panel as required.
- 3) To terminate load returns within the distribution cabinet, order List GA as required.
- 4) Order fuses as required per Table 16. Order replacement alarm fuses (1/4 A) per Table 18.
- 5) Order load lugs (two hole, 3/8" bolt clearance hole, 1" centers) as required for each distribution position per Table 23.
- 6) Order lug hardware kit (P/N 548184) as required. Lug hardware kit provides sixteen (16) sets of 3/8-16 hardware (bolts, flat washers, and lock washers), enough for eight (8) lug landing points.

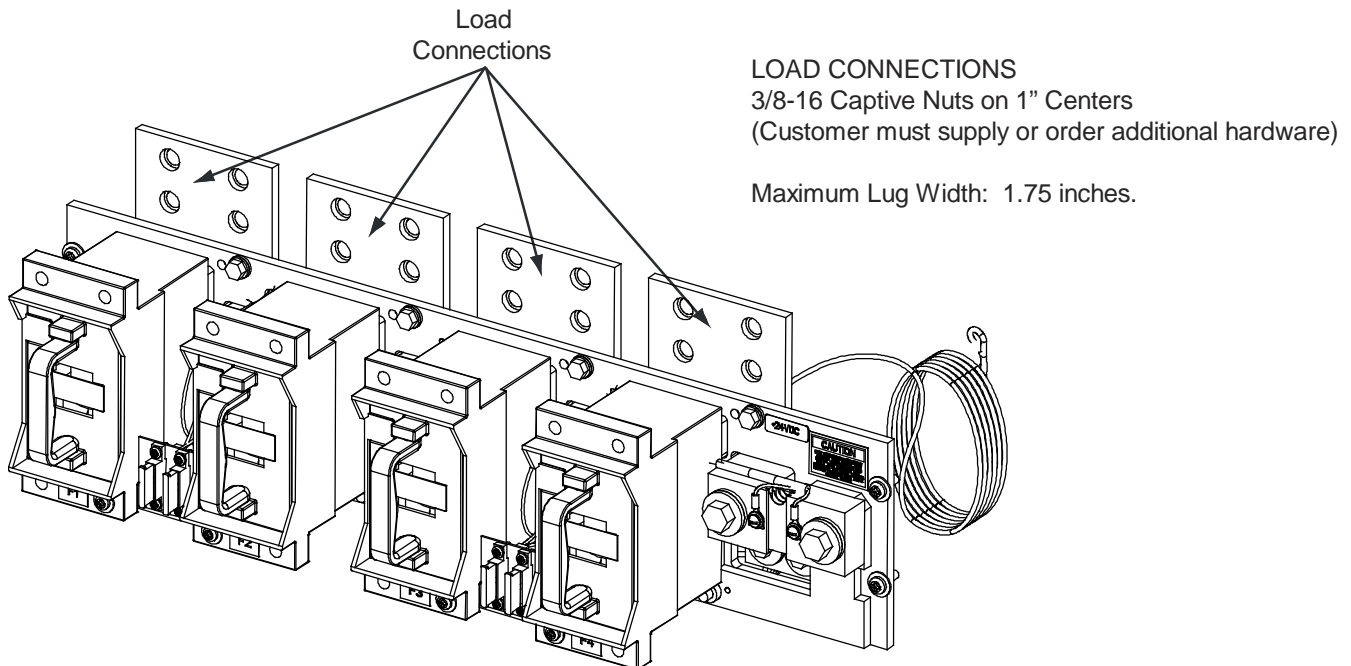

Vertiv™ NetSure™ 710NPBA DC Power System

System Application Guide

List AJ: +24 V Distribution Panel,

(4) TPL-B Fuse Positions (without Shunts) (without Return Busbar)

Features

- ◆ (4) +24 V Distribution Fuse Mounting Positions:
70 A to 250 A TPL-B Type Fuses.
- ◆ Does NOT include Shunts.
- ◆ Does NOT include a return busbar.
- ◆ 600 A Maximum Capacity.

Restrictions

Can be installed in any row 1-4 of a 1-, 2-, 3-, or 4-row distribution cabinet.

Maximum lug width, 1.50 inches.

Ordering Notes

- 1) Specify row for panel location(s).
- 2) Order low voltage load disconnect List LL per panel as required.
- 3) To terminate load returns within the distribution cabinet, order List GA as required.
- 4) Order fuses as required per Table 17. Order replacement alarm fuses (18/100 A) per Table 18.
- 5) Order load lugs (two hole, 3/8" bolt clearance hole, 1" centers) as required for each distribution position per Table 23.
- 6) Order lug hardware kit (P/N 548185) as required. Lug hardware kit provides sixteen (16) sets of 3/8-16 hardware (nuts, flat washers, and lock washers), enough for eight (8) lug landing points.

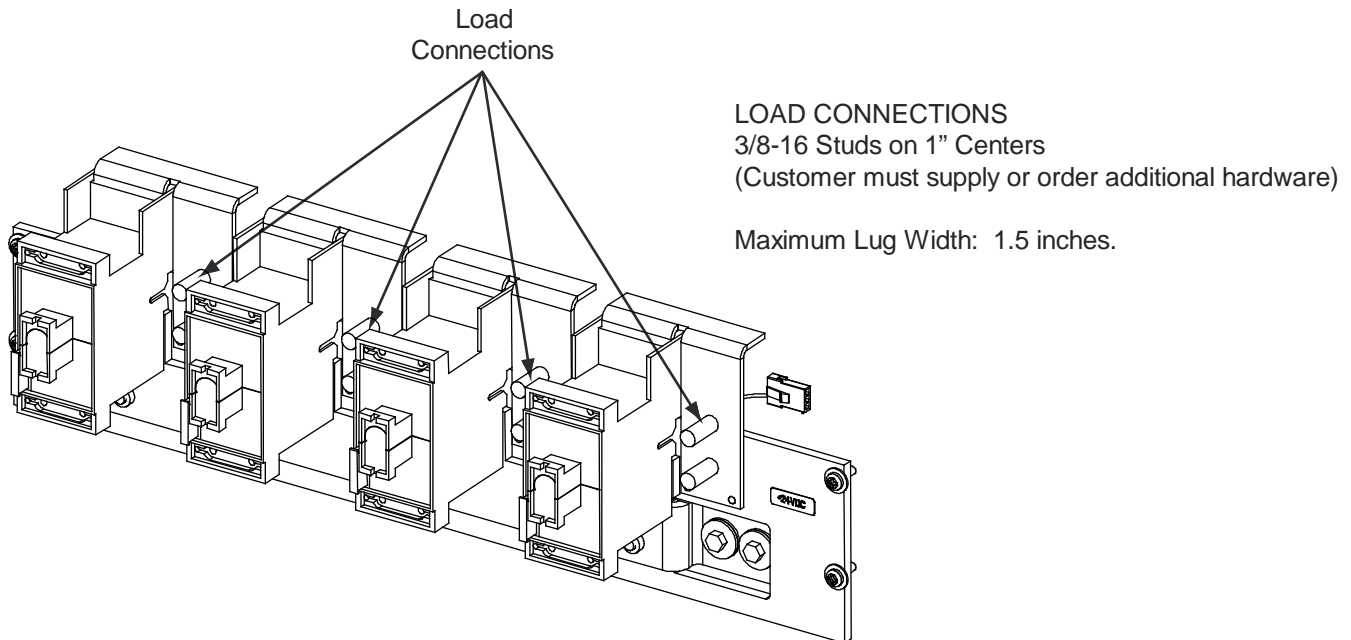

Vertiv™ NetSure™ 710NPBA DC Power System

System Application Guide

List AK: +24 V Distribution Panel,

(4) TPL-B Fuse Positions (with Shunts) (without Return Busbar)

Features

- ◆ (4) +24 V Distribution Fuse Mounting Positions:
70 A to 250 A TPL-B Type Fuses.
- ◆ Includes Shunts, 300 A / 25 mV. Each shunt is equipped with 10' jumpers for connection to monitoring device. If the system is equipped with an SM-DU+, the leads are trimmed and connected to the SM-DU+ (internal to the distribution cabinet).
- ◆ Does NOT include a return busbar.
- ◆ 600 A Maximum Capacity.

Restrictions

Can be installed in any row 1-4 of a 1-, 2-, 3-, or 4-row distribution cabinet.

Maximum lug width, 1.50 inches.

Ordering Notes

- 1) Specify row for panel location(s).
- 2) Order low voltage load disconnect List LL per panel as required.
- 3) To terminate load returns within the distribution cabinet, order List GA as required.
- 4) Order fuses as required per Table 17. Order replacement alarm fuses (18/100 A) per Table 18.
- 5) Order load lugs (two hole, 3/8" bolt clearance hole, 1" centers) as required for each distribution position per Table 23.
- 6) Order lug hardware kit (P/N 548185) as required. Lug hardware kit provides sixteen (16) sets of 3/8-16 hardware (nuts, flat washers, and lock washers), enough for eight (8) lug landing points.

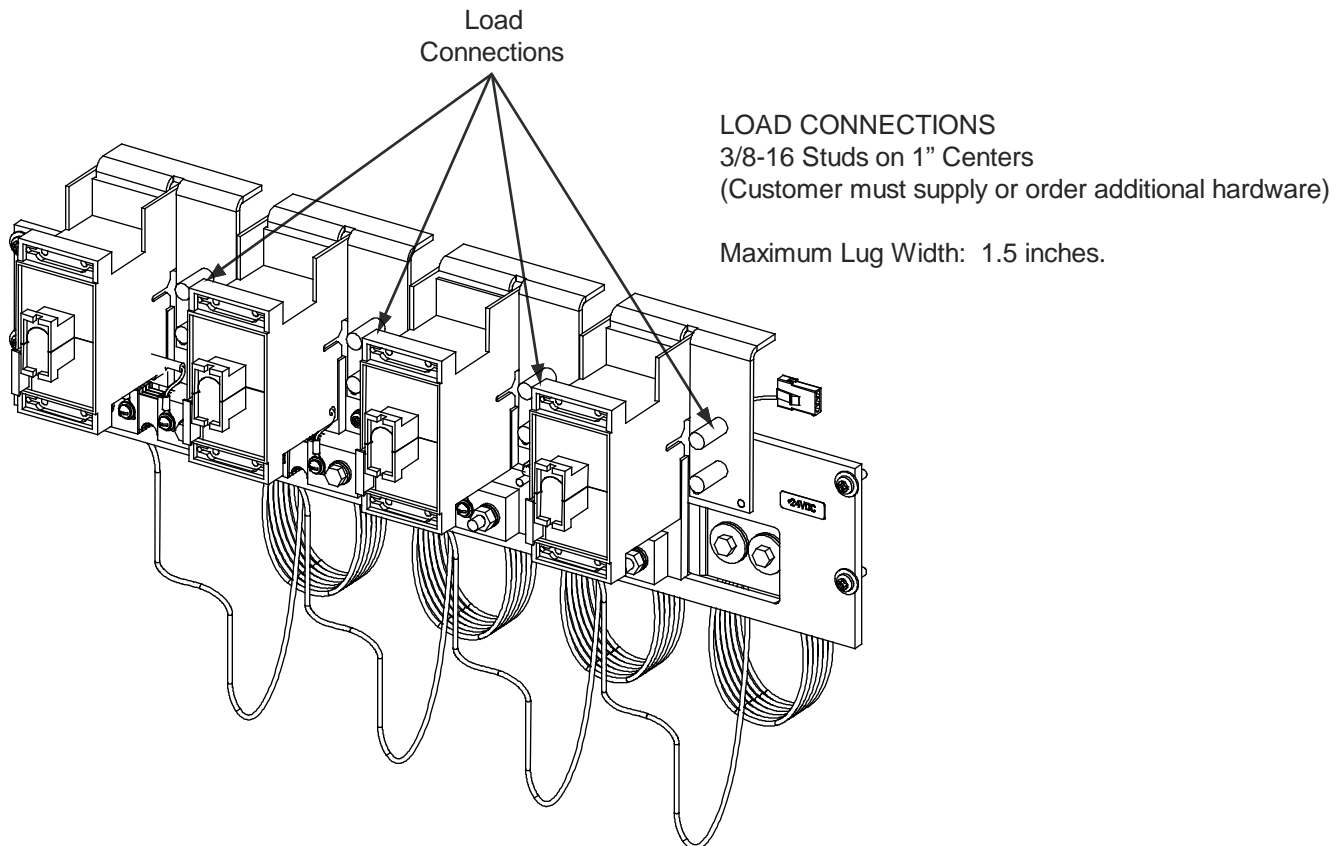

Vertiv™ NetSure™ 710NPBA DC Power System

System Application Guide

List AL: +24 V Distribution Panel (with Return Busbar) and List AN: +24 V Distribution Panel (without Return Busbar) (26) Bullet/TPS/TLS Circuit Breaker/Fuse Positions

Features

- ◆ (26) +24 V Load Distribution Fuse / Circuit Breaker Mounting Positions:
3 A to 100 A TPS/TLS Type Fuses,
1 A to 300 A Bullet Nose Type Circuit Breakers, or accepts
“[Optional Bullet Nose Type 6-Position GMT Distribution Fuse Block \(P/N 549017\)](#)”.
- ◆ List AL includes a return busbar; List AN does not include a return busbar.
- ◆ 600 A Maximum Capacity.

Restrictions

Can be installed in any row 1-4 of a 1-, 2-, 3-, or 4-row distribution cabinet.

Unless otherwise specified fuses and/or circuit breakers are mounted from left to right, starting with the highest capacity and working to the lowest capacity.

125 A, 150 A, 175 A, and 200 A circuit breakers occupy two mounting positions.

225 A, 250 A, and 300 A circuit breakers occupy three mounting positions.

Caution: *A 100 A circuit breaker or fuse SHALL HAVE an empty mounting position between it and any other overcurrent protective device. A 175 A or greater circuit breaker SHALL HAVE an empty mounting position between it and any other overcurrent protective device.*

Maximum lug width, 0.625 inches.

Ordering Notes

- 1) Specify row for panel location(s).
- 2) Order low voltage load disconnect List LL per panel as required.
- 3) List AN: To terminate load returns within the distribution cabinet, order List GA as required.
- 4) Order circuit breakers as required per Table 11 or Table 12.
- 5) Order fuses as required per Table 13. Also order one (1) P/N 117201 bullet nose type fuseholder per fuse ordered. Order replacement alarm fuses (18/100 A) per Table 18.
- 6) Order 6-position GMT fuse block P/N 549017 and fuses per Table 14 as required.
- 7) Order load lugs (two hole, 1/4” bolt clearance hole, 5/8” centers) as required for each distribution position per Table 22.
- 8) Order lug hardware kit (P/N 541084) as required. Lug hardware kit provides thirty-two (32) sets of 1/4-20 hardware (nuts, flat washers, and lock washers), enough for sixteen (16) lug landing points.
- 9) When replacing a List AA, AB, AC, AD, AE, AF, AG, AH, AJ, AK, DA, DB, DC, DD, BA, BB, BC, BD, BE, BF, BG, or BH with a List AL; order busbar per Table 4. Existing busbar required to be replaced with this busbar.

LOAD AND LOAD RETURN CONNECTIONS

1/4-20 Studs on 5/8” Centers
(Customer must supply or
order additional hardware)

Maximum Lug Width: 0.625 inches.

WARNING!

Observe proper
polarity when making
load connections.

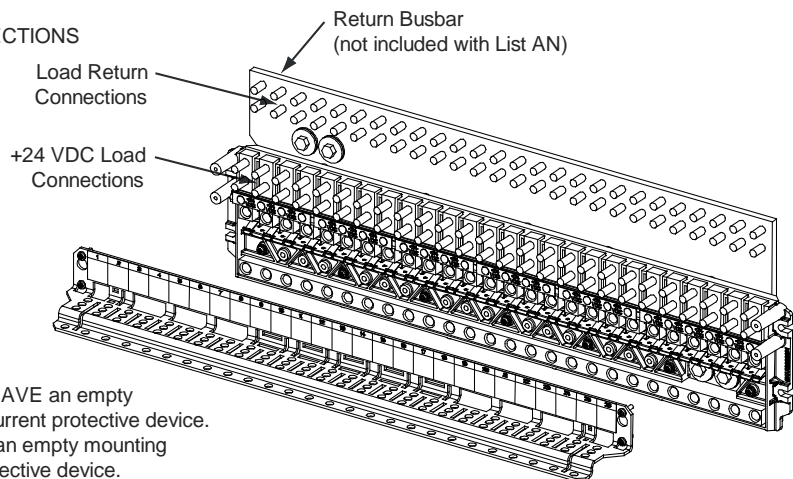

Caution: A 100 A circuit breaker or fuse SHALL HAVE an empty mounting position between it and any other overcurrent protective device.
A 175 A or greater circuit breaker SHALL HAVE an empty mounting position between it and any other overcurrent protective device.

4-Row Distribution Cabinet		
Row	Existing Busbar P/N	New Busbar P/N
4	548274	562432
3	548273	562435
2	548272	562433
1	548271	562434
3-Row Distribution Cabinet		
Row	Existing Busbar P/N	New Busbar P/N
3	548274	562432
2	548272	562433
1	548271	562434
2-Row Distribution Cabinet		
Row	Existing Busbar P/N	New Busbar P/N
2	548273	562507
1	548271	562434
1-Row Distribution Cabinet		
Row	Existing Busbar P/N	New Busbar P/N
1	548271	562434

Table 4

Vertiv™ NetSure™ 710NPBA DC Power System

System Application Guide

List AM: +24 V Distribution Panel (with Return Busbar) and List AP: +24 V Distribution Panel (without Return Busbar) (12) GJ/218 Circuit Breaker Positions

Features

- ◆ (12) +24 V Load Distribution Circuit Breaker Mounting Positions:
100 A to 800 A GJ/218 Type Circuit Breakers.
- ◆ Includes a return busbar.
- ◆ 1600 A Maximum Capacity.
Maximum current rating of each landing point is 360 A.

Restrictions

Unless otherwise specified circuit breakers are mounted from left to right, starting with the highest capacity and working to the lowest capacity.

Can be installed in any two adjacent bus rows 1-2, 2-3, or 3-4 of a 2-, 3-, or 4-row distribution cabinet.

List LL (low voltage load disconnect) is not available with this panel.

Maximum lug width, 1.375 inches.

For an 800 A circuit breaker, continuous load must not exceed 600 A.

Ordering Notes

- 1) Specify rows for panel location(s) (each List AM and List AP requires two rows).
- 2) Order circuit breakers and associated jumper kits as required per Table 15.
- 3) Order load lugs (two hole, 3/8" bolt clearance hole, 1" centers) as required for each distribution position per Table 23.
- 4) Order lug hardware kit (P/N 548184) as required. Lug hardware kit provides sixteen (16) sets of 3/8-16 hardware (bolts, flat washers, and lock washers), enough for eight (8) lug landing points.
- 5) When replacing a List AA, AB, AC, AD, AE, AF, AG, AH, AJ, AK, DA, DB, DC, DD, BA, BB, BC, BD, BE, BF, BG, or BH with a List AM or List AP (return side busbar not required with List AP); order busbars per Table 5. Existing busbars required to be replaced with these busbars.

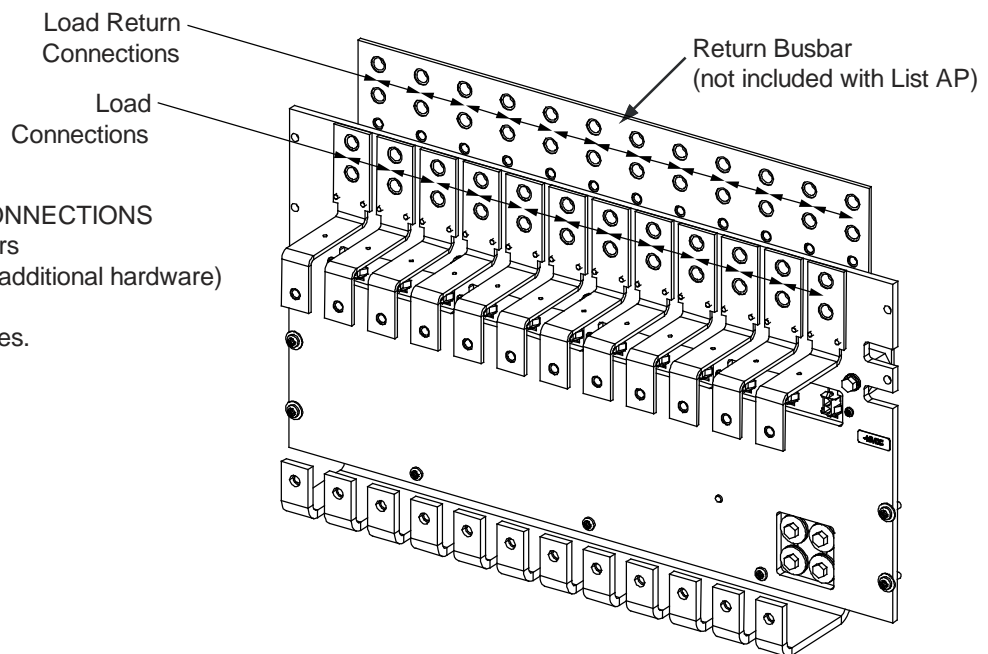

LOAD AND LOAD RETURN CONNECTIONS
3/8-16 Captive Nuts on 1" Centers
(Customer must supply or order additional hardware)

Maximum Lug Width: 1.375 inches.

Vertiv™ NetSure™ 710NPBA DC Power System

System Application Guide

When replacing a List AA, AB, AC, AD, AE, AF, AG, AH, AJ, AK, DA, DB, DC, DD, BA, BB, BC, BD, BE, BF, BG, or BH with List AM or List AP (return side busbar not required with List AP), remove two (2) hot side and two (2) return side busbars from corresponding positions (2-rows) and replace with new busbars ordered from Table 5.

4-Row Distribution Cabinet without LVLD					
Existing Busbar			New Busbar		
Row	Return Side	Hot Side	Row	Return Side	Hot Side
4	548274	561774	3-4	562444	562441
3	548273	561773	2-3	562445	562442
2	548272	561772	1-2	562446	562443
1	548271	562822	--	--	--
3-Row Distribution Cabinet without LVLD					
Existing Busbar			New Busbar		
Row	Return Side	Hot Side	Row	Return Side	Hot Side
3	548274	561774	2-3	562448	562447
2	548272	561881	1-2	562451	562443
1	548271	562822	--	--	--
2-Row Distribution Cabinet without LVLD					
Existing Busbar			New Busbar		
Row	Return Side	Hot Side	Row	Return Side	Hot Side
2	548273	561773	1-2	562449	562443
1	548271	562822	--	--	--

Table 5

Dual Voltage Distribution Panels

List DA: +24 V / -48 V Distribution Panel,

(17) +24 V Bullet/TPS/TLS Circuit Breaker/Fuse Positions (with Return Busbar) and

(4) -48 V Bullet/TPS/TLS Circuit Breaker/Fuse Positions (with Return Busbar)

Features

- ◆ (17) +24 V Load Distribution Fuse / Circuit Breaker Mounting Positions:
(4) -48 V Load Distribution Fuse / Circuit Breaker Mounting Positions:
3 A to 100 A TPS/TLS Type Fuses,
1 A to 300 A Bullet Nose Type Circuit Breakers.
- ◆ Includes a return busbar.
- ◆ 600 A Maximum Total Capacity:
600 A Maximum +24 V Distribution Capacity.
256 A Maximum -48 V Distribution Capacity.

Restrictions

Limit two (2) dual voltage distribution panels per power system. If two dual voltage distribution panels are ordered, they must be mounted in adjacent rows and must be the same List Number. Maximum subsystem current capacity of the second panel is 255 A based on the cables that are provided to connect it to the first panel.

Can be installed in rows 1 to 2 of a 1-, 2-, 3-, or 4-row distribution cabinet.

Unless otherwise specified fuses and/or circuit breakers are mounted from left to right, starting with the highest capacity and working to the lowest capacity.

125 A, 150 A, 175 A, and 200 A circuit breakers occupy two mounting positions.

225 A, 250 A, and 300 A circuit breakers occupy three mounting positions.

Caution: *A 100 A circuit breaker or fuse SHALL HAVE an empty mounting position between it and any other overcurrent protective device. A 175 A or greater circuit breaker SHALL HAVE an empty mounting position between it and any other overcurrent protective device.*

Maximum lug width, 0.625 inches.

Ordering Notes

- 1) Specify row for panel location(s).
- 2) Order low voltage load disconnect List LL (for 24 V positions) as required.
- 3) Order circuit breakers as required per Table 11 or Table 12.
- 4) Order fuses as required per Table 13. Also order one (1) P/N 117201 bullet nose type fuseholder per fuse ordered. Order replacement alarm fuses (18/100 A) per Table 18.
- 5) Order 6-position GMT fuse block P/N 550224 and fuses per Table 14 as required.
- 6) Order load lugs (two hole, 1/4" bolt clearance hole, 5/8" centers) as required for each distribution position per Table 22.
- 7) Order lug hardware kit (P/N 541084) as required. Lug hardware kit provides thirty-two (32) sets of 1/4-20 hardware (nuts, flat washers, and lock washers), enough for sixteen (16) lug landing points.

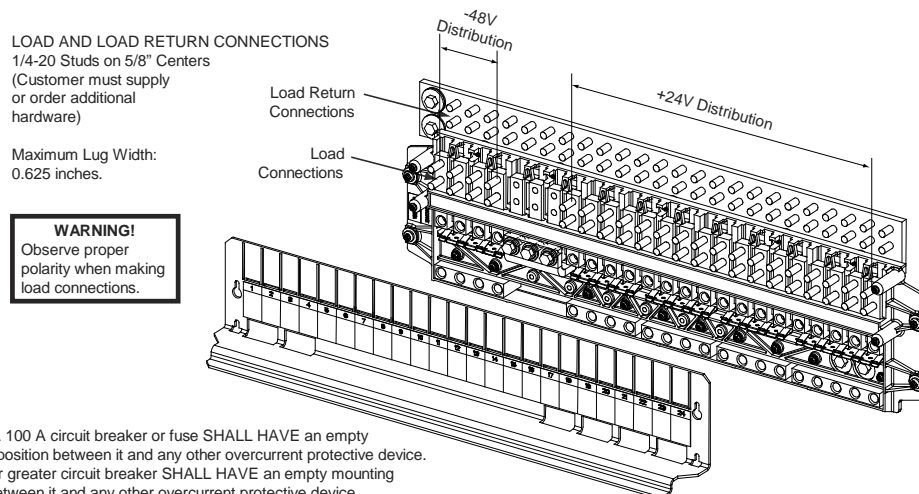

Vertiv™ NetSure™ 710NPBA DC Power System

System Application Guide

List DB: +24 V / -48 V Distribution Panel,

(13) +24 V Bullet/TPS/TLS Circuit Breaker/Fuse Positions (with Return Busbar) and

(8) -48 V Bullet/TPS/TLS Circuit Breaker/Fuse Positions (with Return Busbar)

Features

- ◆ (13) +24 V Load Distribution Fuse / Circuit Breaker Mounting Positions:
(8) -48 V Load Distribution Fuse / Circuit Breaker Mounting Positions:
3 A to 100 A TPS/TLS Type Fuses,
1 A to 300 A Bullet Nose Type Circuit Breakers.
- ◆ Includes a return busbar.
- ◆ 600 A Maximum Total Capacity:
600 A Maximum +24 V Distribution Capacity.
500 A Maximum -48 V Distribution Capacity.

Restrictions

Limit two (2) dual voltage distribution panels per power system. If two dual voltage distribution panels are ordered, they must be mounted in adjacent rows and must be the same List Number. Maximum subsystem current capacity of the second panel is 255 A based on the cables that are provided to connect it to the first panel.

Can be installed in rows 1 to 2 of a 1-, 2-, 3-, or 4-row distribution cabinet.

Unless otherwise specified fuses and/or circuit breakers are mounted from left to right, starting with the highest capacity and working to the lowest capacity.

125 A, 150 A, 175 A, and 200 A circuit breakers occupy two mounting positions.

225 A, 250 A, and 300 A circuit breakers occupy three mounting positions.

Caution: *A 100 A circuit breaker or fuse SHALL HAVE an empty mounting position between it and any other overcurrent protective device. A 175 A or greater circuit breaker SHALL HAVE an empty mounting position between it and any other overcurrent protective device.*

Maximum lug width, 0.625 inches.

Ordering Notes

- 1) Specify row for panel location(s).
- 2) Order low voltage load disconnect List LL (for 24 V positions) as required.
- 3) Order circuit breakers as required per Table 11 or Table 12.
- 4) Order fuses as required per Table 13. Also order one (1) P/N 117201 bullet nose type fuseholder per fuse ordered. Order replacement alarm fuses (18/100 A) per Table 18.
- 5) Order 6-position GMT fuse block P/N 550224 and fuses per Table 14 as required.
- 6) Order load lugs (two hole, 1/4" bolt clearance hole, 5/8" centers) as required for each distribution position per Table 22.
- 7) Order lug hardware kit (P/N 541084) as required. Lug hardware kit provides thirty-two (32) sets of 1/4-20 hardware (nuts, flat washers, and lock washers), enough for sixteen (16) lug landing points.

LOAD AND LOAD RETURN CONNECTIONS

1/4-20 Studs on 5/8" Centers
(Customer must supply
or order additional
hardware)

Maximum Lug Width:
0.625 inches.

WARNING!
Observe proper
polarity when making
load connections.

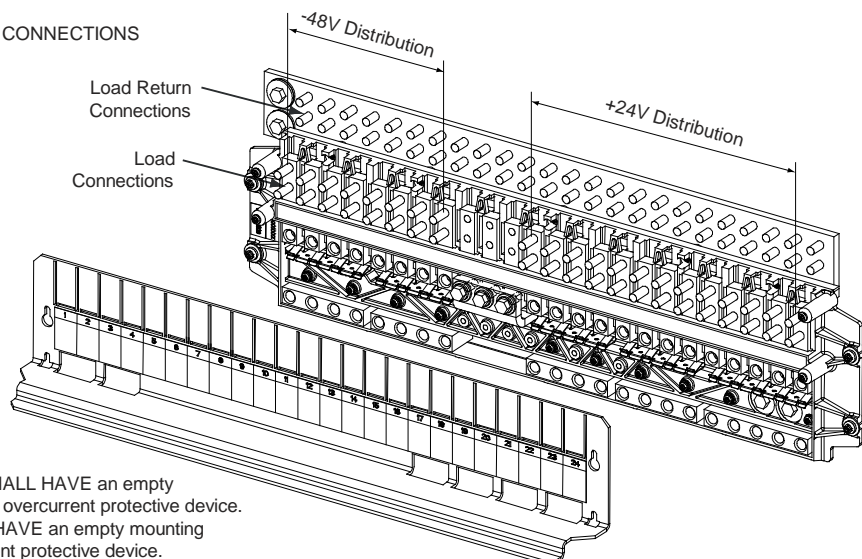

Caution: A 100 A circuit breaker or fuse SHALL HAVE an empty mounting position between it and any other overcurrent protective device.
A 175 A or greater circuit breaker SHALL HAVE an empty mounting position between it and any other overcurrent protective device.

Vertiv™ NetSure™ 710NPBA DC Power System

System Application Guide

List DC: +24 V / -48 V Distribution Panel,

(9) +24 V Bullet/TPS/TLS Circuit Breaker/Fuse Positions (with Return Busbar) and

(12) -48 V Bullet/TPS/TLS Circuit Breaker/Fuse Positions (with Return Busbar)

Features

- ◆ (9) +24 V Load Distribution Fuse / Circuit Breaker Mounting Positions:
(12) -48 V Load Distribution Fuse / Circuit Breaker Mounting Positions:
3 A to 100 A TPS/TLS Type Fuses,
1 A to 300 A Bullet Nose Type Circuit Breakers.
- ◆ Includes a return busbar.
- ◆ 600 A Maximum Total Capacity:
576 A Maximum +24 V Distribution Capacity.
500 A Maximum -48 V Distribution Capacity.

Restrictions

Limit two (2) dual voltage distribution panels per power system. If two dual voltage distribution panels are ordered, they must be mounted in adjacent rows and must be the same List Number. Maximum subsystem current capacity of the second panel is 255 A based on the cables that are provided to connect it to the first panel.

Can be installed in rows 1 to 2 of a 1-, 2-, 3-, or 4-row distribution cabinet.

Unless otherwise specified fuses and/or circuit breakers are mounted from left to right, starting with the highest capacity and working to the lowest capacity.

125 A, 150 A, 175 A, and 200 A circuit breakers occupy two mounting positions.

225 A, 250 A, and 300 A circuit breakers occupy three mounting positions.

Caution: *A 100 A circuit breaker or fuse SHALL HAVE an empty mounting position between it and any other overcurrent protective device. A 175 A or greater circuit breaker SHALL HAVE an empty mounting position between it and any other overcurrent protective device.*

Maximum lug width, 0.625 inches.

Ordering Notes

- 1) Specify row for panel location(s).
- 2) Order low voltage load disconnect List LL (for 24 V positions) as required.
- 3) Order circuit breakers as required per Table 11 or Table 12.
- 4) Order fuses as required per Table 13. Also order one (1) P/N 117201 bullet nose type fuseholder per fuse ordered. Order replacement alarm fuses (18/100 A) per Table 18.
- 5) Order 6-position GMT fuse block P/N 550224 and fuses per Table 14 as required.
- 6) Order load lugs (two hole, 1/4" bolt clearance hole, 5/8" centers) as required for each distribution position per Table 22.
- 7) Order lug hardware kit (P/N 541084) as required. Lug hardware kit provides thirty-two (32) sets of 1/4-20 hardware (nuts, flat washers, and lock washers), enough for sixteen (16) lug landing points.

LOAD AND LOAD RETURN CONNECTIONS

1/4-20 Studs on 5/8" Centers
(Customer must supply
or order additional
hardware)

Maximum Lug Width:
0.625 inches.

WARNING!
Observe proper
polarity when making
load connections.

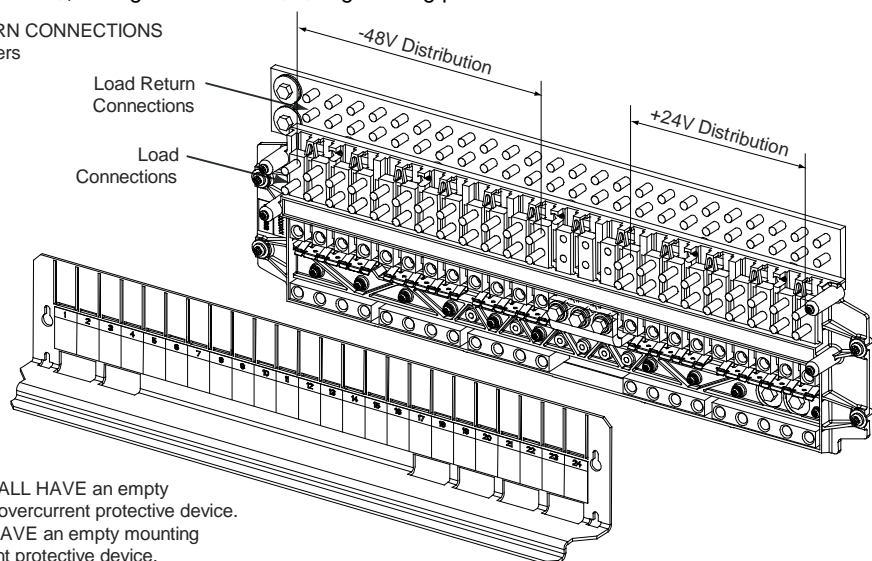

Caution: A 100 A circuit breaker or fuse SHALL HAVE an empty mounting position between it and any other overcurrent protective device.
A 175 A or greater circuit breaker SHALL HAVE an empty mounting position between it and any other overcurrent protective device.

Vertiv™ NetSure™ 710NPBA DC Power System

System Application Guide

List DD: +24 V / -48 V Distribution Panel,

(5) +24 V Bullet/TPS/TLS Circuit Breaker/Fuse Positions (with Return Busbar) and

(16) -48 V Bullet/TPS/TLS Circuit Breaker/Fuse Positions (with Return Busbar)

Features

- ◆ (5) +24 V Load Distribution Fuse / Circuit Breaker Mounting Positions:
(16) -48 V Load Distribution Fuse / Circuit Breaker Mounting Positions:
3 A to 100 A TPS/TLS Type Fuses,
1 A to 300 A Bullet Nose Type Circuit Breakers.
- ◆ Includes a return busbar.
- ◆ 600 A Maximum Total Capacity:
320 A Maximum +24 V Distribution Capacity.
500 A Maximum -48 V Distribution Capacity.

Restrictions

Limit two (2) dual voltage distribution panels per power system. If two dual voltage distribution panels are ordered, they must be mounted in adjacent rows and must be the same List Number. Maximum subsystem current capacity of the second panel is 255 A based on the cables that are provided to connect it to the first panel.

Can be installed in rows 1 to 2 of a 1-, 2-, 3-, or 4-row distribution cabinet.

Unless otherwise specified fuses and/or circuit breakers are mounted from left to right, starting with the highest capacity and working to the lowest capacity.

125 A, 150 A, 175 A, and 200 A circuit breakers occupy two mounting positions.

225 A, 250 A, and 300 A circuit breakers occupy three mounting positions.

Caution: *A 100 A circuit breaker or fuse SHALL HAVE an empty mounting position between it and any other overcurrent protective device. A 175 A or greater circuit breaker SHALL HAVE an empty mounting position between it and any other overcurrent protective device.*

Maximum lug width, 0.625 inches.

Ordering Notes

- 1) Specify row for panel location(s).
- 2) Order low voltage load disconnect List LL (for 24 V positions) as required.
- 3) Order circuit breakers as required per Table 11 or Table 12.
- 4) Order fuses as required per Table 13. Also order one (1) P/N 117201 bullet nose type fuseholder per fuse ordered. Order replacement alarm fuses (18/100 A) per Table 18.
- 5) Order 6-position GMT fuse block P/N 550224 and fuses per Table 14 as required.
- 6) Order load lugs (two hole, 1/4" bolt clearance hole, 5/8" centers) as required for each distribution position per Table 22.
- 7) Order lug hardware kit (P/N 541084) as required. Lug hardware kit provides thirty-two (32) sets of 1/4-20 hardware (nuts, flat washers, and lock washers), enough for sixteen (16) lug landing points.

LOAD AND LOAD RETURN CONNECTIONS

1/4-20 Studs on 5/8" Centers
(Customer must supply
or order additional
hardware)

Maximum Lug Width:
0.625 inches.

WARNING!
Observe proper
polarity when making
load connections.

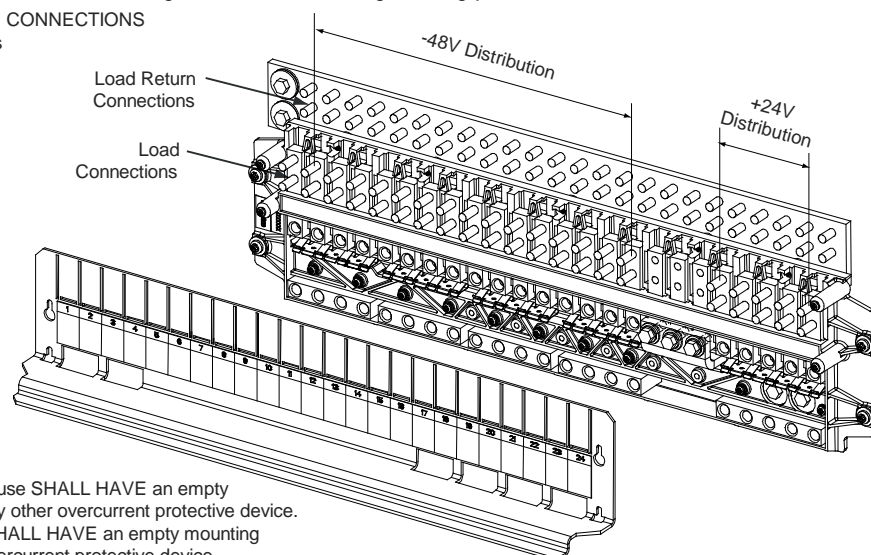

Caution: A 100 A circuit breaker or fuse SHALL HAVE an empty mounting position between it and any other overcurrent protective device.
A 175 A or greater circuit breaker SHALL HAVE an empty mounting position between it and any other overcurrent protective device.

Vertiv™ NetSure™ 710NPBA DC Power System

System Application Guide

List DE: +24 V / -48 V Distribution Panel, (22) +24 V Bullet/TPS/TLS Circuit Breaker/Fuse Positions (with Return Busbar) and (4) -48 V Bullet/TPS/TLS Circuit Breaker/Fuse Positions (with Return Busbar)

Features

- ◆ (22) +24 V Load Distribution Fuse / Circuit Breaker Mounting Positions:
(4) -48 V Load Distribution Fuse / Circuit Breaker Mounting Positions:
3 A to 100 A TPS/TLS Type Fuses,
1 A to 300 A Bullet Nose Type Circuit Breakers.
- ◆ Includes a return busbar.
- ◆ 600 A Maximum Total Capacity:
600 A Maximum +24 V Distribution Capacity.
500 A Maximum -48 V Distribution Capacity.

Restrictions

Limit two (2) dual voltage distribution panels per power system. If two dual voltage distribution panels are ordered, they must be mounted in adjacent rows. Maximum subsystem current capacity of the second panel is 255 A based on the cables that are provided to connect it to the first panel.

Can be installed in any row of a 1-, 2-, 3-, or 4-row distribution cabinet.

Unless otherwise specified fuses and/or circuit breakers are mounted from left to right, starting with the highest capacity and working to the lowest capacity.

125 A, 150 A, 175 A, and 200 A circuit breakers occupy two mounting positions.

225 A, 250 A, and 300 A circuit breakers occupy three mounting positions.

Caution: *A 100 A circuit breaker or fuse SHALL HAVE an empty mounting position between it and any other overcurrent protective device. A 175 A or greater circuit breaker SHALL HAVE an empty mounting position between it and any other overcurrent protective device.*

Maximum lug width, 0.625 inches.

Ordering Notes

- 1) Specify row for panel location(s).
- 2) Order low voltage load disconnect List LL (for 24 V positions) as required.
- 3) Order circuit breakers as required per Table 11 or Table 12.
- 4) Order fuses as required per Table 13. Also order one (1) P/N 117201 bullet nose type fuseholder per fuse ordered. Order replacement alarm fuses (18/100 A) per Table 18.
- 5) Order 6-position GMT fuse block P/N 549017 and fuses per Table 14 as required.
- 6) Order load lugs (two hole, 1/4" bolt clearance hole, 5/8" centers) as required for each distribution position per Table 22.
- 7) Order lug hardware kit (P/N 541084) as required. Lug hardware kit provides thirty-two (32) sets of 1/4-20 hardware (nuts, flat washers, and lock washers), enough for sixteen (16) lug landing points.
- 8) When replacing a List AA, AB, AC, AD, AE, AF, AG, AH, AJ, AK, DA, DB, DC, DD, BA, BB, BC, BD, BE, BF, BG, or BH with this panel; order busbar per Table 4. Existing busbar required to be replaced with this busbar.

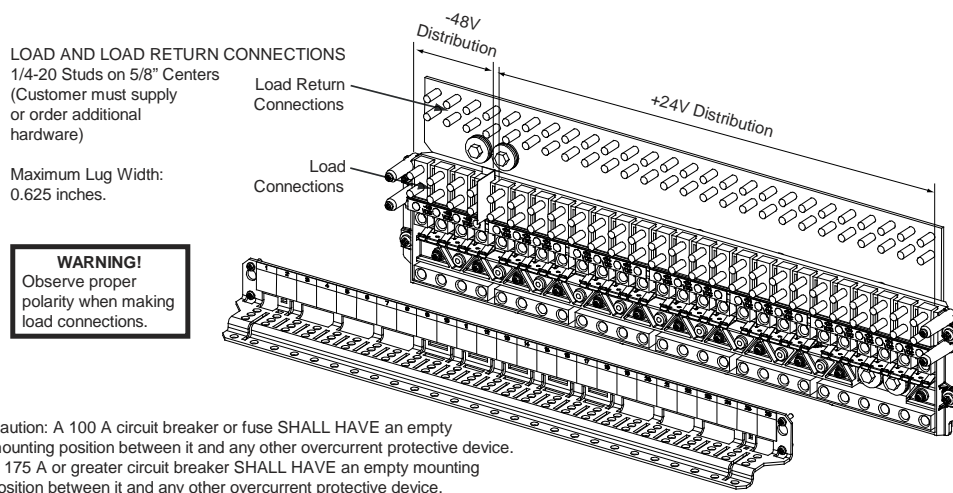

Vertiv™ NetSure™ 710NPBA DC Power System

System Application Guide

List DF: +24 V / -48 V Distribution Panel,

(18) +24 V Bullet/TPS/TLS Circuit Breaker/Fuse Positions (with Return Busbar) and (8) -48 V Bullet/TPS/TLS Circuit Breaker/Fuse Positions (with Return Busbar)

Features

- ◆ (18) +24 V Load Distribution Fuse / Circuit Breaker Mounting Positions:
(8) -48 V Load Distribution Fuse / Circuit Breaker Mounting Positions:
3 A to 100 A TPS/TLS Type Fuses,
1 A to 300 A Bullet Nose Type Circuit Breakers.
- ◆ Includes a return busbar.
- ◆ 600 A Maximum Total Capacity:
600 A Maximum +24 V Distribution Capacity.
500 A Maximum -48 V Distribution Capacity.

Restrictions

Limit two (2) dual voltage distribution panels per power system. If two dual voltage distribution panels are ordered, they must be mounted in adjacent rows. Maximum subsystem current capacity of the second panel is 255 A based on the cables that are provided to connect it to the first panel.

Can be installed in any row of a 1-, 2-, 3-, or 4-row distribution cabinet.

Unless otherwise specified fuses and/or circuit breakers are mounted from left to right, starting with the highest capacity and working to the lowest capacity.

125 A, 150 A, 175 A, and 200 A circuit breakers occupy two mounting positions.

225 A, 250 A, and 300 A circuit breakers occupy three mounting positions.

Caution: *A 100 A circuit breaker or fuse SHALL HAVE an empty mounting position between it and any other overcurrent protective device. A 175 A or greater circuit breaker SHALL HAVE an empty mounting position between it and any other overcurrent protective device.*

Maximum lug width, 0.625 inches.

Ordering Notes

- 1) Specify row for panel location(s).
- 2) Order low voltage load disconnect List LL (for 24 V positions) as required.
- 3) Order circuit breakers as required per Table 11 or Table 12.
- 4) Order fuses as required per Table 13. Also order one (1) P/N 117201 bullet nose type fuseholder per fuse ordered. Order replacement alarm fuses (18/100 A) per Table 18.
- 5) Order 6-position GMT fuse block P/N 549017 and fuses per Table 14 as required.
- 6) Order load lugs (two hole, 1/4" bolt clearance hole, 5/8" centers) as required for each distribution position per Table 22.
- 7) Order lug hardware kit (P/N 541084) as required. Lug hardware kit provides thirty-two (32) sets of 1/4-20 hardware (nuts, flat washers, and lock washers), enough for sixteen (16) lug landing points.
- 8) When replacing a List AA, AB, AC, AD, AE, AF, AG, AH, AJ, AK, DA, DB, DC, DD, BA, BB, BC, BD, BE, BF, BG, or BH with this panel; order busbar per Table 4. Existing busbar required to be replaced with this busbar.

LOAD AND LOAD RETURN CONNECTIONS
1/4-20 Studs on 5/8" Centers
(Customer must supply
or order additional
hardware)

Maximum Lug Width:
0.625 inches.

WARNING!
Observe proper
polarity when making
load connections.

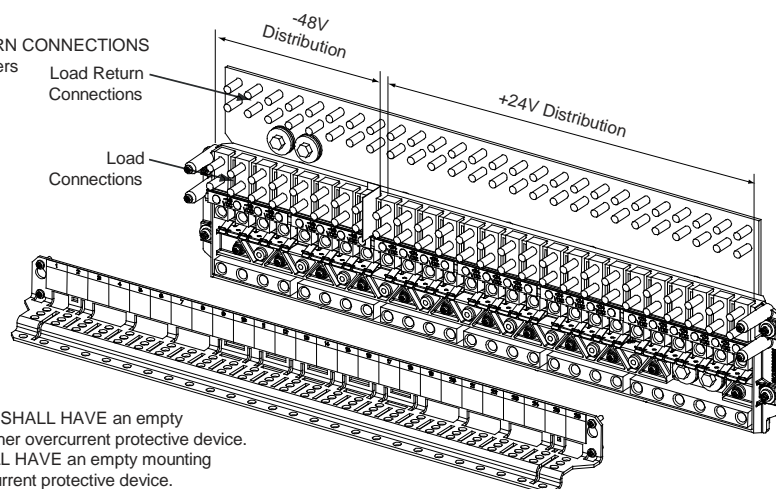

Caution: A 100 A circuit breaker or fuse SHALL HAVE an empty mounting position between it and any other overcurrent protective device.
A 175 A or greater circuit breaker SHALL HAVE an empty mounting position between it and any other overcurrent protective device.

Vertiv™ NetSure™ 710NPBA DC Power System

System Application Guide

List DG: +24 V / -48 V Distribution Panel,

(14) +24 V Bullet/TPS/TLS Circuit Breaker/Fuse Positions (with Return Busbar) and

(12) -48 V Bullet/TPS/TLS Circuit Breaker/Fuse Positions (with Return Busbar)

Features

- ◆ (14) +24 V Load Distribution Fuse / Circuit Breaker Mounting Positions:
(12) -48 V Load Distribution Fuse / Circuit Breaker Mounting Positions:
3 A to 100 A TPS/TLS Type Fuses,
1 A to 300 A Bullet Nose Type Circuit Breakers.
- ◆ Includes a return busbar.
- ◆ 600 A Maximum Total Capacity:
600 A Maximum +24 V Distribution Capacity.
500 A Maximum -48 V Distribution Capacity.

Restrictions

Limit two (2) dual voltage distribution panels per power system. If two dual voltage distribution panels are ordered, they must be mounted in adjacent rows. Maximum subsystem current capacity of the second panel is 255 A based on the cables that are provided to connect it to the first panel.

Can be installed in any row of a 1-, 2-, 3-, or 4-row distribution cabinet.

Unless otherwise specified fuses and/or circuit breakers are mounted from left to right, starting with the highest capacity and working to the lowest capacity.

125 A, 150 A, 175 A, and 200 A circuit breakers occupy two mounting positions.

225 A, 250 A, and 300 A circuit breakers occupy three mounting positions.

Caution: *A 100 A circuit breaker or fuse SHALL HAVE an empty mounting position between it and any other overcurrent protective device. A 175 A or greater circuit breaker SHALL HAVE an empty mounting position between it and any other overcurrent protective device.*

Maximum lug width, 0.625 inches.

Ordering Notes

- 1) Specify row for panel location(s).
- 2) Order low voltage load disconnect List LL (for 24 V positions) as required.
- 3) Order circuit breakers as required per Table 11 or Table 12.
- 4) Order fuses as required per Table 13. Also order one (1) P/N 117201 bullet nose type fuseholder per fuse ordered. Order replacement alarm fuses (18/100 A) per Table 18.
- 5) Order 6-position GMT fuse block P/N 549017 and fuses per Table 14 as required.
- 6) Order load lugs (two hole, 1/4" bolt clearance hole, 5/8" centers) as required for each distribution position per Table 22.
- 7) Order lug hardware kit (P/N 541084) as required. Lug hardware kit provides thirty-two (32) sets of 1/4-20 hardware (nuts, flat washers, and lock washers), enough for sixteen (16) lug landing points.
- 8) When replacing a List AA, AB, AC, AD, AE, AF, AG, AH, AJ, AK, DA, DB, DC, DD, BA, BB, BC, BD, BE, BF, BG, or BH with this panel; order busbar per Table 4. Existing busbar required to be replaced with this busbar.

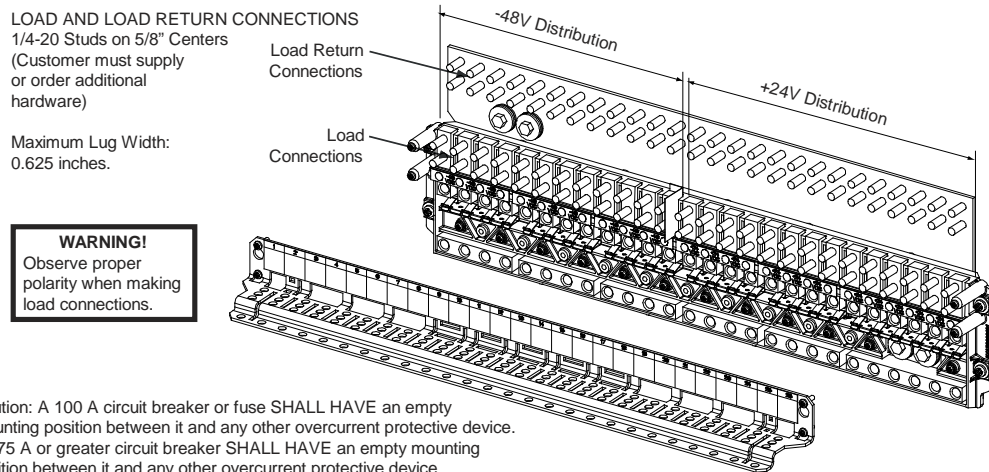

Vertiv™ NetSure™ 710NPBA DC Power System

System Application Guide

List DH: +24 V / -48 V Distribution Panel,

(10) +24 V Bullet/TPS/TLS Circuit Breaker/Fuse Positions (with Return Busbar) and

(16) -48 V Bullet/TPS/TLS Circuit Breaker/Fuse Positions (with Return Busbar)

Features

- ◆ (10) +24 V Load Distribution Fuse / Circuit Breaker Mounting Positions:
(16) -48 V Load Distribution Fuse / Circuit Breaker Mounting Positions:
3 A to 100 A TPS/TLS Type Fuses,
1 A to 300 A Bullet Nose Type Circuit Breakers.
- ◆ Includes a return busbar.
- ◆ 600 A Maximum Total Capacity:
600 A Maximum +24 V Distribution Capacity.
500 A Maximum -48 V Distribution Capacity.

Restrictions

Limit two (2) dual voltage distribution panels per power system. If two dual voltage distribution panels are ordered, they must be mounted in adjacent rows. Maximum subsystem current capacity of the second panel is 255 A based on the cables that are provided to connect it to the first panel.

Can be installed in any row of a 1-, 2-, 3-, or 4-row distribution cabinet.

Unless otherwise specified fuses and/or circuit breakers are mounted from left to right, starting with the highest capacity and working to the lowest capacity.

125 A, 150 A, 175 A, and 200 A circuit breakers occupy two mounting positions.

225 A, 250 A, and 300 A circuit breakers occupy three mounting positions.

Caution: *A 100 A circuit breaker or fuse SHALL HAVE an empty mounting position between it and any other overcurrent protective device. A 175 A or greater circuit breaker SHALL HAVE an empty mounting position between it and any other overcurrent protective device.*

Maximum lug width, 0.625 inches.

Ordering Notes

- 1) Specify row for panel location(s).
- 2) Order low voltage load disconnect List LL (for 24 V positions) as required.
- 3) Order circuit breakers as required per Table 11 or Table 12.
- 4) Order fuses as required per Table 13. Also order one (1) P/N 117201 bullet nose type fuseholder per fuse ordered. Order replacement alarm fuses (18/100 A) per Table 18.
- 5) Order 6-position GMT fuse block P/N 549017 and fuses per Table 14 as required.
- 6) Order load lugs (two hole, 1/4" bolt clearance hole, 5/8" centers) as required for each distribution position per Table 22.
- 7) Order lug hardware kit (P/N 541084) as required. Lug hardware kit provides thirty-two (32) sets of 1/4-20 hardware (nuts, flat washers, and lock washers), enough for sixteen (16) lug landing points.
- 8) When replacing a List AA, AB, AC, AD, AE, AF, AG, AH, AJ, AK, DA, DB, DC, DD, BA, BB, BC, BD, BE, BF, BG, or BH with this panel; order busbar per Table 4. Existing busbar required to be replaced with this busbar.

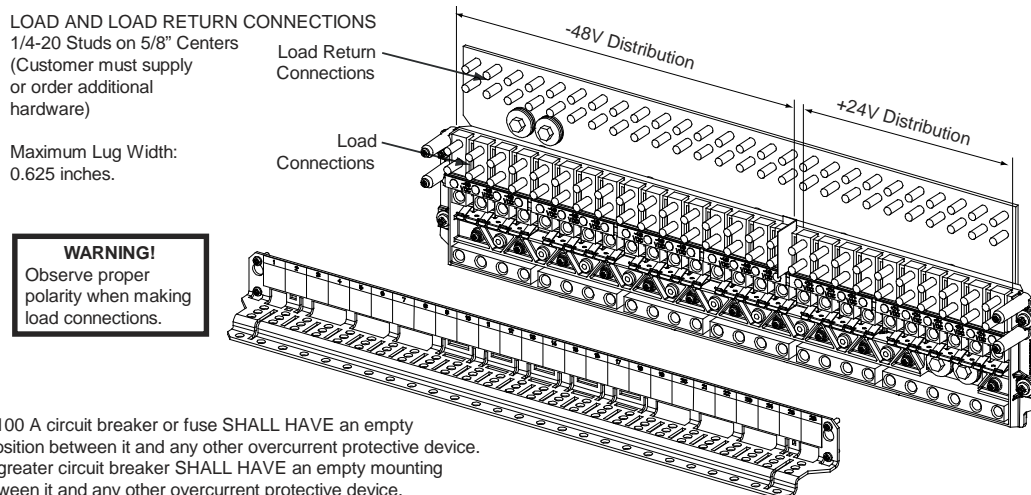

Vertiv™ NetSure™ 710NPBA DC Power System

System Application Guide

List DJ: +24 V / -48 V Distribution Panel,

(6) +24 V Bullet/TPS/TLS Circuit Breaker/Fuse Positions (with Return Busbar) and

(20) -48 V Bullet/TPS/TLS Circuit Breaker/Fuse Positions (with Return Busbar)

Features

- ◆ (6) +24 V Load Distribution Fuse / Circuit Breaker Mounting Positions:
(20) -48 V Load Distribution Fuse / Circuit Breaker Mounting Positions:
3 A to 100 A TPS/TLS Type Fuses,
1 A to 300 A Bullet Nose Type Circuit Breakers.
- ◆ Includes a return busbar.
- ◆ 600 A Maximum Total Capacity:
600 A Maximum +24 V Distribution Capacity.
500 A Maximum -48 V Distribution Capacity.

Restrictions

Limit two (2) dual voltage distribution panels per power system. If two dual voltage distribution panels are ordered, they must be mounted in adjacent rows. Maximum subsystem current capacity of the second panel is 255 A based on the cables that are provided to connect it to the first panel.

Can be installed in any row of a 1-, 2-, 3-, or 4-row distribution cabinet with the following exception: cannot be installed in row 1 when an LVD contactor is installed in row 1.

Unless otherwise specified fuses and/or circuit breakers are mounted from left to right, starting with the highest capacity and working to the lowest capacity.

125 A, 150 A, 175 A, and 200 A circuit breakers occupy two mounting positions.

225 A, 250 A, and 300 A circuit breakers occupy three mounting positions.

Caution: *A 100 A circuit breaker or fuse SHALL HAVE an empty mounting position between it and any other overcurrent protective device. A 175 A or greater circuit breaker SHALL HAVE an empty mounting position between it and any other overcurrent protective device.*

Maximum lug width, 0.625 inches.

Ordering Notes

- 1) Specify row for panel location(s).
- 2) Order low voltage load disconnect List LL (for 24 V positions) as required.
- 3) Order circuit breakers as required per Table 11 or Table 12.
- 4) Order fuses as required per Table 13. Also order one (1) P/N 117201 bullet nose type fuseholder per fuse ordered. Order replacement alarm fuses (18/100 A) per Table 18.
- 5) Order 6-position GMT fuse block P/N 549017 and fuses per Table 14 as required.
- 6) Order load lugs (two hole, 1/4" bolt clearance hole, 5/8" centers) as required for each distribution position per Table 22.
- 7) Order lug hardware kit (P/N 541084) as required. Lug hardware kit provides thirty-two (32) sets of 1/4-20 hardware (nuts, flat washers, and lock washers), enough for sixteen (16) lug landing points.
- 8) When replacing a List AA, AB, AC, AD, AE, AF, AG, AH, AJ, AK, DA, DB, DC, DD, BA, BB, BC, BD, BE, BF, BG, or BH with this panel; order busbar per Table 4. Existing busbar required to be replaced with this busbar.

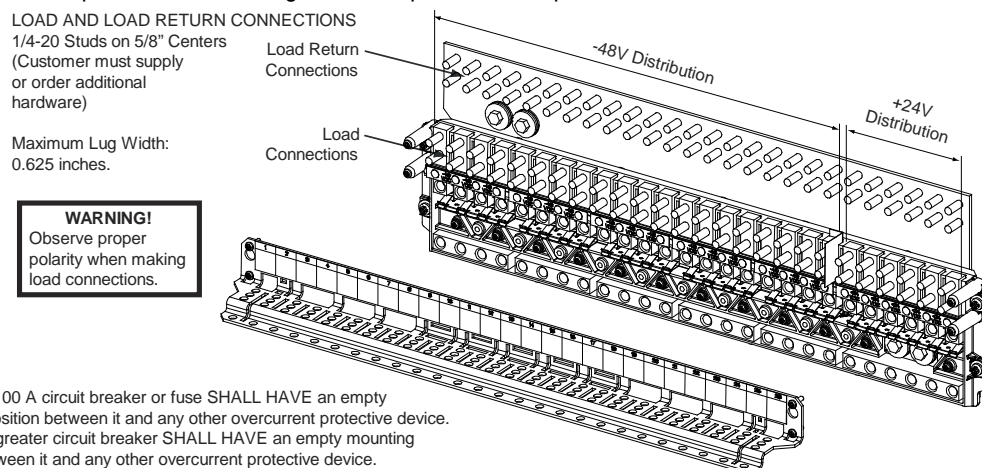

Vertiv™ NetSure™ 710NPBA DC Power System

System Application Guide

List DK: +24 V / -48 V Distribution Panel,

(26) -48 V Bullet/TPS/TLS Circuit Breaker/Fuse Positions (with Return Busbar)

Features

- ◆ (26) -48 V Load Distribution Fuse / Circuit Breaker Mounting Positions:
3 A to 100 A TPS/TLS Type Fuses,
1 A to 300 A Bullet Nose Type Circuit Breakers.
- ◆ Includes a return busbar.
- ◆ 500 A Maximum -48 V Distribution Capacity.
If reconfigured in the field; 600 A Maximum Total Capacity:
600 A Maximum +24 V Distribution Capacity.
500 A Maximum -48 V Distribution Capacity.

Restrictions

Limit two (2) dual voltage distribution panels per power system. If two dual voltage distribution panels are ordered, they must be mounted in adjacent rows. Maximum subsystem current capacity of the second panel is 255 A based on the cables that are provided to connect it to the first panel.

Can be installed in any row of a 1-, 2-, 3-, or 4-row distribution cabinet.

Unless otherwise specified fuses and/or circuit breakers are mounted from left to right, starting with the highest capacity and working to the lowest capacity.

125 A, 150 A, 175 A, and 200 A circuit breakers occupy two mounting positions.

225 A, 250 A, and 300 A circuit breakers occupy three mounting positions.

Caution: *A 100 A circuit breaker or fuse SHALL HAVE an empty mounting position between it and any other overcurrent protective device. A 175 A or greater circuit breaker SHALL HAVE an empty mounting position between it and any other overcurrent protective device.*

Maximum lug width, 0.625 inches.

Ordering Notes

- 1) Specify row for panel location(s).
- 2) Order circuit breakers as required per Table 11 or Table 12.
- 3) Order fuses as required per Table 13. Also order one (1) P/N 117201 bullet nose type fuseholder per fuse ordered. Order replacement alarm fuses (18/100 A) per Table 18.
- 4) Order 6-position GMT fuse block P/N 549017 and fuses per Table 14 as required.
- 5) Order load lugs (two hole, 1/4" bolt clearance hole, 5/8" centers) as required for each distribution position per Table 22.
- 6) Order lug hardware kit (P/N 541084) as required. Lug hardware kit provides thirty-two (32) sets of 1/4-20 hardware (nuts, flat washers, and lock washers), enough for sixteen (16) lug landing points.
- 7) When replacing a List AA, AB, AC, AD, AE, AF, AG, AH, AJ, AK, DA, DB, DC, DD, BA, BB, BC, BD, BE, BF, BG, or BH with this panel; order busbar per Table 4. Existing busbar required to be replaced with this busbar.

LOAD AND LOAD RETURN CONNECTIONS
1/4-20 Studs on 5/8" Centers
(Customer must supply
or order additional
hardware)

Maximum Lug Width:
0.625 inches.

WARNING!
Observe proper
polarity when making
load connections.

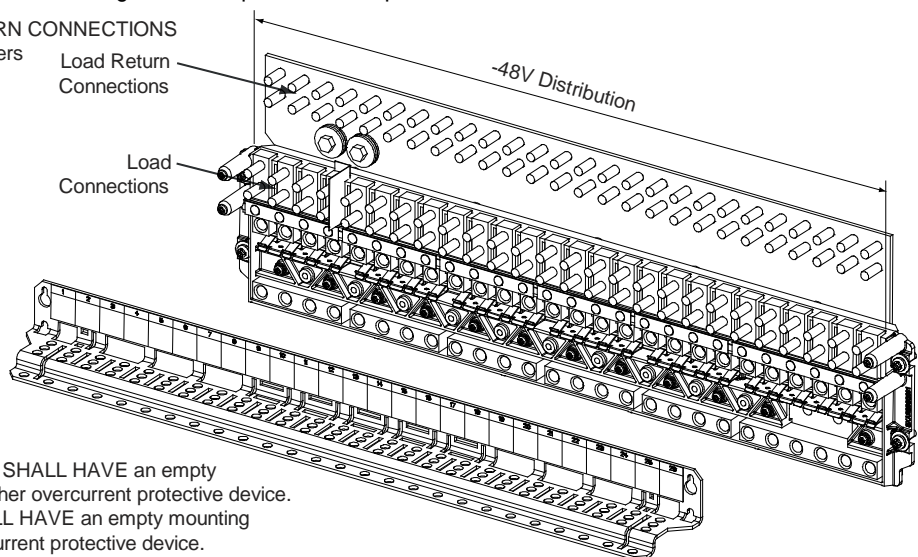

Caution: A 100 A circuit breaker or fuse SHALL HAVE an empty mounting position between it and any other overcurrent protective device.
A 175 A or greater circuit breaker SHALL HAVE an empty mounting position between it and any other overcurrent protective device.

Battery Disconnect Distribution Panels

List BA: Battery Disconnect Distribution Panel (with Return Busbar) and

List BB: Battery Disconnect Distribution Panel (without Return Busbar).

(24) Bullet/TPS/TLS Circuit Breaker/Fuse Battery Disconnect Positions

Features

- ◆ (24) +24 V Battery Disconnect Fuse / Circuit Breaker Mounting Positions:
3 A to 100 A TPS/TLS Type Fuses,
1 A to 300 A Bullet Nose Type Circuit Breakers.
- ◆ List BA includes a return busbar; List BB does not include a return busbar.
- ◆ 600 A Maximum Capacity.

Restrictions

Cannot be used with List 21.

Must be installed in top row only (limit one battery disconnect distribution panel per distribution cabinet).

Unless otherwise specified fuses and/or circuit breakers are mounted from left to right, starting with the highest capacity and working to the lowest capacity.

125 A, 150 A, 175 A, and 200 A circuit breakers occupy two mounting positions.

225 A, 250 A, and 300 A circuit breakers occupy three mounting positions.

Caution: *A 100 A circuit breaker or fuse SHALL HAVE an empty mounting position between it and any other overcurrent protective device. A 175 A or greater circuit breaker SHALL HAVE an empty mounting position between it and any other overcurrent protective device.*

Maximum lug width, 0.625 inches.

Ordering Notes

- 1) Order circuit breakers as required per Table 11 or Table 12.
- 2) Order fuses as required per Table 13. Also order one (1) P/N 117201 bullet nose type fuseholder per fuse ordered. Order replacement alarm fuses (18/100 A) per Table 18.
- 3) Order load lugs (two hole, 1/4" bolt clearance hole, 5/8" centers) as required for each distribution position per Table 22.
- 4) Order lug hardware kit (P/N 541084) as required. Lug hardware kit provides thirty-two (32) sets of 1/4-20 hardware (nuts, flat washers, and lock washers), enough for sixteen (16) lug landing points.

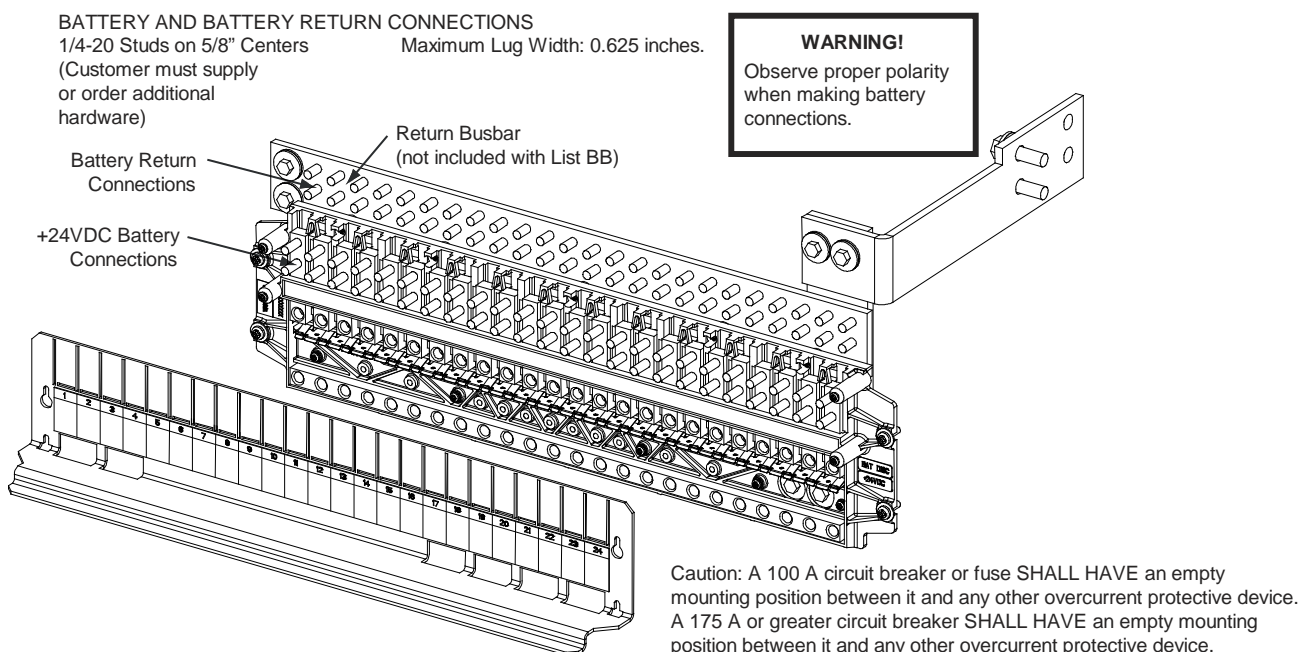

Vertiv™ NetSure™ 710NPBA DC Power System

System Application Guide

List BC: Battery Disconnect Distribution Panel (with Return Busbar) and List BD: Battery Disconnect Distribution Panel (without Return Busbar), (4) GJ/218 Circuit Breaker Battery Disconnect Positions

Features

- ◆ (4) +24 V Battery Disconnect Circuit Breaker Mounting Positions:
100 A to 800 A GJ/218 Type Circuit Breakers.
- ◆ List BC Includes a return busbar; List BD does not include a return busbar.
- ◆ 600 A Maximum Capacity.
Maximum current rating of each landing point is 360 A.

Restrictions

Cannot be used with List 21.

Must be installed in top row only (limit one battery disconnect panel per distribution cabinet).

Maximum lug width, 1.375 inches.

For an 800 A circuit breaker, load must not exceed 600 A.

Ordering Notes

- 1) Order circuit breakers and associated jumper kits as required per Table 15.
- 2) Order load lugs (two hole, 3/8" bolt clearance hole, 1" centers) as required for each distribution position per Table 23.
- 3) Order lug hardware kit (P/N 548184) as required. Lug hardware kit provides sixteen (16) sets of 3/8-16 hardware (bolts, flat washers, and lock washers), enough for eight (8) lug landing points.

BATTERY AND BATTERY RETURN CONNECTIONS

3/8-16 Captive Nuts on 1" Centers

(Customer must supply
or order additional
hardware)

Maximum Lug Width:
1.375 inches.

Return Busbar
(not included
with List BD)

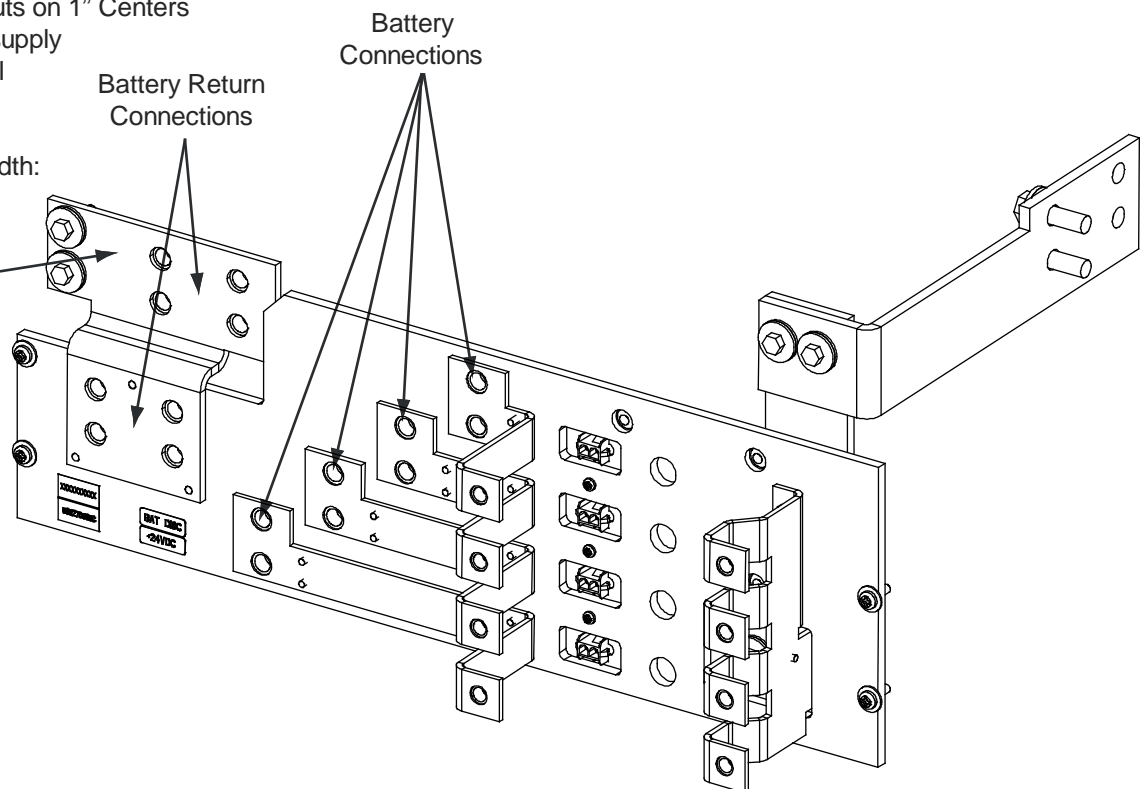

Vertiv™ NetSure™ 710NPBA DC Power System

System Application Guide

List BE: Battery Disconnect Distribution Panel.

(2) TPH Fuse Battery Disconnect Position (without Shunts) (without Return Busbar)

Features

- ◆ (2) +24 V Battery Disconnect Fuse Mounting Positions:
70 A to 600 A TPH Type Fuses.
- ◆ Does NOT include Shunts.
- ◆ Does NOT include a return busbar.
- ◆ 1200 A Maximum Capacity.

Restrictions

Cannot be used with List 21.

Must be installed in top row only (limit one battery disconnect panel per distribution cabinet).

Maximum lug width, 1.88 inches.

Ordering Notes

- 1) Order fuses as required per Table 16. Order replacement alarm fuses (1/4 A) per Table 18.
- 2) Order load lugs (two hole, 3/8" bolt clearance hole, 1" centers) as required for each distribution position per Table 23.
- 3) Order lug hardware kit (P/N 548184) as required. Lug hardware kit provides sixteen (16) sets of 3/8-16 hardware (bolts, flat washers, and lock washers), enough for eight (8) lug landing points.

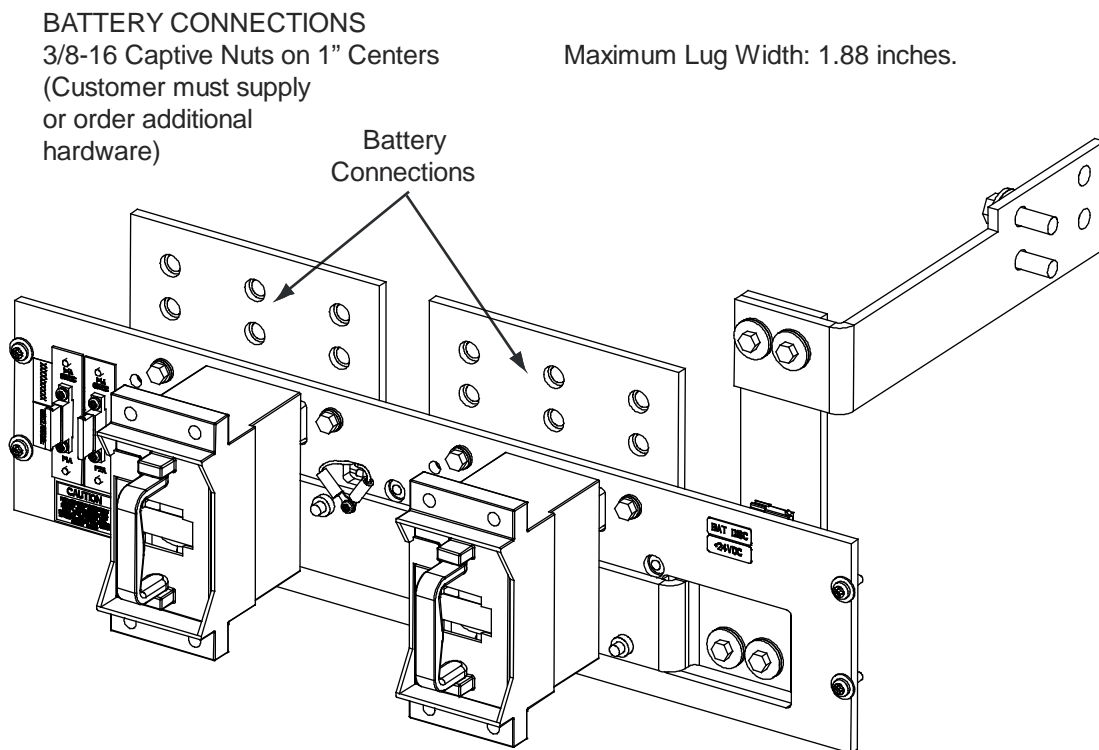

Vertiv™ NetSure™ 710NPBA DC Power System

System Application Guide

List BF: Battery Disconnect Distribution Panel,

(2) TPH Fuse Battery Disconnect Positions (with Shunts) (without Return Busbar)

Features

- ◆ (2) +24 V Battery Disconnect Fuse Mounting Positions:
70 A to 600 A TPH Type Fuses.
- ◆ Includes Shunts, 800 A / 25 mV. Each shunt is equipped with 10' jumpers for connection to monitoring device. If the system is equipped with an SM-DU+, the leads are trimmed and connected to the SM-DU+ (internal to the distribution cabinet).
- ◆ Does NOT include a return busbar.
- ◆ 1200 A Maximum Capacity.

Restrictions

Cannot be used with List 21.

Must be installed in top row only (limit one battery disconnect panel per distribution cabinet).

Maximum lug width, 1.88 inches.

Ordering Notes

- 1) Order fuses as required per Table 16. Order replacement alarm fuses (1/4 A) per Table 18.
- 2) Order load lugs (two hole, 3/8" bolt clearance hole, 1" centers) as required for each distribution position per Table 23.
- 3) Order lug hardware kit (P/N 548184) as required. Lug hardware kit provides sixteen (16) sets of 3/8-16 hardware (bolts, flat washers, and lock washers), enough for eight (8) lug landing points.

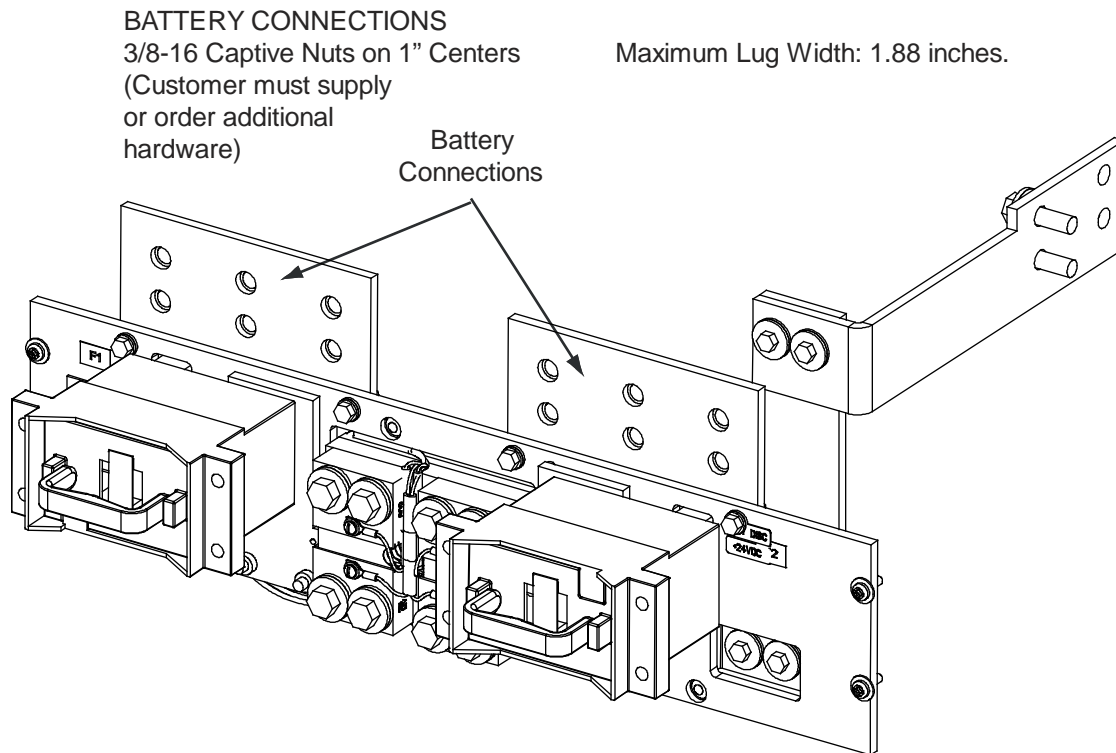

Vertiv™ NetSure™ 710NPBA DC Power System

System Application Guide

List BG: Battery Disconnect Distribution Panel, (4) TPH Fuse Battery Disconnect Positions (without Shunts) (without Return Busbar)

Features

- ◆ (4) +24 V Battery Disconnect Fuse Mounting Positions:
70 A to 400 A TPH Type Fuses.
- ◆ Does NOT include Shunts.
- ◆ Does NOT include a return busbar.
- ◆ 1200 A Maximum Capacity.

Restrictions

Cannot be used with List 21.

Must be installed in top row only (limit one battery disconnect panel per distribution cabinet).

Maximum lug width, 1.75 inches.

Ordering Notes

- 1) Order fuses as required per Table 16. Order replacement alarm fuses (1/4 A) per Table 18.
- 2) Order load lugs (two hole, 3/8" bolt clearance hole, 1" centers) as required for each distribution position per Table 23.
- 3) Order lug hardware kit (P/N 548184) as required. Lug hardware kit provides sixteen (16) sets of 3/8-16 hardware (bolts, flat washers, and lock washers), enough for eight (8) lug landing points.

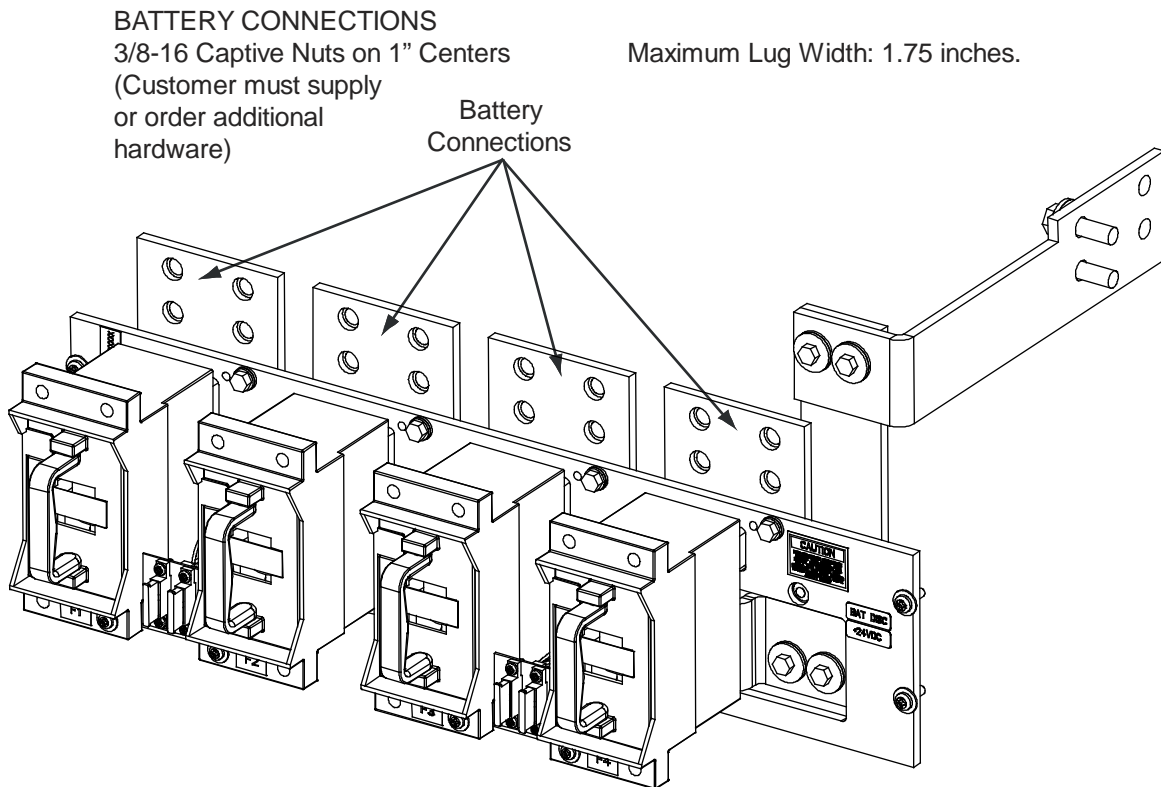

Vertiv™ NetSure™ 710NPBA DC Power System

System Application Guide

List BH: Battery Disconnect Distribution Panel, (4) TPH Fuse Battery Disconnect Positions (with Shunts) (without Return Busbar)

Features

- ◆ (4) +24 V Battery Disconnect Fuse Mounting Positions:
70 A to 400 A TPH Type Fuses.
- ◆ Includes Shunts, 600 A / 25 mV. Each shunt is equipped with 10' jumpers for connection to monitoring device. If the system is equipped with an SM-DU+, the leads are trimmed and connected to the SM-DU+ (internal to the distribution cabinet).
- ◆ Does NOT include a return busbar.
- ◆ 1200 A Maximum Capacity.

Restrictions

Cannot be used with List 21.

Must be installed in top row only (limit one battery disconnect panel per distribution cabinet).

Maximum lug width, 1.75 inches.

Ordering Notes

- 1) Order fuses as required per Table 16. Order replacement alarm fuses (1/4 A) per Table 18.
- 2) Order load lugs (two hole, 3/8" bolt clearance hole, 1" centers) as required for each distribution position per Table 23.
- 3) Order lug hardware kit (P/N 548184) as required. Lug hardware kit provides sixteen (16) sets of 3/8-16 hardware (bolts, flat washers, and lock washers), enough for eight (8) lug landing points.

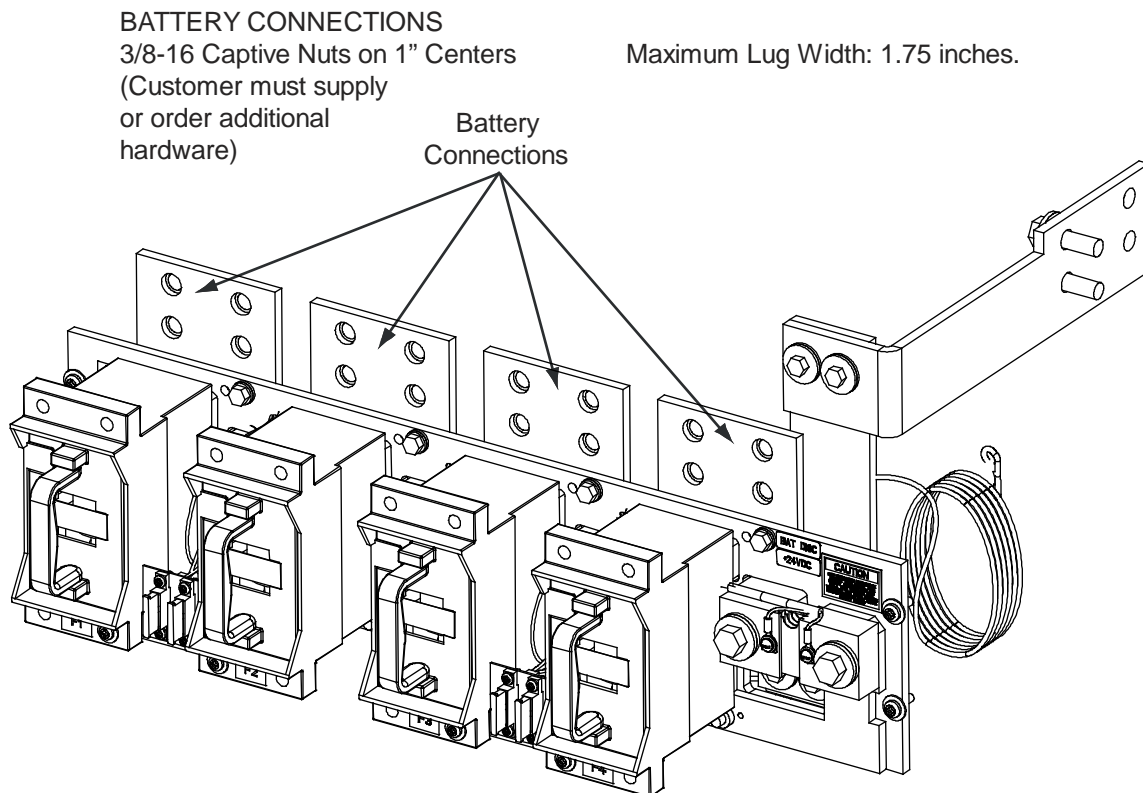

Return Bar Panel

List GA: Return Bar Panel

Features

- ◆ Return bar panel for use with distribution panels when internal load returns are required.
- ◆ 1200 A Maximum Capacity.

Restrictions

Cannot be used in a 1- row distribution cabinet.
Can be installed in any row 1-4 of a 2-, 3-, or 4-row distribution cabinet.
Maximum lug width, 1.38 inches.

Ordering Notes

- 1) Specify row for panel location(s).
- 2) To terminate load and/or battery returns within the distribution cabinet, order List GA as required.
- 3) Order lug hardware kit (P/N 548184) as required. Lug hardware kit provides sixteen (16) sets of 3/8-16 hardware (bolts, flat washers, and lock washers), enough for eight (8) lug landing points.

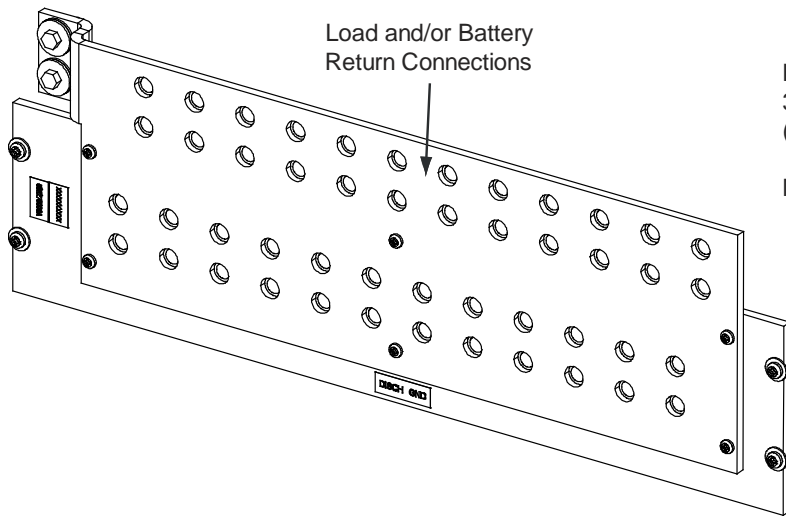

LOAD AND/OR BATTERY RETURN CONNECTIONS
3/8-16 Captive Nuts on 1" Centers
(Customer must supply or order additional hardware)

Maximum Lug Width: 1.38 inches.

Bulk Output Panel

List EA: Bulk Output Panel

Features

- ◆ Provides a bulk output panel with five (5) landing points per polarity.
- ◆ 1600 A Maximum Capacity.

Restrictions

Not available with List 21 (1-row cabinet).

Not available with List LL in same row.

Maximum lug width, 2.0 inches.

Ordering Notes

- 1) Order as required.
- 2) Specify row for panel location(s).
- 3) When replacing a List AA, AB, AC, AD, AE, AF, AG, AH, AJ, AK, DA, DB, DC, DD, BA, BB, BC, BD, BE, BF, BG, or BH with this panel; order busbars per Table 6. Existing busbars required to be replaced with these busbars.

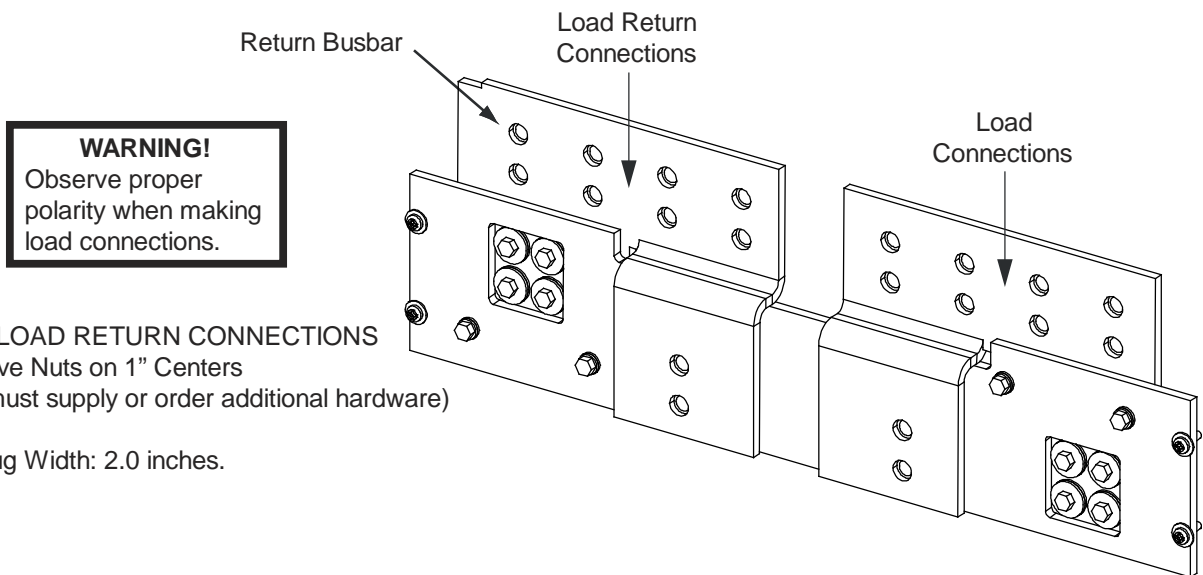

WARNING!
Observe proper polarity when making load connections.

LOAD AND LOAD RETURN CONNECTIONS
3/8-16 Captive Nuts on 1" Centers
(Customer must supply or order additional hardware)

Maximum Lug Width: 2.0 inches.

Vertiv™ NetSure™ 710NPBA DC Power System
System Application Guide

When replacing a List AA, AB, AC, AD, AE, AF, AG, AH, AJ, AK, DA, DB, DC, DD, BA, BB, BC, BD, BE, BF, BG, or BH with List EA, remove one (1) hot side and one (1) return side busbar from corresponding position and replace with new busbars ordered from Table 6.

4-Row Distribution Cabinet without LVLD					
Existing Busbar			New Busbar		
Row	Return Side	Hot Side	Row	Return Side	Hot Side
4	548274	561774	4	562469	562473
3	548273	561773	3	562470	562474
2	548272	561772	2	562471	562475
1	548271	562822	1	562472	562476
3-Row Distribution Cabinet without LVLD					
Existing Busbar			New Busbar		
Row	Return Side	Hot Side	Row	Return Side	Hot Side
3	548274	561774	3	562469	562473
2	548272	561881	2	562477	562452
1	548271	562822	1	562472	562476
2-Row Distribution Cabinet without LVLD					
Existing Busbar			New Busbar		
Row	Return Side	Hot Side	Row	Return Side	Hot Side
2	548273	561773	2	562470	562474
1	548271	562822	1	562472	562476

Table 6

Battery Disconnect Contactors

List CA: 600 A Battery Disconnect Contactor

Features

- ◆ Provides a battery disconnect contactor which is mounted within the distribution cabinet.

Restrictions

Must be used with List LB, MB, or both.

For use with List 21 only.

Can only use LVLD or LVBD on List 21, not both.

Ordering Notes

- 1) Order as required.

List CB: 1200 A Battery Disconnect Contactor

Features

- ◆ Provides a battery disconnect contactor which is mounted within the distribution cabinet.

Restrictions

Must be used with List LB, MB, or both.

For use with List 22, 23, or 24 only.

If used in List 23 or 24, system capacity is reduced to 1200 A.

Ordering Notes

- 1) Order as required.

List CC: 2000 A Battery Disconnect Contactor

Features

- ◆ Provides a battery disconnect contactor which is mounted within the distribution cabinet.

Restrictions

Must be used with List LB, MB, or both.

For use with List 22, 23, or 24 only.

Ordering Notes

- 1) Order as required.

Low Voltage Disconnect Options

List LB: Low Voltage Battery Disconnect (LVBD)

Features

- ◆ Adds Low Voltage Battery Disconnect (LVBD) to the system.
- ◆ Adds LVD Driver circuit card P/N 540972 or LVD Driver Lite circuit card P/N 547873 to the system.

Restrictions

Must be used with List CA, CB, or CC.

Ordering Notes

- 1) Order if low voltage battery disconnect (LVBD) is required.
- 2) Can be combined with manual battery disconnect (List MB) if required.

List LL: Low Voltage Load Disconnect (LVLD)

Features

- ◆ Adds low voltage load disconnect (LVLD) to a distribution panel.
- ◆ Adds LVD Driver circuit card P/N 540972 or LVD Driver Lite circuit card P/N 547873 to the system, one per system.

Restrictions

Must be used with List AA through AL, AN, DA through DJ. Not available with Lists AM, AP, DK or EA.

In List 22, List 23, List 24, the List LL Low Voltage Load Disconnect (LVLD) option cannot be installed in the field for systems that are not equipped with any LVLDs from the factory. Field replacement of factory-installed LVLD contactors is still available.

Cannot use List LL in row 1 if row 1 is equipped with List DJ.

Capacity is reduced to 500 amps for any row equipped with List LL.

Ordering Notes

- 1) Order low voltage load disconnect (LVLD) per load distribution panel (one per row) as required. Specify by row.

Manual Battery Disconnect Option

List MB: Manual Battery Disconnect

Features

- ◆ Adds manual battery disconnect to the system.
- ◆ Adds manual disconnect circuit card P/N 540973 to the system.

Restrictions

Must be used with List CA, CB, or CC.

If this option is to be used as a Maintenance Battery Disconnect only, at least one rectifier requires to be active and providing voltage to the system for proper operation.

Ordering Notes

- 1) Order if manual battery disconnect is required.
- 2) Can be combined with low voltage battery disconnect (List LB) if required.

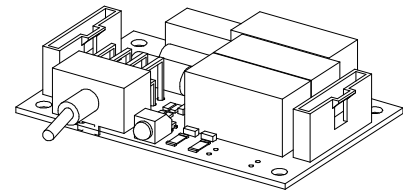

ACCESSORY DESCRIPTIONS

Controller

NCU (NetSure™ Control Unit) Controller, P/N 1M830DNA

Features

- ◆ Provides one (1) Model M830DNA, Spec. No. 1M830DNA system controller.
- ◆ Factory programmed with the configuration file required for the system configuration ordered.

Note: For custom NCU configurations, contact Vertiv.

Restrictions

Only one (1) controller per power system is required.

Ordering Notes

- 1) Order one (1) controller (P/N 1M830DNA or 1M820DNA) per power system.
- 2) If the NCU Controller (1M830DNA) is ordered, order a “2nd Ethernet Port Add-On Kit” P/N [559252](#) if required. For retrofitting into older bays, order “2nd Ethernet Port Retrofit Kit” P/N [559251](#).
- 3) Order the optional EIB controller extended interface board as required (see page 54).
- 4) Order optional [SM-DU+ Shunt Monitoring](#) (P/N 548078) for any fuse panel with shunts (Lists AF, AH, AK, BF, or BH) or any GJ/218 panels (Lists AC, AD, BC, BD, AM, or AP) that are equipped with shunted breakers. (The SM-DU+ is factory-wired to the shunts.)
- 5) Order up to six (6) optional [temperature probes](#) for ambient and battery temperature monitoring, as required. The temperature probe(s) may also be used for the battery charge temperature compensation feature and the BTRM (Battery Thermal Runway Management) feature. Refer to “[Optional Temperature Probes](#)” for additional information.
- 6) Order optional supervisory modules as desired (shipped loose).
 - [SM-TEMP](#) (Supervisory Module for Temperature Probes).
- 7) Ordering an NCU for replacing an NCU or as a spare NCU.

Note: A system can have up to (8) SM-Temp modules for a total of sixty-eight (68) temperature probes that can be used in the power system for ambient and battery monitoring.

If the NCU is to be used as a replacement in a specific system, it should be ordered with the same configuration file as the original NCU controller. This is identified by a six digit number. If the controller part number ends with a six digit number, for example, 1M830BNA559242, the configuration file number is the last six characters. If the part number does not have these characters, the configuration file number can be found on the controller nameplate – “Programmed with Configuration File #####”. The controller may also have a Unique Identification Number (UIN). This number indicates that certain parameters were set at the factory to match the controller to the options selected with the power plant (such as low voltage disconnect, load and battery shunt ratings, etc.). If the controller has a UIN, the plant will have shipped with a USB drive labelled with the UIN. The UIN label may also be located near the controller slot in the system. If the controller has a UIN, provide this UIN number, along with the configuration number, when ordering so that the new controller will match that of the original controller shipped with the system. The user manual provided with the controller provides instructions for replacing and programming the controller. It is important to follow these instructions carefully. The user manual also provides instructions for saving certain controller files that are created when changes are made to the system after leaving the factory. These files can be programmed into the replacement controller so it can match the latest saved state of the original controller.

If the NCU is being ordered as a spare part for any of a group of power plants, the same procedure can be followed. If the replacement controller’s configuration does not match that of the original controller, the original files can be retrieved from the USB drive shipped with the plant, if available. If the USB drive is not available, contact the factory or technical assistance center to obtain a copy of the original configuration file (all package) so it can be programmed into the new controller.

The NCU programming files are unique to the NCU. Files from an SCU+ or ACU+ are not compatible with the NCU and MUST NOT BE loaded into an NCU.

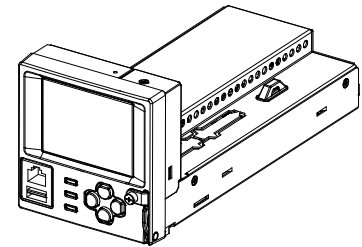

Vertiv™ NetSure™ 710NPBA DC Power System

System Application Guide

ACU+ (Advanced Control Unit Plus) Controller, P/N 1M820DNA

Features

- ◆ Provides one (1) Model M820DNA, Spec. No. 1M820DNA system controller.
- ◆ Factory programmed with the configuration file required for the system configuration ordered.

Note: For custom ACU+ configurations, contact Vertiv.

Restrictions

Only one (1) controller per power system is required.

Ordering Notes

- 1) Order one (1) controller (P/N 1M820DNA or 1M830DNA) per power system.
- 2) Order the optional EIB controller extended interface board as required (see page 54).
- 3) Order optional [SM-DU+ Shunt Monitoring](#) (P/N 548078) for any fuse panel with shunts (Lists AF, AH, AK, BF, or BH) or any GJ/218 panels (Lists AC, AD, BC, BD, AM, or AP) that are equipped with shunted breakers. (The SM-DU+ is factory-wired to the shunts.)
- 4) Order up to six (6) optional [temperature probes](#) for ambient and battery temperature monitoring, as required. The temperature probe(s) may also be used for the battery charge temperature compensation feature and the BTRM (Battery Thermal Runway Management) feature. Refer to "[Optional Temperature Probes](#)" for additional information.
- 5) Order optional supervisory modules as desired (shipped loose).
 - [SM-TEMP](#) (Supervisory Module for Temperature Probes).

Note: A system can have up to (8) SM-Temp modules for a total of sixty-eight (68) temperature probes that can be used in the power system for ambient and battery monitoring.

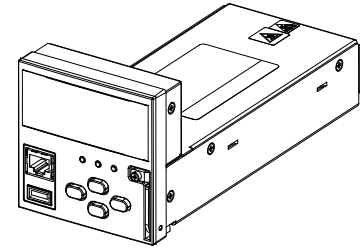

NCU Controller 2nd Ethernet Port Kits



NOTE! IB5 boards with a 10M/100M/1G Ethernet port replaced IB4 boards with a 10M/100M Ethernet port. This transition enables the support of connected devices that communicate up to 1G. While both boards are physically interchangeable, the IB5 board does require the NCU to have V1.2.80 or higher software loaded.

NCU Controller 2nd Ethernet Port Add-On Kit, P/N 559252

Features

- ◆ Provides the IB5 board with a second Ethernet port. The Ethernet port located on the NCU Controller's front panel can be used to connect a computer directly to the NCU. The Ethernet port located on the IB5 board can be used to connect the NCU to your Local Area Network (LAN).

Restrictions

For use only with NCU controller, not the ACU+ controller. Factory installed in a main bay if initially ordered with the power system. Field installable only into a main bay if initially ordered with the NCU controller.

Ordering Notes

- 1) If a second Ethernet port is required, order kit P/N 559252. For field upgrade of systems originally configured with the ACU+ controller, order kit P/N 559251. The field upgrade must also include the NCU controller replacing the ACU+ controller.

NCU Controller 2nd Ethernet Port Retrofit Kit, P/N 559251

Features

- ◆ Provides a complete control module assembly that allows an IB5 board to be connected to the NCU in an older main bay.
- ◆ Provides the IB5 board with a second Ethernet port. The Ethernet port located on the NCU Controller's front panel can be used to connect a computer directly to the NCU. The Ethernet port located on the IB5 board can be used to connect the NCU to your Local Area Network (LAN).

Restrictions

Field installable only into a main bay if initially ordered with the ACU+ controller. The field upgrade must also include the NCU controller replacing the ACU+ controller.

Ordering Notes

- 1) For field upgrade of systems originally configured with the ACU+ controller, order kit P/N 559251. The field upgrade must also include the NCU controller replacing the ACU+ controller.

Optional EIB (Controller Extended Interface Board), P/N 548120

Features

- ◆ Provides connections for up to two (2) temperature probes.
- ◆ Provides connections for the five (5) programmable form C- relay outputs located on the board.
- ◆ Provides connections for the three (3) shunt inputs located on the board.
- ◆ Provides connections for the eight (8) battery midpoint inputs located on the board.

Note: An IB2 (Controller Interface Board) is factory provided with the system. The IB2 provides eight (8) programmable form C- relay outputs, eight (8) programmable binary inputs, and two (2) temperature inputs.

Restrictions

Only one (1) EIB per power system.

Ordering Notes

- 1) Order by P/N 548120 as required. Also order up to two (2) additional temperature probes, as desired. See “[Optional Temperature Probes](#)”.
- 2) Refer to “In-Line Fuse and Resistor Pigtail Kits” on page 55 for in-line resistor pigtailed for use with shunt inputs and in-line fuse pigtailed for use with battery midpoint inputs.

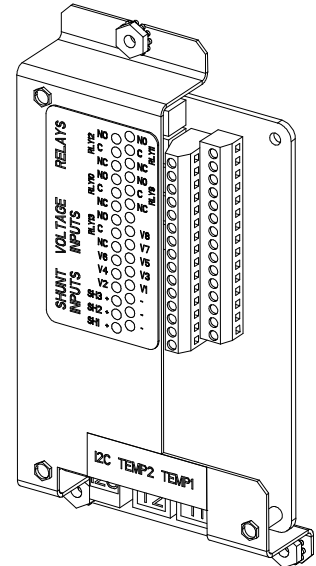

Optional SM-DU+ Shunt Monitoring, P/N 548078

Features

- ◆ Provides twenty-five (25) shunt monitoring inputs.

Ordering Notes

- 1) Order optional SM-DU+ Shunt Monitoring for any fuse panel with shunts (Lists AF, AH, AK, BF, or BH) or any GJ/218 panels (Lists AC, AD, BC, BD, AM, or AP) that are equipped with shunted breakers. (The SM-DU+ is factory-wired to the shunts.) Order by P/N 548078 as required.
- 2) Refer to “In-Line Fuse and Resistor Pigtail Kits” on page 55 for in-line resistor pigtailed for use with shunt inputs.

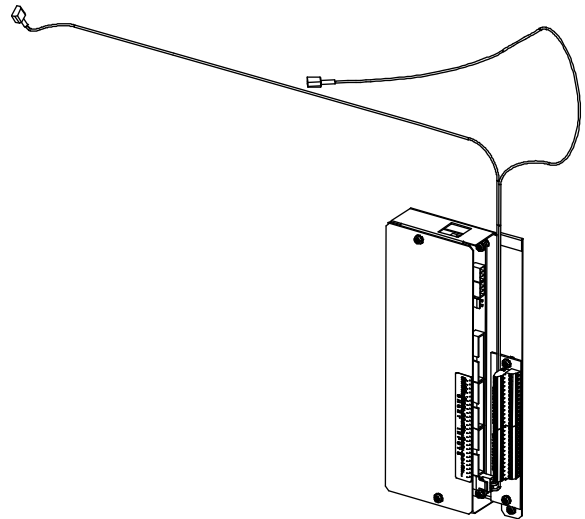

In-Line Fuse and Resistor Pigtail Kits

In-line fuse kits should be used for connecting to battery or bus potentials for use with the digital inputs on the IB2 Interface Board and the battery midpoint/block voltage inputs on the EIB Extended Interface Board. In-line resistor kits should be used for connecting to shunts for use with the EIB Extended Interface Board and SMDU+ Shunt Interface Board.

1 A In-Line Fuse Pigtail Kit, P/N 431300200

Features

- ◆ In-line fuse pigtail kit with 3/8" ring lug.

Ordering Notes

- 1) Order Kit P/N 431300200, as required.

1 A In-Line Fuse Pigtail Kit, P/N 431300300

Features

- ◆ In-line fuse pigtail kit with 5/16" ring lug.

Ordering Notes

- 1) Order Kit P/N 431300300, as required.

1 A In-Line Fuse Pigtail Kit, P/N 535135

Features

- ◆ In-line fuse pigtail kit with a splice connector, 3/8" ring lug, and 1/4" ring lug.

Ordering Notes

- 1) Order Kit P/N 535135, as required.

49.9 Ohm In-Line Resistor Pigtail Kit, P/N 424227900

Features

- ◆ In-line resistor pigtail kit with 3/8" ring lug.

Ordering Notes

- 1) Order Kit P/N 424227900, as required.

49.9 Ohm In-Line Resistor Pigtail Kit, P/N 424228000

Features

- ◆ In-line resistor pigtail kit with a splice connector.

Ordering Notes

- 1) Order Kit P/N 424228000, as required.

49.9 Ohm In-Line Resistor Pigtail Kit, P/N 424228100

Features

- ◆ In-line resistor pigtail kit with 5/16" ring lug.

Ordering Notes

- 1) Order Kit P/N 424228100, as required.

Optional Temperature Probes

Features

- ◆ Up to two (2) temperature probes can be connected to the IB2 (Controller Interface Board). Up to two (2) additional temperature probes can be connected to the optional EIB (Controller Extended Interface Board). Any combination of the four (4) temperature probes can be programmed to monitor ambient temperature and/or battery temperature. A temperature probe set to monitor battery temperature can also be used for the rectifier battery charge temperature compensation feature, or the battery charge temperature compensation feature can be programmed to use the average or highest value of all battery temperature probes. The battery charge temperature compensation feature allows the controller to automatically increase or decrease the output voltage of the system to maintain battery float current as battery temperature decreases or increases, respectively. Battery life can be extended when an optimum charge voltage to the battery with respect to temperature is maintained. A temperature probe set to monitor battery temperature can also be used for the BTRM (Battery Thermal Runaway Management) feature. The BTRM feature lowers output voltage when a high temperature condition exists to control against battery thermal runaway.
- ◆ The temperature sensor end of the probe contains a tab with a 5/16" clearance hole for mounting.
- ◆ Temperature probes can also be used with the optional [SM-Temp Temperature Concentrator](#).

Restrictions

A temperature probe programmed to monitor battery temperature should be mounted on the negative post of a battery cell to sense battery temperature. A temperature probe used for battery charge temperature compensation or BTRM (Battery Thermal Runaway Management) should also be mounted on the negative post of a battery cell. A temperature probe programmed to monitor ambient temperature should be mounted in a convenient location, away from direct sources of heat or cold.

Ordering Notes

- 1) Order temperature probes as required. Note that each temperature probe consists of two or three pieces which plug together to make a complete probe (see the following illustration). For a complete temperature probe, order one (1) P/N 552992 (10.3 meters) or one (1) P/N 556155 (3.3 meters). If additional length is required, order temperature probe extension cable P/N 04119122 (10 meters).
- 2) If more probes are desired, order one or more SM-Temp Temperature Concentrator, P/N 547490. See [SM-Temp Temperature Concentrator](#).

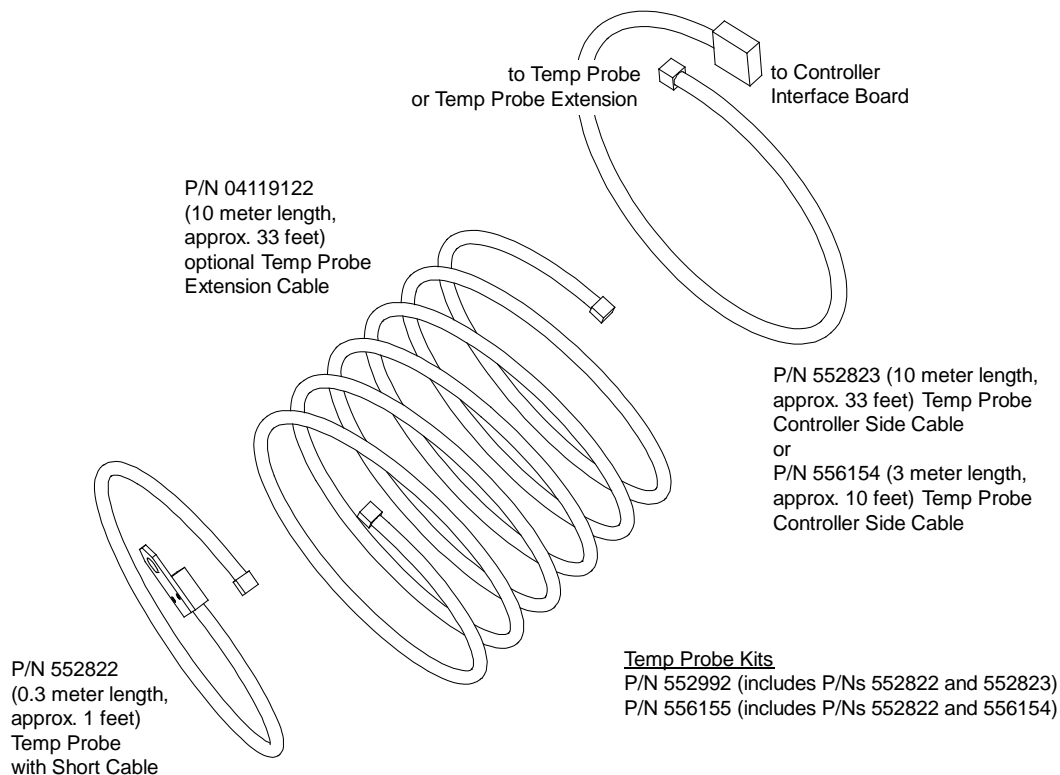

Optional SM-Temp Temperature Concentrator, P/N 547490

Features

- ◆ Allows for multiple temperature probes to be used for ambient temperature monitoring, battery temperature monitoring, temperature compensation, and/or BTRM (Battery Thermal Runaway Management).
- ◆ Provides (8) temperature probe inputs per SM-Temp.
- ◆ Can cascade up to eight (8) SM-Temp modules, connecting up to sixty-four (64) temperature probes.
- ◆ The SM-Temp Concentrator is connected at the end of the controller's CAN Bus. Via the CAN Bus, the controller reads each temperature probe from each SM-Temp Concentrator.
- ◆ Refer to the SM-Temp Temperature Concentrator Instructions (UM547490) for more information.

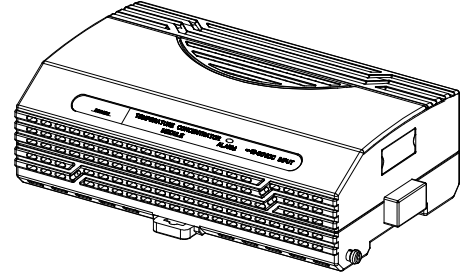

Restrictions

Requires ACU+ version 3.02 or later when SM-Temp is connected into the ACU+ CAN Bus.

Ordering Notes

- 1) Order SM-Temp Temperature Concentrator, P/N 547490, as required.
- 2) Order up to (8) temperature probes for each concentrator. See [“Optional Temperature Probe”](#) above.
- 3) Order one (1) SM-Temp CAN Bus Interface Cable, P/N 562868, to connect the SM-Temp into the controller's CAN bus.
- 4) Order SM-Temp jumpers (P/N 552888) to interconnect SM-Temp units, as required. See “SM-Temp Jumpers, P/N 552888” on page 57.

SM-Temp Jumpers, P/N 552888

Features

- ◆ Provides 20' of 18 AWG solid red / black twisted pair cable and three (3) wire splices for connecting the CAN bus of multiple SM-Temp modules together.

Ordering Notes

- 1) Order P/N 552888 as required.

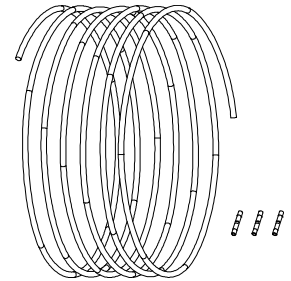

Rectifier Module, P/N 1R243000

Features

- ◆ Provides one (1) Model R24-3000, Spec. No. 1R243000, 3000 watt / 24 volt rectifier module.
- ◆ Refer to the rectifier instruction document (UM1R243000) for more information.

Restrictions

For use in Spec. No. 588705200, 588705201, 588705202, 588705203, or 588705204 module mounting assemblies.

Ordering Notes

- 1) Order by P/N 1R243000 as required.

Note: 58870520101 (8-position shelf).
58870520201 (16-position shelf).
58870520301 (24-position shelf).
58870520401 (32-position shelf).
58870520001 (8-position expansion shelf).

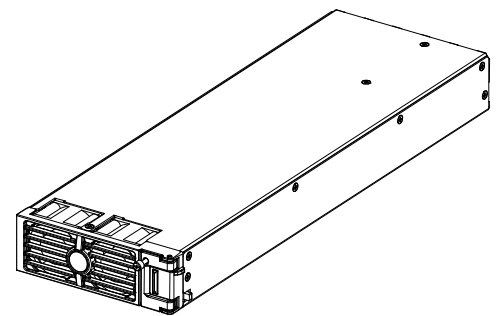

Rectifier Module, P/N 1R242500

Features

- ◆ Provides one (1) Model R24-2500, Spec. No. 1R242500, 2500 watt / 24 volt rectifier module.
- ◆ Refer to the rectifier instruction document (UM1R243000) for more information.

Restrictions

For use in Spec. No. 588705200, 588705201, 588705202, 588705203, or 588705204 module mounting assemblies.

Ordering Notes

- 1) Order by P/N 1R242500 as required.

Note: 58870520101 (8-position shelf).
58870520201 (16-position shelf).
58870520301 (24-position shelf).
58870520401 (32-position shelf).
58870520001 (8-position expansion shelf).

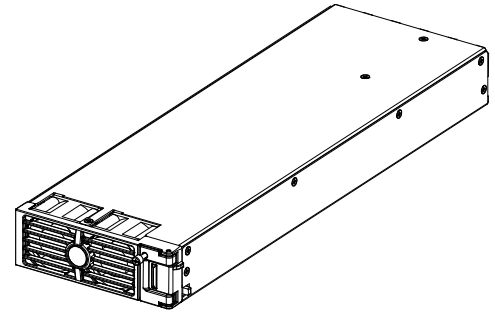

DC-DC Converter Module, P/N 1C24481500

Features

- ◆ Provides one (1) Model C24/48-1500, Spec. No. 1C24481500, 1500 watt / 24 to 48 volt DC-DC converter module.
- ◆ Refer to the converter instruction document (UM1C24481500) for more information.

Restrictions

For use in Spec. No. 588705200, 588705201, 588705202, 588705203, or 588705204 module mounting assemblies.

Requires [List 60](#).

Ordering Notes

- 1) Order by P/N 1C24481500 as required. Each 8-position module mounting shelf in a module mounting assembly holds up to four (4) DC-DC converter modules when equipped with a DC-DC Converter Kit (List 60).

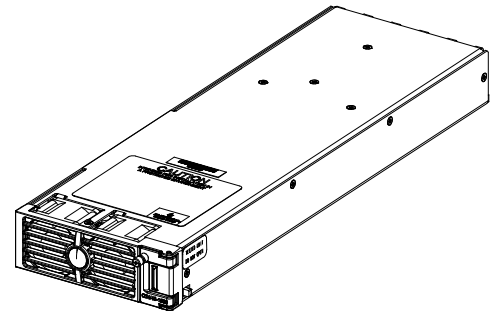

Module Mounting Position Blank Cover Panel, P/N 540959

Features

- ◆ Covers one (1) unused module mounting position.

Restrictions

For use in Spec. No. 588705200, 588705201, 588705202, 588705203, or 588705204 module mounting assemblies.

Ordering Notes

- 1) Order by P/N 540959 as required. Order a module mounting position blank cover panel for each empty module mounting position in the system, as desired.

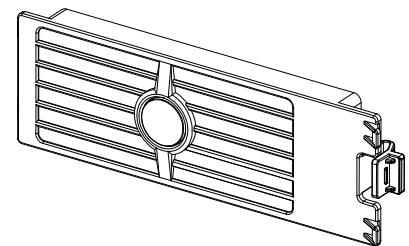

Optional eSure™ Power Extend Converter

Features

- ◆ The eSure Power Extend Converter (Model C48/58-1000B, Spec. No. 1C48581000B) is a compact DC/DC converter unit which offers efficient power conversion. It operates from a nominal -48 VDC source to provide regulated -58 VDC to the load for continuous operation to end of battery discharge. Refer to UM565050 and IM565391 for further information.

Restrictions

Only install the power extend converter into a -48 VDC distribution position. Non-repairable damage will occur if the power extend converter is plugged into a +24 VDC distribution position.

Ordering Notes

- 1) To add an eSure Power Extend Converter to a 581127000 List DE, DF, DG, DH, DJ, DK (26-position bullet dual voltage) distribution panel or 581127000 List DA, DB, DC, DD (21-position bullet dual voltage) distribution panel; refer to the material list in the eSure Power Extend Converter Calculator (link provided below).

<https://www.vertiv.com/en-us/products-catalog/critical-power/dc-power-systems/esure-power-extend-converter-c4858-1000/#/downloads>

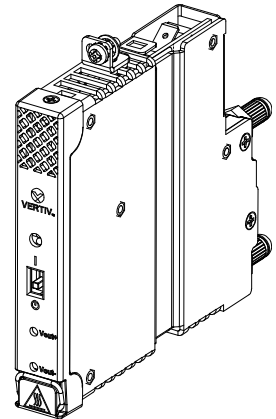

Relay Racks and Shipping Brackets

Note: System components are factory mounted in a relay rack or on shipping rails as specified when ordered.

Features

- ◆ The system can be factory mounted to a relay rack or on shipping brackets as specified when ordered.
- ◆ Relay racks (except P/N 562353 and P/N 10009902) are 23" standard mounting with 3" deep uprights. P/N 562353 and P/N 10009902 are 23" standard mounting with 6" deep upright.
- ◆ When ordered with shipping brackets, the system is mounted on shipping brackets bolted to a shipping skid. The shipping brackets can mount a system up to 22U high.

Ordering Notes

- 1) Order from relay racks and shipping brackets listed in Table 7.

Part Number	Size	Available Mounting Positions (1RU = 1-3/4")	Notes
509638 509639	Shipping Brackets	22RU	--
562360	43.156"H x 24.376"W x 15"D	23RU	Seismic (Note 1)
559817	51.906"H x 24.376"W x 15"D	28RU	Welded
564169	60.000"H x 25.800"W x 18"D	31RU	Seismic (Note 1)
559818	72.000"H x 24.375"W x 15"D	38RU	Welded
564127	72.000"H x 25.800"W x 18"D	38RU	Seismic (Note 1)
559820	84.000"H x 24.375"W x 15"D	45RU	Welded
562353	84.000"H x 25.800"W x 18"D	45RU	Seismic (Note 1)
10009902	84.000"H x 25.800"W x 18"D	45RU	Seismic (Note 2)
562355	85.750"H x 24.375"W x 15"D	46RU	Welded
559821	90.000"H x 24.375"W x 15"D	48RU	Welded
559822	96.000"H x 24.375"W x 15"D	51RU	Welded

Note 1: Complies with Bellcore Seismic Zone 4 requirements.

Note 2: Complies with Bellcore Seismic Zone 4 requirements, per FEA Analysis.

Table 7
Available Relay Racks and Shipping Brackets

Transition Plates to Mount Relay Rack on Top of GNB Absolyte IIP Batteries

Features

- ◆ Transition Plate Kits can be ordered to mount relay rack P/Ns 543151, 543152, 543153, 543154, 543155, or 543156 on top of GNB Absolyte IIP batteries.
- ◆ Each kit consists of two transition plates with three hole patterns and hardware (3/8") to mount the plates to the above listed relay racks. Customer must supply hardware to mount the transition plates to the battery.

Restrictions

Used with relay rack P/Ns 543151, 543152, 543153, 543154, 543155, or 543156 only.

Ordering Notes

- 1) Order P/N 509819 for a Transition Plate Kit to mount relay rack on top of a GNB 3-100A19, GNB 3-100A27, or GNB 3-100A33 battery.
- 2) Order P/N 514596 for a Transition Plate Kit to mount relay rack on top of a GNB 6-90A09 battery.
- 3) Order P/N 514880 for a Transition Plate Kit to mount relay rack on top of a GNB 3-100A21, GNB 3-100A25, or GNB 3-100A31 battery.

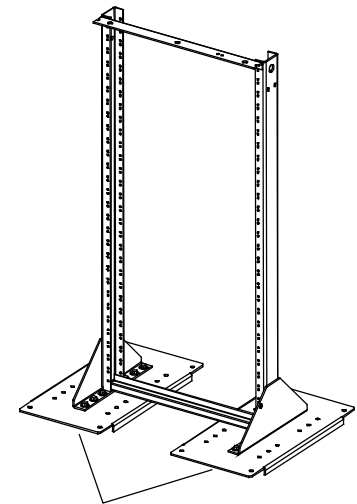

Transition
Plates

Relay Rack Isolation Kit

Features

- ◆ Provides electrical isolation of the relay rack from the concrete floor. Includes an insulating pad, four (4) insulating bushings, and four (4) flat washers to be used with the anchors used to mount the relay rack to the floor.

Ordering Notes

- 1) Order P/N 10019125 for a Relay Rack Isolation Kit to be used with 23" seismic relay racks P/N 562353, PN 10009902, P/N 564127, and P/N 564169.

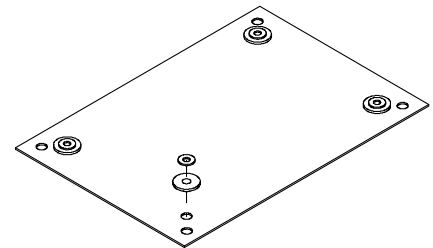

Crimp Lugs

Standard Crimp Lug Tables

Lead Size	Part Number
14 AWG to 10 AWG	245342300
8 AWG	245390200
6 AWG	245346700
4 AWG	245346800
2 AWG	245346900

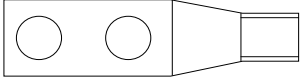

Lugs should be crimped per lug manufacturer's specifications.

Table 8
 Crimp Lug
 Two-Hole, 1/4" Bolt Clearance Hole, 5/8" Centers

Lead Size	Part Number
6 AWG	245349900
4 AWG	245350000
2 AWG	245348200
1/0 AWG	245347100
2/0 AWG	245347200
3/0 AWG	245347300
4/0 AWG	245347400
250 kcmil	245347500
300 kcmil	245347600
350 kcmil	245347700
400 kcmil	245347800
500 kcmil	245347900
600 kcmil	245348000
750 kcmil	245348100

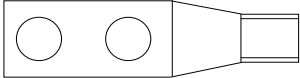

Lugs should be crimped per lug manufacturer's specifications.

Table 9
 Crimp Lug
 Two-Hole, 3/8" Bolt Clearance Hole, 1" Centers

Special Application Crimp Lug / Strap Combination Table

Features

- ◆ Straps two fuseholder/circuit breaker wiring positions together, and provides a crimp-type lug which allows distribution wiring up to 350 kcmil size (maximum size of wire to be connected to a single position is 2 AWG). Designed for use with 125 A and larger bullet nose-type circuit breakers or TPS/TLS-type fuses, which require at least two mounting positions.

Restrictions

If used with bullet nose-type circuit breakers or TPS/TLS-type fuses smaller than 125 A, an empty mounting position is required adjacent to the distribution device.

Ordering Notes

- 1) Specify part number from Table 10 for desired lead size.

Lead Size	Part Number
1/0 AWG	245393500
2/0 AWG	245393600
3/0 AWG	245393700
4/0 AWG	245393800
250 kcmil	514872
350 kcmil	514873

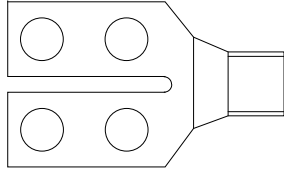

Lugs should be crimped per lug manufacturer’s specifications.

Table 10
Special Application Crimp Lug / Strap Combination
(Two-Hole Lug, 1/4” Bolt Clearance Hole, 5/8” Centers)

Lug Adapters

Busbar for 125 A, 150 A, and 200 A Bullet Nose Type Circuit Breaker, P/N 520989

Features

- ◆ Provides a busbar that mounts on the two lug landing positions of a 125 A, 150 A, or 200 A bullet nose circuit breaker, and allows for use of one standard two-hole lug having 1/4" bolt clearance holes on 5/8" centers.

Ordering Notes

- 1) Order one (1) Part No. 520989 per 125 A, 150 A, and 200 A bullet nose circuit breaker ordered, as desired. See also P/Ns [522786](#) and [534449](#) in this section.

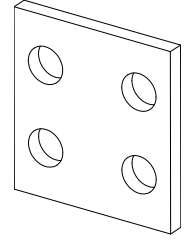

Busbar for 125 A, 150 A, and 200 A Bullet Nose Type Circuit Breaker, P/N 522786

Features

- ◆ Includes one (1) busbar that mounts on the two lug landing positions of a 125 A, 150 A, or 200 A bullet nose circuit breaker, and provides a landing for one standard two-hole lug having 3/8" bolt clearance holes on 1" centers.

Ordering Notes

- 1) Order one (1) Part No. 522786 per 125 A, 150 A, and 200 A bullet nose circuit breaker ordered, as desired. See also P/Ns [520989](#) and [534449](#) in this section.

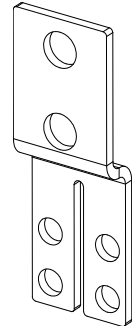

Lug Adapter Busbar Kit for 125 A, 150 A, and 200 A Bullet Nose Type Circuit Breaker, P/N 534449

Features

- ◆ Includes one (1) busbar that mounts on the two lug landing positions of a 125 A, 150 A, or 200 A bullet nose circuit breaker, and provides a landing for one standard two-hole lug having 3/8" bolt clearance holes on 1" centers. Also includes one (1) busbar that mounts on two landings of the associated ground return bar (if furnished), and provides one landing for a standard two-hole lug having 3/8" bolt clearance holes on 1" centers. All busbar and lug mounting hardware is included.

Ordering Notes

- 1) Order one (1) Part No. 534449 per 125 A, 150 A, and 200 A bullet nose circuit breaker ordered, as desired. See also P/Ns [520989](#) and [522786](#) in this section.

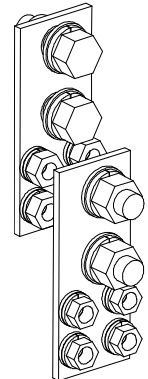

Busbar for 225 A through 300 A Bullet Nose Type Circuit Breaker, P/N 514717

Features

- ◆ Provides a busbar that mounts on the three lug landing positions of a 225 A through 300 A bullet nose circuit breaker, and allows for use of a [Special Application Crimp Lug / Strap Combination](#) lug listed in Table 10.

Ordering Notes

- 1) Order one (1) P/N 514717 per 225 A through 300 A bullet nose circuit breaker ordered, as desired (see also [Lug Adapter Busbar Kit for 225 A through 300 A Bullet Nose Type Circuit Breaker, P/N 514714](#) for another option).

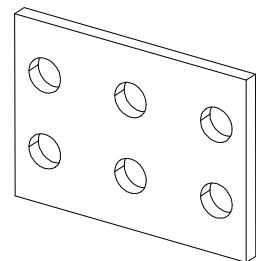

Vertiv™ NetSure™ 710NPBA DC Power System

System Application Guide

Lug Adapter Busbar Kit for 225 A through 300 A Bullet Nose Type Circuit Breaker, P/N 514714

Features

- ◆ Includes one (1) busbar that mounts on the three lug landing positions of a 225 A through 300 A bullet nose circuit breaker, and provides one landing for a standard two-hole lug having 3/8" bolt clearance holes on 1" centers. Also includes one (1) busbar that mounts on three landings of the associated ground return bar (if furnished), and provides one landing for a standard two-hole lug having 3/8" bolt clearance Holes on 1" centers. All busbar and lug mounting hardware is included.

Ordering Notes

- 1) Order one (1) Part No. 514714 per 225 A through 300 A bullet nose circuit breaker ordered, as desired (see also [Busbar for 225 A through 300 A Bullet Nose Type Circuit Breaker, P/N 514717](#) for another option).

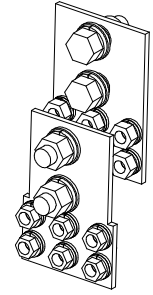

Lug Adapter Busbar Kit for 3-Pole GJ/218 Circuit Breaker Installed in a List AM and List AP Distribution Panel, P/N 562888

Features

- ◆ Includes one (1) busbar that mounts on the three lug landing positions of a three-pole circuit breaker installed in a List AM or List AP distribution panel and one (1) busbar that mounts on the three landings of the associated ground return bar. These busbars provide two (2) landings for standard two-hole lugs having 3/8" bolt clearance holes on 1" centers.

Restrictions

Maximum lug width, 2.0 inches.

Ordering Notes

- 1) Order one (1) Part No. 562888 per three-pole GJ/218 circuit breaker ordered for a List AM or List AP Distribution Panel, as desired.

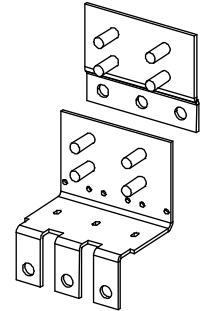

Lug Hardware Kits

1/4-20 Hardware Kit, P/N 541084

Features

- ◆ Lug hardware kit provides thirty-two (32) sets of 1/4-20 hardware for bullet nose distribution panels. Kit includes (32) 1/4-20 Nuts, (32) 1/4" Flat Washers, and (32) 1/4" Lock Washers.

Ordering Notes

- 1) Order Kit P/N 541084, as required.

3/8-16 Hardware Kit, P/N 548184

Features

- ◆ Lug hardware kit provides sixteen (16) sets of 3/8-16 hardware for GJ/218 distribution panels, TPH distribution panels, return bar panels, and battery busbars. Kit includes (16) 3/8-16 x 1-1/4" Bolts, (16) 3/8" Flat Washers, and (16) 3/8" Lock Washers.

Ordering Notes

- 1) Order Kit P/N 548184, as required.

3/8-16 Hardware Kit, P/N 548185

Features

- ◆ Lug hardware kit provides sixteen (16) sets of 3/8-16 hardware for TPL-B distribution panels. Kit includes (16) 3/8-16 Nuts, (16) 3/8" Flat Washers, and (16) 3/8" Lock Washers.

Ordering Notes

- 1) Order Kit P/N 548185, as required.

Battery Busbar Extension Kit (P/N 562364)

Features

- Provides busbar extension plates and mounting hardware for extending battery busbars through the top of a List 23 and List 24 distribution cabinet. The hot side busbar extension plate (P/N 562363) provides five (5) pairs of clearance holes for 3/8" hardware on 1" centers, and the return side busbar extension plate (P/N 562362) provides four (4) pairs of clearance holes for 3/8" hardware on 1" centers. The hot side allows back-to-back lug landing for up to ten lugs, and the return side allows back-to-back lug landing for up to eight lugs. See "Battery Input Illustration" on page 103.

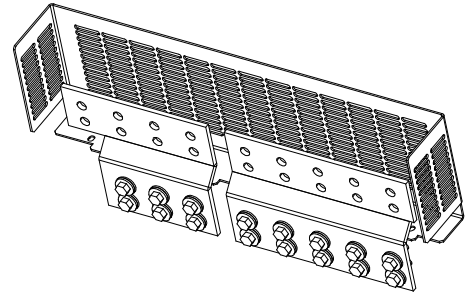

Ordering Notes

- 1) Order one (1) kit P/N 562364 per List 23 and List 24 distribution cabinet, as required.

Battery Landing Busbar Kit (P/N 553584)

Features

- ◆ Provides a Battery Landing Busbar Kit that attaches to the distribution cabinet's battery busbars and hangs off the back of the cabinet. Six (6) battery landing positions are provided (per polarity) (1/4-20 x 0.875" studs on 0.625" centers). See "Battery Input Illustration" on page 103.

Restrictions

For use with List 21.

Ordering Notes

- 1) Order one (1) kit P/N 553584 per bay, as required.

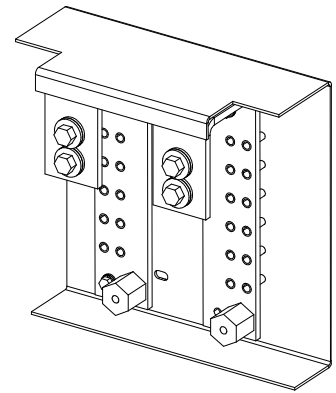

Battery Landing Busbar Kit (P/N 555478)

Features

- ◆ Provides a Battery Landing Busbar Kit that attaches to the distribution cabinet's battery busbars and hangs off the back of the cabinet. Four (4) battery landing positions are provided (per polarity) for connection of up to eight (8) battery leads (back-to-back) (per polarity) (1/4-20 x 0.875" studs on 0.625" centers). See "Battery Input Illustration" on page 103.

Restrictions

For use with Lists 22, 23, and 24.

Ordering Notes

- 1) Order one (1) kit P/N 555478 per bay, as required.

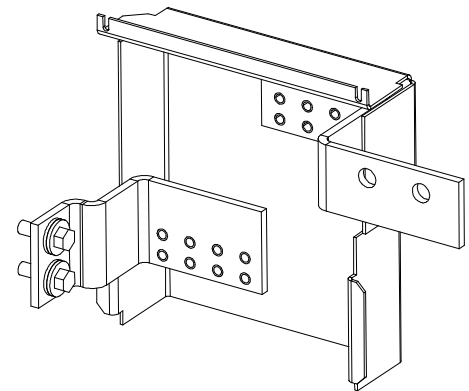

Distribution Devices

Bullet Nose Type Circuit Breakers and Bullet Nose Type Fuseholders e/w TPS/TLS Fuses

Features

- ◆ Each circuit breaker (as listed in Table 11 and Table 12) plugs into one, two, or three mounting position(s) on a distribution panel containing bullet nose type distribution positions.
- ◆ A single fuseholder provides for installation of a 3 A to 100 A Bussmann TPS type or Littelfuse TLS type fuse (as listed in Table 13). This fuseholder plugs into a single mounting position on a distribution panel containing bullet nose type distribution positions. This fuseholder provides a GMT-A alarm type fuse, which operates open to provide an alarm indication if the associated distribution fuse opens.

Restrictions

For use in Lists AA, AB, AL, AN, BA, BB, DA, DB, DC, DD, DE, DF, DG, DH, DJ, and DK.

Load should not exceed 80% of device rating.

Install distribution devices from left to right, starting with the highest capacity and working to the lowest capacity.

See the distribution panel list descriptions for additional restrictions.

Ordering Notes

- 1) Order circuit breakers as required per Table 11 or Table 12.
- 2) Order fuses as required per Table 13. For each fuse ordered, also order one (1) P/N 117201 bullet nose type fuseholder.
- 3) See Table 22 for recommended load distribution wire sizes and lugs.
- 4) When ordering 125 A through 300 A circuit breakers; associated crimp lugs may be ordered from Table 10.
When ordering 125 A through 200 A circuit breakers; lug adapter busbar kit P/N 520989, 522786, or 534449 may be ordered per circuit breaker (see *Lug Adapters* in this section).
When ordering 225 A through 300 A circuit breakers; lug adapter busbar kit P/N 514714 or 514717 may be ordered per circuit breaker (see *Lug Adapters* in this section).

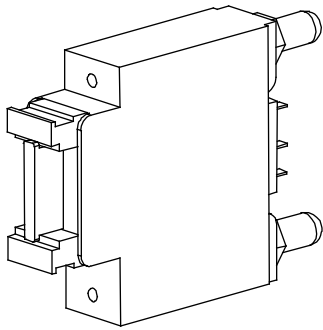

Bullet Nose Fuseholder

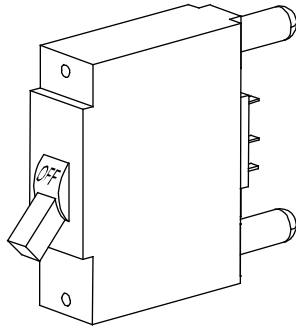

Toggle Handle
 Bullet Nose Circuit Breaker

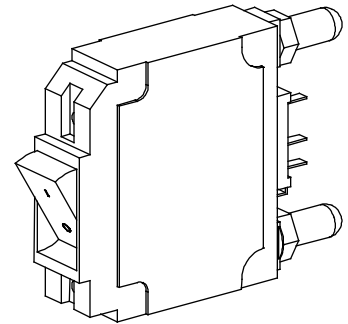

Rocker Handle
 Bullet Nose Circuit Breaker

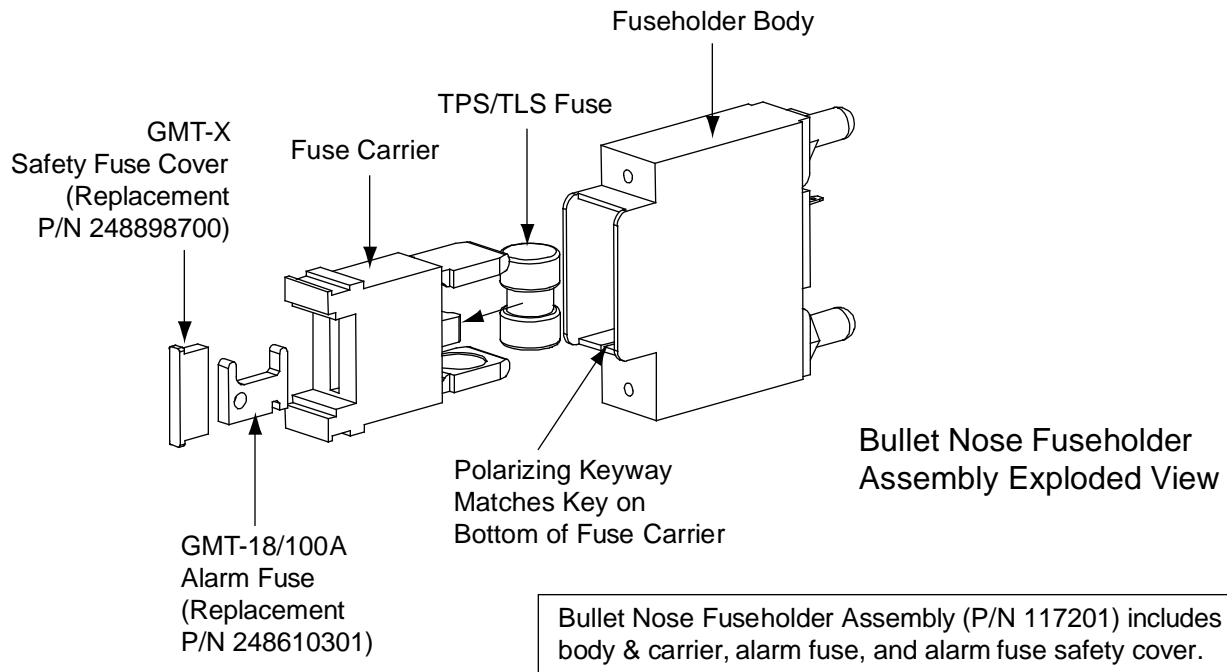

Bullet Nose Fuseholder Assembly (P/N 117201) includes body & carrier, alarm fuse, and alarm fuse safety cover.

Vertiv™ NetSure™ 710NPBA DC Power System
System Application Guide

Ampere Rating	Number of Poles	Number of Mounting Positions Required	Part Number	
			Electrical Trip ¹ (White Handle)	Electrical/ Mechanical Trip ² (Black Handle)
1	1	1	102272	101596
3	1	1	102273	101597
5	1	1	102274	101598
10	1	1	102275	101599
15	1	1	102276	101600
20	1	1	102277	101601
25	1	1	102278	101602
30	1	1	102279	101603
35	1	1	102280	101604
40	1	1	102281	101605
45	1	1	121998	121997
50	1	1	102282	101606
60	1	1	102283	101607
70	1	1	102284	101608
75	1	1	102285	101609
80	1	1	121996	121995
90	1	1	138887	138888
100	1	2	102286	101610
125	2	3	516991	516838
150	2	3	516993	516839
175	2	3	144883	144884
200	2	3	121831	121832
225	3	4	144885	144886
250	3	4	121835	121836
300	3	4	149075	149076

Circuit Breaker Alarm Operation:

- ¹ Provides an alarm during an electrical trip condition only.
- ² Provides an alarm during an electrical or manual trip condition.

Note: Electrical Trip only circuit breakers are not typically used for battery disconnect circuit breakers.

Table 11
Toggle Handle Bullet Nose Type Circuit Breakers

Vertiv™ NetSure™ 710NPBA DC Power System
System Application Guide

Ampere Rating	Number of Poles	Number of Mounting Positions Required	Part Number	
			Electrical Trip ¹ (White Handle)	Electrical/ Mechanical Trip ² (Black Handle)
1	1	1	142856	142878
3	1	1	142857	142879
5	1	1	142858	142880
10	1	1	142859	142881
15	1	1	142861	142882
20	1	1	142862	142883
25	1	1	142863	142884
30	1	1	142864	142885
35	1	1	142865	142886
40	1	1	142866	142887
45	1	1	142867	142888
50	1	1	142868	142889
60	1	1	142869	142890
70	1	1	142870	142891
75	1	1	142871	142892
80	1	1	142872	142901
100	1	2	142873	142902
125	2	3	142874	142903
150	2	3	142875	142904
200	2	3	142876	142905
250	3	4	142877	142906

Circuit Breaker Alarm Operation:

- ¹ Provides an alarm during an electrical trip condition only.
- ² Provides an alarm during an electrical or manual trip condition.

Note: *Electrical Trip only circuit breakers are not typically used for battery disconnect circuit breakers.*

Table 12
Rocker Handle Bullet Nose Circuit Breakers

Vertiv™ NetSure™ 710NPBA DC Power System
System Application Guide

Ampere Rating	Part Number	Bussmann P/N	Littelfuse P/N
3	248230900	TPS-3	TLS003
5	248231000	TPS-5	TLS005
6	248231200	TPS-6	TLS006
10	248231500	TPS-10	TLS010
15	248231800	TPS-15	TLS015
20	248232100	TPS-20	TLS020
25	248232400	TPS-25	TLS025
30	248232700	TPS-30	TLS030
40	248233300	TPS-40	TLS040
50	248233900	TPS-50	TLS050
60	248234200	TPS-60	TLS060
70	248234500	TPS-70	TLS070
80	118413	--	TLS080
90	118414	--	TLS090
100	118415	--	TLS100
Bullet Nose Type Fuseholder		P/N 117201 (Includes Fuseholder, 18/100 A GMT-A Alarm Fuse, and GMT-X Safety Fuse Cover)	

Table 13
Bullet Nose Type Fuseholders and TPS/TLS Fuses

Vertiv™ NetSure™ 710NPBA DC Power System

System Application Guide

Optional Bullet Nose Type 6-Position GMT Distribution Fuse Block, P/N 550224, (6) GMT Fuse Positions

Features

- ◆ Provides six (6) load distribution fuse positions (1/4 A to 15 A GMT alarm-type fuses).
- ◆ Single voltage distribution (+24 V or -48 V).
- ◆ Mounts in two (2) distribution positions of a “bullet nose” distribution panel.
- ◆ Screw clamp type load and load return terminals provided.
- ◆ Includes six (6) dummy fuses equipped with safety fuse covers.

Restrictions

Can be used in a List AA, AB, BA, BB, DA, DB, DC, and DD distribution panel only.

Occupies two (2) bullet device mounting positions.

Can only be installed in the 1-2, 3-4, 17-18, 19-20, 21-22, and 23-24 positions of the distribution panel.

Terminal block wire size capacity: 24 AWG to 14 AWG.

35 A maximum capacity per block.

Maximum GMT fuse size is 15 A.

Ordering Notes

- 1) Order optional Bullet Nose Type 6-Position GMT Fuse Block (P/N 550224) as required.
- 2) Order fuses as required per Table 14.

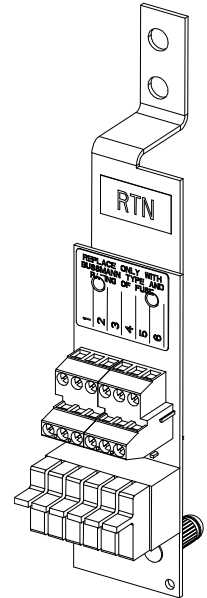

Optional Bullet Nose Type 6-Position GMT Distribution Fuse Block, P/N 549017, (6) GMT Fuse Positions

Features

- ◆ Provides six (6) load distribution fuse positions (1/4 A to 15 A GMT alarm-type fuses).
- ◆ Single voltage distribution (-48 V or +24 V).
- ◆ Mounts in two (2) distribution positions of a “bullet nose” distribution panel.
- ◆ Screw clamp type load and load return terminals provided.
- ◆ Includes six (6) dummy fuses equipped with safety fuse covers.

Restrictions

Can be used in a List AL, AN, DE, DF, DG, DH, DJ, and DK distribution panel only.

Can only be installed in the 1-2, 3-4, 5-6, 7-8, 15-16, 17-18, 19-20, 21-22, 23-24, and 25-26 positions of the distribution panel.

Occupies two (2) bullet device mounting positions.

Terminal block wire size capacity is 26 AWG to 14 AWG.

35 A maximum capacity per block.

Maximum GMT fuse size is 15 A.

Ordering Notes

- 1) Order optional Bullet Nose Type 6-Position GMT Fuse Block (P/N 549017) as required. Provides one alarm fuse distribution assembly, ground return link, and hardware.
- 2) Order fuses as required per Table 13.

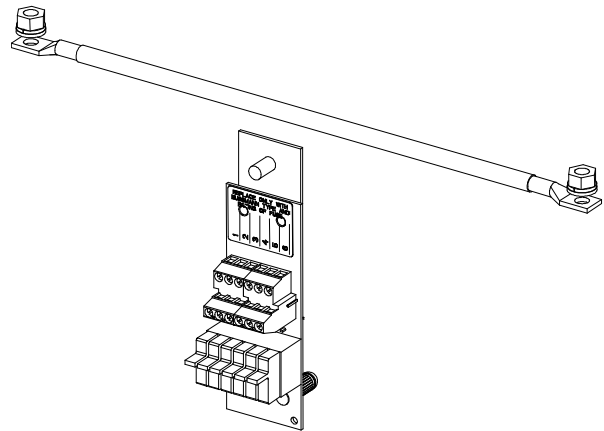

Vertiv™ NetSure™ 710NPBA DC Power System

System Application Guide

GMT Type Load Distribution Fuses

Features

- ◆ An optional “Bullet Nose Type 6-Position GMT Distribution Fuse Block, P/N 550224 or 549017” is available for additional load distribution.

Restrictions

When used for power distribution, load should not exceed 80% of device rating, except 10 and 15 amp fuses, for which load should not exceed 70% of device rating.

Ordering Notes

- 1) Order fuses as required per Table 14.

Ampere Rating	Part Number	Fuse Color
18/100 (GMT-A)	248610301	---
1/4	248610200	VIOLET
1/2	248610300	RED
3/4	248610500	BROWN
1-1/3	248610700	WHITE
2	248610800	ORANGE
3	248610900	BLUE
5	248611000	GREEN
7-1/2	248611300	BLACK-WHITE
10	248611200	RED-WHITE
15	248611500	RED-BLUE
Replacement Safety Fuse Cover (GMT-Y)	102774	---
Replacement Dummy Fuse	248872600	---

Table 14
GMT Fuses

Vertiv™ NetSure™ 710NPBA DC Power System

System Application Guide

GJ/218 Type Circuit Breakers

Restrictions

For use in Lists AC, AD, BC, BD, AM, and AP.
 Load should not exceed 80% of device rating.
 Refer to Table 15 for required distribution row mounting positions.

Ordering Notes

- 1) Order circuit breakers as required per Table 15.
- 2) Order a jumper kit as required for each circuit breaker per Table 15.
- 3) See Table 23 for recommended load distribution wire sizes and lugs.

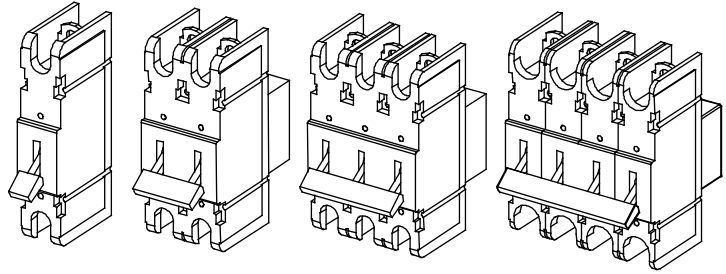

GJ/218 Circuit Breakers

Ampere Rating	No. of Positions	P/N Electrical/ Mechanical Trip ¹ without Internal Shunt	P/N Electrical Trip ² without Internal Shunt	Breaker Mounting Kit (without Shunt)	P/N Electrical/ Mechanical Trip ¹ with Internal Shunt (25 mV @ full rated load) ³	P/N Electrical Trip ² with Internal Shunt (25 mV @ full rated load) ³	Breaker Mounting Kit (with Shunt)
100	1	256621700	256621300	503787	123580	516184	513731
125	1	256621600	256621400	503787	123631	516187	513731
150	1	256621800	256622400	503787	123632	516185	513731
175	1	256621900	256622500	503787	123633	516186	513731
200	1	256622200	256622600	503787	123634	516188	513731
225	1	256622900	256622700	503787	123635	516189	513731
250	1	256623500	256623400	503787	123636	516190	513731
300	2	256625300	103572	513961	550250	550253	554092
400	2	256626200	256626300	513961	550251	550254	554092
600	3	256628200	103571	513957	550252	550255	554093
800	4	121657	121658	554091	--	550249	554094

^{1,2} Circuit Breaker Alarm Operation:

¹ Provides an alarm during an electrical or manual trip condition.

² Provides an alarm during an electrical trip condition only.

³ Extended shunt leads are 22 AWG stranded wire, approximately 7-10 ft. long from exit point at bottom of distribution cabinet. Each shunt lead is equipped with a 49.9 ohm current limiting resistor. Shunt leads are factory wired to SM-DU+ (if ordered).

Note: Electrical Trip only circuit breakers are not typically used for battery disconnect circuit breakers.

Table 15
GJ/218 Circuit Breakers

TPH Type Fuses

Restrictions

For use in Lists AE, AF, AG, AH, BE, BF, BG, and BH.

Load should not exceed 80% of device rating.

Ordering Notes

- 1) Order fuses as required per Table 16.
- 2) See Table 23 for recommended load distribution wire sizes and lugs.

Ampere Rating	Part Number
70	119437
80	119438
100	119440
150	119581
200	119582
225	119583
250	119584
300	119585
400	119586
500	119587
600	119588

Table 16
TPH Fuses

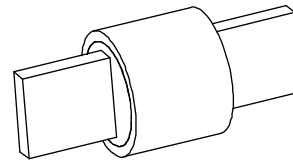

TPH Fuse

Vertiv™ NetSure™ 710NPBA DC Power System

System Application Guide

TPL-B Type Fuses

Restrictions

For use in Lists AJ and AK.

Load should not exceed 80% of device rating.

Ordering Notes

- 1) Order fuses as required per Table 17.
- 2) See Table 23 for recommended load distribution wire sizes and lugs.

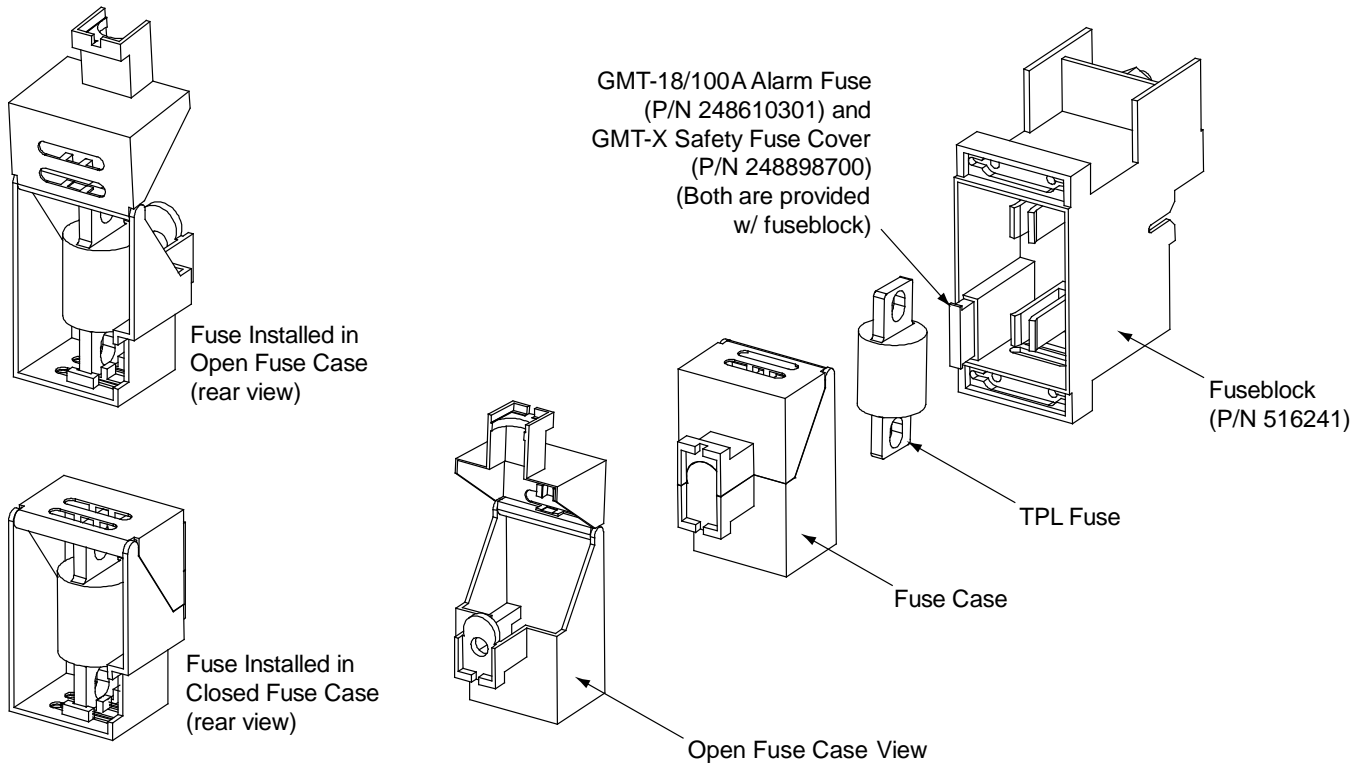

Ampere Rating	Part Number
70	248251500
80	248252000
100	248252600
150	248253300
200	248254000
225	248254500
250	248255000

Table 17
TPL-B Fuses

User Replaceable Alarm, Reference, and Control Fuses

Ordering Notes

- Order replacement fuses as required per Table 18.

Assembly	Desig.	Function	Size (Amperes)	Type	Part No.
Distribution Panel with TPH Fuse Block(s)	FA	Fuse Alarm	1/4	Bussmann GMT	248610200
	--	--	--	Safety Fuse Cover (GMT-X)	248898700
TPS/TLS Fuseholders (P/N 117201)	FA	Fuse Alarm	18/100	Bussmann GMT-A	248610301
	--	--	--	Safety Fuse Cover (GMT-X)	248898700
TPL-B Fuseholders	FA	Fuse Alarm	18/100	Bussmann GMT-A	248610301
	--	--	--	Safety Fuse Cover (GMT-X)	248898700

Table 18
Replaceable Alarm, Reference, and Control Fuses

User Replaceable Components

Ordering Notes

- Refer to the following table.

Item	Part Number
Rectifier Module	1R242500 or 1R243000
Converter Module	1C24481500
ACU+ Controller	1M820DNA
NCU Controller	1M830DNA
IB5 Second Ethernet Port Board	10146319
System Interface Circuit Card	556166
IB2 Interface Board	MA4C5U31
Temp Probe Sensor	552822
EIB Extended Interface Board	MA455U41
SM-DU+ with Shunt Interface Board	548078
LVD Driver Circuit Card	540972
LVD Driver Lite Circuit Card	547873
Manual Battery Disconnect Circuit Card	540973

Table 19
User Replaceable Components

RECOMMENDED WIRE SIZES, BRANCH CIRCUIT PROTECTION, CRIMP LUGS, AND WIRING ILLUSTRATIONS

Relay Rack Frame Grounding Requirements

For relay rack grounding requirements, refer to the current edition of the American National Standards Institute (ANSI) approved National Fire Protection Association’s (NFPA) National Electrical Code (NEC), applicable local codes, and your specific site requirements.

A customer’s grounding network lead can be attached to the top of each relay rack. Provision is made for installing a lead with a two-hole lug that has 1/4” bolt clearance holes on 5/8” centers. Refer to Table 8 for lug selection.

AC Input Connections (if List A1 not furnished)

AC Input Branch Circuit Protection and Wire Size Selection (to AC Termination Assembly)

Refer to Table 20 or Table 21 for recommended wire sizes and branch circuit protection.

AC INPUT (to List 40 AC Input Termination Assembly) Connection Points for Individual Rectifier AC Input Branch Circuits are Provided				
Input Voltage	Input Current ⁽⁴⁾	Overcurrent Protection ⁽¹⁾	40 °C Ambient Temperature ⁽²⁾	
			Wire AWG ^{(2) (3)}	Conduit Size (in.)
208	15.7 A	20 A	12	3/4
240	13.6 A			

- ¹ The AC input branch circuit protective device should be of the time-delay or high inrush type.
- ² Wire sizes based on recommendations of the American National Standards Institute (ANSI) approved National Fire Protection Association’s (NFPA) National Electrical Code (NEC). Table 310-16 for copper wire at 90 °C conductor temperature; operating in ambient of 40°C was used. For other operating ambient temperatures, refer to the National Electrical Code. For operation in countries where the NEC is not recognized, follow applicable codes.
- ³ Equipment grounding conductors must be provided with the AC input conductors supplied to the shelf. Frame ground terminals must be connected to earth ground, not power system neutral. Equipment grounding conductor size based on recommendations of the NEC Table 250-122 for copper wire. If aluminum or copper clad aluminum grounding conductor is used, refer to Table 250-122 for increased conductor size. For operation in countries where the NEC is not recognized, follow applicable codes.
- ⁴ Input current based on R24-3000 rectifier module.

Table 20
Recommended AC Input Branch Circuit Protection and Wire Size
when Using List 40 Individual Rectifier AC Input Termination Assembly

AC INPUT (to List 41 AC Input Termination Assembly) Connection Points for Dual Rectifier AC Input Branch Circuits are Provided (two rectifiers per AC feed)				
Input Voltage	Input Current ⁽⁴⁾	Overcurrent Protection ⁽¹⁾	40 °C Ambient Temperature ⁽²⁾	
			Wire AWG ^{(2) (3)}	Conduit Size (in.)
208	31.4 A	40 A	8	3/4
240	27.2 A	35 A		

- ¹ The AC input branch circuit protective device should be of the time-delay or high inrush type.
- ² Wire sizes based on recommendations of the American National Standards Institute (ANSI) approved National Fire Protection Association's (NFPA) National Electrical Code (NEC). Table 310-16 for copper wire at 90 °C conductor temperature; operating in ambient of 40°C was used. For other operating ambient temperatures, refer to the National Electrical Code. For operation in countries where the NEC is not recognized, follow applicable codes.
- ³ Equipment grounding conductors must be provided with the AC input conductors supplied to the shelf. Frame ground terminals must be connected to earth ground, not power system neutral. Equipment grounding conductor size based on recommendations of the NEC Table 250-122 for copper wire. If aluminum or copper clad aluminum grounding conductor is used, refer to Table 250-122 for increased conductor size. For operation in countries where the NEC is not recognized, follow applicable codes.
- ⁴ Input current based on R24-3000 rectifier modules.

Table 21
 Recommended AC Input Branch Circuit Protection and Wire Size
 when Using List 41 Dual Rectifier AC Input Termination Assembly

AC Input Connections to AC Termination Assembly Wiring Illustrations

AC INPUT CONNECTIONS,
INDIVIDUAL PCU FEED (581127000 LIST 40),
WHEN EQUIPPED WITH 588705201

NOTE:
WIRING TO AN EXPANSION
SHELF IS DONE AT THE
REAR OF THE EXPANSION
SHELF.

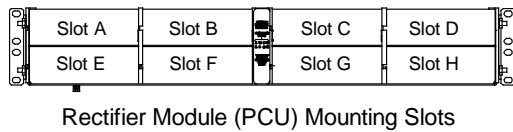

(4-Row Cabinet Shown,
Others Similar)
Front Door Removed in
Illustration for Clarity

AC Wireway
Cover
AC Input
Connector Cover

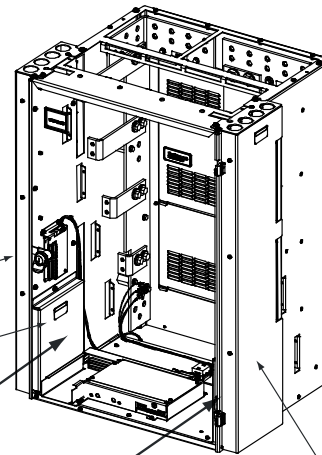

AC Wireway
Cover

Inside View
Left Side

Inside View
Right Side



INDIVIDUAL RECTIFIER (PCU) AC INPUT FEEDS
208-240VAC, 50/60Hz, SINGLE PHASE

INDIVIDUAL RECTIFIER (PCU) AC INPUT FEEDS
208-240VAC, 50/60Hz, SINGLE PHASE

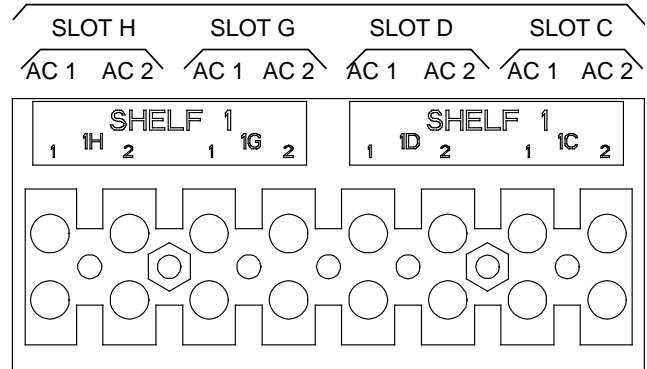
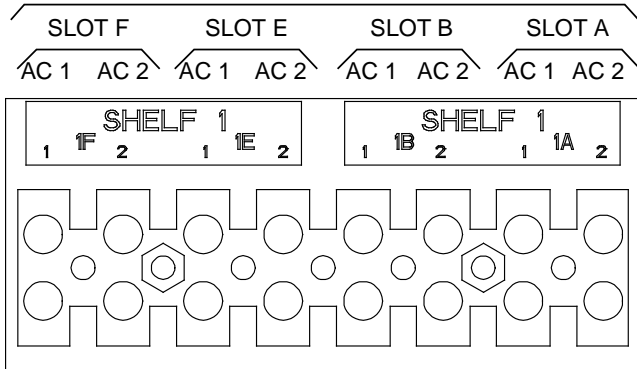

Vertiv™ NetSure™ 710NPBA DC Power System

System Application Guide

AC INPUT CONNECTIONS, INDIVIDUAL PCU FEED (581127000 LIST 40), WHEN EQUIPPED WITH 588705202

NOTE:
WIRING TO AN EXPANSION
SHELF IS DONE AT THE
REAR OF THE EXPANSION
SHELF.

(4-Row Cabinet Shown,
Others Similar)
Front Door Removed in
Illustration for Clarity

AC Wireway
Cover
AC Input
Connector Cover

AC Wireway
Cover

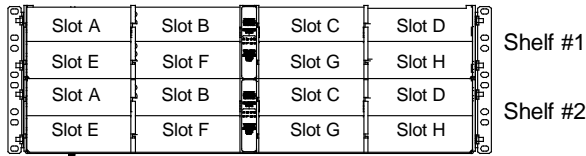
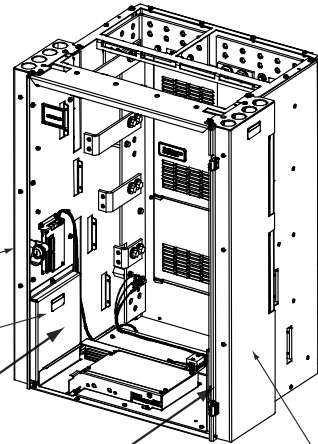

Rectifier Module (PCU) Mounting Slots

Inside View
Left Side



INDIVIDUAL RECTIFIER (PCU) AC INPUT FEEDS
208-240VAC, 50/60Hz, SINGLE PHASE

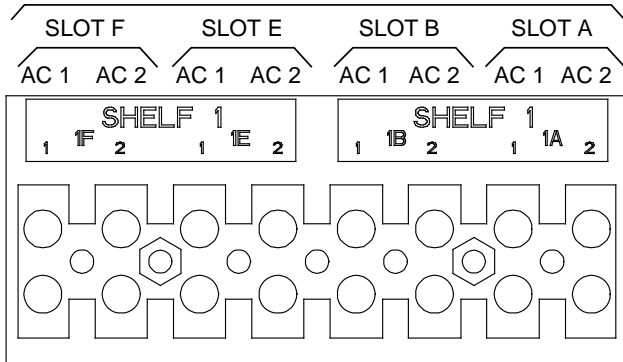

Inside View
Right Side



INDIVIDUAL RECTIFIER (PCU) AC INPUT FEEDS
208-240VAC, 50/60Hz, SINGLE PHASE

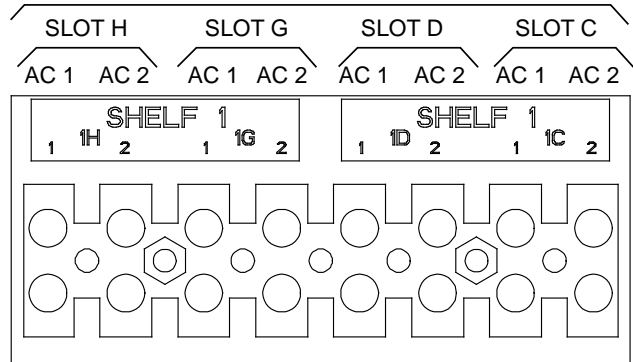

INDIVIDUAL RECTIFIER (PCU) AC INPUT FEEDS
208-240VAC, 50/60Hz, SINGLE PHASE

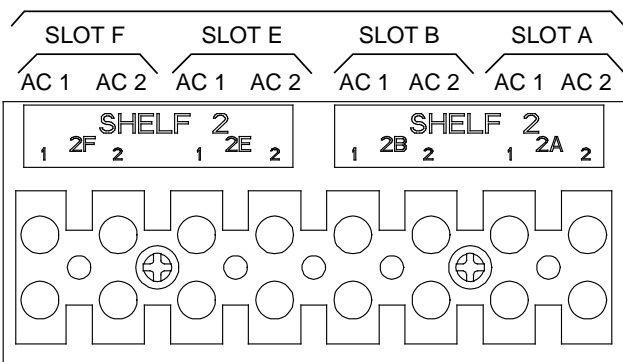

INDIVIDUAL RECTIFIER (PCU) AC INPUT FEEDS
208-240VAC, 50/60Hz, SINGLE PHASE

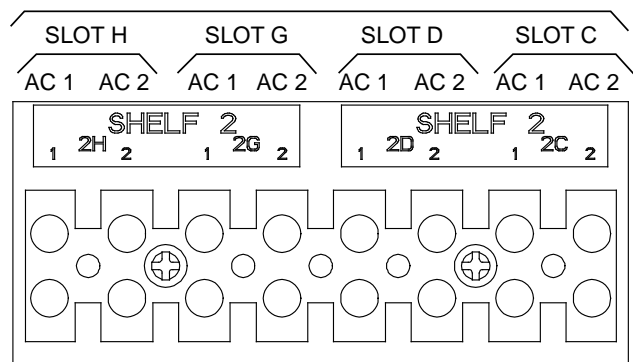

Vertiv™ NetSure™ 710NPBA DC Power System

System Application Guide

AC INPUT CONNECTIONS, INDIVIDUAL PCU FEED (581127000 LIST 40), WHEN EQUIPPED WITH 588705203

NOTE:
WIRING TO AN EXPANSION
SHELF IS DONE AT THE
REAR OF THE EXPANSION
SHELF.

(4-Row Cabinet Shown,
Others Similar)
Front Door Removed in
Illustration for Clarity

AC Wireway
Cover
AC Input
Connector Cover

AC Wireway
Cover

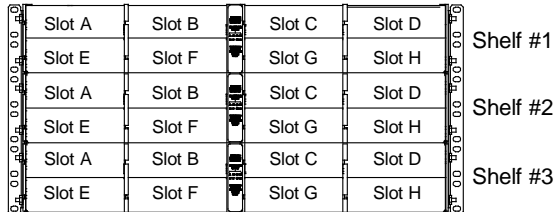

Rectifier Module (PCU) Mounting Slots

Inside View
Left Side

Inside View
Right Side

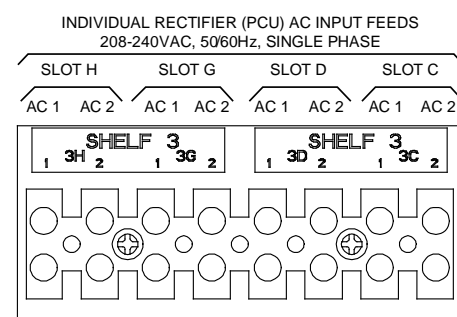
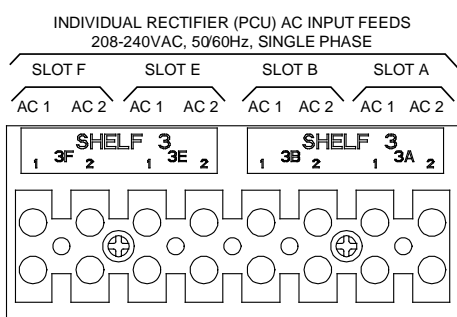
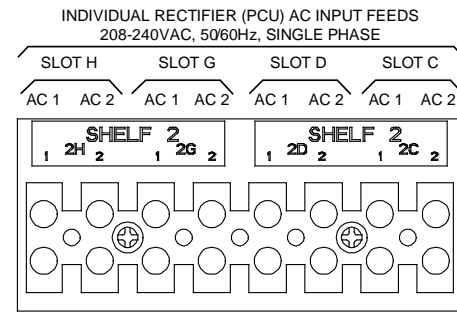
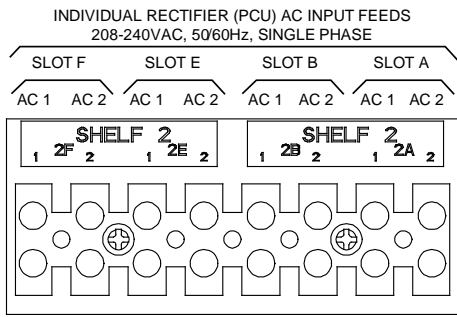
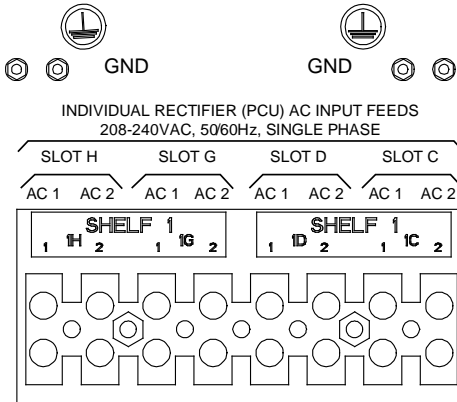
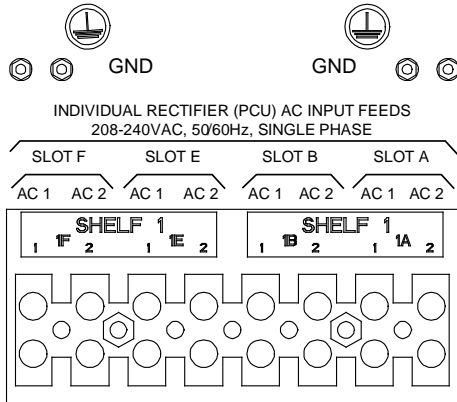

Vertiv™ NetSure™ 710NPBA DC Power System

System Application Guide

AC INPUT CONNECTIONS, INDIVIDUAL PCU FEED (581127000 LIST 40), WHEN EQUIPPED WITH 588705204

NOTE:
WIRING TO AN EXPANSION
SHELF IS DONE AT THE
REAR OF THE EXPANSION
SHELF.

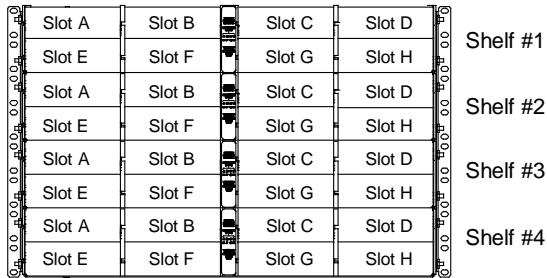
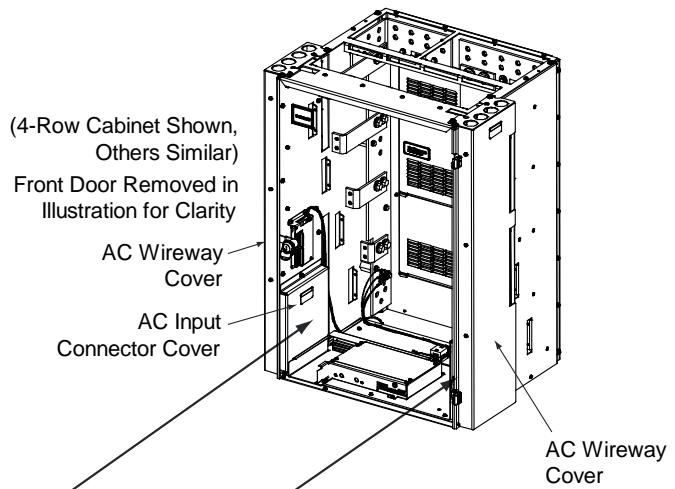

Rectifier Module (PCU) Mounting Slots

Inside View
Left Side

Inside View
Right Side

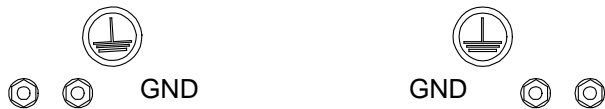

INDIVIDUAL RECTIFIER (PCU) AC INPUT FEEDS
208-240VAC, 50/60Hz, SINGLE PHASE

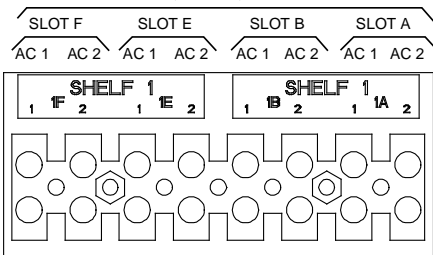

INDIVIDUAL RECTIFIER (PCU) AC INPUT FEEDS
208-240VAC, 50/60Hz, SINGLE PHASE

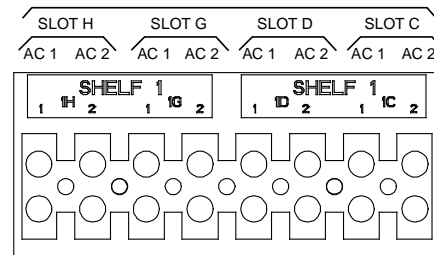

INDIVIDUAL RECTIFIER (PCU) AC INPUT FEEDS
208-240VAC, 50/60Hz, SINGLE PHASE

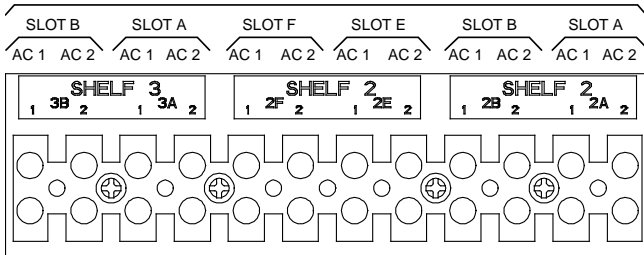

INDIVIDUAL RECTIFIER (PCU) AC INPUT FEEDS
208-240VAC, 50/60Hz, SINGLE PHASE

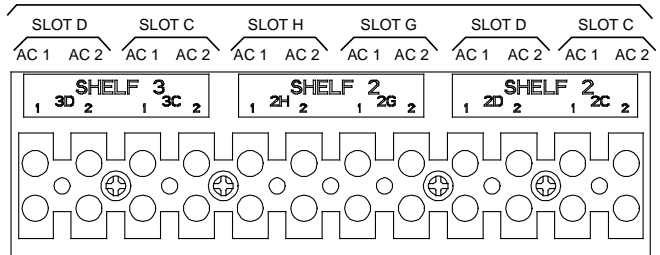

INDIVIDUAL RECTIFIER (PCU) AC INPUT FEEDS
208-240VAC, 50/60Hz, SINGLE PHASE

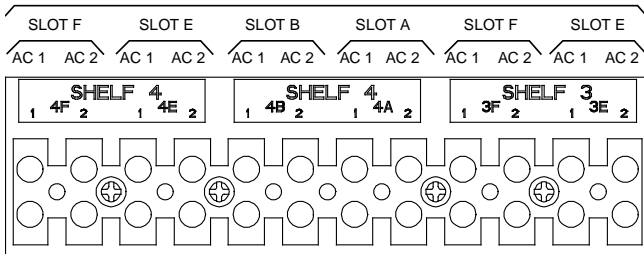

INDIVIDUAL RECTIFIER (PCU) AC INPUT FEEDS
208-240VAC, 50/60Hz, SINGLE PHASE

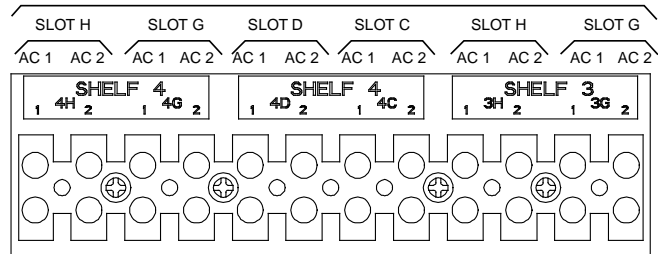

Vertiv™ NetSure™ 710NPBA DC Power System

System Application Guide

AC INPUT CONNECTIONS, DUAL PCU FEED (581127000 LIST 41), WHEN EQUIPPED WITH 588705201

NOTE:
WIRING TO AN EXPANSION
SHELF IS DONE AT THE
REAR OF THE EXPANSION
SHELF.

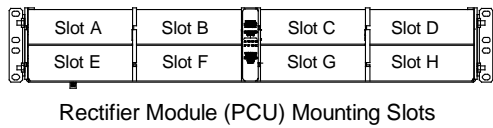

(4-Row Cabinet Shown,
Others Similar)
Front Door Removed in
Illustration for Clarity

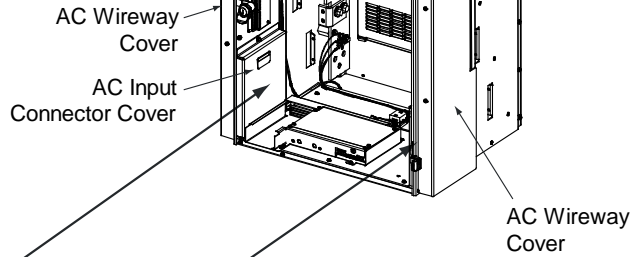

Inside View
Left Side



DUAL RECTIFIER (PCU) AC INPUT FEEDS
208-240VAC, 50/60Hz, SINGLE PHASE

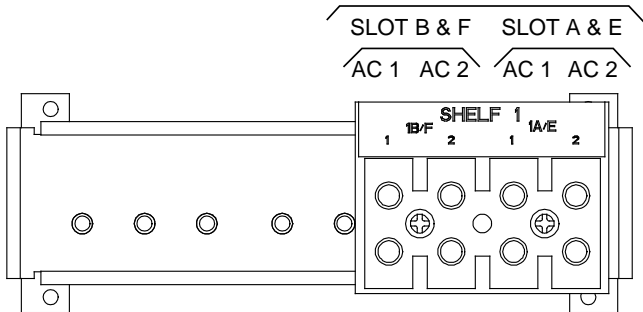

Inside View
Right Side



DUAL RECTIFIER (PCU) AC INPUT FEEDS
208-240VAC, 50/60Hz, SINGLE PHASE

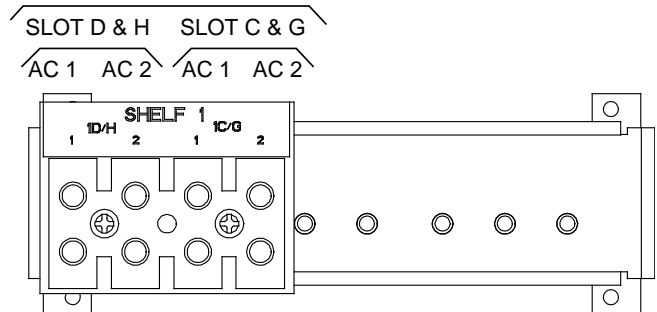

Vertiv™ NetSure™ 710NPBA DC Power System

System Application Guide

AC INPUT CONNECTIONS, DUAL PCU FEED (581127000 LIST 41), WHEN EQUIPPED WITH 588705202

NOTE:
WIRING TO AN EXPANSION
SHELF IS DONE AT THE
REAR OF THE EXPANSION
SHELF.

(4-Row Cabinet Shown,
Others Similar)
Front Door Removed in
Illustration for Clarity

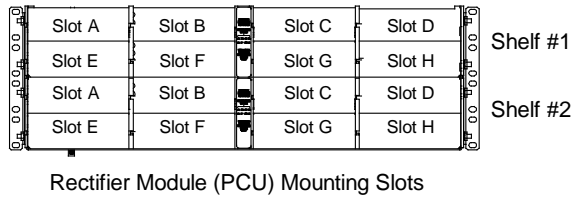
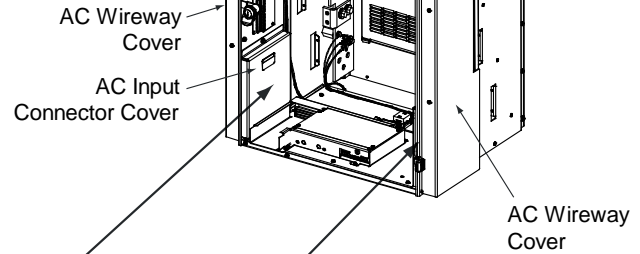

Inside View
Left Side

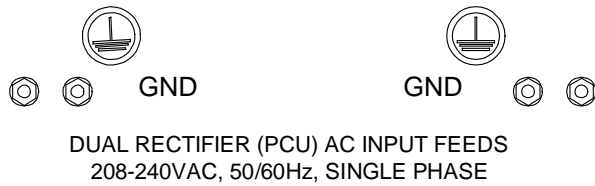

Inside View
Right Side

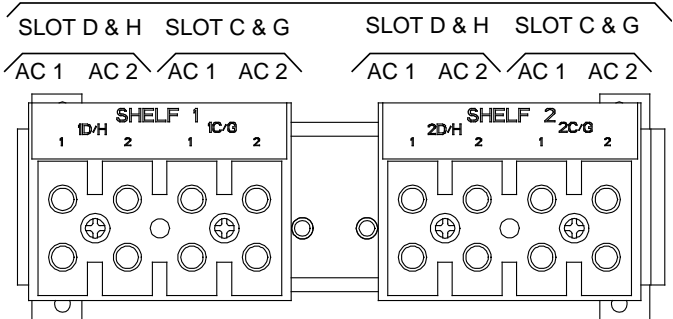
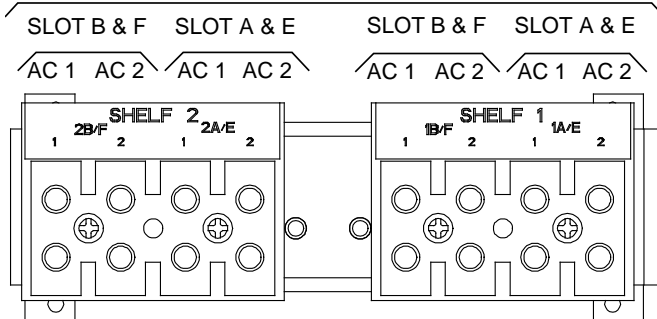
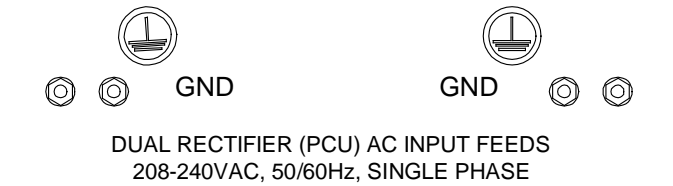

Vertiv™ NetSure™ 710NPBA DC Power System

System Application Guide

AC INPUT CONNECTIONS, DUAL PCU FEED (581127000 LIST 41), WHEN EQUIPPED WITH 588705203

NOTE:
WIRING TO AN EXPANSION
SHELF IS DONE AT THE
REAR OF THE EXPANSION
SHELF.

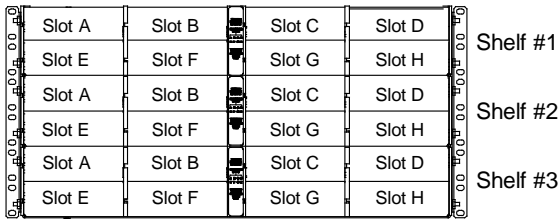

Rectifier Module (PCU) Mounting Slots

(4-Row Cabinet Shown,
Others Similar)
Front Door Removed in
Illustration for Clarity

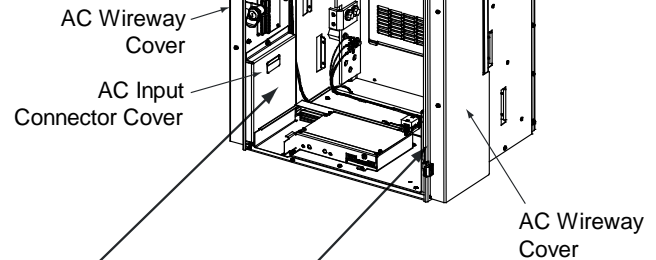

Inside View
Left Side

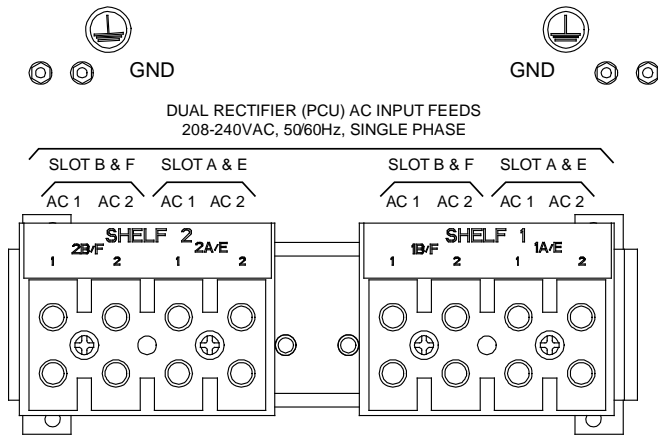

Inside View
Right Side

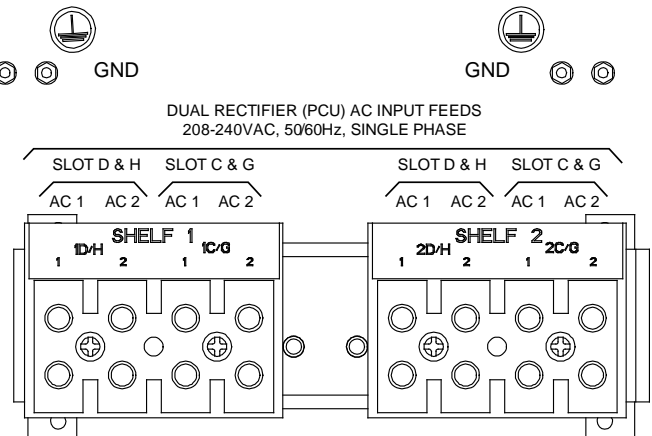

DUAL RECTIFIER (PCU) AC INPUT FEEDS
208-240VAC, 50/60Hz, SINGLE PHASE

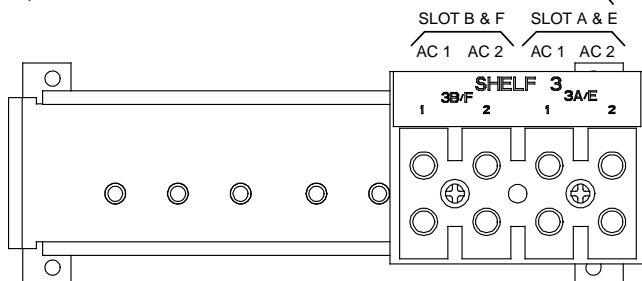

DUAL RECTIFIER (PCU) AC INPUT FEEDS
208-240VAC, 50/60Hz, SINGLE PHASE

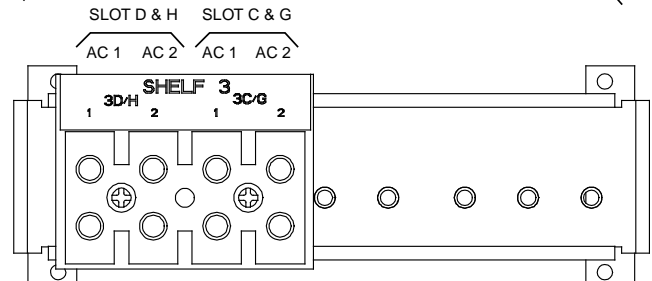

Vertiv™ NetSure™ 710NPBA DC Power System

System Application Guide

AC INPUT CONNECTIONS, DUAL PCU FEED (581127000 LIST 41), WHEN EQUIPPED WITH 588705204

NOTE:
WIRING TO AN EXPANSION
SHELF IS DONE AT THE
REAR OF THE EXPANSION
SHELF.

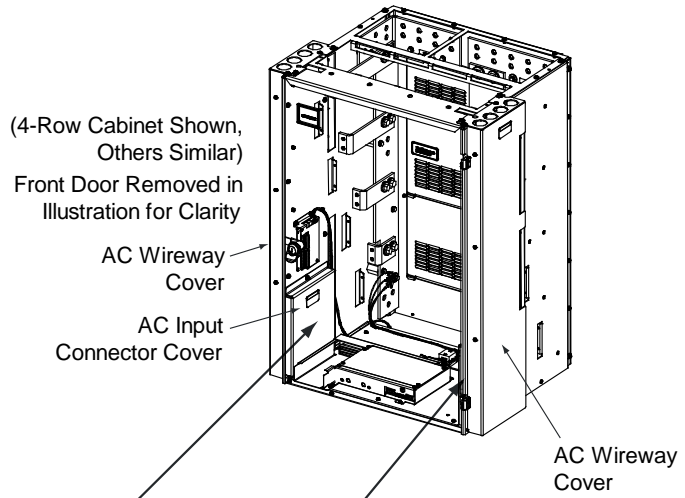

Slot A	Slot B	Slot C	Slot D	Shelf #1
Slot E	Slot F	Slot G	Slot H	
Slot A	Slot B	Slot C	Slot D	
Slot E	Slot F	Slot G	Slot H	
Slot A	Slot B	Slot C	Slot D	Shelf #2
Slot E	Slot F	Slot G	Slot H	
Slot A	Slot B	Slot C	Slot D	
Slot E	Slot F	Slot G	Slot H	
Slot A	Slot B	Slot C	Slot D	Shelf #3
Slot E	Slot F	Slot G	Slot H	
Slot A	Slot B	Slot C	Slot D	
Slot E	Slot F	Slot G	Slot H	
Slot A	Slot B	Slot C	Slot D	Shelf #4
Slot E	Slot F	Slot G	Slot H	
Slot A	Slot B	Slot C	Slot D	
Slot E	Slot F	Slot G	Slot H	

Rectifier Module (PCU) Mounting Slots

Inside View
Left Side

Inside View
Right Side

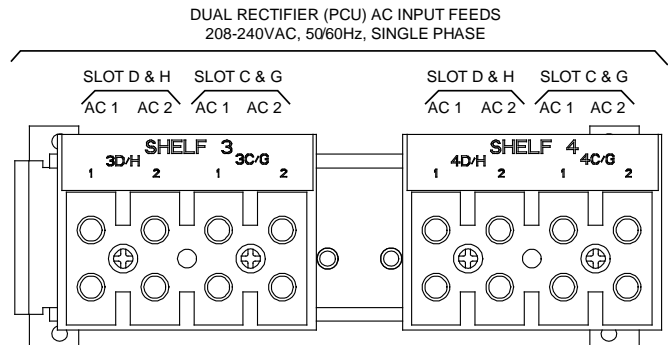
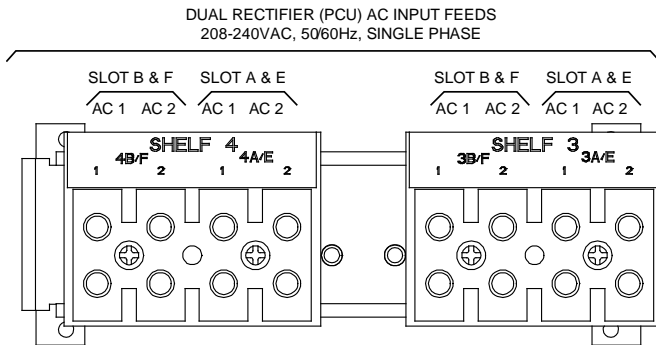
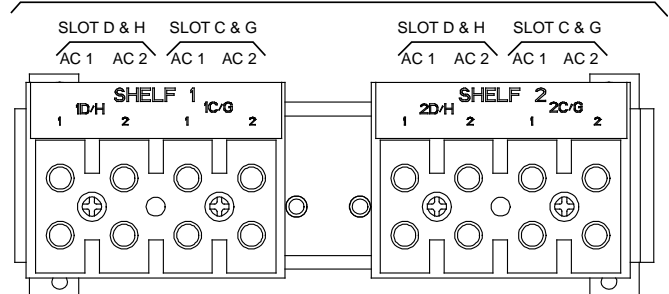
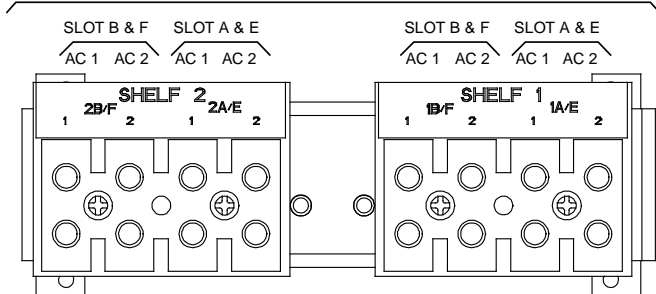

AC Input, AC Output, and Frame Ground Connections when List A1 Furnished

List A1, A2 Inverter System AC Input Branch Circuit Protection and Wire Size Selection

Refer to the separate Inverter instruction manuals for recommended wire size and branch circuit protection.

AC Input, AC Output, and Frame Ground Connections when List A1 Furnished Wiring Illustrations

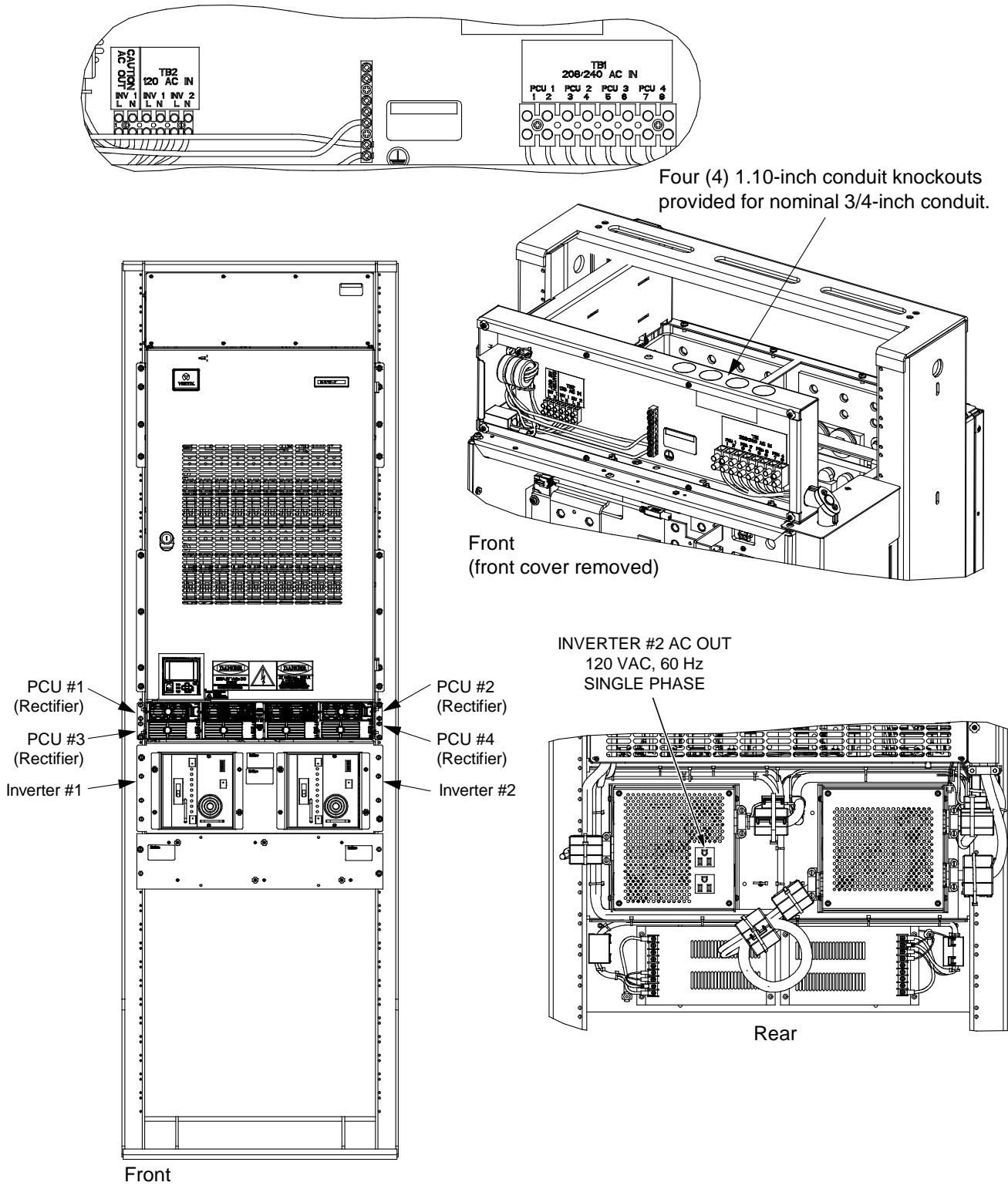

Vertiv™ NetSure™ 710NPBA DC Power System

System Application Guide

Bonding Jumpers Removal:

List A1: Before connecting AC input wiring to the inverter #1 AC input terminals, remove the green-yellow “neutral to ground” bonding jumper that is connected between the terminal of TB2 labeled “120 AC IN INV 1 N” and frame ground terminal block TB3.

List A2: Before connecting AC input wiring to the inverter #2 AC input terminals, remove the green-yellow “neutral to ground” bonding jumper that is connected between the terminal of TB2 labeled “120 AC IN INV 2 N” and frame ground terminal block TB3.

The purpose of each bonding jumper is to connect neutral to ground in case no AC input cable is connected to the system. (When an inverter is used as the power source for a separately derived premises wiring system, the wiring should be grounded per recommendations set forth in the NEC.)

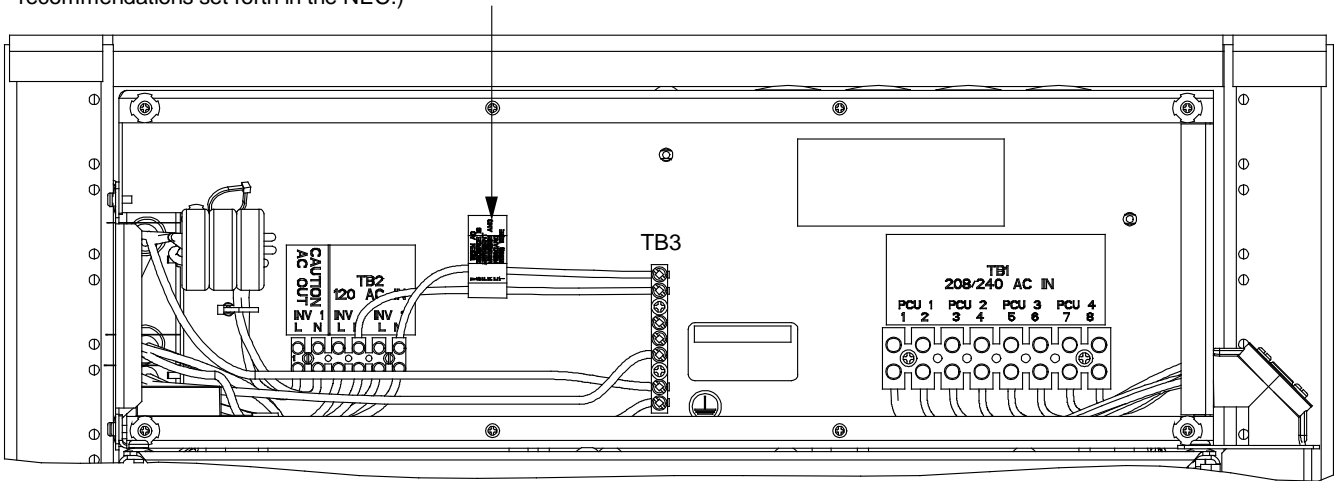

Front
(front cover removed)

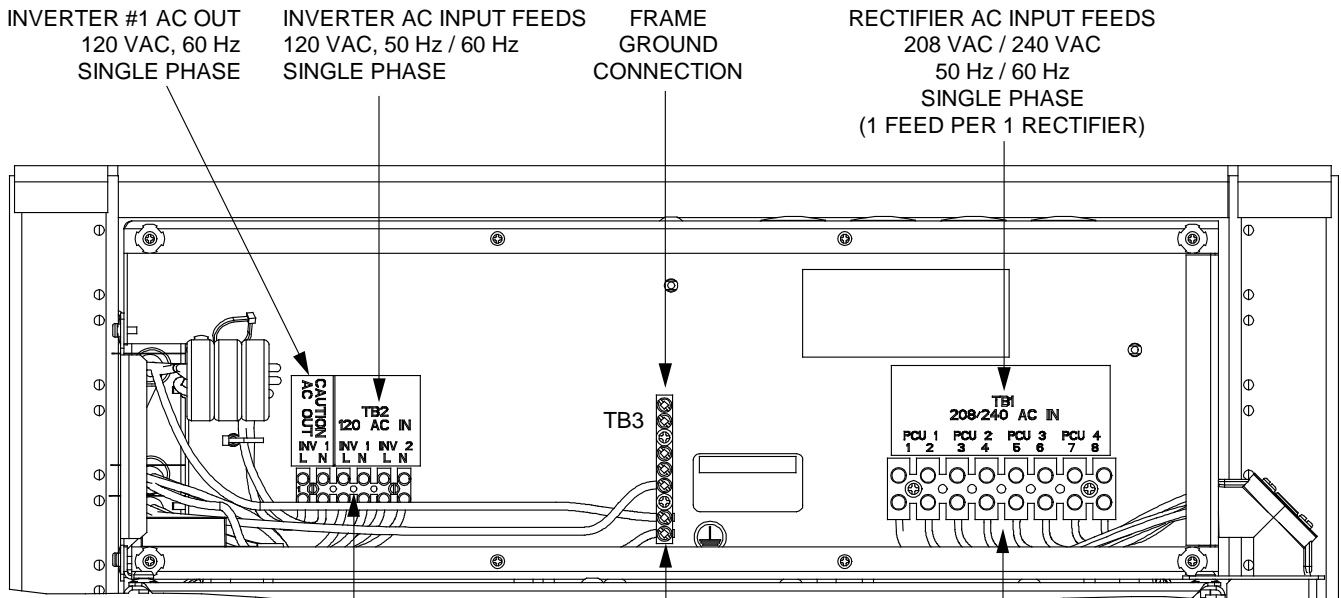

Front
(front cover removed)

Wire Size Capacity:
12 AWG to 24 AWG.
Recommended Torque:
5 in-lbs.

Wire Size Capacity:
4 AWG to 14 AWG.
Recommended Torque:
20 in-lbs.

Wire Size Capacity:
6 AWG to 14 AWG.
Recommended Torque:
11 in-lbs.

AC Input Connections to Field Installed Module Mounting Assemblies

AC Input Branch Circuit Protection and Wire Size Selection (when wiring to Expansion Rectifier Module Mounting Assembly)

Refer to Power Data Sheet PD588705200 (PD588705201, PD588705202, PD588705203, PD588705204).

AC Input Connections to Expansion Rectifier Module Mounting Assembly(s) Wiring Illustrations

Refer to Power Data Sheet PD588705200 (PD588705201, PD588705202, PD588705203, PD588705204).

External Alarm, Reference, Monitoring, and Control

External Alarm, Reference, Monitoring, and Control Wire Sizes

Recommended wire size is 22 AWG for loop lengths up to 200 ft. and 18 AWG to 20 AWG for loop lengths over 200 ft.

External Alarm, Reference, Monitoring, and Control Illustrations

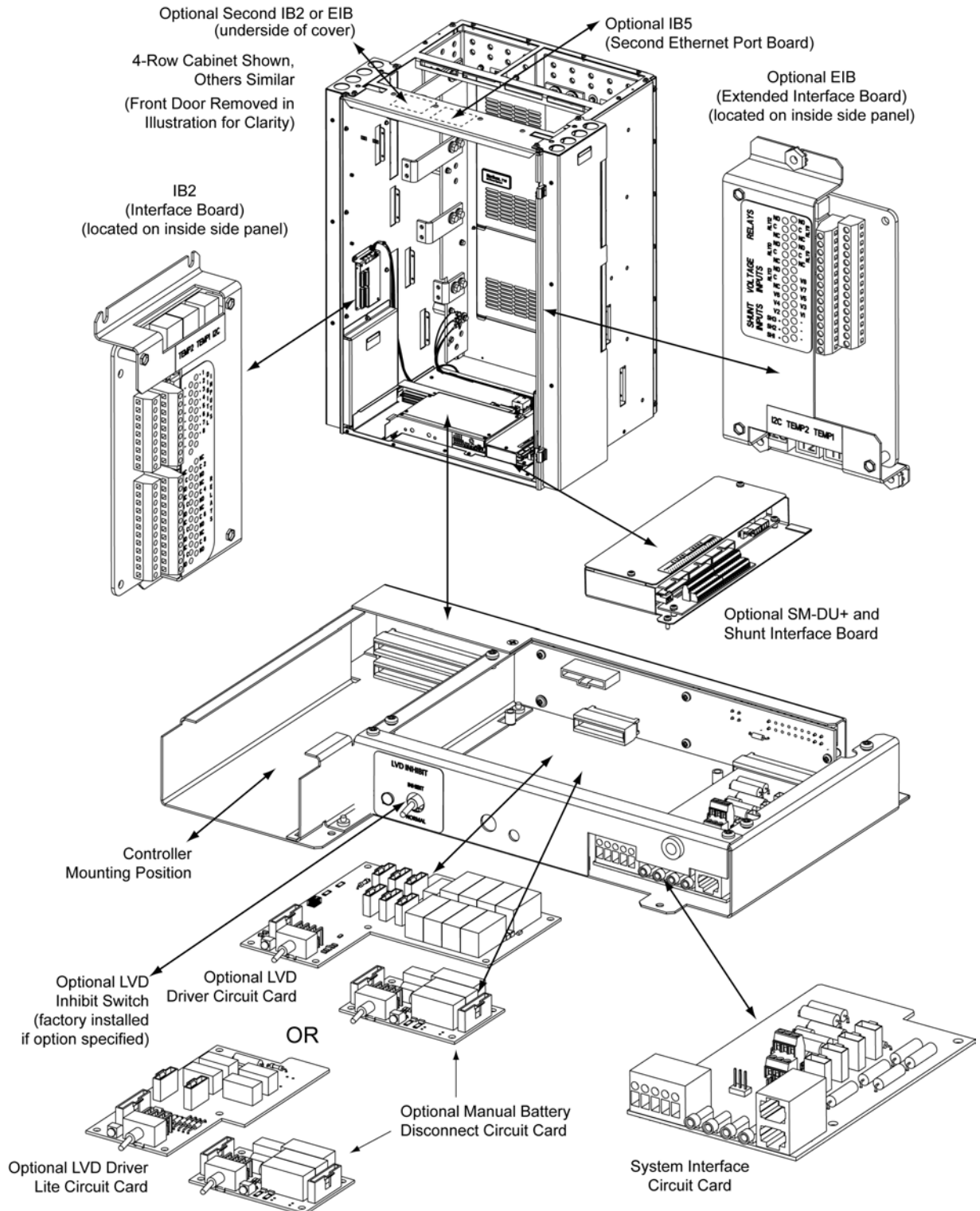

System Interface
Circuit Card

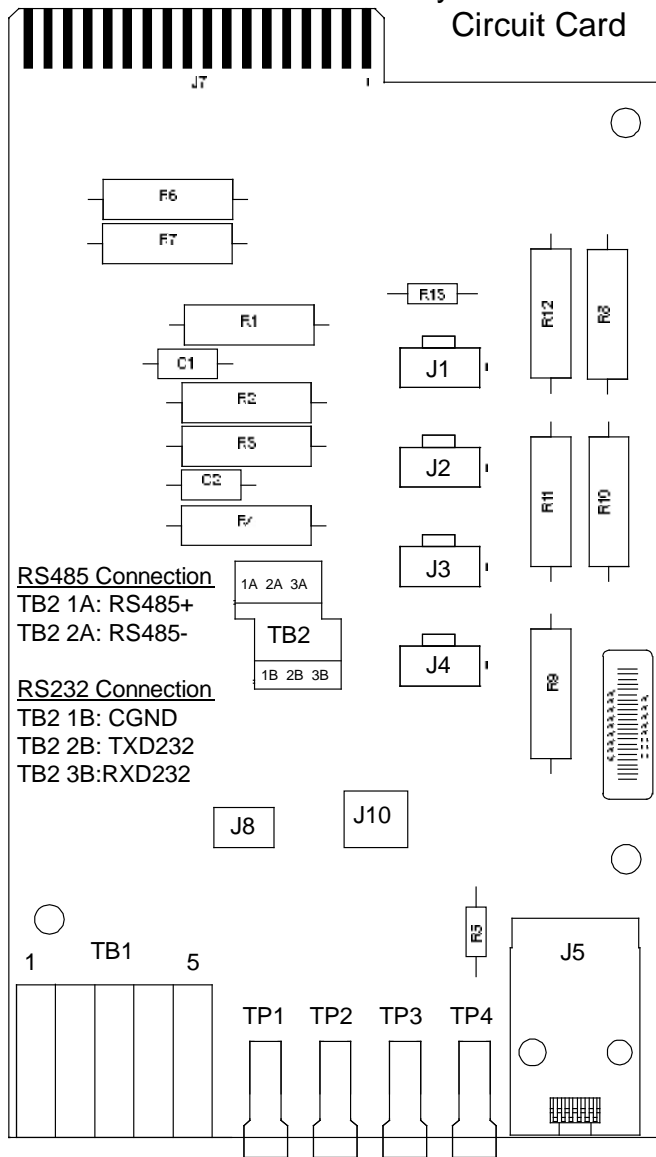

RS485 Connection

TB2 1A: RS485+
TB2 2A: RS485-

RS232 Connection

TB2 1B: CGND
TB2 2B: TXD232
TB2 3B: RXD232

J1, J2, J3, J4
Distribution Panels FA Inputs

J8
Selects to power Controller from "Battery Power" or not.

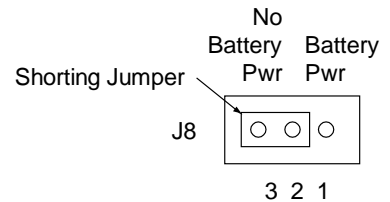

J10
Battery Monitoring External / Internal (see TB1-4 and TB1-5 for external monitoring points)

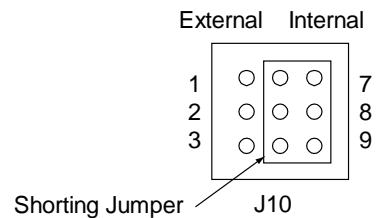

J5
CAN

TB1-1: Battery Tray FA
TB1-2: External Battery FA
TB1-3: External System FA
TB1-4: External Battery Monitoring (-)
TB1-5: External Battery Monitoring (+)

TP1 (+) and TP2 (-)
System Voltage Monitoring

TP3 (+) and TP4 (-)
System Load Shunt Monitoring

TB1

Wire Size Capacity: 22-12 AWG.
Recommended Torque: 3.0 in-lbs.
FA Signals: Battery applied to the terminal turns in an alarm.

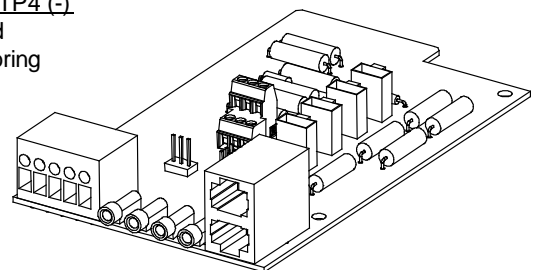

Vertiv™ NetSure™ 710NPBA DC Power System

System Application Guide

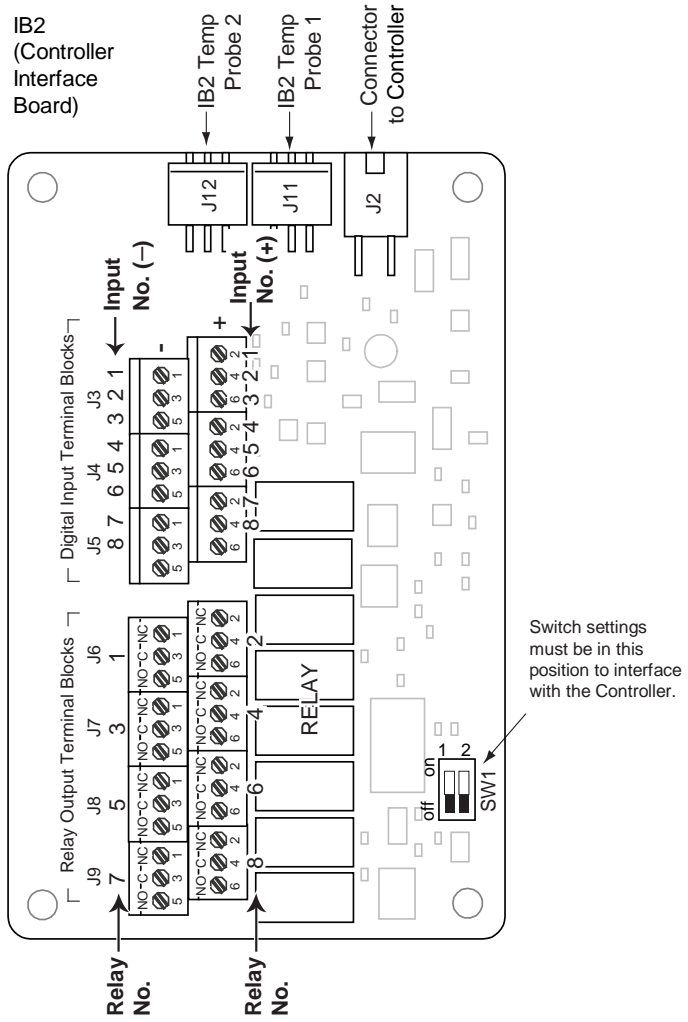
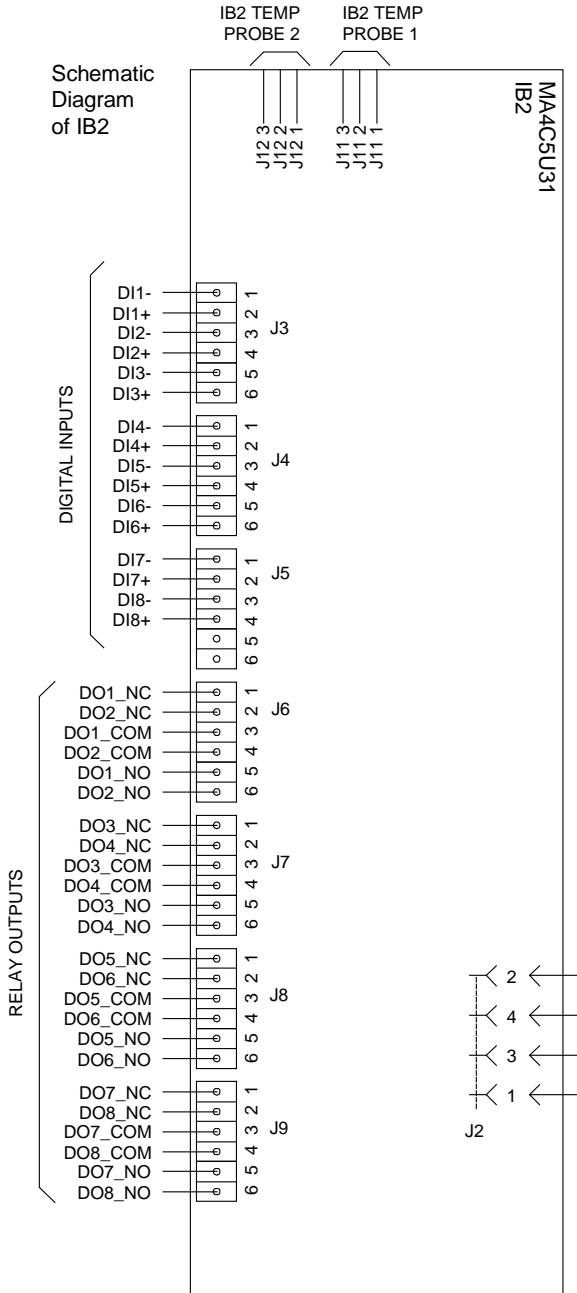

IB2 (Controller Interface Board)

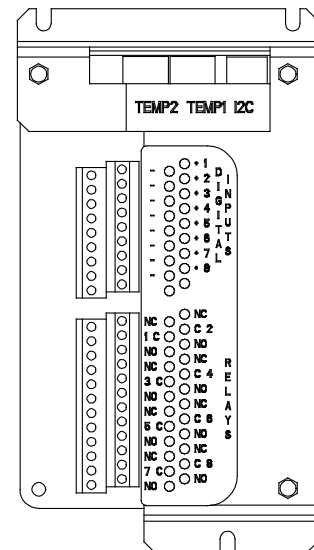

The relay assigned to “Critical Summary” alarm (relay 1 by default) will operate in the “Fail Safe Mode”. “Fail Safe Mode” means Relay 1 is de-energized during an alarm condition, opening the contacts between the C and NO terminals, and closing the contacts between the C and NC terminals. The remaining seven (7) relays energize during an alarm condition, closing the contacts between the C and NO terminals, and opening the contacts between the C and NC terminals.

Not all I/O points may be available for customer connection (some may be used for factory system connections). The digital inputs and relay outputs may be preprogrammed for specific functions. Refer to the configuration drawing (C-drawing) supplied with your system for your system’s specific configuration.

J3-J9:

Wire Size Capacity: 16 AWG to 26 AWG.

Wire Strip Length: 0.20 inch.

Recommended Torque: 2.2 in-lbs.

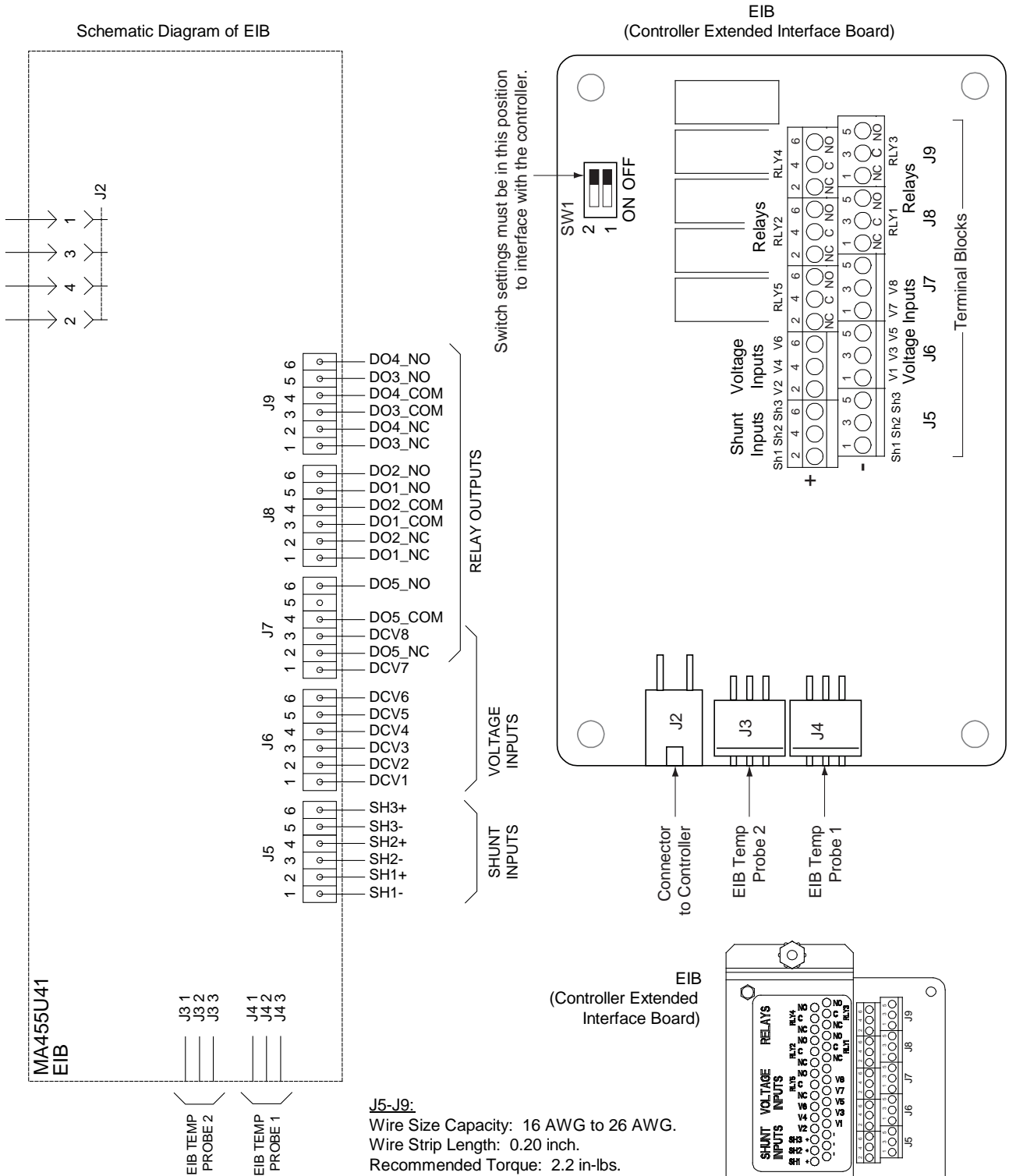

The five (5) relays energize during an alarm condition, closing the contacts between the C and NO terminals, and opening the contacts between the C and NC terminals.

Not all I/O points may be available for customer connection (some may be used for factory system connections). The relay outputs may be preprogrammed for specific functions. Refer to the configuration drawing (C-drawing) supplied with your system for your system's specific configuration.

J5-J9:
Wire Size Capacity: 16 AWG to 26 AWG.
Wire Strip Length: 0.20 inch.
Recommended Torque: 2.2 in-lbs.

Schematic Diagram of SM-DU+ and Shunt Interface Board

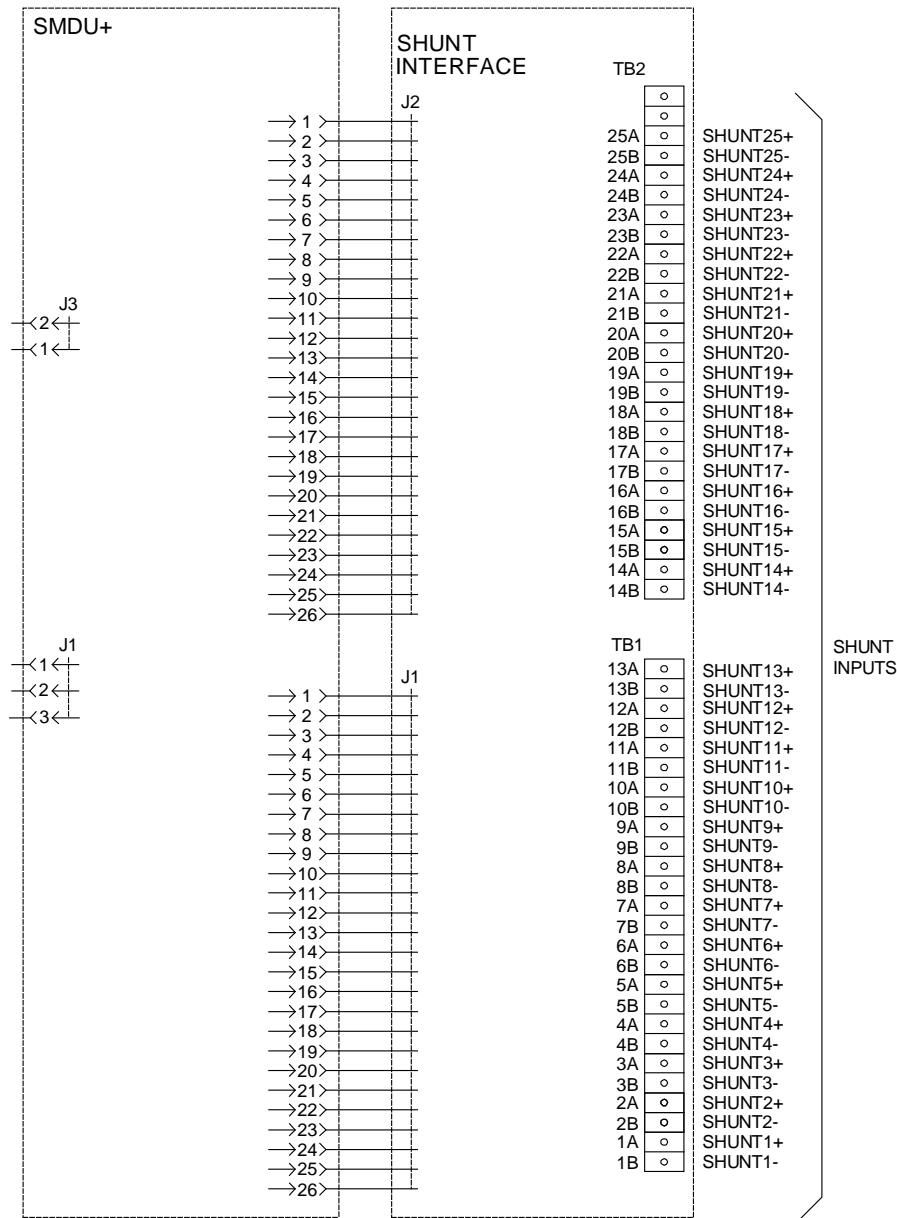

Shunt Interface Board

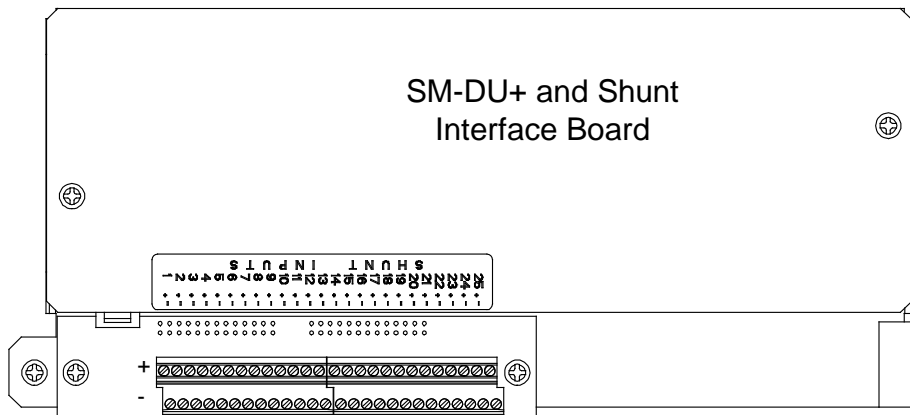
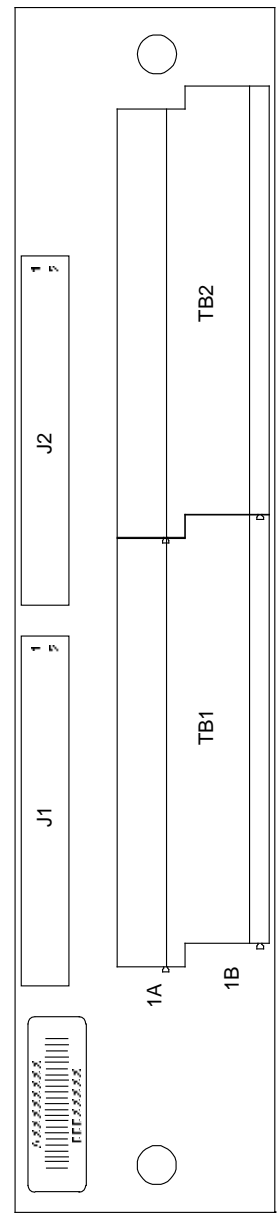

TB1 - TB2

Wire Size Capacity: 16-26 AWG.
Recommended Torque: 2.2 in-lbs.

Optional LVD Driver Circuit Card

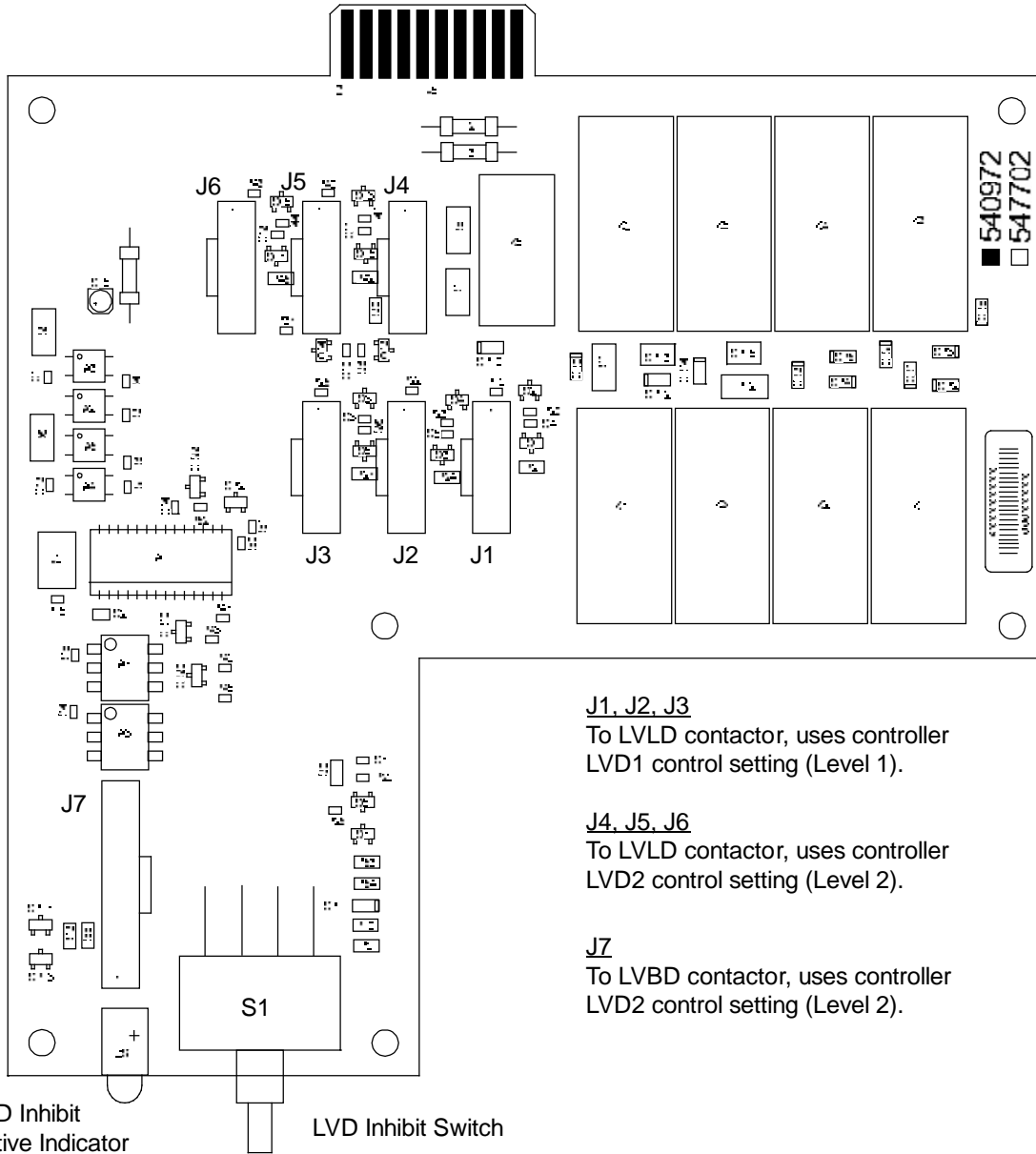

Momentary UP / Middle / Down

Momentary UP Position: Closes all LVD Contactors (inhibit mode).
Middle Position: OFF (Controller DOES NOT control LVD's) (inhibit mode).
DOWN Position: ON (Controller controls LVD's).

Notes:

1. Connects up to (4) LVLDC and (1) LVBD contactors.

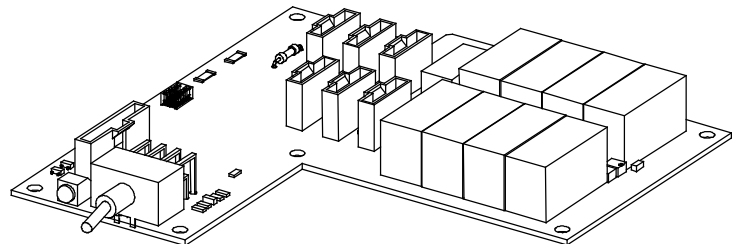

Optional LVD Driver
Lite Circuit Card

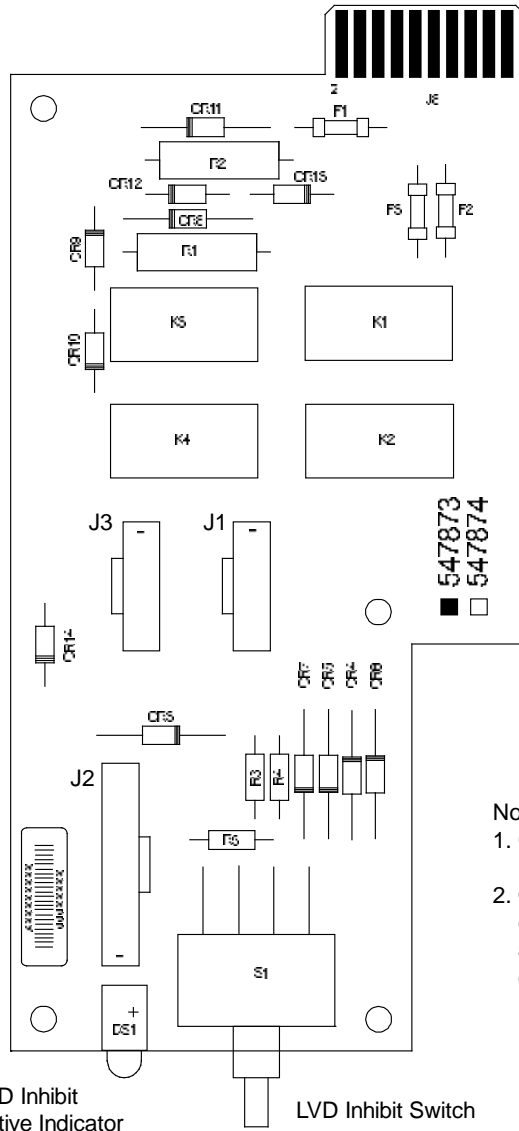

J1
To LVLD contactor, uses controller LVD1 control setting (Level 1).

J3
To LVLD contactor, uses controller LVD2 control setting (Level 2).

J2
To LVBD contactor, uses controller LVD2 control setting (Level 2).
Can only be used if it is contained in a List 21 (1-row) cabinet.

Notes:

1. Connects up to (2) LVD contactors rated at 600 A or less.
2. Only one (1) contactor per level can be accommodated. J2 and J3 are on Level 2, only one (1) of these connectors can be used at a time.

Momentary UP / Middle / Down

Momentary UP Position: Closes all LVD Contactors (inhibit mode).

Middle Position: OFF (Controller DOES NOT control LVD's) (inhibit mode).

DOWN Position: ON (Controller controls LVD's).

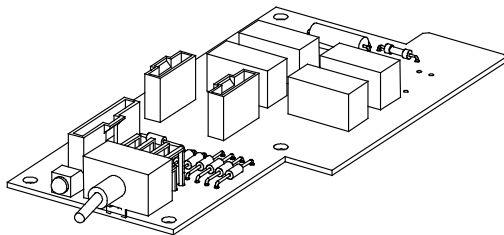

Optional Manual Battery
 Disconnect Circuit Card

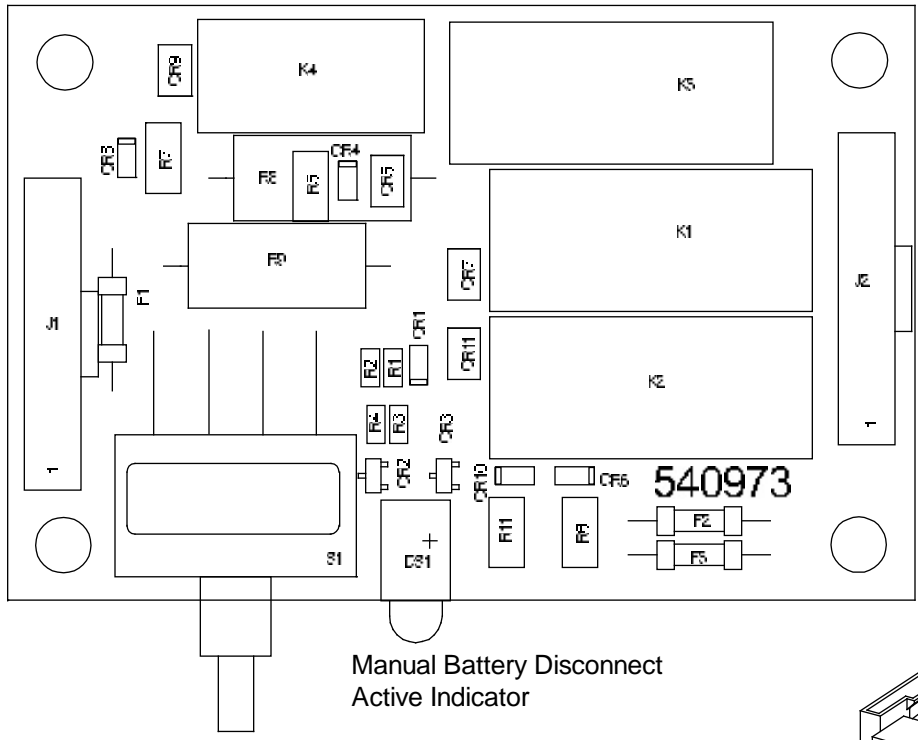

Momentary UP / Middle / Momentary Down
 Momentary UP Position: Closes Battery Disconnect Contactor
 Middle Position: Normal Operation
 Momentary DOWN Position: Opens Battery Disconnect Contactor

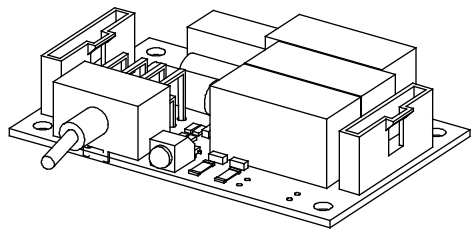

Load Distribution

Load Distribution Wire Sizes and Lugs Selection

The rating of the distribution device determines the load lead wire size requirement. The distribution panel ordered determines the lug hole size and spacing requirements. For wire size and lug selection; refer to the following.

- **When Distribution Panels using Bullet Nose Type Devices (TPS/TLS Fuses and/or Bullet Nose Type Circuit Breakers) are Provided:** Lug-terminated load leads are connected to the individual load busbars and load return busbar (if equipped) located on the distribution panel. If the distribution panel is not equipped with a load return busbar, load return connections are made to a separate return busbar.

The distribution panel's individual load busbars and load return busbar (if equipped) provide 1/4-20 studs for installation of customer-provided two-hole lugs that have 5/8 inch centers and 1/4 inch bolt clearance holes. Customer must provide (or order) lug mounting hardware. The distribution panel's individual load busbars and return busbar (if equipped) are designed to accommodate the lugs listed in Table 8 and Table 10. Use Table 22 to select recommended load distribution wire sizes and lugs for various loop lengths per fuse/circuit breaker ampere rating. Maximum size of wire to be connected to a single fuseholder/circuit breaker position is 2 AWG. For wiring up to 350 kcmil, see Table 10 or see the following part numbers in ACCESSORY DESCRIPTIONS for available adapter busbars: [514717](#), [534449](#), and [514714](#).

The separate return busbar (if furnished) provides 3/8-16 captive nuts for installation of customer-provided two-hole lugs that have 1 inch centers and 3/8 inch bolt clearance holes. Customer must provide (or order) lug mounting bolts and hardware. The separate return busbar (if furnished) are designed to accommodate the lugs listed in Table 9. Use Table 23 to select recommended load distribution wire sizes and lugs for various loop lengths per fuse/circuit breaker ampere rating.

- **When Distribution Panels using GJ/218 Circuit Breakers, TPH Fuses, or TPL-B Fuses are Provided:** Lug-terminated load leads are connected to the individual load busbars and load return busbar (if equipped) located on the distribution panel. If the distribution panel is not equipped with a load return busbar, load return connections are made to a separate return busbar.

The distribution panel's individual load busbars and load return busbar (if equipped) provide 3/8-16 captive nuts or studs for installation of customer-provided two-hole lugs that have 1 inch centers and 3/8 inch bolt clearance holes. Customer must provide (or order) lug mounting bolts (if required) and hardware. The distribution panel's individual load busbars and return busbar (if equipped) are designed to accommodate the lugs listed in Table 9. Use Table 23 to select recommended load distribution wire sizes and lugs for various loop lengths per fuse/circuit breaker ampere rating. Also use these tables when using lug adapters 534449 or 514714 for bullet panels.

The separate return busbar (if furnished) provides 3/8-16 captive nuts for installation of customer-provided two-hole lugs that have 1 inch centers and 3/8 inch bolt clearance holes. Customer must provide (or order) lug mounting bolts and hardware. The separate return busbar (if furnished) are designed to accommodate the lugs listed in Table 9. Use Table 23 to select recommended load distribution wire sizes and lugs for various loop lengths per fuse/circuit breaker ampere rating.

Load Distribution (Distribution Panels) Illustrations

Refer to the illustrations located under the Distribution Panel List descriptions in this document.

Load Distribution Wiring (Optional Bullet Nose 6-Position GMT Fuse Block) Illustration

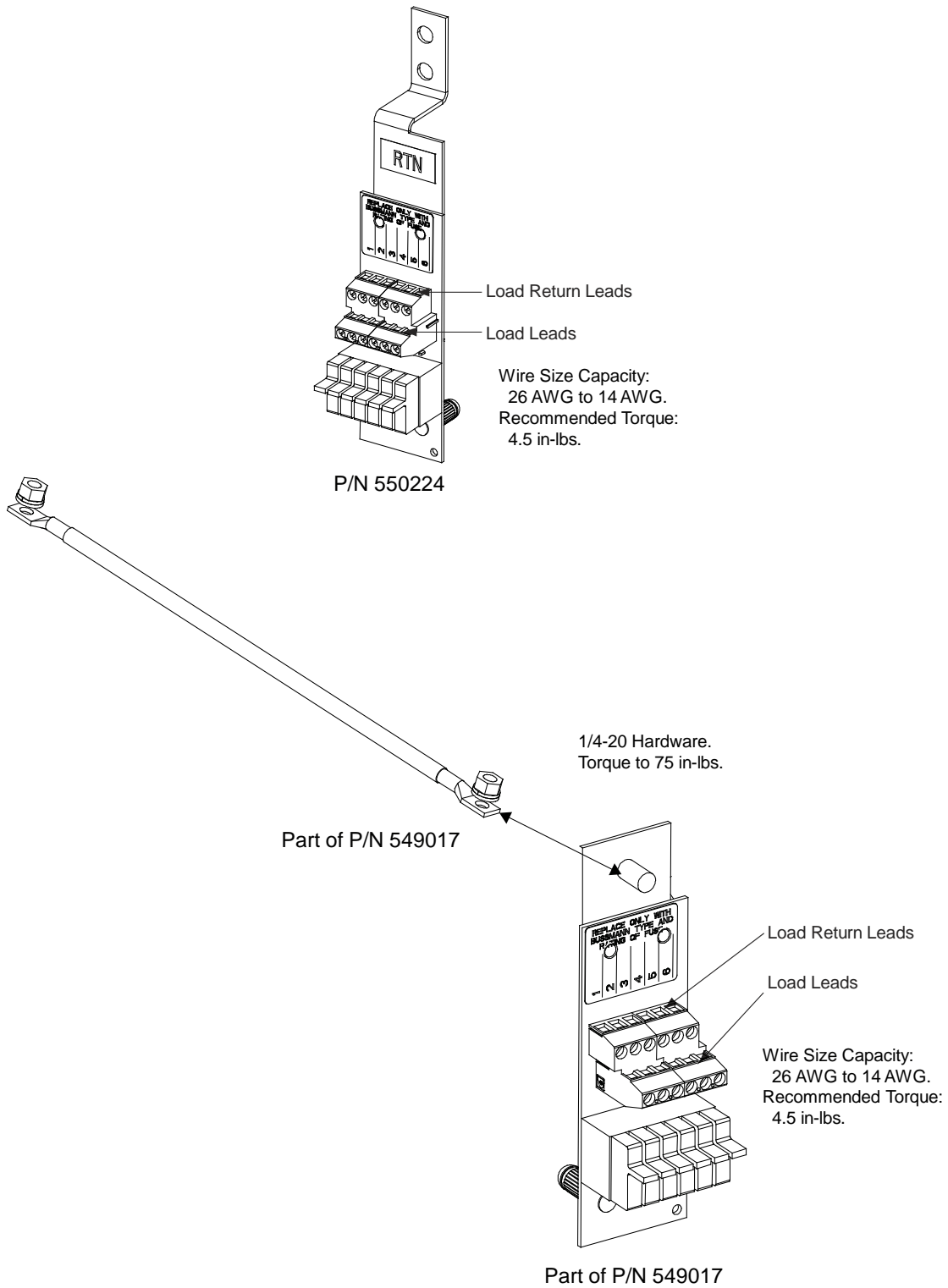

Battery Input

Battery Input Wire Sizes and Lugs Selection

- **When Distribution Panels Providing Battery Disconnect Fuse/Circuit Breaker Positions are Provided:** The rating of the disconnect device determines the input battery lead wire size requirement. The distribution panel ordered determines the lug hole size and spacing requirements. For wire size and lug selection; refer to the following.
 - a) **When Distribution Panels Using Bullet Nose Type Devices (TPS/TLS Fuses and/or Bullet Nose Type Circuit Breakers) are Provided:** Lug-terminated input battery leads are connected to the individual battery busbars and battery return busbar (if equipped) located on the distribution panel. If the distribution panel is not equipped with a battery return busbar, battery return connections are made to a separate return busbar.

The distribution panel's individual battery busbars and battery return busbar (if equipped) provide 1/4-20 studs for installation of customer-provided two-hole lugs that have 5/8 inch centers and 1/4 inch bolt clearance holes. Customer must provide (or order) lug mounting hardware. The distribution panel's individual battery busbars and return busbar (if equipped) are designed to accommodate the lugs listed in Table 8 and Table 10. Use Table 22 to select recommended battery wire sizes and lugs for various loop lengths per battery disconnect fuse/circuit breaker ampere rating. Maximum size of wire to be connected to a single fuseholder/circuit breaker position is 2 AWG. For wiring up to 350 kcmil, see Table 10 or see the following part numbers in ACCESSORY DESCRIPTIONS for available adapter busbars: [514717](#), [534449](#), and [514714](#).

The separate return busbar (if furnished) provides 3/8-16 captive nuts for installation of customer-provided two-hole lugs that have 1 inch centers and 3/8 inch bolt clearance holes. Customer must provide (or order) lug mounting bolts and hardware. The battery return busbar is designed to accommodate the lugs listed in Table 9. Use Table 23 to select recommended battery wire sizes and lugs for various loop lengths per battery disconnect fuse/circuit breaker ampere rating.
 - b) **When Distribution Panels Using GJ/218 Circuit Breakers, TPH Fuses, or TPL-B Fuses are Provided:** Lug-terminated battery leads are connected to the individual battery busbars and battery return busbar (if equipped) located on the distribution panel. If the distribution panel is not equipped with a battery return busbar, battery return connections are made to a separate return busbar.

The distribution panel's individual battery busbars and battery return busbar (if equipped) provide 3/8-16 captive nuts or studs for installation of customer-provided two-hole lugs that have 1 inch centers and 3/8 inch bolt clearance holes. Customer must provide (or order) lug mounting bolts (if required) and hardware. The distribution panel's individual battery busbars and battery return busbar are designed to accommodate the lugs listed in Table 9. Use Table 23 to select recommended battery wire sizes and lugs for various loop lengths per battery disconnect fuse/circuit breaker ampere rating.

The separate return busbar (if furnished) provides 3/8-16 captive nuts for installation of customer-provided two-hole lugs that have 1 inch centers and 3/8 inch bolt clearance holes. Customer must provide (or order) lug mounting bolts and hardware. The battery return busbar is designed to accommodate the lugs listed in Table 9. Use Table 23 to select recommended battery wire sizes and lugs for various loop lengths per battery disconnect fuse/circuit breaker ampere rating.
- **When Distribution Panels with Battery Disconnect Fuse/Circuit Breaker Positions are NOT Provided:** Lug-terminated input battery leads are connected to the battery busbar and battery return busbar. These busbars provide 3/8-16 captive nuts for installation of customer-provided two hole lugs that have 1 inch centers and 3/8 inch bolt clearance holes. Customer must provide lug mounting bolts and hardware. Battery wire size and lug requirements are determined by site requirements. For wire size and lug selection; refer to the following.

The battery busbars are designed to accommodate the lugs listed in Table 9. Use Table 23 to select recommended battery wire sizes and lugs for various loop lengths per required battery branch circuit ampere rating.

Battery Input Illustration

a) Connections to Lists 21 through 24 Distribution Cabinets

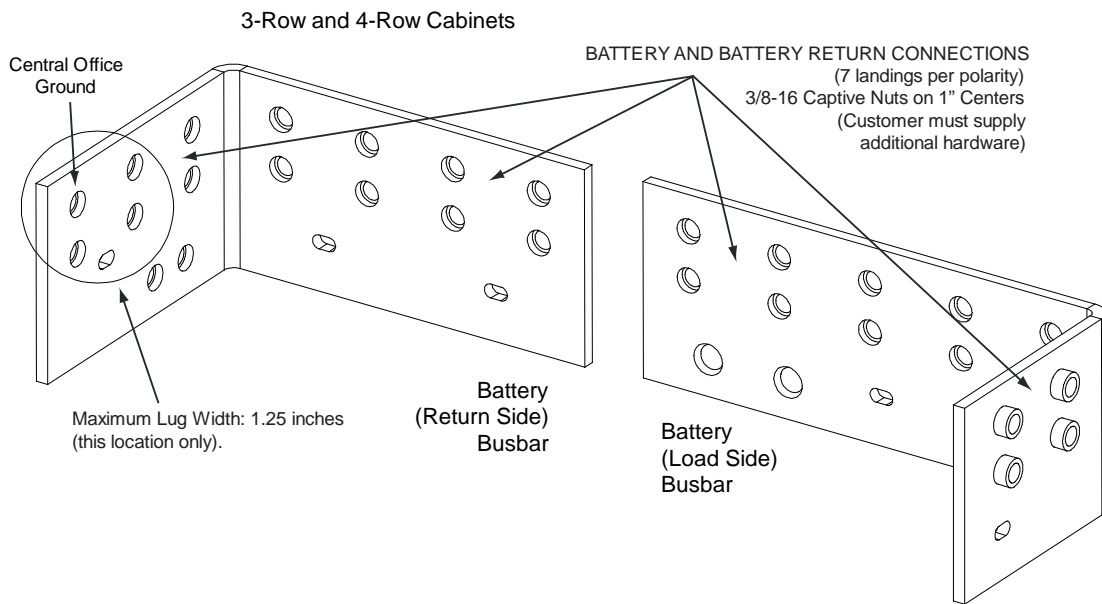
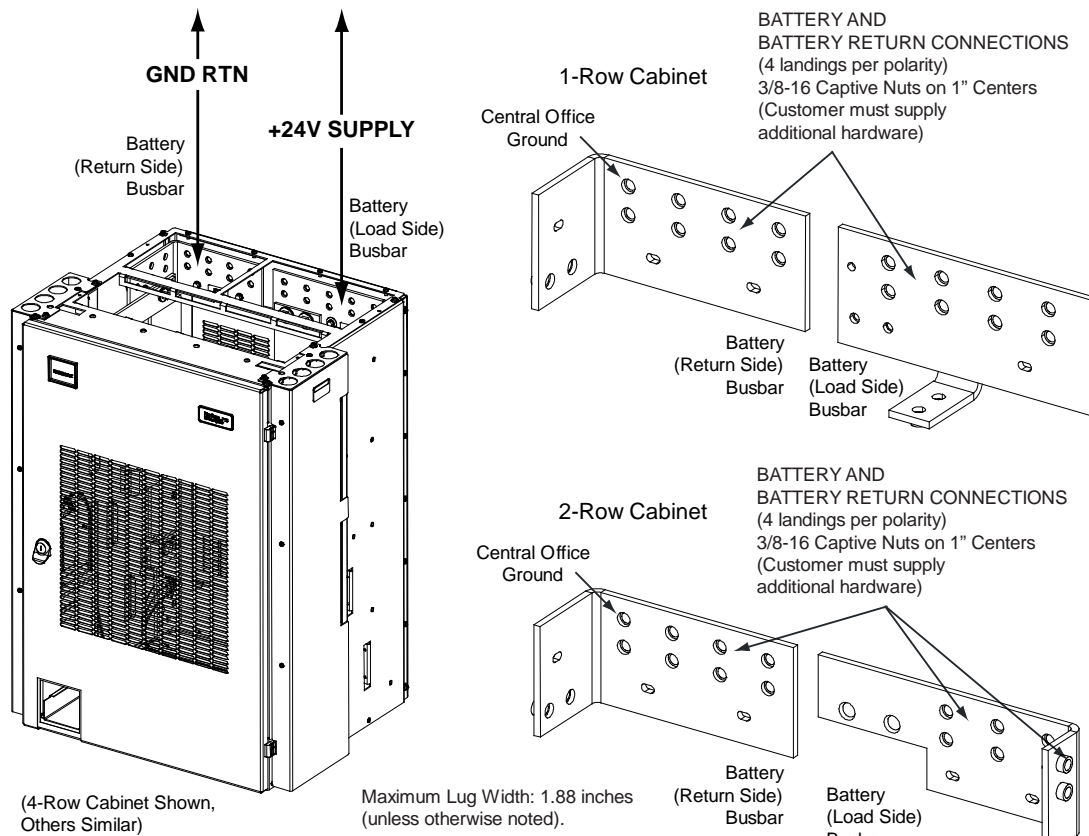

b) Connections to Battery Disconnect Circuit Breakers

Refer to the illustrations located under the Distribution Panel List descriptions in this document.

Vertiv™ NetSure™ 710NPBA DC Power System

System Application Guide

c) Connections to Optional Battery Busbar Extension Kit P/N 562364 Installed in a List 23 and List 24 Distribution Cabinet

Note: See *Battery Busbar Extension Kit (P/N 562364)* under *ACCESSORY DESCRIPTIONS* for description.

Note: Central Office Ground should be tied to any point on the battery return busbar or battery return extension busbar.

BATTERY BUSBAR
EXTENSION KIT P/N 562364
3/8" Clearance Holes
on 1" Centers
(Customer must supply
additional hardware)

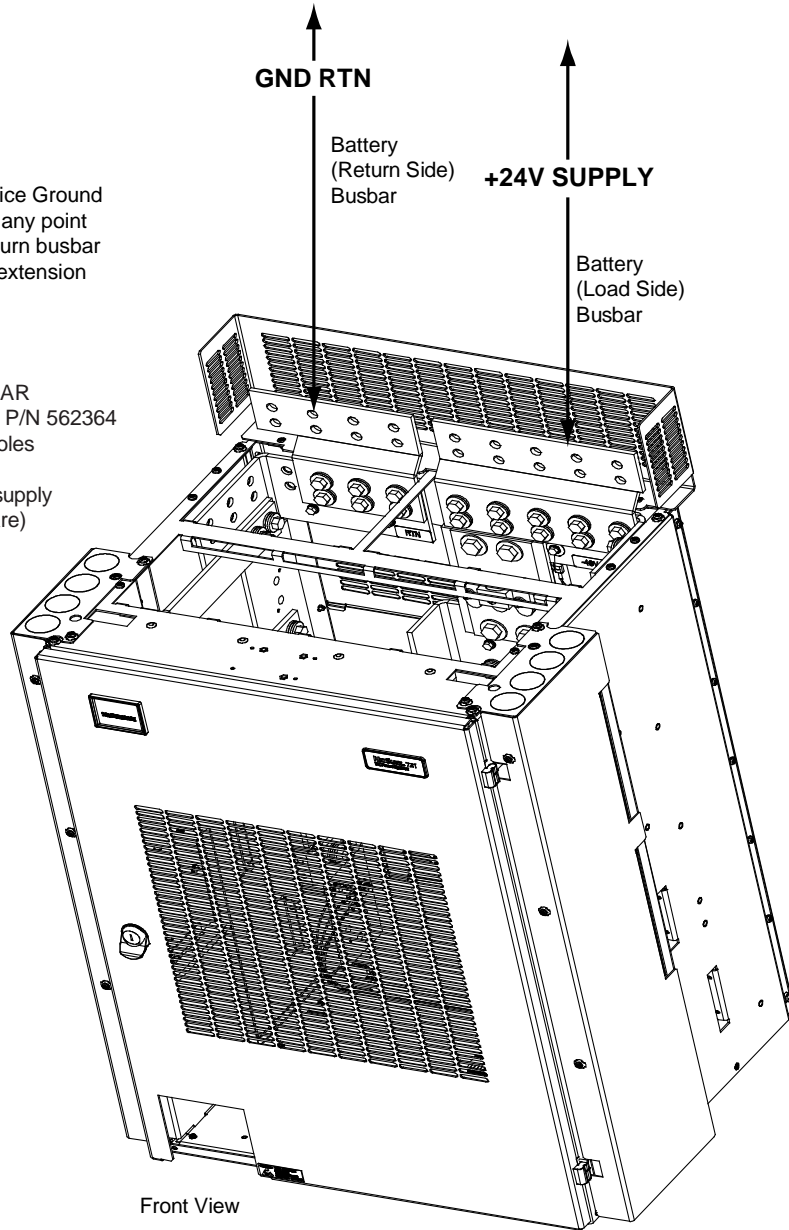

List 24 Distribution Cabinet
(List 23 Similar)

Vertiv™ NetSure™ 710NPBA DC Power System

System Application Guide

d) Connections to Optional Battery Landing Busbar Kit P/N 553584 Installed in List 21 Distribution Cabinet

Note: See *Battery Busbar Extension Kit (P/N 553584)* under *ACCESSORY DESCRIPTIONS* for description.

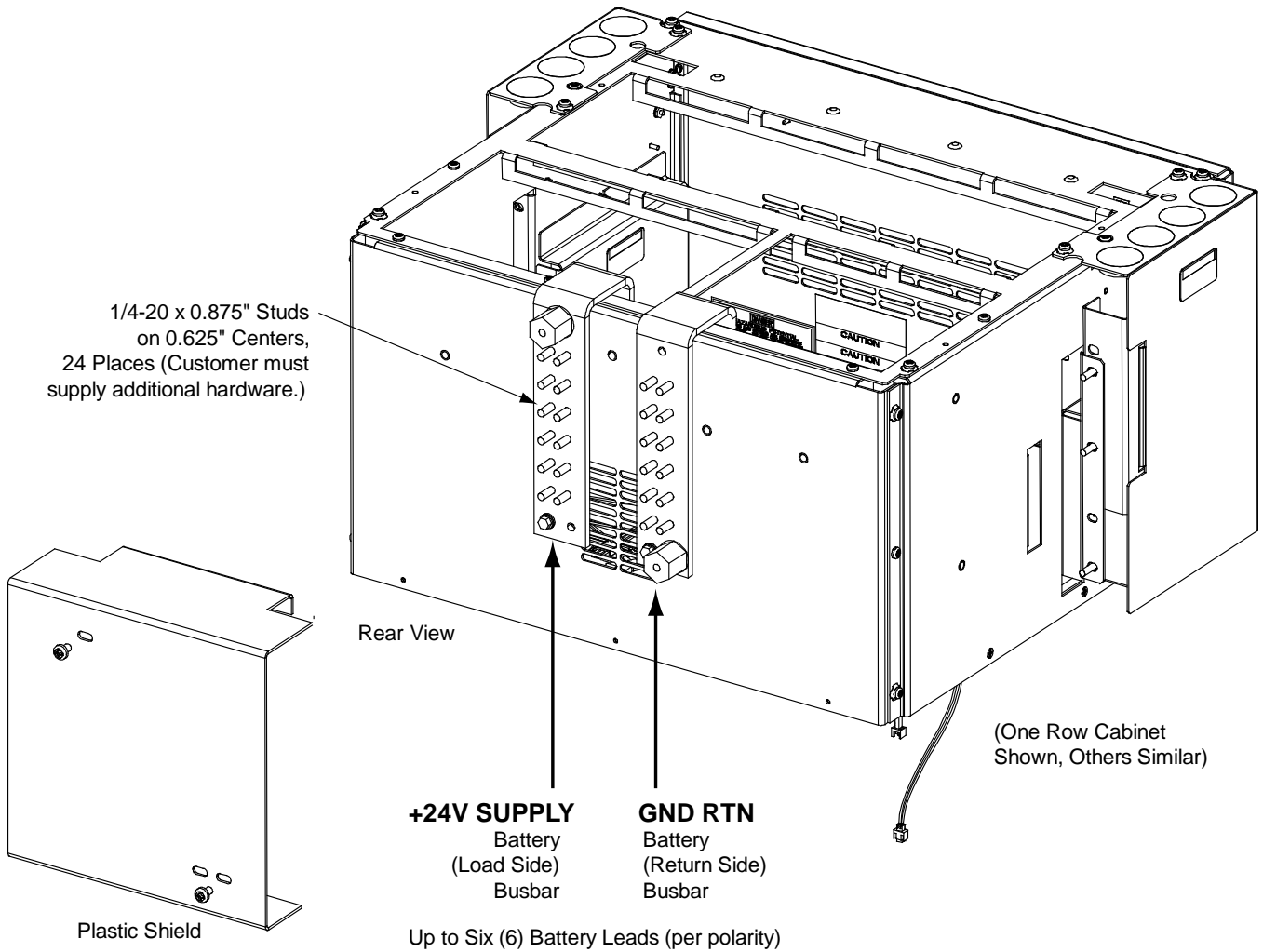

Vertiv™ NetSure™ 710NPBA DC Power System

System Application Guide

e) Connections to Optional Battery Landing Busbar Kit P/N 555478 Installed in Lists 22 through 24 Distribution Cabinets

Note: See Battery Busbar Extension Kit (P/N 555478) under ACCESSORY DESCRIPTIONS for description.

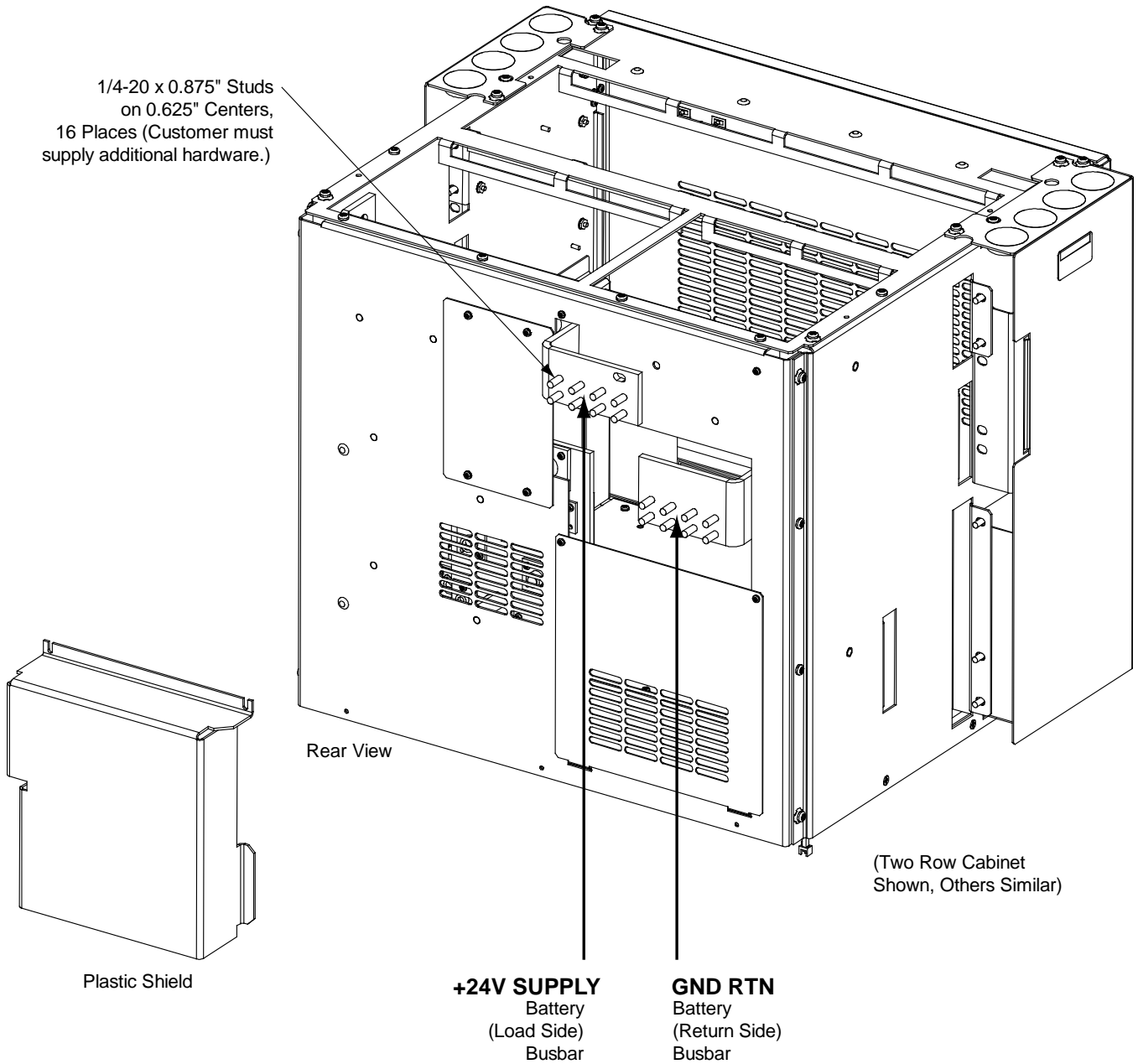

Up to Eight (8) Battery Leads (per polarity).
[Four (4) battery landing positions, two (2) battery cable lugs back-to-back each position.]

**Wire Size and Lug Selection Tables for Load and Battery Connections
to TPS/TLS Fuses and Bullet Nose Type Circuit Breakers**

Fuse/ Circuit Breaker Amperage	Recm 90°C Wire Size ⁽¹⁾							
	14 AWG	12 AWG	10 AWG	8 AWG	6 AWG	4 AWG	2 AWG	1/0 AWG
	Loop Length (feet) ⁽²⁾							
1, 3, 5, 6, 10 A	37 ^(3,4)	58 ^(3,4)	93 ^(3,4)	--	--	--	--	--
15 A	24 ^(3,4)	39 ^(3,4)	62 ^(3,4)	--	--	--	--	--
20 A	--	29 ^(3,4)	46 ^(3,4)	74 ^(3,4)	--	--	--	--
25 A	--	--	37 ^(3,4)	59 ^(3,4)	94 ^(3,4)	--	--	--
30 A	--	--	31 ^(3,4)	49 ^(3,4)	78 ^(3,4)	--	--	--
35 A	--	--	--	42 ^(3,4)	67 ^(3,4)	107 ^(3,4)	--	--
40 A	--	--	--	37 ^(3,4)	59 ^(3,4)	94 ^(3,4)	--	--
45 A	--	--	--	33 ^(3,4)	52 ^(3,4)	83 ^(3,4)	--	--
50 A	--	--	--	29 ^(3,4)	47 ^(3,4)	75 ^(3,4)	--	--
60 A	--	--	--	--	39 ^(3,4)	62 ^(3,4)	99 ^(3,4)	--
70 A	--	--	--	--	33 ⁽³⁾	53 ^(3,4)	85 ^(3,4)	135 ⁽⁴⁾
75 A	--	--	--	--	31 ⁽³⁾	50 ^(3,4)	79 ^(3,4)	126 ⁽⁴⁾
80 A	--	--	--	--	--	47 ^(3,4)	74 ^(3,4)	118 ^(3,4)
Recommended Crimp Lug ⁽⁵⁾								
Lug	245342300	245342300	245342300	245390200	245346700	245346800	245346900	245393500 ⁽⁶⁾

- ¹ Wire sizes based on recommendations of the American National Standards Institute (ANSI) approved National Fire Protection Association's (NFPA) National Electrical Code (NEC). Table 310-16 for copper wire at 90 °C conductor temperature operating in ambients of 30°C and 40°C was used. For other operating ambient temperatures, refer to the NEC. For operation in countries where the NEC is not recognized, follow applicable codes.
- ² Recommended wire sizes are sufficient to restrict voltage drop to 1.0 volt or less at listed branch current for the loop lengths shown. Loop length is the sum of the lengths of the positive and negative leads.
- ³ Wire Size / Loop Length Combination Calculated using 30 °C Ambient Operating Temperature.
- ⁴ Wire Size / Loop Length Combination Calculated using 40 °C Ambient Operating Temperature.
- ⁵ Two-hole lug, 1/4" bolt clearance hole, 5/8" centers. Lugs should be crimped per lug manufacturer's specifications.
- ⁶ Special application crimp lug / strap combination.

Table 22 (cont'd on next page)
Recommended Wire Sizes and Lugs for Load and Battery Connections
to Various TPS/TLS Fuses and Bullet Nose Type Circuit Breakers

Vertiv™ NetSure™ 710NPBA DC Power System
System Application Guide

Fuse/ Circuit Breaker Amperage	Recm 90°C Wire Size ⁽¹⁾							
	4 AWG	2 AWG	1/0 AWG	2/0 AWG	3/0 AWG	4/0 AWG	250 kcmil	350 kcmil
	Loop Length (feet) ⁽²⁾							
90 A	41 ⁽³⁾	66 ^(3,4)	105 ^(3,4)	133 ⁽⁴⁾	--	--	--	--
100 A	--	59 ^(3,4)	95 ^(3,4)	119 ^(3,4)	--	--	--	--
125 A	--	47 ⁽³⁾	76 ^(3,4)	95 ^(3,4)	120 ⁽⁴⁾	--	--	--
150 A	--	--	63 ^(3,4)	79 ^(3,4)	100 ^(3,4)	--	--	--
200 A	--	--	--	--	75 ^(3,4)	95 ^(3,4)	112 ^(3,4)	--
250 A	--	--	--	--	--	76 ^(3,4,7)	90 ^(3,4,7)	126 ^(3,4,7)
300 A	--	--	--	--	--	--	--	105 ^(3,4,7)
Recommended Crimp Lug								
Lug ⁽⁵⁾	245346800	245346900	245393500 ⁽⁶⁾	245393600 ⁽⁶⁾	245393700 ⁽⁶⁾	245393800 ⁽⁶⁾	514872 ⁽⁶⁾	514873 ⁽⁶⁾
Lug ^(8,9)	--	245348200	245347100	245347200	245347300	245347400	245347500	245347700

- ¹ Wire sizes based on recommendations of the American National Standards Institute (ANSI) approved National Fire Protection Association's (NFPA) National Electrical Code (NEC). Table 310-16 for copper wire at 90 °C conductor temperature operating in ambients of 30°C and 40°C was used. For other operating ambient temperatures, refer to the NEC. For operation in countries where the NEC is not recognized, follow applicable codes.
- ² Recommended wire sizes are sufficient to restrict voltage drop to 1.0 volt or less at listed branch current for the loop lengths shown. Loop length is the sum of the lengths of the positive and negative leads.
- ³ Wire Size / Loop Length Combination Calculated using 30 °C Ambient Operating Temperature.
- ⁴ Wire Size / Loop Length Combination Calculated using 40 °C Ambient Operating Temperature.
- ⁵ Two-hole lug, 1/4" bolt clearance hole, 5/8" centers. Lugs should be crimped per lug manufacturer's specifications.
- ⁶ Special application crimp lug / strap combination.
- ⁷ **MUST USE** P/N 514717 Lug Adapter Busbar for lugs having 1/4" bolt clearance hole, 5/8" centers.
- ⁸ Two-hole lug, 3/8" bolt clearance hole, 1" centers. Lugs should be crimped per lug manufacturer's specifications.
- ⁹ **MUST USE** P/N 534449 Lug Adapter Busbar Kit for 125 A to 200 A circuit breakers or P/N 514714 Lug Adapter Busbar Kit for 225 A to 300 A circuit breakers.

Table 22 (cont'd from previous page)
Recommended Wire Sizes and Lugs for Load and Battery Connections
to Various TPS/TLS Fuses and Bullet Nose Type Circuit Breakers

**Wire Size and Lug Selection Tables for Load and Battery Connections
to TPH Fuses, TPL-B Fuses, and GJ/218 Type Circuit Breakers or Battery Branch Circuits**

Fuse/ Circuit Breaker Amperage	Recm 90°C Wire Size ⁽¹⁾							
	6 AWG	4 AWG	2 AWG	1/0 AWG	2/0 AWG	3/0 AWG	4/0 AWG	250 kcmil
	Loop Length (feet) ⁽²⁾							
70 A	33 ⁽³⁾	53 ^(3,4)	85 ^(3,4)	135 ⁽⁴⁾	--	--	--	--
80 A	--	47 ^(3,4)	74 ^(3,4)	118 ^(3,4)	--	--	--	--
100 A	--	--	59 ^(3,4)	95 ^(3,4)	119 ^(3,4)	--	--	--
125 A	--	--	47 ⁽³⁾	76 ^(3,4)	95 ^(3,4)	120 ⁽⁴⁾	--	--
150 A	--	--	--	63 ^(3,4)	79 ^(3,4)	100 ^(3,4)	--	--
175 A	--	--	--	--	68 ^(3,4)	86 ^(3,4)	108 ^(3,4)	--
200 A	--	--	--	--	--	75 ^(3,4)	95 ^(3,4)	112 ^(3,4)
Recommended Crimp Lug ⁽⁵⁾								
Lug	245349900	245350000	245348200	245347100	245347200	245347300	245347400	245347500

- ¹ Wire sizes based on recommendations of the American National Standards Institute (ANSI) approved National Fire Protection Association's (NFPA) National Electrical Code (NEC). Table 310-16 for copper wire at 90 °C conductor temperature operating in ambients of 30°C and 40°C was used. For other operating ambient temperatures, refer to the NEC. For operation in countries where the NEC is not recognized, follow applicable codes.
- ² Recommended wire sizes are sufficient to restrict voltage drop to 1.0 volt or less at listed branch current for the loop lengths shown. Loop length is the sum of the lengths of the positive and negative leads.
- ³ Wire Size / Loop Length Combination Calculated using 30 °C Ambient Operating Temperature.
- ⁴ Wire Size / Loop Length Combination Calculated using 40 °C Ambient Operating Temperature.
- ⁵ Two-hole lug, 3/8" bolt clearance hole, 1" centers. Lugs should be crimped per lug manufacturer's specifications.

Table 23 (cont'd on next page)
Recommended Wire Sizes and Lugs for Load and Battery Connections
to Various TPH Fuses, TPL-B Fuses, and GJ/218-Circuit Breakers
or Battery Branch Circuits

Vertiv™ NetSure™ 710NPBA DC Power System
System Application Guide

Fuse/ Circuit Breaker Amperage	Recm 90°C Wire Size ⁽¹⁾							
	2/0 AWG	3/0 AWG	4/0 AWG	250 kcmil	300 kcmil	350 kcmil	400 kcmil	500 kcmil
	Loop Length (feet) ⁽²⁾							
225 A	--	67 ⁽³⁾	84 ^(3,4)	100 ^(3,4)	120 ⁽⁴⁾	--	--	--
250 A	--	--	76 ⁽³⁾	90 ^(3,4)	108 ^(3,4)	126 ⁽⁴⁾	--	--
300 A	159 ⁽⁴⁾ (2) Wires	--	--	--	90 ⁽³⁾	105 ^(3,4)	120 ^(3,4)	--
400 A	--	75 ^(3,4) (2) Wires	95 ^(3,4) (2) Wires	112 ^(3,4) (2) Wires	--	--	--	--
500 A	--	--	76 ⁽³⁾ (2) Wires	90 ^(3,4) (2) Wires	108 ^(3,4) (2) Wires	126 ⁽⁴⁾ (2) Wires	--	--
600 A	--	--	--	--	90 ⁽³⁾ (2) Wires	105 ^(3,4) (2) Wires 157 ⁽⁴⁾ (3) Wires	120 ^(3,4) (2) Wires	--
800 A	--	--	--	84 ⁽³⁾ (3) Wires	101 ^(3,4) (3) Wires	118 ^(3,4) (3) Wires	135 ^(3,4) (3) Wires	--
Recommended Crimp Lug ⁽⁵⁾								
Lug	245347200 (per cable)	245347300 (per cable)	245347400 (per cable)	245347500 (per cable)	245347600 (per cable) See also Note 6.	245347700 (per cable) See also Note 6.	245347800 (per cable) See also Note 6.	245347900 (per cable)

- ¹ Wire sizes based on recommendations of the American National Standards Institute (ANSI) approved National Fire Protection Association's (NFPA) National Electrical Code (NEC). Table 310-16 for copper wire at 90 °C conductor temperature operating in ambients of 30°C and 40°C was used. For other operating ambient temperatures, refer to the NEC. For operation in countries where the NEC is not recognized, follow applicable codes.
- ² Recommended wire sizes are sufficient to restrict voltage drop to 1.0 volt or less at listed branch current for the loop lengths shown. Loop length is the sum of the lengths of the positive and negative leads.
- ³ Wire Size / Loop Length Combination Calculated using 30 °C Ambient Operating Temperature.
- ⁴ Wire Size / Loop Length Combination Calculated using 40 °C Ambient Operating Temperature.
- ⁵ Two-hole lug, 3/8" bolt clearance hole, 1" centers. Lugs should be crimped per lug manufacturer's specifications.
- ⁶ For a 600 A GJ/218 circuit breaker installed in a List AM or List AP distribution panel, P/N 562888 3-pole lug adapter may be ordered. P/N 562888 includes one (1) busbar that mounts on the three lug landing positions of a 600 A circuit breaker installed in a List AM or List AP distribution panel and one (1) busbar that mounts on the three landings of the associated ground return bar. These busbars provide two (2) landings for standard two-hole lugs having 3/8" bolt clearance holes on 1" centers.

Table 23 (cont'd from previous page)
Recommended Wire Sizes and Lugs for Load and Battery Connections
to Various TPH Fuses, TPL-B Fuses, GJ/218-Circuit Breakers
or Battery Branch Circuits

SPECIFICATIONS

1. SYSTEM

1.1 Output Ratings

1.1.1 See “General Specifications” starting on page 2.

1.2 Input Ratings

1.2.1 See “General Specifications” starting on page 2.

1.3 Environmental Ratings

1.3.1 Operating Ambient Temperature Range: -40 °C to +40 °C (-40 °F to +104 °F).

1.3.2 Storage Ambient Temperature Range: -40 °C to +85 °C (-40 °F to +185 °F).

1.3.3 Humidity: This Power System is capable of operating in an ambient relative humidity range of 0% to 95%, non-condensing.

1.3.4 Altitude: Capable of operating in an altitude range of -200 feet to 10,000 feet. The maximum operating ambient temperature should be de-rated by 3 °C per 1000 feet above 5000 feet.

1.3.5 Mounting: Refer to “Overall Dimensions” on page 113 for mounting dimensions.

- This product is intended only for installation in a restricted access location on or above a non-combustible surface.
- This product must be located in a controlled environment with access to crafts persons only.
- This product is intended for installation in network telecommunication facilities (CO, vault, hut, or other environmentally controlled electronic equipment enclosure).
- This product is intended to be connected to the common bonding network in a network telecommunication facility (CO, vault, hut, or other environmentally controlled electronic equipment enclosure).
- The DC return connection to this system can remain isolated from system frame and chassis (DC-I).
- Rectifier, converter, and mounting shelf ventilating openings must not be blocked and temperature of air entering rectifiers and converters must not exceed the rated operating ambient temperature range.
- Clearance requirements are:
 - a) Recommended minimum aisle space clearance for the front of each bay is 2'6".
 - b) Recommended minimum aisle space clearance for the rear of each bay is 2'0" for any of the following conditions:
 - 1) Addition of a module mounting shelf in the field.
 - 2) Adding battery tray(s) in the field.
 - 3) Any bay equipped with List A1 or A2 Inverters, or List D2 or D3 DC-DC Converters.
 - c) For all other conditions, required minimum spacing from the rear of the bay to a wall or other solid surface is that which is specified for proper module mounting shelf ventilation. Refer to the specific module mounting shelf Power Data Sheet or System Application Guide for ventilation spacing requirements.

Note: Minimum spacing specified for ventilation may not permit replacement of certain components such as busbars or module mounting shelves.

1.4 Compliance Information

1.4.1 Safety Compliance: This power board is UL Listed (“c UL”) as a DC Power Distribution Center for Communications Equipment. This unit meets the requirements of CSA 22.2, No. 225 and is tested and Certified by UL (“c UL”) as a Custom Built Power Distribution Center for Communications Equipment.

1.4.2 NEBS Compliance: Compliance verified by a Nationally Recognized Testing Laboratory (NRTL) per GR-1089-CORE and GR-63-CORE. Contact Vertiv for NEBS compliance reports.

Rectifier Modules: In order to remain compliant during a fan failure condition, the backup battery connection must be utilized to provide sufficient power to the loads for up to eight (8) hours when the system is operated at greater than 50% output power. If no backup battery connection is used, the system must operate with a redundant module installed.

Converter Modules: In order to remain compliant during a fan failure condition, the system must operate with a redundant module installed.

Vertiv™ NetSure™ 710NPBA DC Power System

System Application Guide

- 1.5 IB2 and EIB (Controller Interface Board) Ratings
 - 1.5.1 Digital Input Ratings
 - (A) Maximum Voltage Rating: 60 VDC.
 - (B) Active High: > 19 VDC.
 - (C) Active Low: < 1 VDC.
 - 1.5.2 Relay Ratings
 - (A) Steady State: 0.5 A @ 60 VDC; 1.0 A @ 30 VDC.
 - (B) Peak: 3 A @ 30 VDC.
- 2. MODULE MOUNTING ASSEMBLY
Refer to PD588705200 (PD588705201, PD588705202, PD588705203, PD588705204).
- 3. RECTIFIER
Refer to the Rectifier Instructions (UM1R243000).
- 4. CONVERTER
Refer to the Converter Instructions (UM1C24481500).
- 5. CONTROLLER
Refer to the ACU+ Controller User Instructions (UM1M820BNA) or NCU Controller Instructions (UM1M830BNA).
For controller factory settings, refer to the Controller Configuration Drawing (C-drawing).
- 6. LIST A1 AND LIST A2 INVERTER
For List A1 and List A2 inverter specifications, refer to the separate inverter instruction manuals furnished with the Inverters.
- 7. LIST D2 AND D3 DC-DC CONVERTER
For List D2 and D3 DC-DC Converter specifications, refer to the separate DC-DC Converter instruction manuals furnished with the Converters.

MECHANICAL SPECIFICATIONS

Overall Dimensions

Refer to PD588705200 (PD588705201, PD588705202, PD588705203, PD588705204) for module mounting assembly dimensions.

◆ Refer to Table 7 for relay rack dimensions.

List 21 (One-Row Distribution Cabinet)

Notes:

1. All dimensions are in inches, unless otherwise specified.
2. Finish: Textured Gray

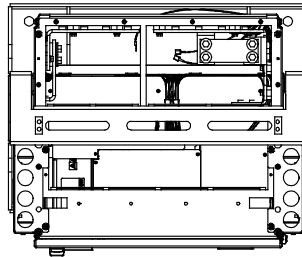

Top View

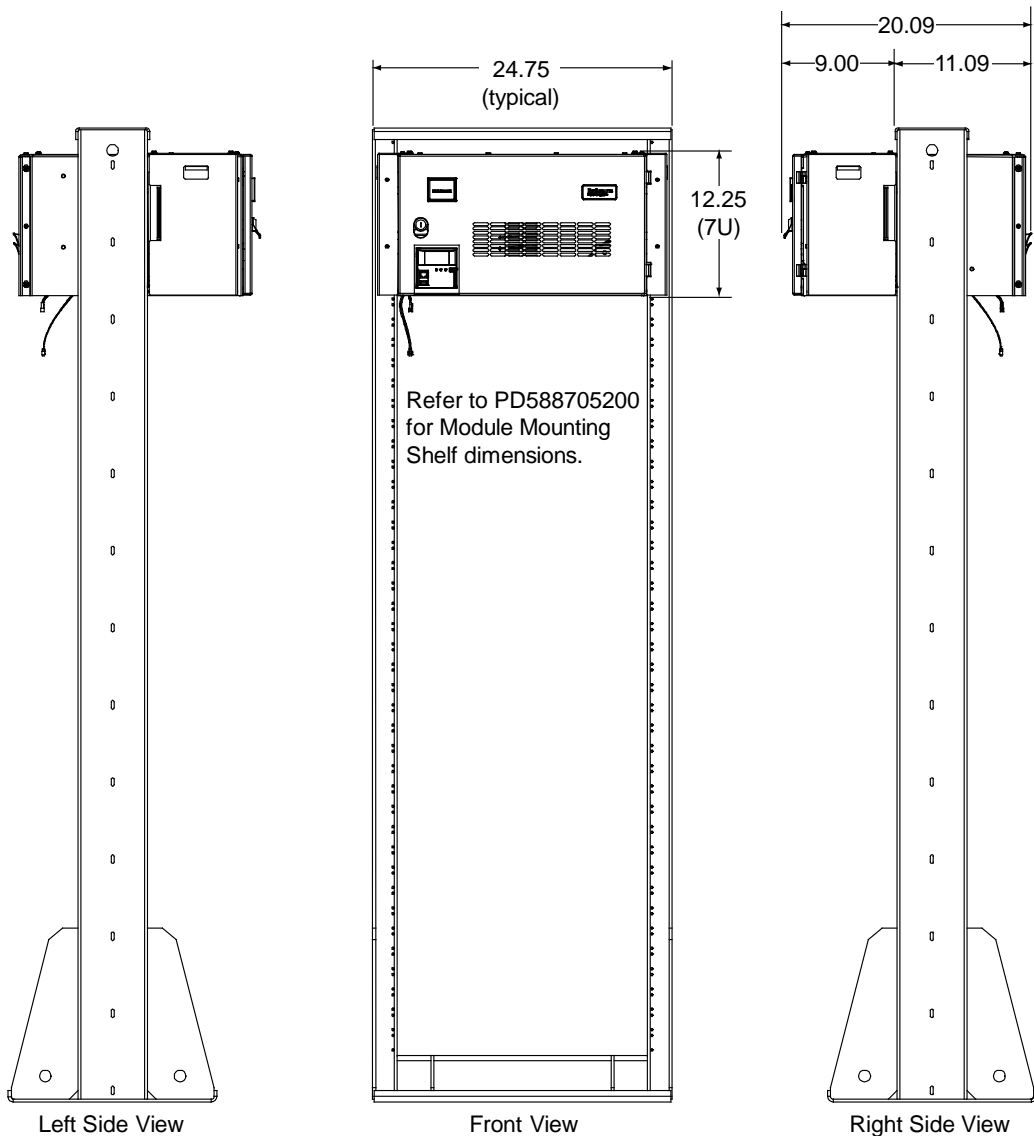

Left Side View

Front View

Right Side View

Vertiv™ NetSure™ 710NPBA DC Power System

System Application Guide

List 22 (Two-Row Distribution Cabinet)

Notes:

1. All dimensions are in inches, unless otherwise specified.
2. Finish: Textured Gray

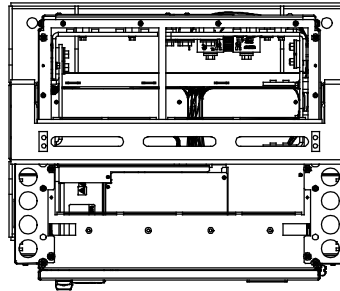

Top View

Optional List CB or CC
Low Voltage Battery
Disconnect

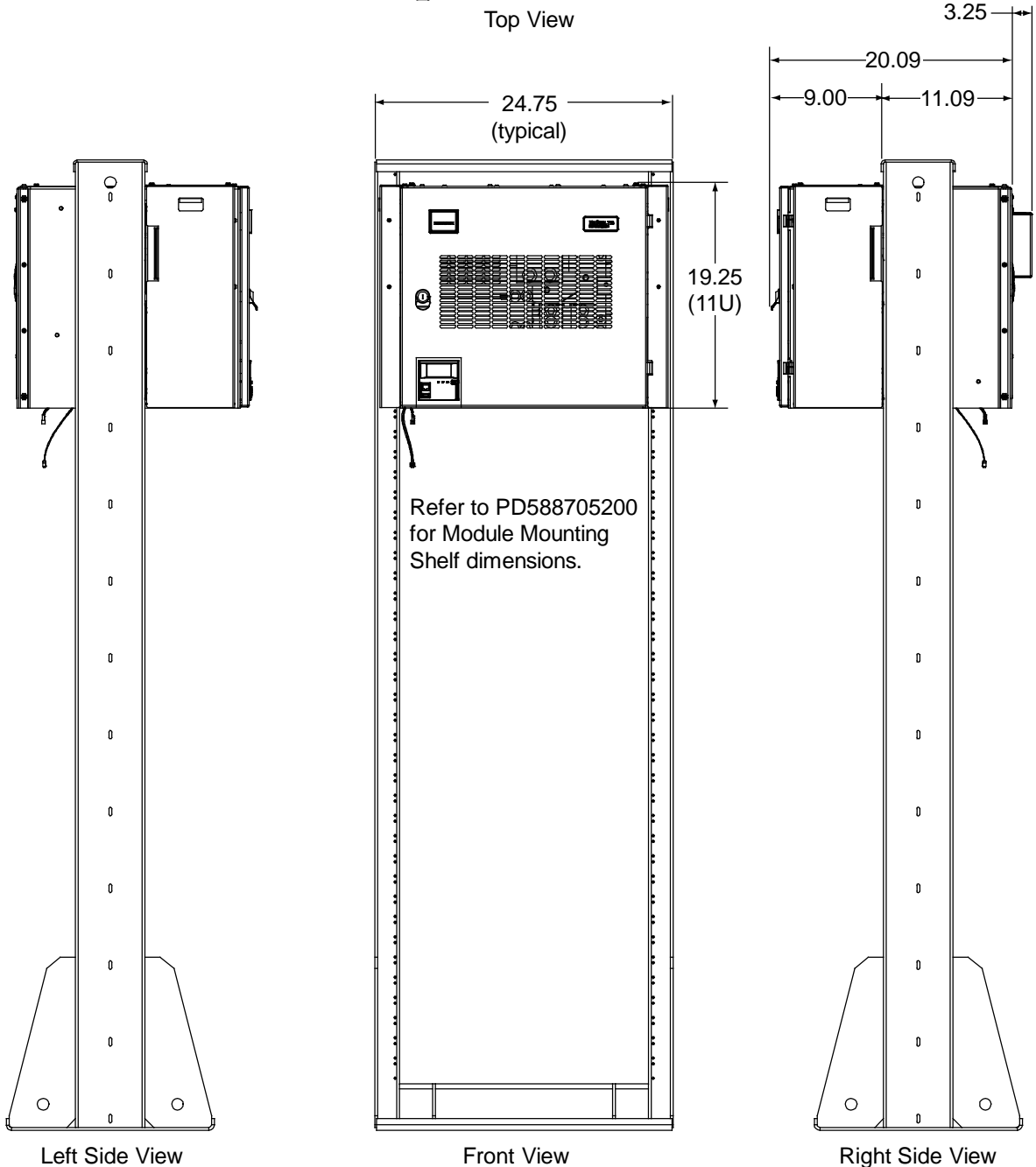

Vertiv™ NetSure™ 710NPBA DC Power System
System Application Guide

List 23 (Three-Row Distribution Cabinet)

Notes:

1. All dimensions are in inches, unless otherwise specified.
2. Finish: Textured Gray

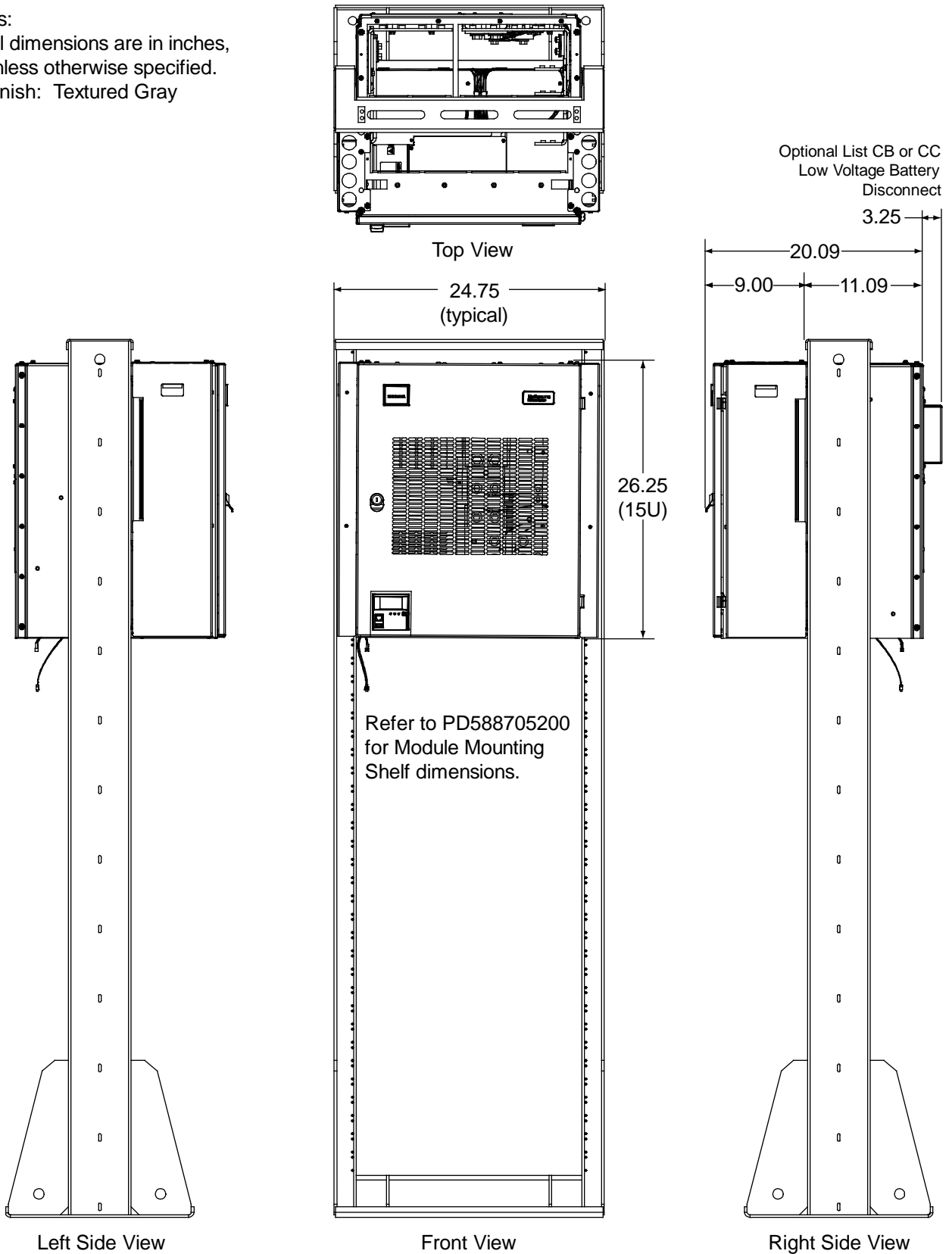

Vertiv™ NetSure™ 710NPBA DC Power System
System Application Guide

List 24 (Four-Row Distribution Cabinet)

Notes:

1. All dimensions are in inches, unless otherwise specified.
2. Finish: Textured Gray

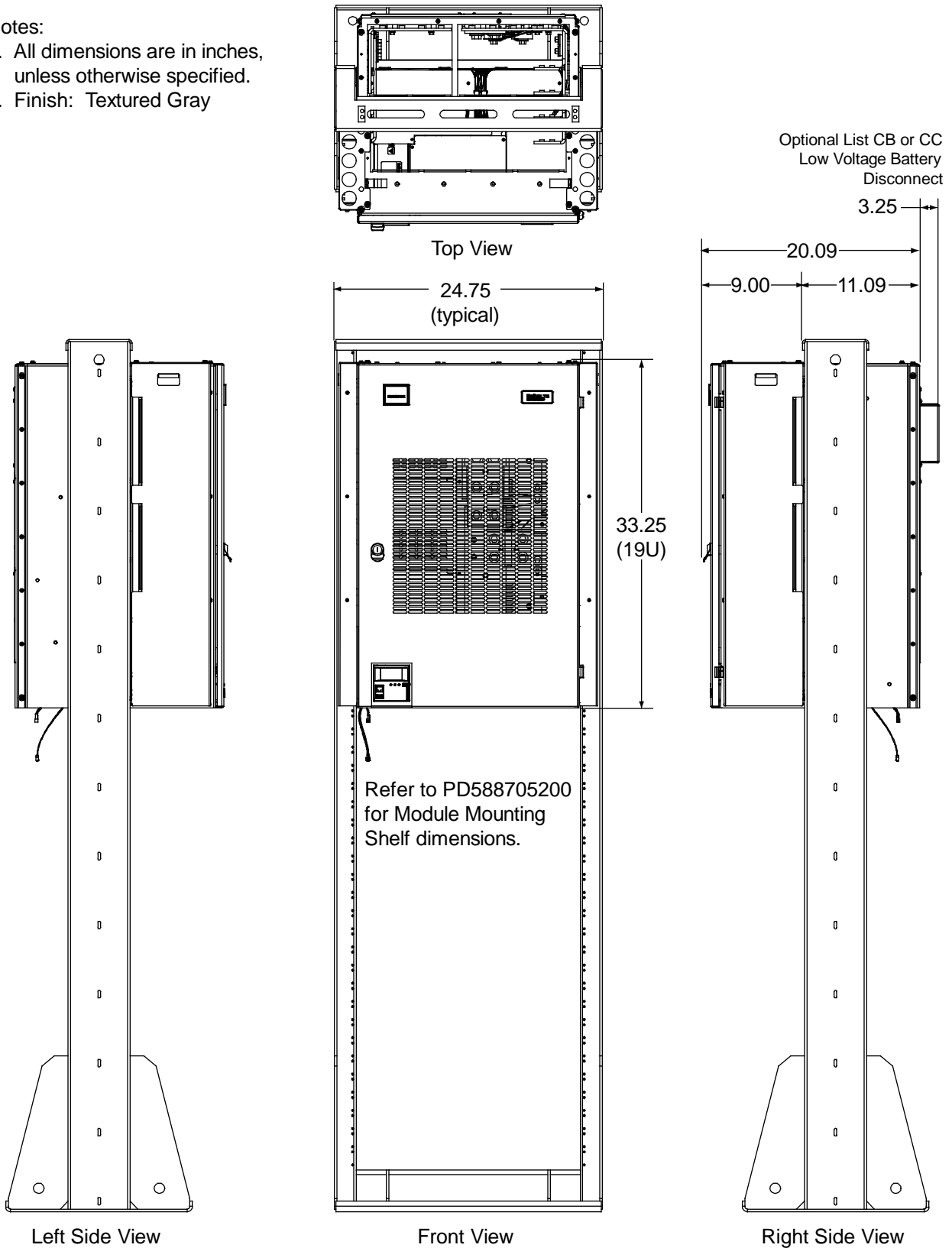

List 93 (Battery Tray)

Notes:

1. All dimensions are in inches, unless otherwise specified.
2. Finish: Textured Gray
3. Maximum trays available per rack is four (4).

Optional Battery Disconnect Circuit Breakers
 (Mounted on Both Side)

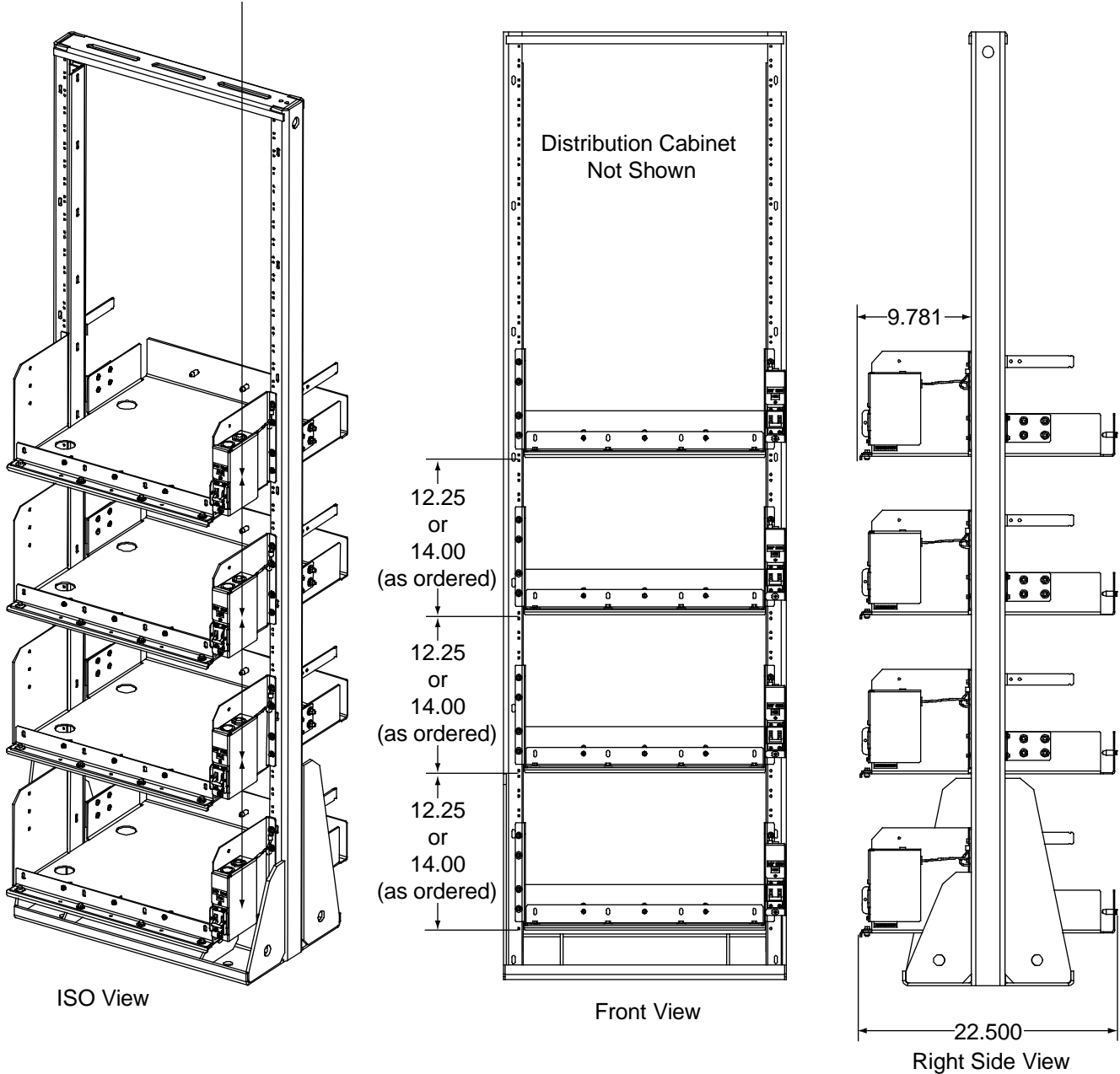

Vertiv™ NetSure™ 710NPBA DC Power System

System Application Guide

Dimensions (Arrangement of System Configured with Lists A1, A2, D2, D3)

Notes:

1. All dimensions are in inches.
2. Finish: Textured Gray

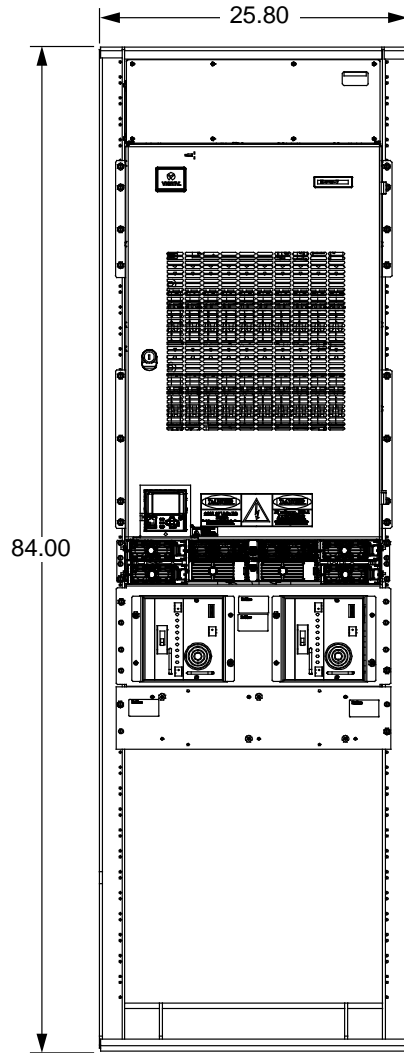

Front View

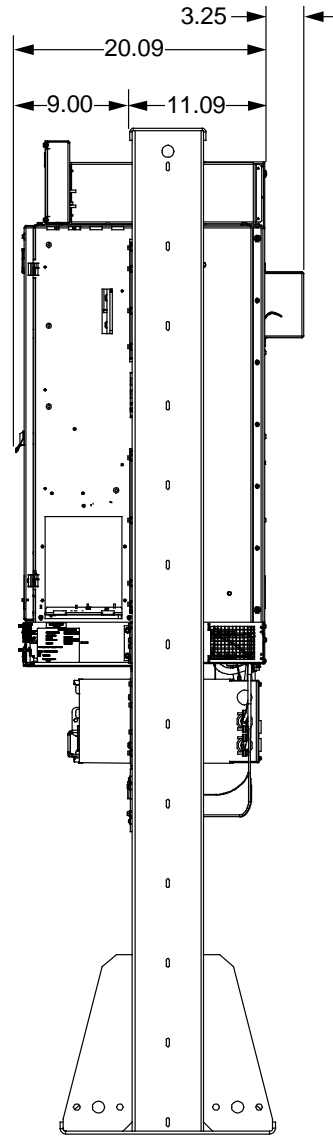

Right Side View

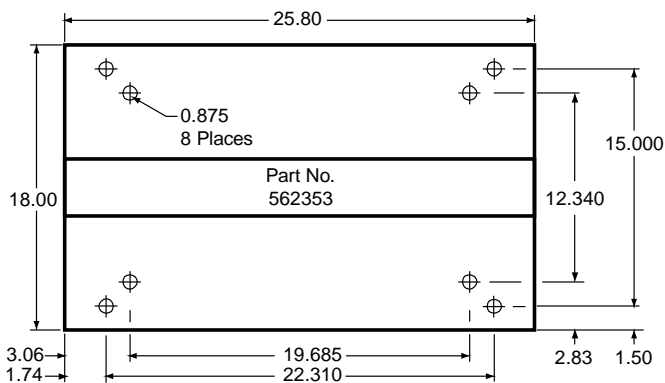

Relay Rack Floor Mounting Dimensions

Four (4) 1.10-inch conduit knockouts provided for nominal 3/4-inch conduit.

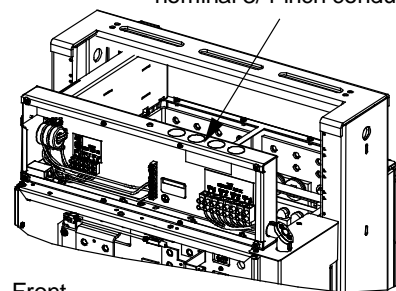

Front
(front cover removed)

Vertiv™ NetSure™ 710NPBA DC Power System
System Application Guide

Weights

List Number or Part Number	Net Weight (lbs), each	Description
Common Equipment		
58112700001	2	Bay Common Equipment
Distribution Cabinets		
58112700021	55	Distribution Cabinet, 1 Row
58112700022	76	Distribution Cabinet, 2 Rows
58112700023	98	Distribution Cabinet, 3 Rows
58112700024	126	Distribution Cabinet, 4 Rows
Module Mounting Shelf		
588705200 588705201	26	Module Mounting Shelf
588705202	50	Module Mounting Shelf
588705203	74	Module Mounting Shelf
588705204	98	Module Mounting Shelf
1R243000 1R242500	6.4	Rectifier
1C24481500	5.5	Converter
Inverter System		
581127000A1	30	Inverter, 120 VAC, 60 Hz, 1 KVA Hardwired Output (Includes Wireway, Input Terminations, and Mounting Panel for Two Inverters)
581127000A2	10	Inverter, 120 VAC, 60 Hz, 1 KVA Receptacle Output
Converter System		
581127000D2	5	+24 V to -24 V, 6.25 A DC-DC Converter
581127000D3	5	+24 V to +12 V, 8 A DC-DC Converter
Battery Accessories		
58112700090	1.5	Battery Shunt, 800 A
58112700091	3.5	Battery Shunt, 2000 A
58112700092	3.2	Battery Shunt, 2500 A
58112700093	32	Integrated, Pre-cabled Battery Tray
528500 528501	1	Battery Disconnect Breaker Kit, 1-pole
528502 528503	1.5	Battery Disconnect Breaker Kit, 2-pole
Distribution Panels, Primary Voltage		
581127000AA	12	Distribution Panel
581127000AB	9	Distribution Panel
581127000AC	6	Distribution Panel
581127000AD	5	Distribution Panel
581127000AE	13	Distribution Panel
581127000AF	16	Distribution Panel
581127000AG	16	Distribution Panel
581127000AH	22	Distribution Panel

Vertiv™ NetSure™ 710NPBA DC Power System
System Application Guide

List Number or Part Number	Net Weight (lbs), each	Description
581127000AJ	11	Distribution Panel
581127000AK	13	Distribution Panel
581127000AL	12.6	Distribution Panel
581127000AM	17	Distribution Panel
581127000AN	9.6	Distribution Panel
581127000AP	8	Distribution Panel
Distribution Panels, Dual Voltage		
581127000DA	12.5	Distribution Panel
581127000DB	12.5	Distribution Panel
581127000DC	12.5	Distribution Panel
581127000DD	12.5	Distribution Panel
581127000DE	14	Distribution Panel
581127000DF	14	Distribution Panel
581127000DG	14	Distribution Panel
581127000DH	14	Distribution Panel
581127000DJ	14	Distribution Panel
581127000DK	14	Distribution Panel
Distribution Panels, Battery Disconnect		
581127000BA	16	Distribution Panel
581127000BB	12	Distribution Panel
581127000BC	10	Distribution Panel
581127000BD	8	Distribution Panel
581127000BE	17	Distribution Panel
581127000BF	20	Distribution Panel
581127000BG	20	Distribution Panel
581127000BH	25	Distribution Panel
Battery Disconnect Contactors		
581127000CA	7	600 Amp Battery Disconnect Contactor
581127000CB	6	1200 Amp Battery Disconnect Contactor
581127000CC	6	2000 Amp Battery Disconnect Contactor
Bulk Output Panel		
581127000EA	11	Bulk Output Panel
Ground Bar		
581127000GA	11	Ground Bar
Low Voltage Disconnect		
581127000LB	1	Low Voltage Battery Disconnect Option
581127000LL	2.5	Low Voltage Load Disconnect Option
Manual Battery Disconnect		
581127000MB	1	Manual Battery Disconnect Option
Distribution Elements		
550224	1.5	Kit, 6-Position GMT Fuse Module, 35 A

Vertiv™ NetSure™ 710NPBA DC Power System
System Application Guide

List Number or Part Number	Net Weight (lbs), each	Description
549017	1.5	Kit, 6-Position GMT Fuse Module, 35 A
256623500	0.6	Circuit Breaker, 250 A, GJ/218, One-pole, Without Shunt
256626200	1.2	Circuit Breaker, 400 A, GJ/218, Two-pole, Without Shunt
256628200	2	Circuit Breaker, 600 A, GJ/218, Three-pole, Without Shunt
550249	3	Circuit Breaker, 800 A, GJ/218, Four-pole, With Shunt
Relay Racks		
543159	32	Relay Rack
543151	35	Relay Rack
543152	36	Relay Rack
543153	42	Relay Rack
543154	44	Relay Rack
543155	46	Relay Rack
543156	51	Relay Rack
543157	63	Relay Rack
543161	103	Relay Rack
543162	113	Relay Rack
541340	243	Relay Rack
547862	246	Relay Rack
543163	81	Relay Rack
543164	123	Relay Rack

RELATED DOCUMENTATION

System Quick Start Guide:	QS581127000
System Installation Instructions:	IM581127000
System User Instructions:	UM581127000
ACU+ Controller User Instructions:	UM1M820BNA
NCU Controller User Instructions:	UM1M830BNA
Rectifier Instructions:	UM1R24-3000
Converter Instructions:	UM1C24481500
Module Mounting Assembly Power Data Sheet:	PD588705200
NCU Controller 2nd Ethernet Port Add-On Kit Instructions:	IM559252
NCU Controller 2nd Ethernet Port Retrofit Kit Instructions:	IM559251
Main Schematic Diagrams:	SD581127000 (System) SD588705201 (Module Mounting Assembly)
Main Wiring Diagrams:	T581127000 (System) T588705201 (Module Mounting Assembly)

BATTERY MANUFACTURER INFORMATION

Some equipment described in this System Application Guide is designed to accommodate batteries from various manufacturers. The following are referenced in this document.

C&D: C&D Technologies, Inc., Powercom Div., 1400 Union Meeting Road, Blue Bell, PA 19422-0858

Deka: East Penn Mfg. Co., Inc., Lyon Station, PA 19536-0147

Douglas: Douglas Battery Mfg. Co., 500 Battery Dr., Winston-Salem, NC 27117-2159

Fiamm: FIAMM T.I., 23880 Industrial Park Drive, Farmington Hills, Detroit, MI 48335

Marathon™: GNB Industrial Power, a Division of Exide Technologies, Princeton, NJ 08543.

Northstar: NorthStar Battery Co. LLC, 4000 Continental Way, Springfield, MO 65803

PowerSafe EnerSys™: EnerSys Inc., Reading, PA, 196212-4145

Vertiv.com | Vertiv Headquarters, 505 N Cleveland Ave, Westerville, OH 43082, USA

© 2026 Vertiv Group Corp. All rights reserved. Vertiv™ and the Vertiv logo are trademarks or registered trademarks of Vertiv Group Corp. All other names and logos referred to are trade names, trademarks or registered trademarks of their respective owners. While every precaution has been taken to ensure accuracy and completeness here, Vertiv Group Corp. assumes no responsibility, and disclaims all liability, for damages resulting from use of this information or for any errors or omissions.

