



CoolPhase Row

Installer/User

600 mm and 300 mm Wide

The information contained in this document is subject to change without notice and may not be suitable for all applications. While every precaution has been taken to ensure the accuracy and completeness of this document, Vertiv assumes no responsibility and disclaims all liability for damages result from use of this information or for any errors or omissions.

Refer to local regulations and building codes relating to the application, installation, and operation of this product. The consulting engineer, installer, and/or end user is responsible for compliance with all applicable laws and regulations relation to the application, installation, and operation of this product.

The products covered by this instruction manual are manufactured and/or sold by Vertiv. This document is the property of Vertiv and contains confidential and proprietary information owned by Vertiv. Any copying, use, or disclosure of it without the written permission of Vertiv is strictly prohibited.

Names of companies and products are trademarks or registered trademarks of the respective companies. Any questions regarding usage of trademark names should be directed to the original manufacturer.

Technical Support Site

If you encounter any installation or operational issues with your product, check the pertinent section of this manual to see if the issue can be resolved by following outlined procedures.

Visit <https://www.vertiv.com/en-us/support/> for additional assistance.

TABLE OF CONTENTS

1 Important Safety Instructions	7
1.1 Pipework	16
1.2 Refrigerant Leak Detection System	16
1.3 Qualification of workers	16
1.3.1 Safety concepts	17
1.3.2 Correct working procedures	17
1.4 Installation, Maintenance, Repair and Decommissioning	19
1.4.1 Checks to the area	19
1.4.2 Work procedure	19
1.4.3 General work area	19
1.4.4 Checking for presence of refrigerant	19
1.4.5 Presence of fire extinguisher	19
1.4.6 No ignition sources	19
1.4.7 Ventilated area	19
1.4.8 Checks to the refrigerant equipment	19
1.4.9 Checks to electrical devices	20
1.4.10 Repair to sealed components and intrinsically safe components	20
1.4.11 Cabling	20
1.4.12 Detection of flammable refrigerants	20
1.4.13 Removal and evacuation	21
1.4.14 Charging procedures	21
1.4.15 Decommissioning	22
1.4.16 Labeling	22
1.4.17 Recovery	22
1.5 Physical Security	24
2 Product Overview	25
2.1 Model Nomenclature	25
2.2 Nameplate Label	26
2.3 Component Location	28
2.4 Accessories	29
2.5 System Data	30
2.6 R-32 Refrigerant	34
3 Pre-Installation Preparation	35
3.1 Tools Required	35
3.2 Dimension and Weights	36
3.3 Clearance Requirements	37
3.4 Inspecting the Unit	38
3.5 Moving the Packaged Unit	38

- 3.6 Unpacking the Unit 39
- 3.7 Removing the Unit from the Pallet 41
- 4 Installing in Enclosure Row 43**
- 4.1 Leveling the Unit 43
- 4.2 Combining the Unit with Adjacent Cabinets 44
- 4.3 Location of the Main Grounding Point (PE) 45
- 4.4 Remove Filters 46
- 4.5 Installing Top Frame and Front Frame (Optional) 47
 - 4.5.1 Installing the Top Frame without the Front Frame 47
 - 4.5.2 Installing the Top Frame and the Front Frame 50
- 5 Piping and Refrigeration Connections 57**
- 5.1 General Arrangement 59
- 5.2 Connecting Drainage Pipes 65
 - 5.2.1 Top Connection 65
 - 5.2.2 Bottom Connection 65
- 5.3 Connecting Water Supply for Humidifier 65
 - 5.3.1 Top Connection 65
 - 5.3.2 Bottom Connection 65
- 5.4 Connecting Gas Pipe and Liquid Pipe 66
- 6 Leak Detection System 69**
- 6.1 Refrigerant Detection System 70
 - 6.1.1 Leak Mitigation Action Steps 70
 - 6.1.2 Safety Shut Off Valve (SSOV) 71
- 7 Electrical Connections 73**
- 7.1 Connecting Power Supply Cables 74
- 7.2 Connecting Communications Cables 78
 - 7.2.1 General Arrangement 78
 - 7.2.2 Connecting Communications Cable between Evaporator and Condenser 79
 - 7.2.3 Connecting the Water Leakage Sensor (Optional) 79
 - 7.2.4 Connecting Alarm Device (Optional) 80
 - 7.2.5 Connecting Remote Temperature Sensors (Optional) 80
 - 7.2.6 Connecting the Remote On/Off Device (Optional) 81
 - 7.2.7 Connecting for Teamwork 81
- 7.3 Electrical Installation Checklist 82
- 8 Start-Up 83**
- 8.1 Charging Refrigerant and Lubricating Oil 83
 - 8.1.1 Amount of Refrigerant and Lubricating Oil 83
- 8.2 Start-Up Procedure 87
 - 8.2.1 First Start-up (or After Long Standstill) 87
- 8.3 Humidifier 89

9 Controls Instructions	91
10 Maintenance	93
10.1 Maintenance Schedule	93
10.2 Air Filters	95
10.3 Fan	95
10.4 Humidifier	97
10.5 Refrigeration Circuit	99
10.6 Dismantling The Unit	101
11 Troubleshooting	103
Appendices	107
Appendix A: Technical Support and Contacts	107
Appendix B: Alarm Table	108
Appendix C: Submittals Drawings	117

This page intentionally left blank

1 Important Safety Instructions

This manual contains important safety instructions that should be followed during the installation and maintenance of the Vertiv™ CoolPhase Row. Read this manual thoroughly before attempting to install or operate this unit.

Only qualified personnel should move, install or service this equipment. This device shall not be installed in areas accessible to public.

Adhere to all warnings, cautions, notices, and installation, operating and safety instructions on the unit and in this manual. Follow all installation, operation and maintenance instructions and all applicable national and local building, electrical and plumbing codes.

Any operation that requires the removal of equipment panels must be carried out only by properly trained and qualified personnel.

To identify the unit model and serial number for assistance or spare parts, locate the nameplate on the unit. Refer to [figure 2.1 Nameplate Location on page 24](#) for more detail.

A warning label on the exterior of the unit, reminds users that:

- All power sources must be disconnected before gain access to internal compartment for any operation.
- The System is design to use R-32 Refrigerant
- Can cause equipment damage, injury, or death. Use only equipment rated for unit weight.

The following safety guidelines are intended to prevent unforeseen risks or damage from unsafe or incorrect operation.

This appliance is not intended for use by persons (including children) with reduced physical, sensory, or mental capabilities, or lack of experience and knowledge, unless they have been given supervision or instruction concerning use of the appliance by a person responsible for their safety.



This appliance is designed to be installed in areas where maximum altitude is 9,843 ft (3,000 m).

For installation only in locations not accessible to the general public.

The appliance shall be installed according to national wiring regulations, follow NFPA 70 National Electrical code and Canadian Electrical Code for the proper electrical installation.

Vertiv™ CoolPhase Row units must be paired only with Vertiv™ CoolPhase Condensing Unit



WARNING! Air outlet of the appliance must be clear of obstruction all time.



WARNING! Room area where the appliance using flammable refrigerant is installed shall be so constructed that any refrigerant leak will not stagnate to create a fire or explosion hazard.



WARNING! Arc flash and electric shock hazard. Disconnect all electric power-supply, verify with a voltmeter that power is Off, and wear approved personal protective equipment, (PPE), before working within the electric control enclosure. Failure to comply can cause serious injury or death. Customer must provide earth ground to unit, per national and local codes, as applicable. Before proceeding with installation, read all instructions, verify that all the parts are included and check the nameplate to be sure the voltage matches available utility power. The Vertiv™ iCOM™ does not isolate power from the unit, even in the “Unit Off” mode. Some internal components require and receive power even during the “Unit Off” mode of the controller. The only way to ensure that there is NO voltage inside the unit, is to disconnect all power-supply sources. Refer to unit electrical schematic. Follow all national and local codes.



WARNING! Risk of electric shock. Power down the unit for 10 minutes before removing any cover.



WARNING! Installation, service and maintenance, and commissioning work must be performed only by properly trained and qualified personnel and in accordance with applicable regulations and manufacturers’ specifications. Opening or removing the covers to any equipment may expose personnel to lethal voltages within the unit even when it is apparently not operating and the input wiring is disconnected from the electrical source.



WARNING! Work shall be undertaken under a controlled procedure so as to minimize the risk of a flammable gas or vapor being present while the work is being performed.



WARNING! All maintenance staff and others working in the local area shall be instructed on the nature of work being carried out. Work in confined spaces shall be avoided.



WARNING! The area shall be checked with an appropriate refrigerant detector prior to and during work, to ensure the technician is aware of potentially toxic or flammable atmospheres. Ensure that the leak detection equipment being used is suitable for use with all applicable refrigerants, i.e. non-sparking, adequately sealed, or intrinsically safe.



WARNING! Risk of over pressurization of the refrigeration system. Can cause explosive discharge of high-pressure refrigerant, loss of refrigerant, environmental pollution, equipment damage, injury, or death. This unit contains fluids and gases under high pressure. Use extreme caution when charging the refrigerant system. Do not pressurize the system higher than the maximum allowable pressure marked on the unit's nameplate.



WARNING! Risk of contact with high-speed rotating fan blades. Can cause serious injury or death. Disconnect all electric power-supply sources, verify with a voltmeter that power is off, and verify that all fan blades have stopped rotating before working in the unit cabinet or on the fan assembly. Fan motor controls and compressor controls can maintain an electric charge for 10 minutes after power is disconnected. If control voltage is applied, the fan motor can restart without warning after a power failure.



WARNING! Risk of hair, clothing and jewelry entanglement with high-speed rotating fan blades. Can cause equipment damage, serious injury or death. Keep hair, jewelry and loose clothing secured and away from rotating fan blades during unit operation.



WARNING! Risk of heavy unit falling over. Improper handling can cause equipment damage, injury or death. Read all the following instructions and verify that all lifting and moving equipment is rated for the weight of the unit before attempting to move, lift, remove packaging from or prepare the unit for installation. Unit weights are specified in subtopic [3.2 Dimensions and Weights](#).



WARNING! Risk of unsecured unit rolling off pallet. Can cause equipment damage, injury or death. The unit is on casters. Ensure that the pallet is located on a flat surface before loosening the hardware securing the to its shipping pallet.



WARNING! Risk of contact with extremely hot and/or cold surfaces. Can cause injury. Verify that all components have reached a temperature that is safe for human contact or wear appropriate PPE before working within the electric connection enclosures or unit cabinet. Perform maintenance only when the system is de-energized and component temperatures have become safe for human contact.



WARNING! Risk of improper wiring, piping, moving, lifting and handling. Can cause equipment damage, serious injury or death. Installation and service of this equipment shall be done only by qualified personnel who have been specially trained in the installation of air conditioning equipment and who are wearing appropriate PPE.



WARNING! Risk of improper wire sizing/rating and loose electrical connections. Can cause overheated wire and electrical connection terminals resulting in smoke, fire, equipment and building damage, injury or death. Use correctly sized copper wire only and verify that all electrical connections are tight before turning power On. Check all electrical connections periodically and tighten as necessary.



WARNING! This Evaporator Unit shall be connected only to a Condenser Unit suitable for R-32 refrigerant.



WARNING! Flammable refrigerant used. To be repaired only by trained service personnel. Do not puncture refrigerant tubing.



WARNING! Flammable refrigerant used. Dispose of properly in accordance with federal or local regulations.



WARNING! Flammable refrigerant used. Read this manual before attempting to service this product. All safety precautions must be followed.



WARNING! Due to flammable refrigerant used. Follow handling instructions carefully in compliance with national regulations.



WARNING! Ventilation openings of the appliance shall remain always clear for any object.



WARNING! No person carrying out work about a refrigerating system which involves exposing any pipe work shall use any sources of ignition in such a manner that it may lead to the risk of fire or explosion. All possible ignition sources, including cigarette smoking, shall be kept sufficiently far away from the site of installation, repairing, removing and disposal, during which refrigerant can possibly be released to the surrounding space. Prior to work taking place, the area around the equipment is to be surveyed to make sure that there are no flammable hazards or ignition risks. “No Smoking” signs shall be displayed.



WARNING! Do not pierce or burn.



WARNING! Be aware that refrigerants may not contain an odour.



CAUTION: Risk of contact with sharp edges, splinters, and exposed fasteners. Can cause injury. Only properly trained and qualified personnel wearing appropriate PPE should attempt to move, lift, unpack or prepare the unit for installation.



CAUTION: If any hot work is to be conducted on the refrigerating equipment or any associated parts, appropriate fire extinguishing equipment shall be available to hand. Have a dry powder or CO2 fire extinguisher adjacent to the charging area.



CAUTION: Risk of improper moving, lifting, and handling. Can cause equipment damage or injury. Only properly trained and qualified personnel should work on this equipment. Use proper lifting techniques and wear appropriate PPE to avoid injury and dropping the evaporator during removal. Equipment used in handling/lifting, and/or installing the evaporator must meet Health and Safety national and local requirements. Use handling/lifting equipment rated for the weight of the evaporator. Use ladders rated for the weight of the evaporator and technicians if used during installation. Refer to handling/lifting, and/or installation equipment operating manual for manufacturer’s safety requirements and operating procedures.



CAUTION: Risk of exposure to harmful noise levels can cause hearing injury or loss. Depending on the installation and operating conditions, a sound pressure level greater than 70 dB(A) may arise. Take appropriate technical safety measures. Operating personnel must wear appropriate PPE and observe all appropriate hearing protection safety requirements.



CAUTION: Risk of excessive refrigerant line pressure. Can cause tubing and component rupture resulting in equipment damage and personal injury. Do not close off the refrigerant line isolation valve for repairs unless a pressure-relief valve is installed in the field between the isolation valve and the check valve. The pressure relief valve must be rated 5% to 10% higher than the system maximum allowable pressure. An increase in ambient temperature can cause the pressure of the isolated refrigerant to rise and exceed the system maximum allowable pressure rating marked on the unit nameplate.



CAUTION: This unit has a Leak Detection System installed. Continuous air circulation required for proper functioning. Unit must be powered except for service.



CAUTION: This unit is equipped with electrically powered safety measures. To be effective, the unit must be electrically powered at all times after installation, other than when servicing.



CAUTION: High touch current, earth connection essential before connecting supply.

NOTICE:

Risk of improper power supply connection. Can cause equipment damage and loss of warranty coverage. Prior to connecting any equipment to a main or alternate power source (for example: backup generator systems) for startup, commissioning, testing, or normal operation, ensure that these sources are correctly adjusted to the nameplate voltage and frequency of all equipment to be connected. In general, power source voltages should be stabilized and regulated to within $\pm 10\%$ of the load nameplate nominal voltage. Also, ensure that no three phase sources are single phased at any time.

NOTICE:

Risk of oil contamination with water. Can cause equipment damage.

Vertiv™ CoolPhase Row systems require the use of PVE (FW68S). Oil absorbs water at a much faster rate when exposed to air than previously used oils. Because water is the enemy of a reliable refrigeration system, extreme care must be used when opening systems during installation or service. If water is absorbed into the oil, it will not be easily removed and will not be removed through the normal evacuation process. If the oil is too wet, it may require an oil change. Oils also have a property that makes them act as a solvent in a refrigeration system. Maintaining system cleanliness is extremely important because the oil will tend to bring any foreign matter back to the compressor.

NOTICE:

Risk of improper refrigerant charging. Can cause equipment damage.

Refrigerant charge must be weighed into air-cooled systems with compressors before they are started. Starting rotative compressors without proper refrigerant charging can cause the compressors to operate at less than 5°F (-15°C) evaporator temperature and at less than 20 psig (138 kPa). Operation for extended periods at less than 20 psig (138 kPa) can cause premature compressor failure.

NOTICE:

Risk of clogged or leaking drain lines and leaking water supply lines. Can cause equipment and building damage.

This unit requires a water drain connection. Drain lines must be inspected at startup and periodically, and maintenance must be performed to ensure that drain water runs freely through the drain system and that lines are clear and free of obstructions and in good condition with no visible sign of damage or leaks.

Improper installation, application and service practices can result in water leakage from the unit. Water leakage can result in catastrophic and expensive building and equipment damage and loss of critical data center equipment.

Do not locate the unit directly above any equipment that could sustain water damage.

We recommend installing a monitored fluid detection system to immediately discover and report condensate drain line leaks.

NOTICE:

Risk of doorway/hallway interference. Can cause unit and/or structure damage. The unit may be too large to fit through a doorway or hallway while on the skid. Measure the unit and passageway dimensions and refer to the installation plans prior to moving the unit to verify clearances.

NOTICE:

Risk of water backing up in the drain line. Leaking and overflowing water can cause equipment and building damage.

NOTICE:

Risk of damage by forklift. May cause damage to the unit. Keep forklift spikes level and at a suitable height to fit under the skid and/or unit to prevent damage to the exterior and/or underside.

NOTICE:

Improper storage may cause damage to the unit. Keep the unit in a vertical position, indoors and protected from humidity, freezing temperatures, and contact damage.

NOTICE:

This unit is not intended to be connected to ducts.

NOTICE:

A service schedule shall be made to verify the safety systems of the appliance are working as intended, at a minimum interval of once per year.

NOTICE:

Risk of release of hazardous substances into the environment. Can cause environmental pollution and violation of environmental regulations.

The Vertiv™ CoolPhase Row contains substances and components hazardous for the environment (electronic components, refrigerating gases and oils). At the end of its useful life, the Vertiv™ CoolPhase Row must be dismantled by specialized refrigerating technicians. The unit must be delivered to suitable centers specializing in the collection and disposal of equipment containing hazardous substances.

NOTE: Use remote corresponding condensing unit.

The unit is marked with various symbols for different purposes, read the part with symbol(s) carefully and follow the instructions to avoid any risk.

Table 1.1 Symbol Description







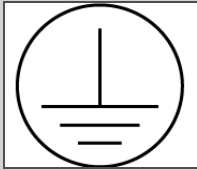

Symbology	Description	
	This symbol is displayed to indicate matters and operations that can cause risk.	
	WARNING This symbol means if the warning is not heeded, it can cause death or serious injury.	
	CAUTION This symbol means if the precaution is not taken, it may cause minor or moderate injury.	
	This symbol is displayed to indicate protective earthing, permanent earthing shall always remain connected other than for small periods of maintenance.	
	These symbols are displayed to indicate matters related to the operation of the appliance.	
		
	This symbol is displayed to indicate matters related to the servicing of the appliance. The information contained in the manual is intended for use by a qualified service technician who is familiar with the safety procedures and equipped with the proper tools and test instruments.	

Table 1.1 Symbol Description (continued)

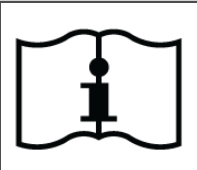
Symbology	Description
	<p>These symbols are displayed to indicate matters related to flammable refrigerant.</p>
	
	<p>This symbol is displayed to indicate moving fan blades during normal operation.</p>
	<p>This symbol is displayed to indicate hazardous voltage involved or risk of electric shock. This symbol might be followed by 'CAUTION' or 'WARNING' wording to indicate the level of risk.</p>
	<p>This symbol is displayed to indicate of potential hot surfaces.</p>

NOTICE:

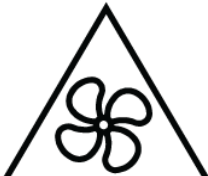
Due to the use of flammable refrigerant, systems using R-32 with a charge exceeding 1.836 kg (4.05 lbs) must be installed in unventilated rooms with a minimum room volume.

Unventilated room areas shall be constructed so that in case of any refrigerant leak, it will not stagnate nor create a fire or explosion hazard.

NOTICE:

Appliances using R-32 with a refrigerant charge exceeding 3.9 lbs (1.8 kg) must not be installed in unventilated areas, additional natural or mechanical ventilation is required within the room.

Ventilation shall be made following the requirements for machinery rooms in the applicable sections of ISO 5149:-3-2014, ANSI/ASHRAE 15 (USA) and/or CSA B52 (Canada).

NOTICE:

Handling, installation, cleaning, servicing, and disposal of refrigerant must be made only by qualified personnel.

1.1 Pipework

Pipe-work shall be kept to a minimum length.

Pipe-work shall be protected from physical damage and shall not be installed in an unventilated space.

Compliance with national gas regulations shall be observed.

Mechanical connections shall be accessible for maintenance purposes.

Pipe-work including piping material, pipe routing, and installation shall include protection from physical damage in operation and service and be in compliance with national and local codes and standards, such as ASHRAE 15, ASHRAE 15.2, IAPMO Uniform Mechanical Code, ICC International Mechanical Code, or CSA B52. All field joints shall be accessible for inspection prior to being covered or enclosed.

After completion of field piping for split systems, the field pipework shall be pressure tested with an inert gas and then vacuum tested prior to refrigerant charging.

For a proper vacuum in the units, ensure to connect hoses in the suction and liquid service valves located in the CoolPhase Condensing Unit units.

Additionally, connect a hose in the Schrader valve located in the compressor discharge line.

Field-made refrigerant joints indoors shall be tightness tested. The test method shall have a sensitivity of 5 grams per year of refrigerant or better under a pressure of at least 0.25 times the maximum allowable pressure. No leak shall be detected.

1.2 Refrigerant Leak Detection System

Leak sensor readings will control the activation of the leak detection routine, as well as it will command the closing of the valve.

Leak Mitigation Action Steps:

- Detect leak.
- Shut down the compressor.
- Close the EEV valve.
- Safety Shut Off Valve (SSOV) closes.
- CoolPhase Row fans at full speed.
- Alarms on the Human Machine Interface (HMI) to be displayed:
 - Coolant leaks exist.
 - Coolant emergency routine
 - Safety Shut Off Valve (SSOV) closed.

These actions will remain until the unit is de-genericized for troubleshooting.

1.3 Qualification of workers

Every working procedure that affects safety means shall only be carried out by competent personnel.

Information of procedures additional to usual information for refrigerating appliance installation, repair, maintenance and decommission procedures is required when an appliance with flammable refrigerants is affected.

The training of these procedures is carried out by national training organizations or manufacturers that are accredited to teach the relevant national competency standards that may be set in legislation. The achieved competence should be documented by a certificate.

1.3.1 Safety concepts

Unventilated:

Safety of the appliance does not depend on ventilation of the housing. Switching off the appliance or opening of the housing has no significant effect on safety. Nevertheless, it is possible that leaking refrigerant may accumulate inside the enclosure and flammable atmosphere will be released when the enclosure is opened.

Ventilated enclosure:

Safety of the appliance depends on ventilation of the housing. Switching off the appliance or opening of the enclosure has a significant effect on safety. Care should be taken to ensure sufficient ventilation before.

Ventilated room:

Safety of the appliance depends on the ventilation of the room. Switching off the appliance or opening of the housing has no significant effect on safety. The ventilation of the room shall not be switched off during repair procedures.

1.3.2 Correct working procedures

Commissioning

- Ensure that the floor area is sufficient for the refrigerant charge or that the ventilation duct is assembled in a correct manner.
- Connect the pipes and carry out a leak test before charging with refrigerant.
- Check safety equipment before putting it into service.

Maintenance

- Ensure sufficient ventilation at the repair place.
- Be aware that malfunction of the equipment may be caused by refrigerant loss and a refrigerant leak is possible.
- Discharge capacitors in a way that won't cause any spark. The standard procedure to short circuit the capacitor terminals usually create sparks.
- Reassemble sealed enclosures accurately. If seals are worn, replace them.
- Check safety equipment before putting into service

Repair

- Ensure sufficient ventilation at the repair place.
- Be aware that malfunction of the equipment may be caused by refrigerant loss and a refrigerant leak is possible.
- Discharge capacitors in a way that won't cause any spark.
- When brazing is required, the following procedures shall be carried out in the right order:

- Safely remove the refrigerant following local and national regulations. Take care that the reclaimed refrigerant will not cause any danger. In doubt, one person should guard the outlet. Take special care that reclaimed refrigerant will not float back into the building.
- Purge the refrigerant circuit with oxygen free nitrogen.
- Evacuate the refrigerant circuit.
- Purge the refrigerant circuit with nitrogen for 5 minutes (optional for A2L refrigerants).
- Evacuate again (optional for A2L refrigerants).
- Remove parts to be replaced by cutting, not by flame.
- Purge the braze point with nitrogen during the brazing procedure.
- Carry out a leak test before charging with refrigerant.

Reassemble sealed enclosures accurately. If seals are worn, replace them. Check safety equipment before putting it into service.

Decommissioning

- If safety is affected when the equipment is put out of service, the refrigerant charge shall be removed before decommissioning.
- Ensure sufficient ventilation at the equipment location.
- Be aware that malfunction of the equipment may be caused by refrigerant loss and a refrigerant leak is possible.
- Discharge capacitors in a way that won't cause any spark.
- Remove the refrigerant. Take care that the reclaimed refrigerant will not cause any danger. In doubt, one person should guard the outlet. Take special care that reclaimed refrigerant will not float back into the building.
- When flammable refrigerants except A2L refrigerants are used:
 - Evacuate the refrigerant circuit.
 - Purge the refrigerant circuit with nitrogen for 5 minutes.
 - Evacuate again.
 - Fill with nitrogen up to atmospheric pressure.
 - Put a label on the equipment so that the refrigerant is removed.

Disposal

Ensure sufficient ventilation at the working place.

Remove the refrigerant. Take care that the reclaimed refrigerant will not cause any danger. In doubt, one person should guard the outlet. Take special care that reclaimed refrigerant will not float back into the building.

When flammable refrigerants are used:

- Evacuate the refrigerant circuit.
- Purge the refrigerant circuit with oxygen free nitrogen for 5 minutes.
- Evacuate again, (optional for A2L refrigerants).
- Cut out the compressor and drain the oil.

1.4 Installation, Maintenance, Repair and Decommissioning

1.4.1 Checks to the area

Prior to beginning work on systems containing flammable refrigerants, safety checks are necessary to ensure that the risk of ignition is minimized. For repair to the refrigerating system, servicing procedure shall be completed prior to conducting work on the system.

1.4.2 Work procedure

Work shall be undertaken under a controlled procedure so as to minimize the risk of a flammable gas or vapor being present while the work is being performed.

1.4.3 General work area

All maintenance staff and others working in the local area shall be instructed on the nature of the work being carried out. Work in confined spaces shall be avoided.

1.4.4 Checking for presence of refrigerant

The area shall be checked with an appropriate refrigerant detector prior to and during work, to ensure the technician is aware of potentially toxic or flammable atmospheres. Ensure that the leak detection equipment being used is suitable for use with all applicable refrigerants, i.e. non-sparking, adequately sealed or intrinsically safe.

1.4.5 Presence of fire extinguisher

If any hot work is to be conducted on the refrigerating equipment or any associated parts, appropriate fire extinguishing equipment shall be available to hand. Have a dry powder or CO₂ fire extinguisher adjacent to the charging area.

1.4.6 No ignition sources

No person carrying out work in relation to a refrigerant system which involves exposing any pipe work shall use any sources of ignition in such a manner that it may lead to the risk of fire or explosion. All possible ignition sources, including cigarette smoking, should be kept sufficiently far away from the site of installation, repairing, removing and disposal, during which refrigerant can possibly be released to the surrounding space. Prior to work taking place, the area around the equipment is to be surveyed to make sure that there are no flammable hazards or ignition risks. **“No Smoking”** signs shall be displayed.

1.4.7 Ventilated area

Ensure that the area is open or that it is adequately ventilated before performing work on the system or conducting any hot work. A degree of ventilation shall continue during the period that the work is carried out. The ventilation should safely disperse any released refrigerant and preferably expel it externally into the atmosphere.

1.4.8 Checks to the refrigerant equipment

Where electrical components are being replaced, they shall be fit for the purpose and to the correct specification. At all times the Vertiv™ maintenance and service guidelines shall be followed. If in doubt, consult the technical department for assistance.

The following checks shall be applied to installations using flammable refrigerants:

- The actual refrigerant charge is in accordance with the room size within which the refrigerant containing parts are installed.
- The ventilation machinery and outlets are operating adequately and are not obstructed.
- If an indirect refrigerating circuit is being used, the secondary circuit shall be checked for the presence of refrigerant.
- Marking to the equipment continue to be visible and legible. Markings and signs that are illegible shall be corrected.
- Refrigeration piping or components are installed in a position where they are unlikely to be exposed to any substance which may corrode refrigerant containing components, unless the components are constructed of materials which are inherently resistant to being corroded or are suitably protected against being so corroded.

1.4.9 Checks to electrical devices

Repair and maintenance of electrical components shall include initial safety checks and component inspection procedures. If a fault exists that could compromise safety, then no electrical supply shall be connected to the circuit until it is satisfactorily dealt with. If the fault cannot be corrected immediately but it is necessary to continue operation, an adequate temporary solution shall be used. This shall be reported to the owner of the equipment, so all parties are advised.

Initial safety checks shall include:

- That capacitors are discharged: this shall be done in a safe manner to avoid the possibility of sparking.
- That no live electrical components and wiring are exposed while charging, recovering or purging the system.
- That there is continuity of earth bonding.

1.4.10 Repair to sealed components and intrinsically safe components

- Sealed electrical components shall be replaced.
- Intrinsically safe components must be replaced.

1.4.11 Cabling

Check that cabling will not be subject to wear, corrosion, excessive pressure, vibration, sharp edges or any other adverse environmental effects. The check shall also take into account the effects of aging or continual vibration from sources such as compressors or fans.

1.4.12 Detection of flammable refrigerants

Under no circumstances shall potential sources of ignition be used in the searching for or detection of refrigerant leaks. A halide torch (or any other detector using a naked flame) shall not be used.

Electronic leak detectors may be used to detect refrigerant leaks, but the sensitivity may not be adequate for flammable refrigerants and may require recalibration. Detection equipment shall be calibrated in a refrigerant-free area. Ensure that the detector is not a potential source of ignition and is suitable for the refrigerant used. Leak detection equipment shall be set at a percentage of the LFL (Lower Flammable Limit) of the refrigerant and shall be calibrated to the refrigerant employed, and the appropriate percentage of gas (25 % maximum) is confirmed.

Leak detection fluids are also suitable for use with most refrigerants but the use of detergents containing chlorine shall be avoided as the chlorine may react with the refrigerant and corrode the copper pipework. Examples of leak detection fluids are bubble method and fluorescent method agents.

If a leak is suspected, all naked flames shall be removed/extinguished.

If a leakage of refrigerant is found which requires brazing, all the refrigerant shall be recovered from the system, or isolated (by means of shut off valves) in a part of the system remote from the leak. Removal of refrigerant shall be according to Removal and evacuation procedures.

1.4.13 Removal and evacuation

When breaking into the refrigerant circuit to make repairs – or for any other purpose – conventional procedures shall be used. However, for flammable refrigerants it is important that best practice be followed, since flammability is a consideration. The following procedure shall be adhered to:

- Safely remove refrigerant following local and national regulations.
- Evacuate.
- Purge the circuit with inert gas (optional for A2L).
- Evacuate (optional for A2L).
- Continuously flush or purge with inert gas when using flame to open circuit.
- Open the circuit.

The refrigerant charge shall be recovered into the correct recovery cylinders. For appliances containing flammable refrigerants, the system shall be purged with oxygen-free nitrogen to render the appliance safe for flammable refrigerants. This process might need to be repeated several times. Compressed air or oxygen shall not be used for purging refrigerant systems.

For appliances containing flammable refrigerants, refrigerants purging shall be achieved by breaking the vacuum in the system with oxygen-free nitrogen and continuing to fill until the maximum allowable pressure is achieved, then venting to atmosphere, and finally pulling down to a vacuum. This process shall be repeated until no refrigerant is within the system. When the final oxygen-free nitrogen charge is used, the system shall be vented down to atmospheric pressure to enable work to take place. This operation is vital if brazing operations on the pipework are to take place.

The outlet for the vacuum pump is not close to any potential ignition sources and ventilation shall be available.

1.4.14 Charging procedures

In addition to conventional charging procedures, the following requirements shall be followed:

- Ensure that contamination of different refrigerants does not occur when using charging equipment. Hoses or lines shall be as short as possible to minimize the amount of refrigerant contained in them.
- Cylinders shall be kept in an appropriate position according to the instructions.
- Ensure that the refrigerating system is earthed prior to charging the system with refrigerant.
- Label the system when charging is complete (if not already).
- Extreme care shall be taken not to overfill the refrigerating system.

Prior to recharging the system, it shall be pressure-tested with the appropriate purging gas. The system shall be leak-tested on completion of charging but prior to commissioning. A follow up leak test shall be carried out prior to leaving the site.

1.4.15 Decommissioning

Before carrying out this procedure, it is essential that the technician is completely familiar with the equipment and all its details. It is recommended good practice that all refrigerants are recovered safely. Prior to the task being carried out, an oil and refrigerant sample shall be taken in case analysis is required prior to re-use of recovered refrigerant. It is essential that electrical power is available before the task is commenced.

- a. Become familiar with the equipment and its operation.
- b. Isolate system electrically.
- c. Before attempting the procedure, ensure that:
 - Mechanical handling equipment is available, if required, for handling refrigerant cylinders.
 - All personal protective equipment is available and being used correctly.
 - The recovery process is always supervised by a competent person.
 - Recovery equipment and cylinders conform to the appropriate standards.
- d. Pump down refrigerant system, if possible.
- e. If a vacuum is not possible, make a manifold so that refrigerant can be removed from various parts of the system.
- f. Make sure that cylinder is situated on the scales before recovery takes place.
- g. Start the recovery machine and operate in accordance with instructions.
- h. Do not overfill cylinders (no more than 80 % volume liquid charge).
- i. Do not exceed the maximum working pressure of the cylinder, even temporarily.
- j. When the cylinders have been filled correctly and the process completed, make sure that the cylinders and the equipment are removed from site promptly and all isolation valves on the equipment are closed off.
- k. Recovered refrigerant shall not be charged into another refrigerating system unless it has been cleaned and checked.

1.4.16 Labeling

Equipment shall be labelled stating that it has been de-commissioned and emptied of refrigerant. The label shall be dated and signed. For appliances containing flammable refrigerants, ensure that there are labels on the equipment stating the equipment contains flammable refrigerant.

1.4.17 Recovery

When removing refrigerant from a system, either for servicing or decommissioning, it is recommended good practice that all refrigerants are removed safely.

When transferring refrigerant into cylinders, ensure that only appropriate refrigerant recovery cylinders are employed. Ensure that the correct number of cylinders for holding the total system charge is available. All cylinders to be used are designated for the recovered refrigerant and labelled for that refrigerant (i.e. Special cylinders for the recovery of refrigerant). Cylinders shall be complete with pressure-relief valve and associated shut-off valves in good working order. Empty recovery cylinders are evacuated and, if possible, cooled before recovery occurs.

The recovery equipment shall be in good working order with a set of instructions concerning the equipment that is at hand and shall be suitable for the recovery of all appropriate refrigerants including, when applicable, flammable refrigerants. In addition, a set of calibrated weighing scales shall be available and in good working order. Hoses shall be complete with leak-free disconnect couplings and in good condition. Before using the recovery machine, check that it is in satisfactory working order, has been properly maintained and that any associated electrical components are sealed to prevent ignition in the event of a refrigerant release. Consult manufacturer if in doubt.

The recovered refrigerant shall be processed according to local legislation in the correct recovery cylinder, and the relevant waste transfer note arranged. Do not mix refrigerants in recovery units and especially not in cylinders.

If compressors or compressor oils are to be removed, ensure that they have been evacuated to an acceptable level to make certain that flammable refrigerant does not remain within the lubricant. The compressor body shall not be heated by an open flame or other ignition sources to accelerate this process. When oil is drained from a system, it shall be carried out safely.

1.5 Physical Security

This product is designed and intended to be deployed and operated in a physically secure and network firewall-protected location. Vertiv recommends a review of the physical security and operating environment of the unit. Since an attacker or disgruntled user can cause serious disruption, below are some recommended best practices that include, but are not limited to:

- Restrict access to areas, racks, and units with encrypted card RFID/badges, unique multi-factor passcode authentication for access, man traps, and biometric scanners for physical access to the equipment.
- Have trusted and background-checked security guards with 24 x 7 x 365 physical presence and written logs to help document and note physical access to a data center, building, rack, and so on.
- Restrict physical access to telecommunications equipment and network cabling. Physical access to the telecommunications lines and network cabling should be restricted to protect against attempts to intercept or sabotage communications. Best practices include use of metal conduits for the network cabling running between equipment cabinets.
- All USB, RJ45, and/or any other physical ports should be restricted on the units.
- Do not connect removable media (such as USB devices, SD cards, and so on) for any operation (such as firmware upgrade, configuration change, or boot application change) unless the origin of media is known and trusted. Before connecting any portable device through a USB port or SD card slot, scan the device for malware and viruses.

2 Product Overview

The Vertiv™ CoolPhase Row cooling units are specifically created and designed for small to medium data centers, computer rooms, equipment rooms, and similar high heat density environments.

The Vertiv™ CoolPhase Row indoor units are used together with the Vertiv™CoolPhase Condensing Unit . CoolPhase Row provide power to the CoolPhase Condensing Unit and control their operation.

2.1 Model Nomenclature

Table 2.1 below and Table 2.2 below describe the model number for the Vertiv™ CoolPhase Row units.

Table 2.1 Model Number Descriptions for the Vertiv™ Evaporator Unit.

SKU	Description
CRD0300-000A0000	CoolPhase Row CRD030 208-230/1/50-60 UL Cooling Only
CRD0301-P00A0000	CoolPhase Row CRD030 208-230/3/60 UL with humidifier and reheat
CRD0304-P00A0000	CoolPhase Row CRD030 460/3/60 UL with humidifier and reheat
CRD0400-000A0000	CoolPhase Row CRD040 208-230/1/50-60 UL Cooling Only
CRD0401-P00A0000	CoolPhase Row CRD040 208-230/3/60 UL with humidifier and reheat
CRD0404-P00A0000	CoolPhase Row CRD040 460/3/60 UL with humidifier and reheat

Table 2.2 CoolPhase Row Model Number Example

Model Number															
1	2	3	4	5	6	7	8	9	10	11	12	13	14	15	16
C	R	D	0	3	0	0	-	0	0	0	A	0	0	0	0

Table 2.3 CoolPhase Row CRD030 and CRD040 Model number Digit and Description Nomenclature

Digits, variables and descriptions
Digits 1-2 - Unit Family <ul style="list-style-type: none"> CR= Vertiv™CoolPhase Row
Digit 3 - System Type <ul style="list-style-type: none"> D= Air Cooled
Digit 4-6 - Model Number <ul style="list-style-type: none"> 0, 030, 040
Digit 7 - Power Supply <ul style="list-style-type: none"> 0= 208/230 V, 1-phase, 50/60 Hz, UL 1= 208/230 V, 3-phase, 60 Hz, UL 4= 460 V, 3-phase, 60 Hz UL
Digit 8 - Separator
Digit 9 - Cooling System

Table 2.3 CoolPhase Row CRD030 and CRD040 Model number Digit and Description Nomenclature (continued)

Digits, variables and descriptions
<ul style="list-style-type: none">• 0= Cooling Only• P= Reheat and humidifier
Digit 10 - Free Digit
Digit 11 - Free Digit
Digit 12 - Revision <ul style="list-style-type: none">• A-Z
Digits 13 - 16 - Factory Configuration Number <ul style="list-style-type: none">• 0000 = Standard• 4 digits other than 0= Engineering To Order designated number

2.2 Nameplate Label

Figure 2.1 Nameplate Label Location on CoolPhase Row CRD030 Units

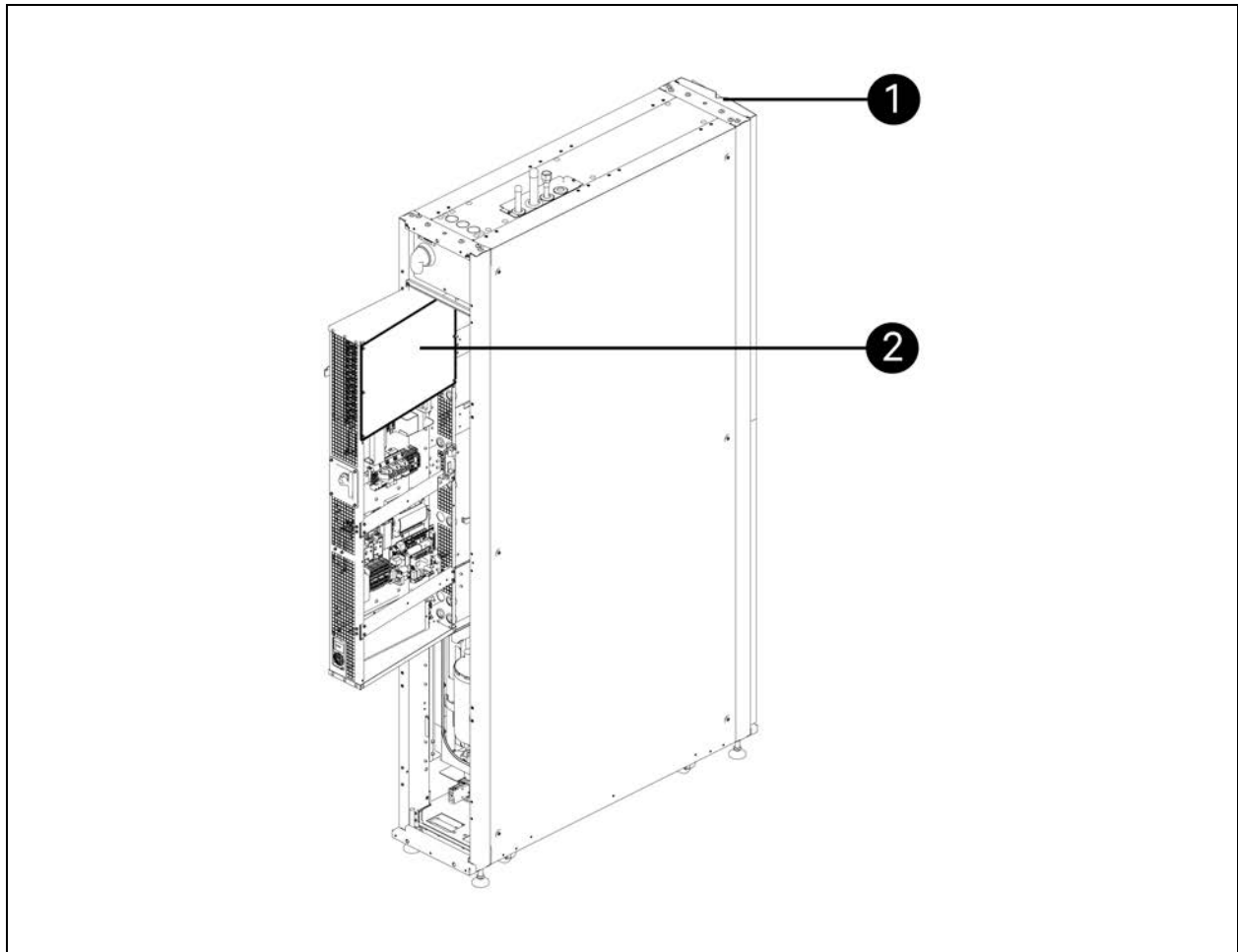

2.3 Component Location

Figure 2.3 Vertiv™ CoolPhase Row CRD030 Component Location

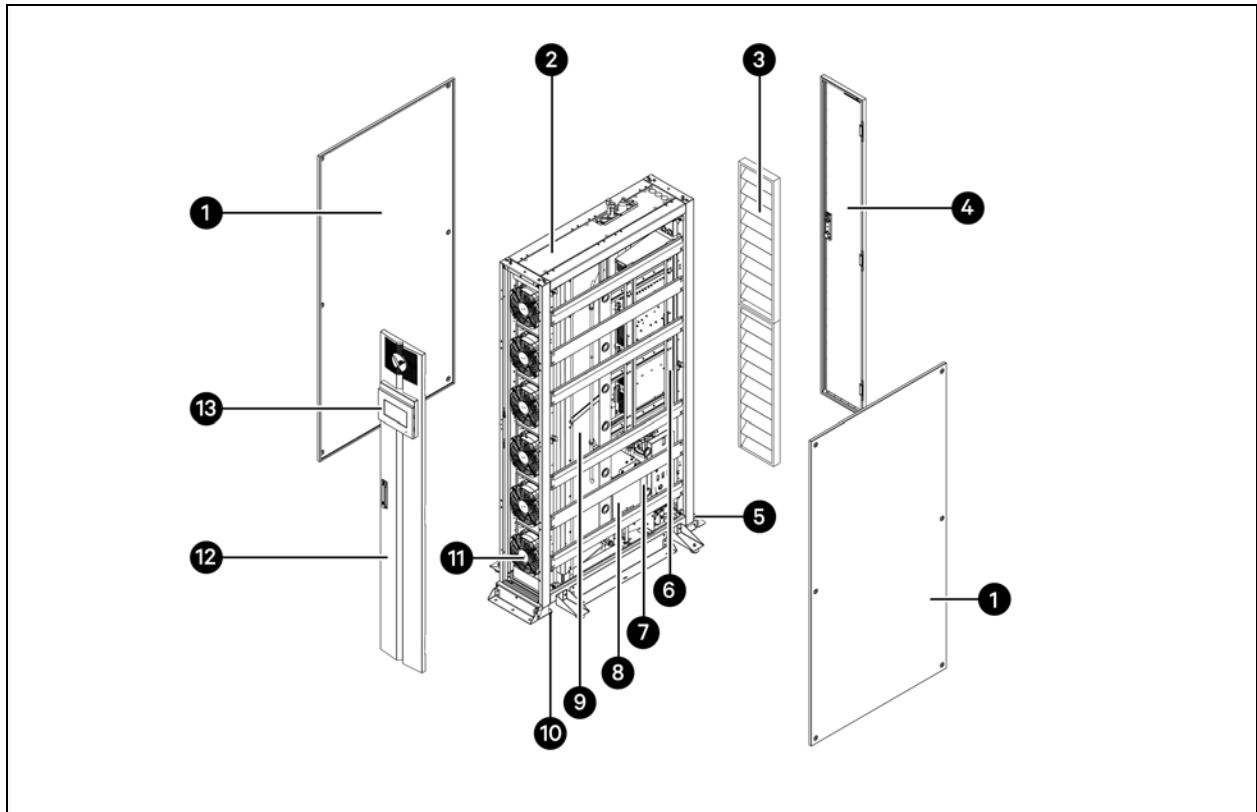

Item	Description	Quantity	Item	Description	Quantity
1	Side Panel	2	8	Transformer	1
2	Top Panel	1	9	Heat Exchanger	1
3	Filter	2	10	Leveling Feet	4
4	Rear Door	1	11	EC Fans	6
5	Bottom Panel	1	12	Front Door	1
6	Slider electrical box (electrical box 2)	1	13	Human Machine Interface (HMI)	1
7	Humidifier	1	-	-	-

Figure 2.4 Vertiv™ CoolPhase Row CRD040 Component Location

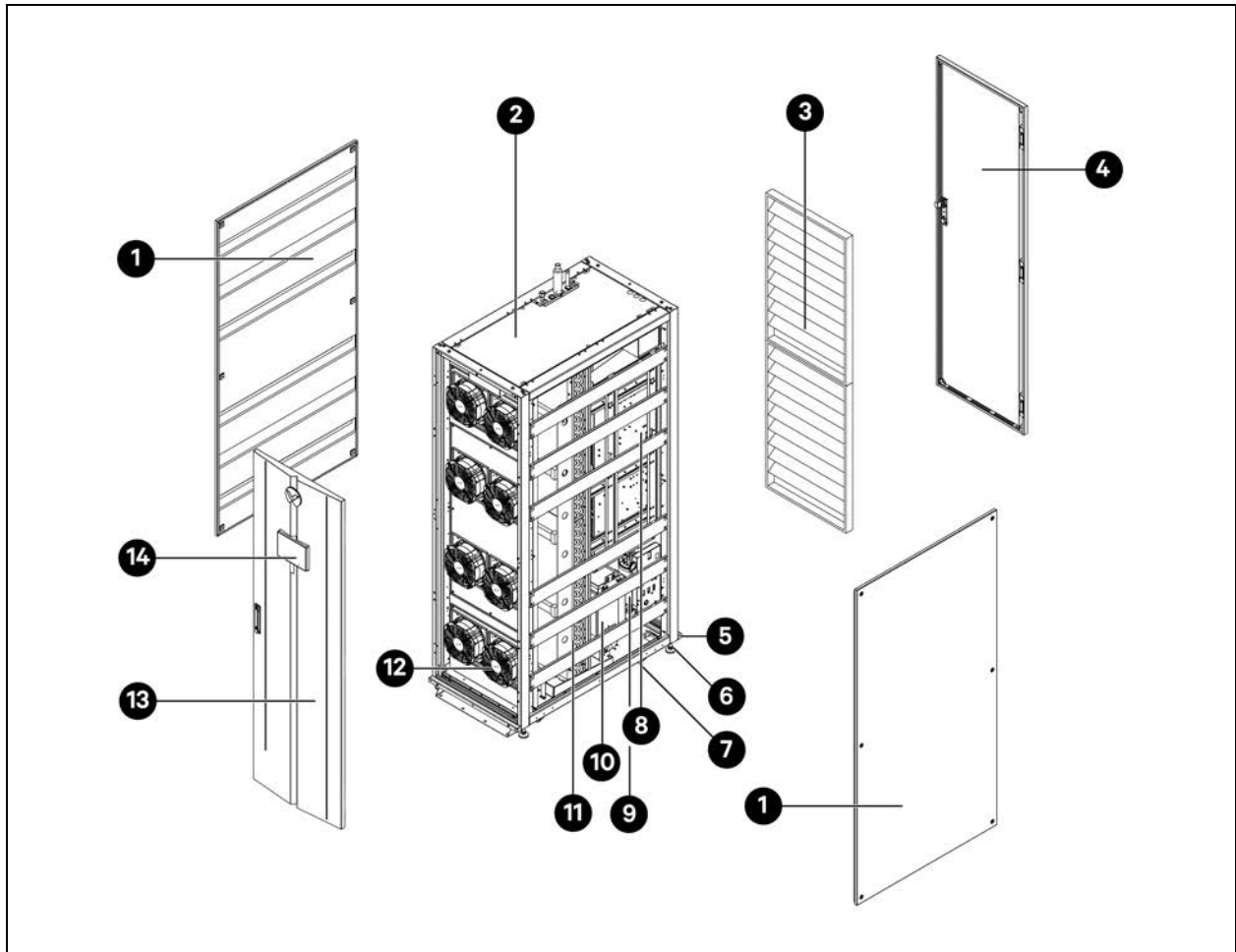

Item	Description	Quantity	Item	Description	Quantity
1	Side Panel	2	8	Slider electrical box (electrical box 2)	1
2	Top Panel	1	9	Humidifier	1
3	Filter	2	10	Transformer	1
4	Rear Door	1	11	Heat Exchanger	1
5	Bottom Panel	1	12	EC Fans	8
6	Leveling Feet	4	13	Front Door	1
7	Casters	4	14	Human Machine Interface (HMI)	1

2.4 Accessories

The accessories provided with the unit are listed in the table below.

Table 2.4 Accessories for Vertiv™ CoolPhase Row Units

Accessories
Power Meter 208/230V, 1Ph
Power Meter 208/230V, 3Ph
Power Meter 460V
User Manual
Safety Statement
Unpacking Instructions
Handling Instructions

2.5 System Data

Table 2.5 Technical Specifications

Parameter	CRD0300-000A	CRD0400-000A	CRD301-P00A	CRD401-P00A	CRD304-P00A	CRD404-P00A
Certification Marks	cCSAus (UL 60335-2-40 and CSA 60335-2-40)					
Width mm in. (mm)	11.8 (300)	23.6 (600)	11.8 (300)	23.6 (600)	11.8 (300)	23.6 (600)
Input power	AC 208-230 V /1PH/ 50-60Hz		AC 208-230 V /3PH/ 60Hz		AC 460 V /3PH/ 50-60Hz	
Total airflow rated CFM (m3/h)	3,900 (6,626)	5,700 (9,684)	3,900 (6,626)	5,700 (9,684)	3,900 (6,626)	5,700 (9,684)
Total fan power consumption maximum kW (Amp)	2.5 (11.99)	3.5 (17)	2.5 (11.99)	3.5 (17)	2.5 (6)	3.5 (8.5)
Evaporator Fans	EC Motor					
Number of fans	6	8	6	8	6	8
Cooling capacity (kW)	30	40	30	40	30	40
Heating capacity (kW)	3					
Minimum cooling capacity (kW)	15	15	15	17	17	17
Humidification capacity lb/h (kg/h)	6.61 (3)					
Condensate pump capacity GPM(L/min at 5 m)	2.64 (10)					
	Maximum head:19.68ft (6m)					
Controls	Vertiv™ iCOM™					
Refrigerant	R-32					
Piping Connections	Sweat connection + Flare Connections					
Equivalent Piping Length ft (m)	295.2 (90)					
Air filtration efficiency	G4					

Table 2.6 Storage Environment

Item	Requirements
Storage environment	Store the unit in its original factory packaging, in a clean indoor environment with good ventilation and with no dust.
Ambient temperature	-40°F ~ to 158°F (-40°C~ to 70°C)
Ambient humidity	Less than 95% RH @ 86°F (30°C)

Table 2.7 Operating Limits

Parameter		Design Condition (Min.)	Design Condition (Max.)
Unit entering air	Temperature °F (°C)	64.4 (18)	113 (45)
	Relative Humidity	17%	60%
Outdoor air	Temperature °F (°C)	-4 (-20)	118.4 (48) Note: Unit remains operational up to 125.6 °F (52 °C) with reduced capacity
		With low ambient version	-31 (-35)
Power supply tolerances		Voltage ± 10%	
		Frequency ± 3 Hz	
Height between evaporator and condenser ft (m)	Condenser placed higher than evaporator	98.4 (30)	
	Condenser placed lower than evaporator	26.2 (8)	

NOTE: The operating limits refer to new units and those that have been correctly installed and serviced.

NOTE: If the altitude is higher than 6562 ft (2000 m) , contact Vertiv™ Support.

NOTE: For information about the height between evaporator and condenser with low ambient version, see [Figure 5.2](#) .

Table 2.8 Performance Data

Parameter	CRD030	CRD040
Return air condition: 95°F (35 °C) DB, 24% RH; outdoor condition: 95°F (35 °C)		
Net total capacity kW (kBtu/h)	30 (104.2)	40.1 (137)
Net sensible capacity kW (kBtu/h)	28.3 (96.6)	40 (136.4)
Indoor unit power input kW (kBtu/h)	1.34 (4.63)	1.90 (6.49)
System power input (indoor unit + outdoor unit) kW (kBtu/h)	9.31 (31.74)	10.40 (35.4)

Table 2.9 Sound Level (50 Hz to 250 Hz)

Model	Fan Speed	Average Sound Pressure Level dB (A)	Location	1/3 Octave Band Center Freq	50 Hz	63 Hz	80 Hz	100 Hz	125 Hz	160 Hz	200 Hz	250 Hz
				Sound Pressure Level dB (A)	dB							
CRD030	100%	90.54	Front	90.62	42.36	46.67	50.29	54.38	57.76	59.91	63.21	66.95
			Left	85.67	30.71	36.37	40.10	46.51	53.01	55.91	56.68	61.39
			Right	87.62	32.20	36.69	40.39	47.24	54.53	56.66	58.98	62.08
CRD040	100%	81.34	Front	81.30	41.33	44.62	50.49	50.15	51.76	53.96	55.53	57.51
			Left	84.69	27.07	33.36	39.91	51.65	50.22	51	65.31	63.68
			Right	84.77	29.77	35.83	40.66	52.15	50.99	51.78	71.99	69.56

Table 2.10 Sound Level (315 Hz to 1.6 kHz)

Model	Fan Speed	Average Sound Pressure Level dB (A)	Location	1/3 Octave Band Center Freq	315 Hz	400 Hz	500 Hz	630 Hz	800 Hz	1 kHz	1.25 kHz	1.6 kHz
				Sound Pressure Level dB (A)	dB							
CRD030	100%	90.54	Front	90.62	68	70.78	76.88	82.65	73.94	75.85	80.65	79.78
			Left	85.67	62.97	66.66	73.67	80.79	69.88	69.65	74.41	74.07
			Right	87.62	63.84	67.23	75.11	83.40	71.10	71.35	76.16	75.82
CRD040	100%	81.34	Front	81.30	61.56	74.85	64.45	63.17	67.41	66.95	70	71.21
			Left	84.69	61.30	63.66	79.33	72.21	66.99	73.32	71.88	73.91
			Right	84.77	61.78	64.80	79.81	71.60	66.85	72.94	71.30	73.18

Table 2.11 Sound Level (2 kHz to 10 kHz)

Model	Fan Speed	Average Sound Pressure Level dB (A)	Location	1/3 Octave Band Center Freq	2 kHz	2.5 kHz	3.15 kHz	4 kHz	5 kHz	6.3 kHz	8 kHz	10 kHz
				Sound Pressure Level dB (A)	dB							
CRD030	100%	90.54	Front	90.62	80.14	81.51	80.16	78.77	76.79	75.18	71.92	67.68
			Left	85.67	74.20	75.26	73.92	72.26	70.17	67.30	63.09	58.16
			Right	87.62	75.76	76.63	74.99	72.88	70.69	68.11	64.45	59.97
CRD040	100%	81.34	Front	81.30	76.37	76.63	74.82	73.15	72.40	70.97	67.77	64.80
			Left	84.69	74.53	74.36	72.86	71.17	69.29	66.83	64.25	60.60
			Right	84.77	74.11	74.33	72.67	71.24	69.03	66.60	63.49	59.53

NOTE: Measurement Standard: EN 13487

NOTE: The sound level is measured in free field at three locations, each of which is 1 m (3.3 ft) high and 2 m (6.6 ft) away from the air conditioner, with fans in operation.

2.6 R-32 Refrigerant

R-32 is a refrigerant of next generation that carries heat efficiently. Also known as difluoromethane and belongs to the HFC family of refrigerant, has a lower GWP (675) and lower impact on the environment in comparison with R-410A and R22. This refrigerant is easier to recycle and use much less amount versus R-410A, therefore, is more efficient with less operating and maintenance costs.

List of characteristics and benefits versus R-410A:

- Zero ODP (Ozone Depletion Potential)
- Can be charged from either the liquid or vapor phase.
- A Gas refrigerant cylinders have dual port valves, making liquid offtake easier.
- Mildly flammable, non-toxic with a safety classification of A2L
- One third of R-410A GWP.
- Required less charge as it has a 20% higher volumetric capacity.
- Similar saturated pressure hence development is easier.
- Higher critical temperature, consequently higher COP.
- Lower density, therefore, the amount of charge required is smaller.
- Single component of gas, therefore it is easier to be produced and managed.



WARNING! Risk of piping ruptures and refrigerant leaks. Can cause equipment damage, illness, severe injury and death from suffocation. Do not use piping that is not approved for use in high-pressure refrigerant systems. Refrigerant leaks in non-ventilated spaces could cause oxygen depletion levels that are dangerous to discharging and charging.

3 Pre-Installation Preparation



WARNING! Risk of top-heavy unit falling over when improperly lifted or moved. Improper handling can cause equipment damage, injury or death. Read all of the following instructions and verify that all lifting and moving equipment is rated for the weight of the unit before attempting to move, lift, unpack or prepare the unit for installation.



CAUTION: Risk of contact with sharp edges, splinters, and exposed fasteners. Can cause injury. Only properly trained and qualified personnel wearing appropriate, OSHA-approved PPE should attempt to move, lift, remove packaging from or prepare the unit for installation.

NOTICE

Risk of passageway interference. Can cause unit and/or structure damage. The unit may be too large to fit through a passageway while on or off the skid. Measure the unit and passageway dimensions and refer to the installation plans prior to moving the unit to verify clearances.

NOTICE

Risk of damage from forklift. Can cause unit damage. Keep tines of the forklift level and at a height suitable to fit below the skid and/or unit to prevent exterior and/or underside damage.

NOTICE

Risk of improper storage. Can cause unit damage. Keep the unit in its original package, upright, indoors and protected from dampness, freezing temperatures and contact damage.

3.1 Tools Required

The tools required are listed in Table 3.1 . These tools are not provided with the unit.

Table 3.1 Tools Required

Name of Tools	
Electric hand drill	Adjustable wrench
Slotted screwdriver	Cross head screwdriver
Stepladder	Forklift
Level	Wire cutting pliers
Claw Hammer	Diagonal cutting pliers
Insulating shoes	Antistatic gloves
Electrician Knife	Cable ties
Insulating Tape	Insulating gloves

Table 3.1 Tools Required (continued)

Name of Tools	
Crimping pliers	Heat shrinkable tube
Insulated torque wrench	Torque screwdriver
Multimeter	Clip-on ammeter

3.2 Dimension and Weights

Figure 3.1 Unit Dimension

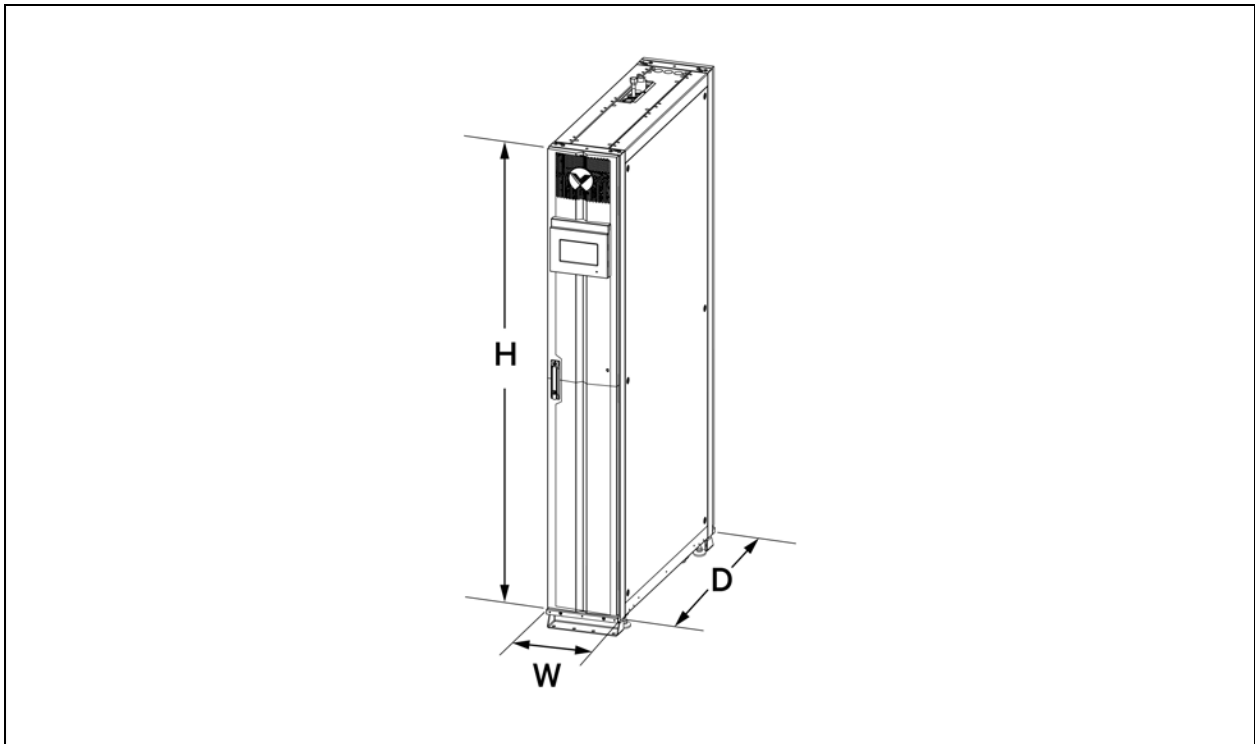

Model	Unit Dimensions (Width x Depth x Height) in. (mm)	Shipping Dimensions (Width x Depth x Height) in. (mm)	Net Weight lb (kg)	Shipping Weight without pallet lb (kg)	Shipping Weight with pallet lb (kg)
CRD030	11.8 x 43.8 x 78.7 (300 x 1114 x 2000)	40 x 60 x 90 (1016 x 1524 x 2298)	421 (191)	564 (256)	654 (297)
CRD040	23.6 x 43.8 x 78.7 (600 x 1114 x 2000)		524 (238)	654 (297)	744 (338)

3.3 Clearance Requirements

Figure 3.2 Vertiv™ CoolPhase Row CRD030 Clearance Requirements (Top View, mm (in.))

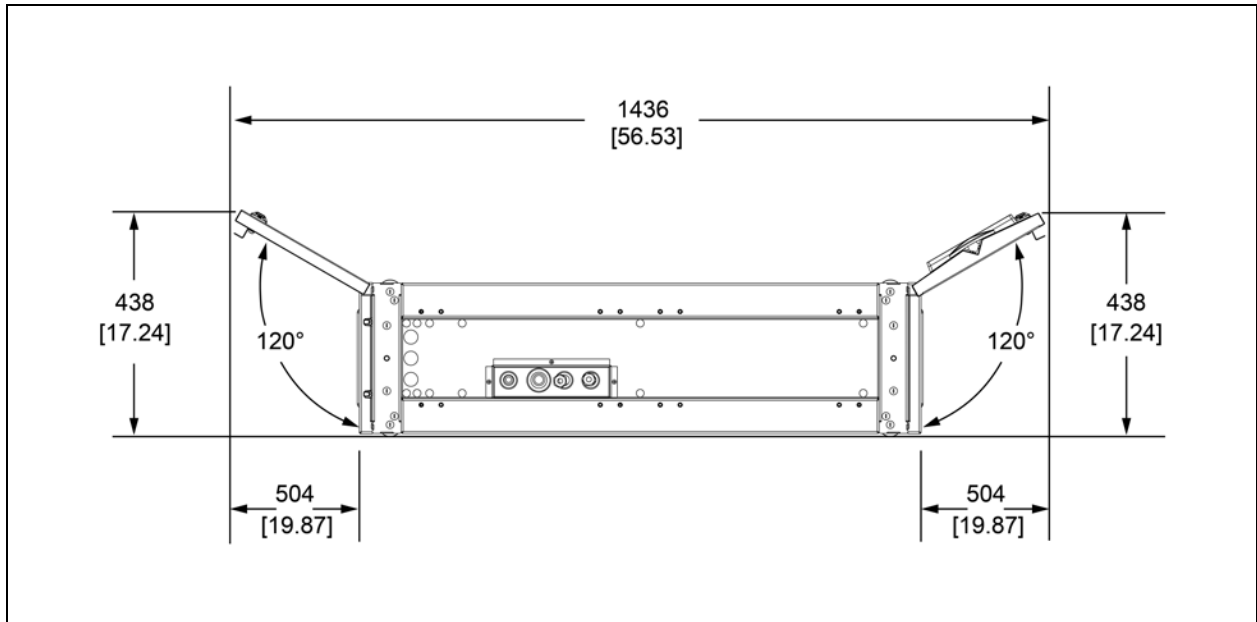
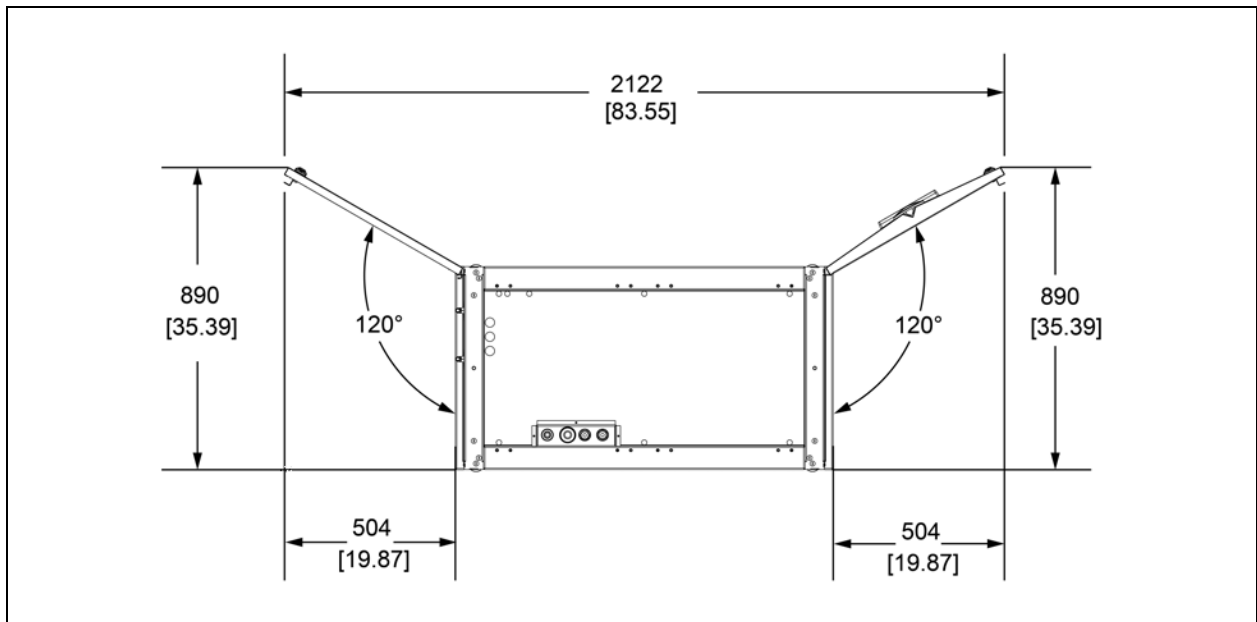

Figure 3.3 Vertiv™ CoolPhase Row CRD040 Clearance Requirements (Top View, mm (in.))



NOTE: Keep space at least 36 in. (915 mm) from the front door and rear door to the wall or to other obstacles for service clearance.

3.4 Inspecting the Unit

Upon arrival of the unit and before unpacking:

- Verify that the labeled equipment matches the bill of lading.
- Inspect that there are no visible or concealed damages on the package.
- Additional inspection of the unit is warranted to ensure no exterior or internal damage.
- Report damage immediately to the carrier and file a damage claim with a copy sent to Vertiv™ or to your sales representative.

3.5 Moving the Packaged Unit

Transport the unit with a forklift or a pallet jack, when using a forklift or pallet jack:

- Make sure forks (if adjustable) are spread to widest allowable distance to still fit under pallet. Make sure fork length is suitable for pallet length. Pallet length is 60" (1524mm).
- Do not tilt the unit more than 20 degrees in any direction to prevent the unit from falling over.
- Packaged unit shall not be lifted any higher than 2"- 4" (51-102mm) off ground when handled. All by-standing personnel shall be no closer than 12' (3.7m) to handled packaged unit.
- If circumstances require unit to be lifted higher than 4" (102mm) great care shall be exercised and all by-standing personnel are to be no closer than 20' (5m) to lift point of unit.
- Refer to the figure below for the location of the center of gravity.

Figure 3.4 Center of Gravity

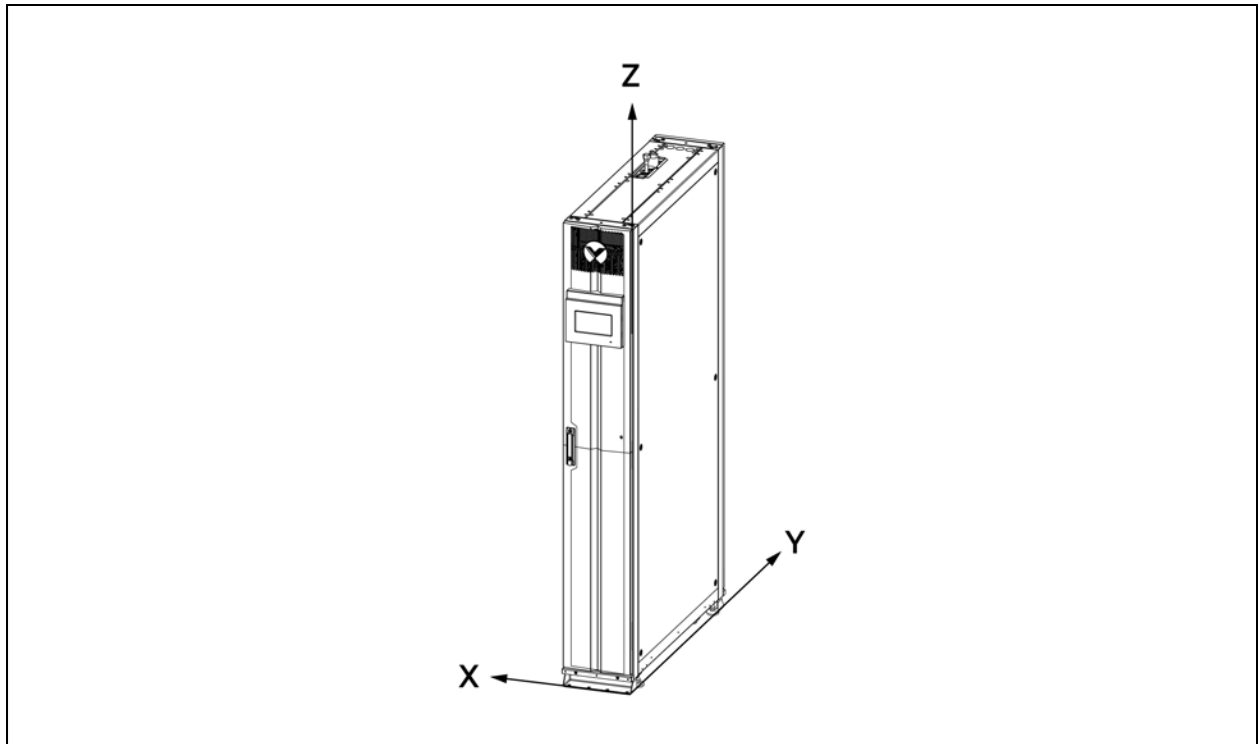

Center of Gravity	X Axis in. (mm)	Y Axis in. (mm)	Z Axis in. (mm)
Distances from Corner	X ± 2 (50)	Y ± 2 (50)	Z ± 3.9 (100)
CRD030	5.8 (148)	22.6 (573)	36.5 (927)
CRD040	10.7 (272)	23 (583)	36.3 (923)

3.6 Unpacking the Unit

The following tools/equipment are required to unpack the unit:

- Safety boots.
- Gloves to avoid splinters when the panels are being handled.
- Forklift or Pallet Jack to move the unit closer to its final location.

Figure 3.5 Unpacking Instructions

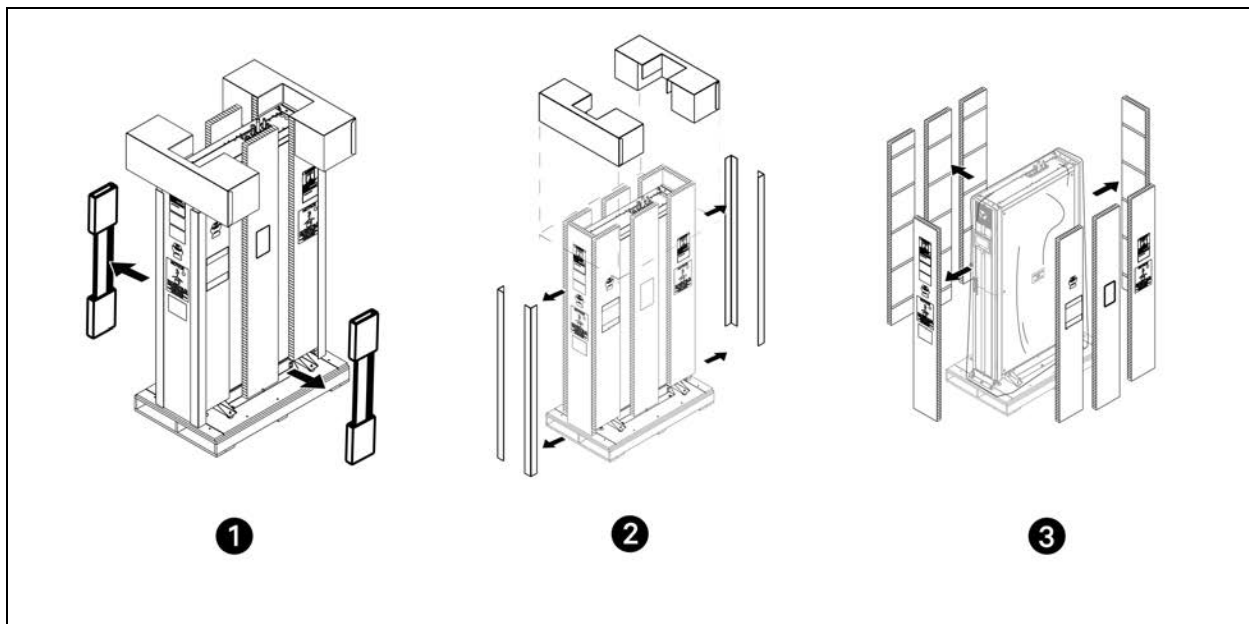

Item	Description	Item	Description
1	Remove the ramps from the unit	3	Remove the honeycomb planks.
2	Remove the top side spacers and the corner protection.	-	-

NOTE: Bag may remain over unit if needed to protect against dirt and/or debris until ready for install. For a better understanding of the unpacking process please refer to Unpacking Instructions for this product. The unpacking instructions is a document attached to the outside of the package. A web version is available on the product's official website.

3.7 Removing the Unit from the Pallet



WARNING! Risk of unsecured unit rolling off pallet. Can cause serious injury or death. Ensure that the unit and pallet are located on a flat surface before loosening the hardware securing the unit to its shipping pallet.



WARNING! The anti-tip outriggers must stay attached to the unit until it's moved and set in its final resting position.



WARNING! Two or more properly trained and qualified personnel are required to move the unit to its installation location.

To remove the unit from the pallet:

1. Remove the screws securing shipping brackets on the side of the unit base using a 13mm socket drive or wrench.
2. Remove lag screws securing shipping brackets to pallet using 9/16" socket drive or wrench. Refer to detail.

Figure 3.6 Removing Shipping Brackets from Pallet

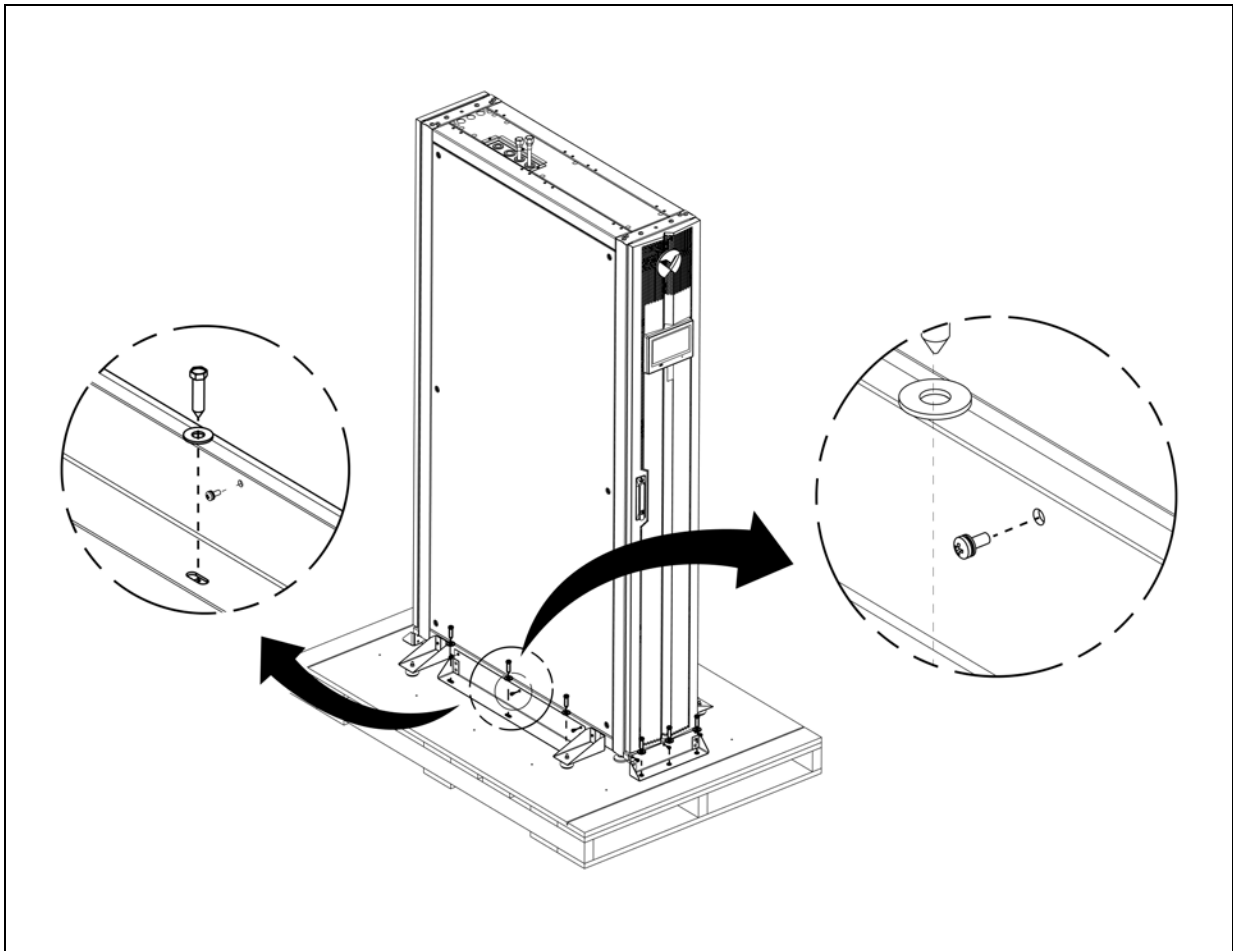

3. Locate and attach ramps to the pallet. Refer to view A for correct placement (Ramp groove guideline).

Figure 3.7 Installing Ramps

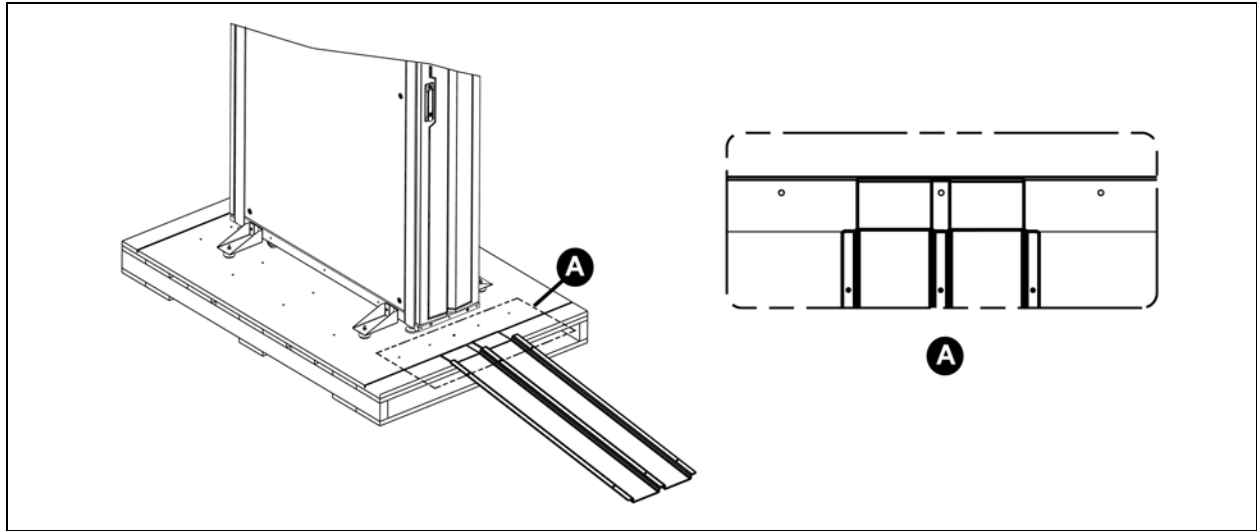

4. Lift the four leveling feet under the unit. Lift the unit one corner at a time.
 - a. Use an adjustable wrench to loosen the fixing nut on each foot in counterclockwise direction.
 - b. Use an adjustable wrench to turn the hex bolt clockwise to adjust feet up.
 - c. Tighten the fixing nut.
5. Move the unit to its installation location using the built-in casters.

NOTE: Take away all plastic wrap, refer to the Handling Instructions of this product to have a better understanding of how to remove the unit from the pallet. The handling instructions is a document attached to the outside of the package. A web version is available on the product's official website.

4 Installing in Enclosure Row

4.1 Leveling the Unit

To level the unit:

1. Use an adjustable wrench to loosen the fixing nut on each foot in counterclockwise direction.
2. Rotate the hex bolt on the base of each foot in clockwise or counterclockwise direction until the foot rises or falls to a suitable position. Use a level to ensure that the cabinet is level.
3. Tighten the fixing nut on each foot.

Figure 4.1 Leveling the Unit

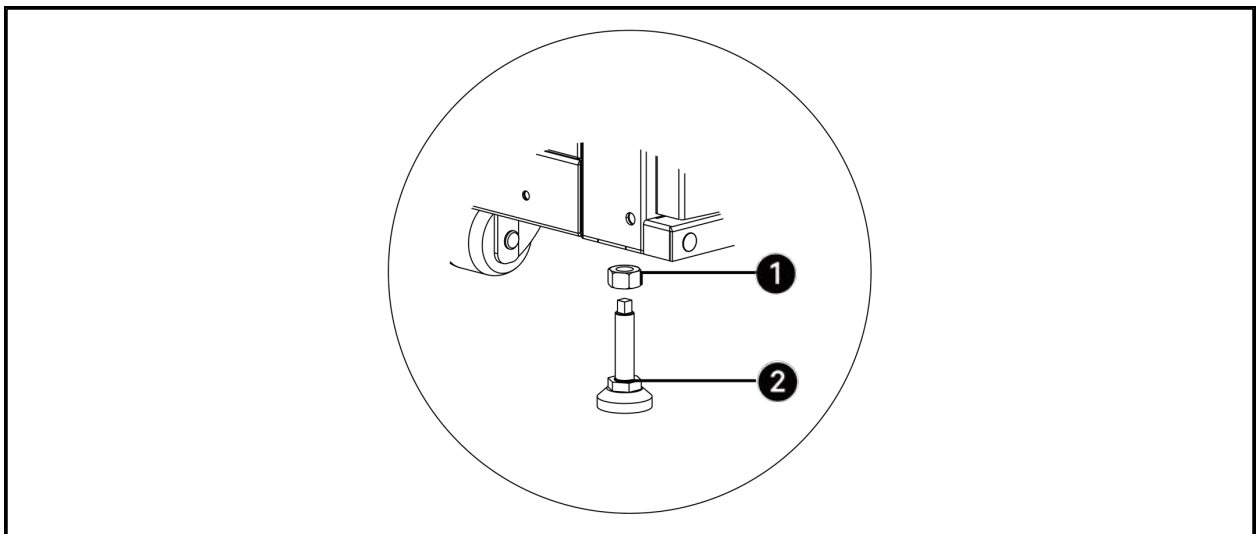

Item	Description
1	Fixing nut hex M12
2	Hex bolt M12 x 4"

4.2 Combining the Unit with Adjacent Cabinets

Eight baying brackets are provided with the unit. Use four for the front side and four for the rear side.

To combine the unit with adjacent cabinets:

1. Open the front door. Install two baying brackets with M6 x 10 countersunk screws on the left frame. Fix each screw on position A. Install two baying brackets with M6 x 10 countersunk screws on the right frame. Fix each screw on position B.
2. Open the rear door and install two baying brackets the same way as for the front door.

Figure 4.2 Installing the Baying Brackets

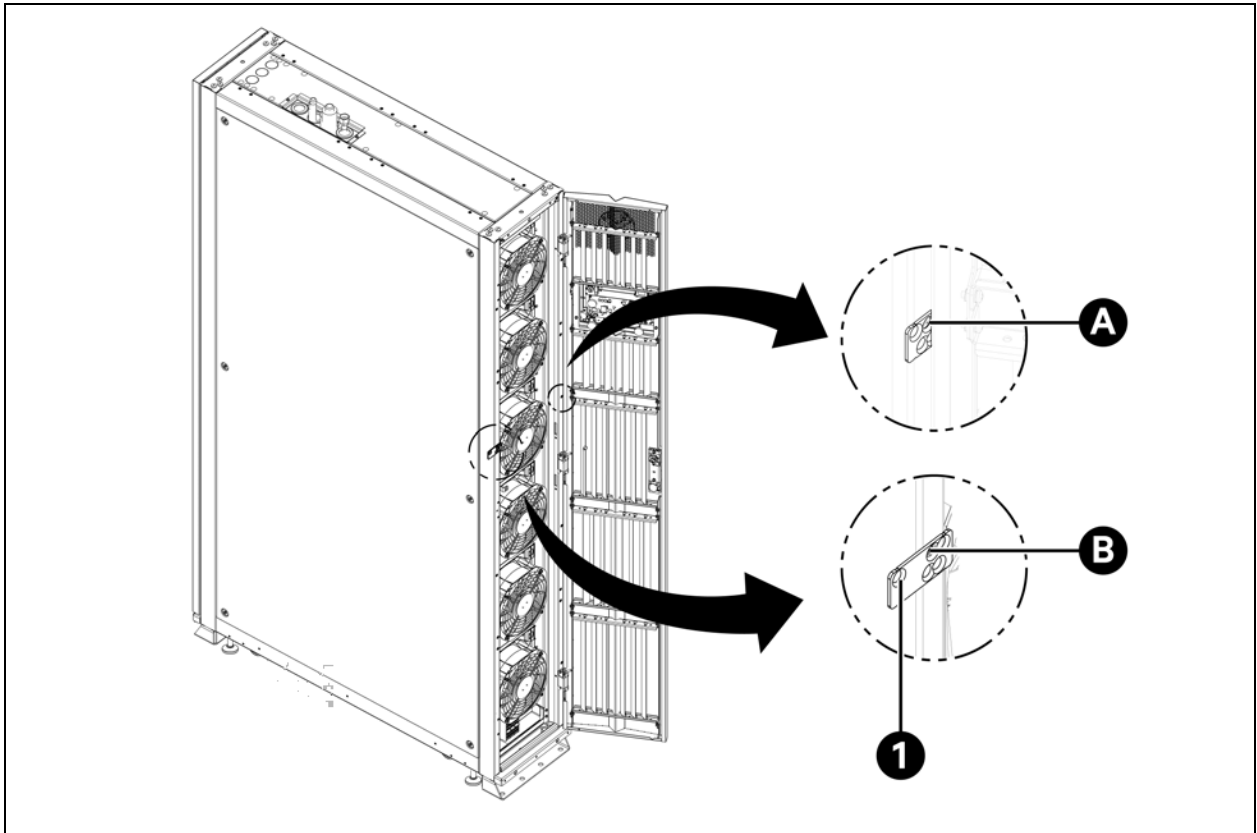

Item	Description	Item	Description
1	Baying bracket (4)	B	Position to install the screw on the left frame
A	Position to install the screw on the right frame	-	-

4.3 Location of the Main Grounding Point (PE)

The main grounding point is located on the top panel, as shown in Figure 4.3 .

Figure 4.3 Location of the Main Grounding Point

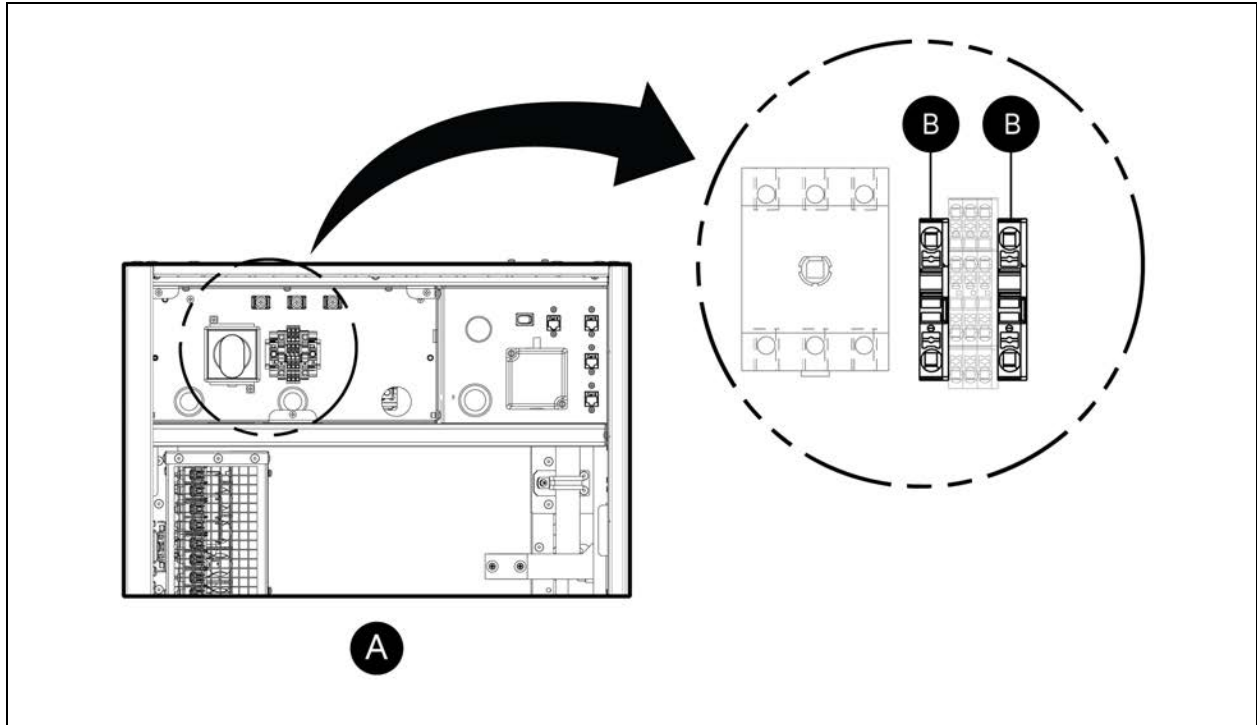

Item	Description
A	Rear side of the rack
B	Main grounding point

4.4 Remove Filters

To remove filters:

1. Open the rear door.
2. Remove filters.
 - a. Remove the upper Filter holder by unscrewing the two M4 x10 screws.
 - b. Remove the upper filter.
 - c. Remove the lower filter holder by unscrewing the two M4 x10 screws.
 - d. Remove the lower filter holder.

Figure 4.4 Removing the Upper and Lower Filters

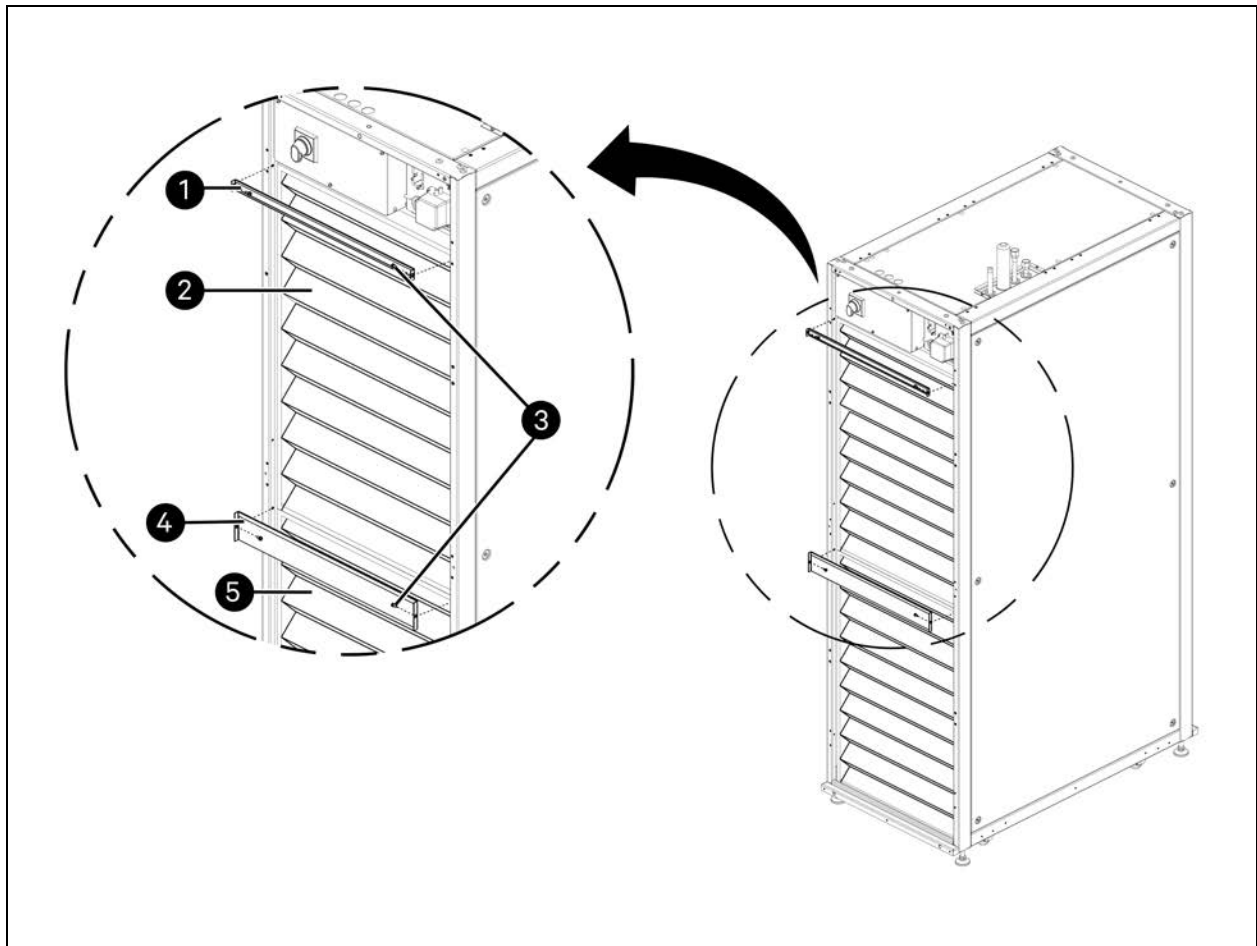

Item	Description	Item	Description
1	Upper filter holder	4	Lower Filter holder
2	Upper Filter	5	Lower Filter
3	M4 x 10 screws (4)	-	-

4.5 Installing Top Frame and Front Frame (Optional)

The unit can be installed with only the top frame, or it can be installed with both the top frame and front frame.

4.5.1 Installing the Top Frame without the Front Frame

Figure 4.5 CoolPhase Row CRD030 - Dimensions of the Top Frame

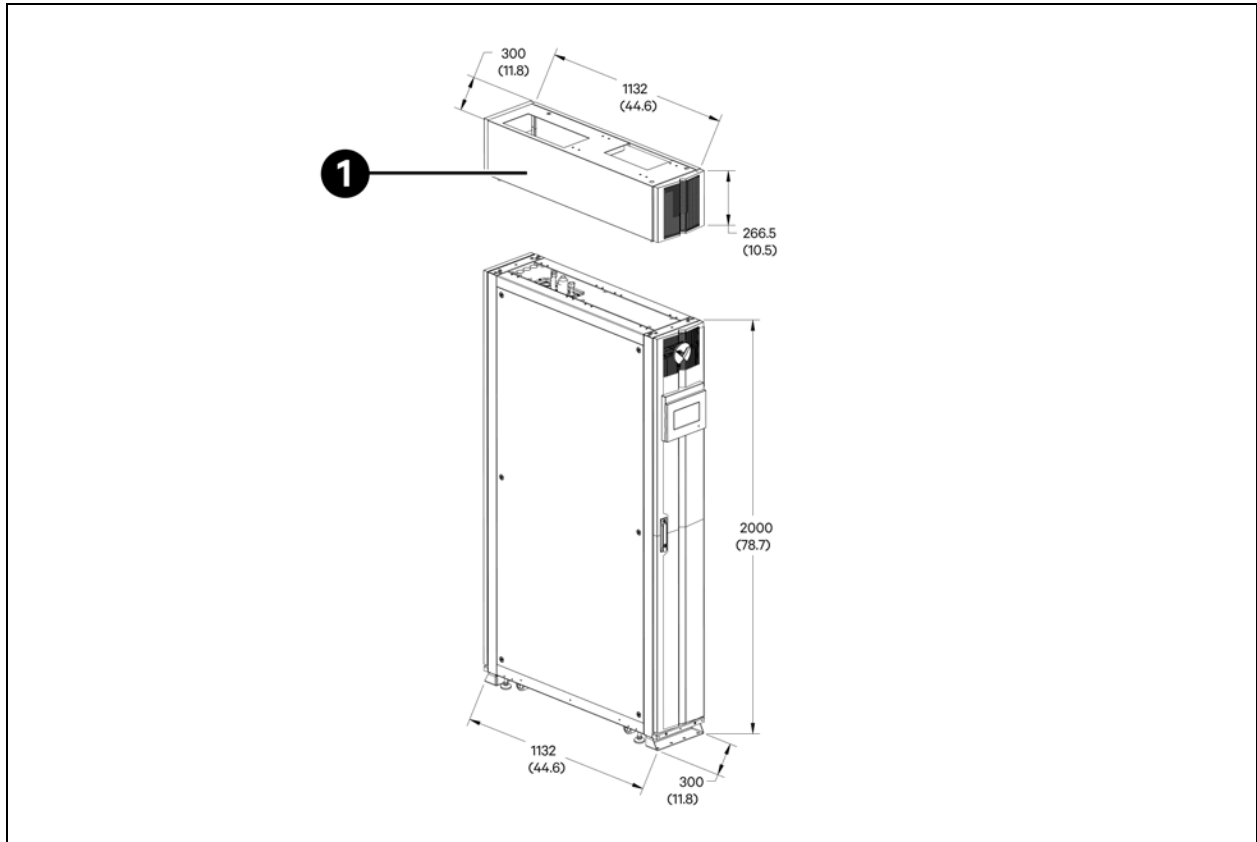

Item	Description
1	Top frame
NOTE: All dimensions are in mm (in.).	

Figure 4.6 CoolPhase Row CRD040 - Dimensions of the Top Frame

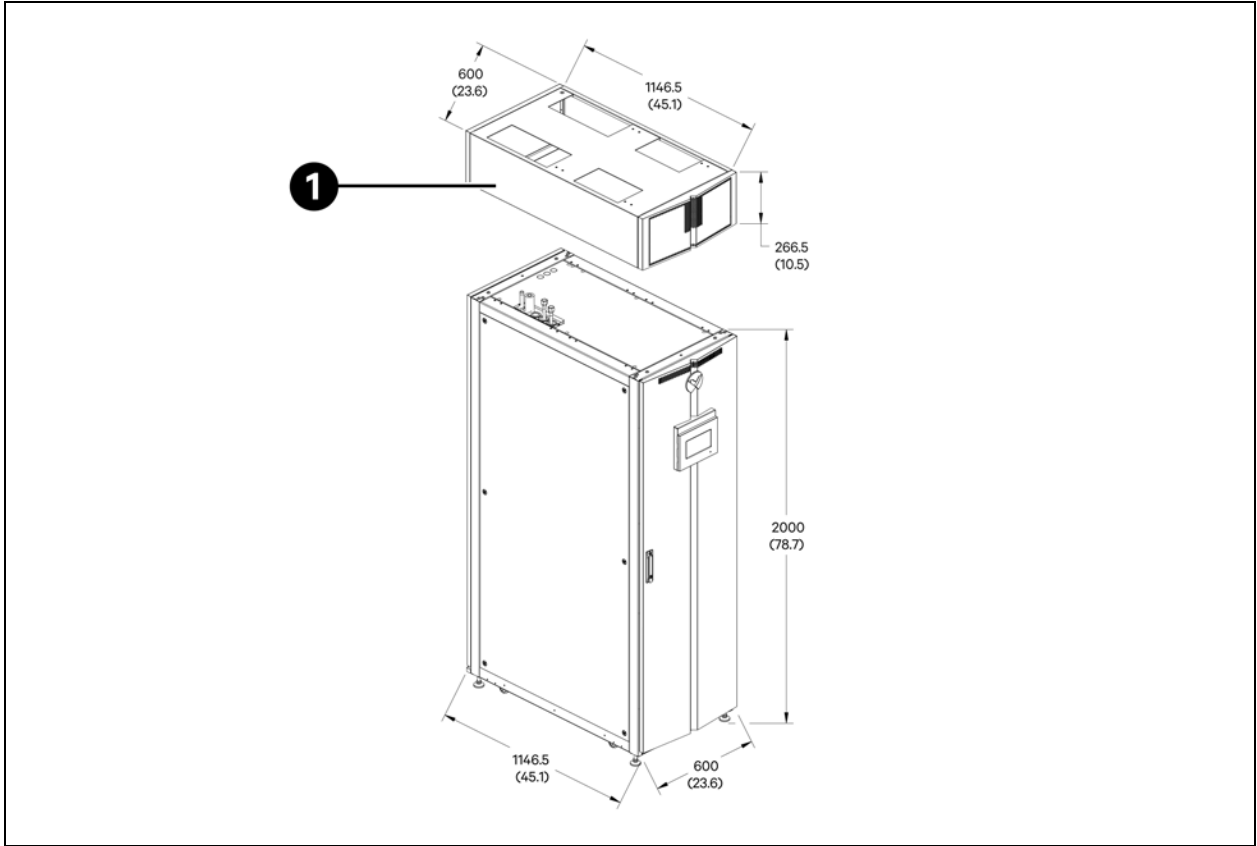

Item	Description
1	Top frame
NOTE: All dimensions are in mm (in.).	

1. Install the top frame and fixed it with four M12 × 30 screws, four M12 Lock ZP Washer and four M12 Flat ZP Washer.
2. Move the V logo to the top frame.

Figure 4.7 Installing the Top Frame without the Front Frame (CoolPhase Row CRD040 as an Example)

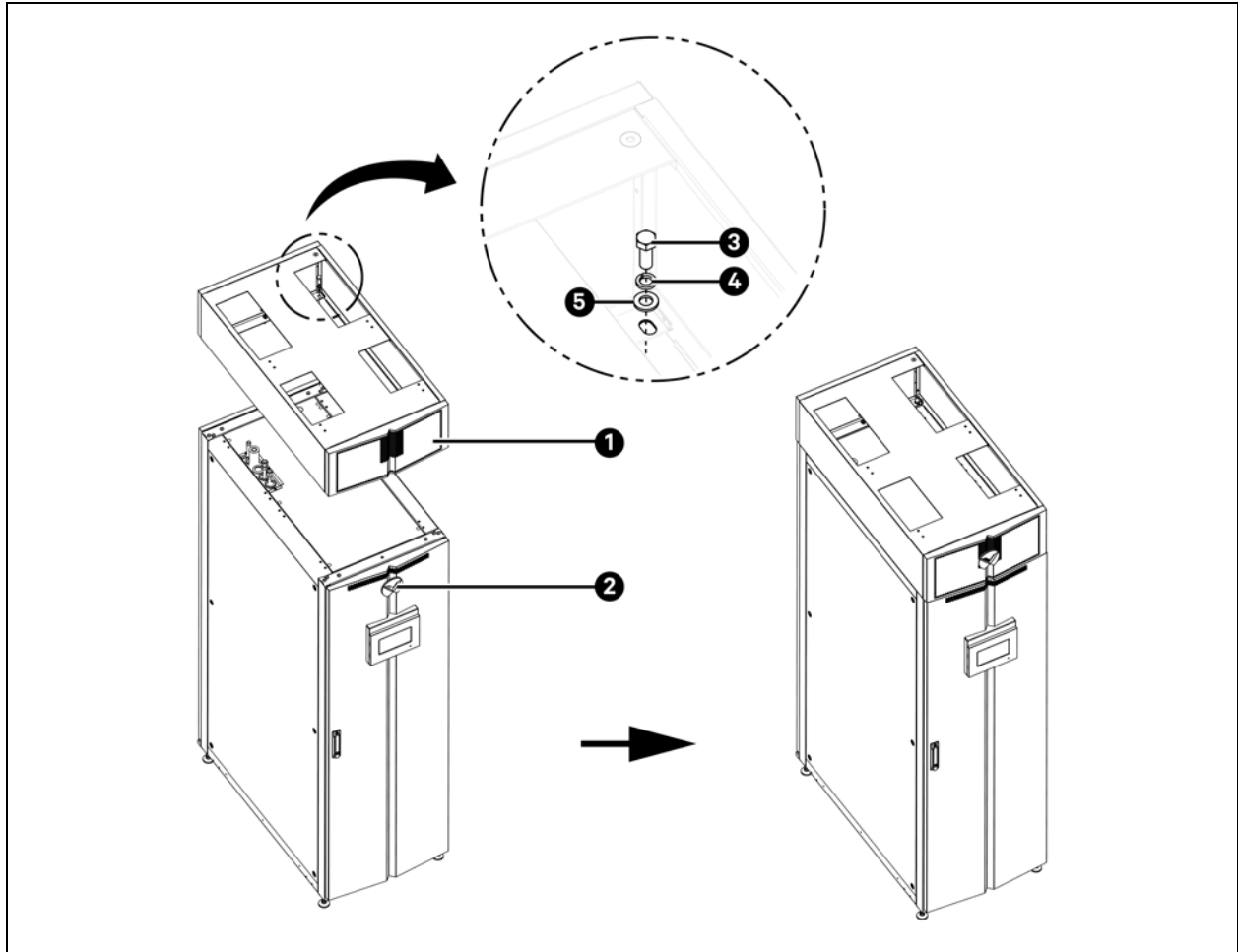

Item	Description	Item	Description
1	Top frame	4	M12 Lock ZP Washer
2	V Logo	5	M12 Flat ZP Washer
3	M12 x 30 screw	-	-

NOTE: After the top frame is installed, use plastic caps to cover the unused holes on the top plate.

4.5.2 Installing the Top Frame and the Front Frame

Figure 4.8 CoolPhase Row CRD030 - Dimensions of the Top Frame and the Front Frame

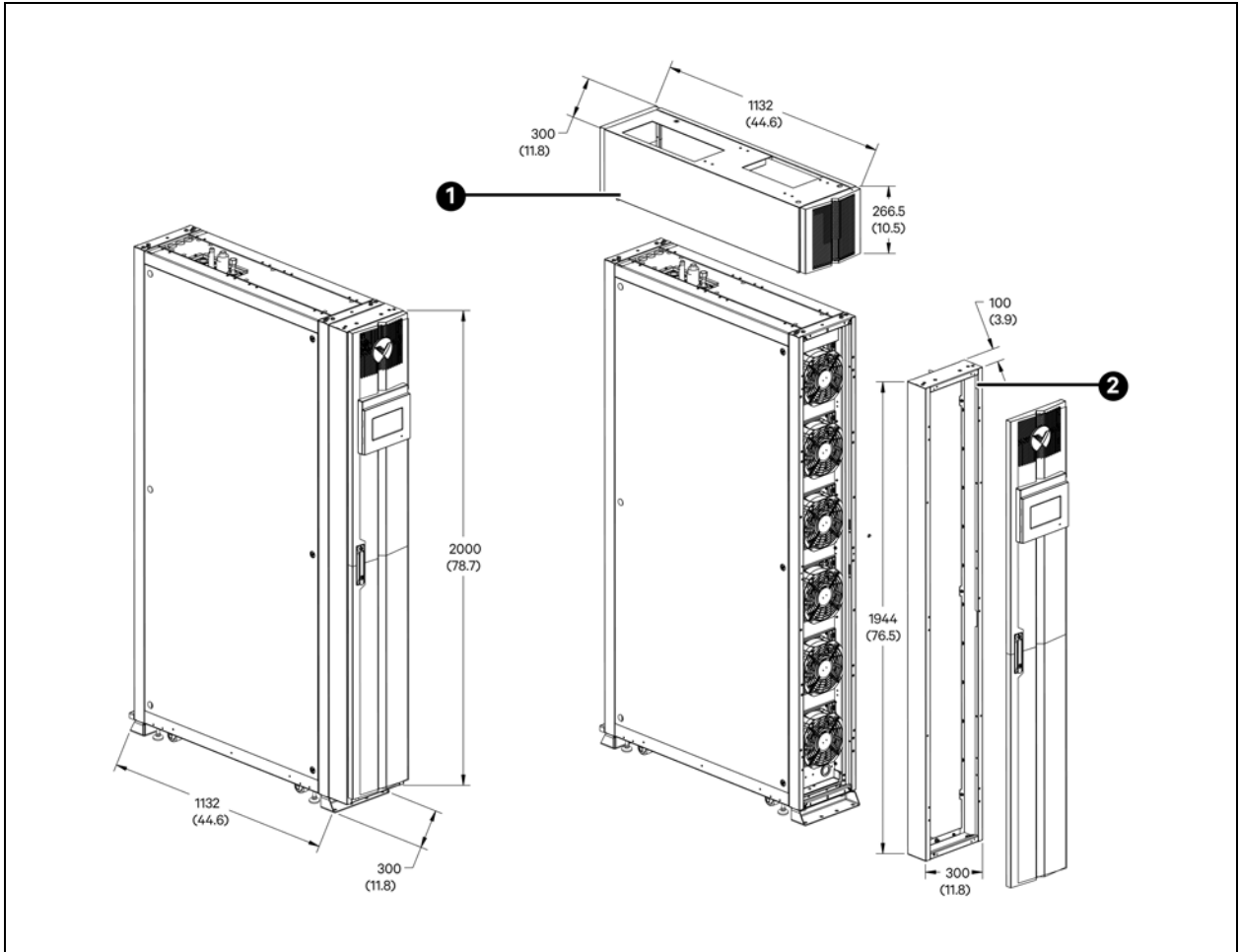

Item	Description
1	Top frame
2	Front frame

NOTE: All dimensions are in mm (in.).

Figure 4.9 CoolPhase Row CRD040 - Dimensions of the Top Frame and the Front Frame

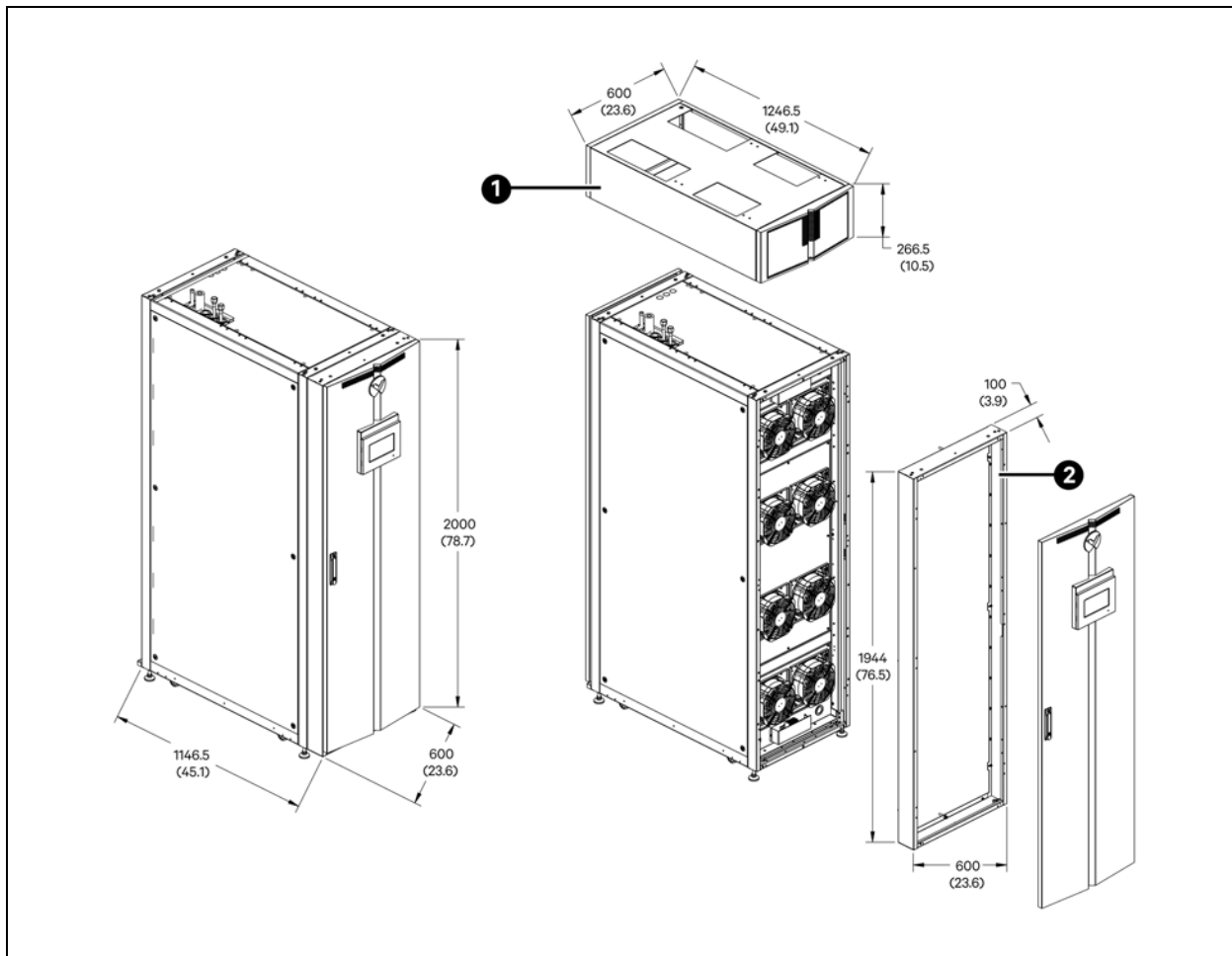

Item	Description
1	Top frame
2	Front frame

NOTE: All dimensions are in mm (in.).

To install the top frame and the front frame:

1. Open the front door, disconnect the grounding cable from the front door by removing the M4 screw. Disconnect the power cable and the communications cable from the HMI by unplugging the two connectors from the PWR port and the CAN1 port.
2. Remove the front door by removing three hinges that connect the door to the vertical post.
 - a. Remove the circlip from the bottom of each hinge using a needle nose pliers.
 - b. Take out the pin from each hinge.
 - c. Remove two M6 Philips head screws from each hinge.

Figure 4.10 Removing the Front Door (CoolPhase Row CRD040 as an Example)

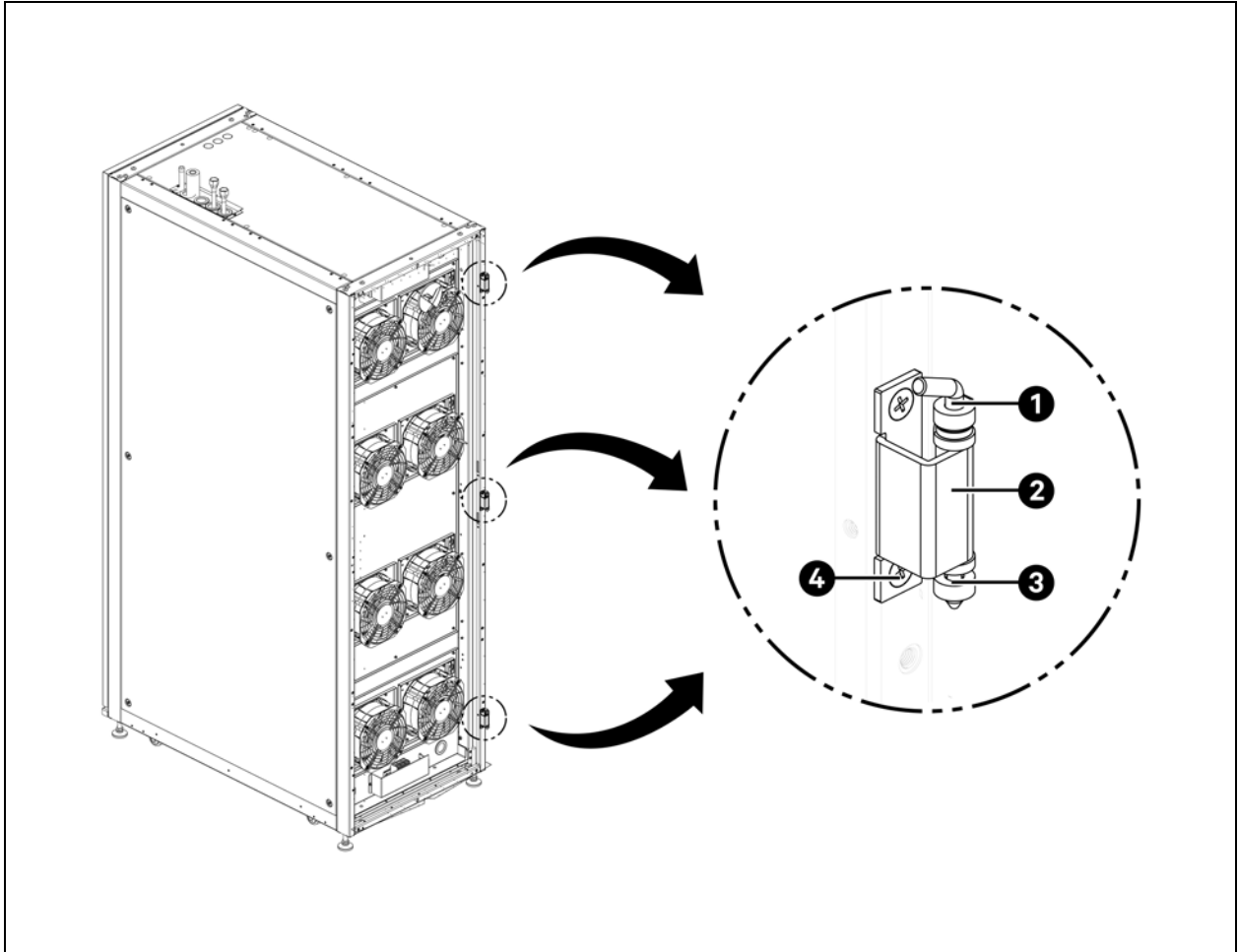

Item	Description	Item	Description
1	Pin	3	Circlip
2	Door Hinge	4	M6 Philips head screw

3. Install the front frame to the unit with ten M5 × 12 screws (six on the left and right frames and four on the top and bottom frames) and then the M8X40 screws (one on each top and bottom frame)

Figure 4.11 Installing the Front Frame (CoolPhase Row CRD040 as an Example)

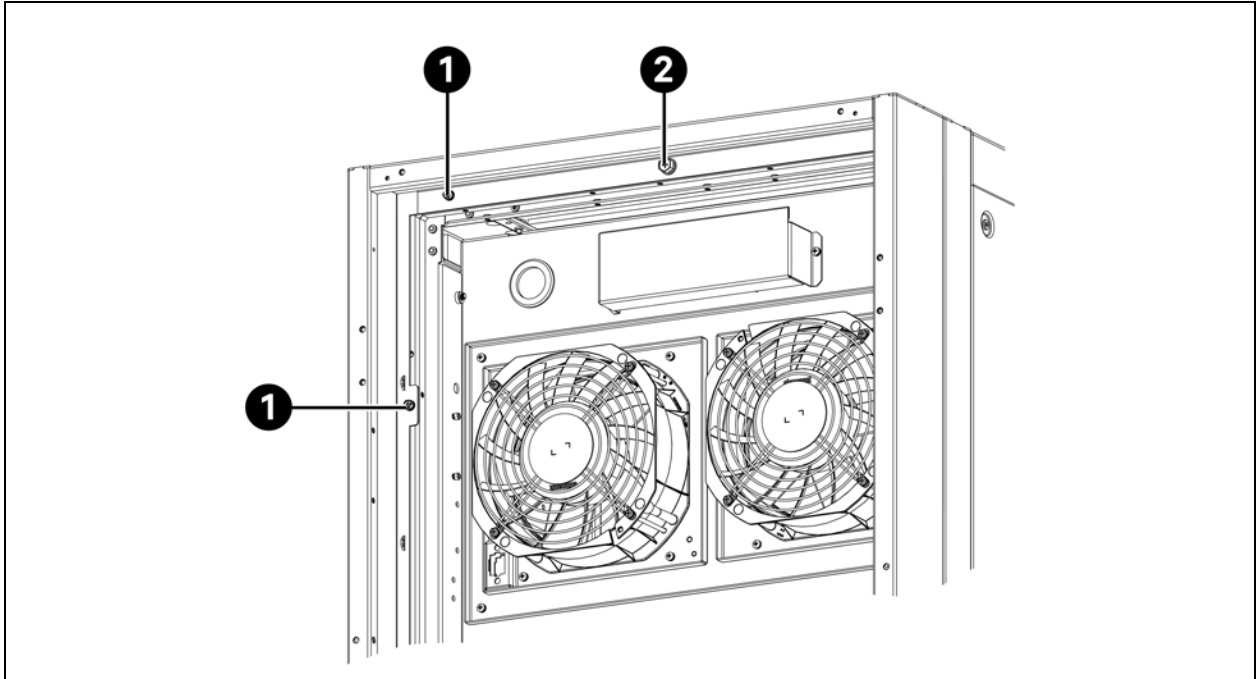

Item	Description
1	M5 × 12 screws, 2 for each top and bottom frame and 3 on each side frame
2	M8 × 40 screws, 1 for each top and bottom frame

4. Install the top frame on the top panel of the unit with four M12 × 30 screws, four M12 Lock ZP Washer and four M12 Flat ZP Washer.

Figure 4.12 Installing the Top Frame (CoolPhase Row CRD040 as an Example)

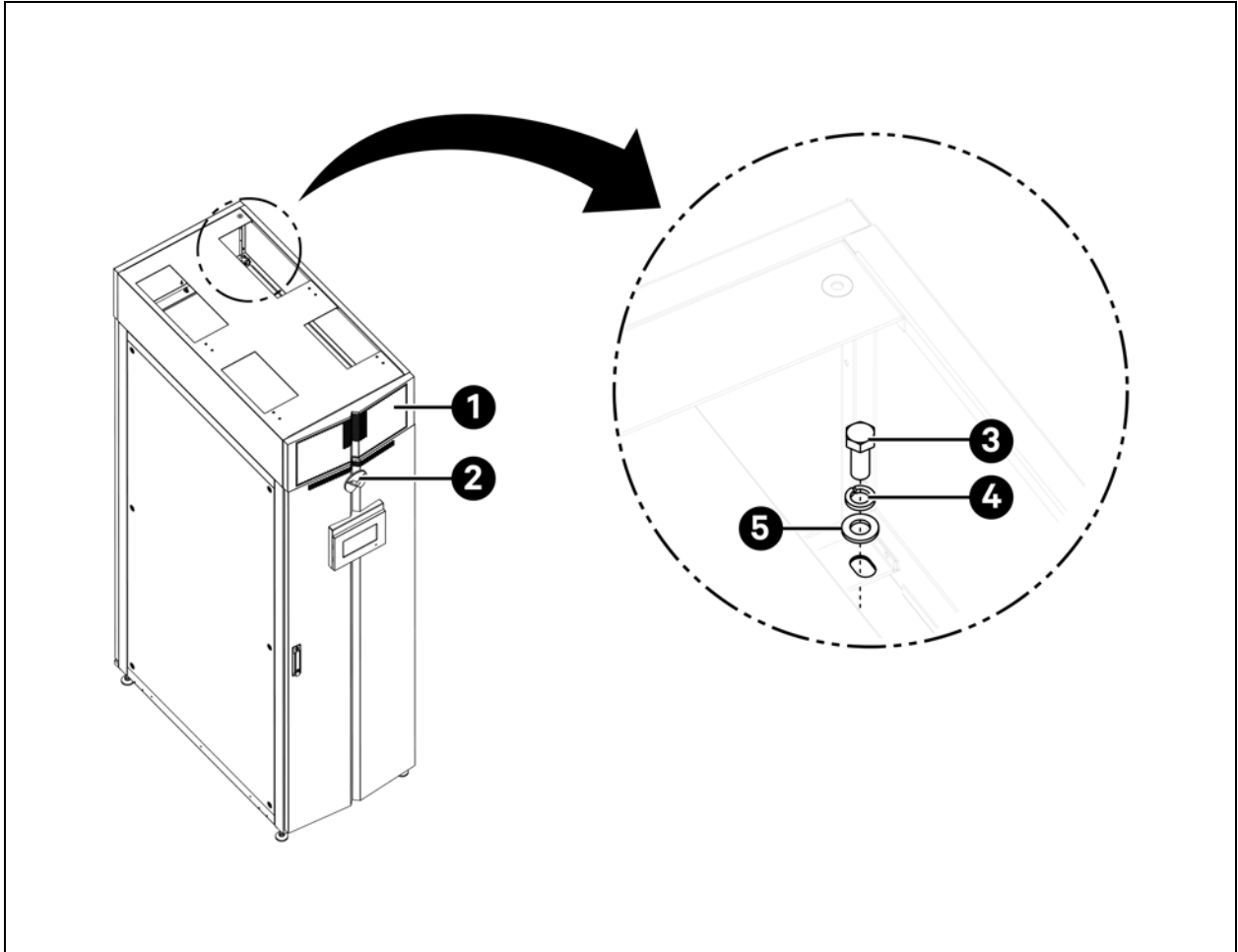

Item	Description	Item	Description
1	Top frame	4	M12 Lock ZP Washer
2	V Logo	5	M12 Flat ZP Washer
3	M12 × 30 screw	-	-

5. Install back the front door. Connect the power cable and communications cable to the HMI.
6. Move the V logo to the top frame.

NOTE: After the top frame is installed, use plastic caps to cover the unused holes on the top plate.

This page intentionally left blank

5 Piping and Refrigeration Connections

- Installation of pipework shall be kept at minimum.
- Pipework must be installed so that it is protected from physical damage and must not be in located in unventilated areas.
- Pipework shall be done following national and local codes such as ASHRAE 15, ASHRAE 15.2, IAPMO Uniform Mechanical Code, ICC International Mechanical Code, or CSA B52.
- All field joints shall be accessible for inspection prior being covered or enclosed.
- Mechanical filed joints shall remain accessible after installation for maintenance and servicing purposes.
- Precautions must be taken to avoid excessive vibration or pulsation to refrigerating piping.
- Protection devices, piping and fittings must be protected as far as possible against adverse environmental effects, for example, the danger of water collecting and freezing in relief pipes or the accumulation of dirt and debris.
- Provision must be made for expansion and contraction of long runs of piping.
- Piping in Refrigerating Systems shall be so designed and installed to minimize the likelihood hydraulic shock damaging the system.
- Steel pipes and components shall be protected against corrosion with a rustproof coating before applying any insulation.
- Flexible pipe elements must be protected against mechanical damage, excessive stress by torsion, or other forces. They should be checked for mechanical damage annually.
- After the completion of field piping, pipework must be pressure tested with an inert gas and then vacuum tested prior to refrigerant charging, testing shall be done as follow:
 - The system shall be tested according the low-side maximum allowable pressure.
 - Field-made refrigerant joints indoors shall be tightness tested with a method having a sensitivity of 5 grams per year of refrigerant or better under a pressure of at least 0.25 times the maximum allowable pressure. No leak shall be detected.



WARNING! Risk of over-pressurization of the refrigeration system. Can cause explosive discharge of high-pressure refrigerant, loss of refrigerant, environmental pollution, equipment damage, injury, or death. This unit contains fluids and gases under high pressure. Use extreme caution when charging the refrigerant system. Do not pressurize the system higher than the design pressure marked on the unit's nameplate.



CAUTION: Risk of excessive refrigerant line pressure. Can cause tubing and component rupture resulting in equipment damage and personal injury. Do not close off the refrigerant-line isolation valve for repairs unless a pressure-relief valve is field- installed in the line between the isolation valve and the check valve. The pressure-relief valve must be rated 5% to 10% higher than the system-design pressure. An increase in ambient temperature can cause the pressure of the isolated refrigerant to rise and exceed the system-design pressure rating (marked on the unit nameplate).

NOTICE

Risk of oil contamination with water can cause equipment damage. Vertiv™ CoolPhase Row systems require the use of PVE (Polyvinyl Ether) oil. Because water is the enemy of a reliable refrigeration system, extreme care must be used when opening systems during installation or service. Even though PVE oil absorbs water at a much slower rate when exposed to air than previously used oils. If water is absorbed into the PVE oil, it will not be easily removed and will not be removed through the normal evacuation process. If the oil is too wet, it may require an oil change and a deep vacuum to remove moisture. PVE oils also have a property that makes them act as a solvent in a refrigeration system. Maintaining system cleanliness is extremely important because the oil will tend to bring any foreign matter back to the compressor.

NOTICE

Improper refrigerant charging can cause equipment damage. Refrigerant charge must be weighed into air-cooled compressorized systems before they are started. Starting rotatory compressors without proper refrigerant charging can cause premature compressor failure.

NOTICE

Specify water quality here for this operation and if potable water source is used for the equipment water supply shall be protected against back siphonage by the equipment.

NOTICE

Risk of improper refrigerant charging. Can cause equipment damage. Refrigerant charge must be weighed into air-cooled compressorized systems before they are started. Starting rotatory and digital rotatory compressors without proper refrigerant charging can cause the compressors to operate at less than $-15\text{ }^{\circ}\text{C}$ ($5\text{ }^{\circ}\text{F}$) evaporator temperature and at less than 138 kPa (20 psig). Operation for extended periods at less than 138 kPa (20 psig) can cause premature compressor failure.

5.1 General Arrangement

Figure 5.1 General Arrangement Diagram

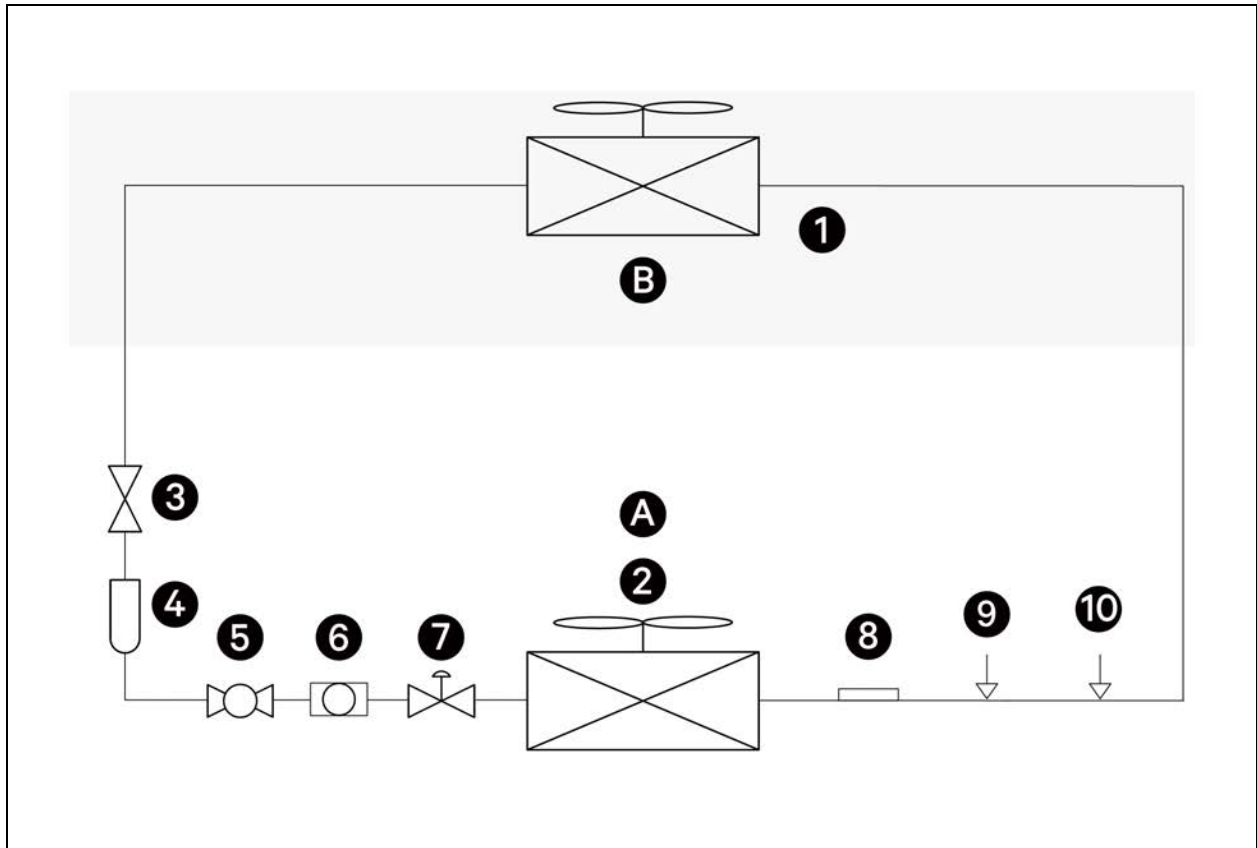

Item	Description	Item	Description
A	Indoor	5	Ball Valve
B	Outdoor	6	Sight Glass
1	CoolPhase Condensing Unit	7	Electronic Expansion Valve
2	CoolPhase Row Evaporator Unit	8	Suction Temperature Sensor
3	Safety Shut Off Valve (SSOV)	9	Suction Pressure Transducer
4	Filter Drier	10	Schrader Service Valve w/Core

Figure 5.2 CoolPhase Condensing Unit Placed Higher than the Evaporator.

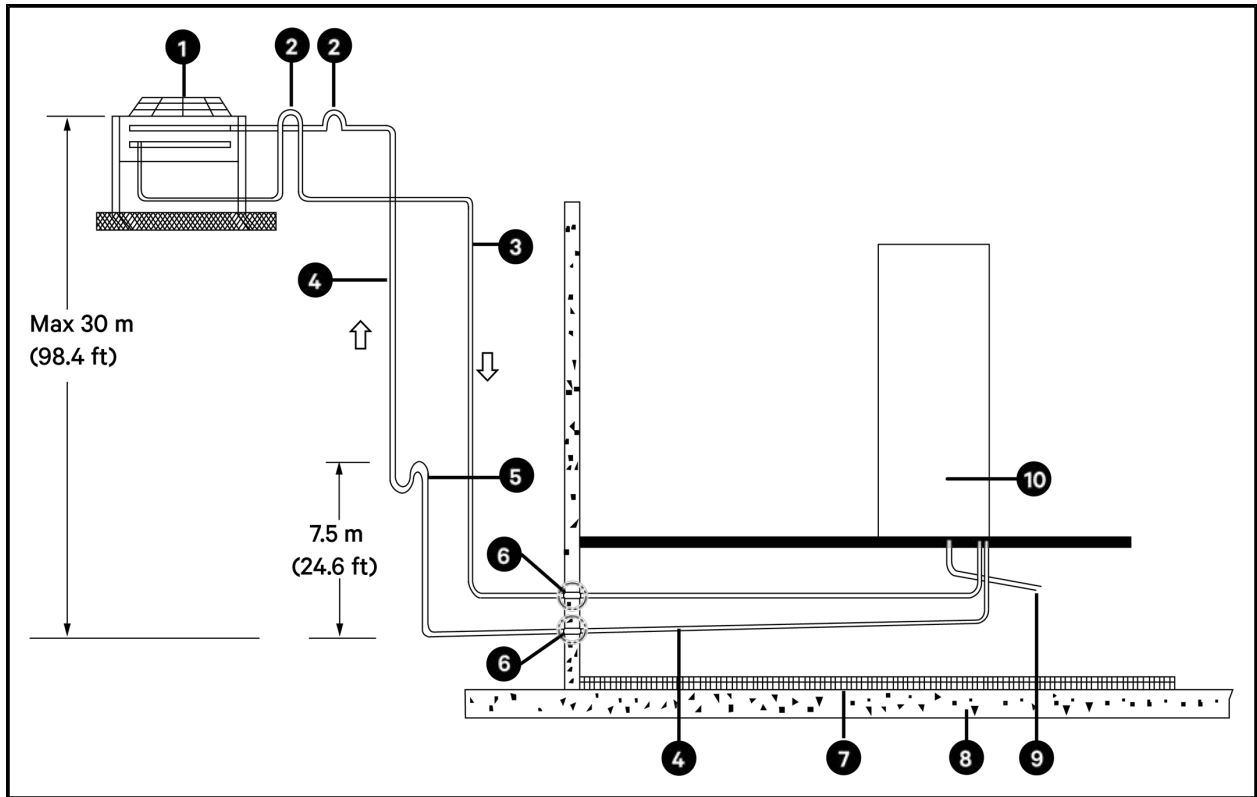

Item	Description	Item	Description
1	CoolPhase Condensing Unit (outdoor)	6	The gap between the pipe and the wall needs to be sealed
2	Inverted Trap	7	Heat insulation floor
3	Liquid Pipe	8	Floor
4	Gas Pipe	9	Condensate pipe
5	Oil Trap	10	CoolPhase Row Evaporator (indoor)

NOTE: The unit can be top piped as well.

NOTE: It is recommended to still set two inverted traps even with low ambient version installed.

NOTE: If the CoolPhase Condensing Unit is installed higher than the evaporator, install an inverted trap in the gas pipe and the liquid pipe of the condenser, to prevent liquid refrigerant from flowing back once the condenser stops. The top end of the inverted trap must be at least 5.9 in (150 mm) higher than the pipe of the condenser. Install an oil trap every 24.6 ft (7.5 m) of the vertical gas pipe.

Figure 5.3 CoolPhase Condensing Unit Placed Lower than the Evaporator.

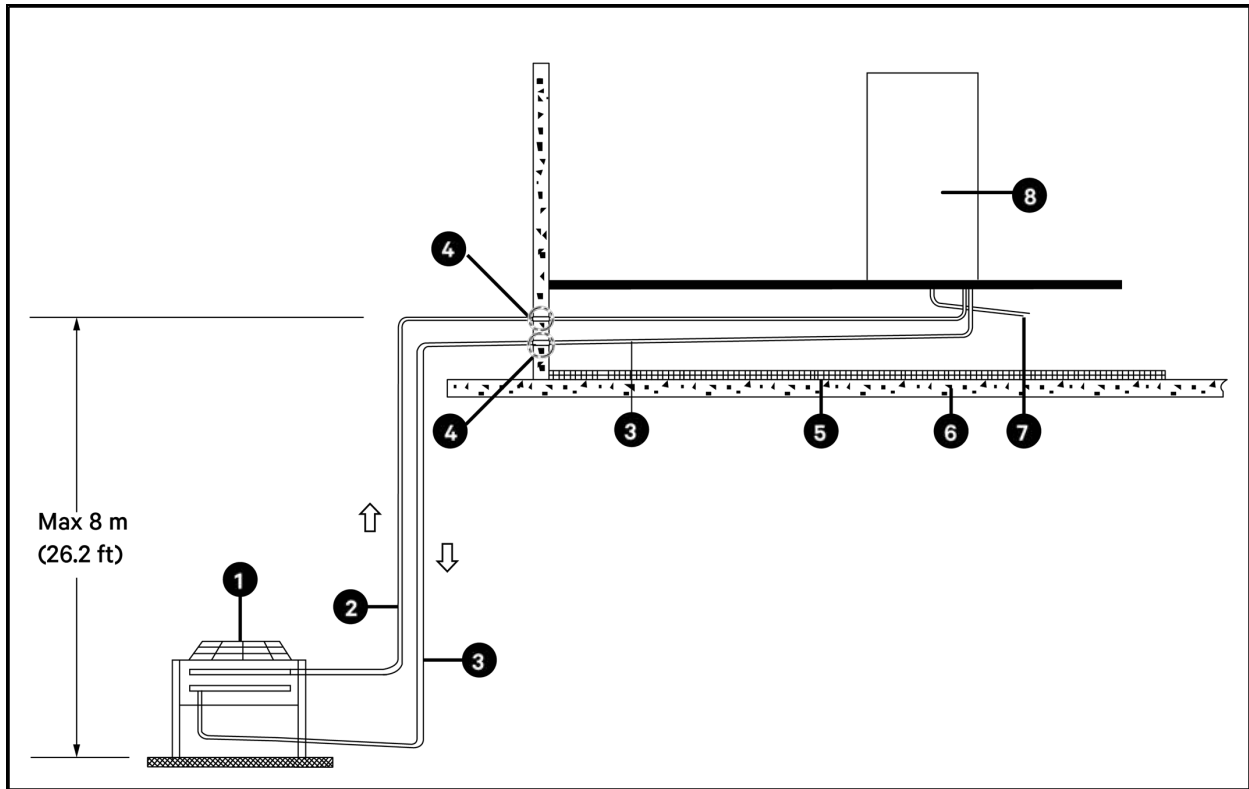

Item	Description	Item	Description
1	CoolPhase Condensing Unit (outdoor)	5	Heat insulation floor
2	Liquid Pipe	6	Floor
3	Gas Pipe	7	Condensate pipe
4	The gap between the pipe and the wall needs to be sealed	8	CoolPhase Row Evaporator (indoor)

NOTE: The unit can be top piped as well.

Figure 5.4 CoolPhase Row CRD030 - Location and Dimension of Pipe and Cable Outlets on Top Plate and Base Plate

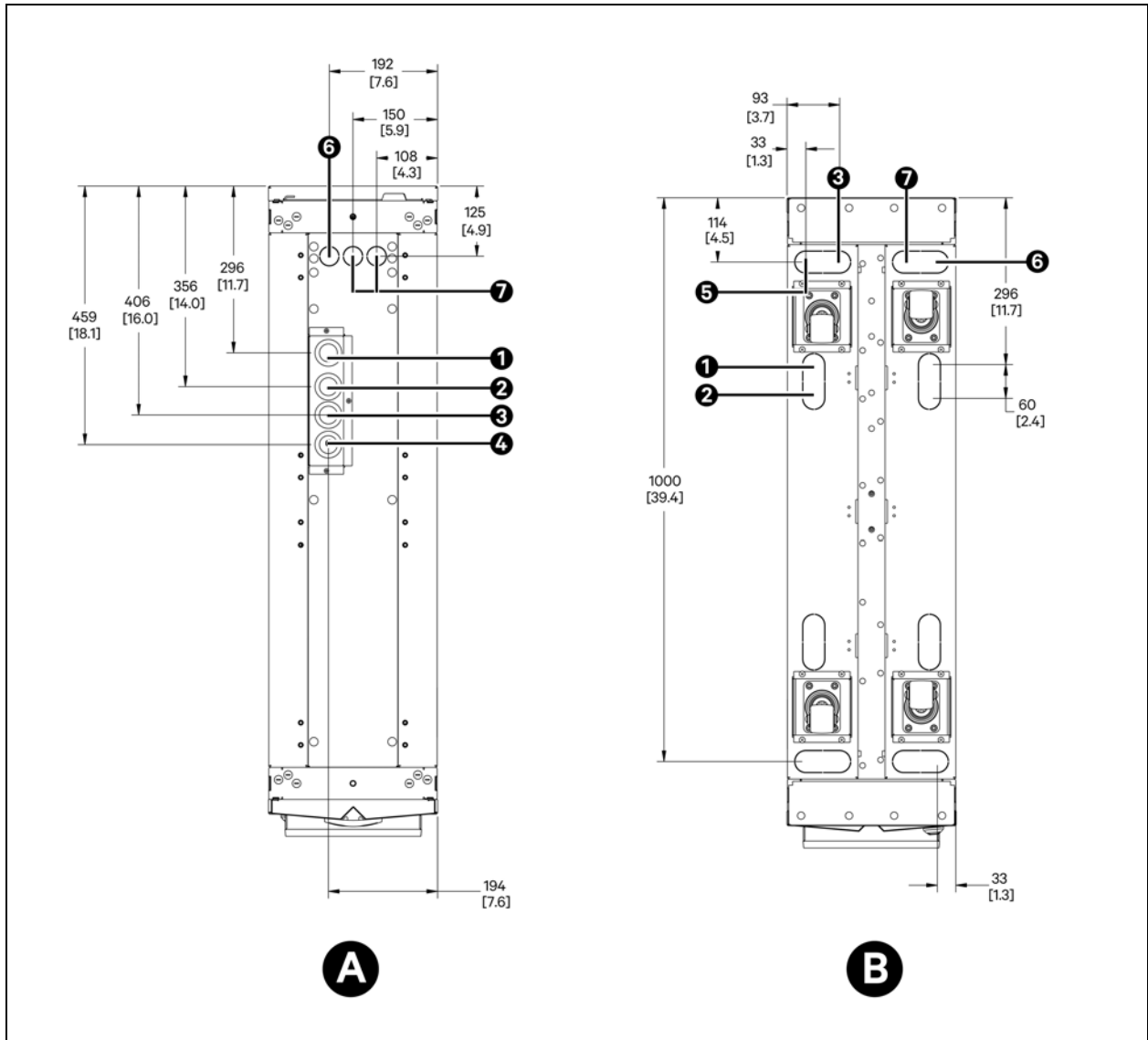

Item	Description		
A	Top Plate		
B	Bottom Plate		
1	RLT	Refrigerant liquid line inlet	5/8 in. O.D. copper sweat
2	RGT	Refrigerant gas line outlet	7/8 in. O.D. copper sweat
3	HS	Humidifier Supply	1/2 in. O.D. copper sweat
4	CPT	Condensate pump outlet	1/2 in. O.D. copper sweat
5	CGT	Condensate gravity outlet	1/2 in. O.D. copper sweat

Item	Description		
6	HVT	High Voltage Cable access	Combination knockout: 28 mm (1-1/8 in.)
7	LVT	Low Voltage cable access	Combination knockout: 28 mm (1-1/8 in.)

NOTE: All dimensions are in mm (in.).

Figure 5.5 CoolPhase Row CRD040 - Location and Dimension of Pipe and Cable Outlets on Top Plate and Base Plate

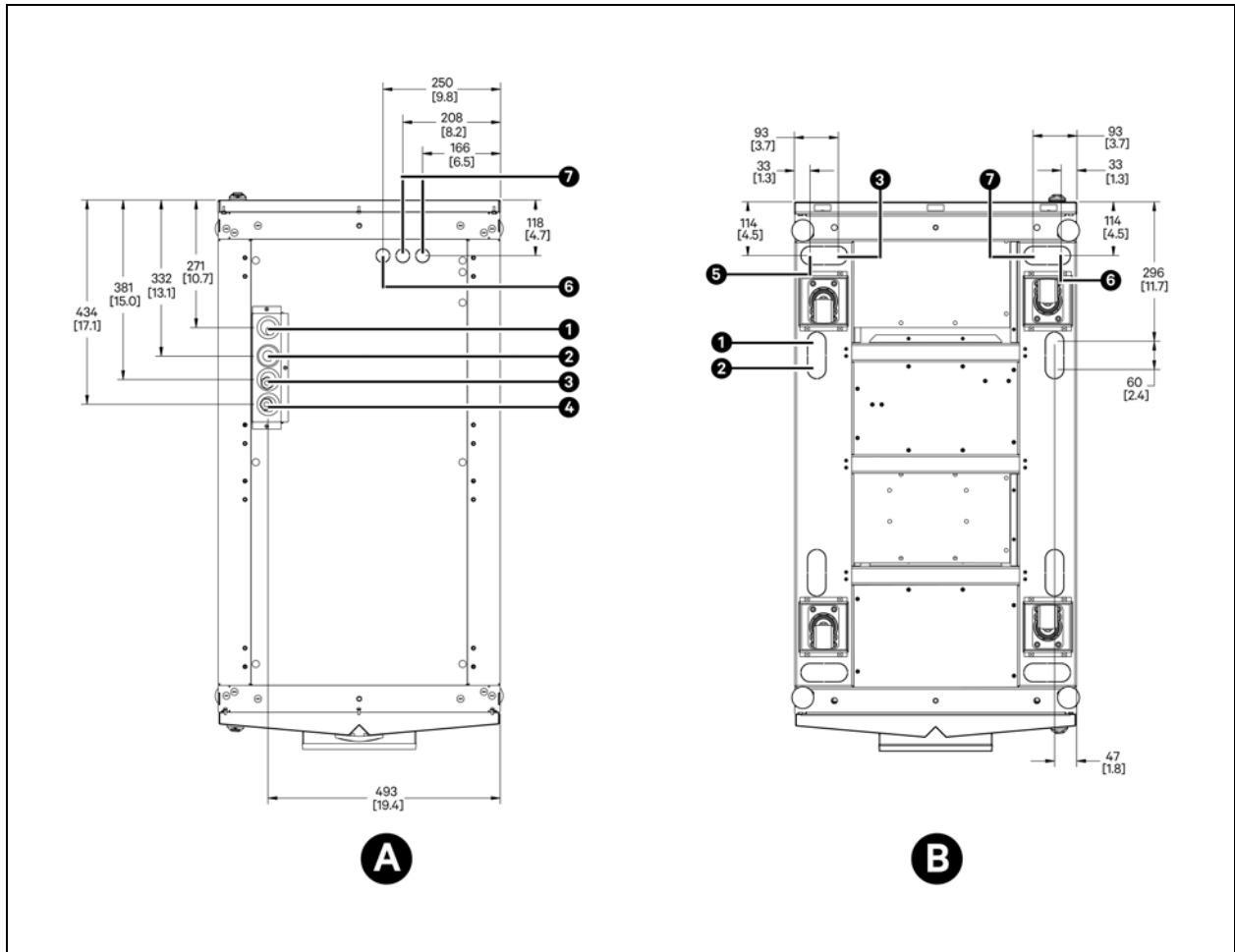

Item	Description		
A	Top Plate		
B	Bottom Plate		
1	RLT	Refrigerant liquid line inlet	5/8 in. O.D. copper sweat
2	RGT	Refrigerant gas line outlet	7/8 in. O.D. copper sweat
3	HS	Humidifier Supply	1/2 in O.D. copper sweat
4	CPT	Condensate pump outlet	1/2 in O.D. copper sweat
5	CGT	Condensate gravity outlet	1/2 in O.D. copper sweat

Item	Description		
6	HVT	High Voltage Cable access	Combination knockout: 28 mm (1-1/8 in.)
7	LVT	Low Voltage cable access	Combination knockout: 22 mm (7/8 in.)
NOTE: All dimensions are in mm (in.).			

Table 5.1 Vertical Distance between Condenser and Evaporator

Position of the Condenser		Distance: ft (m)
Height between evaporator and condenser	Condenser placed higher than evaporator	Maximum: 98.4 (30)
	Condenser placed lower than evaporator	Maximum: -26.2 (-8)

5.2 Connecting Drainage Pipes

The water from the humidifier and the condensate water from the coil accumulate in the drain pan. The water in the drain pan is drained through the top or bottom of the unit.

5.2.1 Top Connection

A pipe has been pre-installed between the pump and the drainage copper pipe. The top end of the drainage copper pipe has been routed through the Condensate Pump outlet on the top plate. Connect the top end to your drainage system using a soft pipe.

5.2.2 Bottom Connection

To connect condensate drainage pipes from the bottom:

1. Open the rear door and remove filters. For details on removing filters, see [Figure 4.5 Remove Filters](#).
2. Unscrew the connector between the soft pipe and the drainage copper pipe. Route the soft pipe through the Condensate Pump outlet on the base plate to your drainage system.
3. A pipe has been pre-installed from the drain pan. Route the pipe through the Gravity Drain outlet on the base plate. Wrap a drain trap under the drain pan.

NOTE: All water drainage pipes should resist heat higher than 194 °F (90 °C).

NOTE: Ensure at least a 2% gradient towards the drain.

NOTE: There must be a drain trap placed at least 7.9 in. (200 mm) below the drain tray. Fill the drain trap with water.

5.3 Connecting Water Supply for Humidifier

NOTE: The connections must be sealed to prevent water leakage.

NOTE: The pressure of your water supply system should be within 14.5 psig to 101.5 psig (100 kPa to 700 kPa).

NOTE: The cylinder in the humidifier can be used for water with conductivity 350-1250 $\mu\text{S}/\text{cm}$. The water should not contain insoluble impurities that can be observed by eyes.

5.3.1 Top Connection

A soft pipe has been pre-installed between the humidifier and the humidifier supply copper pipe. The top end of the humidifier supply copper pipe is located on the top plate. If water is supplied from the top of the unit, connect the top end of the humidifier supply copper pipe (Humidifier Supply on top plate) to your water supply system.

5.3.2 Bottom Connection

If water is supplied to the humidifier from the bottom of the unit, open the front door, unscrew the connector between the soft pipe and the humidifier supply copper pipe, and route the soft pipe through the Humidifier Supply on the base plate to your water supply system.

NOTE: The end of the humidifier supply pipe is G 3/4 connector. You can use the convertor provided in the accessories bag to convert the connector to Rc1/2.

5.4 Connecting Gas Pipe and Liquid Pipe



WARNING! The operation of opening the valves and cutting the pipes at the bottom of the unit must be carried out as final operations.

Note the following while connecting gas pipe and liquid pipe:

- Connect the condenser and evaporator using copper pipes.
- Use as short refrigeration pipelines as possible to minimize the total charge of refrigerant and the pressure drops.
- Reduce the amount of bends to a minimum. The bend must be of large radius, at least equal to pipe diameter. If not using preformed curves, bend the pipes as follows:
 - a. Soft copper: by hand or bending device.
 - b. Hard copper: use preformed curves. Do not overheat the pipes when brazing so as to minimize oxidation.
- Lay the horizontal gas pipes with 1% downward gradient in the direction of the refrigerant flow.
- Maintain a minimum distance of 0.8 in. (20 mm) between the gas and liquid pipelines. If this is not possible, insulate both the lines.
- Insulate the piping to avoid damage to cable if the pipes are put next to electrical cables.
- Support both horizontal and vertical pipes with vibration damping clamps (including rubber gaskets). It is recommended to place clamps every 4.9 ft to 6.6 ft (1.5 m to 2 m)
- When the condenser is installed higher than the evaporator: install an inverted trap to the discharge line of the evaporator and the liquid line of the condenser. The inverted trap prevents the liquid refrigerant from flowing back when the condenser stops working. The top end of the inverted trap must be higher than the height of the copper pipes of the condenser. The minimum height difference is 5.9 in. (150 mm)
- Install an oil trap every 24.6 ft (7.5 m) of the vertical discharge line.

NOTE: Equivalent pipe length = Length of straight pipe + Equivalent length of bend

Table 5.2 External Diameter of Pipelines for CoolPhase Row CRD030 units.

Pipe Length ft (m)	CRD030 Gas Pipe in. (mm)	CRD030 Liquid Pipe in. (mm)
0 to 32.8 (0 to 10)	7/8 (22)	1/2 (12.7)
32.8 to 98.4 (10 to 30)	1, 1/8 (28)	5/8 (16)
98.4 to 262.4 (30 to 80)	1, 3/8 (35)	3/4 (19)
262.4 to 295.2 (80 to 90)	1, 5/8 (41)	7/8 (22)

NOTE: Suitable piping thickness must be used to support the pressure of the CoolPhase Row units.

Table 5.3 External Diameter of Pipelines for CoolPhase Row CRD040 units.

Pipe Length ft. (m)	CRD040 Gas Pipe in. (mm)	CRD040 Liquid Pipe in. (mm)
	External diameter mm (in.)	
0 to 32.8 (0 to 10)	7/8 (22)	1/2 (12.7)
32.8 to 65.6 (10 to 20)	1, 1/8 (28)	5/8 (16)
65.6 to 196.8 (20 to 60)	1, 3/8 (35)	3/4 (19)
196.8 to 295.2 (60 to 90)	1, 5/8 (41)	7/8 (22)

NOTE: Suitable piping thickness must be used to support the pressure of the CoolPhase Row units.

Table 5.4 Equivalent Length of Components

Liquid Pipe, External Diameter in. (mm)	Equivalent Length ft. (m)		
	90° Bend	45° Bend	T Type Three-Way
1/2 (12.7)	1.31 (0.4)	0.65 (0.2)	2.49 (0.76)
5/8 (16)	1.8 (0.55)	0.88 (0.27)	2.49 (0.76)
3/4 (19)	1.96 (0.6)	0.98 (0.3)	2.49 (0.76)
7/8 (22.2)	2.29 (0.7)	1.14 (0.35)	3.6 (1.1)
1-1/8 (28)	2.85 (0.87)	1.44 (0.44)	4.6 (1.4)
1-3/8 (35)	3.45 (1.05)	1.72 (0.53)	5.3 (1.6)
1-5/8 (41)	4.1 (1.25)	2.05 (0.625)	5.3 (1.6)

NOTE: Suitable piping thickness must be used to support the pressure of the CoolPhase Row units.

Installing Pipelines

1. Release the pre-charged nitrogen. The evaporator and condenser have been pre-charged with 29 psig (2 bar) nitrogen. Open all the Schrader valves in the system to release nitrogen.
2. Cut the liquid pipe and gas pipe connectors on the evaporator and condenser.
3. Lay the pipes between the evaporator and condenser.
4. Connect a nitrogen cylinder to the Schrader valve. Purge the pipe with nitrogen to flow through the pipe while welding the pipe.

NOTE: A pure dry nitrogen flow of 1 - 3 ft³/min (0.5 - 1.5 l/s) inside the pipe during brazing is sufficient to displace the air. Control the flow using a suitable measuring device.

NOTE: Nitrogen prevents the formation of copper oxide scale inside the piping. When copper is heated in the presence of air, copper oxide forms. Lubricating oil will dissolve these oxides from inside the copper pipes and deposit them throughout the system, clogging filter driers and affecting other system components.

NOTE: Before brazing connections, use wet rags to quench the heat and prevent damage to piping bushings or heat sensitive refrigerant components.

NOTE: When brazing connections from the bottom, do not weld the liquid pipe and the gas pipe at the same time. Weld one pipe and then another. The location of the liquid pipe and the gas pipe in the bottom is shown in the figure below.

Figure 5.6 Location of Liquid Pipe and Gas Pipe for Bottom Routing (CoolPhase Row CRD030)

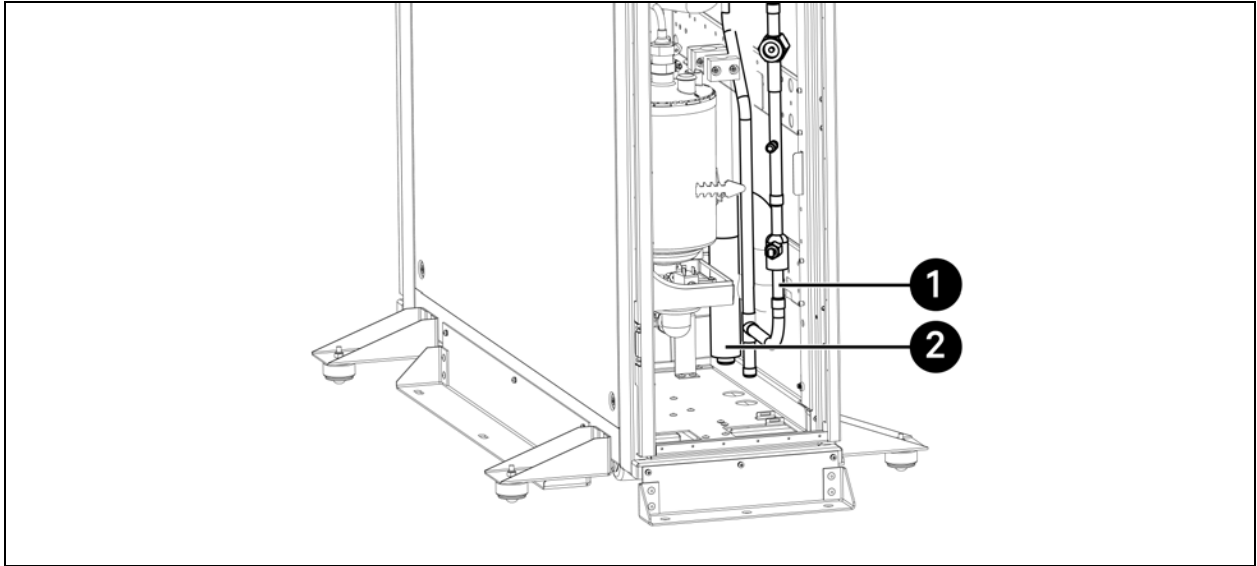

Item	Description
1	Liquid Pipe
2	Gas Pipe

Figure 5.7 Location of Liquid Pipe and Gas Pipe for Bottom Routing (CoolPhase Row CRD040)

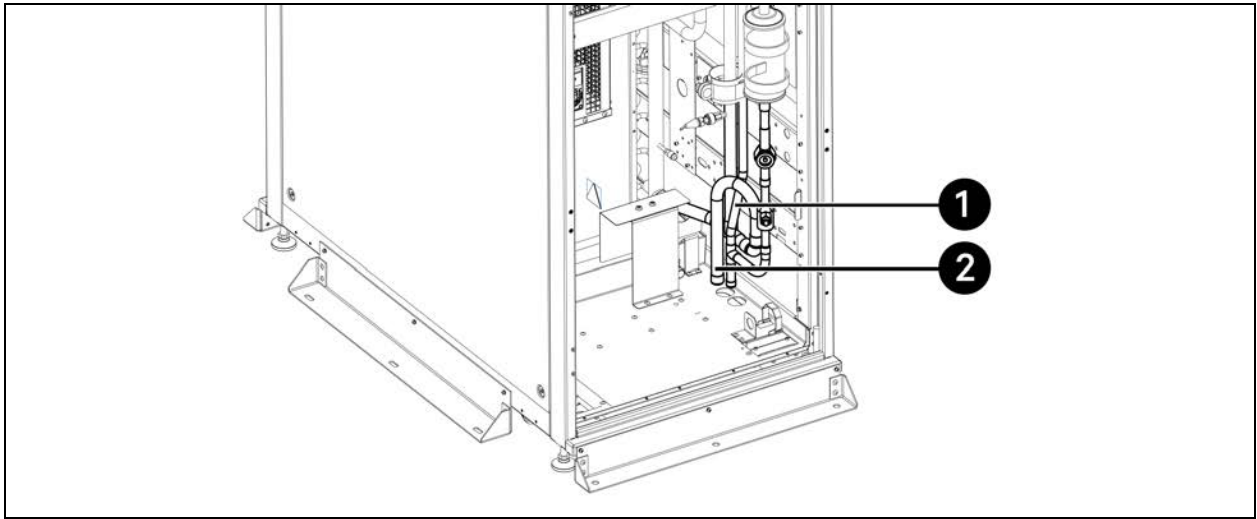

Item	Description
1	Liquid Pipe
2	Gas Pipe

6 Leak Detection System



WARNING! During the leak detection routine, the unit needs to be de-energized so the personnel can work safely to solve the leak of the gas.



WARNING! Under no circumstances shall potential sources of ignition be used in the searching for or detection of refrigerant leaks. A halide torch (or any other detector using a naked flame) shall not be used.

NOTE: It is recommended to conduct a design failure mode and effects analysis of the circulation airflow path, in the ITE AREA, to ensure the velocity is at least 3.2ft/s (1 m/s) for all operating conditions expected for the life of the ITE AREA.

NOTE: ITE AREA is a concept defined in UL/CSA Standard 60335-2-40 as an area of a building consisting of one or more rooms where the Information Technology Equipment, (ITE), is located, including support rooms served by the same special air-conditioning/air handling equipment as an ITE room.

Leak sensor readings will control the activation of the leak detection routine and command the closing of the Safety Shut Off Valve (SSOV).

6.1 Refrigerant Detection System



WARNING! Refrigerant sensors for refrigerant detection systems shall only be replaced with sensors specified by Vertiv™ and the installation needs to be performed by Vertiv™ personnel only.



CAUTION: Whenever main power is cycled at the unit the RLS latching relay needs to be manually reset.

Leak sensor readings will control the activation of the leak detection routine, as well as it will command the closing of the valve.

6.1.1 Leak Mitigation Action Steps

Step 1:

- Detect leak.
- Shut down compressor.
- Close the EEV valve.
- Safety Shut Off Valve (SSOV) closes.
- CoolPhase Row fans at full speed.
- CoolPhase Condensing Unit fans going to 100% , full speed.
- Alarms on the HMI to be displayed:
 - ■ Refrigerant leak exists.
 - ■ Refrigerant emergency routine
 - ■ Safety Shut Off Valve (SSOV) closed.

NOTE: These actions will remain until the unit is de-genericized for troubleshooting.

Step 2:

After the power cycle of the unit, the sensor will continue to send readings to the iCOM™ and if there is still detection of gas in the air, the Step 1 actions will repeat again.

If after the power cycle the sensor does not detect a leak, the iCOM™ will take the next actions for 5 minutes:

- Keep the compressor turned off.
- Keep the EEV closed.
- Turn on the CoolPhase Row fans to max speed.
- Alarms in the HMI will be shown:
 - Refrigerant emergency routine
- Reset for normal operation, pushing the safety relay button. Figure 6.2 for relay reset button location.

Step 3

After 5 minutes the fans will turn off.

The HMI will show the alarm indicating that the Safety Shut Off Valve is still closed, meaning that the system is waiting for the safety relay to be reset to restart normal operation.

6.1.2 Safety Shut Off Valve (SSOV)

The safety shut off valve is part of the leak detection routine. The leak sensor readings will control the activation of the leak detection routine, as well as it will command the closing of the valve. During the leak detection routine, the unit needs to be de-energized so the personnel can work safely to solve the leak of the gas.

According to UL 60335-2-40 22.133DV:

- Safety shut-off valves shall default to fully closed position when the appliance is de-energized for any reason other than failure of the supply mains.
- Safety shut-off valves that are activated by a leak detection system shall have manual operation for resetting that requires the aid of a tool.

Figure 6.1 Safety Shut Off Valve Location

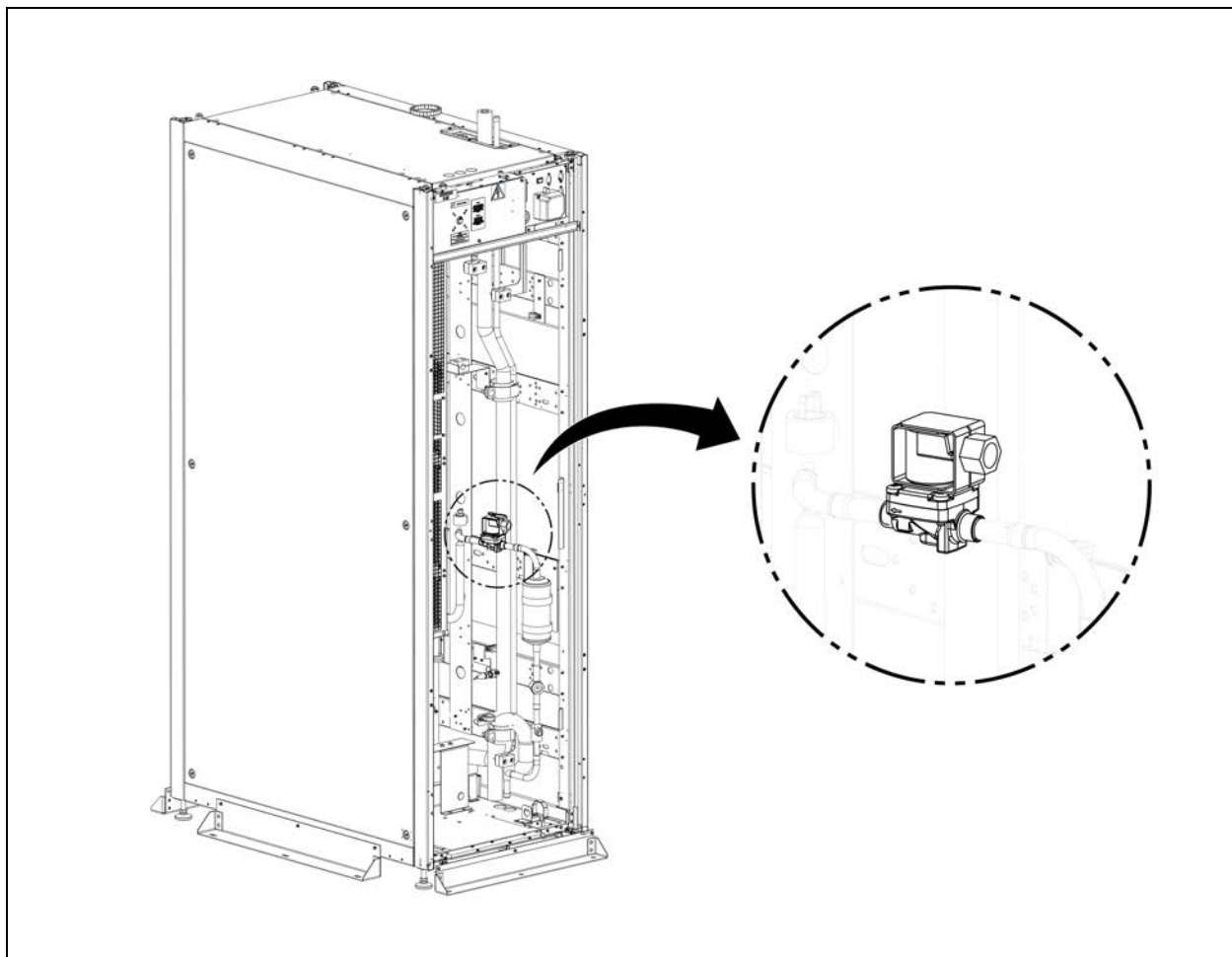

CAUTION: Whenever main power is cycled at the unit the RLS latching relay needs to be manually reset.

Figure 6.2 Relay Reset Button Location

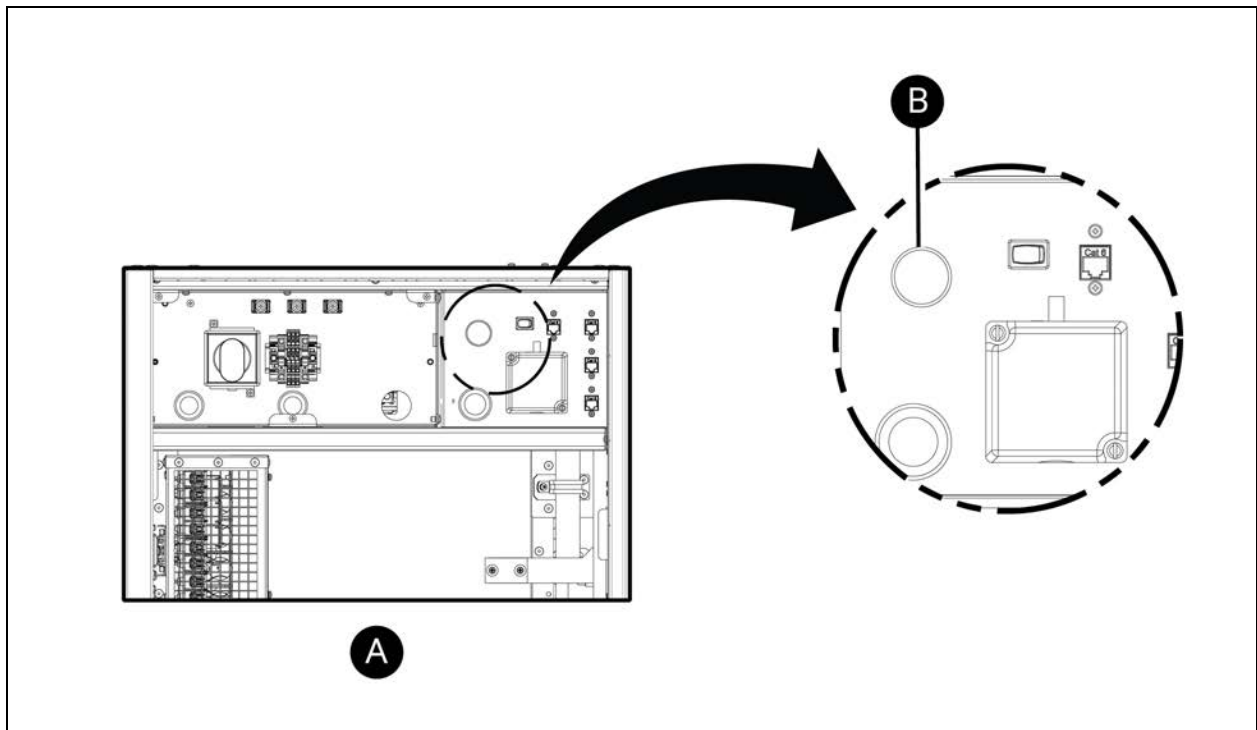

Item	Description
A	Rear side of the rack
B	Latching Relay Reset Button

7 Electrical Connections



WARNING! Arc flash and electric shock hazard. Open all local and remote electric power-supply disconnect switches, verify with a voltmeter that power is Off and wear appropriate, OSHA-approved personal protective equipment (PPE) per NFPA 70E before working within the electric control enclosure. Failure to comply can cause serious injury or death. Customer must provide earth ground to unit, per NEC, CEC and local codes, as applicable. Before proceeding with installation, read all instructions, verify that all the parts are included and check the nameplate to be sure the voltage matches available utility power. The Vertiv™ iCOM™ does not isolate power from the unit, even in the “Unit Off” mode. Some internal components require and receive power even during the “Unit Off” mode of the controller. The only way to ensure that there is NO voltage inside the unit is to install and open a remote disconnect switch. Refer to unit electrical schematic. Follow all local codes.



WARNING! Risk of electric shock. Can cause equipment damage, injury or death. Open all local and remote electric power supply disconnect switches and verify with a voltmeter that power is off before working within any electric connection enclosures. Service and maintenance work must be performed only by properly trained and qualified personnel and in accordance with applicable regulations and manufacturers’ specifications. Opening or removing the covers to any equipment may expose personnel to lethal voltages within the unit even when it is apparently not operating, and the input wiring is disconnected from the electrical source.

NOTE: The equipment shall be installed in accordance with national wiring regulation.

NOTE: A means for disconnection from the supply mains having a contact separation in all poles that provide full disconnection under overvoltage category III conditions must be incorporated in the fixed wiring.

Before proceeding with the electrical connections, ensure that:

- The unit has been fixed to the floor or the adjacent cabinets.
- All electrical components are in good condition.
- All terminal screws are tight.
- The supply voltage and frequency are as indicated on the unit.

NOTICE

Check cabling will not be subject to wear, corrosion, excessive pressure, vibration, sharp edges or any other adverse environmental effects. The check shall also consider the effects of aging or continual vibration from sources such as compressors or fans.

7.1 Connecting Power Supply Cables

The size of power cable must support the full load current of the installed unit. Do not fit the supply cable in the raceways inside the electrical panel. Use multipolar cables with sheath (CEI20-22) only.

Table 7.1 Rated Full Load Current (Unit Ampere) CRD0301 y CRD0401

Item	Model	CRD0301 (208/230V-Ph:3)			CRD0401 (208/230V-Ph:3)		
		Power Phase	L1	L2	L3	L1	L2
Indoor Unit	Control	1.25	1.25	-	1.25	1.25	-
	Fans Power Module	12	12	-	17.2	17.2	-
	Heaters	6.25	6.25	6.25	12.49	12.49	12.49
	Humidifier	6.25	6.25	6.25	6.25	6.25	6.25
	Condensate Pump	-	0.25	0.25	-	0.25	0.25
	Fans+Heaters	18.25	18.25	6.25	29.71	29.71	12.49
	Fans+Humidifier	18.25	18.25	6.25	23.47	23.47	6.25
	Fans + condensate pump	12	12.25	0.25	17.22	17.47	0.25

Table 7.2 Rated Full Load Current (Unit Ampere) CRD0300 y CRD0400

Item	Model	CRD0300 208/230V-Ph:1		CRD0400 208/230V-Ph:1		
		Power Phase	L1	L2	L1	L2
Indoor Unit	Control		1.25	1.25	1.25	1.25
	Fans Power Module		12	12	17.22	17.22
	Condensate Pump		0.25	0.25	0.25	0.25
	Fans + condensate pump		12.25	12.25	17.47	17.47

Table 7.3 Rated Full Load Current (Unit Ampere) CRD0304 y CRD0404

Item	Model	CRD0304 460V-Ph:3			CRD0404 460V-Ph:3		
		Power Phase	L1	L2	L3	L1	L2
Indoor Unit	Control	0.56	0.56	-	0.56	0.56	-
	Fans Power Module + Condensate Pump	12.25	12.25	-	17.47	17.47	-
	Heaters	2.82	2.82	2.82	5.65	5.65	5.65
	Humidifier	2.82	2.82	2.82	2.82	2.82	2.82
	Fans + Heaters	14.82	14.82	2.82	23.12	23.12	5.65
	Fans + Humidifier	14.82	14.82	2.82	20.29	20.29	2.82

NOTE: The heater and humidifier will not work at the same time.

NOTE: For condenser unit info, refer to the CoolPhase Condensing Unit User Manual.

To connect the power supply cables:

1. Open the rear door. The power box is located under the top panel. Remove the cover plate from the power box by removing three M4 x 10 pan head screws for both CoolPhase Row CRD030 and CRD040.
2. Route the power supply cables into the unit from the top or bottom panel and connect the cables to the L1, L2, L3 and PE terminals of power supply A on the main switch disconnecter.
3. If the unit will include dual power supply, route the power supply cables into the unit from the top or bottom panel and connect the cables to the L1, L2, L3 and PE terminals of power supply A and B on the main switch disconnecters.

NOTE: For the units that include dual power supply (ATS Circuit), with power supply 1 as the primary power feed and power supply 2 as secondary. When power supply 1 fails, power supply 2 automatically takes over. When power supply 1 restores, it automatically resumes its function as the primary power feed.

Table 7.4 Electrical Data—Air Cooled CRD030, 12 in. (300 mm) with Condensate Pump

Voltage	208-230 V/ 3 Ph/ 60 Hz	208-230 V/ 1 Ph/ 60 Hz	460 V/ 3 Ph/ 60 Hz
Reheat with Humidifier			
FLA	21	N/A	10.4
MCA	34.1	N/A	16.5
MOPD	40	N/A	15
Cooling Only			
FLA	N/A	13.8	7.1 *
MCA	N/A	17.3	8.8 *
MOPD	N/A	25	10 *
FLA = Full Load Amps; MCA = Minimum Circuit Ampacity; MOPD = Maximum Overcurrent Protection Device.			
* = This data is related to a ETO project.			

Table 7.5 Electrical Data—Air Cooled, CRD040, 24 in. (600 mm) with Condensate Pump

Voltage	208-230V/ 3 Ph/ 60Hz	208-230V/ 1 Ph/ 60Hz	460V/ 3 Ph/ 60Hz
Reheat with Humidifier			
FLA	33.2	N/A	15.7
MCA	49.4	N/A	23
MOPD	60	N/A	25
Cooling Only			
FLA	N/A	18.8	N/A
MCA	N/A	23.5	N/A
MOPD	N/A	40	N/A
FLA = Full Load Amps; MCA = Minimum Circuit Ampacity; MOPD = Maximum Overcurrent Protection Device.			

Figure 7.1 Connecting Power Supply Cables for 3-Phase CRD030 and CRD040

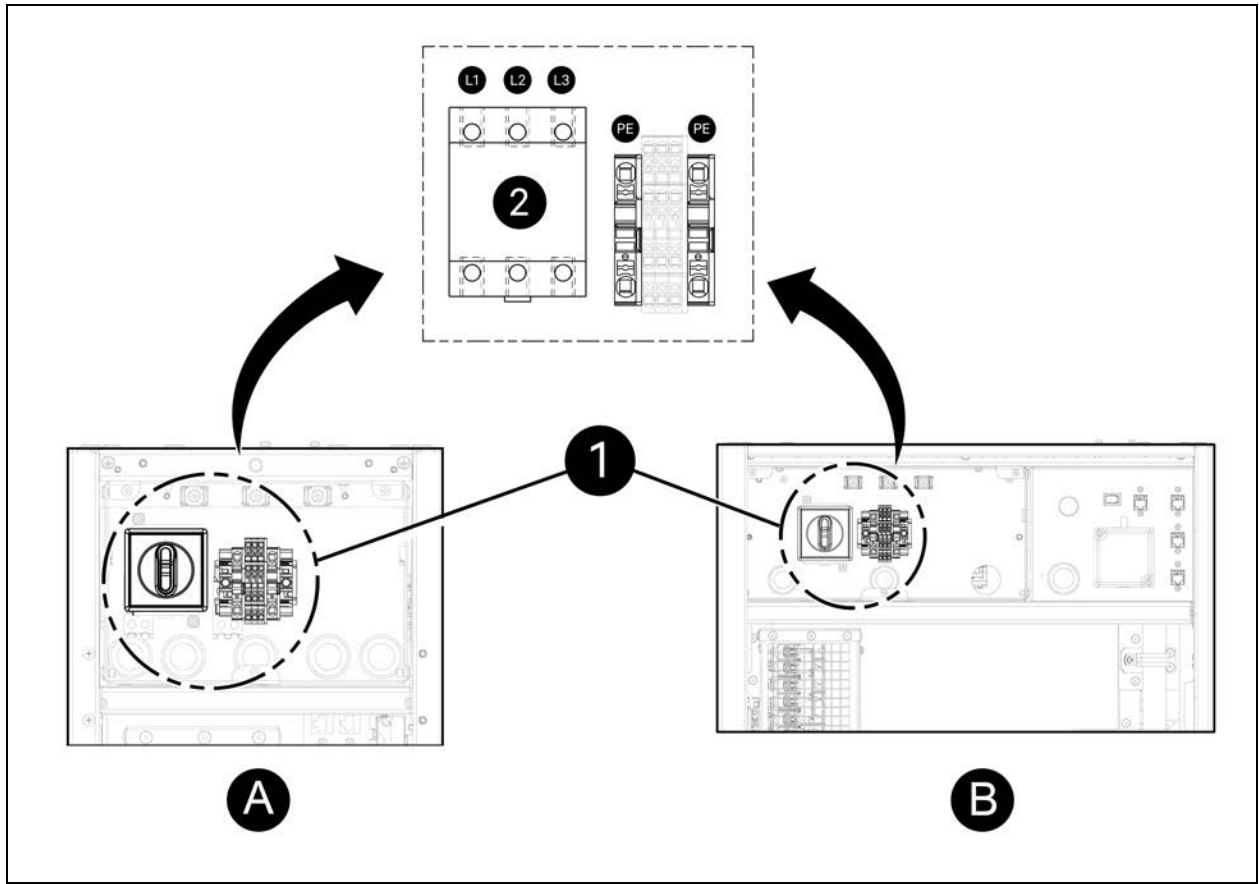

Item	Description	Item	Description
A	Power Box CRD030	2	Switch Disconnectors
B	Power Box CRD040	3	Connecting to power supply

Figure 7.2 Connecting Power Supply Cables for 1-Phase CRD030 and CRD040

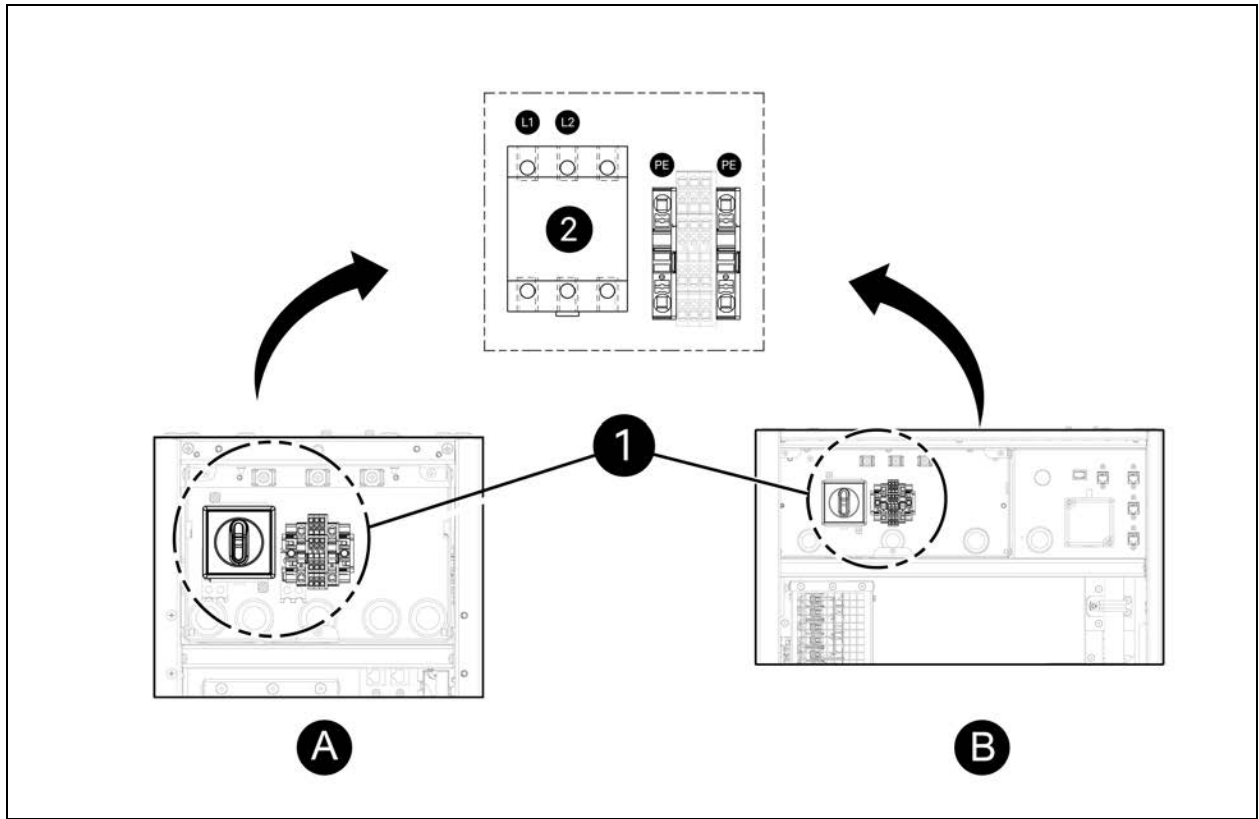

Item	Description	Item	Description
A	Power Box CRD030	1	Switch Disconnectors
B	Power Box CRD040	2	Connecting to power supply

7.2 Connecting Communications Cables

7.2.1 General Arrangement

NOTE: Take anti-static measures when connecting communications cables.

NOTE: The RJ45 port on the back of HMI is not available for any usage.

Figure 7.3 Terminal Block

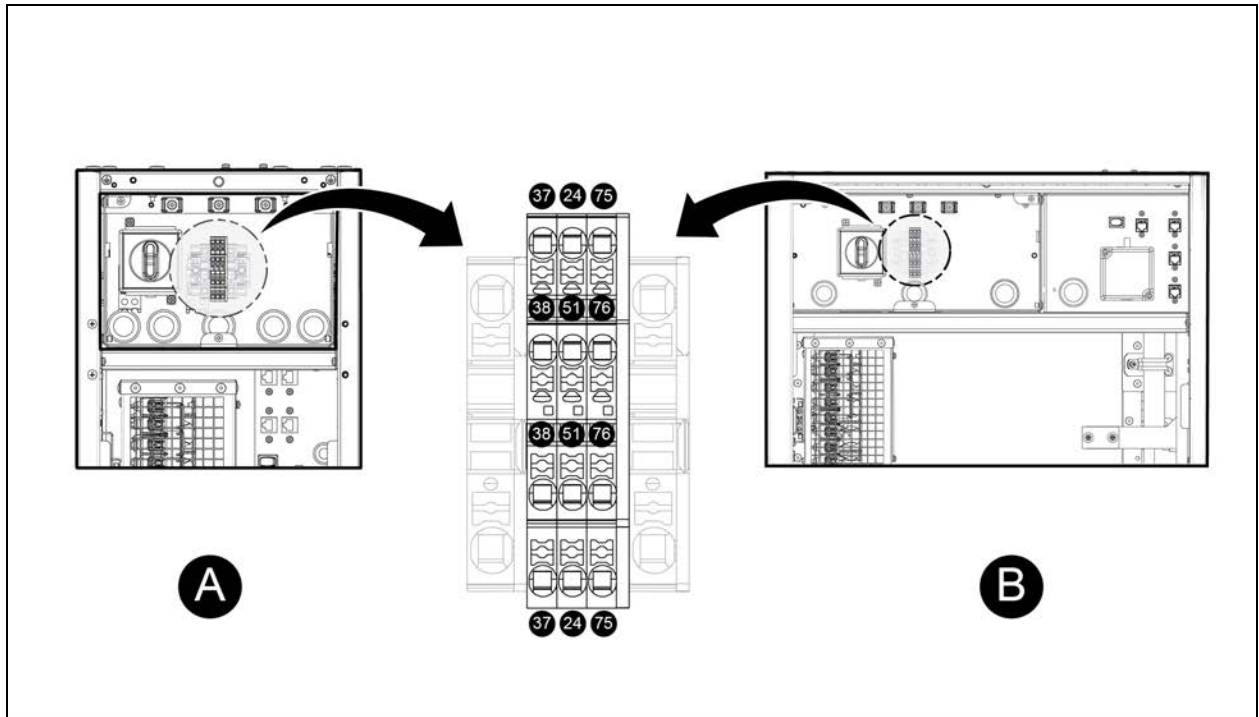

Item	Description	Item	Description
A	CoolPhase Row CRD030 evaporator	24/51	Water leakage sensor
B	CoolPhase Row CRD040 evaporator	75/76	Common alarm
37/38	Remote on/off device	-	-

Figure 7.4 Communications Ports

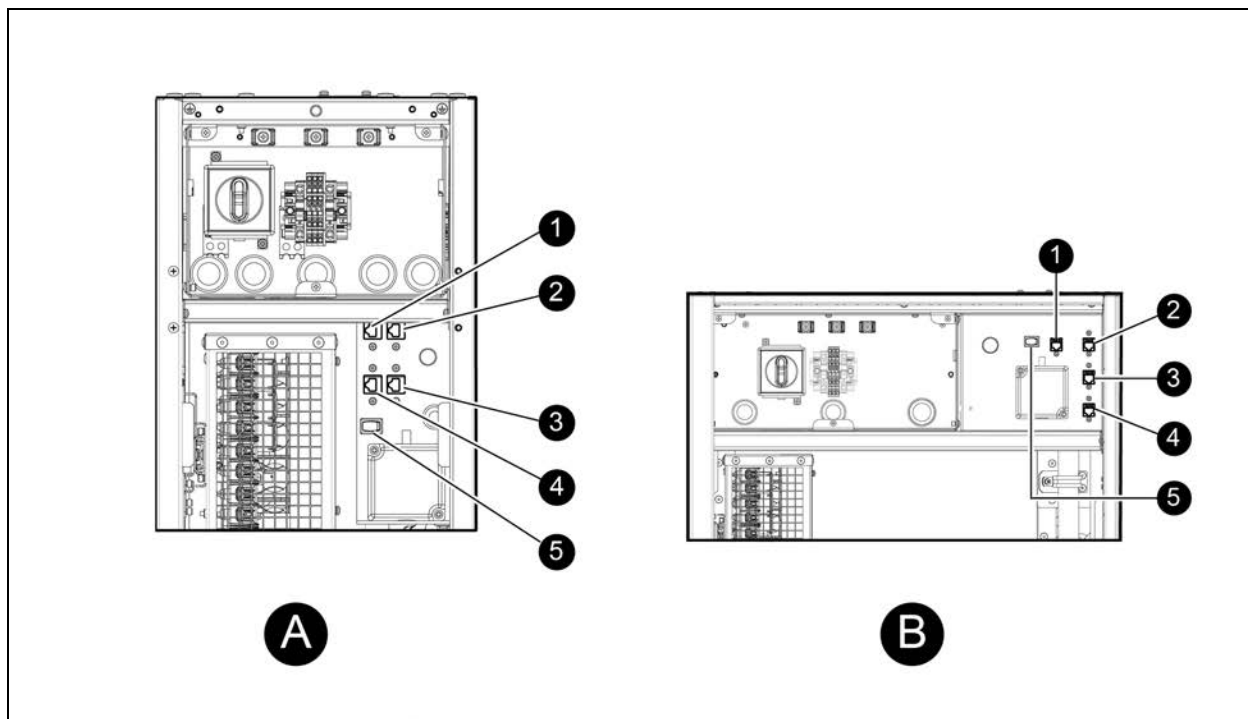

Item	Description	Item	Description
A	CoolPhase Row CRD030 evaporator	3	Z4- Outdoor Communication
B	CoolPhase Row CRD040 evaporator	4	Z2- Not used
1	Z1- Site and BMS Communication Connections	5	Humidifier Manual Drain Switch
2	Z3- Unit to Unit Networking (Teamwork)	-	-

7.2.2 Connecting Communications Cable between Evaporator and Condenser

The communications cable is not provided with the unit. To connect the communications cable, connect one end of the ethernet cable to the Z4 port of the evaporator, and connect the other end to terminals to the ethernet port located on the condenser E-box. The Vertiv™ iCOM™ board controls the operation of condenser fans through the communications cable.

NOTE: Use shielded cables as communication cables. The size of the cable should be larger than 0.75 mm², and the length should be shorter than 410 ft (125 m)

NOTE: Do not run the communication cable in the same conduit, raceway or chase used for power cable.

7.2.3 Connecting the Water Leakage Sensor (Optional)

The water leakage sensor is provided in the accessories bag. To connect the water leakage sensor, connect it to the 51 and 24 terminals.

7.2.4 Connecting Alarm Device (Optional)

The alarm device is not provided with the unit. To connect the alarm device, connect it to the 75 and 76 terminals on the terminal block, so that the Vertiv™ iCOM™ can send alarms to the alarm device.

7.2.5 Connecting Remote Temperature Sensors (Optional)

One remote temperature sensor is provided in the accessories bag. The unit can be connected with a maximum of 10 temperature sensors. It is recommended to place the sensors in front of the heat loads, 4.9 ft (1.5 m) higher than the unit base.

The remote sensor must be connected in series with the temperature and humidity sensor located on the E-box.

To connect remote temperature sensors:

1. Insert the connector of the sensor to the temperature and humidity sensor CAN port. Route the cable through the top or bottom of the unit. Connect the second sensor to the first sensor.
2. Fix the sensor on rack surface using the magnets provided in the kit. Do not fix it on an empty rack. Set the address on the dialing switch on the sensor, according to the following table.

Table 7.6 DIP Switch Settings for Wired Remote Sensor

2T sensor number/address	DIP-switch position								Factory Setting
	1	2	3	4	5	6	7	8	
Optional added sensors									
1	Off	Off	On	Off	On	Off	Off	Off	Unterminated
2	On	Off	On	Off	On	Off	Off	Off	Unterminated
3	Off	On	On	Off	On	Off	Off	Off	Unterminated
4	On	On	On	Off	On	Off	Off	Off	Unterminated
5	Off	Off	Off	On	On	Off	Off	Off	Unterminated
6	On	Off	Off	On	On	Off	Off	Off	Unterminated
7	Off	On	Off	On	On	Off	Off	Off	Unterminated
8	On	On	Off	On	On	Off	Off	Off	Unterminated
9	Off	Off	On	On	On	Off	Off	Off	Unterminated
10	On	Off	On	On	On	Off	Off	Off	Unterminated
The last 2T sensor in the array must be terminated.									

NOTE: Up is on, down is off on the DIP switch.

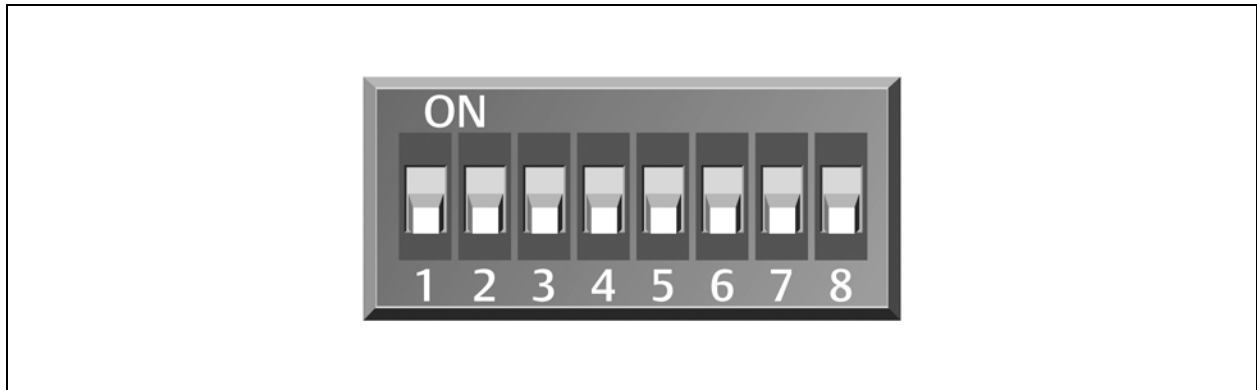
Figure 7.5 DIP Switches in 2T Sensor.

7.2.6 Connecting the Remote On/Off Device (Optional)

The remote on/off device is not provided with the unit. To connect the remote on/off device, connect it to the 37 and 38 terminals on the terminal block. These two terminals have been connected with a jumper in factory, and you need to remove this jumper before connecting to the remote on/off device.

NOTE: If the jumper between the 37 and 38 terminals is removed but no remote on/off device is connected to the terminals, the unit cannot be powered on.

7.2.7 Connecting for Teamwork

For more instructions, refer to submittal drawings Electrical Field Connections. See [Submittals](#).

7.3 Electrical Installation Checklist

After the system electrical installation is completed, the following requirements should be met.

Table 7.7 Electrical Inspection Checklist

Particulars	Results
The system electrical loop has no open-circuit or short-circuit existing in the electrical connection.	
The power supply voltage meets the rated voltage on the nameplate of the unit.	
Verify Power wires sizing matches the recommended gauge for the unit that is being installed.	
Power and grounding cables are connected to the switch disconnect(s) and PE terminal block(s) in the indoor unit correctly as per the norms.	
The ratings of the fuses are correct.	
The control cables are configured and subsequently, fixed properly.	
All the cables and connector connections, including the fixing blocks, are firmly and appropriately fixed.	

NOTE: After confirming the preceding points, user can replace the electrical plate and begin the start-up inspection & functional testing.

8 Start-Up

8.1 Charging Refrigerant and Lubricating Oil



WARNING! Ensure that contamination of different refrigerants does not occur when using charging equipment. Hoses or lines shall be as short as possible to minimize the amount of refrigerant contained in them.



WARNING! Ensure that the area is in the open or that it is adequately ventilated before breaking into the system or conducting any hot work. A degree of ventilation shall continue during the period that the work is carried out. The ventilation should safely disperse any released refrigerant and preferably expel it externally into the atmosphere.



WARNING! Ensure that the refrigerating system is earthed prior to charging the system with refrigerant.



WARNING! Extreme care shall be taken not to overfill the refrigerating system.

NOTICE:

Cylinders shall be kept in an appropriate position according to the instructions.

NOTICE:

Prior to recharging the system, it shall be pressure-tested with the appropriate purging gas. The system shall be leak-tested on completion of charging but prior to commissioning. A follow up leak test shall be carried out prior to leaving the site.

NOTICE:

Label the system when charging is complete (if not already).

8.1.1 Amount of Refrigerant and Lubricating Oil

The following checks shall be applied to installations using flammable refrigerants:

- The actual refrigerant charge is in accordance with the room size within which the refrigerant containing parts are installed.
- The ventilation machinery and outlets are operating adequately and are not obstructed.
- If an indirect refrigerating circuit is being used, the secondary circuit shall be checked for the presence of refrigerant.
- Marking to the equipment continues to be visible and legible. Markings and signs that are illegible shall be corrected.
- Refrigerating pipe or components are installed in a position where they are unlikely to be exposed to any substance which may corrode refrigerant containing components, unless the components are constructed of materials which are inherently resistant to being corroded or are suitably protected against being so corroded.



CAUTION: Do not use refrigerant and lubricating oil of poor quality or wrong type, as they can damage the system.

NOTE: The unit is not charged with refrigerant from factory. You need to charge refrigerant on site. The refrigerant for the unit is R-32.

NOTE: The unit has been charged with certain amount of lubricating oil in the factory. If the liquid pipe between the evaporator and condenser is shorter than 52.5 ft (16 m) and the unit is not equipped with a low ambient version you do not need to add extra lubricating oil. If the unit is equipped with a low ambient kit or if the liquid pipe between the evaporator and condenser is longer than 52.5 ft (16 m)

NOTE: , you need to add extra lubricating oil. The lubricating oil for the unit is PVE (FW68S).

Table 8.1 Total Refrigerant Charge CoolPhase Row CRD030 Standard

Total Refrigerant Charge for CRD030					
Liquid pipe length ft (m)	Liquid Line Diameter in. (mm)	Suction Line Diameter in. (mm)	Total refrigerant charge lb (kg)	Extra lubricating oil charge fl oz (ml)	Effective Dispersal Volume ft3 (m3)
16.4 (5)	1/2 (12.7)	7/8 (22.2)	10.70 (4.8)	0	1,116.9 (31.6)
32.8 (10)	1/2 (12.7)	7/8 (22.2)	11.92 (5.4)	0	1,244.6 (35.2)
49.2 (15)	5/8 (15.8)	1 1/8 (28.5)	15.26 (6.9)	0	1,593.1 (45.1)
65.6 (20)	5/8 (15.8)	1 1/8 (28.5)	17.19 (7.8)	0	1,794.4 (50.8)
82 (25)	5/8 (15.8)	1 1/8 (28.5)	19.12 (8.6)	0	1,995.8 (56.5)
98.4 (30)	5/8 (15.8)	1 1/8 (28.5)	21.06 (9.5)	8.4 (249.1)	2,197.1 (62.2)
114.8 (35)	3/4 (19)	1 3/8 (34.9)	29.75 (13.5)	11.9 (352.2)	3,106.7 (87.9)
131.2 (40)	3/4 (19)	1 3/8 (34.9)	32.67 (14.8)	13.1 (386.5)	3,409 (96.5)
147.6 (45)	3/4 (19)	1 3/8 (34.9)	35.55 (16.1)	14.2 (420.7)	3,711.6 (105.1)
164 (50)	3/4 (19)	1 3/8 (34.9)	38.44 (17.4)	15.4 (455.0)	4,014.1 (113.6)
180.4 (55)	3/4 (19)	1 3/8 (34.9)	41.32 (18.7)	16.5 (489.3)	4,316.6 (122.2)
196.8 (60)	3/4 (19)	1 3/8 (34.9)	44.21 (20)	17.7 (523.6)	4,619.2 (130.8)
213.2 (65)	3/4 (19)	1 3/8 (34.9)	47.09 (21.3)	18.9 (557.9)	4,921.5 (139.3)
229.6 (70)	3/4 (19)	1 3/8 (34.9)	49.98 (22.7)	20.0 (592.2)	5,224 (147.9)
246 (75)	3/4 (19)	1 3/8 (34.9)	52.86 (24)	21.2 (626.5)	5,526.5 (156.5)
262.4 (80)	3/4 (19)	1 3/8 (34.9)	55.75 (25.3)	22.3 (660.8)	5,829.1 (165)
278.8 (85)	7/8 (22.2)	1 5/8 (41.2)	75.70 (34.3)	30.3 (895.4)	7,898.5 (223.6)
295.2 (90)	7/8 (22.2)	1 5/8 (41.2)	79.58 (36)	31.8 (941.4)	8,304.8 (235.1)

NOTE: If the lengths, diameters, and charges are intermediate to those shown in the table, the next higher values should be taken.



WARNING! When a refrigerant leak occurs the minimum airflow with an air velocity of 1 (m/s) for the CoolPhase Row CRD030 Low Ambient Version is 3,507 CFM (5,956 m³/h)

Table 8.2 Total Refrigerant Charge CoolPhase Row CRD030 Low Ambient Version

Total Refrigerant Charge for CRD030 Low Ambient Version					
Liquid pipe length ft (m)	Liquid Line Diameter in (mm)	Suction Line Diameter in (mm)	Total refrigerant charge lb (kg)	Extra lubricating oil charge fl oz (ml)	Effective Dispersal Volume ft ³ (m ³)
16.4 (5)	1/2 (12.7)	7/8 (22.2)	21.7 (9.8)	8.7 (257.0)	2,267.2 (64.2)
32.8 (10)	1/2 (12.7)	7/8 (22.2)	22.9 (10.4)	9.2 (271.5)	2,394.9 (67.8)
49.2 (15)	5/8 (15.8)	1 1/8 (28.5)	26.2 (11.9)	10.5 (311.0)	2,743.5 (77.6)
65.6 (20)	5/8 (15.8)	1 1/8 (28.5)	28.2 (12.8)	11.3 (333.8)	2,944.8 (83.3)
82 (25)	5/8 (15.8)	1 1/8 (28.5)	30.1 (13.6)	12.1 (356.6)	3,146.1 (89)
98.4 (30)	5/8 (15.8)	1 1/8 (28.5)	32 (14.5)	12.8 (379.5)	3,347.4 (94.7)
114.8 (35)	3/4 (19)	1 3/8 (34.9)	40.7 (18.5)	16.3 (482.6)	4,257 (120.5)
131.2 (40)	3/4 (19)	1 3/8 (34.9)	43.6 (19.8)	17.5 (516.9)	4,559.3 (129.1)
147.6 (45)	3/4 (19)	1 3/8 (34.9)	46.5 (21.1)	18.6 (551.1)	4,861.9 (137.6)
164 (50)	3/4 (19)	1 3/8 (34.9)	49.4 (22.4)	19.8 (585.4)	5,164.4 (146.2)
180.4 (55)	3/4 (19)	1 3/8 (34.9)	52.3 (23.7)	21.0 (619.7)	5,466.9 (154.8)
196.8 (60)	3/4 (19)	1 3/8 (34.9)	55.2 (25)	22.1 (654.0)	5,769.5 (163.3)
213.2 (65)	3/4 (19)	1 3/8 (34.9)	58.1 (26.3)	23.3 (688.3)	6,071.8 (171.9)
229.6 (70)	3/4 (19)	1 3/8 (34.9)	61 (27.7)	24.4 (722.6)	6,374.3 (180.5)
246 (75)	3/4 (19)	1 3/8 (34.9)	63.9 (29)	25.6 (756.9)	6,676.8 (189)
262.4 (80)	3/4 (19)	1 3/8 (34.9)	66.8 (30.3)	26.8 (791.2)	6,979.4 (197.6)
278.8 (85)	7/8 (22.2)	1 5/8 (41.2)	86.7 (39.3)	34.7 (1,025.8)	9,048.8 (256.2)
295.2 (90)	7/8 (22.2)	1 5/8 (41.2)	90.5 (41)	36.2 (1,071.8)	9,455.1 (267.7)

NOTE: If the lengths, diameters, and charges are intermediate to those shown in the table, the next higher values should be taken.

Table 8.3 Total Refrigerant Charge for CoolPhase Row CRD040 Standard

Total Refrigerant Charge for CRD040					
Liquid pipe length ft (m)	Liquid Line Diameter in (mm)	Suction Line Diameter in (mm)	Total refrigerant charge lb (kg)	Extra lubricating oil charge fl oz (ml)	Effective Dispersal Volume ft ³ (m ³)
16.4 (5)	1/2 (12.7)	7/8 (22.2)	11.8 (5.3)	0	1,232 (34.9)
32.8 (10)	5/8 (15.8)	1 1/8 (28.5)	14.3 (6.5)	0	1,506.9 (42.7)
49.2 (15)	5/8 (15.8)	1 1/8 (28.5)	16.4 (7.4)	0	1,708.2 (48.4)
65.6 (20)	5/8 (15.8)	1 1/8 (28.5)	18.3 (8.3)	0	1,909.5 (54.1)

Table 8.3 Total Refrigerant Charge for CoolPhase Row CRD040 Standard (continued)

Total Refrigerant Charge for CRD040					
Liquid pipe length ft (m)	Liquid Line Diameter in (mm)	Suction Line Diameter in (mm)	Total refrigerant charge lb (kg)	Extra lubricating oil charge fl oz (ml)	Effective Dispersal Volume ft3 (m3)
82 (25)	3/4 (19)	1 3/8 (34.9)	25.1 (11.4)	10.0 (296.6)	2,616.7 (74.1)
98.4 (30)	3/4 (19)	1 3/8 (34.9)	27.9 (12.7)	11.2 (330.9)	2,919.3 (82.7)
114.8 (35)	3/4 (19)	1 3/8 (34.9)	30.9 (14.0)	12.3 (365.2)	3,221.8 (91.2)
131.2 (40)	3/4 (19)	1 3/8 (34.9)	33.8 (15.3)	13.5 (399.5)	3,524.1 (99.8)
147.6 (45)	3/4 (19)	1 3/8 (34.9)	36.7 (16.6)	14.7 (433.8)	3,826.6 (108.4)
164 (50)	3/4 (19)	1 3/8 (34.9)	39.5 (17.9)	15.8 (468.1)	4,129.2 (116.9)
180.4 (55)	3/4 (19)	1 3/8 (34.9)	42.5 (19.3)	17.0 (502.4)	4,431.7 (125.5)
196.8 (60)	7/8 (22.23)	1 5/8 (41.2)	57.3 (26.0)	22.9 (678.0)	5,981.4 (169.4)
213.2 (65)	7/8 (22.23)	1 5/8 (41.2)	61.2 (27.8)	24.5 (724.1)	6,387.9 (180.9)
229.6 (70)	7/8 (22.23)	1 5/8 (41.2)	65.1 (29.5)	26.0 (770.2)	6,794.2 (192.4)
246 (75)	7/8 (22.23)	1 5/8 (41.2)	69 (31.3)	27.6 (816.3)	7,200.7 (203.9)
262.4 (80)	7/8 (22.23)	1 5/8 (41.2)	72.9 (33.1)	29.2 (862.3)	7,607.0 (215.4)
278.8 (85)	7/8 (22.23)	1 5/8 (41.2)	76.8 (34.8)	30.7 (908.4)	8,013.6 (226.9)
295.2 (90)	7/8 (22.23)	1 5/8 (41.2)	80.7 (36.6)	32.3 (954.5)	8,419.9 (238.4)

NOTE: If the lengths, diameters, and charges are intermediate to those shown in the table, the next higher values should be taken.



WARNING! When a refrigerant leak occurs the minimum airflow with an air velocity of 1 (m/s) for the CoolPhase Row CRD040 Low Ambient Version is 3,674 CFM (6,242 m3/h).

Table 8.4 Total Refrigerant Charge for CoolPhase Row CRD040 Low Ambient Version

Total Refrigerant Charge for CRD040 Low Ambient Version					
Liquid pipe length ft (m)	Liquid Line Diameter in (mm)	Suction Line Diameter in (mm)	Total refrigerant charge lb (kg)	Extra lubricating oil charge fl oz (ml)	Effective Dispersal Volume ft3 (m3)
16.4 (5)	1/2 (12.7)	7/8 (22.23)	30.5 (13.8)	12.2 (361.3)	3,187.5 (90.3)
32.8 (10)	5/8 (15.8)	1 1/8 (28.5)	33.2 (15.1)	13.3 (392.5)	3,462.4 (98.0)
49.2 (15)	5/8 (15.8)	1 1/8 (28.5)	35.1 (15.9)	14.0 (415.3)	3,663.8 (103.8)
65.6 (20)	5/8 (15.8)	1 1/8 (28.5)	37.0 (16.8)	14.8 (438.1)	3,865.1 (109.5)
82 (25)	3/4 (19)	1 3/8 (34.9)	43.8 (19.9)	17.5 (518.3)	4,572.3 (129.5)
98.4 (30)	3/4 (19)	1 3/8 (34.9)	46.7 (21.2)	18.7 (552.6)	4,874.8 (138.0)
114.8 (35)	3/4 (19)	1 3/8 (34.9)	49.6 (22.5)	19.8 (586.9)	5,177.3 (146.6)
131.2 (40)	3/4 (19)	1 3/8 (34.9)	52.5 (23.8)	21.0 (621.2)	5,479.6 (155.2)

Table 8.4 Total Refrigerant Charge for CoolPhase Row CRD040 Low Ambient Version (continued)

Total Refrigerant Charge for CRD040 Low Ambient Version					
Liquid pipe length ft (m)	Liquid Line Diameter in (mm)	Suction Line Diameter in (mm)	Total refrigerant charge lb (kg)	Extra lubricating oil charge fl oz (ml)	Effective Dispersal Volume ft ³ (m ³)
147.6 (45)	3/4 (19)	1 3/8 (34.9)	55.4 (25.1)	22.2 (655.5)	5,782.2 (163.7)
164 (50)	3/4 (19)	1 3/8 (34.9)	58.3 (26.4)	23.3 (689.7)	6,084.7 (172.3)
180.4 (55)	3/4 (19)	1 3/8 (34.9)	61.2 (27.8)	24.5 (724.0)	6,387.2 (180.9)
196.8 (60)	7/8 (22.23)	1 5/8 (41.2)	76.0 (34.5)	30.4 (899.7)	7,936.9 (224.8)
213.2 (65)	7/8 (22.23)	1 5/8 (41.2)	79.9 (36.3)	32.0 (945.8)	8,343.5 (236.3)
229.6 (70)	7/8 (22.23)	1 5/8 (41.2)	83.8 (38.0)	33.5 (991.9)	8,749.8 (247.8)
246 (75)	7/8 (22.23)	1 5/8 (41.2)	87.7 (39.8)	35.1 (1,037.9)	9,156.3 (259.3)
262.4 (80)	7/8 (22.23)	1 5/8 (41.2)	91.6 (41.6)	36.7 (1,084.0)	9,562.6 (270.8)
278.8 (85)	7/8 (22.23)	1 5/8 (41.2)	95.5 (43.3)	38.2 (1,130.1)	9,969.1 (282.3)
295.2 (90)	7/8 (22.23)	1 5/8 (41.2)	99.4 (45.1)	39.8 (1,176.1)	10,375.4 (293.8)

NOTE: If the lengths, diameters, and charges are intermediate to those shown in the table, the next higher values should be taken.

8.2 Start-Up Procedure

8.2.1 First Start-up (or After Long Standstill)

NOTE: Vacuum and refrigerant charge already done up to this point.

Start the unit as follows:

1. Open all valves in the system according to the instruction labels attached to the valves.
2. Using a suitable detector verify that there are no refrigerant leaks. If there are any, then repair the leak and recharge the refrigerant.
3. At least 4 hours before start-up, close the main switch and the circuit breaker for transformer protection on the electrical panel. The HMI will turn on immediately to indicate the presence of electrical power. If the screen does not light up, check the main power supply.
4. Check that there are no water leaks.
5. Disconnect all disconnecter switches.
6. Check if the supply voltage is normal. If so, switch on all the disconnecter switches.
7. Ensure that the compressor in the condensing unit has been preheated for at least 4 hours before starting the unit.
8. Start the unit by pressing and holding the ON/OFF button on the HMI display for three seconds.
9. Ensure that all control system settings (temperature and humidity setpoints) are correct and that there are no alarms.
10. Once the system is operating under load, carry out the following checks:
 - Verify that the fans are operating properly.

- Ensure that the temperature and relative humidity are reached, and that the humidifier and heaters operate when required.
- Ensure that the compressor in the condensing unit operates when required.
- Ensure that the fan speed controller on the external condenser is calibrated correctly, and that it controls the fan operation.
- Ensure that all the sensors have been calibrated.

Restart

After a power interruption, the unit must be manually restarted by activating the latching relay once power is restored. Refer to [Latching Relay Button Release Location](#).

8.3 Humidifier

For further instructions related to the humidifier on this product, please refer to User Manual from [Carel OEM Kit](#)

This page intentionally left blank

9 Controls Instructions

For more information on operating instructions, interface, communication, control and monitoring of the units, refer to the [iCOM User Manual](#).

This page intentionally left blank

10 Maintenance



WARNING! All maintenance operations must be carried out strictly observing the National accident prevention regulations, especially the accident prevention regulations concerning electrical systems, refrigerators and manufacturing resources. Maintenance may be done to air conditioning equipment only by authorized and qualified technicians. To keep all warranties valid, the maintenance must adhere to the manufacturer's instructions.



WARNING! The work should be done on the system only when it is at switched-off. Stop the system by switching off the air conditioner at the Vertiv™ iCOM™ and the main switch. Check that the electrical components of device are off and not receiving a power supply.



WARNING! If the unit remains off for more than 8 hours for service, the refrigerant must be evacuated from the system.

NOTICE

Intrinsically safe components and electrical components that are sealed must be replaced. Repair should not be attempted.

NOTICE

Only original spare parts made by Vertiv™ may be used. Using third-party material can invalidate the warranty. When the spare parts must be brazed, be careful not to damage the internal parts (gaskets, seals, o-rings, etc.).

NOTICE

Risk of release of hazardous substances into the environment. Can cause environmental pollution and violation of environmental regulations.

Repair and maintenance to electrical components shall include initial safety checks and component inspection procedures. If a fault exists that could compromise safety, then no electrical supply shall be connected to the circuit until it is satisfactorily dealt with. If the fault cannot be corrected immediately but it is necessary to continue operation, an adequate temporary solution shall be used. This shall be reported to the owner of the equipment, so all parties are advised.

Initial safety checks shall include:

- That capacitors are discharged: this shall be done in a safe manner to avoid possibility of sparking.
- No live electrical components and wiring are exposed while charging, recovering or purging the system.
- That there is continuity of earth bonding.

10.1 Maintenance Schedule

Conduct monthly, quarterly, biannual and annual checks according to the following guidelines.

Table 10.1 Maintenance Schedule

Component	Check Items	Maintenance Period			
		Monthly by user	3 months	6 months	1 year
General	Check unit/remote display for clogged-filter warning	x			
	Check for irregular noise from unit fans	x			
	Check for irregular noise from compressor	x			
	Check for irregular noise from remote condenser fans (if applicable)	x			
Filters	Check the state of filters		x		
	Clean or replace air filters if necessary		x		
Fan	Verify that impellers move freely		x		
	Check bearings			x	
	Check that motor supports are fixed securely			x	
Electronics	Check the condition of contactors			x	
	Check electrical connections				x
	Check the operation of Vertiv™ iCOM™			x	
	Check unit operation sequence			x	
Humidifier	Check steam hoses conditions			x	
	Check cylinder conditions				x
Refrigerant Circuit	Check compressor noise or vibrations		x		
	Check sight glass for problems		x		
	Check main refrigerant circuit pressure		x		
	Check compressor suction superheat		x		
	Check discharge temperature		x		

10.2 Air Filters

Check the air filters monthly to maintain efficient air distribution through the evaporator coil.

To replace filters:

1. Open the rear door and disconnect the main circuit breaker.
2. If the filters appear dirty, remove them. For details on removing filters, see topic [4.5 Remove Filters](#).

NOTE: After cleaning or replacing the filter and before reassembling the unit, check that the air differential pressure switch tubes are correctly installed.

10.3 Fan



WARNING! Risk of electric shock and contact with high-speed rotating fans. Can cause injury or death. Switch off all local and remote electrical supplies, verify that power is off with a voltmeter and verify that all fans have stopped rotating before working inside the unit cabinet or disconnecting the fan power wires.

To replace the fan:

1. Open the rear door and disconnect the main circuit breaker.
2. Turn off the unit (switch disconnecter)
3. Open the front door.
4. Remove the fan frame assembly by removing the four M4 x 10 pan screws in the corners.
5. Set the fan assembly in a work area.
6. Remove the fan by removing the four M4 x 80 pan head screws, remove one grounding screw that attach the fan to the fan frame, and unplug the power supply terminal from the power socket on the fan frame assembly.
7. Reverse the steps to install the replacement fan.

Figure 10.1 Removing fan.

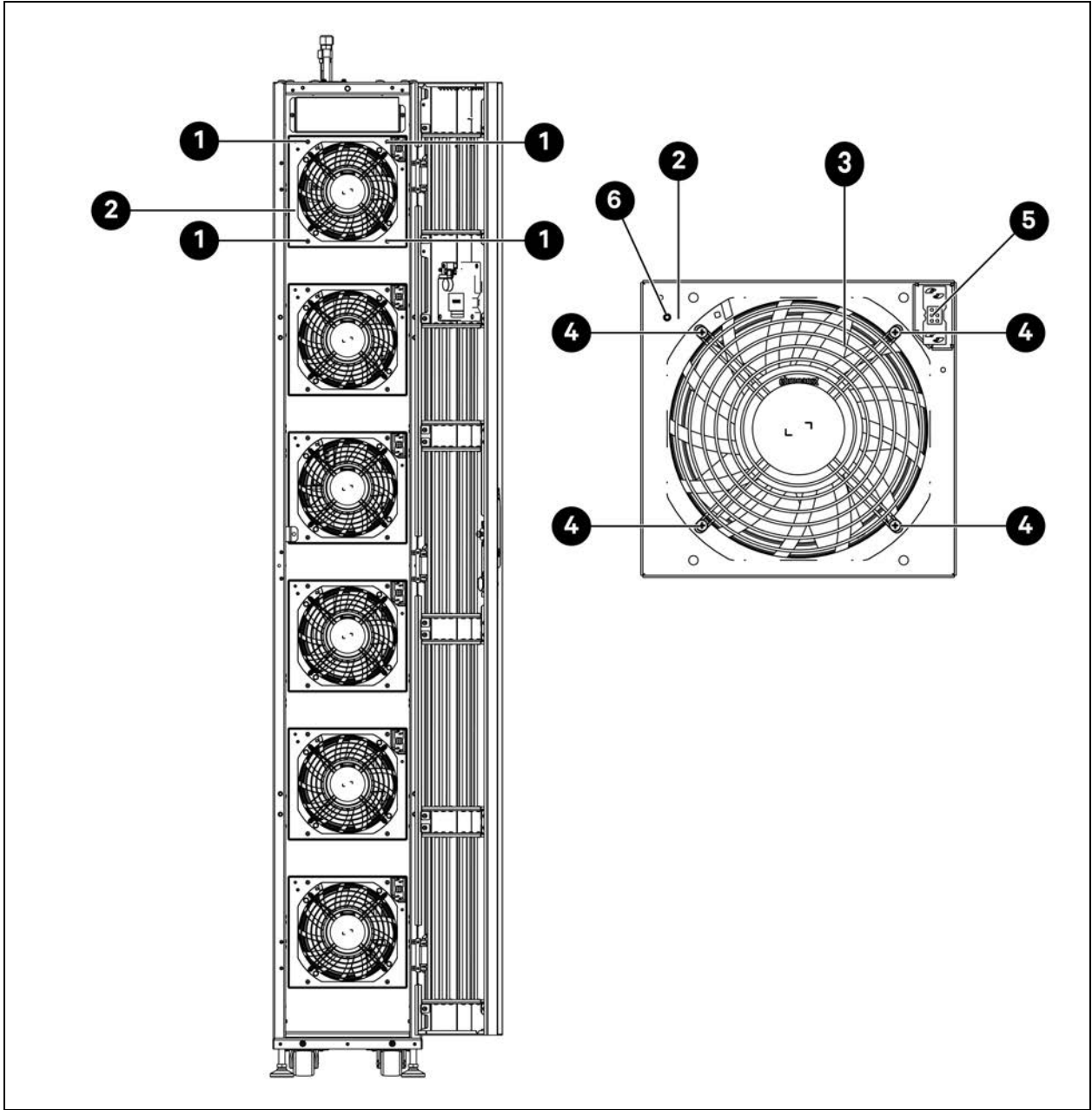

Item	Description	Item	Description
1	M4 x 10 pan screw	4	M4 x 80 Pan head screw
2	Fan frame assembly	5	Power Socket
3	Fan	6	Grounding screw

10.4 Humidifier



CAUTION: Hot surface. The cylinder may be hot. Let it cool down before touching it or use protective gloves.



CAUTION: The humidifier and its cylinder contain live electrical components; therefore all service and/or maintenance operations must be performed by expert and qualified personnel.

For further instructions related to the humidifier, please refer to User Manual from [Carel Kit OEM Humidifier User Manual](#).

To remove the humidifier:

1. Open the rear door and disconnect the main circuit breaker.
2. Drain all the water from the cylinder by turning the power switch to 1. [Refer to Figure 7.2](#) to locate the power switch in each CoolPhase Row version.
3. Disconnect the steam hose (made of non-conductive rubber).
4. Disconnect the power electrode wires and level sensor wires.
5. Release the cylinder from the brackets.
6. Pull the cylinder out of its gland.

Figure 10.2 Removing Humidifier

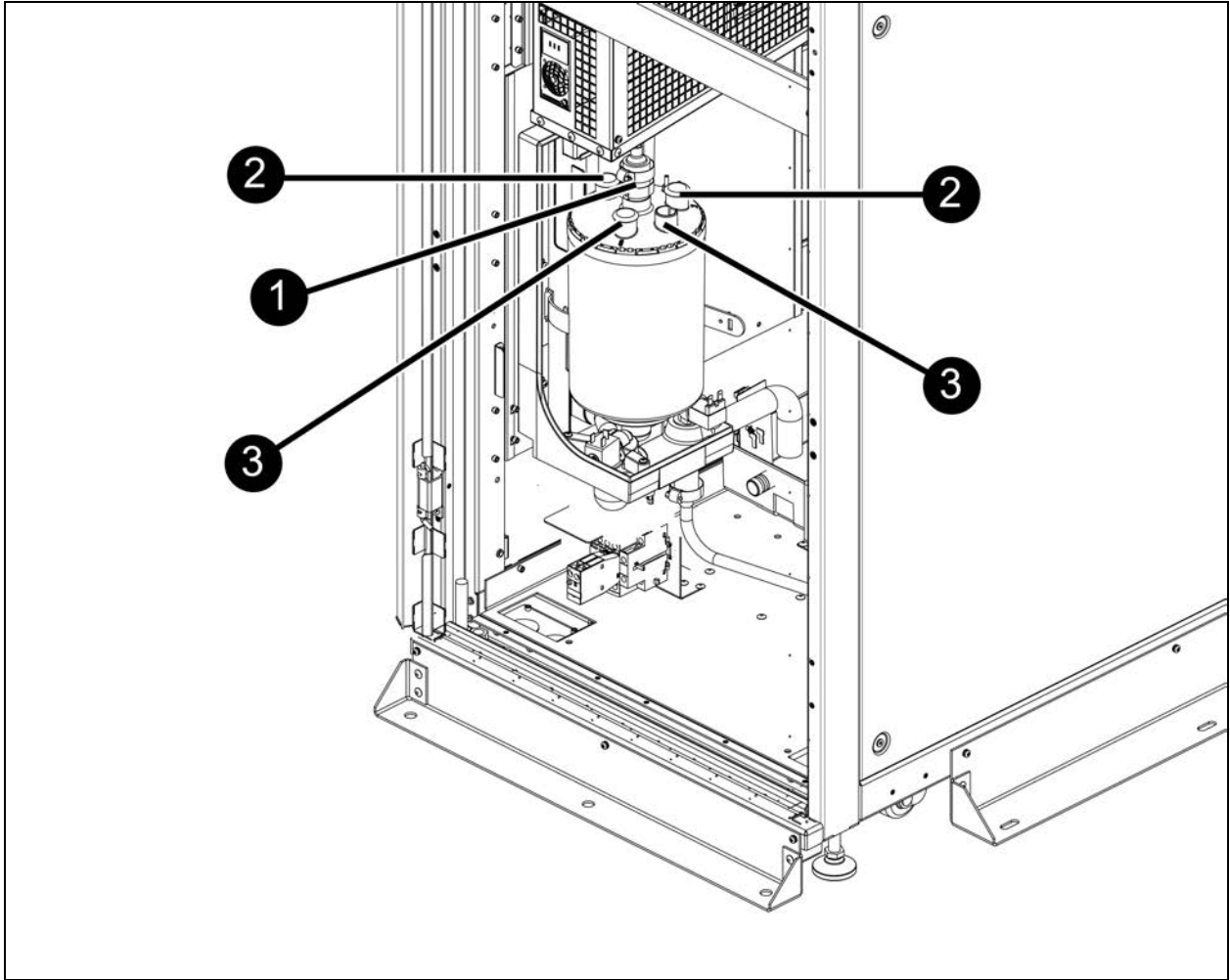

Item	Description	Item	Description
1	Steam hose connection	3	Power electrode wire connection
2	Level sensor wire connection	-	

NOTE: After replacing the humidifier cylinder, clear the operating time of the humidifier. Press the menu button on the HMI display, choose Maintenance > Parameter Reset, and select Yes for Confirm Humidifier Maintenance.

10.5 Refrigeration Circuit



WARNING! Systems that have a charge less than 35 lbs (15.9 kg) of refrigerant may be located within unventilated areas. Unventilated area where the appliance is to be installed shall be so constructed that any refrigerant will not stagnate to create a fire or explosion hazard.



WARNING! Systems that have a charge above 35 lbs (15.9 kg) of refrigerant shall be located inside rooms with additional ventilation.



WARNING! If the unit remains off for more than 8 hours for service, the refrigerant must be evacuated from the system.

These instructions must be followed when the system is installed, serviced or decommissioned:

- The refrigerant charge shall be recovered into the correct recovery cylinders.
- System shall be purged with oxygen-free nitrogen to render the appliance safe for flammable refrigerants. This process might need to be repeated several times. Compressed air or oxygen shall not be used for purging refrigerant systems.
- Refrigerant purging shall be achieved by breaking the vacuum in the system with oxygen-free nitrogen and continuing to fill until the working pressure is achieved, then venting to atmosphere, and finally pulling down to a vacuum. This process shall be repeated until no refrigerant is within the system. When the final oxygen-free nitrogen charge is used, the system shall be vented down to atmospheric pressure to enable work to take place. This operation is vital if brazing operations on the pipework are to take place.
- The outlet for the vacuum pump shall not be close to any potential ignition sources, and ventilation shall be available.

When breaking into the refrigerant circuit to make repairs – or for any other purpose – conventional procedures shall be used. However, for flammable refrigerants it is important that best practice is followed since flammability is a consideration. The following procedure shall be adhered to:

- Safely remove refrigerant following local and national regulations
- Evacuate.
- Purge the circuit with inert gas
- Evacuate
- Continuously flush or purge with inert gas when using flame to open circuit; and
- Open the circuit by cutting or brazing.

NOTICE

The refrigerant charge shall be recovered into the correct recovery cylinders. For appliances containing flammable refrigerants other than A2L refrigerants, the system shall be purged with oxygen-free nitrogen to render the appliance safe for flammable refrigerants. This process may need to be repeated several times. Compressed air or oxygen shall not be used for purging refrigerant systems. Ensure that the outlet for the vacuum pump is not close to any potential ignition sources and that ventilation is available.

Note the following when maintaining the refrigerant circuit:

- When repairing the refrigeration circuit, collect all refrigerant in a container and do not allow the refrigerant to escape.
- When either removing (for repairs) or charging refrigerant, this must be performed on both the high- and low-pressure sides of the compressor simultaneously.
- If it is necessary to replace or remove the compressor, the copper plated steel connections should be brazed with a Silfos material containing a minimum of 5% silver.

10.6 Dismantling The Unit



CAUTION: Before carrying out this procedure, it is essential that the technician is completely familiar with the equipment and all its detail. It is recommended good practice that all refrigerants are recovered safely. Prior to the task being carried out, an oil and refrigerant sample shall be taken in case analysis is required prior to re-use of recovered refrigerant. It is essential that electrical power is available before the task is commenced.



CAUTION: The unit contains substances and components hazardous for the environment (electronic components, refrigerating gases and oils). At the end of the useful life, when the unit is dismantled, the operation must be carried out by specialized refrigerating technicians. Any component that is removed must be taken to collection and disposal centers specialized in the collection and disposal of equipment containing hazardous substances. The refrigerating fluid and the lubricating oil inside the circuit must be recovered according to the laws in force in the relevant country.

These instructions must be followed when dismantling the unit:

- Become familiar with the equipment and its operation.
- Isolate system electrically.
- Before attempting the procedure, ensure that:
 - a. Mechanical handling equipment is available, if required, for handling refrigerant cylinders.
 - b. All personal protective equipment is available and being used correctly.
 - c. A competent person supervises the recovery process at all times.
 - d. Recovery equipment and cylinders conform to the appropriate standards.
- Pump down the refrigerant system, if possible.
- If a vacuum is not possible, make a manifold so that refrigerant can be removed from various parts of the system
- Make sure that the cylinder is situated on the scales before recovery occurs.
- Start the recovery machine and operate in accordance with instructions.
- When the cylinders have been filled correctly and the process completed, make sure that the cylinders and the equipment are removed from site promptly and all isolation valves on the equipment are closed off.
- Recovered refrigerant shall not be charged into another refrigerating system unless it has been cleaned and checked.
- Do not overfill cylinders (no more than 80 % volume liquid charge).
- Do not exceed the maximum working pressure of the cylinder, even temporarily.
- When the cylinders have been filled correctly and the process completed, make sure that the cylinders and the equipment are removed from site promptly and all isolation valves on the equipment are closed off.

NOTICE

When removing refrigerant from a system, either for servicing or decommissioning, it is recommended good practice that all refrigerants are removed safely.

NOTICE

When transferring refrigerant into cylinders, ensure that only appropriate refrigerant recovery cylinders are employed. Ensure that the correct number of cylinders for holding the total system charge is available. All cylinders to be used are designated for the recovered refrigerant and labelled for that refrigerant (i.e. special cylinders for the recovery of refrigerant). Cylinders shall be complete with pressure-relief valve and associated shut-off valves in good working order. Empty recovery cylinders are evacuated and, if possible, cooled before recovery occurs.

NOTICE

The recovery equipment shall be in good working order with a set of instructions concerning the equipment that is at hand and shall be suitable for the recovery of the flammable refrigerant. If in doubt, the manufacturer should be consulted. In addition, a set of calibrated weighing scales shall be available and in good working order. Hoses shall be complete with leak-free disconnect couplings and in good condition.

NOTICE

The recovered refrigerant shall be processed according to local legislation in the correct recovery cylinder, and the relevant waste transfer note arranged. Do not mix refrigerants in recovery units and especially not in cylinders.

NOTICE

If compressors or compressor oils are to be removed, ensure that they have been evacuated to an acceptable level to make certain that flammable refrigerant does not remain within the lubricant. The compressor body shall not be heated by an open flame or other ignition sources to accelerate this process. When oil is drained from a system, it shall be carried out safely.

NOTE: Equipment shall be labeled stating that it has been de-commissioned and emptied of refrigerant. The label shall be dated and signed. For appliances containing flammable refrigerants, ensure that there are labels on the equipment stating the equipment contains flammable refrigerant.

NOTICE

Please be environmentally responsible and recycle this product through your recycling facility at its end of life. Do not dispose of this product as unsorted municipal waste. Follow local municipal waste ordinances for proper disposal provisions to reduce the environmental impact of Waste Electrical and Electronic Equipment (WEEE).

This unit contains refrigerant and other potentially dangerous materials. Do not dispose this product as unsorted municipal waste. Follow local municipal waste ordinances for proper disposal provisions to reduce the environmental impact of waste electrical and electronic equipment.

The machine has been designed and built to ensure continuous operation. The working life of some of the main components, such as the fan and the compressor, depends on the operating condition and maintenance that they receive.

11 Troubleshooting

The table below lists possible issues and their cause and corrective steps.

Table 11.1 Troubleshooting

Problem	Possible Cause	Corrective Action	
Rack temperature is too high	Dirty filters	Replace filters	
	Filter clog sensor	Call Vertiv Technical Support	
	Incorrect position of remote temperature sensors	Verify that remote temperature sensors are correctly positioned	
	Remote temperature sensor issue	Call Vertiv Technical Support	
	Condensation pressure too high	Verify remote condenser fans are running	
	Refrigerating circuit charge issue	Call Vertiv Technical Support	
	Cold air short-cycling issues	Verify unit positioning/room configuration	
		Verify unit air-baffles set-up	
		Verify cold aisle containment seals (if applicable)	
	Insufficient room cooling capacity	Reduce rack heat load or add cooling units	
Unit safety device intervention	Contact your local Vertiv representative		
Unit fan fail to start	The fan is faulty	Call Vertiv Technical Support	
Water drops carried by airflow	Room humidity is over acceptable limit	Check room condition	
	Condensate pan drain is clogged	Call Vertiv Technical Support	
	Problem to humidifier control		
Water on the floor around the unit	Unit is not properly levelled	Adjust the levelling feet	
	Unit condensate drain pipe is clogged	Remove pipe obstruction	
	Piping insulation broken/damaged	Restore insulation integrity	
	Leak in the draining circuit	Call Vertiv Technical Support	
	Condensate pump is faulty		
	Leak in the humidifier filling hose		
Cooling Unit noise level is too high than expected	Incorrect positioning of remote temperature sensors	Verify that remote temperature sensors are correctly positioned	
	Unbalanced heat load distribution	Enhance racks heat load distribution	
	Remote temperature sensor/s issue	Call Vertiv Technical Support	
Unsteady air delivery temperature	Faulty temperature sensor	Call Vertiv Technical Support	
	Unit Vertiv™ iCOM™ issue.		

Table 11.1 Troubleshooting (continued)

Problem	Possible Cause	Corrective Action
Local display not operational but unit operates	Local display cable disconnected	Connect the cable
	Local display cable damaged	Replace the cable
	Local display configuration lost	Call Vertiv Technical Support
HMI display does not operate and the unit does not operate	Unit electrical supply is off	Restore electrical supply
	Unit main switch is off	Switch on the unit
	Control board supply issue	Call Vertiv Technical Support
	Control board issue	

This page intentionally left blank

Appendices

Appendix A: Technical Support and Contacts

A.1 Technical Support/Service in the United States

Vertiv Group Corporation

24x7 dispatch of technicians for all products.

1-800-543-2378

Liebert® Thermal Management Products

1-800-543-2778

Liebert® Channel Products

1-800-222-5877

Liebert® AC and DC Power Products

1-800-543-2378

A.2 Locations

United States

Vertiv Headquarters

505 N Cleveland Ave

Westerville, OH, 43082, USA

Europe

Via Leonardo Da Vinci 8 Zona Industriale Tognana

35028 Piove Di Sacco (PD) Italy

Asia

7/F, Dah Sing Financial Centre

3108 Gloucester Road, Wanchai

Hong Kong.

Appendix B: Alarm Table

Alarm	Alarm Conditions	Effect	Condition to clear the Alarm
High pressure alarm	<p>When the compressor contactor is closed, the alarm occurs when any of the following conditions is met:</p> <ol style="list-style-type: none"> 1. The auxiliary normally opened contact point is opened. The alarm detection delay expires. 2. When the compressor is running, the high-pressure sensor is effective, and the detected value is larger than "high pressure alarm value". <p>The alarm detection delay expires.</p>	The alarm occurs. The compressor stops immediately	<p>When the compressor contactor is closed, the alarm is cleared when all the following conditions are met:</p> <ol style="list-style-type: none"> 1. The auxiliary normally opened contact point is closed. The alarm detection delay expires. 2. The high-pressure sensor is ineffective, or the detected value is smaller than "high pressure alarm value - offset". The alarm detection delay expires.
Low pressure alarm	<p>The alarm occurs when all the following conditions are met:</p> <ol style="list-style-type: none"> 1. The compressor is running 2. The compressor is not in soft stop state 3. Low pressure is smaller than "low pressure alarm value". The alarm detection delay expires (the 2nd phase of soft start has completed. The alarm detection delay expires.) 	The alarm occurs. The compressor stops immediately	<p>The alarm is cleared when any of the following conditions is met:</p> <ol style="list-style-type: none"> 1. Low pressure sensor is ineffective 2. Low pressure is smaller than "low pressure alarm value + offset". The alarm detection delay expires.
Discharge high temperature alarm	<p>The alarm occurs when all the following conditions are met:</p> <ol style="list-style-type: none"> 1. The compressor is running 2. Discharge temperature is higher than "discharge high temperature alarm value". The alarm detection delay expires. 	The alarm occurs. The compressor stops immediately	<p>The alarm is cleared when any of the following conditions is met:</p> <ol style="list-style-type: none"> 1. Discharge temperature sensor is ineffective 2. Discharge temperature is smaller than "discharge high temperature alarm value "- offset". The alarm detection delay expires.
Low discharge superheat	<p>The alarm occurs when all the following conditions are met:</p> <ol style="list-style-type: none"> 1. The compressor is running. The compressor is not in soft stop state. 2. High pressure sensor and discharge temperature sensor are effective. The discharge superheat is smaller than alarm value. The alarm detection delay expires (the 2nd phase of soft start has completed. The "low discharge superheat alarm start delay" expires) 	The alarm occurs. The compressor stops immediately	The alarm is cleared 60s after the compressor stops
High pressure lock	The alarm occurs when the high-pressure alarm occurs 3 times within 1 hour or the alarm occur for 10 min	The alarm occurs. The compressor is locked and stops working	The alarm is cleared when the unit is powered on again or user clear the alarm on the HMI
Low pressure lock	The alarm occurs when the low-pressure alarm occurs 3 times within 1 hour or the alarm occur for 10 min	The alarm occurs. The compressor is locked and stops working	The alarm is cleared when the unit is powered on again or user clear the alarm on the HMI
Discharge high	The alarm occurs when the high temperature alarm	The alarm occurs. The compressor is	The alarm is cleared when the

Alarm	Alarm Conditions	Effect	Condition to clear the Alarm
temperature lock alarm	occurs 3 times within 24 hours .	locked and stops working	unit is powered on again or user clear the alarm on the HMI
Discharge low super heat lock alarm	The alarm occurs when the discharge low super heat alarm occurs 3 times within 1 hour.	The alarm occurs. The compressor is locked and stops working	The alarm is cleared when the unit is powered on again or user clear the alarm on the HMI
Return air high temperature alarm	The alarm occurs when, 5 min after the fan starts, the return air temperature is effective, and the detected value is higher than the alarm value. The alarm detection delay expires.	The alarm occurs	The alarm is cleared when: the return air temperature is invalid, or the return air temperature is smaller than “the alarm value – offset” and the alarm detection delay expires
Return air low temperature alarm	The alarm occurs when, 5 min after the fan starts, the return air temperature is effective, and the detected value is lower than the alarm value. The alarm detection delay expires.	The alarm occurs	The alarm is cleared when: the return air temperature is invalid, or the return air temperature is higher than “the current high temperature alarm value + offset” and the alarm detection delay expires
Supply air low temperature alarm	The alarm occurs when, 5 min after the fan starts, the supply air temperature is effective, and the detected value is higher than the alarm value. The alarm detection delay expires.	The alarm occurs. The compressor stops immediately	The alarm is cleared when: the supply air temperature is invalid, or the supply air temperature is higher than “the alarm value + offset” and the alarm detection delay expires
Supply air high temperature alarm	The alarm occurs when, 5 min after the fan starts, the supply air temperature is effective, and the detected value is lower than the alarm value. The alarm detection delay expires.	The alarm occurs	The alarm is cleared when: the supply air temperature is invalid, or the supply air temperature is smaller than “the alarm value – offset” and the alarm detection delay expires
Remote air high temperature alarm	The alarm occurs when, 15 min after the fan starts, the remote air temperature is effective, and the detected value is higher than the alarm value. The alarm detection delay expires.	The alarm occurs	The alarm is cleared when: the remote air temperature is invalid, or the remote air temperature is smaller than “the alarm value – offset” and the alarm detection delay expires.
Remote air low temperature alarm	The alarm occurs when, 15 min after the fan starts, the remote air temperature is effective, and the detected value is lower than the alarm value. The alarm detection delay expires.	The alarm occurs	The alarm is cleared when: the remote air temperature is invalid, or the remote air temperature is higher than “the alarm value + offset” and the alarm detection delay expires
Filter clogged alarm	The alarm occurs when the filter switch is closed. The alarm detection delay expires.	The alarm occurs	The alarm is cleared when: the filter switch is opened, and the alarm detection delay expires
Remote powering off alarm	The alarm occurs when the remote power on/off switch is different from the set value. The alarm detection delay expires.	The alarm occurs. The unit is stopped by remote powering off. The compressor performs soft stop	The alarm is cleared when: the remote power on/off switch is the same as the set value, and the alarm detection delay expires
Return air temperature	The alarm occurs when the return air temperature	The alarm occurs	The alarm is cleared when: the

Alarm	Alarm Conditions	Effect	Condition to clear the Alarm
sensor {n} failure	sensor {n} exceeds the detectable range. The alarm detection delay expires.		return air temperature sensor {n} reaches the detectable range, and the alarm detection delay expires
Return air humidity sensor failure alarm	The alarm occurs when the return air humidity sensor {n} exceeds the detectable range. The alarm detection delay expires.	The alarm occurs	The alarm is cleared when: the return air humidity sensor {n} reaches the detectable range, and the alarm detection delay expires
Supply air temperature sensor {n} failure	The alarm occurs when the supply air temperature sensor {n} exceeds the detectable range. The alarm detection delay expires.	The alarm occurs	The alarm is cleared when: the supply air temperature sensor {n} reaches the detectable range, and the alarm detection delay expires
Remote air temperature sensor {n} failure	The alarm occurs when the remote air temperature sensor {n} exceeds the detectable range. The alarm detection delay expires.	The alarm occurs	The alarm is cleared when: the remote air temperature sensor {n} reaches the detectable range, and the alarm detection delay expires
High pressure sensor failure	The alarm occurs when the main control board can communicate with the VFD and reads this alarm, or the high pressure exceeds the normal range.	The alarm occurs. The compressor immediately stops. The indoor fan runs at minimum speed. The outdoor fan runs at full speed	The alarm is cleared when: the high-pressure sensor {n} reaches the detectable range, and the alarm detection delay expires
Low pressure sensor failure	The alarm occurs when the main control board can communicate with the EEV, the compressor is not in soft start, soft stop, or evacuation state, the main control board reads this alarm, or the detected pressure exceeds the normal range.	The alarm occurs. The compressor immediately stops. The fan runs at minimum speed	The alarm is cleared when: the main board cannot communicate with the EEV, the main board does not read this alarm, or the detected pressure is within the normal range
Suction temperature sensor failure	The alarm occurs when the main control board can communicate with the EEV and reads this alarm, or the suction temperature exceeds the normal range.	The alarm occurs. The compressor immediately stops. The fan runs at minimum speed	The alarm is cleared when: the main board cannot communicate with the EEV, or the main board receives that the EEV failure is recovered
Discharge temperature sensor failure	The alarm occurs when the main control board can communicate with the VFD and reads this alarm, or the discharge temperature exceeds the normal range.	The alarm occurs. The compressor immediately stops. The fan runs at minimum speed	The alarm is cleared when the discharge temperature is within the detectable range and the alarm detection delay expires
EEV communication failure	The alarm occurs when the main control board cannot communicate with the EEV for 20s.	The alarm occurs. The compressor stops immediately	The alarm is cleared when the main control board can communicate with the EEV
Compressor driver communication failure	The alarm occurs when the compressor contactor is closed, the auxiliary normally closed contact point is closed, and the main control board cannot communicate with the compressor driver board for 30s.	The alarm occurs. The compressor maintains the current output. The fans run at rated speed	The alarm is cleared when the auxiliary normally closed contact point is closed, the main control board can communicate with the compressor driver board, and the alarm detection delay expires
Electric heater failure	The alarm occurs when the electric heater faulty dry point has an alarm event, and the alarm	The alarm occurs. The electric heater stops	The alarm is cleared when the electric heater stops, or the

Alarm	Alarm Conditions	Effect	Condition to clear the Alarm
	detection delay expires.		electric heater is powered on again
Water leakage alarm	The alarm occurs when the water leakage switch is closed, and the alarm detection delay expires.	The alarm occurs. The way to manage it: 0: alarm only; 1: stops the humidification and dehumidification; 2: stops the unit (except the pump). User can set. The default way is 1: stops the humidification and dehumidification. When the unit stops, the compressor stops immediately.	The alarm is cleared when the water leakage switch is opened, and the alarm detection delay expires
Return air high humidity alarm	The alarm occurs when the fan has started for 5 min, the return air humidity is higher than the alarm value, and the alarm detection delay expires.	The alarm occurs	The alarm is cleared when the return air humidity is ineffective or the return air humidity is smaller than “alarm value – offset”, and the alarm detection delay expires
Return air low humidity alarm	The alarm occurs when the fan has started for 5 min, the return air humidity is effective and smaller than the alarm value, and the alarm detection delay expires.	The alarm occurs	The alarm is cleared when the return air humidity is ineffective or the return air humidity is higher than “alarm value + offset”, and the alarm detection delay expires
Air flow loss alarm	Switch feedback type The alarm occurs when the fan has started for 10 min, the fan detection board communicates normally, all the fan speed is larger than 20%, all the fan failure alarm switch is different from the set value, and the alarm detection delay expires (standard value = 10 * fan curve gradient + fan frequency correction), and the alarm detection delay expires. The default is the speed mode.	The alarm occurs. All the components stop except the fan and pump. The compressor stops immediately	Switch mode The alarm is cleared when the fan stops, the fan detection board communicates normally, any fan failure alarm switch is the same as the set value, and the alarm detection delay expires. Speed mode The alarm is cleared when the fan stops, the fan detection board communicates normally, any of the fan speed feedback > 20%, and the alarm detection delay expires
Fan detection board communication failure	The alarm occurs when the main control board cannot communicate with the 10DI board for 20s.	The alarm occurs. The humidification, dehumidification, and heating stop. The fan runs according to rated speed when in high temperature, cooling, humidification, and dehumidification mode. The compressor runs according to demand output and the compressor demand speed ≤ compressor rated speed	The alarm is cleared when the main control board receives data from the 10DI
Fan {n} failure alarm	Switch feedback type	The alarm occurs. The way to manage it: 0: cooling only (stops humidification, dehumidification, and heating). Fan runs according to	Switch feedback type

Alarm	Alarm Conditions	Effect	Condition to clear the Alarm
	<p>The alarm occurs when, after the fan start delay, the fan speed $\geq 20\%$, fan {n} failure switch is different from the set value, and the alarm detection delay expires.</p> <p>Frequency feedback type</p> <p>The alarm occurs when, after the fan start delay, the fan speed $\geq 20\%$, fan {n} feedback frequency $< 50\%$ standard value (standard value = given value \times fan curve gradient + fan frequency correction), and the alarm detection delay expires.</p>	<p>"demand output + faulty fan quantity $\times 5\%$"; 1: stops the unit (except the pump). The default way is 0. When the unit stops, the compressor stops immediately</p>	<p>The alarm is cleared when: fan {n} failure switch is the same as the set value and the alarm detection delay expires, or fan speed $< 20\%$ (if the way to handle it is to stop the fan, the alarm is not cleared; if the way to handle it is to provide cooling, the alarm is cleared)</p> <p>Frequency feedback type</p> <p>The alarm occurs when: fan speed $> 20\%$ and fan {n} feedback frequency $> 70\%$ standard value, or fan speed $< 20\%$ (if the way to manage it is to stop the fan, the alarm is not cleared; if the way to manage it is to provide cooling, the alarm is cleared).</p>
Power loss alarm	The alarm occurs, when the unit is running, the power supply is disconnected and then resumes.	The alarm occurs	The alarm is cleared after 10s
Power over voltage alarm	The alarm occurs when the power input voltage is higher than over voltage alarm value and the alarm detection delay expires.	The alarm occurs. All the components are stopped	The alarm is cleared when the power input voltage is lower than the over voltage alarm value and the alarm detection delay expires
Power under voltage alarm	The alarm occurs when the power input voltage is lower than the under-voltage alarm value and the alarm detection delay expires.	The alarm occurs. All the components are stopped	The alarm is cleared when the power input voltage is higher than the under-voltage alarm value and the alarm detection delay expires
Power frequency offset alarm	The alarm occurs when the power frequency offset exceeds $\pm 3\text{Hz}$ and the alarm detection delay expires.	The alarm occurs. All the components are stopped	The alarm is cleared when the power frequency offset does not exceed $\pm 1.5\text{Hz}$ and the alarm detection delay expires
High condensate water alarm	The alarm occurs when the high condensate water level detection board switch is closed, and the alarm detection delay expires.	The alarm occurs. The compressor stops immediately	The alarm is cleared when the high condensate water level detection board switch is opened, and the alarm detection delay expires
Teamwork addresses duplicated	The alarm occurs when the unit receives the data frame that has the same address as itself.	The alarm occurs	The alarm is cleared when the unit does not receive the data frame that has the same address as itself within 60s
Teamwork primary unit loss	The alarm occurs when the secondary unit does not receive data from the primary unit within 60s in teamwork mode.	The alarm occurs. The secondary unit runs according to single unit mode	The alarm occurs when the secondary unit receives data from the primary unit
Teamwork secondary unit loss	The alarm occurs when the primary unit does not receive data from the secondary unit within 60s in teamwork mode.	The alarm occurs. The primary unit does not calculate the data of the secondary unit	The alarm occurs when the primary unit receives data from the secondary unit
Smoke alarm	The alarm occurs when the smoke sensor switch is	The alarm occurs	The alarm occurs when the

Alarm	Alarm Conditions	Effect	Condition to clear the Alarm
	different from the set value and the alarm detection delay expires.		smoke sensor switch is the same as the set value and the alarm detection delay expires
Fire alarm	The alarm occurs when the fire sensor switch is different from the set value and the alarm detection delay expires.	The alarm occurs. All the components are stopped	The alarm occurs when the fire sensor switch is the same as the set value and the alarm detection delay expires
Customized alarm	The alarm occurs when the customized switch is different from the set value and the alarm detection delay expires.	The alarm occurs	The alarm is cleared when the customized switch is the same as the set value and the alarm detection delay expires
Humidifier failure alarm	The alarm occurs when the humidifier failure switch is closed, and the alarm detection delay expires.	The alarm occurs	The alarm is cleared when the humidifier stops, the humidifier failure switch is opened, and the alarm detection delay expires
EEV driver abnormal	The alarm occurs when all the following conditions are met: 1. The compressor is running, and the compressor is not in EEV balanced state 2. EEV communicates normally 3. EEV actual opening degree is smaller than 8% .	The alarm occurs. The compressor stops immediately. The fan runs at minimum speed	The alarm is cleared when the compressor stops for 3s
Humidifier maintenance	The alarm occurs when the humidifier running time reaches the humidifier maintenance notification value.	The alarm occurs	The alarm is cleared when user clears the humidifier running time
Air pressure sensor failure	The alarm occurs when the air pressure exceeds the detectable range. The alarm detection delay expires.	The alarm occurs. The fan runs according to rated speed in single unit mode and the fan runs according to the allocated speed in teamwork unit mode	The alarm is cleared when the fan sensor quantity is set to 0 or the air pressure value is within the detectable range and the alarm detection delay expires
Power meter communication failure	The alarm occurs when the main control board cannot communicate with the power meter for 10s.	The alarm occurs	The alarm is cleared when the main control board can communicate with the power meter
Filter maintenance	The alarm occurs when the filter running time reaches the filter maintenance notification value.	The alarm occurs	The alarm is cleared when user clears the filter running time
Compressor OVERCURRENT	Communication reads that the compressor driver overcurrent alarm reaches the alarm detective delay time	The alarm is triggered, the compressor shuts down, and the indoor fan runs at standard speed	The compressor communication fails or the communication reads that the fault has been cleared
Compressor OVERVOLTAGE	Communication reads that the compressor driver overvoltage alarm reaches the alarm detective delay time	The alarm is triggered, the compressor shuts down, and the indoor fan runs at standard speed	The compressor communication fails or the communication reads that the fault has been cleared
Compressor PRECHARGE_FAULT	Communication reads that the compressor driver precharge_fault alarm reaches the alarm detective delay time	The alarm is triggered, the compressor shuts down, and the indoor fan runs at standard speed	The compressor communication fails or the communication reads that the fault has been cleared

Alarm	Alarm Conditions	Effect	Condition to clear the Alarm
Compressor UNDERVOLTAGE	Communication reads that the compressor driver undervoltage alarm reaches the alarm detective delay time	The alarm is triggered, the compressor shuts down, and the indoor fan runs at standard speed	The compressor communication fails or the communication reads that the fault has been cleared
Compressor AC_DRIVE_OVERLOAD	Communication reads that the compressor ac_drive_overload alarm reaches the alarm detective delay time	The alarm is triggered, the compressor shuts down, and the indoor fan runs at standard speed	The compressor communication fails or the communication reads that the fault has been cleared
Compressor MOTOR OVERLOAD	Communication reads that the compressor motor overload alarm reaches the alarm detective delay time	The alarm is triggered, the compressor shuts down, and the indoor fan runs at standard speed	The compressor communication fails or the communication reads that the fault has been cleared
Compressor INPUT_PH_LOSS	Communication reads that the Compressor input phase loss alarm reaches the alarm detective delay time	The alarm is triggered, the compressor shuts down, and the indoor fan runs at standard speed	The compressor communication fails or the communication reads that the fault has been cleared
Compressor OUTPUT_PH_LOSS	Communication reads that the Compressor output phase loss alarm reaches the alarm detective delay time	The alarm is triggered, the compressor shuts down, and the indoor fan runs at standard speed	The compressor communication fails or the communication reads that the fault has been cleared
Compressor OVERHEAT	Communication reads that the Compressor overheat alarm reaches the alarm detective delay time	The alarm is triggered, the compressor shuts down, and the indoor fan runs at standard speed	The compressor communication fails or the communication reads that the fault has been cleared
Compressor EXT_FAULT	Communication reads that the Compressor external fault alarm reaches the alarm detective delay time	The alarm is triggered, the compressor shuts down, and the indoor fan runs at standard speed	The compressor communication fails or the communication reads that the fault has been cleared
Compressor PRECHRG_CIRC_EXC	Communication reads that the Compressor PRECHRG_CIRC_EXC alarm reaches the alarm detective delay time	The alarm is triggered, the compressor shuts down, and the indoor fan runs at standard speed	The compressor communication fails or the communication reads that the fault has been cleared
Compressor CURR_SAMPLING_EXC	Communication reads that the Compressor current sampling abnormal alarm reaches the alarm detective delay time	The alarm is triggered, the compressor shuts down, and the indoor fan runs at standard speed	The compressor communication fails or the communication reads that the fault has been cleared
Compressor AUTOTUNE_EXC	Communication reads that the Compressor autotune abnormal alarm reaches the alarm detective delay time	The alarm is triggered, the compressor shuts down, and the indoor fan runs at standard speed	The compressor communication fails or the communication reads that the fault has been cleared
Compressor ENCODER_EXC	Communication reads that the Compressor encoder abnormal alarm reaches the alarm detective delay time	The alarm is triggered, the compressor shuts down, and the indoor fan runs at standard speed	The compressor communication fails or the communication reads that the fault has been cleared
Compressor EEPROM_FAULT	Communication reads that the Compressor EEPROM fault alarm reaches the alarm detective delay time	The alarm is triggered, the compressor shuts down, and the indoor fan runs at standard speed	The compressor communication fails or the communication reads that the fault has been cleared
Compressor ENCODER_NOT_ACT	Communication reads that the Compressor encoder not active alarm reaches the alarm detective delay time	The alarm is triggered, the compressor shuts down, and the indoor fan runs at standard speed	The compressor communication fails or the communication reads that the fault has been cleared
Compressor OUTPUT_SHORT_GROUND	Communication reads that the Compressor output short ground alarm reaches the alarm detective delay time	The alarm is triggered, the compressor shuts down, and the indoor fan runs at standard speed	The compressor communication fails or the communication reads that the fault has been cleared
Compressor ACCUM_RUN_REACH	Communication reads that the Compressor accum run reach alarm reaches the alarm detective delay time	The alarm is triggered, the compressor shuts down, and the indoor fan runs at standard speed	The compressor communication fails or the communication reads that the fault has been cleared

Alarm	Alarm Conditions	Effect	Condition to clear the Alarm
Compressor USER_DEF_FAULT	Communication reads that the Compressor user define fault reaches the alarm detective delay time	The alarm is triggered, the compressor shuts down, and the indoor fan runs at standard speed	The compressor communication fails or the communication reads that the fault has been cleared
Compressor USER_DEF_ALARM	Communication reads that the Compressor user define alarm reaches the alarm detective delay time	The alarm is triggered, the compressor shuts down, and the indoor fan runs at standard speed	The compressor communication fails or the communication reads that the fault has been cleared
Compressor ACCUM_POW_ON_REACH	Communication reads that the Compressor accum power on reach alarm reaches the alarm detective delay time	The alarm is triggered, the compressor shuts down, and the indoor fan runs at standard speed	The compressor communication fails or the communication reads that the fault has been cleared
Compressor OUTPUT_LD_LOSS	Communication reads that the Compressor output all three phases loss alarm reaches the alarm detective delay time	The alarm is triggered, the compressor shuts down, and the indoor fan runs at standard speed	The compressor communication fails or the communication reads that the fault has been cleared
Compressor PID_FDBK_LOSS	Communication reads that the Compressor PID feedback loss alarm reaches the alarm detective delay time	The alarm is triggered, the compressor shuts down, and the indoor fan runs at standard speed	The compressor communication fails or the communication reads that the fault has been cleared
Compressor PARAM_EXC	Communication reads that the Compressor parameter abnormal alarm reaches the alarm detective delay time	The alarm is triggered, the compressor shuts down, and the indoor fan runs at standard speed	The compressor communication fails or the communication reads that the fault has been cleared
Compressor PULSE_CURR_LIM_FAULT	Communication reads that the Compressor pulse current limit fault alarm reaches the alarm detective delay time	The alarm is triggered, the compressor shuts down, and the indoor fan runs at standard speed	The compressor communication fails or the communication reads that the fault has been cleared
Compressor SPEED_DEVIATON	Communication reads that the Compressor speed overdeviation alarm reaches the alarm detective delay time	The alarm is triggered, the compressor shuts down, and the indoor fan runs at standard speed	The compressor communication fails or the communication reads that the fault has been cleared
Compressor MOTOR_OVERSPEED	Communication reads that the Compressor motor overspeed alarm reaches the alarm detective delay time	The alarm is triggered, the compressor shuts down, and the indoor fan runs at standard speed	The compressor communication fails or the communication reads that the fault has been cleared
Compressor MOTOR_OVERTEMP	Communication reads that the Compressor motor over temperature alarm reaches the alarm detective delay time	The alarm is triggered, the compressor shuts down, and the indoor fan runs at standard speed	The compressor communication fails or the communication reads that the fault has been cleared
Compressor STO_FAULT	Communication reads that the Compressor STO fault alarm reaches the alarm detective delay time	The alarm is triggered, the compressor shuts down, and the indoor fan runs at standard speed	The compressor communication fails or the communication reads that the fault has been cleared
Compressor POLE_POS_ERROR	Communication reads that the Compressor pole position error alarm reaches the alarm detective delay time	The alarm is triggered, the compressor shuts down, and the indoor fan runs at standard speed	The compressor communication fails or the communication reads that the fault has been cleared
Compressor MSTR_SLV_CTRL_FAULT	Communication reads that the Compressor master slave control fault alarm reaches the alarm detective delay time	The alarm is triggered, the compressor shuts down, and the indoor fan runs at standard speed	The compressor communication fails or the communication reads that the fault has been cleared
Compressor SELF_CHECK_FAULT1	Communication reads that the Compressor self check fault1 alarm reaches the alarm detective delay time	The alarm is triggered, the compressor shuts down, and the indoor fan runs at standard speed	The compressor communication fails or the communication reads that the fault has been cleared
Compressor SELF_CHECK_FAULT2	Communication reads that the Compressor self check fault2 alarm reaches the alarm detective delay time	The alarm is triggered, the compressor shuts down, and the indoor fan runs at standard speed	The compressor communication fails or the communication reads that the fault has been cleared

Alarm	Alarm Conditions	Effect	Condition to clear the Alarm
Compressor SELF_CHECK_FAULT3	Communication reads that the Compressor self check fault3 alarm reaches the alarm detective delay time	The alarm is triggered, the compressor shuts down, and the indoor fan runs at standard speed	The compressor communication fails or the communication reads that the fault has been cleared
Compressor SELF_CHECK_FAULT4	Communication reads that the Compressor self check fault4 alarm reaches the alarm detective delay time	The alarm is triggered, the compressor shuts down, and the indoor fan runs at standard speed	The compressor communication fails or the communication reads that the fault has been cleared
Compressor BRAKING_OVERLOAD	Communication reads that the Compressor braking overload alarm reaches the alarm detective delay time	The alarm is triggered, the compressor shuts down, and the indoor fan runs at standard speed	The compressor communication fails or the communication reads that the fault has been cleared
Compressor BRAKING_TRANS_FAULT	Communication reads that the Compressor braking trans fault alarm reaches the alarm detective delay time	The alarm is triggered, the compressor shuts down, and the indoor fan runs at standard speed	The compressor communication fails or the communication reads that the fault has been cleared
Compressor EXTERNAL_ALARMS	Communication reads that the Compressor external alarms reaches the alarm detective delay time	The alarm is triggered, the compressor shuts down, and the indoor fan runs at standard speed	The compressor communication fails or the communication reads that the fault has been cleared
Compressor PRECHRG_CONT_FAULT	Communication reads that the Compressor prechg contactor alarm reaches the alarm detective delay time	The alarm is triggered, the compressor shuts down, and the indoor fan runs at standard speed	The compressor communication fails or the communication reads that the fault has been cleared
Compressor TIMING_FAULT	Communication reads that the Compressor timing fault alarm reaches the alarm detective delay time	The alarm is triggered, the compressor shuts down, and the indoor fan runs at standard speed	The compressor communication fails or the communication reads that the fault has been cleared
Compressor MOTOR_CTRL_EXC1	Communication reads that the Compressor motor control abnormal alarm reaches the alarm detective delay time	The alarm is triggered, the compressor shuts down, and the indoor fan runs at standard speed	The compressor communication fails or the communication reads that the fault has been cleared
Compressor MOTOR_CTRL_EXC2	Communication reads that the Compressor motor control abnormal alarm reaches the alarm detective delay time	The alarm is triggered, the compressor shuts down, and the indoor fan runs at standard speed	The compressor communication fails or the communication reads that the fault has been cleared
Compressor AUTO_RST_FAIL	Communication reads that the Compressor auto reset fail alarm reaches the alarm detective delay time	The alarm is triggered, the compressor shuts down, and the indoor fan runs at standard speed	The compressor communication fails or the communication reads that the fault has been cleared
Compressor MODBUS_TO	Communication reads that the Compressor modbus timeout alarm reaches the alarm detective delay time	The alarm is triggered.	The compressor communication fails or the communication reads that the fault has been cleared
Compressor CANOPEN_FAULT	Communication reads that the Compressor canopen fault alarm reaches the alarm detective delay time	The alarm is triggered.	The compressor communication fails or the communication reads that the fault has been cleared
Compressor CANLINK_FAULT	Communication reads that the Compressor canlink fault alarm reaches the alarm detective delay time	The alarm is triggered.	The compressor communication fails or the communication reads that the fault has been cleared
Compressor EXP_CARD_FAULT	Communication reads that the Compressor expansion card fault alarm reaches the alarm detective delay time	The alarm is triggered.	The compressor communication fails or the communication reads that the fault has been cleared
Compressor INPUT_EXC_PROTECTION	Communication reads that the Compressor input abnormal protection alarm reaches the alarm detective delay time	The alarm is triggered.	The compressor communication fails or the communication reads that the fault has been cleared

Appendix C: Submittals Drawings

Document Number	Title
Standard and Optional Features	
Air Cooled 600 mm (24 inch) Models	
20000140	Standard and Optional Features 24 in (600 mm) Air Cooled Models.
Air Cooled 300 mm (12 inch) Models	
20000139	Standard and Optional Features 12 in (300 mm) Air Cooled Models
Component Locations	
20000303	Component Location, 24 in (600 mm) Air Cooled Models
20000304	Component Location, 12 in (300 mm) Air Cooled Models
Planning Dimensions	
20000144	Cabinet Dimensional Data 24 in (600 mm) models
20000145	Cabinet Dimensions CoolPhase Row 030 kW
Piping Schematics and Connection Locations - Air Cooled Systems	
20000141	General Arrangement Diagram CRD 030-040 kW CoolPhase Row
20000142	Primary Connection Locations, 24 in (600 mm) Air Cooled Models
20000143	Primary Connection Locations, 12 in (300 mm) Air Cooled Models
20000324	Air Cooled CoolPhase Row Piping Schematic Condenser Above Indoor Unit
Electric Field Connections – 600 mm (24 inch) / 300 mm (12 inch) Models	
20000325	CoolPhase Row 12in/ 24in (300/ 600 mm) Electrical Field Connections and Terminals blocks
Non-Seismic Application	
600 mm (24 inch) Models	
20000307	Dimensional Data 24 in (600 mm) rigid floor mount bracket
300 mm (12 inch) Models	
20000309	Dimensional Data 12 in (300 mm) rigid floor mount bracket
Electrical Schematics	
10080202	CoolPhase Row 40kW 460V 3PH 50-60HZ
10080203	CoolPhase Row 30kW 460V 3PH 50-60HZ
10080204	CoolPhase Row 40kW 208-230V 3PH 50-60HZ
10080205	CoolPhase Row 30kW 208-230V 3PH 50-60HZ
10080206	CoolPhase Row 40kW 208-230V 1PH 50-60HZ
10080207	CoolPhase Row 30kW 208-230V 1PH 50-60HZ
10159904	DVI-Dual Link Digital and Analog Monitor Cable
DX Products with R-32	
20000457	A2L refrigerant dispersal volume calculation R-32.

This page intentionally left blank



VERTIV COOLPHASE ROW

STANDARD FEATURES 600mm (24in) AIR COOLED MODELS

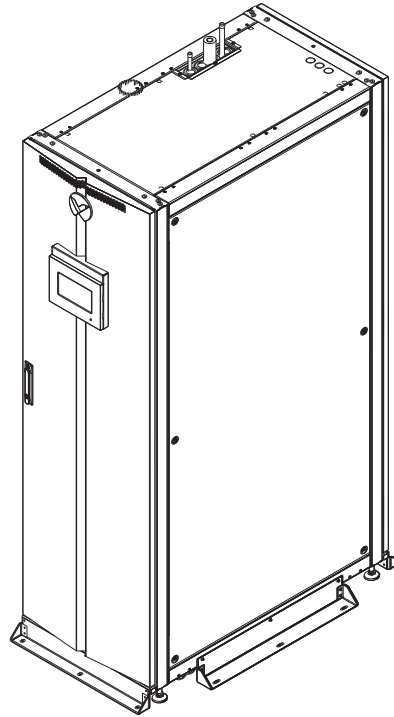

STANDARD FEATURES (Refer to product data sheet for options supplied)

DX COOLING COIL. The evaporator coil has 11.39 ft² (1.05 m²) face area, 6 rows deep. It is constructed of copper tubes and hydrophilic coated aluminium fins. The hydrophilic coating provides superior water carryover resistance. Two stainless steel condensate drain pans are provided.

REFRIGERATION SYSTEM. Single refrigeration circuit includes a liquid line filter drier, a refrigerant sight glass with moisture indicator an adjustable externally equalized expansion valve, and a liquid line solenoid valve.

FAN. The unit is equipped with eight plug fans: direct driven centrifugal fans with backward curved blades and Electronically Commutated DC motors; commonly referred to as EC plug fans. The fan speed is variable and automatically regulated by the Liebert[®] iCOM control through all modes of operation. Each fan has a dedicated motor and speed controller which provides a level of redundancy. The fans pull air through the coil and are located in front of the unit.

SUPPLY AIR BAFFLE A field adjustable, modular supply air baffle is located in the discharge air stream. It can be quickly and easily reconfigured to redirect airflow. The angles of the vanes have been optimized to effectively distribute air to heat generating equipment in a wide variety of applications.

LIEBERT[®] iCOM[™] CONTROL SYSTEM. The Vertiv CoolPhase Row is controlled by the Liebert[®] iCOM[™] Control System. The standard user interface is a 7 inch color HMI touch screen which presents system information and allows all parameters to be viewed and adjusted. It features a 3-level password protection system. Unit-to-Unit communication with other Vertiv CoolPhase Row's and a Liebert[®] IntelliSlot communication are included as standard.



VERTIV COOLPHASE ROW

STANDARD FEATURES 600mm (24in) AIR COOLED MODELS

REMOTE SHUTDOWN TERMINAL. Provides the customer with a location to remotely shut down the unit.

COMMON ALARM CONTACT. Provides the customer with one normally open (n/o) contact for remote alarm indication of the unit.

CABINET. The exterior steel panels are custom powder coated to protect against corrosion. The double wall constructed side panels separate the ½ inch, 2.0 lb/ft³ insulation from the airstream. The unit is mounted on casters for quick installation and provided with levelling feet. The perforated inlet and outlet panels have 81% open area, and the rear door utilizes a Swing Handle and hinges.

SERVICE ACCESS. All service and maintenance is performed through the front and rear of the unit; including any component removal. No side access is required. All electrical and piping connections are made through the top and/or bottom of the unit. All units are provided with a Superior Service Access Panel to provide additional access.

FILTER. The unit is equipped with two deep pleated 2inch filters rated MERV8 (based on ASHRAE 52.2-2012), located within the cabinet, and accessible from the rear of the unit. A filter clog alarm is included.

LOCKING DISCONNECT SWITCH. A moulded case circuit interrupter disrupts the flow of power to the unit. The electric panel high voltage compartment can only be accessed with the switch in the 'off' position. Conveniently located behind the rear service door for quick access.

65,000 AMP SHORT CIRCUIT CURRENT RATING (SCCR). The electrical panel provides a 65k amp SCCR.

DUAL-FLOAT CONDENSATE PUMP. It has a capacity of 2.64 GPM (10 L/min) at 6m head. Pump is complete with integral primary and secondary float switches, pump, brushless motor assembly, and reservoir. The secondary float shall send a signal to the local alarm and shut down the unit upon high water condition.



VERTIV COOLPHASE ROW

OPTIONAL FEATURES 600mm (24in) AIR COOLED MODELS

OPTIONAL FEATURES (Refer to product data sheet for options supplied)

HUMIDIFIER. A steam generating canister humidifier is factory-installed in the cooling unit and is operated by the Liebert® iCOM™ control system. It is complete with disposable cylinder, all supply and drain valves, steam distributor and electronic controls. The need to change the canister is indicated on the Liebert® iCOM™ display. The humidifier is designed to operate with water conductivity from 350-1250 $\mu\text{S}/\text{cm}$. System automatically fills and drains as well as maintains the required water level based on conductivity. An air-gap within the humidifier assembly shall prevent backflow of the humidifier supply water. The humidifier is removable from the rear of the cabinet.

ELECTRIC REHEAT. The electric reheat coils are low watt density, 304 stainless steel fin-tubular construction, protected by thermal safety switches and controlled in one stage.

REHEAT / HUMIDIFIER LOCKOUT. Includes the necessary relays to disable the reheat and humidifier from an external 24 volt signal.

REMOTE TEMPERATURE SENSORS. The unit can be connected up to ten 10 temperature sensors. The sensors provide real-time, direct feedback to the cooling unit to optimize the amount of cooling and airflow required; increasing energy efficiency and ensuring proper rack inlet air temperatures. The sensor data can also be reported to remote monitoring systems. The sensor network consists of one CAN wire leaving the cooling unit and connecting to a 2T sensor.



VERTIV COOLPHASE ROW

STANDARD FEATURES 300mm (12in) AIR COOLED MODELS

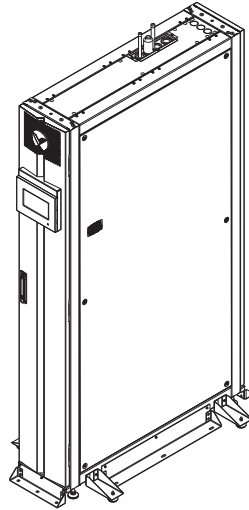

STANDARD FEATURES

(Refer to product data sheet for options supplied)

DX COOLING COIL. The evaporator has a V-shaped Coil with (1.8m) 5.9ft of height, 3 rows deep. It is constructed of copper tubes and hydrophilic coated aluminium fins. The hydrophilic coating provides superior water carryover resistance. Two stainless steel condensate drain pans are provided.

REFRIGERATION SYSTEM. Single refrigeration circuit includes a liquid line filter drier, a refrigerant sight glass with moisture indicator an adjustable externally equalized expansion valve, and a liquid line solenoid valve.

FAN. The unit is equipped with six plug fans: direct driven centrifugal fans with backward curved blades and Electronically Commutated DC motors; commonly referred to as EC plug fans. The fan speed is variable and automatically regulated by the Liebert® iCOM control through all modes of operation. Each fan has a dedicated motor and speed controller which provides a level of redundancy. The fans pull air through the coil and are located in front of the unit.

SUPPLY AIR BAFFLE A field adjustable, modular supply air baffle is located in the discharge air stream. It can be quickly and easily reconfigured to redirect airflow. The angles of the vanes have been optimized to effectively distribute air to heat generating equipment in a wide variety of applications.

LIEBERT® iCOM™ CONTROL SYSTEM. The Vertiv CoolPhase Row is controlled by the Liebert® iCOM™ Control System. The standard user interface is a 7 inch color HMI touch screen which presents system information and allows all parameters to be viewed and adjusted. It features a 3-level password protection system. Unit-to-Unit communication with other Vertiv CoolPhase Row's and a Liebert® IntelliSlot communication are included as standard.



VERTIV COOLPHASE ROW

STANDARD FEATURES 300mm (12in) AIR COOLED MODELS

REMOTE SHUTDOWN TERMINAL. Provides the customer with a location to remotely shut down the unit.

COMMON ALARM CONTACT. Provides the customer with one normally open (n/o) contact for remote alarm indication of the unit.

CABINET. The exterior steel panels are custom powder coated to protect against corrosion. The double wall constructed side panels separate the ½ inch, 2.0 lb/ft³ insulation from the airstream. The unit is mounted on casters for quick installation and provided with levelling feet. The perforated inlet and outlet panels have 81% open area, and the rear door utilizes a Swing Handle and hinges.

SERVICE ACCESS. All service and maintenance is performed through the front and rear of the unit; including any component removal. No side access is required. All electrical and piping connections are made through the top and/or bottom of the unit. All units are provided with a Superior Service Access Panel to provide additional access.

FILTER. The unit is equipped with two deep pleated 2 inch filters rated MERV8 (based on ASHRAE 52.2-2012), located within the cabinet, and accessible from the rear of the unit. A filter clog alarm is included.

LOCKING DISCONNECT SWITCH. A moulded case circuit interrupter disrupts the flow of power to the unit. The electric panel high voltage compartment can only be accessed with the switch in the 'off' position. Conveniently located behind the rear service door for quick access.

65,000 AMP SHORT CIRCUIT CURRENT RATING (SCCR). The electrical panel provides a 65k amp SCCR.

DUAL-FLOAT CONDENSATE PUMP. It has a capacity of 2.64 GPM (10 L/min) at 6m head. Pump is complete with integral primary and secondary float switches, pump, brushless motor assembly, and reservoir. The secondary float shall send a signal to the local alarm and shut down the unit upon high water condition.



VERTIV COOLPHASE ROW

OPTIONAL FEATURES 300mm (12in) AIR COOLED MODELS

OPTIONAL FEATURES (Refer to product sheet for options supplied)

HUMIDIFIER. A steam generating canister humidifier is factory-installed in the cooling unit and is operated by the Liebert® iCOM™ control system. It is complete with disposable cylinder, all supply and drain valves, steam distributor and electronic controls. The need to change the canister is indicated on the Liebert® iCOM™ display. The humidifier is designed to operate with water conductivity from 350-1250 $\mu\text{S}/\text{cm}$. System automatically fills and drains as well as maintains the required water level based on conductivity. An air-gap within the humidifier assembly shall prevent backflow of the humidifier supply water. The humidifier is removable from the rear of the cabinet.

ELECTRIC REHEAT. The electric reheat coils are low watt density, 304 stainless steel fin-tubular construction, protected by thermal safety switches and controlled in one stage.

REHEAT / HUMIDIFIER LOCKOUT. Includes the necessary relays to disable the reheat and humidifier from an external 24 volt signal.

REMOTE TEMPERATURE SENSORS. The unit can be connected up to ten 10 temperature sensors. The sensors provide real-time, direct feedback to the cooling unit to optimize the amount of cooling and airflow required; increasing energy efficiency and ensuring proper rack inlet air temperatures. The sensor data can also be reported to remote monitoring systems. The sensor network consists of one CAN wire leaving the cooling unit and connecting to a 2T sensor.

COMPONENT LOCATION 600mm (24in.) MODELS

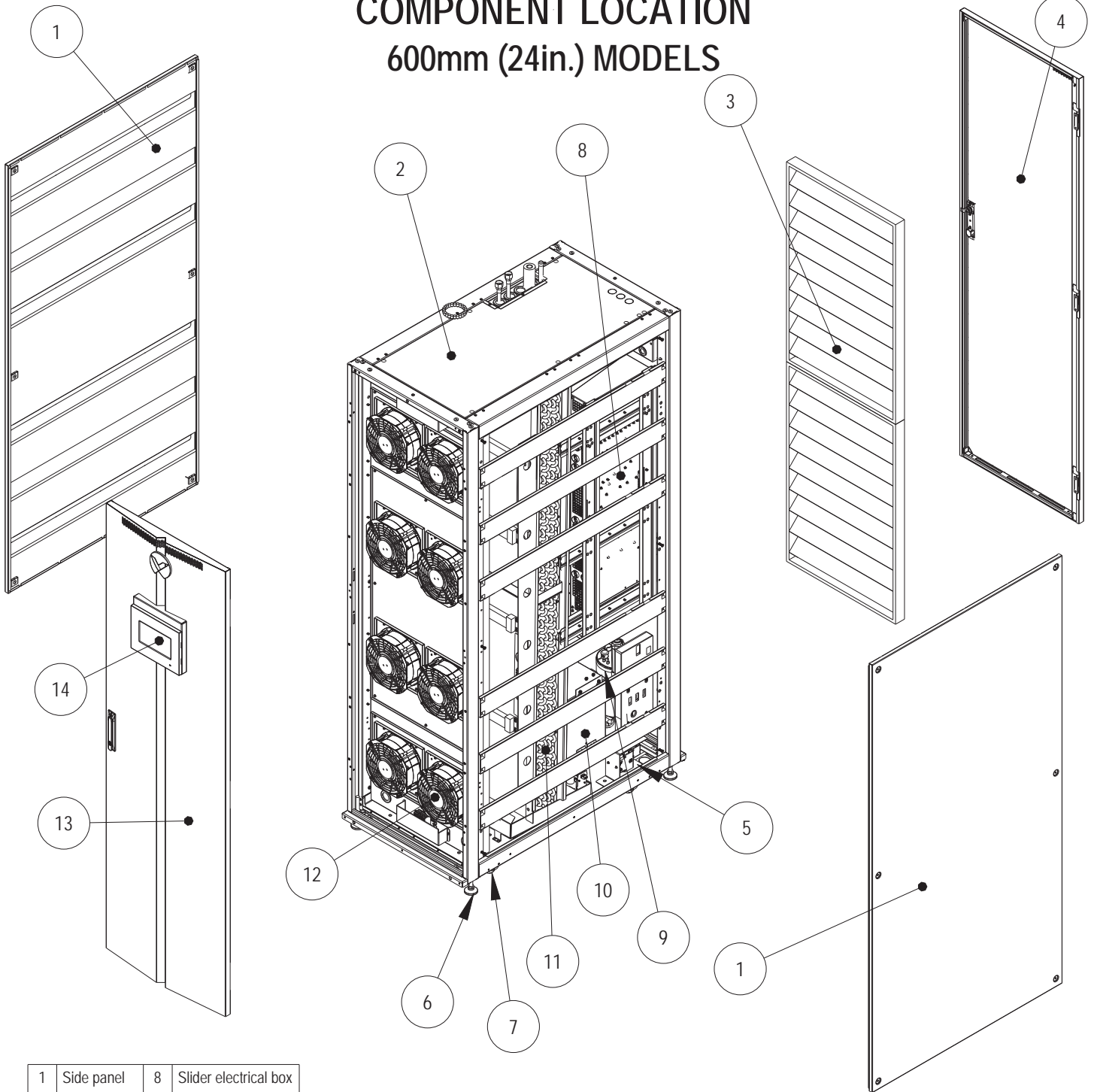

1	Side panel	8	Slider electrical box
2	Top panel	9	Humidifier (optional)
3	Filter	10	Transformer
4	Rear door	11	Heat exchanger
5	Bottom panel	12	EC fans
6	Leveling feet	13	Front door
7	Casters	14	iCOM display

COMPONENT LOCATION 300mm (12in.) MODELS

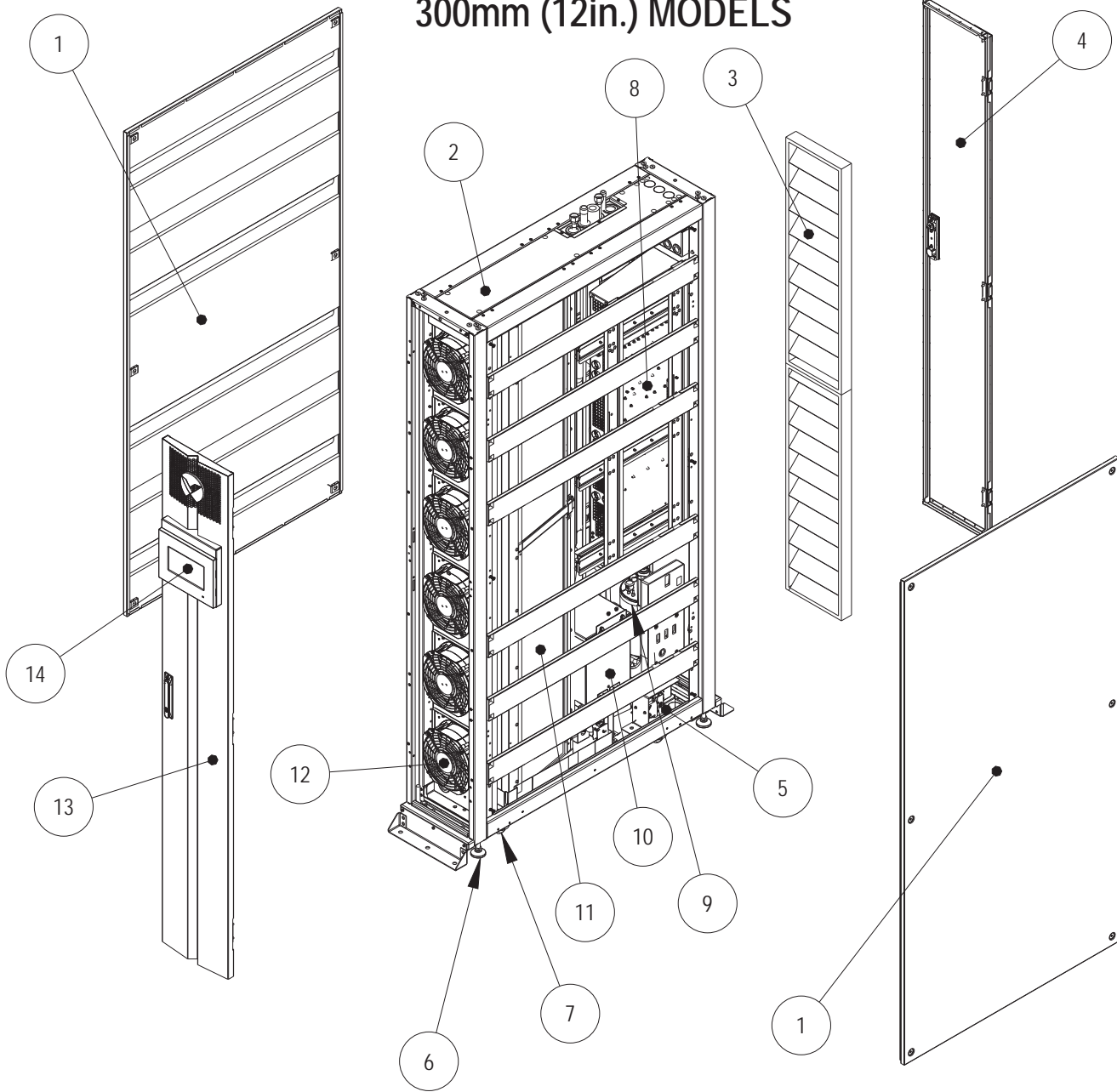

1	Side panel	8	Slider electrical box
2	Top panel	9	Humidifier (optional)
3	Filter	10	Transformer
4	Rear door	11	Heat exchanger
5	Bottom panel	12	EC fans
6	Leveling feet	13	Front door
7	Casters	14	iCOM display

VERTIV COOLPHASE ROW

CABINET DIMENSIONAL DATA

600mm (24in.) MODELS

ACCESS REQUIRED FOR SERVICE THE UNIT
WITHIN THE ROW

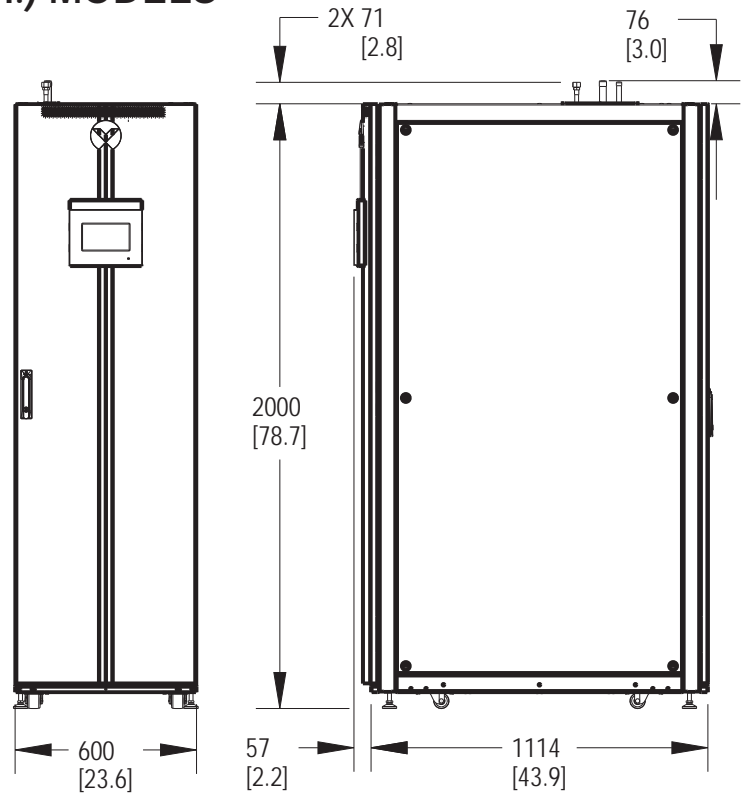
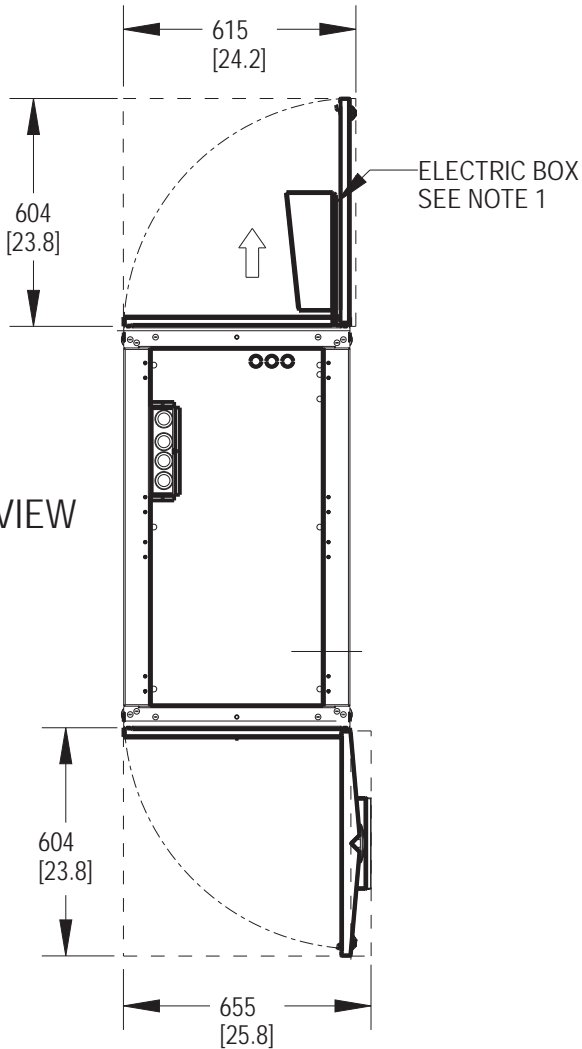

Cooling System	Dry Weight, +/- 5% lbs (kg)
AIR	703 (319)

NOTES:

1. ELECTRIC BOX IS IN REAR OF UNIT (SHOWN FULLY EXTENDED). FOR SERVICE ACCESS TO ELECTRIC BOX REMOVE REAR DOOR. SLIDE ELECTRIC BOX REARWARD IN DIRECTION OF ARROW. ELECTRIC BOX DOOR SWINGS OPEN AS SHOWN. REAR EDGE OF UNIT MUST BE FLUSH WITH ADJACENT CABINET WITH REAR DOOR INSTALLED.

ACCESS REQUIRED FOR INSTALLATION

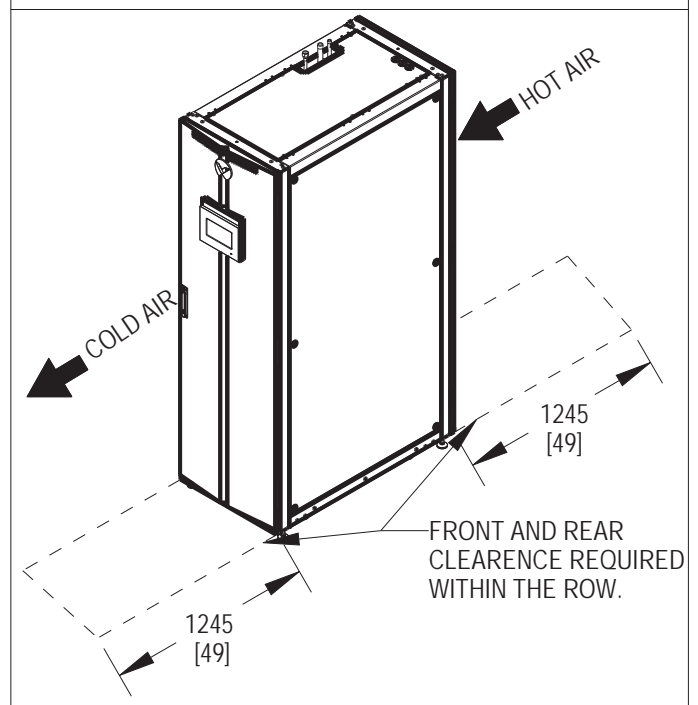



VERTIV COOLPHASE ROW

CABINET DIMENSIONAL DATA

300mm (12in.) MODELS

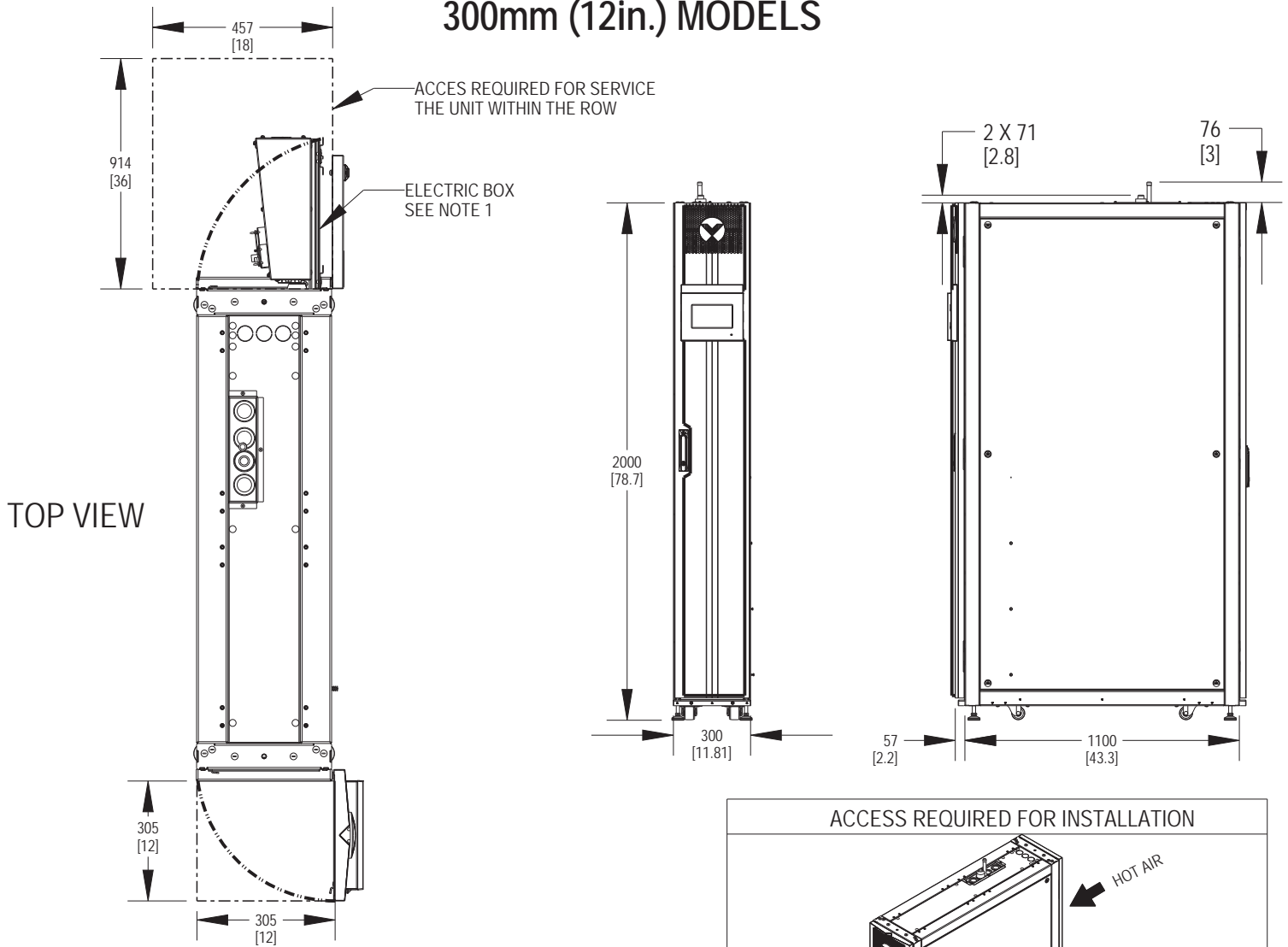

Cooling System	Dry Weight, +/- 5% lbs (kg)
AIR	507 (230)

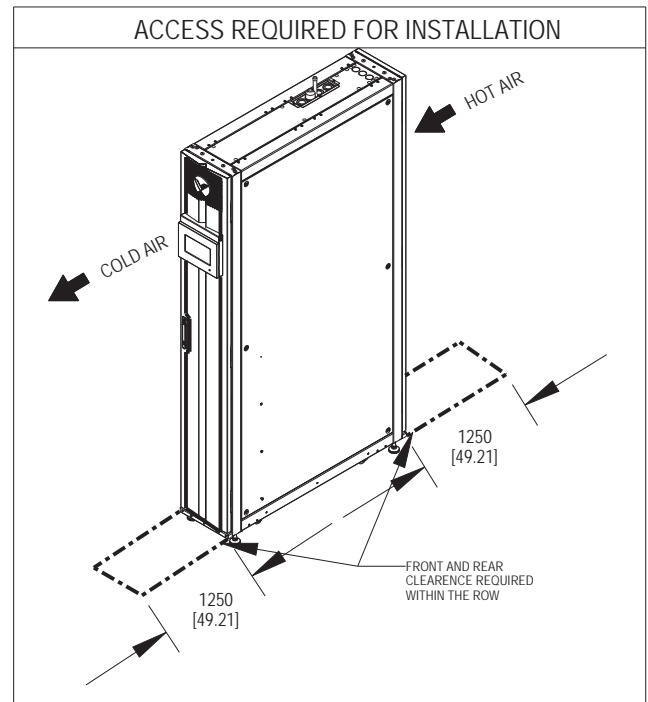

NOTES:

1. ELECTRIC BOX IS IN REAR OF UNIT (SHOWN FULLY EXTENDED). FOR SERVICE ACCESS TO ELECTRIC BOX REMOVE REAR DOOR. SLIDE ELECTRIC BOX REARWARD IN DIRECTION OF ARROW. ELECTRIC BOX DOOR SWINGS OPEN AS SHOWN. REAR EDGE OF UNIT MUST BE FLUSH WITH ADJACENT CABINET WITH REAR DOOR INSTALLED.



VERTIV™ VERTIV COOLPHASE ROW 300/600

GENERAL ARRANGEMENT DIAGRAM 300/600 MM (12/24IN) AIR COOLED MODELS

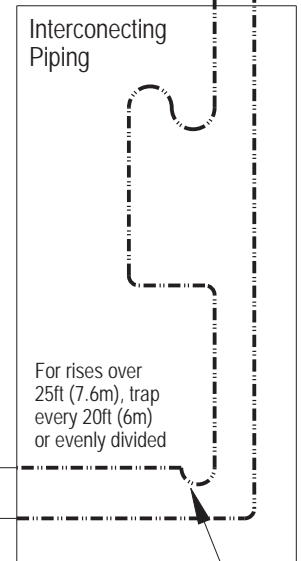
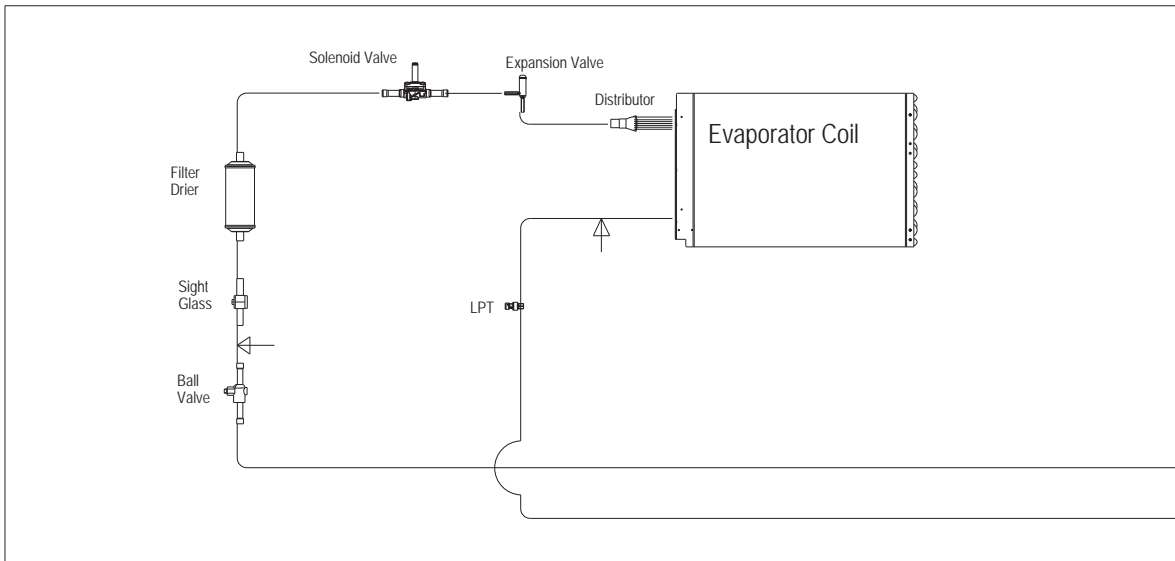
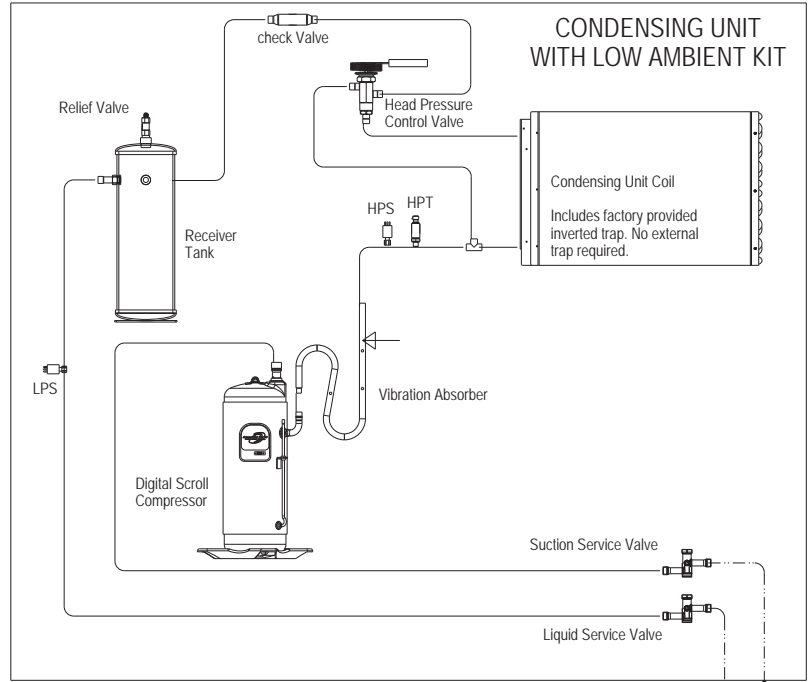
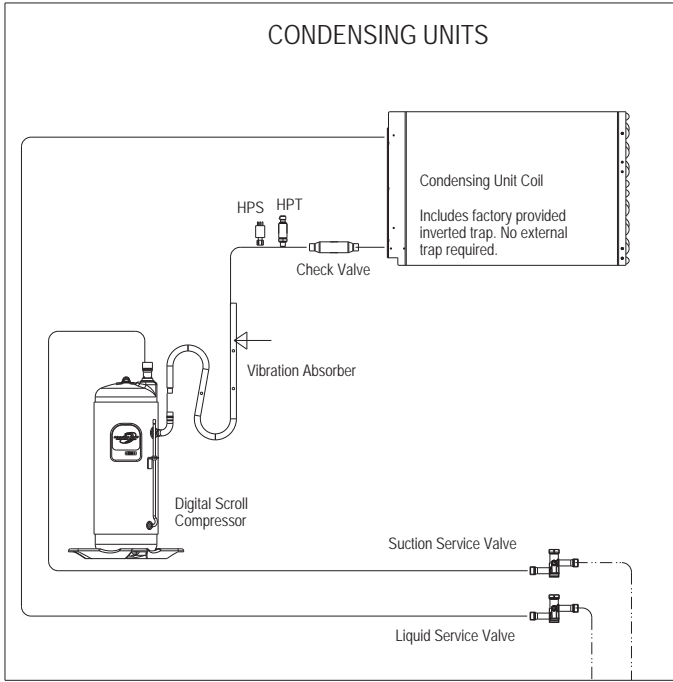

————— FACTORY REFRIGERANT PIPING
- - - - - FIELD PIPING

▽ SERVICE / SCHRADER (ACCESS) CONNECTION NO VALVE CORE
⬇ SERVICE / SCHRADER (ACCESS) CONNECTION WITH VALVE CORE

Trap at base of risers over 5ft. (1.5m)

Notes:

1. Schematic representation shown. Do not use for specific connection locations.
2. Interconnecting Piping are not supplied by Vertiv™, but are required for proper circuit operation and maintenance. Vertiv CoolPhase Row has an internal trap at the base of the unit. For field piping the discharge line vertical rise starts at the base of the unit and not the top of the unit.
3. Do not isolate any refrigerant circuit from over pressurization protection.
4. Traps must be installed and horizontal lines pitched to ensure proper oil return and to reduce liquid floodback to compressor. Pitch horizontal hot gas piping at a minimum of 1/2" per 10 feet (42mm per 10m) so that gravity will aid in moving oil in the direction of the refrigeration flow.

VERTIV COOLPHASE ROW

Primary Connection Locations 600mm (24in.) Air Cooled Models

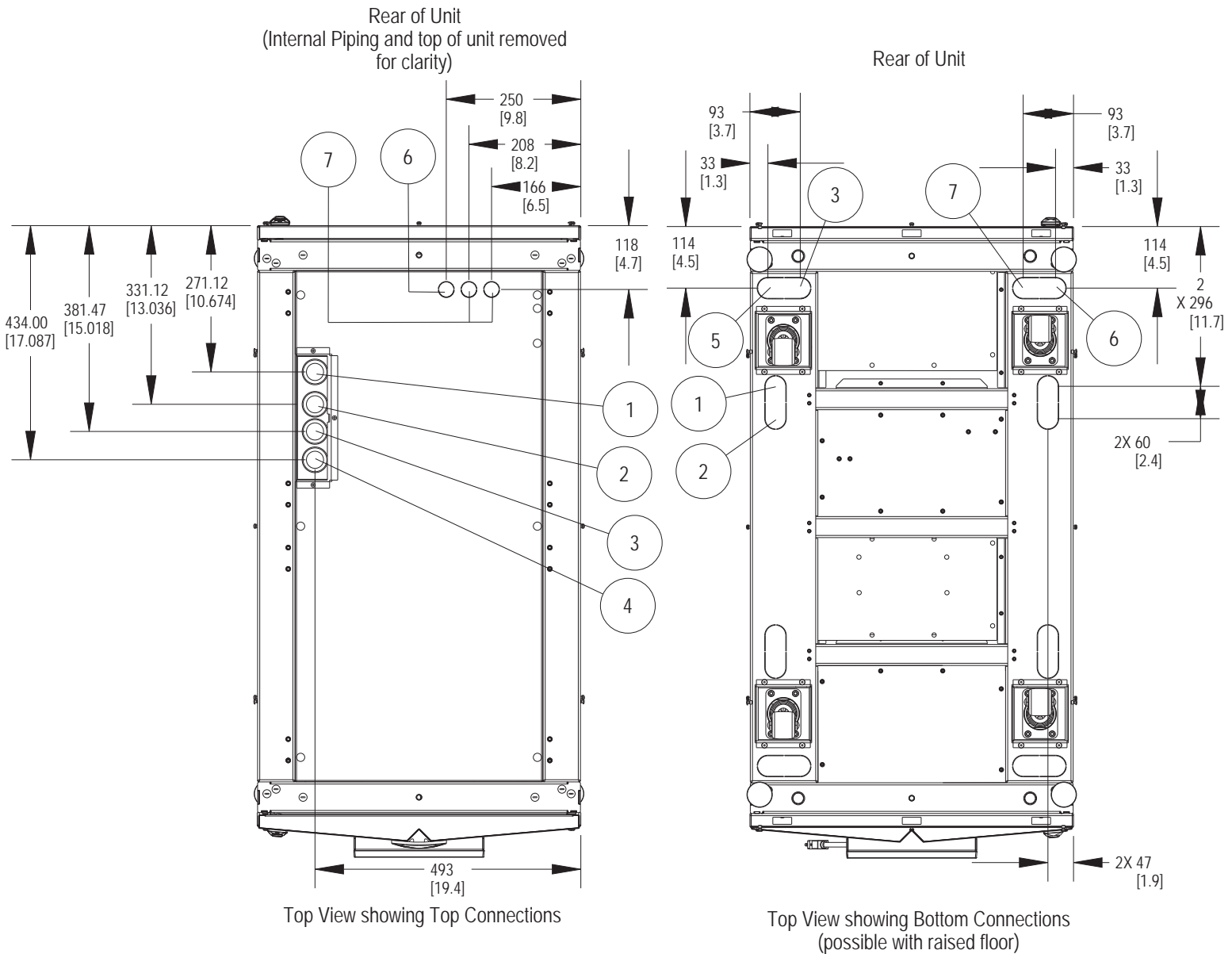

1	RLT	Refrigerant liquid line inlet	5/8 in. O.D. copper sweat
2	RGT	Refrigerant gas line outlet	7/8 in. O.D. copper sweat
3	HF	Humidifier Supply	G 3/4 x Rc 1/2 in.
4	CPT	Condensate pump outlet	Rc 1/2 in. female copper, threaded joint
5	CGT	Condensate gravity outlet	Rc 1/2 in. female copper threaded joint
6	HVT	High Voltage Cable access	Combination knockout: 28 mm (1-1/8 in.)
7	LVT	Low Voltage cable access	Combination knockout: 22 mm (7/8 in.)
NOTE: All dimensions are in mm (in.).			

PIPING AND ELECTRICAL CONNECTIONS AVAILABLE AT THE TOP AND BOTTOM OF UNIT.
ATTENTION, AIR COOLED SYSTEMS MAY REQUIRE ADDITIONAL OIL TO BE ADDED IN THE FIELD IN ORDER TO ALLOW FOR SUFFICIENT COMPRESSOR LUBRICATION. SEE UNIT USER MANUAL FOR DETAILS.

VERTIV COOLPHASE ROW

Primary Connection Locations 300mm (12in.) Air Cooled Models

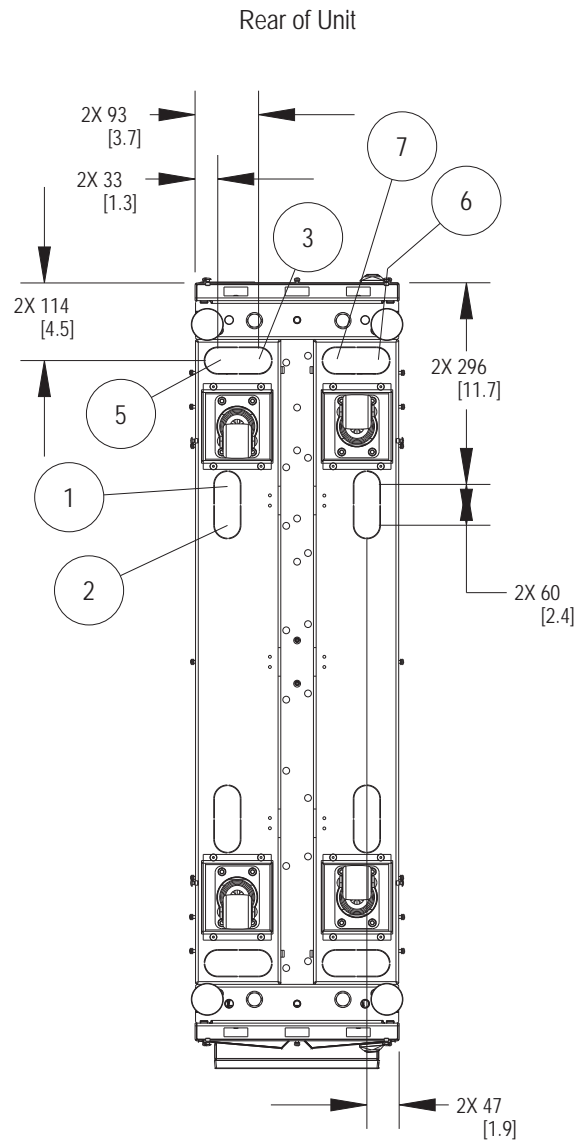
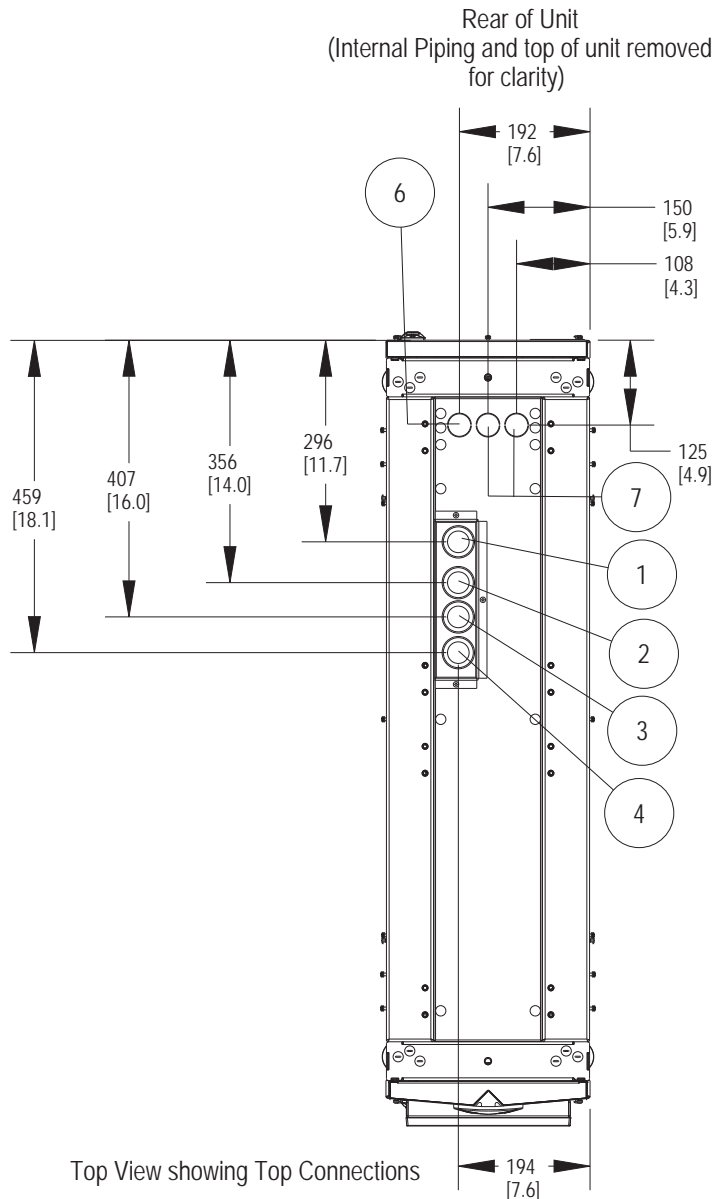

1	RLT	Refrigerant liquid line inlet	5/8 in. O.D. copper sweat
2	RGT	Refrigerant gas line outlet	7/8 in. O.D. copper sweat
3	HF	Humidifier Supply	G 3/4 x Rc 1/2 in.
4	CPT	Condensate pump outlet	Rc 1/2 in. female copper, threaded joint
5	CGT	Condensate gravity outlet	Rc 1/2 in. female copper threaded joint
6	HVT	High Voltage Cable access	Combination knockout: 28 mm (1-1/8 in.)
7	LVT	Low Voltage cable access	Combination knockout: 22 mm (7/8 in.)

NOTE: All dimensions are in mm (in.).

PIPING AND ELECTRICAL CONNECTIONS AVAILABLE AT THE TOP AND BOTTOM OF UNIT.
ATTENTION, AIR COOLED SYSTEMS MAY REQUIRE ADDITIONAL OIL TO BE ADDED IN THE FIELD IN ORDER TO ALLOW FOR SUFFICIENT COMPRESSOR LUBRICATION. SEE UNIT USER MANUAL FOR DETAILS.



VERTIV. VERTIV COOLPHASE CONDENSING UNIT

PIPING SCHEMATIC CONDENSING UNIT ABOVE INDOOR UNIT 21 & 28kW

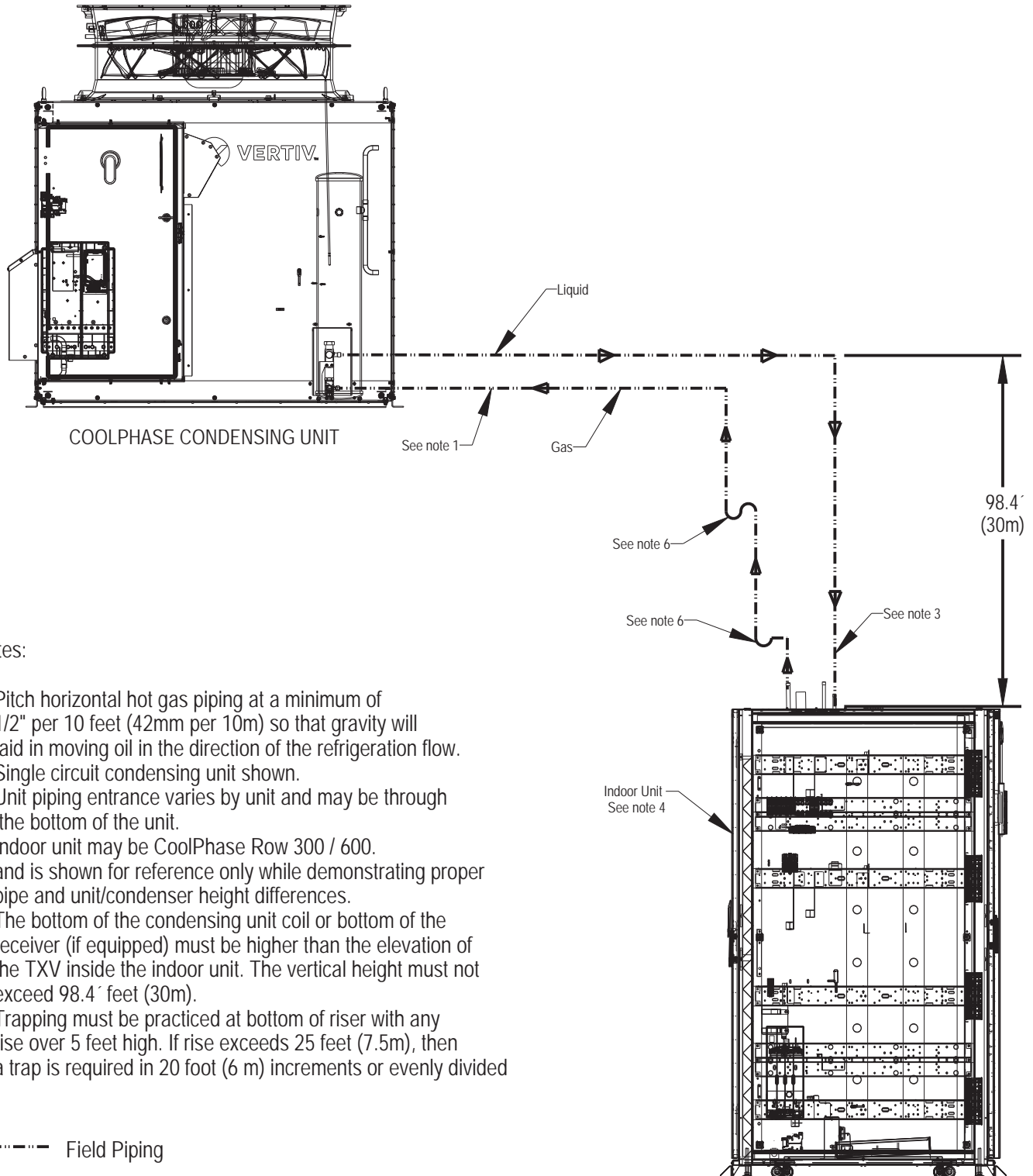

Notes:

1. Pitch horizontal hot gas piping at a minimum of 1/2" per 10 feet (42mm per 10m) so that gravity will aid in moving oil in the direction of the refrigeration flow.
2. Single circuit condensing unit shown.
3. Unit piping entrance varies by unit and may be through the bottom of the unit.
4. Indoor unit may be CoolPhase Row 300 / 600 and is shown for reference only while demonstrating proper pipe and unit/condenser height differences.
5. The bottom of the condensing unit coil or bottom of the receiver (if equipped) must be higher than the elevation of the TXV inside the indoor unit. The vertical height must not exceed 98.4 feet (30m).
6. Trapping must be practiced at bottom of riser with any rise over 5 feet high. If rise exceeds 25 feet (7.5m), then a trap is required in 20 foot (6 m) increments or evenly divided



VERTIV. VERTIV COOLPHASE CONDENSING UNIT

PIPING SCHEMATIC

CONDENSING UNIT BELOW INDOOR UNIT 21 & 28kW

Notes:

1. Pitch horizontal hot gas piping at a minimum of 1/2" per 10 feet (42mm per 10m) so that gravity will aid in moving oil in the direction of the refrigeration flow.
2. Single circuit condensing unit shown.
3. Unit piping entrance varies by unit and may be through the top of the unit.
4. Indoor unit may be Vertiv CoolPhase Row 300 / 600 and is shown for reference only while demonstrating proper pipe and unit/condenser height differences.

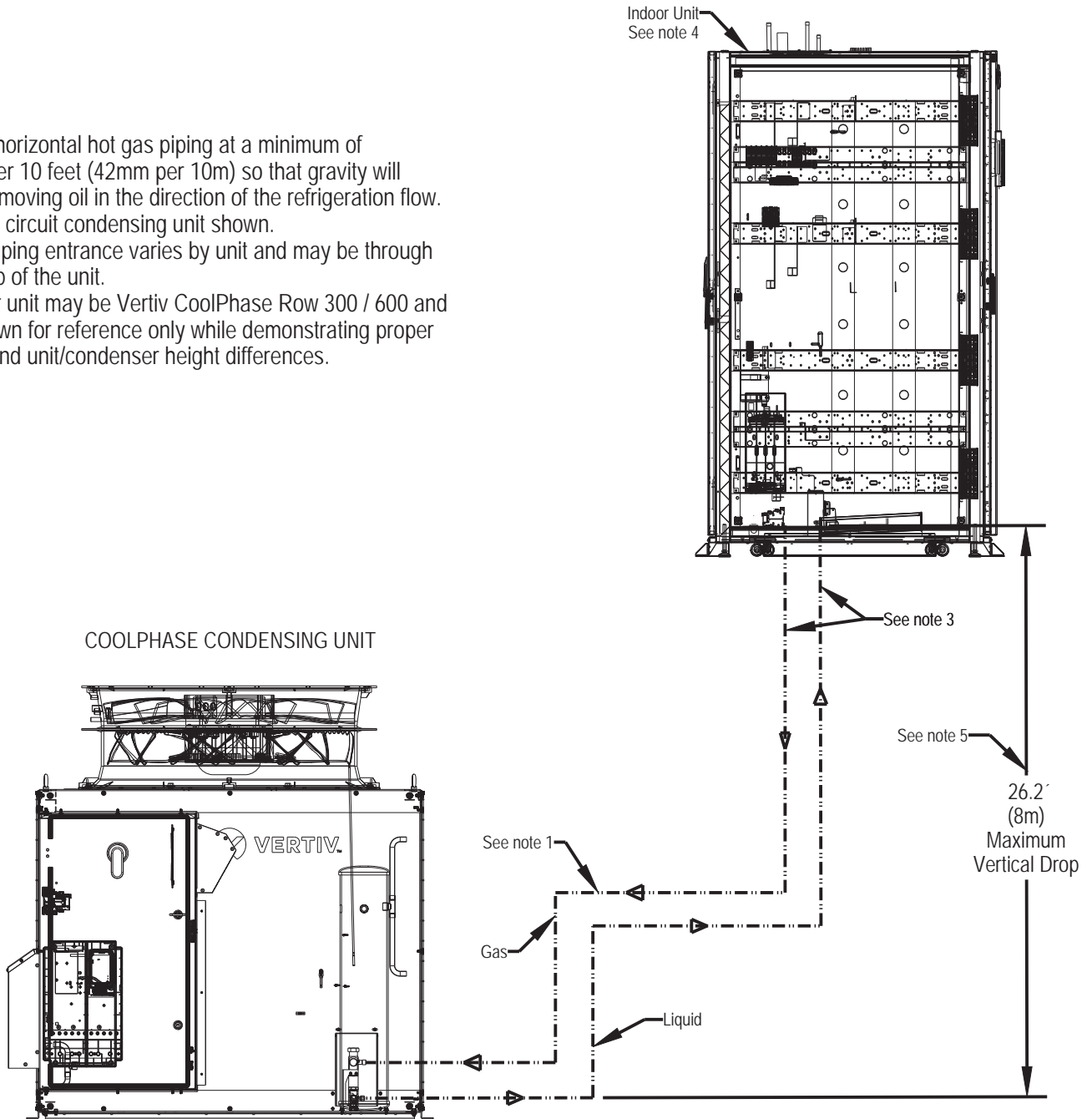

----- Field Piping



COOLPHASE ROW

ELECTRICAL FIELD CONNECTIONS & TERMINAL BLOCKS CONNECTIONS

STANDARD ELECTRICAL CONNECTIONS

- 1) **High Voltage connection through the top of the CoolPhase Row** - 1.37" (35mm) diameter concentric knockout.
- 2) **Communication connection through the top of the CoolPhase Row** - 1.37" (35mm) diameter concentric knockout. connect according diagram in the corresponding ethernet port.
- 3) **Electrical service (hard wired)** - refer to serial tag information for unit electrical service requirement

- **Three Phase - 208-230V 60HZ / 460 60HZ**
- **Single Phase - 208-230V 60HZ**

Connect to terminals on disconnect switch. Electrical service not by Vertiv. Use copper conductors only, Wire per local codes. Refer to specification sheet for total unit full load amps, wire size amps and max over current protection device size.

4) Main Power Box

- Factory Installed Disconnect Switch.
- TBK 37-2 and 38-2 Remote Shut Down terminals prepared to customer connections.
- TBK 24-2 and 51-2 Water Under Flow Option prepared to customer connections.
- TBK 75-2 and 76-2 Common Alarm Option prepared to customer connections.

5) Communication Bracket

- Z1 Can communication 1 Connect ICOM2 P74 (Embedded Unity Card Port).
- Z2 (Not Used)
- Z3 TEAMWORK Connect ICOM2 P64.
- Z4 Modbus (RS485) Communication for outdoor unit.

6) Terminal Blocks Control Distribution Voltage / Power Voltage Terminals / Communication RS485

- TBK L1 - L2 - L3 Transformer Connection only for 460VAC Units (X1-X4).
- TBK PE Terminal Ground.
- TBK 242 and G2 Control Distribution Voltage 24VAC 242 (L) G2 (N).
- TBK-G1 and TBK 241 Control Distribution Voltage 24VAC Insulated Voltage from Transformer 1:1.
- TBK A and TBK B RS485 Communication Distribution Terminal Blocks.
- TBK-92 and TBK-93 Control Voltage to activate the Reheat Relay.

7) Fans Terminal Blocks

- TBK 48V 48VDC + Distribution.
- TBK GND 48VDC - Distribution.
- TBK- FCTR Fan Control Signal 0-10V Distribution.

Reference models showed in this document are 300MM units. All connections, terminal block locations and communication ports also apply for 600MM units.

COOLPHASE ROW

ELECTRICAL FIELD CONNECTIONS & TERMINAL BLOCKS CONNECTIONS

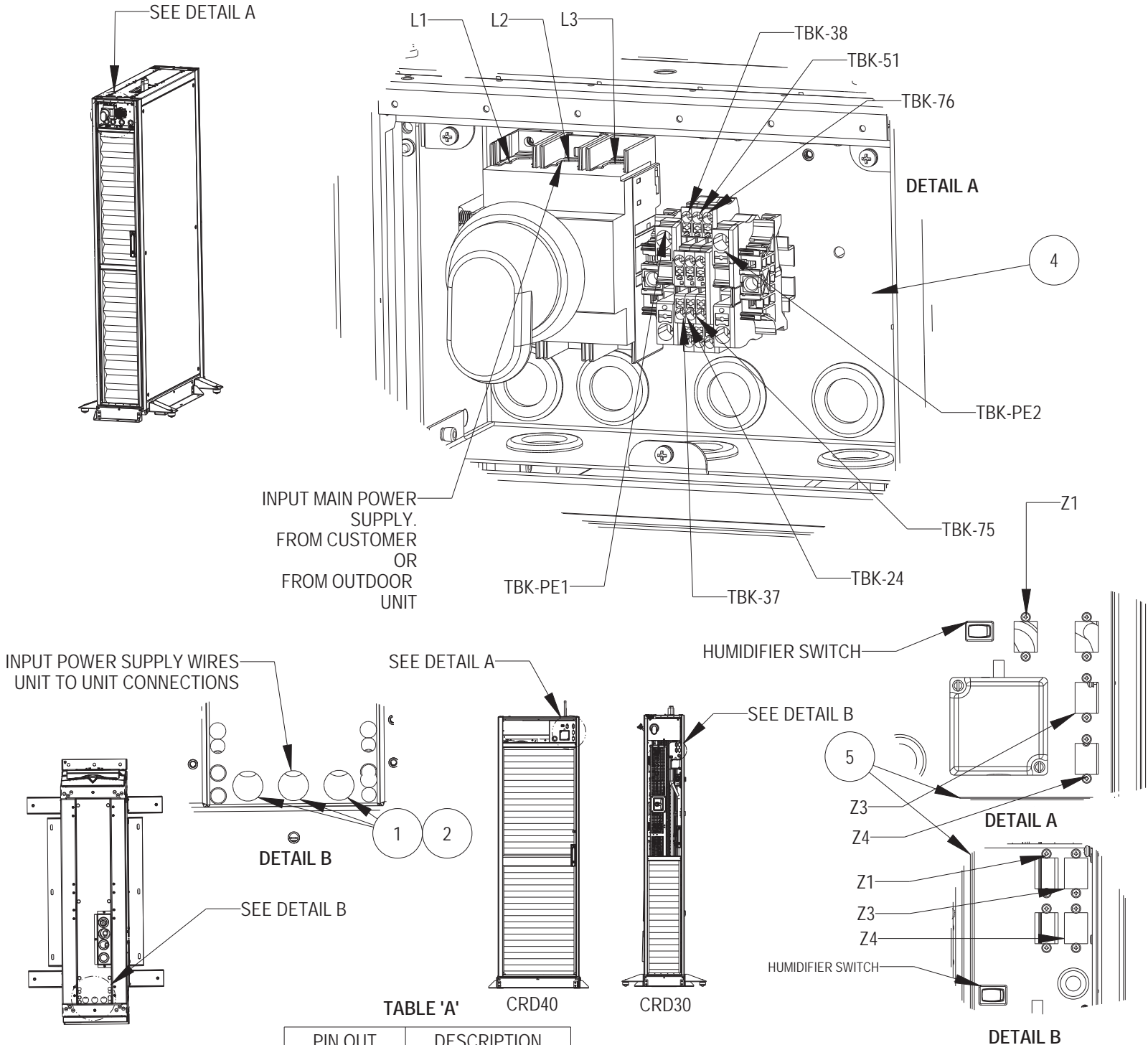

PIN OUT	DESCRIPTION
Z4-1 / Z4-8	MODBUS A / B
Z4-3/Z4-4	24VAC L / 24VAC N

ETHERNET CABLE CONFIGURATION MUST BE STRAIGHT CONFIGURATION.
Z4 PIN OUT (INDOOR - OUTDOOR COMMUNICATION) SEE TABLE 'A'

COOLPHASE ROW

ELECTRICAL FIELD CONNECTIONS & TERMINAL BLOCKS CONNECTIONS

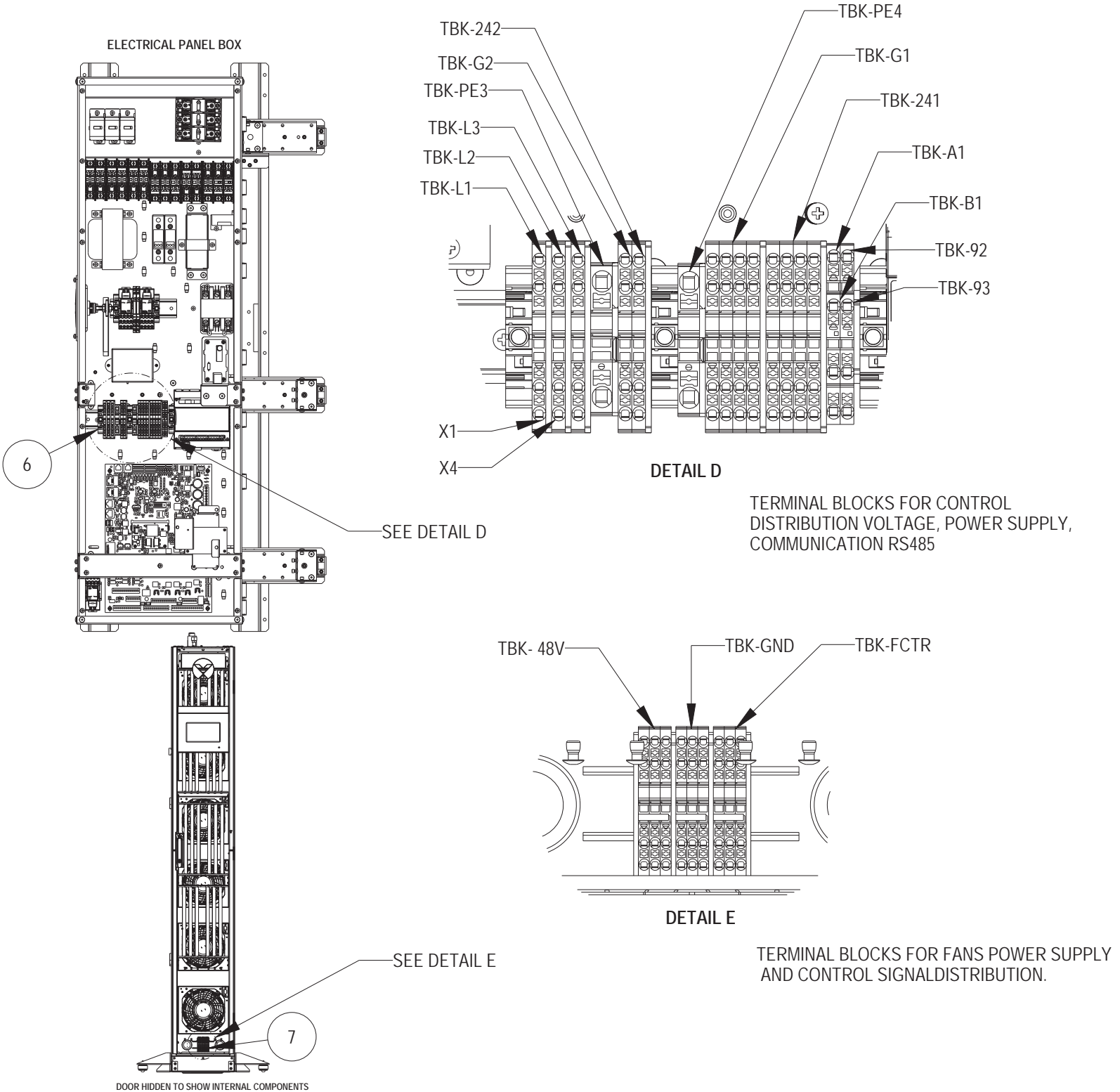

VERTIV COOLPHASE ROW

DIMENSIONAL DATA

600mm (24in.) RIGID FLOOR MOUNT BRACKET

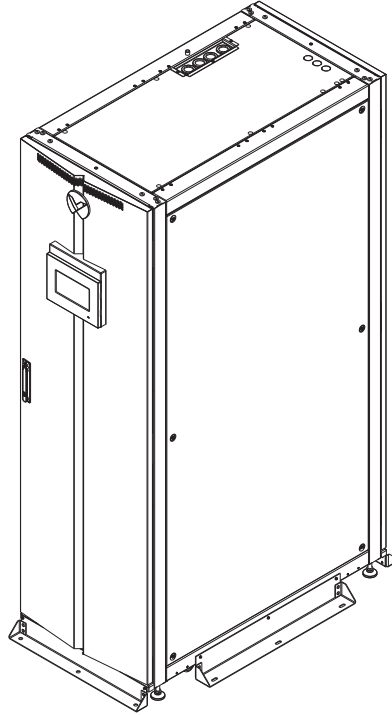

ISO VIEW ON FLOOR

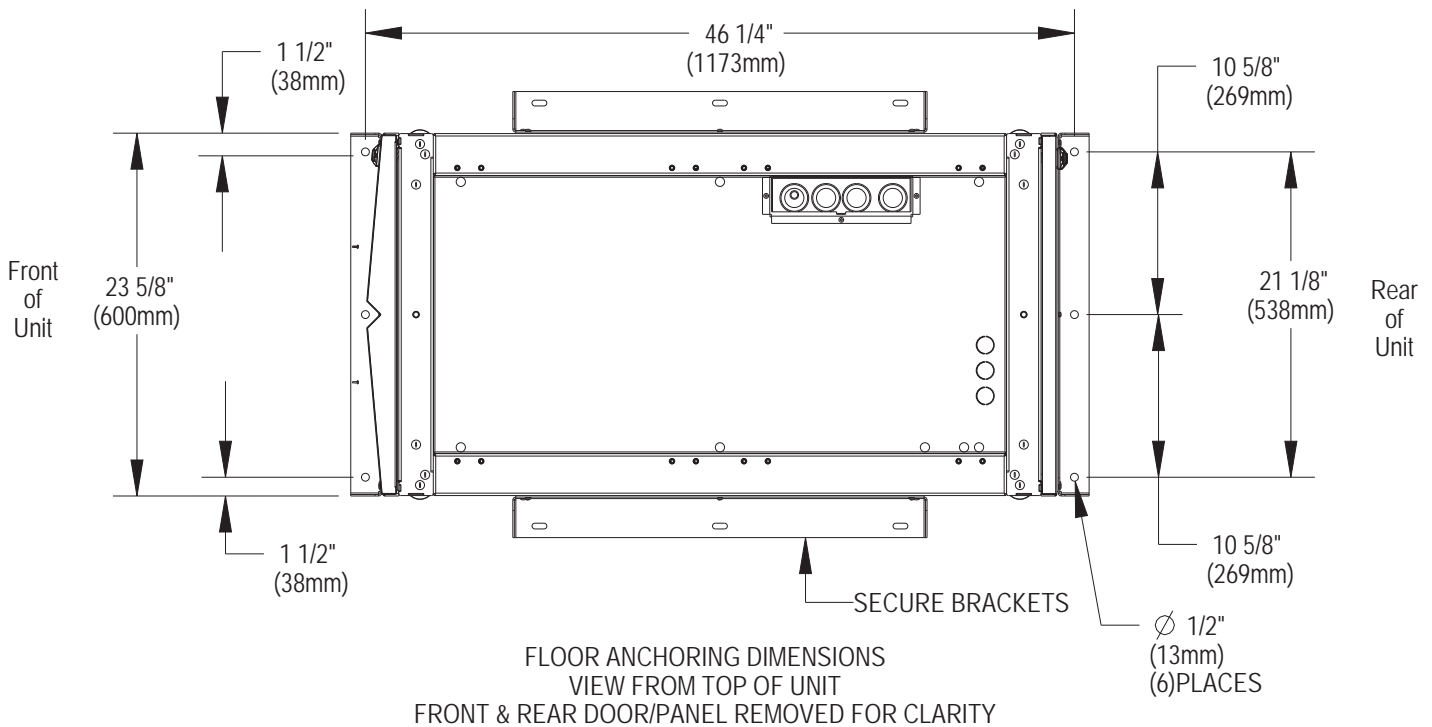

DIMENSIONAL DATA

600mm (24in.) RIGID FLOOR MOUNT BRACKET

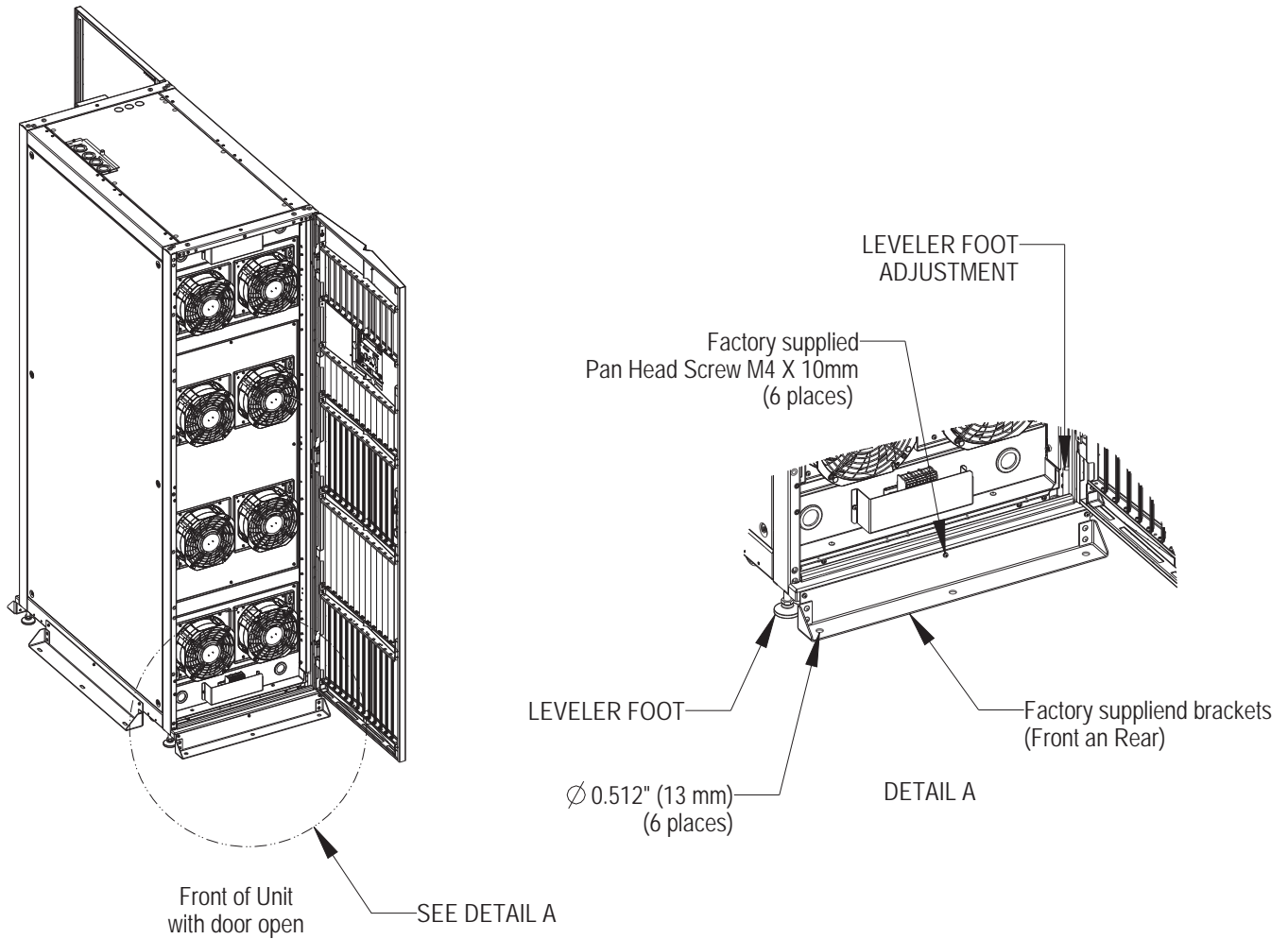

Notes:

1. Prior to mounting brackets, lower the four leveling feet (See Detail "A") until they make contact with the floor. Ensure that the unit is level to avoid corrosion or health hazards caused by condensate accumulation.
2. Anchor the brackets to the unit using the screws that are provided.
3. The brackets are to be secured to the floor using field supplied anchors.
4. The same mounting brackets are used in the front and rear of the unit.
5. This document is not to be used for field installation, see Vertiv™ CoolPhase Row User Manual.

VERTIV COOLPHASE ROW

DIMENSIONAL DATA

300mm (12in) RIGID FLOOR MOUNT BRACKET

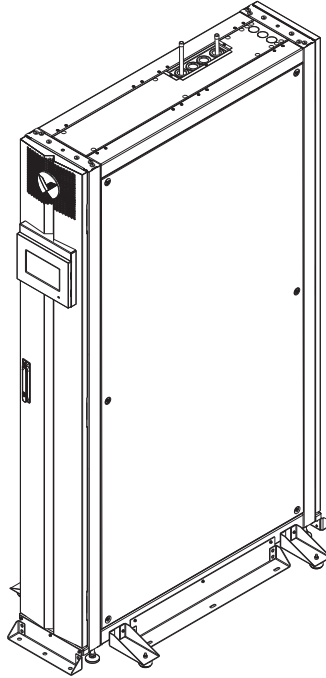

ISO VIEW ON FLOOR

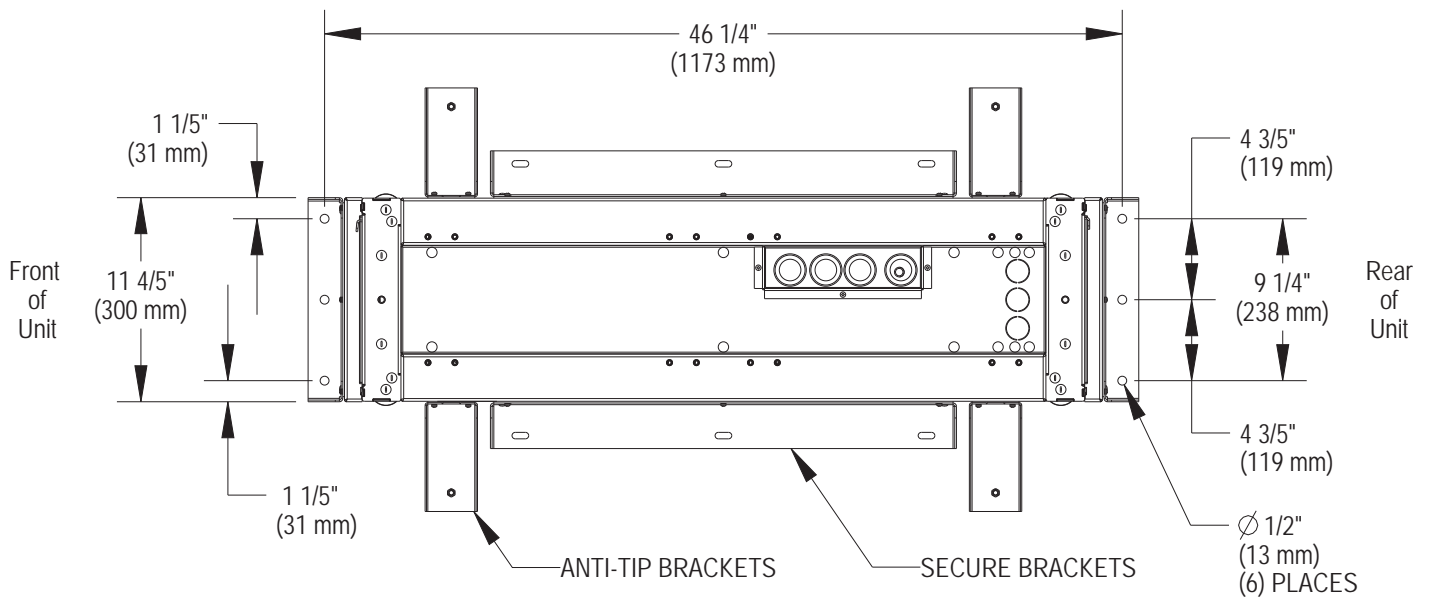

FLOOR ANCHORING DIMENSIONS

VIEW FROM TOP OF UNIT
FRONT & REAR DOOR/PANEL REMOVED FOR CLARITY

DIMENSIONAL DATA

300mm (12in) RIGID FLOOR MOUNT BRACKET

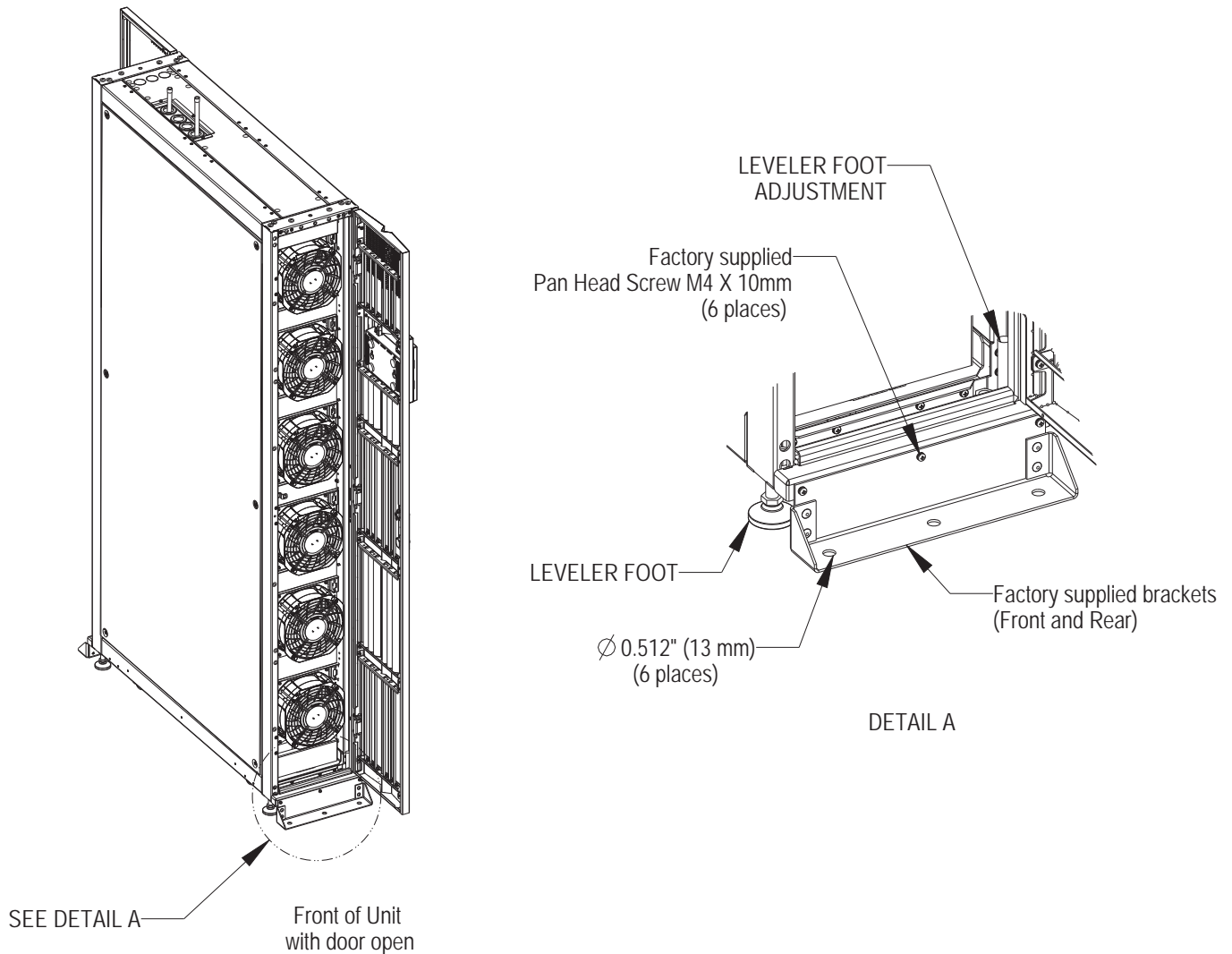

Notes:

1. Prior to mounting brackets, lower the four leveling feet (See Detail "A") until they make contact with the floor. Ensure that the unit is level to avoid corrosion or health hazards caused by condensate accumulation.
2. Anchor the brackets to the unit using the screws that are provided.
3. The brackets are to be secured to the floor using field supplied anchors.
4. The same mounting brackets are used in the front and rear of the unit.
5. This document is not to be used for field installation, see Vertiv™ CoolPhase Row User Manual.

LINE VOLTAGE
3 PHASE SUPPLY (A)

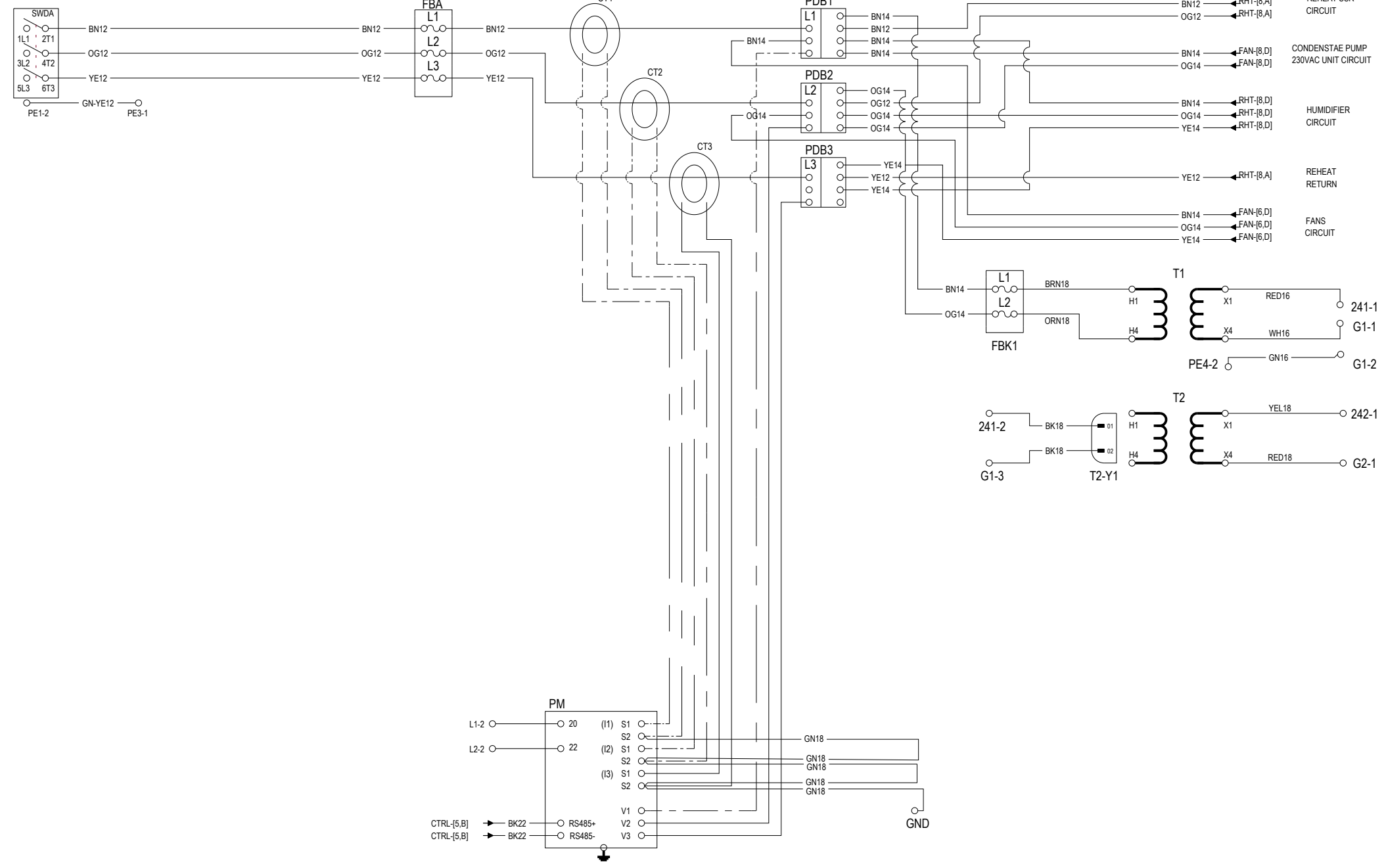

- NOTES:
1. ALL FIELD WIRING TO BE PER LOCAL CODES. USE COPPER CONDUCTORS ONLY.
 2. SEE INSTALLATION AND USER MANUAL(S).
 3. JUMPER TO BE REMOVED WHEN OPTIONAL COMPONENT IS USED.
 4. ALL RJ45/ETHERNET CABLES MUST BE STRAIGHT THROUGH.
 5. 10 DI CARD INSTALLED ON THE FAN PANEL.

NOMENCLATURE			
STANDARD DEVICES	COORD	OPTIONAL DEVICES	COORD
FBA - FUSE BLOCK A	6,D	CT1 - CURRENT TRANSFORMER 1	5,D
FBB - FUSE BLOCK B	6,D	CT2 - CURRENT TRANSFORMER 2	5,D
FBK1 - FUSE BLOCK 1 CONTROL	4,C	CT3 - CURRENT TRANSFORMER 3	5,D
KAC - CONTACTOR RELAY ATS C	6,C	PM - POWER METER	5,B
KAD - CONTACTOR RELAY ATS D	6,C		
KMA - CONTACTOR ATS A	6,C		
KMB - CONTACTOR ATS B	5,C		
PDB1 - POWER DIST BLOCK L1	5,D		
PDB2 - POWER DIST BLOCK L2	5,D		
PDB3 - POWER DIST BLOCK L3	5,D		
SWDA - SWITCH DISCONNECT A	8,D		
SWDB - SWITCH DISCONNECT B	8,D		
T1 - CONTROL TRANSFORMER	3,C		
T2 - ISOLATION TRANSFORMER	3,C		

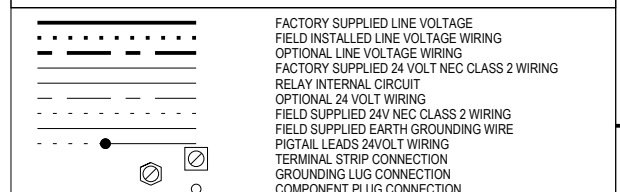

WIRE COLOUR CODE		
OG - ORANGE	PR - PURPLE	BL - BLUE
RD - RED	GR - GREEN	BK - BLACK
BN - BROWN	YEL - YELLOW	WH - WHITE

1650 DEARBORN DRIVE, P.O. BOX 29186
COLUMBUS, OHIO 43229

CAGE CODE
1EDC2

©VERTIV CO.-CONFIDENTIAL AND PROPRIETARY - ALL RIGHTS RESERVED
THIS DOCUMENT (AND THE INFORMATION IT CONTAINS) ARE THE PROPERTY OF VERTIV CO. BY ACCEPTING IT INTO YOUR POSSESSION, YOU AGREE THAT YOU WILL KEEP THIS DOCUMENT, AND ALL INFORMATION CONTAINED HEREIN, IN STRICTEST CONFIDENCE, AND WILL NOT COPY, RE TRANSMIT, USE (EXPECT SOLELY FOR THE BENEFIT OF VERTIV CO.), SELL, LEND OR OTHERWISE DISPOSE OF THE SAME, DIRECTLY OR INDIRECTLY, WITHOUT THE EXPRESS WRITTEN PERMISSION OF VERTIV CO., AND THIS DOCUMENT SHALL BE RETURNED TO VERTIV CO. IMMEDIATELY UPON REQUEST.

VERTIV

ELECTRICAL SCHEMATIC
VERTIV® CRV DX 40kW
460V 3PH 50-60HZ
iCOM2 LARGE CONTROL
WITH HUMIDIFIER & REHEAT
HMI TOUCH SCREEN

DRAWN P. BELMAREZ	DATE 2026/03/23	DRAWING NO 10080202DRW	REV G
CHECKED A. TORRES	DATE 2026/03/23		
ENGR A. TORRES	DATE 2026/03/23		

POWER SUPPLY

SHEET 1 OF 4

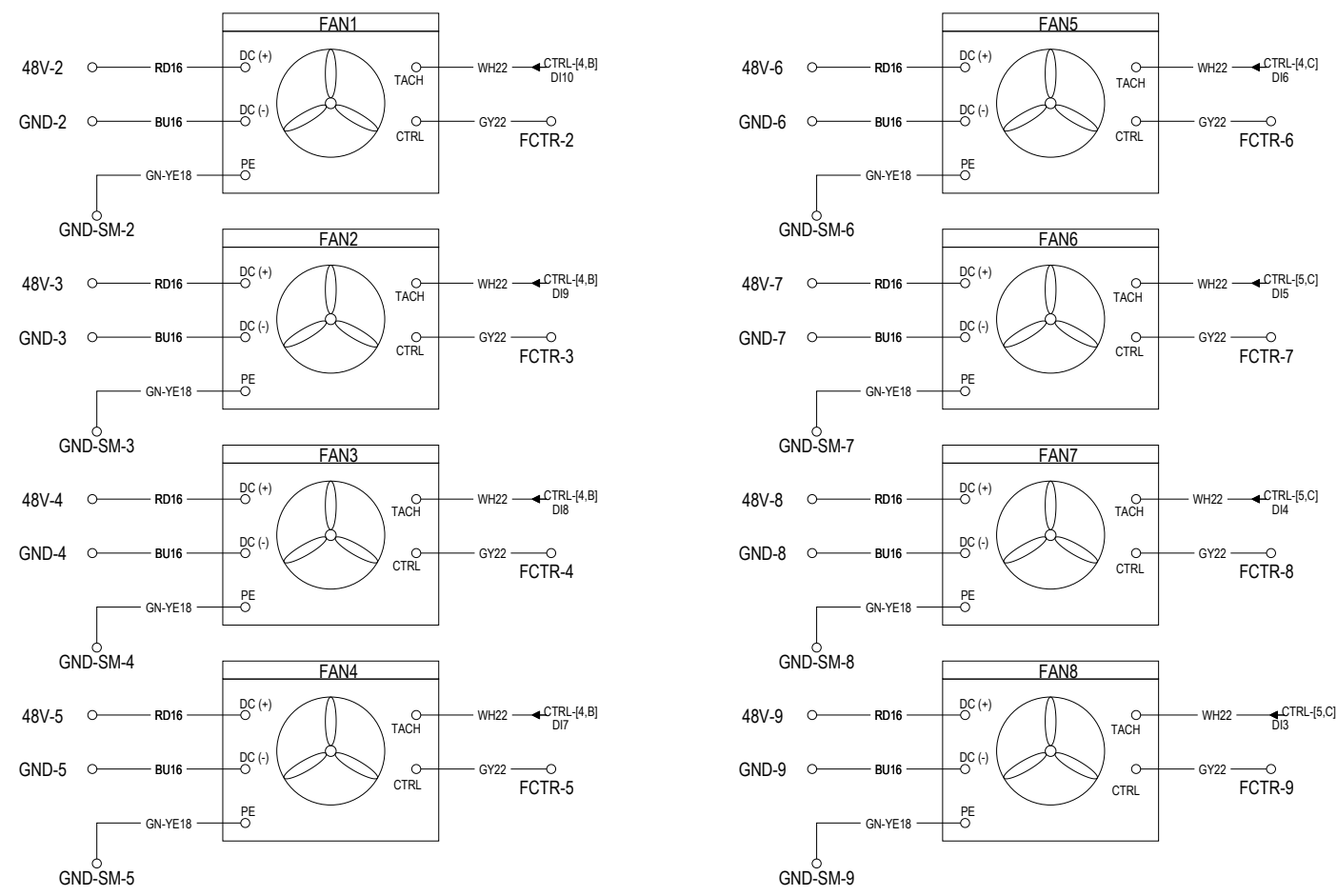
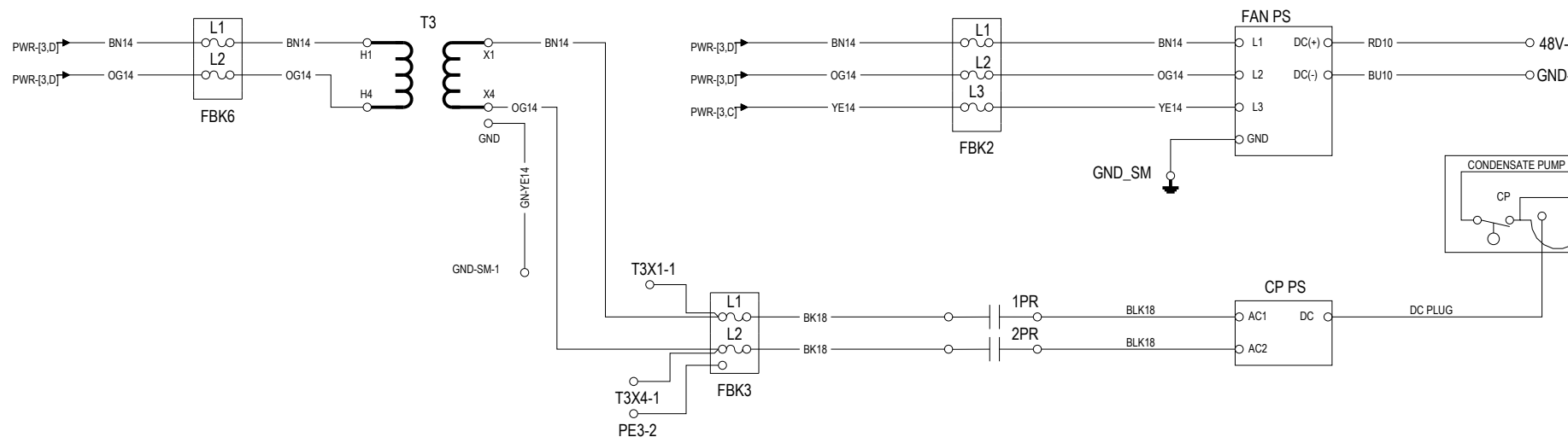

- NOTES:
1. ALL FIELD WIRING TO BE PER LOCAL CODES. USE COPPER CONDUCTORS ONLY.
 2. SEE INSTALLATION AND USER MANUAL(S).
 3. JUMPER TO BE REMOVED WHEN OPTIONAL COMPONENT IS USED.
 4. ALL RJ45/ETHERNET CABLES MUST BE STRAIGHT THROUGH.
 5. 10 DI CARD INSTALLED ON THE FAN PANEL.

NOMENCLATURE			
STANDARD DEVICES	COORD	OPTIONAL DEVICES	COORD
CPPS - CP POWER SUPPLY 24VDC	5.C		
FANPS - FANS POWER SUPPLY 48VDC	5.D		
FBK2 - FUSE BLOCK 2 FANS	6.D		
FBK3 - FUSE BLOCK 3 CP	6.C		
FBK6 - FUSE BLOCK 6 T3	8.D		
T3 - FAN TRANSFORMER	7.D		

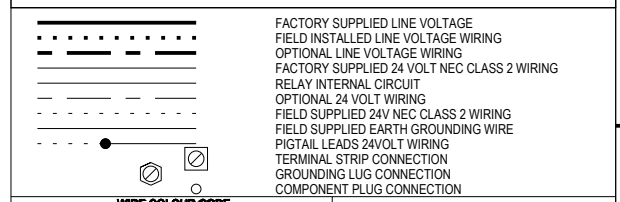

WIRE COLOUR CODE		
OG - ORANGE	PR - PURPLE	BL - BLUE
RD - RED	GR - GREEN	BK - BLACK
BN - BROWN	YEL - YELLOW	WH - WHITE

1650 DEARBORN DRIVE, P.O. BOX 29186
COLUMBUS, OHIO 43229

CAGE CODE
1EDC2

VERTIV CO. - CONFIDENTIAL AND PROPRIETARY - ALL RIGHTS RESERVED
THIS DOCUMENT AND THE INFORMATION IT CONTAINS ARE THE PROPERTY OF VERTIV CO. BY ACCEPTING IT INTO YOUR POSSESSION, YOU AGREE THAT YOU WILL KEEP THIS DOCUMENT, AND ALL INFORMATION CONTAINED HEREIN, IN STRICTEST CONFIDENCE, AND WILL NOT COPY, RE TRANSMIT, USE (EXPECT SOLELY FOR THE BENEFIT OF VERTIV CO.), SELL, LEND OR OTHERWISE DISPOSE OF THE SAME, DIRECTLY OR INDIRECTLY, WITHOUT THE EXPRESS WRITTEN PERMISSION OF VERTIV CO., AND THIS DOCUMENT SHALL BE RETURNED TO VERTIV CO. IMMEDIATELY UPON REQUEST.

VERTIV

ELECTRICAL SCHEMATIC
VERTIV® CRV DX 40kW
460V 3PH 50-60HZ
iCOM2 LARGE CONTROL
WITH HUMIDIFIER & REHEAT
HMI TOUCH SCREEN

DRAWN	P. BELMAREZ	DATE	2026/03/23
CHECKED	A. TORRES	DATE	2026/03/23
ENGR	A. TORRES	DATE	2026/03/23

FANS & CP
SHEET 2 OF 4
DRAWING NO. 10080202DRW
REV G

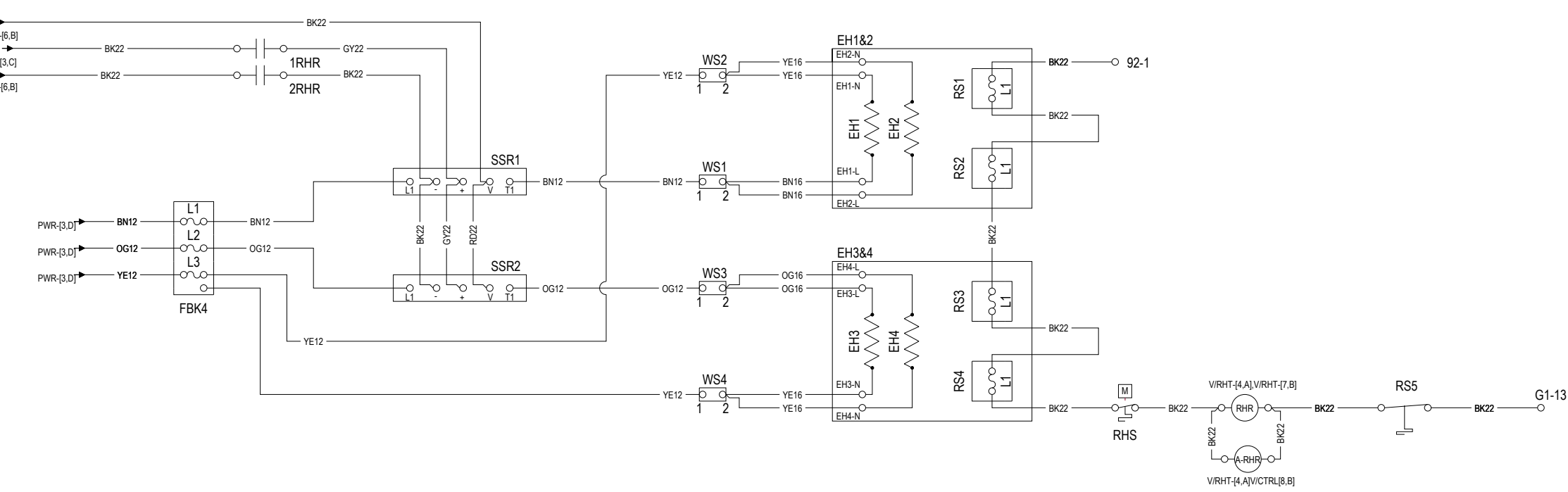
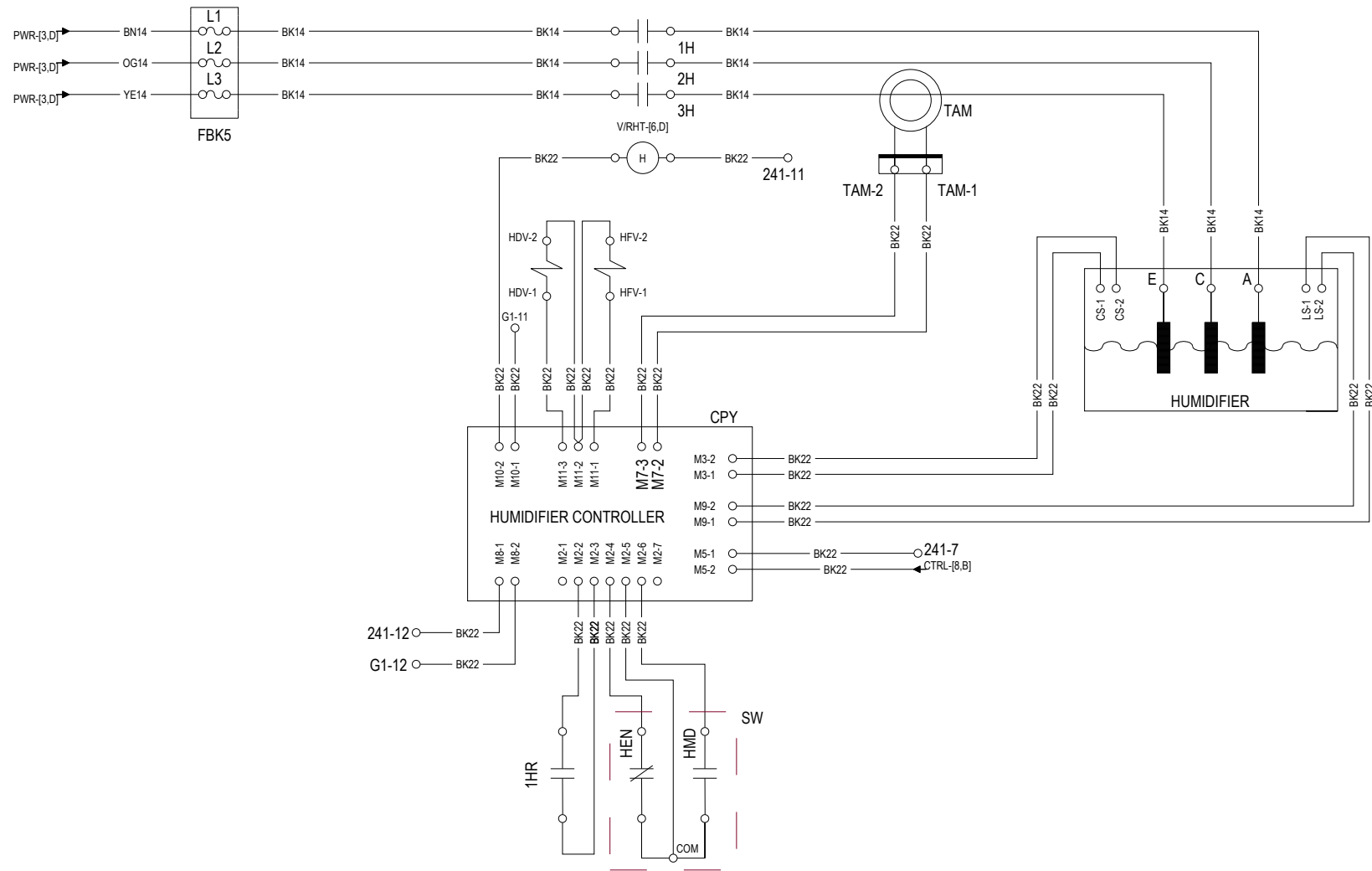

- NOTES:
1. ALL FIELD WIRING TO BE PER LOCAL CODES. USE COPPER CONDUCTORS ONLY.
 2. SEE INSTALLATION AND USER MANUAL(S).
 3. ALL RJ45/ETHERNET CABLES MUST BE STRAIGHT THROUGH.
 4. 10 DI CARD INSTALLED ON THE FAN PANEL.

NOMENCLATURE			
STANDARD DEVICES	COORD	OPTIONAL DEVICES	COORD
EH1-2 - ELECTRICAL REHEAT 1, 2	5,B		
EH3-4 - ELECTRICAL REHEAT 3, 4	5,A		
FBK4 - FUSE BLOCK 4 REHEAT	7,D		
FBK5 - FUSE BLOCK 5 HUMIDIFIER	7,D		
H - HUMIDIFIER CONTACTOR	6,D		
HDV - HUMIDIFIER DRAIN VALVE	6,D		
HFV - HUMIDIFIER FILL VALVE	6,D		
RHR - REHEAT RELAY	7,D		
RS5 - THERMAL CUT-OFF SWITCH	6,D		
SSR1 - SOLID STATE RELAY 1	6,B		
SSR2 - SOLID STATE RELAY 2	6,A		
TAM - HUM CURRENT TRANSFORMER	5,D		
A-RH AUXILIARY CONTACT RHT			
RHS - MANUAL RESET THERMAL CUT-OFF SWITCH	4,D		

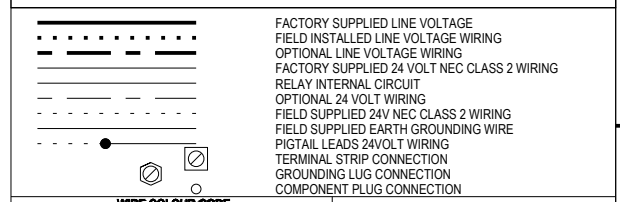

WIRE COLOUR CODE

OG - ORANGE	PR - PURPLE	BL - BLUE
RD - RED	GR - GREEN	BK - BLACK
BN - BROWN	YEL - YELLOW	WH - WHITE



1650 DEARBORN DRIVE, P.O. BOX 29186
COLUMBUS, OHIO 43229

CAGE CODE
1EDC2

©VERTIV CO.-CONFIDENTIAL AND PROPRIETARY - ALL RIGHTS RESERVED
THIS DOCUMENT (AND THE INFORMATION IT CONTAINS) ARE THE PROPERTY OF VERTIV CO. BY ACCEPTING IT INTO YOUR POSSESSION, YOU AGREE THAT YOU WILL KEEP THIS DOCUMENT, AND ALL INFORMATION CONTAINED HEREIN, IN STRICTEST CONFIDENCE, AND WILL NOT COPY, RE TRANSMIT, USE (EXPECT SOLELY FOR THE BENEFIT OF VERTIV CO.), SELL, LEND OR OTHERWISE DISPOSE OF THE SAME, DIRECTLY OR INDIRECTLY, WITHOUT THE EXPRESS WRITTEN PERMISSION OF VERTIV CO., AND THIS DOCUMENT SHALL BE RETURNED TO VERTIV CO. IMMEDIATELY UPON REQUEST.

ELECTRICAL SCHEMATIC
VERTIV® CRV DX 40kW
460V 3PH 50-60HZ
iCOM2 LARGE CONTROL
WITH HUMIDIFIER & REHEAT
HMI TOUCH SCREEN
REHEAT & HUMIDIFIER

DRAWN	P. BELMAREZ	DATE	2026/03/23
CHECKED	A. TORRES	DATE	2026/03/23
ENGR	A. TORRES	DATE	2026/03/23

DRAWING NO	10080202DRW	REV	G
SHEET 4 OF 4			

LINE VOLTAGE
3 PHASE SUPPLY (A)

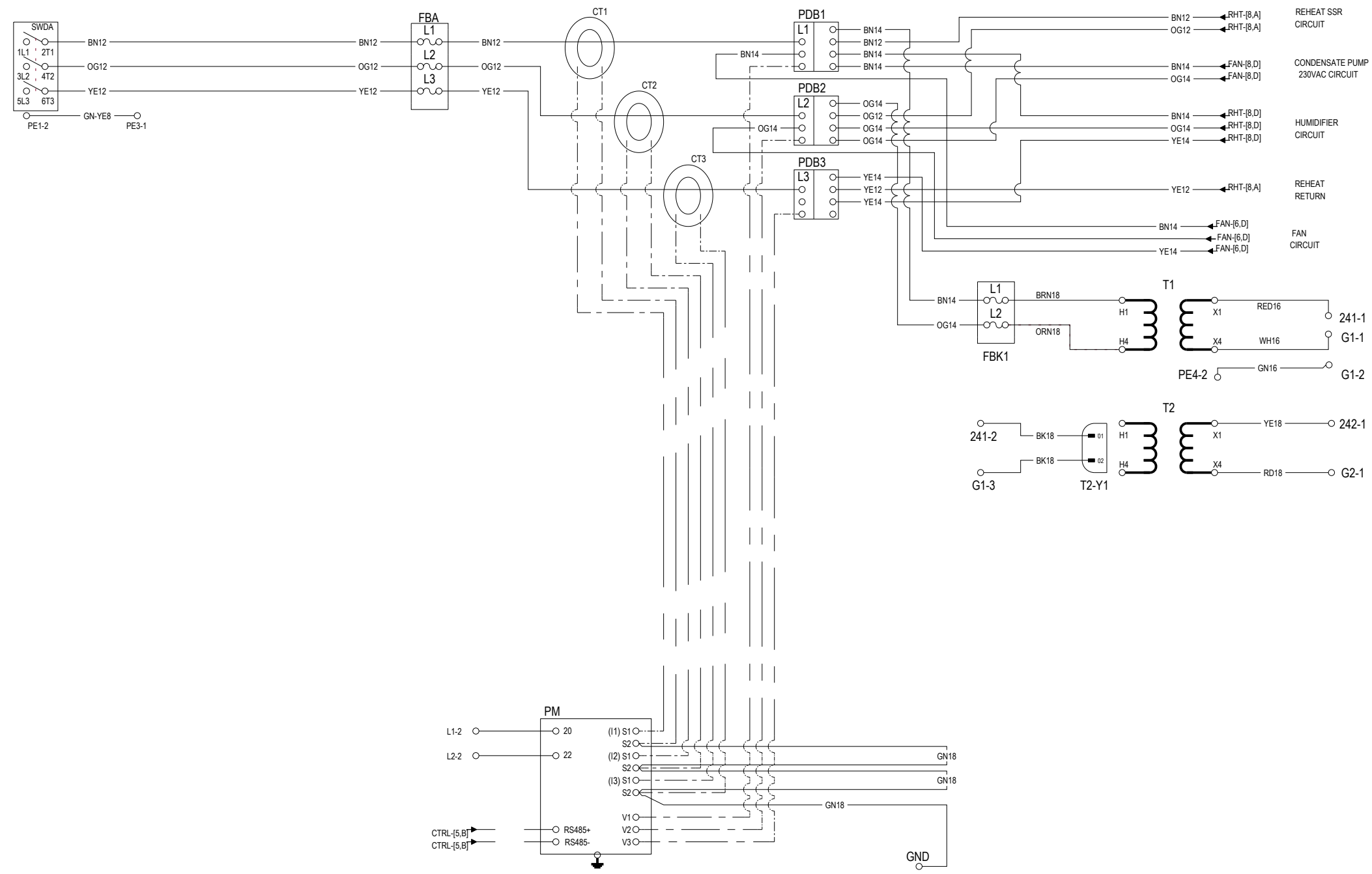

- NOTES:
1. ALL FIELD WIRING TO BE PER LOCAL CODES. USE COPPER CONDUCTORS ONLY.
 2. SEE INSTALLATION AND USER MANUAL(S).
 3. JUMPER TO BE REMOVED WHEN OPTIONAL COMPONENT IS USED.
 4. ALL RJ45/ETHERNET CABLES MUST BE STRAIGHT THROUGH.
 5. 10 DI CARD INSTALLED ON THE FAN PANEL.

NOMENCLATURE			
OPTIONAL DEVICES	COORD	OPTIONAL DEVICES	COORD
FBA - FUSE BLOCK A	6,D	CT1 - CURRENT TRANSFORMER 1	5,D
FBB - FUSE BLOCK B	6,D	CT2 - CURRENT TRANSFORMER 2	5,D
FBK1 - FUSE BLOCK 1 CONTROL	4,C	CT3 - CURRENT TRANSFORMER 3	5,D
KAC - CONTACTOR RELAY ATS C	6,C	PM - POWER METER	5,B
KAD - CONTACTOR RELAY ATS D	6,C		
KMA - CONTACTOR ATS A	6,C		
KMB - CONTACTOR ATS B	5,C		
PDB1 - POWER DIST BLOCK L1	5,D		
PDB2 - POWER DIST BLOCK L2	5,D		
PDB3 - POWER DIST BLOCK L3	5,D		
SWDA - SWITCH DISCONNECT A	8,D		
SWDB - SWITCH DISCONNECT B	8,D		
T1 - CONTROL TRANSFORMER	3,C		
T2 - ISOLATION TRANSFORMER	3,C		

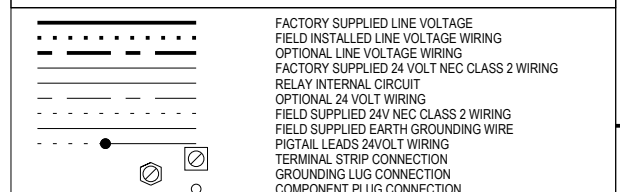

WIRE COLOUR CODE		
OG - ORANGE	PR - PURPLE	BL - BLUE
RD - RED	GR - GREEN	BK - BLACK
BN - BROWN	YEL - YELLOW	WH - WHITE

1650 DEARBORN DRIVE, P.O. BOX 29186
COLUMBUS, OHIO 43229

CAGE CODE
1EDC2

©VERTIV CO.-CONFIDENTIAL AND PROPRIETARY - ALL RIGHTS RESERVED
THIS DOCUMENT (AND THE INFORMATION IT CONTAINS) ARE THE PROPERTY OF VERTIV CO. BY ACCEPTING IT INTO YOUR POSSESSION, YOU AGREE THAT YOU WILL KEEP THIS DOCUMENT, AND ALL INFORMATION CONTAINED HEREIN, IN STRICTEST CONFIDENCE, AND WILL NOT COPY, RE TRANSMIT, USE (EXPECT SOLELY FOR THE BENEFIT OF VERTIV CO.), SELL, LEND OR OTHERWISE DISPOSE OF THE SAME, DIRECTLY OR INDIRECTLY, WITHOUT THE EXPRESS WRITTEN PERMISSION OF VERTIV CO., AND THIS DOCUMENT SHALL BE RETURNED TO VERTIV CO. IMMEDIATELY UPON REQUEST.

VERTIV

ELECTRICAL SCHEMATIC

VERTIV® CRV DX 30kW
460V 3PH 50-60HZ
iCOM2 LARGE CONTROL
WITH HUMIDIFIER & REHEAT
HMI TOUCH SCREEN

POWER SUPPLY

SHEET 1 OF 4

DRAWN	P. BELMAREZ	DATE	2026/03/24
CHECKED	A. TORRES	DATE	2026/03/24
ENGR	A. TORRES	DATE	2026/03/24

DRAWING NO. 10080203DRW REV G

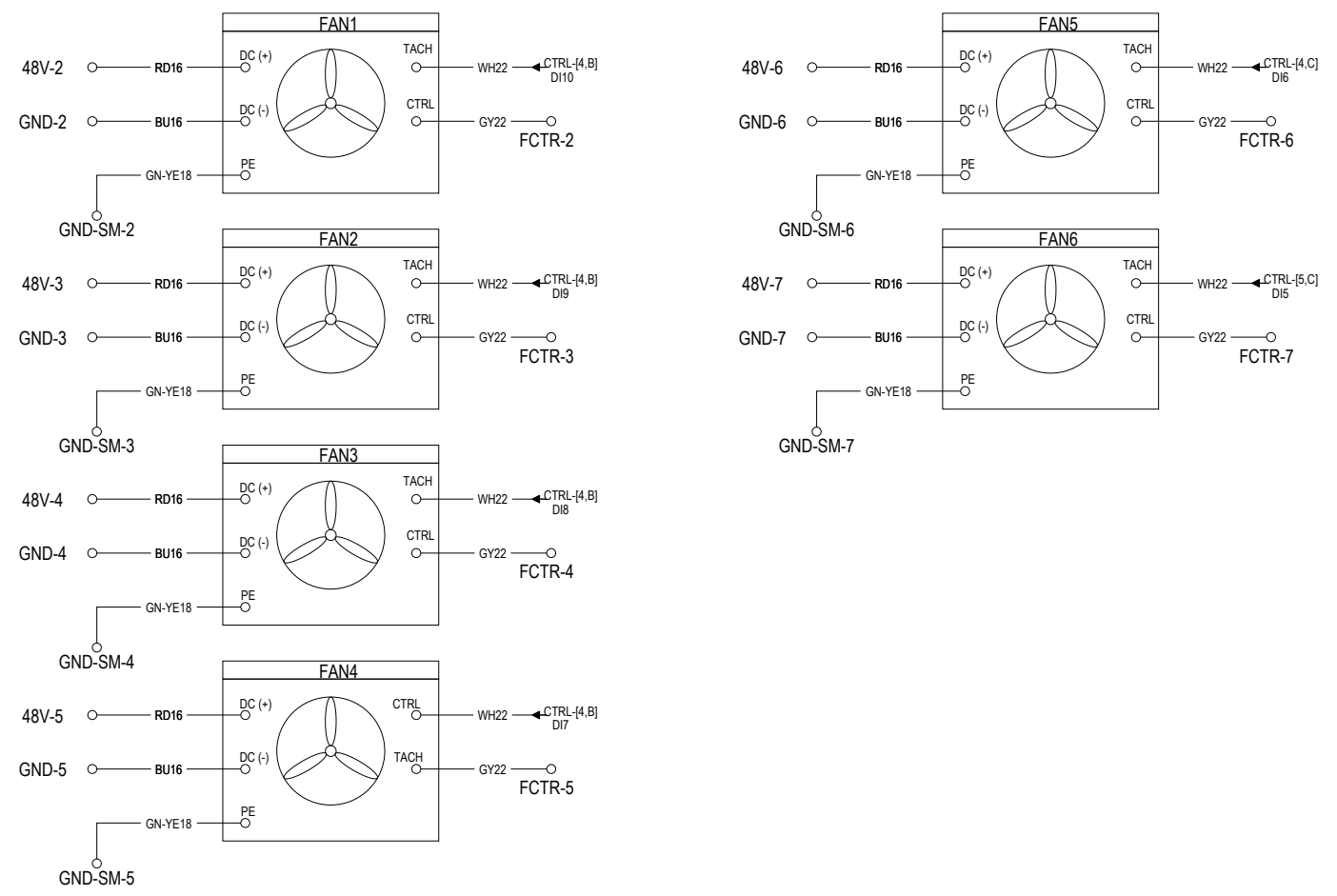
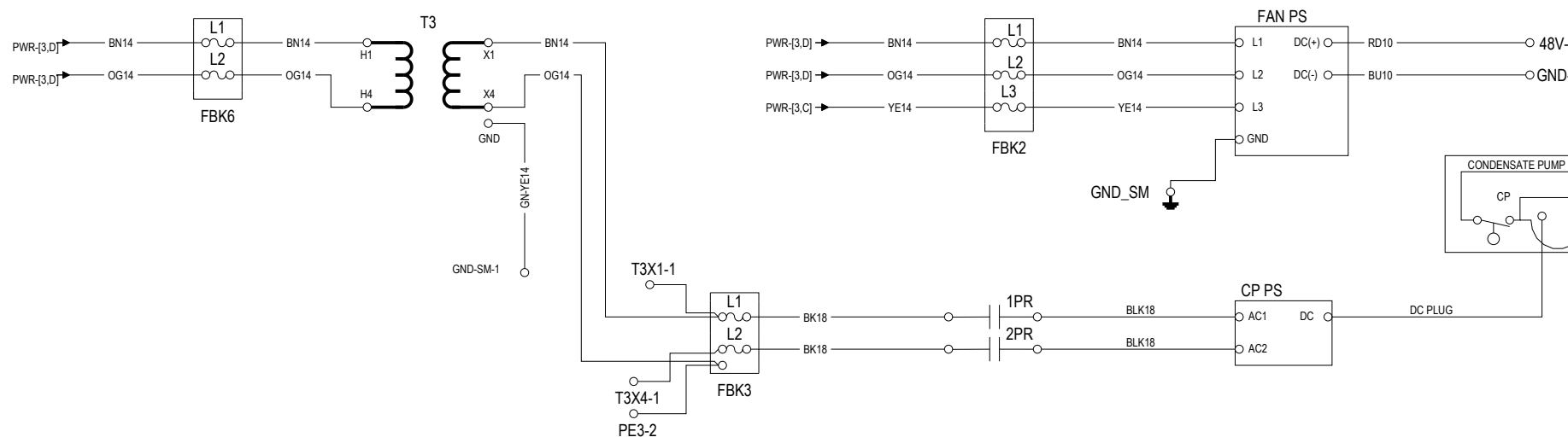

- NOTES:
1. ALL FIELD WIRING TO BE PER LOCAL CODES. USE COPPER CONDUCTORS ONLY.
 2. SEE INSTALLATION AND USER MANUAL(S).
 3. JUMPER TO BE REMOVED WHEN OPTIONAL COMPONENT IS USED.
 4. ALL RJ45/ETHERNET CABLES MUST BE STRAIGHT THROUGH.
 5. 10 DI CARD INSTALLED ON THE FAN PANEL.

NOMENCLATURE			
OPTIONAL DEVICES	COORD	OPTIONAL DEVICES	COORD
CPPS - CP POWER SUPPLY 24VDC	5,C		
FANPS - FANS POWER SUPPLY 48VDC	5,D		
FBK2 - FUSE BLOCK 2 FANS	6,D		
FBK3 - FUSE BLOCK 3 CP	6,C		
FBK6 - FUSE BLOCK 6 T3	8,D		
T3 - FAN TRANSFORMER	7,D		

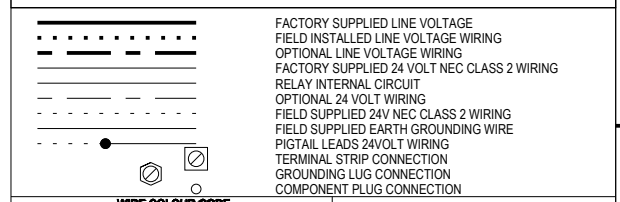

WIRE COLOUR CODE

OG - ORANGE	PR - PURPLE	BL - BLUE
RD - RED	GR - GREEN	BK - BLACK
BN - BROWN	YEL - YELLOW	WH - WHITE



1650 DEARBORN DRIVE, P.O. BOX 29186
COLUMBUS, OHIO 43229

CAGE CODE
1EDC2

©VERTIV CO.-CONFIDENTIAL AND PROPRIETARY - ALL RIGHTS RESERVED
THIS DOCUMENT (AND THE INFORMATION IT CONTAINS) ARE THE PROPERTY OF VERTIV CO. BY ACCEPTING IT INTO YOUR POSSESSION, YOU AGREE THAT YOU WILL KEEP THIS DOCUMENT, AND ALL INFORMATION CONTAINED HEREIN, IN STRICTEST CONFIDENCE, AND WILL NOT COPY, RE TRANSMIT, USE (EXPECT SOLELY FOR THE BENEFIT OF VERTIV CO.), SELL, LEND OR OTHERWISE DISPOSE OF THE SAME, DIRECTLY OR INDIRECTLY, WITHOUT THE EXPRESS WRITTEN PERMISSION OF VERTIV CO., AND THIS DOCUMENT SHALL BE RETURNED TO VERTIV CO. IMMEDIATELY UPON REQUEST.

ELECTRICAL SCHEMATIC

VERTIV® CRV DX 30kW
460V 3PH 50-60HZ
iCOM2 LARGE CONTROL
WITH HUMIDIFIER & REHEAT
HMI TOUCH SCREEN

DRAWN	DATE
P. BELMAREZ	2026/03/24
CHECKED	DATE
A. TORRES	2026/03/24
ENGR	DATE
A. TORRES	2026/03/24

DRAWING NO	REV
10080203DRW	G

FANS & CP
SHEET 2 OF 4

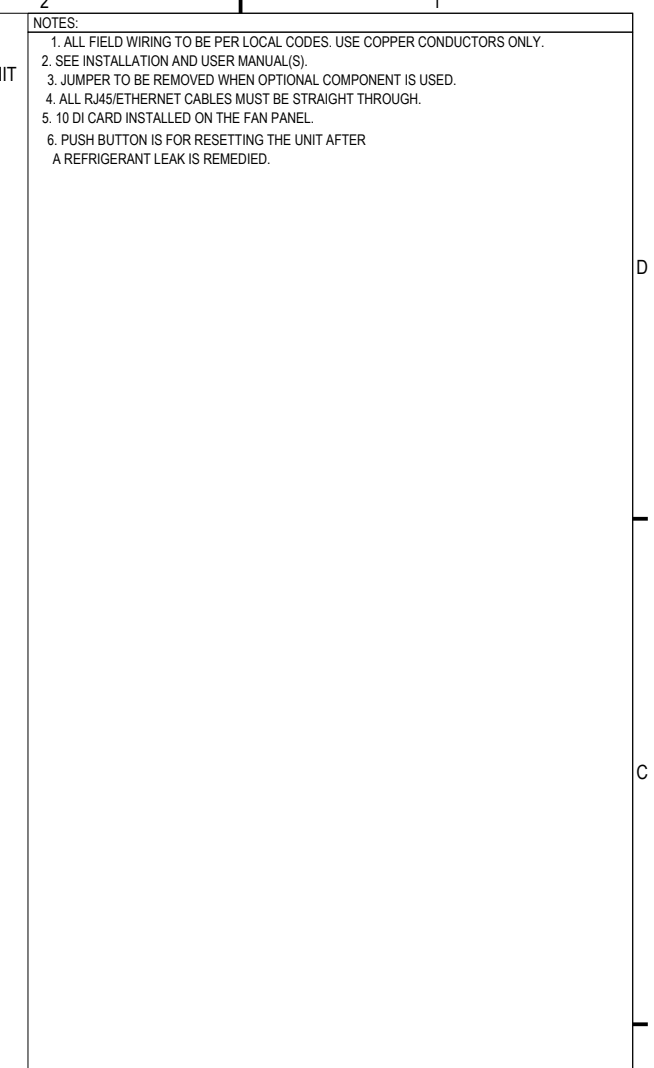
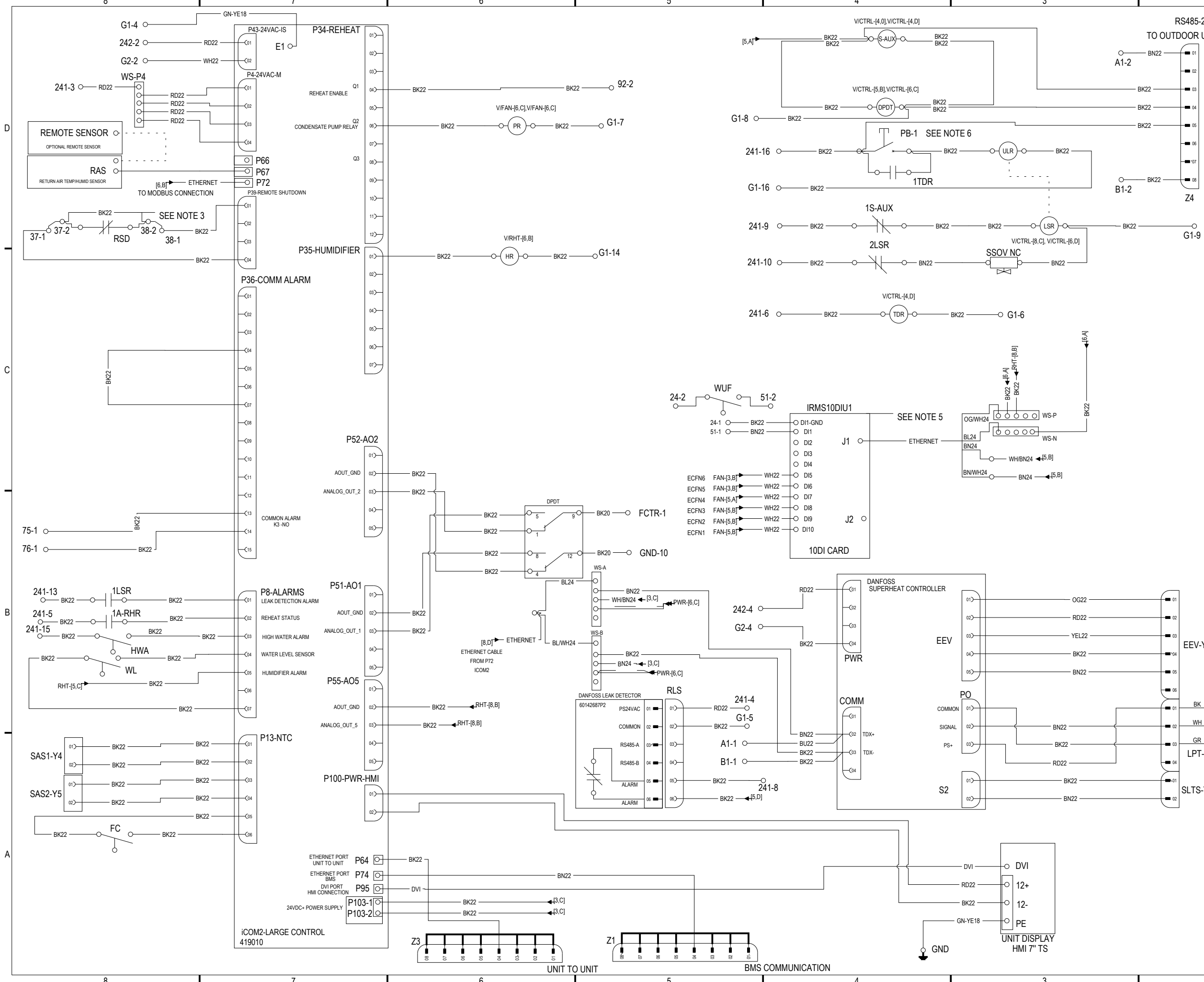

1. ALL FIELD WIRING TO BE PER LOCAL CODES. USE COPPER CONDUCTORS ONLY.
 2. SEE INSTALLATION AND USER MANUAL(S).
 3. JUMPER TO BE REMOVED WHEN OPTIONAL COMPONENT IS USED.
 4. ALL RJ45/ETHERNET CABLES MUST BE STRAIGHT THROUGH.
 5. 10 DI CARD INSTALLED ON THE FAN PANEL.
 6. PUSH BUTTON IS FOR RESETING THE UNIT AFTER A REFRIGERANT LEAK IS REMEDIED.

NOMENCLATURE			
STANDARD DEVICES	COORD	OPTIONAL DEVICES	COORD
EEV - ELECTRONIC EXP VALVE	3.A	RSD - REMOTE SHUTDOWN DEVICE	8.C
FC - FILTER CLOG SWITCH	8.C	SSOV - SAFETY SHUT-OFF VALVE	5.D
HR - HUMIDIFIER RELAY	6.C	WUF - WATER UNDER FLOOR	8.A
HWA - HIGH WATER ALARM	8.D		
LPT - LOW PRESSURE TRANSDUCER	3.A		
LSR - LEAK SENSOR RELAY	6.D		
PR - CONDENSATE PUMP RELAY	6.C		
RLS - REFRIGERANT LEAK SENSOR	6.A		
SAS1-4 - SUPPLY AIR SENSORS 1-4	8.B		
SLTS - SUCTION LINE TEMP SENSOR	3.A		
WL - WATER LEVEL SENSOR	8.C		
ULR - UNLATCHING RELAY	3.D		
TDR - TIME DELAY RELAY	4.D		

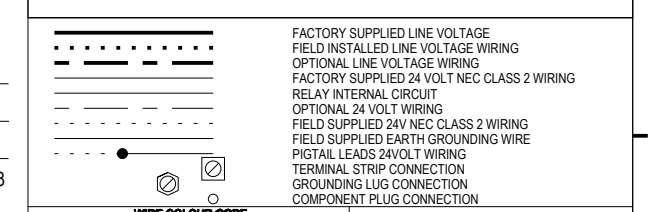

1650 DEARBORN DRIVE, P.O. BOX 29186
 COLUMBUS, OHIO 43229

CAGE CODE
 1EDC2

©VERTIV CO.-CONFIDENTIAL AND PROPRIETARY - ALL RIGHTS RESERVED
 THIS DOCUMENT AND THE INFORMATION IT CONTAINS ARE THE PROPERTY OF VERTIV CO. BY ACCEPTING IT INTO YOUR POSSESSION, YOU AGREE THAT YOU WILL KEEP THIS DOCUMENT, AND ALL INFORMATION CONTAINED HEREIN, IN STRICTEST CONFIDENCE, AND WILL NOT COPY, REPRODUCE, TRANSMIT, OR OTHERWISE DISCLOSE THE CONTENTS OF THIS DOCUMENT TO ANY OTHER PERSON OR ENTITY WITHOUT THE EXPRESS WRITTEN PERMISSION OF VERTIV CO. AND THIS DOCUMENT SHALL BE RETURNED TO VERTIV CO. IMMEDIATELY UPON REQUEST.

VERTIV

ELECTRICAL SCHEMATIC

VERTIV® CRV DX 30kW
 460V 3PH 50-60HZ
 iCOM2 LARGE CONTROL
 WITH HUMIDIFIER & REHEAT
 HMI TOUCH SCREEN
 CONTROL

SHEET 3 OF 3

DRAWN P. BELMAREZ	DATE 2026/03/24	DRAWING NO 10080203DRW	REV G
CHECKED A. TORRES	DATE 2026/03/24		
ENGR A. TORRES	DATE 2026/03/24		

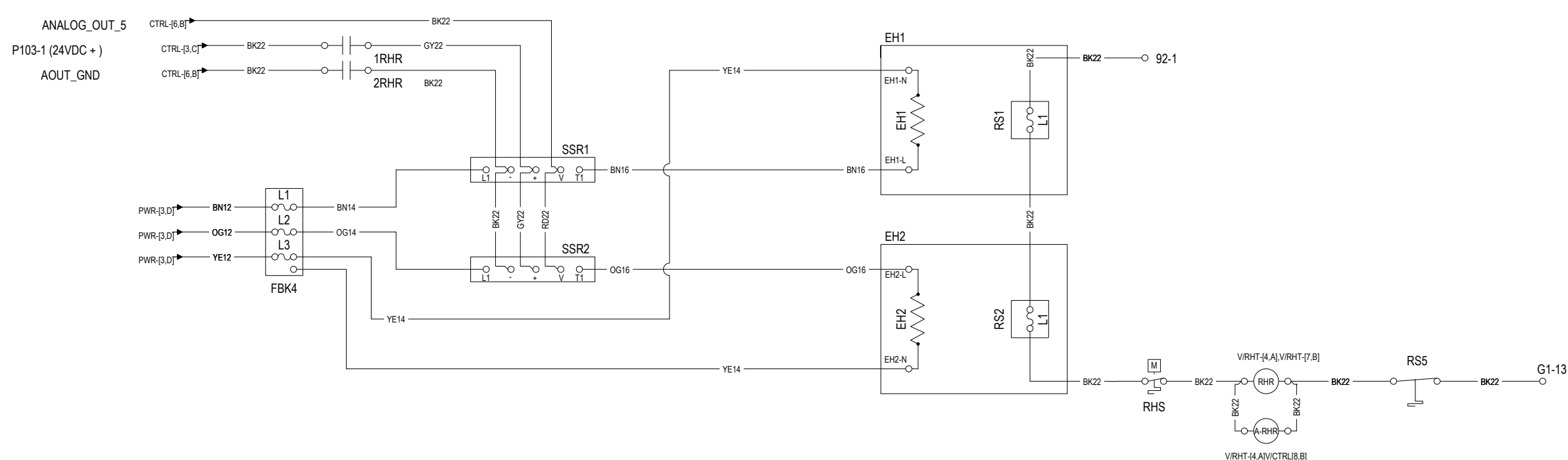
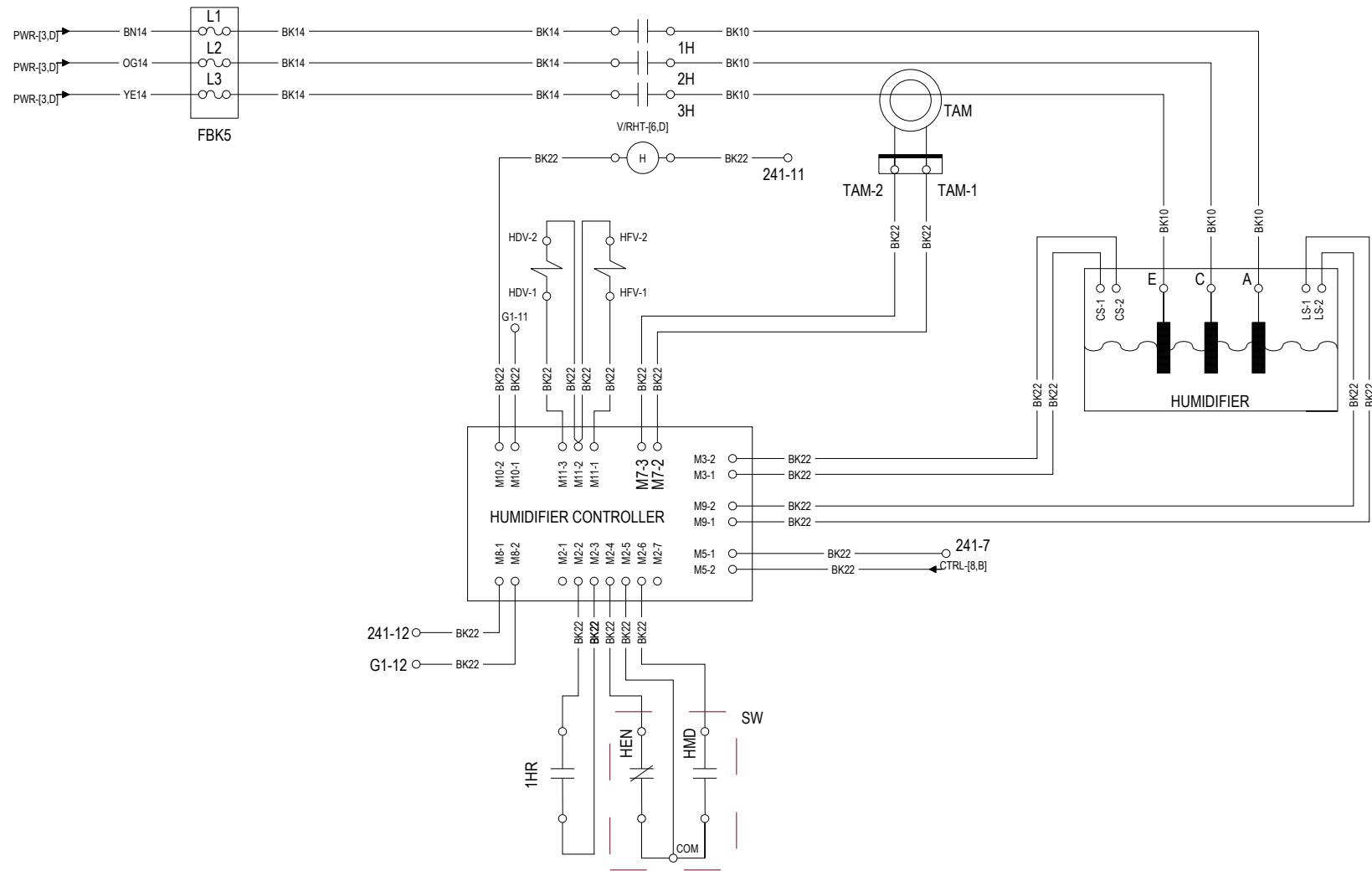

- NOTES:
1. ALL FIELD WIRING TO BE PER LOCAL CODES. USE COPPER CONDUCTORS ONLY.
 2. SEE INSTALLATION AND USER MANUAL(S).
 3. ALL RJ45/ETHERNET CABLES MUST BE STRAIGHT THROUGH.
 4. 10 DI CARD INSTALLED ON THE FAN PANEL.

NOMENCLATURE			
OPTIONAL DEVICES	COORD	OPTIONAL DEVICES	COORD
EH1 - ELECTRICAL REHEAT 1	5,B		
EH2 - ELECTRICAL REHEAT 2	5,A		
FBK4 - FUSE BLOCK 4 REHEAT	7,A		
FBK5 - FUSE BLOCK 5 HUMIDIFIER	7,D		
H - HUMIDIFIER CONTACTOR	6,D		
HDV - HUMIDIFIER DRAIN VALVE	6,D		
HFV - HUMIDIFIER FILL VALVE	6,D		
RHR - REHEAT RELAY	7,D		
RS5 - THERMAL CUT-OFF SWITCH	6,D		
SSR1 - SOLID STATE RELAY 1	6,B		
SSR2 - SOLID STATE RELAY 2	6,A		
TAM - HUM CURRENT TRANSFORMER	5,D		
RSS - MANUAL RESET THERMAL CUT-OFF SWITCH	4,D		

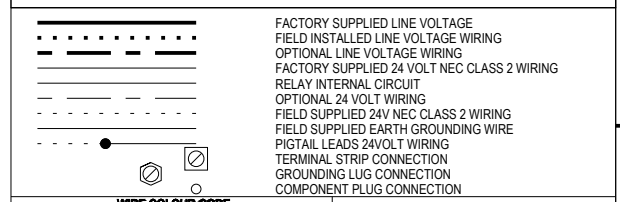

1650 DEARBORN DRIVE, P.O. BOX 29186
COLUMBUS, OHIO 43229

CAGE CODE
1EDC2

©VERTIV CO.-CONFIDENTIAL AND PROPRIETARY - ALL RIGHTS RESERVED
THIS DOCUMENT (AND THE INFORMATION IT CONTAINS) ARE THE PROPERTY OF VERTIV CO. BY ACCEPTING IT INTO YOUR POSSESSION, YOU AGREE THAT YOU WILL KEEP THIS DOCUMENT, AND ALL INFORMATION CONTAINED HEREIN, IN STRICTEST CONFIDENCE, AND WILL NOT COPY, REPRODUCE, TRANSMIT, USE (EXPECT SOLELY FOR THE BENEFIT OF VERTIV CO.), SELL, LEND OR OTHERWISE DISPOSE OF THE SAME, DIRECTLY OR INDIRECTLY, WITHOUT THE EXPRESS WRITTEN PERMISSION OF VERTIV CO., AND THIS DOCUMENT SHALL BE RETURNED TO VERTIV CO. IMMEDIATELY UPON REQUEST.

VERTIV

ELECTRICAL SCHEMATIC

VERTIV® CRV DX 30kW
460V 3PH 50-60HZ
iCOM2 LARGE CONTROL
WITH HUMIDIFIER & REHEAT
HMI TOUCH SCREEN

REHEAT & HUMIDIFIER

SHEET 4 OF 4

DRAWN	P. BELMAREZ	DATE	2026/03/24
CHECKED	A. TORRES	DATE	2026/03/24
ENGR	P. BELMAREZ	DATE	2026/03/24

DRAWING NO
10080203DRW

REV
G

LINE VOLTAGE
3 PHASE SUPPLY (A)

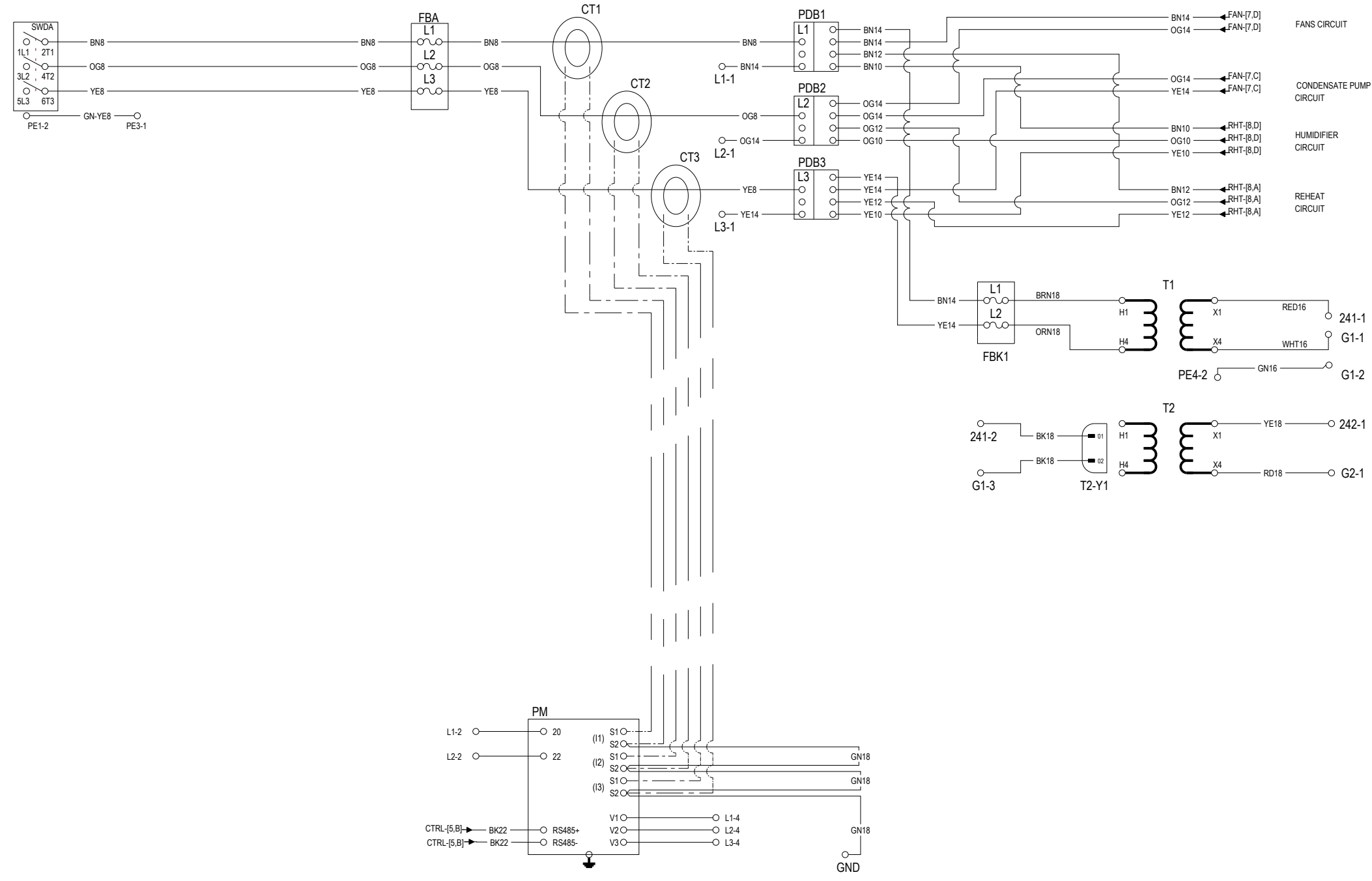

- NOTES:
1. ALL FIELD WIRING TO BE PER LOCAL CODES. USE COPPER CONDUCTORS ONLY.
 2. SEE INSTALLATION AND USER MANUAL(S).
 3. JUMPER TO BE REMOVED WHEN OPTIONAL COMPONENT IS USED.
 4. ALL RJ45/ETHERNET CABLES MUST BE STRAIGHT THROUGH.
 5. 10 DI CARD INSTALLED ON THE FAN PANEL.

NOMENCLATURE			
STANDARD DEVICES	COORD	OPTIONAL DEVICES	COORD
FBA - FUSE BLOCK A	6.D	CT1 - CURRENT TRANSFORMER 1	5.D
FBB - FUSE BLOCK B	6.D	CT2 - CURRENT TRANSFORMER 2	5.D
FBK1 - FUSE BLOCK 1 CONTROL	4.C	CT3 - CURRENT TRANSFORMER 3	5.D
KAC - CONTACTOR RELAY ATS C	6.C	PM - POWER METER	5.B
KAD - CONTACTOR RELAY ATS D	6.C		
KMA - CONTACTOR ATS A	6.C		
KMB - CONTACTOR ATS B	5.C		
PDB1 - POWER DIST BLOCK L1	5.D		
PDB2 - POWER DIST BLOCK L2	5.D		
PDB3 - POWER DIST BLOCK L3	5.D		
SWDA - SWITCH DISCONNECT A	8.D		
SWDB - SWITCH DISCONNECT B	8.D		
T1 - CONTROL TRANSFORMER	3.C		
T2 - ISOLATION TRANSFORMER	3.C		

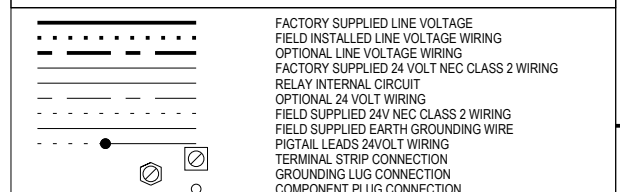

WIRE COLOUR CODE		
OG - ORANGE	PR - PURPLE	BL - BLUE
RD - RED	GR - GREEN	BK - BLACK
BN - BROWN	YEL - YELLOW	WH - WHITE



1650 DEARBORN DRIVE, P.O. BOX 29186
COLUMBUS, OHIO 43229

CAGE CODE
1EDC2

©VERTIV CO.-CONFIDENTIAL AND PROPRIETARY - ALL RIGHTS RESERVED
THIS DOCUMENT (AND THE INFORMATION IT CONTAINS) ARE THE PROPERTY OF VERTIV CO. BY ACCEPTING IT INTO YOUR POSSESSION, YOU AGREE THAT YOU WILL KEEP THIS DOCUMENT, AND ALL INFORMATION CONTAINED HEREIN, IN STRICTEST CONFIDENCE, AND WILL NOT COPY, RE TRANSMIT, USE (EXCEPT SOLELY FOR THE BENEFIT OF VERTIV CO.), SELL, LEND OR OTHERWISE DISPOSE OF THE SAME, DIRECTLY OR INDIRECTLY, WITHOUT THE EXPRESS WRITTEN PERMISSION OF VERTIV CO., AND THIS DOCUMENT SHALL BE RETURNED TO VERTIV CO. IMMEDIATELY UPON REQUEST.

ELECTRICAL SCHEMATIC
VERTIV® CRV DX 40kW
208-230V 3PH 50-60HZ
iCOM2 LARGE CONTROL
WITH HUMIDIFIER & REHEAT
HMI TOUCH SCREEN

DRAWN	DATE
P. BELMAREZ	2026/03/24
CHECKED	DATE
A. TORRES	2026/03/24
ENGR	DATE
A. TORRES	2026/03/24

POWER SUPPLY
SHEET 1 OF 4
DRAWING NO. 10080204DRW
REV G

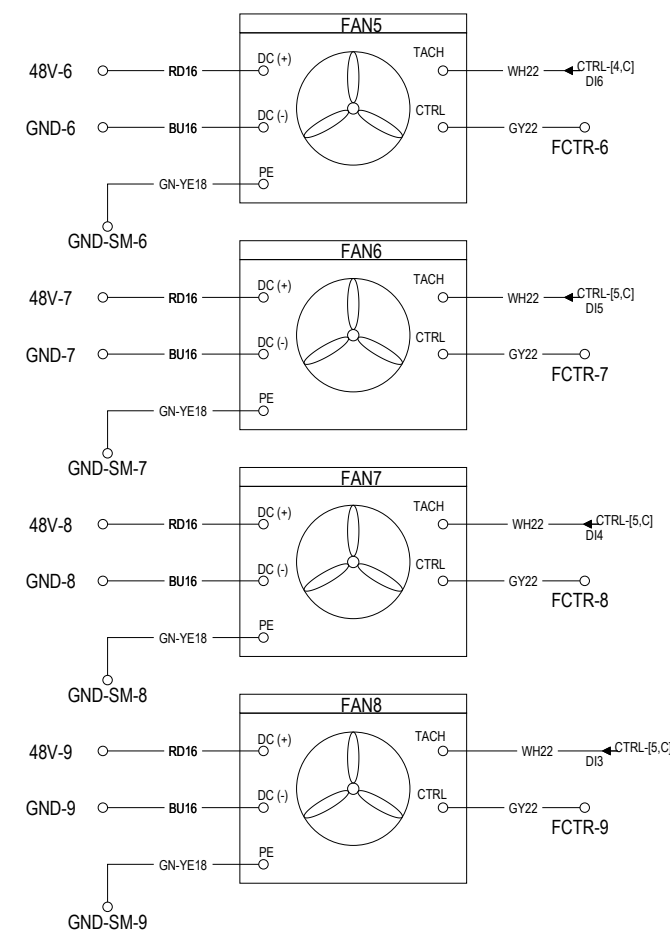
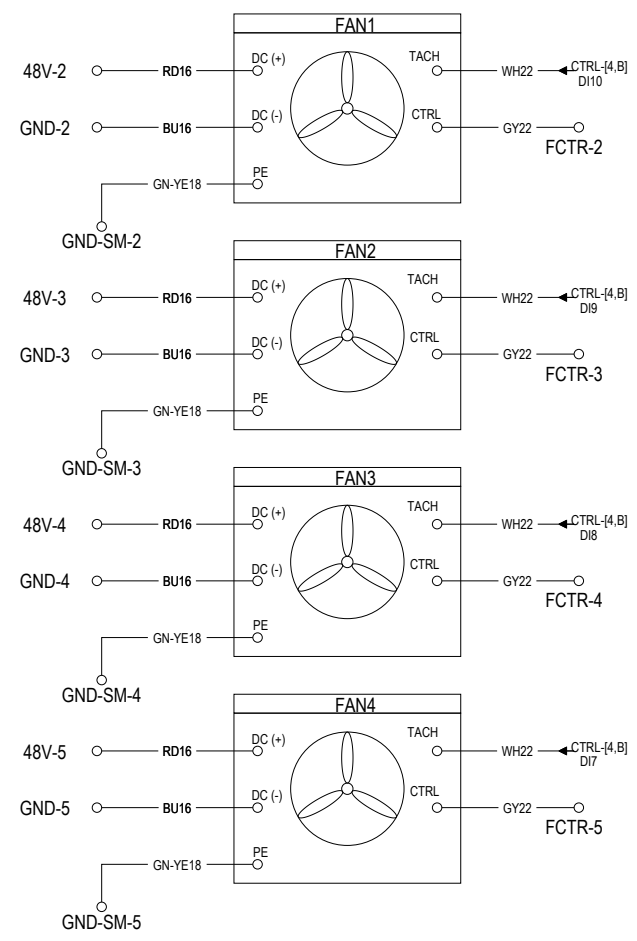
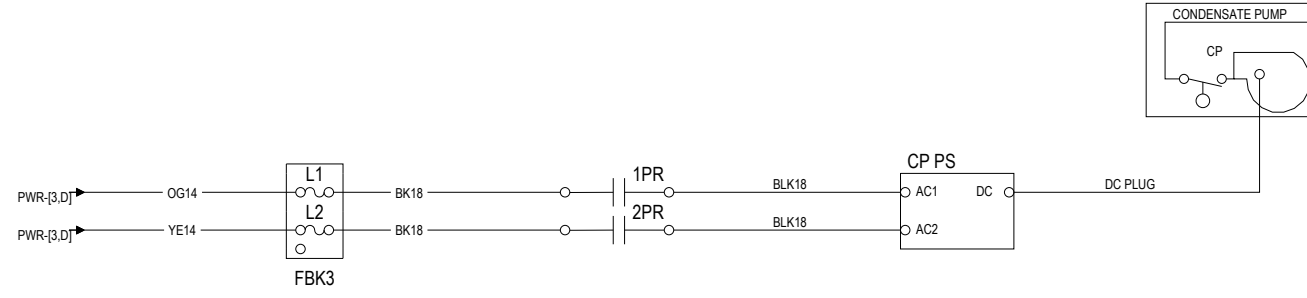
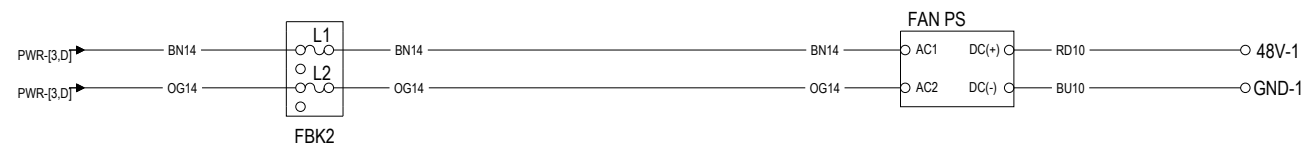

- NOTES:
1. ALL FIELD WIRING TO BE PER LOCAL CODES. USE COPPER CONDUCTORS ONLY.
 2. SEE INSTALLATION AND USER MANUAL(S).
 3. JUMPER TO BE REMOVED WHEN OPTIONAL COMPONENT IS USED.
 4. ALL RJ45/ETHERNET CABLES MUST BE STRAIGHT THROUGH.
 5. 10 DI CARD INSTALLED ON THE FAN PANEL.

NOMENCLATURE			
STANDARD DEVICES	COORD	OPTIONAL DEVICES	COORD
CPPS - CP POWER SUPPLY 24VDC	5.C		
FANPS - FANS POWER SUPPLY 48VDC	5.D		
FBK2 - FUSE BLOCK 2 FANS	6.D		
FBK3 - FUSE BLOCK 3 CP	6.C		

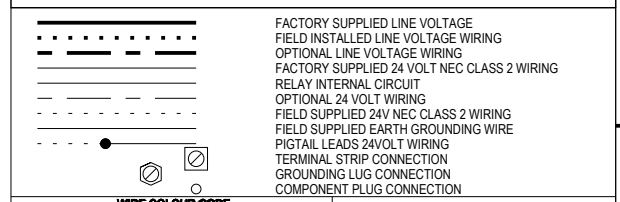

WIRE COLOUR CODE		
OG - ORANGE	PR - PURPLE	BL - BLUE
RD - RED	GR - GREEN	BK - BLACK
BN - BROWN	YEL - YELLOW	WH - WHITE



1650 DEARBORN DRIVE, P.O. BOX 29186
COLUMBUS, OHIO 43229

CAGE CODE
1EDC2

©VERTIV CO.-CONFIDENTIAL AND PROPRIETARY - ALL RIGHTS RESERVED
THIS DOCUMENT (AND THE INFORMATION IT CONTAINS) ARE THE PROPERTY OF VERTIV CO. BY ACCEPTING IT INTO YOUR POSSESSION, YOU AGREE THAT YOU WILL KEEP THIS DOCUMENT, AND ALL INFORMATION CONTAINED HEREIN, IN STRICTEST CONFIDENCE, AND WILL NOT COPY, RE TRANSMIT, USE (EXPECT SOLELY FOR THE BENEFIT OF VERTIV CO.), SELL, LEND OR OTHERWISE DISPOSE OF THE SAME, DIRECTLY OR INDIRECTLY, WITHOUT THE EXPRESS WRITTEN PERMISSION OF VERTIV CO., AND THIS DOCUMENT SHALL BE RETURNED TO VERTIV CO. IMMEDIATELY UPON REQUEST.

ELECTRICAL SCHEMATIC
VERTIV® CRV DX 40kW
208-230V 3PH 50-60HZ
iCOM2 LARGE CONTROL
WITH HUMIDIFIER & REHEAT
HMI TOUCH SCREEN

DRAWN	DATE
P. BELMAREZ	2026/03/24
CHECKED	DATE
A. TORRES	2026/03/24
ENGR	DATE
A. TORRES	2026/03/24

FANS & CP
SHEET 2 OF 4
DRAWING NO. 10080204DRW
REV G

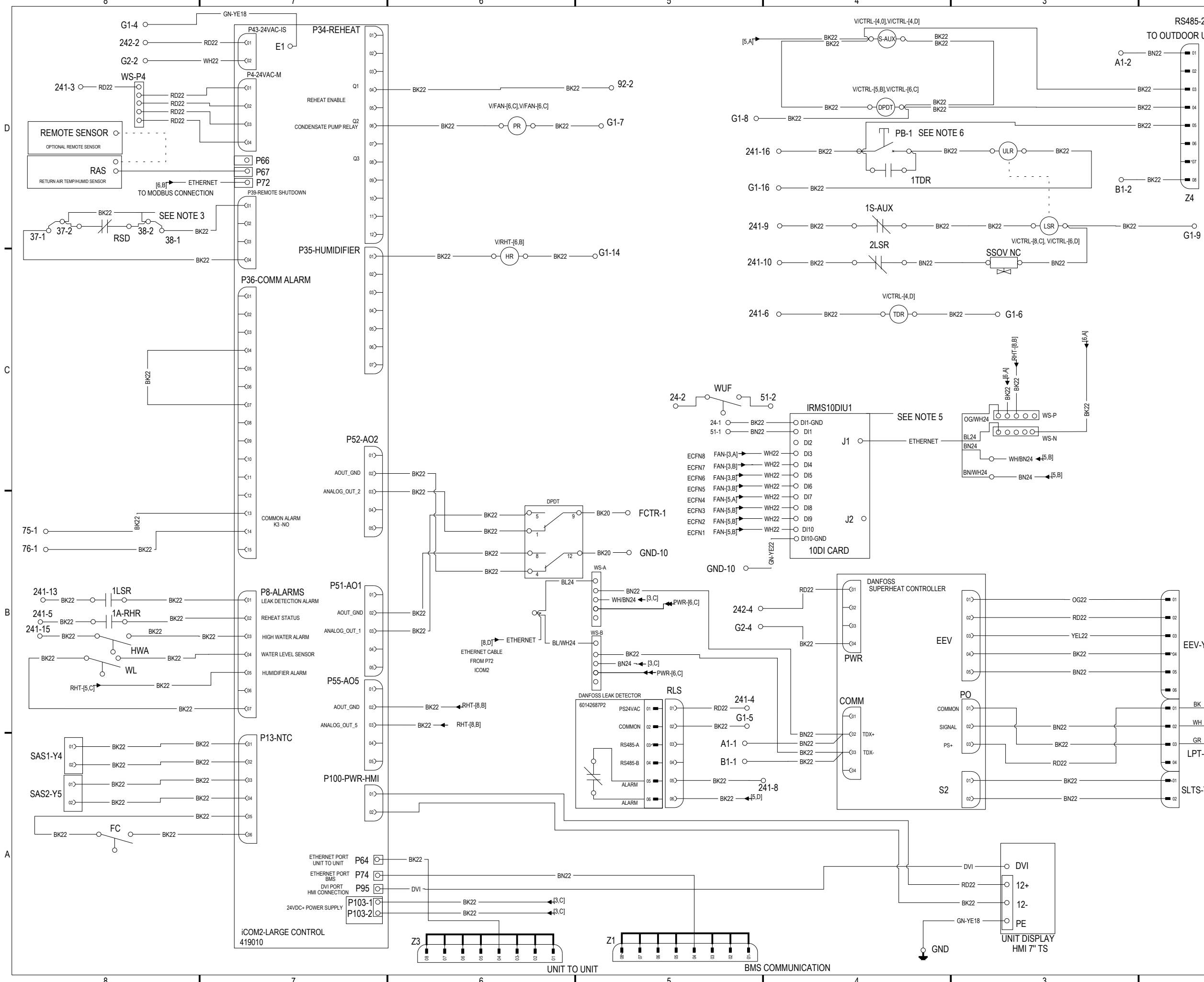

- NOTES:
1. ALL FIELD WIRING TO BE PER LOCAL CODES. USE COPPER CONDUCTORS ONLY.
 2. SEE INSTALLATION AND USER MANUAL(S).
 3. JUMPER TO BE REMOVED WHEN OPTIONAL COMPONENT IS USED.
 4. ALL RJ45/ETHERNET CABLES MUST BE STRAIGHT THROUGH.
 5. 10 DI CARD INSTALLED ON THE FAN PANEL.
 6. PUSH BUTTON IS FOR RESETTING THE UNIT AFTER A REFRIGERANT LEAK IS REMEDIATED.

NOMENCLATURE			
STANDARD DEVICES	COORD	OPTIONAL DEVICES	COORD
EEV - ELECTRONIC EXP VALVE	3.A	RSD - REMOTE SHUTDOWN DEVICE	8.C
FC - FILTER CLOG SWITCH	8.C	SSOV - SAFETY SHUT-OFF VALVE	5.D
HR - HUMIDIFIER RELAY	6.C	WUF - WATER UNDER FLOOR	8.A
HWA - HIGH WATER ALARM	8.D		
LPT - LOW PRESSURE TRANSDUCER	3.A		
LSR - LEAK SENSOR RELAY	6.D		
PR - CONDENSATE PUMP RELAY	6.C		
RLS - REFRIGERANT LEAK SENSOR	6.A		
SAS1-4 - SUPPLY AIR SENSORS 1-4	8.B		
SLTS - SUCTION LINE TEMP SENSOR	3.A		
WL - WATER LEVEL SENSOR	8.C		
ULR - UNLATCHING RELAY	3.D		
TDR - TIME DELAY RELAY	4.D		

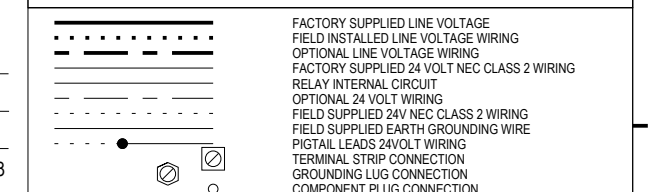

WIRE COLOUR CODE		
OG - ORANGE	PR - PURPLE	BL - BLUE
RD - RED	GR - GREEN	BK - BLACK
BN - BROWN	YEL - YELLOW	WH - WHITE

1650 DEARBORN DRIVE, P.O. BOX 29186
COLUMBUS, OHIO 43229

CAGE CODE
1EDC2

©VERTIV CO.-CONFIDENTIAL AND PROPRIETARY - ALL RIGHTS RESERVED
THIS DOCUMENT (AND THE INFORMATION IT CONTAINS) ARE THE PROPERTY OF VERTIV CO. BY ACCEPTING IT INTO YOUR POSSESSION, YOU AGREE THAT YOU WILL KEEP THIS DOCUMENT, AND ALL INFORMATION CONTAINED HEREIN, IN STRICTEST CONFIDENCE, AND WILL NOT COPY, REPRODUCE, TRANSMIT, USE (EXPECT SOLELY FOR THE BENEFIT OF VERTIV CO.), SELL, LEND OR OTHERWISE DISPOSE OF THE SAME, DIRECTLY OR INDIRECTLY, WITHOUT THE EXPRESS WRITTEN PERMISSION OF VERTIV CO., AND THIS DOCUMENT SHALL BE RETURNED TO VERTIV CO. IMMEDIATELY UPON REQUEST.

VERTIV

ELECTRICAL SCHEMATIC

VERTIV® CRV DX 40kW
208-230V 3PH 50-60HZ
iCOM2 LARGE CONTROL
WITH HUMIDIFIER & REHEAT
HMI TOUCH SCREEN
CONTROL

SHEET 3 OF 4

DRAWN P. BELMAREZ	DATE 2026/03/24	DRAWING NO 10080204DRW	REV G
CHECKED A. TORRES	DATE 2026/03/24		
ENGR A. TORRES	DATE 2026/03/24		

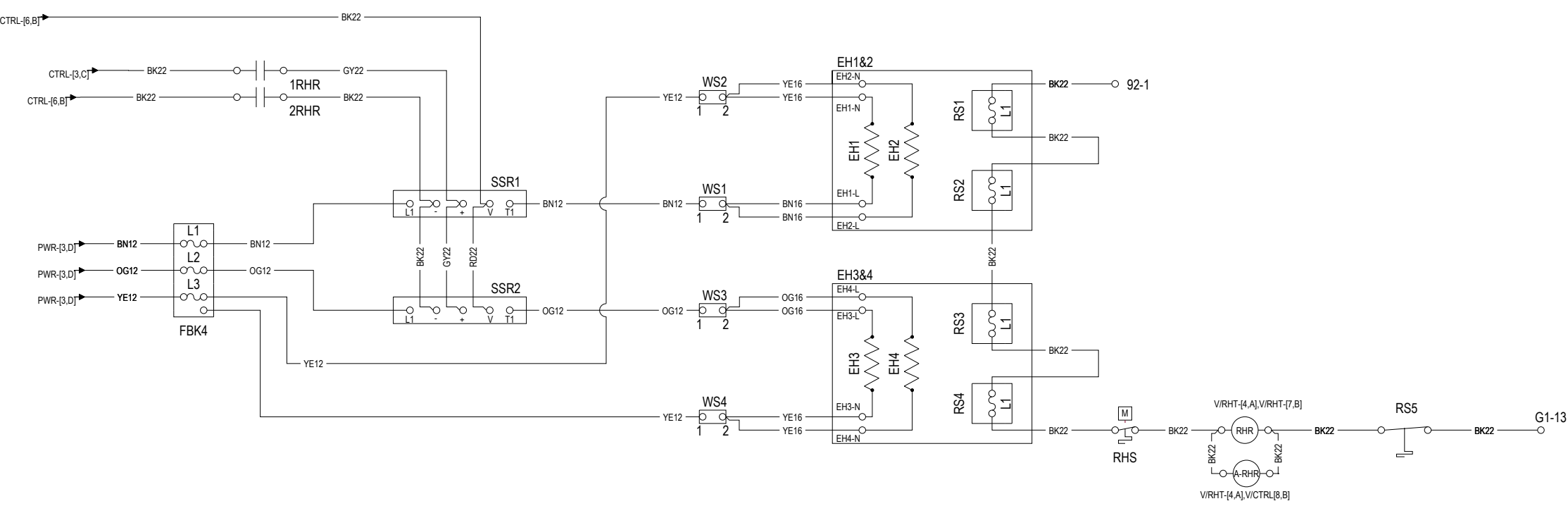
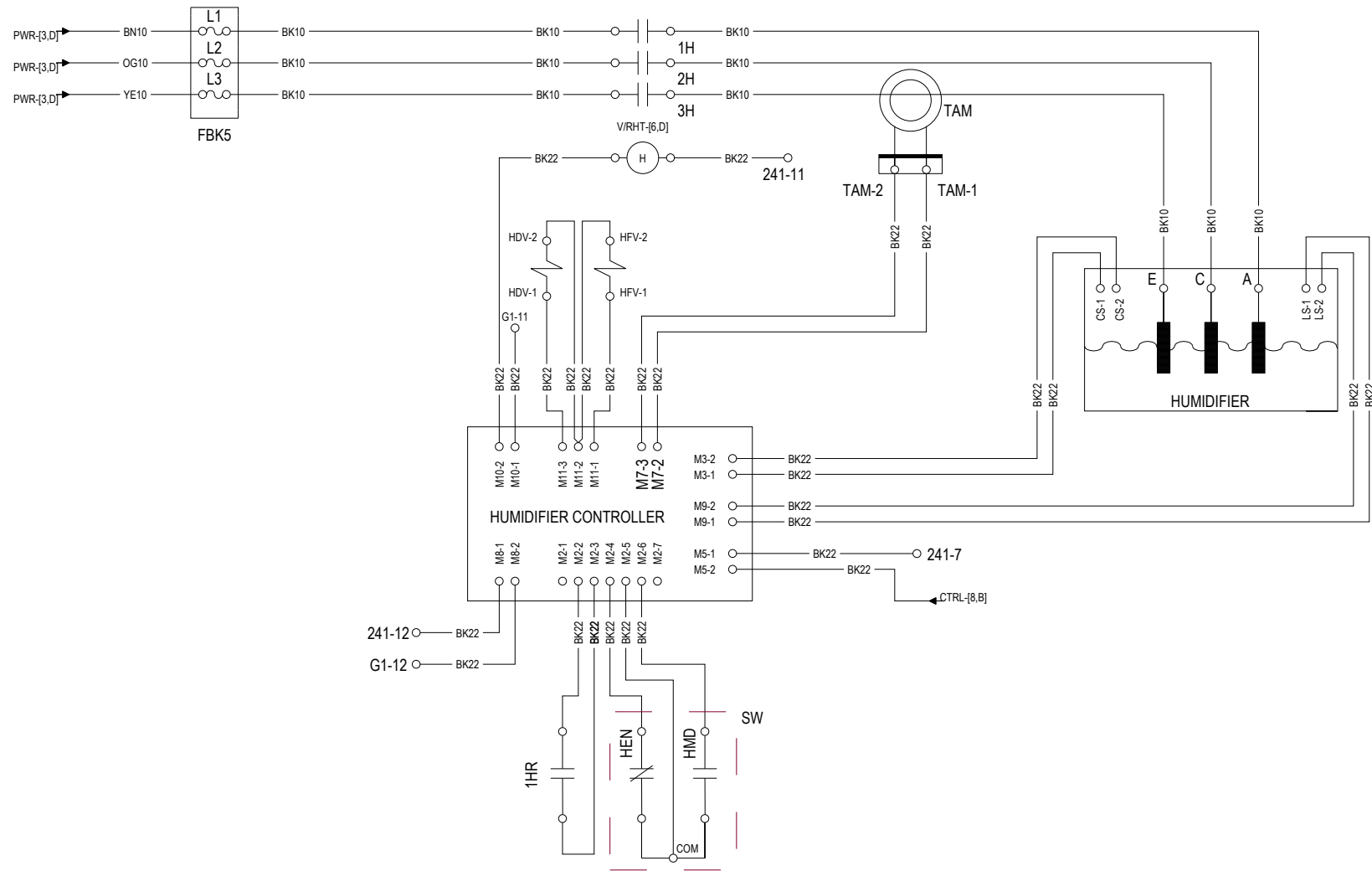

- NOTES:
1. ALL FIELD WIRING TO BE PER LOCAL CODES. USE COPPER CONDUCTORS ONLY.
 2. SEE INSTALLATION AND USER MANUAL(S).
 3. ALL RJ45/ETHERNET CABLES MUST BE STRAIGHT THROUGH.
 4. 10 DI CARD INSTALLED ON THE FAN PANEL.

NOMENCLATURE			
STANDARD DEVICES	COORD	OPTIONAL DEVICES	COORD
EH1-2 - ELECTRICAL REHEAT 1, 2	5,B		
EH3-4 - ELECTRICAL REHEAT 3, 4	5,A		
FBK4 - FUSE BLOCK 4 REHEAT	7,A		
FBK5 - FUSE BLOCK 5 HUMIDIFIER	7,D		
H - HUMIDIFIER CONTACTOR	6,D		
HDV - HUMIDIFIER DRAIN VALVE	6,D		
HFV - HUMIDIFIER FILL VALVE	6,D		
RHR - REHEAT RELAY	7,D		
RS5 - THERMAL CUT-OFF SWITCH	6,D		
SSR1 - SOLID STATE RELAY 1	6,B		
SSR2 - SOLID STATE RELAY 2	6,A		
TAM - HUM CURRENT TRANSFORMER	5,D		
A-RHR - AUXILIARY CONTACT RHR			
RHS - MANUAL RESET THERMAL CUT-OFFSWITCH	4,D		

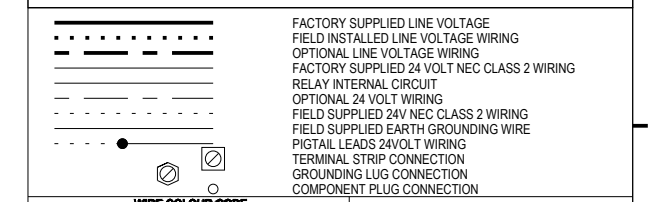

WIRE COLOUR CODE		
OG - ORANGE	PR - PURPLE	BL - BLUE
RD - RED	GR - GREEN	BK - BLACK
BN - BROWN	YEL - YELLOW	WH - WHITE

1650 DEARBORN DRIVE, P.O. BOX 29186
COLUMBUS, OHIO 43229

CAGE CODE
1EDC2

©VERTIV CO.-CONFIDENTIAL AND PROPRIETARY - ALL RIGHTS RESERVED
THIS DOCUMENT (AND THE INFORMATION IT CONTAINS) ARE THE PROPERTY OF VERTIV CO. BY ACCEPTING IT INTO YOUR POSSESSION, YOU AGREE THAT YOU WILL KEEP THIS DOCUMENT, AND ALL INFORMATION CONTAINED HEREIN, IN STRICTEST CONFIDENCE, AND WILL NOT COPY, REPRODUCE, TRANSMIT, USE (EXPECT SOLELY FOR THE BENEFIT OF VERTIV CO.), SELL, LEND OR OTHERWISE DISPOSE OF THIS SAME, DIRECTLY OR INDIRECTLY, WITHOUT THE EXPRESS WRITTEN PERMISSION OF VERTIV CO., AND THIS DOCUMENT SHALL BE RETURNED TO VERTIV CO. IMMEDIATELY UPON REQUEST.

ELECTRICAL SCHEMATIC
VERTIV® CRV DX 40kW
208-230V 3PH 50-60HZ
iCOM2 LARGE CONTROL
WITH HUMIDIFIER & REHEAT
HMI TOUCH SCREEN

REHEAT & HUMIDIFIER

DRAWN	P. BELMAREZ	DATE	2026/03/24
CHECKED	A. TORRES	DATE	2026/03/24
ENGR	A. TORRES	DATE	2026/03/24

DRAWING NO. 10080204DRW

REV G

SHEET 4 OF 4

LINE VOLTAGE
3 PHASE SUPPLY (A)

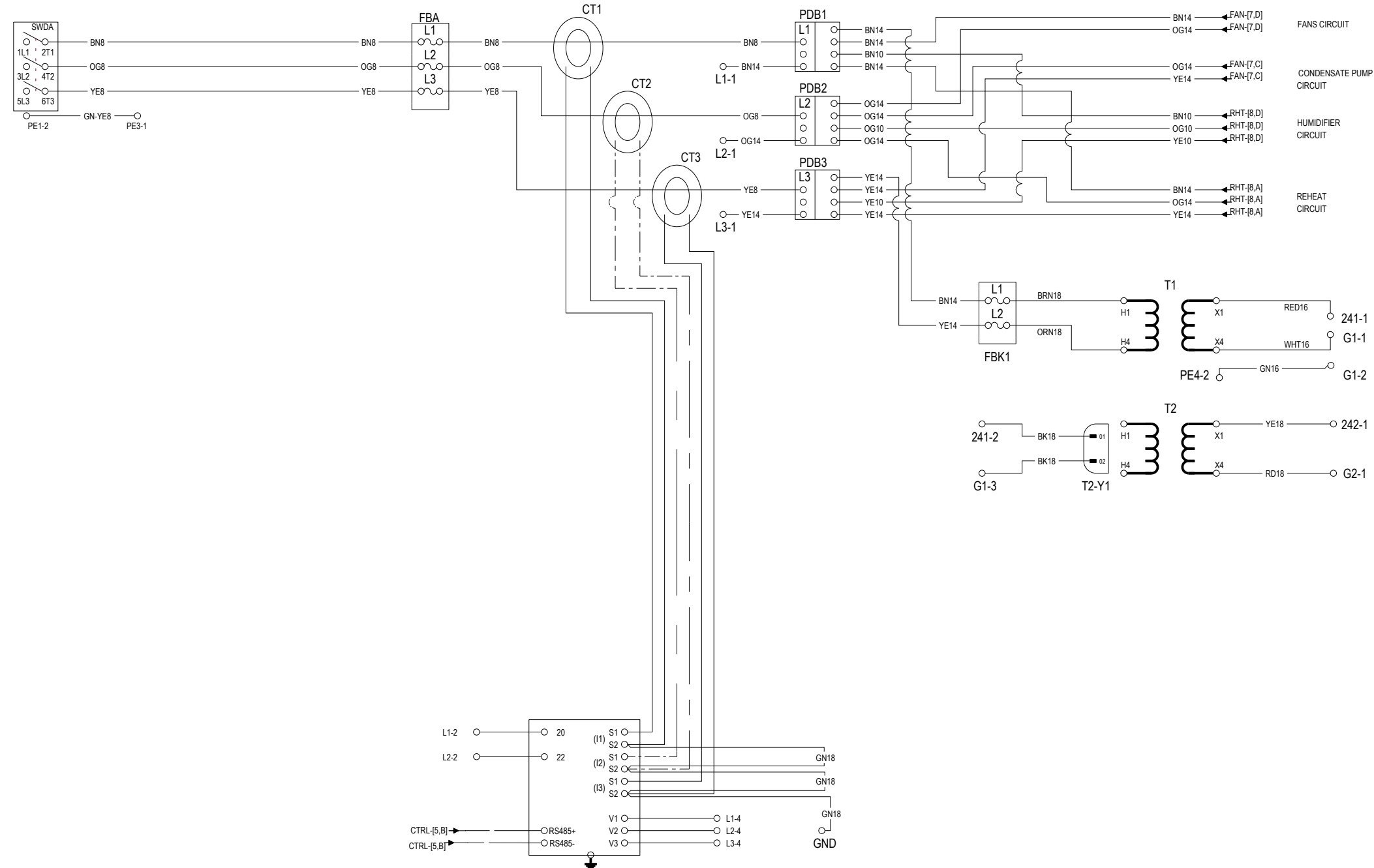

- NOTES:
1. ALL FIELD WIRING TO BE PER LOCAL CODES. USE COPPER CONDUCTORS ONLY.
 2. SEE INSTALLATION AND USER MANUAL(S).
 3. JUMPER TO BE REMOVED WHEN OPTIONAL COMPONENT IS USED.
 4. ALL RJ45/ETHERNET CABLES MUST BE STRAIGHT THROUGH.
 5. 10 DI CARD INSTALLED ON THE FAN PANEL.

NOMENCLATURE			
STANDARD DEVICES	COORD	OPTIONAL DEVICES	COORD
FBA - FUSE BLOCK A	6.D	CT1 - CURRENT TRANSFORMER 1	5.D
FBB - FUSE BLOCK B	6.D	CT2 - CURRENT TRANSFORMER 2	5.D
FBK1 - FUSE BLOCK 1 CONTROL	4.C	CT3 - CURRENT TRANSFORMER 3	5.D
KAC - CONTACTOR RELAY ATS C	6.C	PM - POWER METER	5.B
KAD - CONTACTOR RELAY ATS D	6.C		
KMA - CONTACTOR ATS A	6.C		
KMB - CONTACTOR ATS B	5.C		
PDB1 - POWER DIST BLOCK L1	5.D		
PDB2 - POWER DIST BLOCK L2	5.D		
PDB3 - POWER DIST BLOCK L3	5.D		
SWDA - SWITCH DISCONNECT A	8.D		
SWDB - SWITCH DISCONNECT B	8.D		
T1 - CONTROL TRANSFORMER	3.C		
T2 - ISOLATION TRANSFORMER	3.C		

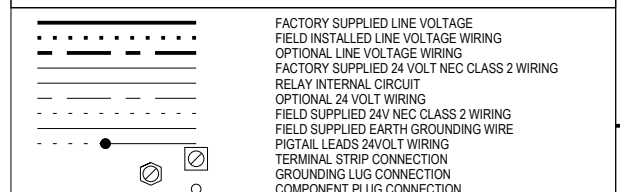

WIRE COLOUR CODE		
OG - ORANGE	FR - PURPLE	BL - BLUE
RD - RED	GR - GREEN	BK - BLACK
BN - BROWN	YEL - YELLOW	WH - WHITE

1650 DEARBORN DRIVE, P.O. BOX 29186
COLUMBUS, OHIO 43229

CAGE CODE
1EDC2

©VERTIV CO.-CONFIDENTIAL AND PROPRIETARY - ALL RIGHTS RESERVED
THIS DOCUMENT (AND THE INFORMATION IT CONTAINS) ARE THE PROPERTY OF VERTIV CO. BY ACCEPTING IT INTO YOUR POSSESSION, YOU AGREE THAT YOU WILL KEEP THIS DOCUMENT, AND ALL INFORMATION CONTAINED HEREIN, IN STRICTEST CONFIDENCE, AND WILL NOT COPY, RE TRANSMIT, USE (EXPECT SOLELY FOR THE BENEFIT OF VERTIV CO.), SELL, LEND OR OTHERWISE DISPOSE OF THE SAME, DIRECTLY OR INDIRECTLY, WITHOUT THE EXPRESS WRITTEN PERMISSION OF VERTIV CO., AND THIS DOCUMENT SHALL BE RETURNED TO VERTIV CO. IMMEDIATELY UPON REQUEST.

VERTIV

ELECTRICAL SCHEMATIC
VERTIV® CRV DX 30kW
208-230V 3PH 50-60HZ
iCOM2 LARGE CONTROL
WITH HUMIDIFIER & REHEAT
HMI TOUCH SCREEN

POWER SUPPLY

SHEET 1 OF 4

DRAWN P. BELMAREZ	DATE 2026/03/24	DRAWING NO 10080205DRW	REV G
CHECKED A. TORRES	DATE 2026/03/24		
ENGR A. TORRES	DATE 2026/03/24		

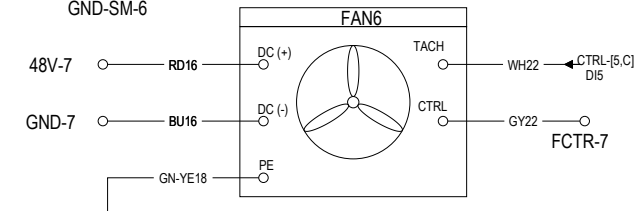
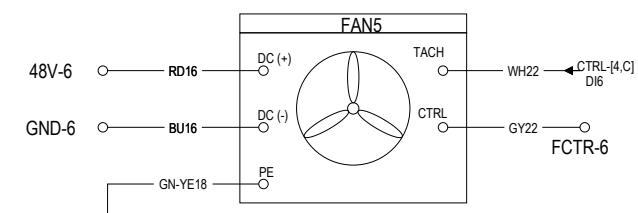
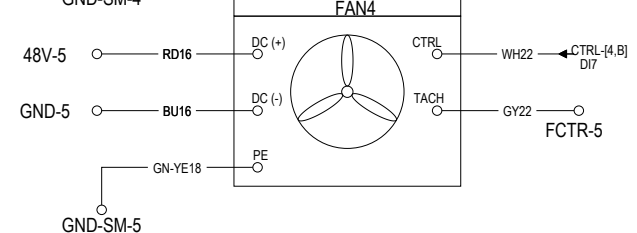
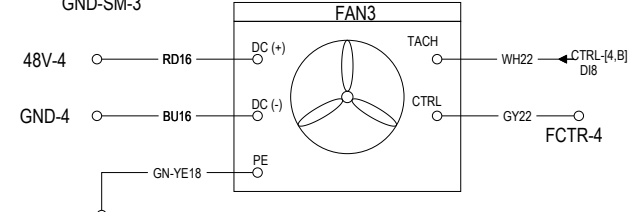
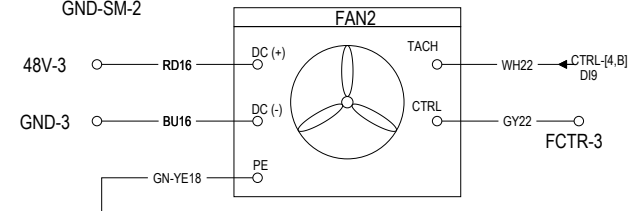
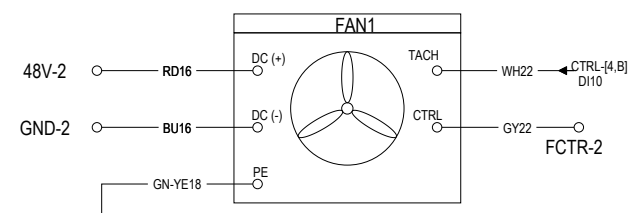
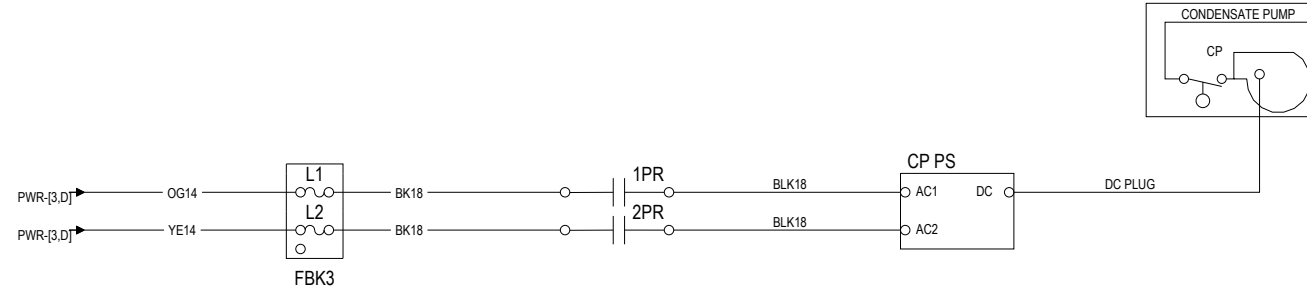
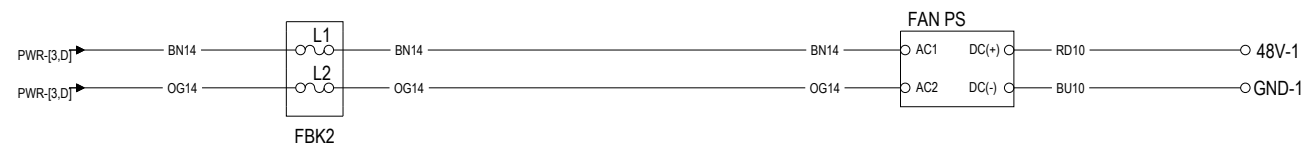

- NOTES:
1. ALL FIELD WIRING TO BE PER LOCAL CODES. USE COPPER CONDUCTORS ONLY.
 2. SEE INSTALLATION AND USER MANUAL(S).
 3. JUMPER TO BE REMOVED WHEN OPTIONAL COMPONENT IS USED.
 4. ALL RJ45/ETHERNET CABLES MUST BE STRAIGHT THROUGH.
 5. 10 DI CARD INSTALLED ON THE FAN PANEL.

NOMENCLATURE			
STANDARD DEVICES	COORD	OPTIONAL DEVICES	COORD
CPSS - CP POWER SUPPLY 24VDC	5.C		
FANPS - FANS POWER SUPPLY 48VDC	5.D		
FBK2 - FUSE BLOCK 2 FANS	6.D		
FBK3 - FUSE BLOCK 3 CP	6.C		

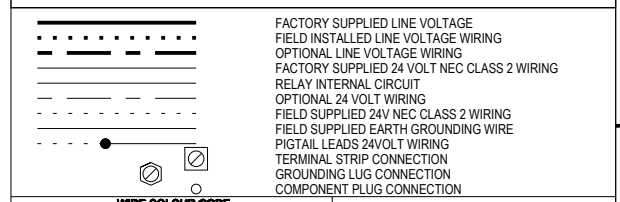

WIRE COLOUR CODE

OG - ORANGE	PR - PURPLE	BL - BLUE
RD - RED	GR - GREEN	BK - BLACK
BN - BROWN	YEL - YELLOW	WH - WHITE



1650 DEARBORN DRIVE, P.O. BOX 29186
COLUMBUS, OHIO 43229

©VERTIV CO.-CONFIDENTIAL AND PROPRIETARY - ALL RIGHTS RESERVED
THIS DOCUMENT (AND THE INFORMATION IT CONTAINS) ARE THE PROPERTY OF VERTIV CO. BY ACCEPTING IT INTO YOUR POSSESSION, YOU AGREE THAT YOU WILL KEEP THIS DOCUMENT, AND ALL INFORMATION CONTAINED HEREIN, IN STRICTEST CONFIDENCE, AND WILL NOT COPY, RE TRANSMIT, USE (EXPECT SOLELY FOR THE BENEFIT OF VERTIV CO.), SELL, LEND OR OTHERWISE DISPOSE OF THE SAME, DIRECTLY OR INDIRECTLY, WITHOUT THE EXPRESS WRITTEN PERMISSION OF VERTIV CO., AND THIS DOCUMENT SHALL BE RETURNED TO VERTIV CO. IMMEDIATELY UPON REQUEST.

ELECTRICAL SCHEMATIC
VERTIV® CRV DX 30kW
208-230V 3PH 50-60HZ
iCOM2 LARGE CONTROL
WITH HUMIDIFIER & REHEAT
HMI TOUCH SCREEN

DRAWN	DATE
P. BELMAREZ	2026/03/24
CHECKED	DATE
A. TORRES	2026/03/24
ENGR	DATE
A. TORRES	2026/03/24

CAGE CODE	
1EDC2	
DRAWING NO	
10080205DRW	
REV	
G	

FANS & CP
SHEET 2 OF 4

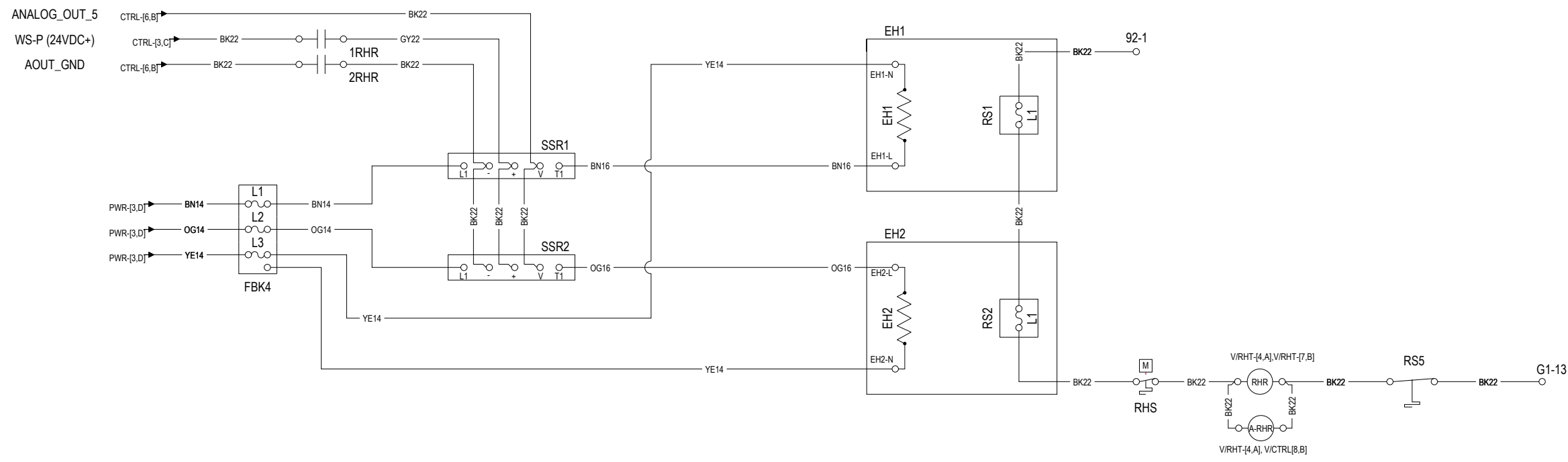
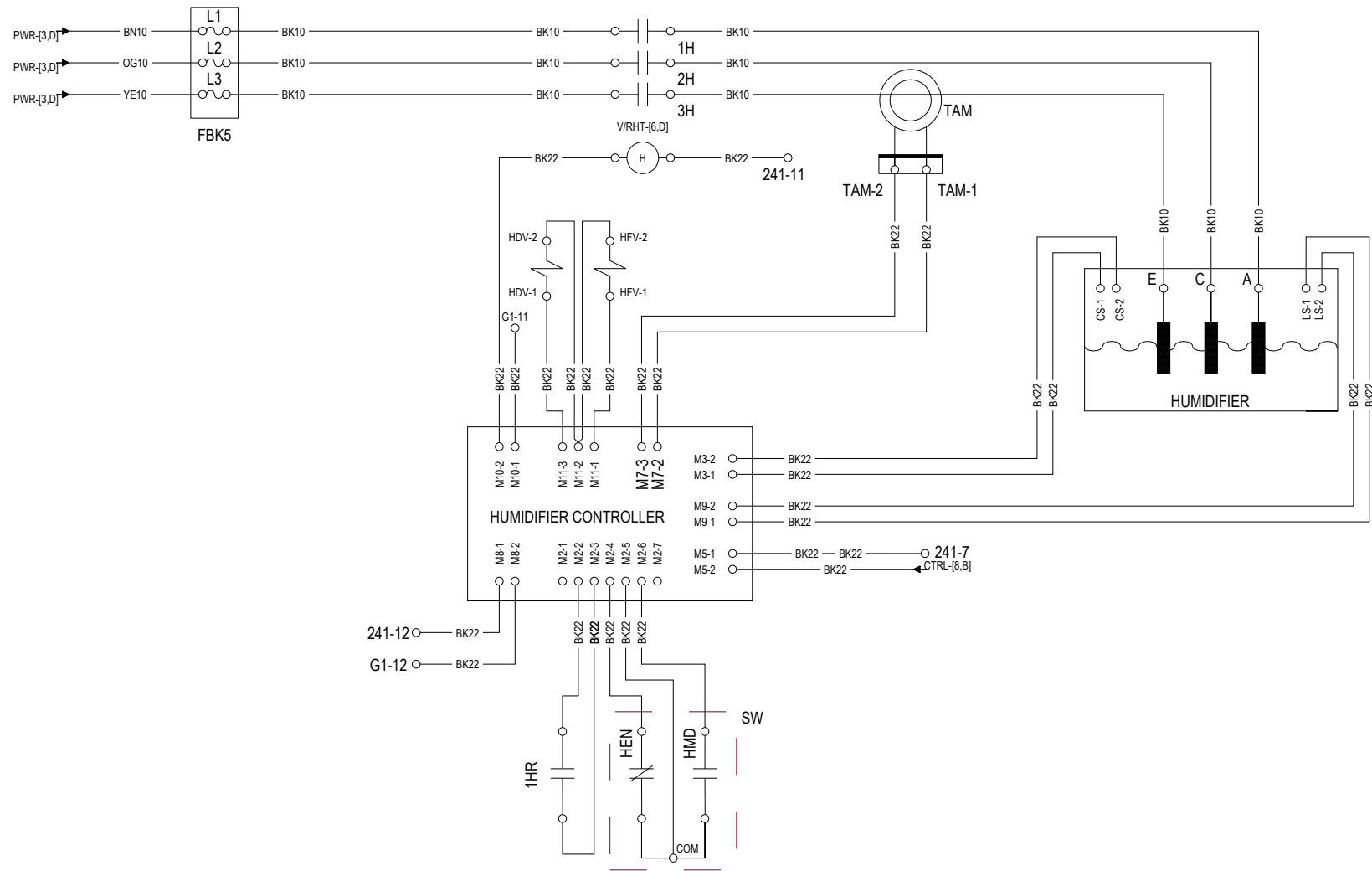

- NOTES:
1. ALL FIELD WIRING TO BE PER LOCAL CODES. USE COPPER CONDUCTORS ONLY.
 2. SEE INSTALLATION AND USER MANUAL(S).
 3. ALL RJ45/ETHERNET CABLES MUST BE STRAIGHT THROUGH.
 4. 10 DI CARD INSTALLED ON THE FAN PANEL.

NOMENCLATURE			
STANDARD DEVICES	COORD	OPTIONAL DEVICES	COORD
EH1 - ELECTRICAL REHEAT 1	5.B		
EH2 - ELECTRICAL REHEAT 2	5.A		
FBK4 - FUSE BLOCK 4 REHEAT	7.A		
FBK5 - FUSE BLOCK 5 HUMIDIFIER	7.D		
H - HUMIDIFIER CONTACTOR	6.D		
HDV - HUMIDIFIER DRAIN VALVE	6.D		
HFV - HUMIDIFIER FILL VALVE	6.D		
RHR - REHEAT RELAY	7.D		
RS5 - THERMAL CUT-OFF SWITCH	6.D		
SSR1 - SOLID STATE RELAY 1	6.B		
SSR2 - SOLID STATE RELAY 2	6.A		
TAM - HUM CURRENT TRANSFORMER	5.D		
A-RHR - AUXILIARY CONTACT RHR			
RS5 - MANUAL RESET THERMAL CUT-OFF SWITCH	4.D		

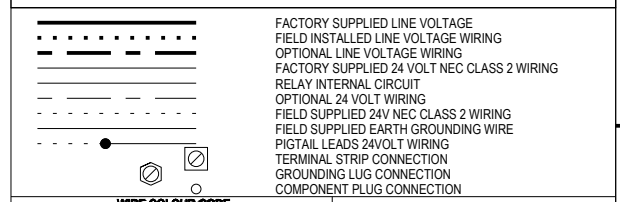

WIRE COLOUR CODE		
OG - ORANGE	PR - PURPLE	BL - BLUE
RD - RED	GR - GREEN	BK - BLACK
BN - BROWN	YEL - YELLOW	WH - WHITE



1650 DEARBORN DRIVE, P.O. BOX 29186
COLUMBUS, OHIO 43229

©VERTIV CO.-CONFIDENTIAL AND PROPRIETARY - ALL RIGHTS RESERVED
THIS DOCUMENT (AND THE INFORMATION IT CONTAINS) ARE THE PROPERTY OF VERTIV CO. BY ACCEPTING IT INTO YOUR POSSESSION, YOU AGREE THAT YOU WILL KEEP THIS DOCUMENT, AND ALL INFORMATION CONTAINED HEREIN, IN STRICTEST CONFIDENCE, AND WILL NOT COPY, REPRODUCE, TRANSMIT, USE (EXPECT SOLELY FOR THE BENEFIT OF VERTIV CO.), SELL, LEND OR OTHERWISE DISPOSE OF THE SAME, DIRECTLY OR INDIRECTLY, WITHOUT THE EXPRESS WRITTEN PERMISSION OF VERTIV CO. AND THIS DOCUMENT SHALL BE RETURNED TO VERTIV CO. IMMEDIATELY UPON REQUEST.

ELECTRICAL SCHEMATIC
VERTIV® CRV DX 30kW
208-230V 3PH 50-60HZ
iCOM2 LARGE CONTROL
WITH HUMIDIFIER & REHEAT
HMI TOUCH SCREEN

DRAWN P. BELMAREZ	DATE 2026/03/24
CHECKED A. TORRES	DATE 2026/03/24
ENGR A. TORRES	DATE 2026/03/24

DRAWING NO 10080205DRW	REV G
---------------------------	----------

REHEAT & HUMIDIFIER
SHEET 4 OF 4

LINE VOLTAGE
1 PHASE SUPPLY (A)

SEE UNIT NAMEPLATE
FOR MAIN SUPPLY
WIRE SIZING

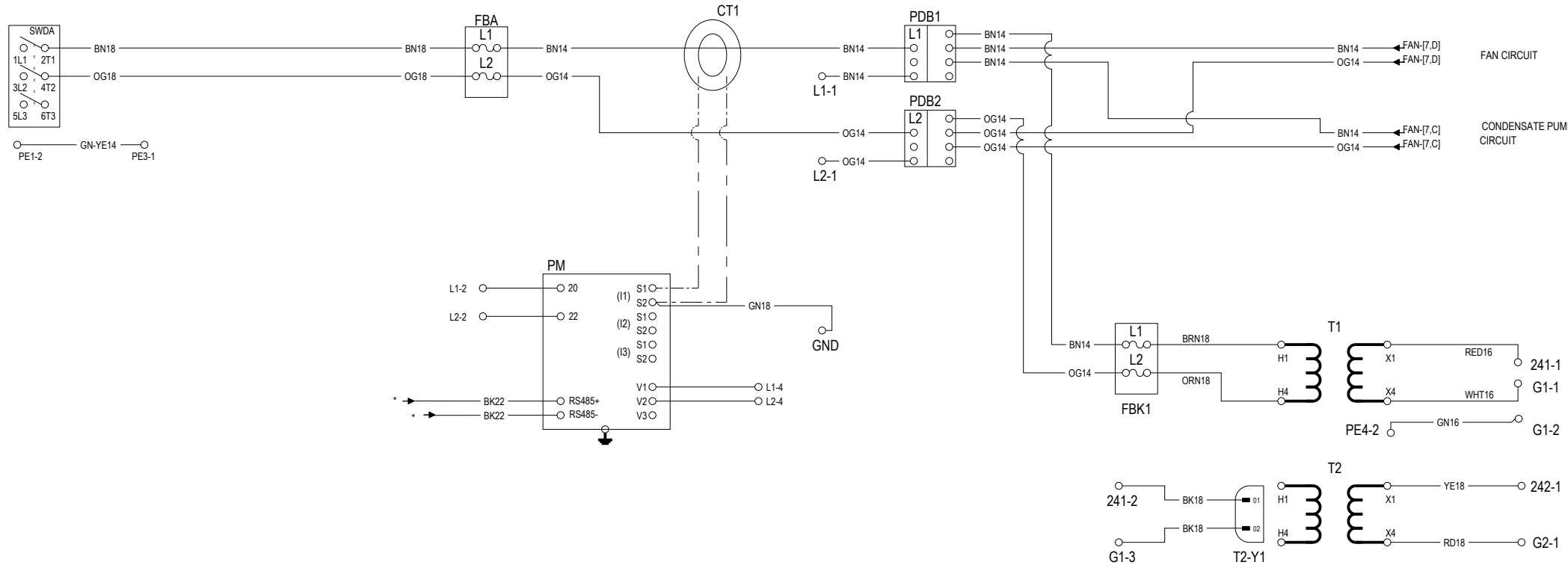

- NOTES:
1. ALL FIELD WIRING TO BE PER LOCAL CODES. USE COPPER CONDUCTORS ONLY.
 2. SEE INSTALLATION AND USER MANUAL(S).
 3. JUMPER TO BE REMOVED WHEN OPTIONAL COMPONENT IS USED.
 4. ALL RJ45/ETHERNET CABLES MUST BE STRAIGHT THROUGH.
 5. 10 DI CARD INSTALLED ON THE FAN PANEL.

NOMENCLATURE			
STANDARD DEVICES	COORD	OPTIONAL DEVICES	COORD
FBA - FUSE BLOCK A	6.D	CT1 - CURRENT TRANSFORMER 1	5.D
FBB - FUSE BLOCK B	6.D	CT2 - CURRENT TRANSFORMER 2	5.D
FBK1 - FUSE BLOCK 1 CONTROL	4.C	PM - POWER METER	6.C
KA1 - RELAY ATS FEEDBACK	7.D		
KMA - CONTACTOR ATS A	7.D		
PDB1 - POWER DIST BLOCK L1	5.D		
PDB2 - POWER DIST BLOCK L2	5.D		
SWDA - SWITCH DISCONNECT A	8.D		
SWDB - SWITCH DISCONNECT B	8.D		
T1 - CONTROL TRANSFORMER	3.C		
T2 - ISOLATION TRANSFORMER	3.C		

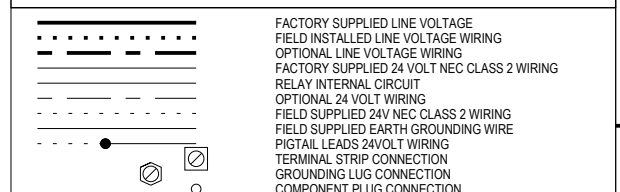

WIRE COLOUR CODE		
OG - ORANGE	PR - PURPLE	BL - BLUE
RD - RED	GR - GREEN	BK - BLACK
BN - BROWN	YEL - YELLOW	WH - WHITE

1650 DEARBORN DRIVE, P.O. BOX 29186
COLUMBUS, OHIO 43229

CAGE CODE
1EDC2

©VERTIV CO.-CONFIDENTIAL AND PROPRIETARY - ALL RIGHTS RESERVED
THIS DOCUMENT (AND THE INFORMATION IT CONTAINS) ARE THE PROPERTY OF VERTIV CO. BY ACCEPTING IT INTO YOUR POSSESSION, YOU AGREE THAT YOU WILL KEEP THIS DOCUMENT, AND ALL INFORMATION CONTAINED HEREIN, IN STRICTEST CONFIDENCE, AND WILL NOT COPY, RE TRANSMIT, USE (EXPECT SOLELY FOR THE BENEFIT OF VERTIV CO.), SELL, LEND OR OTHERWISE DISPOSE OF THE SAME, DIRECTLY OR INDIRECTLY, WITHOUT THE EXPRESS WRITTEN PERMISSION OF VERTIV CO., AND THIS DOCUMENT SHALL BE RETURNED TO VERTIV CO. IMMEDIATELY UPON REQUEST.

VERTIV

ELECTRICAL SCHEMATIC
VERTIV® CRV DX 40kW
208-230V 1PH 50-60HZ
iCOM2 LARGE CONTROL
W/O HUMIDIFIER & REHEAT
HMI TOUCH SCREEN

POWER SUPPLY

SHEET 1 OF 3

DRAWN	P. BELMAREZ	DATE	2026/03/30
CHECKED	A. TORRES	DATE	2026/03/30
ENGR	A. TORRES	DATE	2026/03/30

DRAWING NO
10080206DRW

REV
G

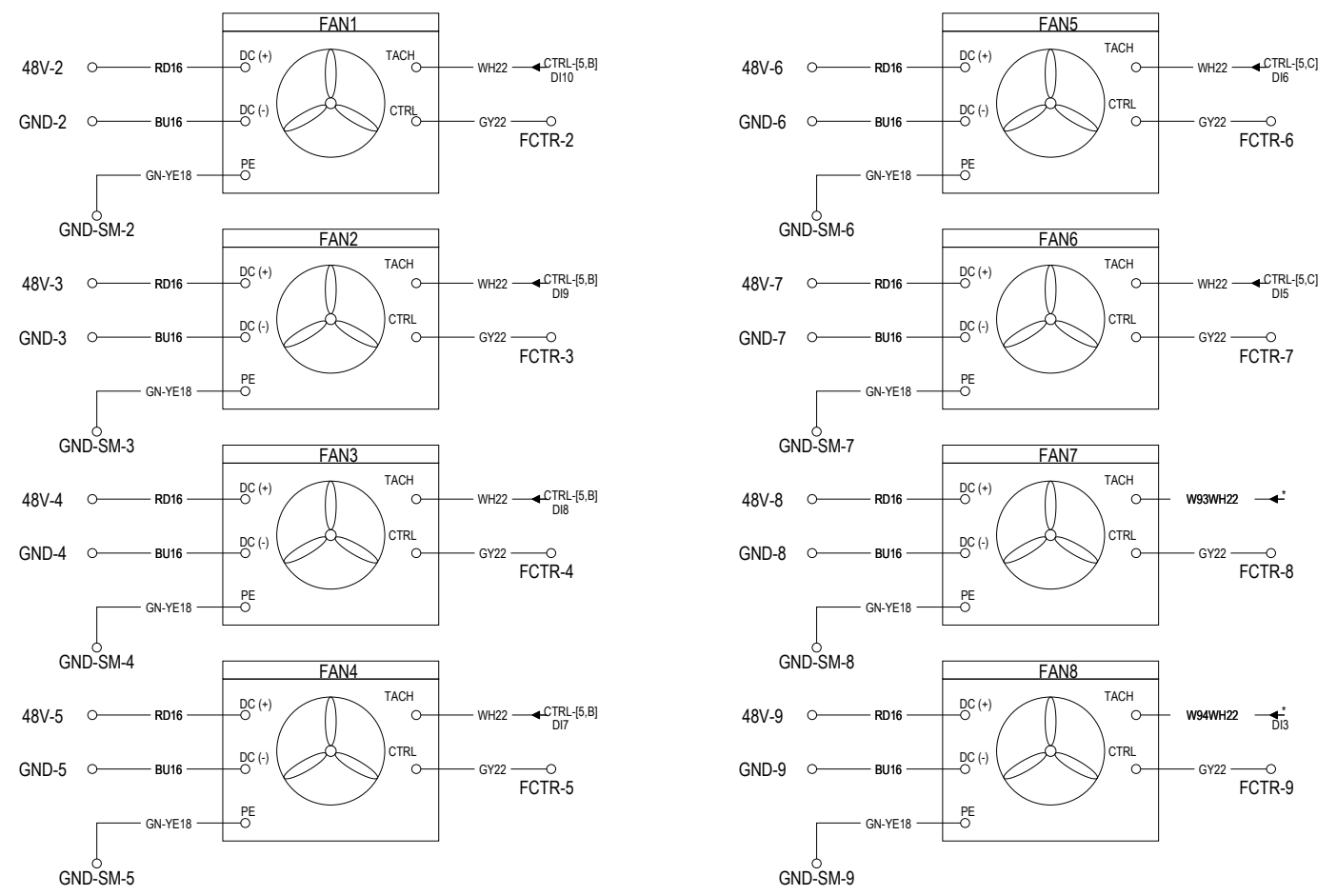
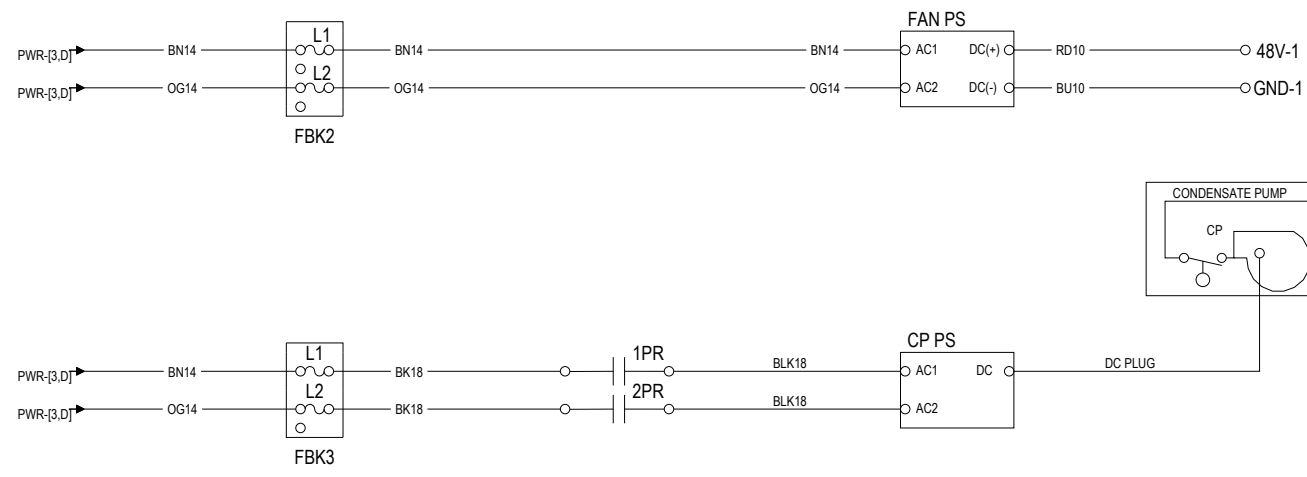

- NOTES:
1. ALL FIELD WIRING TO BE PER LOCAL CODES. USE COPPER CONDUCTORS ONLY.
 2. SEE INSTALLATION AND USER MANUAL(S).
 3. JUMPER TO BE REMOVED WHEN OPTIONAL COMPONENT IS USED.
 4. ALL RJ45/ETHERNET CABLES MUST BE STRAIGHT THROUGH.
 5. 10 DI CARD INSTALLED ON THE FAN PANEL.

NOMENCLATURE			
STANDARD DEVICES	COORD	OPTIONAL DEVICES	COORD
CPPS - CP POWER SUPPLY 24VDC	5.C		
FANPS - FANS POWER SUPPLY 48VDC	5.D		
FBK2 - FUSE BLOCK 2 FANS	6.D		
FBK3 - FUSE BLOCK 3 CP	6.C		

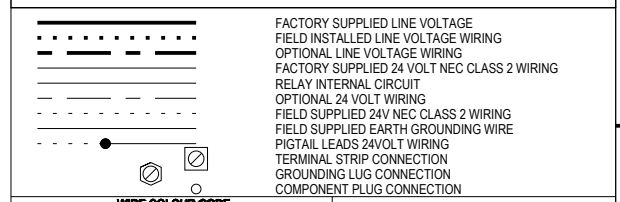

WIRE COLOUR CODE		
OG - ORANGE	PR - PURPLE	BL - BLUE
RD - RED	GR - GREEN	BK - BLACK
BN - BROWN	YEL - YELLOW	WH - WHITE



1650 DEARBORN DRIVE, P.O. BOX 29186
COLUMBUS, OHIO 43229

CAGE CODE
1EDC2

©VERTIV CO.-CONFIDENTIAL AND PROPRIETARY - ALL RIGHTS RESERVED
THIS DOCUMENT (AND THE INFORMATION IT CONTAINS) ARE THE PROPERTY OF VERTIV CO. BY ACCEPTING IT INTO YOUR POSSESSION, YOU AGREE THAT YOU WILL KEEP THIS DOCUMENT, AND ALL INFORMATION CONTAINED HEREIN, IN STRICTEST CONFIDENCE, AND WILL NOT COPY, RE TRANSMIT, USE (EXPECT SOLELY FOR THE BENEFIT OF VERTIV CO.), SELL, LEND OR OTHERWISE DISPOSE OF THE SAME, DIRECTLY OR INDIRECTLY, WITHOUT THE EXPRESS WRITTEN PERMISSION OF VERTIV CO., AND THIS DOCUMENT SHALL BE RETURNED TO VERTIV CO. IMMEDIATELY UPON REQUEST.

ELECTRICAL SCHEMATIC
VERTIV® CRV DX 40kW
208-230V 1PH 50-60HZ
iCOM2 LARGE CONTROL
W/O HUMIDIFIER & REHEAT
HMI TOUCH SCREEN

DRAWN	P. BELMAREZ	DATE	2026/03/30
CHECKED	A. TORRES	DATE	2026/03/30
ENGR	A. TORRES	DATE	2026/03/30

DRAWING NO	10080206DRW	REV	G
SHEET 2 OF 3			

LINE VOLTAGE
1 PHASE SUPPLY (A)

SEE UNIT NAMEPLATE
FOR MAIN SUPPLY
WIRE SIZING

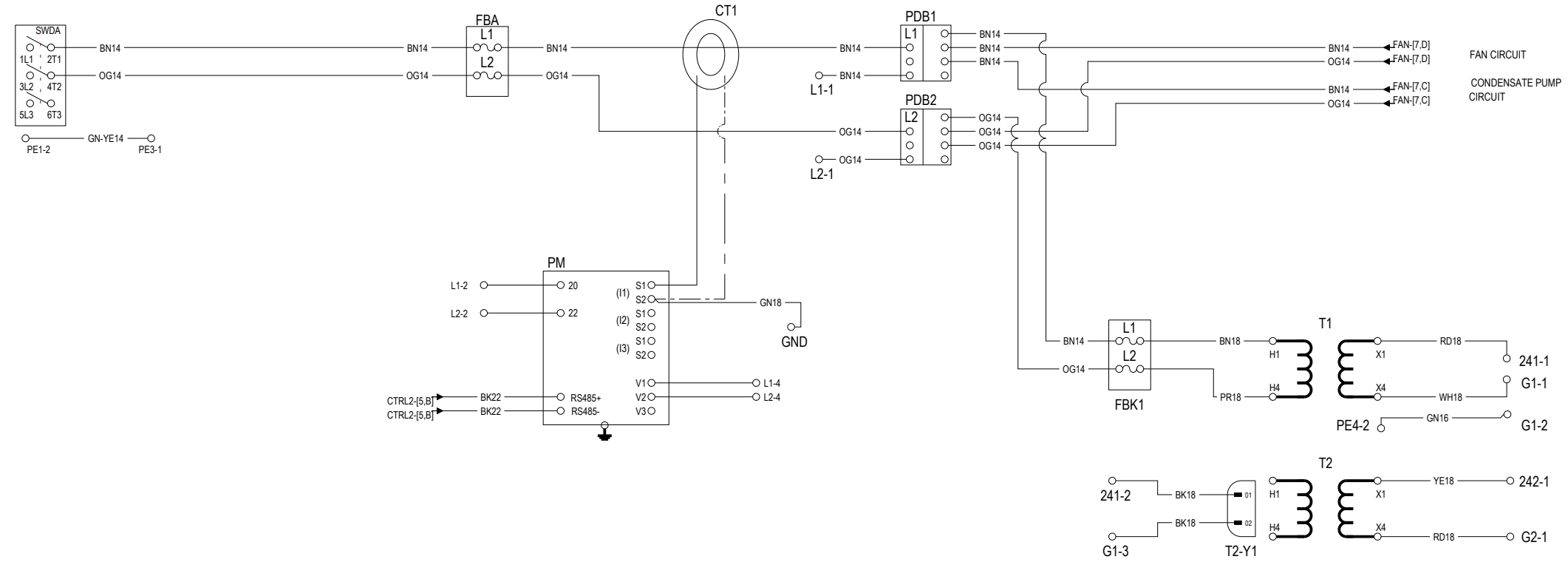

- NOTES:
1. ALL FIELD WIRING TO BE PER LOCAL CODES. USE COPPER CONDUCTORS ONLY.
 2. SEE INSTALLATION AND USER MANUAL(S).
 3. JUMPER TO BE REMOVED WHEN OPTIONAL COMPONENT IS USED.
 4. ALL RJ45/ETHERNET CABLES MUST BE STRAIGHT THROUGH.
 5. 10 DI CARD INSTALLED ON THE FAN PANEL.

NOMENCLATURE			
STANDARD DEVICES	COORD	OPTIONAL DEVICES	COORD
FBA - FUSE BLOCK A	6.D	CT1 - CURRENT TRANSFORMER 1	5.D
FBB - FUSE BLOCK B	6.D	CT2 - CURRENT TRANSFORMER 2	5.D
FBK1 - FUSE BLOCK 1 CONTROL	4.C	PM - POWER METER	6.C
KA1 - RELAY ATS FEEDBACK	7.D		
KMA - CONTACTOR ATS A	7.D		
PDB1 - POWER DIST BLOCK L1	5.D		
PDB2 - POWER DIST BLOCK L2	5.D		
SWDA - SWITCH DISCONNECT A	8.D		
SWDB - SWITCH DISCONNECT B	8.D		
T1 - CONTROL TRANSFORMER	3.C		
T2 - ISOLATION TRANSFORMER	3.C		

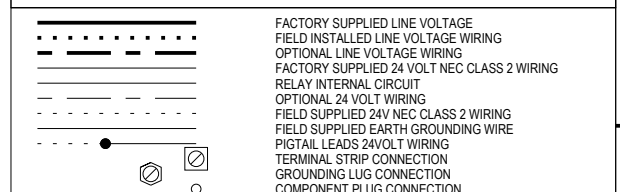

WIRE COLOUR CODE		
OG - ORANGE	PR - PURPLE	BL - BLUE
RD - RED	GR - GREEN	BK - BLACK
BN - BROWN	YEL - YELLOW	WH - WHITE

1650 DEARBORN DRIVE, P.O. BOX 29186
COLUMBUS, OHIO 43229

CAGE CODE
1EDC2

©VERTIV CO.-CONFIDENTIAL AND PROPRIETARY - ALL RIGHTS RESERVED
THIS DOCUMENT (AND THE INFORMATION IT CONTAINS) ARE THE PROPERTY OF VERTIV CO. BY ACCEPTING IT INTO YOUR POSSESSION, YOU AGREE THAT YOU WILL KEEP THIS DOCUMENT, AND ALL INFORMATION CONTAINED HEREIN, IN STRICTEST CONFIDENCE, AND WILL NOT COPY, RE TRANSMIT, USE (EXPECT SOLELY FOR THE BENEFIT OF VERTIV CO.), SELL, LEND OR OTHERWISE DISPOSE OF THE SAME, DIRECTLY OR INDIRECTLY, WITHOUT THE EXPRESS WRITTEN PERMISSION OF VERTIV CO., AND THIS DOCUMENT SHALL BE RETURNED TO VERTIV CO. IMMEDIATELY UPON REQUEST.

VERTIV

DRAWN	P. BELMAREZ	DATE	2026/03/30
CHECKED	A. TORRES	DATE	2026/03/30
ENGR	P. BELMAREZ	DATE	2026/03/30

ELECTRICAL SCHEMATIC

VERTIV® CRV DX 30KW
208-230V 1PH 50-60HZ
iCOM2 LARGE CONTROL
W/O HUMIDIFIER & REHEAT
HMI TOUCH SCREEN

POWER SUPPLY

SHEET 1 OF 3

DRAWING NO
10080207DRW

REV
H

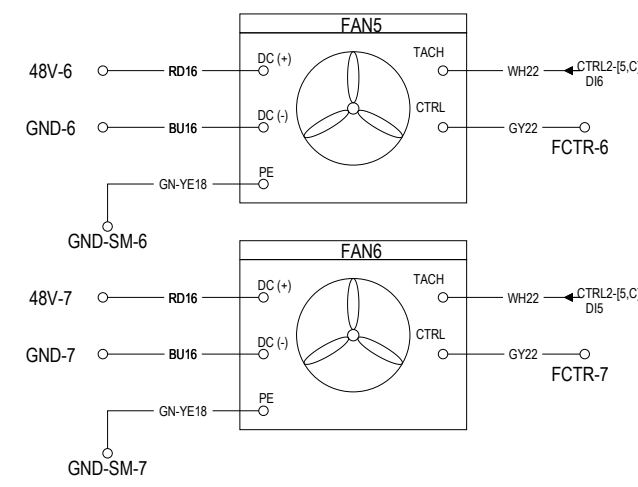
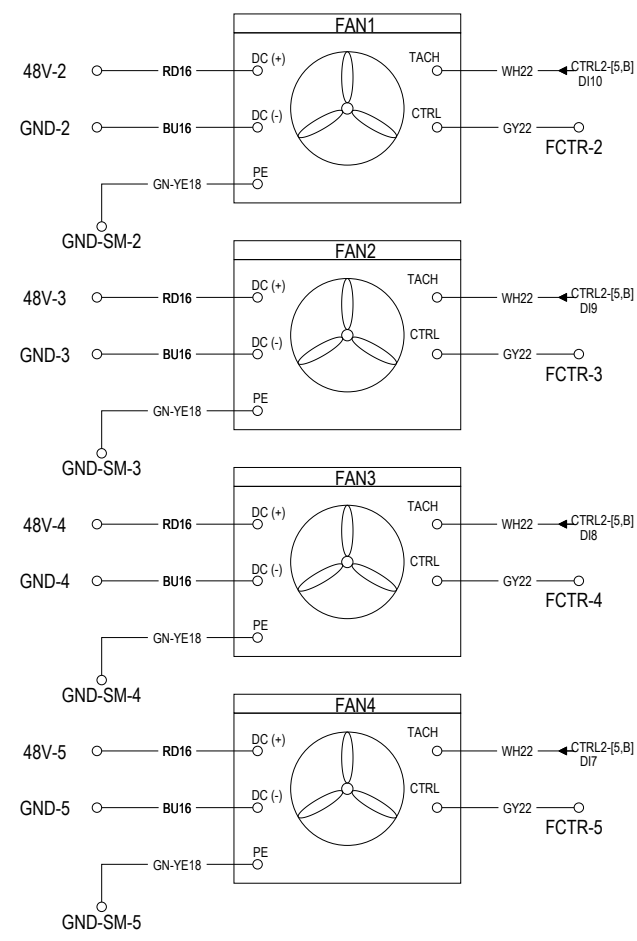
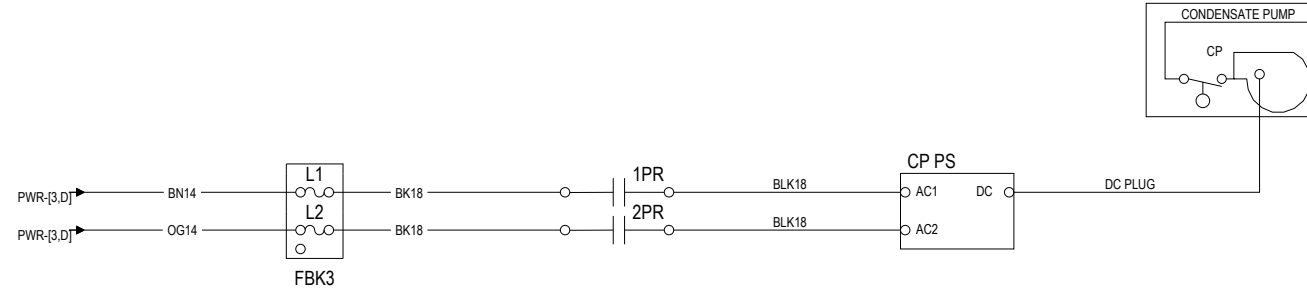
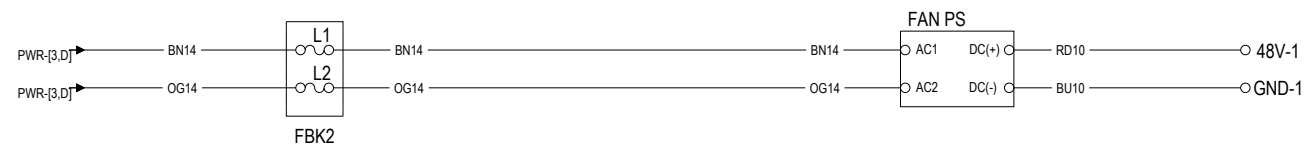

- NOTES:
1. ALL FIELD WIRING TO BE PER LOCAL CODES. USE COPPER CONDUCTORS ONLY.
 2. SEE INSTALLATION AND USER MANUAL(S).
 3. JUMPER TO BE REMOVED WHEN OPTIONAL COMPONENT IS USED.
 4. ALL RJ45/ETHERNET CABLES MUST BE STRAIGHT THROUGH.
 5. 10 DI CARD INSTALLED ON THE FAN PANEL.

NOMENCLATURE			
STANDARD DEVICES	COORD	OPTIONAL DEVICES	COORD
CPPS - CP POWER SUPPLY 24VDC	5.C		
FANPS - FANS POWER SUPPLY 48VDC	5.D		
FBK2 - FUSE BLOCK 2 FANS	6.D		
FBK3 - FUSE BLOCK 3 CP	6.C		

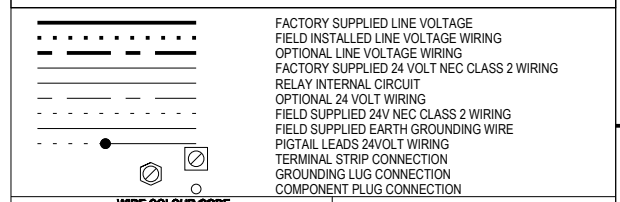

WIRE COLOUR CODE

OG - ORANGE	PR - PURPLE	BL - BLUE
RD - RED	GR - GREEN	BK - BLACK
BN - BROWN	YEL - YELLOW	WH - WHITE

1650 DEARBORN DRIVE, P.O. BOX 29186
COLUMBUS, OHIO 43229

CAGE CODE
1EDC2



©VERTIV CO.-CONFIDENTIAL AND PROPRIETARY - ALL RIGHTS RESERVED
THIS DOCUMENT (AND THE INFORMATION IT CONTAINS) ARE THE PROPERTY OF VERTIV CO. BY ACCEPTING IT INTO YOUR POSSESSION, YOU AGREE THAT YOU WILL KEEP THIS DOCUMENT, AND ALL INFORMATION CONTAINED HEREIN, IN STRICTEST CONFIDENCE, AND WILL NOT COPY, RE TRANSMIT, USE (EXPECT SOLELY FOR THE BENEFIT OF VERTIV CO.), SELL, LEND OR OTHERWISE DISPOSE OF THE SAME, DIRECTLY OR INDIRECTLY, WITHOUT THE EXPRESS WRITTEN PERMISSION OF VERTIV CO., AND THIS DOCUMENT SHALL BE RETURNED TO VERTIV CO. IMMEDIATELY UPON REQUEST.

ELECTRICAL SCHEMATIC
VERTIV® CRV DX 30KW
208-230V 1PH 50-60HZ
iCOM2 LARGE CONTROL
W/O HUMIDIFIER & REHEAT
HMI TOUCH SCREEN

DRAWN	DATE
P. BELMAREZ	2026/03/30
CHECKED	DATE
A. TORRES	2026/03/30
ENGR	DATE
P. BELMAREZ	2026/03/30

FANS & CP	
SHEET 2 OF 3	
DRAWING NO	REV
10080207DRW	H

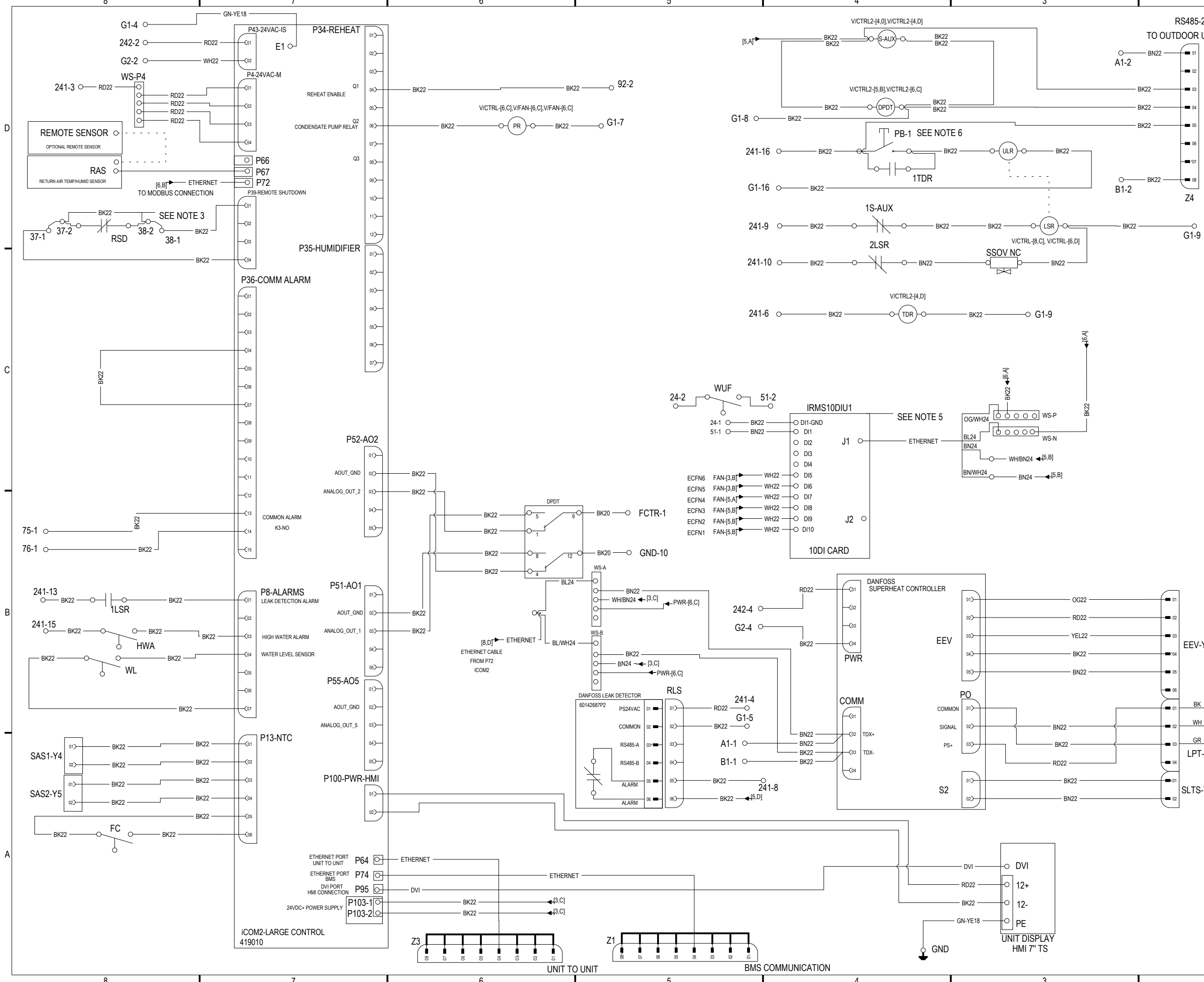

- NOTES:
1. ALL FIELD WIRING TO BE PER LOCAL CODES. USE COPPER CONDUCTORS ONLY.
 2. SEE INSTALLATION AND USER MANUAL(S).
 3. JUMPER TO BE REMOVED WHEN OPTIONAL COMPONENT IS USED.
 4. ALL RJ45/ETHERNET CABLES MUST BE STRAIGHT THROUGH.
 5. 10 DI CARD INSTALLED ON THE FAN PANEL.
 6. PUSH BUTTON IS FOR RESETING THE UNIT AFTER A REFRIGERANT LEAK IS REMEDIATED.

NOMENCLATURE			
STANDARD DEVICES	COORD	OPTIONAL DEVICES	COORD
EEV - ELECTRONIC EXP VALVE	3.A	RSD - REMOTE SHUTDOWN DEVICE	8.C
FC - FILTER CLOG SWITCH	8.C	SSOV - SAFETY SHUT-OFF VALVE	5.D
HR - HUMIDIFIER RELAY	6.C	WUF - WATER UNDER FLOOR	8.A
HWA - HIGH WATER ALARM	8.D		
LPT - LOW PRESSURE TRANSDUCER	3.A		
LSR - LEAK SENSOR RELAY	6.D		
PR - CONDENSATE PUMP RELAY	6.C		
RLS - REFRIGERANT LEAK SENSOR	6.A		
SAS1-4 - SUPPLY AIR SENSORS 1-4	8.B		
SLTS - SUCTION LINE TEMP SENSOR	3.A		
WL - WATER LEVEL SENSOR	8.C		
ULR - UNLATCHING RELAY	3.D		
TDR - TIME DELAY RELAY	4.D		

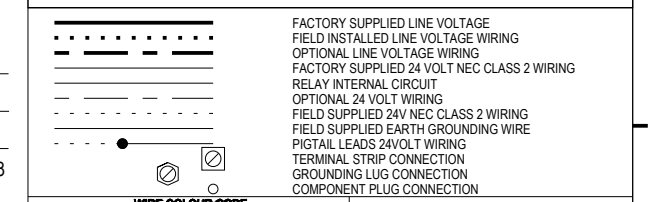

WIRE COLOUR CODE		
OG - ORANGE	PR - PURPLE	BL - BLUE
RD - RED	GR - GREEN	BK - BLACK
BN - BROWN	YEL - YELLOW	WH - WHITE

1650 DEARBORN DRIVE, P.O. BOX 29186
COLUMBUS, OHIO 43229

CAGE CODE
1EDC2

©VERTIV CO.-CONFIDENTIAL AND PROPRIETARY - ALL RIGHTS RESERVED
THIS DOCUMENT AND THE INFORMATION IT CONTAINS ARE THE PROPERTY OF VERTIV CO. BY ACCEPTING IT INTO YOUR POSSESSION, YOU AGREE THAT YOU WILL KEEP THIS DOCUMENT, AND ALL INFORMATION CONTAINED HEREIN, IN STRICTEST CONFIDENCE, AND WILL NOT COPY, REPRODUCE, TRANSMIT, USE (EXPECT SOLELY FOR THE BENEFIT OF VERTIV CO.), SELL, LEND OR OTHERWISE DISPOSE OF THE SAME, DIRECTLY OR INDIRECTLY, WITHOUT THE EXPRESS WRITTEN PERMISSION OF VERTIV CO., AND THIS DOCUMENT SHALL BE RETURNED TO VERTIV CO. IMMEDIATELY UPON REQUEST.

ELECTRICAL SCHEMATIC
VERTIV® CRV DX 30kW
208-230V 1PH 50-60HZ
iCOM2 LARGE CONTROL
W/O HUMIDIFIER & REHEAT
HMI TOUCH SCREEN

DRAWN	DATE	CHECKED	DATE	ENGR	DATE	DRAWING NO	REV
P. BELMAREZ	2026/03/30	A. TORRES	2026/03/30	P. BELMAREZ	2026/03/30	10080207DRW	H

SHEET 3 OF 3
CONTROL

VERTIV PN	LENGTH	MANUFACTURER	MFG PN	DESCRIPTION
10159904P2	15000mm	TRIPP-LITE	P560-050	CBL M-M DVI-D DUAL LINK 50' SHLD

CO NO	REV	DESCRIPTION	DRAWN BY:	DATE
CO-1114550	A	PRODUCTION RELEASE	A.TORRES	06/09/2025
			D. MACIEL	06/09/2025

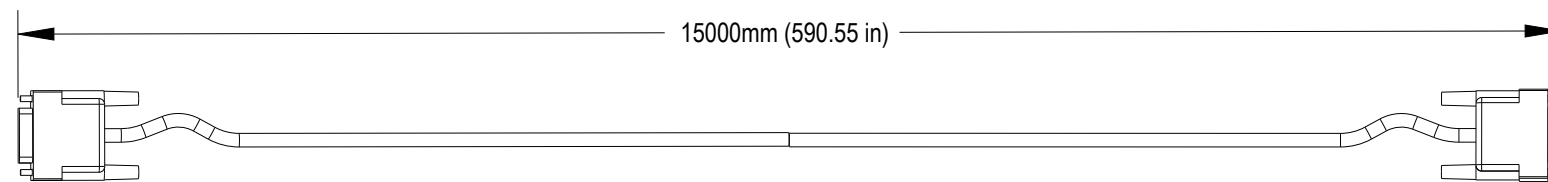

CORPORATE CAGE CODE 1EDC2	505 N. CLEVELAND AVE WESTERVILLE, OHIO 43082	10159904P2 PART NUMBER	CBL M-M DVI-D DUAL LINK 50' SHLD DESCRIPTION
<small>© 2024 VERTIV GROUP CORP. CONFIDENTIAL AND PROPRIETARY. ALL RIGHTS RESERVED. VERTIV AND THE VERTIV LOGO ARE TRADEMARKS OR REGISTERED TRADEMARKS OF VERTIV GROUP CORP. THIS DOCUMENT (AND THE INFORMATION IT CONTAINS) ARE THE PROPERTY OF VERTIV GROUP CORP. BY ACCEPTING IT INTO YOUR POSSESSION, YOU AGREE THAT YOU WILL KEEP THIS DOCUMENT AND ALL INFORMATION CONTAINED HEREIN IN STRICTEST CONFIDENCE AND WILL NOT COPY, RETRANSMIT USE (EXCEPT SOLELY FOR THE BENEFIT OF VERTIV GROUP CORP.), SELL, LEND, OR OTHERWISE DISPOSE OF SAME, DIRECTLY OR INDIRECTLY, WITHOUT THE EXPRESS WRITTEN PERMISSION OF VERTIV GROUP CORP., AND THIS DOCUMENT SHALL BE RETURNED TO VERTIV GROUP CORP. IMMEDIATELY UPON REQUEST.</small>			
MATERIAL: NONE	UNLESS OTHERWISE SPECIFIED TOLERANCE		
FINISH: NONE	MM (PRIMARY)	INCHES (SECONDARY)	
	X ±2 (X) ±.1	XX ±.8 (XX) ±.03	
	XX ±.38 (XXX) ±.015	HOLE DIA ±0.13 HOLE DIA ±.005	
DESIGNED BY: A.TORRES	DATE: 06/09/2025	WEIGHT: -	CONTROL CHARACTERISTICS PART DESCRIPTION CBL M-M DVI-D DUAL LINK 50' SHLD
DRAWN BY: A.TORRES	DATE: 06/09/2025	SHEET: 1/1	THIRD ANGLE PROJECTION SIZE B SCALE 1:1 DOCUMENT NUMBER 10159904P2DRW REV A



DX PRODUCTS WITH R32

A2L REFRIGERANT DISPERSAL VOLUME CALCULATION R32

Engineer of record to determine the Refrigerant Charge m_c and required minimum Effective Dispersal Volume V_{ED} of the space to which the appliance can be utilized for the cooling of ITE AREAS.

The required minimum EFFECTIVE DISPERSAL VOLUME V_{ED} is a function of the refrigerant charge, m_c and is represented by the following equation:

$$V_{ED} = m_c / 0.5 \times \text{LFL}$$

V_{ED} = the minimum Effective Dispersal Volume in ft^3 (m^3)

m_c = the refrigerant charge of the largest single circuit of a unit in lbs (kg)

0.5 = the concentration factor

LFL = the Lower Flammability Limit in $\text{lbs}/1000 \text{ft}^3$ (kg/m^3)

Note: The LFL of R32 is $19.2 \text{ lbs}/1000 \text{ft}^3$ ($307.0 \text{ g}/\text{m}^3$) according to ASHRAE 34-2022.

Minimum Effective Dispersal Volume V_{ED} of the space shall be based on altitude of the installation location. For locations above sea level, the engineer of record will need to adjust the value of LFL in accordance with ANSI/ASHRAE 34 before applying it to the equation for determining the required minimum Effective Dispersal Volume V_{ED} .

Charge Size vs. Effective Dispersal Volume

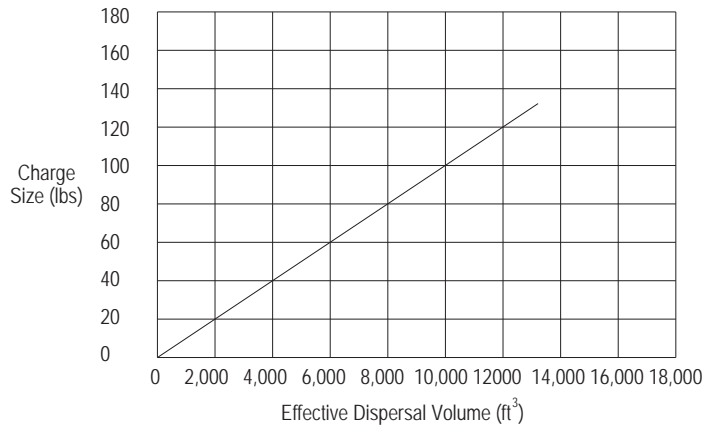

Charge Size vs. Effective Dispersal Volume

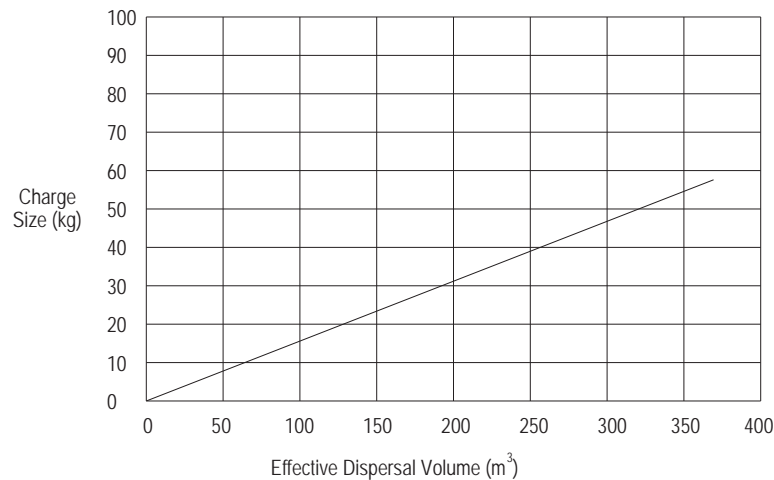



DX PRODUCTS WITH R32

A2L REFRIGERANT DISPERSAL VOLUME CALCULATION R32

How to Determine the Effective Dispersal Volume of an ITE Area

Volume Calculations shall be based on the overall volume of space available to which the refrigerant disperses within the CIRCULATION AIRFLOW in the event of a refrigerant leak. This overall volume shall be modified with the appropriate deductions. For the purposes of determining the EFFECTIVE DISPERSAL VOLUME of an ITE AREA the following shall apply:

- a) The EFFECTIVE DISPERSAL VOLUME shall only include the circulated airflow of the system.
- b) The EFFECTIVE DISPERSAL VOLUME shall initially include the ITE AREA enclosed by the floor, walls, and ceiling of that space.
- c) When the CIRCULATION AIRFLOW includes underfloor spaces, suspended ceiling spaces, or other partitioned spaces, such as equipment galleries, the volume of those spaces may be included.

In general, the volume of equipment, piping, wiring, or other apparatus that consume space within and are isolated from the CIRCULATION AIRFLOW shall be deducted from the EFFECTIVE DISPERSAL VOLUME. The following deductions shall be applied:

- a) When the CIRCULATION AIRFLOW has been fully contained on both hot and cold sides of the aisle, via ducts or other apparatus, any room volume outside of that containment shall not be included when calculating the EFFECTIVE DISPERSAL VOLUME.
- b) When the overall volume of space available, or a partitioned portion of that volume includes ducted openings from partially ducted systems, some volume of that space may require a deduction. No volume greater than 4 feet away in height from the upper most supply or return duct opening in the space may be included when calculating the EFFECTIVE DISPERSAL VOLUME, unless an analysis of the airflow has been conducted to show that the volume of air has effective movement for the mixing of a leaked refrigerant.
- c) Obstructions of tubing, piping, wiring, etc., consuming more than 0.0071 m^3 (0.25 ft^3) of space shall be included in the deductions from the overall volume.
- d) The ITE within the circulated airflow shall be evaluated for their deduction from the EFFECTIVE DISPERSAL VOLUME. The deducted volume of the ITE shall be based on the designed maximum capacity or fill of the servers.
- e) As a maximum value, no more than 75 % of the ITE's volume shall be included as circulating air space in the EFFECTIVE DISPERSAL VOLUME. The total volume of the ITE shall be defined by the overall dimensions of its ITE ENCLOSURE. Small gaps in between individual server racks shall not be included in the EFFECTIVE DISPERSAL VOLUME.
- f) Any other volume within the circulation airflow that is otherwise enclosed or partitioned off from the airflow shall be deducted in the calculation of the EFFECTIVE DISPERSAL VOLUME.

Connect with Vertiv on Social Media



<https://www.facebook.com/vertiv/>



<https://www.instagram.com/vertiv/>



<https://www.linkedin.com/company/vertiv/>



<https://www.x.com/Vertiv/>



Vertiv.com | Vertiv Headquarters, 505 N Cleveland Ave, Westerville, OH 43082 USA

©2026 Vertiv Group Corp. All rights reserved. Vertiv™ and the Vertiv logo are trademarks or registered trademarks of Vertiv Group Corp. All other names and logos referred to are trade names, trademarks or registered trademarks of their respective owners. While every precaution has been taken to ensure accuracy and completeness here, Vertiv Group Corp. assumes no responsibility, and disclaims all liability, for damages resulting from use of this information or for any errors or omissions.

SL-80064_REVB_04-26