



# NetSure™ Inverter System

## Installation Manual

Specification Number: 584130100

The information contained in this document is subject to change without notice and may not be suitable for all applications. While every precaution has been taken to ensure the accuracy and completeness of this document, Vertiv assumes no responsibility and disclaims all liability for damages resulting from use of this information or for any errors or omissions. Refer to other local practices or building codes as applicable for the correct methods, tools, and materials to be used in performing procedures not specifically described in this document.

The products covered by this instruction manual are manufactured and/or sold by Vertiv. This document is the property of Vertiv and contains confidential and proprietary information owned by Vertiv. Any copying, use or disclosure of it without the written permission of Vertiv is strictly prohibited.

Names of companies and products are trademarks or registered trademarks of the respective companies. Any questions regarding usage of trademark names should be directed to the original manufacturer.

### **Technical Support Site**

If you encounter any installation or operational issues with your product, check the pertinent section of this manual to see if the issue can be resolved by following outlined procedures.

Visit <https://www.vertiv.com/support/> for additional assistance.

## TABLE OF CONTENTS

<b>Admonishments Used in this Document</b> .....	<b>iv</b>
<b>Important Safety Instructions</b> .....	<b>v</b>
Safety Admonishments Definitions.....	v
Safety and Regulatory Statements.....	v
Déclarations de Sécurité et de Réglementation.....	v
<b>1 Customer Documentation Package</b> .....	<b>1</b>
<b>2 Installation Acceptance Checklist</b> .....	<b>2</b>
<b>3 Installing the System</b> .....	<b>3</b>
3.1 General Requirements.....	3
3.2 Securing the System to a Relay Rack or a Cabinet Equipment Rack.....	3
<b>4 Setting Switches</b> .....	<b>4</b>
4.1 Switch Setting on IB2 Controller Interface Board.....	4
<b>5 Making Electrical Connections</b> .....	<b>5</b>
5.1 Important Safety Instructions.....	5
5.2 Wiring Considerations.....	5
5.3 Relay Rack / Cabinet Frame Grounding Connection.....	6
5.4 System Shelves Frame Grounding Connections.....	7
5.5 Nominal 120 VAC Input and Equipment Grounding Connections (Spec. No. 584130100 Lists 01, 01E, 02, 02E, 03, 03E, 04, 04E, 06, 06E, 07, and 08 - does NOT apply to Lists 05 and 05E).....	8
5.6 Nominal -48 VDC Input Connections.....	10
5.7 AC Neutral Reference Point (When DC Input Source Only Connected).....	14
5.8 Nominal 120 VAC Output Connections.....	16
5.8.1 List 01, 01E, 03, 03E, 05, and 05E (bulk output).....	16
5.8.2 List 02, 02E, 04, 04E, 06, 06E, 07, and 08 (NEMA output).....	16
5.9 External Alarm, Reference, Monitoring, and Control Connections.....	19
5.9.1 External alarm, reference, monitoring, and control connection locations.....	19
5.9.2 IB2 (controller interface board) connections (if required).....	20
5.9.3 Customer Interface Board Connections – <b>MANDATORY WIRING FOR SYSTEM OPERATON!!</b> .....	24
5.10 NCU Controller Ethernet Connection (if required).....	26
<b>6 Installing Inverter Modules</b> .....	<b>28</b>
<b>7 Initially Starting and Checking System Operation</b> .....	<b>29</b>
7.1 Initial Startup Preparation.....	29
7.2 Initially Starting the System.....	29
7.3 NCU Controller Initialization.....	29
7.4 Checking System Status.....	30

## Admonishments Used in this Document



**DANGER!** Warns of a hazard the reader **will** be exposed to that will **likely** result in death or serious injury if not avoided. (ANSI, OSHA)



**WARNING!** Warns of a potential hazard the reader **may** be exposed to that **could** result in death or serious injury if not avoided. This admonition is not used for situations that pose a risk only to equipment, software, data, or service. (ANSI)



**CAUTION!** Warns of a potential hazard the reader **may** be exposed to that **could** result in minor or moderate injury if not avoided. (ANSI, OSHA) This admonition is not used for situations that pose a risk only to equipment, data, or service, even if such use appears to be permitted in some of the applicable standards. (OSHA)



**ALERT!** Alerts the reader to an action that **must be avoided** in order to protect equipment, software, data, or service. (ISO)



**ALERT!** Alerts the reader to an action that **must be performed** in order to prevent equipment damage, software corruption, data loss, or service interruption. (ISO)



**FIRE SAFETY!** Informs the reader of fire safety information, reminders, precautions, or policies, or of the locations of fire-fighting and fire-safety equipment. (ISO)



**SAFETY!** Informs the reader of general safety information, reminders, precautions, or policies not related to a particular source of hazard or to fire safety. (ISO, ANSI, OSHA)



# **Important Safety Instructions**

## **Safety Admonishments Definitions**

Definitions of the safety admonishments used in this document are listed under “Admonishments Used in this Document” on page iv.

## **Safety and Regulatory Statements**

Refer to Section 4154 (provided with your customer documentation) for Safety and Regulatory Statements.

## **Déclarations de Sécurité et de Réglementation**

Reportez-vous à la Section 4154 (fourni avec les documents de votre client) pour les déclarations de sécurité et de réglementation.

This page intentionally left blank.

# 1 Customer Documentation Package

This document (IM584130100) provides *Installation Instructions* for the Vertiv™ NetSure™ Inverter System: Spec. No. 584130100.

**Table 1.1 Inverter System Configurations**

System Configurations	List Number
19", 5 kVA maximum, Bulk Output Shelf	584130100 List 01
19", 5 kVA maximum, NEMA Output Shelf	584130100 List 07
19", 6 kVA maximum, Bulk Output Shelf	584130100 List 01E
23", 6 kVA maximum (5.76 kVA per NEC breaker de-rating), NEMA Output Shelf	584130100 List 02
23", 6 kVA maximum (5.76 kVA per NEC breaker de-rating), NEMA Output Shelf	584130100 List 02E
19", 10 kVA maximum, Bulk Output Shelf	584130100 List 03
19", 10 kVA maximum, NEMA Output Shelf	584130100 List 08
19", 12 kVA maximum, Bulk Output Shelf	584130100 List 03E
23", 12 kVA maximum (11.5 kVA per NEC breaker de-rating), NEMA Output Shelf	584130100 List 04
23", 12 kVA maximum (11.5 kVA per NEC breaker de-rating), NEMA Output Shelf	584130100 List 04E
19", 15 kVA maximum, Bulk Output Shelf - DC INPUT ONLY	584130100 List 05
19", 20 kVA maximum, Bulk Output Shelf - DC INPUT ONLY	584130100 List 05E
23", 18 kVA maximum (18 kVA per NEC breaker de-rating), NEMA Output Shelf	584130100 List 06
23", 24 kVA maximum (23 kVA per NEC breaker de-rating), NEMA Output Shelf	584130100 List 06E

The complete Customer Documentation Package consists of...

## **System Installation Manual**

- System Installation Instructions: IM584130100

## **Controller User Manual**

- NCU Controller User Instructions: UM1M830BNA

## **USB Drive with All Customer Documentation**

- System Installation Instructions: IM584130100
- System User Instructions: UM584130100
- System "System Application Guide": SAG584130100
- NCU Controller User Instructions: UM1M830BNA
- Inverter Instructions: UM111201000
- Engineering Drawings
  - SD584130100
  - T584130100
- Also provided on the USB drive are the controller configuration files loaded into the controller as shipped and a controller configuration drawing (C-drawing).

For factory settings of all configurable controller parameters, refer to the controller configuration drawing (C-drawing) supplied with your system.

## 2 Installation Acceptance Checklist

Provided in this section is an Installation Acceptance Checklist. This checklist helps ensure proper installation and initial operation of the system. As the procedures presented in this document are completed, check the appropriate box on this list. If the procedure is not required to be performed for your installation site, also check the box in this list to indicate that the procedure was read. When installation is done, ensure that each block in this list has been checked. Some of these procedures may have been factory performed for you.



**NOTE!** The system is not powered up until the end of this checklist.



**NOTE!** Some of these procedures may have been performed at the factory for you.

### **Installing the System**

- Relay Rack Secured to Floor
- System Secured to Relay Rack or Cabinet Equipment Rack (if required)

### **Setting Switches**

- Factory Switch Setting on IB2 Interface Board Verified

### **Making Electrical Connections**

- Relay Rack / Cabinet Frame Grounding Connection Made
- System Shelves Frame Grounding Connections Made
- AC Input and AC Input Equipment Grounding Connections Made (if required)
- DC Input Connections Made
- AC Neutral Reference Point Bonding Busbar Connection Made (if required)
- AC Output Connections Made
- External Alarm, Reference, Monitoring, and Control Connections Made
- NCU Controller Ethernet Connection Made

### **Installing the Inverter Modules**

- Inverter Modules Installed

### **Initially Starting the System**

- System Started and Checked

## 3 Installing the System

### 3.1 General Requirements

- The installer should be familiar with the installation requirements and techniques to be used in securing the relay rack (if furnished) to the floor.
- The installer should be familiar with the installation requirements and techniques to be used in securing the system to a relay rack or equipment rack.
- This product is recommended to be installed in a restricted access location on or above a non-combustible surface.
- This product is recommended to be located in a controlled environment with access to Crafts persons only.
- The system must be mounted in an environment that does not exceed the rated operating ambient temperature range found in SAG584130100.
- Clearance requirements are (relay rack or equipment rack):
  - Recommended minimum aisle space clearance for the front of each bay is 2'6" (for operation and maintenance).
  - Recommended minimum aisle space clearance for the rear of each bay is 2'0" (for installation and maintenance).
  - No space required above or below the unit (for ventilation only, installation and maintenance may require more clearance).

### 3.2 Securing the System to a Relay Rack or a Cabinet Equipment Rack



**DANGER!** If the system is going to be mounted in a relay rack, the relay rack must be securely anchored to the floor before the system is installed.



**NOTE!** Refer to "General Requirements" on page 3 for general requirements.



**NOTE!** The shelves comprising this system are factory connected together. The shelves are mounted as a complete system.

This system is designed to mount in a standard 19" or 23" wide relay rack or equipment rack (depending on configuration) having 1-3/4" multiple drillings. Refer to System Application Guide SAG584130100 for overall dimensions and a list of available relay racks.

#### **Procedure**

1. Position the system in the relay rack or cabinet equipment rack.
2. Secure the system to the relay rack or cabinet equipment rack using hardware as shown in Figure 3.3 (see Figure 3.3 for recommended torque). Use grounding washers as indicated in Figure 3.3.



**NOTE!** Install (orient) the ground washers so the teeth dig into the mounting angles for a secure ground connection.

Figure 3.1 Mounting the System in a Relay Rack or a Cabinet Equipment Rack

584130100 List 05 Shown.  
Other Configurations Similar.

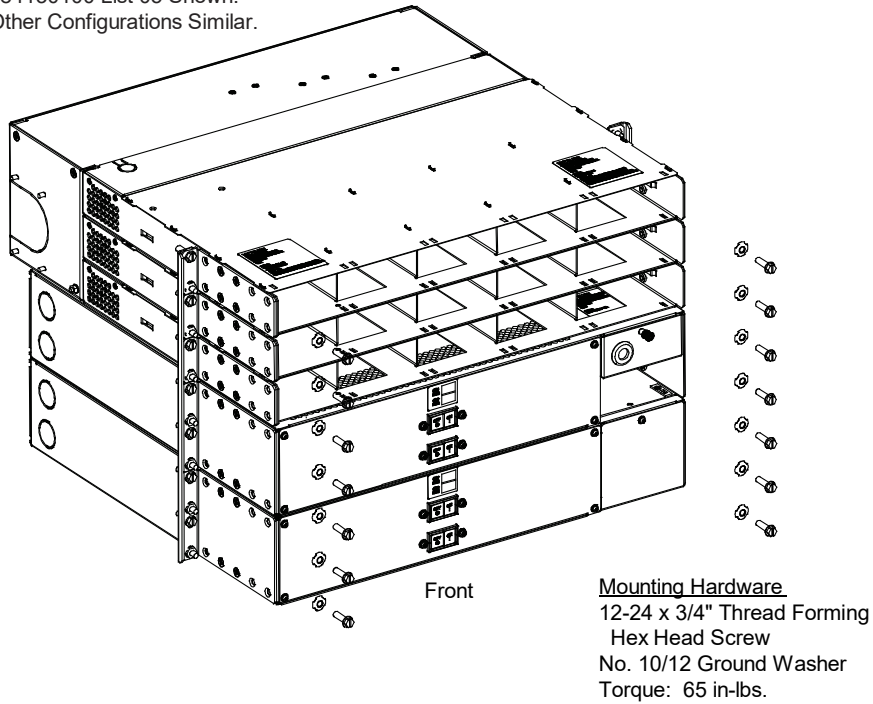

## 4 Setting Switches

### 4.1 Switch Setting on IB2 Controller Interface Board

Dip Switch SW1 on the IB2 board is used to set the communications address for this board. Refer to Table 4.1 for SW1 settings. Refer to Figure 4.1 for circuit card and switch location.

Perform the following procedure to verify the factory setting. This procedure can also be used to make adjustment on a replacement circuit card.

**Procedure**

1. Ensure SW1 is set per Table 4.1. Refer to Figure 4.1 for circuit card and switch location.

Table 4.1 IB2 Controller Interface Board Switch Setting

Setting	DIP Switch SW1	
	1	2
IB2-1	OFF	OFF

Figure 4.1 IB2 Controller Interface Board Switch Location and Setting

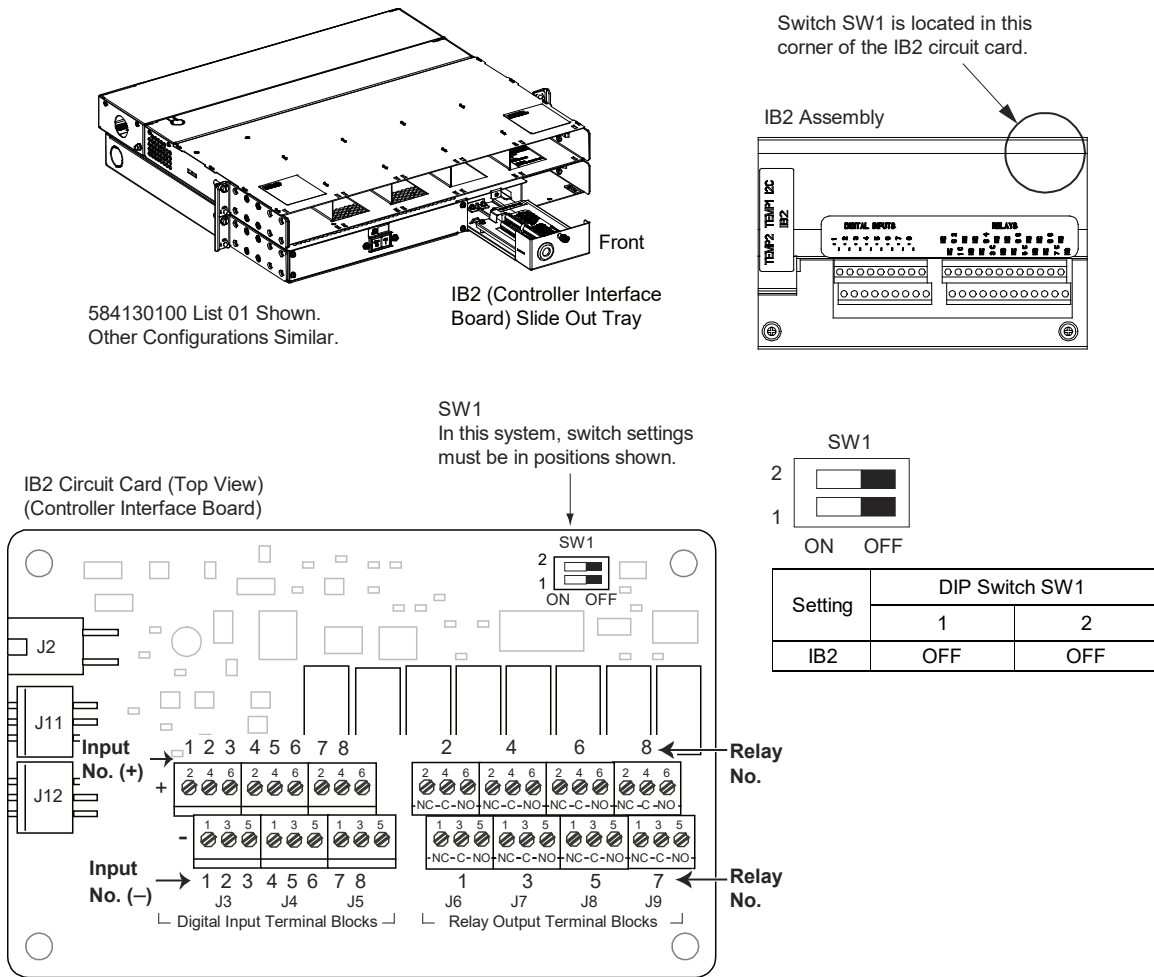

## 5 Making Electrical Connections

### 5.1 Important Safety Instructions



**DANGER!** Adhere to the “Important Safety Instructions” starting on page v.

### 5.2 Wiring Considerations

All wiring and branch circuit protection should follow the current edition of the American National Standards Institute (ANSI) approved National Fire Protection Association’s (NFPA) National Electrical Code (NEC), and applicable local codes. For operation in countries where the NEC is not recognized, follow applicable codes.

For wire size, branch circuit protection, crimp lug, and general wiring recommendations; refer to System Application Guide SAG584130100. Lugs must be crimped per lug manufacturer’s specifications.

### 5.3 Relay Rack / Cabinet Frame Grounding Connection

For relay rack / cabinet frame grounding requirements, refer to the current edition of the American National Standards Institute (ANSI) approved National Fire Protection Association's (NFPA) National Electrical Code (NEC), applicable local codes, and your specific site requirements.

**Procedure**

1. Attach a customer grounding network lead to the equipment mounting rack per site requirements. Holes are provided on the top of each relay rack for installing a lead with a two-hole lug that has 1/4" bolt clearance holes on 5/8" centers. When using 1/4-inch hardware, recommended torque is 84 in-lbs when a standard flat washer and lock washer are used. Refer to Figure 5.1 for locations.



**NOTE!** REMOVE TAPE FROM HOLE LOCATIONS BEFORE INSTALLING LUG.

**Figure 5.1 Relay Rack Frame Grounding Connection Points**

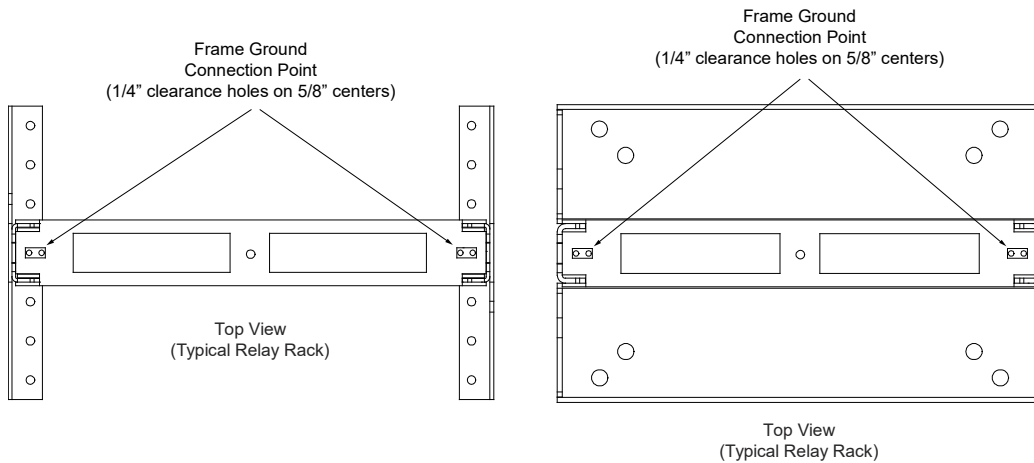



## 5.4 System Shelves Frame Grounding Connections

For system shelf grounding requirements, refer to the current edition of the American National Standards Institute (ANSI) approved National Fire Protection Association's (NFPA) National Electrical Code (NEC), applicable local codes, and your specific site requirements.

A connection to the customer's grounding network or main grounding electrode is made using a grounding electrode conductor terminated on the system enclosure. System shelf grounding is accomplished through ground washers properly installed on the relay rack mounting brackets.

### Procedure

1. The frame grounding connection to the system shelves are made by using grounding washers with the mounting hardware used to secure the shelves to the relay rack or cabinet. Refer to "Securing the System to a Relay Rack or a Cabinet Equipment Rack (if required)" on page 3. Ensure that the relay rack or cabinet is properly grounded.
2. A direct connection to the main grounding electrode is required even if the relay rack or cabinet frame is already grounded. A 1/4-20 frame ground point (marked "Grounding Electrode Terminal") is located on the rear of the system near the AC input (see Figure 5.2 for typical location of the Grounding Electrode Terminal). Terminal hardware is shipped loose with the system and must be installed after the system is mounted to the relay rack or cabinet frame. Provide a grounding electrode conductor to this point using a copper conductor that complies with National Electrical Code (NEC) for ampacity. Refer to SAG584130100 for ground lead size recommendation and lug selection. Torque hardware as indicated in Figure 5.2.

**Figure 5.2 Typical Location of Grounding Electrode Terminal**

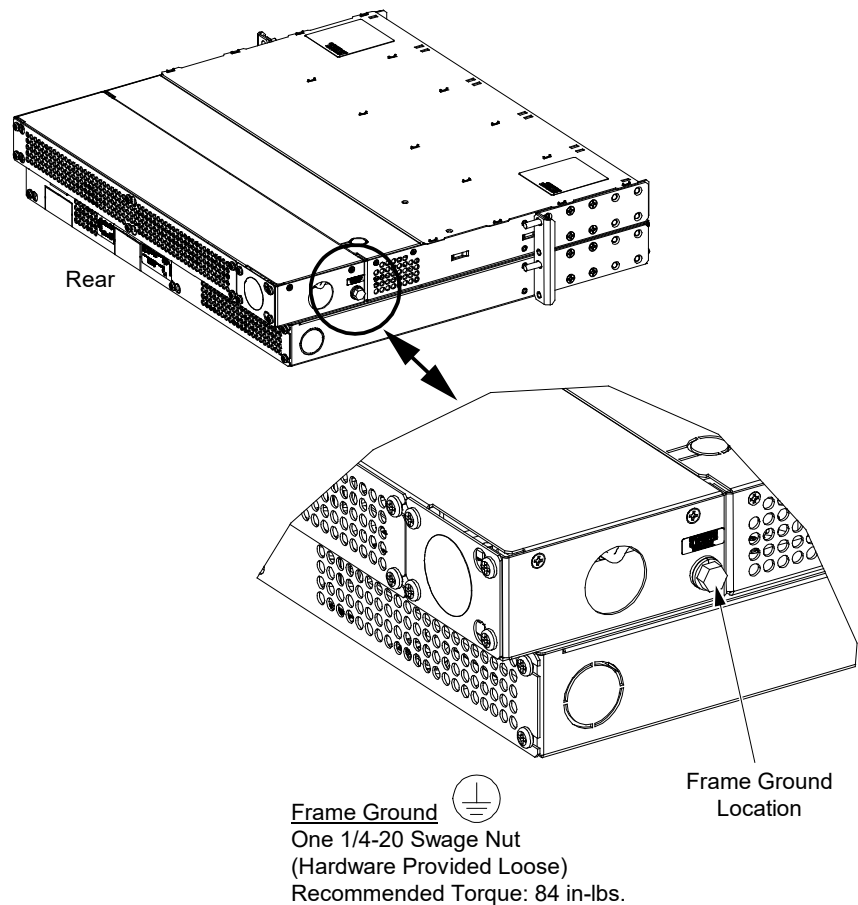

## 5.5 Nominal 120 VAC Input and Equipment Grounding Connections (Spec. No. 584130100 Lists 01, 01E, 02, 02E, 03, 03E, 04, 04E, 06, 06E, 07, and 08 - does NOT apply to Lists 05 and 05E)

The AC input connections are made to an AC input terminal block located in the right-rear of the inverter module mounting shelf portion of the system.

### **Procedure**

Refer to Figure 5.3 as this procedure is performed.



**NOTE!** A grounding conductor must be provided with each conduit. Make equipment grounding connections to earth ground, not to the branch circuit neutral conductor.

1. Remove the access cover from the rear of the inverter module mounting shelf portion of the system.
2. For all Lists except 01, 02 and 07, remove the conduit plate from the right side (as viewed from the rear) of the inverter module mounting shelf portion of the system.
3. For Lists 01, 02, and 07, if using the rear panel location, transfer the plug button factory installed in this location to the conduit hole in the right-side panel.
4. Install an appropriate size conduit fitting (see SAG584130100 for details) as required.
5. Route commercial AC input and ground leads into the inverter module mounting shelf portion of the system through the previously installed conduit fitting.
6. Connect the commercial AC input leads to the AC input terminal block inside the inverter module mounting shelf portion of the system as shown in Figure 5.3. Connect each wire by inserting the stripped end into the wire opening, and then tightening the screw. Torque connections to value shown in Figure 5.3.
7. Connect equipment grounding leads to the frame ground stud using installer-provided lug and factory-supplied mounting hardware. Torque connection to value shown in Figure 5.3.
8. After all AC input and equipment grounding connections have been made and checked, reinstall the rear access cover.

### **IMPORTANT NOTE:**

**Please see mandatory Customer Interface Board wiring outlined on page 24. The NCU and system will NOT operate without these connections!!**

Figure 5.3 Nominal 120 VAC Input and Equipment Grounding Connections

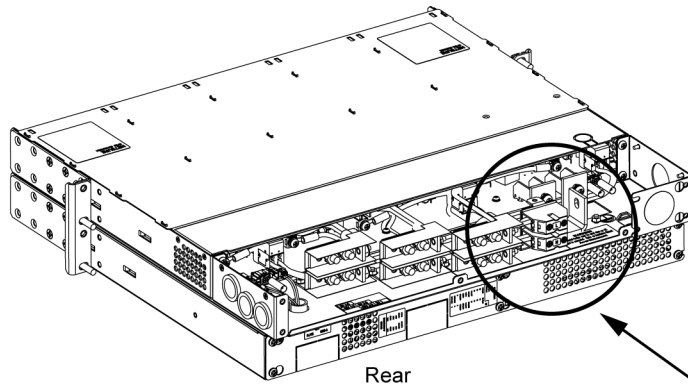

584130100 List 01 Shown.  
Other Configurations Similar.

Rear Panel(s) Removed in Illustrations

584130100 List 01 Wire Size Capacity: 20 AWG to 4 AWG.  
584130100 List 02 Recommended Torque: 26 in-lbs.  
584130100 List 07

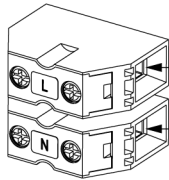

Line  
Neutral  
AC Input Feed Terminal Block  
120 VAC, 50 / 60 HZ,  
Single Phase

584130100 List 01E Wire Size Capacity: 14 AWG to 2/0 AWG.  
584130100 List 02E Recommended Torque:  
584130100 List 03 35 lbf.in (3.95 N.m) 12 AWG  
584130100 List 03E 35 lbf.in (3.95 N.m) 14 AWG  
584130100 List 04 40 lbf.in (4.52 N.m) 8 AWG  
584130100 List 08 120 lbf.in (13.56 N.m) 6 AWG to 2/0 AWG

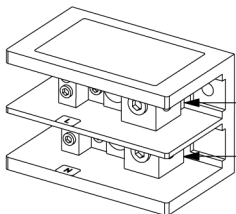

Line  
Neutral  
AC Input Feed Terminal Block  
120 VAC, 50 / 60 HZ,  
Single Phase

584130100 List 04E Wire Size Capacity: 14 AWG to 2/0 AWG.  
584130100 List 06 Recommended Torque:  
584130100 List 06E 35 lbf.in (3.95 N.m) 14 AWG to 10 AWG  
40 lbf.in (4.52 N.m) 8 AWG  
120 lbf.in (13.56 N.m) 6 AWG to 2/0 AWG

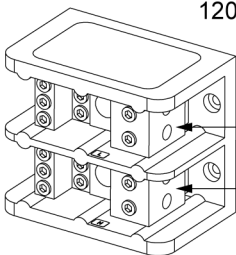

Line  
Neutral  
AC Input Feed Terminal Block  
120 VAC, 50 / 60 HZ,  
Single Phase

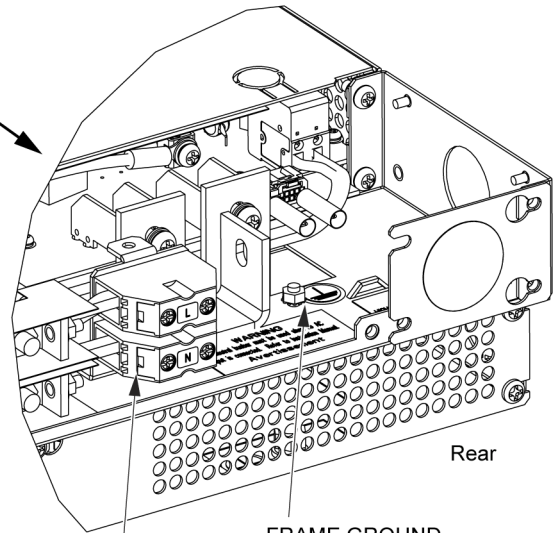

AC Input Feed Terminal Block  
120 VAC, 50 / 60 HZ,  
Single Phase

**FRAME GROUND**  
One M4 x 7mm Stud and Hardware.  
Recommended torque: 20 in-lbs.

## 5.6 Nominal -48 VDC Input Connections

The DC input connections are made to the rear of the inverter module mounting shelf(s) comprising the system.



**NOTE!** *If the input to the inverter system is provided from a DC input source only (no AC input), an AC neutral reference must be provided by bonding the "Neutral" output of the inverter shelf to the frame of the inverter shelf with the furnished bonding busbar. See "AC Neutral Reference Point (When DC Input Source Only Connected)" on page 14.*

### **Procedure**

Refer to Figure 5.4 as this procedure is performed.

1. Remove the access cover from the rear of the inverter module mounting shelf portion of the system.
2. Install 1/2-inch or 1-inch conduit fittings (depends on configuration) as required in the left-side panel (as viewed from the rear).
3. Route DC input leads into the inverter module mounting shelf(s) through the previously installed conduit fitting(s).
4. Connect the DC input leads to the appropriate DC input terminals inside the inverter module mounting shelf(s) as shown in Figure 5.4. Torque connections to value shown in Figure 5.4.
5. After all DC input connections have been made and checked, reinstall the rear access cover.

Figure 5.4 Nominal -48 VDC Input Connections (cont'd on next page)

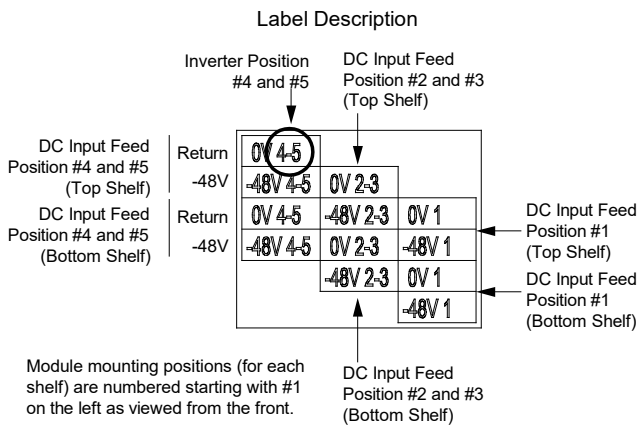

584130100 List 03 Shown.  
Other Configurations Similar.

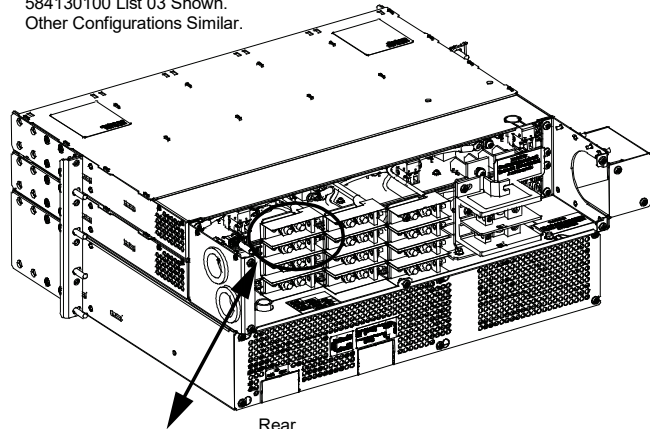

1/4-20 Studs and Hardware.  
Recommended torque: 58 in-lbs.

Rear

Rear Panel(s) Removed in Illustrations

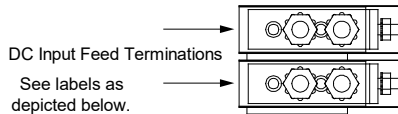

584130100 List 01 and 07	584130100 List 02	584130100 List 01E	584130100 List 02E																																																																																																
<table border="1"> <tr><td>0V 4-5</td><td></td><td></td></tr> <tr><td>-48V 4-5</td><td>0V 2-3</td><td></td></tr> <tr><td></td><td>-48V 2-3</td><td>0V 1</td></tr> <tr><td></td><td></td><td>-48V 1</td></tr> </table>	0V 4-5			-48V 4-5	0V 2-3			-48V 2-3	0V 1			-48V 1	<table border="1"> <tr><td>0V 5-6</td><td></td><td></td></tr> <tr><td>-48V 5-6</td><td>0V 3-4</td><td></td></tr> <tr><td></td><td>-48V 3-4</td><td>0V 1-2</td></tr> <tr><td></td><td></td><td>-48V 1-2</td></tr> </table>	0V 5-6			-48V 5-6	0V 3-4			-48V 3-4	0V 1-2			-48V 1-2	<table border="1"> <tr><td>0V 4-5</td><td></td><td></td></tr> <tr><td>-48V 4-5</td><td>0V 2-3</td><td></td></tr> <tr><td>0V 4-5</td><td>-48V 2-3</td><td>0V 1</td></tr> <tr><td>-48V 4-5</td><td>0V 2-3</td><td>-48V 1</td></tr> <tr><td></td><td>-48V 2-3</td><td>0V 1</td></tr> <tr><td></td><td></td><td>-48V 1</td></tr> </table>	0V 4-5			-48V 4-5	0V 2-3		0V 4-5	-48V 2-3	0V 1	-48V 4-5	0V 2-3	-48V 1		-48V 2-3	0V 1			-48V 1	<table border="1"> <tr><td>0V 5-6</td><td></td><td></td></tr> <tr><td>-48V 5-6</td><td>0V 3-4</td><td></td></tr> <tr><td>0V 5-6</td><td>-48V 3-4</td><td>0V 1-2</td></tr> <tr><td>-48V 5-6</td><td>0V 3-4</td><td>-48V 1-2</td></tr> <tr><td></td><td>-48V 3-4</td><td>0V 1-2</td></tr> <tr><td></td><td></td><td>-48V 1-2</td></tr> </table>	0V 5-6			-48V 5-6	0V 3-4		0V 5-6	-48V 3-4	0V 1-2	-48V 5-6	0V 3-4	-48V 1-2		-48V 3-4	0V 1-2			-48V 1-2																																				
0V 4-5																																																																																																			
-48V 4-5	0V 2-3																																																																																																		
	-48V 2-3	0V 1																																																																																																	
		-48V 1																																																																																																	
0V 5-6																																																																																																			
-48V 5-6	0V 3-4																																																																																																		
	-48V 3-4	0V 1-2																																																																																																	
		-48V 1-2																																																																																																	
0V 4-5																																																																																																			
-48V 4-5	0V 2-3																																																																																																		
0V 4-5	-48V 2-3	0V 1																																																																																																	
-48V 4-5	0V 2-3	-48V 1																																																																																																	
	-48V 2-3	0V 1																																																																																																	
		-48V 1																																																																																																	
0V 5-6																																																																																																			
-48V 5-6	0V 3-4																																																																																																		
0V 5-6	-48V 3-4	0V 1-2																																																																																																	
-48V 5-6	0V 3-4	-48V 1-2																																																																																																	
	-48V 3-4	0V 1-2																																																																																																	
		-48V 1-2																																																																																																	
584130100 List 03 and 08	584130100 List 04	584130100 List 03E	584130100 List 04E																																																																																																
<table border="1"> <tr><td>0V 4-5</td><td></td><td></td></tr> <tr><td>-48V 4-5</td><td>0V 2-3</td><td></td></tr> <tr><td>0V 4-5</td><td>-48V 2-3</td><td>0V 1</td></tr> <tr><td>-48V 4-5</td><td>0V 2-3</td><td>-48V 1</td></tr> <tr><td></td><td>-48V 2-3</td><td>0V 1</td></tr> <tr><td></td><td></td><td>-48V 1</td></tr> </table>	0V 4-5			-48V 4-5	0V 2-3		0V 4-5	-48V 2-3	0V 1	-48V 4-5	0V 2-3	-48V 1		-48V 2-3	0V 1			-48V 1	<table border="1"> <tr><td>0V 5-6</td><td></td><td></td></tr> <tr><td>-48V 5-6</td><td>0V 3-4</td><td></td></tr> <tr><td>0V 5-6</td><td>-48V 3-4</td><td>0V 1-2</td></tr> <tr><td>-48V 5-6</td><td>0V 3-4</td><td>-48V 1-2</td></tr> <tr><td></td><td>-48V 3-4</td><td>0V 1-2</td></tr> <tr><td></td><td></td><td>-48V 1-2</td></tr> </table>	0V 5-6			-48V 5-6	0V 3-4		0V 5-6	-48V 3-4	0V 1-2	-48V 5-6	0V 3-4	-48V 1-2		-48V 3-4	0V 1-2			-48V 1-2	<table border="1"> <tr><td>0V 4-5</td><td></td><td></td></tr> <tr><td>-48V 4-5</td><td>0V 2-3</td><td></td></tr> <tr><td>0V 4-5</td><td>-48V 2-3</td><td>0V 1</td></tr> <tr><td>-48V 4-5</td><td>0V 2-3</td><td>-48V 1</td></tr> <tr><td>0V 4-5</td><td>-48V 2-3</td><td>0V 1</td></tr> <tr><td>-48V 4-5</td><td>0V 2-3</td><td>-48V 1</td></tr> <tr><td></td><td>-48V 2-3</td><td>0V 1</td></tr> <tr><td></td><td></td><td>-48V 1</td></tr> </table>	0V 4-5			-48V 4-5	0V 2-3		0V 4-5	-48V 2-3	0V 1	-48V 4-5	0V 2-3	-48V 1	0V 4-5	-48V 2-3	0V 1	-48V 4-5	0V 2-3	-48V 1		-48V 2-3	0V 1			-48V 1	<table border="1"> <tr><td>0V 5-6</td><td></td><td></td></tr> <tr><td>-48V 5-6</td><td>0V 3-4</td><td></td></tr> <tr><td>0V 5-6</td><td>-48V 3-4</td><td>0V 1-2</td></tr> <tr><td>-48V 5-6</td><td>0V 3-4</td><td>-48V 1-2</td></tr> <tr><td>0V 5-6</td><td>-48V 3-4</td><td>0V 1-2</td></tr> <tr><td>-48V 5-6</td><td>0V 3-4</td><td>-48V 1-2</td></tr> <tr><td></td><td>-48V 3-4</td><td>0V 1-2</td></tr> <tr><td></td><td></td><td>-48V 1-2</td></tr> </table>	0V 5-6			-48V 5-6	0V 3-4		0V 5-6	-48V 3-4	0V 1-2	-48V 5-6	0V 3-4	-48V 1-2	0V 5-6	-48V 3-4	0V 1-2	-48V 5-6	0V 3-4	-48V 1-2		-48V 3-4	0V 1-2			-48V 1-2												
0V 4-5																																																																																																			
-48V 4-5	0V 2-3																																																																																																		
0V 4-5	-48V 2-3	0V 1																																																																																																	
-48V 4-5	0V 2-3	-48V 1																																																																																																	
	-48V 2-3	0V 1																																																																																																	
		-48V 1																																																																																																	
0V 5-6																																																																																																			
-48V 5-6	0V 3-4																																																																																																		
0V 5-6	-48V 3-4	0V 1-2																																																																																																	
-48V 5-6	0V 3-4	-48V 1-2																																																																																																	
	-48V 3-4	0V 1-2																																																																																																	
		-48V 1-2																																																																																																	
0V 4-5																																																																																																			
-48V 4-5	0V 2-3																																																																																																		
0V 4-5	-48V 2-3	0V 1																																																																																																	
-48V 4-5	0V 2-3	-48V 1																																																																																																	
0V 4-5	-48V 2-3	0V 1																																																																																																	
-48V 4-5	0V 2-3	-48V 1																																																																																																	
	-48V 2-3	0V 1																																																																																																	
		-48V 1																																																																																																	
0V 5-6																																																																																																			
-48V 5-6	0V 3-4																																																																																																		
0V 5-6	-48V 3-4	0V 1-2																																																																																																	
-48V 5-6	0V 3-4	-48V 1-2																																																																																																	
0V 5-6	-48V 3-4	0V 1-2																																																																																																	
-48V 5-6	0V 3-4	-48V 1-2																																																																																																	
	-48V 3-4	0V 1-2																																																																																																	
		-48V 1-2																																																																																																	
584130100 List 05	584130100 List 06	584130100 List 05E	584130100 List 06E																																																																																																
<table border="1"> <tr><td>0V 4-5</td><td></td><td></td></tr> <tr><td>-48V 4-5</td><td>0V 2-3</td><td></td></tr> <tr><td>0V 4-5</td><td>-48V 2-3</td><td>0V 1</td></tr> <tr><td>-48V 4-5</td><td>0V 2-3</td><td>-48V 1</td></tr> <tr><td>0V 4-5</td><td>-48V 2-3</td><td>0V 1</td></tr> <tr><td>-48V 4-5</td><td>0V 2-3</td><td>-48V 1</td></tr> <tr><td></td><td>-48V 2-3</td><td>0V 1</td></tr> <tr><td></td><td></td><td>-48V 1</td></tr> </table>	0V 4-5			-48V 4-5	0V 2-3		0V 4-5	-48V 2-3	0V 1	-48V 4-5	0V 2-3	-48V 1	0V 4-5	-48V 2-3	0V 1	-48V 4-5	0V 2-3	-48V 1		-48V 2-3	0V 1			-48V 1	<table border="1"> <tr><td>0V 5-6</td><td></td><td></td></tr> <tr><td>-48V 5-6</td><td>0V 3-4</td><td></td></tr> <tr><td>0V 5-6</td><td>-48V 3-4</td><td>0V 1-2</td></tr> <tr><td>-48V 5-6</td><td>0V 3-4</td><td>-48V 1-2</td></tr> <tr><td>0V 5-6</td><td>-48V 3-4</td><td>0V 1-2</td></tr> <tr><td>-48V 5-6</td><td>0V 3-4</td><td>-48V 1-2</td></tr> <tr><td></td><td>-48V 3-4</td><td>0V 1-2</td></tr> <tr><td></td><td></td><td>-48V 1-2</td></tr> </table>	0V 5-6			-48V 5-6	0V 3-4		0V 5-6	-48V 3-4	0V 1-2	-48V 5-6	0V 3-4	-48V 1-2	0V 5-6	-48V 3-4	0V 1-2	-48V 5-6	0V 3-4	-48V 1-2		-48V 3-4	0V 1-2			-48V 1-2	<table border="1"> <tr><td>0V 4-5</td><td></td><td></td></tr> <tr><td>-48V 4-5</td><td>0V 2-3</td><td></td></tr> <tr><td>0V 4-5</td><td>-48V 2-3</td><td>0V 1</td></tr> <tr><td>-48V 4-5</td><td>0V 2-3</td><td>-48V 1</td></tr> <tr><td>0V 4-5</td><td>-48V 2-3</td><td>0V 1</td></tr> <tr><td>-48V 4-5</td><td>0V 2-3</td><td>-48V 1</td></tr> <tr><td></td><td>-48V 2-3</td><td>0V 1</td></tr> <tr><td></td><td></td><td>-48V 1</td></tr> </table>	0V 4-5			-48V 4-5	0V 2-3		0V 4-5	-48V 2-3	0V 1	-48V 4-5	0V 2-3	-48V 1	0V 4-5	-48V 2-3	0V 1	-48V 4-5	0V 2-3	-48V 1		-48V 2-3	0V 1			-48V 1	<table border="1"> <tr><td>0V 5-6</td><td></td><td></td></tr> <tr><td>-48V 5-6</td><td>0V 3-4</td><td></td></tr> <tr><td>0V 5-6</td><td>-48V 3-4</td><td>0V 1-2</td></tr> <tr><td>-48V 5-6</td><td>0V 3-4</td><td>-48V 1-2</td></tr> <tr><td>0V 5-6</td><td>-48V 3-4</td><td>0V 1-2</td></tr> <tr><td>-48V 5-6</td><td>0V 3-4</td><td>-48V 1-2</td></tr> <tr><td></td><td>-48V 3-4</td><td>0V 1-2</td></tr> <tr><td></td><td></td><td>-48V 1-2</td></tr> </table>	0V 5-6			-48V 5-6	0V 3-4		0V 5-6	-48V 3-4	0V 1-2	-48V 5-6	0V 3-4	-48V 1-2	0V 5-6	-48V 3-4	0V 1-2	-48V 5-6	0V 3-4	-48V 1-2		-48V 3-4	0V 1-2			-48V 1-2
0V 4-5																																																																																																			
-48V 4-5	0V 2-3																																																																																																		
0V 4-5	-48V 2-3	0V 1																																																																																																	
-48V 4-5	0V 2-3	-48V 1																																																																																																	
0V 4-5	-48V 2-3	0V 1																																																																																																	
-48V 4-5	0V 2-3	-48V 1																																																																																																	
	-48V 2-3	0V 1																																																																																																	
		-48V 1																																																																																																	
0V 5-6																																																																																																			
-48V 5-6	0V 3-4																																																																																																		
0V 5-6	-48V 3-4	0V 1-2																																																																																																	
-48V 5-6	0V 3-4	-48V 1-2																																																																																																	
0V 5-6	-48V 3-4	0V 1-2																																																																																																	
-48V 5-6	0V 3-4	-48V 1-2																																																																																																	
	-48V 3-4	0V 1-2																																																																																																	
		-48V 1-2																																																																																																	
0V 4-5																																																																																																			
-48V 4-5	0V 2-3																																																																																																		
0V 4-5	-48V 2-3	0V 1																																																																																																	
-48V 4-5	0V 2-3	-48V 1																																																																																																	
0V 4-5	-48V 2-3	0V 1																																																																																																	
-48V 4-5	0V 2-3	-48V 1																																																																																																	
	-48V 2-3	0V 1																																																																																																	
		-48V 1																																																																																																	
0V 5-6																																																																																																			
-48V 5-6	0V 3-4																																																																																																		
0V 5-6	-48V 3-4	0V 1-2																																																																																																	
-48V 5-6	0V 3-4	-48V 1-2																																																																																																	
0V 5-6	-48V 3-4	0V 1-2																																																																																																	
-48V 5-6	0V 3-4	-48V 1-2																																																																																																	
	-48V 3-4	0V 1-2																																																																																																	
		-48V 1-2																																																																																																	

Figure 5.4 Nominal -48 VDC Input Connections (cont'd from previous page, cont'd on next page)

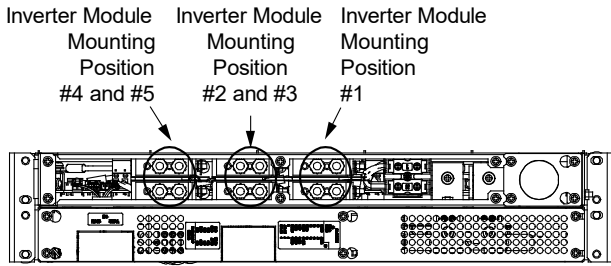

Rear 584130100 List 01 and 07

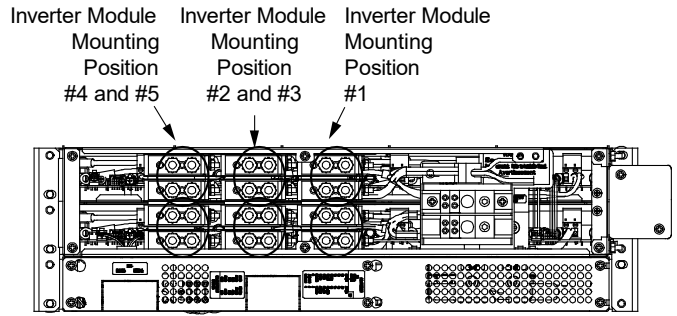

Rear 584130100 List 01E

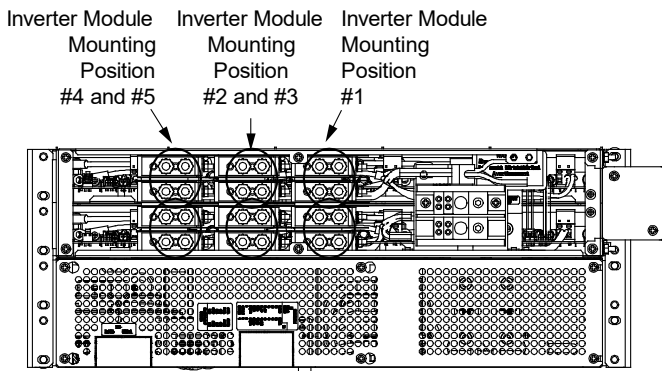

Rear 584130100 List 03 and 08

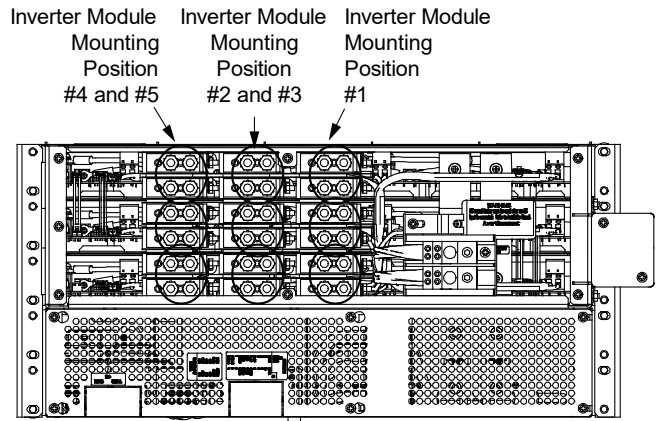

Rear 584130100 List 03E

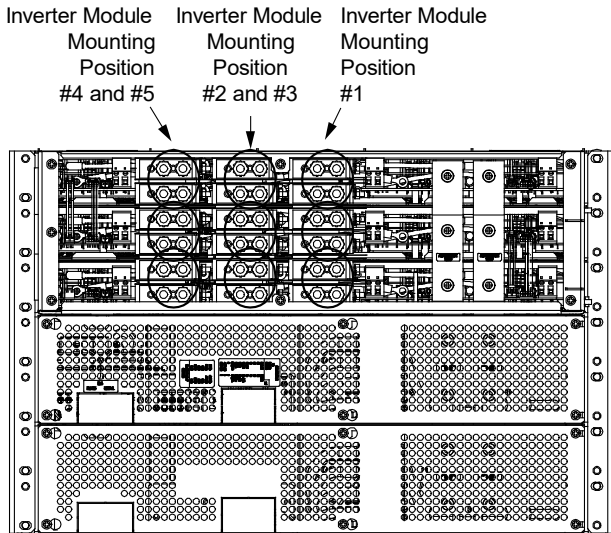

Rear 584130100 List 05

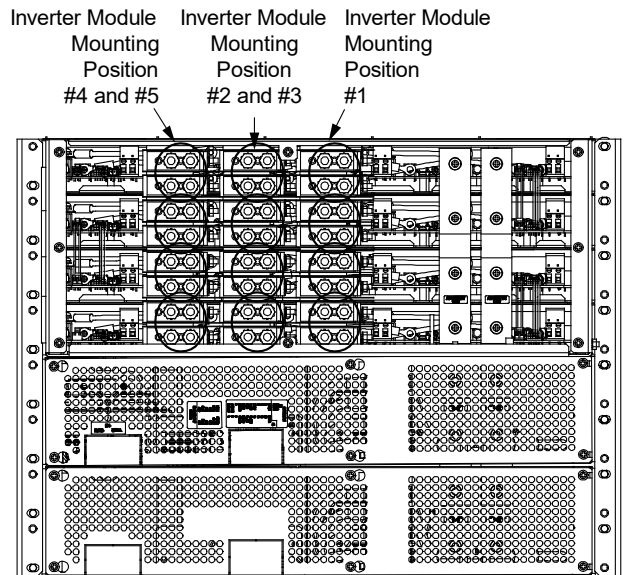

Rear 584130100 List 05E



Figure 5.4 Nominal -48 VDC Input Connections (cont'd from previous page)

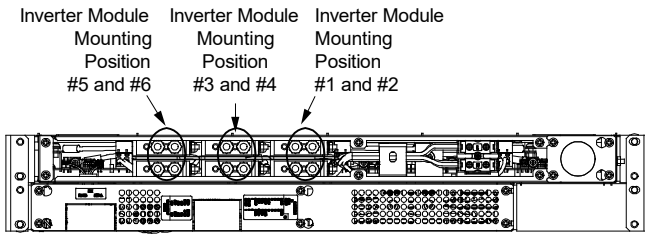

Rear 584130100 List 02

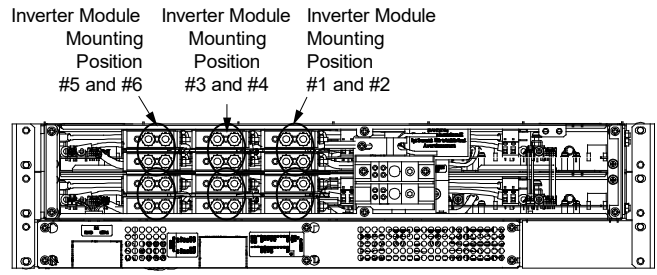

Rear 584130100 List 02E

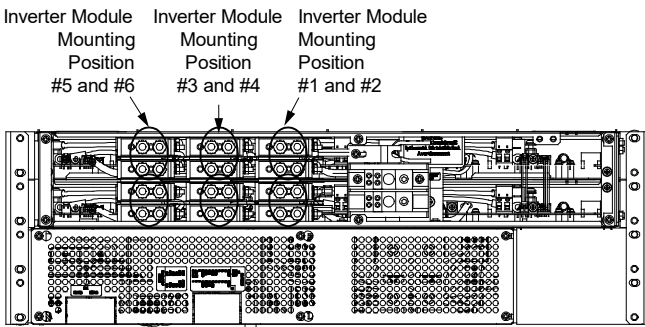

Rear 584130100 List 04

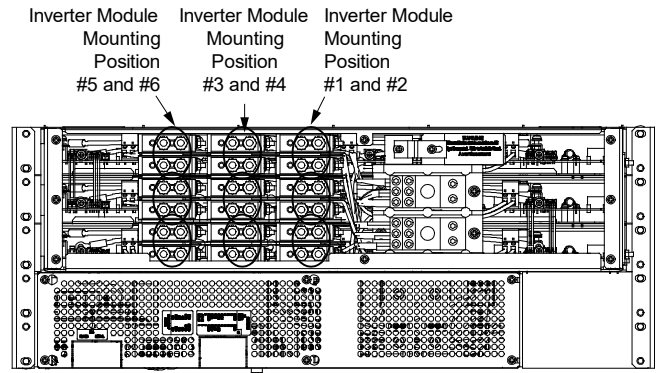

Rear 584130100 List 04E

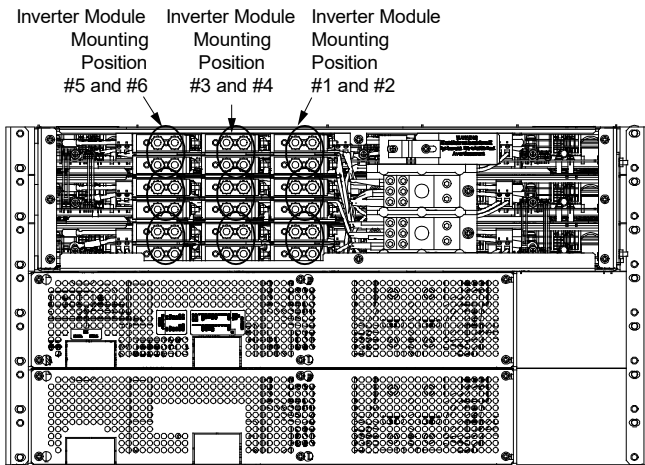

Rear 584130100 List 06

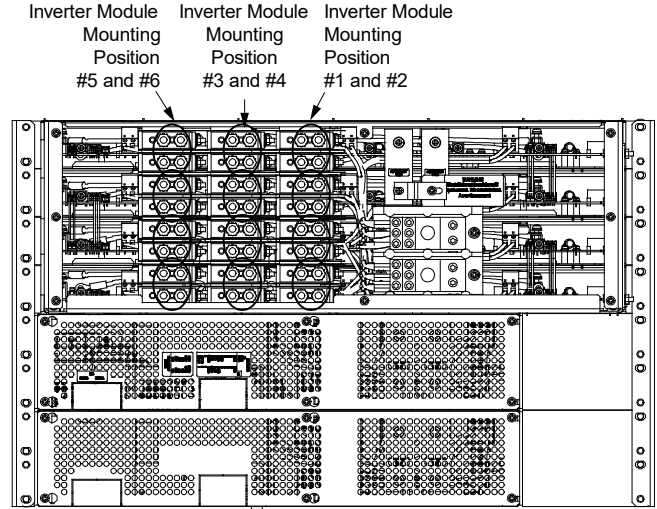

Rear 584130100 List 06E

## 5.7 AC Neutral Reference Point (When DC Input Source Only Connected)



**NOTE!** This procedure is factory performed for Lists 05 and 05E. These are DC input source only configurations. Perform this procedure for all other List Numbers as required or to check the setting in a List 05 and 05E.

If the input to the inverter system is provided from a DC input source only (no AC input), an AC neutral reference must be provided by bonding the "Neutral" output of the inverter shelf to the frame of the inverter shelf with the furnished bonding busbar. Refer to the following procedure.

### **Procedure**

Refer to Figure 5.5 as this procedure is performed.

1. Remove the access cover from the rear of the inverter module mounting shelf portion of the system.
2. Locate the bonding busbar stored near the AC output neutral busbar. See Figure 5.5.
3. Remove the hardware securing the bonding busbar. Rotate or flip the bonding busbar over as required so it bonds the AC Output "Neutral" busbar to the frame of the inverter shelf. See Figure 5.5. Note that the hardware from the AC Output "Neutral" busbar needs to be removed first in the position where the bonding busbar will be secured. Secure the bonding busbar with the hardware previously removed. Torque the connections as indicated in Figure 5.5.
4. Reinstall the rear access cover.



Figure 5.5 AC "Neutral" Reference Point

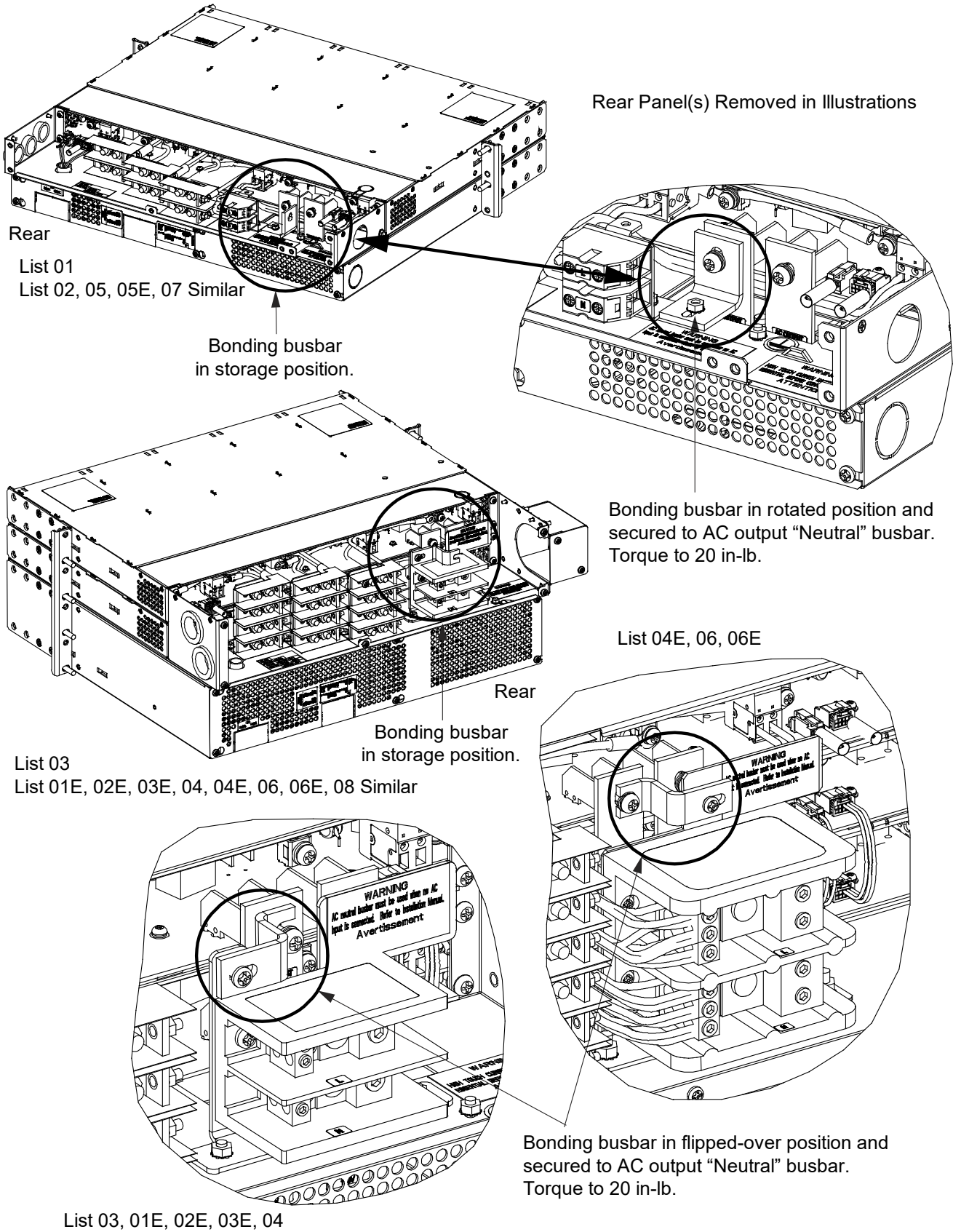

## 5.8 Nominal 120 VAC Output Connections

The AC output connections are made to the AC distribution shelf(s) comprising the system.

### 5.8.1 List 01, 01E, 03, 03E, 05, and 05E (bulk output)

#### **Procedure**

Refer to Figure 5.6 as this procedure is performed.



**NOTE!** A grounding conductor must be provided with each conduit.

1. Remove the access cover from the rear of the AC distribution shelf(s).
2. Install a 3/4-inch conduit fitting(s) as required in the right-side panel (as viewed from the rear) of the AC distribution shelf(s).
3. Route AC output and ground leads into the AC distribution shelf(s) through the previously installed conduit fitting(s).
4. Connect the AC output leads to the appropriate AC output terminal block inside the AC distribution shelf(s) as shown in Figure 5.6. Connect each wire by inserting the stripped end into the wire opening, and then tightening the screw. Torque connections to value shown in Figure 5.6.
5. Connect ground leads to the frame ground stud(s) using installer-provided lug(s) and factory-supplied mounting hardware. Torque connections to value shown in Figure 5.6.
6. After all AC output and ground connections have been made and checked, reinstall the rear access cover(s).

### 5.8.2 List 02, 02E, 04, 04E, 06, 06E, 07, and 08 (NEMA output)

#### **Procedure**

Refer to Figure 5.7 as this procedure is performed.

1. Connect the AC output leads to the NEMA 5-15R receptacles provided on the front of the system. See Figure 5.7.

Figure 5.6 Nominal 120 VAC Output Connections, Lists 01, 01E, 03, 03E, 05, and 05E (Bulk Output)

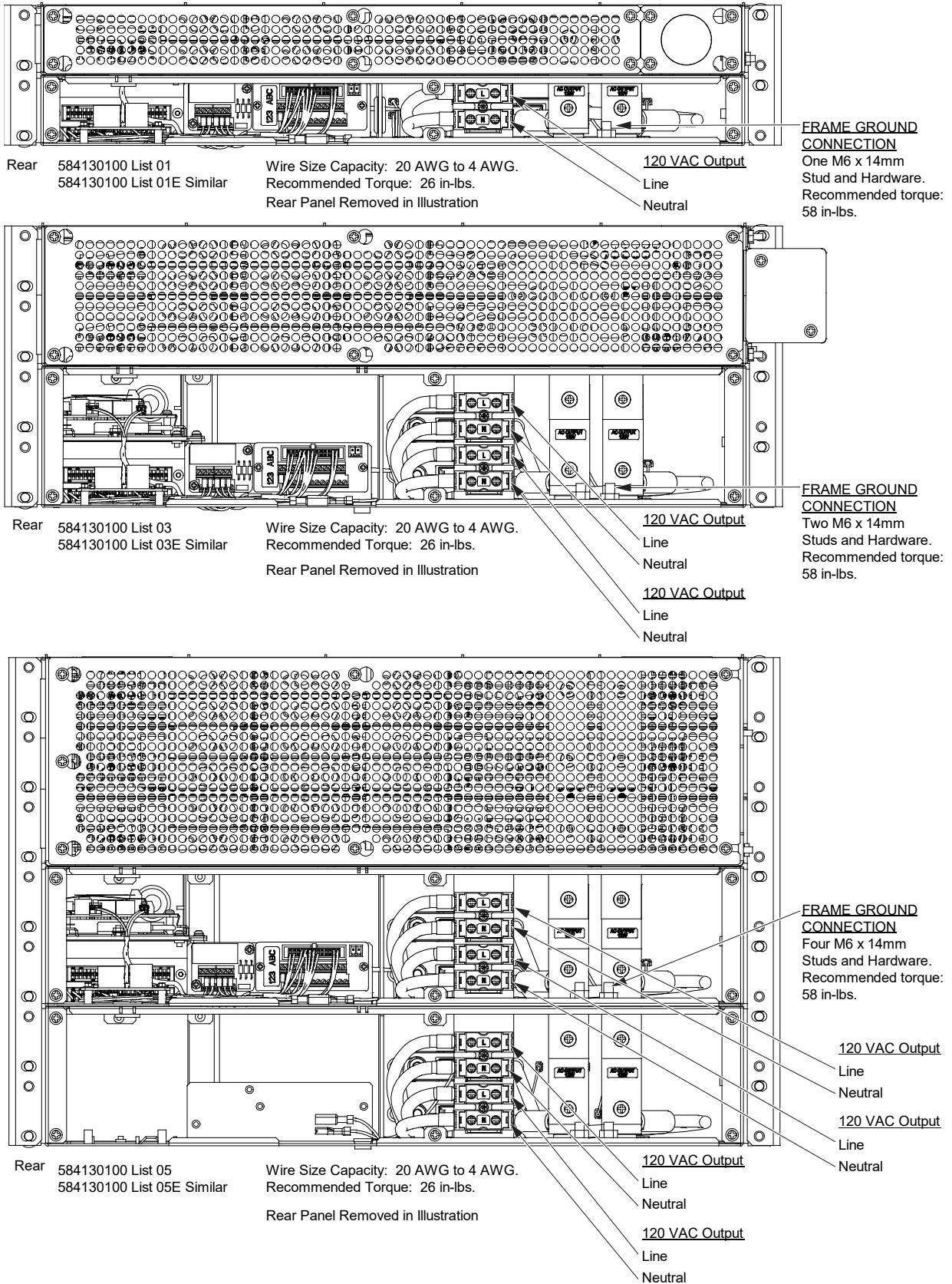
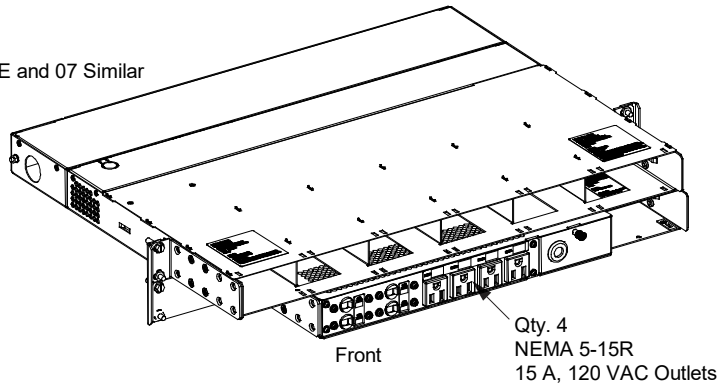
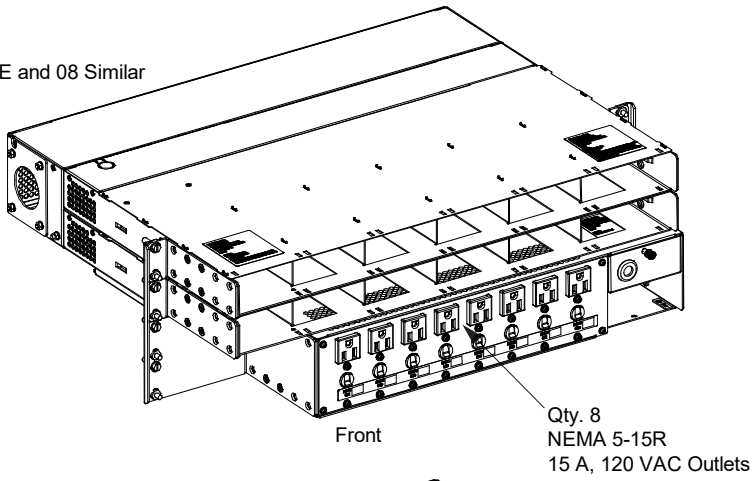

Figure 5.7 Nominal 120 VAC Output Connections, Lists 02, 02E, 04, 04E, 06, 06E, 07, and 08 (NEMA Output)

584130100 List 02  
584130100 List 02E and 07 Similar



584130100 List 04  
584130100 List 04E and 08 Similar



584130100 List 06  
584130100 List 06E Similar

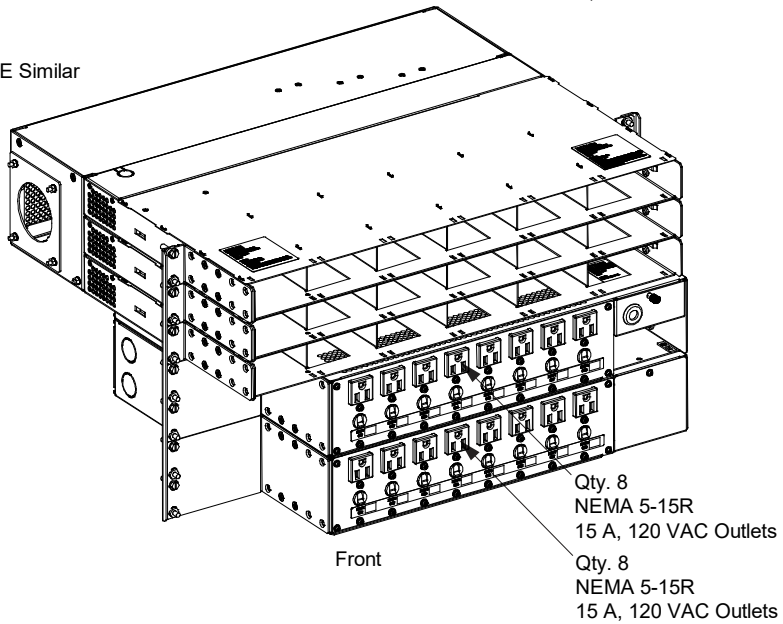

## 5.9 External Alarm, Reference, Monitoring, and Control Connections

The various circuit cards inside the system shelves contain external alarm, reference, monitoring, and control connectors.

### 5.9.1 External alarm, reference, monitoring, and control connection locations

Refer to Figure 5.8.

**Figure 5.8 External Alarm, Reference, Monitoring, and Control Connections Locations**

584130100 List 01 Shown.  
Other Configurations Similar.

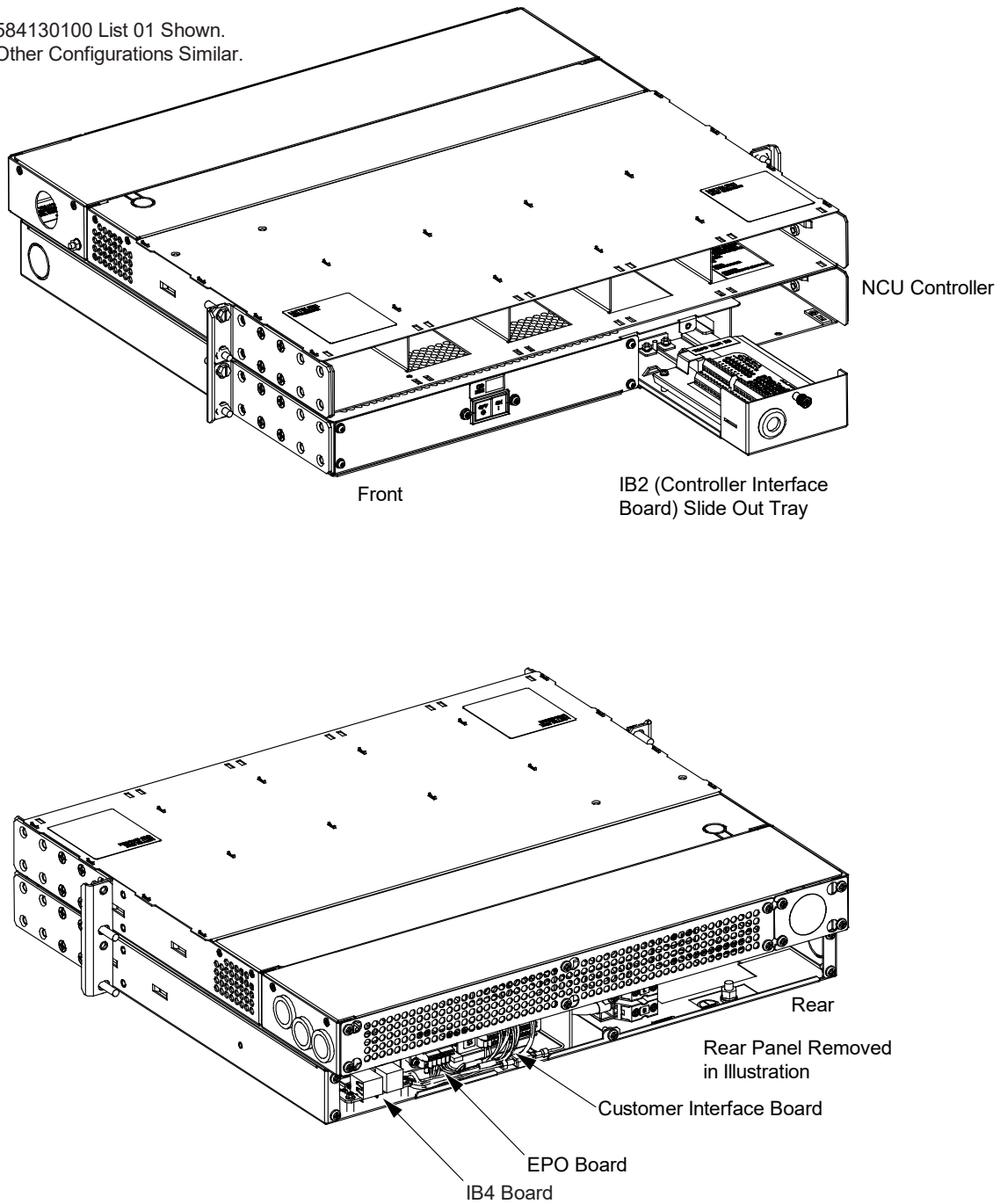

## 5.9.2 IB2 (controller interface board) connections (if required)

The IB2 (Controller Interface Board) provides connection points for digital inputs, programmable relay outputs, and temperature probes. The IB2 interface board is mounted inside a slide-out tray in the AC distribution shelf. Refer to Figure 5.8 for location.

### **Programmable Digital Inputs and Relay Outputs**

Digital input and relay output leads are connected to screw-type terminal blocks located on the IB2. Recommended torque for these connections is 2.2 in-lbs. Refer to Figure 5.9 for terminal locations. Refer to Table 5.1 and Table 5.2 for pin-out information.

#### **Digital Inputs**

Connect up to eight (8) digital inputs to the IB2. Note that you must supply both paths for the digital input (either a positive or negative signal and the opposite polarity return path). Observe proper polarity. Refer to Figure 5.9 for terminal locations and Table 5.1 for pin-out information.

The digital inputs can be programmed to provide an alarm when the signal is applied (HIGH) or removed (LOW). Refer to the NCU Instructions (UM1M830BNA) for programming information.

Digital Input Ratings: Refer to the following.

- a) Maximum Voltage Rating: 60V DC.
- b) Active High: > 19V DC.
- c) Active Low: < 1V DC.

The digital inputs may be preprogrammed for specific functions. Refer to the configuration drawing (C-drawing) supplied with your system for your system's specific configuration.



**NOTE!** Digital Input #8 (-) and Digital Input #8 (+) are used for the EPO (Emergency Power Off) Function. See "EPO (Emergency Power Off) Function" on 25.

#### **Programmable Relay Outputs**

The IB2 provides eight (8) programmable alarm relays with dry Form-C contacts. Connect up to eight (8) relay outputs to the IB2. Refer to Figure 5.9 for terminal locations and Table 5.2 for pin-out information.



**NOTE!** The relay assigned to "Critical Summary" alarm (relay 1 by default) will operate in the "Fail Safe Mode". "Fail Safe Mode" means Relay 1 is de-energized during an alarm condition, opening the contacts between the C and NO terminals, and closing the contacts between the C and NC terminals. The remaining seven (7) relays energize during an alarm condition, closing the contacts between the C and NO terminals, and opening the contacts between the C and NC terminals.

Refer to the NCU Instructions (UM1M830BNA) for programming information.

Relay Ratings: Refer to the following.

- a) Steady State: 0.5 A @ 60V DC; 1.0 A @ 30V DC.
- b) Peak: 3 A @ 30V DC.

The relays may be preprogrammed for specific functions. Refer to the configuration drawing (C-drawing) supplied with your system for your system's specific configuration.

#### **Temperature Probes**



**NOTE!** Each temperature probe consists of two or three pieces that plug together to make a complete probe. See SAG584130100 for part numbers and descriptions.

Up to two (2) temperature probes can be connected to the temperature ports located on the IB2. Refer to Figure 5.9 for temperature port locations.

The temperature probes can be programmed to monitor ambient temperature and/or battery temperature.

The temperature sensor end of the probe contains a tab with a 5/16" clearance hole for mounting.

A temperature probe programmed to monitor battery temperature should be mounted on the negative post of a battery cell to sense battery temperature. A temperature probe programmed to monitor ambient temperature should be mounted in a convenient location, away from direct sources of heat or cold.

**Figure 5.9 IB2 (Controller Interface Board) Connections**

The relay assigned to "Critical Summary" alarm (relay 1 by default) will operate in the "Fail Safe Mode". "Fail Safe Mode" means Relay 1 is de-energized during an alarm condition, opening the contacts between the C and NO terminals, and closing the contacts between the C and NC terminals. The remaining seven (7) relays energize during an alarm condition, closing the contacts between the C and NO terminals, and opening the contacts between the C and NC terminals.

Not all I/O points may be available for customer connection (some may be used for factory system connections). The digital inputs and relay outputs may be preprogrammed for specific functions. Refer to the configuration drawing (C-drawing) supplied with your system for your system's specific configuration.

**J3-J9:**

Wire Size Capacity: 16 AWG to 26 AWG.

Wire Strip Length: 0.20 inch.

Recommended Torque: 2.2 in-lbs.

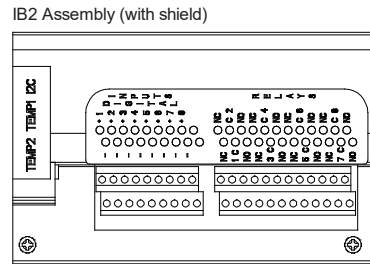

Switch settings must be in this position to interface with the controller.

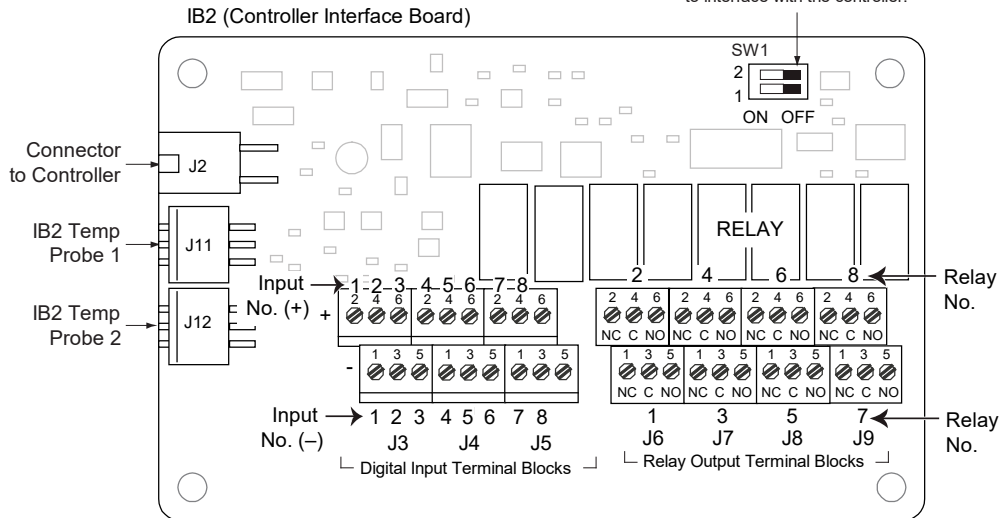

Schematic Diagram of IB2 (Controller Interface Board)

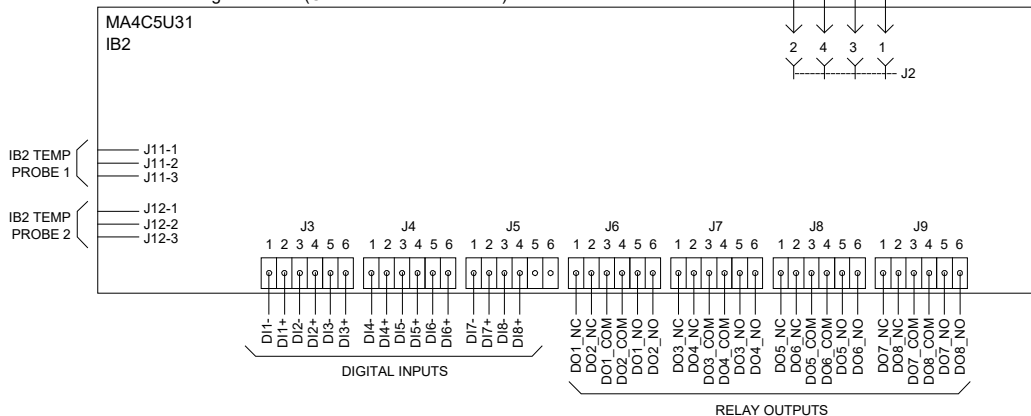



**Table 5.1 Programmable Digital Inputs (Factory Default) – IB2**

Programmable Digital Input	IB2 Pin No.		Factory Wiring	Default Digital Input Function	Notes
IB2-1 DI1	J3-2	+	The digital inputs may be preprogrammed for specific functions and have factory wiring connected. Refer to the configuration drawing (C-drawing) supplied with your system for your system's specific configuration.	The digital inputs may be preprogrammed for specific functions. Refer to the configuration drawing (C-drawing) supplied with your system for your system's specific configuration.	<p><b>Note:</b> Digital Input #8 (-) and Digital Input #8 (+) are used for the EPO (Emergency Power Off) Function. See "EPO (Emergency Power Off) Function" on 25.</p> <p><b>Note:</b> Not all I/O points may be available for customer connection (some may be used for factory system connections). The digital inputs may be preprogrammed for specific functions. Refer to the configuration drawing (C-drawing) supplied with your system for your system's specific configuration.</p>
	J3-1	-			
IB2-1 DI2	J3-4	+			
	J3-3	-			
IB2-1 DI3	J3-6	+			
	J3-5	-			
IB2-1 DI4	J4-2	+			
	J4-1	-			
IB2-1 DI5	J4-4	+			
	J4-3	-			
IB2-1 DI6	J4-6	+			
	J4-5	-			
IB2-1 DI7	J5-2	+			
	J5-1	-			
IB2-1 DI8	J5-4	+	EPO	EPO	
	J5-3	-	EPO		
--	J5-5		DC- (200mA)	--	
--	J5-6		DC+ (0V)		

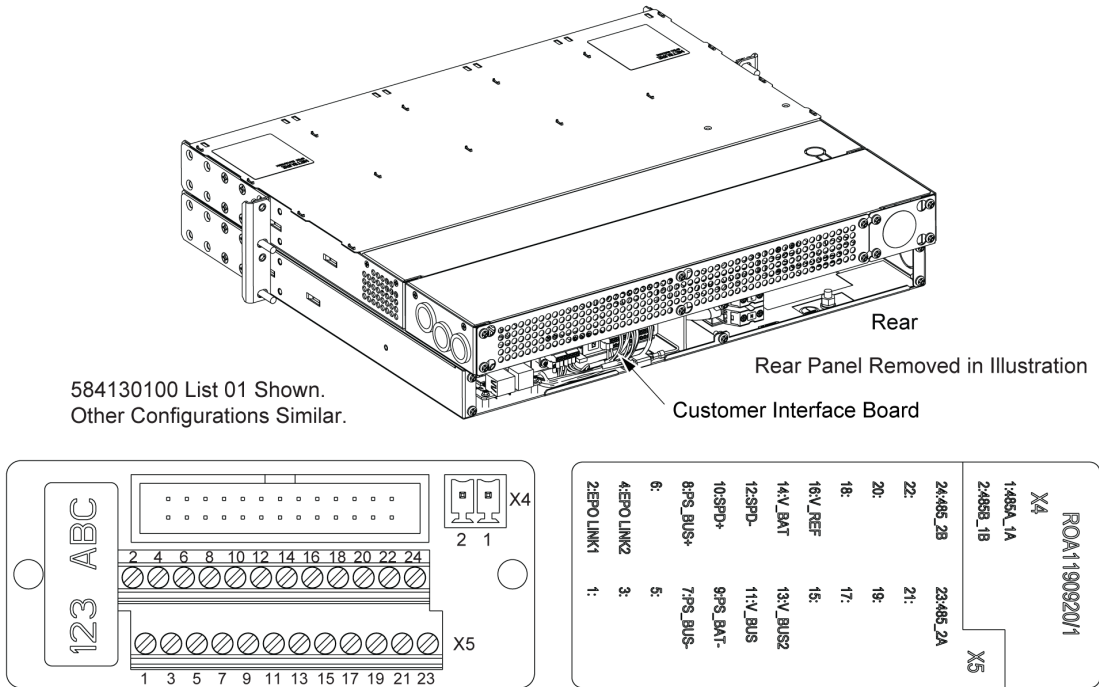

**Table 5.2 Programmable Relay Outputs (Factory Default) – IB2 Board**

Programmable Relay Output		IB2 Pin No.	Alarms Assigned to this Relay (Default)	Notes
IB2-1 DO1	NO	J6-5	The relays may be preprogrammed for specific functions. Refer to the configuration drawing (C-drawing) supplied with your system for your system's specific configuration.	<p><b>Note:</b> The relay assigned to "Critical Summary" alarm (relay 1 by default) will operate in the "Fail Safe Mode". "Fail Safe Mode" means Relay 1 is de-energized during an alarm condition, opening the contacts between the C and NO terminals, and closing the contacts between the C and NC terminals. The remaining seven (7) relays energize during an alarm condition, closing the contacts between the C and NO terminals, and opening the contacts between the C and NC terminals.</p> <p><b>Note:</b> Not all I/O points may be available for customer connection (some may be used for factory system connections). The relay outputs may be preprogrammed for specific functions. Refer to the configuration drawing (C-drawing) supplied with your system for your system's specific configuration.</p>
	COM	J6-3		
	NC	J6-1		
IB2-1 DO2	NO	J6-6		
	COM	J6-4		
	NC	J6-2		
IB2-1 DO3	NO	J7-5		
	COM	J7-3		
	NC	J7-1		
IB2-1 DO4	NO	J7-6		
	COM	J7-4		
	NC	J7-2		
IB2-1 DO5	NO	J8-5		
	COM	J8-3		
	NC	J8-1		
IB2-1 DO6	NO	J8-6		
	COM	J8-4		
	NC	J8-2		
IB2-1 DO7	NO	J9-5		
	COM	J9-3		
	NC	J9-1		
IB2-1 DO8	NO	J9-6		
	COM	J9-4		
	NC	J9-2		

### 5.9.3 Customer Interface Board Connections – MANDATORY WIRING FOR SYSTEM OPERATON!!

Figure 5.10 Customer Interface Board Connections



#### REQUIRED CONNECTIONS

The following connections from the Customer Interface Board to the appropriate termination points are **REQUIRED** for the inverter system to operate properly. All connections should be discrete and **NOT** combined - use 24-gauge wire.

Function: Powers the NCU

Connections:

- From PS\_BUS- (X5 pin 7) to system negative busbar
- From PS\_BUS+ (X5 pin 8) to system positive busbar
- From PS\_BAT- (X5 pin 9) to battery negative busbar

Function: Reference Voltages for System Operation

Connections:

- From V\_BUS1 (X5 pin 11) to system positive busbar
- From V\_BUS2 (X5 pin 13) to system positive busbar
- From V\_BAT- (X5 pin 14) to battery negative busbar (if BLVD is present, terminate on battery side of BLVD)
- From V\_REF- (X5 pin 16) to system negative busbar

Function: Emergency Power Off

Connections:

- EPO\_LINK 1 (X5 pin 2) factory connected to EPO\_LINK 2 (X5 pin 4)

Notes:

- Link closed = normal operation
- Link open = EPO activated
- Customer can replace the EPO link with a normally closed emergency switch on site

#### OPTIONAL CONNECTIONS

The following are optional connections to the Customer Interface Board:

Function: Southbound MODBUS

Connections:

- RS485+\_1 (X4 pin 1)
- RS485-\_1 (X4 pin 2)

Function: Northbound MODBUS

Connections:

- RS485+\_2 (X5 pin 23)
- RS485-\_2 (X5 pin 24)

Function: Digital Input for Surge Protection Device

Connections:

- SPD+ (X5 pin 10)
- SPD- (X5 pin 12)

Notes:

- Relay switch state detection - NC dry contact

**EPO (Emergency Power Off) Function**

The inverter system contains an EPO (Emergency Power Off) function. Connection points for a normally closed external EPO switch are provided on the customer interface board. If an external EPO switch is wired to the customer interface board, activating the switch to open the circuit activates the EPO function. The EPO function shuts down and locks out the inverters. When the EPO switch is returned to normal (closed loop), the inverters remain off. The inverters will restart when the AC and DC power inputs are removed and restored after 30 seconds or more (until the LEDs on the modules extinguish) (depending on the synchronizing time with the system). (Note that there is an EPO shorting link factory installed that can be replaced with a customer provided switch.)



**NOTE!** *If a customer-furnished method to disconnect the AC and DC power inputs to the system is not provided, the inverters will stay locked OFF until the input power is recycled. If the EPO switch is returned to normal (closed loop) without recycling the input power, the inverters will remain off and have a local alarm visible on the module. The EPO alarm from the controller will extinguish. The controller will not issue an alarm for this condition.*

## 5.10 NCU Controller Ethernet Connection (if required)

The controller provides a Web Interface via an Ethernet connection to a TCP/IP network. This interface can be accessed locally on a computer and/or remotely through a network. The system has two Ethernet ports. One located on the NCU front panel and the other located on the IB4 board. The function of these Ethernet ports are as follows.

### NCU Front Panel Ethernet Port

An RJ-45 10BaseT jack is provided on the front of the controller for connecting a computer directly to the NCU. This jack has a standard Ethernet pin configuration scheme, twisted pair. Refer to Figure 5.11 for location and Table 5.3 for pin outs. Refer to the NCU Instructions (UM1M830BNA) for operational details. Default address: 192.168.100.100.

**NOTE!** You can access the Web pages of the system locally by using a "crossover" or "straight" cable connected directly between your PC and the controller.

**NOTE!** DO NOT connect your Local Area Network (LAN) to the NCU front Ethernet port.

Figure 5.11 NCU Ethernet Port (to connect a computer directly to the NCU)

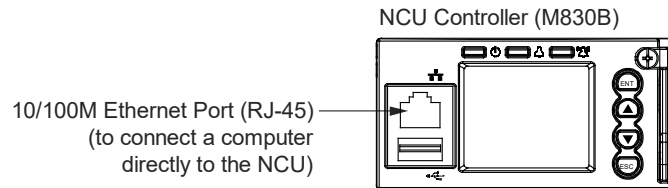

Table 5.3 RJ-45 Ethernet Port Pin Configuration

Port Pin Number	Name	Definition
1	Tx+	Write Signal +
2	Tx-	Write Signal -
3	Rx+	Read Signal +
4	--	no connection
5	--	no connection
6	Rx-	Read Signal -
7	--	no connection
8	--	no connection

### IB4 Board Ethernet Port

An RJ-45 10BaseT jack is provided on the IB4 board for connection into a customer's network. Use this Ethernet port to connect the NCU to your Local Area Network (LAN). This jack has a standard Ethernet pin configuration scheme, twisted pair. Refer to Figure 5.8 for IB4 board location. Refer to Figure 5.12 for Ethernet port location and Table 5.3 for pin outs. Use shielded Ethernet cable (grounded at both ends). Note that the IB4 board's RJ-45 jack is connected to chassis ground. Refer to the NCU Instructions (UM1M830BNA) for operational details.



**WARNING!** The intra-building port(s) of the equipment or subassembly is suitable for connection to intra-building or unexposed wiring or cabling only. The intra-building port(s) of the equipment or subassembly **MUST NOT** be metalically connected to the interfaces that connect to the OSP or its wiring. These interfaces are designed for use as intra-building interfaces only (Type 2 or Type 4 ports as described in GR-1089-CORE, Revision 4) and require isolation from the exposed OSP cabling. The addition of Primary Protectors is not sufficient protection in order to connect these interfaces metalically to OSP wiring.

The intra-building port (RJ-45) of the equipment or subassembly must use shielded intra-building cabling/wiring that is grounded at both ends.

#### **Default IB4 Ethernet Port Parameters**

<u>IPv4</u>		<u>IPv6</u>	
IP Address:	192.168.1.2	IPv6 Address:	20fa:fffd:ffc:ffb:ffa:ff9:fff8:fff7
Subnet Mask:	255.255.255.0	IPv6 Prefix:	0
Default Gateway:	192.168.1.1	IPv6 Gateway:	20fa:1:ffe:fff:ffe:ffd:fff:ffe

**Figure 5.12 IB4 Board Ethernet Port (to connect Local Area Network [LAN])**

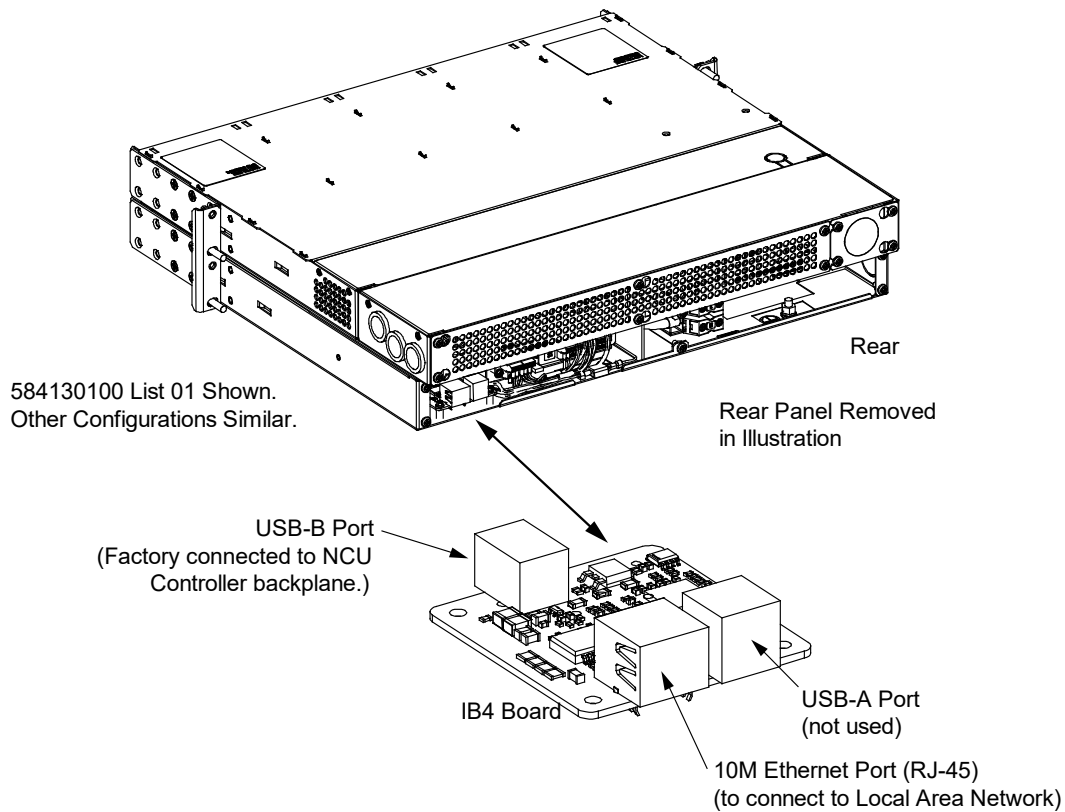

## 6 Installing Inverter Modules

Inverter modules can be inserted or removed with power applied (hot swappable).

**NOTE!** Each inverter module locks into the module mounting shelf by means of a latch located on the bottom of the inverter module. The latch and inverter module handle are interactive. Pushing the handle up into the inverter module's front panel causes the latch to extend to the locking position; pulling the handle down out from the inverter module's front panel causes the latch to retract. See Figure 6.1.

**WARNING!** To prevent damage to the latching mechanism, ensure the handle is in the open position when installing or removing an inverter module. NEVER hold the handle in the closed position when installing an inverter module into a shelf.

### Procedure

1. Unpack the inverter modules.
2. If present, remove blank cover panels from the module mounting positions into which inverter modules are to be installed.
3. Place the inverter module into an unoccupied mounting position without sliding it in completely.
4. Loosen the captive screw on the inverter module's handle. Pull the handle down out from the inverter module's front panel (this will also retract the latch mechanism). See Figure 6.1.
5. Push the inverter module completely into the shelf.
6. Push the handle up into the inverter module's front panel. This will lock the inverter module securely to the shelf. Tighten the captive screw on the handle.
7. Repeat the above steps for each inverter module being installed in the system.
8. After the inverter modules are physically installed in the mounting shelf(s), they are ready for operation within 60 seconds after power is supplied to them.

Figure 6.1 Installing Inverter Modules

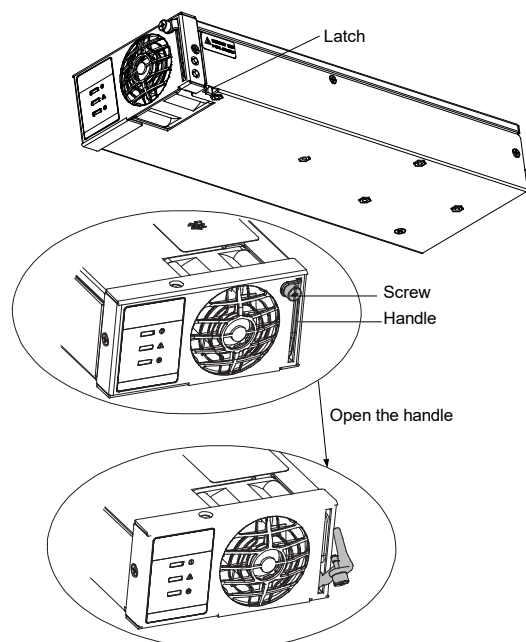

## 7 Initially Starting and Checking System Operation



**CAUTION!** Performing various steps in the following procedures may cause a service interruption and/or result in the extension of alarms. Notify any appropriate personnel before starting these procedures. Also, notify personnel when these procedures are completed.

### 7.1 Initial Startup Preparation

- Ensure that all blocks (except the last one) in the “Installation Acceptance Checklist” on page 2 have been checked.
- Ensure that inverter module mounting positions are filled by an inverter module or a blank panel as required.
- Verify all inverter modules and the controller are fully seated, latched, and the latch handle screws secured.
- Refer to the separate NCU User Manual supplied with your system for complete controller operating information.
- Refer to the configuration drawing (C-drawing) supplied with your system documentation for factory settings of adjustable parameters.

### 7.2 Initially Starting the System

#### Procedure

1. Apply DC input power to the system by closing ALL external DC disconnects or protective devices that supply DC power to the system.
2. Apply AC input power (if furnished) to the system by closing ALL external AC disconnects or protective devices that supply AC power to the system.
3. Inverter modules automatically start.
4. Place each circuit breaker located on the AC distribution shelf(s) to the ON position.

### 7.3 NCU Controller Initialization

#### Procedure



**NOTE!** The initialization routine takes several minutes. During that time various alarm indicators may illuminate on the NCU front panel and an audible alarm may sound. Disregard all alarms. An audible alarm can be silenced at any time by momentarily depressing the ENT key on the NCU Controller.

1. After the NCU is powered on, the display shows the logo screen. The controller is initializing.
2. When initialization is complete, the language screen appears. Press the UP or DOWN arrow key to select the desired language. Press the ENT key to confirm the selection. Refer to Figure 7.1 for locations of the NCU local indicators and navigation keys.
3. The Main Menu displays.
4. The NCU is factory configured for use with this inverter system and no adjustment is required. Refer to the separate NCU User Manual supplied with your system for complete controller operating information.

Figure 7.1 NCU Local Indicators and Navigation Keys

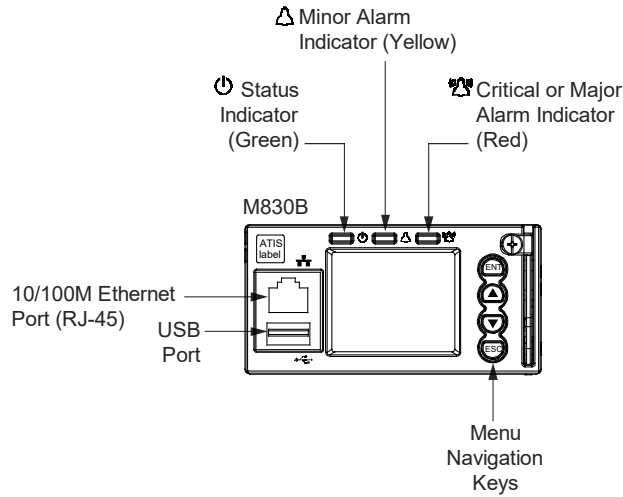







## 7.4 Checking System Status

### Procedure

1. Observe the status of the indicators located on the controller and inverters. If the system is operating normally, the status of these is as shown in Table 7.1.
2. Verify there are no external alarms, and the local indicators are as shown in Table 7.1.

Table 7.1 Status and Alarm Indicators

Component	Indicator	Indicator	Normal State
NCU		Status (Green)	On
		Minor Alarm (Yellow)	Off
		Critical or Major Alarm (Red)	Off
Inverter Modules		Power (Green)	On
		Protection (Yellow)	Off
		Alarm (Red)	Off



## Connect with Vertiv on Social Media



<https://www.facebook.com/vertiv/>



<https://www.instagram.com/vertiv/>



<https://www.linkedin.com/company/vertiv/>



<https://www.twitter.com/vertiv/>



---

Vertiv.com | Vertiv Headquarters, 505 N Cleveland Ave, Westerville, OH 43082, USA

© 2024 Vertiv Group Corp. All rights reserved. Vertiv™ and the Vertiv logo are trademarks or registered trademarks of Vertiv Group Corp. All other names and logos referred to are trade names, trademarks or registered trademarks of their respective owners. While every precaution has been taken to ensure accuracy and completeness here, Vertiv Group Corp. assumes no responsibility, and disclaims all liability, for damages resulting from use of this information or for any errors or omissions.