



NetSure™ 7100 -48 VDC Power System

User Manual

Specification Number: 582127000600, 582127000601, 582127000900, 582127000901, 582127000930, 582127000931
Model Number: 7100

The information contained in this document is subject to change without notice and may not be suitable for all applications. While every precaution has been taken to ensure the accuracy and completeness of this document, Vertiv assumes no responsibility and disclaims all liability for damages resulting from use of this information or for any errors or omissions. Refer to other local practices or building codes as applicable for the correct methods, tools, and materials to be used in performing procedures not specifically described in this document.

The products covered by this instruction manual are manufactured and/or sold by Vertiv. This document is the property of Vertiv and contains confidential and proprietary information owned by Vertiv. Any copying, use or disclosure of it without the written permission of Vertiv is strictly prohibited.

Names of companies and products are trademarks or registered trademarks of the respective companies. Any questions regarding usage of trademark names should be directed to the original manufacturer.

Technical Support Site

If you encounter any installation or operational issues with your product, check the pertinent section of this manual to see if the issue can be resolved by following outlined procedures.

Visit <https://www.vertiv.com/en-us/support/> for additional assistance.

TABLE OF CONTENTS

Admonishments Used in this Document	iv
Important Safety Instructions	v
1 Customer Documentation Package	1
2 System Description	2
2.1 Lists 600, 601, 900, and 901.....	2
2.2 Lists 930 and 931.....	3
3 Physical Security	4
4 Operating Procedures	5
4.1 Controller and Rectifiers/Converters.....	5
4.2 ESTOP Function.....	5
4.3 Controller Battery Charge Current Limit Feature.....	5
4.4 Local Controls and Indicators.....	5
4.4.1 Controller and Rectifiers/Converters.....	5
4.4.2 System Alarm Indicator.....	6
4.4.3 Circuit Cards.....	6
5 Maintenance	12
5.1 Important Safety Instructions.....	12
5.2 System Maintenance Procedures.....	12
5.3 Adding a Rectifier Module to an Empty Module Mounting Position.....	12
5.4 Adding a Converter Module to an Empty Module Mounting Position.....	12
5.5 Installing Optional EIB (Controller Extended Interface Board).....	12
5.6 Reconfiguring Dual Voltage Panel (Lists 930, 931).....	13
6 Troubleshooting and Repair	15
6.1 Important Safety Instructions.....	15
6.2 Contact Information.....	15
6.3 Controller and Rectifiers/Converters.....	15
6.4 Controller Configuration.....	15
6.5 System Troubleshooting Information.....	15
6.6 Replacement Information.....	16
6.7 Replacement Procedures.....	16
6.7.1 Replacing a Rectifier or Converter Module.....	16
6.7.2 Replacing the NCU Controller.....	16
6.7.3 Replacing a Distribution Device.....	16
6.7.4 Circuit Card Replacement Procedures.....	19
6.7.5 Replacing the Distribution Panel.....	26
6.7.1 Replacing a Battery Disconnect Contactor (if furnished).....	29

Admonishments Used in this Document



DANGER! Warns of a hazard the reader *will* be exposed to that will *likely* result in death or serious injury if not avoided. (ANSI, OSHA)



WARNING! Warns of a potential hazard the reader *may* be exposed to that *could* result in death or serious injury if not avoided. This admonition is not used for situations that pose a risk only to equipment, software, data, or service. (ANSI)



CAUTION! Warns of a potential hazard the reader *may* be exposed to that *could* result in minor or moderate injury if not avoided. (ANSI, OSHA) This admonition is not used for situations that pose a risk only to equipment, data, or service, even if such use appears to be permitted in some of the applicable standards. (OSHA)



ALERT! Alerts the reader to an action that *must be avoided* in order to protect equipment, software, data, or service. (ISO)



ALERT! Alerts the reader to an action that *must be performed* in order to prevent equipment damage, software corruption, data loss, or service interruption. (ISO)



FIRE SAFETY! Informs the reader of fire safety information, reminders, precautions, or policies, or of the locations of fire-fighting and fire-safety equipment. (ISO)



SAFETY! Informs the reader of general safety information, reminders, precautions, or policies not related to a particular source of hazard or to fire safety. (ISO, ANSI, OSHA)

Important Safety Instructions

Safety Admonishments Definitions

Definitions of the safety admonishments used in this document are listed under “Admonishments Used in this Document” on page iv.

Safety and Regulatory Statements

Refer to Section 4154 (provided with your customer documentation) for Safety and Regulatory Statements.

Déclarations de Sécurité et de Réglementation

Reportez-vous à la Section 4154 (fourni avec les documents de votre client) pour les déclarations de sécurité et de réglementation.

This page intentionally left blank.

1 Customer Documentation Package

This document (UM582127000900) provides *User Instructions* for Vertiv™ NetSure™ 7100 -48 VDC Power System, Spec. No. 582127000; Lists 600, 601, 900, 901, 930, and 931.

The complete Customer Documentation Package for Lists 600, 601, 900, 901, 930, and 931 consists of...

-48 VDC Power System Installation Manual

- Power System Installation Instructions: IM582127000900

-48 VDC Power System User Manual

- Power System User Instructions: UM582127000900

NCU Controller User Manual

- NCU Controller User Instructions: UM1M830BNA

USB Drive with All Customer Documentation

Applicable documents for this system are as follows.

- Power System Installation Instructions: IM582127000900 (instructions for Lists 600, 601, 900, 901, 930, and 931)
- Power System User Instructions: UM582127000900 (instructions for Lists 600, 601, 900, 901, 930, and 931)
- NCU Controller User Instructions: UM1M830BNA
- Rectifier Instructions: UM1R483500e3
- Converter Instructions: UM1C48583750P4 and UM1C48582000P3
- Power System "System Application Guide": SAG582127000
- Engineering Drawings
- Also, provided on the USB drive is a controller configuration drawing and the controller configuration files loaded into the controller as shipped.

2 System Description

Refer to this section for descriptions of the power system.

2.1 Lists 600, 601, 900, and 901

-48 VDC @ up to 900 Amperes Power System

Lists 600, 601, 900, and 901 of Vertiv™ NetSure™ 7100 DC Power System (Spec. No 582127000) is an integrated power system containing -48 VDC rectifiers, intelligent control, metering, monitoring, and distribution.

This power system is designed to power a load while charging a positive grounded battery. This power system is capable of operating in a batteryless installation or off battery for maintenance purposes. The power system is designed for operation with the positive output grounded.

This system is designed to be installed on a rack in an enclosure.

Lists 600, 601, 900, and 901 of Vertiv™ NetSure™ 7100 DC Power System (Spec. No 582127000) consists of the following components.

Distribution Cabinet

A 2-row distribution cabinet is provided. Installed in the distribution cabinet are two (2) 26-position load distribution panels which accept bullet nose type circuit breakers and TPS/TLS fuseholders.

The distribution cabinet also houses one (1) IB2 controller interface board, one (1) optional EIB controller extended interface board, the IB5 second Ethernet port board, and the system interface board.



NOTE! *IB5 boards with a 10M/100M/1G Ethernet port replaced IB4 boards with a 10M/100M Ethernet port. This transition enables the support of connected devices that communicate up to 1G. While both boards are physically interchangeable, the IB5 board does require the NCU to have V1.2.80 or higher software loaded.*

582127000 List 600 and List 900 are equipped with low voltage battery disconnect (LVBD).

NCU Controller

The controller provides power system control (including low voltage battery disconnect (LVBD) in List 600 and List 900), rectifier control (including a charge control function), metering functions, monitoring functions, and local/remote alarm functions. The controller also supports rectifier temperature compensation if the system is equipped with a temperature probe(s). Temperature probe(s) may also be designated to monitor ambient temperature and/or battery temperature. The controller also provides data acquisition, system alarm management, and advanced battery and energy management. The controller contains a color LCD display and keypad for local access. The controller provides an Ethernet port and comes with comprehensive webpages for remote access. The controller has SNMP v3 capability for remote system management. The controller supports software upgrade via its USB port. Refer to the NCU Controller Instructions (UM1M830BNA) for more information.

Rectifier Modules

The system contains rectifier modules, which provide load power, battery float current, and battery recharge current during normal operating conditions. Refer to the Rectifier Instructions (UM1R483500e3) for more information.

2.2 Lists 930 and 931

-48 VDC @ up to 900 Amperes / -58 VDC @ up to 600A Peak, 500A Average Dual Voltage Power System

Lists 930 and 931 of Vertiv™ NetSure™ 7100 DC Power System (Spec. No 582127000) is an integrated dual voltage power system containing -48 VDC rectifiers, -48 VDC to -58 VDC converters, intelligent control, metering, monitoring, and distribution.

This power system is designed to power a load while charging a positive grounded battery. This power system is capable of operating in a batteryless installation or off battery for maintenance purposes. The power system is designed for operation with the positive output grounded.

This system is designed to be installed on a rack in an enclosure.

Lists 930 and 931 of Vertiv™ NetSure™ 7100 DC Power System (Spec. No 582127000) consists of the following components.

Distribution Cabinet

A 2-row distribution cabinet is provided. Installed in the distribution cabinet are two (2) 30-position load distribution panels which accept bullet nose type circuit breakers and TPS/TLS fuseholders.

The system consists of sixty (60) DC Load distribution positions for bullet-type devices, seventeen (17) total positions for 1R483500E3 and 1R483600E4 -48V rectifiers, twelve (12) positions for 1C48582000P3 and/or 1C48583750P4 -48 VDC to -58 VDC converters, and IB2 board, and IB5 board, an interface board, and a position for the NCU controller. Optional equipment includes low voltage battery disconnect, second IB2 board, Extended Interface Board (EIB), GMT fuse module, DC generator input kit, and temperature probes. It is intended for mounting in an enclosure with 27" mounting width or on shipping rails for field mounting into an enclosure.

582127000 List 930 is equipped with low voltage battery disconnect (LVBD).

NCU Controller

The controller provides power system control (including low voltage battery disconnect (LVBD) in List 930), rectifier control (including a charge control function), converter control, metering functions, monitoring functions, and local/remote alarm functions. The controller also supports rectifier temperature compensation if the system is equipped with a temperature probe(s). Temperature probe(s) may also be designated to monitor ambient temperature and/or battery temperature. The controller also provides data acquisition, system alarm management, and advanced battery and energy management. The controller contains a color LCD display and keypad for local access. The controller provides an Ethernet port and comes with comprehensive webpages for remote access. The controller has SNMP v3 capability for remote system management. The controller supports software upgrade via its USB port. Refer to the NCU Controller Instructions (UM1M830BNA) for more information.

Rectifier Modules

The system contains rectifier modules, which provide load power, battery float current, and battery recharge current during normal operating conditions. Refer to the Rectifier Instructions (UM1R483500E3 or UM1R483600E4) for more information.

Converter Modules

The system contains -48 VDC to -58 VDC converter modules. Refer to the Converter Instructions (UM1C48582000P3 or UM1C48583750P4) for more information.

3 Physical Security

This product is designed and intended to be deployed and operated in a physically secure and network firewall-protected location. Vertiv recommends a review of the physical security and operating environment of the unit. Since an attacker or disgruntled user can cause serious disruption, below are some recommended best practices that include, but are not limited to:

- Restrict access to areas, racks, and units with encrypted card RFID/badges, unique multi-factor passcode authentication for access, man traps, and biometric scanners for physical access to the equipment.
- Have trusted and background-checked security guards with 24x7x365 physical presence and written logs to help document and note physical access to a data center, building, rack, and so on.
- Restrict physical access to telecommunications equipment and network cabling. Physical access to the telecommunications lines and network cabling should be restricted to protect against attempts to intercept or sabotage communications. Best practices include use of metal conduits for the network cabling running between equipment cabinets.
- All USB, RJ45, and/or any other physical ports should be restricted on the units.
- Do not connect removable media (such as USB devices, SD cards, and so on) for any operation (such as firmware upgrade, configuration change, or boot application change) unless the origin of media is known and trusted. Before connecting any portable device through a USB port or SD card slot, scan the device for malware and viruses.

4 Operating Procedures

4.1 Controller and Rectifiers/Converters

For operation instructions on these units, refer to the following documents.

- NCU Controller Instructions (UM1M830BNA)



NOTE! The controller's default "User Name" is "admin" and the default "Password" is "640275".

- Rectifier Instructions (UM1R483500e3)
- Converter Instructions (UM1C48583750P4 and UM1C48582000P3)

4.2 ESTOP Function

If an ESTOP switch is wired to the IB2, customer-furnished system ground applied to terminal DI8+ activates the ESTOP function. The ESTOP function shuts down and locks out the rectifiers and opens the low voltage battery disconnect contactor (if furnished). If the system has battery connected and does not contain a low voltage battery disconnect contactor or the controller power option is set to Battery Pwr (jumper J4 on the system interface board is set to Battery Pwr), the controller will remain operational. If the system has battery connected and does not contain a low voltage battery disconnect contactor, the loads will be sustained by the battery voltage.

When the ESTOP signal is removed, the low voltage battery disconnect contactor (if furnished) remains open. Rectifiers remain off. The rectifiers restart when input power is removed and restored after 30 seconds or more (until the LEDs on the modules extinguish). When the rectifiers restart, the low voltage battery disconnect contactor closes (if furnished).



NOTE! If a customer-furnished method to disconnect the input power to the system is not provided, the rectifiers will stay locked OFF until the input power is recycled. If the ESTOP signal is removed without recycling the input power, the rectifiers will remain off and have a local alarm visible on the module. The ESTOP alarm from the controller will extinguish. The controller will not issue an alarm for this condition.

4.3 Controller Battery Charge Current Limit Feature

Functionality: After a failure of the input source (commercial AC) or when some battery cells are permanently damaged, the current to the batteries can be quite extensive. To avoid overheating or further damages to the battery, the controller can be programmed to limit the battery current to a preset level by limiting the charging voltage of the rectifiers. Should the battery current still exceed a higher preset value, an alarm is issued.

The controller limits the current going to the batteries based on the "Battery Current Limit" set point which is a percentage of the battery capacity in C10. For example, 0.1C10 would mean 10% of the battery capacity. If the C10 capacity of a battery is 100 amp-hr, the battery recharge current limiting set point is 0.1C10; therefore, the recharge current is limited to 10 A.

Refer to the NCU Controller Instructions (UM1M830BNA) to program this feature. Battery charge current is limited to the value set in the controller, as long as battery voltage is above 47 VDC. The default value for battery recharge current limit is 0.1xC10.

4.4 Local Controls and Indicators

4.4.1 Controller and Rectifiers/Converters

Refer to the controller and rectifier and converter instructions for descriptions of the local controls and indicators located on these units.

4.4.2 System Alarm Indicator

Visible on the front door is an alarm indicator which illuminates if the NCU controller issues a system alarm. The system alarm indicator can be programmed to illuminate due to any alarm level (Critical, Critical/Major, or Critical/Major/Minor). See “System Alarm Function” in the NCU Controller User Manual (UM1M830BNA).

4.4.3 Circuit Cards

Refer to this section for descriptions of the jumpers and/or switches located on the circuit cards installed in the distribution cabinet.

Circuit Card Locations (Lists 600, 601, 900, and 901)

Refer to Figure 4.1.

Figure 4.1 Circuit Card Locations (Lists 600, 601, 900, and 901)

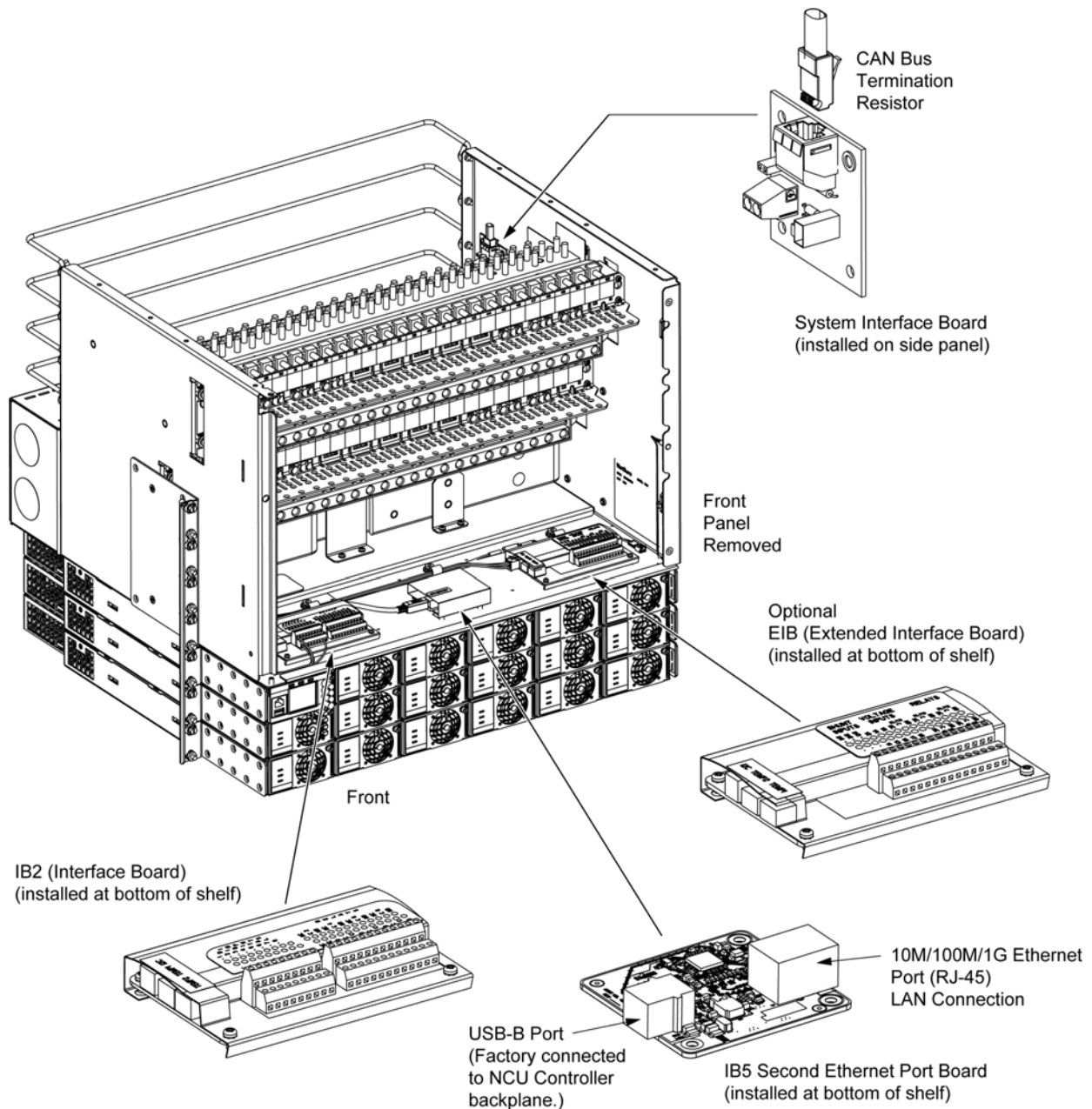

Circuit Card Locations (Lists 930, and 931)

Refer to Figure 4.2.

Figure 4.2 Circuit Card Locations (Lists 930, and 931)

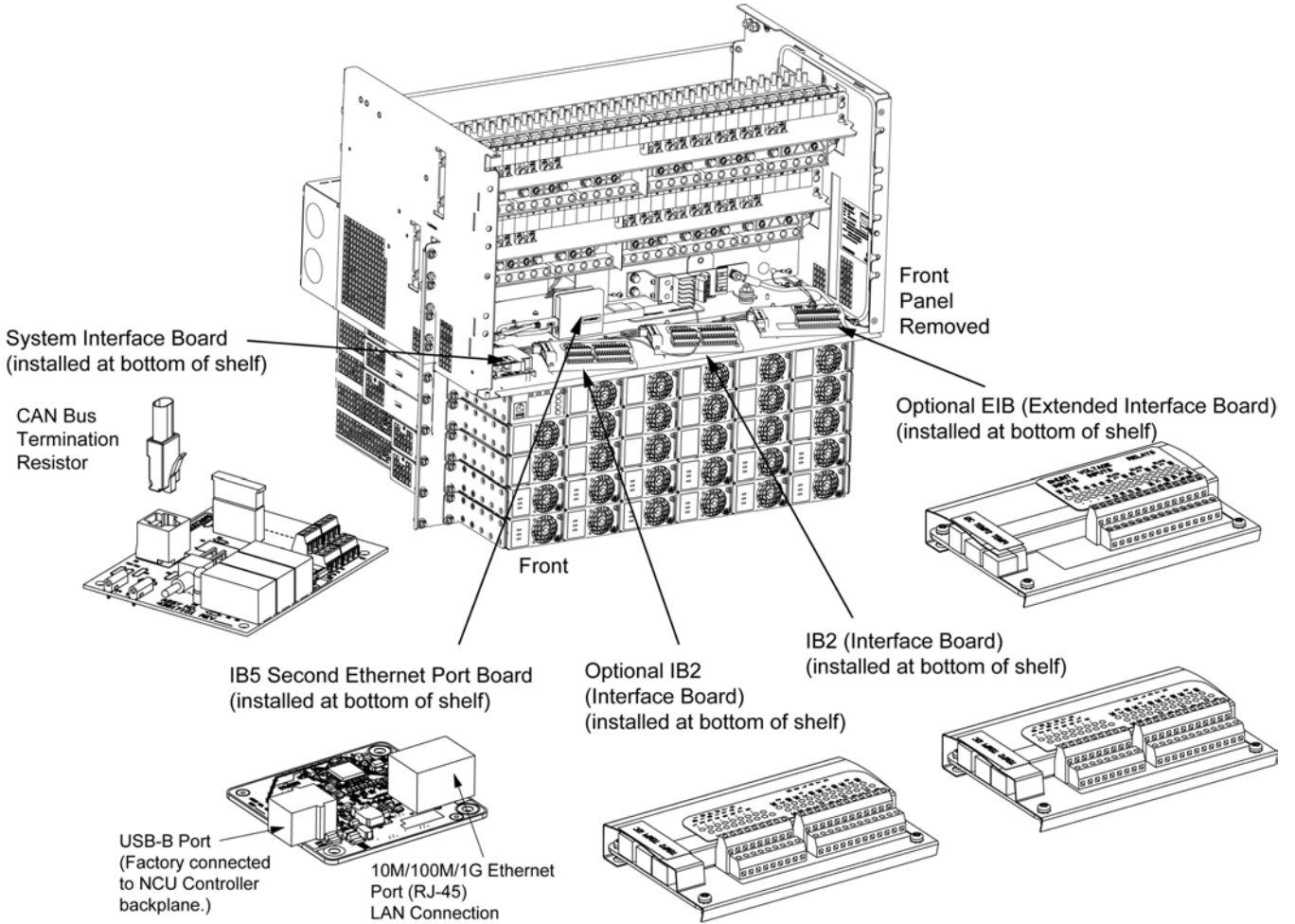

System Interface Circuit Card (Lists 600, 601, 900, and 901)

The system interface circuit card for Lists 600, 601, 900, and 901 contains a CAN port, a jumper, and an RS-485 terminal block. Refer to the System Installation Manual IM582127000900 for details. Refer to Figure 4.1 for circuit card location and Figure 4.3 for a circuit card illustration.

Figure 4.3 System Interface Circuit Card (Lists 600, 601, 900, 901)

A CAN termination plug (P/N 548398) must be installed if an external device or system is not connected here.

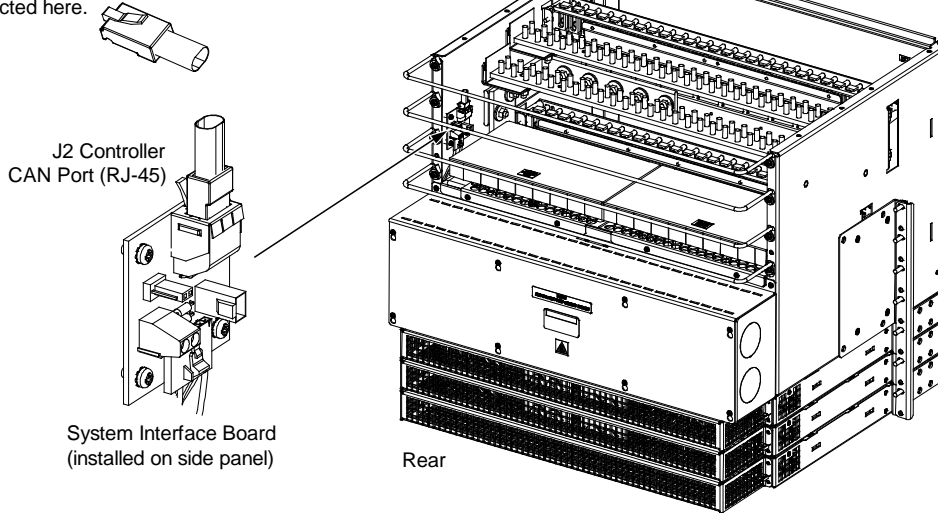

J4 on System Interface Board

Selects to power controller from "Battery Power" or not if a battery LVD contactor is furnished.

No
Battery Battery
Pwr Pwr

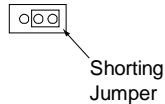

J3 on System Interface Board

Wire Size Capacity: 16 AWG to 30 AWG.
Wire Strip Length: 0.32 inch.
Recommended Torque: 2.3 in-lbs.

RS485 Connection

J3-1: RS485+
J3-2: RS485-

System Interface Board P/N 555484

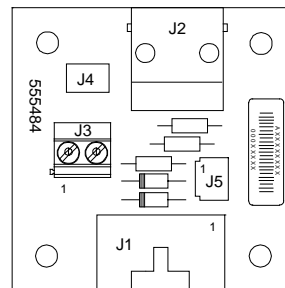

System Interface Circuit Card (Lists 930 and 931)

The system interface circuit card for Lists 930 and 931 contains a CAN port, a jumper, and an RS-485 terminal block. Refer to the System Installation Manual IM582127000900 for details. Refer to Figure 4.2 for circuit card location and Figure 4.4 for a circuit card illustration.

Figure 4.4 System Interface Circuit Card (Lists 930 and 931)

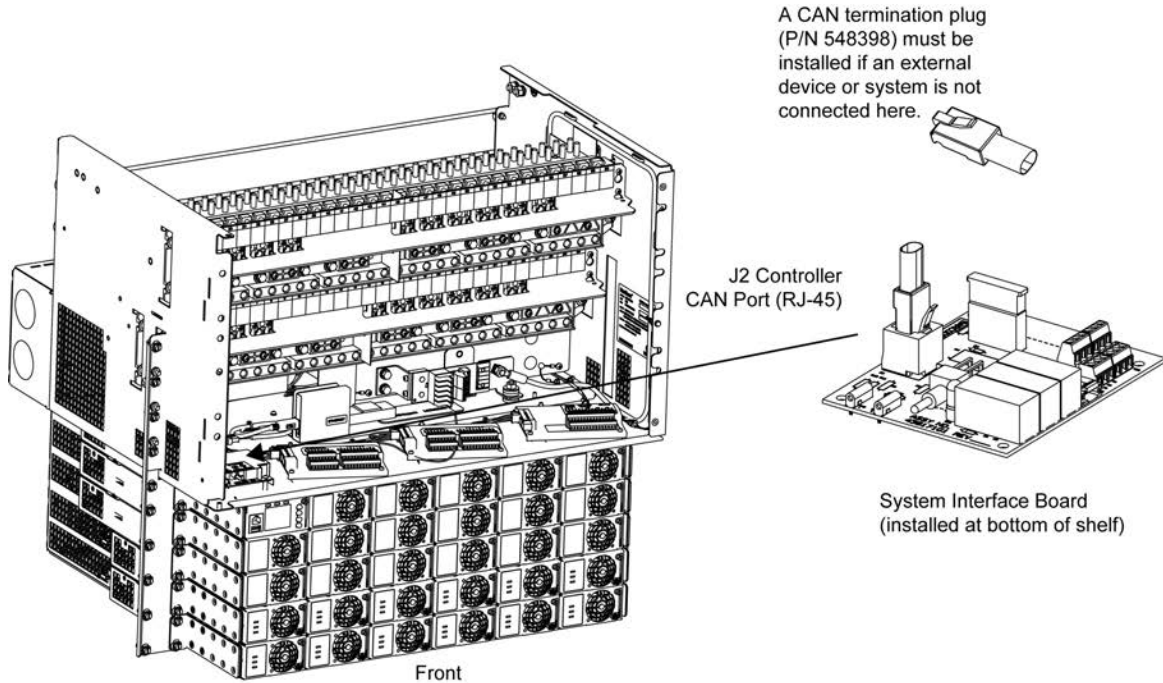

System Interface Board P/N 430171G1

The MAX fuse installed in XF1 can be 5A.

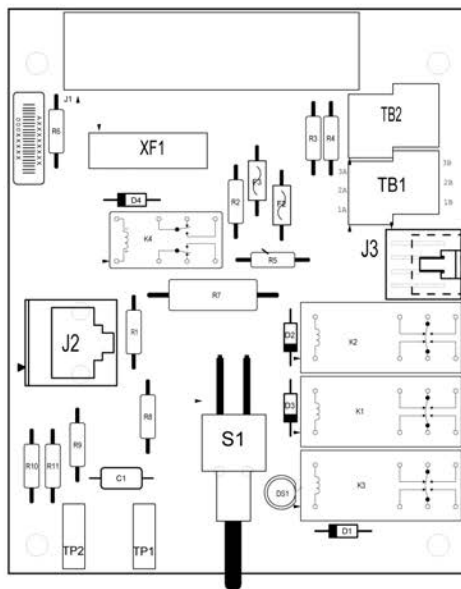
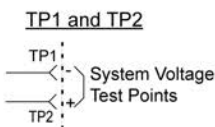

- TB1-1/A/1B: RS485 Southbound Output
- TB1-2A/2B: RS485 Northbound Output
- TB1-3A/3B: -48V Fused Output that can be used to power external devices
- TB2-1A: External -48V Fuse Alarm Input
- TB2-2A: External -58V Fuse Alarm Input
- TB2-3A: GMT Fuse Alarm Input
- TB2-1B/2B/3B: RS232 Output

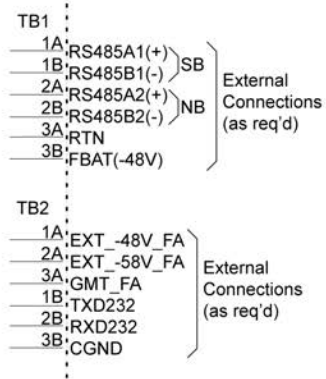

TB2 on System Interface Board
 Wire Size Capacity: 16 AWG to 26 AWG
 Recommended Torque: 2.0 in-lbs.

S1: Manual Battery Disconnect (MBD) switch and DS1 illuminates to indicate you're in the MBD mode, which means your Battery LVD is open and your Batteries are disconnected from the system.

IB2 (Controller Interface Board) and Optional EIB (Controller Extended Interface Board) Circuit Cards

The IB2 (Controller Interface Board) and Optional EIB (Controller Extended Interface Board) contain customer connection terminal blocks and a switch. Refer to the System Installation Manual IM582127000900 for details. Refer to Figure 4.1 for IB2 and EIB circuit card locations. Refer to Figure 4.5 and Figure 4.6 for circuit card illustrations.

Figure 4.5 IB2 (Controller Interface Board) Circuit Card

The relay assigned to "Critical Summary" alarm (relay 1 by default) will operate in the "Fail Safe Mode". "Fail Safe Mode" means Relay 1 is de-energized during an alarm condition, opening the contacts between the C and NO terminals, and closing the contacts between the C and NC terminals. The remaining seven (7) relays energize during an alarm condition, closing the contacts between the C and NO terminals, and opening the contacts between the C and NC terminals.

Not all I/O points may be available for customer connection (some may be used for factory system connections). The digital inputs and relay outputs may be preprogrammed for specific functions. Refer to the configuration drawing (C-drawing) supplied with your system for your system's specific configuration.

J3-J9:

Wire Size Capacity: 16 AWG to 26 AWG.

Wire Strip Length: 0.20 inch.

Recommended Torque: 2.2 in-lbs.

IB2 Assembly (with shield)

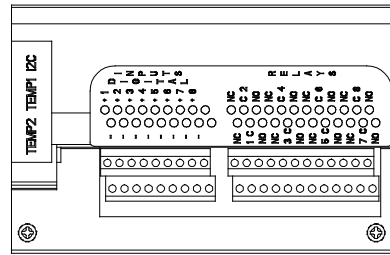

Switch settings must be in this position to interface with the controller.

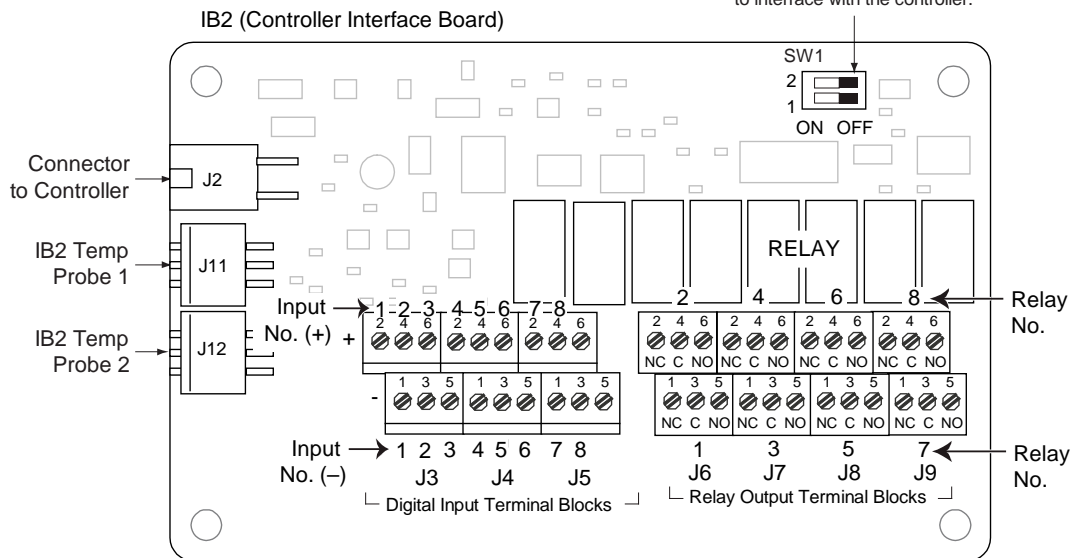

Schematic Diagram of IB2 (Controller Interface Board)

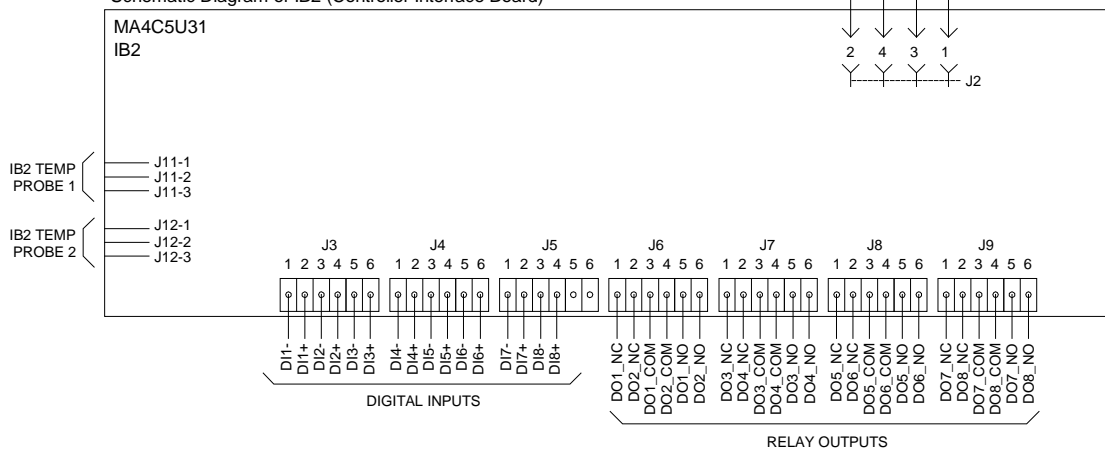
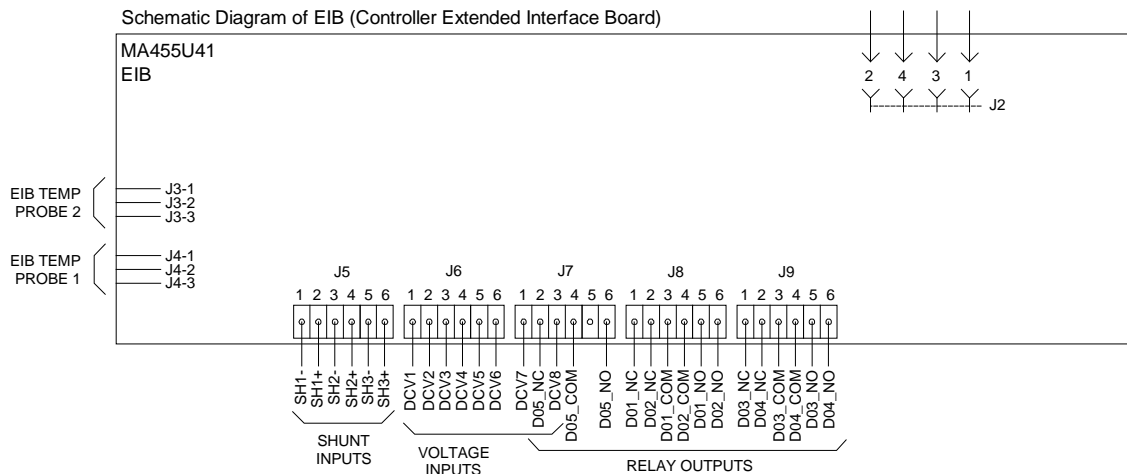
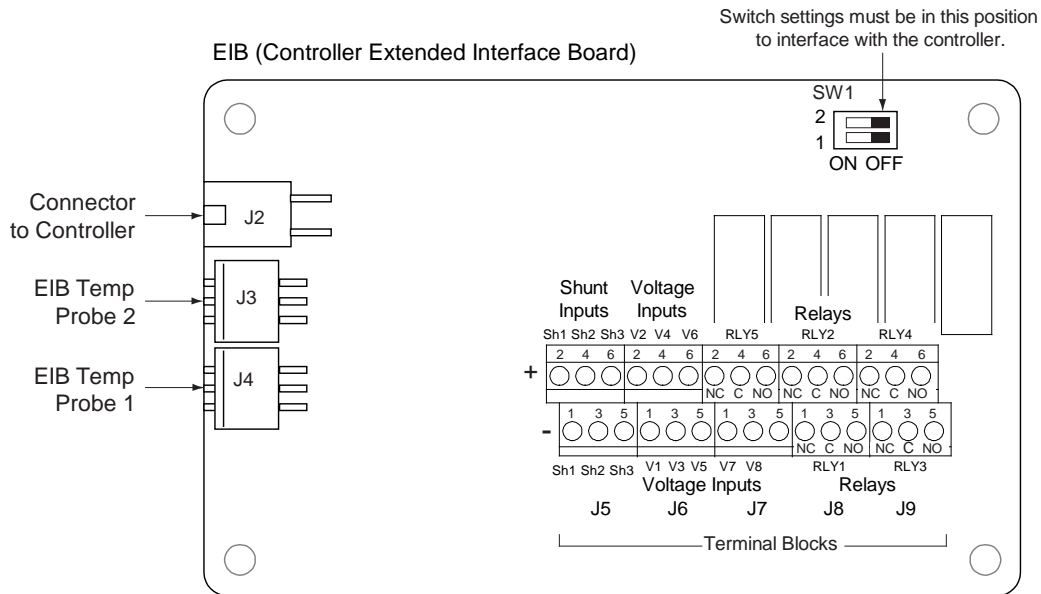
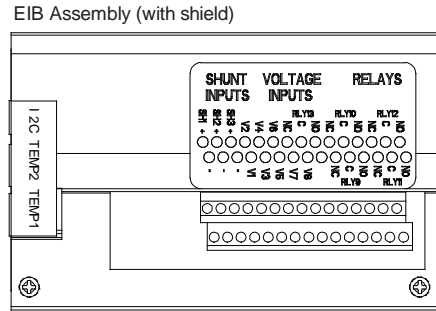

Figure 4.6 Optional EIB (Controller Extended Interface Board) Circuit Card

The five (5) relays energize during an alarm condition, closing the contacts between the C and NO terminals, and opening the contacts between the C and NC terminals.

Not all I/O points may be available for customer connection (some may be used for factory system connections). The relay outputs may be preprogrammed for specific functions. Refer to the configuration drawing (C-drawing) supplied with your system for your system's specific configuration.

- J5-J9:**
- Wire Size Capacity: 16 AWG to 26 AWG.
- Wire Strip Length: 0.20 inch.
- Recommended Torque: 2.2 in-lbs.



IB5 (Controller Second Ethernet Port Board) Circuit Card

The IB5 circuit card contains a second Ethernet port. Refer to the System Installation Manual IM582127000900 for details. Refer to Figure 4.1 for circuit card location and a circuit card illustration.

5 Maintenance

5.1 Important Safety Instructions



DANGER! Adhere to the “Important Safety Instructions” starting on page v.

5.2 System Maintenance Procedures

It is recommended to perform the maintenance procedures listed in Table 5.1 every 6-months to ensure continual system operation.

Table 5.1 Maintenance Procedures to be Performed at 6-Month Intervals

Procedure	Referenced In
Check ventilation openings for obstructions such as dust, papers, manuals, etc.	--
Inspect and tighten all installer's connections.	IM582127000900, “Making Electrical Connections” section.

5.3 Adding a Rectifier Module to an Empty Module Mounting Position

To increase system current capacity, a rectifier module can easily be added to a module mounting assembly that contains an empty rectifier module mounting position.

Refer to Rectifier Instructions UM1R483500E3 for a rectifier installation procedure.



NOTE! It is recommended that the current limit point be checked whenever a rectifier module is added to or removed from the power system. Refer to “Checking the Controller’s Current Limit Point after Adding or Removing a Rectifier/Converter Module” on page 15.



NOTE! The rectifier module being added is assigned by the controller the lowest available identification number. If desired, you can change the identification number. Refer to the NCU Instructions (UM1M830BNA) for a procedure.

5.4 Adding a Converter Module to an Empty Module Mounting Position

A converter module can easily be added to a module mounting assembly that contains an empty converter module mounting position.

Refer to Converter Instructions UM1C48583750P4 and/or UM1C48582000P3 for a converter installation procedure.

5.5 Installing Optional EIB (Controller Extended Interface Board)

Refer to the procedure in the Installation Manual (IM582127000900).

5.6 Reconfiguring Dual Voltage Panel (Lists 930, 931)

Dual voltage distribution panels in List 930 or List 931 can be reconfigured. Each 30-position distribution panel provides a combination of -48 VDC and -58 VDC positions. The five (5) right-most positions in each panel are dedicated to -48 VDC, and the five (5) left-most positions in each panel are dedicated to -58 VDC. Linking busbars and position labels can be arranged to configure each panel as needed. Jumpers are re-positioned for the discrete breaker/fuse alarms. A divider insulates between the two sections of the panel. Refer to Figure 5.1, Figure 5.3, and Figure 5.2 for details.

Procedure

1. Loosen but do not remove screws securing the panel cover to the plastic panel.
2. Remove the divider insulator by gently pulling forward near the top. Refer to Figure 5.1. Folded insulator is press-fit into the plastic panel slot.

Figure 5.1: Divider Insulator, Panel Cover, and Link Busbar

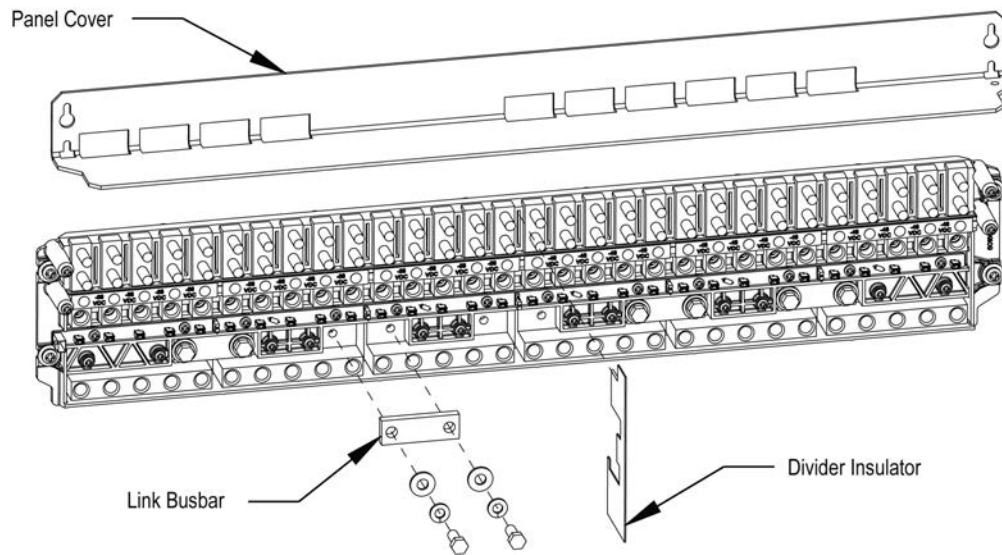

Busbar Link Hardware
 1/4-20 x 5/8" Long Hex Head Cap Screw
 1/4 Lock Washer
 1/4 Flat Washer

3. Move the 3-position alarm jumper at the original divider location from OFF-position (Down) to ON-position (Up). Refer to Figure 5.2 for example.

Figure 5.2: 3-Position Alarm Jumpers

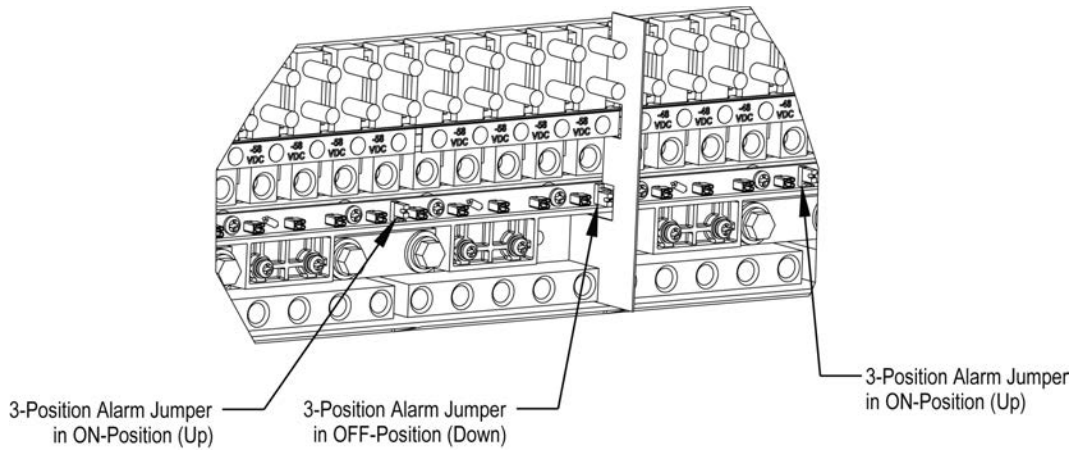

4. Remove link busbar hardware and link busbar from the position where the panel division is desired and move it to the original divider location.. Refer to Figure 5.1. Re-assemble link busbar hardware. Apply torque of 60 in-lbs.
5. Move 3-position alarm jumper at the new divider location from ON-position (Up) to OFF-position (Down). Refer to Figure 5.2.
6. Remove pushpins and indicator label(s) as required. All labels to the left of the divider location should be labeled as -58 VDC, and all labels to the right of the divider should be labeled as -48 VDC. Refer to Figure 5.3. Flip indicator label(s) to show opposite side (voltage). Re-install indicator label(s) and pushpins as required.

Figure 5.3: Dual Voltage Panel Reconfiguration

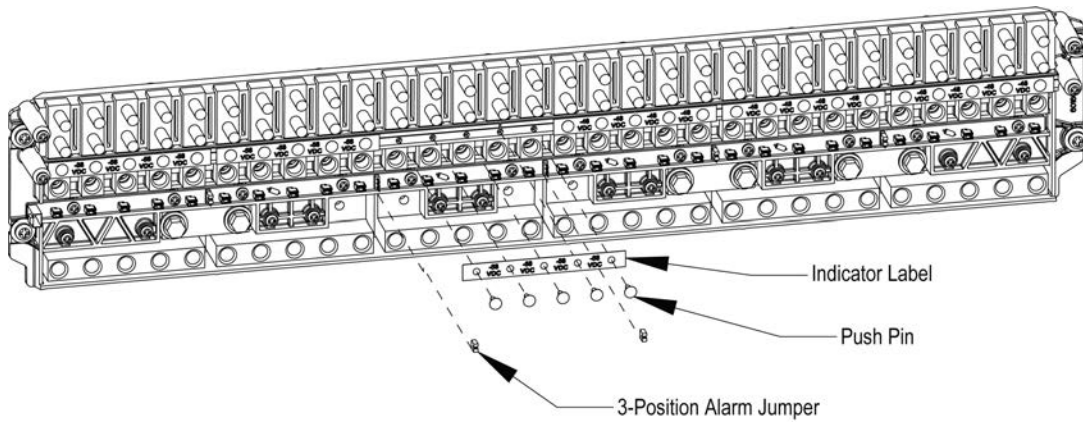

7. Re-install divider insulator at new location.
8. Re-install panel cover and tighten screws.

6 Troubleshooting and Repair

6.1 Important Safety Instructions



DANGER! Adhere to the “Important Safety Instructions” starting on page v.

6.2 Contact Information

Refer to Section 4.154 (provided with your customer documentation) for support contact information.

6.3 Controller and Rectifiers/Converters

For troubleshooting and repair instructions on these units, refer to the following documents.

- NCU Controller Instructions (UM1M830BNA)
- Rectifier Instructions (UM1R483500e3)
- Converter Instructions (UM1C48583750P4 and UM1C48582000P3)

6.4 Controller Configuration

If any controller configuration settings were changed, refer to the NCU Controller Instructions (UM1M830BNA) and save a copy of the configuration file. This file can be used to restore the controller settings, if required, at a later date.



NOTE! Provided on a USB drive furnished with the system is a controller configuration drawing (C-drawing) and the controller configuration files loaded into the controller as shipped.

6.5 System Troubleshooting Information

This system is designed for ease in troubleshooting and repair. The various indicators as described in “Local Controls and Indicators” on page 5 and in the controller and rectifier instructions are designed to isolate failure to a specific element. Once the faulty element has been identified, refer to “Replacement Information” on page 16 and “Replacement Procedures” on page 16.

Troubleshooting Alarm Conditions on the Controller

The controller displays alarm conditions as listed in the “Resolving Alarms” section of the controller’s User Manual. Programmable external alarm relays are also available. Refer to the System Installation Instructions (IM582127000900) and the configuration drawing (C-drawing) supplied with your power system documentation for your alarm relay configurations.

The controller’s *Active Alarm* and *Alarm History* submenus allow the User to view alarm details. Refer to the NCU Controller Instructions (UM1M830BNA) to access these menus.

Checking the Controller’s Current Limit Point after Adding or Removing a Rectifier/Converter Module

If a rectifier/converter is added; the respective current limit point in amps will automatically increase to maintain the same percentage. For example, if the current limit was set to 100% of combined capacity and a rectifier/converter is added, the new current limit set point will be 100% of the combined capacity including the new rectifier/converter.

If a rectifier/converter module is removed from the system (and the Rect Comm Fail alarm is cleared), the current limit point will remain unchanged unless the capacity of the remaining rectifiers/converters is not sufficient to maintain the present current limit point. If that happens, the current limit point will automatically increase to the maximum (121% of the remaining rectifiers/converters).

It is recommended that the current limit point be checked whenever a rectifier/converter module is added to or removed from the power system.

When setting total rectifier/converter current limit, the set point to each rectifier/converter is the total set point divided by the number of rectifiers/converters. For example, if the system contains five rectifiers/converters and the current limit is set to 150 amps then each rectifier/converter has a current limit set point of 30 amps. If one or more rectifiers/converters are removed or fail it will take several seconds for the individual set points to the remaining rectifiers/converters to be reset. In the example given, if one rectifier/converter is removed the current limit set point will drop to 120 amps (30 amps times four remaining rectifiers/converters) until the controller can send updated set points to the remaining rectifiers/converters. This takes a couple communication cycles (several seconds) after which each rectifier/converter would have a new set point of 37.5 amps for a total of 150 amps. The total current limit of the rectifiers/converters should not be set such that the loss of the redundant rectifiers/converters will cause this temporary set point to drop below the actual maximum expected load. If batteries are used on the rectifier/converter output, the batteries should support the load until the current limit set points can be re-established due to loss of a rectifier/converter.

Refer to the NCU Controller Instructions (UM1M830BNA) for a procedure.

Clearing a Rectifier/Converter Communications Fail Alarm after Removing a Rectifier/Converter

If a rectifier/converter module is removed from the system, a rectifier/converter communications failure alarm is generated. If the rectifier/converter module will not be replaced, the alarm should be cleared.

Refer to the NCU Controller Instructions (UM1M830BNA) for a procedure.

Clearing a Rectifier/Converter Lost Alarm

If the controller resets while a rectifier/converter communications fail alarm is active, the rectifier/converter communications fail alarm is replaced with a rectifier/converter lost alarm.

Refer to the NCU Controller Instructions (UM1M830BNA) for a procedure to clear the alarm.

6.6 Replacement Information

Replacement Assemblies

When a trouble symptom is localized to a faulty rectifier module, converter module, controller, or system circuit card; that particular device or circuit card should be replaced in its entirety. No attempt should be made to troubleshoot or repair individual components on any rectifier module, controller, or circuit card.

Refer to SAG582127000 (System Application Guide) for replacement part numbers.

6.7 Replacement Procedures

6.7.1 Replacing a Rectifier or Converter Module

Refer to the Rectifier Instructions (UM1R483500e3) for a rectifier module replacement procedure. Refer to the Converter Instructions (UM1C48583750P4 or UM1C48582000P3) for a converter replacement procedure. Refer also to “System Troubleshooting Information” on page 15.



NOTE! *The rectifier or converter module being replaced is assigned by the controller the lowest available identification number. If desired, you can change the identification number. Refer to the NCU Instructions (UM1M830BNA) for a procedure.*

6.7.2 Replacing the NCU Controller

Refer to the NCU Controller Instructions (UM1M830BNA) for a controller replacement procedure.

6.7.3 Replacing a Distribution Device

General

Replace distribution devices with the same type and rating. Refer to System Application Guide SAG582127000 for part numbers.

Distribution Fuse “Alarm Fuse” Replacement

If a distribution fuse opens, the associated alarm fuse opens. Replace the distribution fuse before replacing the alarm fuse.

Procedure

1. An alarm fuse is removed by pulling it straight out of the fuseholder. If the alarm fuse is located in a modular fuse carrier, hold the fuse carrier in place with your thumb while pulling on the alarm fuse to prevent the entire carrier from inadvertently being pulled out.
2. Safety fuse covers are provided for all Bussmann GMT type fuses installed in the system. These covers snap onto the fuses and provide protection from exposed electrical terminations when a fuse opens. Ensure that the safety fuse cover is installed after replacing a fuse. Refer to Figure 6.1 for installation details.

Figure 6.1 Installation of Safety Fuse Covers

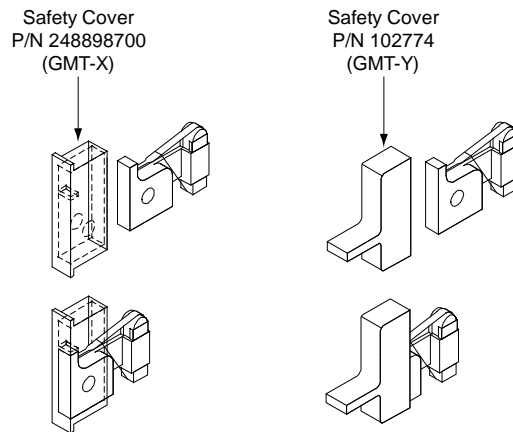

Replacing a TPS/TLS Fuse

Procedure



NOTE! Refer to Figure 6.2 as this procedure is performed.

1. Open the distribution cabinet's front door.
2. Remove the fuse carrier from the mounted fuseholder body by pulling it straight out. Hold the fuseholder body while you pull the fuse carrier from the body.
3. Remove the open fuse from the fuse carrier and replace it with the same type and rating.
4. Replace the alarm fuse located in the front of the fuse carrier with the same type and rating. Ensure that a plastic safety cover is installed on the alarm fuse.
5. Push the fuse carrier securely back into the mounted fuseholder body. Note that a polarizing key on the bottom of the carrier prevents the carrier from being inserted upside down.
6. Verify no Fuse Alarms are active.
7. Close the distribution cabinet's front door.

Replacing a Bullet Nose Fuseholder

Procedure



NOTE! Refer to Figure 6.2 as this procedure is performed.

1. Open the distribution cabinet's front door.
2. Remove the fuse carrier from the mounted fuseholder body by pulling it straight out. Hold the fuseholder body while you pull the fuse carrier from the body.
3. Gently rock the defective fuseholder up and down while pulling firmly outward until the fuseholder is free from the distribution panel.
4. Orient the replacement fuseholder as shown in Figure 6.2. Insert the terminals on the rear of the fuseholder into their corresponding sockets on the distribution panel. Ensure the alarm contact on the back of the fuseholder makes contact with the alarm terminal on the spring strip. Push fuseholder in firmly until fully seated in the distribution panel.
5. Push the fuse carrier securely back into the mounted fuseholder body. Note that a polarizing key on the bottom of the carrier prevents the carrier from being inserted upside down.
6. Verify no Fuse Alarms are active.
7. Close the distribution cabinet's front door.

Figure 6.2 Replacing a TPS/TLS Fuseholder and/or Fuse

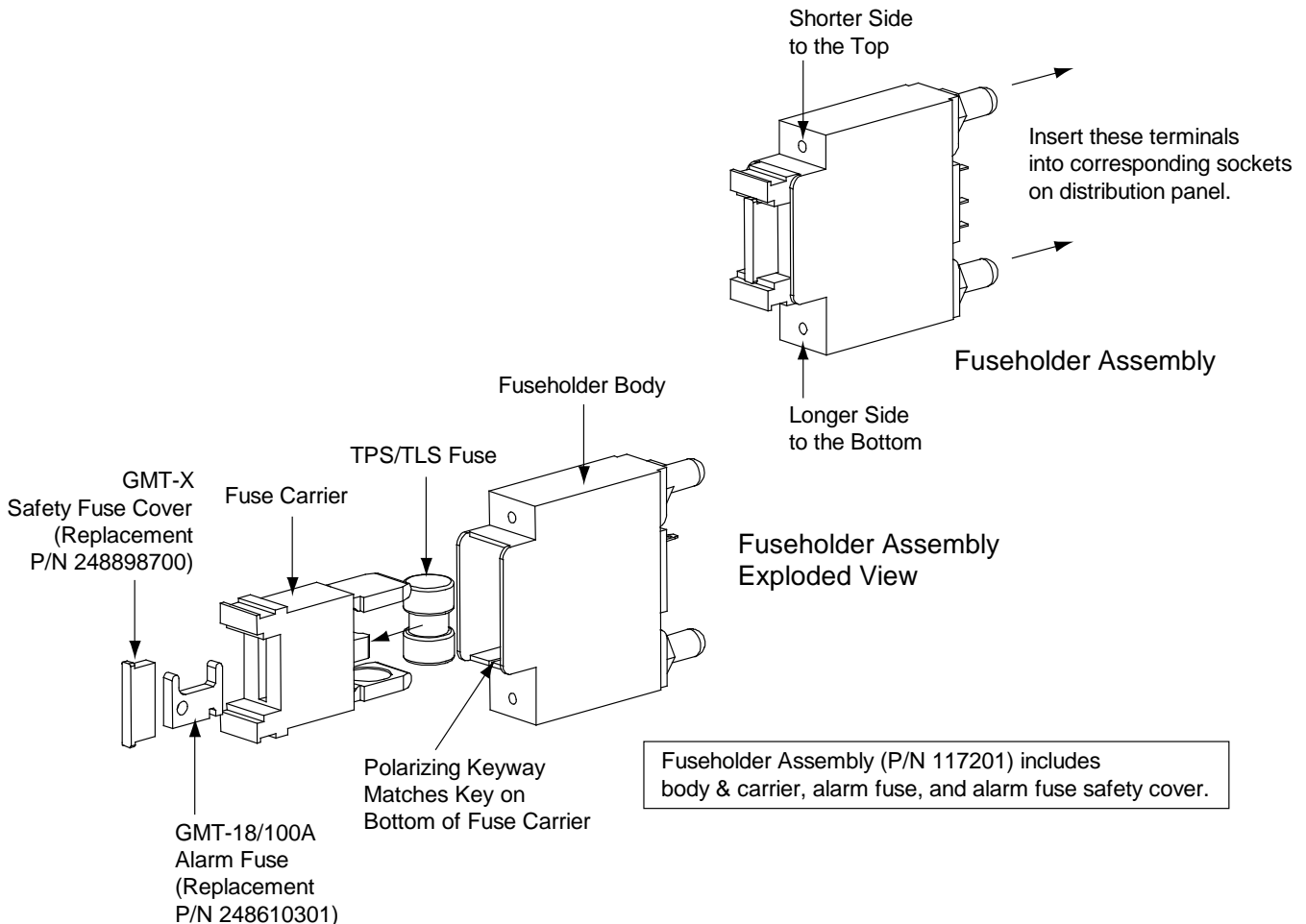

Replacing a Bullet Nose Circuit Breaker

Procedure



NOTE! Refer to Figure 6.3 as this procedure is performed.

1. Open the distribution cabinet's front door.
2. Operate the defective circuit breaker to the OFF position.
3. Gently rock the defective circuit breaker up and down while pulling firmly outward until the breaker is free from the distribution panel.
4. Ensure that the circuit breaker is in the OFF position, and is of the correct rating.
5. Orient the replacement circuit breaker as shown in Figure 6.3. Insert the terminals on the rear of the circuit breaker into their corresponding sockets on the distribution panel. Ensure the alarm contact on the back of the circuit breaker makes contact with the alarm terminal on the spring strip. Push distribution device in firmly until fully seated in the distribution panel.
6. Operate the replacement circuit breaker to the ON position.
7. Verify no Circuit Breaker Alarms are active.
8. Close the distribution cabinet's front door.

Figure 6.3 Replacing a Bullet Nose Circuit Breaker

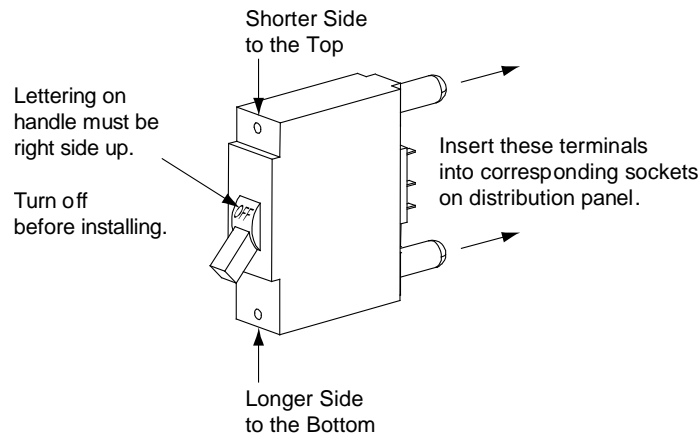

6.7.4 Circuit Card Replacement Procedures



WARNING! Circuit cards used in this system contain static-sensitive devices. Refer to Section 4-154 (provided with your customer documentation) for static-sensitive device precautions.

General

The following circuit card replacement procedures can be performed with the system operating.

Circuit Card Locations

Refer to Figure 4.1 (Lists 600, 601, 900, 901) on page 6 or Figure 4.2 (Lists 930, 931) on page 7 for circuit card locations.

Replacing the System Interface Circuit Card

Procedure

1. Performing this procedure may activate external alarms. Do one of the following. If possible, disable these alarms. If these alarms cannot be easily disabled, notify the appropriate personnel to disregard any future alarms associated with this system while the procedure is being performed.



DANGER! Performing the next steps exposes service personnel to battery potential. Exercise extreme caution not to inadvertently contact or have any tool inadvertently contact any energized electrical termination.



WARNING! Damage to the circuit card may result if the next step is not followed.

2. Connect an approved grounding strap to your wrist. Attach the other end to a suitable ground.
3. Carefully label any wires connected to the customer connection terminal block on the circuit card. These wires must be connected to the same terminals on the replacement circuit card. Refer to Figure 4.3 (Lists 600, 601, 900, 901) on page 8 or Figure 4.4 (Lists 930, 931) on page 9.
4. Carefully label the connectors plugged into the circuit card. These connectors must be plugged into the same connectors on the replacement circuit card. Refer to Figure 4.3 (Lists 600, 601, 900, 901) on page 8 or Figure 4.4 (Lists 930, 931) on page 9.
5. Remove the external wiring from the customer connection terminal block. DO NOT allow the bare wire end to contact any grounded or energized object. Isolate the wire end with electrical tape. Repeat for each wire to be removed.
6. Unplug all connectors plugged into the circuit card.
7. Remove the screws securing the circuit card and remove the circuit card from the distribution cabinet.
8. In this step, ensure you do not intermix the old and replacement circuit cards. Set the shorting jumper on the replacement circuit card to match the location on the old circuit card. Jumper settings are documented in the “Setting Jumper and Switch Options” section of the Power System Installation Instructions (IM582127000900).
9. Orient the replacement circuit card over its mounting position inside the distribution cabinet, and secure with the screws removed from the old circuit card.
10. Plug all connectors removed from the old circuit card into the same position on the replacement circuit card.
11. Reconnect the external wiring to the correct terminals on the customer connection terminal block. First remove the electrical tape that was applied to the bare wire end in a previous step. DO NOT allow the bare wire end to contact any grounded or energized object. After securing the wire, gently tug on the wire to ensure that it cannot be pulled out of the terminal block. Repeat for each wire to be reconnected.
12. Remove the grounding wrist strap.
13. Enable the external alarms or notify appropriate personnel that this procedure is finished.
14. Ensure that there are no local or remote alarms active on the system.

Replacing the IB2 (Controller Interface Board) or Optional EIB (Controller Extended Interface Board) Circuit Card

Procedure

1. Performing this procedure may activate external alarms. Do one of the following. If possible, disable these alarms. If these alarms cannot be easily disabled, notify the appropriate personnel to disregard any future alarms associated with this system while the procedure is being performed.



DANGER! Performing the next steps exposes service personnel to battery potential. Exercise extreme caution not to inadvertently contact or have any tool inadvertently contact any energized electrical termination.

2. Open the distribution cabinet's front door.



WARNING! Damage to the circuit card may result if the next step is not followed.

3. Connect an approved grounding strap to your wrist. Attach the other end to a suitable ground.
4. Carefully label the wires connected to the customer connection terminal blocks on the circuit card. These wires must be connected to the same terminals on the replacement circuit card. Refer to Figure 6.4 or Figure 6.5.
5. Carefully label the connectors plugged into the circuit card. These connectors must be plugged into the same connectors on the replacement circuit card. Refer to Figure 6.4 or Figure 6.5.



DANGER! In the next step, external alarm wiring may be energized from an external source. DO NOT allow bare wire ends to contact any grounded or energized object.

6. Remove the external wiring from the customer connection terminal blocks. DO NOT allow the bare wire end to contact any grounded or energized object. Isolate the wire end with electrical tape. Repeat for each wire to be removed.
7. Unplug all connectors plugged into the circuit card.
8. Remove the circuit card (and shield) from the distribution cabinet by removing the screws securing it to the cabinet. Refer to Figure 6.4 or Figure 6.5.
9. In this step, ensure you do not intermix the old and replacement circuit cards. Set the switch on the replacement circuit card to the same setting as the old circuit card. Switch settings are documented in the "Setting Jumper and Switch Options" section of the Power System Installation Instructions (IM582127000900).
10. Secure the replacement circuit card (and shield) to the distribution cabinet. Refer to Figure 6.4 or Figure 6.5.
11. Plug all connectors removed from the old circuit card into the same position on the replacement circuit card.



DANGER! In the next step, external alarm wiring may be energized from an external source. DO NOT allow bare wire ends to contact any grounded or energized object.

12. Reconnect the external wiring to the correct terminals on the customer connection terminal block. First remove the electrical tape that was applied to the bare wire end in a previous step. DO NOT allow the bare wire end to contact any grounded or energized object. After securing the wire, gently tug on the wire to ensure that it cannot be pulled out of the terminal block. Repeat for each wire to be reconnected.
13. Remove the grounding wrist strap.
14. Close the distribution cabinet's front door.

15. Reboot the controller.
 - Local Menu Navigation:** At the Main Screen, press ENT and ESC at the same time to reset the NCU Controller.
 - Web Menu Navigation:** Go to Advance Settings Menu / SW Maintenance Tab / Reboot Controller button.
16. Enable the external alarms or notify appropriate personnel that this procedure is finished.
17. Ensure that there are no local or remote alarms active on the system.

Figure 6.4 Replacing the IB2 (Controller Interface Board) Circuit Card

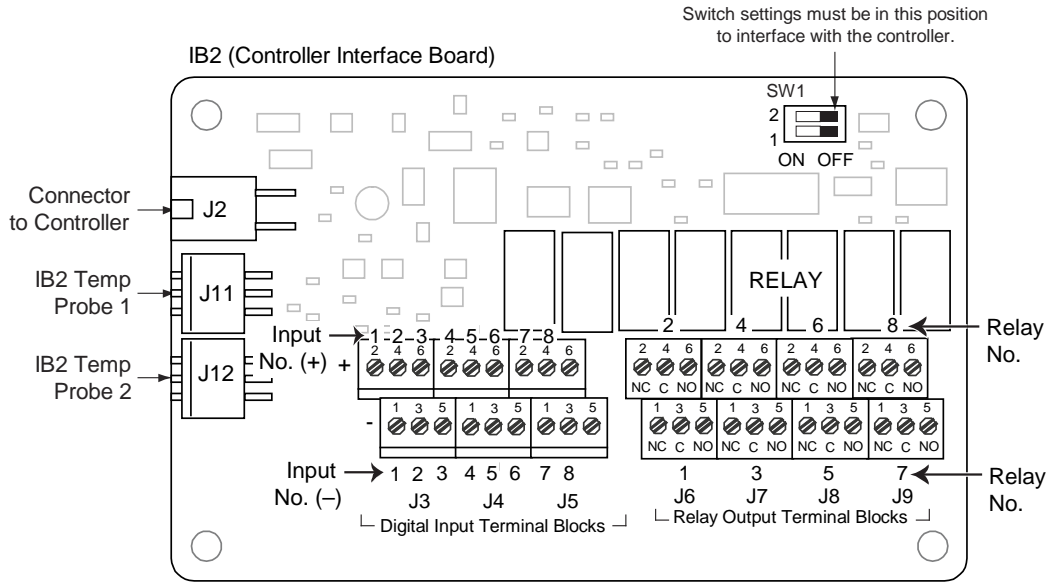

J3-J9:
 Wire Size Capacity: 16 AWG to 26 AWG.
 Wire Strip Length: 0.20 inch.
 Recommended Torque: 2.2 in-lbs.

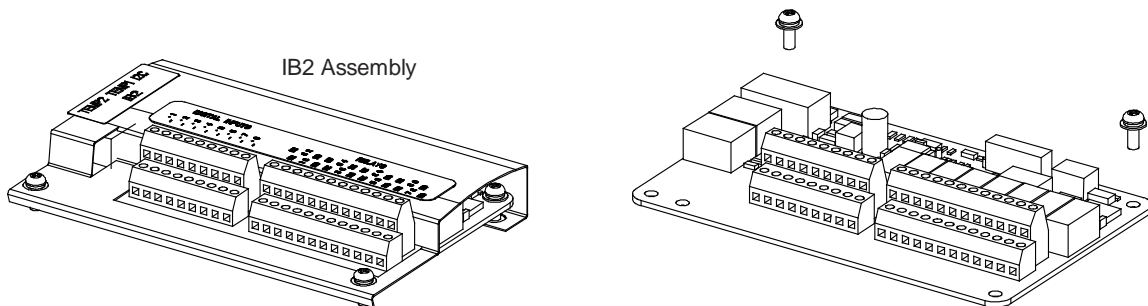
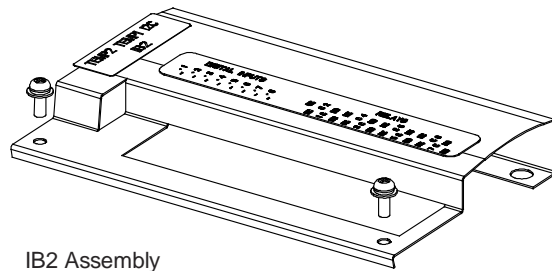
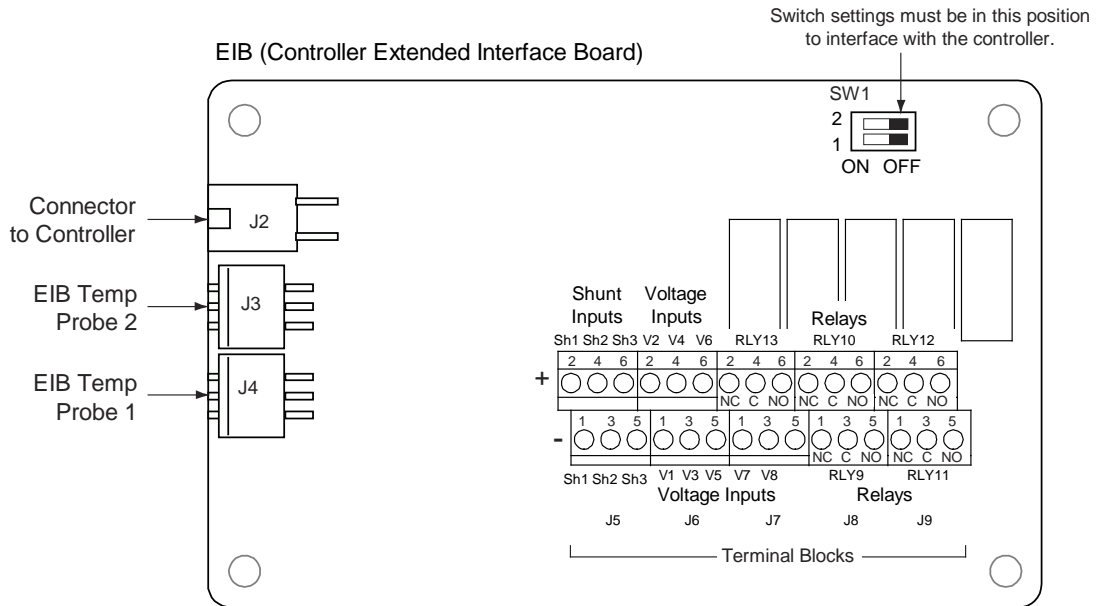

Figure 6.5 Replacing the EIB (Controller Extended Interface Board) Circuit Card



J5-J9

Wire Size Capacity: 16 AWG to 26 AWG.

Wire Strip Length: 0.20 inch.

Recommended Torque: 2.2 in-lbs.

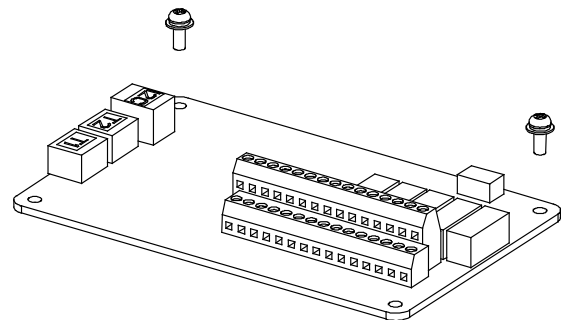
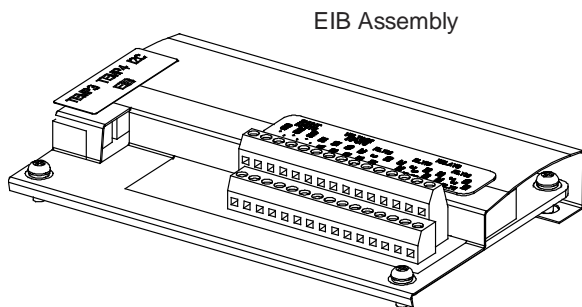
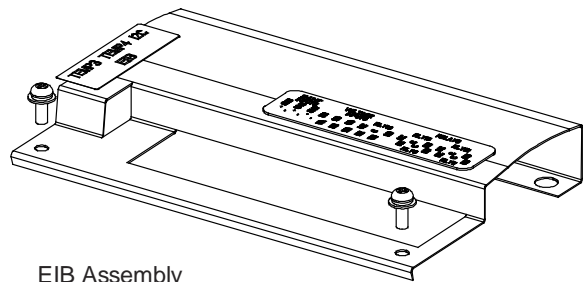

Replacing the IB5 (NCU Controller Second Ethernet Port Board) Circuit Card

Procedure

1. Performing this procedure may activate external alarms. Do one of the following. If possible, disable these alarms. If these alarms cannot be easily disabled, notify the appropriate personnel to disregard any future alarms associated with this system while the procedure is being performed.



DANGER! Performing the next steps exposes service personnel to battery potential. Exercise extreme caution not to inadvertently contact or have any tool inadvertently contact any energized electrical termination.

2. Open the distribution cabinet's front door.



WARNING! Damage to the circuit card may result if the next step is not followed.

3. Connect an approved grounding strap to your wrist. Attach the other end to a suitable ground.
4. Loosen the captive fastener securing the latch mechanism to the front of the NCU. Pull the latch mechanism away from the NCU (this will retract the latch mechanism located on the bottom of the NCU). This unlocks the NCU from the shelf. Slide the NCU partially out from the shelf.
5. Carefully label the connectors plugged into the circuit card. These connectors must be plugged into the same connectors on the replacement circuit card. Refer to Figure 6.6.
6. Unplug all connectors plugged into the circuit card.
7. Remove the circuit card (and shield) from the distribution cabinet by removing the screws securing it to the cabinet. Refer to Figure 6.6.
8. Secure the replacement circuit card (and shield) to the distribution cabinet. Refer to Figure 6.6.
9. Plug all connectors removed from the old circuit card into the same position on the replacement circuit card.
10. Slide the NCU completely into its mounting position. Push the latch mechanism into the front panel of the NCU, and secure by tightening the captive fastener. This locks the NCU securely to the shelf.
11. Remove the grounding wrist strap.
12. Close the distribution cabinet's front door.
13. To verify that the IB5 board is functioning, from the Main Menu on the local display, press the ESC button, then down arrow and verify the IP address 192.168.100.100 is displayed.
14. Enable the external alarms or notify appropriate personnel that this procedure is finished.
15. Ensure that there are no local or remote alarms active on the system.

Figure 6.6 Replacing the IB5 (NCU Controller Second Ethernet Port Board) Circuit Card

NOTE! List 900 is shown, but the replacement procedure for Lists 600, 601, 901, 930, and 931 is similar.

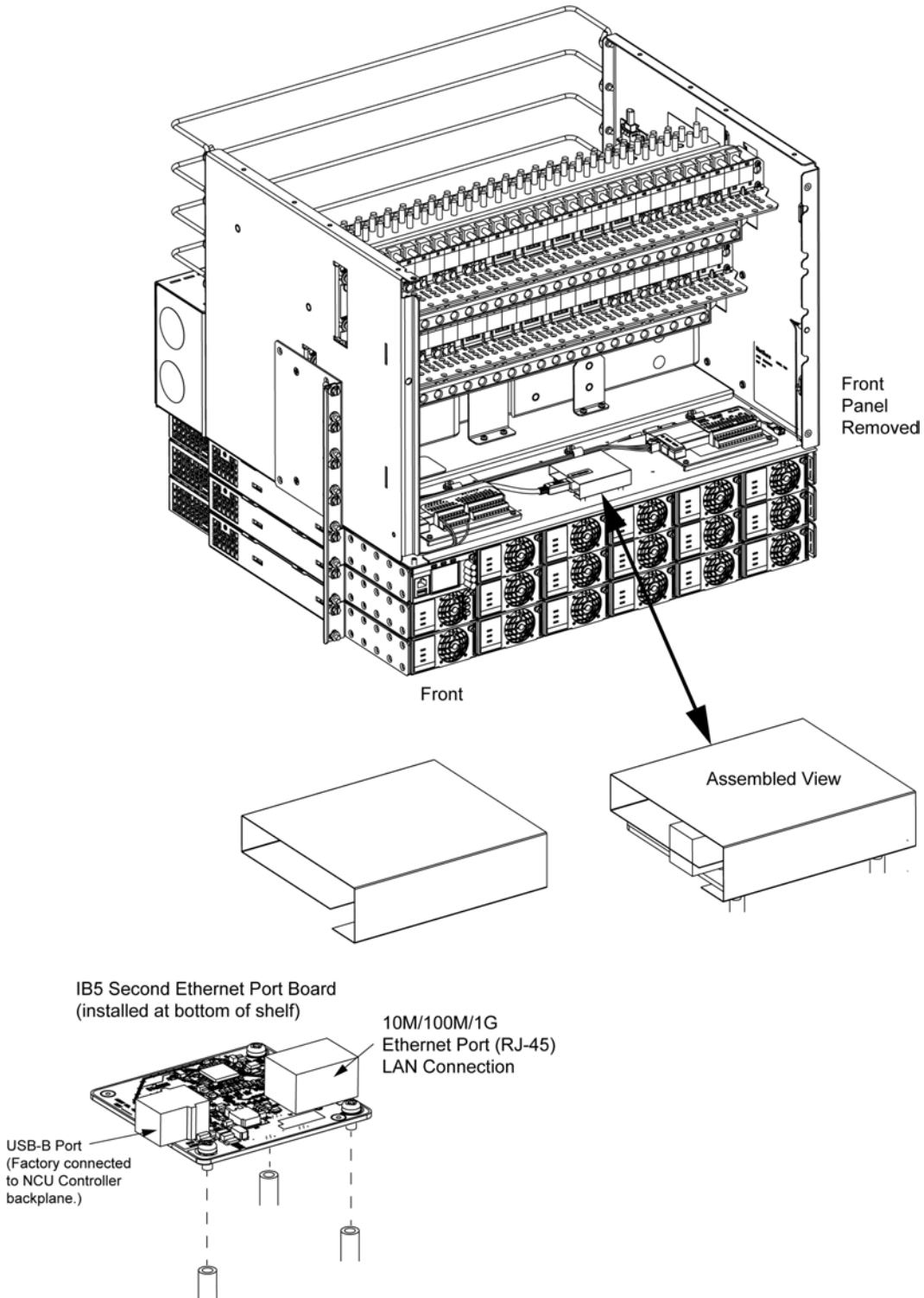

6.7.5 Replacing the Distribution Panel



DANGER! All sources of AC and DC power must be completely disconnected from this system before performing this procedure. Use a voltmeter to verify no DC voltage is present on the system busbars before proceeding.

Procedure



NOTE! Refer to Figure 6.7 (Lists 600, 601, 900, 901) or Figure 6.8 (Lists 930, 931) as this procedure is performed.

Removing the Distribution Panel

1. Performing this procedure will activate external alarms. Do one of the following. If possible, disable these alarms. If these alarms cannot be easily disabled, notify the appropriate personnel to disregard any future alarms associated with this system while the procedure is being performed.
2. Open the distribution cabinet's front door.
3. Remove the distribution panel cover.
4. Disconnect all system load wiring from the circuit breaker/fuse positions on the distribution panel.
5. Disconnect the alarm wiring from the distribution panel. See Figure 6.7 or Figure 6.8.
6. Remove the busbar hardware securing the system load distribution device busbars to the panel. See Figure 6.7 or Figure 6.8.
7. Remove the distribution panel hardware securing the distribution panel to the distribution cabinet. Remove the distribution panel from the distribution cabinet. See Figure 6.7 or Figure 6.8.

Installing the Distribution Panel



NOTE! In the following procedure, before making busbar-to-busbar connections, apply a thin coating of electrical anti-oxidizing compound to the mating surfaces of the busbars.

1. Orient the replacement distribution panel into distribution cabinet, checking to ensure no wires are pinched. Replace the distribution panel hardware securing the distribution panel to the distribution cabinet. Refer to Figure 6.7 or Figure 6.8 for hardware build-up and torque.
2. For Lists 930 and 931, ensure that the -48V / -58V split is the same as on as the old one.
3. Replace the busbar hardware securing the system load distribution device busbars to the distribution panel. Refer to Figure 6.7 or Figure 6.8 for hardware build-up and torque.
4. Reconnect the alarm wiring to the distribution panel. See Figure 6.7 or Figure 6.8.
5. Reconnect the load distribution wiring to the circuit breaker/fuse positions on the distribution panel.
6. Transfer the plug-in circuit breakers or fuses from the old distribution panel to the replacement distribution panel.
7. Replace the distribution panel cover.

Restarting the Power System

1. Reconnect the AC and DC power sources to the power system.
2. Start the power system. Refer to the separate Installation Instructions (IM582127000900) for a startup procedure.
3. Close the distribution cabinet's front door.
4. Verify no alarms are active.

Figure 6.7: Replacing a Distribution Panel (Lists 600, 601, 900, 901)

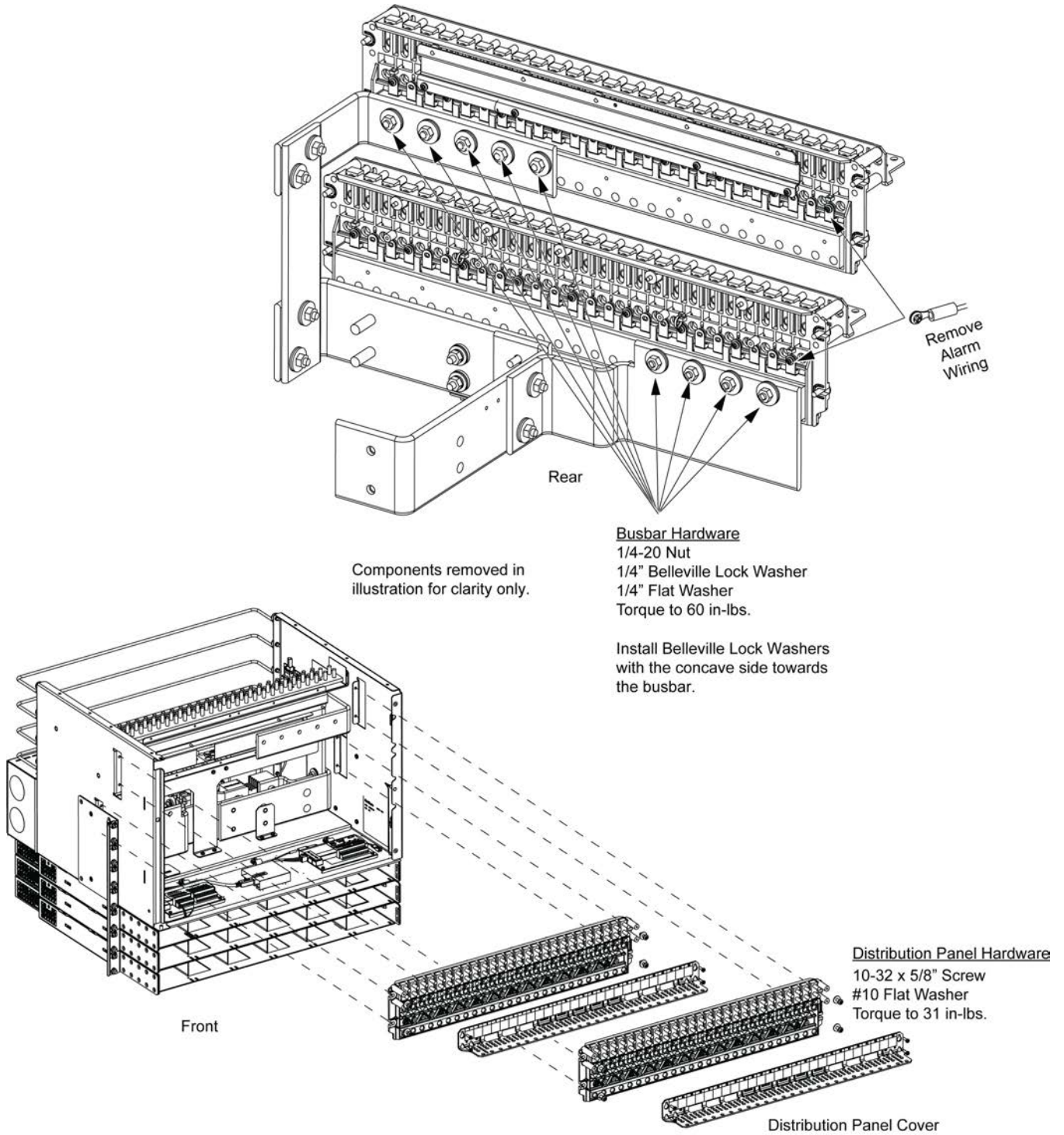
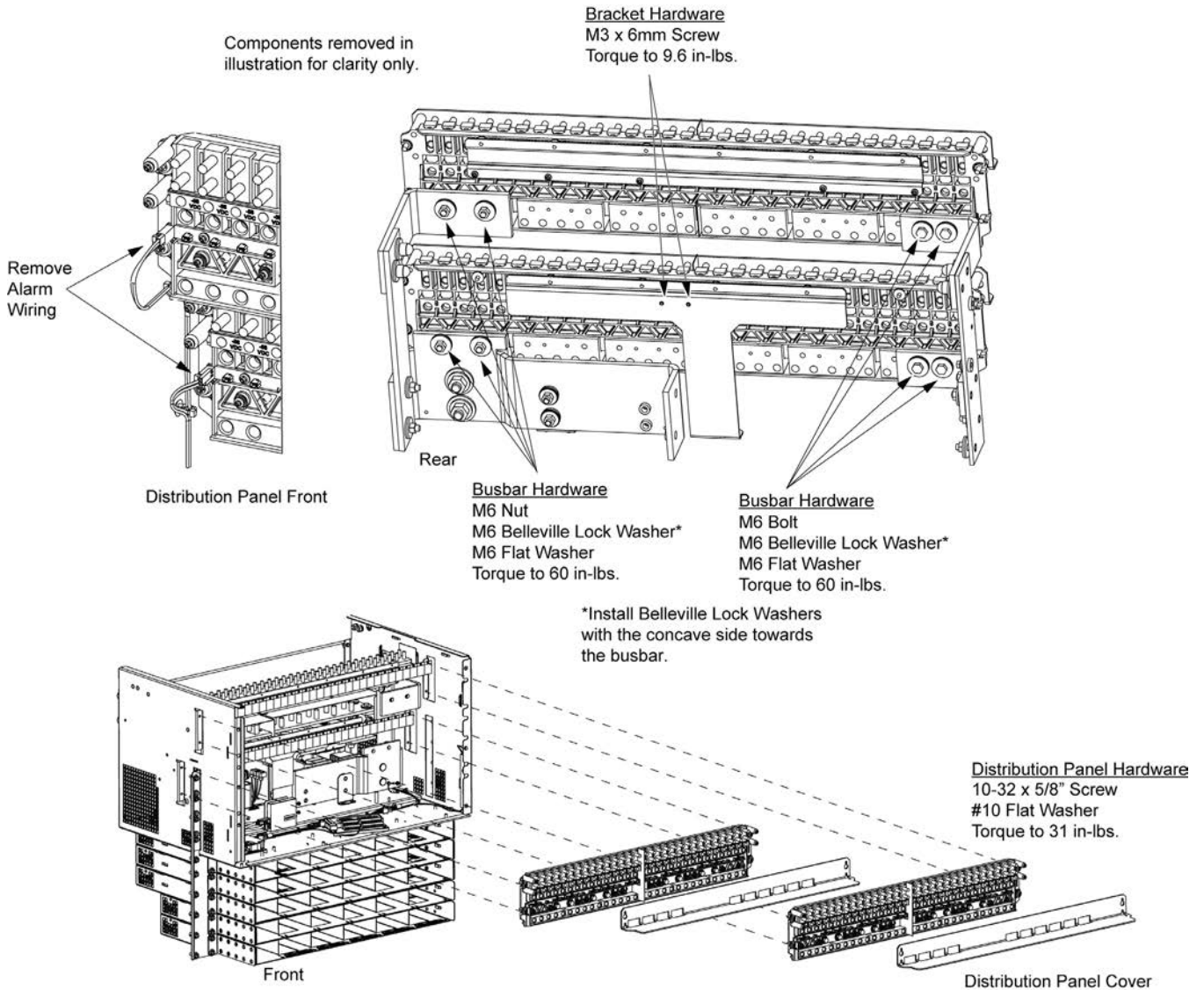

Figure 6.8: Replacing a Distribution Panel (Lists 930, 931)



6.7.1 Replacing a Battery Disconnect Contactor (if furnished)



DANGER! All sources of AC and DC power must be completely disconnected from this power system before performing this procedure. Use a voltmeter to verify no DC voltage is present on the system busbars before proceeding.

Procedure



NOTE! Refer to Figure 6.9 (Lists 600, 601, 900, 901), Figure 6.10 (Lists 930, 931), and Figure 6.11 as this procedure is performed.

Removing the Contactor

1. Verify all AC and DC power sources are disconnected from the power system.
2. Remove the battery busbar assembly. See Figure 6.9 or Figure 6.10.
3. Remove the shield below the battery busbar assembly. See Figure 6.9 or Figure 6.10.
4. Disconnect the wiring to the contactor by unplugging the quick disconnects.
5. Note the orientation of the contactor to ensure the replacement is installed the same way. Unbolt the contactor (4-places) and remove.

Installing the Replacement Contactor

1. Position the replacement contactor oriented the same way as the old.
2. Secure the contactor with the hardware removed above. Refer to Figure 6.9 or Figure 6.10 for hardware build-up and recommended torque.
3. Replace the wiring to the contactor by plugging-in the quick disconnects. Refer to Figure 6.11.
4. Replace the shield below the battery busbar assembly. See Figure 6.9 or Figure 6.10.
5. Replace the battery busbar assembly. See Figure 6.9 or Figure 6.10 for hardware build-up and recommended torque.

Restarting the Power System

1. Reconnect the AC and DC power sources to the power system.
2. Start the power system. Refer to the separate Installation Instructions (IM582127000900) for a startup procedure.
3. Verify no alarms are active.

Figure 6.9: Replacing a Battery Disconnect Contactor (Lists 600, 601, 900, 901)

Components removed in illustration for clarity only.

Apply electrical anti-oxidizing compound to busbar mating surfaces.

Install Belleville Lock Washers with the concave side towards the busbar.

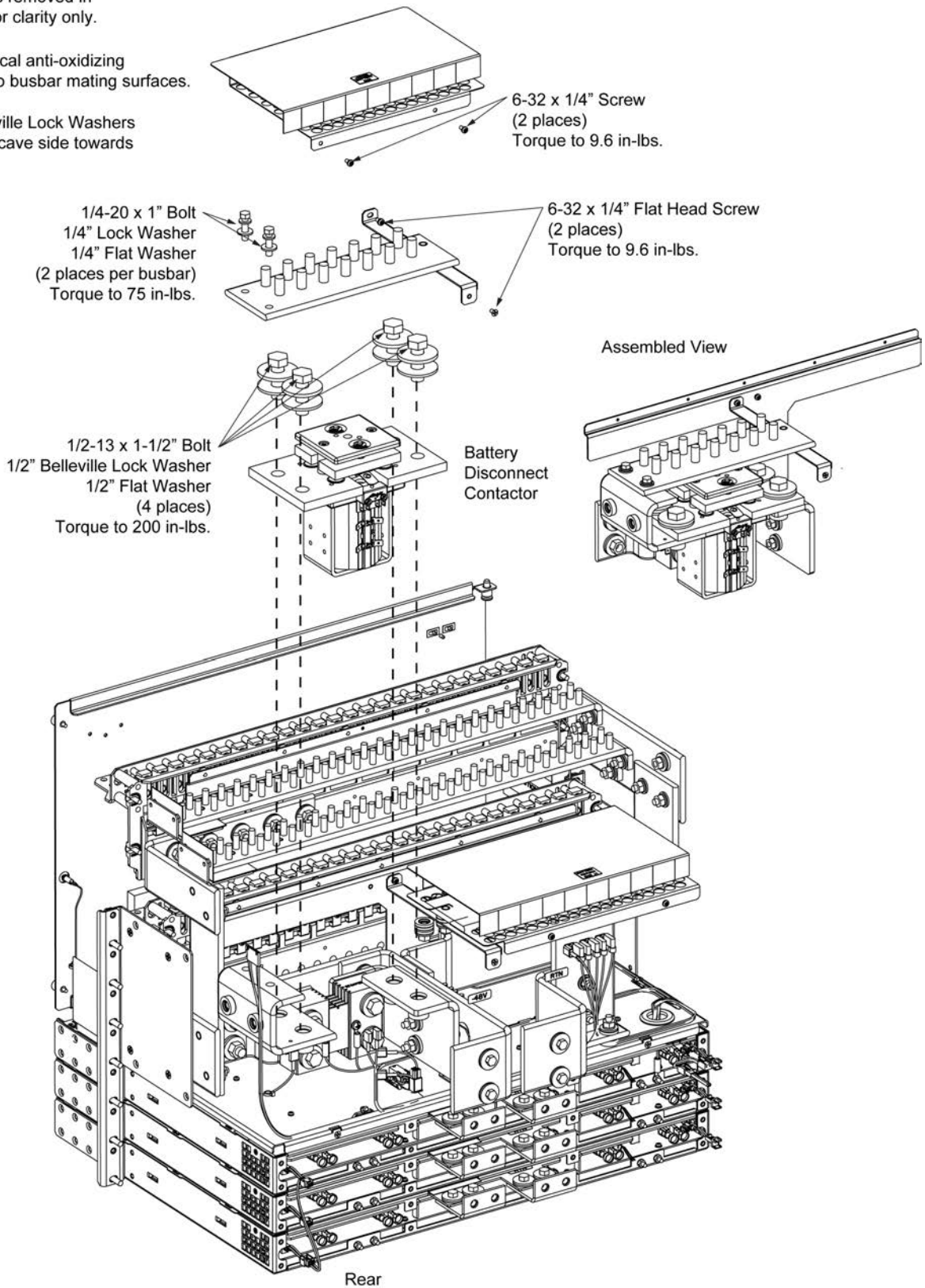

Figure 6.10: Replacing a Battery Disconnect Contactor (Lists 930, 931)

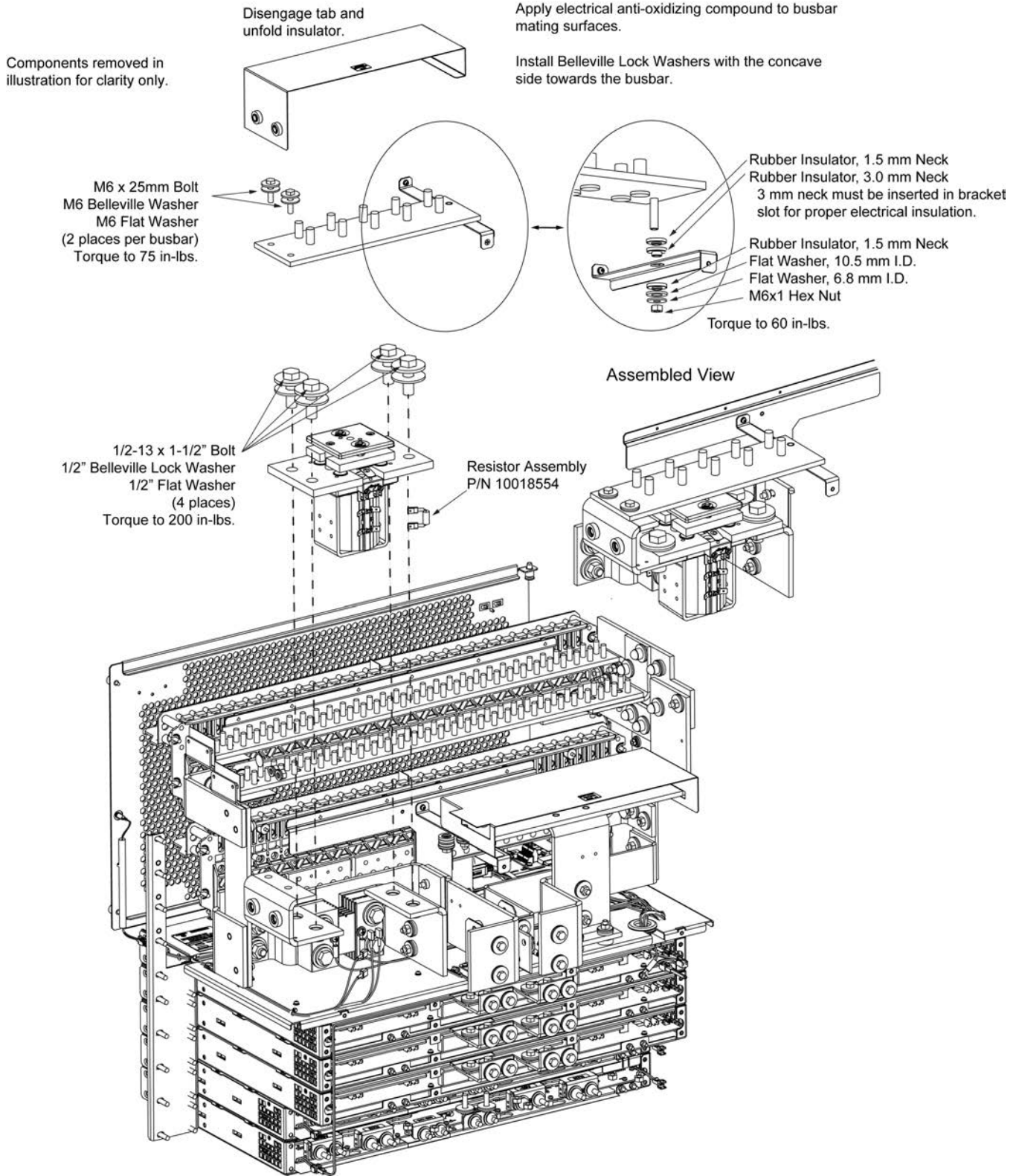
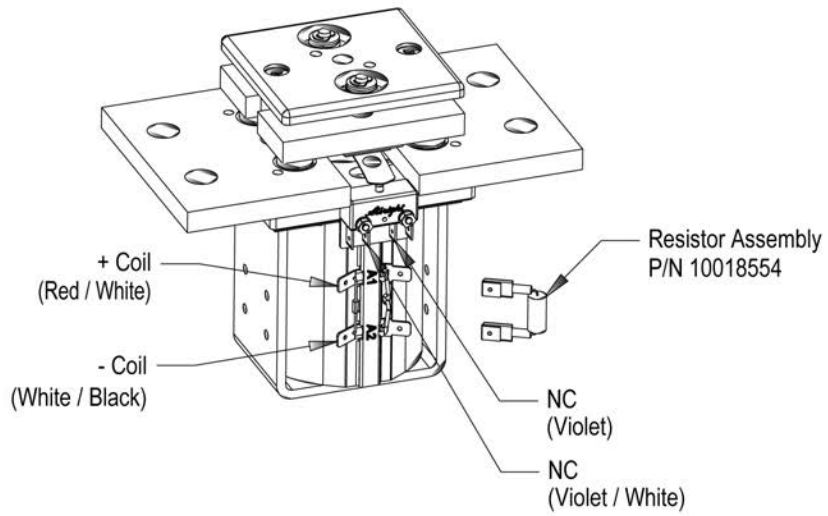

Figure 6.11: Battery Contactor Wiring

Note: Refer to wiring diagram T582127000930.

Manufacturer (Option): Albright



Manufacturer (Option): Contact Industries

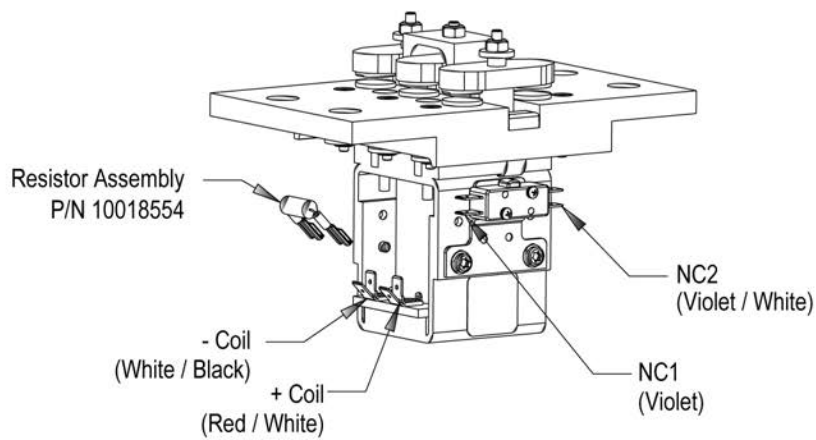

Connect with Vertiv on Social Media



<https://www.facebook.com/vertiv/>



<https://www.instagram.com/vertiv/>



<https://www.linkedin.com/company/vertiv/>



<https://www.x.com/vertiv/>



Vertiv.com | Vertiv Headquarters, 505 N Cleveland Ave, Westerville, OH 43082, USA

© 2026 Vertiv Group Corp. All rights reserved. Vertiv™ and the Vertiv logo are trademarks or registered trademarks of Vertiv Group Corp. All other names and logos referred to are trade names, trademarks or registered trademarks of their respective owners. While every precaution has been taken to ensure accuracy and completeness here, Vertiv Group Corp. assumes no responsibility, and disclaims all liability, for damages resulting from use of this information or for any errors or omissions.