



NetSure™ 7100 Series -48 VDC Power System

User Manual

Specification Number: 582127000100, 582127000101, 582127000102, 582127000103, 582127000203, 582127000500,
582127000501, 582127000502, 582127000503

Model Number: 7100

The information contained in this document is subject to change without notice and may not be suitable for all applications. While every precaution has been taken to ensure the accuracy and completeness of this document, Vertiv assumes no responsibility and disclaims all liability for damages resulting from use of this information or for any errors or omissions. Refer to other local practices or building codes as applicable for the correct methods, tools, and materials to be used in performing procedures not specifically described in this document.

The products covered by this instruction manual are manufactured and/or sold by Vertiv. This document is the property of Vertiv and contains confidential and proprietary information owned by Vertiv. Any copying, use or disclosure of it without the written permission of Vertiv is strictly prohibited.

Names of companies and products are trademarks or registered trademarks of the respective companies. Any questions regarding usage of trademark names should be directed to the original manufacturer.

Technical Support Site

If you encounter any installation or operational issues with your product, check the pertinent section of this manual to see if the issue can be resolved by following outlined procedures.

Visit <https://www.vertiv.com/en-us/support/> for additional assistance.

TABLE OF CONTENTS

Admonishments Used in this Document	iv
Important Safety Instructions	v
Safety Admonishments Definitions.....	v
Safety and Regulatory Statements.....	v
Déclarations de Sécurité et de Réglementation.....	v
1 Customer Documentation Package	1
2 System Description	1
2.1 Lists 100, 101, 102, 103, and 203.....	1
2.2 Lists 500, 501, 502, and 503.....	2
3 Physical Security	4
4 Operating Procedures	4
4.1 Controller, Rectifiers, and Converters.....	4
4.2 ESTOP Function.....	4
4.3 Controller Battery Charge Current Limit Feature.....	5
4.4 Local Controls and Indicators.....	5
4.4.1 Controller, Rectifiers, and Converters.....	5
4.4.2 Distribution Cabinet.....	5
5 Maintenance	8
5.1 System Maintenance Procedures.....	8
5.2 Adding a Rectifier or Converter Module to an Existing Module Mounting Assembly Spec. No. 588705300.....	8
5.3 Installing a Field Expansion Module Mounting Assembly Spec. No. 588705300.....	11
5.4 Reconfiguring a Dual Voltage Distribution Panel (List DJ, FG, and FK).....	16
5.4.1 Removing the Distribution Panel.....	16
5.4.2 Reworking the Distribution Panel.....	18
5.4.3 Replacing the Distribution Panel.....	24
6 Troubleshooting and Repair	25
6.1 Contact Information.....	25
6.2 Controller, Rectifiers, and Converters.....	25
6.3 Controller Configuration.....	25
6.4 System Troubleshooting Information.....	25
6.5 Replacement Information.....	26
6.6 Replacement Procedures.....	26
6.6.1 Replacing a Rectifier or Converter Module.....	26
6.6.2 Replacing the NCU Controller.....	26
6.6.3 Replacing a Distribution Device.....	27
6.6.4 Replacing a Distribution Panel (List AL, DJ, FG, and FK).....	29
6.6.5 Circuit Card Replacement Procedures.....	30
6.6.6 Replacing a Battery Disconnect Contactor.....	35
6.6.7 Replacing an SPD (Surge Protection Device) (if furnished).....	37

Admonishments Used in this Document



DANGER! Warns of a hazard the reader *will* be exposed to that will *likely* result in death or serious injury if not avoided. (ANSI, OSHA)



WARNING! Warns of a potential hazard the reader *may* be exposed to that *could* result in death or serious injury if not avoided. This admonition is not used for situations that pose a risk only to equipment, software, data, or service. (ANSI)



CAUTION! Warns of a potential hazard the reader *may* be exposed to that *could* result in minor or moderate injury if not avoided. (ANSI, OSHA) This admonition is not used for situations that pose a risk only to equipment, data, or service, even if such use appears to be permitted in some of the applicable standards. (OSHA)



ALERT! Alerts the reader to an action that *must be avoided* in order to protect equipment, software, data, or service. (ISO)



ALERT! Alerts the reader to an action that *must be performed* in order to prevent equipment damage, software corruption, data loss, or service interruption. (ISO)



FIRE SAFETY! Informs the reader of fire safety information, reminders, precautions, or policies, or of the locations of fire-fighting and fire-safety equipment. (ISO)



SAFETY! Informs the reader of general safety information, reminders, precautions, or policies not related to a particular source of hazard or to fire safety. (ISO, ANSI, OSHA)

Important Safety Instructions

Safety Admonishments Definitions

Definitions of the safety admonishments used in this document are listed under “Admonishments Used in this Document” on page iv.

Safety and Regulatory Statements

Refer to Section 4154 (provided with your customer documentation) for Safety and Regulatory Statements.

Déclarations de Sécurité et de Réglementation

Reportez-vous à la Section 4154 (fourni avec les documents de votre client) pour les déclarations de sécurité et de réglementation.

This page intentionally left blank.

1 Customer Documentation Package

This document (UM582127000100) provides *User Instructions* for Vertiv™ NetSure™ -48 VDC Power System Model 7100, Spec. No. 582127000, Lists 100, 101, 102, 103, 203, 500, 501, 502, and 503 only.

The complete Customer Documentation Package for Lists 100, 101, 102, 103, 203, 500, 501, 502, and 503 consists of...

NetSure -48 VDC Power System Installation Manual

- Power System Installation Instructions: IM582127000100

NetSure -48 VDC Power System User Manual

- Power System User Instructions: UM582127000100

NetSure NCU Controller User Manual

- NCU Controller User Instructions: UM1M830BNA

USB Drive with All Customer Documentation for 582127000

Applicable documents for this system are as follows.

- Power System Installation Instructions: IM582127000100 (instructions for Lists 100, 101, 102, 103, 203, 500, 501, 502, and 503)
- Power System User Instructions: UM582127000100 (instructions for Lists 100, 101, 102, 103, 203, 500, 501, 502, and 503)
- NCU Controller User Instructions: UM1M830BNA
- Rectifier Instructions: UM1R482000e3
- -48 VDC to +24 VDC Converter Instructions: UM1C48241500
- -48 VDC to -58 VDC Converter Instructions: UM1C48582000P3
- Power System "System Application Guide": SAG582127000
- Engineering Drawings
- Also provided on the USB drive is a controller configuration drawing and the controller configuration files loaded into the controller as shipped.

2 System Description

2.1 Lists 100, 101, 102, 103, and 203

-48 VDC @ 1000 A and +24 VDC @ 500 A Power System

Lists 100, 101, 102, 103, and 203 of NetSure 7100 DC Power System are integrated power systems containing -48 VDC rectifiers, +24 VDC converters, intelligent control, metering, monitoring, and distribution.

This power system is designed to power a load while charging a positive grounded battery. This power system is capable of operating in a batteryless installation or off battery for maintenance purposes. The power system is designed for operation with the positive output grounded.

List 100, 103, and 203 of NetSure 7100 DC Power System consist of the following components mounted in a 7'0" x 23" relay rack, List 101 is mounted in 5'0" x 23" relay rack, and List 102 is mounted in a 6'0" x 23" relay rack.

Distribution Cabinet

A 3-row distribution cabinet is provided. The distribution cabinet is equipped with manual battery disconnect. Installed in the distribution cabinet are one (1) List DJ distribution panel and two (2) List AL distribution panels. See SAG582127000 for descriptions.

The distribution cabinet also houses one (1) IB2 controller interface board, one (1) optional EIB controller extended interface board, the IB5 second Ethernet port board, and the system interface board. See SAG582127000 for descriptions.



NOTE! *IB5 boards with a 10M/100M/1G Ethernet port replaced IB4 boards with a 10M/100M Ethernet port. This transition enables the support of connected devices that communicate up to 1G. While both boards are physically interchangeable, the IB5 board does require the NCU to have V1.2.80 or higher software loaded.*

NCU (NetSure Control Unit) Controller

The controller provides power system control, rectifier control (including a charge control function), converter control, metering functions, monitoring functions, and local/remote alarm functions. The controller also supports rectifier temperature compensation if the system is equipped with a temperature probe(s). Temperature probe(s) may also be designated to monitor ambient temperature and/or battery temperature. The controller also provides data acquisition, system alarm management, and advanced battery and energy management. The controller contains a color LCD display and keypad for local access. The controller provides an Ethernet port and comes with comprehensive webpages for remote access. The controller has SNMP v3 capability for remote system management. The controller supports software upgrade via its USB port. Refer to the NCU Controller Instructions (UM1M830BNA) for more information.

Rectifier Modules

The system contains rectifier modules, which provide load power, battery float current, and battery recharge current during normal operating conditions. Refer to the Rectifier Instructions (UM1R482000e3) for more information.

-48 VDC to +24 VDC DC-DC Converter Modules

Where +24 VDC load power is also required, -48 VDC to +24 VDC DC-DC converter modules are available. Refer to the Converter Instructions (UM1C48241500) for more information.

List 100

List 100 provides zero (0) battery tray.

List 101

List 101 provides one (1) battery tray.

List 102

List 102 provides two (2) battery trays.

List 103

List 103 provides three (3) battery trays.

List 203

List 203 provides three (3) battery trays.

2.2 Lists 500, 501, 502, and 503

-48 VDC @ 1000 A and -58 VDC @ 500 A Power System

Lists 500, 501, 502, and 503 of NetSure 7100 DC Power System are integrated power systems containing -48 VDC rectifiers, -58 VDC converters, intelligent control, metering, monitoring, and distribution.

This power system is designed to power a load while charging a positive grounded battery. This power system is capable of operating in a batteryless installation or off battery for maintenance purposes. The power system is designed for operation with the positive output grounded.

List 500 and 503 of NetSure 7100 DC Power System consist of the following components mounted in a 70" x 23" relay rack, List 501 is mounted in 5'0" x 23" relay rack, and List 502 is mounted in a 6'0" x 23" relay rack.

Distribution Cabinet

A 3-row distribution cabinet is provided. The distribution cabinet is equipped with manual battery disconnect. Installed in the distribution cabinet are one (1) List FJ distribution panel and two (2) List AL distribution panels. See SAG582127000 for descriptions.

The distribution cabinet also houses one (1) IB2 controller interface board, one (1) optional EIB controller extended interface board, the IB5 second Ethernet port board, and the system interface board. See SAG582127000 for descriptions.

NCU (NetSure Control Unit) Controller

The controller provides power system control, rectifier control (including a charge control function), converter control, metering functions, monitoring functions, and local/remote alarm functions. The controller also supports rectifier temperature compensation if the system is equipped with a temperature probe(s). Temperature probe(s) may also be designated to monitor ambient temperature and/or battery temperature. The controller also provides data acquisition, system alarm management, and advanced battery and energy management. The controller contains a color LCD display and keypad for local access. The controller provides an Ethernet port and comes with comprehensive webpages for remote access. The controller has SNMP v3 capability for remote system management. The controller supports software upgrade via its USB port. Refer to the NCU Controller Instructions (UM1M830BNA) for more information.

Rectifier Modules

The system contains rectifier modules, which provide load power, battery float current, and battery recharge current during normal operating conditions. Refer to the Rectifier Instructions (UM1R482000e3) for more information.

-48 VDC to -58 VDC DC-DC Converter Modules

Where -58 VDC load power is also required, converter modules are available. These converters operate from the main -48 VDC system bus to provide -58 VDC load power. Refer to the Converter Instructions (UM1C48582000P3) for more information.

List 500

List 500 provides zero (0) battery tray.

List 501

List 501 provides one (1) battery tray.

List 502

List 502 provides two (2) battery trays.

List 503

List 503 provides three (3) battery trays.

3 Physical Security

This product is designed and intended to be deployed and operated in a physically secure and network firewall-protected location. Vertiv recommends a review of the physical security and operating environment of the unit. Since an attacker or disgruntled user can cause serious disruption, below are some recommended best practices that include, but are not limited to:

- Restrict access to areas, racks, and units with encrypted card RFID/badges, unique multi-factor passcode authentication for access, man traps, and biometric scanners for physical access to the equipment.
- Have trusted and background-checked security guards with 24x7x365 physical presence and written logs to help document and note physical access to a data center, building, rack, and so on.
- Restrict physical access to telecommunications equipment and network cabling. Physical access to the telecommunications lines and network cabling should be restricted to protect against attempts to intercept or sabotage communications. Best practices include use of metal conduits for the network cabling running between equipment cabinets.
- All USB, RJ45, and/or any other physical ports should be restricted on the units.
- Do not connect removable media (such as USB devices, SD cards, and so on) for any operation (such as firmware upgrade, configuration change, or boot application change) unless the origin of media is known and trusted. Before connecting any portable device through a USB port or SD card slot, scan the device for malware and viruses.

4 Operating Procedures

4.1 Controller, Rectifiers, and Converters

For operation instructions on these units, refer to the following documents.

- NCU Controller Instructions (UM1M830BNA)
- Rectifier Instructions (UM1R482000e3)
- -48 VDC to +24 VDC Converter Instructions (UM1C48241500)
- -48 VDC to -58 VDC Converter Instructions (UM1C48582000P3)

4.2 ESTOP Function

If an ESTOP switch is wired to the IB2-1 Controller Interface Board, customer-furnished system ground applied to terminal D18+ activates the ESTOP function. The ESTOP function shuts down and locks out the rectifiers, shuts down and locks out the optional -48 VDC to +24 VDC converters or -48 VDC to -58 VDC converters, and opens the optional low voltage disconnect (LVD) contactors (battery and load type). If the system has battery connected and does not contain a battery LVD or the controller power option is set to Battery Pwr (jumper J3 on the system interface board is set to Battery Pwr), the controller will remain operational. If the system does not contain battery or load LVD(s) and has battery connected, the loads will be sustained by the battery voltage.

For Systems NOT Containing a Battery LVD: When the ESTOP signal is removed, LVD contactors (battery and load type) will close after the “LVD Reconnect Delay” has elapsed (customer configurable via the controller) if battery voltage is present on the bus. Rectifiers and -48 VDC to +24 VDC converters or -48 VDC to -58 VDC converters will remain off. The rectifiers will restart when the input power is removed and restored after 30 seconds or more (until the LEDs on the modules extinguish). To restart the -48 VDC to +24 VDC converters or -48 VDC to -58 VDC converters: remove the converter, wait 30 seconds or more (until the LEDs on the converter extinguish), then re-insert the converter.

For Systems Containing a Battery LVD: When the ESTOP signal is removed, LVD contactors (battery and load type) will remain open. Rectifiers and -48 VDC to +24 VDC converters or -48 VDC to -58 VDC converters will remain off. The rectifiers will restart when the input power is removed and restored after 30 seconds or more (until the LEDs on the modules extinguish). When the rectifiers restart, LVD contactors (battery and load type) will close after the “LVD Reconnect Delay” has elapsed (customer configurable via the controller) and the -48 VDC to +24 VDC converters or -48 VDC to -58 VDC converters will restart.



NOTE! If a customer-furnished method to disconnect the input power to the system is not provided, the rectifiers will stay locked OFF until the input power is recycled. If the ESTOP signal is removed without recycling the input power, the rectifiers will remain off and have a local alarm visible on the module. The ESTOP alarm from the controller will extinguish. The controller will not issue an alarm for this condition.

4.3 Controller Battery Charge Current Limit Feature

Functionality: After a failure of the input source (commercial AC) or when some battery cells are permanently damaged, the current to the batteries can be quite extensive. To avoid overheating or further damages to the battery, the controller can be programmed to limit the battery current to a preset level by limiting the charging voltage of the rectifiers. Should the battery current still exceed a higher preset value, an alarm is issued.

The controller limits the current going to the batteries based on the “Battery Current Limit” set point, which is a percentage of the battery capacity in C10. For example, 0.1C10 would mean 10% of the battery capacity.

Refer to the NCU Controller Instructions (UM1M830BNA) to program this feature. Battery charge current is limited to the value set in the controller, as long as battery voltage is above 47 VDC. The default value for battery recharge current limit is 0.1xC10.

4.4 Local Controls and Indicators

4.4.1 Controller, Rectifiers, and Converters

Refer to the controller, rectifier, and converter instructions for descriptions of the local controls and indicators located on these units.

4.4.2 Distribution Cabinet

Refer to this section for descriptions of the local controls and indicators located on the circuit cards installed in the distribution cabinet.

System Interface Board Indicator, Switch, and Test Points

The system interface board contains a manual battery disconnect switch and indicator. The board also contains test points to externally monitor system voltage. Refer to Figure 4.1 for circuit card location and Figure 4.2 for indicator, switch, and test points descriptions.



ALERT! Do not hold MBD switch (S1) in the up or down position for more than 3 seconds to avoid damaging the contactor.



ALERT! When using switch, after either pushing up or down let switch return to the center position for 3 seconds before pushing switch in the opposite direction to avoid damaging the contactor.

IB2 (Controller Interface Board) and Optional EIB (Controller Extended Interface Board) Indicator

The IB2 and optional EIB boards have a green LED indicator which is lit in normal operation and flashes when the IB2 or EIB board is communicating with the controller. Refer to Figure 4.1 for IB2 and EIB locations.

Figure 4.1 Circuit Card Locations

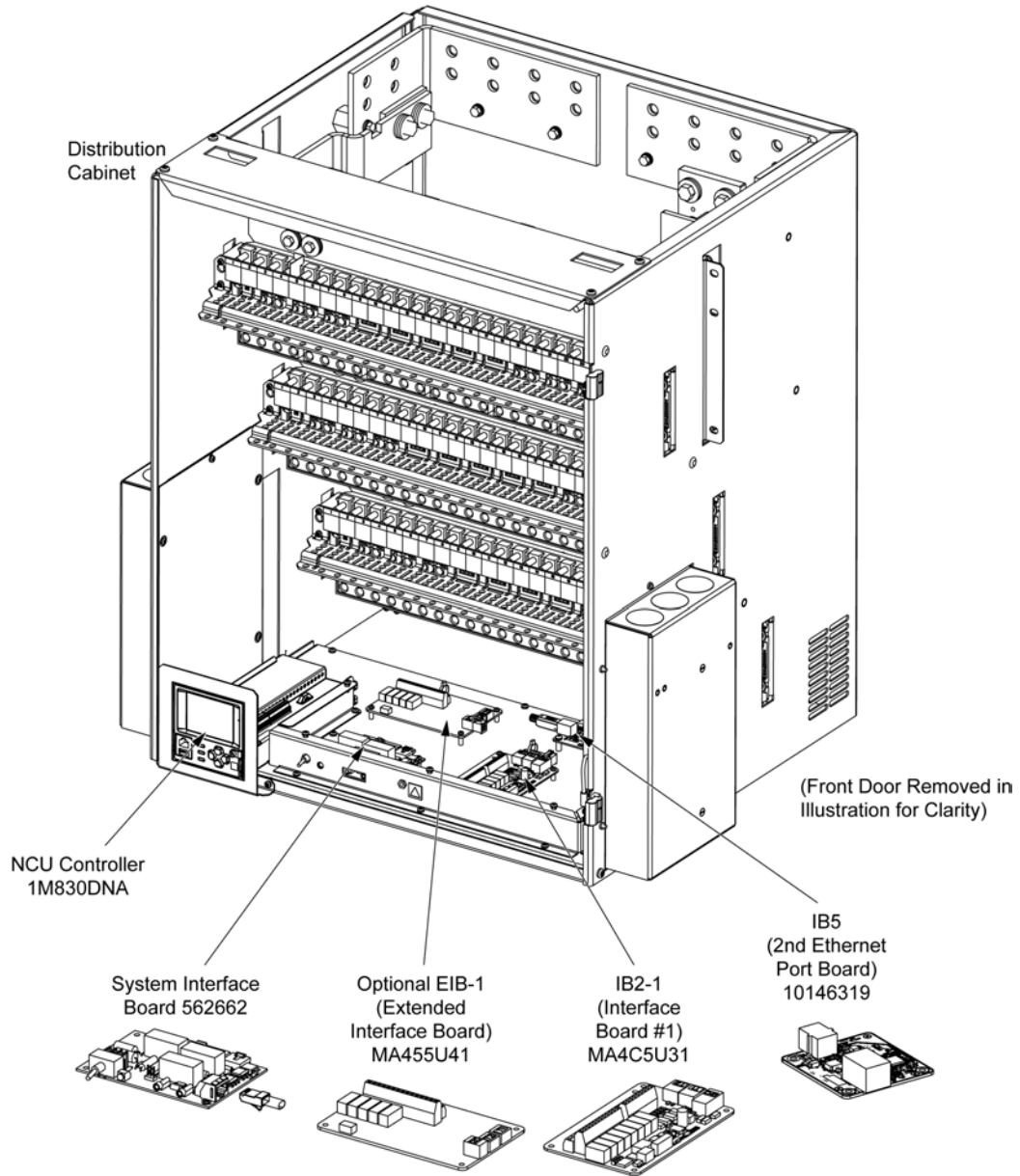
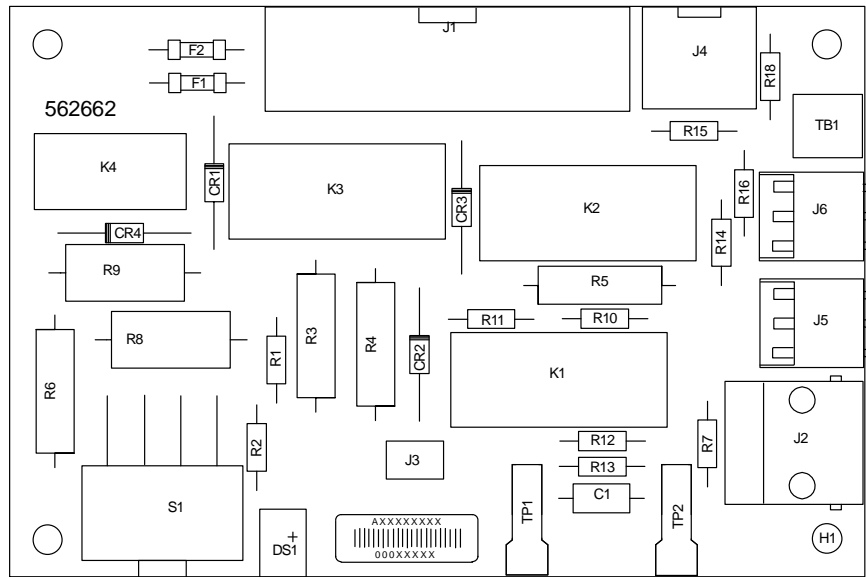

Figure 4.2 System Interface Board



Manual Battery Disconnect Switch

Manual Battery Disconnect Active Indicator

TP1 (-) and TP2 (+) System Voltage

Illuminates if the Battery Disconnect Contactor has been manually disconnected (placed in open position).

Momentary UP / Middle / Momentary Down

Momentary UP Position: Closes (latches in close position) the Battery Disconnect Contactor.

Middle Position: Normal Operation.

Momentary DOWN Position: Opens (latches in open position) the Battery Disconnect Contactor. Momentarily place switch in the UP position to close the contactor.

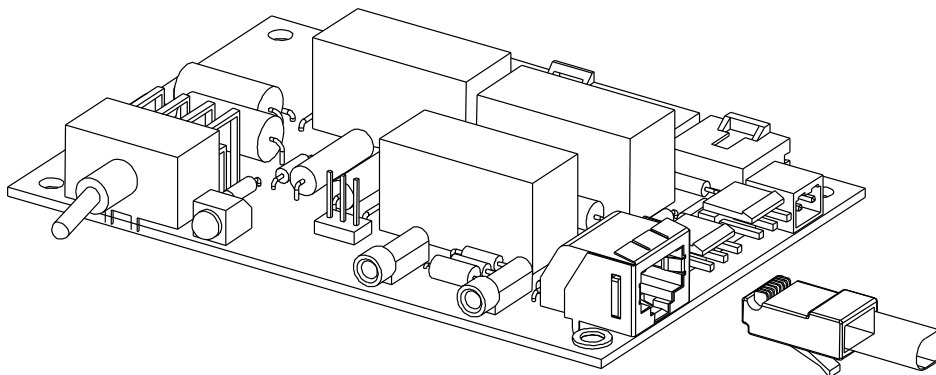

5 Maintenance

5.1 System Maintenance Procedures

It is recommended to perform the maintenance procedures listed in Table 5.1 every 6-months to ensure continual system operation.

Table 5.1 Maintenance Procedures to be Performed at 6-Month Intervals

Procedure	Referenced In
Check ventilation openings for obstructions such as dust, papers, manuals, etc.	--
Inspect and tighten all installer's connections.	IM582127000100, "Making Electrical Connections" section.

5.2 Adding a Rectifier or Converter Module to an Existing Module Mounting Assembly Spec. No. 588705300

To increase system current capacity, a rectifier module can easily be added to an existing module mounting assembly Spec. No. 588705300 that contains an empty rectifier module mounting position. Likewise, to increase subsystem capacity a -48 VDC to +24 VDC DC-DC converter module can be added to a module mounting assembly Spec. No. 588705300 that contains an empty -48 VDC to +24 VDC converter module mounting position. A -48 VDC to -58 VDC DC-DC converter module can be added to a module mounting shelf that contains an empty -48 VDC to -58 VDC converter module mounting position.

Rectifier and converter modules can be inserted or removed with power applied (hot swappable).

Rectifiers modules can be installed in any mounting position of each module mounting assembly. Converter modules can be installed in any of the three far right mounting positions of the three lower module mounting assemblies (as viewed from the front). See Figure 5.3. See Alerts below for restrictions.



NOTE! Each rectifier and converter module locks into the module mounting assembly by means of a latch located on the bottom of the module. The latch and module handle are interactive. Pushing the handle up into the module's front panel causes the latch to extend to the locking position; pulling the handle down out from the module's front panel causes the latch to retract. See Figure 5.3.



WARNING! To prevent damage to the latching mechanism, ensure the handle is in the open position when installing or removing a module. NEVER hold the handle in the closed position when installing a module into a shelf.



ALERT! The system can either have +24V DC-DC converters installed or -58V DC-DC converters installed. The system cannot have both types of converters installed at the same time.



ALERT! The -48 VDC to +24 VDC converter modules must only be installed in a system position that accepts a +24V DC-DC converter. Refer to labeling on the system's module mounting shelf. A sample of this labeling is provided in Figure 5.1.

Figure 5.1 Sample Module Mounting Shelf Labeling

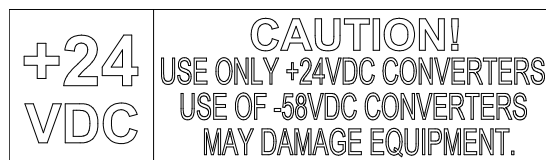



ALERT! The -48 VDC to -58 VDC converter modules must only be installed in a system position that accepts a -58V DC-DC converter. Refer to labeling on the system's module mounting shelf. A sample of this labeling is provided in Figure 5.2.

Figure 5.2 Sample Module Mounting Shelf Labeling

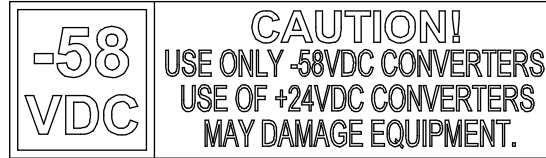

Procedure

1. Unpack the modules.
2. Note the model number located on the front of each module. Model numbers starting with the letter “R” are rectifier modules. Model numbers starting with the letter “C” are converter modules.
3. Place the module into an unoccupied mounting position without sliding it in completely. Rectifier modules can be installed in any mounting position of each module mounting assembly. Converter modules can be installed in any of the three far right mounting positions of the three lower module mounting assemblies (as viewed from the front). See Figure 5.3.
4. Loosen the captive screw on the module's handle. Pull the handle down out from the module's front panel (this will also retract the latch mechanism). See Figure 5.3.
5. Push the module completely into the shelf.
6. Push the handle up into the module's front panel. This will lock the module securely to the shelf. Tighten the captive screw on the handle.
7. Repeat the above steps for each module being installed in the system.
8. After the modules are physically installed in the module mounting assembly(s), they are ready for operation immediately after power is supplied to them.



NOTE! It is recommended that the current limit point be checked whenever a rectifier is added to or removed from the power system. Refer “Checking the Controller's Current Limit Point after Adding or Removing a Rectifier Module” on page 25.



NOTE! The rectifier or converter being added is assigned by the controller the lowest available identification number. If desired, you can change the identification number. Refer to the NCU Controller Instructions (UM1M830BNA) for a procedure.

Figure 5.3 Installing Rectifier and Converter Modules in a Spec. No. 588705300 Module Mounting Assembly

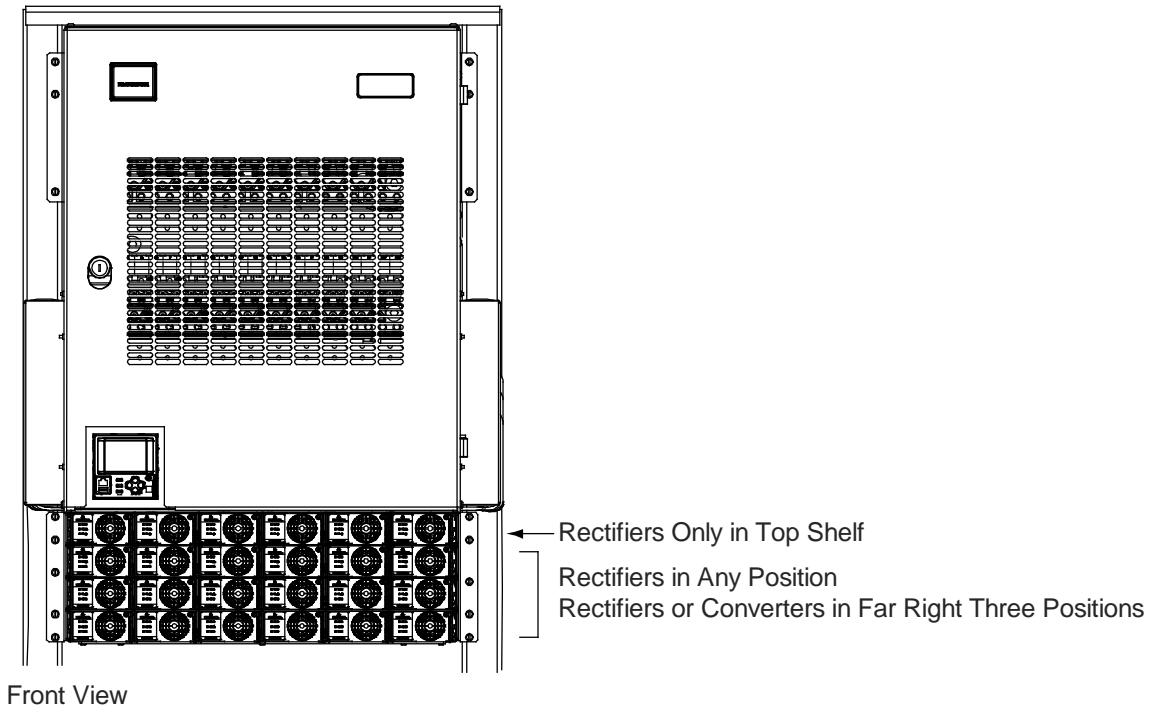

Rectifier or Converter Module

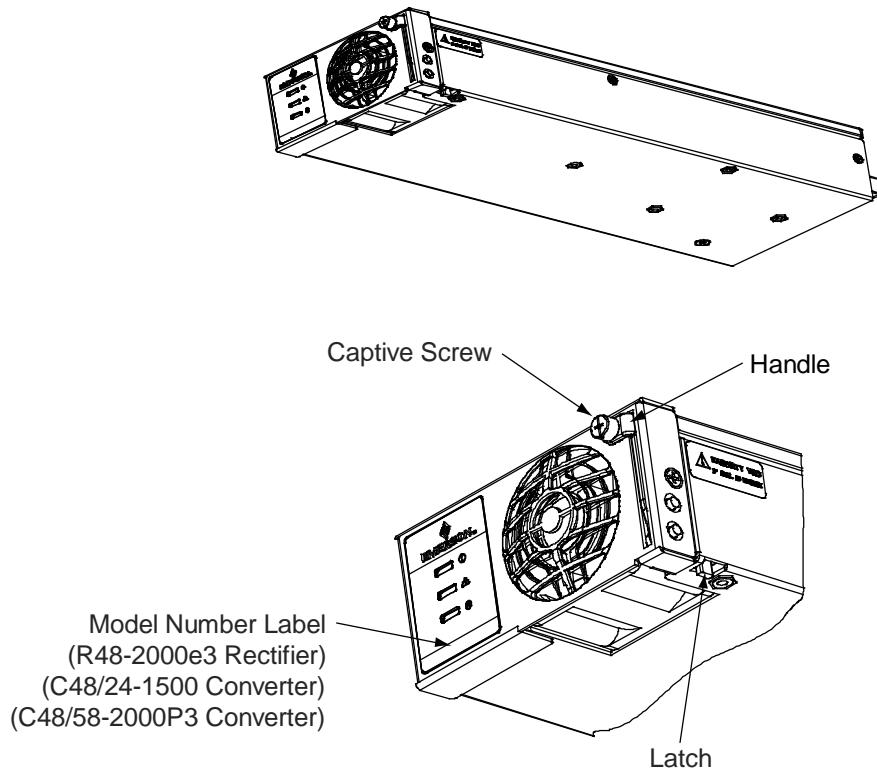

5.3 Installing a Field Expansion Module Mounting Assembly Spec. No. 588705300



DANGER! Adhere to the “Important Safety Instructions” presented at the front of this document.



CAUTION! During this procedure, the rectifiers in the bottom shelf will be disconnected from the system DC bus and should be de-energized or removed from the shelf before beginning the procedure.



NOTE! Refer to Figure 5.5 and Figure 5.6 as this procedure is performed.

Procedure

1. Remove the busbar rear shield from the existing module mounting assemblies. Remove the cut-out panel from the busbar rear shield by gently bending the panel until it snaps from the busbar rear shield.
2. Remove the hardware from the lowest module mounting assembly's -48V, return, and +24V or -58V (if present) busbars.
3. Install one (1) or two (2) expansion module mounting assemblies directly below the bottom-most module mounting assembly in the rack. Use the mounting hardware provided with the expansion module mounting assembly(s).

Hardware build-up is:

12-24 x 3/4" screw and flat washer, (1) set per side.

12-24 x 3/4" screw and ground washer, (1) set per side.



NOTE! Install the ground washers so the teeth make contact with the metal on the mounting angles. Torque all screws to 65 in-lbs.

4. Remove the busbar rear shield from the expansion module mounting assembly(s).



NOTE! Apply electrical anti-oxidizing compound to busbar mating surfaces before performing the next step.

5. Install the busbars provided with the expansion module mounting assembly(s) between the studs on the expansion module mounting assembly(s) and the studs on the shelf above it. Secure these busbars to the expansion module mounting assembly(s) with the hardware provided with the expansion module mounting assembly(s). Secure these busbars to the shelf above the expansion module mounting assembly with the hardware previously removed. Torque to 60 in-lbs.

Hardware build-up for these connections is:

M6 Nut,

M6 Belleville lock washer,

M6 flat washer.

6. If One Expansion Module Mounting Assembly Installed: Disconnect the connectors on the left rear (when viewed from the rear) of the bottom-most existing module mounting assembly. Connect these to the two connectors on the left rear (when viewed from the rear) of the expansion module mounting assembly. Refer to Figure 5.6,

7. **If Two Expansion Module Mounting Assemblies Installed:** Disconnect the connectors on the left rear (when viewed from the rear) of the bottom-most existing module mounting assembly. Connect one of these to the mating connector in the first expansion module mounting assembly. Connect the other connector from the bottom-most existing module mounting assembly to the mating connector in the second expansion module mounting assembly. Connect the remaining two connectors, one from each expansion module mounting assembly, together. Refer to Figure 5.6, second sketch.
8. Re-install the rear busbar shield previously removed from the existing module mounting assembly. Re-install the rear busbar shield previously removed from the expansion module mounting assembly(s).
9. Refer to the Power System Installation Instructions (IM582127000100) and connect AC input power to the expansion module mounting assembly to provide AC input for rectifiers, if needed.
10. Refer to the Power System Installation Instructions (IM582127000100) and install rectifier and converter modules into the expansion module mounting assembly as required.
11. For List 33, two sets of converter polarity caution labels are provided loose. Based on the converter output voltage, apply the correct label to right three converter slots of the expansion shelf: +24V label 60028788 for use with +24VDC converters; -58V label 60028735 for use with -58VDC converters. A sample of this labeling is provided in Figure 5.4.

Figure 5.4 Caution Labels



60028788 (+24V Label)

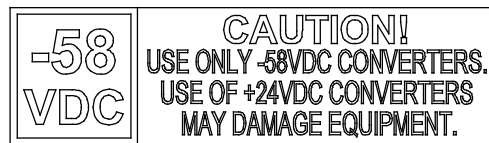

60028735 (-58V Label)

Figure 5.5 Installing a Field Expansion Module Mounting Assembly Spec. No. 588705300

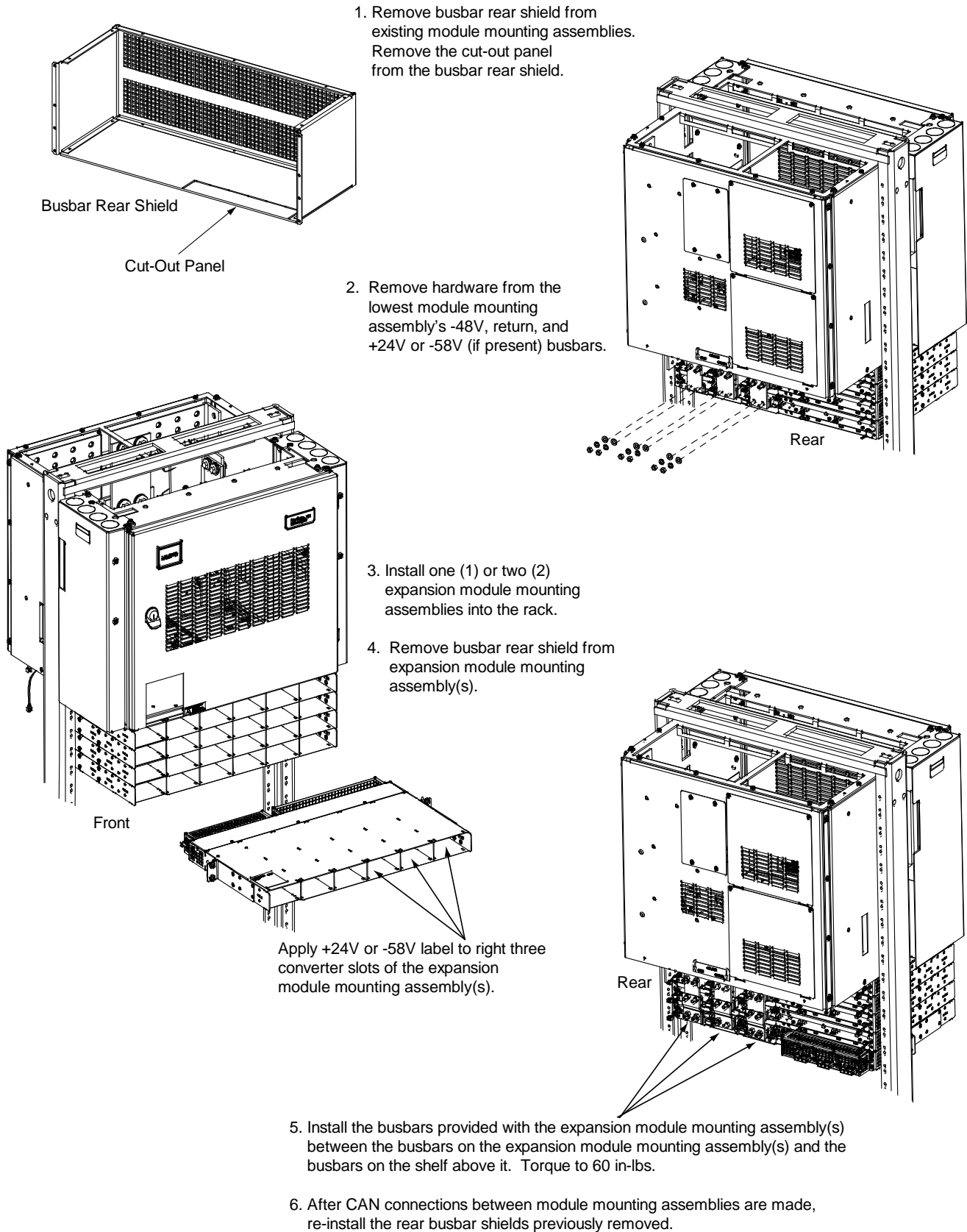
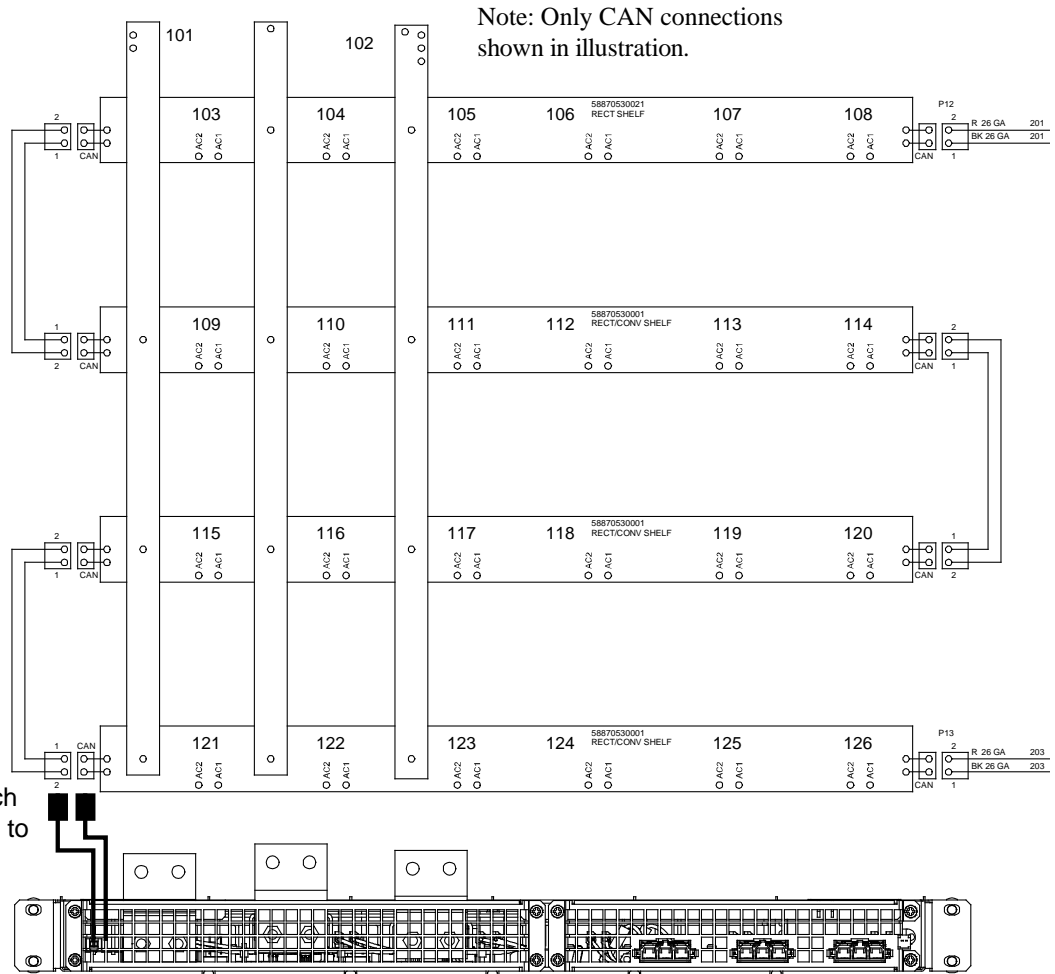

Figure 5.6 Controller CAN Bus, Module Mounting Assembly Spec. No. 588705300 (cont'd on next page)



These connectors should be disconnected from each other and then connected to the two connectors in the expansion module mounting assembly as shown.

Expansion Module Mounting Assembly

Rear View

Figure 5.6 Controller CAN Bus, Module Mounting Assembly Spec. No. 588705300 (cont'd from previous page)

Note: Only CAN connections shown in illustration.

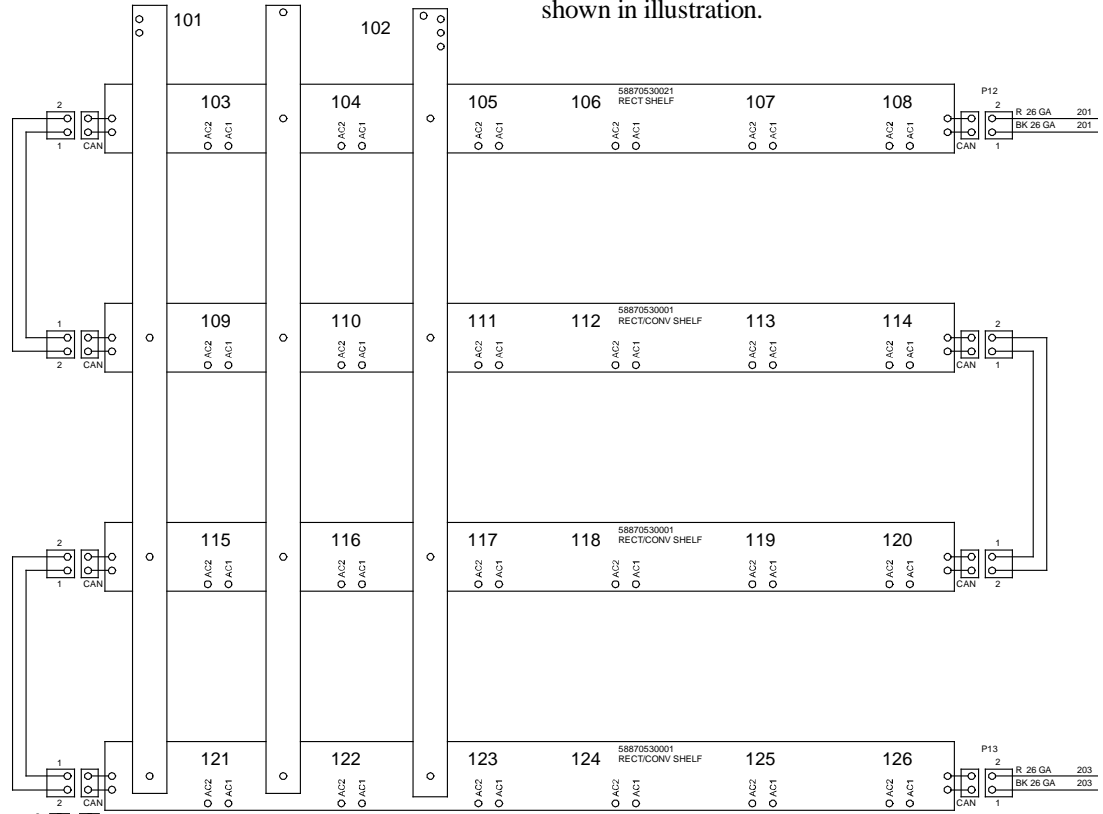

These connectors should be disconnected from each other and then connected to the connectors from the expansion module mounting assembly as shown.

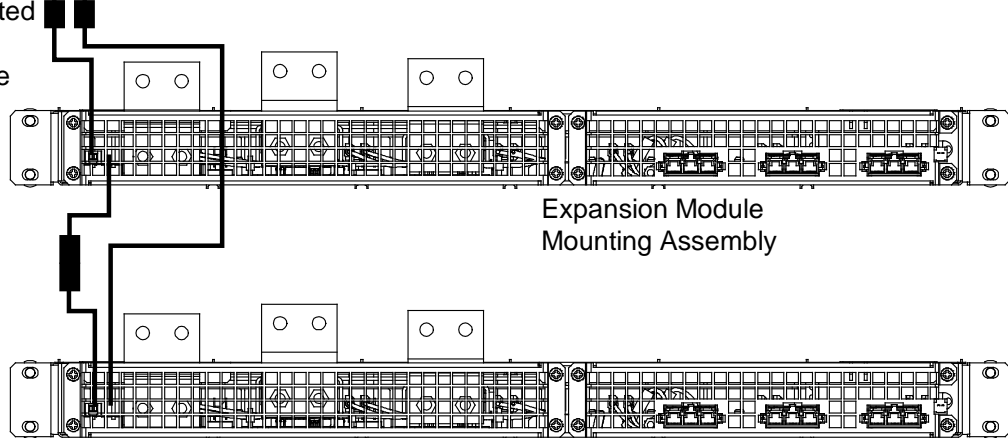

Rear View

5.4 Reconfiguring a Dual Voltage Distribution Panel (List DJ, FG, and FK)

Perform the following procedure to reconfigure a dual voltage distribution panel (List DJ, FG, and FK) to move distribution positions from one voltage to the other.



DANGER! Performing this procedure exposes service personnel to battery potential. Exercise extreme caution not to inadvertently contact or have any tool inadvertently contact any energized electrical termination.



NOTE! Save all removed hardware. Hardware will be re-used.

5.4.1 Removing the Distribution Panel

Procedure

1. Performing this procedure may activate external alarms. Do one of the following. If possible, disable these alarms. If these alarms cannot be easily disabled, notify the appropriate personnel to disregard any future alarms associated with this system while the procedure is being performed.
2. Open the distribution cabinet's front door by turning the latch in the counterclockwise position.
3. Remove the plastic shield covering the circuit breakers and/or fuseholders on the distribution panel to be removed by loosening the screws holding the shield and sliding the shield upwards.
4. Record circuit breaker and/or fuse positions and sizes.
5. Remove circuit breakers and/or fuseholders.
6. Label the load leads.
7. Disconnect and insulate all load leads from the circuit breaker and/or fuse positions.
8. Disconnect and insulate all load return leads from the ground busbar.
9. Refer to Figure 5.7 and remove the hardware securing the +24V or -58V jumper leads. Insulate and tie back these leads.
10. Refer to Figure 5.7 and locate the in-line FA/CBA connector located near the back of the distribution panel. Separate the connector halves.
11. Refer to Figure 5.7 and remove the hardware securing the distribution panel's ground busbar to the distribution cabinet's busbar.
12. Refer to Figure 5.7 and remove the hardware securing the distribution panel's system load distribution busbar to the distribution cabinet's busbar.
13. Refer to Figure 5.7 and remove the hardware securing the distribution panel to the distribution cabinet. Remove the distribution panel from the distribution cabinet.

Figure 5.7 Removing/Installing the Distribution Panel

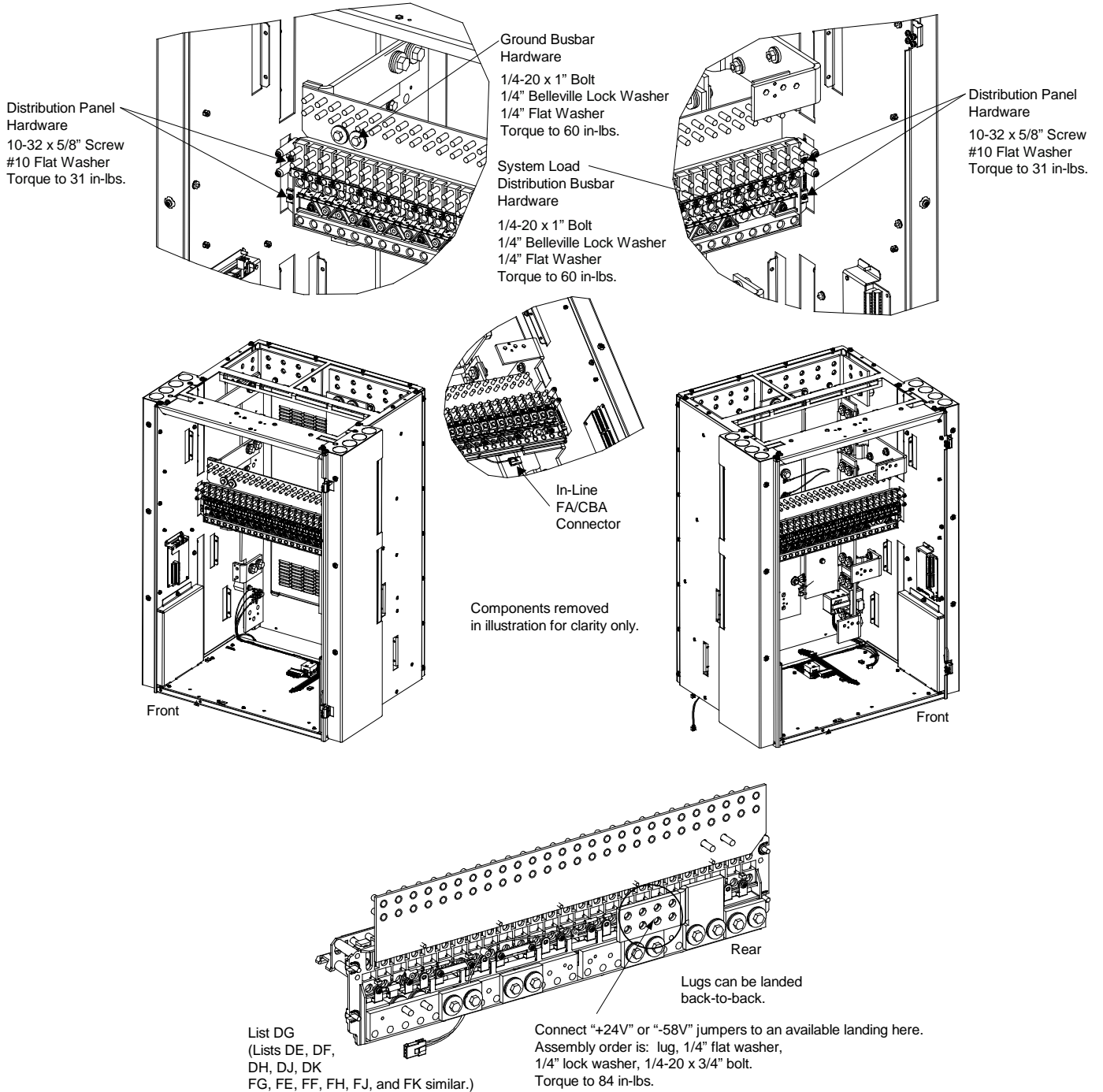

5.4.2 Reworking the Distribution Panel

You can reconfigure the distribution panel to swap -48V distribution positions for +24V or -58V distribution positions, and vice versa, in groups of four. The resulting assembly can have following positions. See Table 5.2.

Table 5.2 Positions

Positions	
(0) -48V	(26) +24V or -58V
(6) -48V	(20) +24V or -58V
(10) -48V	(16) +24V or -58V
(14) -48V	(12) +24V or -58V
(18) -48V	(8) +24V or -58V
(22) -48V	(4) +24V or -58V
(26) -48V	(0) +24V or -58V

You do this by moving the shorting bus and CBA/FA alarm strap. Refer to Figure 5.8 to reconfigure the distribution panel.

Note that for a List DE and FE distribution panel, you must also move the subsystem input power busbar as shown in Figure 5.8.

Note that if you reconfigure a distribution panel for all subsystem voltage (List DK or FK) or all system voltage, you must also move the extra CBA/FA alarm strap stored on the far left (as viewed from the rear) to the far right position (as shown in Figure 5.8).

Note that if you reconfigure a distribution panel for all subsystem voltage (List DK or FK), you must disconnect and insulate the system CBA/FA lead (as shown in Figure 5.8).

Note that if you reconfigure a distribution panel for all system voltage, you must disconnect and insulate the subsystem CBA/FA lead (as shown in Figure 5.8).

Figure 5.8 Reworking the Distribution Panel (cont'd on next page)

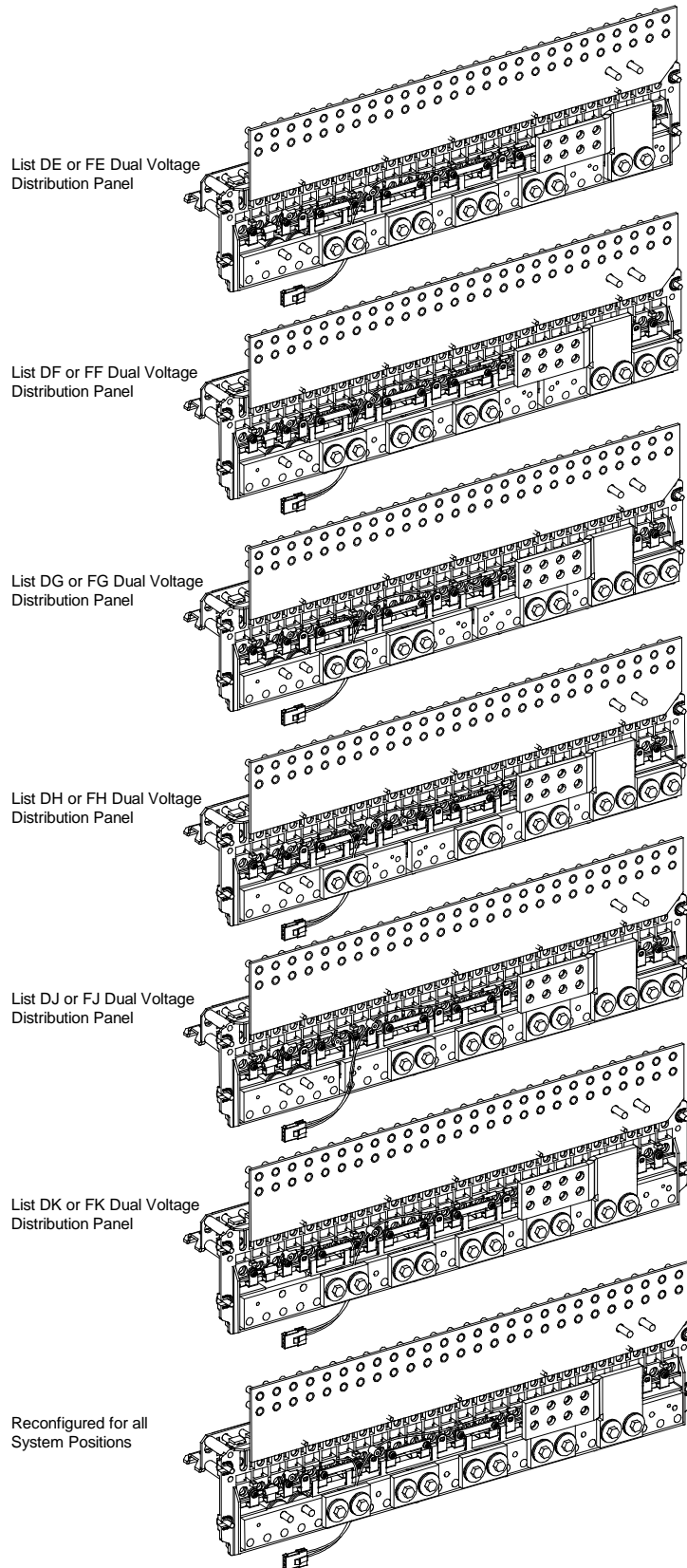

Figure 5.8 Reworking the Distribution Panel (cont'd from previous page, cont'd on next page)

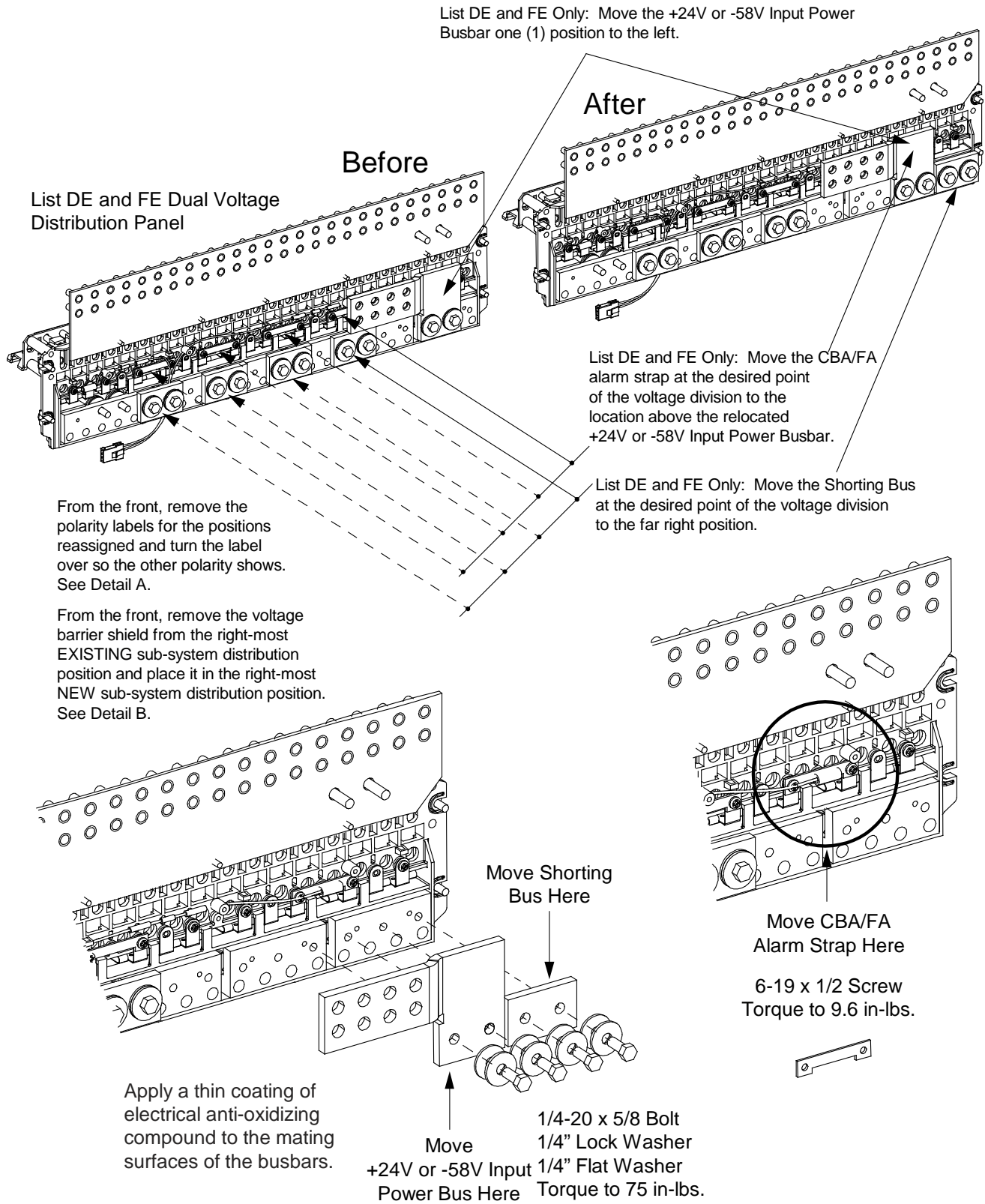

Figure 5.8 Reworking the Distribution Panel (cont'd from previous page, cont'd on next page)

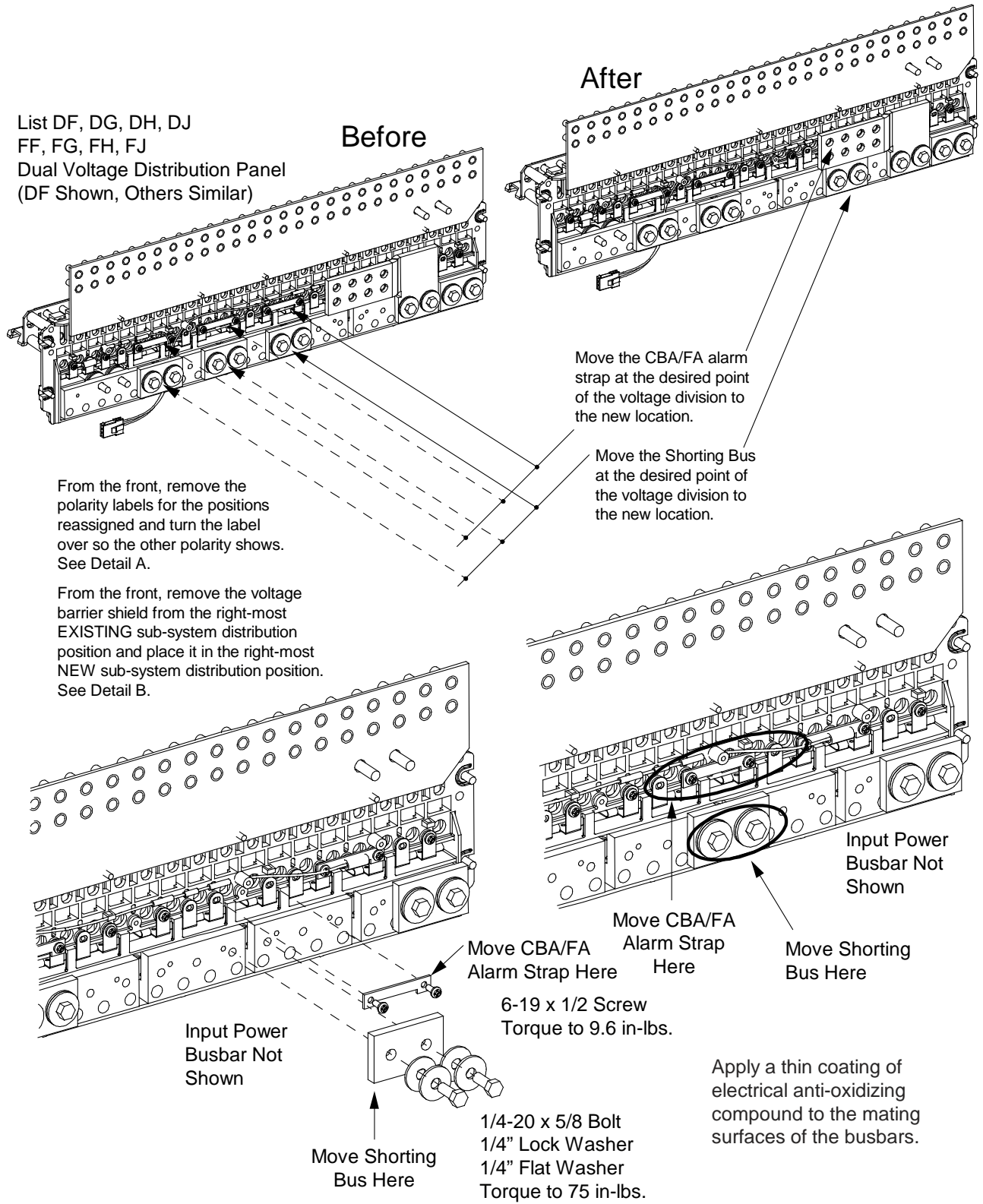

Figure 5.8 Reworking the Distribution Panel (cont'd from previous page, cont'd on next page)

Distribution Panel Reconfigured for All Subsystem (List DK) or All System Positions

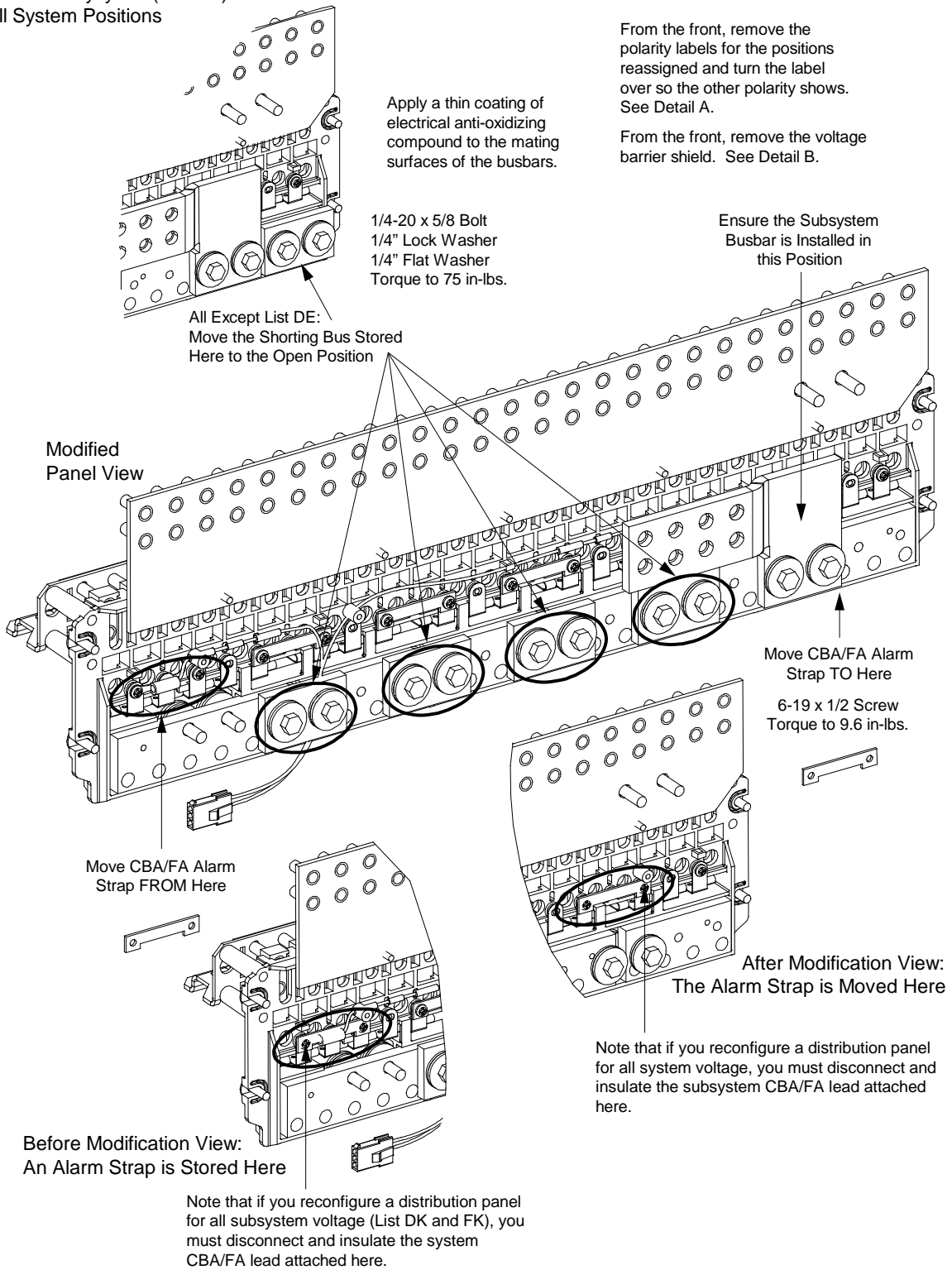
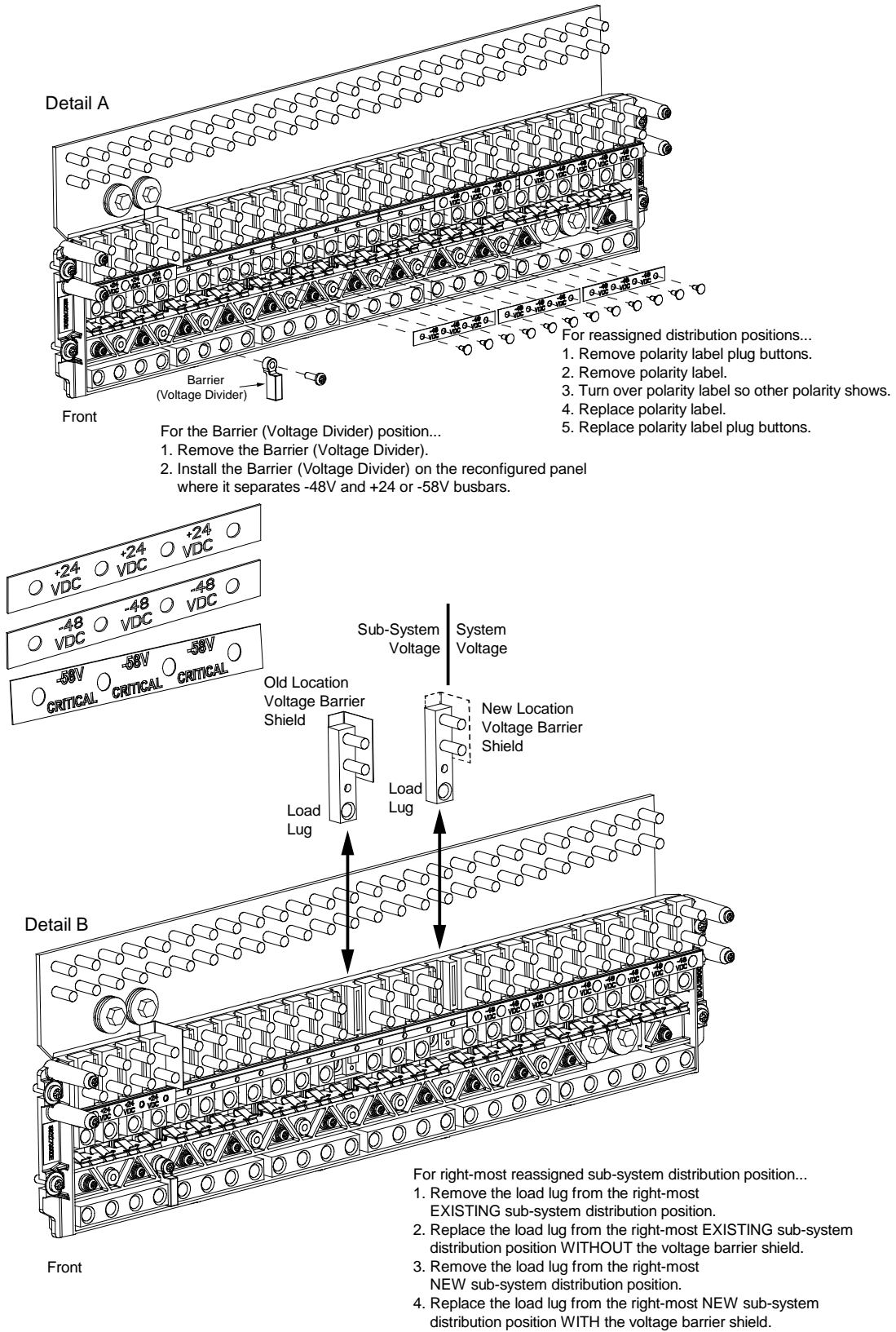

Figure 5.8 Reworking the Distribution Panel (cont'd from previous page)



5.4.3 Replacing the Distribution Panel



NOTE! In the following procedure, before making busbar-to-busbar connections, apply a thin coating of electrical anti-oxidizing compound to the mating surfaces of the busbars.

Procedure



NOTE! If the panel is re-configured for all subsystem positions (List DK or FK), the distribution cabinet's load side busbar must be removed since it is not to be connected to the distribution panel and will cause interference. Note that the busbar that is removed should be retained in the event that the panel is re-configured at a later date to revert back to a panel with some subsystem positions.

1. If the panel is re-configured for all subsystem positions, remove the distribution cabinet's load side busbar. Save this busbar and hardware for future use.
2. Orient the distribution panel into the distribution cabinet, checking to ensure no wires are pinched. Replace the hardware securing the distribution panel to the distribution cabinet. Refer to Figure 5.7 for hardware build-up. Torque as indicated in Figure 5.7.
3. Reconnect the +24V or -58V jumper leads. Refer to Figure 5.7 for hardware build-up. Torque as indicated in Figure 5.7. **For a panel re-configured to all -48V positions, the +24V or -58V jumper leads MUST not be used. They should be retained at the site for future use if necessary.**
4. In all except panels re-configured for all subsystem positions (List DK or FK), replace the hardware securing the distribution panel's system load distribution busbar to the distribution cabinet's busbar. Refer to Figure 5.7 for hardware build-up. Torque as indicated in Figure 5.7.
5. Replace the hardware securing the distribution panel's ground busbar to the distribution cabinet's busbar. Torque as indicated in Figure 5.7.
6. Plug the in-line FA/CBA connector located near the back of the distribution panel into the mating connector half in the distribution cabinet. Refer to Figure 5.7.



WARNING! In the next step, observe correct polarity; otherwise, equipment damage will result.

7. Reconnect the load return leads to the ground busbar.
8. Reconnect the load leads to the circuit breaker and/or fuse positions.
9. Replace the circuit breakers and/or fuseholders.
10. Replace the plastic shield covering the circuit breakers and/or fuseholders on the distribution panel.
11. Verify no circuit breaker/fuse alarms are active.
12. Close the distribution cabinet's front door. Turn the latch clockwise to secure the door.
13. Ensure that there are no local or remote alarms active on the system.

6 Troubleshooting and Repair

6.1 Contact Information

Refer to Section 4154 (provided with your customer documentation) for support contact information.

6.2 Controller, Rectifiers, and Converters

For troubleshooting and repair instructions on these units, refer to the following documents.

- NCU Controller Instructions (UM1M830BNA)
- Rectifier Instructions (UM1R482000e3)
- -48 VDC to +24 VDC Converter Instructions (UM1C48241500)
- -48 VDC to -58 VDC Converter Instructions (UM1C48582000P3)

6.3 Controller Configuration

If any controller configuration settings were changed, refer to the NCU Controller Instructions (UM1M830BNA) and save a copy of the configuration file. This file can be used to restore the controller settings, if required, at a later date.

- Note that provided on a USB drive furnished with the system is a controller configuration drawing (C-drawing) and the controller configuration files loaded into the controller as shipped.

6.4 System Troubleshooting Information

This system is designed for ease in troubleshooting and repair. The various indicators as described in “Local Controls and Indicators” on page 5 and in the controller, rectifier, and converter instructions are designed to isolate failure to a specific element. Once the faulty element has been identified, refer to “Replacement Information” on page 26 and “Replacement Procedures” on page 26.

Troubleshooting Alarm Conditions on the Controller

The controller displays alarm conditions as listed in the “Resolving Alarms” section of the controller’s User Manual. Programmable external alarm relays are also available. Refer to the System Installation Instructions (IM582127000100) and the configuration drawing (C-drawing) supplied with your power system documentation for your alarm relay configurations.

The controller’s *Active Alarm* and *Alarm History* submenus allow the User to view alarm details. Refer to the NCU Controller Instructions (UM1M830BNA) to access these menus.

Checking the Controller’s Current Limit Point after Adding or Removing a Rectifier Module

If a rectifier module is added to the power system, the system current limit point will automatically increase by the percentage each existing rectifier was set to provide prior to the addition.

If a rectifier module is removed from the system (and the Rect Comm Fail alarm is reset), the current limit point will remain unchanged unless the capacity of the remaining rectifiers is not sufficient to maintain the present current limit point. If that happens, the current limit point will automatically increase to the maximum (121% of the remaining rectifiers).

It is recommended that the current limit point be checked whenever a rectifier module is added to or removed from the power system.

When setting total rectifier current limit, the set point to each rectifier is the total set point divided by the number of rectifiers. For example, if the system contains five rectifiers and the current limit is set to 150 amps then each rectifier has a current limit set point of 30 amps. If one or more rectifiers are removed or fail it will take several seconds for the individual set points to the remaining rectifiers to be reset. In the example given, if one rectifier is removed the current limit set point will drop to 120 amps (30 amps times four remaining rectifiers) until the controller can send updated set points to the remaining rectifiers.

This takes a couple communication cycles (several seconds) after which each rectifier would have a new set point of 37.5 amps for a total of 150 amps. The total current limit of the rectifiers should not be set such that the loss of the redundant rectifiers will cause this temporary set point to drop below the actual maximum expected load. If batteries are used on the rectifier output, the batteries should support the load until the current limit set points can be re-established due to loss of a rectifier.

Refer to the NCU Controller Instructions (UM1M830BNA) for a procedure.

Clearing a Rectifier Communications Fail Alarm after Removing a Rectifier

If a rectifier module is removed from the system, a rectifier communications failure alarm is generated. If the rectifier module will not be replaced, the alarm should be cleared.

Refer to the NCU Controller Instructions (UM1M830BNA) for a procedure.

Clearing a Converter Communications Fail Alarm after Removing a Converter

If a converter module is removed from the system, a converter communications failure alarm is generated. If the converter module will not be replaced, the alarm should be cleared.

Refer to the NCU Controller Instructions (UM1M830BNA) for a procedure.

Clearing a Rectifier Lost Alarm

If the controller resets while a rectifier communications fail alarm is active, the rectifier communications fail alarm is replaced with a rectifier lost alarm.

Refer to the NCU Controller Instructions (UM1M830BNA) for a procedure to clear the alarm.

Clearing a Converter Lost Alarm

If the controller resets while a converter communications fail alarm is active, the converter communications fail alarm is replaced with a converter lost alarm.

Refer to the NCU Controller Instructions (UM1M830BNA) for a procedure to clear the alarm.

6.5 Replacement Information

Replacement Assemblies

When a trouble symptom is localized to a faulty rectifier module, converter module, controller, or system circuit card; that particular device or circuit card should be replaced in its entirety. No attempt should be made to troubleshoot or repair individual components on any rectifier module, converter module, controller, or circuit card.

Refer to SAG582127000 (System Application Guide) for replacement part numbers.

6.6 Replacement Procedures



DANGER! Adhere to the “Important Safety Instructions” presented at the front of this document.

6.6.1 Replacing a Rectifier or Converter Module

Refer to the Rectifier User Instructions (UM1R482000e3) or Converter User Instructions (UM1C48241500) for a rectifier and converter module replacement procedure. Refer also to “System Troubleshooting Information” on page 25.

The rectifier or converter module being replaced is assigned by the controller the lowest available identification number. If desired, you can change the identification number. Refer to the NCU Controller Instructions (UM1M830BNA) for a procedure.

6.6.2 Replacing the NCU Controller

Refer to the NCU Controller Instructions (UM1M830BNA) for a controller replacement procedure.

6.6.3 Replacing a Distribution Device

General

Replace distribution devices with the same type and rating. Refer to System Application Guide SAG582127000 for part numbers.

Distribution Fuse “Alarm Fuse” Replacement

If a distribution fuse opens, the associated alarm fuse opens. Replace the distribution fuse before replacing the alarm fuse.

Procedure

1. An alarm fuse is removed by pulling it straight out of the fuseholder. If the alarm fuse is located in a modular fuse carrier, hold the fuse carrier in place with your thumb while pulling on the alarm fuse to prevent the entire carrier from inadvertently being pulled out.
2. Safety fuse covers are provided for all Bussmann GMT type fuses installed in the system. These covers snap onto the fuses and provide protection from exposed electrical terminations when a fuse opens. Insure that the safety fuse cover is installed after replacing a fuse. Refer to Figure 6.1 for installation details.

Figure 6.1 Installation of Safety Fuse Covers

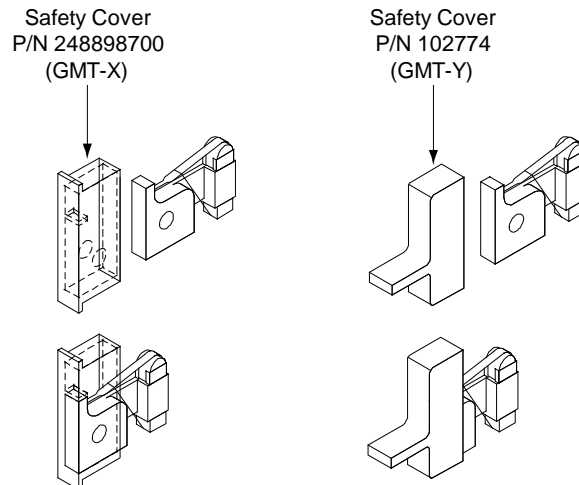

Replacing a TPS/TLS Fuse

Procedure



NOTE! Refer to Figure 6.2 as this procedure is performed.

1. Open the distribution cabinet's front door by turning the latch in the counterclockwise position.
2. Remove the fuse carrier from the mounted fuseholder body by pulling it straight out. Hold the fuseholder body while you pull the fuse carrier from the body.
3. Remove the open fuse from the fuse carrier and replace it with the same type and rating.
4. Replace the alarm fuse located in the front of the fuse carrier with the same type and rating. Ensure that a plastic safety cover is installed on the alarm fuse.
5. Push the fuse carrier securely back into the mounted fuseholder body. Note that a polarizing key on the bottom of the carrier prevents the carrier from being inserted upside down.
6. Verify no Fuse Alarms are active.
7. Close the distribution cabinet's front door. Turn the latch clockwise to secure the door.

Replacing a Bullet Nose Fuseholder

Procedure



NOTE! Refer to Figure 6.2 as this procedure is performed.

1. Open the distribution cabinet's front door by turning the latch in the counterclockwise position.
2. Remove the fuse carrier from the mounted fuseholder body by pulling it straight out. Hold the fuseholder body while you pull the fuse carrier from the body.
3. Gently rock the defective fuseholder up and down while pulling firmly outward until the fuseholder is free from the distribution panel.
4. Orient the replacement fuseholder as shown in Figure 6.2. Insert the terminals on the rear of the fuseholder into their corresponding sockets on the distribution panel. Ensure the alarm contact on the back of the fuseholder makes contact with the alarm terminal on the spring strip. Push fuseholder in firmly until fully seated in the distribution panel.
5. Push the fuse carrier securely back into the mounted fuseholder body. Note that a polarizing key on the bottom of the carrier prevents the carrier from being inserted upside down.
6. Verify no Fuse Alarms are active.
7. Close the distribution cabinet's front door. Turn the latch clockwise to secure the door.

Figure 6.2 Replacing a TPS/TLS Fuseholder and/or Fuse

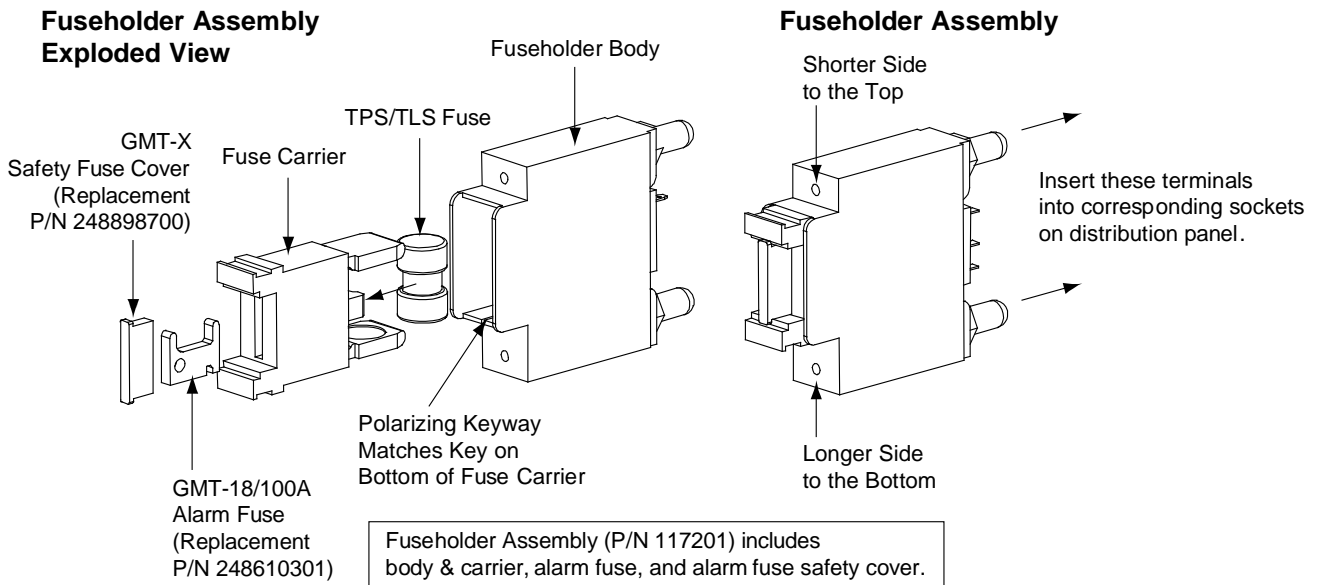

Replacing a Bullet Nose Circuit Breaker

Procedure



NOTE! Refer to Figure 6.3 as this procedure is performed.

1. Open the distribution cabinet's front door by turning the latch in the counterclockwise position.
2. Operate the defective circuit breaker to the OFF position.

3. Gently rock the defective circuit breaker up and down while pulling firmly outward until the breaker is free from the distribution panel.
4. Ensure that the circuit breaker is in the OFF position, and is of the correct rating.
5. Orient the replacement circuit breaker as shown in Figure 6.3. Insert the terminals on the rear of the circuit breaker into their corresponding sockets on the distribution panel. Ensure the alarm contact on the back of the circuit breaker makes contact with the alarm terminal on the spring strip. Push distribution device in firmly until fully seated in the distribution panel.
6. Operate the replacement circuit breaker to the ON position.
7. Verify no Circuit Breaker Alarms are active.
8. Close the distribution cabinet's front door. Turn the latch clockwise to secure the door.

Figure 6.3 Replacing a Bullet Nose Circuit Breaker

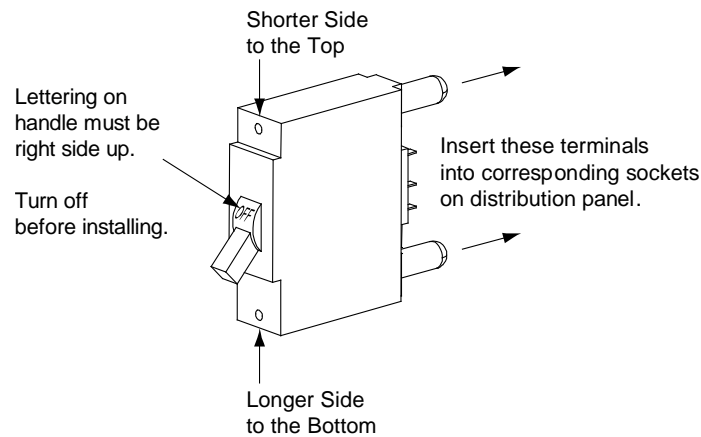

6.6.4 Replacing a Distribution Panel (List AL, DJ, FG, and FK)



DANGER! Performing the next steps exposes service personnel to battery potential. Exercise extreme caution not to inadvertently contact or have any tool inadvertently contact any energized electrical termination.

Procedure



NOTE! Refer to Figure 5.7 as this procedure is performed.

Removing the Distribution Panel

1. Open the distribution cabinet's front door by turning the latch in the counterclockwise position.
2. Remove the plastic shield covering the circuit breakers or fuseholders on the panel to be removed by loosening the screws holding the shield and sliding the shield upwards.
3. Disconnect and insulate all load wiring from the circuit breaker or fuse positions.
4. Remove all load return wiring from the ground busbar.
5. Locate the in-line FA/CBA connector located near the back of the panel, and separate the connector halves.
6. Refer to Figure 5.7 and remove the hardware securing the panel's Ground Busbar to the distribution cabinet's busbar.
7. Refer to Figure 5.7 and remove the hardware securing the panel's System Load Distribution busbar to the distribution cabinet's busbar.

8. **For dual voltage load distribution panels**, refer to Figure 5.7 and remove the hardware securing the +24V or -58V jumper leads.
9. Refer to Figure 5.7 and remove the hardware securing the distribution panel to the distribution cabinet. Remove the panel from the distribution cabinet.

Installing the Distribution Panel



NOTE! In the following procedure, before making busbar-to-busbar connections, apply a thin coating of electrical anti-oxidizing compound to the mating surfaces of the busbars.

1. Orient the replacement distribution panel into distribution cabinet, checking to ensure no wires are pinched. Replace the hardware securing the distribution panel to the distribution cabinet. Torque per Figure 5.7.
2. **For dual voltage load distribution panels**, replace the hardware securing the +24V or -58V jumper leads. Torque per Figure 5.7.
3. Replace the hardware securing the panel's System Load Distribution busbar to the distribution cabinet's busbar. Torque per Figure 5.7.
4. Replace the hardware securing the panel's Ground Busbar to the distribution cabinet's busbar. Torque per Figure 5.7.
5. Locate the in-line FA/CBA connector located near the back of the panel, and plug it into the mating connector half in the distribution cabinet.



WARNING! In the next step, observe correct polarity; otherwise equipment damage will result.

6. Reconnect the load return wiring to the ground busbar.
7. Reconnect the load wiring to the circuit breaker or fuse positions.
8. Transfer the plug-in circuit breakers or fuses from the old panel to the replacement panel.
9. Replace the plastic shield covering the circuit breakers or fuseholders on the replacement panel.
10. Verify no Circuit Breaker/Fuse Alarms are active.
11. Close the distribution cabinet's front door. Turn the latch clockwise to secure the door.

6.6.5 Circuit Card Replacement Procedures



WARNING! Circuit cards used in this power system contain static-sensitive devices. Read the Static Warning at the front of this document before performing any of the following procedures.

General

The following circuit card replacement procedures can be performed with the system operating.

Refer to Figure 4.1 for circuit card locations.



CAUTION! When performing any step in these procedures that requires removal or installation of hardware, use caution to ensure no hardware is dropped and left inside the cabinet; otherwise, service interruption or equipment damage may occur.



NOTE! When performing any step in these procedures that requires removal of existing hardware, retain all hardware for use in subsequent steps.



ALERT! Do not hold MBD switch (S1) in the up or down position for more than 3 seconds to avoid damaging the contactor.



ALERT! When using switch, after either pushing up or down let switch return to the center position for 3 seconds before pushing switch in the opposite direction to avoid damaging the contactor.

System Interface Board Replacement

Refer to Figure 4.1 for circuit card location.

Procedure

1. Performing this procedure may activate external alarms. Do one of the following. If possible, disable these alarms. If these alarms cannot be easily disabled, notify the appropriate personnel to disregard any future alarms associated with this system while the procedure is being performed.



DANGER! Performing the next steps exposes service personnel to battery potential. Exercise extreme caution not to inadvertently contact or have any tool inadvertently contact any energized electrical termination.

2. Open the distribution cabinet's front door by turning the latch in the counterclockwise position.



WARNING! Damage to the circuit card may result if the next step is not followed.

3. Connect an approved grounding strap to your wrist. Attach the other end to a suitable ground.
4. Remove the shield to access the circuit cards at the bottom of the distribution cabinet.
5. Carefully label the connectors plugged into the circuit card. These connectors must be plugged into the same connectors on the replacement circuit card. Refer to Figure 6.4.
6. Unplug all connectors plugged into the circuit card.
7. Remove the screws securing the circuit card and remove the circuit card from the distribution cabinet.
8. In this step, ensure you do not intermix the old and replacement circuit cards. Set the shorting jumper on the replacement circuit card to match the location on the old circuit card. Jumper settings are documented in the "Setting Jumpers and Switch Options" section of the Power System Installation Instructions (IM582127000100).
9. Slide the replacement circuit card into the mounting position inside the distribution cabinet, and secure with the screws removed from the old circuit card.
10. Plug all connectors removed from the old circuit card into the same position on the replacement circuit card.
11. Remove the grounding wrist strap.
12. Reinstall the shield that covers the circuit cards at the bottom of the distribution cabinet.
13. Close the distribution cabinet's front door. Turn the latch clockwise to secure the door.
14. Enable the external alarms, or notify appropriate personnel that this procedure is finished.
15. Ensure that there are no local or remote alarms active on the system.

Figure 6.4 System Interface Board Connector Locations

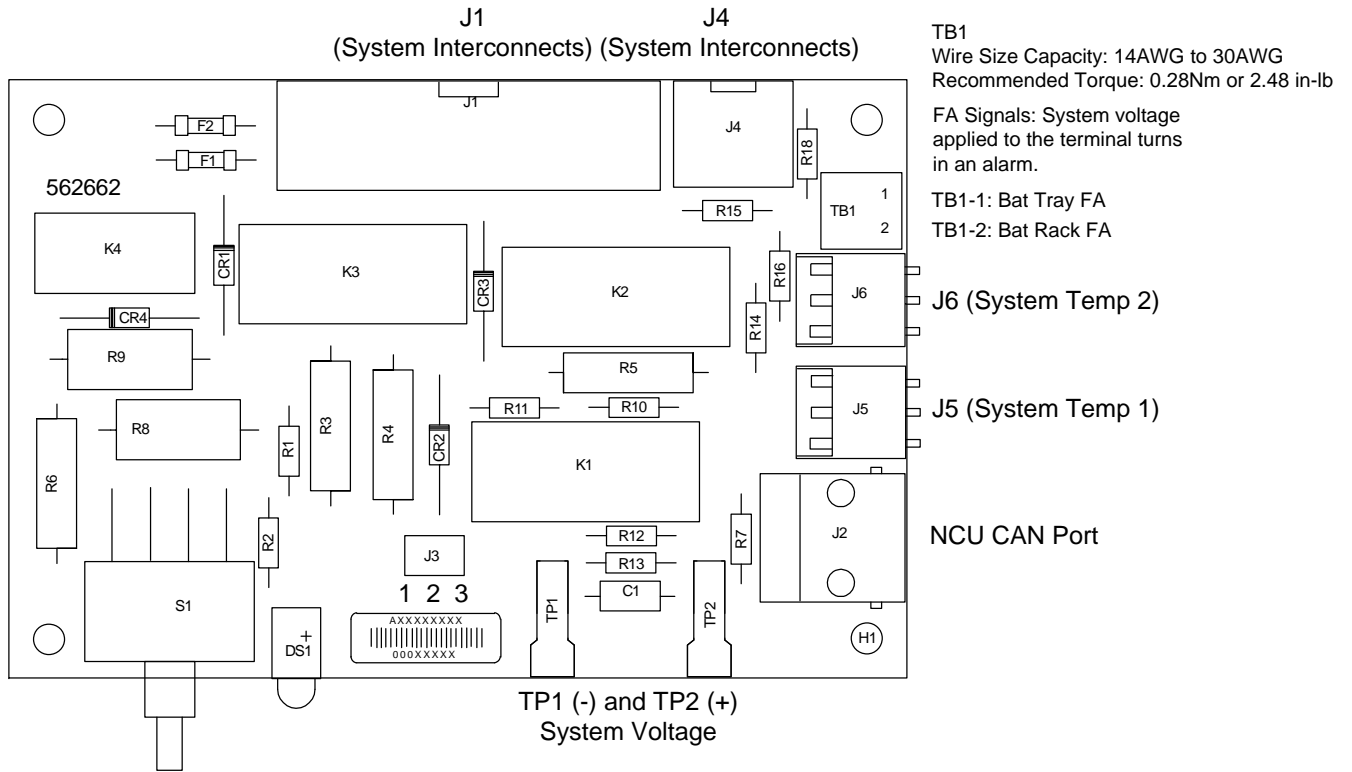

J3
Selects to power Controller from “Battery Power” or not if the battery disconnect contactor opens.

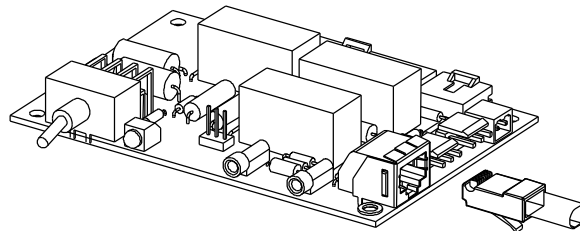
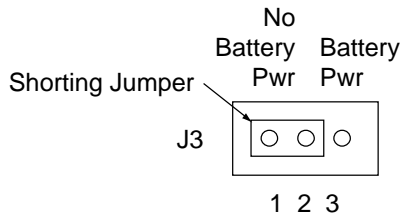

CAN termination plug P/N 548398 must be installed if an external device is not connected to the system.

IB2 (Controller Interface Board) and Optional EIB (Controller Extended Interface Board) Replacement

Refer to Figure 4.1 for circuit card location.

Procedure

1. Performing this procedure may activate external alarms. Do one of the following. If possible, disable these alarms. If these alarms cannot be easily disabled, notify the appropriate personnel to disregard any future alarms associated with this system while the procedure is being performed.



DANGER! Performing the next steps exposes service personnel to battery potential. Exercise extreme caution not to inadvertently contact or have any tool inadvertently contact any energized electrical termination.

2. Open the distribution cabinet's front door by turning the latch in the counterclockwise position.



WARNING! Damage to the circuit card may result if the next step is not followed.

3. Connect an approved grounding strap to your wrist. Attach the other end to a suitable ground.
4. Remove the shield to access the circuit cards at the bottom of the distribution cabinet.
5. Carefully label the wires connected to the customer connection terminal blocks on the circuit card. These wires must be connected to the same terminals on the replacement circuit card. Refer to Figure 6.5 or Figure 6.6.
6. Carefully label the connectors plugged into the circuit card. These connectors must be plugged into the same connectors on the replacement circuit card. Refer to Figure 6.5 or Figure 6.6.



DANGER! In the next step, external alarm wiring may be energized from an external source. DO NOT allow bare wire ends to contact any grounded or energized object.

7. Remove the external wiring from the customer connection terminal blocks. DO NOT allow the bare wire end to contact any grounded or energized object. Isolate the wire end with electrical tape. Repeat for each wire to be removed.
8. Unplug all connectors plugged into the circuit card.
9. Remove the screws securing the circuit card and remove the circuit card from the distribution cabinet.
10. In this step, ensure you do not intermix the old and replacement circuit cards. Set the switch on the replacement circuit card to the same setting as the old circuit card. Switch settings are documented in the "Setting Jumpers and Switch Options" section of the Power System Installation Instructions (IM582127000100).
11. Slide the replacement circuit card into the mounting position inside the distribution cabinet, and secure with the screws removed from the old circuit card.
12. Plug all connectors removed from the old circuit card into the same position on the replacement circuit card.



DANGER! In the next step, external alarm wiring may be energized from an external source. DO NOT allow bare wire ends to contact any grounded or energized object.

13. Reconnect the external wiring to the correct terminals on the customer connection terminal block. First remove the electrical tape that was applied to the bare wire end in a previous step. DO NOT allow the bare wire end to contact any grounded or energized object. After securing the wire, gently tug on the wire to ensure that it cannot be pulled out of the terminal block. Repeat for each wire to be reconnected.
14. Remove the grounding wrist strap.
15. Close the distribution cabinet's front door. Turn the latch clockwise to secure the door.
16. Reboot the Controller
Local Menu Navigation: At the Main Screen, press ENT and ESC at the same time to reset the NCU Controller.
Web Menu Navigation: Go to Advance Settings Menu / SW Maintenance Tab / Reboot Controller button.
17. Enable the external alarms, or notify appropriate personnel that this procedure is finished.

18. Ensure that there are no local or remote alarms active on the system.

Figure 6.5 IB2 (Controller Interface Board) Connector Locations

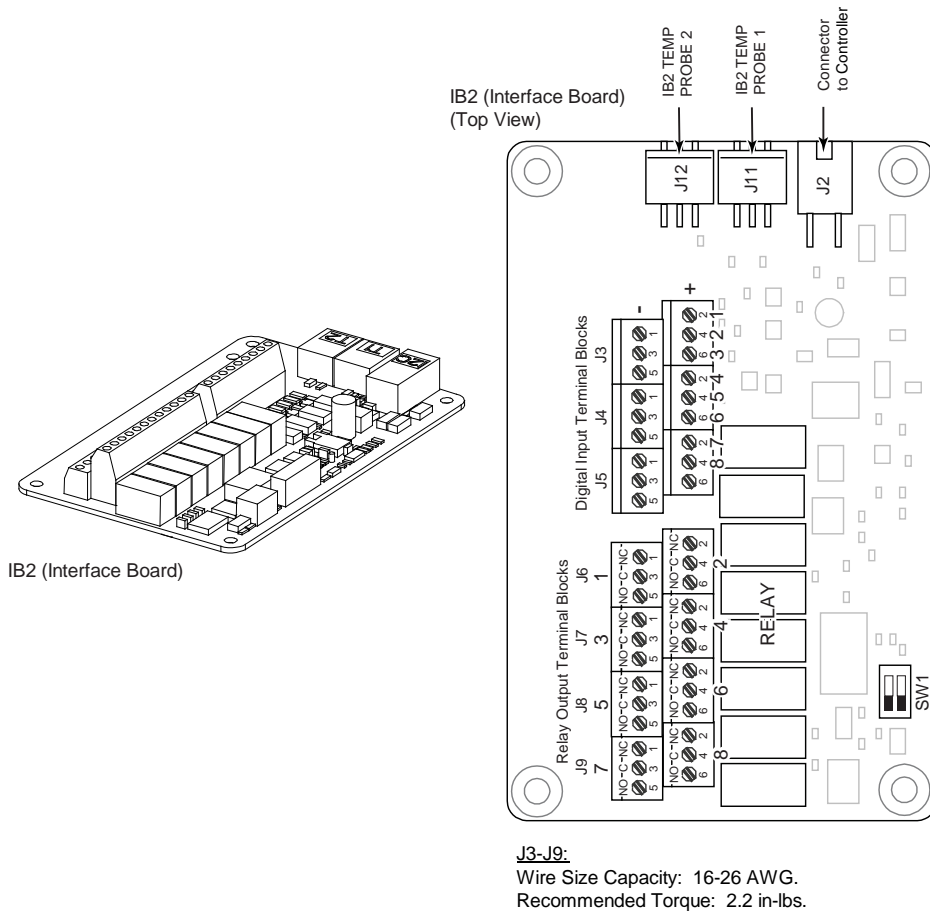
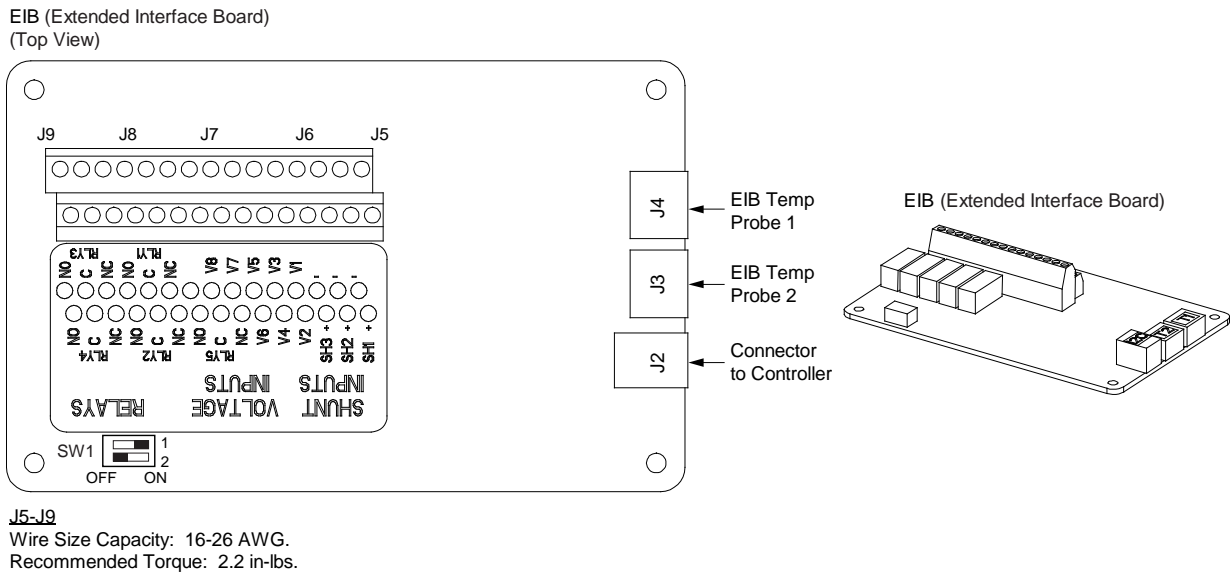

Figure 6.6 Optional EIB (Controller Extended Interface Board) Connector Locations



6.6.6 Replacing a Battery Disconnect Contactor



DANGER! All sources of AC and DC power must be completely disconnected from this power system before performing this procedure. Use a voltmeter to verify no DC voltage is present on the system busbars before proceeding.



NOTE! In the following procedure, before making busbar-to-busbar connections, apply a thin coating of electrical anti-oxidizing compound to the mating surfaces of the busbars.

Procedure



NOTE! Refer to Figure 6.7 as this procedure is performed.

Removing the Contactor

1. Verify all AC and DC power sources are disconnected from the power system.
2. Remove the distribution cabinet's rear access panel.
3. Disconnect the wiring to the contactor by unplugging the quick disconnects.
4. Note the orientation of the contactor to ensure the replacement is installed the same way. Unbolt the contactor (4-places) and remove. Save all hardware.

Installing the Replacement Contactor

1. Position the replacement contactor oriented the same way as the old.
2. Secure the contactor with the hardware removed above. Refer to Figure 6.7 for hardware build-up and recommended torque.
3. Replace the wiring to the contactor by plugging-in the quick disconnects. Refer to Figure 6.7.
4. Replace the distribution cabinet's rear access panel.

Restarting the Power System

1. Reconnect the AC and DC power sources to the power system.
2. Start the power system. Refer to the separate *Installation Instructions* (IM582127000100) for a startup procedure.
3. Verify no alarms are active.

Figure 6.7 Replacing the Battery Disconnect Contactor in the Distribution Cabinet

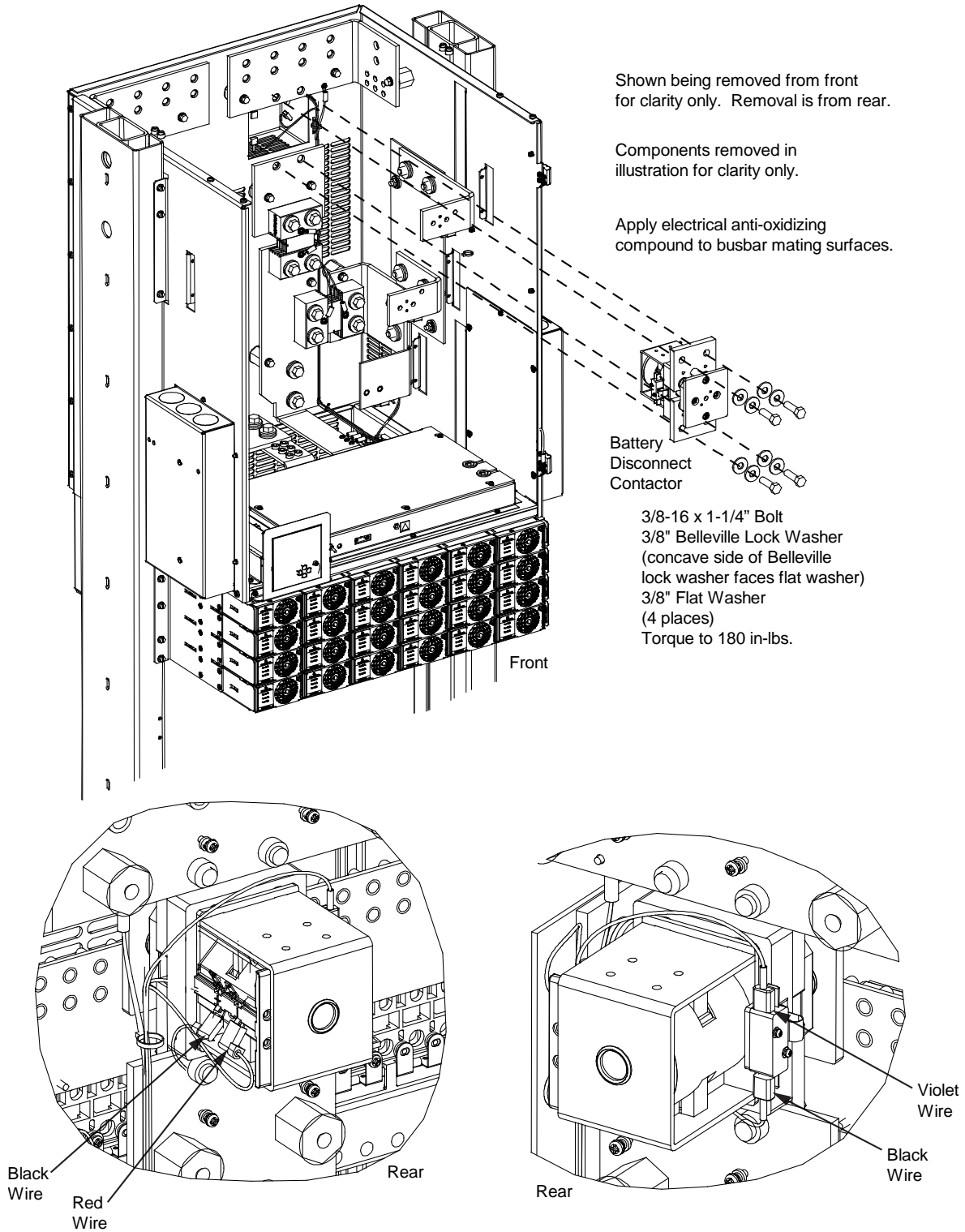

6.6.7 Replacing an SPD (Surge Protection Device) (if furnished)

The power system may be equipped with either one (1) or two (2) SPD (Surge Protection Device) assemblies mounted on the underneath side of the distribution cabinet top cover panel. Refer to “SPD Replacement for Power Systems with Two (2) SPD Assemblies Per Output Voltage Circuit” for systems equipped with two (2) SPD assemblies per output voltage circuit. Refer to “SPD Replacement for Power Systems with One (1) SPD Assembly Per Output Voltage Circuit” for systems equipped with only one (1) SPD assembly per output voltage circuit. Each SPD (Surge Protection Device) assembly consists of a mounting base and either two (2) or four (4) plug-in SPD modules. The individual SPD plug-in modules can be replaced, as well as the entire base assembly.

SPD Replacement for Power Systems with Two (2) SPD Assemblies Per Output Voltage Circuit

For systems equipped with two (2) SPD assemblies per output voltage circuit, each SPD assembly consists of a mounting base and two (2) plug-in SPD modules. Refer to Figure 6.8 and Figure 6.9. The individual SPD plug-in modules can be replaced, as well as the entire base assembly.

SPD Plug-In Module (P/N 10035033) Replacement

Perform the following steps to replace an SPD plug-in module. It is recommended to replace both SPD plug-in modules connected to the same point/polarity, even if only one shows a fault. Refer to Figure 6.8 and Figure 6.9 as this procedure is performed.

Procedure

1. Check the status indicators on the SPD plug-in modules. If the color of a status indicator has changed from green to red, then that SPD plug-in module is damaged.
2. Locate and turn OFF the circuit breaker connected to the SPD assembly being replaced.
 - 582127000 List 100, 101, 102, 103, 203 typically located in Row 2 of the power system distribution cabinet (-48 VDC bus).
 - 582127000 List 500, 501, 502, 503 typically located in Row 2 of the power system distribution cabinet (-48 VDC bus) and in Row 3 of the power system distribution cabinet (-58 VDC bus).
3. Locate the defective SPD plug-in module.
4. Using a small flat-blade screwdriver, pop-out the defective SPD plug-in module from the mounting base. See Figure 6.8 or Figure 6.9.
5. Orient the replacement SPD plug-in module over its mounting position and press it into place. See Figure 6.8 or Figure 6.9.
6. Repeat the above steps for any other SPD plug-in module being replaced.
7. Locate and turn ON the circuit breaker connected to the SPD assembly.
 - 582127000 List 100, 101, 102, 103, 203 typically located in Row 2 of the power system distribution cabinet (-48 VDC bus).
 - 582127000 List 500, 501, 502, 503 typically located in Row 2 of the power system distribution cabinet (-48 VDC bus) and in Row 3 of the power system distribution cabinet (-58 VDC bus).
8. Verify there are no alarms being generated by the system.

SPD Base with Plug-In Modules (P/N 10034885) Replacement

Check SPD mounting base. If the mounting base is damaged, then replace the complete SPD assembly (mounting base and plug-in modules). Refer to Figure 6.8 and Figure 6.9 as this procedure is performed.

Procedure

1. Locate the defective SPD assembly.
2. Locate and turn OFF the circuit breaker connected to the SPD assembly to be replaced.
 - 582127000 List 100, 101, 102, 103, 203 typically located in Row 2 of the power system distribution cabinet (-48 VDC bus).
 - 582127000 List 500, 501, 502, 503 typically located in Row 2 of the power system distribution cabinet (-48 VDC bus) and in Row 3 of the power system distribution cabinet (-58 VDC bus).
3. If not already done, label the power cables (“+”, “-”, and “earth ground”) connected to the defective SPD assembly.
4. Disconnect the power cables from the “+”, “-”, and “earth ground” terminals of the defective SPD assembly.
5. Remove the 3-position alarm terminal block half from the defective SPD assembly. Do not remove the wires from the 3-position alarm terminal block.
6. Using a small flat-blade screwdriver, slide the clip securing the defective SPD assembly to the DIN rail. Remove the defective SPD assembly from the DIN rail.
7. Remove the 3-position alarm terminal block half from the replacement SPD assembly. This will not be used and may be saved.
8. Orient the replacement SPD assembly on the DIN rail by sliding the fix end into the DIN rail. Using a small flat-blade screwdriver, slide the clip on the other end of the SPD assembly and snap the SPD assembly to the DIN rail.
9. Reinsert the existing alarm wiring 3-position terminal block into the replacement SPD assembly.
10. Reconnect the power cables (“+”, “-”, and “earth ground”) (with wire end ferrules) to the replacement SPD assembly. The recommended torque is 30 in-lbs.
11. Locate and turn ON the circuit breaker connected to the SPD assembly.
 - 582127000 List 100, 101, 102, 103, 203 typically located in Row 2 of the power system distribution cabinet (-48 VDC bus).
 - 582127000 List 500, 501, 502, 503 typically located in Row 2 of the power system distribution cabinet (-48 VDC bus) and in Row 3 of the power system distribution cabinet (-58 VDC bus).
12. Verify there are no alarms being generated by the system.

**Figure 6.8 SPD Replacement (P/N 10035033 Plug-In Module or P/N 10034885 Mounting Base and Plug-In Modules)
(582127000100, 582127000101, 582127000102, 582127000103, and 582127000203)**

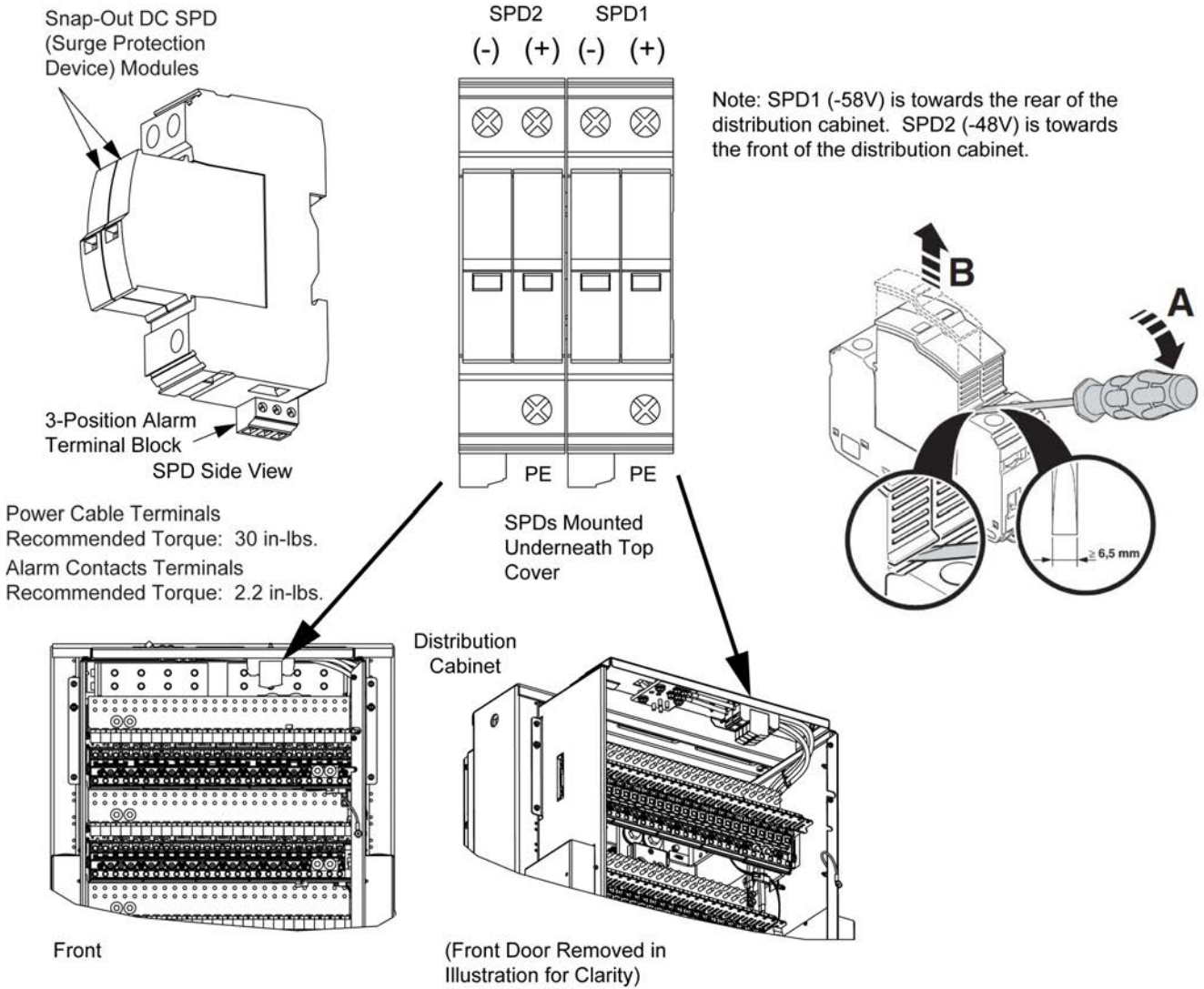

**Figure 6.9 SPD Replacement (P/N 10035033 Plug-In Module or P/N 10034885 Mounting Base and Plug-In Modules)
(582127000500, 582127000501, 582127000502, and 582127000503)**

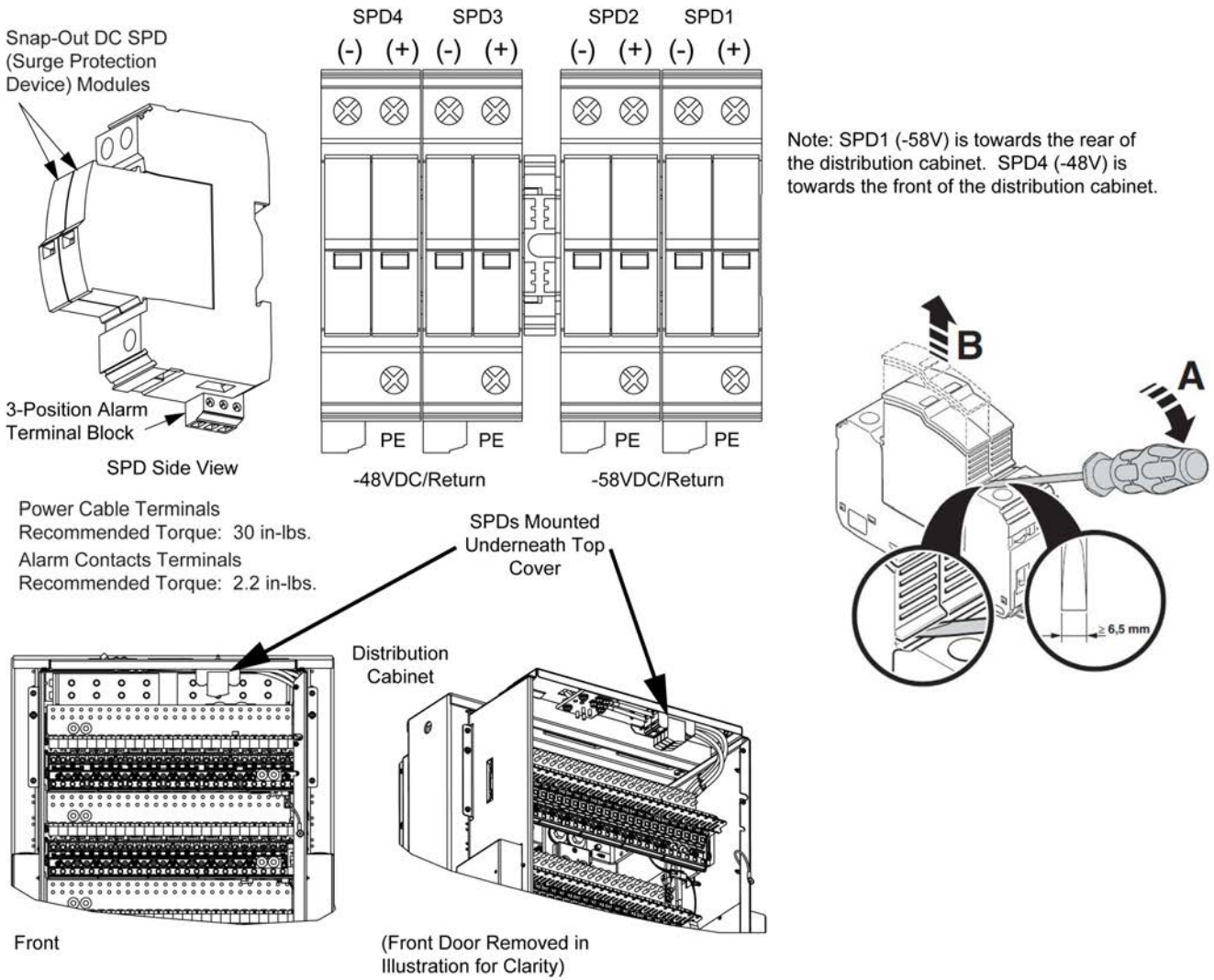

SPD Replacement for Power Systems with One (1) SPD Assembly Per Output Voltage Circuit

For systems equipped with one (1) SPD assembly per output voltage circuit, each SPD assembly consists of a mounting base and either two (2) plug-in SPD modules for Bourns SPDs or four (4) plug-in SPD modules for Phoenix Contact SPDs. Refer to Figure 6.10 and Figure 6.11 for the Phoenix Contact version. Refer to Figure 6.12 and Figure 6.13 for the Bourns version. The individual SPD plug-in modules can be replaced, as well as the entire base assembly.

SPD Plug-In Module - Phoenix Contact Version (P/N 10035033) Replacement

Perform the following steps to replace an SPD plug-in module. It is recommended to replace both SPD plug-in modules connected to the same point/polarity, even if only one shows a fault. Refer to Figure 6.10 and Figure 6.11 as this procedure is performed.

Procedure

1. Check the status indicators on the SPD plug-in modules. If the color of a status indicator has changed from green to red, then that SPD plug-in module is damaged.
2. Locate and turn OFF the circuit breaker connected to the SPD assembly being replaced.
 - 582127000 List 100, 101, 102, 103, 203 typically located in Row 2 of the power system distribution cabinet (-48 VDC bus).
 - 582127000 List 500, 501, 502, 503 typically located in Row 2 of the power system distribution cabinet (-48 VDC bus) and in Row 3 of the power system distribution cabinet (-58 VDC bus).
3. Locate the defective SPD plug-in module.
4. Using a small flat-blade screwdriver, pop-out the defective SPD plug-in module from the mounting base. See Figure 6.10 or Figure 6.11.
5. Orient the replacement SPD plug-in module over its mounting position and press it into place. See Figure 6.10 or Figure 6.11.
6. Repeat the above steps for any other SPD plug-in module being replaced.
7. Locate and turn ON the circuit breaker connected to the SPD assembly.
 - 582127000 List 100, 101, 102, 103, 203 typically located in Row 2 of the power system distribution cabinet (-48 VDC bus).
 - 582127000 List 500, 501, 502, 503 typically located in Row 2 of the power system distribution cabinet (-48 VDC bus) and in Row 3 of the power system distribution cabinet (-58 VDC bus).
8. Verify there are no alarms being generated by the system.

SPD Base with Plug-In Modules – Phoenix Contact Version (P/N 10060979) Replacement

Check SPD mounting base. If the mounting base is damaged, then replace the complete SPD assembly (mounting base and plug-in modules). Refer to Figure 6.10 and Figure 6.11 as this procedure is performed.

Procedure

1. Locate the defective SPD assembly.
2. Locate and turn OFF the circuit breaker connected to the SPD assembly to be replaced.
 - 582127000 List 100, 101, 102, 103, 203 typically located in Row 2 of the power system distribution cabinet (-48 VDC bus).
 - 582127000 List 500, 501, 502, 503 typically located in Row 2 of the power system distribution cabinet (-48 VDC bus) and in Row 3 of the power system distribution cabinet (-58 VDC bus).
3. If not already done, label the power cables (“+”, “-”, and “earth ground”) connected to the defective SPD assembly.
4. Disconnect the power cables from the “+”, “-”, and “earth ground” terminals of the defective SPD assembly.
5. Remove the 3-position alarm terminal block half from the defective SPD assembly. Do not remove the wires from the 3-position alarm terminal block.
6. Using a small flat-blade screwdriver, slide the clip securing the defective SPD assembly to the DIN rail. Remove the defective SPD assembly from the DIN rail.
7. Remove the 3-position alarm terminal block half from the replacement SPD assembly. This will not be used and may be saved.
8. Orient the replacement SPD assembly on the DIN rail by sliding the fix end into the DIN rail. Using a small flat-blade screwdriver, slide the clip on the other end of the SPD assembly and snap the SPD assembly to the DIN rail.
9. Reinsert the existing alarm wiring 3-position terminal block into the replacement SPD assembly.
10. Reconnect the power cables (“+”, “-”, and “earth ground”) (with wire end ferrules) to the replacement SPD assembly. The recommended torque is 30 in-lbs.
11. Locate and turn ON the circuit breaker connected to the SPD assembly.
 - 582127000 List 100, 101, 102, 103, 203 typically located in Row 2 of the power system distribution cabinet (-48 VDC bus).
 - 582127000 List 500, 501, 502, 503 typically located in Row 2 of the power system distribution cabinet (-48 VDC bus) and in Row 3 of the power system distribution cabinet (-58 VDC bus).
12. Verify there are no alarms being generated by the system.

Figure 6.10 SPD Replacement – Phoenix Contact Version (P/N 10035033 Plug-In Module or P/N 10060979 Mounting Base and Plug-In Modules) (582127000100, 582127000101, 582127000102, 582127000103, and 582127000203)

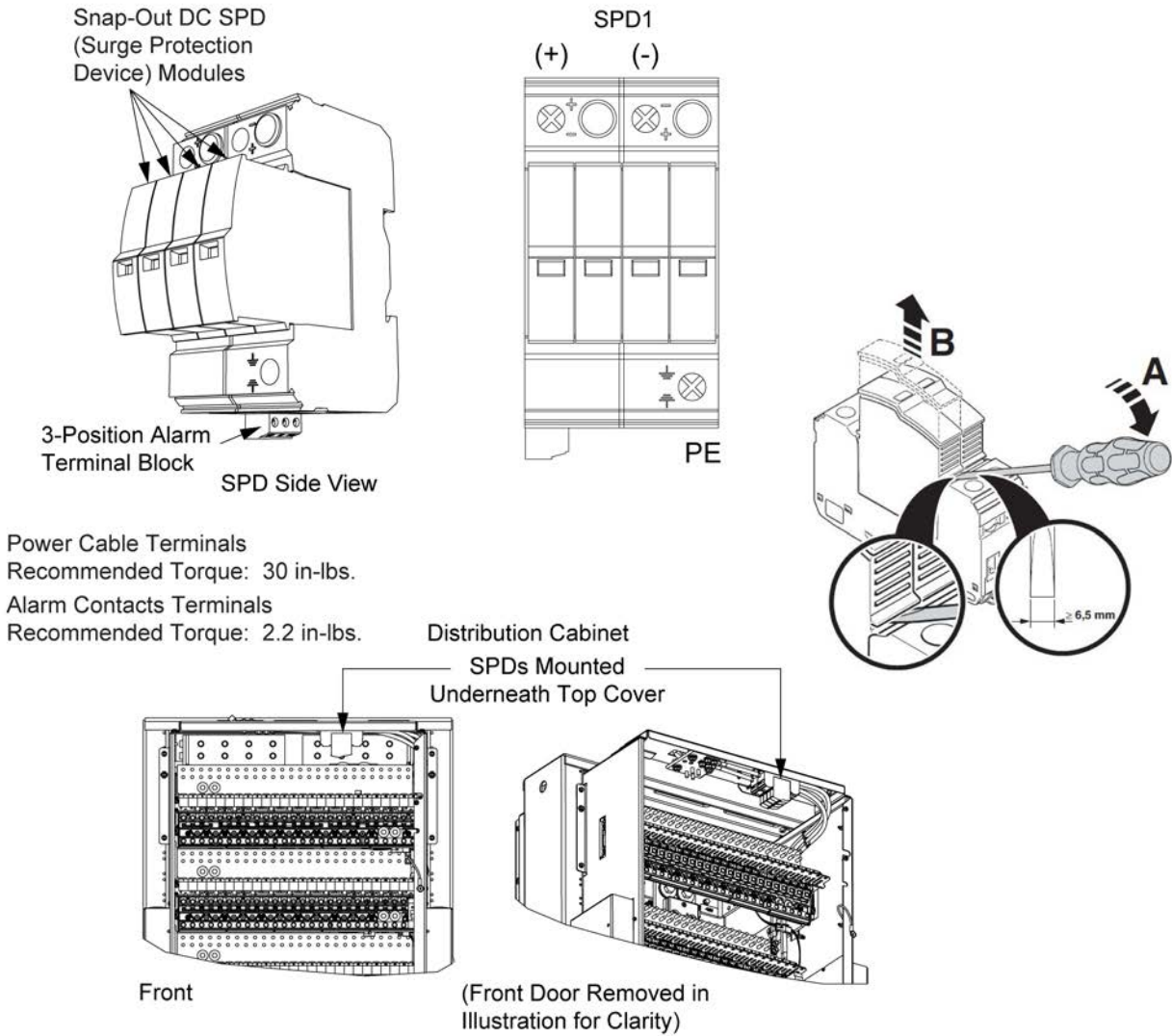
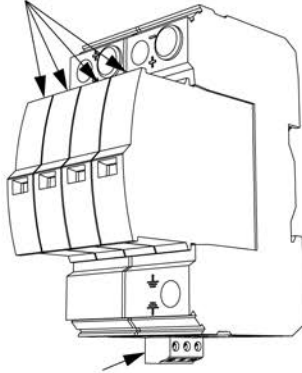

Figure 6.11 SPD Replacement – Phoenix Contact Version (P/N 10035033 Plug-In Module or P/N 10060979 Mounting Base and Plug-In Modules) (582127000500, 582127000501, 582127000502, and 582127000503)

Snap-Out DC SPD
(Surge Protection
Device) Modules



3-Position Alarm
Terminal Block

SPD Side View

Power Cable Terminals
Recommended Torque: 30 in-lbs.
Alarm Contacts Terminals
Recommended Torque: 2.2 in-lbs.

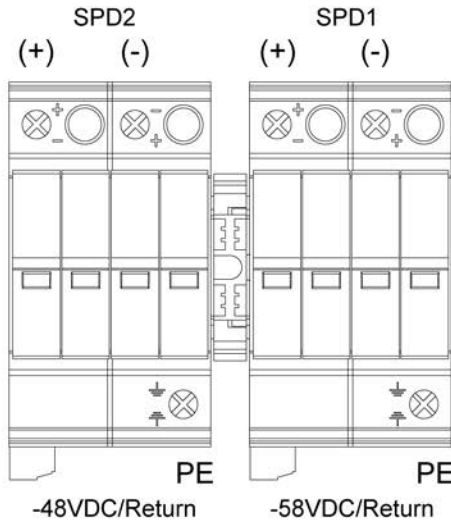

Note: SPD1 (-58V) is towards the rear of the distribution cabinet. SPD2 (-48V) is towards the front of the distribution cabinet.

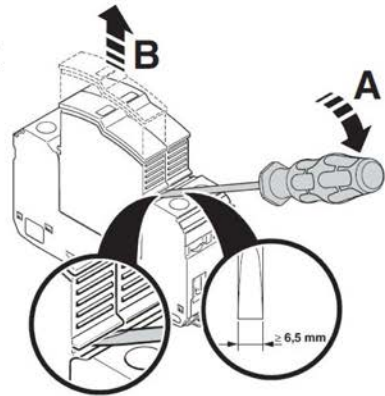

Distribution Cabinet
SPDs Mounted
Underneath Top Cover

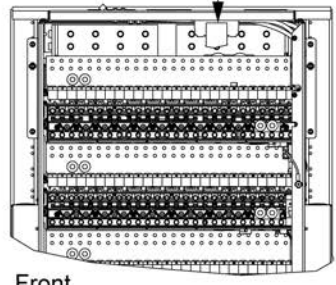

Front

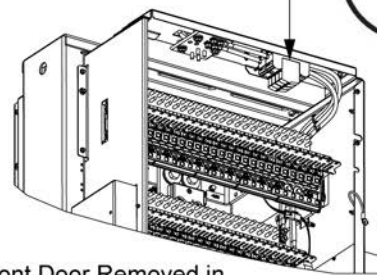

(Front Door Removed in
Illustration for Clarity)

SPD Plug-In Module – Bourns Version (P/N 10071911) Replacement

Perform the following steps to replace an SPD plug-in module. It is recommended to replace both SPD plug-in modules connected to the same point/polarity, even if only one shows a fault. Refer to Figure 6.12 and Figure 6.13 as this procedure is performed.

Procedure

1. Check the status indicators on the SPD plug-in modules. If the color of a status indicator has changed from green to red, then that SPD plug-in module is damaged.
2. Locate and turn OFF the circuit breaker connected to the SPD assembly being replaced.
 - 582127000 List 100, 101, 102, 103, 203 typically located in Row 2 of the power system distribution cabinet (-48 VDC bus).
 - 582127000 List 500, 501, 502, 503 typically located in Row 2 of the power system distribution cabinet (-48 VDC bus) and in Row 3 of the power system distribution cabinet (-58 VDC bus).
3. Locate the defective SPD plug-in module.
4. Using a small flat-blade screwdriver, pop-out the defective SPD plug-in module from the mounting base. See Figure 6.12 or Figure 6.13.
5. Orient the replacement SPD plug-in module over its mounting position and press it into place. See Figure 6.12 or Figure 6.13.
6. Repeat the above steps for any other SPD plug-in module being replaced.
7. Locate and turn ON the circuit breaker connected to the SPD assembly.
 - 582127000 List 100, 101, 102, 103, 203 typically located in Row 2 of the power system distribution cabinet (-48 VDC bus).
 - 582127000 List 500, 501, 502, 503 typically located in Row 2 of the power system distribution cabinet (-48 VDC bus) and in Row 3 of the power system distribution cabinet (-58 VDC bus).
8. Verify there are no alarms being generated by the system.

SPD Base with Plug-In Modules – Bourns Version (P/N 10060979) Replacement

Check SPD mounting base. If the mounting base is damaged, then replace the complete SPD assembly (mounting base and plug-in modules). Refer to Figure 6.12 and Figure 6.13 as this procedure is performed.

Procedure

1. Locate the defective SPD assembly.
2. Locate and turn OFF the circuit breaker connected to the SPD assembly to be replaced.
 - 582127000 List 100, 101, 102, 103, 203 typically located in Row 2 of the power system distribution cabinet (-48 VDC bus).
 - 582127000 List 500, 501, 502, 503 typically located in Row 2 of the power system distribution cabinet (-48 VDC bus) and in Row 3 of the power system distribution cabinet (-58 VDC bus).
3. If not already done, label the power cables (“+”, “-”, and “earth ground”) connected to the defective SPD assembly.
4. Disconnect the power cables from the “+”, “-”, and “earth ground” terminals of the defective SPD assembly.
5. Remove the 3-position alarm terminal block half from the defective SPD assembly. Do not remove the wires from the 3-position alarm terminal block.
6. Using a small flat-blade screwdriver, slide the clip securing the defective SPD assembly to the DIN rail. Remove the defective SPD assembly from the DIN rail.
7. Remove the 3-position alarm terminal block half from the replacement SPD assembly. This will not be used and may be saved.
8. Orient the replacement SPD assembly on the DIN rail by sliding the fix end into the DIN rail. Using a small flat-blade screwdriver, slide the clip on the other end of the SPD assembly and snap the SPD assembly to the DIN rail.
9. Reinsert the existing alarm wiring 3-position terminal block into the replacement SPD assembly.
10. Reconnect the power cables (“+”, “-”, and “earth ground”) (with wire end ferrules) to the replacement SPD assembly. The recommended torque is 30 in-lbs.
11. Locate and turn ON the circuit breaker connected to the SPD assembly.
 - 582127000 List 100, 101, 102, 103, 203 typically located in Row 2 of the power system distribution cabinet (-48 VDC bus).
 - 582127000 List 500, 501, 502, 503 typically located in Row 2 of the power system distribution cabinet (-48 VDC bus) and in Row 3 of the power system distribution cabinet (-58 VDC bus).
12. Verify there are no alarms being generated by the system.

Figure 6.12 SPD Replacement – Bourns Version (P/N 10071911 Plug-In Module or P/N 10060979 Mounting Base and Plug-In Modules) (582127000100, 582127000101, 582127000102, 582127000103, and 582127000203)

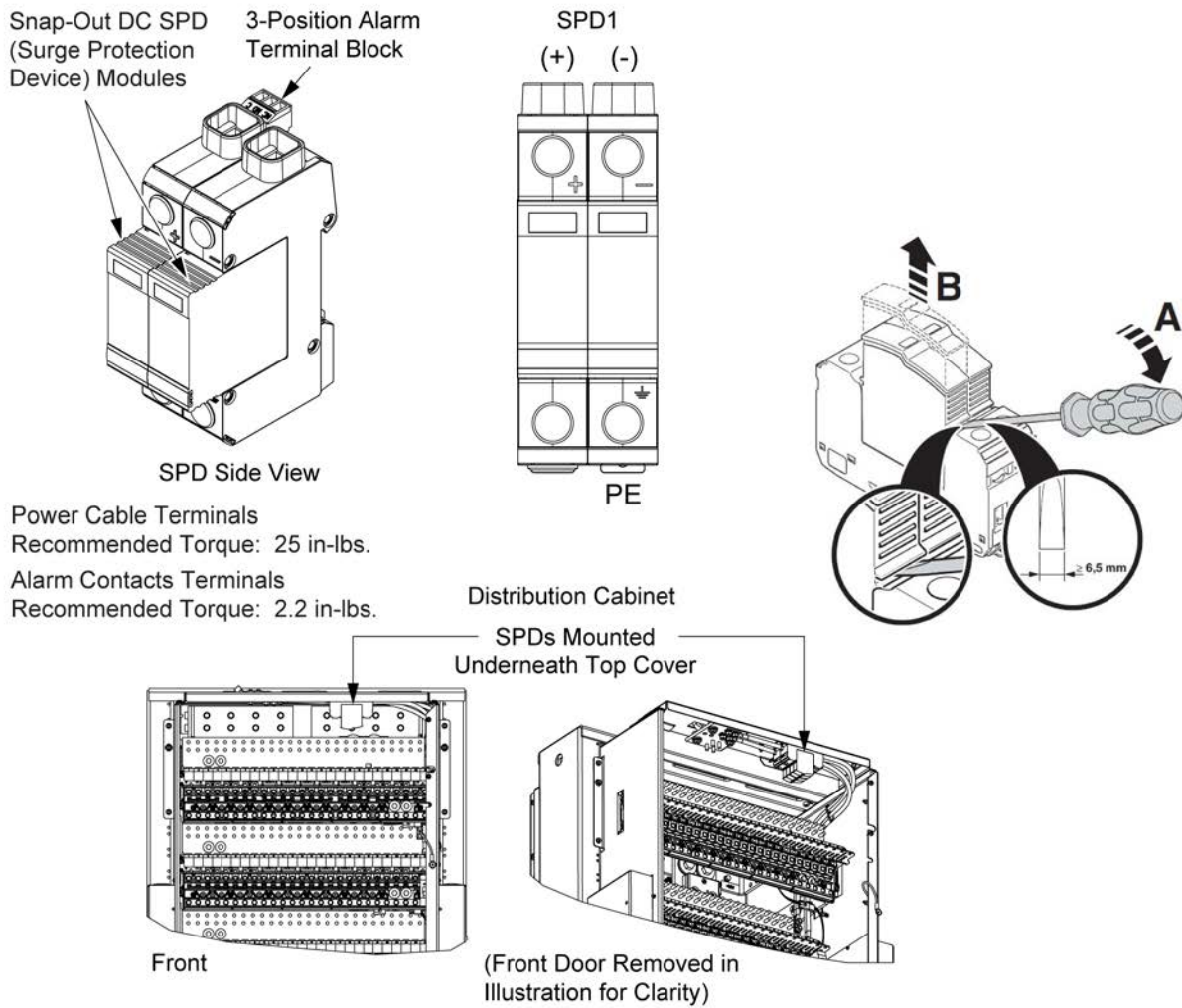
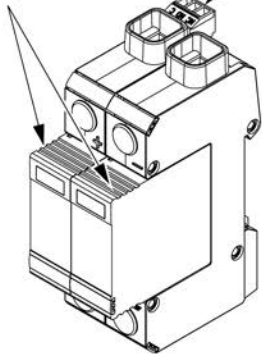
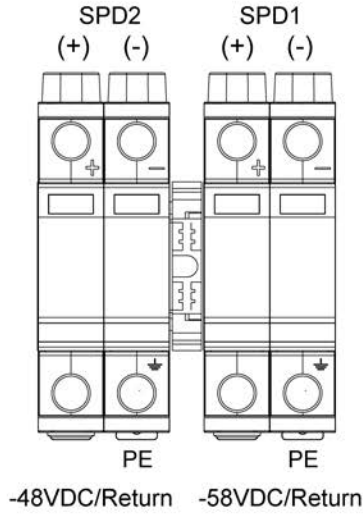

Figure 6.13 SPD Replacement – Bourns Version (P/N 10071911 Plug-In Module or P/N 10060979 Mounting Base and Plug-In Modules) (582127000500, 582127000501, 582127000502, and 582127000503)

Snap-Out DC SPD (Surge Protection Device) Modules
3-Position Alarm Terminal Block



SPD Side View



Note: SPD1 (-58V) is towards the rear of the distribution cabinet.
SPD2 (-48V) is towards the front of the distribution cabinet.

Power Cable Terminals
Recommended Torque: 25 in-lbs.
Alarm Contacts Terminals
Recommended Torque: 2.2 in-lbs.

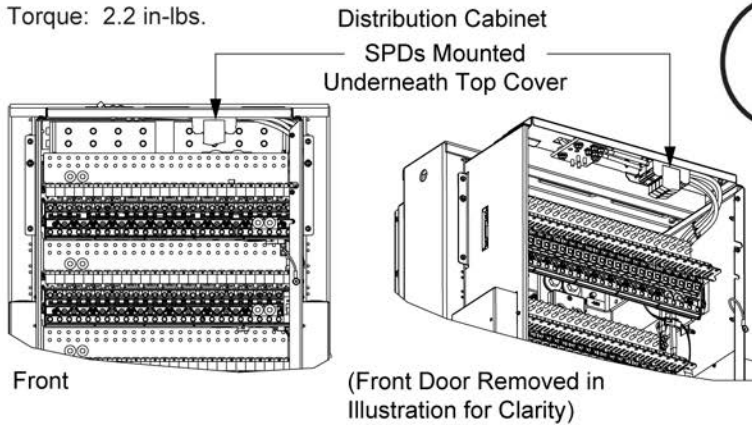
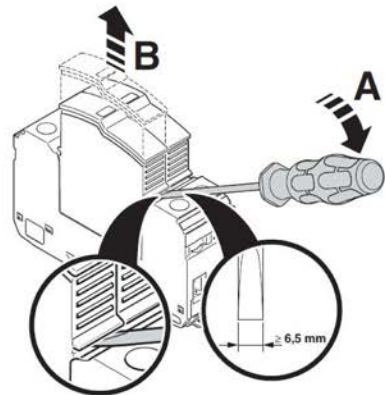

Front

(Front Door Removed in Illustration for Clarity)

Connect with Vertiv on Social Media



<https://www.facebook.com/vertiv/>



<https://www.instagram.com/vertiv/>



<https://www.linkedin.com/company/vertiv/>



<https://www.x.com/vertiv/>



Vertiv.com | Vertiv Headquarters, 505 N Cleveland Ave, Westerville, OH 43082, USA

© 2026 Vertiv Group Corp. All rights reserved. Vertiv™ and the Vertiv logo are trademarks or registered trademarks of Vertiv Group Corp. All other names and logos referred to are trade names, trademarks or registered trademarks of their respective owners. While every precaution has been taken to ensure accuracy and completeness here, Vertiv Group Corp. assumes no responsibility, and disclaims all liability, for damages resulting from use of this information or for any errors or omissions.