

Handling Instructions Guide for MMI12, MMI24, MMI36, MMI48, MMI60 and MMI96

NOTE: Reference guide for receiving, unpacking and preparing for installation. DO NOT THROW AWAY!

Safety Information

WARNING

Risk of unit falling over. Improper handling can cause equipment damage, injury, or death. Read all following instructions before attempting to move, lift, remove packaging from, or preparing unit for installation.

CAUTION

Risk of contact with sharp edges, splinters, and exposed fasteners. Can cause injury. Wear appropriate OSHA approved personal protective equipment (PPE) when attempting to move, lift, remove packaging from, or prepare unit for installation.

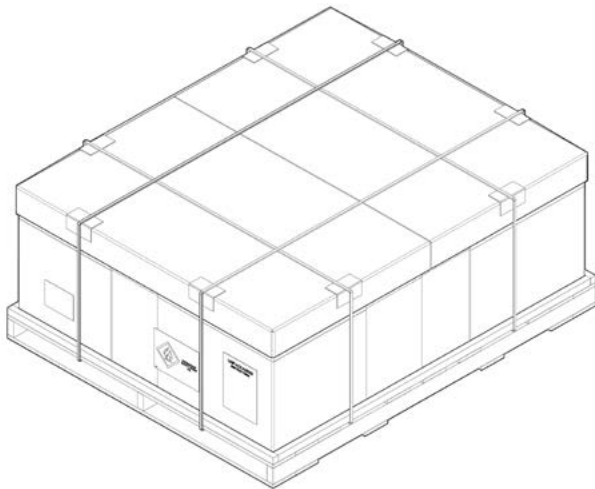

NOTICE

Risk of overhead interference. Can cause unit and structure damage. Unit may be too wide to fit through a doorway while on or off pallet. Measure unit and doorway widths, and refer to installation plans prior to moving unit for clearance verification.

NOTICE

Risk of unit damage if improperly stored. Keep unit vertically upright, indoors, and protected from dampness, freezing temperatures, and contact damage.

Vertiv™ CoolPhase Ceiling Unit Weights

Model		Product Weights lb (kg)	
		Net Weight	Shipping Weight
MMI12 (1 Ton)	Minimum (DX only)	232 (106)	387 (176)
	Maximum (DX + FC)	266 (121)	421 (191)
MMI24/36 (2 & 3 Ton)	Minimum (DX only)	267 (121)	422 (191)
	Maximum (DX + FC)	308 (140)	463 (210)
MMI48/60 (4 & 6 Ton)	Minimum (DX only)	411 (187)	618 (281)
	Maximum (DX + FC)	493 (224)	700 (318)
MMI96 (8 Ton)	Minimum (DX only)	611 (277)	836 (379)
	Maximum (DX + FC)	682 (309)	906 (411)

Equipment Inspection

Upon arrival verify that labeled equipment matches Bill of Lading. Carefully inspect all items for either visible or concealed damage. Damage should be immediately reported to carrier and a damage claim filed with a copy sent to Vertiv or to your sales representative.

Packing Material



Most materials used to package this unit is recyclable. Please save for future use, or appropriately dispose of material.

Handling the Unit While Packaged

Transport packaged unit using a fork lift or pallet jack.

- When using a fork lift or pallet jack, make sure forks (if adjustable) are spread to widest allowable distance to still fit under pallet. Make sure fork length is suitable for pallet length.
- Packaged unit shall not be lifted any higher than 2 - 4 in (51 - 102 mm) off ground when handled. All by-standing personnel shall be no closer than 12 ft (3.7 m) to handled packaged unit.
- If circumstances require unit to be lifted higher than 4 in (102 mm) great care shall be exercised and all by-standing personnel are to be no closer than 20 ft (5 m) to lift point of unit.

Recommended Unit Handling Equipment

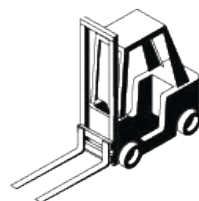

**Fork
Lift**

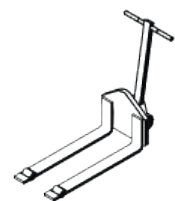

**Pallet
Jack**

Unpacking the Unit

Step 1:

Place the package on a flat surface, then cut the poly straps to release the unit from the pallet.

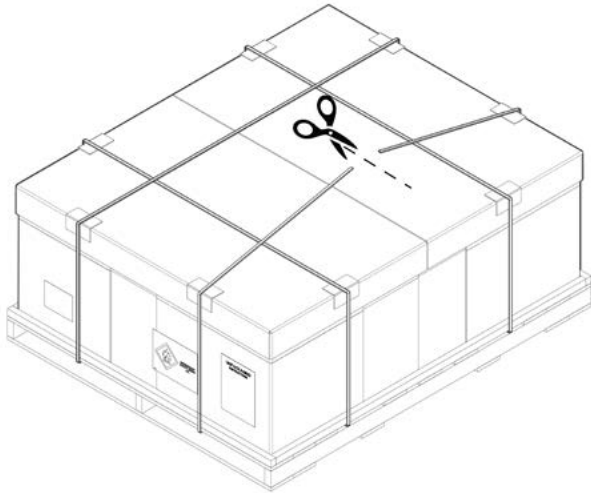

Step 2:

After releasing the poly straps, remove all cardboard protector edges and covers.

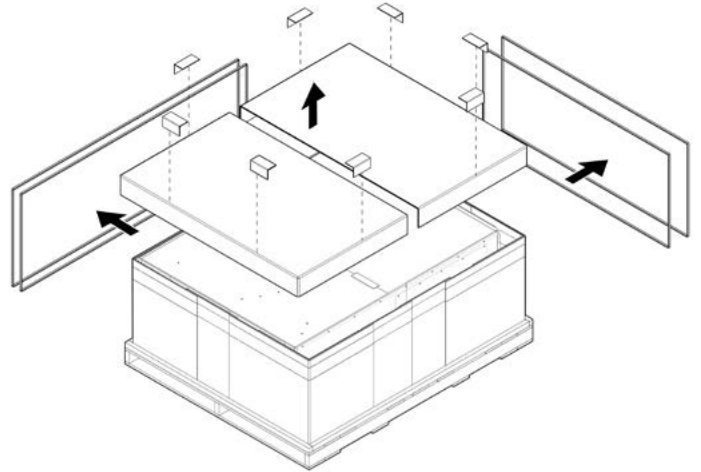

Step 3:

Remove the poly roll foil (A) then remove the corrugated pads (B).

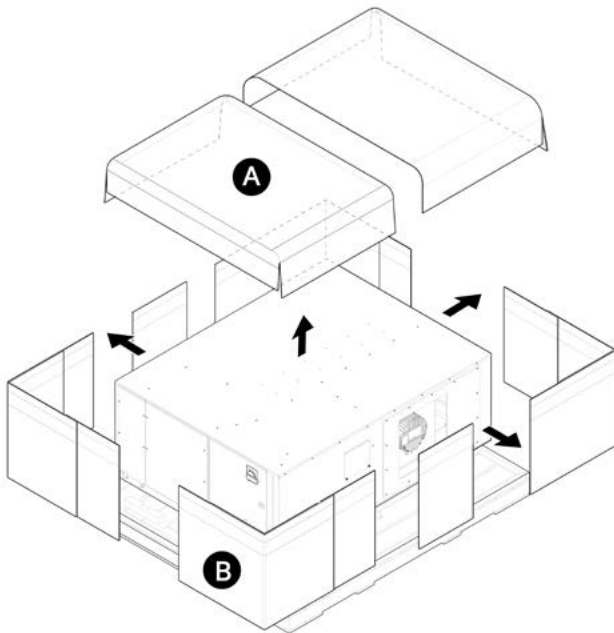

Removing Unit from Pallet

Step 4:

Remove the hex-head screws and washers, then take the unit out of the pallet.

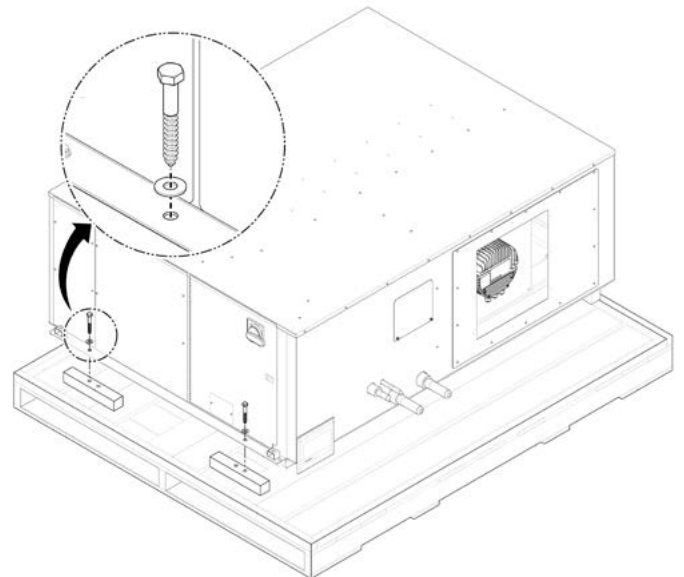

To contact Vertiv Technical Support: visit www.Vertiv.com

© 2026 Vertiv Group Corp. All rights reserved. Vertiv™ and the Vertiv logo are trademarks or registered trademarks of Vertiv Group Corp. All other names and logos referred to are trade names, trademarks or registered trademarks of their respective owners. While every precaution has been taken to ensure accuracy and completeness here, Vertiv Group Corp. assumes no responsibility, and disclaims all liability, for damages resulting from use of this information or for any errors or omissions.

