



E-book

Powering the AI era

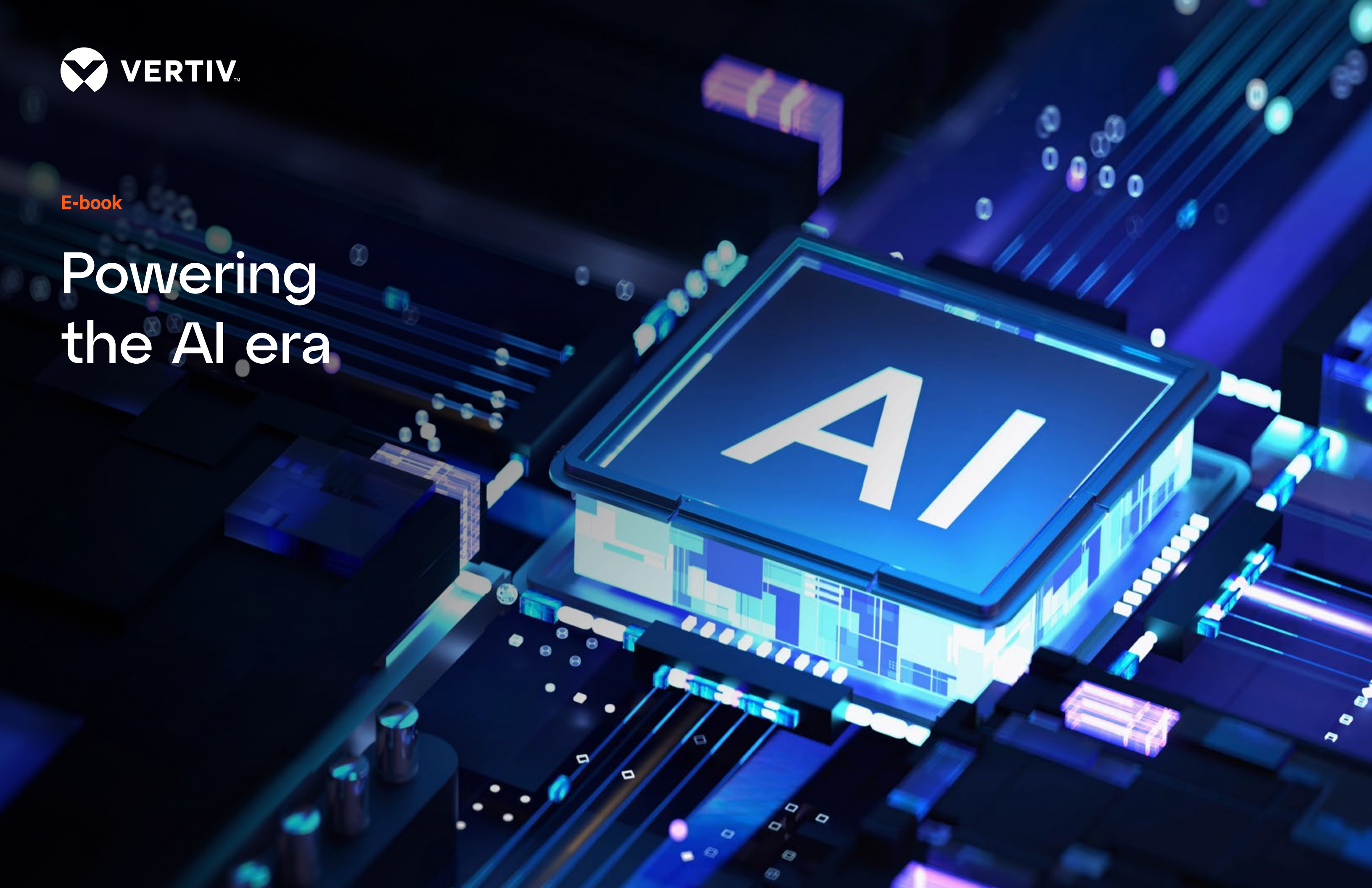



Table of contents

Introduction in the AI era.....04

Power train in the AI era.....07

Large power converters – UPS solutions for variable AI loads13

Vertiv™ Trinergy™
Vertiv™ Power UPS9000

Medium power - Reaching the edge, where agility matters most.....21

Vertiv™ Liebert® APM2 (30–600 kW)

Energy storage – Beyond backup - Intelligent energy for the AI era.....25

Vertiv™ EnergyCore, Lithium Ion Battery Cabinets
Vertiv™ Liebert® APM2 – LiB

Power solutions & distribution - Redundant power paths for continuous AI operations.....29

Vertiv™ PowerSwitch 7000 (160–630 A)
Vertiv™ Liebert® STS2 (1250–1800 A)
Vertiv™ Liebert® RXA Remote Power Panel (up to 400 A)

DCPower.....37

Vertiv™ PowerDirect In-Rack 33 kW - Compatible with Open Compute Project (OCP)w

Introduction

Artificial Intelligence is reshaping the data center landscape — creating power demands at a scale and speed never seen before.

AI workloads are expanding rapidly and introducing new operational and energy-intensive characteristics compared to traditional cloud applications.

Industry analysts observe that the acceleration of AI-optimized infrastructure is becoming a major contributor to rising global data center electricity demand. Gartner projects that overall data center power consumption will more than double by 2030, with AI-driven compute representing an increasingly significant share of this growth.

Vertiv stands at the center of this transformation — uniting decades of power expertise with next-generation technology that enables AI data centers to grow, adapt, and perform with confidence. Because in the AI era, resilience isn't optional. It's the foundation of innovation.

Resilience has long underpinned successful digital transformation. In the AI era, it becomes even more critical—serving as the backbone of reliable, scalable innovation.

Data doesn't sleep – neither should your cooling and power

Reliable, efficient, and scalable power infrastructure for the AI era — from grid to chip. AI never stops learning, analyzing, and adapting — and neither should the systems that power it.

Vertiv provides the infrastructure behind the world's most demanding AI operations, supporting performance that's always on, always efficient, and always ready for what's next.

From hyperscale to edge, Vertiv keeps the AI revolution powered — reliably, continuously and without compromise.





This e- book provides a clear and practical starting point for understanding Vertiv’s AI ready power portfolio. It brings together the essential messages, the key differentiators, and a simple navigation path to help readers explore the solutions best suited to your AI infrastructure needs.

AI workloads change everything

They create fast, unpredictable load spikes, extreme power density, and new stress on the powertrain.

Traditional power infrastructure is no longer enough

AI requires ultra fast response, higher efficiency, larger building blocks, and smarter energy storage.

Vertiv delivers the most complete AI ready power ecosystem

From large scale UPS and energy storage to distribution and in rack power, Vertiv provides a true end to end AI power platform.

Why Vertiv?

Vertiv delivers power solutions engineered to support AI-driven workloads, while also supporting the modernization of existing infrastructures to meet evolving performance requirements.

- AI trained control algorithms (Battery Shield, Input Power Smoothing) proven under real GPU load simulations.
- Higher capacity, denser, more efficient power blocks for fast deployment and higher rack density.
- A full grid to chip portfolio with no integration gaps.
- Continuous duty architectures (e.g., Vertiv™ Trinergy™ booster converter) built for extreme AI load swings.
- Digital services (Vertiv LIFE™) enabling predictive maintenance and maximum uptime.
- Vertiv is the power backbone of the AI era.

Customer needs → Vertiv Solutions

A simple, visual mapping to support fast positioning: Customer need / Problem value proposition.

Vertiv Solution

- | | |
|---|--|
| <p>1. AI load spikes & fast dynamics stable power, fewer battery cycles, grid protection:
→ Vertiv™ Trinergy™ / Vertiv™ PowerUPS 9000</p> <p>2. High rack density (50–120 kW+) more power per rack, smaller footprint:
→ Vertiv™ PowerDirect In-Rack</p> <p>3. AI scaling & modular growth build as you grow flexibility:
→ Vertiv™ Liebert® APM2</p> | <p>4. Energy storage under AI workloads fast cycles, accurate SoC/SoH, extended battery life:
→ Vertiv™ EnergyCore Lithium-ion</p> <p>5. Zero downtime distribution seamless transfer, no single point of failure:
→ Vertiv™ PowerSwitch 7000 / Vertiv™ Liebert® STS2</p> <p>6. Distributed or edge AI compact, efficient, resilient:
→ Vertiv™ Liebert® APM2, Vertiv™ Liebert® RXA, Vertiv™ PowerDirect</p> |
|---|--|

Your guided path through Vertiv™ AI power portfolio

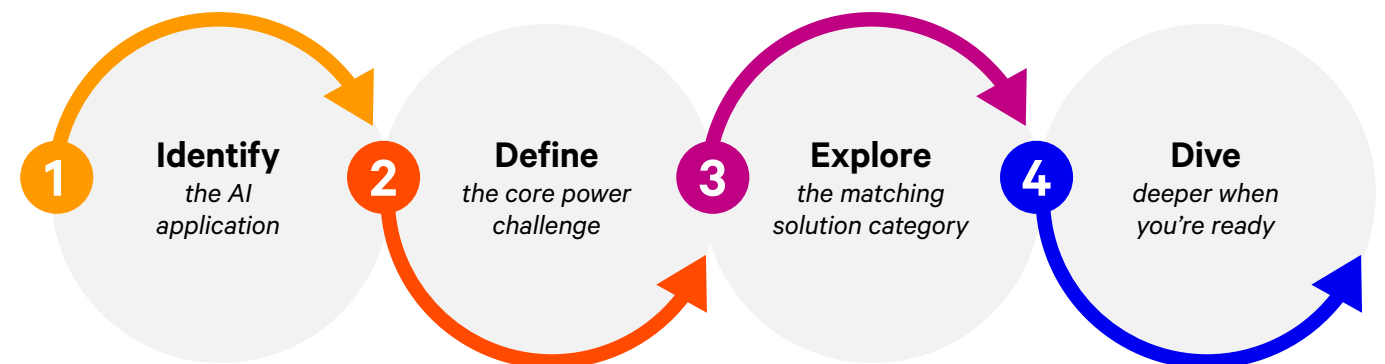

- | | | | |
|---|---|--|---|
| <ul style="list-style-type: none"> • Training • Inference • High density GPU • Colocation • Edge AI <p>Different AI architectures drive different power profiles — start by clarifying the use case.</p> | <ul style="list-style-type: none"> • Load spikes & variability • Density or space constraints • Grid limitations • Scalability & growth • Need for continuous uptime. <p>This helps narrow down the right part of the portfolio.</p> | <p>Each section of the e book maps solutions to real AI needs.</p> <ul style="list-style-type: none"> • Large scale AI UPS: Vertiv™ Trinergy™, Vertiv™ PowerUPS 9000 • Modular / Edge UPS: Vertiv™ Liebert® APM2 • Energy storage for AI: Vertiv™ EnergyCore Li ion • Power distribution & redundancy: Vertiv™ PowerSwitch 7000, Vertiv™ Liebert® STS2, Vertiv™ Liebert® RXA • In rack power: Vertiv™ PowerDirect | <p>Once you've identified the right category:</p> <ul style="list-style-type: none"> • Review architectures • Explore performance data • Check use cases and specifications • Connect the dots across the full grid to chip ecosystem |
|---|---|--|---|

Power train

(from grey space to white space)

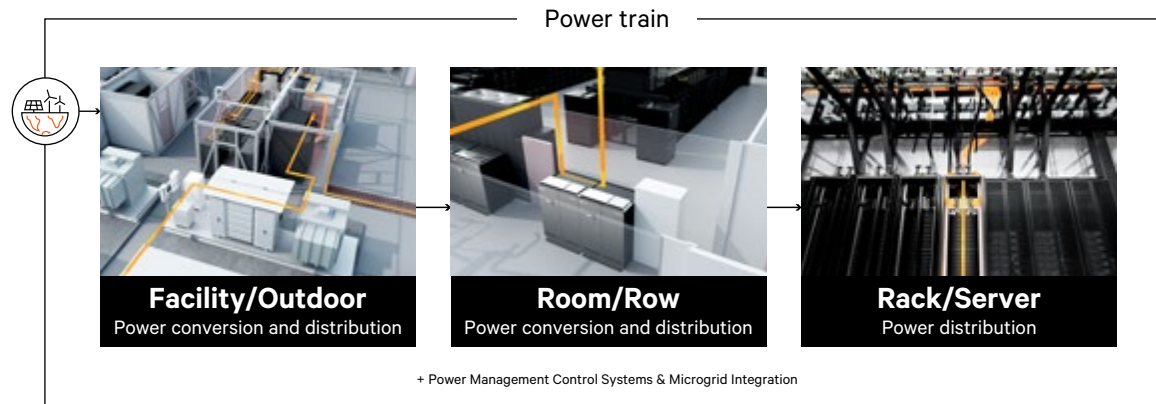

Designing a state-of-the-art data center power train requires:

- Power engineering excellence
- Knowledge on servers loads dynamics (CPUs and GPUs)
- Solutions capabilities
- Complete products and services portfolio

Power train encompasses the entire grid-to-chip power distribution chain.

Power train in an evolving landscape: Timeline

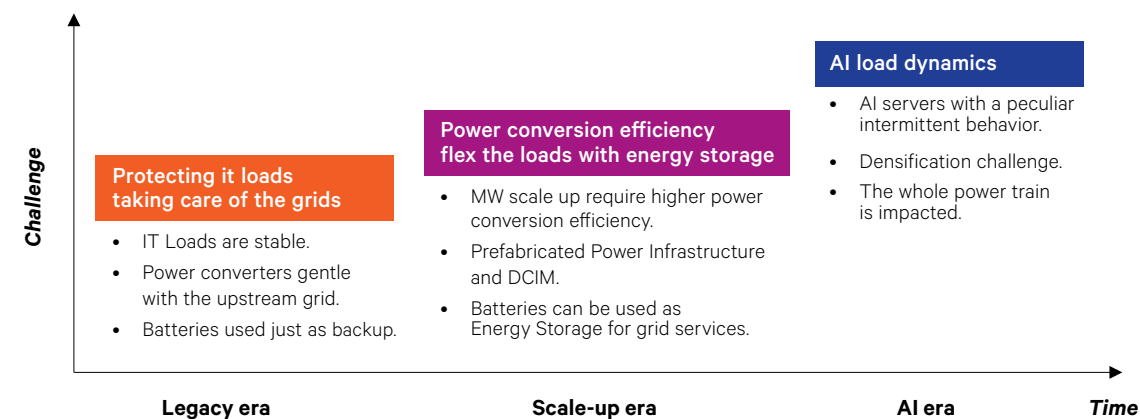

AI era power train

The rapid evolution of high performance is driving data center power densification through all the power train components. Vertiv brings together hardware, software, and services across the entire power train.

- ✓ Current portfolio
- ✓ Portfolio compatibility

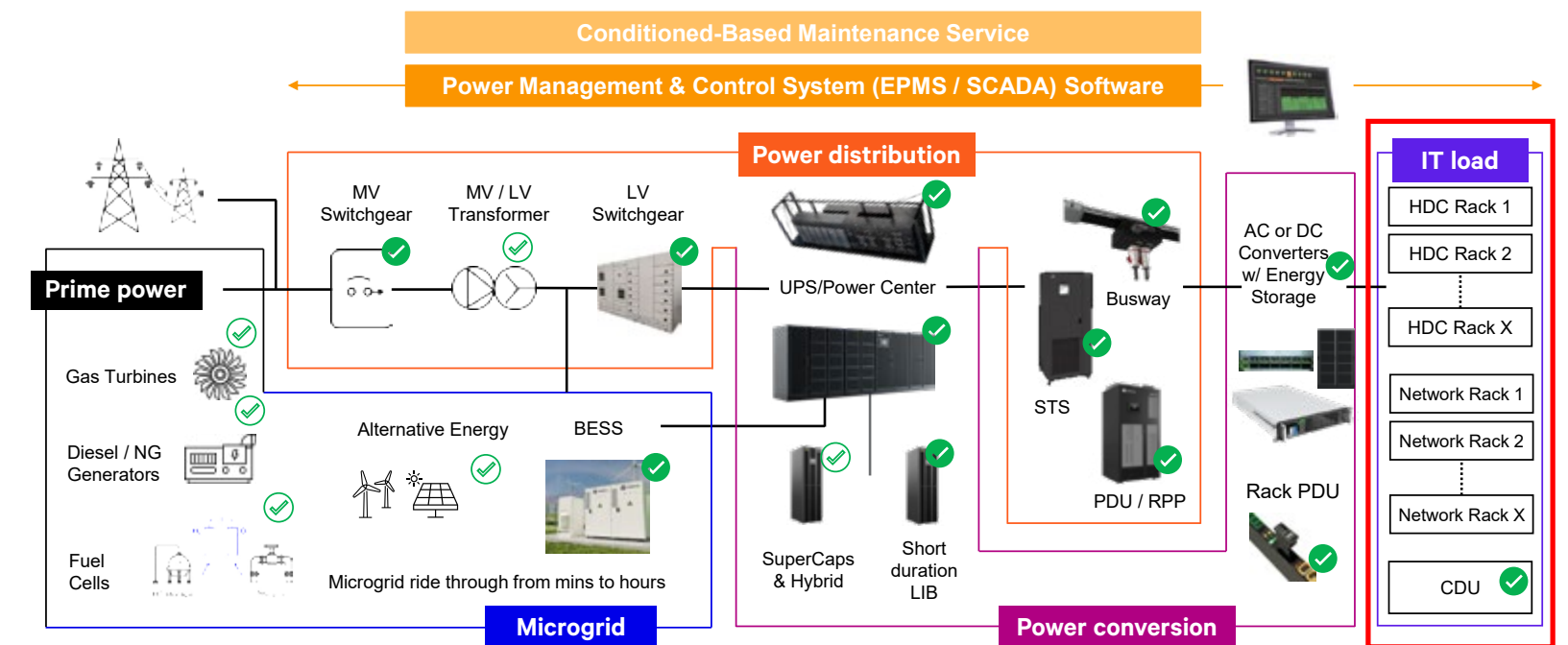



Enabling data centers to support the next generation of computing demand (AI / HPC / accelerated compute)

The first stage of the data center power train converts incoming electricity to lower voltage and distributes it across major systems, while providing backup power during grid outages.

Key low voltage components include switchgear, UPS with batteries, and backup power sources.

- **Switchgear** receives utility power, divides it into streams, and protects downstream equipment.

- **UPS systems** condition power to prevent spikes or sags and use battery energy to ride through grid faults.
- **Backup power sources** (generators or battery energy storage) supply power for longer outages, reducing downtime and reliance on the grid.
- **Automatic Transfer Switches (ATS)** switch the load to backup power when utility power fails or is unstable.

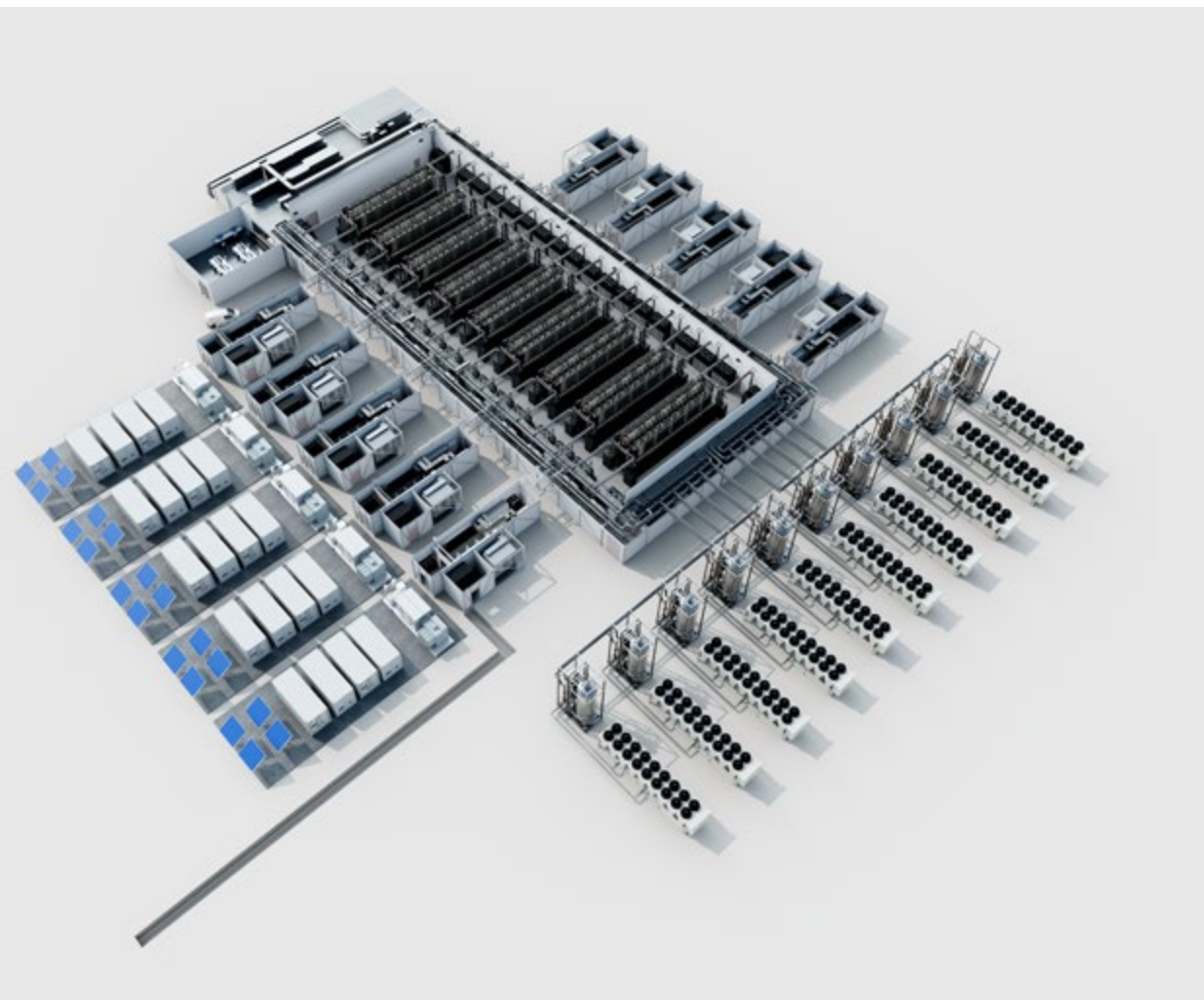

AI loads effects on data center power train components

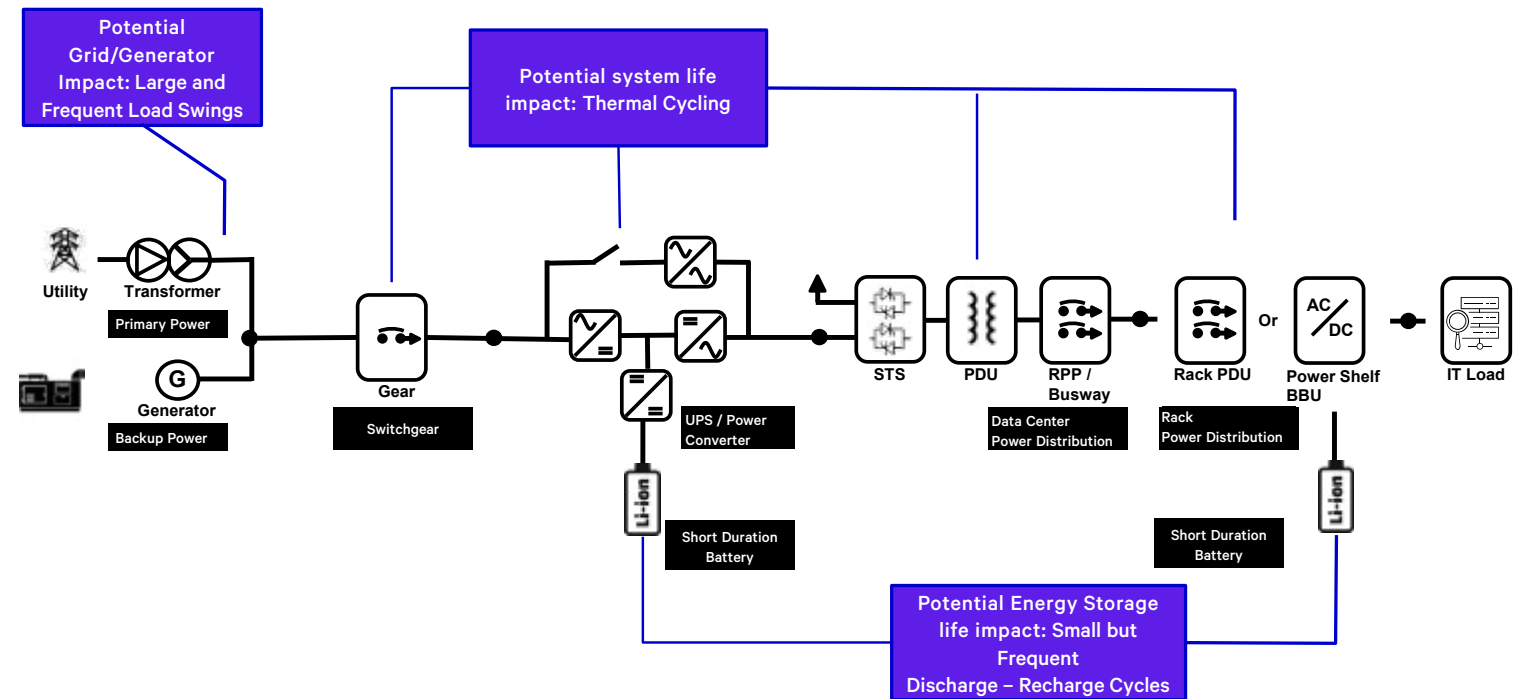

The heart of the data center power system

The UPS system is central to data center availability and is evolving to meet changing demands. Modular and parallel UPS designs allow operators to add capacity or redundancy without disrupting operations, supporting higher energy consumption.

Smaller-footprint UPS modules save space, accommodate higher rack densities, and increase ROI, while integrated UPS-switchgear blocks further reduce footprint and speed deployment. Advanced UPS controls now enable dynamic interaction with the grid, balancing supply and demand, reducing peak loads, and supporting growth within grid limitations.



©2026 Vertiv Group Corporation



AI loads management features

At UPS level, two approaches can be taken to eliminate/minimize the AI load impact on the power train or batteries.

Feature 1: Battery shield

Minimize impact on batteries

UPS FW is modified to avoid battery involvement in repeated upward load steps, which are passed from the IT load to the input source.

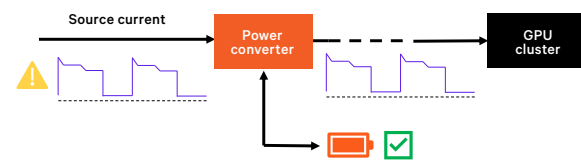

Feature 2: Input power smoothing

Minimize impact on grid/generators

UPS FW is modified to draw relatively constant power from the input source, by discharging and recharging batteries or capacitor bank to cover the load demand power deviating from average.

Batteries will have additional stress from constant charging & discharging.

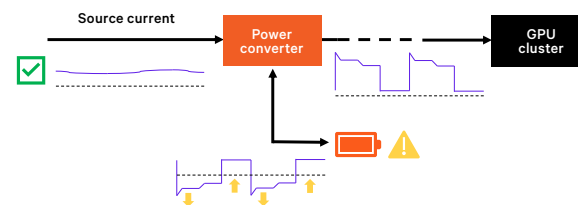

Power train AI trends

Drivers

AI loads management

Needs/Objectives

- Rapid load variations driven by GPU for AI training and inference cycles.
- Thermal & electrical stress on power train equipment.
- Need for fast control loops and adaptive response.
- Integration of energy storage to smooth transients.
- **Goal:** Stable and reliable power under fast and dynamic AI load profiles.

Power train densification

- Exponential growth in rack power density due to GPU clusters.
- Need for compact and thermally efficient designs with bigger power blocks.
- Pre-engineered, high-density power blocks to increase the speed of deployment.
- Leverage new datacenter power train architectures.
- **Goal:** Deliver more power in less space, with higher efficiency.

Power management: Evolving critical power needs

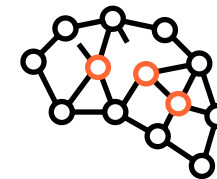

AI densification & load management

- Dynamic AI workload management.
- High capacity building blocks and optimizing distribution.
- Impact on Data Center Powertrain.

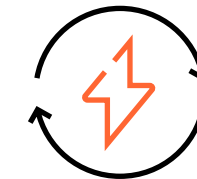

Power availability & sustainability

- Enable BYOP and Microgrid strategies to complement grid.
- Coordination with on-site generation.
- Implement sustainable and cycling energy storage solutions.

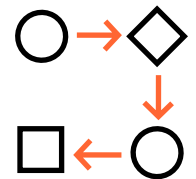

Operations and deployment speed and flexibility

- Modular build outs, standardize work.
- Prefabricate Power Infrastructure design considerations.
- Unified View on monitoring and control.

Power train design for the AI era

1. With the rise of AI and accelerated computing, data center power infrastructure faces increasing pressure from multiple sides: higher power demand, more dynamic workloads ("spiky loads"), and greater efficiency requirements.
2. Technology is evolving at faster pace than ever: flexibility and scalability to adapt as AI demand grows are key.
3. Robust, modular and scalable power train designs start with a holistic system view and rely on advanced device features.
4. AI-ready UPSs must work with increased capacity and amperage batteries, feeding high-density power distribution.
5. Larger building blocks (more MW in a single block) and integrated solutions enable scale and speed of execution.
6. Long runtime backup systems (BESS) allow flexibility and buffer for power and genset limitations.
7. Advanced monitoring and control integrate information to manage complexity and scale.



Large power converters

Traditional UPS systems were designed for steady, predictable IT demand, not sudden spikes. Vertiv's next-generation power infrastructure is built to handle rapid load changes, reduce battery strain, and help maintain grid stability.



Vertiv™ Trinergy™ (1500-2132 kW)



Vertiv™ PowerUPS 9000 (625-1250 kW)

Scalable power for AI training and hyperscale data centers

AI training facilities operate at multi-megawatt scale and require ultra-fast power response. Vertiv large power systems combine continuous-duty performance with advanced control algorithms validated under real AI load simulations.

Vertiv large UPS systems are designed to manage AI power loads.

Featured solutions

- Vertiv™ Trinergy™ (1500-2000 kW)
- Vertiv™ PowerUPS 9000 (625-1250 kW)

Key benefits

- Instant load response up to 100% step changes.
- Vertiv Trinergy and Vertiv PowerUPS 9000 are designed to handle step load profile and steep load changes.
- Enhance your power reliability with distributed battery systems.
- Input Power Smoothing protects grid and upstream gear.



Flexible, resilient UPS solutions for variable AI loads

Vertiv™ UPS are resilient, with the ability to handle the pulsing load profile of high-performance computing applications

AI power loads are changing the pattern of the electrical demand in AI data centers from a constant pattern to a very variable pattern.

Two possible scenarios to be highlighted:

- The user wants to avoid hitting the electrical source or local generators, which aren't sized to withstand the rate of change required by these loads.
- The user wants to avoid hitting the battery to prevent accelerating its aging due to small but frequent discharge/recharge cycles.

Vertiv™ UPS systems can support both scenarios and allow power protection and quality for every case through resilient design and flexible algorithms that manage all available AC and DC sources.

Vertiv has developed a behavioural model and is working with a leading GPU manufacturer to apply these loads to a data center one line.

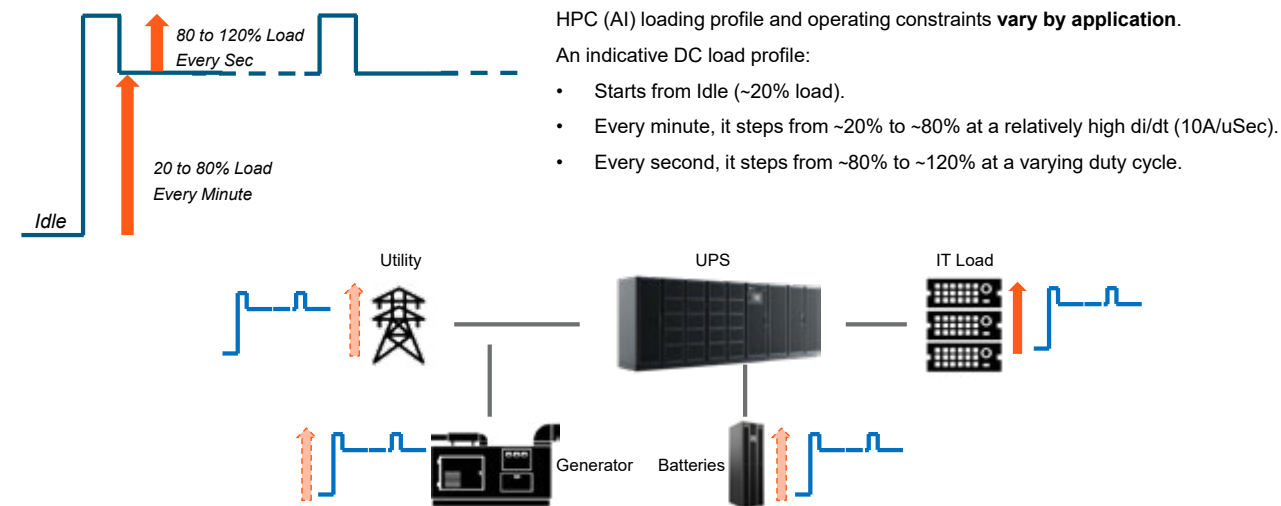

Goal: Supporting such load steps on UPS while minimising battery/generator hits.

Vertiv™ Trinergy™ overview and benefits at a glance

Elevating performance, modularity, resilience, reliability and efficiency for your power needs.



Vertiv™ Trinergy™ delivers proven efficiency up to 97%.



Designed, manufactured, tested and available across **the globe**.

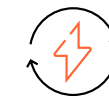

The ultimate optimized high-power solution for global standards and easy installation.



Skid-mount and containerized power solutions for easy deployment.

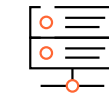

Best-in-class modular UPS for maximum flexibility from room to pre-fabricated deployment.

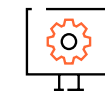

Rich digital experience Service empowered by data across entire lifecycle with Vertiv™ LIFE™ Advanced Incident Management and Condition Based Maintenance.



Ready to integrate different energy and backup power sources, including lithium-ion and nickel-zinc, with **>97% efficiency**.



Hot and easy serviceability for no interruption, even during.



AI ready to support fast dynamic power loads.



Vertiv™ Trinergy™

Continuous backup power

Vertiv™ Trinegy™ has a continuous-duty booster converter.

Unique UPS on the market with continuous-duty booster converter at full load.

Vertiv™ Trinegy™ - AI use case examples

AI / HPC data centers	Powers high-performance GPU clusters and AI training servers that have rapid, unpredictable load spikes.
AI research facilities	Provides stable, high-capacity power for laboratories running large-scale simulations, neuralnetwork training, or experimental AI hardware.

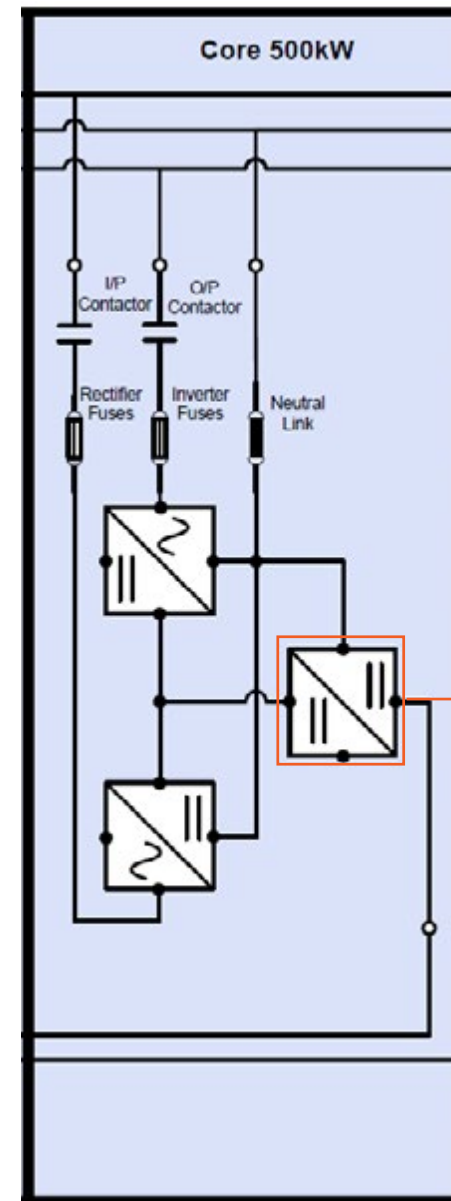

Thanks to cutting-edge hardware design and with advanced control techniques, **Vertiv Trinegy is the only UPS that can run on backup power source at full load for an indefinite amount of time.**

Its design allows direct connection of DCsources to the internal DC bus, which allows optimized integration with fuel cells.

Vertiv Trinegy has a continuous-duty, solid state static bypass switch.

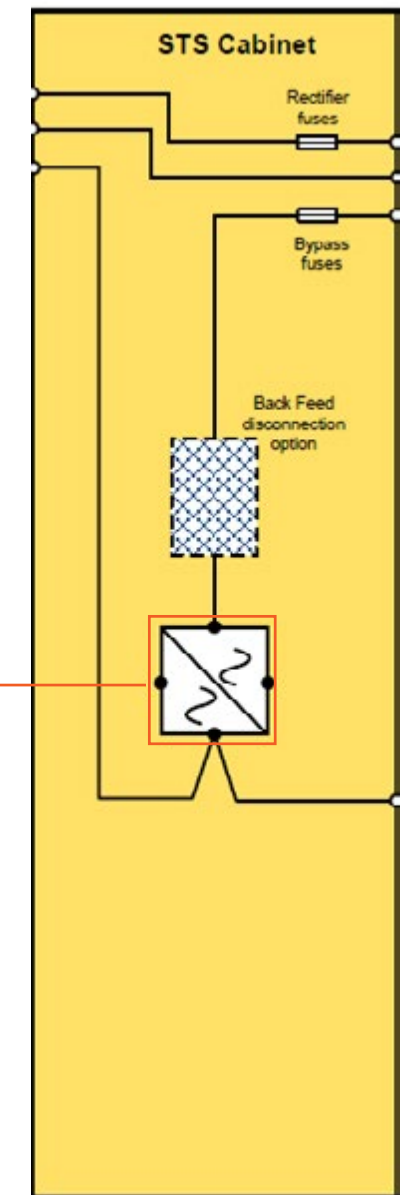



Vertiv™ Power UPS9000

Elevating performance, modularity, resilience, reliability and efficiency for your power needs.



1250kW 415Vac (CE)

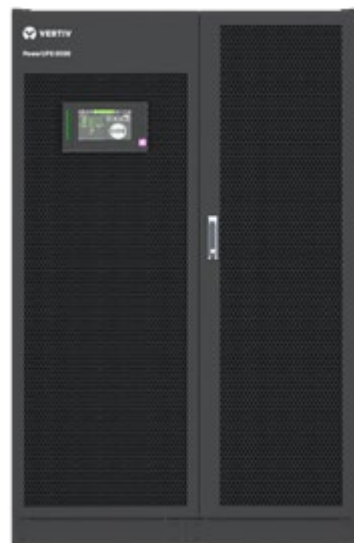

1250kW 415 (CE) compact frame

- 1 **Achieving up to 97.5% efficiency** in double conversion provides total cost of ownership (TCO).
- 2 **Compact footprint and high-power density**, essential to address the increasing data center power demand while managing space constraints, from room to pre-fabricated deployment.
- 3 **AI ready UPS system**, support fast dynamic power loads.
- 4 **Condition based maintenance**, value-added maintenance plan maximizing equipment uptime, reducing operational costs.
- 5 **Hot and easy serviceability** for no interruption, even during maintenance or power upgrades.
- 6 **Rich digital experience** and advanced monitoring with Vertiv™ LIFE™ Services.

Note: The content of these slide is not intended to be definitive or even a sales proposal, as it is subject to the company's ongoing technical and commercial developments. The presentation and its content are confidential and non-disclosable.

Key benefits

- High power density & compact footprint: Designed for large-scale data centres and AI workloads with modular architecture, and footprint up to **50% smaller** than previous generations.
- High efficiency: Achieves up to **97.5%** in double-conversion mode, delivering lower TCO and maximizing energy usage efficiency.
- Scalable large-capacity performance: Single-frame capacity up to 1250 kVA, based on 125kVA power modules to grow with the installation's power needs.
- Parallel systems scaling up to 5 MW.
- Designed for AI/high-density operations: Engineered for data centre needs and workloads, including AI, with versatile battery compatibility and simplified installation.
- Compatible with Vertiv™ Energy Core Lithium energy storage offering, and multiple battery technologies.



Vertiv™ PowerUPS 9000

Vertiv™ PowerUPS 9000 - AI use case examples

AI training clusters	Handles fast, high GPU power spikes with strong overload capacity and stable power.
Edge AI deployments	provides uninterrupted power for edge sites running real-time AI inference, autonomous systems, or IoT analytics.
Scalable AI growth	Modular 125 kW building blocks let AI data centers expand power protection as GPU racks increase.
Rapid AI deployment	Fits room-based, prefab, and containerized AI compute sites for fast rollout.



Medium power



Vertiv™ Liebert® APM2 (30–600 kW)

AI is expanding beyond core data centers — reaching the edge, where agility matters most. Vertiv™ Liebert® APM2 combines compact footprint, scalability and AI-ready design — protecting mission-critical cooling and workloads with unmatched efficiency.

Featured solutions

- Vertiv™ Liebert® APM2 (30–600 kW)

Key benefits

- **True modular scalability**
The Vertiv Liebert APM2 uses hot-swappable power modules and a flexible architecture that allows a single unit to scale up to 600 kW, making it ideal for modular and edge AI deployments where you may start smaller and ramp up as demand grows.
- **High power density, compact footprint**
With efficiencies up to 97.5 in double conversion mode and you get more power in less space. That's a big win when deploying modular AI pods or edge racks.
- **Front-access maintenance / fast serviceability**
The Vertiv Liebert APM2 is built for ease of service with hot-swappable modules, front access to cable terminations, and an optimized MTTR of < 0.5h. This means modular deployments can stay online with minimal disruption while upgrades or maintenance happen.
- **Flexible battery and environment compatibility**
Supports a wide range of battery configurations (Li-ion or VRLA), and accommodates high ambient temperatures (up to 50 °C). That fits modular or edge locations which might not have full data-center conditioning.
- **Smart monitoring & network integration**
Equipped with a full-color touchscreen HMI, network connectivity (SNMP, Modbus, etc.), and predictive diagnostics. For modular AI locations, this means you can monitor multiple units centrally, scale, and manage uniformly.



Vertiv™ Liebert® APM2



Vertiv™ Liebert® APM2 (30–600 kW)

Vertiv™ Liebert® APM2 (30–600 kW) - AI use cases

High-density AI training racks	Because the Vertiv Liebert APM2 supports very high power density (up to 600 kW in a compact frame). Use case: Protecting large-scale GPU clusters (AI training) in dense racks, where each rack may draw a lot of power.
Scalable AI compute infrastructure	The system is modular (power modules are hot-swappable, plus Vertiv FlexPower technology) so you can expand capacity as AI demand grows. Use case: Incrementally adding UPS capacity when scaling up from a few GPU racks to a full AI data center.
Energy-efficient AI operations	Extremely high efficiency: up to 97.5% in double-conversion mode and up to ~98.8-99% in Dynamic/ECO modes. Use case: Reducing power losses and cooling demand in AI data centers, lowering TCO.
Reliability in AI environments	The Vertiv Liebert APM2 can operate in high ambient temperatures (up to 50°C, with derating) Use case: AI edge data centers (or on-prem AI clusters) in non-ideal cooling environments (e.g., containerized or prefabricated sites).
Predictive maintenance for AI load	Supports predictive maintenance notifications (via Vertiv LIFE / monitoring) to avoid downtime. Use case: Preventive maintenance in AI systems where unplanned UPS downtime could interrupt training or inference jobs and cause large losses.
AI workloads with dynamic load profiles	The UPS design supports “intelligent paralleling” and load compatibility from 0.5 lag to 0.5 lead power factor. Use case: Handling fluctuating, real-world AI load profiles (e.g., when GPU utilization spikes or drops).
AI training clusters	Handles fast, high GPU power spikes with strong overload capacity and stable power.
Edge AI deployments	provides uninterrupted power for edge sites running real-time AI inference, autonomous systems, or IoT analytics.
Scalable AI growth	Modular 125 kW building blocks let AI data centers expand power protection as GPU racks increase.
Rapid AI deployment	Fits room-based, prefab, and containerized AI compute sites for fast rollout.



Energy storage

**Beyond backup —
Intelligent energy for the AI era.**

In the world of AI, batteries have evolved from passive reserves to active energy managers. Vertiv’s lithium-ion storage systems deliver fast response, longer life, and integrated intelligence that turns stored energy into strategic capacity.

By smoothing AI load peaks and participating in grid balancing, Vertiv storage brings sustainability and savings into one solution — helping data centers achieve both resilience and responsibility.

Vertiv™ EnergyCore, lithium ion battery cabinets

Key benefits

- Purpose-built lithium-ion energy storage for data centers, designed to handle modern compute loads including AI.
- Accurate, real-time State of Charge (SoC) and State of Health (SoH) monitoring via built-in BMS, enabling predictive maintenance and deeper operational visibility.
- Reduced total cost of ownership thanks to longer battery life (versus traditional VRLA), and lower maintenance overhead.
- Seamless integration into the power chain: connects with UPS and power infrastructure to smooth input current during AI compute load swings and integrate with grid/renewables.



Vertiv™ EnergyCore
lithium ion battery cabinets

Vertiv™ EnergyCore - AI use cases examples

Smoothing power spikes in AI training /inference	AI workloads, especially GPU training, can have very dynamic power demands. Vertiv EnergyCore can absorb these rapid load changes, reducing stress on the UPS and power infrastructure.
Real-Time State of Charge (SoC) management for AI loads	The battery management system (BMS) uses advanced algorithms to precisely track SoC even under highly variable AI compute loads.
Integrated communication to Vertiv™ UPS	Vertiv EnergyCore communicates key parameters, like State of Health (SoH), to the UPS. This enables predictive maintenance and maximizes power management capability at system level.
Optimized control for short power cycles	Purpose-built to support rapid charge-discharge cycles during critical AI compute tasks.
Space efficiency in high-density AI data centers	Compact design, helping save data center space — useful when racks are dense for AI compute.
Improved power quality during AI load transients	Integrated operation between the battery and the power converter helps smooth input source current, reducing flicker or instability as AI clusters swing load.

Vertiv™ Liebert® APM2 – LIB

Internal lithium-ion battery module

APM2 model compatible

- – 240V internal lithium battery;
30kVA for APM2 UPS Frame1;

Summary of offering features

Premium performance

- Up to 30kva
- Parallel and serial using
- Plug-in design
- Built-in power supply
- Cold startup pre-charge circuit
- Hot-swappable, easy to service
- CE,UL1973,UL9540A

Modularity & redundancy

- Hot swappable
- Parallel and serial configuration
- Plug-in design

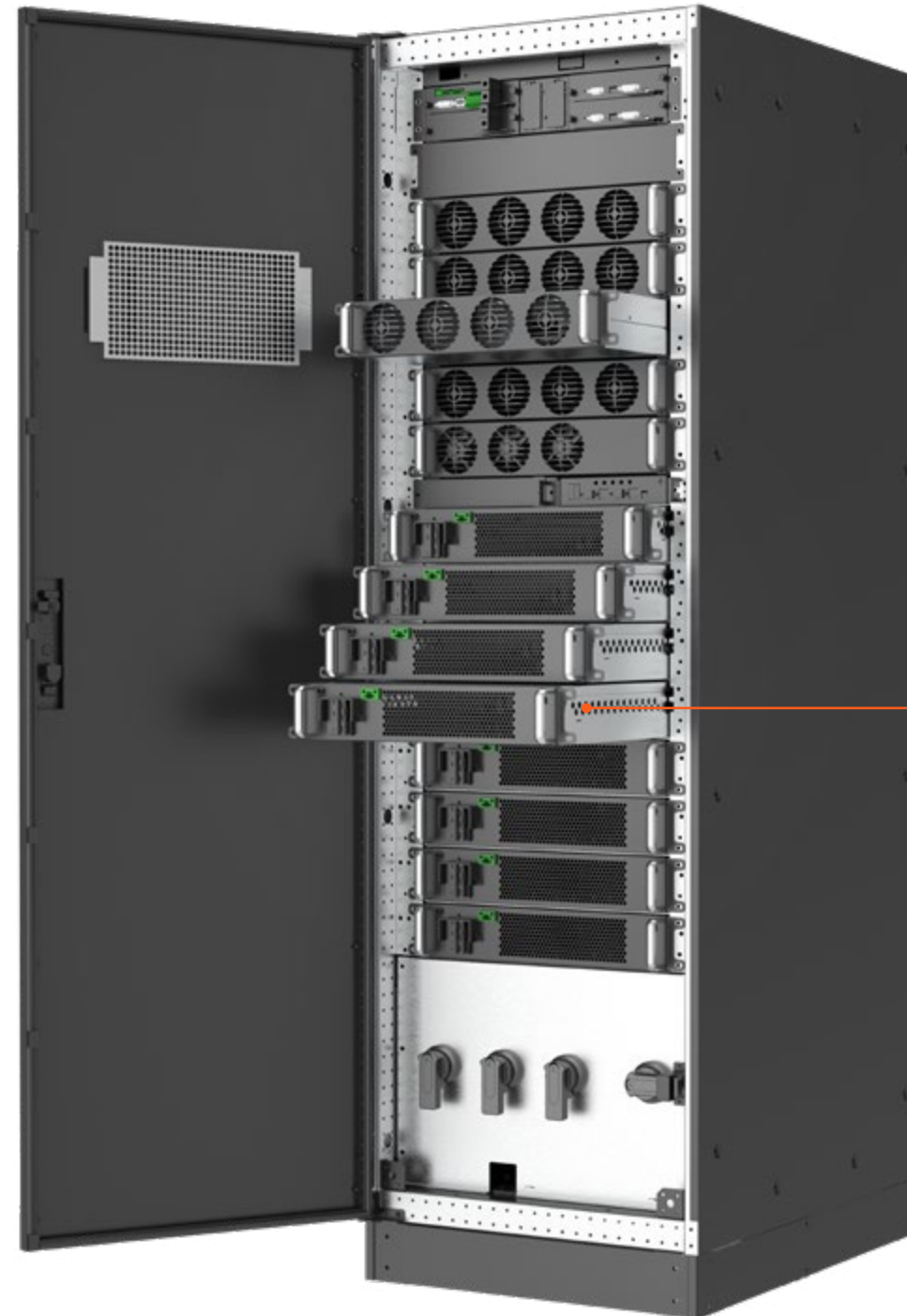

Flexibility

- Battery shelf suitable for all voltage system
- 208V/400V/480V
- Compatible with VRLA battery
- UP to 8 shelves in frame1
- 120KW 10minutes
- Energy storage flexibility - VRLA/APM2 internal LiB module

User/ service friendship

- CAN/RS485 connection
- Full modular design
- Rich information on HMI
- Firmware upgrade thru Paraset
- Front access

Vertiv™ Liebert® APM2



Power solutions & distribution



Redundant power paths for continuous AI operations

AI systems require constant uptime — no power interruptions, no single points of failure. Vertiv's PowerSwitch and STS solutions support seamless transfer and balanced distribution across dual power feeds.

Featured solutions

- Vertiv™ PowerSwitch 7000 (160–630 A)
(2027,H1: 1250-2000 A, H2 800-1200A UL/CE)
 - Vertiv™ Liebert® STS2 (1250–1800 A)
 - Vertiv™ Liebert® RXA Remote Power Panel (up to 400 A)
- Vertiv™ PowerSwitch 7000

Key benefits

- Seamless transfer of loads between dual independent UPS systems — <math>< \frac{1}{4}</math> cycle switching supports that there is essentially no disruption to the critical loads.
- True internal redundancy with dual redundant power supplies, segregated main functions and integrated SCRs eliminate a single point of failure.
- Front-access, modular design makes maintenance fast and safe: units can be placed tight to walls or back-to-back, saving valuable floor space.
- Advanced monitoring with waveform capture and HMI touchscreen supports real-time diagnostics and performance insights.
- Vertiv PowerSwitch 7000 delivers high-availability power protection with rapid, seamless transfer to keep AI and high-density loads continuously supported. Its compact, front-access design simplifies installation and service, integrating effortlessly into dual-power architectures as a reliable safeguard for mission-critical operations.



Vertiv™ PowerSwitch 7000

Vertiv™ PowerSwitch 7000 - AI use cases

Zero-downtime for AI servers	Seamless transfer between dual UPS sources (<math>< \frac{1}{4}</math> cycle) keeps GPU clusters and inference servers running.
High reliability	Redundant internal design eliminates single points of failure for mission-critical AI workloads.
Space-efficient	Compact footprint fits dense AI racks and edge/colocation sites.
Easy maintenance	Front-access, serviceable design allows upgrades without disrupting operations.
Monitoring & diagnostics	Real-time visibility into load, power quality, and harmonics offer stable, efficient AI operations.



Vertiv™ Liebert® STS2 Solution overview and benefits at a glance

Elevating flexibility, performance, and features for enhanced customer experience and solution offering.



Performance

- Proven legacy technology with a track record of reliability.
- Seamless power transfer between two power sources in $\leq 4\text{ms}$.
- Highly reliable fault tolerant design with system redundancies.



Flexibility

- Static transfer switch with ampacities up to 1800A 4P (3P as ETO).
- Front access with Form 4B Segregation design.
- Withdrawable breakers/isolators.

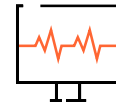

Features

- Dual-Key Interlock for bypass procedure.
- Tested and integrated in Vertiv factory.
- Withdrawable breakers/isolators.



Vertiv™ Liebert STS2 Solution 1250-1800A

Vertiv™ Liebert® STS2 Chassis vs Solution - key advancements



Line Extension Scope:
Integration with LV Switchgear, leading to a full cabinet Vertiv Solution



Vertiv™ Liebert® STS2 Chassis - gaps

- No cabinet.
- Requires integration with LV Switchgear to operate.
- Slow/limited deployment on site, due to required integration.
- Higher TCO, due to separation between STS and Switchgear.

Vertiv™ Liebert® STS2 Solution - key improvements

- Cabinet with 5x Switches and top customer connections.
- All-in-one Vertiv product as standard.
- Fully integrated in Vertiv factory to minimize on-site work.
- Optimized TCO, thanks to service and commissioning optimization.
- between STS and Switchgear.

STS2 Solution is a line-extension of the STS2 Chassis boosting the value proposition and drive STS portfolio in a unique position.

Vertiv™ Liebert® RXA benefits

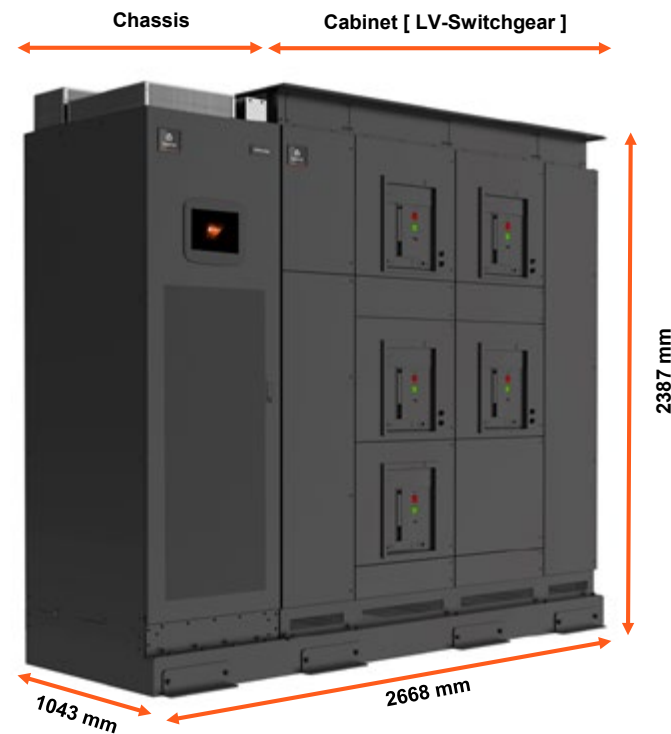

Vertiv™ STS2 Solution 1250-1800A

Ratings and voltages	1250/1400/1600/1800A 380/400/415V 50 Hz
Weight	Unit: 2130-2430kg Shipping: 2200-2500kg
Dimensions	2668mm(W) x 1043mm(D) x 2387mm(H)
Compliance	IEC 62310-1&2 for Chassis IEC 61439-1&2 for Cabinet RoHS & REACH

Vertiv™ Liebert® STS2 - AI use cases

High-availability AI servers	Instantaneous transfer (<math>< \frac{1}{4}</math> cycle) between power sources keeps GPU clusters, training farms, and inference servers running without interruption.
Dual-bus redundancy for edge AI / colocation	Supports single- or dual-cord loads with high uptime, meeting SLAs for AI services.
Maintenance without downtime	Enables UPS or power infrastructure upgrades while AI workloads stay online.
High-density / high-power AI racks	Handles heavy power draws from GPU servers safely and reliably.
Monitoring & control	Integrates with DCIM to track power, detect failures, and maintain AI system reliability.



Vertiv™ Liebert® RXA

- 1 Intelligent power monitoring (via Liebert DPM)**
 - The system includes real-time metering (voltage, current, power, energy) at both main input and branch circuit levels.
 - It provides 1% accuracy in metering.
 - It raises audible and visible threshold alerts on power and environmental conditions.
 - These capabilities enable precise monitoring of power usage effectiveness (PUE), and help optimize load distribution.
 - The system supports remote monitoring, integrating with BMS (Building Management Systems).
- 2 Configurable & scalable power distribution**
 - The RXA is modular: flexible panel board accepts 1-, 2-, 3-, or 4-pole breakers, up to 84 poles per unit.
 - Multiple form factors: single, double, triple, or quadruple cabinets.
 - Hot-swappable panel boards: you can replace/add branch circuits (in <math>< 20</math> seconds) while the rest of the system remains live.
 - This modularity supports scaling power capacity as AI infrastructure grows (e.g., adding more GPU or AI compute clusters).



Vertiv™ Liebert® RXA

3

Compact footprint

- High density: 400 A / 84 poles in just 0.19 m².
- Even a double unit gives 800 A / 168 poles in 0.38 m².
- The small footprint saves floor space, which is valuable in data centers with large AI clusters.

4

Reliability & high availability

- Ensures “continuous power to critical applications.
- Pre-configured, certified, and tested, reducing risk and deployment time.
- The intelligent monitoring can respond quickly to load imbalance, reducing risk of overload or failure.
- Supports local and remote emergency power-off (EPO).

5

Integration & management

- Navigation menu for system programming, load management, and the ability to import/export configurations between units.
- With its monitoring and control, you can proactively manage power in real-time, potentially tying into analytics systems — enabling predictive maintenance.
- Reduced operational cost because of better visibility and control.

Vertiv™ Liebert® RXA - AI use cases

High-density AI racks	Compact, high-power distribution supports GPU clusters and dense server deployments.
Scalable growth	Modular design allows adding circuits or expanding capacity as AI workloads increase.
Maintenance without downtime	Hot-swappable breakers enable changes while servers stay live.
Monitoring & load management	Real-time per-circuit visibility ensures power reliability and prevents overloads.
Edge and colocation AI sites	Flexible, pre-configured, and space-efficient for remote or constrained deployments.



DC power

Vertiv™ PowerDirect In-Rack 33 kW – OCP compliant

AI workloads demand massive, fast, and stable power — and the Vertiv™ PowerDirect In-Rack delivers.

Purpose-built for high-density GPU environments, PowerDirect provides up to 132 kW per rack, ultra-high efficiency, and modular scalability. With integrated power telemetry and real-time load insights, it offers stability to your AI systems, optimized, and always on. Gain the intelligent, high-density power backbone your AI infrastructure needs to perform at full speed.



Vertiv™ PowerDirect In-Rack 33 kW

Key benefits

- **High power density**
 - Delivers up to 33 kW per 1U shelf, and up to 132 kW per rack.
 - Very compact — saves valuable rack space.
- **Modular and scalable**
 - Hot-swappable PSU modules — you can add more power supply units (PSUs) live, without shutting down.
 - Multiple “shelves” can be added to scale up capacity as IT load grows.
- **High efficiency**
 - Peak efficiency is ~ 97.5%.
 - This reduces heat loss, electricity cost, and cooling demands.
- **Flexible power input**
 - Supports AC input (single-phase or three-phase) and HVDC (DC) input.
 - This flexibility makes it suitable for modern data center architectures.
- **Redundancy / reliability**
 - Supports N+N or N+1 redundancy to maintain continuous power.
 - Integrated protections: overvoltage, over-current, temperature safeguards.
- **Power management / monitoring**
 - Power Management Module (PMM) can monitor up to 48 PSUs.
 - Real-time telemetry, load balancing, remote monitoring capabilities.
- **ORv3 High Power Rack (HPR) compliant**
 - Compatible with Open Compute Project (OCP) ORv3 rack designs - ready for modern infrastructure designs.
 - OCP Form factor – 21” width, 10U (open unit) height.



Vertiv™ PowerDirect In-Rack 33 kW

Vertiv™ PowerDirect In-Rack 33kW 50V - AI use cases examples

High-demand AI / HPC clusters	AI training (e.g. GPU/TPU clusters) can demand huge, consistent power. The high density (132 kW/rack) means you can support more AI compute per rack.
Scalability for growing models	As AI models or infrastructure grow, you can add power modules live without disrupting training or inference — key for scaling.
Efficiency reduces cost	High efficiency minimizes power loss — lower electricity and cooling costs, which is very relevant when running power-intensive AI operation.
Flexible power architectures	Because it supports both AC and HVDC, the Vertiv PowerDirect Rack can integrate into modern data centers that use DC power distribution to improve efficiency for AI clusters.
High reliability / redundancy	AI workloads (especially in production) often cannot tolerate downtime. The redundant design helps provide continuous power for critical AI tasks.
Optimized for OCP / Hyperscale AI deployments	Being OCP ORv3 HPR-compliant makes it ideal for data centers built around open and scalable hardware architectures, which many AI-driven hyperscale data centers use.





Vertiv.com | **Vertiv Infrastructure Limited**, Fraser Road, Priory Business Park, Bedford, MK44 3BF, VAT Number: GB605982131

© 2026 Vertiv Group Corp. All rights reserved. Vertiv™ and the Vertiv logo are trademarks or registered trademarks of Vertiv Group Corp. All other names and logos referred to are trade names, trademarks or registered trademarks of their respective owners. While every precaution has been taken to ensure accuracy and completeness here, Vertiv Group Corp. assumes no responsibility, and disclaims all liability, for damages resulting from use of this information or for any errors or omissions. Specifications, rebates and other promotional offers are subject to change at Vertiv's sole discretion upon notice.

SL-80503 (R04/26)