



Vertiv™ Liebert® iCOM™ V1A Application

User Manual

English, Cod. 265193, rev. 19 - 2026.01.16

TABLE OF CONTENTS

1	Touch Display	5
1.1	General	5
1.2	Main Page	5
1.2.1	Main Screen Customization	11
1.2.2	Searching	12
1.3	Event Detection	13
1.4	Connections	14
1.5	User Menu	15
1.5.1	Setpoints	16
1.5.2	Event Log	20
1.5.3	Display Options	21
1.5.4	Total Run Hours	22
1.5.5	Total Run Hours Mode Overview	23
1.5.6	Scheduler	24
1.5.7	Condenser (DX Air Cooled only)	25
1.5.8	Unit Overview (CW)	26
1.5.9	Unit Overview (DX)	26
1.5.10	System Overview	27
1.5.11	EconoPhase	28
1.5.12	High/Low Limits	29
1.5.13	Panel	30
1.6	Overview (Unit)	31
1.6.1	Unit Info	32
1.6.2	Fans	32
1.6.3	Compressors	33
1.6.4	Sensors	34
1.6.5	Condensers	35
1.6.6	Inputs	36
1.6.7	Outputs	37
1.6.8	Heating	38
1.6.9	Hum/Dehum	39
1.6.10	Chilled Water	40
1.6.11	Air Economizer	41
1.6.12	Energy Meter	42
1.6.13	T/H Graphs	43
1.6.14	Service Contacts	44
1.6.15	EconoPhase	45
1.6.16	Daily High/Low T/RH/DP	46
1.6.17	Fluid Economizer	47
1.6.18	ATS	48
2	Small Display	49
2.1	keyboard Icons and Functions	49
2.1.1	Contrast Adjustment	49
2.1.2	Audible and Visible Indicators	49
2.2	Password Protection	50
2.3	Unit ON/OFF	50
2.3.1	System On/Off	51
2.4	Main Screen	52
2.5	User Menu	53
2.5.1	Setpoints	53
2.5.2	High/Low Limits	56
2.5.3	Total Run Hours	58
2.5.4	Scheduler	60
2.5.5	Condenser (DX Air Cooled only)	61
2.5.6	Display Options	62
2.5.7	Logout	62
2.6	Unit Overview	63
2.6.1	Sensors	63
2.6.2	Fans	64

ENGLISH

2.6.3 Compressors 65

2.6.4 Condensers 66

2.6.5 Heating..... 67

2.6.6 Hum/Dehum 67

2.6.7 Chilled Water 68

2.6.8 Fluid Economizer..... 68

2.6.9 Air Economizer..... 69

2.6.10 EconoPhase..... 70

2.6.11 Inputs 71

2.6.12 Outputs..... 72

2.6.13 Energy Meter 73

2.6.14 ATS 74

2.6.15 Unit Info 75

2.7 System Overview 76

2.8 Events Report..... 78

2.8.1 Active Events..... 78

2.8.2 Status Report 78

2.8.3 Export Events 79

3 Events List..... 80

1 Touch Display

1.1 General

The controller contains a web server and is fully manageable through the touch display or web pages. Google Chrome is the recommended browser for accessing the website. A maximum of 3 web browser clients can be connected to the controller's web server.

1.2 Main Page

Figure below represents the Home Page.

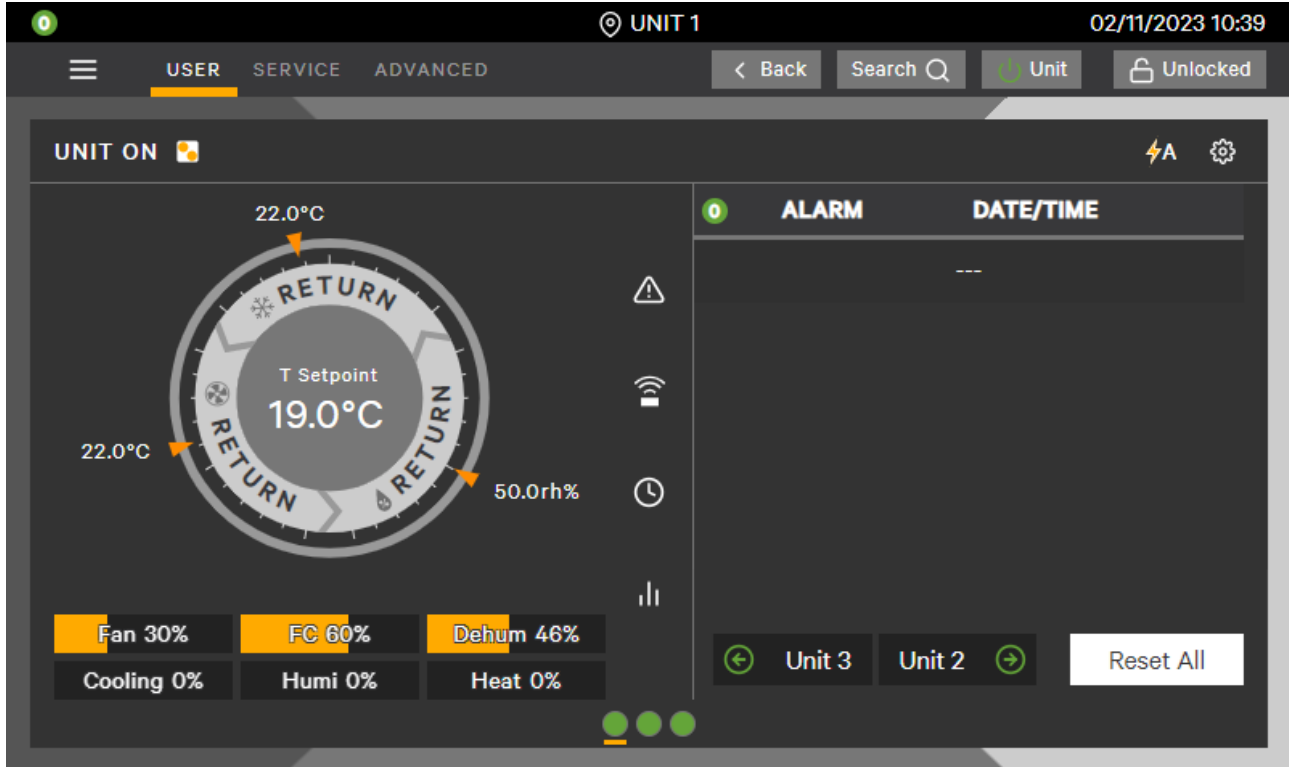

Status Header displays the number of active events, the unit name, and the current date and time.

Control Header contains menus for accessing User, Service, and Advanced settings. Access to these menus is controlled by access level settings.

The Back button allows to return to the previous page. Note: From any menu, press the User icon  to return to the main window.

The Search button opens the menu for searching the location of control parameters (see the 'Searching' paragraph for further information).

The Unit button allows to Start/Stop the unit. Confirmation is required via a pop-up to start/stop the unit. This button is hidden if the user is not logged in.

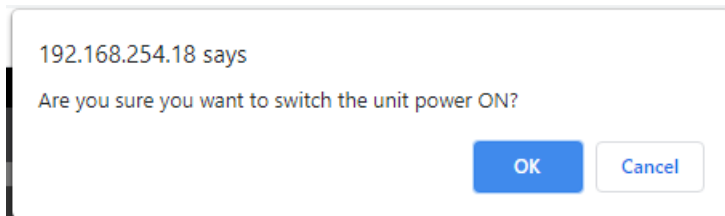

The System button allows to start the system. The system can only be switched ON by this button. Confirmation is required via a pop-up to start the system. This button is hidden if the user is not logged in or if the system is ON.

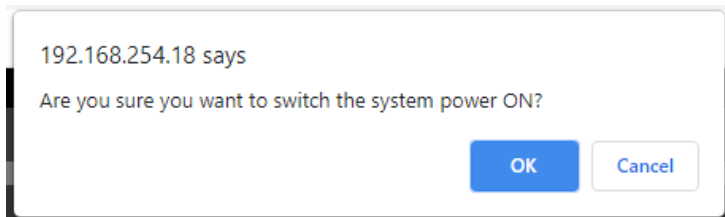

The System On/Off command is disabled by default. If enabled the system can be turned OFF or ON using the System On/Off button in the User/System Overview menu.

In Teamwork Mode 0 (No Teamwork) and without standby units, the System On/Off command will not have any effect on the units.

Locked Icon: The display is in read-only mode.

Unlocked Icon: The user is logged in, and the menus are accessible. Press the Locked button to enter the Level/Username and Password:



Level / Username	Accessibility
user	The User level (low level) allows for the modification of parameters such as temperature setpoint, which are typically used to define the operating point of the unit.
service	The Service level (medium level) enables the modification of parameters that define the operating mode of the unit.
advanced	The Advanced level (high level) allows for the identification of the unit based on the type of devices mounted on board.

The current Touch Display password can be changed by clicking the “Change...” button in the Login dialog. The new password must contain at least four characters and cannot be the same as the default password or the current password.

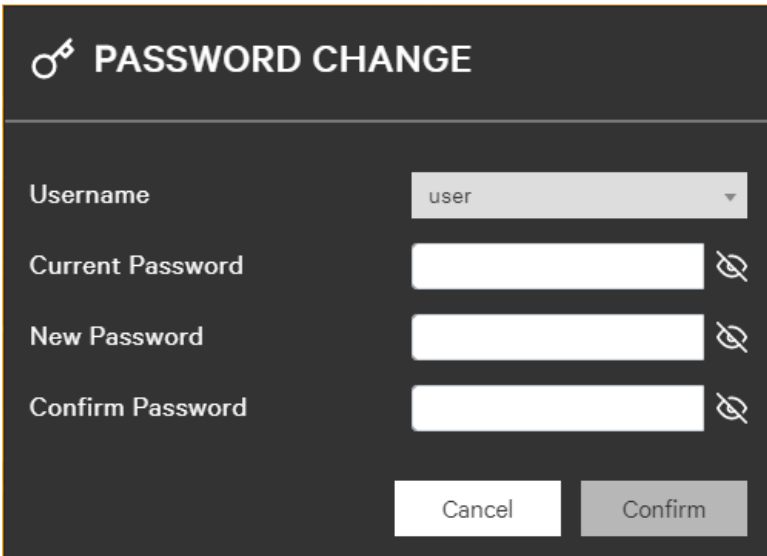

When the Touch Display password is lost or forgotten, it may be reset to its default via the iCOM3 Small Display (refer to chapter Small Display/Display Options) or contact Vertiv Service Technical Support.

ENGLISH

The Unit Status (followed by information about specific working conditions, overrides, or limitations) is displayed in the left corner of the panel. The table below provides details about the available statuses:

Unit status	Description
DISPLAY OFF	The unit is switched OFF by Display.
REMOTE OFF	The unit is switched OFF by Remote contact (digital input).
3 POS SWITCH OFF	The unit is switched OFF by 3 Positions Switch (digital input).
MONITORING OFF	The unit is switched OFF by BMS.
TIMER OFF	This state occurs when the unit is in sleep mode (OFF by Timer Mode).
ALARM OFF	The unit is switched OFF due to an alarm condition.
SHUTDOWN DELAY	The unit is going to OFF with only the fan continuing to operate for a defined time.
STANDBY	The unit is in standby mode. In standby mode, the unit remains powered but does not actively perform ventilation, cooling, heating, or other functions. The control system keeps essential electronics and communication interfaces operational, allowing the unit to respond quickly to a start command.
STANDBY BY THR	Not used.
ALARM STANDBY	The unit is in standby mode due to an alarm condition.
FAN BACK DRAFT MODE	The unit is in standby mode with the fan ON, operating at a dedicated fan speed.
UNIT ON	The unit is operating in automatic mode.
WARNING ON	The unit is operating in automatic mode with an active warning.
ALARM ON	The unit is operating in automatic mode with an active alarm.
OPENING DAMPER	The control is waiting for the Air Economizer or Return Damper (based on time or feedback) to open before activating the unit components.
POWER FAILURE	The main power supply is absent. The unit is running with compressors, heating, humidification, and dehumidification disabled, while the fan (if powered) and CW valves continue to operate.
MANUAL	The unit is not in automatic mode; components such as fans, compressors, heaters, etc., can be manually activated.
RESTART DELAY	The unit is waiting for the restart delay time before starting.
OFFLINE	In the System Overview, the status OFFLINE will be displayed when the unit is either unavailable in the system or if communication between units is disabled.

The icon  in a panel with Unit Status content indicates the current Teamwork Mode:

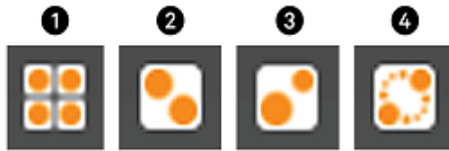

1 = No Teamwork

- The units work independently. Sensor values and setpoints are not shared.
- The control drives cooling, heating, ventilation, humidification, and dehumidification based on local requests.
- Standby function and unit rotation are possible; cascade is not allowed.

2 = Teamwork Mode 1 (Parallel)

- The control uses the system PI's for driving cooling, heating, ventilation, humidification, and dehumidification.
- In this teamwork mode, all relevant control parameters are shared; if a value changes in any of the units, all other units will follow with the same changed setting.
- This teamwork mode can be set in the case of Return or Return + Supply Limit or Remote temperature control only.
- Fan speed control mode Supply and Delta Return/Supply are not available in TW1.
- Teamwork Mode 1 is not available if the EconoPhase option is set.

3 = Teamwork Mode 2 (Independent)



- The control drives cooling, heating, ventilation, humidification, and dehumidification based on local requests while avoiding operational conflicts with the other units in the network. For example: If one unit is on cooling, no other unit may start heating. If one unit is on dehumidification, no other unit may start humidification.
- In this teamwork mode, all relevant control parameters are shared; if a value changes in any of the units, all other units will follow with the same changed setting.

4 = Teamwork Mode 3 (Smart Aisle - Optimized Aisle)

- The control uses the system PI's for driving ventilation, humidification, and dehumidification. Local request is used for driving cooling and heating.
- In this teamwork mode, all relevant control parameters are shared; if a value changes in any of the units, all other units will follow with the same changed setting.
- This teamwork mode can be set in the case of Supply temperature control only.
- Fan speed control mode Supply, Delta Return/Supply, Cooling and Return CW Priority are not available in TW3.

The pop-up provides additional information about teamwork, including the number of Standby Units, Operating Units, and the Cascade Mode (Yes/No).

TEAMWORK MODE:	
PARALLEL	
Standby Units	1
Total Units	2
Cascade	No

The symbol  indicates the power supply line (A or B) feeding the unit. If the main control board is kept alive by Ultracap, the symbol  will appear.

This symbol  opens the main screen customization menu (refer to the 'Main Screen Customization' paragraph for more information).

The status of each connected unit in the system is displayed on the bottom line of the home page. The color of the symbol  indicates the status. Refer to the table below for colors and their respective statuses:

Color	Status
Grey	The unit is OFF or offline or in manual mode
Amber	The unit is in standby mode
Green	The unit is ON
Yellow	A warning is currently active
Red	An alarm is currently active

The  icon indicates the currently viewed unit. Selecting the icon will display the System Overview menus.

The  buttons allow navigation to the next and previous unit in the system.

The dial displays control sensors utilized by the application for managing cooling/heating, humidification/dehumidification, and ventilation, along with their reference values (or setpoints).

The 'Outer Dial value type' (Display Option menu) determines whether to display sensor readings or setpoints on the outer dial.

Touching the center of the dial reveals the following data:

- Current Temperature Setpoint used by the application for managing cooling devices.
- Current Humidity Setpoint used by the application for managing humidification and dehumidification.
- Current Fan Setpoint/Request used by the application for managing ventilation.
- Supply Temperature
- Return Temperature
- Return Humidity
- Return Dew Point
- Remote Dew Point
- Remote Temperature Average
- Remote Temperature Maximum
- Remote Temperature Minimum
- Remote Humidity
- Static Pressure
- Air Economizer Outdoor Temperature
- Air Economizer Outdoor Humidity
- Outdoor Temperature
- Glycol Temperature
- Airflow

The sensor reading changes colour according to the set alarm thresholds.





Color	Description
Green	The sensor reading is within the threshold limits.
Red	The sensor reading is above the threshold limits.
Blue	The sensor reading is below the threshold limits.
Grey	The sensor is either not enabled, the unit is OFF, or the threshold limits are not available for this type of sensor.

In the case of multiple sensors, these values represent the minimum, maximum, or average value based on the set method.

The utilization percentages of ventilation, cooling (DX or CW), Free Cooling, humidification, dehumidification, and heating are displayed on the lower side of the panel. The bar graph will be hidden if the option is not available.

ENGLISH

The shortcut icons on the right open panels directly, instead of browsing through menus:

Icon	Description
	Event Log menu
	Sensor Data menu
	Total Run Hours menu
	T/H Graphs

The secondary content panel on the right displays the list of active events (alarms or warnings) with corresponding dates and times. The 'Reset all' option sends a reset command for all active events.

1.2.1 Main Screen Customization

The  symbol is located in the upper-right corner of the main screen. This icon opens the customization menu, enabling the end-user to personalize the information displayed on the main screen.

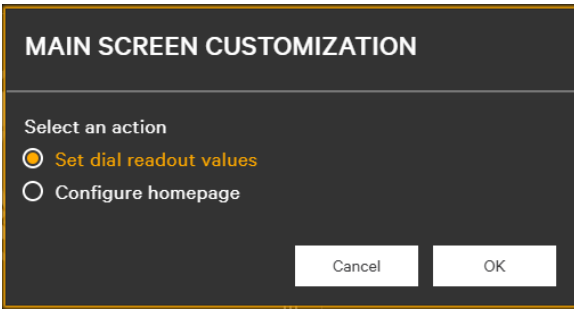

The option 'Set dial readout values' opens the 'Central Readout Configuration' mask, allowing the definition of what to display and what to hide in the center of the dial.

The 'Central Readout Configuration' mask can also be opened by pressing the dial for 2 seconds.

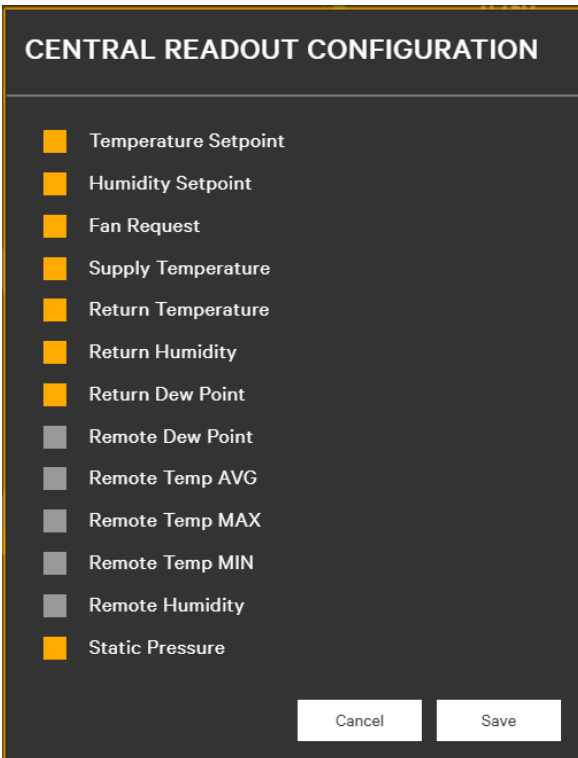

The option 'Configure homepage' allows to select between the standard homepage ('Dashboard'), the 'EconoPhase' view, the 'Unit Overview' or the 'System Overview'.

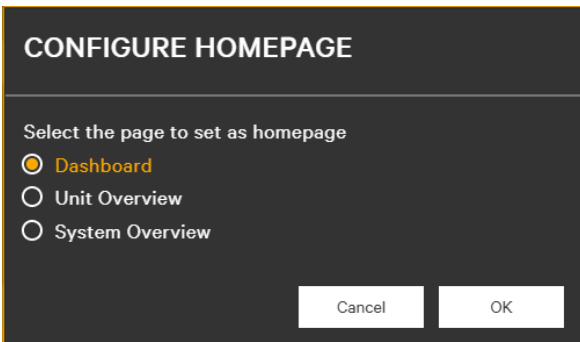

1.2.2 Searching

When logged-in, the user can select the 'Search' button to find the location of the control parameters in the HMI. In the control header, touch the 'Search' button.

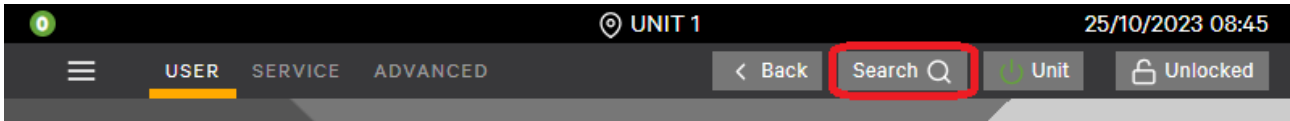

To search for a parameter, enter the full name or part of it (at least 3 letters) in the Search field. The Hints field provides suggestions for the full name of the parameter you are searching for. Select the desired one. The Search Results field lists all the menus containing that parameter. Press the 'GO TO' button to be directed to that menu.

The  icon indicates that the parameter is available and not hidden.

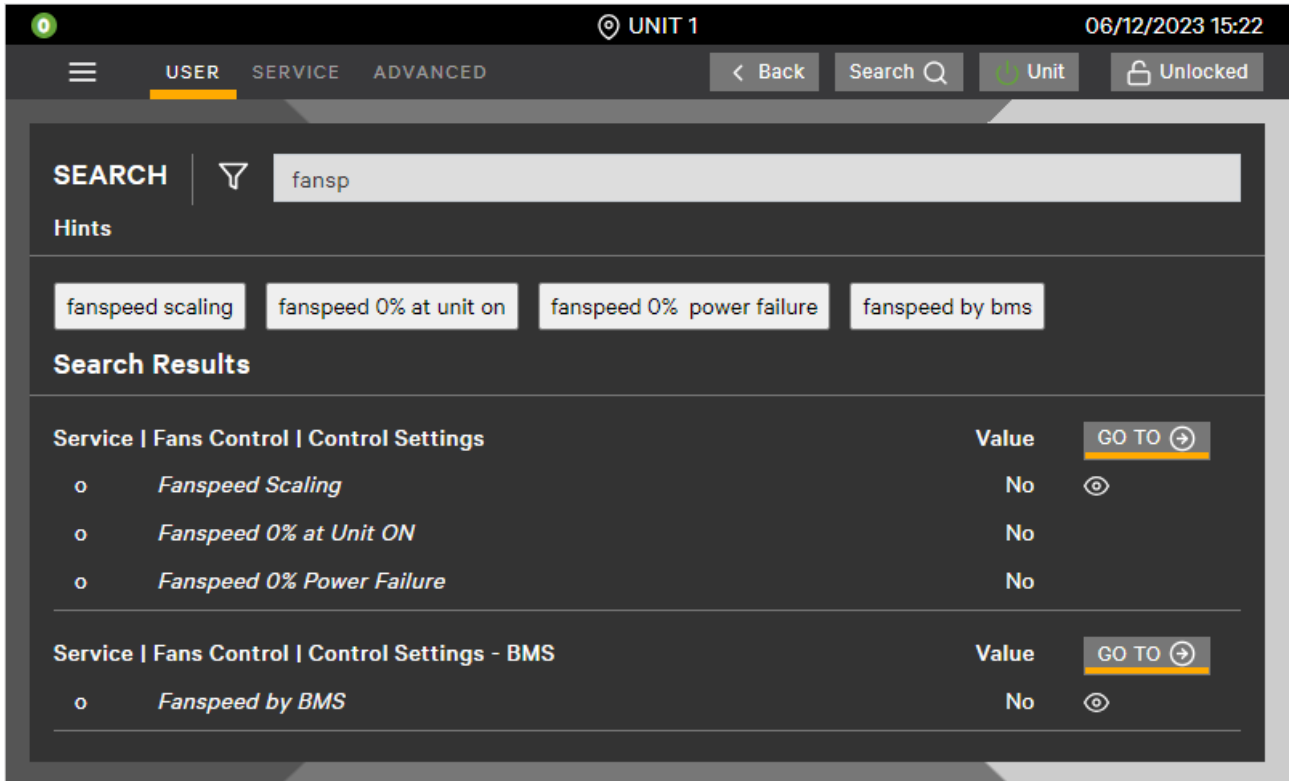

1.3 Event Detection

When the application detects a new local event, the following pop-up will be displayed:

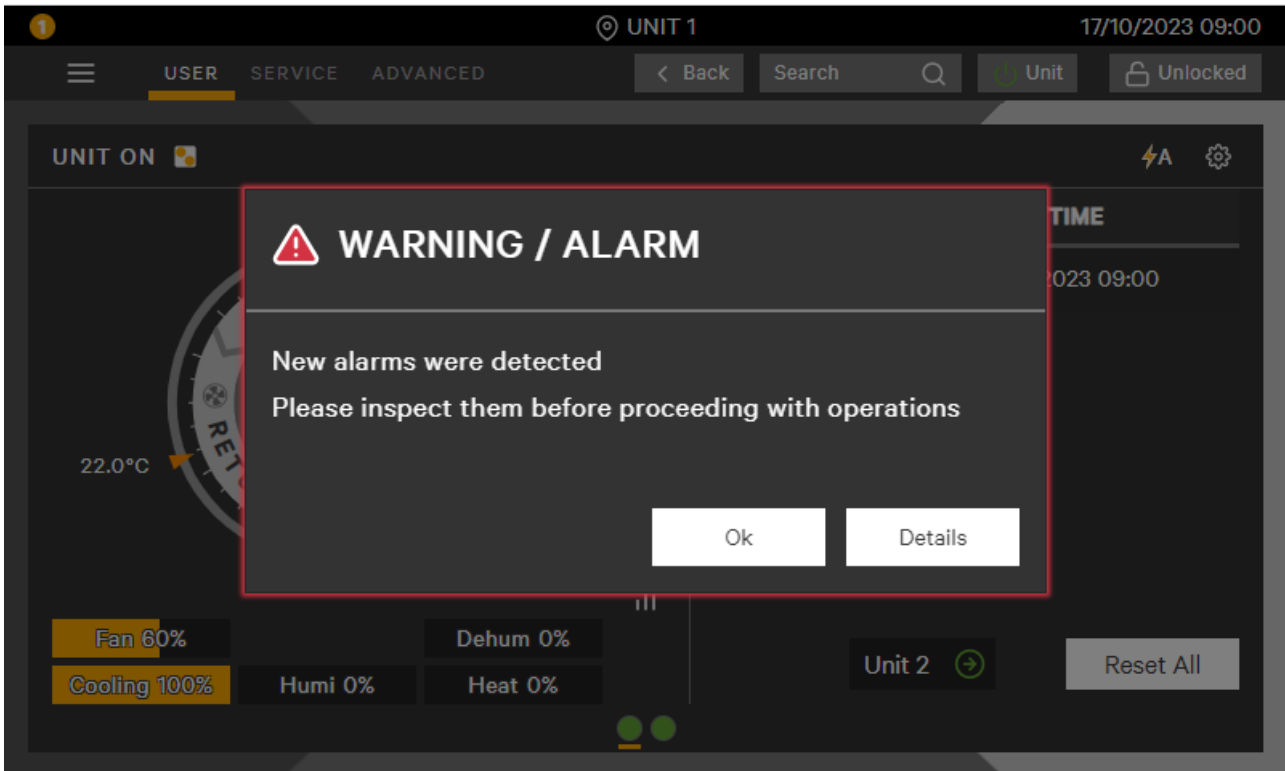

Clicking 'OK' will close the pop-up, while selecting 'Details' will open the Event Log menu.

When a new event is detected within one of the system units, the following pop-up will be displayed:

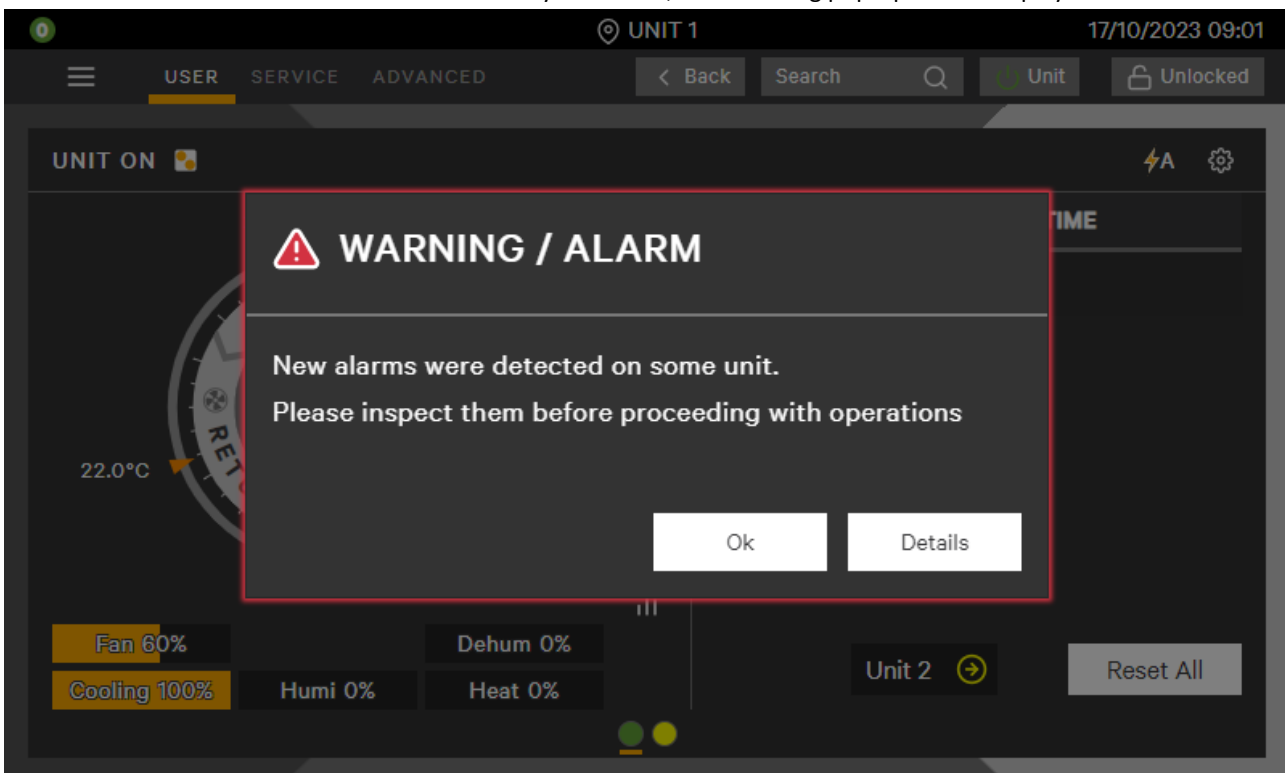

Clicking 'OK' will close the pop-up, while selecting 'Details' will open the System Overview menu. The pop-up will not appear if the 'System Events Banner' parameter (User/Display Options) is set to 'Not Active'.

1.4 Connections

A laptop, intended for service purposes, can connect to the main control board through the front door Ethernet connector only when the Touch Display is not installed. Refer to the schemes below for additional information.

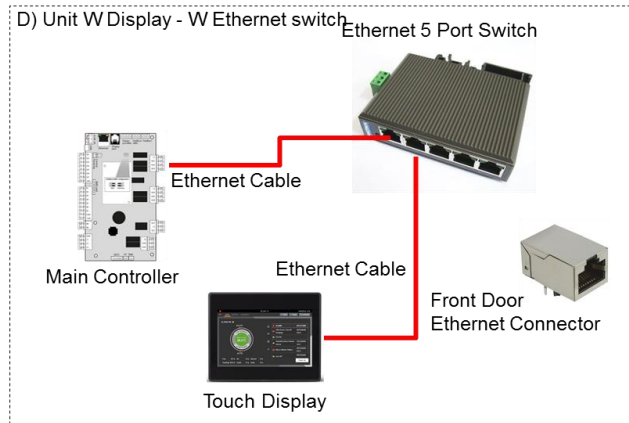
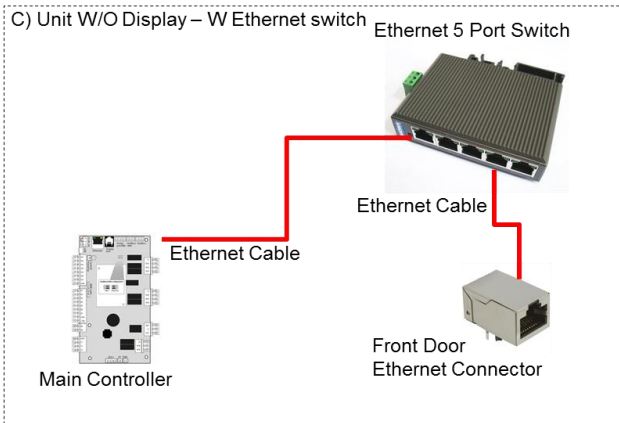
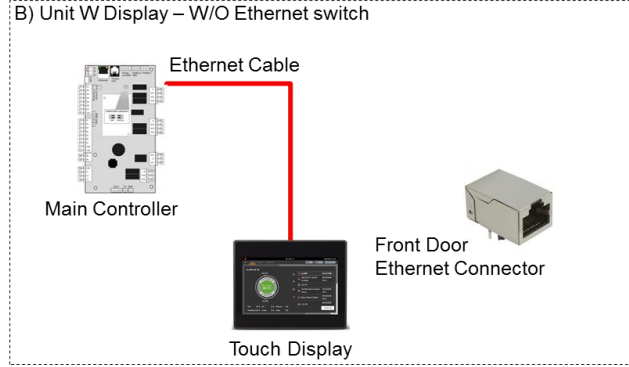
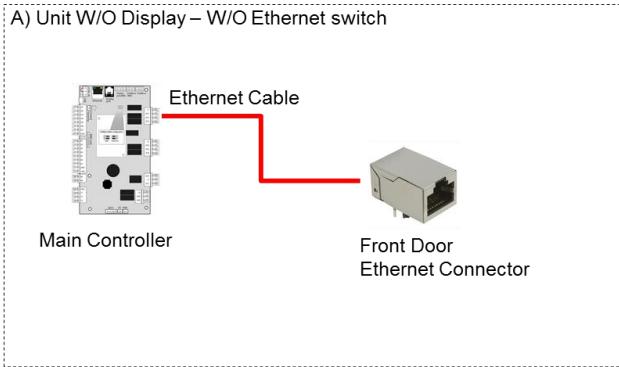

- **Configuration B ‘Unit W Display - W/O Ethernet switch’:** The laptop can be directly connected to the control board. To connect the laptop, disconnect the Touch Display Ethernet cable. There is only one Ethernet connector on the board.
- **Configuration D ‘Unit W Display - W Ethernet switch’:** The laptop can be directly connected to the switch. To connect the laptop directly to the front door connector, use an additional Ethernet cable (not supplied by Vertiv) from the Ethernet switch to the front door connector.

The connection error is displayed when the touch display loses communication with the main control board.

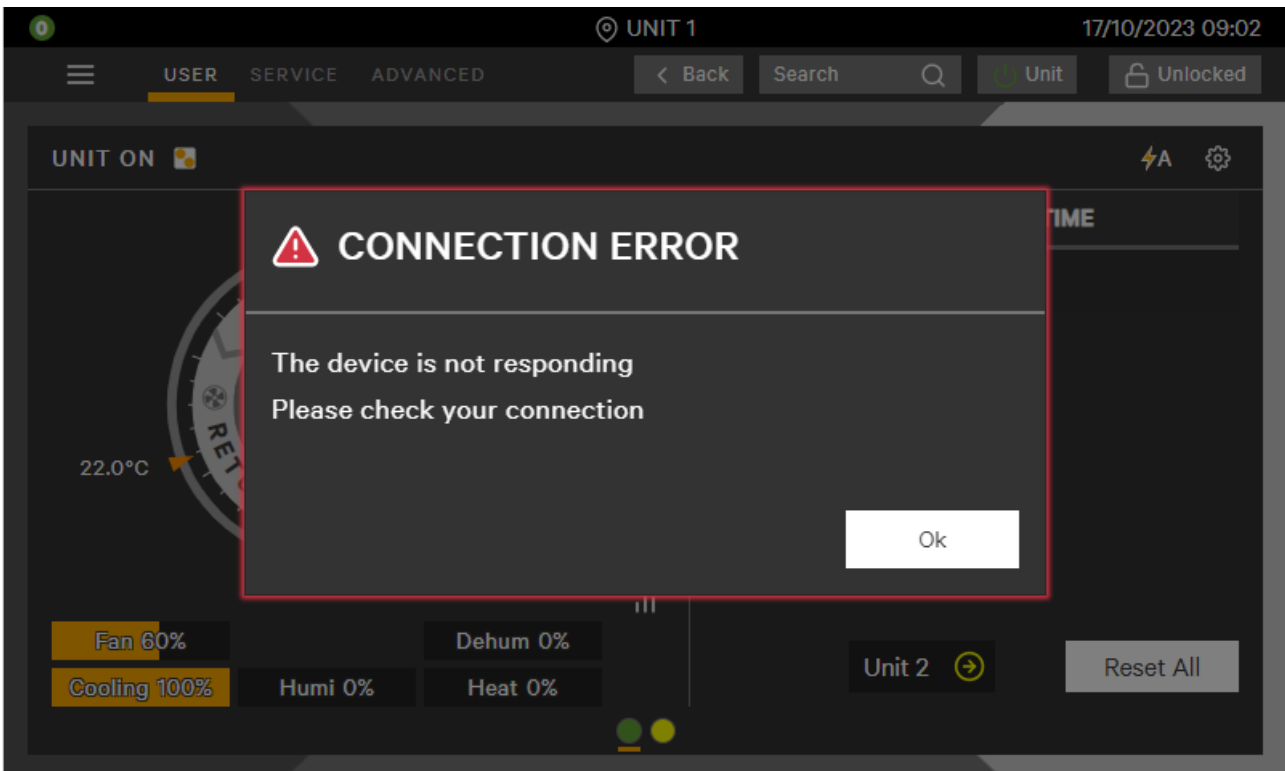

1.5 User Menu

Click on the User icon 'USER' and then press the '☰' button. The user options will be displayed in the drop-down menu.

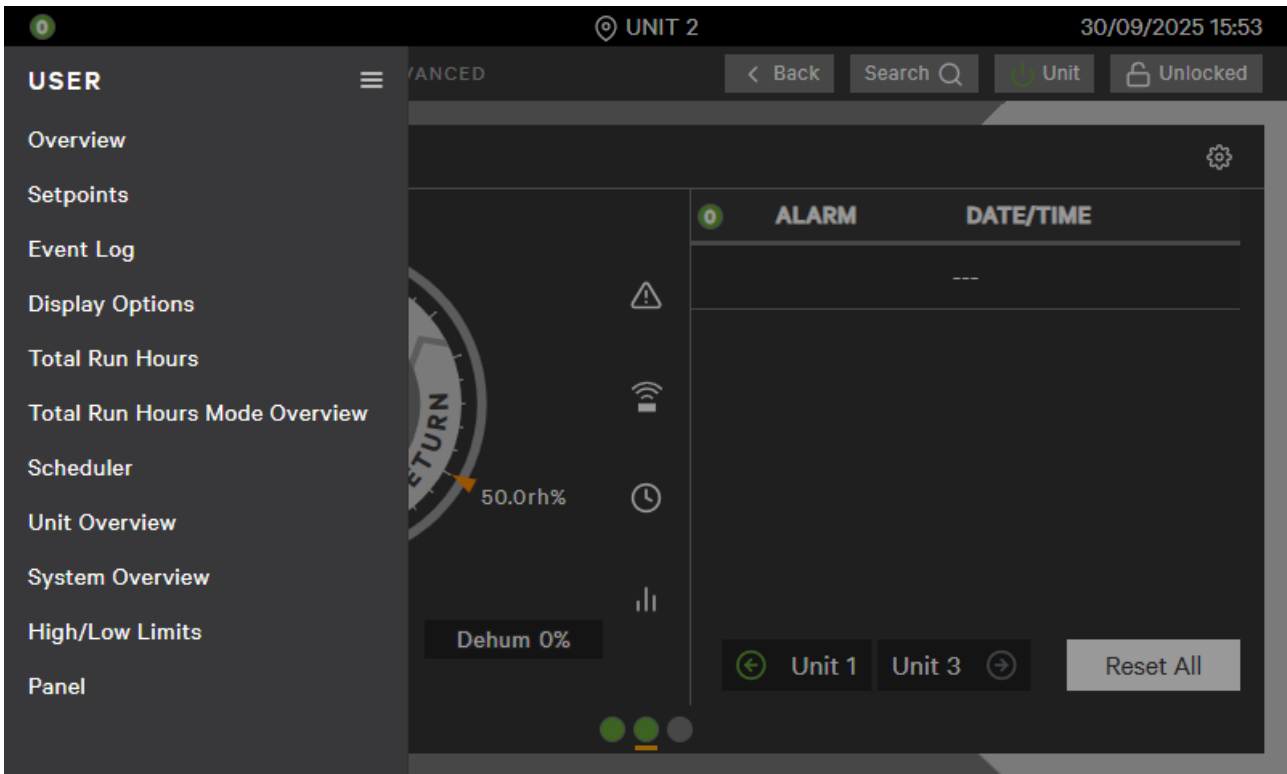

1.5.1 Setpoints

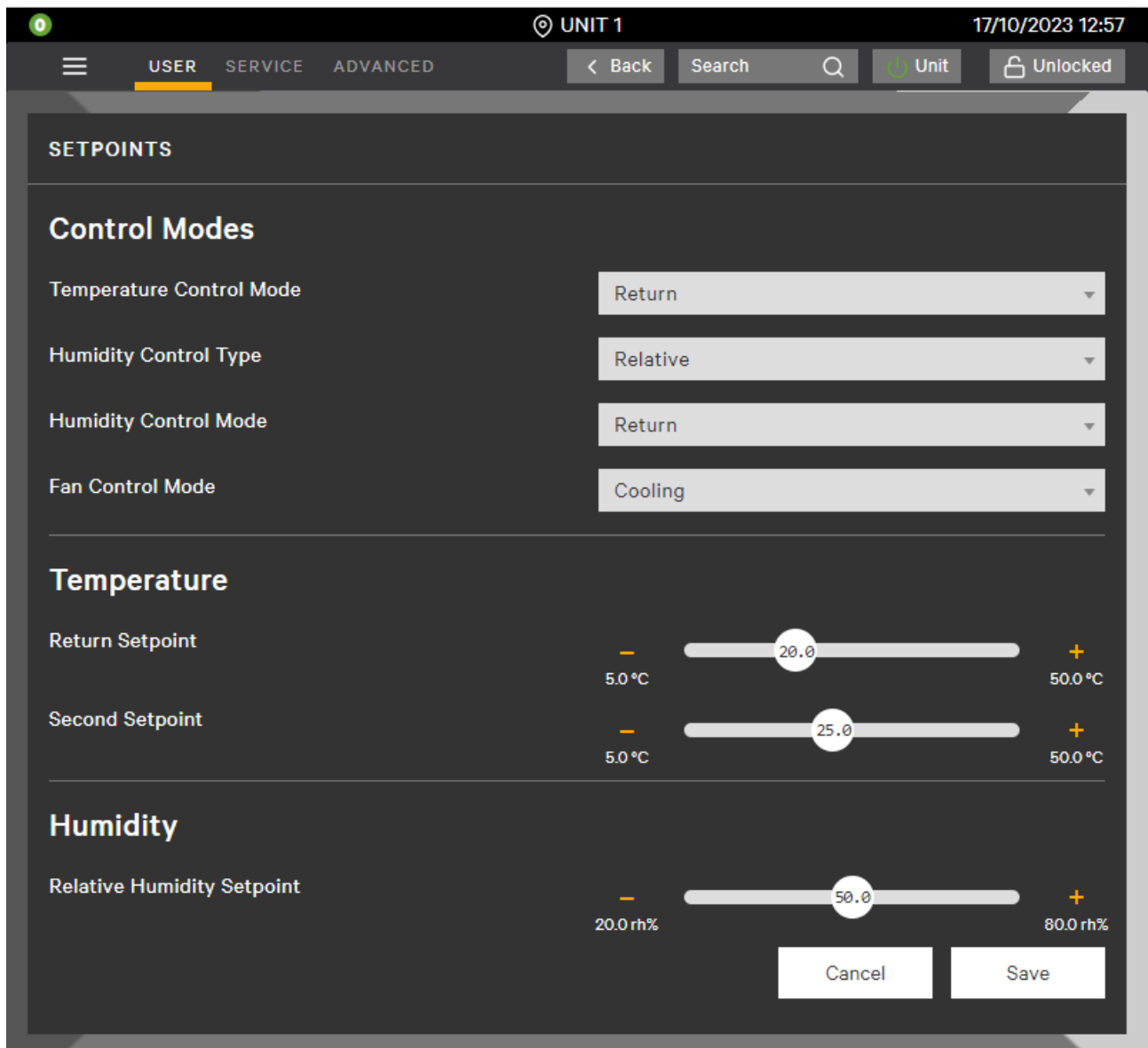

Control Modes

- Temperature Control Mode: This represents the desired method for temperature control. Options include 'Return', 'Supply', 'Return + Supply Limit', and 'Remote'.
- Humidity Control Type: This indicates the preferred humidity control type. Options include 'Relative', 'Relative Compensated', 'Absolute', and 'Dew Point'.
- Humidity Control Mode: This indicates the preferred humidity control method. Options include 'Return' and 'Remote'.
- Fan Control Mode: This represents the preferred method for fan control. Options include 'Return', 'Supply', 'Remote', 'Delta Return/Supply', 'Static Press', 'Ret CW Priority', 'Fixed', 'Cooling', and 'Delta Return/Remote'.

Temperature

- Return (or Supply or Remote) Setpoint: This represents the desired air temperature. The control system compares the measured value against the temperature setpoint to determine whether to activate cooling or heating.
- Second Setpoint: The second setpoint will be used instead of the standard temperature setpoint if one of the configurable inputs is set to '2nd Setpoint' and the corresponding input is active. When this occurs, the message 'Second Set Point Active' will be displayed.

Note: An additional Supply Setpoint will be displayed when the Temperature Control Mode is set to 'Return + Supply Limit'.

Humidity

- Relative (or Absolute or Dew Point) Humidity Setpoint: If the Humidity Control is enabled, this represents the desired humidity regulation value.

Note: An additional Fan Speed Control Setpoint will be displayed when the Fan Control Mode is set to anything other than 'Cooling'.

1.5.1.1 Temperature Control Mode

The Temperature Control Mode defines the sensor from which cooling and heating operations will be driven:

- Return
- Supply
- Return + Supply Limit
- Remote

Control Strategy

Cooling and heating devices are controlled based on the temperature deviation.

The proportional band defines the operating range for both cooling and heating. It is divided in two equal parts: the left side for heating and the right side for cooling. The control temperature setpoint is in the middle.

The dead band, which is equally divided between the negative and positive areas, shifts the negative and positive area apart.

The control temperature Integration, when set to any value, gradually adjusts the temperature deviation, even if the actual temperature remains stable. This allows for precise control. The Integral calculation stops and maintains its value when the actual proportional deviation falls within the dead band.

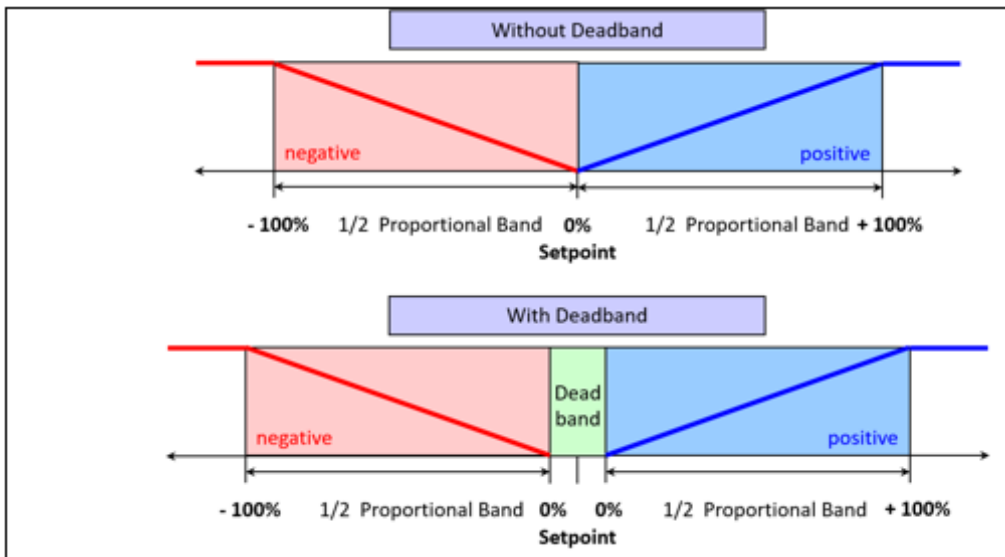

Return + Supply Limit

The control calculates two different temperature deviations; one based on return temperature and another one based on supply temperature. The value used to drive the chilled water valves, freecooling (air or water) and the compressor capacity will be the smaller of the two calculations.

Cooling begins to decrease at supply setpoint. The cooling request will be 0% when supply temperature reaches the supply setpoint - ½ proportional band.

This control method prevents excessively low supply temperatures.

Supply Limit is a local function; only local unit values (return temperature, supply temperature) are used to calculate it.

The supply limit shall reduce the cooling capacity, but not stop the compressor. If the supply temperature is lower than supply limit (Setpoint minus half Proportional Band), the compressors start will be not allowed.

Heating and fan speed are not affected by the supply limit.

1.5.1.2 Humidity Control Mode

The Humidity Control Mode defines from which sensor humidification and dehumidification will be driven:

- Return
 - Remote
- Supply is not supported.

The humidity control types are as follows:

- Relative
- Relative Compensated
- Absolute
- Dew Point

The control begins calculating the humidification/dehumidification request 10 minutes after the unit is turned on. Humidification can be enabled or disabled using the unit code (UC07). Dehumidification can be enabled or disabled through a dedicated parameter.

Relative Humidity Control

Humidification and dehumidification devices are activated based on the return or remote humidity deviation. The proportional band defines the operational range for both humidification and dehumidification. It is divided in two equal parts: the left side for humidification and the right side for dehumidification. The humidity setpoint is located in the middle.

The dead band, which is equally divided between the negative and positive areas, shifts the negative and positive area apart.

The humidity integration, if set to a specific value, gradually adjusts the humidity deviation, even when the actual humidity remains stable. This allows for fine control precision. The integral calculation stops and maintains the same value if the proportional deviation falls within the dead band.

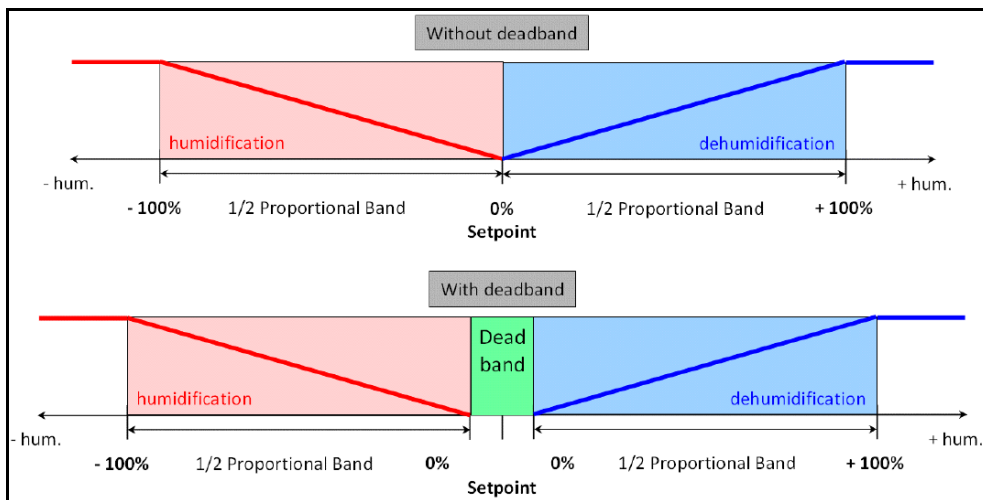

Relative Compensated Humidity Control

The return or remote humidity setpoint will be adjusted based on the current deviation from the temperature setpoint. For every 1 Kelvin deviation from the temperature setpoint, the humidity setpoint will be modified by 3% relative humidity.

In the case of a temperature increase, the humidity setpoint will be decreased, and vice versa (indirectly proportional). The recalculated setpoint will be displayed as the current humidity setpoint. Simultaneously, the humidity thresholds (high/low humidity) will be internally recalculated.

Absolute Humidity Control

The control applies the same logic strategy as with relative humidity, but it uses the calculated absolute humidity value.

All the related parameters (setpoint, proportional band, dead band, high/low thresholds) are displayed in grams per kilogram (g/Kg) instead of percentage (%).

Dew Point Control

The control applies the same logic strategy as with relative humidity, but it uses the calculated Dew Point value.

All the related parameters (setpoint, proportional band, dead band, high/low thresholds) are displayed in Celsius (°C) or Kelvin (K) instead of percentage (%).

1.5.1.3 Fan Control Mode

- Return: The fan speed is modulated from the minimum to the maximum speed set following the return temperature deviation.
- Supply: The fan speed is modulated from the minimum to the maximum speed set following the supply temperature deviation.
- Remote: The fan speed is modulated from the minimum to the maximum speed set following the remote temperature deviation.
- Delta Return/Supply: The speed of the evaporating fans is modulated to maintain a constant delta T between return temperature and supply temperature. When the delta T falls within the dead band, the fan speed remains unchanged. When the delta T goes beyond the dead band, the control adjusts the fan speed (increasing or decreasing) to bring the delta T back within the dead band.
 - If the delta between return temperature and supply temperature is lower than the delta setpoint, the fan speed will decrease.
 - If the delta between return temperature and supply temperature is higher than the delta setpoint, the fan speed will increase.

This functionality is not available in Teamwork Mode 1 and 3.

The current fan speed request persists after a unit restart. When the unit starts and is beyond the fan start speed duration, the control will apply the stored speed.

- Static Pressure: The speed of the evaporating fans is modulated to maintain constant the static pressure. When the pressure falls within the dead band, the fan speed remains unchanged. When the pressure goes beyond the dead band, the control adjusts the fan speed (increasing or decreasing) to bring the pressure back within the dead band.
 - If the pressure is lower than the Setpoint band, the fan speed will increase.
 - If the pressure is higher than the Setpoint band, the fan speed will decrease.

In Teamwork Mode 1 and 3 all units will use the system pressure value calculated by the primary unit. The 'DP is based on' parameter determines whether the control uses the average value (default setting) or the minimum value of the system. The 'Teamwork is based on' parameter setting is disregarded by the control for this function.

The current fan speed request persists after a unit restart. When the unit starts and is beyond the fan start speed duration (reduced to 5 seconds), the control will apply the stored speed.

- Return CW Priority: The CW valve modulates between 0% and 50% of the call for cooling based on return temperature. The Fan speed modulates between 50% and 100% of the call for cooling based on return temperature. This means the fan starts modulating only when the CW valve is fully open.
- Fixed: During normal operation, the fan operates at the set fixed speed. The fan speed can be overridden due to predefined working conditions (if higher) or for unit safety reasons.
- Cooling: The Fan speed will follow the same strategy (PI) used for the temperature control (coupled mode).
- Delta Return/Remote: The speed of the evaporating fans is modulated to maintain a constant delta T between the return temperature and remote temperature. When the delta T falls within the dead band, the fan speed remains unchanged. When the delta T goes beyond the dead band, the control adjusts the fan speed (increasing or decreasing) to bring the delta T back within the dead band.
 - If the delta between Return and Remote temperatures is lower than the delta setpoint, the fan speed will decrease.
 - If the delta between Return and Remote temperatures is higher than the delta setpoint, the fan speed will increase.

In Teamwork Mode: The 'DT is based on' parameter determines whether the Delta Temperature value used by the control is the average value (default setting) or the maximum value of all DTs in the system. The setting of the 'Teamwork is based on' parameter is disregarded by the control for this function.

The current fan speed request persists after a unit restart. When the unit starts and is beyond the fan start speed duration, the control will apply the stored speed.

1.5.2 Event Log

The Event Log displays the most recent 200 events, including alarms, warnings, and messages, that occurred on the unit. It provides information such as start time, stop time, and dates for each event.

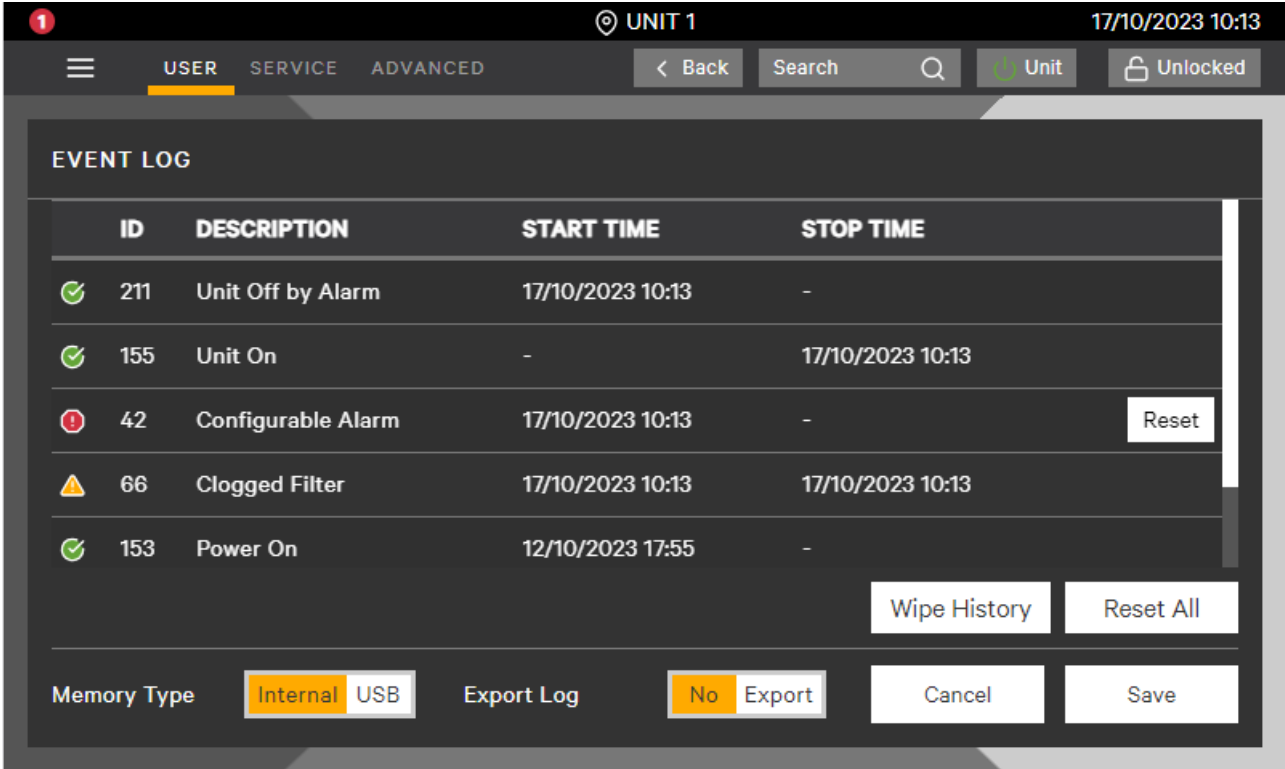

- Reset: Allows the reset of a single active event.
- Wipe History: Cancels the list of alarms, warnings, and messages. A confirmation pop-up is required to delete the event log history (for service purposes only).
- Reset All: Sends a reset command to all active events.
- Memory Type: Specifies where to download the events log, Internal Memory or USB (for service purposes only).
- Export Log: The command to download the events log (for service purposes only).

The following symbols are used to identify different event types:

Icon	Description
	Alarm
	Warning
	Message

Some events have additional information that can be viewed by pressing the button on the right side.

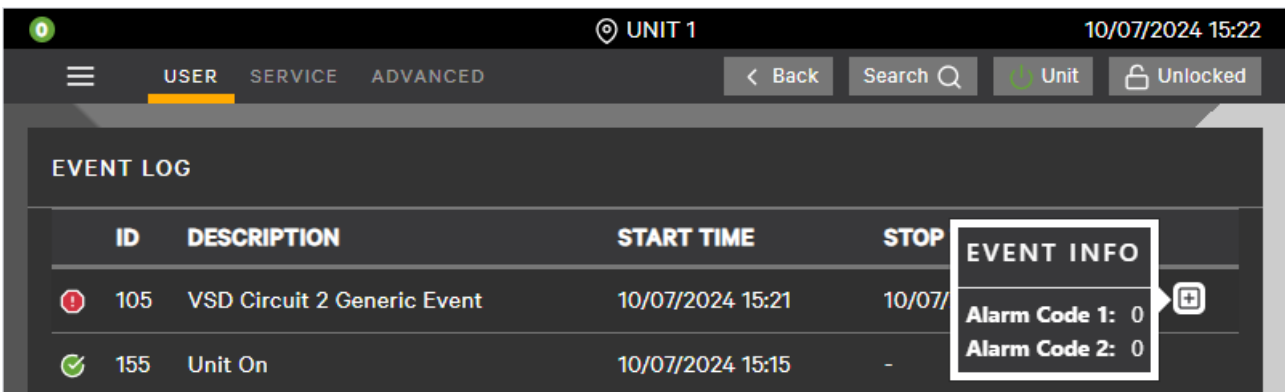

1.5.3 Display Options

This menu defines the following:

- Language: English, Italiano, Deutsch, Francais, Espanol, Türk, Polski, Český, Portugues, Russkiy, Nederlands and Slovenčina.
- System of Measurement: Matric or Imperial.
- Date: Year [YY], Month [MM] and Day [DD].
- Date Format: dd/MM/yyyy (Day/Month/Year) or MM/dd/yyyy (Month/Day/Year) or yyyy-MM-dd (Year-Month-Day) or dd.MM.yyyy (Day.Month.Year) or yyyy/MM/dd (Year/Month/Day).
- Time: Hours and Minute.
- Time Format: 24h or 12h AM/PM.
- Skin: Defines the background color as either Dark or Light.
- Unit Name: Allows to change the name displayed on the unit on screen top bar (default name = Unit). The maximum length can be 12 characters. Note: '#' is not allowed.
- Outer Dial Value Type: Defines what to show on the outer dial, Sensor readings or Setpoints.
- Alarm Buzzer Pattern: Defines the buzzer frequency, including options like Silent (disabled), Two Tone, Constant High Pitch, Constant Low Pitch, Intermittent High Pitch, and Intermittent Low Pitch.
- System Events Banner: The system events pop-up will not be displayed if the parameter is set to 'Not Active'.
- Session Timeout [min]: Defines the time, based on the last touch, after which the session ends, and the user will be automatically logged out.
- Backlight Timeout [min]: Defines the time, based on the last touch, after which the backlight is turned off.

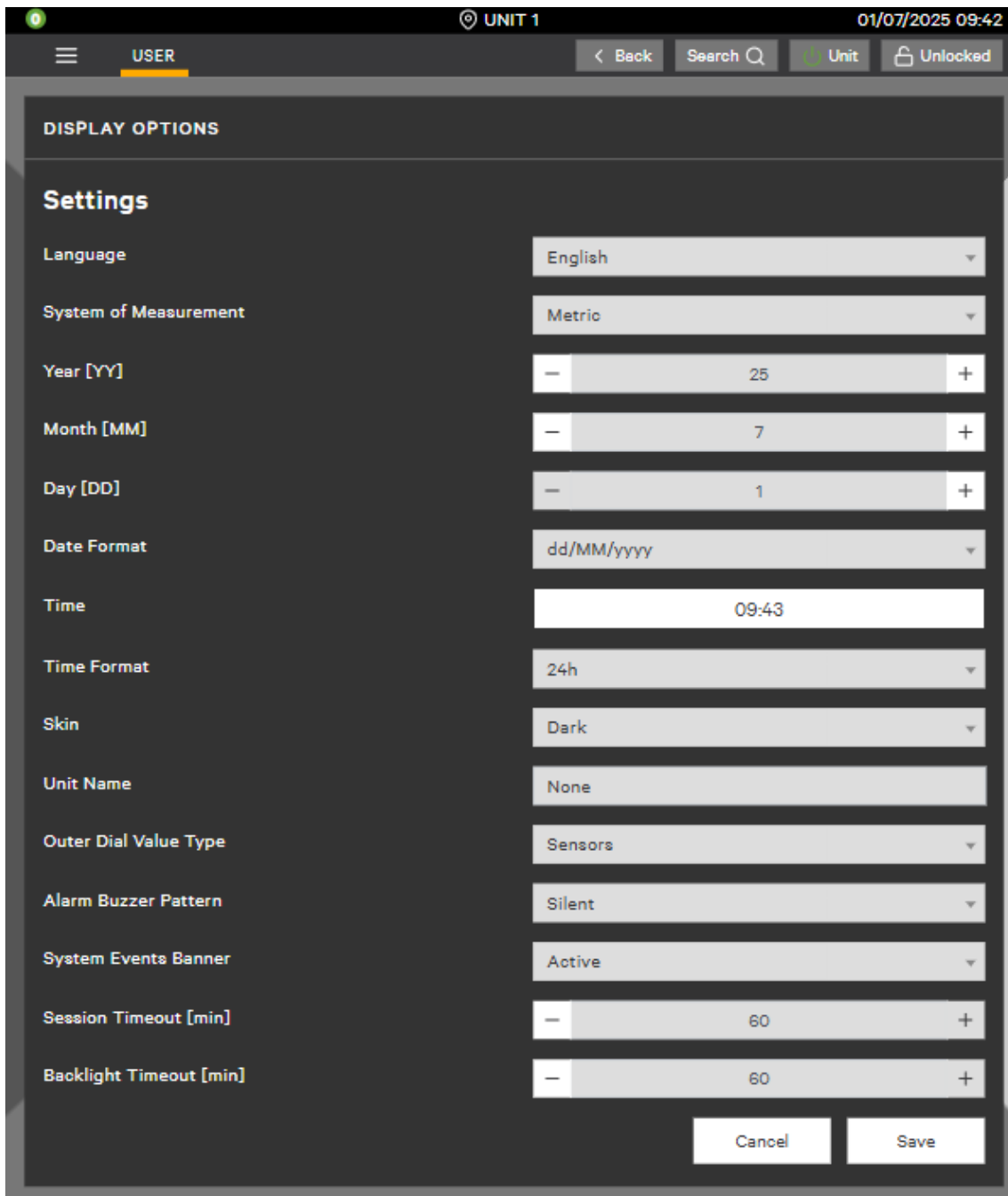

1.5.4 Total Run Hours

This menu displays the current run hours counter (first column) and the adjustable limit (second column) for the main components.

If the operating hours exceed this limit, the corresponding working hours exceeded event will be triggered.

Setting the limit to 0 ensures that the event will never be generated.

The actual run hours can be reset to 0 by clicking on the actual hours field and then clicking 'Save'.

Component	Current Run Hours	Adjustable Limit
Fan Motor	90	0
Comp1 C1	84	0
Free Cooling	75	0
Condenser 1	84	0
Humidifier	10	0
Dehumidification	12	0
Heater 1	2	0
Heater 2	2	0
EEV 1	84	0

Buttons: Cancel, Save

1.5.5 Total Run Hours Mode Overview

This menu provides an overview of the overall runtime and displays the run hours for various operating modes, including mechanical cooling, freecooling, and simultaneous mode.

There are no set thresholds for these counters.

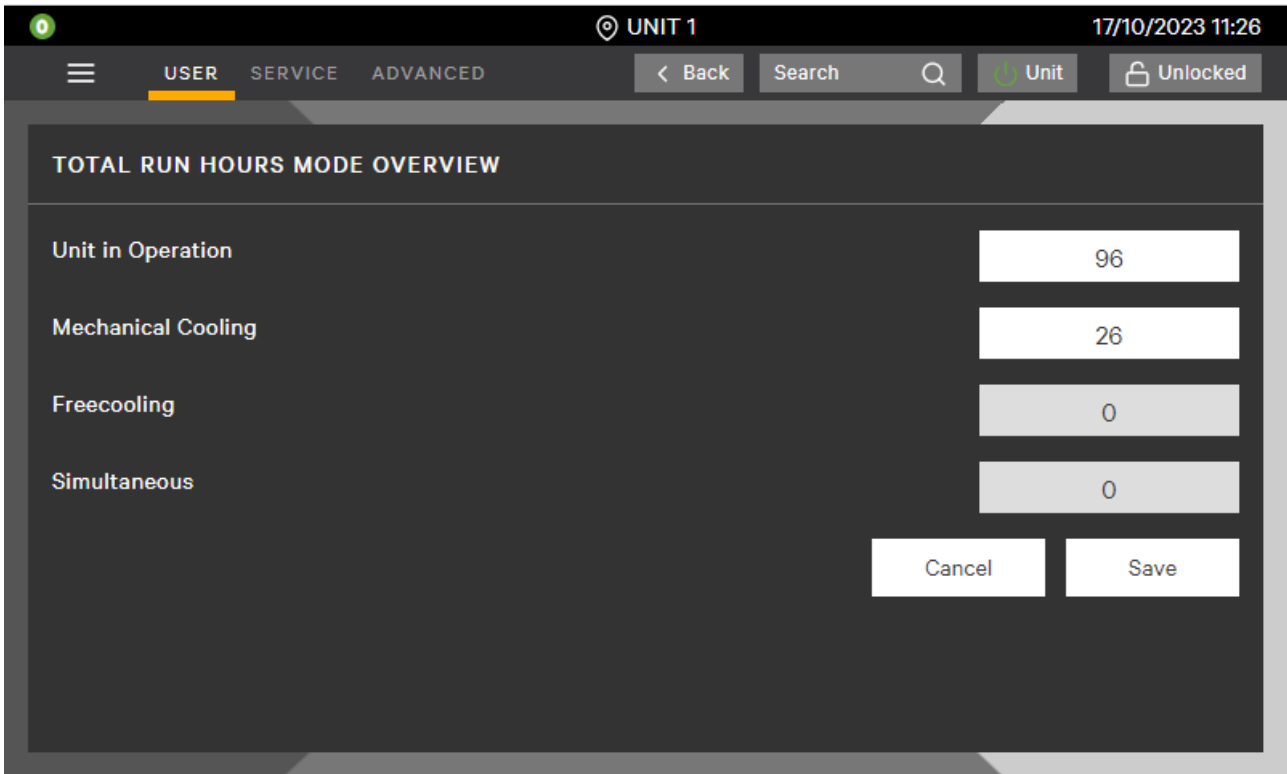

1.5.6 Scheduler

The scheduler empowers the end-user to activate Sleep Mode for the unit according to specific days and times.

Once enabled, the option for a full day of sleep (Always Off) or two sleep intervals (Band, followed by Time Band 1 or Time Band 2) per day is available.

When the specified time of day (or the entire day) is reached, the unit enters Sleep Mode, displaying the status 'Timer OFF' and the message 'UNIT OFF BY TIMER'.

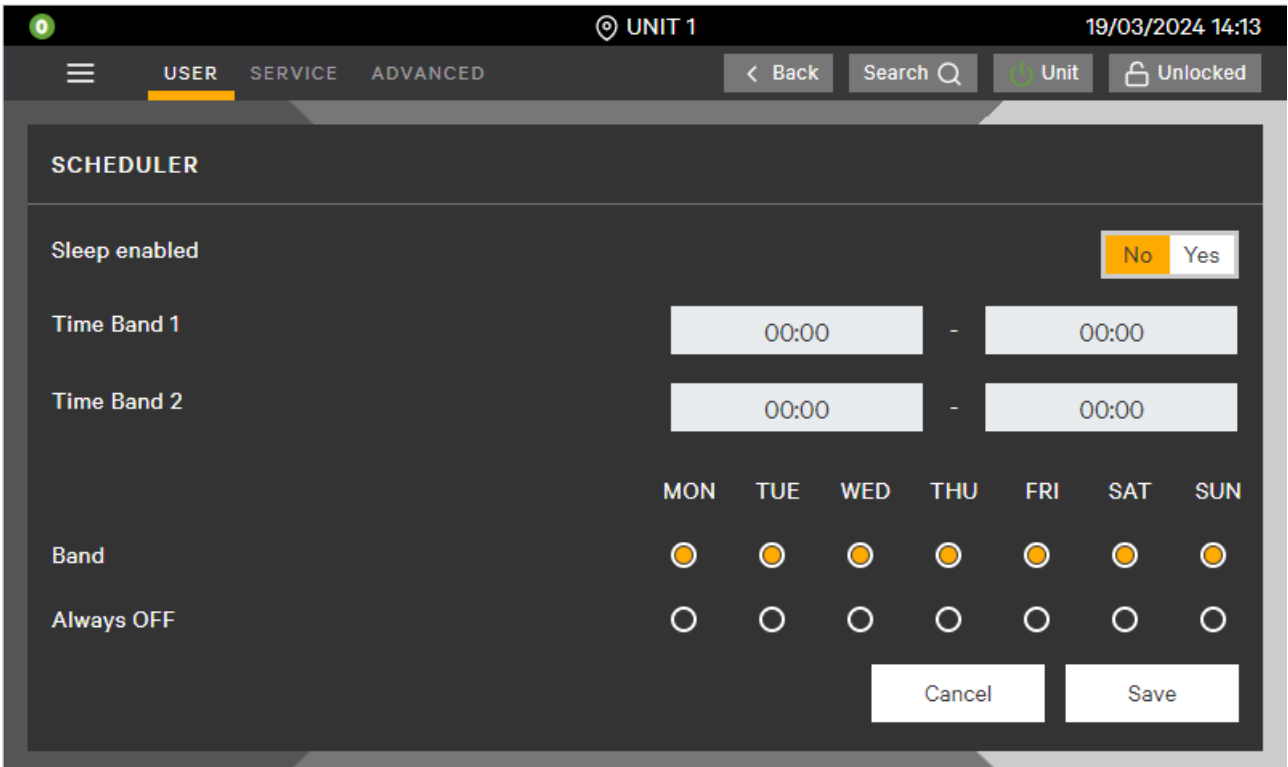

1.5.7 Condenser (DX Air Cooled only)

Low Noise Mode is designed to limit the maximum speed of the condenser fans, effectively reducing noise. Once activated, it allows for a full day (Whole Day) or up to two intervals (Band, followed by Time Band 1 or Time Band 2) to be set. During these intervals, the condenser will operate in Low Noise Mode.

Low Noise Speed: Specifies the maximum condenser fan speed when in Low Noise Mode.

Low Noise OK: Sets the pressure threshold; if the actual pressure falls below this threshold, Low Noise Mode is permitted to start.

HP Threshold: Halts Low Noise Mode if the actual pressure is at or above the specified threshold. In such cases, the 'Low Noise Speed' setting is ignored, and the condenser control returns to normal operation.

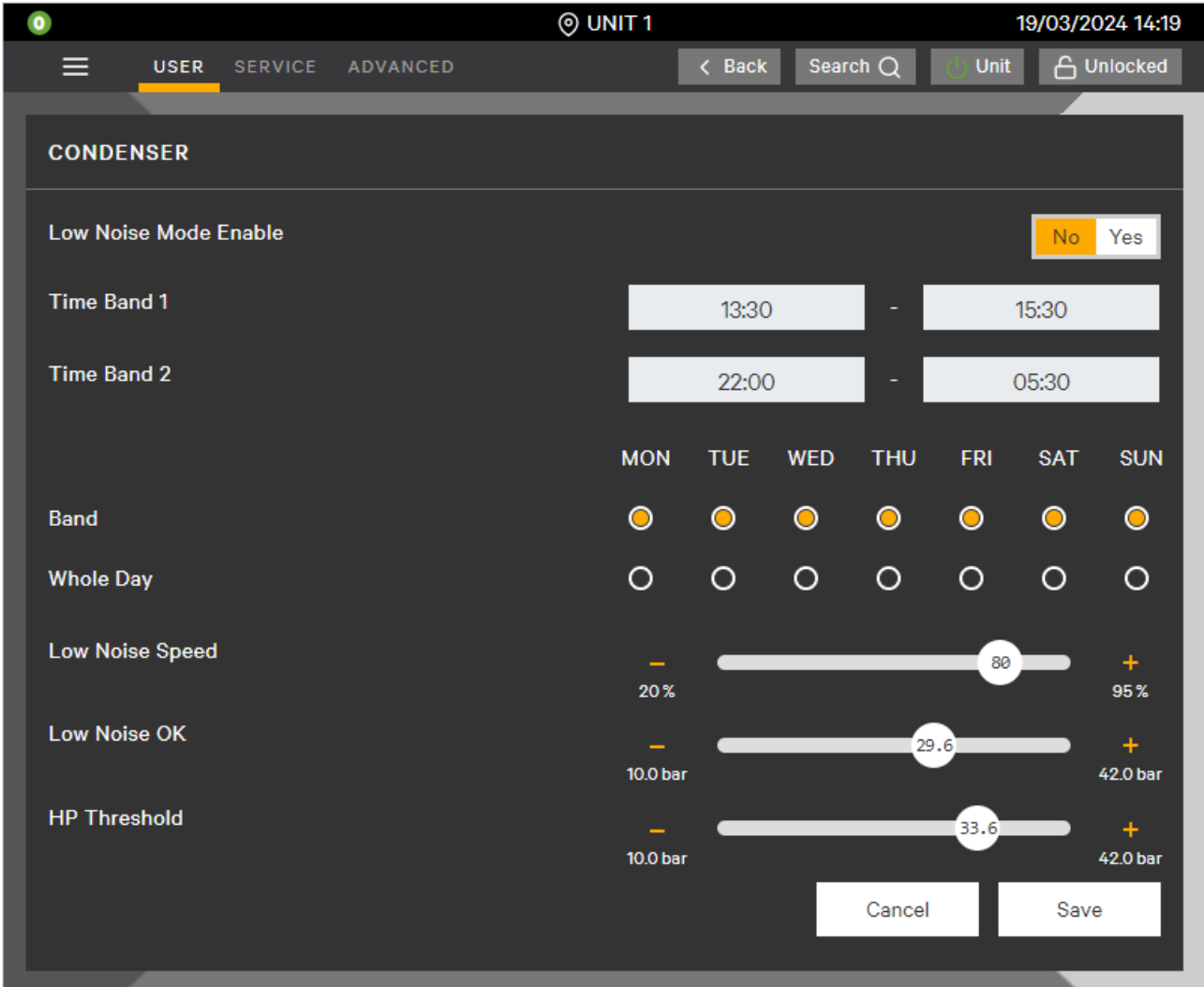

1.5.8 Unit Overview (CW)

This menu shows the evaporator fan speed and cooling request. Animated icons indicate the status of those devices in the unit, including CW inlet temperature, CW outlet temperature, water flow rate, and the feedback value (if available).

Return temperature, return humidity, and supply temperature are displayed at the bottom of the page.

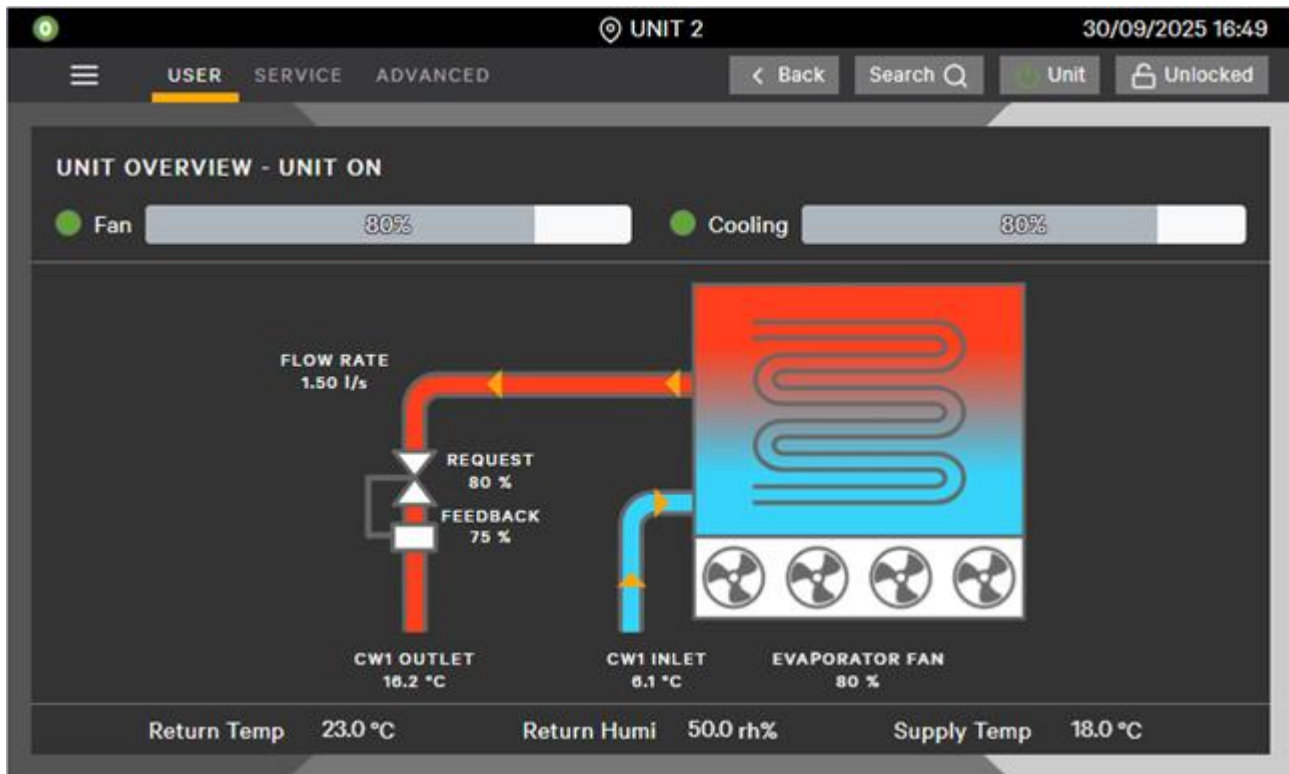

1.5.9 Unit Overview (DX)

This menu shows the evaporator fan speed, cooling request and freecooling request (if available). Animated icons indicate the status of these devices in the unit, including the condenser fan speed or valve opening.

Return temperature, return humidity, and supply temperature are displayed at the bottom of the page.

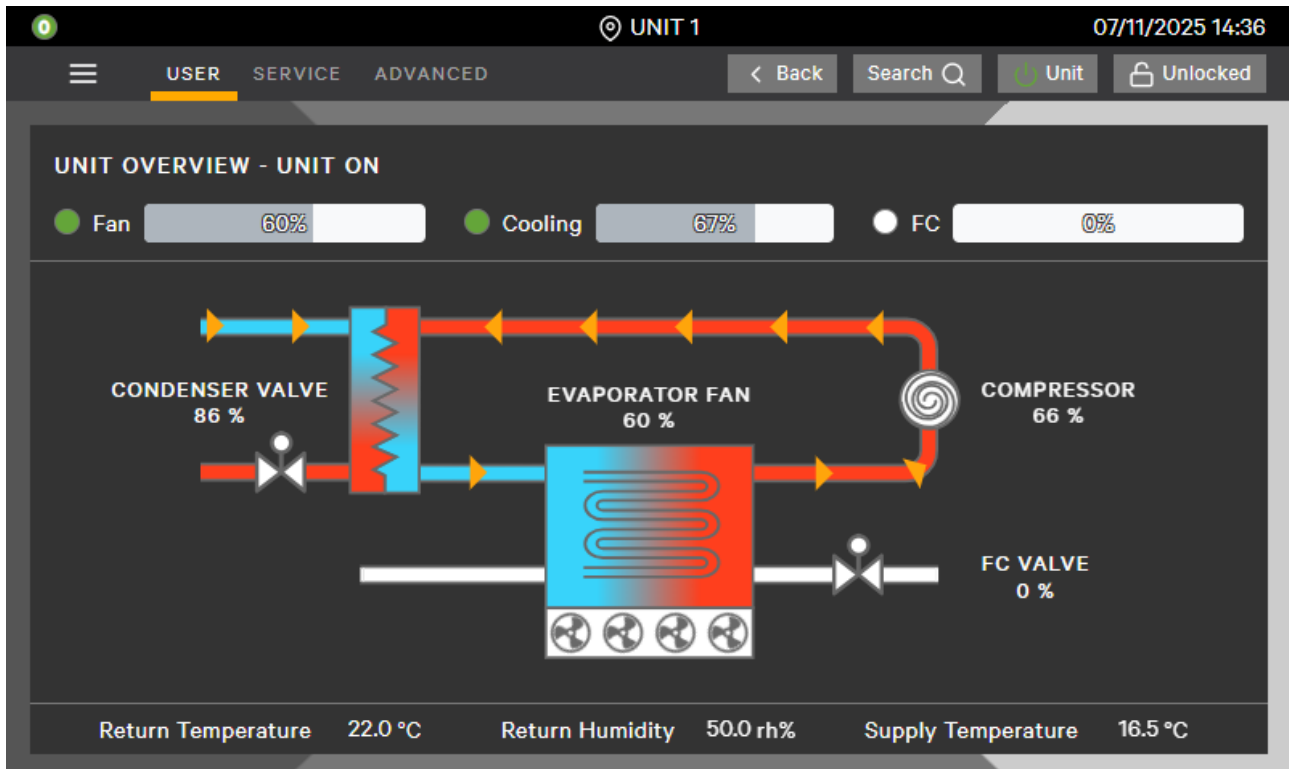

1.5.10 System Overview

The System On/Off command is disabled by default. If enabled the entire system can be switched on or off by adjusting the position of the System On/Off button.

In Teamwork Mode 0 (No Teamwork) and without standby units, the System On/Off command will not have any effect on the units.

Note: When the system is turned on, the units will maintain the same status as before the System Off command.

The System Overview includes:

- The system percentage utilization of fans (Fan), free cooling air or water (FC), compressor or CW valve (Cool) and heating (Heat). Additionally, it provides the system percentage deviation of humidification (Humi) and dehumidification (Dehum) when active.
- The current system setpoint for temperature and humidity. Note that in Teamwork Mode 0 (No Teamwork), these values should not be considered.
- System values for return temperature, return humidity, supply temperature, remote temperature, and remote humidity.
- If the AAT function is enabled, the 'Auxiliary Aggregated Temperature' (AAT) value and the 'Teamwork Aggregated Control Temperature' (TWACT) value will be displayed.

The navigation panel on the right shows the status of the units in the system and enables navigation from one unit to another by pressing the corresponding button.

The screenshot displays the 'SYSTEM OVERVIEW' for 'UNIT 1' on '24/10/2025 09:09'. The interface includes a navigation bar with 'USER', 'SERVICE', and 'ADVANCED' tabs, and a top right area with 'Back', 'Search', 'Unit', and 'Unlocked' buttons. The main content is divided into two panels. The left panel shows system utilization metrics: Fan 56%, Cool 46%, Dehum 0%, FC 0%, Heat 0%, and Humi 0%. Below these is a 'System On/Off' toggle set to 'On'. A table displays temperature and humidity values for Setpoint, Return, Supply, and Remote. The right panel shows a navigation list for units U01 and U02, both marked as 'Unit On'.

	Setpoint	Return	Supply	Remote
Temp	20.0 °C	22.3 °C	17.6 °C	19.9 °C
Humi	50.0 rh%	50.7 rh%		51.3 rh%

1.5.11 EconoPhase

Note: The EconoPhase menu will be hidden if the EconoPhase option is not selected.

EconoPhase operation saves energy by suspending compressor operation when outdoor ambient temperatures are sufficiently cool or when the temperature difference between indoor and outdoor ambient environments is met.

This menu indicates the system operating mode: Compressor mode, EconoPhase mode, or Mixed mode. Animated icons display the status of each device in the system, including pumps, compressors, condensing fans, and evaporating fans.

Return temperature, supply temperature, remote temperature (if available), and outdoor temperature are displayed at the bottom of the page.

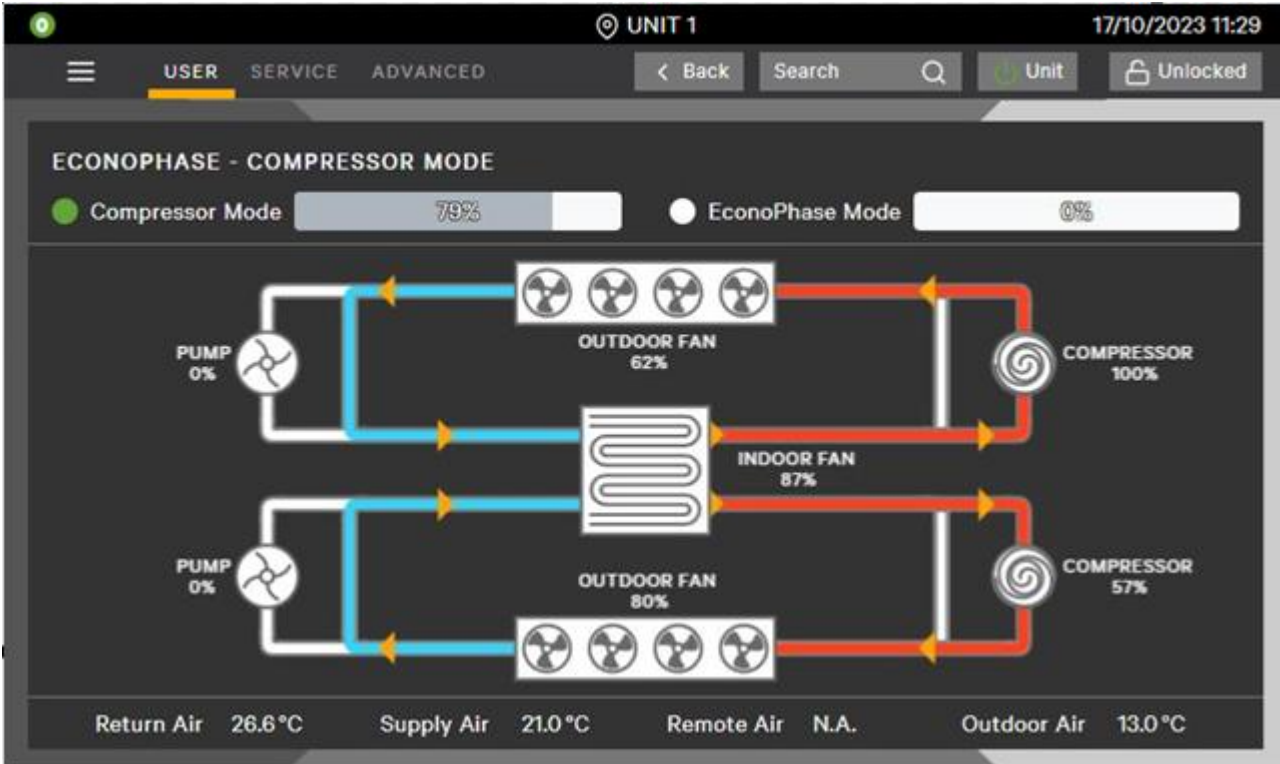

1.5.12 High/Low Limits

These three menus (Return Sensor, Remote Sensor, and Supply Sensor) allow users to enable and set high and low thresholds for the following:

- Return Temperature
- Remote Temperature
- Supply Temperature
- Return Humidity
- Remote Humidity

When enabled, if the actual value exceeds the specified boundaries for 30 seconds, the corresponding event will be triggered. All these events (auto-reset) are disregarded when the unit is turned on for the duration set by the 'Initial Time Delay' parameter.

The Remote Sensor and Supply Sensor menus are hidden if the remote and supply sensors are not enabled.

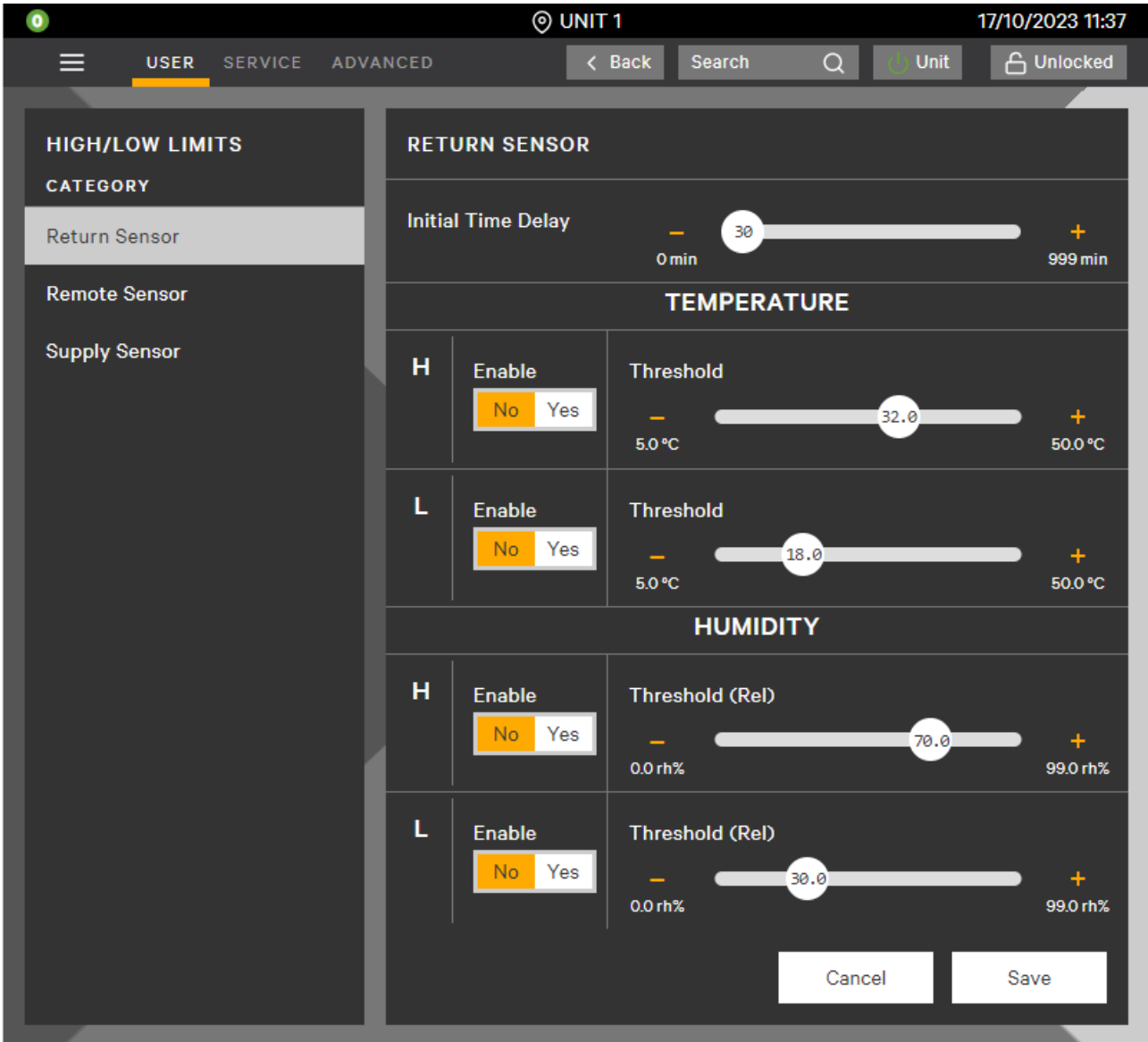

Additional menu is displayed when the static pressure sensor is enabled.

1.5.13 Panel

This menu emulates the Small Display, replicating its functionality and features.

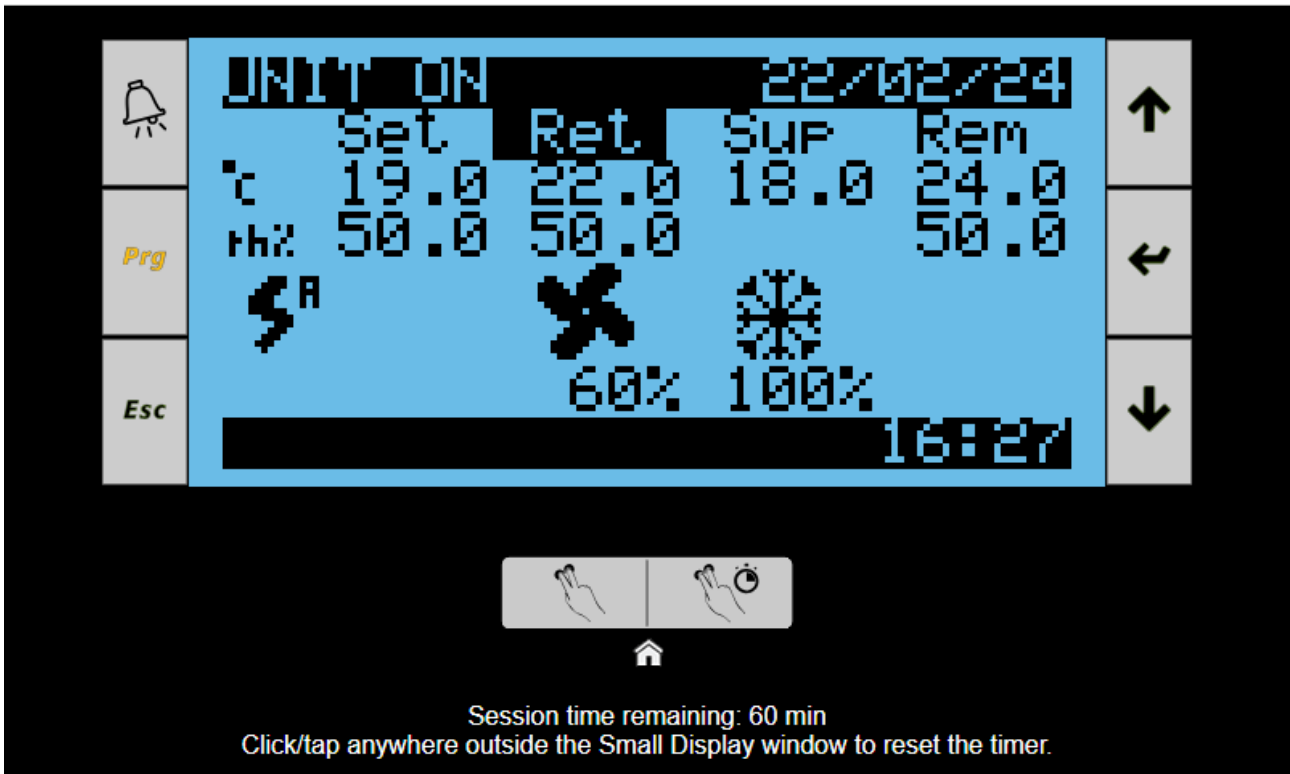

Press the Home  button to return to the main page.

1.6 Overview (Unit)

Select the User icon 'USER' and then press the '☰' button, followed by Overview. The overview options will be listed in the drop-down menu.

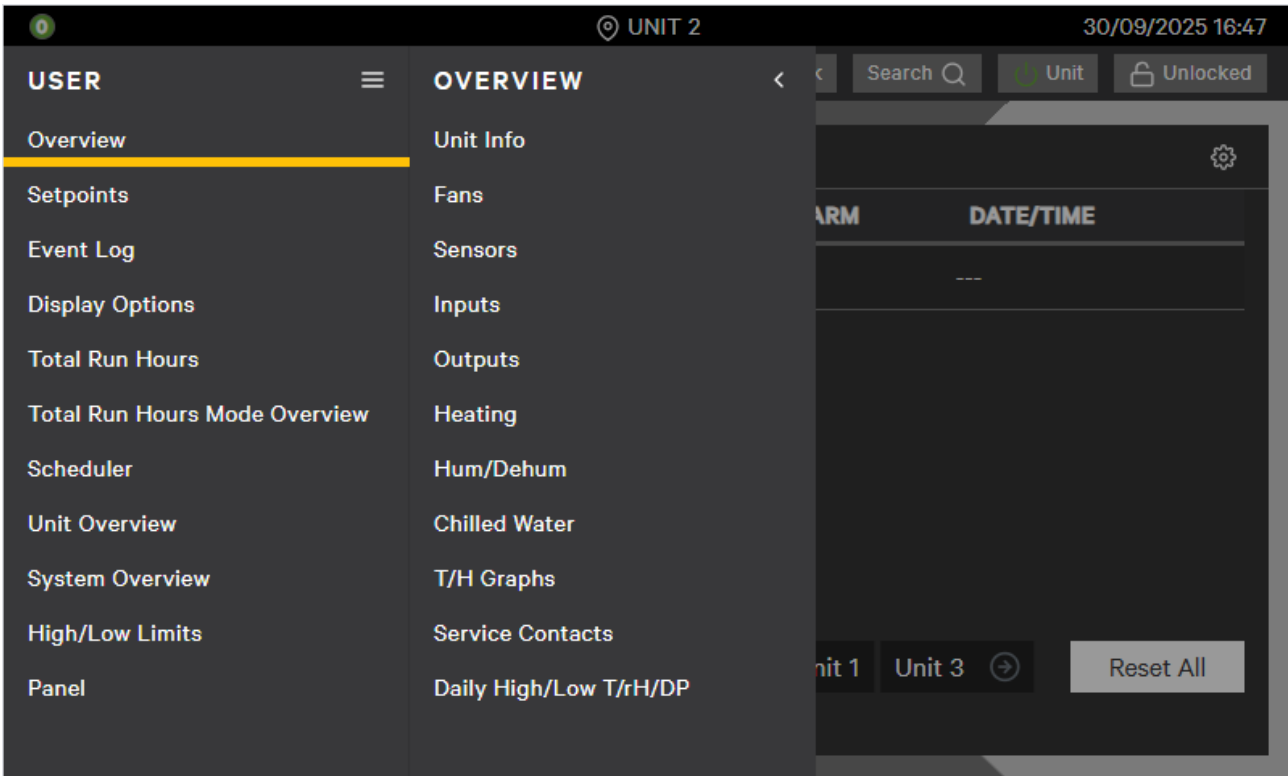

1.6.1 Unit Info

The Unit Info menu displays the software version and the operating system version installed on the unit's main board.

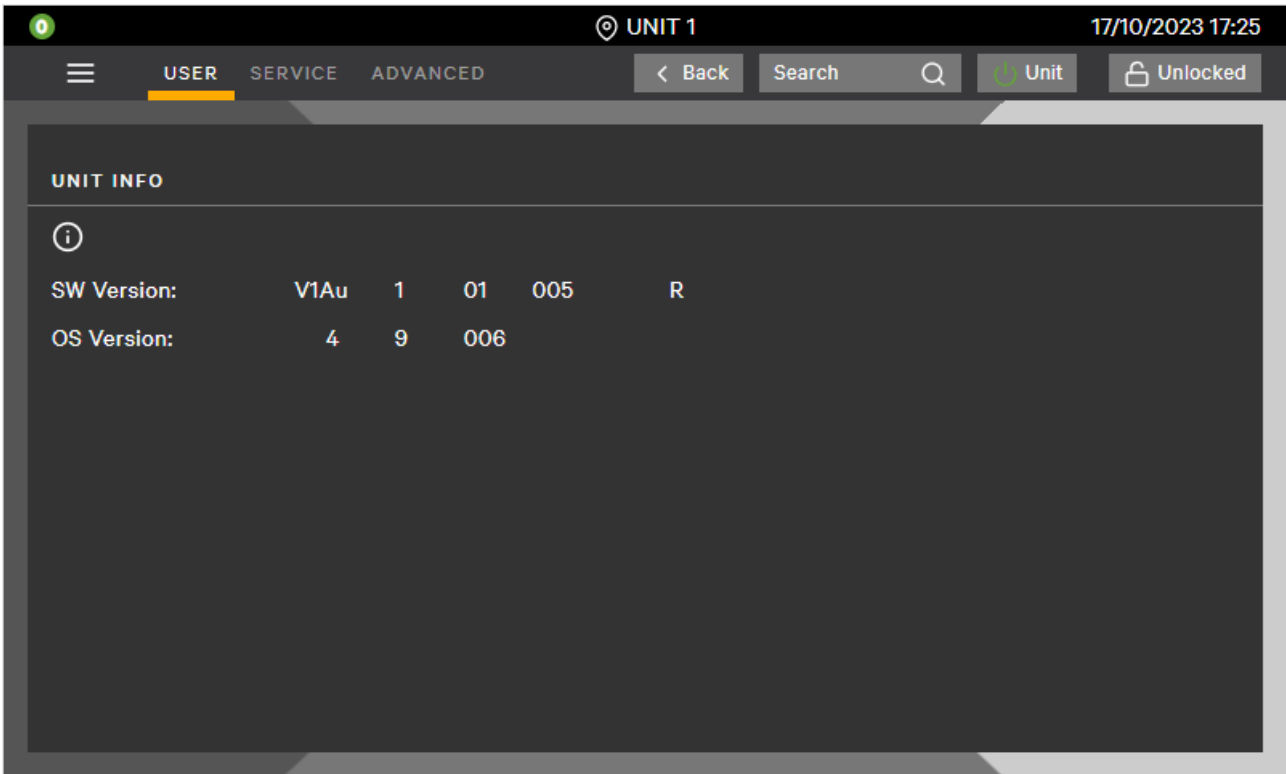

1.6.2 Fans

The Fans menu shows the status of each Modbus evaporating fan F01-F08 (Run, Alarm, Off, NoComm, N.A.). It also provides the airflow status (OK or NOK) and the fan speed request value.

If Static Pressure control is enabled, this menu will also display the pressure setpoint, dead band, and pressure values (local and system).

Additionally, if airflow rate measurement is enabled, the airflow rate will be shown.

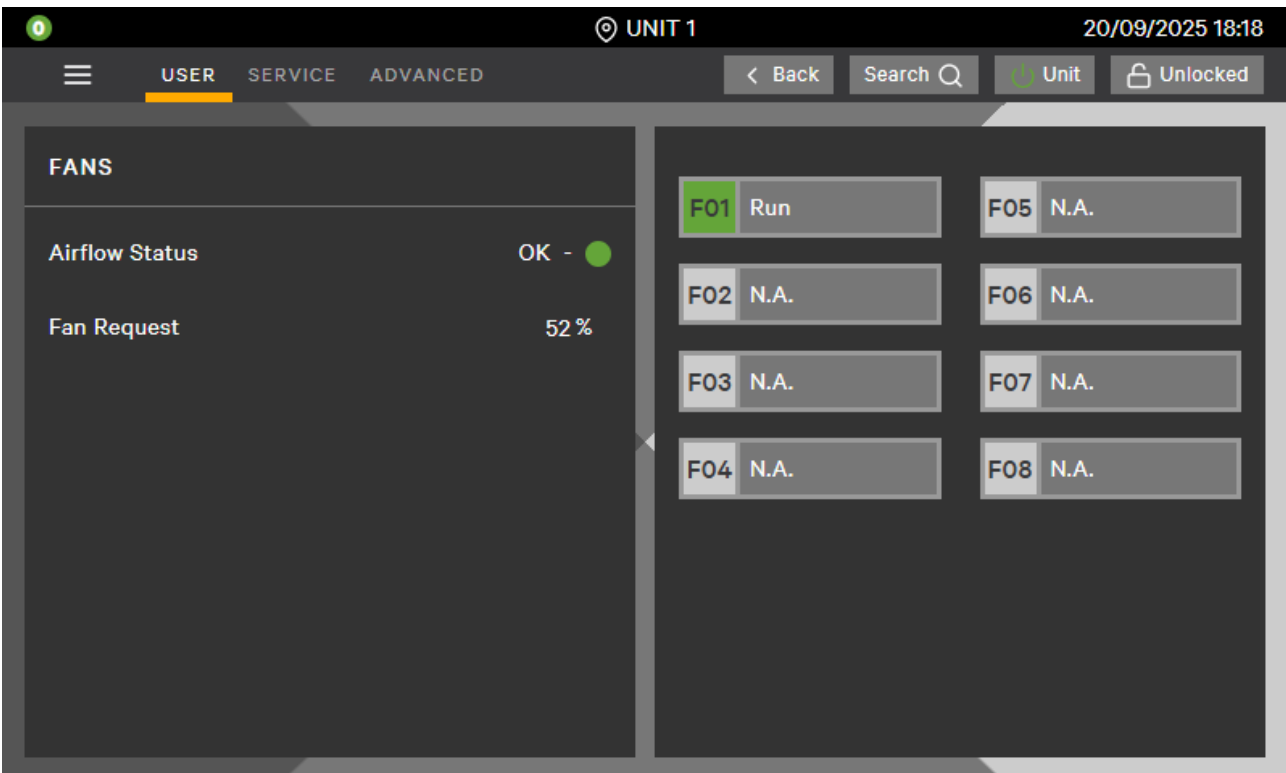

1.6.3 Compressors

Note: The Compressors menu is not available for the CW unit.

For each circuit, the menu provides information on:

The compressor C1-C2 status (Run, Alarm, Off, OnTime, OffTime, N.A.), the compressor thermal protection status (TH1-TH2), the Low pressure status (LP), the High pressure status (HP), the compressor capacity request in percentage, the minimum ON time countdown or the minimum OFF time countdown (Timer), the discharge pressure, the suction pressure, the current envelope working zone, the discharge temperature (optional), the suction temperature, the superheat and the EEV opening request value in percentage.

Regarding 'Timer':

- 'T-On' is a counter indicating the remaining compressor minimum ON time (starts when the compressor is ON). No indication (---) means the minimum ON time has elapsed.
- 'T-Off' is a counter indicating the remaining compressor minimum OFF time (starts when the compressor is OFF). No indication (---) means the minimum OFF time has elapsed.

The screenshot shows the 'UNIT 1' interface with the 'COMPRESSORS' menu selected. The 'CIRCUIT 1' section is active, displaying the following data:

CIRCUIT 1	
COMPRESSOR 1	
Request	35 %
Timer	T-On 143 s
Discharge Press	26.0 bar
Suction Press	9.5 bar
Envelope Zone	zone 1 - ●
Discharge Temp	75.0 °C
Suction Ref Temp	16.0 °C
Super Heat	7.1 K
EEV	25 %

On the right side of the interface, the status of various components is shown in a list:

- C1: OnTime
- C2: N.A.
- TH1: Closed
- TH2: Closed
- LP: Closed
- HP: Closed

1.6.4 Sensors

The Sensors menu showcases the temperature and humidity values from all connected (and enabled) sensors. In the presence of multiple sensors, these values reflect the minimum, maximum, or average value, depending on the set method.

If the AAT function is enabled, the menu will also display the 'Auxiliary Aggregated Temperature' (AAT) value and the 'Teamwork Aggregated Control Temperature' (TWACT) value.

SENSORS			
Return Temperature	22.0 °C	CW C2 Inlet Value	N.A.
Return Humidity	50.0 rh%	CW C2 Outlet Value	N.A.
Supply Temperature	18.0 °C	Optional Temp S1 Value	N.A.
Outdoor Temperature	N.A.	Optional Hum S1 Value	N.A.
Glycol Temperature	N.A.	Optional Temp S2 Value	N.A.
Remote Temperature	22.0 °C	Optional Hum S2 Value	N.A.
Remote Humidity	50.0 rh%	Optional Temp S3 Value	N.A.
Sup Safe Temperature	32.6 °C	Optional Hum S3 Value	N.A.
Air Economizer Outdoor Temp	N.A.	Cond. 1 Outdoor T Value	N.A.
Air Economizer Outdoor Hum	N.A.	Cond. 2 Outdoor T Value	N.A.
CW C1 Inlet Value	N.A.	Cond. Refrig. T1 Value	N.A.
CW C1 Outlet Value	N.A.	Cond. Refrig. T2 Value	N.A.
		Electrical Panel Temp Value	N.A.

The description of the optional sensors can be customized.

1.6.5 Condensers

Note: The Condensers menu is not available for the CW unit.

Air Cooled

This menu, for each circuit, provides the following information:

The status of each Modbus condensing fan CF1-CF4 (Run, Alarm, Off, NoComm, N.A.), condenser fan speed request in percentage, condenser mode (Pressure or Temperature), condenser discharge pressure (or temperature) value, and condenser pressure (or temperature) setpoint.

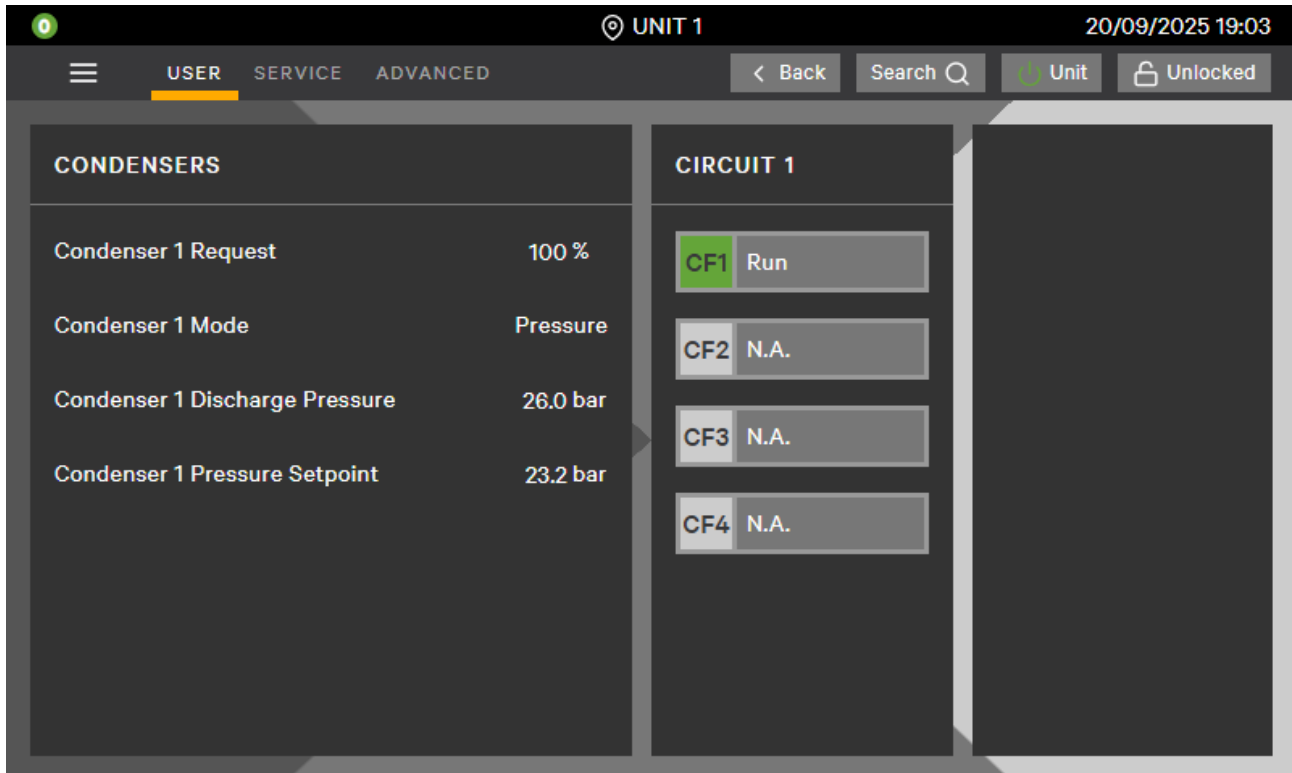

Water Cooled

This menu, for each circuit, provides the following information:

The condenser valve opening request in percentage, condenser discharge pressure value, and condenser pressure setpoint.

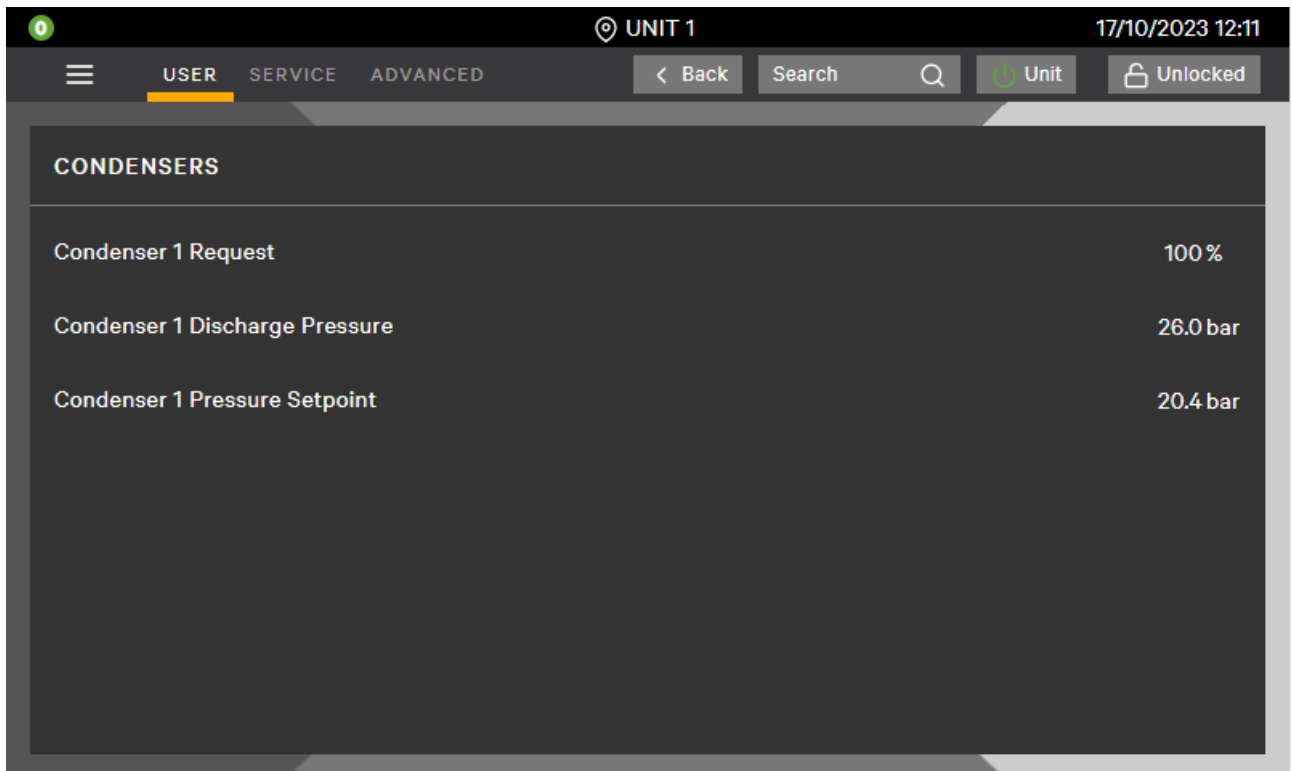

1.6.6 Inputs

'Inputs' includes configurable inputs CI1-CI8 settings and status (Open/Closed).

'Digital Inputs' includes the following:

- RE = Remote On/Off: Closed = Unit is ON (if other conditions are satisfied); Open = Unit is OFF (Remote OFF).
- CF = Clogged Filter (Digital): Closed = OK; Open = Clogged Filter warning.
- 3P = 3 Position Switch ON/OFF status: Closed = Unit is ON (if other conditions are satisfied); Open = Unit is OFF.
- MA = 3 Position Switch status: MAN = Fan and cooling are forced to 100%; AUTO = Unit is running in automatic mode; OFF = Unit is OFF.

Note: Up to 4 analog inputs (optional) are available for customers to translate an analog signal into physical values. These inputs are read from expansion board #2 and the resulting values have no control functionality or alarms. They are for visualization purposes only.

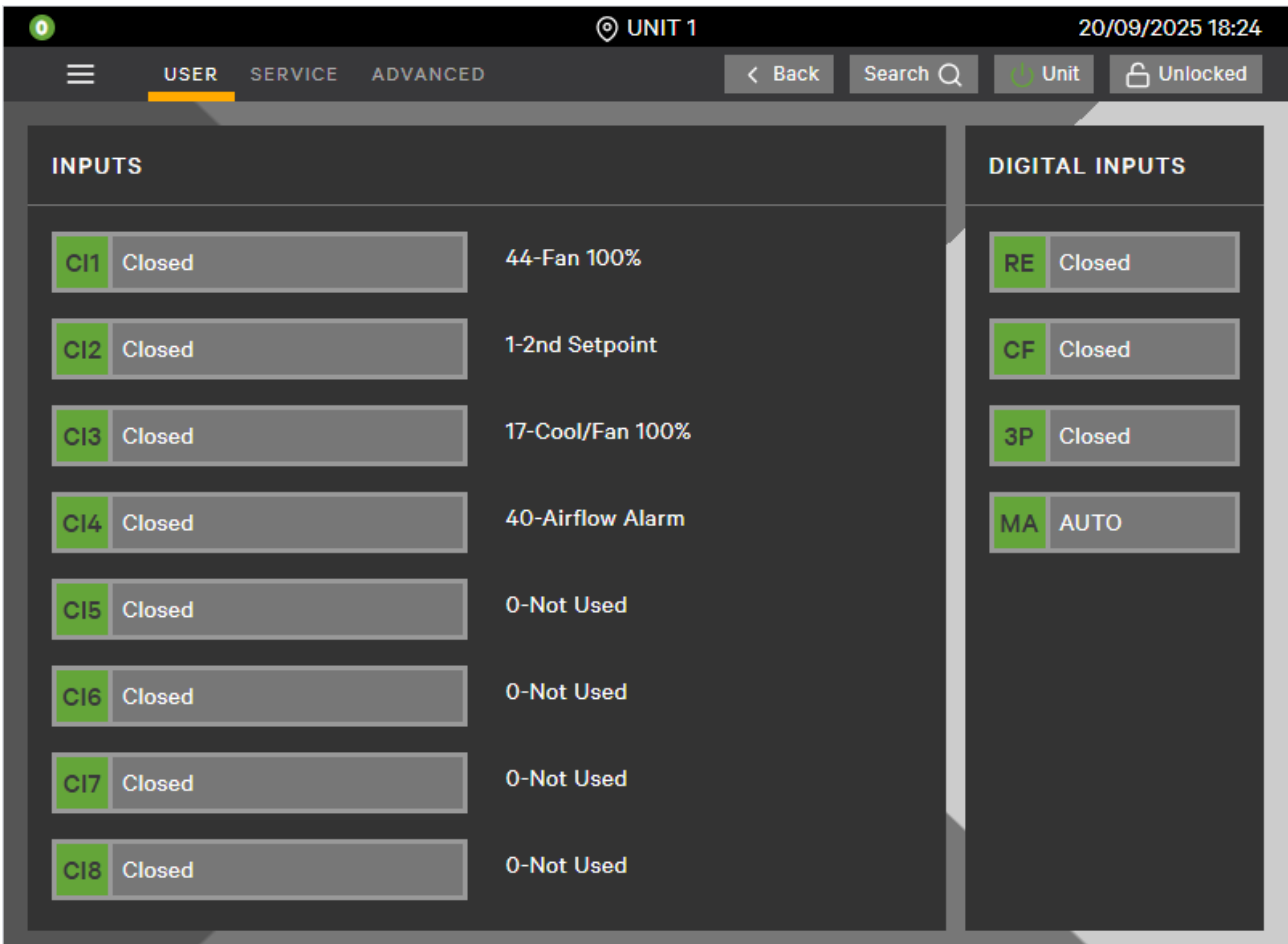

1.6.7 Outputs

For each analog output, the menu displays settings and percentage values.

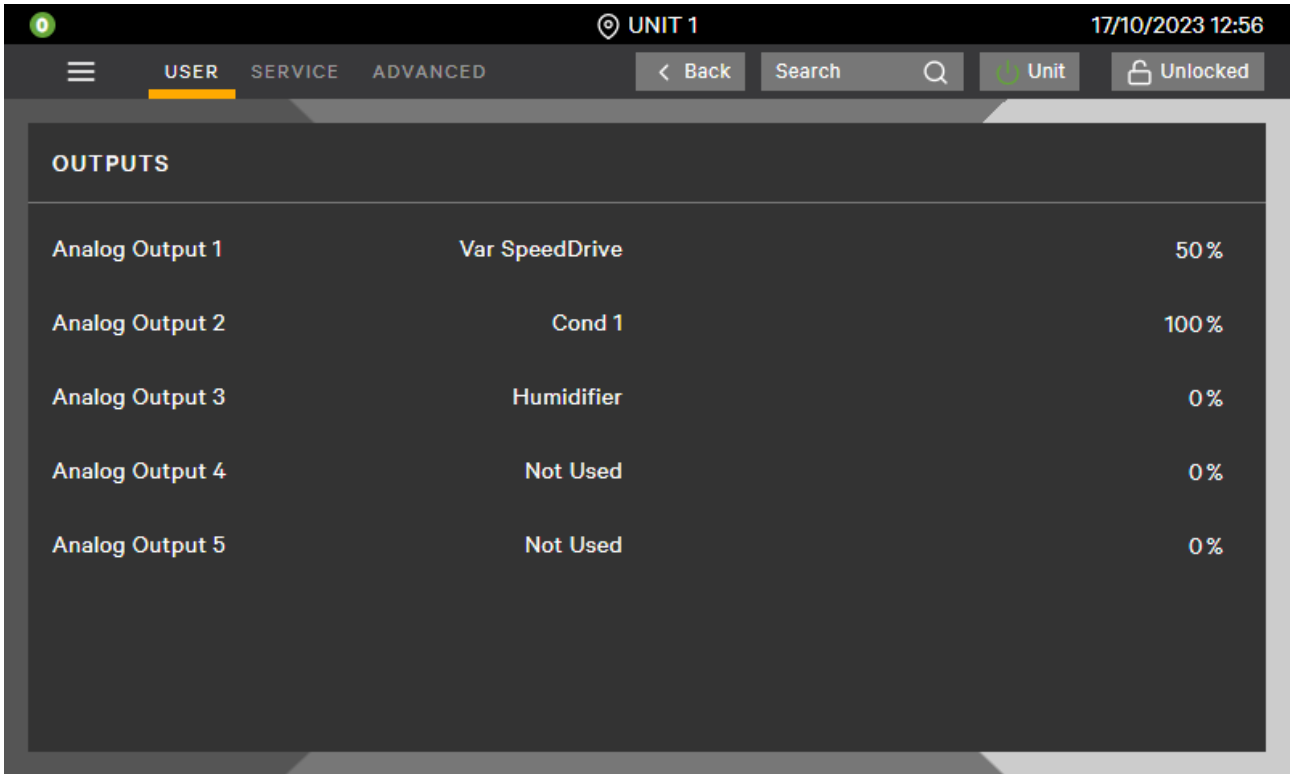

1.6.8 Heating

Note: The Heating menu is visible only if the heating option is enabled.

The menu includes the following:

- Heating First Step H1 Status (ON, OFF)
- Heating Second Step H2 Status (ON, OFF)
- High Temperature Counter

High Temperature Counter operates as follows: If the current Supply Temperature for Fan Safety is at or above the threshold (40°C), the electrical heaters will be stopped for 2 hours, and this counter will be increased by 1. A rolling 24-hour timer will be applied: if this counter reaches 3 within 24 hours, the electrical heater will be turned off. The electrical heaters can only restart if the counter is reset (Service/Options/El. Heater High Supply Temp menu).

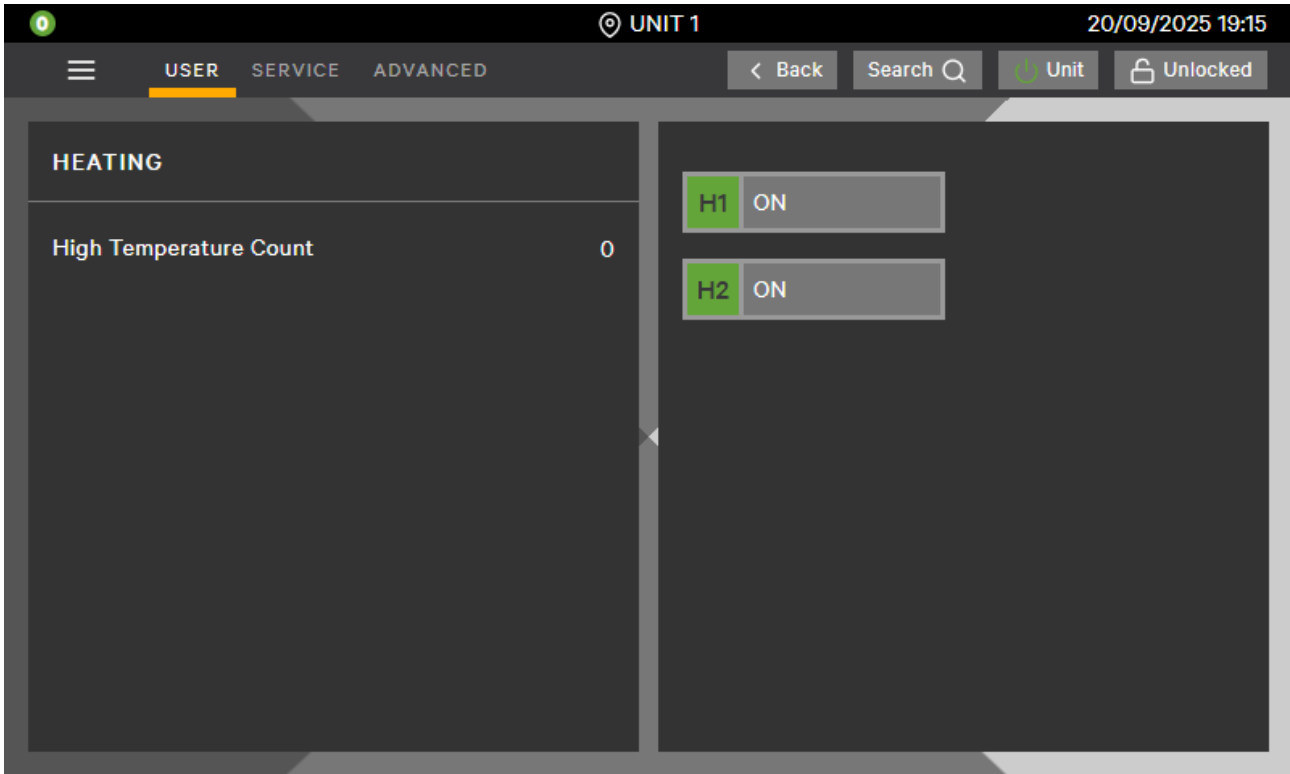

1.6.9 Hum/Dehum

Note: The Hum/Dehum menu is visible only if the option is enabled.

The menu includes the following:

- Humidification request in percentage and Humidifier status (HUM). Additional information will be shown in the case of electrode or infrared humidifier.
- Dehumidification request in percentage, status of dehumidification (DEH), Low Limit 1 status, and Low Limit 2 status.
- Low Limit 1 will disable one of the two compressors (or circuit in the case of tandem compressors) set for dehumidification. If only 1 compressor/circuit is set for dehumidification, or the dehumidification source is chilled water, this limit will not be considered.
- Low Limit 2 will disable all the cooling sources (compressors or chilled water) set for dehumidification.

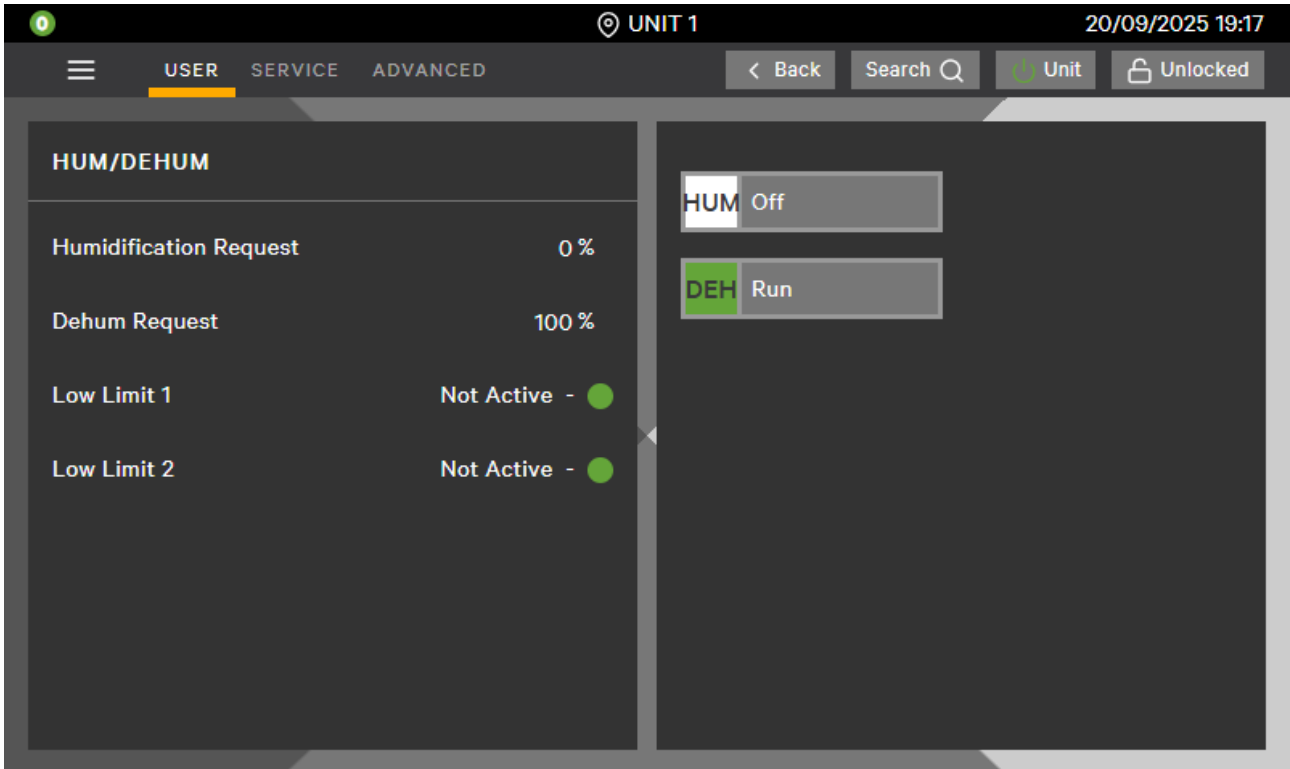

1.6.10 Chilled Water

Note: The Chilled Water menu is not accessible for DX units.

The menu provides the following information:

- Main Valve: Indicates the first CW valve (double circuit unit) to be activated in Cascade mode or the designated CW valve to run in Alternate mode.
- Operating Mode: Indicates the CW operating mode, with the following options:
 - Single = Utilizes only one CW circuit.
 - Parallel (double circuit) = Both valves are controlled simultaneously with the same logic.
 - Alternate (double circuit) = Allows only one hydraulic circuit to operate at a time. The 'Main Valve' parameter determines which valve takes priority.
 - Cascade (double circuit) = The main valve (defined by the 'Main Valve' parameter) covers the first 70% of the request. The second valve engages only if the request exceeds this threshold. If the request decreases below 50%, only the main valve continues to operate, and the second valve closes.
- CW Position Request: Indicates the opening request percentage for CW valve 1 and 2.
- CW Flow Value: Represents the volumetric water flow for each circuit, with values available in l/s or m3/h.
- CW Cooling Gross Capacity: Displays the cooling gross capacity (per circuit) calculated by the control based on volumetric water flow and inlet/outlet water temperatures.
- In the case of Supersaver enabled, the Supersaver signal will be shown.
- Additional values are displayed if Modbus valve feedback reading is enabled.

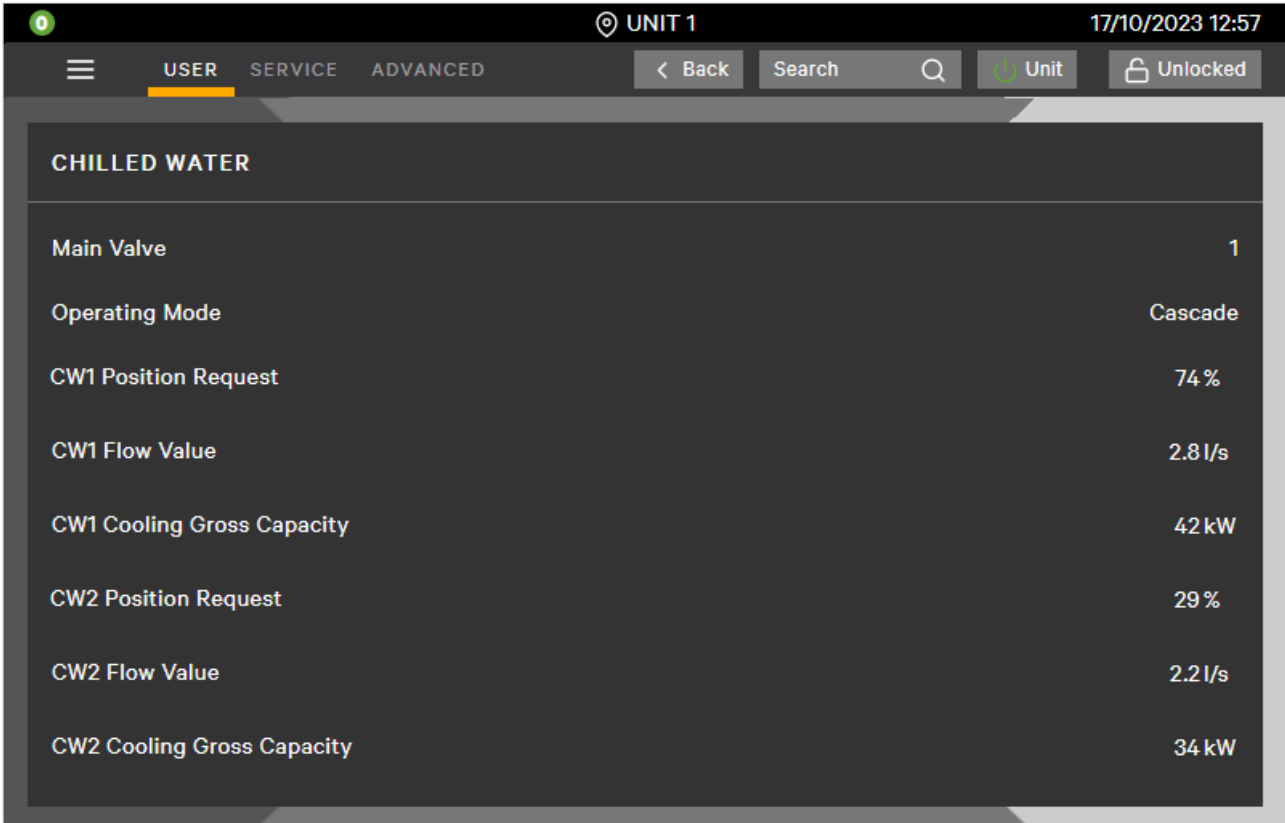

1.6.11 Air Economizer

Note: The Air Economizer menu will be hidden if the option is not selected.

The menu includes the following information:

- Air Eco Status: Provides the current status of the Air Economizer:
 - ON = The Air Economizer damper (outdoor) is open (>0%).
 - Emerg = The Air Economizer damper (outdoor) is open (>0%) due to Emergency Override. The emergency override will open the outdoor air damper and close the indoor air damper when the return temperature exceeds an adjustable high temperature.
 - OFF = The Air Economizer damper (outdoor) is closed (0%).
- Air Eco Position Request: Indicates the opening request of the Air Economizer damper (outdoor) in a range from 0 to 100%.
- Air Eco Outdoor Temperature: Displays the outdoor temperature.
- Air Eco Outdoor Humidity: Shows the outdoor humidity value.
- Actual Hum Ratio: Indicates the humidity ratio value (g/Kg).
- Hum Ratio Status: Reflects the status of the humidity ratio within the set minimum and maximum thresholds.
- Actual Wet Bulb T: Displays the wet bulb temperature value (°C).
- Wet Bulb Status: Represents the status of the wet bulb temperature considering the minimum threshold set.
- DT1: Indicates the status of the difference between the return temperature and outdoor temperature.
- DT3: Represents the status of the difference between the control temperature and control setpoint.
- DT4: Reflects the status of the humidity ratio and wet bulb temperature.
- The status (OK/NOK) of the DTs is overwritten during forcing conditions (i.e., Force FC) or if the Air Economizer is locked out.

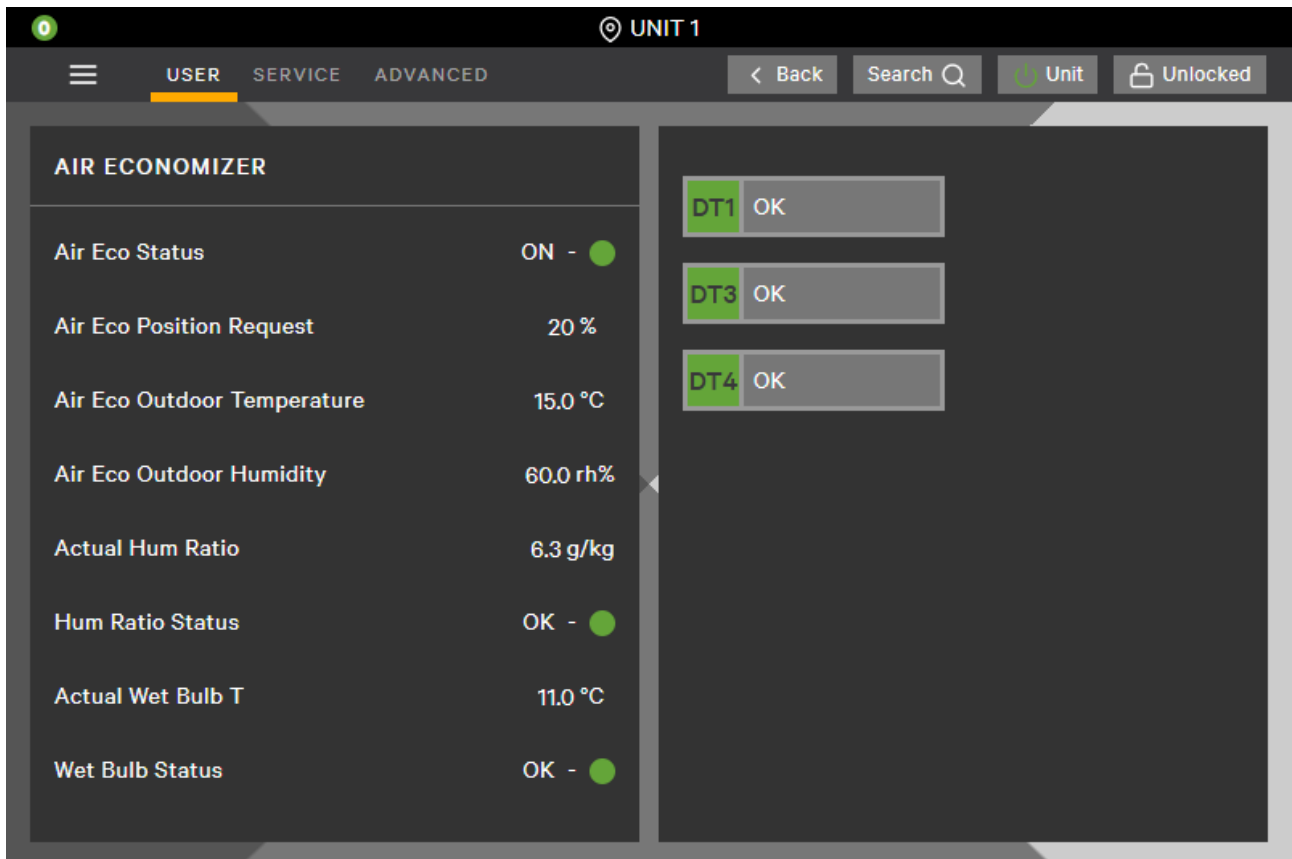

1.6.12 Energy Meter

Note: The Energy Meter menu will be hidden if the option is not selected.

The menu displays the following data obtained from the Energy Meter:

- E1 Device Status (OFF, OK, Unknown, CommErr or Disconn)
- Wiring (3Ph+N, 1Ph+N, 2Ph+N or 3Ph)
- Frequency [Hz]
- Instant Power [W]
- Total Energy [kWh]
- Voltage L1-N [V]
- Voltage L1-L2 [V]
- Voltage L2-N [V]
- Voltage L2-L3 [V]
- Voltage L3-N [V]
- Voltage L3-L1 [V]
- Current L1 [A]
- Current L2 [A]
- Current L3 [A]

The 'Energy Meter Offline' event will occur if the Energy Meter is enabled but not connected.

The screenshot shows a user interface for 'UNIT 1' on '20/09/2025 18:41'. The interface has a top navigation bar with 'USER', 'SERVICE', and 'ADVANCED' tabs. Below this is a search bar and buttons for 'Back', 'Unit', and 'Unlocked'. The main content area is titled 'ENERGY METER' and contains several data sections:

- Wiring:** 3Ph+N, **Power:** 1202 W
- Frequency:** 50.0 Hz, **Energy:** 542 kWh
- VOLTAGE:**

#	L1	L2	L3
△	400.0 V	395.0 V	407.0 V
⋈	230.0 V	231.0 V	232.0 V
- CURRENT:**

L1	L2	L3
6.0 A	5.1 A	6.2 A

On the right side of the interface, there is a status indicator for 'E1' which is 'OK'.

1.6.13 T/H Graphs

The first graph represents the trend of:

- Return Temperature (orange)
- Remote Temperature (light blue)
- Supply Temperature (dark blue)

The second graph represents the trend of:

- Return Humidity (orange)
- Remote Humidity (light blue)

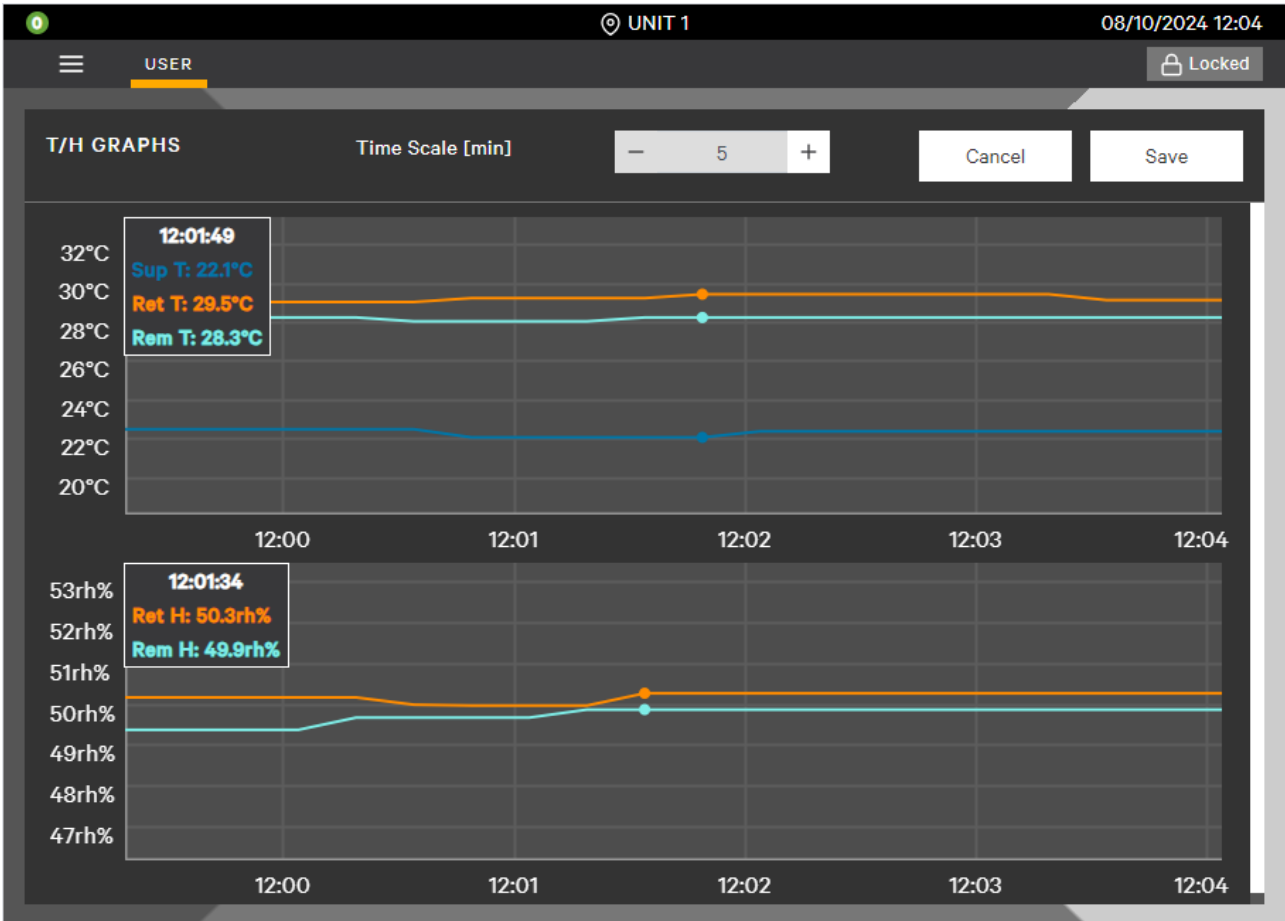

Touch the graph to display the icon in the top-left corner, which will show the temperature or humidity values along a timeline. The Time Scale determines the logging duration in minutes (maximum 1440 minutes = 24 hours).

1.6.14 Service Contacts

The Service Contacts menu includes a list of local service phone numbers.

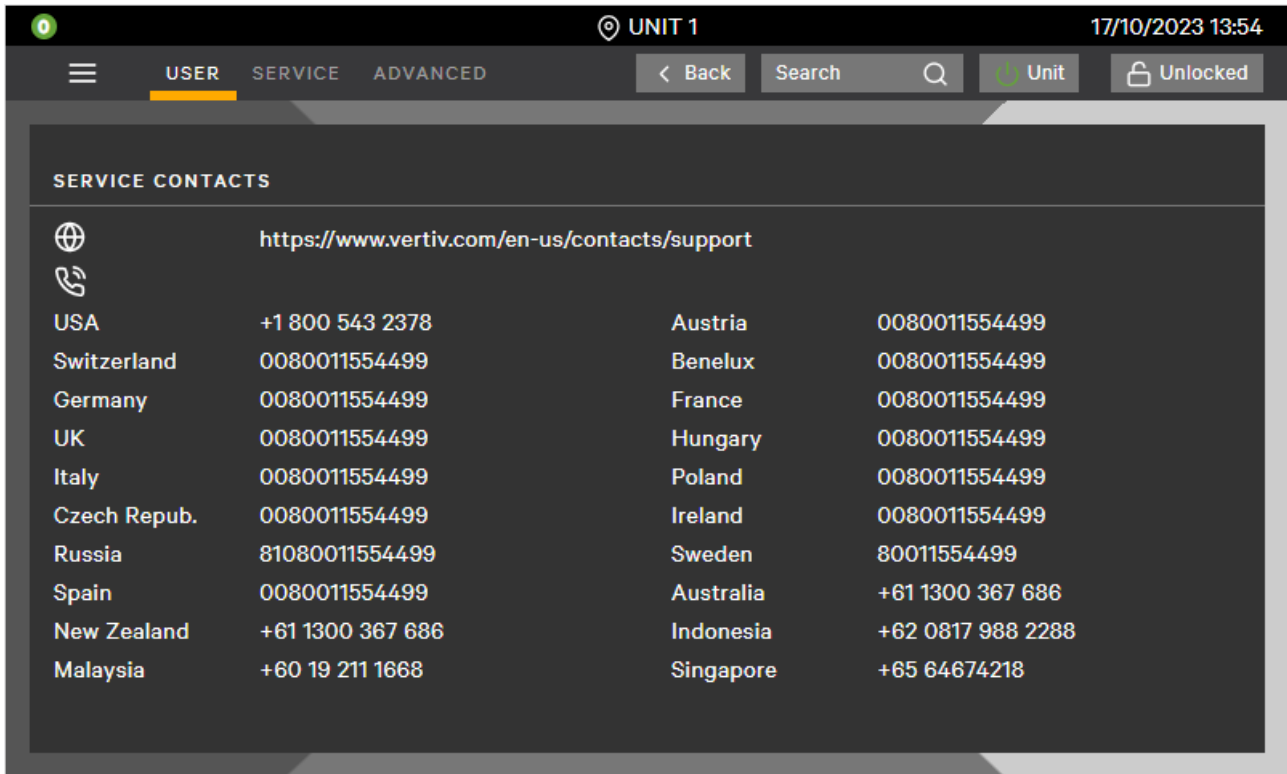

1.6.15 EconoPhase

Note: The EconoPhase menu will be hidden if the option is not selected.

The menu includes the following information:

- Return Temperature
- Supply Temperature
- Remote Temperature
- Outdoor Temperature (Max between Circuit 1 and 2)
- Operating Mode:
 - Compressor = The unit can run in pure DX mode only
 - Mixed = Circuit 1 is running in Pump mode; Circuit 2 is running in DX mode
 - Pump = The unit can run in pure Pump mode
- Pump 1 and 2 Speed request
- Pump 1 and 2 Delta Pressure
- Suction Temperature Circuit 1 and 2
- Outlet Temperature Circuit 1 and 2
- Condenser 1 and 2 Fan speed
- P1 represents the status of the Pump 1 (ON or OFF)
- P2 represents the status of the Pump 2 (ON or OFF)

The screenshot displays the 'ECONOPHASE' control interface for 'UNIT 3'. At the top, there is a navigation bar with 'USER', 'SERVICE', and 'ADVANCED' tabs. The 'USER' tab is selected. To the right of the navigation bar are buttons for '< Back', 'Search', 'Unit', and 'Unlocked'. The main display area is divided into several sections:

- ECONOPHASE Summary:**
 - Return Temperature: 22.0 °C
 - Remote Temperature: 22.0 °C
 - Supply Temperature: 18.0 °C
 - Outdoor Temperature: 1.5 °C
 - Operating Mode: Pump
- PUMP 1 Details:**
 - Request: 60 %
 - Delta Pressure: 1.6 bar
 - Suction Temp: 16.0 °C
 - Outlet Temp: 1.4 °C
 - Condenser: 22 %
- PUMP 2 Details:**
 - Request: 0 %
 - Delta Pressure: 0.0 bar
 - Suction Temp: 16.0 °C
 - Outlet Temp: 0.0 °C
 - Condenser: 0 %
- Pump Status:**
 - P1: ON
 - P2: OFF

1.6.16 Daily High/Low T/RH/DP

This menu displays the daily high and low values, along with the respective times of the day, for the control temperature, return humidity, and dew point.

The screenshot shows a control application interface for 'UNIT 1' on '17/10/2023 12:57'. The interface includes a navigation bar with 'USER', 'SERVICE', and 'ADVANCED' tabs, and a top bar with 'Back', 'Search', 'Unit', and 'Unlocked' buttons. The main content area displays a table titled 'DAILY HIGH/LOW T/RH/DP' with the following data:

Parameter	Time	Value
High Control Temperature	18 : 30 : 12	23.6 °C
Low Control Temperature	18 : 30 : 31	21.4 °C
High Return Humidity	18 : 30 : 26	50.4 rh%
Low Return Humidity	18 : 30 : 42	48.7 rh%
High Dew Point	18 : 30 : 21	12.7 °C
Low Dew Point	18 : 30 : 44	10.1 °C

1.6.17 Fluid Economizer

Note: The Fluid Economizer menu will be hidden if the option is not selected.

The menu includes the following information:

- FC Status: Provides information about the Fluid Economizer status:
 - START = DT1 (if enabled) is OK.
 - ON = The Fluid Economizer (FC valve) is operating.
 - OFF = The Fluid Economizer (FC valve) is closed.
- FC Valve Position Request: Indicates the opening request for the FC valve in a range from 0 to 100%.
- Lockout FC: Indicates whether the Fluid Economizer is currently locked out.
- Lockout Comp: Indicates whether the compressor(s) is currently locked out.
- DT1 Status: Represents the status of the temperature difference between the return temperature and outdoor temperature.
- DT2 Status: Represents the status of the temperature difference between the control temperature and glycol temperature.
- DT3 Status: Represents the status of the temperature difference between the control temperature and control setpoint.
- The status (OK/NOK) of the DTs is overridden during forcing conditions (e.g., Force FC) or if the Fluid Economizer is locked out.

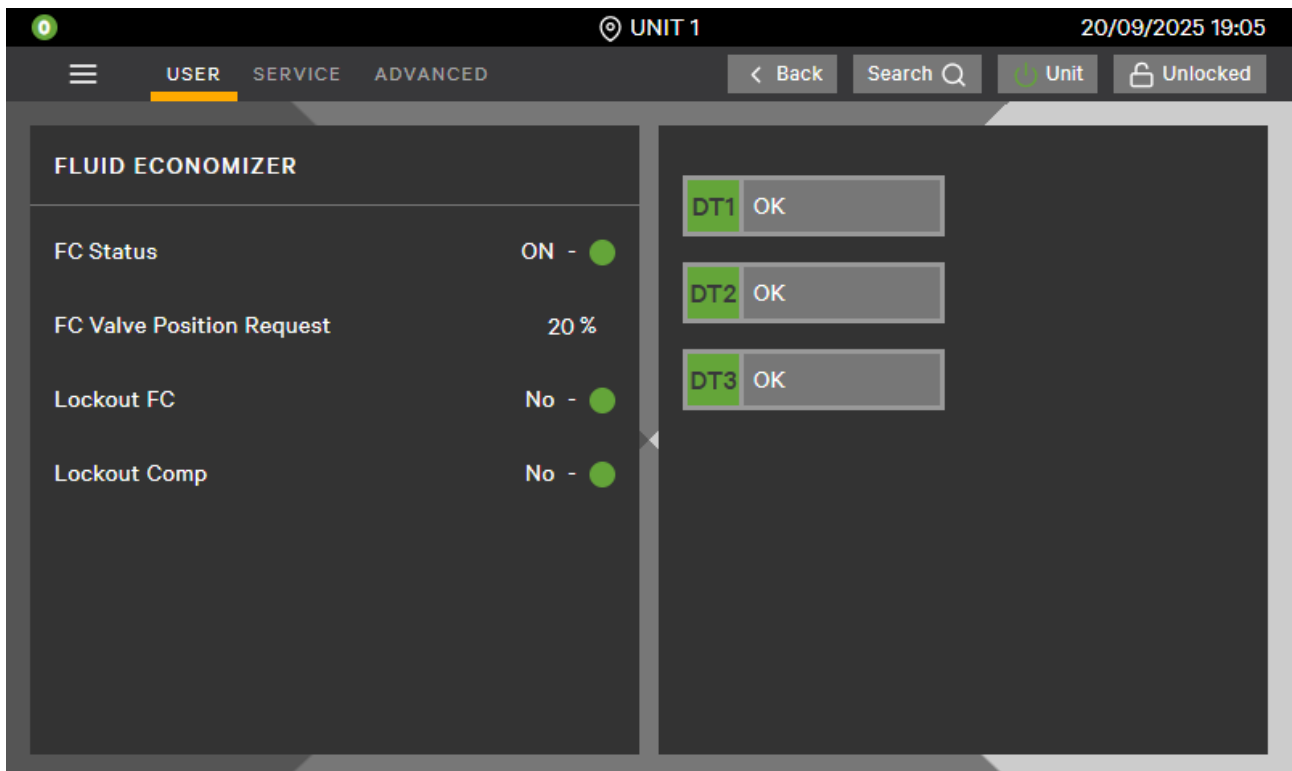

1.6.18 ATS

The optional Lovato ATS (Automatic Transfer Switch) control seamlessly transitions to a secondary power source in the event of a primary power loss and automatically returns to the primary source when it becomes available.

The Lovato ATS serves as the primary unit for switching between power sources, offering the following features:

- Determination of power availability in both primary and secondary sources.
- Selection of the primary and secondary power sources.
- Automatic switching from the primary to the secondary source in the event of a primary power loss.
- Automatic switching from the secondary to the primary source when the primary power is restored.
- Visible indication of available power sources.
- Visible indication of the active power source.

Note: The ATS menu will be hidden if the option is not selected.

The menu lists the following data read from the ATS:

- Communication Status [COM] (Offline, Online)
- Line 1 State [L1] (Not OK, OK)
- Line 2 State [L2] (Not OK, OK)
- Control Mode (Unknown, Off, Manual, Auto, Test)
- Line Active (Line 1, Line 2)
- Global Alarm (Not Active, Active)
- Error (Not Active, Active)
- Line 1 Breaker (Closed, Alarm, Unknown, Command Status, Close Command, Open Command)
- Line 1 Frequency [Hz]
- Line 1 Voltage L1-L2 [V]
- Line 1 Voltage L2-L3 [V]
- Line 1 Voltage L3-L1 [V]
- Line 2 Breaker (Closed, Alarm, Unknown, Command Status, Close Command, Open Command)
- Line 2 Frequency [Hz]
- Line 2 Voltage L1-L2 [V]
- Line 2 Voltage L2-L3 [V]
- Line 2 Voltage L3-L1 [V]

The 'ATS Error' event will occur if the ATS is enabled but not connected (auto reset).

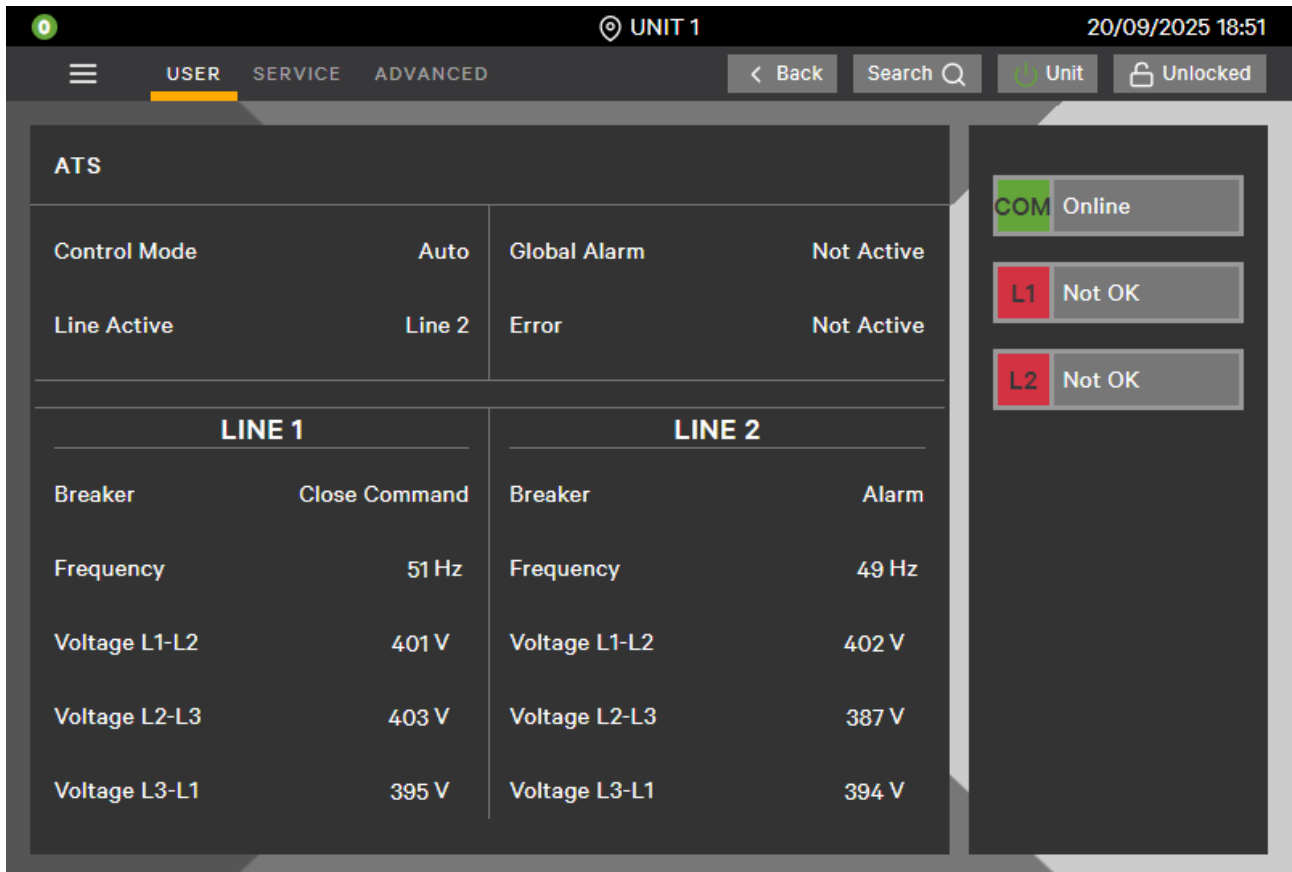

2 Small Display





The Small Display is a semi-graphic terminal with a resolution of 132x64 pixels. It features six buttons for screen navigation and includes an audible signal generated by a buzzer. The connection to the controller is established via an RJ12 telephone cable.





2.1 keyboard Icons and Functions

Icon	Key Name	Function
	Alarm Key	Provides access to the Events Report menu. Silences the audible signal and resets the active event. [The LED blinks red when an event is active; pressing the Alarm key stops the red LED from blinking].
	On/Off Key	Provides access to the Unit ON/OFF menu. [The LED is yellow when the unit is ON].
	Escape Key	Returns to the previous menu. Cancels the current entry row.
	Increase Key (Up Arrow)	Moves upward through the pages, moves to the left through the menu icons, or increases the value of the selected parameter.
	Enter Key	Confirms all selections, icons, and values.
	Decrease Key (Down Arrow)	Moves downward through the pages, moves to the right through the menu icons, or decreases the value of the selected parameter.

2.1.1 Contrast Adjustment

Adjust the contrast by pressing the Escape () + Alarm () + On/Off () + Increase () / Decrease () buttons.

2.1.2 Audible and Visible Indicators

When an Alarm/Warning condition occurs, it activates a red LED indicator () and an audible signal (buzzer). Once the fault condition is resolved, both audible and visible indicators can be reset through the Active Events menu or by pressing and holding the Alarm Key () for 3 seconds.

To reset a single event, select it by pressing the Enter Key () and then proceed with the reset.

2.2 Password Protection

A password is required to access any configuration menu. The table below outlines the three levels of access (User, Service, and Advanced) along with the main options available for each.

Level / Username	Accessibility
user	The User level (low level) permits the modification of parameters such as the temperature setpoint, which are typically utilized to define the operating point of the unit.
service	The Service level (medium level) grants access to changing parameters that define the operating mode of the unit.
advanced	The Advanced level (high level) provides the capability to identify the unit based on the type of devices mounted on board.

Press the Enter Key (↵) to open the Password window. Enter the password using the Increase (⬆) or Decrease (⬇) key, and confirm by pressing the Enter key (↵).



After entering one of the three passwords, the user gains access to the corresponding menu. Higher password levels also enable navigation/operation on lower menu levels. Sessions will automatically terminate after 5 minutes of no key activity. If an incorrect password is entered, the system displays a 'wrong password' message.

2.3 Unit ON/OFF

The unit can be switched ON/OFF from four different sources:

- **Remote ON/Off:** Unit ON or OFF via a remote contact (digital input). The status indication in the case of an OFF command is 'Remote Off', accompanied by the message 'UNIT OFF BY REMOTE INPUT'.
- **3 Position Switch ON/Off (Optional):** Unit ON or OFF via a 3-Position Switch (digital input). The status indication in the case of an OFF command is '3Pos Switch Off', and the message 'UNIT OFF BY 3 POS SWITCH' will be displayed.
- **Display ON/OFF button:** Unit ON or OFF via the Display (Touch Display, Small Display, or web browser). The status indication in the case of an OFF command is 'Display Off', and the message 'DISPLAY OFF' will be shown.

Press the On/Off Key (Ⓞ) to access the Unit ON/OFF menu. Turn the unit ON or OFF by pressing the Increase (⬆) or Decrease (⬇) Key for 3 seconds.



- **Monitoring ON/Off:** Unit ON or OFF controlled by BMS (Building Management System). The status indication in the case of an OFF command is 'Monitoring Off', and the message 'UNIT OFF BY MONITORING' will be displayed.

All four OFF possibilities are connected in series. The unit will start only if ALL are activated, and it will stop if any one of them is deactivated.

The unit will be switched OFF by a critical alarm if any of the following events are active:

- Stop Due to High Temp (Unit Out of Working Range Routine) if 'Stop Due to High Temp' parameter is set to 'Yes'. This parameter is available for CW unit only.
- Water Alarm (LWD) if 'LWD' parameter is set to 'Yes'.
- Smoke Alarm if 'Smoke Alarm' parameter is set to 'Yes'.
- Loss of Air Flow if 'Loss of Airflow' parameter is set to 'Yes'.
- High Supply Temperature if 'High Supply Temperature' parameter is set to 'Yes'.
- Loss of Flow (Configurable Input set as 'Flow AL SD').
- Condensing Pump Alarm (Configurable Input set as 'Cond Pump SD').
- Fire Alarm.
- Configurable Alarm (Configurable Input set as 'Alarm').
- Wrong Damper Position (Damper Control).
- Expansion Board 1 Offline in configuration DX + Air Economizer.

The status 'Alarm OFF' and the message 'UNIT OFF BY ALARM' will be shown.

Unit Auto Restart

If disabled, the unit will NOT restart after a power cycle.

If enabled (default setting), the unit will resume the same status it had before the power cycle: ON if it was ON before, OFF if it was OFF.

2.3.1 System On/Off

The System On/Off command is disabled by default. If enabled the entire system can be switched on or off from two sources:

- **Display On/Off button:** The system is switched on or off via the display. To access the System On/Off menu, press the On/Off Key (Ⓞ) twice. Then, turn the system on or off by pressing the Increase (⬆) or Decrease (⬇) Key for 3 seconds.

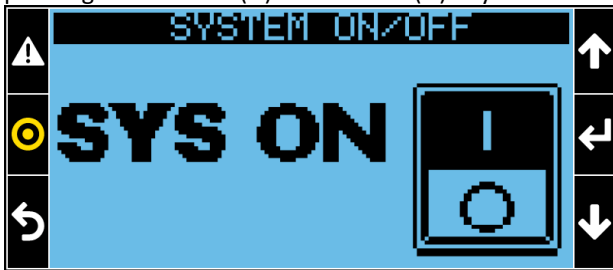

- **Monitoring ON/Off:** The system is switched on or off by BMS (Building Management System).

In Teamwork Mode 0 (No Teamwork) and without standby units, the System On/Off command will not have any effect on the units.

Note: When the system is turned on, the units will maintain the same status as before the system off command.

2.4 Main Screen

The main screen on the Small Display shows:

- Status of the unit.
- Current date and time.
- Current temperature and humidity setpoints (Set).
- Return temperature and humidity values (Ret).
- Supply temperature value (Sup).
- Remote temperature and humidity values (Rem) if remote sensors installed.

The highlighted field (in this case, 'Ret') indicates the temperature sensor utilized by the application for managing the cooling source.

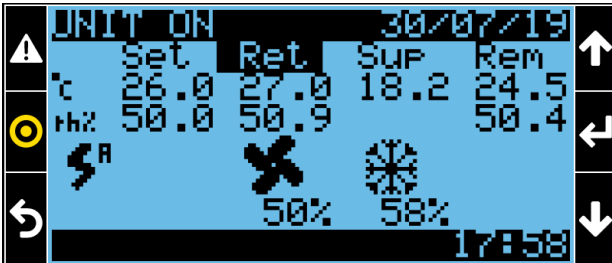

Icons with percentages appear on the main screen when the relevant working mode is running:

Icon	Device
	Evaporator Fan ON
	DX: Compressor ON CW: CW Valve Open (>0%)
	Air Economizer ON or Fluid Economizer ON or EconoPhase ON
	DX (DX+FC): Compressor ON + Air Economizer ON or Fluid Economizer ON or EconoPhase ON CW (CW+FC): CW Valve Open (>0%) + Air Economizer ON
	Electrical Heating ON
	Dehumidification Active
	Humidifier ON
	ATS: Power Supply A is feeding the unit
	ATS: Power Supply B is feeding the unit
	Ultracapacitor is feeding the main control board (with time indication)

At the bottom of the window, the System Off status, specific working conditions, forcing, or limitations are displayed.

2.5 User Menu

Main User Menu icons view

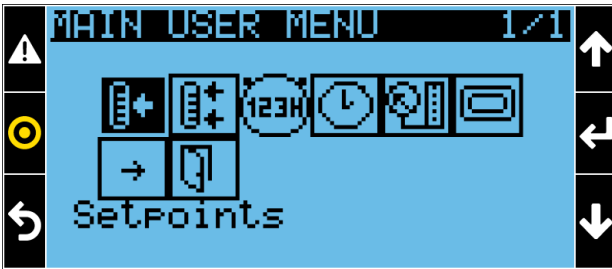

This icon  allows access to the next menu (Service) only if the user has the correct permissions set.

2.5.1 Setpoints



Setpoints menu page 1 of 5

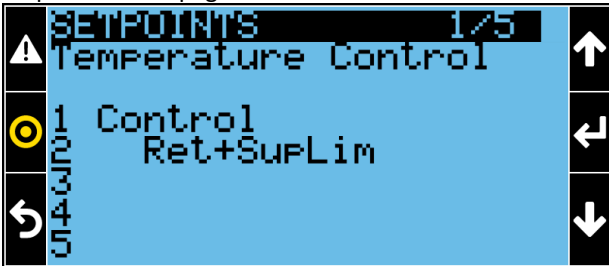

Line #1: Text only 'Control'.

Line #2: Set the desired temperature control method. The available options include 'Return', 'Supply', 'Return + Supply Limit', and 'Remote'.

Setpoint menu page 2 of 5

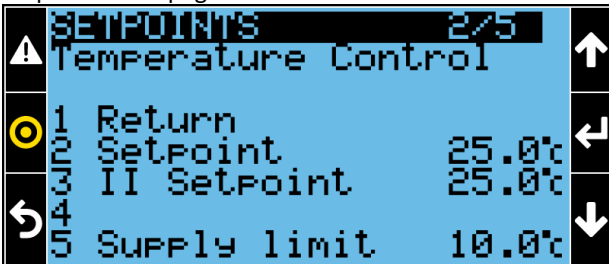

Line #1: Indicates (read-only) the temperature control method set on the previous page.

Line #2: This represents the desired air temperature. The control compares the measured value with the temperature setpoint to determine whether to initiate cooling or heating.

Line #3: This represents the second setpoint. It will be used in place of the standard temperature setpoint if one of the configurable inputs is set to '2nd Setpoint', and the corresponding input is open (active). The message 'Second Set Point Active' will be displayed.

Line #5: This indicates the low limit for the supply temperature. The control aims to maintain the supply temperature higher than the set value. This row is visible only in the 'Return + Supply Limit' configuration.

Setpoints menu page 3 of 5

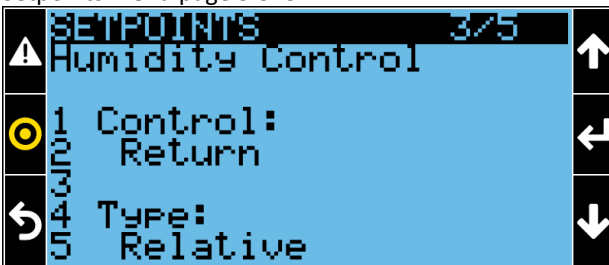

Line #1: Text only 'Control:'

Line #2: Set the desired humidity control method. The available options are 'Return' and 'Remote'.

Line #4: Text only 'Type:'

Line #5: Set the humidity control type. The available options include 'Relative', 'Relative Compensated', 'Absolute', and 'Dew Point'.

Setpoints menu page 4 of 5

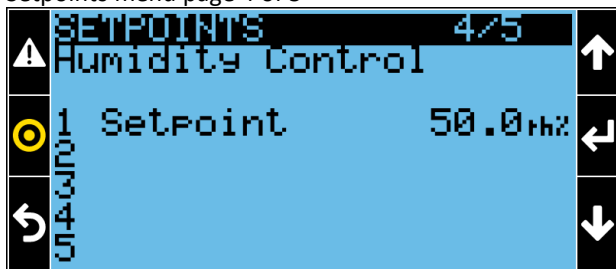

Line #1: This represents the desired air humidity level. The control compares the measured value with the humidity setpoint to determine whether to initiate humidification or dehumidification.

Setpoints menu page 5 of 5

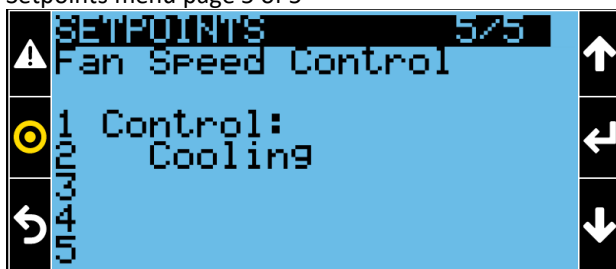

Line #1: Text only 'Control:'

Line #2: Set the desired fan control method. The available options include 'Return', 'Supply', 'Remote', 'Delta Ret-Sup', 'Static Press', 'Ret CW Priority', 'Fixed', 'Cooling', and 'Delta Ret-Rem'. In all cases, except 'Cooling', an additional menu for setting the desired setpoint or speed will be displayed.

- Return: The fan speed is modulated from the minimum to the maximum speed set following the return temperature deviation.
- Supply: The fan speed is modulated from the minimum to the maximum speed set following the supply temperature deviation.
- Remote: The fan speed is modulated from the minimum to the maximum speed set following the remote temperature deviation.
- Delta Ret-Sup: The speed of the evaporating fans is modulated to maintain a constant delta T between return temperature and supply temperature. When the delta T falls within the dead band, the fan speed remains unchanged. When the delta T goes beyond the dead band, the control adjusts the fan speed (increasing or decreasing) to bring the delta T back within the dead band.
 - If the delta between return temperature and supply temperature is lower than the delta setpoint, the fan speed will decrease.
 - If the delta between return temperature and supply temperature is higher than the delta setpoint, the fan speed will increase.

This functionality is not available in Teamwork Mode 1 and 3.

The current fan speed request persists after a unit restart. When the unit starts and is beyond the fan start speed duration, the control will apply the stored speed.

- Static Press: The speed of the evaporating fans is modulated to maintain constant the static pressure. When the pressure falls within the dead band, the fan speed remains unchanged. When the pressure goes beyond the dead band, the control adjusts the fan speed (increasing or decreasing) to bring the pressure back within the dead band.
 - If the pressure is lower than the Setpoint band, the fan speed will increase.
 - If the pressure is higher than the Setpoint band, the fan speed will decrease.

In Teamwork Mode 1 and 3 all units will use the system pressure value calculated by the primary unit. The 'DP is based on' parameter determines whether the control uses the average value (default setting) or the minimum value of the system. The 'Teamwork is based on' parameter setting is disregarded by the control for this function.

The current fan speed request persists after a unit restart. When the unit starts and is beyond the fan start speed duration (reduced to 5 seconds), the control will apply the stored speed.

- Ret CW Priority: The CW valve modulates between 0% and 50% of the call for cooling based on return temperature. The Fan speed modulates between 50% and 100% of the call for cooling based on return temperature. This means the fan starts modulating only when the CW valve is fully open.
- Fixed: During normal operation, the fan operates at the set fixed speed. The fan speed can be overridden due to predefined working conditions (if higher) or for unit safety reasons.
- Cooling: The Fan speed will follow the same strategy (PI) used for the temperature control (coupled mode).

- Delta Ret-Rem: The speed of the evaporating fans is modulated to maintain a constant delta T between the return temperature and remote temperature. When the delta T falls within the dead band, the fan speed remains unchanged. When the delta T goes beyond the dead band, the control adjusts the fan speed (increasing or decreasing) to bring the delta T back within the dead band.
 - If the delta between Return and Remote temperatures is lower than the delta setpoint, the fan speed will decrease.
 - If the delta between Return and Remote temperatures is higher than the delta setpoint, the fan speed will increase.

In Teamwork Mode: The 'DT is based on' parameter determines whether the Delta Temperature value used by the control is the average value (default setting) or the maximum value of all DTs in the system. The setting of the 'Teamwork is based on' parameter is disregarded by the control for this function.

The current fan speed request persists after a unit restart. When the unit starts and is beyond the fan start speed duration, the control will apply the stored speed.

2.5.2 High/Low Limits



High/Low Limits menu page 1 of 5

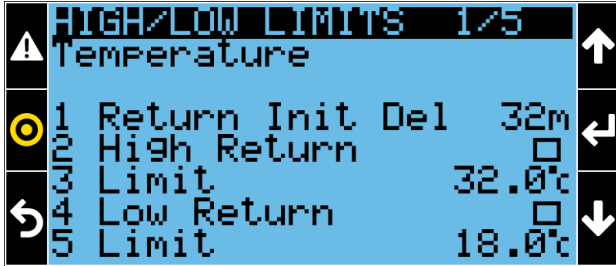

Line #1: The (auto-reset) events are ignored at unit ON for the duration set by this parameter.

Line #2: Enables the 'High Return Temperature' event.

Line #3: Defines the threshold for High Return Temperature. If the actual return temperature exceeds the set threshold for 30 seconds, the 'High Return Temperature' event will be triggered.

Line #4: Enables the 'Low Return Temperature' event.

Line #5: Defines the threshold for Low Return Temperature. If the actual return temperature falls below the set threshold for 30 seconds, the 'Low Return Temperature' event will be triggered.

High/Low Limits menu page 2 of 5

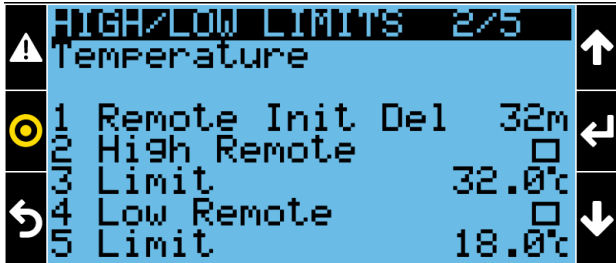

Line #1: The (auto-reset) events are ignored at unit ON for the duration set by this parameter.

Line #2: Enables the 'High Remote Temperature' event.

Line #3: Defines the threshold for High Remote Temperature. If the actual remote temperature exceeds the set threshold for 30 seconds, the 'High Remote Temperature' event will be triggered.

Line #4: Enables the 'Low Remote Temperature' event.

Line #5: Defines the threshold for Low Remote Temperature. If the actual remote temperature falls below the set threshold for 30 seconds, the 'Low Remote Temperature' event will be triggered.

High/Low Limits menu page 3 of 5

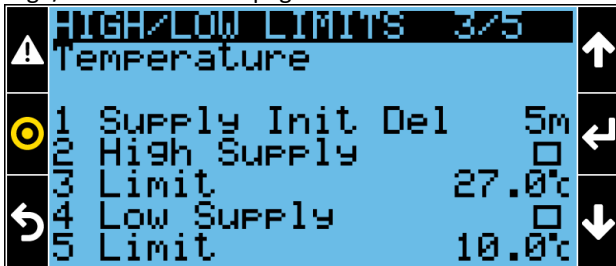

Line #1: The (auto-reset) events are ignored at unit ON for the duration set by this parameter.

Line #2: Enables the 'High Supply Temperature' event.

Line #3: Defines the threshold for High Supply Temperature. If the actual supply temperature exceeds the set threshold for 30 seconds, the 'High Supply Temperature' event will be triggered.

Line #4: Enables the 'Low Supply Temperature' event.

Line #5: Defines the threshold for Low Supply Temperature. If the actual supply temperature falls below the set threshold for 30 seconds, the 'Low Supply Temperature' event will be triggered.

High/Low Limits menu page 4 of 5

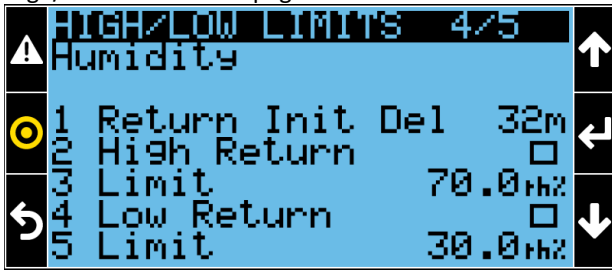

Line #1: The (auto-reset) events are ignored at unit ON for the duration set by this parameter.

Line #2: Enables the 'High Return Humidity' event.

Line #3: Defines the threshold for High Return Humidity. If the actual return humidity exceeds the set threshold for 30 seconds, the 'High Return Humidity' event will be triggered.

Line #4: Enables the 'Low Return Humidity' event.

Line #5: Defines the threshold for Low Return Humidity. If the actual return humidity falls below the set threshold for 30 seconds, the 'Low Return Humidity' event will be triggered.

High/Low Limits menu page 5 of 5

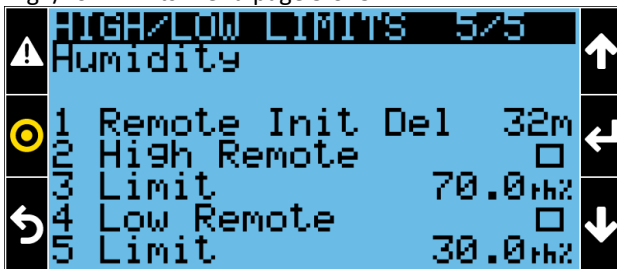

Line #1: The (auto-reset) events are ignored at unit ON for the duration set by this parameter.

Line #2: Enables the 'High Remote Humidity' event.

Line #3: Defines the threshold for High Remote Humidity. If the actual remote humidity exceeds the set threshold for 30 seconds, the 'High Remote Humidity' event will be triggered.

Line #4: Enables the 'Low Remote Humidity' event.

Line #5: Defines the threshold for Low Remote Humidity. If the actual remote humidity falls below the set threshold for 30 seconds, the 'Low Remote Humidity' event will be triggered.

An additional page is displayed when the static pressure sensor is enabled.

2.5.3 Total Run Hours



Total Run Hours menu page 1 of 6

TOTAL RUN HOURS 1/6		Act.	Thr.	Res
1	Fan	148	0	<input type="checkbox"/>
2	CW1	0	0	<input type="checkbox"/>
3	CW2	0	0	<input type="checkbox"/>

Line #1: Displays the current fan run hours counter and the associated user-settable threshold. If the operating hours exceed this threshold, the 'Conditioner/Fans Working Hours Exceeded' event will be triggered.

Line #2: Displays the current run hours counter for CW valve circuit 1 and the associated user-settable threshold. If the operating hours exceed this threshold, the 'CW1 Valve Working Hours Exceeded' event will be triggered.

Line #3: Displays the current run hours counter for CW valve circuit 2 and the associated user-settable threshold. If the operating hours exceed this threshold, the 'CW2 Valve Working Hours Exceeded' event will be triggered.

The current run hours can be reset to 0 by checking the 'Res' checkbox.

If the threshold is set to 0, the event will not be generated.

Total Run Hours menu page 2 of 6

TOTAL RUN HOURS 2/6		Act.	Thr.	Res
1	CMP1C1	113	0	<input type="checkbox"/>
2	CMP2C1	0	0	<input type="checkbox"/>
3	CMP1C2	0	0	<input type="checkbox"/>
4	CMP2C2	0	0	<input type="checkbox"/>

Line #1: Displays the current run hours counter for Compressor 1 Circuit 1 and the associated user-settable threshold. If the operating hours exceed this threshold, the 'Comp1 Circ1 Working Hours Exceeded' event will be triggered.

Line #2: Displays the current run hours counter for Compressor 2 Circuit 1 and the associated user-settable threshold. If the operating hours exceed this threshold, the 'Comp2 Circ1 Working Hours Exceeded' event will be triggered.

Line #3: Displays the current run hours counter for Compressor 1 Circuit 2 and the associated user-settable threshold. If the operating hours exceed this threshold, the 'Comp1 Circ2 Working Hours Exceeded' event will be triggered.

Line #4: Displays the current run hours counter for Compressor 2 Circuit 2 and the associated user-settable threshold. If the operating hours exceed this threshold, the 'Comp2 Circ2 Working Hours Exceeded' event will be triggered.

The current run hours can be reset to 0 by checking the 'Res' checkbox.

If the threshold is set to 0, the event will not be generated.

Total Run Hours menu page 3 of 6

TOTAL RUN HOURS 3/6		Act.	Thr.	Res
1	FC	13	0	<input type="checkbox"/>
2	AirEco	0	0	<input type="checkbox"/>
3	PUMP 1	0	0	<input type="checkbox"/>
4	PUMP 2	0	0	<input type="checkbox"/>

Line #1: Displays the current Fluid Economizer run hours counter and the associated user-settable threshold. If the operating hours exceed this threshold, the 'FC Working Hours Exceeded' event will be triggered.

Line #2: Displays the current Air Economizer run hours counter and the associated user-settable threshold. If the operating hours exceed this threshold, the 'AirEco Working Hours Exceeded' event will be triggered.

Line #3: Displays the current run hours counter for EconoPhase Pump circuit 1 and the associated user-settable threshold. If the operating hours exceed this threshold, the 'PRE1 Working Hours Exceeded' event will be triggered.

Line #4: Displays the current run hours counter for EconoPhase Pump circuit 2 and the associated user-settable threshold. If the operating hours exceed this threshold, the 'PRE2 Working Hours Exceeded' event will be triggered.

The current run hours can be reset to 0 by checking the 'Res' checkbox.

If the threshold is set to 0, the event will not be generated.

Total Run Hours menu page 4 of 6

TOTAL RUN HOURS 4/6		Act.	Thr.	Res
1	Cond1	113	0	<input type="checkbox"/>
2	Cond2	0	0	<input type="checkbox"/>
3	Hum	1	0	<input type="checkbox"/>
4	Deh	0	0	<input type="checkbox"/>

Line #1: Displays the current run hours counter for Condenser Fans Circuit 1 and the associated user-settable threshold. If the operating hours exceed this threshold, the 'Condenser Fans1 Working Hours Exceeded' event will be triggered.

Line #2: Displays the current run hours counter for Condenser Fans Circuit 2 and the associated user-settable threshold. If the operating hours exceed this threshold, the 'Condenser Fans2 Working Hours Exceeded' event will be triggered.

Line #3: Displays the current run hours counter for the Humidifier and the associated user-settable threshold. If the operating hours exceed this threshold, the 'Humidifier Working Hours Exceeded' event will be triggered.

Line #4: Displays the current run hours counter for Dehumidification and the associated user-settable threshold. If the operating hours exceed this threshold, the 'Dehumidification Working Hours Exceeded' event will be triggered. The current run hours can be reset to 0 by checking the 'Res' checkbox.

If the threshold is set to 0, the event will not be generated.

Total Run Hours menu page 5 of 6

TOTAL RUN HOURS 5/6		Act.	Thr.	Res
1	Heat1	0	0	<input type="checkbox"/>
2	Heat2	0	0	<input type="checkbox"/>
3	HotG/W	0	0	<input type="checkbox"/>
4	EEV1	126	0	<input type="checkbox"/>
5	EEV2	0	0	<input type="checkbox"/>

Line #1: Displays the current run hours counter for the first step of the Electrical Heater and the associated user-settable threshold. If the operating hours exceed this threshold, the 'El. Heater1 Working Hours Exceeded' event will be triggered.

Line #2: Displays the current run hours counter for the second step of the Electrical Heater and the associated user-settable threshold. If the operating hours exceed this threshold, the 'El. Heater2 Working Hours Exceeded' event will be triggered.

Line #3: Displays the current run hours counter for the Hot Gas (DX) or Hot Water (CW) system and the associated user-settable threshold. If the operating hours exceed this threshold, the 'Hot Water/Gas Working Hours Exceeded' event will be triggered.

Line #4: Displays the current run hours counter for EEV Circuit 1 and the associated user-settable threshold. If the operating hours exceed this threshold, the 'EEV Circuit 1 Working Hours Exceeded' event will be triggered.

Line #5: Displays the current run hours counter for EEV Circuit 2 and the associated user-settable threshold. If the operating hours exceed this threshold, the 'EEV Circuit 2 Working Hours Exceeded' event will be triggered.

The current run hours can be reset to 0 by checking the 'Res' checkbox.

If the threshold is set to 0, the event will not be generated.

Total Run Hours menu page 6 of 6

TOTAL RUN HOURS 6/6		Act.	Res
1	Unit On	1	<input type="checkbox"/>
2	Mech Cool	1	<input type="checkbox"/>
3	Freecool	0	<input type="checkbox"/>
4	Mech&FC	0	<input type="checkbox"/>

Line #1: Displays the current air conditioner run hours counter.

Line #2: Displays the current mechanical cooling-only run hours counter.

Line #3: Displays the current freecooling-only run hours counter.

Line #4: Displays the current run hours counter for simultaneous operation of mechanical cooling and freecooling.

The current run hours can be reset to 0 by checking the 'Res' checkbox.

There are no thresholds for these counters.

2.5.4 Scheduler



Scheduler menu page 1 of 3

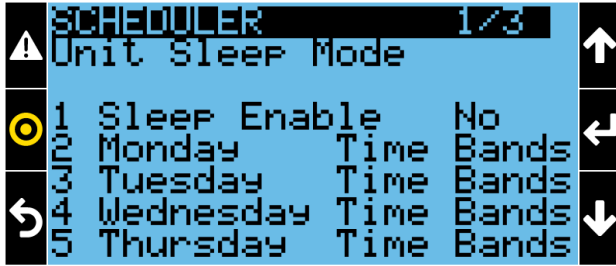

Line #1: Enables/disables the Sleep Mode function. If set to 'No', the unit will never enter in Sleep Mode.

Line #2: If set to 'Always OFF', the unit will enter in Sleep Mode throughout the entire day (Monday).

Line #3: If set to 'Always OFF', the unit will enter in Sleep Mode throughout the entire day (Tuesday).

Line #4: If set to 'Always OFF', the unit will enter in Sleep Mode throughout the entire day (Wednesday).

Line #5: If set to 'Always OFF', the unit will enter in Sleep Mode throughout the entire day (Thursday).

Scheduler menu page 2 of 3

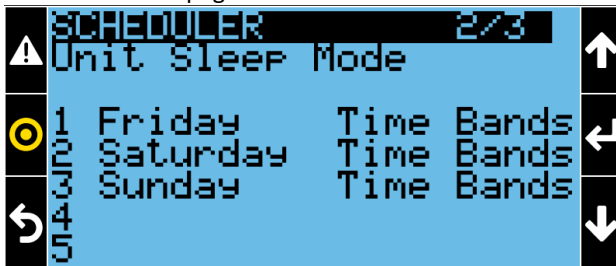

Line #1: If set to 'Always OFF', the unit will enter in Sleep Mode throughout the entire day (Friday).

Line #2: If set to 'Always OFF', the unit will enter in Sleep Mode throughout the entire day (Saturday).

Line #3: If set to 'Always OFF', the unit will enter in Sleep Mode throughout the entire day (Sunday).

Scheduler menu page 3 of 3

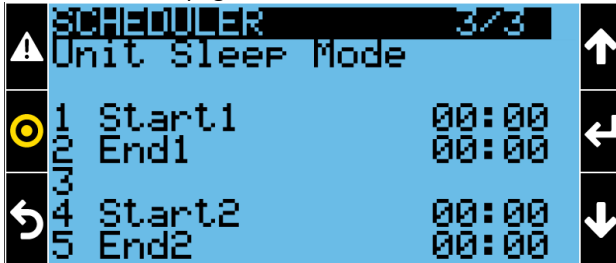

Line #1: Specifies, for days configured as Time Bands, the start time of the sleep mode (first interval).

Line #2: Specifies, for days configured as Time Bands, the end time of the sleep mode (first interval).

Line #4: Specifies, for days configured as Time Bands, the start time of the sleep mode (second interval).

Line #5: Specifies, for days configured as Time Bands, the end time of the sleep mode (second interval).

2.5.5 Condenser (DX Air Cooled only)



Condenser menu page 1 of 4

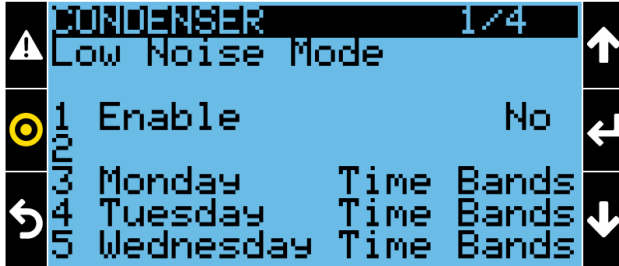

Line #1: Enables/disables Low Noise Mode. If set to 'No', the condenser will never enter in Low Noise Mode. Low Noise Mode limits the maximum speed of the condenser fans to reduce noise.

Line #3: If set to 'Whole Day', the condenser will be in Low Noise Mode throughout the entire day (Monday).

Line #4: If set to 'Whole Day', the condenser will be in Low Noise Mode throughout the entire day (Tuesday).

Line #5: If set to 'Whole Day', the condenser will be in Low Noise Mode throughout the entire day (Wednesday).

Condenser menu page 2 of 4

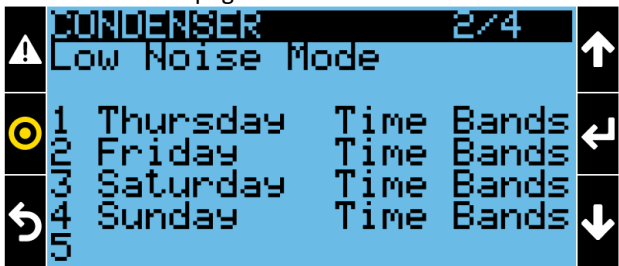

Line #1: If set to 'Whole Day', the condenser will be in Low Noise Mode throughout the entire day (Thursday).

Line #2: If set to 'Whole Day', the condenser will be in Low Noise Mode throughout the entire day (Friday).

Line #3: If set to 'Whole Day', the condenser will be in Low Noise Mode throughout the entire day (Saturday).

Line #4: If set to 'Whole Day', the condenser will be in Low Noise Mode throughout the entire day (Sunday).

Condenser menu page 3 of 4

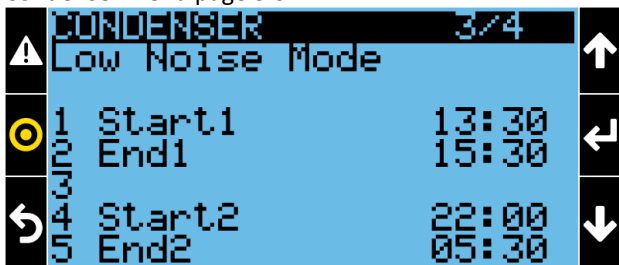

Line #1: Specifies, for days configured as Time Bands, the start time of Low Noise Mode (first interval).

Line #2: Specifies, for days configured as Time Bands, the end time of Low Noise Mode (first interval).

Line #4: Specifies, for days configured as Time Bands, the start time of Low Noise Mode (second interval).

Line #5: Specifies, for days configured as Time Bands, the end time of Low Noise Mode (second interval).

Condenser menu page 4 of 4

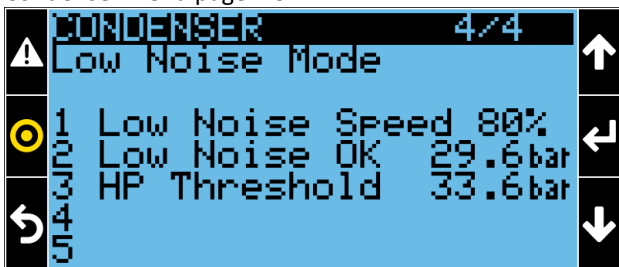

Line #1: Specifies the maximum condenser fan speed when in Low Noise Mode.

Line #2: Specifies the pressure threshold; if the actual pressure falls below this threshold, Low Noise Mode is allowed to start.

Line #3: Interrupts Low Noise Mode if the actual pressure is at or above the specified threshold. The 'Low Noise Speed' is ignored, and the condenser control returns to normal operation.

2.5.6 Display Options



Display Options menu page 1 of 3

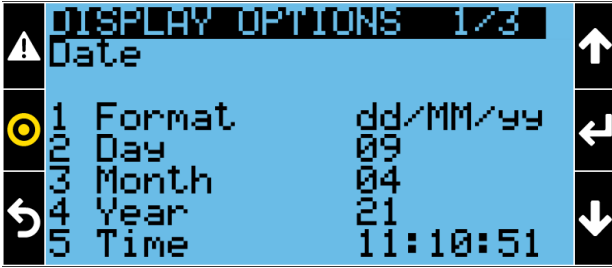

Line #1: Specifies the date format type: dd/MM/yy (Day/Month/Year), MM/dd/yy (Month/Day/Year), yy-MM-dd (Year/Month/Day), dd.MM.yy (Day/Month/Year), and yy/MM/dd (Year/Month/Day).

Lines #2 #3 #4: Set the date (day, month, and year).

Lines #5: Set the time (hours, minutes, and seconds).

Display Options menu page 2 of 3

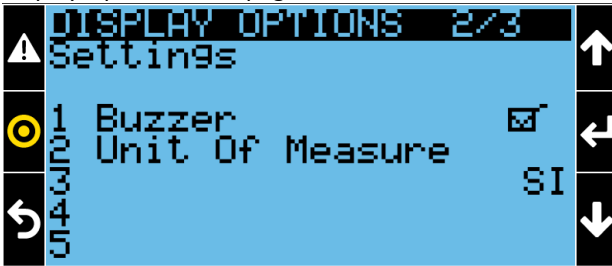

Line #1: Enables/Disables the audible signal (buzzer).

Line #2: Sets the system of measurement (Metric or Imperial).

Display Options menu page 3 of 3

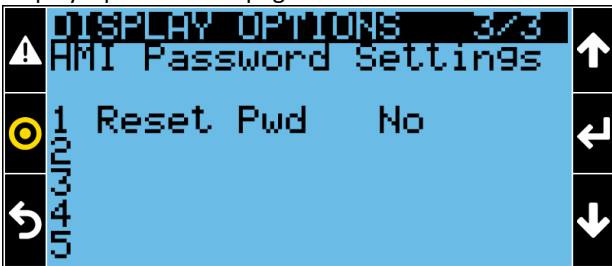

The Touch Display password can be changed. The Small Display password (local device) is hard-coded.

Line #1: Resets the Touch Display password to its default value.

2.5.7 Logout



Logout menu

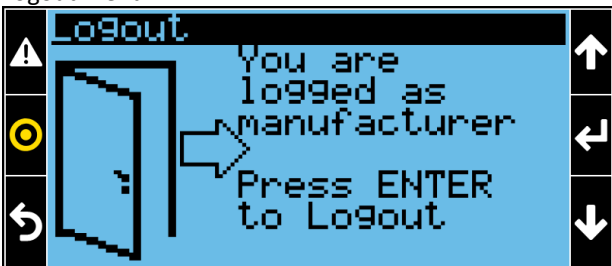

From this menu, pressing the Enter Key (↵) logs the user out.

2.6 Unit Overview

Unit Overview icons view

1 of 2



2 of 2

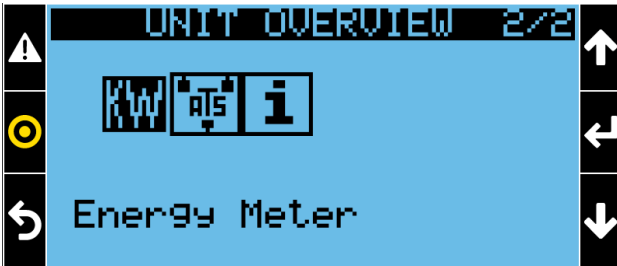

From the Main Screen, press the Decrease (⏮) Key to access the Unit Overview. A password is not required.

2.6.1 Sensors



Sensors page 1 of 2

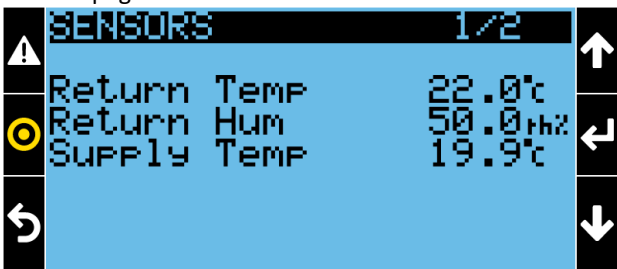

This page displays return temperature, return humidity, and supply temperature values. In the case of multiple sensors, these values represent the minimum, maximum, or average value based on the configured method. Additional values, such as remote temperature/humidity, Air Economizer temperature/humidity, CW inlet/outlet temperatures, or other sensors, will be shown if the related sensor is enabled.

If the AAT function is enabled, the Auxiliary Aggregated Temperature (AAT) value will also be displayed.

Sensors page 2 of 2

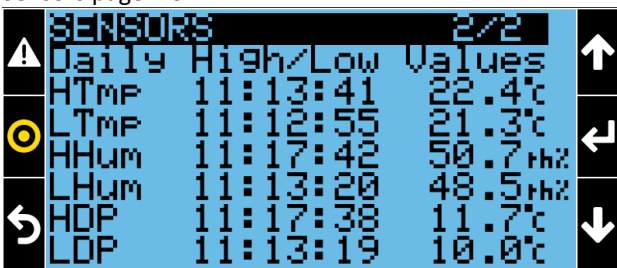

This page displays the daily high (H) and low (L) values, including the corresponding times, for the control temperature (HTmp/LTmp), return humidity (HHum/LHum), and dew point (HDP/LDP).

2.6.2 Fans



Fans page 1 of 1

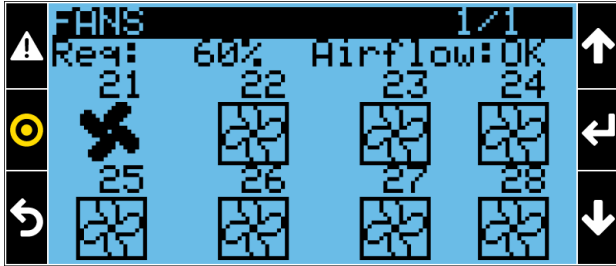

The percentage represents the fan speed request.

The airflow contact (OK/NOK), if connected, provides information about the status of the airflow signal, where NOK indicates Fan Failure.

The icons indicate the status of each Modbus fan:

Icon	Description
	Evaporating Fan x Ok and Running
	Evaporating Fan x Ok Not Running
	Evaporating Fan x Not Available
	Evaporating Fan x Communication Failure
	Evaporating Fan x Failure

If Static Pressure control is enabled, an additional page displaying the pressure value, setpoint, and dead band will be shown.

If airflow rate measurement is enabled, an additional page with the airflow rate will be displayed.

2.6.3 Compressors



Note: The Compressors menu will be locked for CW unit.

Compressors page 1 of 2

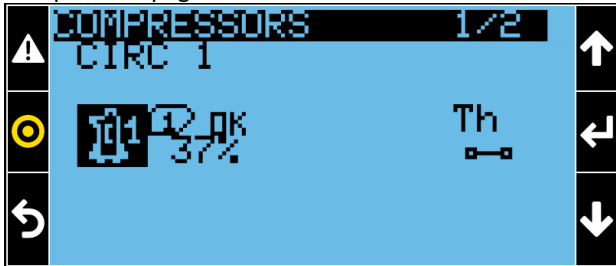

The compressor icon (A) indicates the status of the compressor:

Icon	Description
	Compressor ON
	Compressor OFF
	Compressor in Alarm

The percentage represents the compressor modulation value. For fixed compressors, it can be 0% (Comp OFF) or 100% (Comp ON).



Indicates the current envelope working zone. '1' signifies operation within operating limits.

'TON': A counter indicating the remaining minimum On time for the compressor (starts at compressor ON). No indication means the minimum On time has elapsed.

'TOFF': A counter indicating the remaining minimum Off time for the compressor (starts at compressor OFF). No indication means the minimum Off time has elapsed.

'Th' contact (—): Provides information about the compressor thermal protection: Close = OK, Open = TH Alarm. For Tandem compressors, the same information will be displayed for compressor #2.

Compressors page 2 of 2

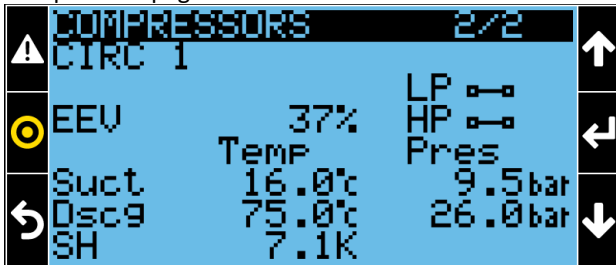

The percentage represents the EEV opening request.

'LP' contact (—): Provides information about the Low-pressure condition: Close = OK, Open = LP Alarm.

'HP' contact (—): Provides information about the status of the High-pressure switch: Close = OK, Open = HP Alarm.

Other displayed values include suction temperature and pressure, discharge temperature (optional), pressure, and superheat (SH).

In the case of a double circuit unit, the same information will be displayed for the second circuit (on pages 3 and 4).

2.6.4 Condensers



Note: The Condensers menu will be locked for CW unit.

Air Cooled

Condensers page 1 of 1

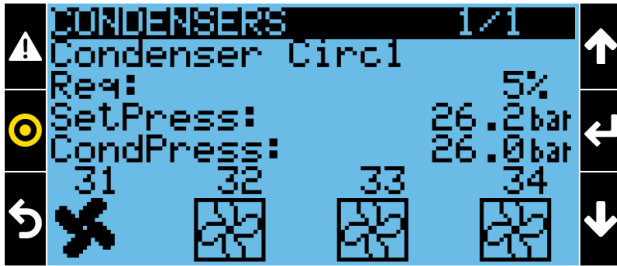

Req: Represents the fan speed request.

SetPress (or **SetTemp**): Represents the current condenser setpoint value (Pressure or refrigerant temperature).

CondPress (or **CondTemp**): Represents the condenser pressure (or refrigerant temperature) value:

Icon	Description
	Condensing Fan x Circuit 1 Ok and Running
	Condensing Fan x Circuit 1 Ok Not Running
	Condensing Fan x Circuit 1 Not Available
	Condensing Fan x Circuit 1 Communication Failure
	Condensing Fan x Circuit 1 Failure

For a double circuit unit, the same information will be displayed for the second circuit.

Water Cooled

Condensers page 1 of 1

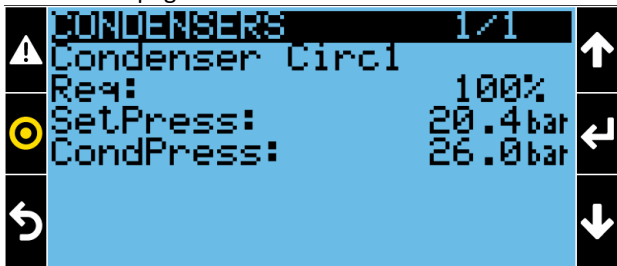

Req: Represents the condenser valve opening request.

SetPress: Represents the current condenser pressure setpoint value.

CondPress: Represents the condenser pressure value.

For a double circuit unit, the same information will be displayed for the second circuit.

2.6.5 Heating



Note: The Heating menu will be locked if this option is unavailable.

Heating page 1 of 1

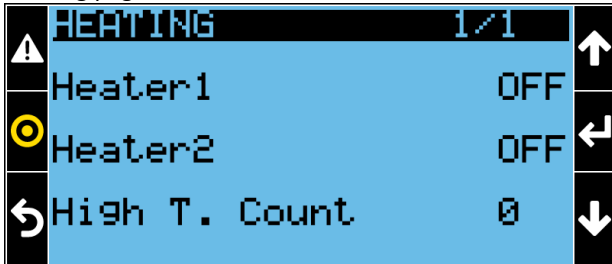

Heater 1 indicates the status of the electrical heating first step (On or Off).

Heater 2 indicates the status of the electrical heating second step (On or Off).

High T. Count: If the current Supply Temperature for Fan Safety is at or above the threshold (40°C), then the electrical heaters will be stopped for 2 hours, and this counter will be increased by 1. A rolling 24-hour timer will be applied: if this counter reaches 3 within 24 hours, the electrical heater will be turned off; the electrical heaters can restart only if the counter is reset (Service/Options/El. Heater menu).

2.6.6 Hum/Dehum



Note: The Hum/Dehum menu will be locked if this option is unavailable.

Hum/Dehum (External Humidifier) page 1 of 2

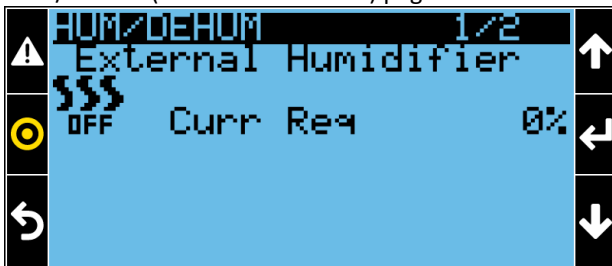

The icon (SSS) displays the status of the humidifier (On or Off).

Curr Req indicates the current humidification request as a percentage.

In the case of an electrode or infrared humidifier, additional information will be displayed.

Hum/Dehum (Dehumidification) page 2 of 2

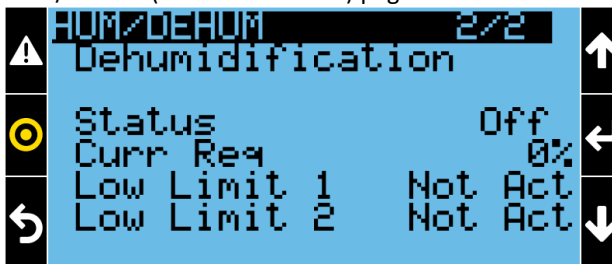

Status indicates the status of dehumidification (On or Off).

Curr Req indicates the current dehumidification request as a percentage.

Low Limit 1 provides information about the status of Low Limit 1 (Active or Not Active). Low Limit 1 will disable one of the two compressors (or circuit in the case of tandem compressors) set for dehumidification. If only 1 compressor/circuit is set for dehumidification, or the dehumidification source is chilled water, this limit will not be considered.

Low Limit 2 provides information about the status of Low Limit 2 (Active or Not Active). Low Limit 2 will disable all the cooling sources (compressors or chilled water) set for dehumidification.

2.6.7 Chilled Water



Note: The Chilled Water menu will be locked for DX unit.

Chilled Water page 1 of 1

CHILLED WATER 1/1	
▲	Main Valve 1
	OP Mode Parallel
●	Req% CW1 40 CW2 40
	l/s 0.90 0.34
↶	kW 33.8 25.2

Main Valve indicates the first activated CW valve (double circuit unit) in Cascade mode or the designated CW valve to run in Alternate mode.

OP Mode indicates the CW operating mode with the following options:

- Single = One CW circuit only.
- Parallel (double circuit) = Both valves are controlled simultaneously with the same logic.
- Alternate (double circuit) = Only one hydraulic circuit can run, with the 'Main Valve' parameter defining priority.
- Cascade (double circuit) = The main valve (defined by the 'Main Valve' parameter) covers the first 70% of the request; the second valve engages only if the request exceeds this threshold. If the request drops below 50%, only the main valve operates, and the second valve closes.

Req% indicates the opening request for CW valves 1 and 2 in percentage.

l/s or m3/h represents the volumetric water flow for each circuit (l/s or m3/h).

kW is the cooling gross capacity (per circuit), calculated by the control based on volumetric water flow and inlet/outlet water temperatures.

If Supersaver is enabled, the Supersaver signal will be displayed.

Additional values are shown if Modbus valve feedback reading is enabled.

2.6.8 Fluid Economizer



Note: The Fluid Economizer menu will be locked if the option is unavailable.

Fluid Economizer page 1 of 1

FLUID ECONOMIZER 1/1	
▲	FC Request 21%
	FC Status ON
●	DT1 Status OK
	DT2 Status OK
	DT3 Status OK
↶	Lockout FC No
	Lockout Comp No

FC Request indicates the opening request of the Fluid Economizer valve (0-100%).

FC Status provides information on the Fluid Economizer's operating status:

- START = DT1 (if enabled) is true.
- ON = The Fluid Economizer (FC valve) is currently in operation.
- OFF = The Fluid Economizer (FC valve) is closed.

DT1 Status represents the status of the temperature difference between the return temperature and outdoor temperature.

DT2 Status represents the status of the temperature difference between the control temperature and glycol temperature.

DT3 Status represents the status of the temperature difference between the control temperature and control setpoint.

The status (OK/NOK) of the DTs is overwritten during forcing conditions (e.g., Force FC) or if the Fluid Economizer is locked out.

Lockout FC indicates whether the Fluid Economizer is currently locked out.

Lockout Comp indicates whether the compressor(s) is currently locked out.

2.6.9 Air Economizer



Note: The Air Economizer menu will be locked if the option is unavailable.

Air Economizer page 1 of 2

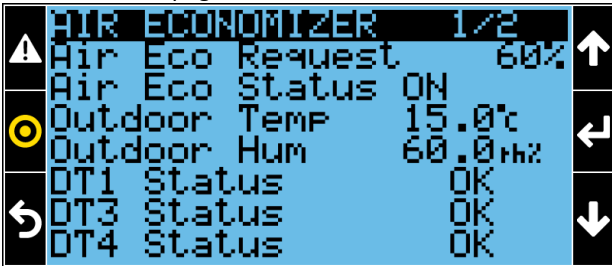

Air Eco Request indicates the opening request of the Air Economizer damper (outdoor) in the range of 0-100%.

Air Eco Status provides information on the status of the Air Economizer:

- ON = The Air Economizer damper (outdoor) is open (>0%).
- Emerg = The Air Economizer damper (outdoor) is open (>0%) due to Emergency Override. This override occurs when the return temperature exceeds an adjustable high temperature threshold, resulting in the opening of the outdoor air damper and the closure of the indoor air damper.
- OFF = The Air Economizer damper (outdoor) is closed (0%).

Outdoor Temp displays the outdoor temperature value.

Outdoor Hum displays the outdoor humidity value.

DT1 Status represents the status of the temperature difference between the return temperature and outdoor temperature.

DT3 Status represents the status of the temperature difference between the control temperature and control setpoint.

DT4 Status represents the status of the humidity ratio and wet bulb temperature.

The status (OK/NOK) of the DTs is overwritten during forcing conditions (e.g., Force FC) or if the Air Economizer is locked out.

Air Economizer page 2 of 2

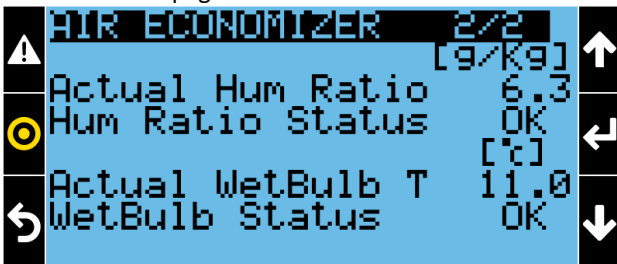

Actual Hum Ratio displays the humidity ratio value (g/Kg).

Hum Ratio Status indicates the status of the humidity ratio, considering the minimum and maximum thresholds set.

Actual WetBulb T displays the wet bulb temperature value (°C).

WetBulb Status indicates the status of the wet bulb temperature, considering the minimum threshold set.

2.6.10 EconoPhase



Note: The EconoPhase menu will be locked if the option is unavailable.

EconoPhase page 1 of 2

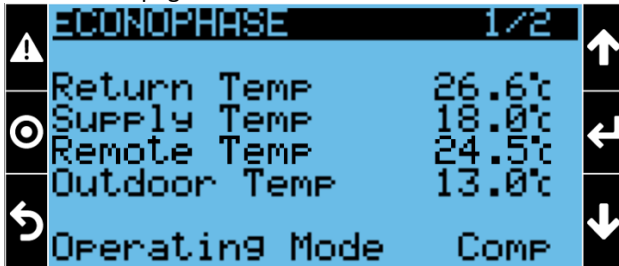

Return Temp displays the return temperature value.

Supply Temp displays the supply temperature value.

Remote Temp displays the remote temperature value.

Outdoor Temp displays the outdoor temperature value (maximum value between Circuit 1 and 2).

Operating Mode indicates the current operating mode of EconoPhase:

- Comp = The unit can run in pure DX mode only.
- Mix = Circuit 1 is running in Pump mode, while Circuit 2 is running in DX mode.
- Pump = The unit can run in pure Pump mode.

EconoPhase page 2 of 2

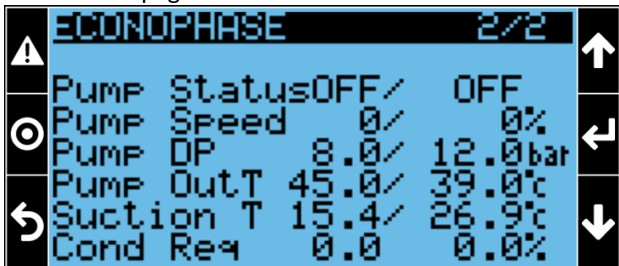

Pump Status represents the status (ON or OFF) of Pump 1 (first value) and Pump 2 (second value).

Pump Speed indicates the speed in percentage of Pump 1 (first value) and Pump 2 (second value).

Pump DP indicates the differential pressure of Pump 1 (first value) and Pump 2 (second value).

Pump OutT indicates the outlet refrigerant temperature of Pump 1 (first value) and Pump 2 (second value).

Suction T indicates the suction temperature of Circuit 1 (first value) and Circuit 2 (second value).

Cond Req indicates the fan speed of Condenser 1 (first value) and Condenser 2 (second value).

2.6.11 Inputs



Inputs page 1 of 4

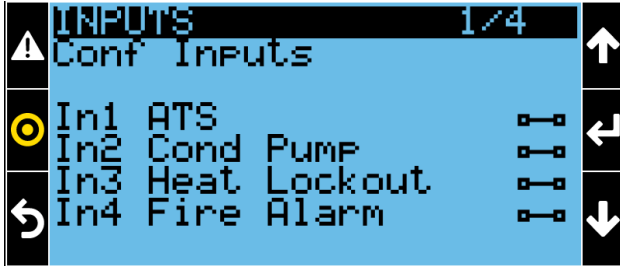

In1 provides information about the status of Configurable Input 1 set as ATS (Automatic Transfer Switch). It indicates which power supply (1 or 2) is feeding the unit: Closed = Power Supply 1; Open = Power Supply 2. This input is configurable.

In2 provides information about the status of Configurable Input 2 set as Cond Pump (Condensate Pump): Closed = OK; Open = Condensing Pump Alarm. This input is configurable.

In3 provides information about the status of Configurable Input 3 set as Heater Alarm: Closed = OK; Open = Heater Alarm. This input is configurable if the electrical heaters are not installed.

In4 provides information about the status of Configurable Input 4 set as Fire Alarm: Closed = OK; Open = Fire Alarm. This input is configurable.

Inputs page 2 of 4

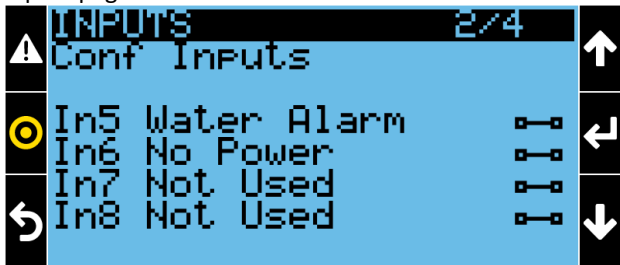

In5 provides information about the status of Configurable Input 5 set as Water Alarm: Closed = OK; Open = Water Alarm. This input is configurable.

In6 provides information about the status of Configurable Input 6 set as No Power: Closed = Main power supply OK; Open = Main power supply is missing. This input is configurable.

In7 provides information about the status of Configurable Input 7: Closed = Inactive; Open = Active. This input is configurable.

In8 provides information about the status of Configurable Input 8: Closed = Inactive; Open = Active. This input is configurable.

Inputs page 3 of 4

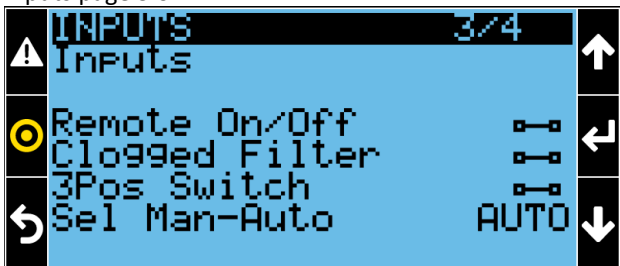

Remote On/Off provides information about the status of the Remote On/Off switch: Closed = Unit is ON (if the other conditions are satisfied); Open = Unit is OFF (Remote OFF).

Clogged Filter provides information about the status of the digital Clogged Filter device: Closed = OK; Open = Clogged Filter warning.

3Pos Switch provides information about the ON/OFF status of the 3 Position Switch: Closed = Unit is ON (if the other conditions are satisfied); Open = Unit is OFF.

Sel Man-Auto provides information about the status of the 3 Position Switch: MAN = Fan and cooling are forced to 100%; AUTO = Unit is running in automatic mode; OFF = Unit is OFF.

Inputs page 4 of 4

INPUTS		4/4
Customer Analog Inputs		
Analogue In 1		23.0°C
Analogue In 2		37.0bar
Analogue In 3		0.0
Analogue In 4		0.0

Customer Analog Inputs: There are up to 4 analog inputs that customers can utilize to convert an analog signal into physical values. These inputs are read from expansion board #2. The resulting values have no control functionality or alarms; they are for visualization purposes only.

2.6.12 Outputs



Outputs page 1 of 1

OUTPUTS		1/1
Out1	FANVSD	50%
Out2	COND1	5%
Out3	HUMI	0%
Out4	- N.A.-	0%
Out5	- N.A.-	0%

Out1 displays the setting (FANVSD) and value in percentage for analog output 1 (e.g., 40% = 4.0 Volt).

Out2 displays the setting (COND1) and value in percentage for analog output 2.

Out3 displays the setting (HUMI) and value in percentage for analog output 3.

Out4 displays the setting and value in percentage for analog output 4. Not available for DX single circuit and CW units.

Out5 displays the setting and value in percentage for analog output 5. Not available for DX single circuit and CW units.

2.6.13 Energy Meter



Note: The Energy Meter menu will be locked if the option is unavailable.

Energy Meter page 1 of 4

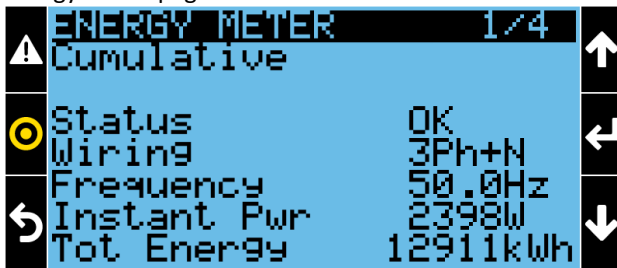

Status indicates the status of the energy meter: OFF, OK, Unknown, CommErr, and Disconn.

Wiring indicates the power supply connection type: 3Ph+N, 1Ph+N, 2Ph+N, and 3PH.

Frequency displays the actual frequency (Hz).

Instant Pwr displays the instant power consumption (W).

Tot Energy displays the total power consumption (KWh).

Energy Meter page 2 of 4

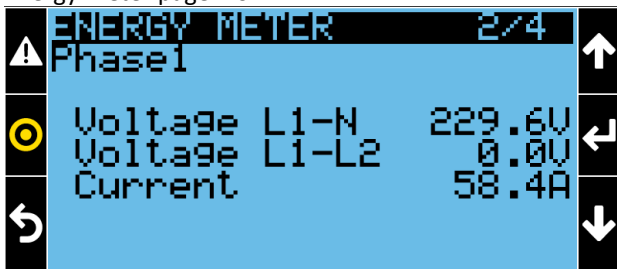

Voltage L1-N displays the actual Line 1 and Neutral voltages (V).

Voltage L1-L2 displays the actual Line 1 to Line 2 voltages (V).

Current displays the actual phase 1 current value (A).

Energy Meter page 3 of 4

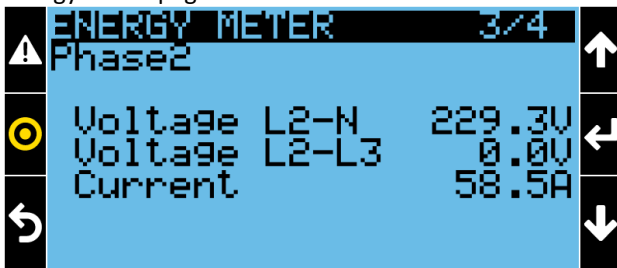

Voltage L2-N displays the actual Line 2 and Neutral voltages (V).

Voltage L2-L3 displays the actual Line 2 to Line 3 voltages (V).

Current displays the actual phase 2 current value (A).

Energy Meter page 4 of 4

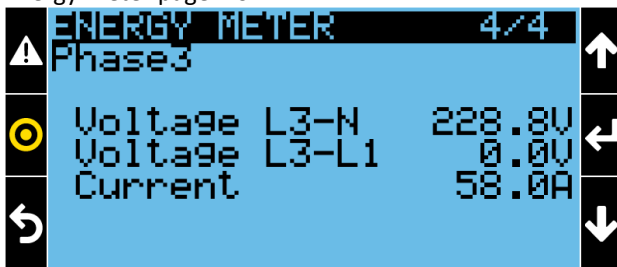

Voltage L3-N displays the actual Line 3 and Neutral voltages (V).

Voltage L3-L1 displays the actual Line 3 to Line 1 voltages (V).

Current displays the actual phase 3 current value (A).

2.6.14 ATS



Note: The ATS menu will be locked if the option is unavailable.

ATS page 1 of 3

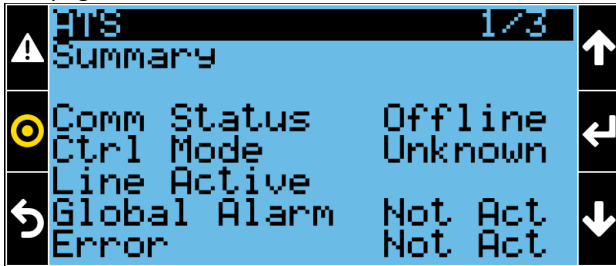

Comm Status indicates the status of the ATS: Offline, Online.

Ctrl Mode indicates the ATS working mode: Unknown, Off, Manual, Auto, Test.

Line active indicates which power supply line (1 or 2) is feeding the unit.

Global Alarm indicates if the ATS is in alarm (Act).

Error indicates if the ATS is in error (Act).

ATS page 2 of 3

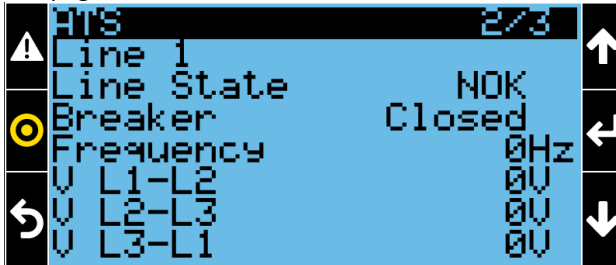

Line 1

Line Status indicates whether the power supply 1 is present (OK) or not (NOK).

Breaker indicates the status of the breaker: Closed, Alarm, Unknown, Command, Close Cmd, Open Cmd.

Frequency displays the actual frequency (Hz).

V L1-L2 displays the actual Line 1 to Line 2 voltages (V).

V L2-L3 displays the actual Line 2 to Line 3 voltages (V).

V L3-L1 displays the actual Line 3 to Line 1 voltages (V).

ATS page 3 of 3

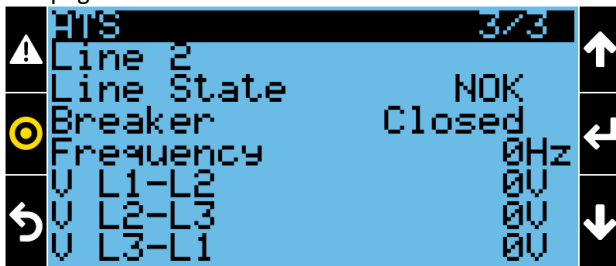

Line 2

Line Status indicates whether the power supply 2 is present (OK) or not (NOK).

Breaker indicates the status of the breaker: Closed, Alarm, Unknown, Command, Close Cmd, Open Cmd.

Frequency displays the actual frequency (Hz).

V L1-L2 displays the actual Line 1 to Line 2 voltages (V).

V L2-L3 displays the actual Line 2 to Line 3 voltages (V).

V L3-L1 displays the actual Line 3 to Line 1 voltages (V).

2.6.15 Unit Info



Unit Info page 1 of 1

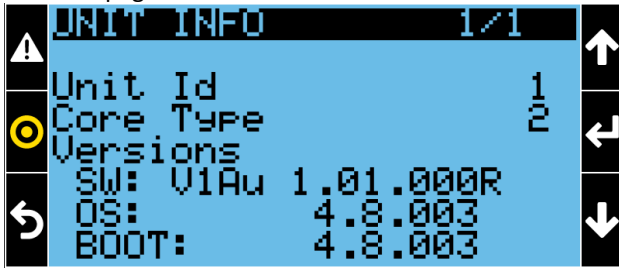

Unit Id indicates the Unit Identification number in the case of networking.

Core Type indicates the core type of the unit control board.

SW: displays the software version installed on the unit control board.

OS: displays the operating system version installed on the unit control board.

BOOT: displays the boot loader version installed on the unit control board.

2.7 System Overview

System Overview page 1 of 8

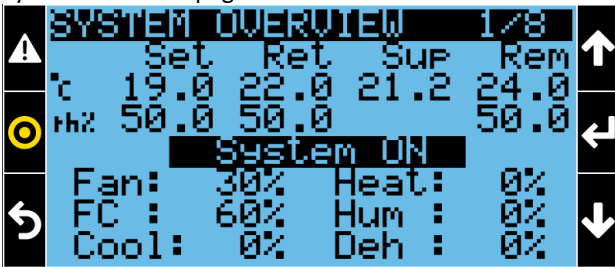

From the Main Screen, press the Increase (▲) Key to access the System Overview. A password is not required. This page displays:

- The system status (ON/OFF). In Teamwork Mode 0 (No Teamwork) and without standby units, this status should not be considered.
- The system current setpoint for temperature and humidity (Set). In Teamwork Mode 0 (No Teamwork), these values should not be considered.
- The system values for return temperature (Ret), return humidity (Ret), supply temperature (Sup), remote temperature (Rem), and remote humidity (Rem).
- The system percentage utilization of fans (Fan), free cooling (FC), compressor or CW valve (Cool), and heating (Heat). The system percentage deviation for humidification (Hum) and dehumidification (Deh) when active.

System Overview page 2 of 8

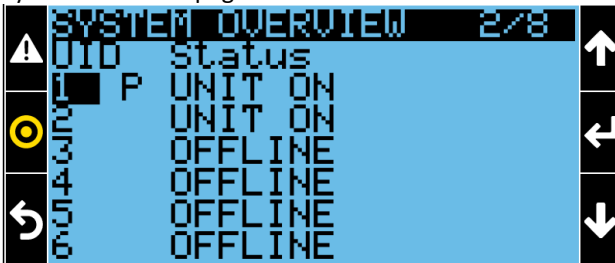

This page displays the status (On, Off, Standby, etc.) of each unit in the system, numbered from 1 to 6. 'P' indicates the primary unit in the system.

System Overview page 3 of 8

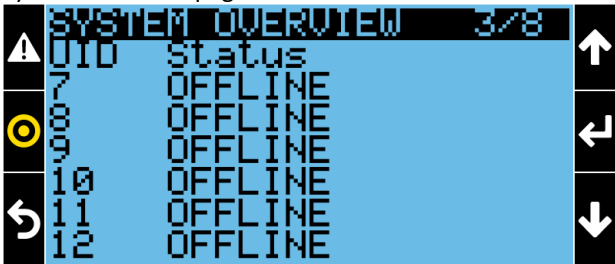

This page displays the status (On, Off, Standby, etc.) of each unit in the system, numbered from 7 to 12.

System Overview page 4 of 8

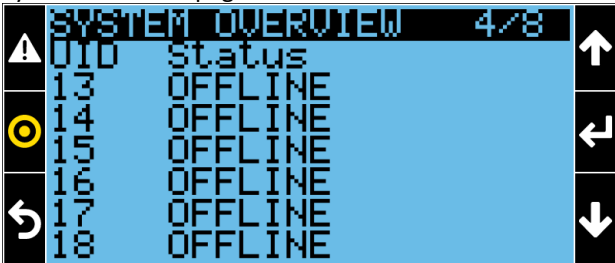

This page displays the status (On, Off, Standby, etc.) of each unit in the system, numbered from 13 to 18.

System Overview page 5 of 8

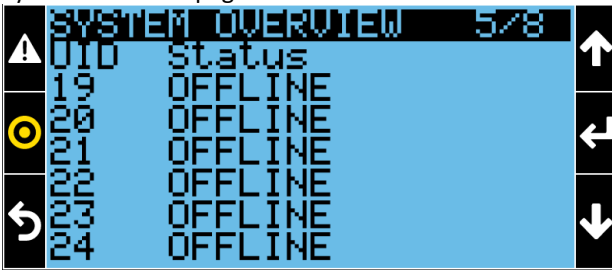

This page displays the status (On, Off, Standby, etc.) of each unit in the system, numbered from 19 to 24.

System Overview page 6 of 8

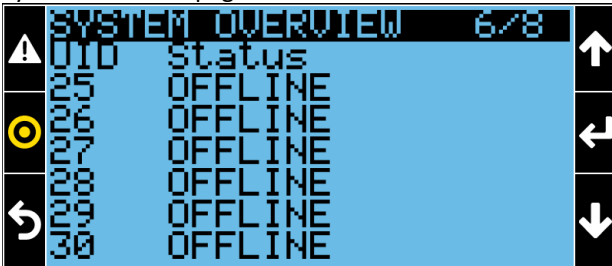

This page displays the status (On, Off, Standby, etc.) of each unit in the system, numbered from 25 to 30.

System Overview page 7 of 8

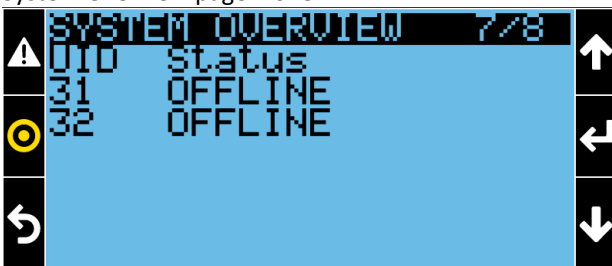

This page displays the status (On, Off, Standby, etc.) of each unit in the system, numbered 31 and 32.

System Overview page 8 of 8

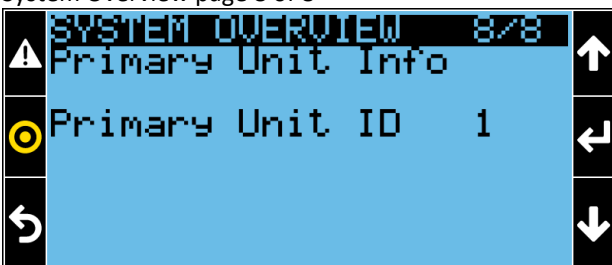

The Primary Unit Info indicates the primary unit of the system.

2.8 Events Report

Events Report icons view



Press the Alarm (▲) Key to open the Events Report window. A password is not necessary.

2.8.1 Active Events



Active Events List page 1 of x

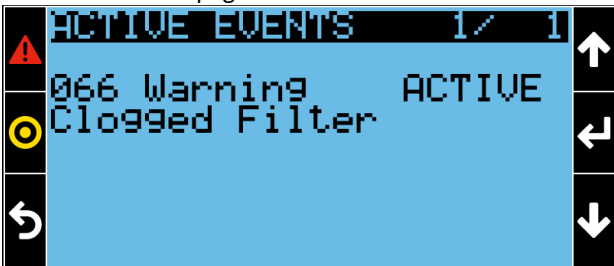

Press the Alarm (▲) Key or the Enter Key (↵) to access the Active Events menu.

This menu lists all warnings and alarms currently active. Each entry includes:

- Event ID (in this case 066)
- Event type (in this case Warning)
- Event status (in this case ACTIVE)
- Event description (in this case Clogged Filter)

When an alarm or warning condition is triggered, audible and visible indicators activate. After fixing the fault condition, reset the event by accessing the Active Events menu and holding the Alarm Key (▲) for three seconds. Press the Enter Key (↵), to select a single event and then reset it.

2.8.2 Status Report



Status Report page 1 of x

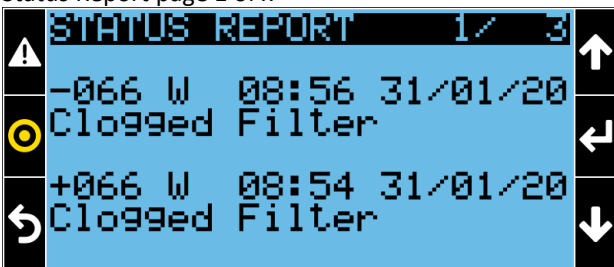

This menu contains the list of the last 200 events that occurred. Each entry includes:

- Event ID
- Event type (W = Warning; A = Alarm; M = Message)
- Event time
- Event description

Note: '+' indicates that the event has been generated. '-' indicates that the event has been reset.

2.8.3 Export Events



Export Events page 1 of 1



Enter the service or advanced credentials for accessing this menu (for service purposes only).

Memory type defines where to download the events log, either Internal Memory or USB.

Use the command **Events Log** to initiate the download of the events log.

Use the command **Clear Events Log** to clear the events log and the Status Report menu.

3 Events List

(*) This event shuts down the unit.

(**) This event might shut down the unit depending on the setting.

Event ID	Touch Display Description	Type	Reset
1	Retain Memory Error	Alarm	Auto
2	Too Much Retain Writing	Alarm	Auto
3	Heater High Temperature Lockout	Warning	Manual
4	High Return Temperature	Warning	Auto
5	High Supply Temperature (**)	Warning/Alarm	Auto
6	High Remote Temperature	Warning	Auto
7	Low Return Temperature	Warning	Auto
8	Low Supply Temperature	Warning	Auto
9	Low Remote Temperature	Warning	Auto
10	One (or more) Evaporator Fan in Alarm	Alarm	Auto
11	One (or more) Evaporator Fan Offline	Alarm	Auto
12	All Evaporator Fans Offline	Alarm	Auto
13	Loss of Air Flow (**)	Alarm	Manual
14	---	---	---
15	BMS Offline	Warning	Auto
16	Low Pressure Circuit 1 (**)	Alarm	Manual
17	Low Pressure Circuit 2 (**)	Alarm	Manual
18	High Pressure Circuit 1 (**)	Alarm	Manual
19	High Pressure Circuit 2 (**)	Alarm	Manual
20	Soft High Pressure Circuit 1 (**)	Warning/Alarm	Auto/Manual
21	Soft High Pressure Circuit 2 (**)	Warning/Alarm	Auto/Manual
22	Thermal Protection Compressor 1 Circuit 1 (**)	Alarm	Manual
23	Thermal Protection Compressor 2 Circuit 1 (**)	Alarm	Manual
24	Thermal Protection Compressor 1 Circuit 2 (**)	Alarm	Manual
25	Thermal Protection Compressor 2 Circuit 2 (**)	Alarm	Manual
26	Low Suction SuperHeat Circuit 1 (**)	Alarm	Manual
27	Low Suction SuperHeat Circuit 2 (**)	Alarm	Manual
28	High Suction SuperHeat Circuit 1 (**)	Alarm	Auto
29	High Suction SuperHeat Circuit 2 (**)	Alarm	Auto
30	Return Sensor Failure (Cumulative)	Alarm	Auto
31	Supply Sensor Failure (Cumulative)	Alarm	Auto
32	Remote Sensor Failure (Cumulative)	Alarm	Auto
33	Outdoor Sensor Failure	Alarm	Auto
34	Suction Pressure Sensor Circuit 1 Failure (**)	Alarm	Auto
35	Suction Pressure Sensor Circuit 2 Failure (**)	Alarm	Auto
36	Discharge Pressure Sensor Circuit 1 Failure (**)	Alarm	Auto
37	Discharge Pressure Sensor Circuit 2 Failure (**)	Alarm	Auto
38	Suction Temperature Sensor Circuit 1 Failure (**)	Alarm	Auto
39	Suction Temperature Sensor Circuit 2 Failure (**)	Alarm	Auto
40	Discharge Temperature Sensor Circuit 1 Failure (**)	Alarm	Auto
41	Discharge Temperature Sensor Circuit 2 Failure (**)	Alarm	Auto
42	Configurable Alarm (*)	Alarm	Auto
43	C-Input 1 (**)	Message/Warning/Alarm	Auto
44	C-Input 2 (**)	Message/Warning/Alarm	Auto

ENGLISH

45	C-Input 3 (**)	Message/Warning/Alarm	Auto
46	C-Input 4 (**)	Message/Warning/Alarm	Auto
47	Compressor Lockout (with PumpDown)	Message	Auto
48	Compressor Lockout	Message	Auto
49	Condenser 1 Failure	Warning	Auto
50	Condenser 2 Failure	Warning	Auto
51	Condensing Pump Alarm	Warning	Auto
52	Condensing Pump Alarm	Warning	Auto
53	Condensing Pump Alarm (*)	Alarm	Auto
54	Fire Alarm (*)	Alarm	Manual
55	Loss of Flow	Warning	Auto
56	Loss of Flow	Warning	Auto
57	Loss of Flow (*)	Alarm	Auto
58	Heater Alarm	Alarm	Manual
59	High CW1 Temperature (**)	Warning	Auto
60	High CW2 Temperature (**)	Warning	Auto
61	Humidifier Problem	Warning	Auto
62	Configurable Warning	Warning	Auto
63	Water Alarm (**)	Alarm	Auto
64	No Power	Warning	Auto
65	Smoke Alarm (**)	Warning/Alarm	Auto
66	Clogged Filter	Warning	Manual
67	Stop Due to High Temp (**)	Alarm	Auto
68	Out Of Working Range	Warning	Auto
69	High Remote Humidity	Warning	Auto
70	Low Return Humidity	Warning	Auto
71	Low Remote Humidity	Warning	Auto
72	High Return Humidity	Warning	Auto
73	---	---	---
74	---	---	---
75	Force FC	Message	Auto
76	---	---	---
77	---	---	---
78	---	---	---
79	---	---	---
80	---	---	---
81	UC Missing	Alarm	Auto
82	Conditioner/Fans Working Hours Exceeded	Warning	Auto
83	CW1 Valve Working Hours Exceeded	Warning	Auto
84	CW2 Valve Working Hours Exceeded	Warning	Auto
85	Comp1 Circ1 Working Hours Exceeded	Warning	Auto
86	Comp2 Circ1 Working Hours Exceeded	Warning	Auto
87	Comp1 Circ2 Working Hours Exceeded	Warning	Auto
88	Comp2 Circ2 Working Hours Exceeded	Warning	Auto
89	FC Working Hours Exceeded	Warning	Auto
90	AirEco Working Hours Exceeded	Warning	Auto
91	PRE1 Working Hours Exceeded	Warning	Auto
92	PRE2 Working Hours Exceeded	Warning	Auto
93	El. Heater1 Working Hours Exceeded	Warning	Auto

ENGLISH

94	El. Heater2 Working Hours Exceeded	Warning	Auto
95	Hot Water/Gas Working Hours Exceeded	Warning	Auto
96	Condenser 1 Working Hours Exceeded	Warning	Auto
97	Condenser 2 Working Hours Exceeded	Warning	Auto
98	Humidifier Working Hours Exceeded	Warning	Auto
99	Dehumidification Working Hours Exceeded	Warning	Auto
100	VSD Circuit 1 Out of Envelope (**)	Alarm	Auto
101	VSD Circuit 1 Generic Event (**)	Alarm	Auto
102	VSD Circuit 1 Offline (**)	Alarm	Auto
103	---	---	---
104	VSD Circuit 2 Out of Envelope (**)	Alarm	Auto
105	VSD Circuit 2 Generic Event (**)	Alarm	Auto
106	VSD Circuit 2 Offline (**)	Alarm	Auto
107	---	---	---
108	Network Failure	Warning	Auto
109	No Connection to Unit 1	Warning	Auto
110	---	---	---
111	One (or more) Condenser C1 Fan/Valve in Alarm	Warning	Auto
112	One (or more) Condenser C1 Fan/Valve Offline	Warning	Auto
113	All Condenser C1 Fans/Valves Offline	Warning	Auto
114	One (or more) Condenser C2 Fan/Valve in Alarm	Warning	Auto
115	One (or more) Condenser C2 Fan/Valve Offline	Warning	Auto
116	All Condenser C2 Fans/Valves Offline	Warning	Auto
117	---	---	---
118	HCB Offline	Warning	Auto
119	HCB Shut Down	Warning	Manual
120	Energy Meter Offline	Warning	Auto
121	Low Operating Pressure Circuit 1 (**)	Alarm	Auto
122	Low Operating Pressure Circuit 2 (**)	Alarm	Auto
123	Maximum Operating Pressure Circuit 2	Alarm	Auto
124	Maximum Operating Pressure Circuit 1	Alarm	Auto
125	Generic EEV Circuit 1 (**)	Alarm	Auto
126	Generic EEV Circuit 2 (**)	Alarm	Auto
127	EEV Driver Offline Circuit 1 (**)	Alarm	Auto
128	EEV Driver Offline Circuit 2 (**)	Alarm	Auto
129	All Condenser C1 Fans/Valves in Alarm	Warning	Auto
130	All Condenser C2 Fans/Valves in Alarm	Warning	Auto
131	High Discharge Temperature Circuit 1 (**)	Alarm	Auto/Manual
132	High Discharge Temperature Circuit 2 (**)	Alarm	Auto/Manual
133	Wrong Damper Position (*)	Alarm	Auto
134	Reduced Eco Air Flow	Warning	Auto
135	VSD Circuit 1 StartUp Failure (**)	Alarm	Manual
136	VSD Circuit 2 StartUp Failure (**)	Alarm	Manual
137	Loss of CW1 Flow (**)	Warning	Auto
138	Loss of CW2 Flow (**)	Warning	Auto
139	FC Off by Dehum	Message	Auto
140	FC Stopped for 1 Hour by Hum	Message	Auto
141	FC Stopped for 1 Hour by Dehum	Message	Auto
142	FC Stopped for 1 Hour by DT3	Message	Auto

ENGLISH

143	Dehum Stop by Low Limit 1	Message	Auto
144	Dehum Stop by Low Limit 2	Message	Auto
145	FC Lockout	Message	Auto
146	Second Set Point Active	Message	Auto
147	Heaters Lockout	Message	Auto
148	Humidifier and Heaters Lockout	Message	Auto
149	Humidifier Lockout	Message	Auto
150	Standby On	Message	Auto
151	Cool and Fan 100%	Message	Auto
152	Ultracap Active	Message	Auto
153	Power On	Message	Auto
154	Power Off	Message	Auto
155	Unit On	Message	Auto
156	---	---	---
157	Expansion Board 1 Offline (**)	Alarm	Auto
158	Expansion Board 2 Offline	Alarm	Auto
159	Heater High Temperature Probe Fail	Alarm	Auto
160	Optional Probe 1 Fail	Warning	Auto
161	Air Economizer Probe Fail	Warning	Auto
162	Glycol Temperature Probe Fail	Alarm	Auto
163	Optional Probe 2 Fail	Warning	Auto
164	Optional Probe 3 Fail	Warning	Auto
165	CW1 Inlet Probe Fail	Warning	Auto
166	CW1 Outlet Probe Fail	Warning	Auto
167	CW2 Inlet Probe Fail	Warning	Auto
168	CW2 Outlet Probe Fail	Warning	Auto
169	Local Static Pressure Sensor Fail (Cumulative)	Warning	Auto
170	System Static Pressure Sensor Fail	Warning	Auto
171	CW1 Water Flow Sensor Fail	Warning	Auto
172	CW2 Water Flow Sensor Fail	Warning	Auto
173	Return System Sensor Failure	Warning	Auto
174	Remote System Sensor Failure	Warning	Auto
175	HCB Disable	Warning	Manual
176	Mb CW Valve 1 Offline	Alarm	Auto
177	Mb CW Valve 2 Offline	Alarm	Auto
178	Mb CW Valve 3 Offline	Alarm	Auto
179	Mb CW Valve 4 Offline	Alarm	Auto
180	Supply Water High Conductivity	Warning	Manual
181	Air Eco Emergency Override	Message	Auto
182	Remote 1 Sensor Failure	Warning	Auto
183	Remote 2 Sensor Failure	Warning	Auto
184	Remote 3 Sensor Failure	Warning	Auto
185	Remote 4 Sensor Failure	Warning	Auto
186	Remote 5 Sensor Failure	Warning	Auto
187	Remote 6 Sensor Failure	Warning	Auto
188	Remote 7 Sensor Failure	Warning	Auto
189	Remote 8 Sensor Failure	Warning	Auto
190	Remote 9 Sensor Failure	Warning	Auto
191	Remote 10 Sensor Failure	Warning	Auto

ENGLISH

192	Condenser Refrigerant Sensor T1 Failure	Alarm	Auto
193	Pump1 Outlet Temp Sensor Failure	Alarm	Auto
194	Pump1 Inlet Press Sensor Failure	Alarm	Auto
195	Pump1 Outlet Press Sensor Failure	Alarm	Auto
196	Condenser Refrigerant Sensor T2 Failure	Alarm	Auto
197	Pump2 Outlet Temp Sensor Failure	Alarm	Auto
198	Pump2 Inlet Press Sensor Failure	Alarm	Auto
199	Pump2 Outlet Press Sensor Failure	Alarm	Auto
200	Pump1 Failure	Alarm	Auto
201	Pump2 Failure	Alarm	Auto
202	Condenser 1 Outdoor Temp Sensor Failure	Alarm	Auto
203	Condenser 2 Outdoor Temp Sensor Failure	Alarm	Auto
204	Expansion Board 3 Offline	Alarm	Auto
205	Expansion Board 4 Offline	Alarm	Auto
206	Unit Off by Display	Message	Auto
207	Unit Off by Remote Input	Message	Auto
208	Unit Off by 3 Pos Switch	Message	Auto
209	Unit Off by Monitoring	Message	Auto
210	Unit Off by Timer	Message	Auto
211	Unit Off by Alarm	Message	Auto
212	Unit Standby Mode	Message	Auto
213	Unit Manual Mode	Message	Auto
214	Very Low Outdoor Temperature	Warning	Auto
215	Very Low Outdoor Temperature	Alarm	Auto
216	Low SuperHeat Pump 1	Message	Auto
217	High SuperHeat Pump 1	Message	Auto
218	Low SubCool Pump 1	Alarm	Manual
219	Low Diff Press Pump 1	Alarm	Manual
220	High Diff Press Pump 1	Alarm	Manual
221	Low SuperHeat Pump 2	Message	Auto
222	High SuperHeat Pump 2	Message	Auto
223	Low SubCool Pump 2	Alarm	Manual
224	Low Diff Press Pump 2	Alarm	Manual
225	High Diff Press Pump 2	Alarm	Manual
226	Pump 1 Alarm	Alarm	Manual
227	Pump 2 Alarm	Alarm	Manual
228	Startup Failure Pump 1	Alarm	Manual
229	Startup Failure Pump 2	Alarm	Manual
230	Startup Lock Pump 1	Warning	Auto
231	Startup Lock Pump 2	Warning	Auto
232	Low Start Pressure Circuit 1 (**)	Alarm	Manual
233	Low Start Pressure Circuit 2 (**)	Alarm	Manual
234	Stop On Low Pressure Circuit 1 (**)	Message	Auto
235	Stop On Low Pressure Circuit 2 (**)	Message	Auto
236	Freeze Protection Circuit 1	Message	Auto
237	Freeze Protection Circuit 2	Message	Auto
238	Low Start Pressure Circuit 1	Message	Auto
239	Low Start Pressure Circuit 2	Message	Auto
240	Capacity Derating Circuit 1	Message	Auto

ENGLISH

241	Capacity Derating Circuit 2	Message	Auto
242	Static Pressure Out Of Range	Warning	Auto
243	EEV Circuit 1 Working Hours Exceeded	Warning	Auto
244	EEV Circuit 2 Working Hours Exceeded	Warning	Auto
245	EconoPhase Prop Lockout	Message	Auto
246	Surge Arrester Failure (**)	Alarm	Manual
247	Clogged Filter Th1	Warning	Manual
248	Clogged Filter Th2	Warning	Manual
249	Clogged Filter Error	Warning	Auto
250	ATS Error	Warning	Auto
251	Airflow Sensor Failure	Warning	Auto
252	Mb Condenser Valve 1 Offline	Alarm	Auto
253	Mb Condenser Valve 2 Offline	Alarm	Auto
254	Mb FC Valve 1 Offline	Alarm	Auto
255	Aux Sensor Disconnected	Warning	Auto
256	Loss of Cooling	Alarm	Manual
257	Mb CW Valve 1 Failure	Alarm	Auto
258	Mb CW Valve 2 Failure	Alarm	Auto
259	Mb CW Valve 3 Failure	Alarm	Auto
260	Mb CW Valve 4 Failure	Alarm	Auto
261	Battery Failure	Warning	Auto
262	Fanspeed Limited Due to Latent Content	Message	Auto
263	Electrical Panel Sensor Failure	Warning	Auto
264	Fan 100%	Message	Auto

The description of the events Configurable Alarm, Configurable Warning, C-Input 1, C-Input 2, C-Input 3, and C-Input 4 is customizable on the HMI.

Connect with Vertiv on Social Media



<https://www.facebook.com/vertiv/>



<https://www.instagram.com/vertiv/>



<https://www.linkedin.com/company/vertiv/>



<https://www.twitter.com/Vertiv/>

