



Liebert® CW

**Installer/User Guide**

305 kW, 375 kW, 415 kW Capacity, 50/60 Hz

The information contained in this document is subject to change without notice and may not be suitable for all applications. While every precaution has been taken to ensure the accuracy and completeness of this document, Vertiv assumes no responsibility and disclaims all liability for damages resulting from use of this information or for any errors or omissions.

Vertiv recommends installing a monitored fluid detection system that is wired to activate the automatic closure of field-installed coolant fluid supply and return shut off valves, where applicable, to reduce the amount of coolant fluid leakage and consequential equipment and building damage. Refer to local regulations and building codes relating to the application, installation, and operation of this product. The consulting engineer, installer, and/or end user is responsible for compliance with all applicable laws and regulations relating to the application, installation, and operation of this product.

The products covered by this instruction manual are manufactured and/or sold by Vertiv. This document is the property of Vertiv and contains confidential and proprietary information owned by Vertiv. Any copying, use, or disclosure of it without the written permission of Vertiv is strictly prohibited.

Names of companies and products are trademarks or registered trademarks of the respective companies. Any questions regarding usage of trademark names should be directed to the original manufacturer.

### **Technical Support Site**

If you encounter any installation or operational issues with your product, check the pertinent section of this manual to see if the issue can be resolved by following outlined procedures.

Visit <https://www.vertiv.com/en-us/support/> for additional assistance.

# TABLE OF CONTENTS

<b>1 Important Safety Instructions</b> .....	<b>1</b>
<b>2 Nomenclature and Components</b> .....	<b>5</b>
2.1 Liebert® CW Model Number Nomenclature .....	5
2.2 Component Location .....	8
<b>3 Pre-installation Preparation and Guidelines</b> .....	<b>9</b>
3.1 Planning Dimensions .....	9
3.2 Connections and System Setup .....	10
3.3 Operating Conditions .....	10
3.3.1 Cooling, Dehumidification and Humidification .....	10
3.3.2 Humidification Control .....	10
3.4 Shipping Dimensions and Unit Weights .....	10
<b>4 Equipment Inspection and Handling</b> .....	<b>11</b>
4.1 Packaging Material .....	11
4.2 Handling the Unit while Packaged .....	12
4.3 Unpacking the Unit .....	13
4.4 Removing the Unit from the Skid .....	14
4.5 Placing the Unit on a Floor Stand .....	17
<b>5 Electrical Connections</b> .....	<b>19</b>
<b>6 Piping Requirements</b> .....	<b>21</b>
6.1 Drain Fluid Connections .....	22
6.1.1 Field-installed, Gravity-fed Drain Line Requirements .....	22
6.1.2 Condensate-pump Drain Line Requirements .....	23
6.2 Chilled-water Loop Piping Guidelines .....	23
6.2.1 Leak Checking for Unit and Field-installed Piping .....	24
<b>7 Checklist for Completed Installation</b> .....	<b>25</b>
7.1 Moving and Placing Equipment .....	25
7.2 Electrical Installation Checks .....	25
7.3 Piping Installation Checks .....	25
7.4 Other Installation Checks .....	25
<b>8 Initial Start-up Checks and Commissioning Procedure for Warranty Inspection</b> .....	<b>27</b>
<b>9 Maintenance</b> .....	<b>29</b>
9.1 Filters .....	30
9.1.1 Replacing the Filters .....	31
9.2 Fan Maintenance .....	32
9.2.1 Fan Assembly Troubleshooting .....	32
9.2.2 Fan Impellers .....	33
9.2.3 Blower-motor Lubrication .....	33

9.2.4 Removing Fan Assembly ..... 33

9.3 Condensate-drain and Condensate-pump System Maintenance ..... 33

    9.3.1 Condensate Drain ..... 33

    9.3.2 Condensate Pump ..... 34

**10 Preventive Maintenance Checklist ..... 35**

**Appendices ..... 39**

Appendix A: Technical Support and Contacts ..... 39

Appendix B: Submittal Drawings ..... 41

# 1 Important Safety Instructions

## SAVE THESE INSTRUCTIONS

This manual contains important safety instructions that should be followed during the installation and maintenance of the Vertiv™ Liebert® CW. Read this manual thoroughly before attempting to install or operate this unit.

Only qualified personnel should move, install or service this equipment.

Adhere to all warnings, cautions, notices and installation, operating and safety instructions on the unit and in this manual. Follow all installation, operation and maintenance instructions and all applicable national and local building, electrical and plumbing codes.



**WARNING! Arc flash and electric shock hazard. Open all local and remote electric power-supply disconnect switches, verify with a voltmeter that power is Off and wear appropriate, OSHA-approved personal protective equipment (PPE) per NFPA 70E before working within the electric control enclosure. Failure to comply can cause serious injury or death. Customer must provide earth ground to unit, per NEC, CEC, and local codes, as applicable. Before proceeding with installation, read all instructions, verify that all the parts are included and check the nameplate to be sure the voltage matches available utility power. The Vertiv™ Liebert® iCOM™ controller does not isolate power from the unit, even in the “Unit Off” mode. Some internal components require and receive power even during the “Unit Off” mode of the Liebert® iCOM™ controller. The only way to ensure that there is NO voltage inside the unit is to install and open a remote disconnect switch. Refer to unit electrical schematic. Follow all local codes.**



**WARNING! Risk of electric shock. Can cause equipment damage, injury or death. Open all local and remote electric power supply disconnect switches and verify with a voltmeter that power is off before working within any electric connection enclosures. Service and maintenance work must be performed only by properly trained and qualified personnel and in accordance with applicable regulations and manufacturers’ specifications. Opening or removing the covers to any equipment may expose personnel to lethal voltages within the unit even when it is apparently not operating and the input wiring is disconnected from the electrical source.**



**WARNING! Risk of electric shock. Can cause serious injury or death. The Liebert® iCOM™ microprocessor does not isolate power from the unit, even in the "Unit Off" mode. Some internal components require and receive power even during the "unit off" mode of the Liebert® iCOM™ control. Open all local and remote electric power disconnect switches and verify with a voltmeter that power is Off before working on any component of the system.**



**WARNING! Risk of improper moving, lifting or handling of the unit. Can cause equipment damage, injury or death. Read all of the following instructions and verify that all lifting and moving equipment is rated for the weight of the unit before attempting to move, lift, remove packaging from or prepare the unit for installation. See **Table 3.2** on page 10 , for weights.**



**WARNING!** Risk of improper wiring, piping, moving, lifting and handling. Can cause equipment damage, serious injury or death. Installation and service of this equipment should be done only by qualified personnel who have been specially-trained in the installation of air-conditioning equipment and who are wearing appropriate, OSHA-approved PPE.



**WARNING!** Risk of improper wire sizing/rating and loose electrical connections. Can cause overheated wire and electrical connection terminals resulting in smoke, fire, equipment and building damage, injury or death. Use correctly sized copper wire only and verify that all electrical connections are tight before turning power On. Check all electrical connections periodically and tighten as necessary.



**WARNING!** Risk of top-heavy unit falling over. Improper handling can cause equipment damage, injury or death. Read all of the following instructions and verify that all lifting and moving equipment is rated for the weight of the unit before attempting to move, lift, remove packaging from or prepare the unit for installation.



**WARNING!** Risk of unsecured unit rolling off pallet. Can cause equipment damage, injury or death. The unit is on casters. Ensure that the unit/pallet is located on a flat surface before loosening the hardware securing the unit to its shipping pallet.



**WARNING!** Risk of hair, clothing, and jewelry entanglement with high speed rotating fan blades. Can cause equipment damage, serious injury or death. Keep hair, jewelry, and loose clothing secured and away from rotating fan blades during unit operation.



**WARNING!** Risk of contact with high-speed rotating fan blades. Can cause serious injury or death. Open all local and remote electric power-supply disconnect switches, verify with a voltmeter that power is off, and verify that all fan blades have stopped rotating before working in the unit cabinet or on the fan assembly. If control voltage is applied, the fan motor can restart without warning after a power failure. Do not operate the unit with any or all cabinet panels removed.



**WARNING!** Risk of contact with extremely hot and/or cold surfaces. Can cause injury. Verify that all components have reached a temperature that is safe for human contact or wear appropriate, OSHA-approved PPE before working within the electric connection enclosures or unit cabinet. Perform maintenance only when the system is de-energized and component temperatures have become safe for human contact.



**CAUTION:** Risk of contact with sharp edges, splinters, and exposed fasteners. Can cause injury. Only properly trained and qualified personnel wearing appropriate, OSHA-approved PPE should attempt to move, lift, remove packaging from or prepare the unit for installation.

**NOTICE**

Risk of improper power-supply connection. Can cause equipment damage and loss of warranty coverage.

Prior to connecting any equipment to a main or alternate power source (for example: back-up generator systems) for start-up, commissioning, testing, or normal operation, ensure that these sources are correctly adjusted to the nameplate voltage and frequency of all equipment to be connected. In general, power-source voltages should be stabilized and regulated to within  $\pm 10\%$  of the load nameplate nominal voltage. Also, ensure that no three-phase sources are single-phased at any time.

**NOTICE**

Risk of piping-system corrosion and freezing fluids. Can cause leaks resulting in equipment and very expensive building damage. Cooling coils and piping systems are at high risk of freezing and premature corrosion. Fluids in these systems must contain the proper antifreeze and inhibitors to prevent freezing and premature coil and piping corrosion. The water or water/glycol solution must be analyzed by a competent local water treatment specialist before start up to establish the inhibitor and antifreeze solution requirement and at regularly scheduled intervals throughout the life of the system to determine the pattern of inhibitor depletion.

The complexity of water/glycol solution condition problems and the variations of required treatment programs make it extremely important to obtain the advice of a competent and experienced water treatment specialist and follow a regularly scheduled coolant fluid system maintenance program.

Water chemistry varies greatly by location, as do the required additives, called inhibitors, that reduce the corrosive effect of the fluids on the piping systems and components. The chemistry of the water used must be considered, because water from some sources may contain corrosive elements that reduce the effectiveness of the inhibited formulation. Sediment deposits prevent the formation of a protective oxide layer on the inside of the coolant system components and piping. The water/coolant fluid must be treated and circulating through the system continuously to prevent the buildup of sediment deposits and or growth of sulfate reducing bacteria.

Proper inhibitor maintenance must be performed in order to prevent corrosion of the system. Consult glycol manufacturer for testing and maintenance of inhibitors.

Commercial ethylene glycol, when pure, is generally less corrosive to the common metals of construction than water itself. It will, however, assume the corrosivity of the water from which it is prepared and may become increasingly corrosive with use if not properly inhibited.

We recommend installing a monitored fluid-detection system that is wired to activate the automatic-closure of field-installed coolant-fluid supply and return shut-off valves to reduce the amount of coolant-fluid leakage and consequential equipment and building damage. The shut-off valves must be sized to close-off against the maximum coolant-fluid system pressure in case of a catastrophic fluid leak.

**NOTICE**

Risk of frozen pipes and corrosion from improper coolant mixture. Can cause water leaks resulting in equipment and building damage.

When the cooling unit or piping may be exposed to freezing temperatures, charge the system with the proper percentage of glycol and water for the coldest design ambient temperature. Automotive antifreeze is unacceptable and must NOT be used in any glycol fluid system. Use only HVAC glycol solution that meets the requirements of recommended industry practices. Do not use galvanized pipe.

**NOTICE**

Risk of no-flow condition. Can cause equipment damage.

Do not leave the water/coolant fluid-supply circuit in a no-flow condition. Idle fluid allows the collection of sediment that prevents the formation of a protective oxide layer on the inside of tubes. Keep unit switched On and water/coolant fluid-supply circuit system operating continuously.

**NOTICE**

Risk of clogged or leaking drain lines and leaking water-supply lines. Can cause equipment and building damage.

This unit requires a water drain connection. Drain lines must be inspected at start-up and periodically, and maintenance must be performed to ensure that drain water runs freely through the drain system and that lines are clear and free of obstructions and in good condition with no visible sign of damage or leaks. This unit may also require an external water supply to operate.

Improper installation, application and service practices can result in water leakage from the unit. Water leakage can result in catastrophic and expensive building and equipment damage and loss of critical data center equipment.

Do not locate unit directly above any equipment that could sustain water damage.

We recommend installing a monitored fluid-detection system to immediately discover and report coolant-fluid system and condensate drain-line leaks.

**NOTICE**

Risk of doorway/hallway interference. Can cause unit and/or structure damage. The unit may be too large to fit through a doorway or hallway while on the skid. Measure the unit and passageway dimensions, and refer to the installation plans prior to moving the unit to verify clearances.

**NOTICE**

Risk of damage from forklift. Can cause unit damage. Keep tines of the forklift level and at a height suitable to fit below the skid and/or unit to prevent exterior and/or underside damage.

**NOTICE**

Risk of improper storage. Can cause unit damage.

Keep the unit upright, indoors and protected from dampness, freezing temperatures, and contact damage.

## 2 Nomenclature and Components

This section describes the model number for Vertiv™ Liebert® CW units and components.

### 2.1 Liebert® CW Model Number Nomenclature

The following tables describe each digit of the configuration number. The 14-digit model number consists of the first 10 digits and last 4 digits of the configuration number.

**Table 2.1 Liebert® CW Model Number Example Digits 1 to 10**

1	2	3	4	5	6	7	8	9	10
C	W	4	1	5	D	1	3	A	1

**Table 2.2 Liebert® CW Configuration Number Detail Digits 11 to 25 Example**

11	12	13	14	15	16	17	18	19	20	21	22	23	24	25
1	2	0	8	1	0	L	0	0	0	P	0	0	0	0

**Table 2.3 Liebert® CW Configuration Number Detail Digits 26 to 36**

26	27	28	29	30	31	32	33	34	35	36
0	0	0	0	0	0	0	0	0	0	0

**Table 2.4 Liebert® CW Model Number Digits 37 to 40 Example**

37	38	39	40
#	#	#	A

**Table 2.5 Liebert® CW Model Number Digit Definitions**

Digit	Description
Digits 1 and 2 = Unit Family	CW = Liebert® CW floor-mounted, chilled-water unit
Digit 3, 4, 5 = Nominal Cooling Capacity, kW	305 = 305 kW 375 = 375 kW 415 = 415 kW
Digit 6 = Air Distribution	H = Horizontal discharge D = Bottom discharge
Digit 7 = Electric Panel Options	1 = Data hall or Bottom discharge, left electric panel 2 = Data hall or Bottom discharge, right electric panel 3 = Gallery, left electric panel 4 = Gallery, right electric panel

**Table 2.5 Liebert® CW Model Number Digit Definitions (continued)**

Digit	Description
Digit 8 = Fan Type	<p>3 = Direct-drive + VFD</p> <p>T = Direct-drive + VFD + THD</p>
Digit 9 = Voltage	<p>A = 460 V - 3 ph - 60 Hz</p> <p>B = 575 V - 3 ph - 60 Hz</p> <p>2 = 380 V - 3 ph - 60 Hz</p> <p>M = 380-415 V - 3 ph - 50 Hz</p>
Digit 10 = Valve Type	<p>1 = 2-way, fail-in-place, 400 PSI</p> <p>4 = 2-way, fail open, 400 PSI</p> <p>5 = 2-way, fail closed, 400 PSI</p>
Digit 11 = Agency	<p>1 = CSA</p>
Digit 12 = Display/Microprocessor Control	<p>2 = ICOM™ (high-definition)</p>
Digit 13 = Humidification	<p>0 = None</p>
Digit 14 = Air Filter	<p>8 = 4-in. MERV 8</p> <p>9 = 4-in. MERV 11</p>
Digit 15 = Coil	<p>1 = Standard coil</p>
Digit 16 = Seismic	<p>0 = None</p>
Digit 17 = High-voltage Options	<p>L = Locking disconnect</p> <p>S = Dual locking disconnect with reversing starter + Capacitive buffer</p>
Digit 18 = Option packages	<p>0 = None</p> <p>L = Low-voltage terminal package</p> <p>R = Remote-humidifier contact</p> <p>D = Low-voltage terminal package + Remote-humidifier contact</p>

**Table 2.5 Liebert® CW Model Number Digit Definitions (continued)**

Digit	Description
Digit 19 = Monitoring	<p>B = Base Comms &amp; Connectivity</p> <p>X = Base Comms + Ethernet +RS485 (SFA)</p> <p>R = Base Comms +SiteScan RS485 Expansion ( SFA)</p>
Digit 20 = Sensors	<p>O = None</p> <p>S = Smoke</p> <p>H = High temperature</p> <p>F = Smoke and High temperature</p>
Digit 21 = Packaging	<p>P = Domestic</p> <p>C = Export</p>
Digit 22, 23, 24, 25 = Placeholder	<p>O = Placeholder</p>
Digit 26 = Power Meter	<p>O = None</p> <p>P = Power Meter</p>
Digits 27 and 28 = Placeholder	<p>O = Placeholder</p>
Digit 29 = Condensate Pump	<p>O = None</p> <p>C = Condensate pump</p>
Digit 30 to 36	<p>O = Placeholder</p>
Digit 37 to 39 = Factory Configuration Number	
Digit 40 = Configuration Code	<p>A = No SFA</p> <p>S = SFA</p>

## 2.2 Component Location

The unit component locations are described in the submittal documents included in the [Submittal Drawings](#) on page 41.

The following table lists the relevant documents by number and title.

**Table 2.6 Component Location Drawings**

Document Number	Title
DPN004861	Component Location, Horizontal Discharge
DPN004899	Component Location, Bottom Discharge

## 3 Pre-installation Preparation and Guidelines

**NOTE:** Before installing unit, determine whether any building alterations are required to run piping, wiring, and duct work. Follow all unit dimensional drawings and refer to the submittal engineering dimensional drawings of individual units for proper clearances.

Refer to **Table 2.5** on page 5, and [Submittal Drawings](#) on page 41 to determine the type of system being installed and anticipate building alterations, piping and duct work needed.

The unit dimensions, pipe-connection locations, and piping schematics are described in the submittal documents included in the [Submittal Drawings](#) on page 41.

- Verify that the floor is level, solid and sufficient to support the unit. See **Table 3.2** on the next page, for unit weights.
- Confirm that the room is properly insulated and has a sealed vapor barrier.
- For proper humidity control, keep outside or fresh air to an absolute minimum (less than 5% of total air circulated in the room).
- Do not install a Vertiv™ Liebert® CW in an alcove or at the end of a long, narrow room.
- Install the units as close as possible to the largest heat load.
- Allow at least the minimum recommended clearances for maintenance and service. See the appropriate [Submittal Drawings](#) on page 41 for dimensions.
- We recommend installing an under-floor water detection system. Contact your Vertiv representative for information.

### 3.1 Planning Dimensions

The unit, floor stand, and plenum dimensions are described in the submittal documents included in the [Submittal Drawings](#) on page 41.

The following table lists the relevant documents by number and title.

**Table 3.1 Dimension Planning Drawings**

Document Number	Title
<b>Units</b>	
DPN004862	Cabinet and Plenum Dimensional Data, Horizontal Discharge
DPN004900	Cabinet and Plenum Dimensional Data, Bottom Discharge
DPN004870	Installation and Service Clearance Data, Horizontal and Bottom Discharge
DPN004869	Floor planning dimensional data for adjacent units
<b>Floor Stands</b>	
DPN004866	Floorstand Dimensional Data
<b>Airflow Schematic</b>	
DPN004865	Airflow Schematic, Horizontal Discharge
DPN004904	Airflow Schematic, Bottom Discharge

### 3.2 Connections and System Setup

- The unit requires a drain, which must comply with all applicable codes. See [Field-installed, Gravity-fed Drain Line Requirements](#) on page 22, for details.
- The unit requires supply and return water connections, which must comply with all applicable codes. See [Piping Requirements](#) on page 21.
- If seismic requirements apply, consult your Vertiv representative for information about a seismic-rated floor stand.

### 3.3 Operating Conditions

The Vertiv™ Liebert® CW must be operated in a conditioned space within the operating envelope that ASHRAE recommends for data centers. Operating the Liebert® CW outside of this envelope can decrease equipment reliability. Refer to ASHRAE’s publication, “Thermal Guidelines for Data Processing Environments.”

The recommended maximum for return-air temperature is 105°F (40°C) and maximum dew point is 59°F (15°C). The recommended minimum return-air temperature setpoint for the CW is 85°F (29.4°C).

#### 3.3.1 Cooling, Dehumidification and Humidification

Return air to the unit must be no cooler than the ASHRAE recommendation of 68°F (20°C) DB and 40% RH or minimum WB of 54°F (12.2°C) for proper unit operation. Operating below this can decrease equipment reliability.

#### 3.3.2 Humidification Control

The humidifier option is not available on the CW305, CW375, CW415. A remote humidifier contact is available for a stand-alone humidifier.

### 3.4 Shipping Dimensions and Unit Weights

**Table 3.2 Unit Domestic and Export Shipping Dimensions and Weights**

Model #	Domestic Packaging		Export Packaging		Dry Weight, lb (kg)
	Ship Weight, lb (kg)	Shipping Dimensions, in. (mm)	Ship Weight, lb (kg)	Shipping Dimensions, in. (mm)	
CW305 CW375 CW415	3890 (1764)	70 x 154 x 96.8 (1778 x 3911 x 2458)	4230 (1919)	70.5 x 154.5 x 99 (1790 x 3924 x 2514)	3300 (1497)
Fan section	3281 (1488)	90 x 128 x 54 (2286 x 3251 x 1372)	3676 (1667)	90.5 x 128.5 x 99 (2299 x 3264 x 2515)	2325 (1055)

## 4 Equipment Inspection and Handling



**WARNING!** Risk of top-heavy unit falling over. Improper handling can cause equipment damage, injury or death. Read all of the following instructions and verify that all lifting and moving equipment is rated for the weight of the unit before attempting to move, lift, remove packaging from or prepare the unit for installation.



**WARNING!** Risk of contact with sharp edges, splinters, and exposed fasteners. Can cause injury. Only properly trained and qualified personnel wearing appropriate, OSHA-approved PPE should attempt to move, lift, remove packaging from or prepare the unit for installation.

### NOTICE

Risk of passageway interference. Can cause unit and/or structure damage. The unit may be too large to fit through a passageway while on or off the skid. Measure the unit and passageway dimensions, and refer to the installation plans prior to moving the unit to verify clearances.

### NOTICE

Risk of damage from forklift. Can cause unit damage. Keep tines of the forklift level and at a height suitable to fit below the skid and/or unit to prevent exterior and/or underside damage.

### NOTICE

Risk of improper storage. Keep the unit upright, indoors and protected from dampness, freezing temperatures, and contact damage.

**NOTE:** Access panel screws have a maximum torque value of 40 in-lbs.

Upon arrival of the unit and before unpacking:

- Verify that the labeled equipment matches the bill of lading.
- Carefully inspect all items for visible or concealed damage.
- Report damage immediately to the carrier and file a damage claim with a copy sent to Vertiv or to your sales representative.

### Equipment Recommended for Handling the Unit:

- Forklift
- Slings
- Spreader bars
- Beam trolleys
- Chain hoists
- Gentries

### 4.1 Packaging Material



All material used to package this unit is recyclable. Please save for future use or dispose of the material appropriately.

## 4.2 Handling the Unit while Packaged

If possible, transport the unit with a forklift or pallet jack. If that is not possible, use a crane with slings and spreader bars that are rated for the weight of the unit.

When using a forklift or pallet jack:

- Ensure that the fork length is suitable for the unit length and, if adjustable, spread to the widest allowable distance that will fit under the skid.
- When moving the packaged unit, lift the unit from the end with the indicated labeling, and do not lift the unit any higher than 4 in. (102 mm). Ensure that the opposite end of the skid still touches the floor. The unit must be pulled by the forklift. All personnel except those moving the unit must be kept 12 ft (3.7 m) or more from the unit while it is being moved.
- If the unit must be lifted higher than 4 in. (102 mm), all personnel not directly involved in moving the unit must be 20 ft (5 m) or farther from the unit.
- Always refer to the location of the center-of-gravity indicators when lifting the unit, see **Figure 4.1** below .

**Figure 4.1 Center-of-gravity Indicator**



## 4.3 Unpacking the Unit

1. Refer to **Figure 4.2** below :
  - On units with domestic packaging, remove the exterior stretch wrap packaging from around the unit and any protective corner and side packaging planks.
  - On units with export packaging, remove the metal spring clips that secure the top and side panels of the crate. Then remove the exterior stretch wrap packaging from around the unit and any protective corner and side packaging planks.

**Figure 4.2 Unpacking the Unit**

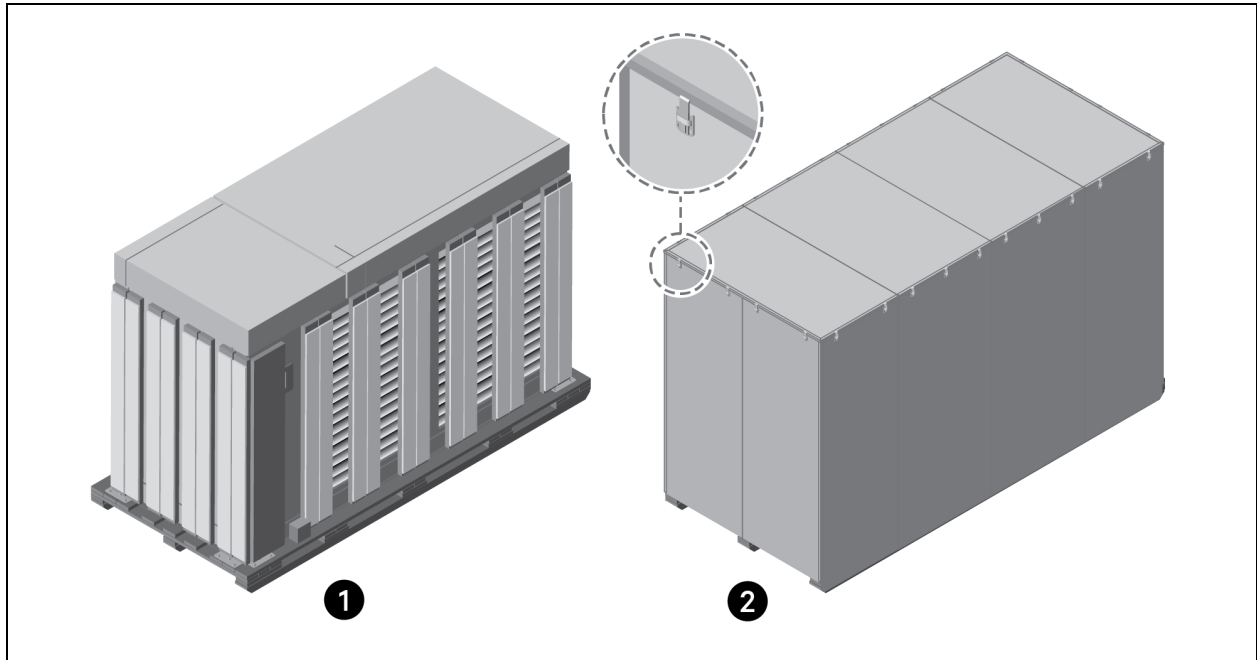

Item	Description
1	Domestic packaging
2	Export packaging

## 4.4 Removing the Unit from the Skid

**NOTE:** If you do not follow these steps, damage could occur to the panels and/or base of the unit.

1. Referring to **Figure 4.3** below, use a 9/16-in. socket driver to remove the lag screws (24 total) from the 4 corner brackets to detach the unit from the skid.

**Figure 4.3 Remove Corner Brackets**

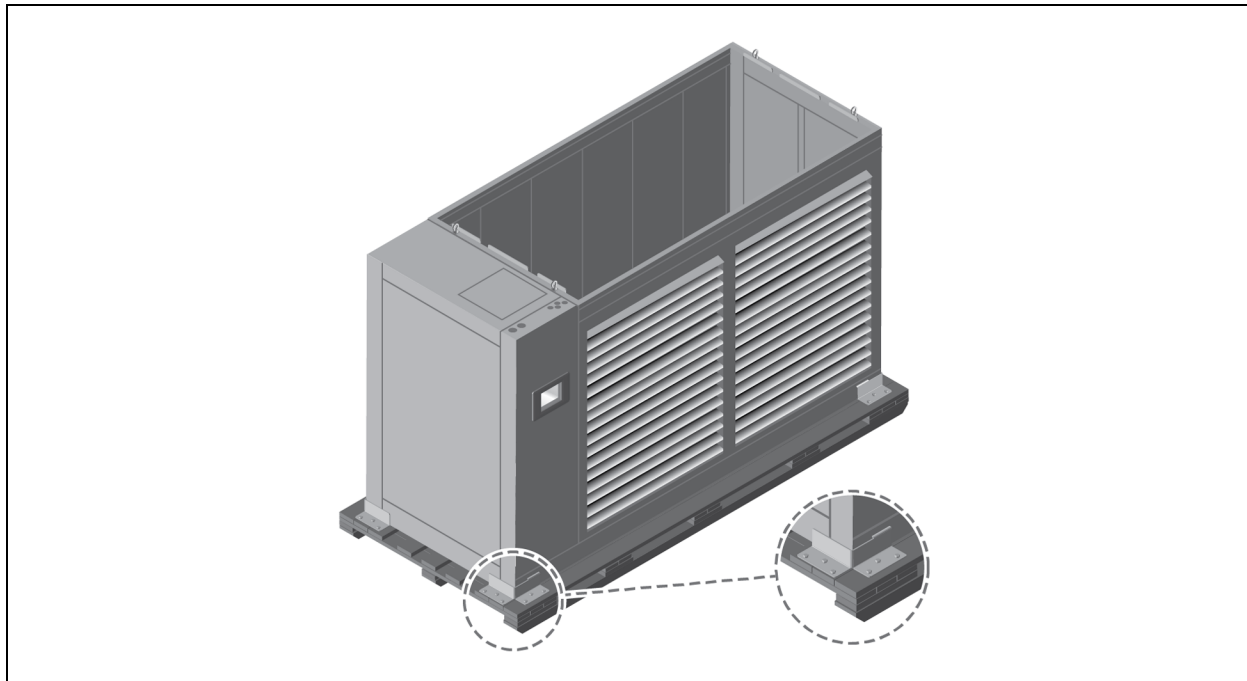

- Using the provided rigging-fastener kit and the instructions included in the kit, install the rigging hardware for lifting the unit from the skid. **Figure 4.4** below , shows an example of one of the eye nuts installed.

**Figure 4.4 Rigging-fastener Eye Nut Installed**

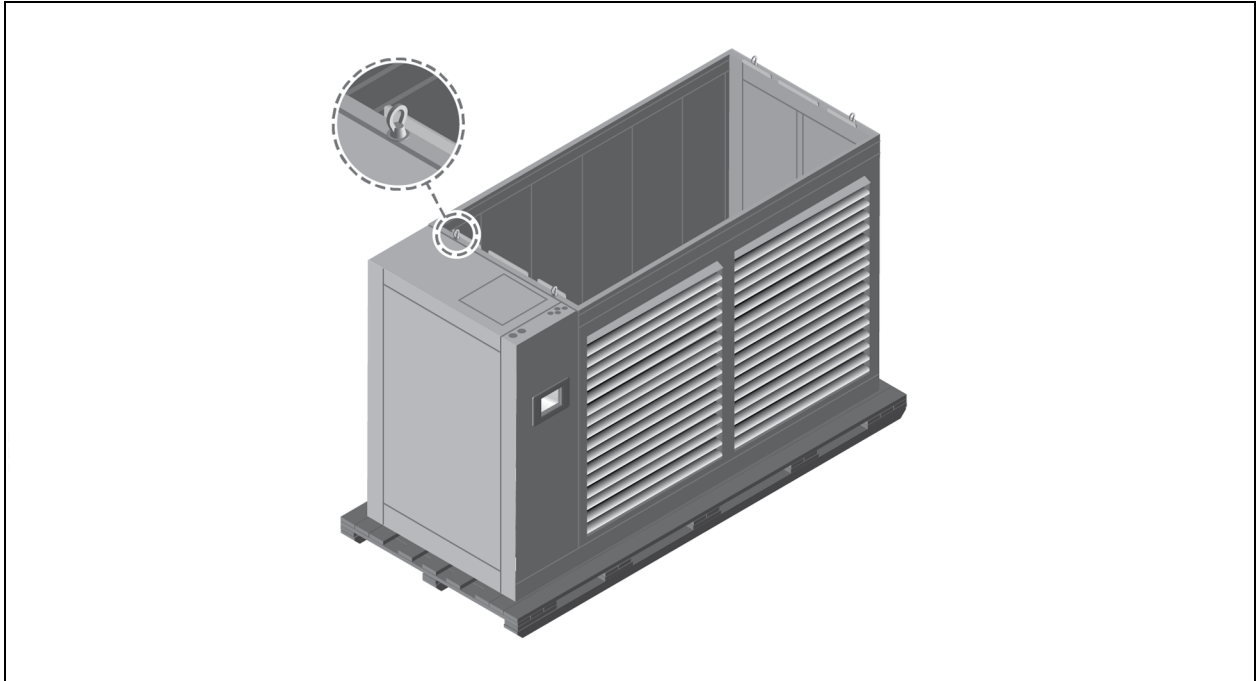

3. Attach the recommended rigging equipment to the eye-nuts installed in [Step 2](#).
4. Using the rigging equipment, lift the unit from the skid, and remove the skid from under the unit, see **Figure 4.5** below.

**Figure 4.5 Lifting Unit and Removing Skid**

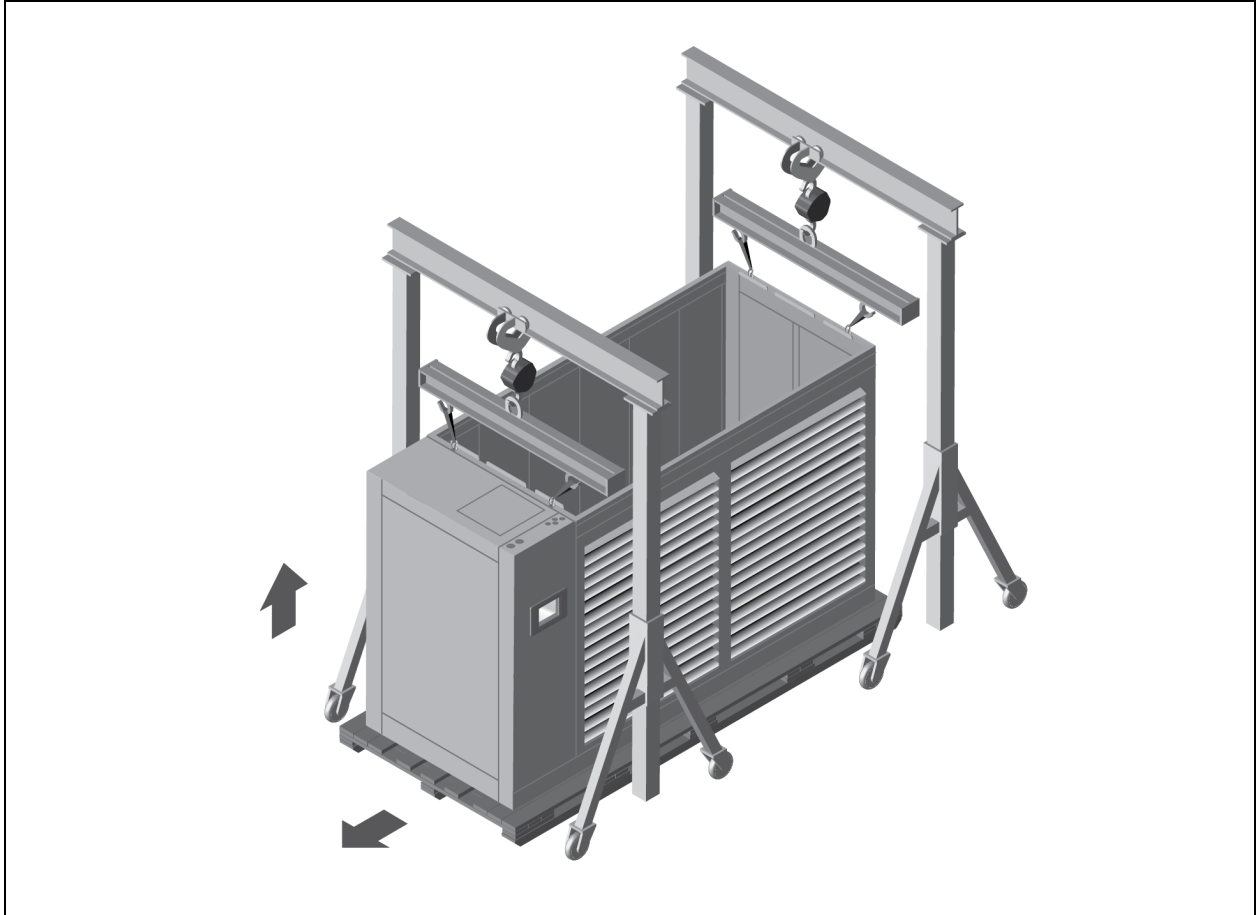

5. Use the rigging equipment to move the unit to the final installation location, see **Figure 4.6** below .

**Figure 4.6 Moving the Unit with Rigging**

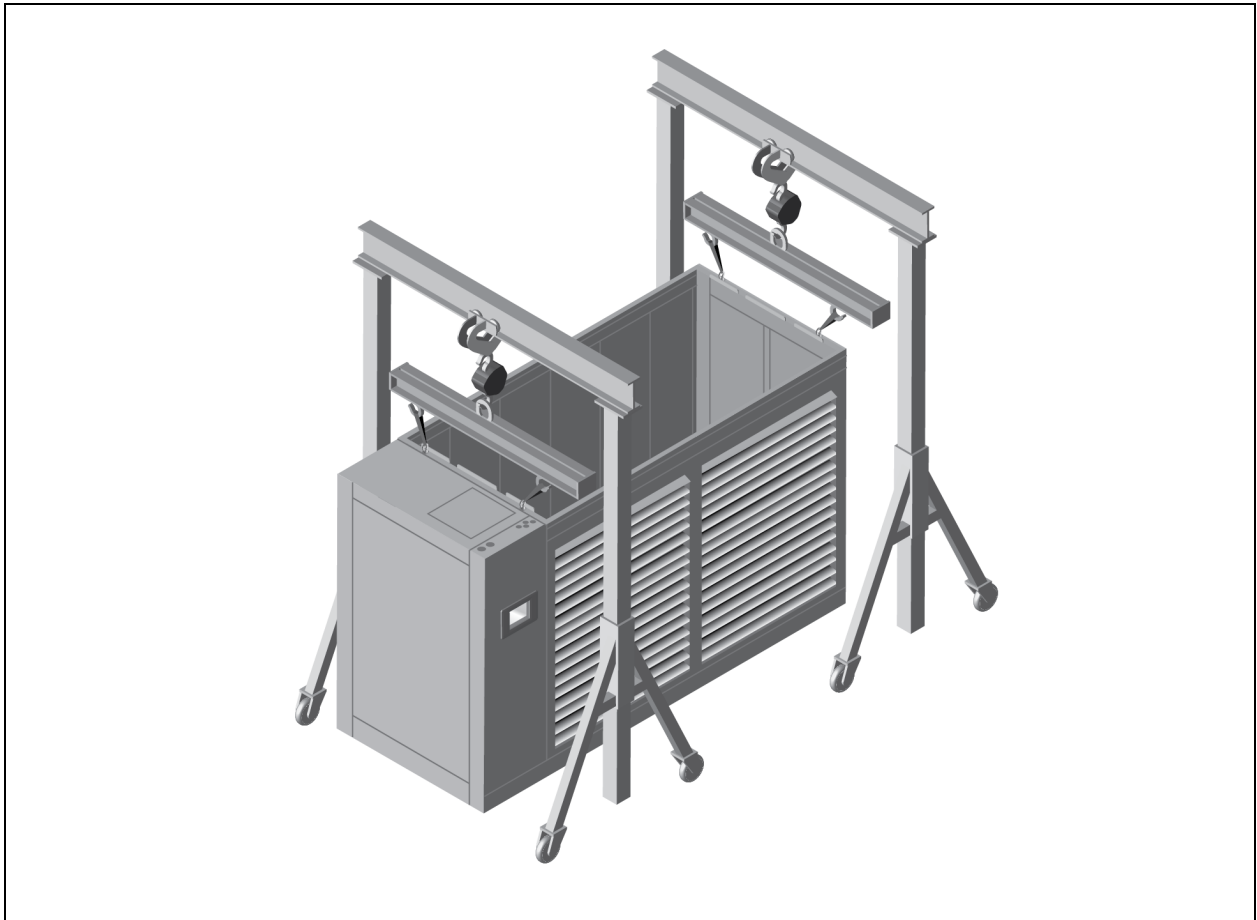

## 4.5 Placing the Unit on a Floor Stand



**CAUTION:** Risk of heavy unit falling into defective raised floor. Can cause injury and equipment damage. Prior to installation, all floor tiles immediately around floor stand are to be removed and inspected. Make sure tiles are not cracked, and ribs have not been cut. If free from defects, re-install. Replace with new tiles if defects are found.

Unit to be placed onto floor stand using process that will provide safest method based on site layout. Professional installers to be used when placing unit. Unit may require lift onto a floor stand if elevated flooring has not been installed. If flooring is installed, unit will be placed over floor opening containing floor stand.

This page intentionally left blank

## 5 Electrical Connections

Three-phase electrical service is required for all models. Electrical service must conform to national and local electrical codes. Refer to equipment nameplate regarding wire size and circuit protection requirements. Refer to electrical schematic when making connections. Refer to the appropriate submittal drawing, listed in **Table 5.1** on the next page, for electrical service entrances into unit.

A manual electrical disconnect switch should be installed in accordance with local codes and distribution system. Consult local codes for external disconnect requirements.



**WARNING! Arc flash and electric shock hazard. Open all local and remote electric power-supply disconnect switches, verify with a voltmeter that power is Off and wear appropriate, OSHA-approved personal protective equipment (PPE) per NFPA 70E before working within the electric control enclosure. Failure to comply can cause serious injury or death. Customer must provide earth ground to unit, per NEC, CEC, and local codes, as applicable. Before proceeding with installation, read all instructions, verify that all the parts are included and check the nameplate to be sure the voltage matches available utility power. The Vertiv™ Liebert® iCOM™ controller does not isolate power from the unit, even in the “Unit Off” mode. Some internal components require and receive power even during the “Unit Off” mode of the Liebert® iCOM™ controller. The only way to ensure that there is NO voltage inside the unit is to install and open a remote disconnect switch. Refer to unit electrical schematic. Follow all local codes.**



**WARNING! Risk of improper wiring, piping, moving, lifting and handling. Can cause equipment damage, serious injury or death. Installation and service of this equipment should be done only by qualified personnel who have been specially-trained in the installation of air-conditioning equipment and who are wearing appropriate, OSHA-approved PPE.**



**WARNING! Risk of improper wire sizing/rating and loose electrical connections. Can cause overheated wire and electrical connection terminals resulting in smoke, fire, equipment and building damage, injury or death. Use correctly sized copper wire only and verify that all electrical connections are tight before turning power On. Check all electrical connections periodically and tighten as necessary.**

### NOTICE

Risk of improper power-supply connection. Can cause equipment damage and loss of warranty coverage.

Prior to connecting any equipment to a main or alternate power source (for example: back-up generator systems) for start-up, commissioning, testing, or normal operation, ensure that these sources are correctly adjusted to the nameplate voltage and frequency of all equipment to be connected. In general, power-source voltages should be stabilized and regulated to within  $\pm 10\%$  of the load nameplate nominal voltage. Also, ensure that no three-phase sources are single-phased at any time.

See transformer label for primary tap connections. Installer will need to change transformer primary taps if applied unit voltage is other than pre-wired tap voltage.

The electrical and unit-to-unit connections are described in the submittal documents included in the [Submittal Drawings](#) on page 41.

The following table lists the relevant documents by number and title.

**Table 5.1 Electrical Field Connection Drawings**

Document Number	Title
DPN004864	Electrical Field Connections, CW305, 375, 415
DPN004863	Connection Locations, Data Hall with horizontal-discharge, Front-left facing electrical/piping compartment
DPN004901	Connection Locations, Bottom-discharge, Front-right facing electrical/piping compartment
DPN004923	Connection Locations, Data Hall with horizontal-discharge, Front-right facing electrical/piping compartment
DPN004903	Connection Locations, Bottom-discharge, Front-left facing electrical/piping compartment
DPN004924	Connection Locations, Gallery with horizontal-discharge, Front-right facing electrical/piping compartment
DPN004925	Connection Locations, Gallery with horizontal-discharge, Front-right facing electrical/piping compartment
<b>Unit-to-Unit Networking</b>	
DPN004351	Vertiv™ Liebert® iCOM™ Unit-to-unit Network Connections

## 6 Piping Requirements

All fluid connections to the unit, with the exception of the condensate drain, are sweat copper. Factory-installed piping brackets must not be removed. Field-installed piping must be installed in accordance with local codes and must be properly assembled, supported, isolated and insulated. Avoid piping runs through noise-sensitive areas, such as office walls and conference rooms.

Refer to specific text and detailed diagrams in this manual for other unit-specific piping requirements.

All piping below the elevated floor must be located so that it offers the least resistance to air flow. Careful planning of the piping layout under the raised floor is required to prevent the air flow from being blocked. When installing piping on the subfloor, we recommend that the pipes be mounted in a horizontal plane rather than stacked one above the other. Whenever possible, the pipes should be run parallel to the air flow.

The pipe connection locations, piping general arrangement and schematics are described in the submittal documents included in the [Submittal Drawings](#) on page 41.

The following tables list the relevant documents by number and title.

**Table 6.1 Piping General Arrangement Drawings**

Document Number	Title
DPN004952	Piping General Arrangement, CW305, 375, 415

**Table 6.2 Piping Connection Drawings**

Document Number	Title
DPN004863	Connection Locations, Data Hall with horizontal-discharge, Front-left facing electrical/piping compartment
DPN004901	Connection Locations, Bottom-discharge, Front-right facing electrical/piping compartment
DPN004923	Connection Locations, Data Hall with horizontal-discharge, Front-right facing electrical/piping compartment
DPN004903	Connection Locations, Bottom-discharge, Front-left facing electrical/piping compartment
DPN004924	Connection Locations, Gallery with horizontal-discharge, Front-right facing electrical/piping compartment
DPN004925	Connection Locations, Gallery with horizontal-discharge, Front-right facing electrical/piping compartment

## 6.1 Drain Fluid Connections

### NOTICE

Risk of water leakage. Can cause severe property damage and loss of critical data center equipment.

The Vertiv™ Liebert® CW requires a water drain connection. Improper installation, application and service practices can result in water leakage from the unit.

Do not locate the unit directly above any equipment that could sustain water damage.

We recommend installing monitored leak detection equipment for the water supply lines and the internal unit water lines.

The following pipe connections are required:

- A drain line from the unit
- Supply and return water lines

### 6.1.1 Field-installed, Gravity-fed Drain Line Requirements

#### NOTICE

Risk of water backing up in the drain line. Leaking and overflowing water can cause equipment and building damage.

Install an external, 5-1/2 in. trap in the drain line (if desired). The factory unit does not contain a trap.

Sagging condensate drain lines may inadvertently create an external trap.

Observe the following requirements when installing and routing the drain line:

- The drain line must be sized for 2 gpm (7.6 l/m) flow.
- The drain line must be located so it will not be exposed to freezing temperatures.
- The drain should be the full size of the drain connection.
- The drain line must slope continuously away from the unit. Pitch drain line toward drain a minimum of 1/8 in. (3 mm) per 1 ft (305 mm) of length.
- The drain line must be rigid enough that it does not sag between supports, which unintentionally creates traps.
- The drain line must comply with all applicable codes.
- We recommend installing monitored, under-floor leak-detection equipment.

## 6.1.2 Condensate-pump Drain Line Requirements

### NOTICE

Risk of water backing up in the drain line. Leaking and overflowing water can cause equipment and building damage.

Sagging condensate drain lines may inadvertently create an external trap.

Observe the following requirements when installing and routing the drain line:

- The drain line must be located so it will not be exposed to freezing temperatures.
- Size the piping based on the available condensate head.
- The drain line must be rigid enough that it does not sag between supports, which unintentionally creates traps.
- We recommend installing monitored, under-floor leak-detection equipment.

## 6.2 Chilled-water Loop Piping Guidelines



**WARNING! Risk of improper piping installation, leak checking, fluid chemistry and fluid maintenance can cause equipment damage and personal injury. Installation and service of this equipment should be done only by qualified personnel who have been specially-trained in the installation of air-conditioning equipment and who are wearing appropriate, OSHA-approved PPE.**

### NOTICE

Risk of frozen pipes and corrosion from improper coolant mixture. Can cause water leaks resulting in equipment and building damage.

When the cooling unit or piping may be exposed to freezing temperatures, charge the system with the proper percentage of glycol and water for the coldest design ambient temperature. Automotive antifreeze is unacceptable and must NOT be used in any glycol fluid system. Use only HVAC glycol solution that meets the requirements of recommended industry practices. Do not use galvanized pipe.

### NOTICE

Risk of piping-system corrosion and freezing fluids. Can cause leaks resulting in equipment and expensive building damage. Cooling coils and piping systems are at high risk of freezing and premature corrosion. Fluids in these systems must contain an inhibitor to prevent premature corrosion.

The system coolant fluid must be analyzed by a competent fluid-treatment specialist before start up to establish the inhibitor level and evaluated at regularly scheduled intervals throughout the life of the system to determine the pattern of inhibitor depletion. The fluid complexity and variations of required treatment programs make it extremely important to obtain the advice of a competent and experienced fluid-treatment specialist and follow a regularly scheduled coolant-fluid system-maintenance program.

Fluid chemistry varies greatly as do the required additives, called inhibitors, that reduce the corrosive effect of the fluids on the piping systems and components.

The chemistry of the coolant fluid used must be considered, because some sources may contain corrosive elements that reduce the effectiveness of the inhibited formulation. Sediment deposits prevent the formation of a protective oxide layer on the inside of the coolant system components and piping. The coolant fluid must be treated and circulating through the system continuously to prevent the buildup of deposits and/or growth of bacteria. Proper inhibitor maintenance must be performed to prevent corrosion of the system.

Consult fluid manufacturer for testing and maintenance of inhibitors.

Commercial-grade coolant fluid is generally less corrosive to the common metals of construction than water itself. It will, however, assume the corrosivity of the coolant fluid from which it is prepared and may become increasingly corrosive with use if not properly inhibited.

Vertiv recommends installing a monitored fluid-detection system that is wired to activate the automatic-closure of field-installed coolant-fluid supply and return shut-off valves to reduce the amount of coolant-fluid leakage and consequential equipment and building damage. The shut-off valves must be sized to close-off against the maximum coolant-fluid system pressure in case of a catastrophic fluid leak.

## NOTICE

Risk of no-flow condition. Can cause equipment damage.

Do not leave the water/coolant fluid-supply circuit in a no-flow condition. Idle fluid allows the collection of sediment that prevents the formation of a protective oxide layer on the inside of tubes. Keep unit switched On and water/coolant fluid-supply circuit system operating continuously.

Refer to the appropriate piping general-arrangement schematics for your system for the recommended, field-installed hardware such as shut-off valves. See **Table 6.1** on page 21 .

- Use copper piping with a brazing alloy with a minimum temperature of 1350°F (732°C), such as Sil-Fos. Avoid soft solders, such as 50/50 or 95/5.
- Follow local piping codes and safety codes.
- Qualified personnel must install and inspect system piping.
- The water/glycol-cooled system will operate in conjunction with a cooling tower, city water or drycooler.
- Contact a local water consultant regarding water quality, corrosion protection, and freeze-protection requirements.
- Install manual shut-off valves at the supply and return line to each unit to permit routine service and emergency isolation of the unit.
- Install a monitored, fluid-detection system that is wired to activate the automatic closure of field-installed coolant-fluid supply and return shut-off valves to reduce the amount of coolant fluid leakage and consequential equipment and building damage. The shut-off valves must be sized to close-off against the maximum coolant-fluid system pressure in case of a catastrophic fluid leak.

### 6.2.1 Leak Checking for Unit and Field-installed Piping

The fluid systems in the Vertiv™ Liebert® CW are factory-checked for leaks and may be shipped with holding charge. At installation, check all fluid circuits for leaks.

**NOTE: We recommend isolating the unit with field-installed shutoff valves during leak checking of field-installed piping. When the units are included in a leak test, use of fluid for pressure testing is recommended. When pressurized gas is used for leak testing the unit, the maximum recommended pressure is 30 psig (207 kPa) and tightness of the unit should be verified by pressure decay over time, (<2 psig/hour [13.8 kPa/hour]) or sensing a tracer gas with suitable instrumentation. Dry seals in fluid valves and pumps may not hold a high gas pressure.**

## 7 Checklist for Completed Installation

### 7.1 Moving and Placing Equipment

1. Unpack and check received material.
2. Proper clearance for service access has been maintained around the equipment.
3. Equipment is level and mounting fasteners are tight.

### 7.2 Electrical Installation Checks

1. Supply voltage and phase matches equipment nameplate.
2. Power wiring connections completed to the disconnect switch and unit.
3. Power line circuit breakers or fuses have proper ratings for equipment installed.
4. All internal and external high- and low-voltage wiring connections are tight.
5. Confirm that unit is properly grounded to an earth ground.
6. Control transformer setting matches incoming power.
7. Electrical service conforms to national and local codes.
8. Check blowers for proper rotation.

### 7.3 Piping Installation Checks

1. Piping completed to coolant loop.
2. Piping has been leak-checked.
3. Piping has been flushed to clear debris, pipe dope, and contaminants.
4. Piping is properly sized.
5. Check piping inside and outside of equipment for proper support and adequate spacing to prevent rub-through.
6. Ensure that factory clamps have been reinstalled.
7. Drain line connected, not obstructed, and pitched per local code.
8. Condensate drain connected.

### 7.4 Other Installation Checks

1. Ducting complete.
2. Filters installed.
3. Check fasteners that secure motors—some may have become loose during shipment.
4. All fans are free of debris.

This page intentionally left blank

## 8 Initial Start-up Checks and Commissioning Procedure for Warranty Inspection



**WARNING!** Arc flash and electric shock hazard. Open all local and remote electric power-supply disconnect switches, verify with a voltmeter that power is Off and wear appropriate, OSHA-approved personal protective equipment (PPE) per NFPA 70E before working within the electric control enclosure. Failure to comply can cause serious injury or death. Customer must provide earth ground to unit, per NEC, CEC, and local codes, as applicable. Before proceeding with installation, read all instructions, verify that all the parts are included and check the nameplate to be sure the voltage matches available utility power. The Vertiv™ Liebert® iCOM™ controller does not isolate power from the unit, even in the “Unit Off” mode. Some internal components require and receive power even during the “Unit Off” mode of the Liebert® iCOM™ controller. The only way to ensure that there is NO voltage inside the unit is to install and open a remote disconnect switch. Refer to unit electrical schematic. Follow all local codes.



**WARNING!** Risk of improper wiring, piping, moving, lifting and handling. Can cause equipment damage, serious injury or death. Installation and service of this equipment should be done only by qualified personnel who have been specially-trained in the installation of air-conditioning equipment and who are wearing appropriate, OSHA-approved PPE.



**CAUTION:** Risk of smoke generation. Can cause fire suppression and alarm system activation, resulting in injury during building evacuation and mobilization of emergency fire and rescue services. Start-up operation of optional electric reheat elements can create smoke or fumes that can activate the facility alarm and fire suppression system. Prepare and take appropriate steps to manage this possibility. Before beginning initial start-up checks, make certain that unit was installed according to the instructions in this manual. All exterior panels must be in place.

- Confirm that all items on [Checklist for Completed Installation](#) on page 25 have been done.
- Locate “Liebert® CW Warranty Inspection Check Sheet” in the unit’s electric panel.
- Complete “Liebert® CW Warranty Inspection Check Sheet” during start-up.
- Forward the completed “Liebert® CW Warranty Inspection Check Sheet” to your local sales office. **This information must be completed and forwarded to validate warranty.**
- Contact your local sales representative or technical support if you have any questions or problems during unit start-up and commissioning. Visit <https://www.Vertiv.com/en-us/support/> or call 1-800-543-2778 for contacts.

This page intentionally left blank

## 9 Maintenance



**WARNING!** Arc flash and electric shock hazard. Open all local and remote electric power-supply disconnect switches, verify with a voltmeter that power is Off and wear appropriate, OSHA-approved personal protective equipment (PPE) per NFPA 70E before working within the electric control enclosure. Failure to comply can cause serious injury or death. Customer must provide earth ground to unit, per NEC, CEC, and local codes, as applicable. Before proceeding with installation, read all instructions, verify that all the parts are included and check the nameplate to be sure the voltage matches available utility power. The Vertiv™ Liebert® iCOM™ controller does not isolate power from the unit, even in the “Unit Off” mode. Some internal components require and receive power even during the “Unit Off” mode of the Liebert® iCOM™ controller. The only way to ensure that there is NO voltage inside the unit is to install and open a remote disconnect switch. Refer to unit electrical schematic. Follow all local codes.



**WARNING!** Risk of electric shock. Can cause equipment damage, injury or death. Open all local and remote electric power supply disconnect switches and verify with a voltmeter that power is off before working within any electric connection enclosures. Service and maintenance work must be performed only by properly trained and qualified personnel and in accordance with applicable regulations and manufacturers’ specifications. Opening or removing the covers to any equipment may expose personnel to lethal voltages within the unit even when it is apparently not operating and the input wiring is disconnected from the electrical source.



**WARNING!** Risk of improper wiring, piping, moving, lifting and handling. Can cause equipment damage, serious injury or death. Installation and service of this equipment should be done only by qualified personnel who have been specially-trained in the installation of air-conditioning equipment and who are wearing appropriate, OSHA-approved PPE.



**WARNING!** Risk of electric shock. Can cause serious injury or death. The Liebert® iCOM™ microprocessor does not isolate power from the unit, even in the "Unit Off" mode. Some internal components require and receive power even during the "unit off" mode of the Liebert® iCOM™ control. Open all local and remote electric power disconnect switches and verify with a voltmeter that power is Off before working on any component of the system.

The Vertiv™ Liebert® CW is a single component in the facility heat-removal system. The system includes air distribution (raised floors, duct systems), outdoor heat rejection (pumps) and indoor cooling and humidity loads (equipment load, location, outside air infiltration). Proper application and maintenance of the entire system is critical to the life and reliability of the thermal-management units.

- Good maintenance practices are essential to minimizing operation costs and maximizing product life.
- Read and follow monthly and semi-annual maintenance schedules included in this manual. These MINIMUM maintenance intervals may need to be more frequent based on site-specific conditions.
- See the Liebert® iCOM™ User Manual, (SL-31075), available at [www.Vertiv.com](http://www.Vertiv.com), for instructions on using the controller to predict some service maintenance intervals.
- We recommend the use of trained and authorized service personnel, extended service contracts and factory-specified replacement parts. Contact your Vertiv sales representative.

## 9.1 Filters

### NOTICE

Risk of improper filter installation. Can cause filter collapse and airflow reduction.

To maximize the performance and reliability of the equipment, use only Vertiv filters. Contact your Vertiv representative to order replacement filters.

Verify that filters are installed and positioned so the air-flow direction marked on the filter is the same direction as unit air flow.

**Table 9.1 Filter Quantity and Type**

Unit Size	Filter Type	Filter Size, Width x Length x Depth	Quantity
CW305, CW375, CW415	MERV 8	28 x 22 x 4	15

## 9.1.1 Replacing the Filters



**WARNING!** Risk of contact with high-speed rotating fan blades. Can cause serious injury or death. Open all local and remote electric power-supply disconnect switches, verify with a voltmeter that power is off, and verify that all fan blades have stopped rotating before working in the unit cabinet or on the fan assembly. If control voltage is applied, the fan motor can restart without warning after a power failure. Do not operate the unit with any or all cabinet panels removed.

1. The filters are accessed through panels on the front side of the plenum at the front of the unit, see **Figure 9.1** below .

**Figure 9.1 Filter Access**

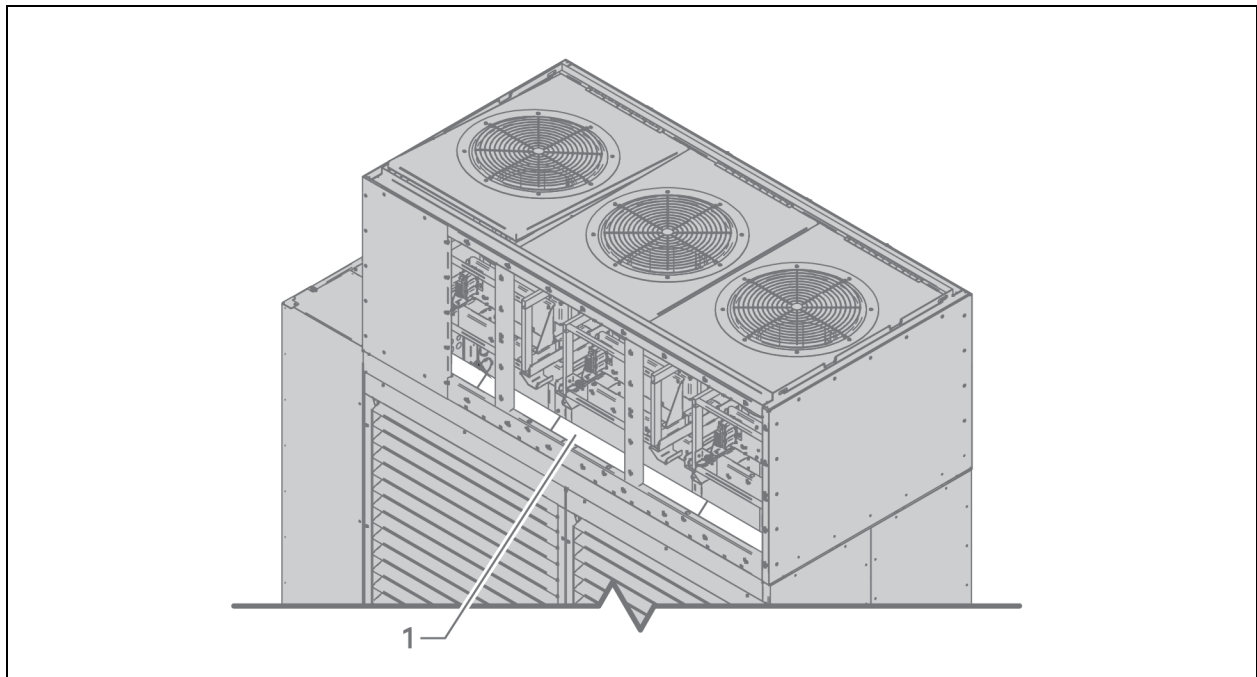

Item	Description
1	Front access on the front side of the fan plenum.

Figure 9.2 Removing and Installing the Air Filters

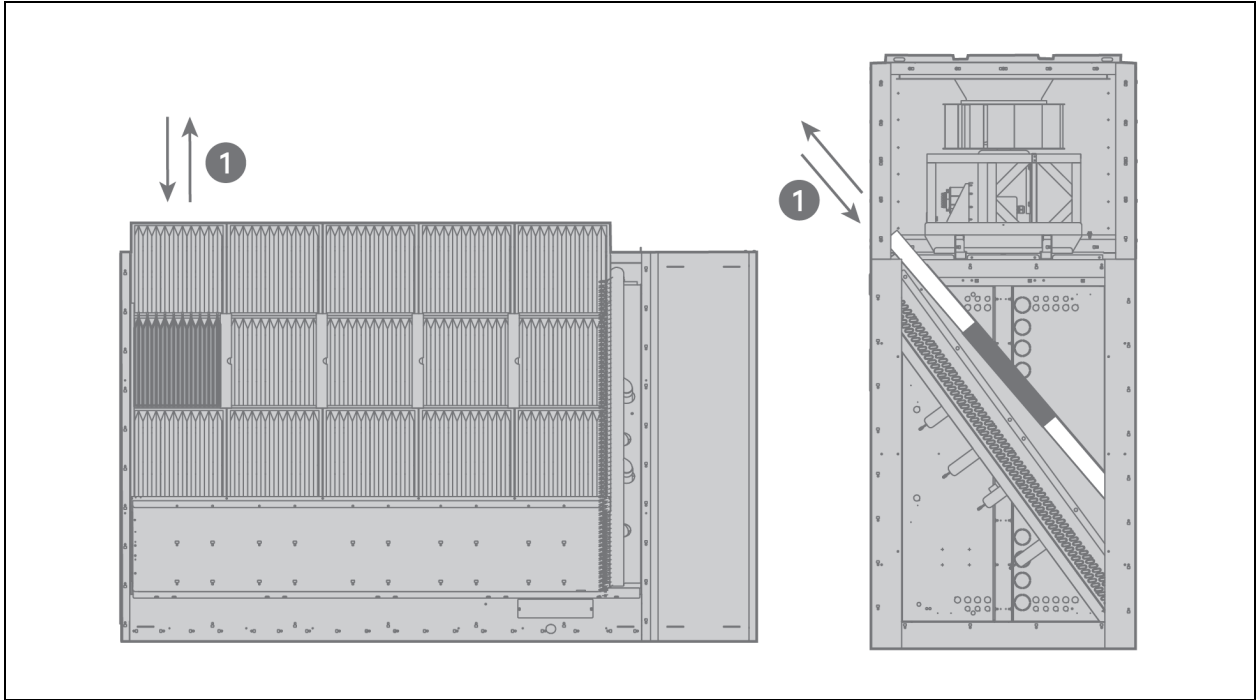

Item	Description
1	Remove and install filters up and down in the columns. There are 3 filters in each column.

## 9.2 Fan Maintenance

### 9.2.1 Fan Assembly Troubleshooting

Any safety hazards stemming from the device must be re-evaluated once it is installed in the end device.

Do not make any modifications, additions or conversions to the fan assembly without the approval of Vertiv.



**WARNING! Risk of electric shock. Can cause serious injury or death. Open all local and remote electric power-supply disconnect switches and verify with a voltmeter that power is off before opening the fan motor electric-connection enclosure. Use only fully-trained and qualified HVAC technicians to replace or perform maintenance on the EC fans.**



**WARNING! Risk of contact with high-speed rotating fan blades. Can cause serious injury or death. Open all local and remote electric power-supply disconnect switches, verify with a voltmeter that power is off, and verify that all fan blades have stopped rotating before working in the unit cabinet or on the fan assembly. If control voltage is applied, the fan motor can restart without warning after a power failure. Do not operate the unit with any or all cabinet panels removed.**



**CAUTION:** Risk of exposure to harmful noise levels. Can cause hearing injury or loss. Depending on the installation and operating conditions, a sound pressure level greater than 70 dB(A) may arise. Take appropriate technical safety measures. Operating personnel must wear appropriate, OSHA-approved PPE and observe all appropriate hearing-protection safety requirements.



**CAUTION:** Risk of contact with hot surfaces. Can cause injury. The fan motor, and some electrical components are extremely hot during unit operation. Allow sufficient time for them to cool to a touch-safe temperature before working within the unit cabinet. Use extreme caution and wear appropriate, OSHA-approved PPE when working on or near hot components.

## NOTICE

Risk of improper power-supply connection. Can cause equipment damage and loss of warranty coverage.

Prior to connecting any equipment to a main or alternate power source (for example: back-up generator systems) for start-up, commissioning, testing, or normal operation, ensure that these sources are correctly adjusted to the nameplate voltage and frequency of all equipment to be connected. In general, power-source voltages should be stabilized and regulated to within  $\pm 10\%$  of the load nameplate nominal voltage. Also, ensure that no three-phase sources are single-phased at any time.

**NOTE:** Do not assume that the fan blades will not start to spin. If the motor is in a fault condition, it will safely shut down. Once the fault condition is cleared, there are certain conditions in which the motor will automatically resume operation.

## 9.2.2 Fan Impellers

Fan impellers should be periodically inspected and any debris removed. Check to ensure that the impellers can rotate freely.

Consult the factory for fan-assembly maintenance and removal instructions. Do not attempt to service or remove the fans without first contacting Vertiv support at 1-800-543-2778.

## 9.2.3 Blower-motor Lubrication

The motor is initially lubricated at the factory.

- Contact the motor manufacturer for the lubrication interval for motor bearings.
- Contact the motor manufacturer to determine the type of grease to use for lubrication.

## 9.2.4 Removing Fan Assembly

Do not attempt to remove the fan assemblies without first contacting Vertiv Technical Support at 1-800-543-2778.

# 9.3 Condensate-drain and Condensate-pump System Maintenance

## 9.3.1 Condensate Drain

Check for and clear obstructions in tubing during routine maintenance.

### 9.3.2 Condensate Pump



**WARNING! Risk of electric shock. Can cause injury or death. Open all local and remote electric power-supply disconnect switches and verify that power is Off with a voltmeter before working within the condensate pump electrical connection enclosure. The Vertiv™ Liebert® iCOM™ does not isolate power from the unit, even in the “Unit Off” mode. Some internal components require and receive power even during the “Unit Off” mode of the Liebert® iCOM™.**

#### To maintain the condensate pump:

1. Disconnect power to the unit using the disconnect switch.
2. Check for and clear obstructions in gravity lines leading to the condensate pump.
3. Remove the sump, clean with a stiff nylon brush and flush with water.
4. Inspect and clear clogs in the discharge check valve and float mechanism.
5. Reassemble and check for leaks.

# 10 Preventive Maintenance Checklist

Source: DPN002952, Rev. 4

Inspection Date	Job Name		
Indoor Unit Model #	Indoor Unit Serial Number #		
Room Temperature/Humidity	°	%	Ambient Temperature °

Not all units will have all components. To determine your unit's configuration, compare the [Indoor Unit Model #](#) above and the information in the Components and Nomenclature section.

Good maintenance practices are essential to minimizing operation cost and maximizing product life. Read and follow all applicable maintenance checks listed below. At a minimum, these checks should be performed semi-annually. However, maintenance intervals may need to be more frequent based on site-specific conditions. Review the unit user manual for further information on unit operation. We recommend the use of trained and authorized service personnel, extended service contracts, and factory-certified replacement parts. Contact your local sales representative for more details.

## **Check all that apply:**

### **Evaporator/Filters**

1. Check/Replace filters.
2. Grille area unrestricted.
3. Wipe section clean.
4. Coil clean.
5. Clean condensate pan.
6. Clean trap in condensate drain.
7. Check/Test filter-clog switch operation (if equipped).

### **Blower Section**

1. Blower wheels free of debris.
2. Check/Lube bearings.
3. Check/Lube motor (if supplied with grease ports). Check motor manufacturer's web site for procedure, amount and type of grease required.
4. Check motor mount.
5. Check/Test air sail switch.
6. Motor amp draw.
  - Compare to nameplate amps.

#1	L1	L2	L3
#2	L1	L2	L3
#3	L1	L2	L3

### **Condensate Pump (if equipped)**

1. Check for debris in sump.
2. Check operation of float(s) (free movement).
3. Check/Clean discharge check valve.

### **Electrical Panel**

1. Check fuses.
2. Check contactors for pitting (replace if pitted).
3. Check/Re-torque wire connections.



This page intentionally left blank

# Appendices

## Appendix A: Technical Support and Contacts

### A.1 Technical Support/Service in the United States

Vertiv Group Corporation

24x7 dispatch of technicians for all products.

1-800-543-2378

Liebert® Thermal Management Products

1-800-543-2778

Liebert® Channel Products

1-800-222-5877

Liebert® AC and DC Power Products

1-800-543-2378

### A.2 Locations

#### United States

Vertiv Headquarters

505 N. Cleveland Ave.

Westerville, OH, 43082, USA

#### Europe

Via Leonardo Da Vinci 8 Zona Industriale Tognana

35028 Piove Di Sacco (PD) Italy

#### Asia

7/F, Dah Sing Financial Centre

3108 Gloucester Road

Wanchai, Hong Kong

This page intentionally left blank

## Appendix B: Submittal Drawings

Table 12.1 below, groups the drawings by topic/application.

**Table 12.1 Submittal Drawings Contents**

Document Number	Title
<b>Component Location</b>	
DPN004861	Component Location, Horizontal Discharge
DPN004899	Component Location, Bottom Discharge
<b>Planning Dimensions - Units</b>	
DPN004862	Cabinet and Plenum Dimensional Data, Horizontal Discharge
DPN004900	Cabinet and Plenum Dimensional Data, Bottom Discharge
DPN004870	Installation and Service Clearance Data, Horizontal and Bottom Discharge
DPN004868	Disassembly Dimensional Data
DPN004869	Floor planning dimensional data for adjacent units
<b>Planning Dimensions - Floor Stands</b>	
DPN004866	Floorstand Dimensional Data
<b>Airflow Schematic</b>	
DPN004865	Airflow Schematic, Horizontal Discharge
DPN004904	Airflow Schematic, Bottom Discharge
<b>Piping General Arrangement</b>	
DPN004952	Piping General Arrangement, CW305, 375, 415
<b>Electrical &amp; Piping Connections</b>	
DPN004863	Connection Locations, Data Hall with horizontal-discharge, Front-left facing electrical/piping compartment
DPN004901	Connection Locations, Bottom-discharge, Front-right facing electrical/piping compartment
DPN004923	Connection Locations, Data Hall with horizontal-discharge, Front-right facing electrical/piping compartment
DPN004903	Connection Locations, Bottom-discharge, Front-left facing electrical/piping compartment
DPN004924	Connection Locations, Gallery with horizontal-discharge, Front-right facing electrical/piping compartment
DPN004925	Connection Locations, Gallery with horizontal-discharge, Front-right facing electrical/piping compartment
DPN004867	Gravity Condensate Piping
10017435	Condensate Pump Installation
<b>Detailed Electrical Connections</b>	
DPN004864	Electrical Field Connections, CW305, 375, 415
DPN005196	Automatic Transfer Switch
DPN005121	THD Transformer

**Table 12.1 Submittal Drawings Contents (continued)**

Document Number	Title
Unit-to-Unit Networking	
DPN004351	Vertiv™ Liebert® iCOM™ Unit-to-unit Network Connections
Seismic Applications	
10019855	Liebert® CW Large Seismic, 305-415kW

**COMPONENT LOCATION DIAGRAM  
CW305, 375, 415 W/ HORIZONTAL DISCHARGE**

1. Blower/Motor (Typical 3)
2. Line Reactor Transformers (Typical 3)
3. Evaporator Coil
4. Air Filters
5. Condensate Pump (optional)
6. Electric Panel
7. THD Mitigation Device (optional)
8. VFD Assemblies (Typical 3)
9. 575V Transformer (if applicable)

Notes:

1. Electrical Compartment (item #6) shown on left side of unit.  
Unit may be ordered with Electrical Compartment on either side,  
or with Electrical Compartment facing into Gallery space.
2. Grills and panels removed for clarity.

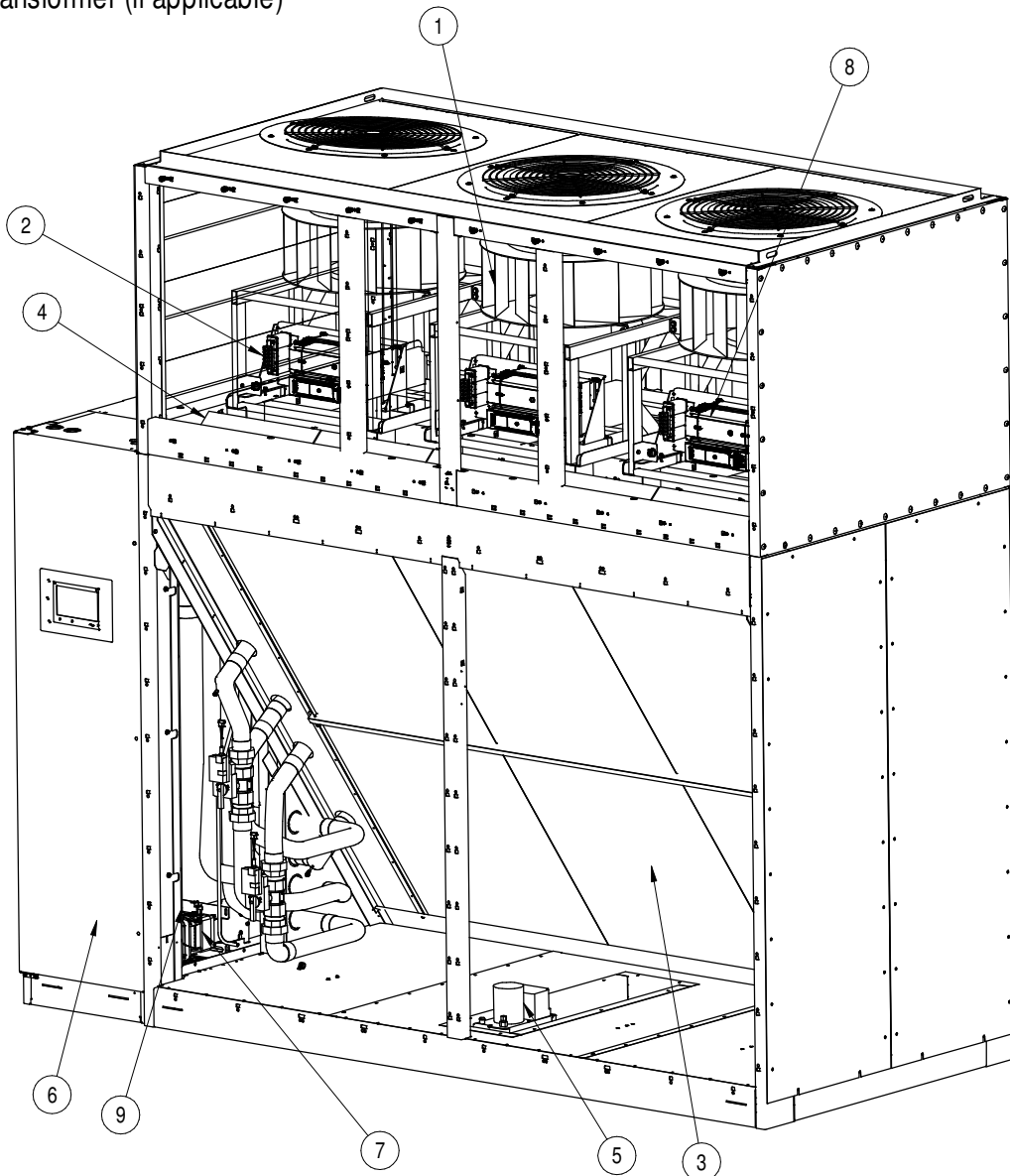

**COMPONENT LOCATION DIAGRAM  
CW305, 375, 415 W/ BOTTOM DISCHARGE**

1. Blower/Motor (Typical 3)
2. Line Reactor Transformers (Typical 3)
3. Evaporator Coil
4. Air Filters
5. Condensate Pump (optional, shipped loose)
6. Electric Panel
7. THD Mitigation Device (optional)
8. VFD Assemblies (Typical 3)
9. 575V Transformer (if applicable)

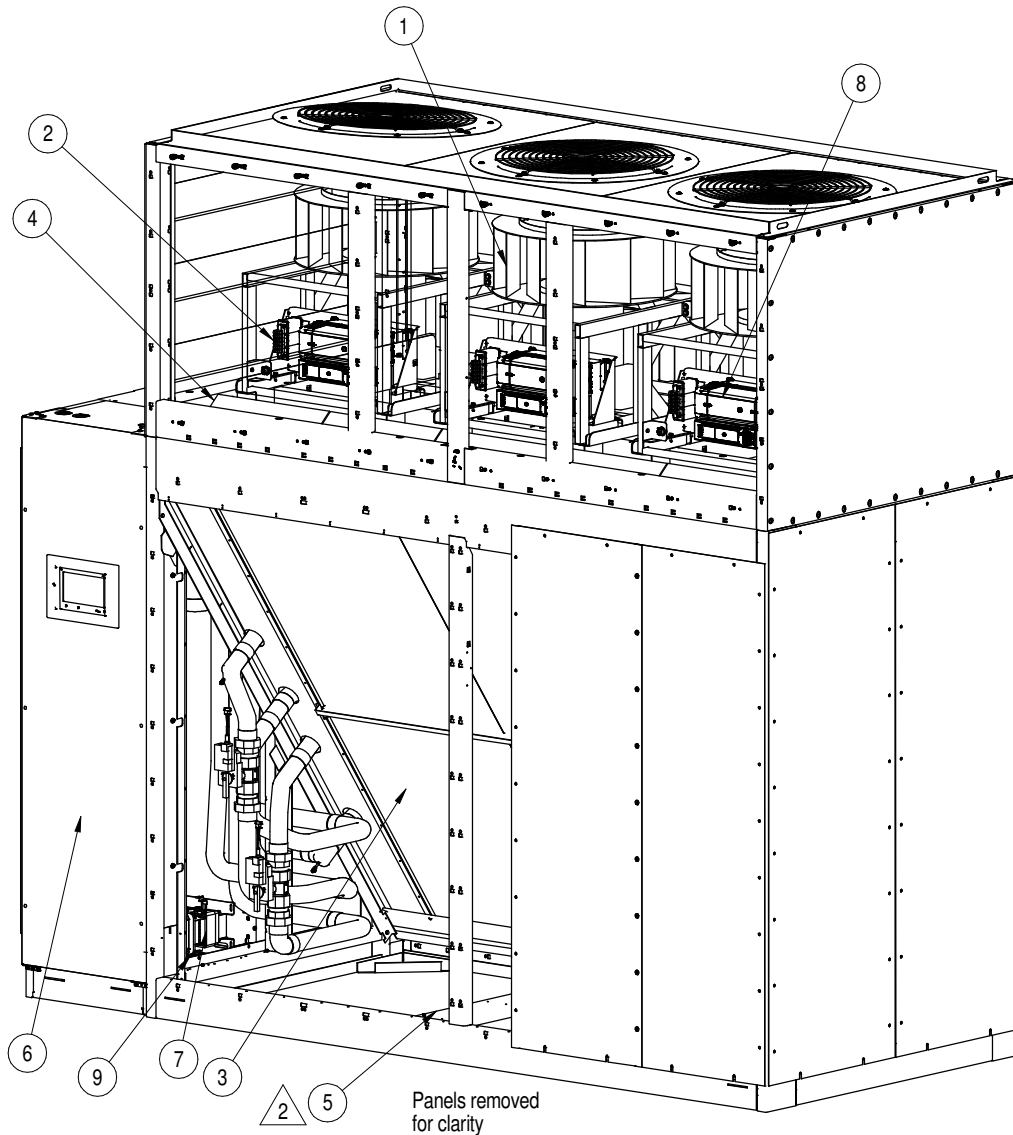

**Notes:**

1. Electrical Compartment (item #6) shown on left side of unit. Unit may be ordered with Electrical Compartment on either side, or with Electrical Compartment facing into Gallery space.

2. Condensate Pump (if ordered) to be shipped loose and attached to this frame member for shipping. Customer to locate and install.

**CABINET DIMENSIONAL DATA**  
**CW305, 375, 415 W/ HORIZONTAL DISCHARGE**

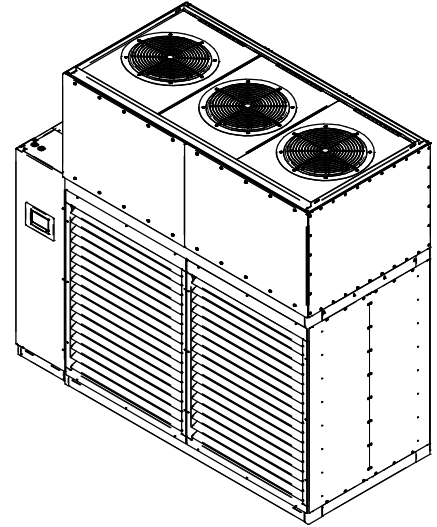
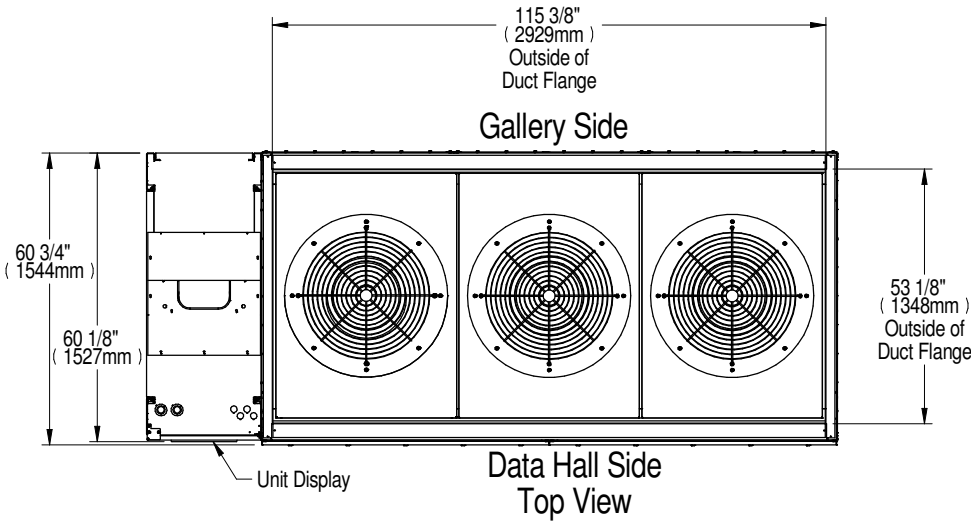

For Unit Disassembly Data  
Refer to DPN004868

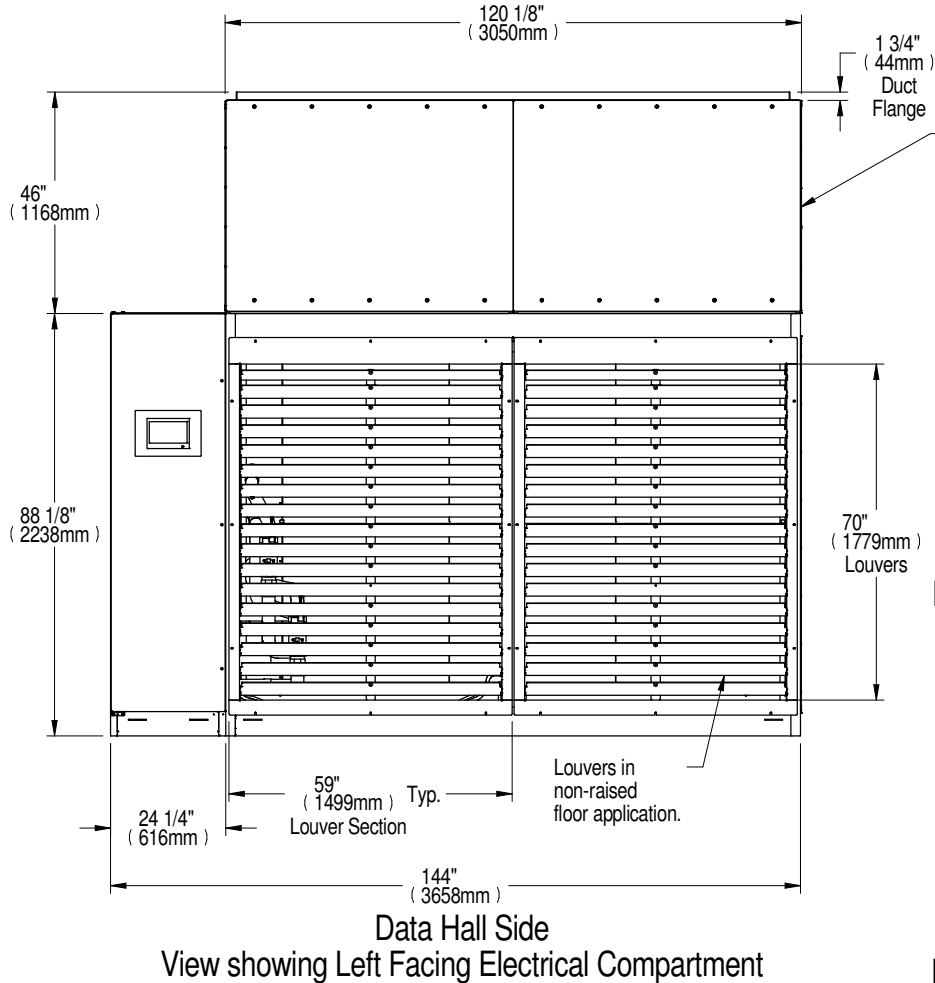

Fan Plenum is shipped separately and field installed.

**Data Hall Unit configuration**

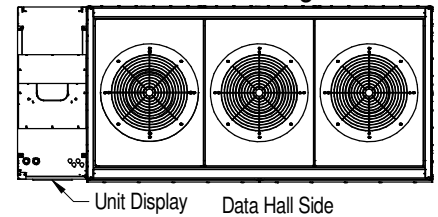

Left Facing Electrical Compartment  
(may be ordered with  
Electrical Compartment facing Gallery Side)

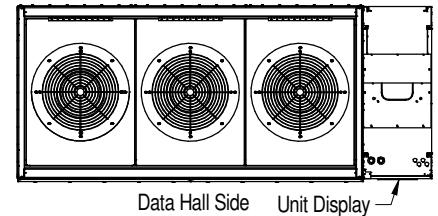

Right Facing Electrical Compartment  
(may be ordered with  
Electrical Compartment facing Gallery Side)

**CABINET DIMENSIONAL DATA**  
**CW305, 375, 415 W/ BOTTOM DISCHARGE**

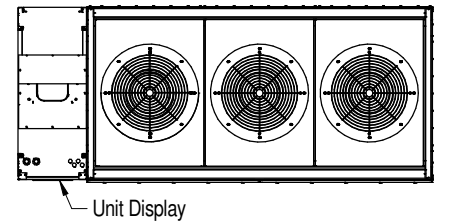
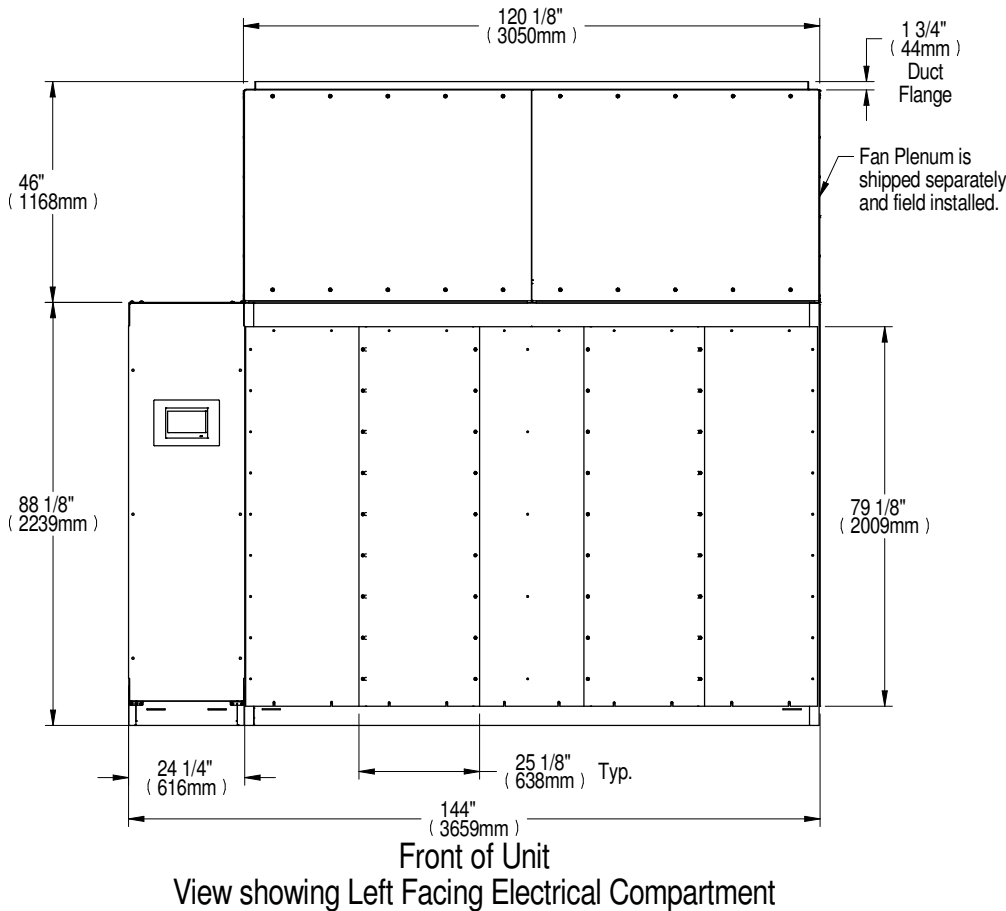
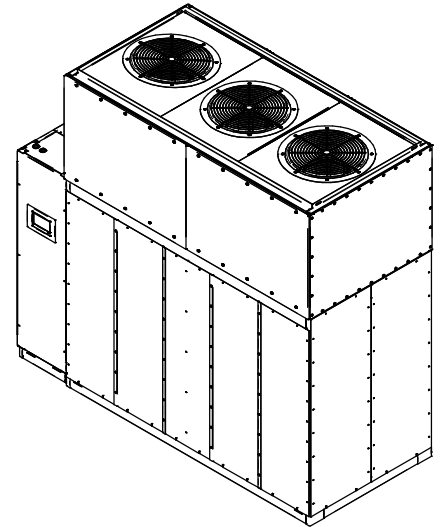
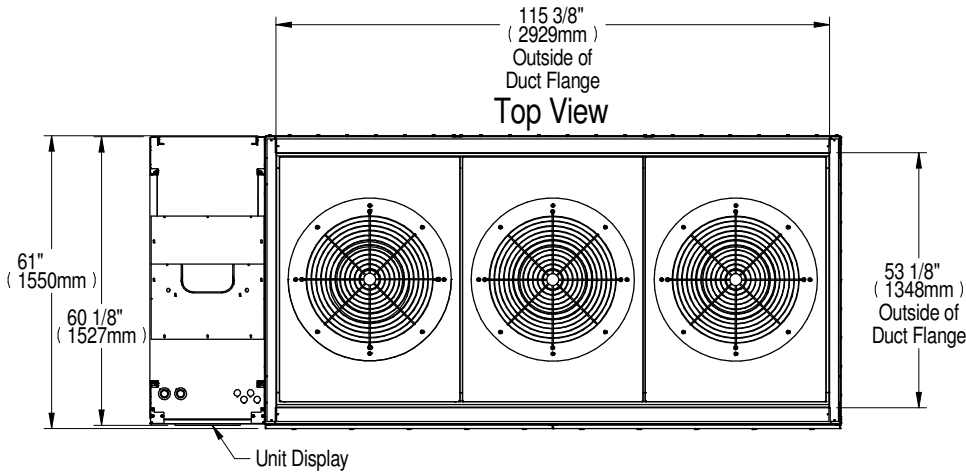

Left Facing Electrical Compartment

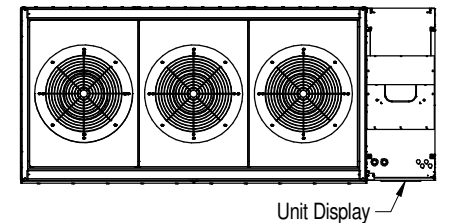

Right Facing Electrical Compartment

**INSTALLATION & SERVICE CLEARANCE DATA CW305-415**  
**PERIMETER INSTALLATION AND SERVICE CLEARANCE HORIZONTAL DISCHARGE**

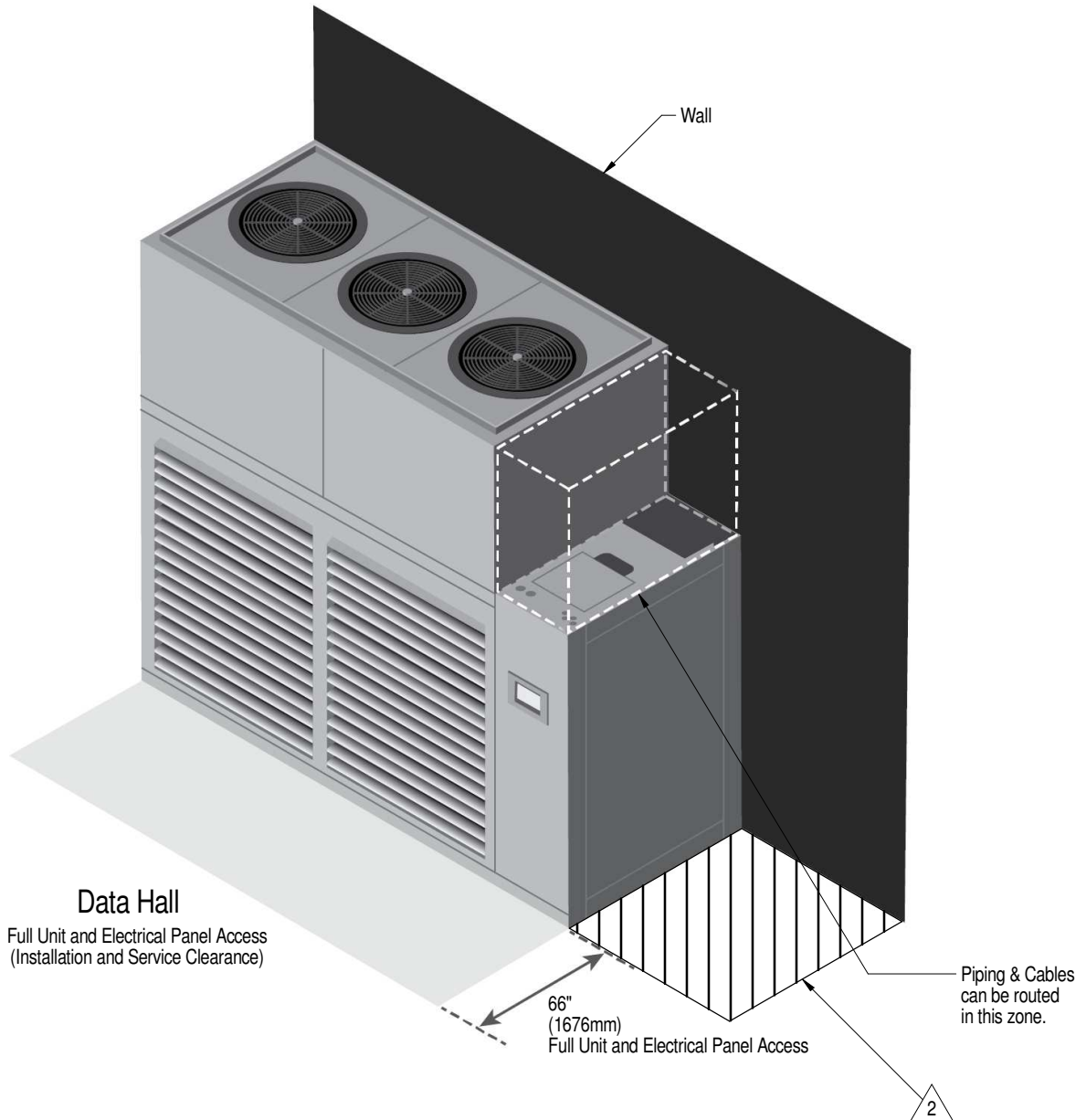

Notes:

1. Electrical Compartment is shown on the right side of the unit. Unit may be ordered with Electrical Compartment on either side, or with Electrical Compartment facing into Gallery Space.
2. Clearance of 36" (914mm) is required during installation on side with electrical compartment.
3. Unit service could require moving adjacent units.

## INSTALLATION & SERVICE CLEARANCE DATA CW305-415

### PERIMETER INSTALLATION AND SERVICE CLEARANCE BOTTOM DISCHARGE

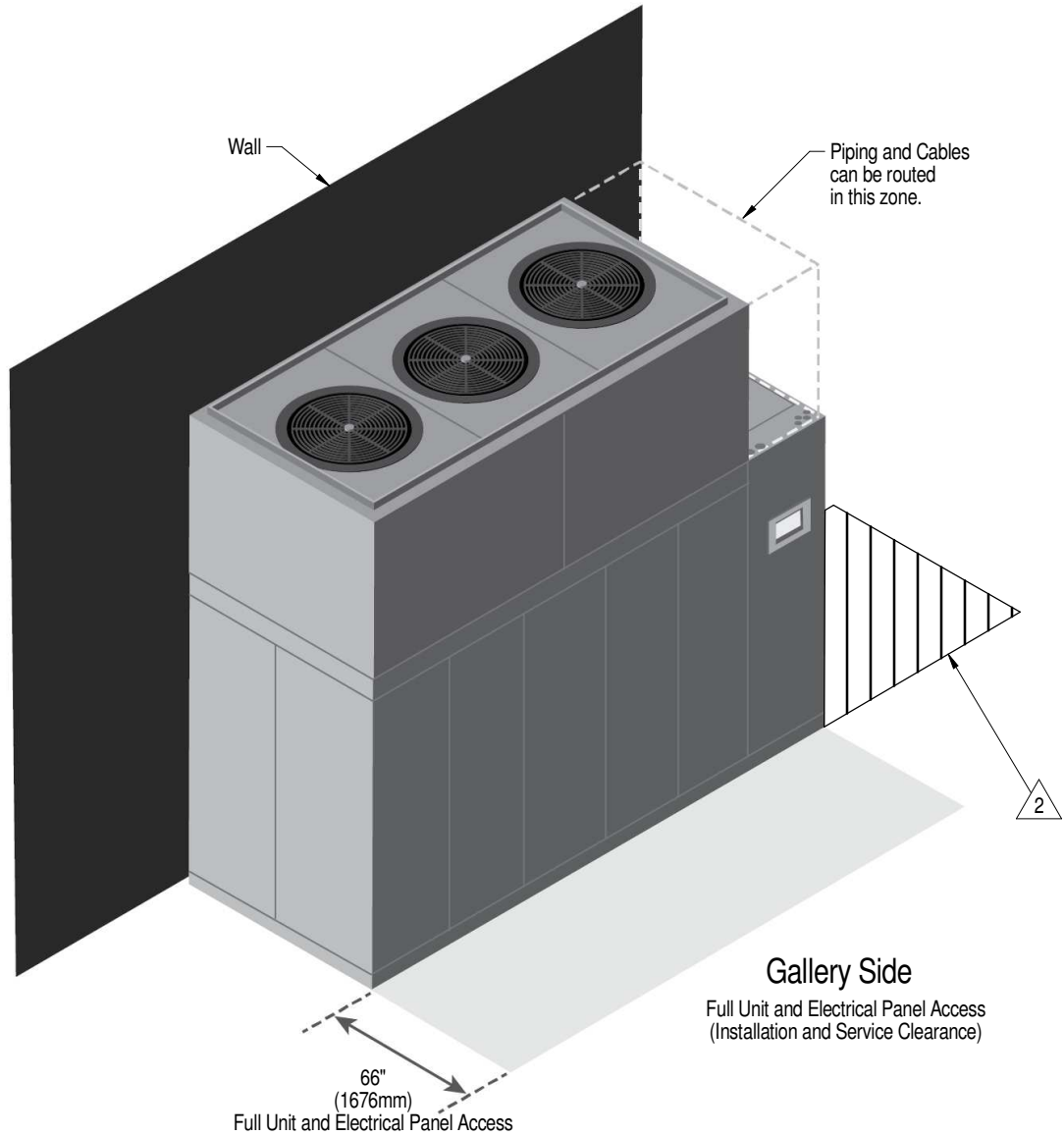

Notes:

1. Electrical Compartment is shown on the right side of the unit. Unit may be ordered with Electrical Compartment on either side, or with Electrical Compartment facing into Data Hall.
2. Clearance of 36" (914mm) is required during installation on side with electrical compartment.
3. Unit service could require moving adjacent units.

**INSTALLATION & SERVICE CLEARANCE DATA CW305-415**  
**GALLERY INSTALLATION AND SERVICE CLEARANCE**

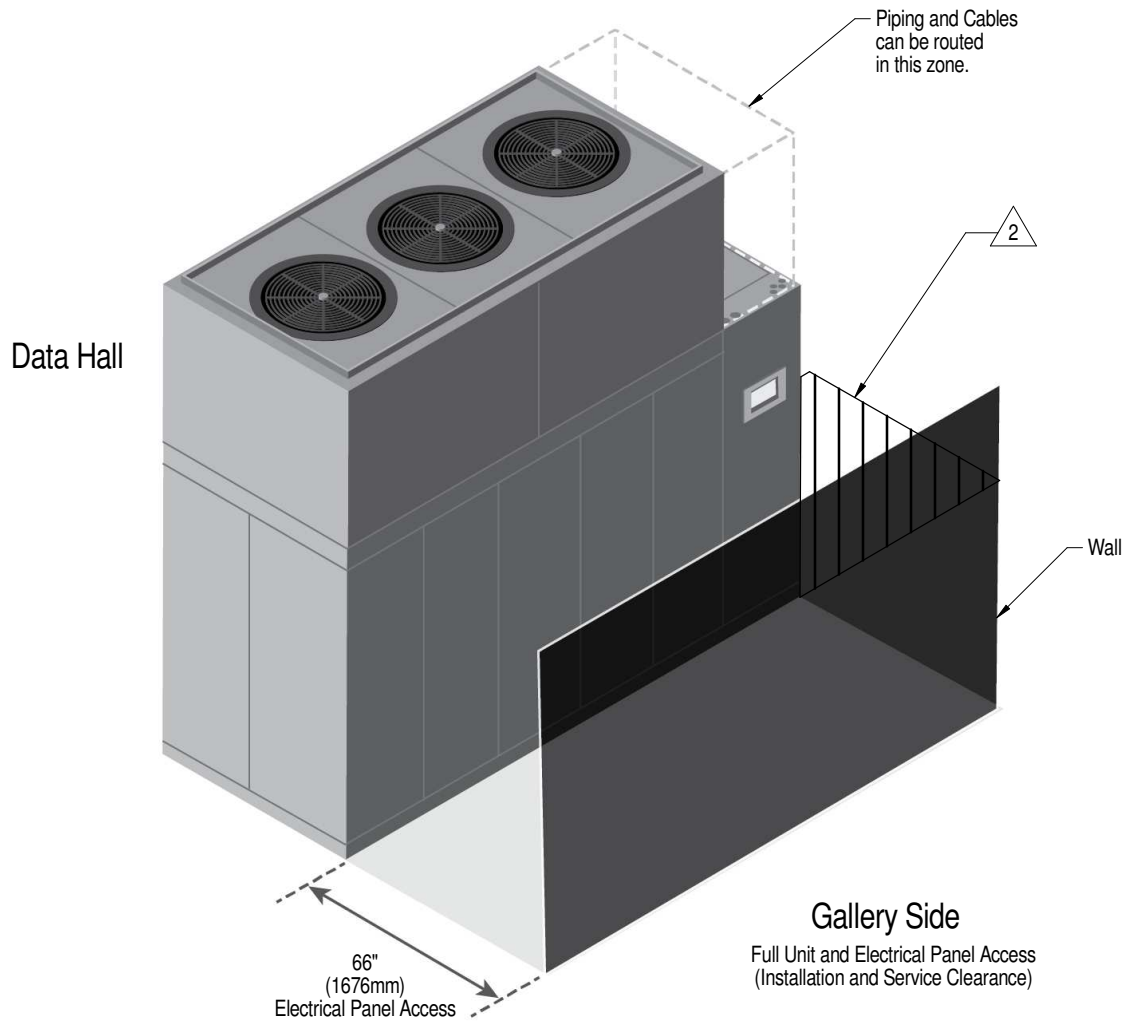

Notes:

1. Electrical Compartment is shown on the left side of the unit. Unit may be ordered with Electrical Compartment on either side, or with Electrical Compartment facing into Data Hall.
2. Clearance of 36" (914mm) is required during installation on side with electrical compartment.
3. Unit service could require moving adjacent units.

## DISASSEMBLY DIMENSIONAL DATA

### CW305, 375, 415

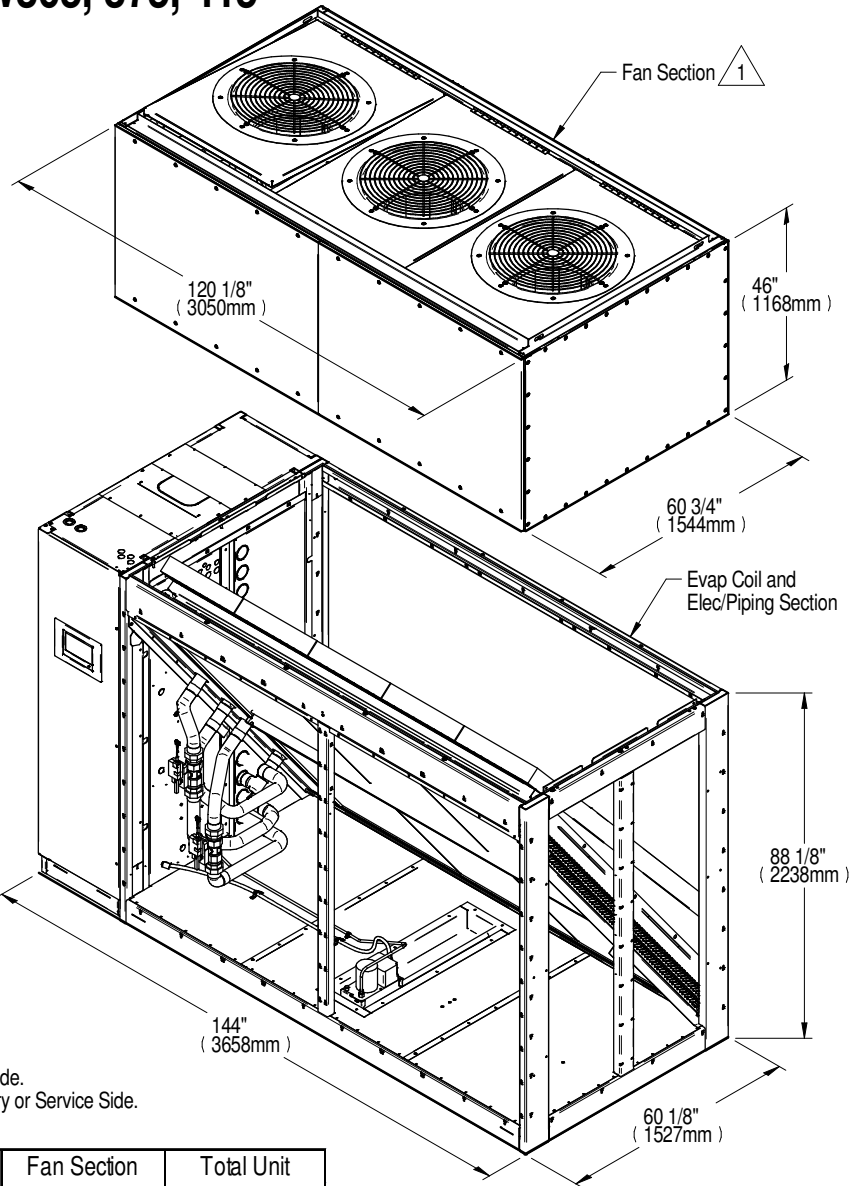
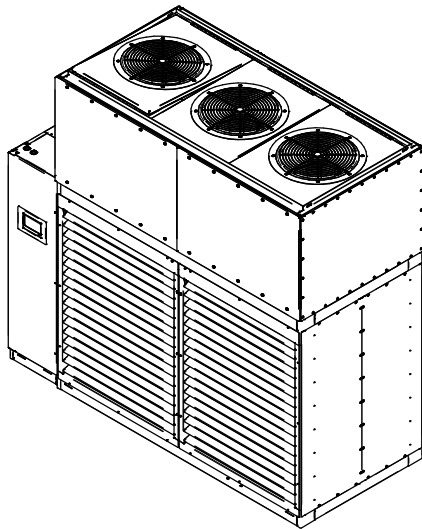

Notes:

- 1. EC Fan Plenum Compartment shipped loose and field assembled.
- 2. Gallery side shown facing front in all views.
- 3. Unit shown with Electrical Compartment on left side facing the Gallery Side. May be ordered with Electrical Compartment on left or right facing Gallery or Service Side.

Evap Coil & Elec/Piping Compartment Weight lbs. (kg)		Fan Section Weight lbs. (kg)	Total Unit Weight lbs. (kg)
4 Row Evap Coil & Elec/Piping Section Horizontal Discharge	3160 (1433)	<div style="display: flex; align-items: center; justify-content: center;"> <div style="border: 1px solid black; padding: 2px; margin-right: 5px;">1</div> <div style="text-align: left;">2325 (1055)</div> </div>	5485 (2488)
6 Row Evap Coil & Elec/Piping Section Horizontal Discharge	3425 (1554)		5750 (2608)
8 Row Evap Coil & Elec/Piping Section Horizontal Discharge	3660 (1660)		5985 (2715)
4 Row Evap Coil & Elec/Piping Section Bottom Discharge	3125 (1747)		5450 (2472)
6 Row Evap Coil & Elec/Piping Section Bottom Discharge	3390 (1538)		5715 (2592)
8 Row Evap Coil & Elec/Piping Section Bottom Discharge	3605 (1635)		5930 (2690)

**FLOOR PLANNING DIMENSIONAL DATA  
FOR ADJACENT CW305, 375, 415 UNITS**

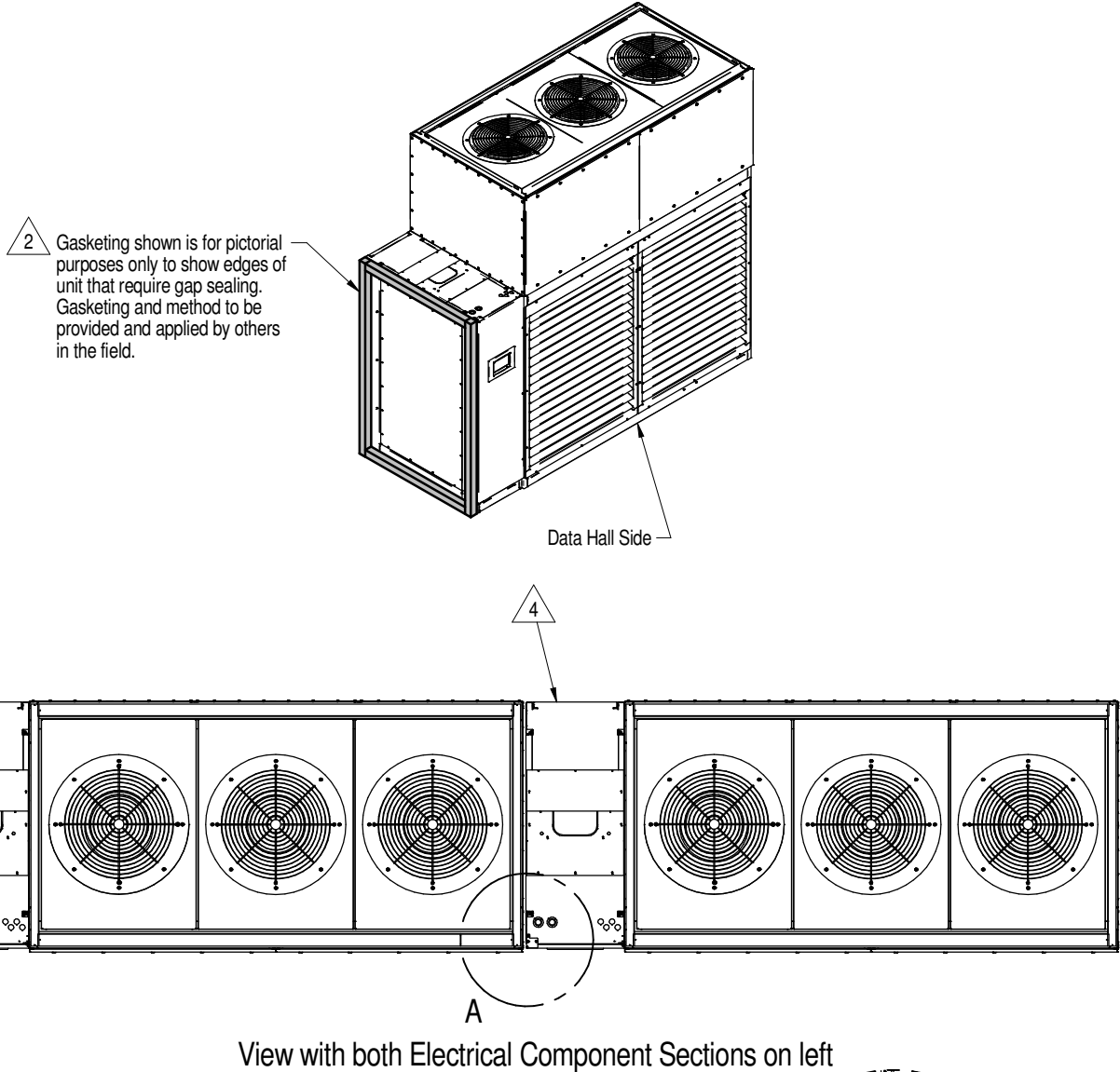

Notes:

1. Gap is measured between frame members of adjacent units.
2. Gasketing required only on shortest section being placed adjacent to another unit.
3. View shows both Electronic Component Sections on the left. The same gasketing instructions apply when both Electronic Component Sections are on the right, or with one on the left and the other on the right.
4. Clearance of 36" (914mm) required for installation before installing adjacent unit.
5. Only two adjacent units are suggested to be installed.

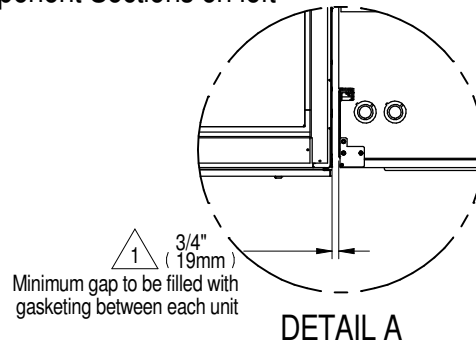

**FLOOR PLANNING DIMENSIONAL DATA  
FOR ADJACENT CW305, 375, 415 UNITS**

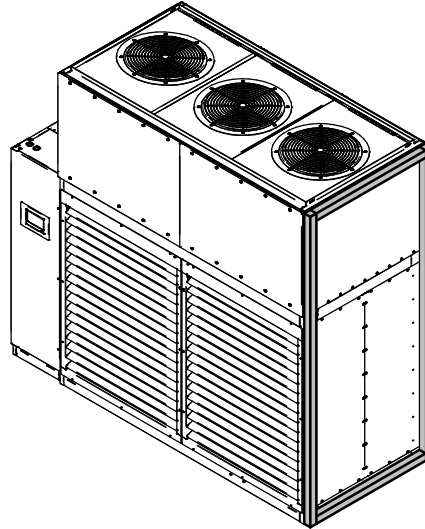

Gasketing shown is for pictorial purposes only to show edges of unit that require gap sealing. Gasketing and method to be provided and applied by others in the field.

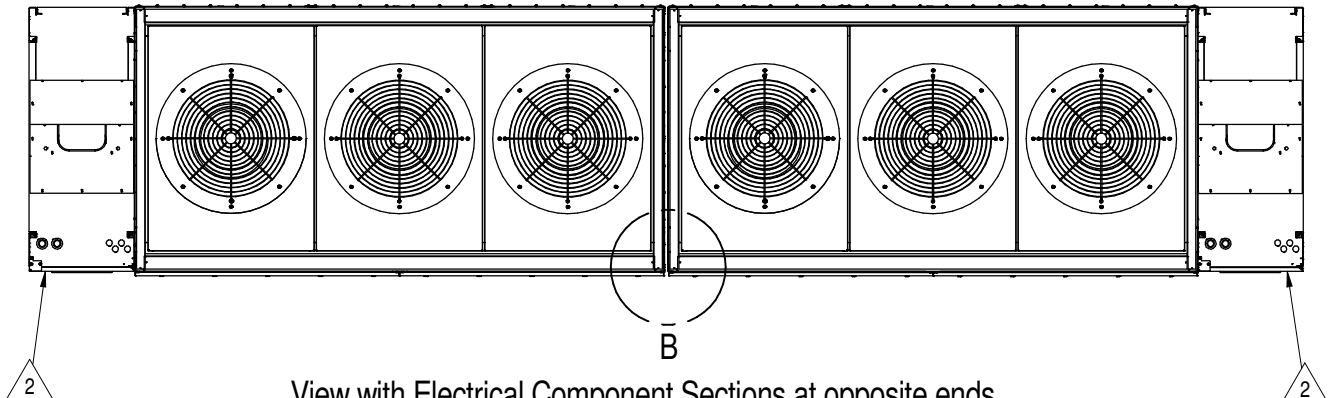

View with Electrical Component Sections at opposite ends

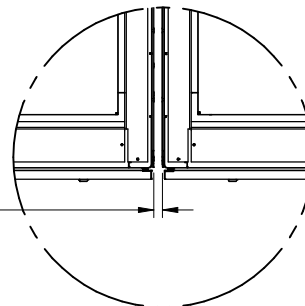

1  $\frac{3}{4}$ " (19mm)  
Minimum gap to be filled with gasketing between each unit

DETAIL B

Notes:

- 1. Gap is measured between frame members of adjacent units.
- 2. Clearance of 36" (914mm) required for installation.
- 3. Only two adjacent units are suggested to be installed.

**FLOORSTAND DIMENSIONAL DATA**  
**CW305, 375, 415**

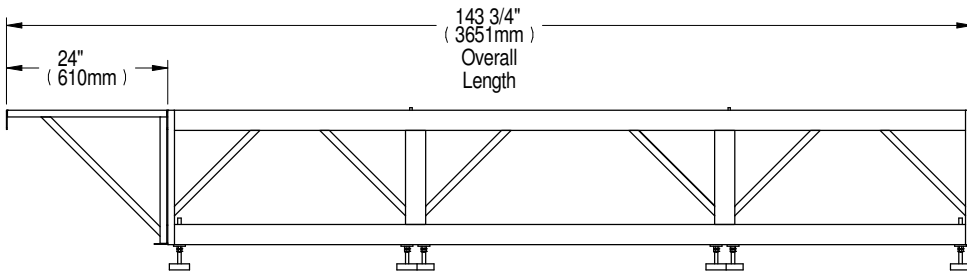
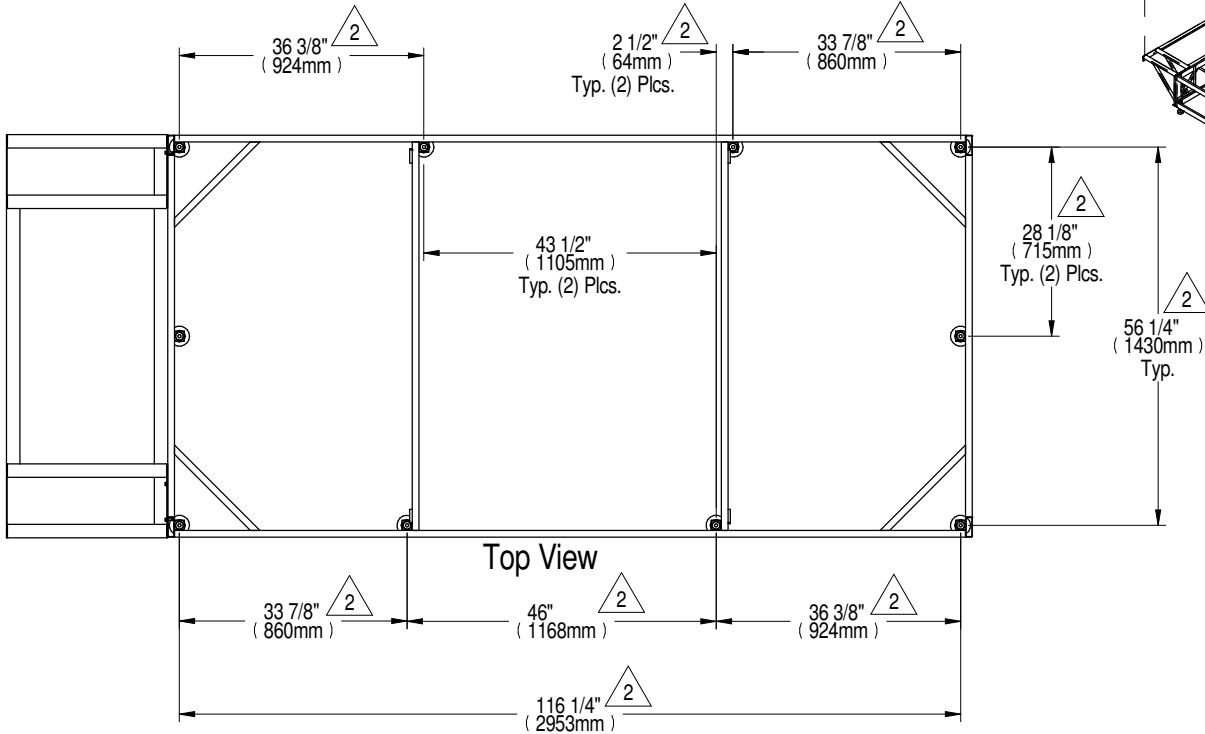
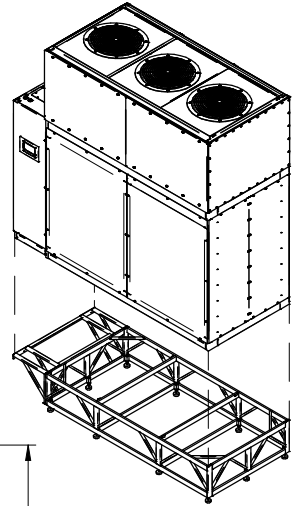

Front View

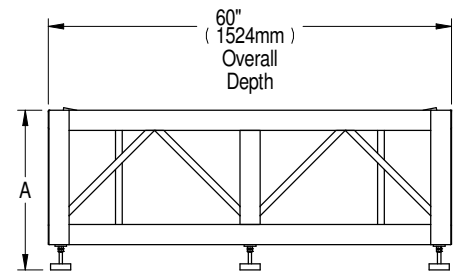

Right Side View

Notes:

1. Leveling feet are provided with  $\pm 1\text{-}1/2$ " (38mm) adjustment from nominal height "A".
2. Dimensions are to center of feet.
3. Floorstand shown in configuration for Electrical Box on the left side of the unit. When unit is ordered with the Electrical Box on the right side of the unit, cantilevered portion of floorstand will appear on the right side.

Height in. ( mm)	
A	$\triangle$
12	(305)
24	(610)
30	(762)
36	(914)
42	(1069)
48	(1219)

**AIRFLOW SCHEMATIC**  
**CW305, 375, 415 W/ HORIZONTAL DISCHARGE**

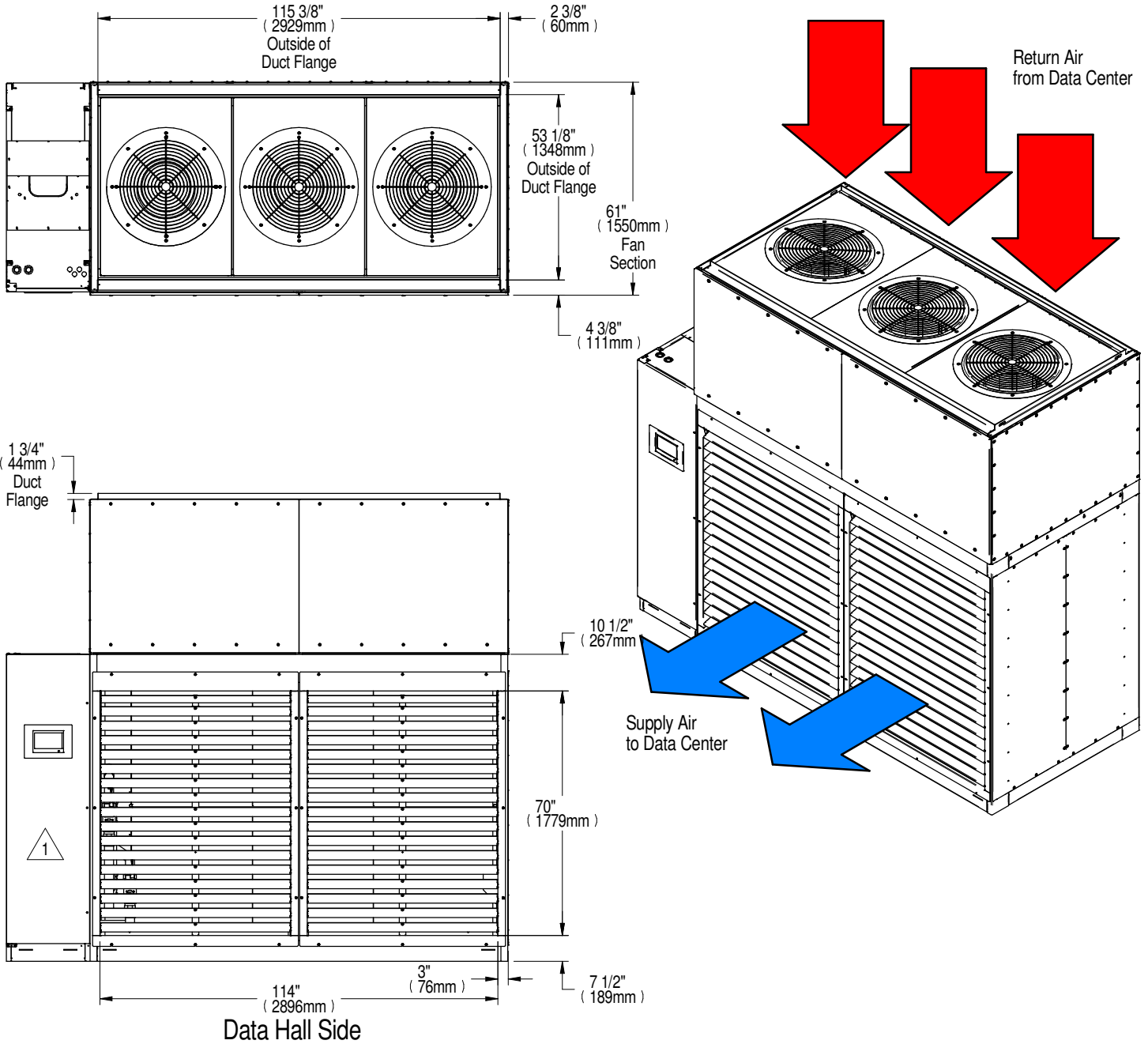

Notes:

1. Electrical Compartment shown on left side of unit. Unit may be ordered with Electrical Compartment on right or left side, or with Electrical Compartment facing into the Gallery space.

**AIRFLOW SCHEMATIC**  
**CW305, 375, 415 W/ BOTTOM DISCHARGE**

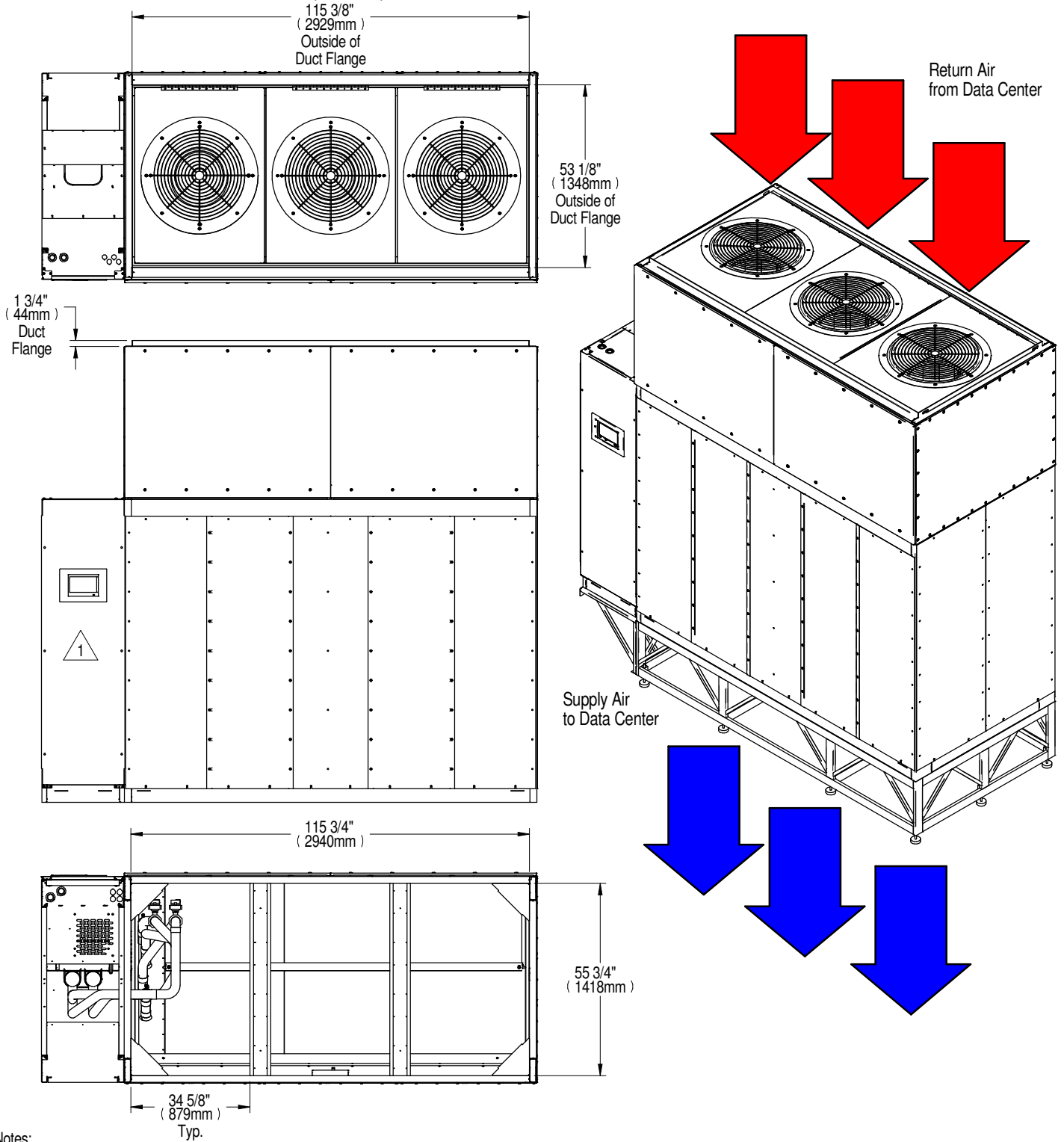

Notes:

- 1. Electrical Compartment shown on left side of unit.  
 Unit may be ordered with Electrical Compartment on right or left side of unit.

## GENERAL ARRANGEMENT DIAGRAM CW305, 375, 415

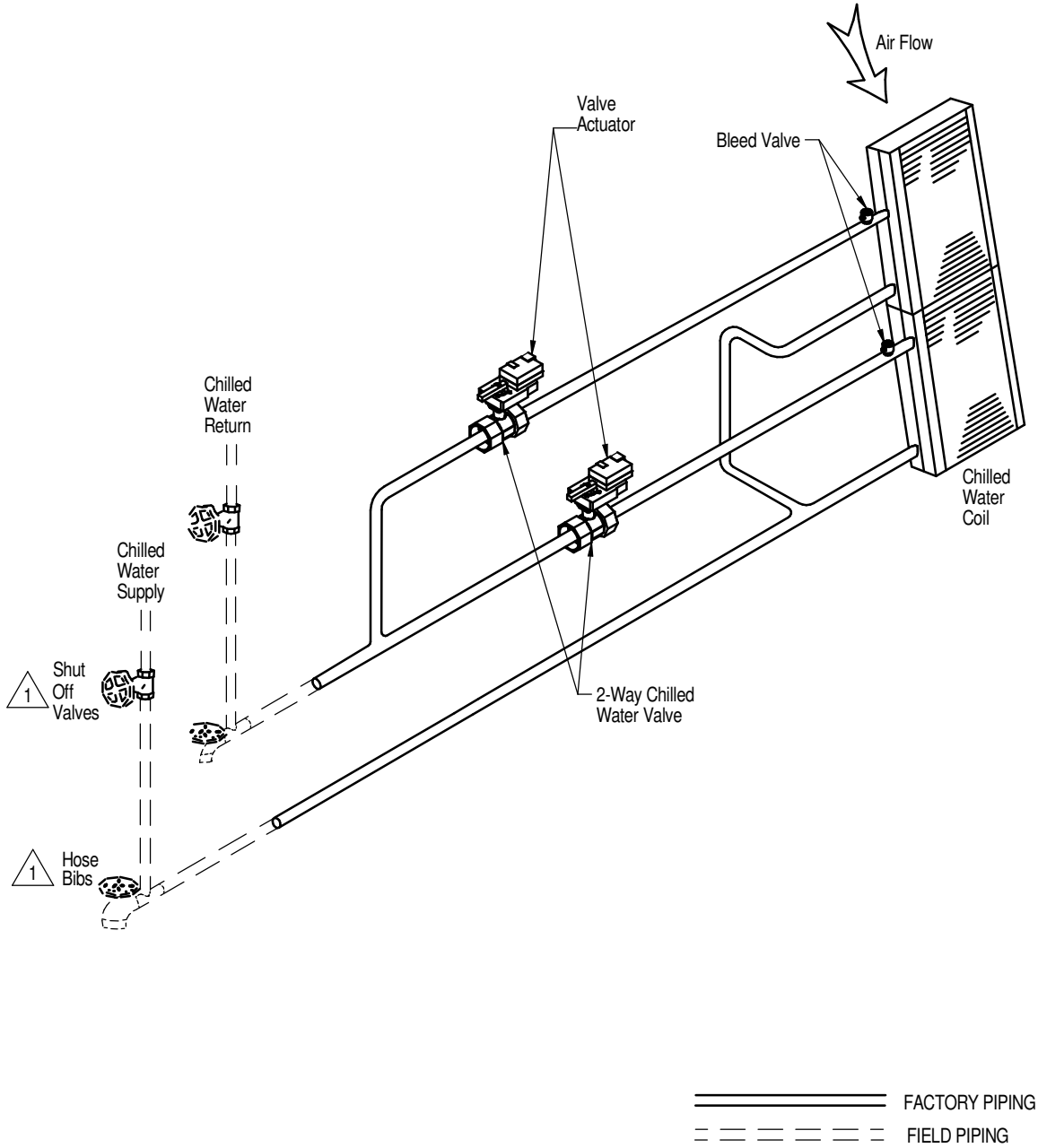

Notes:

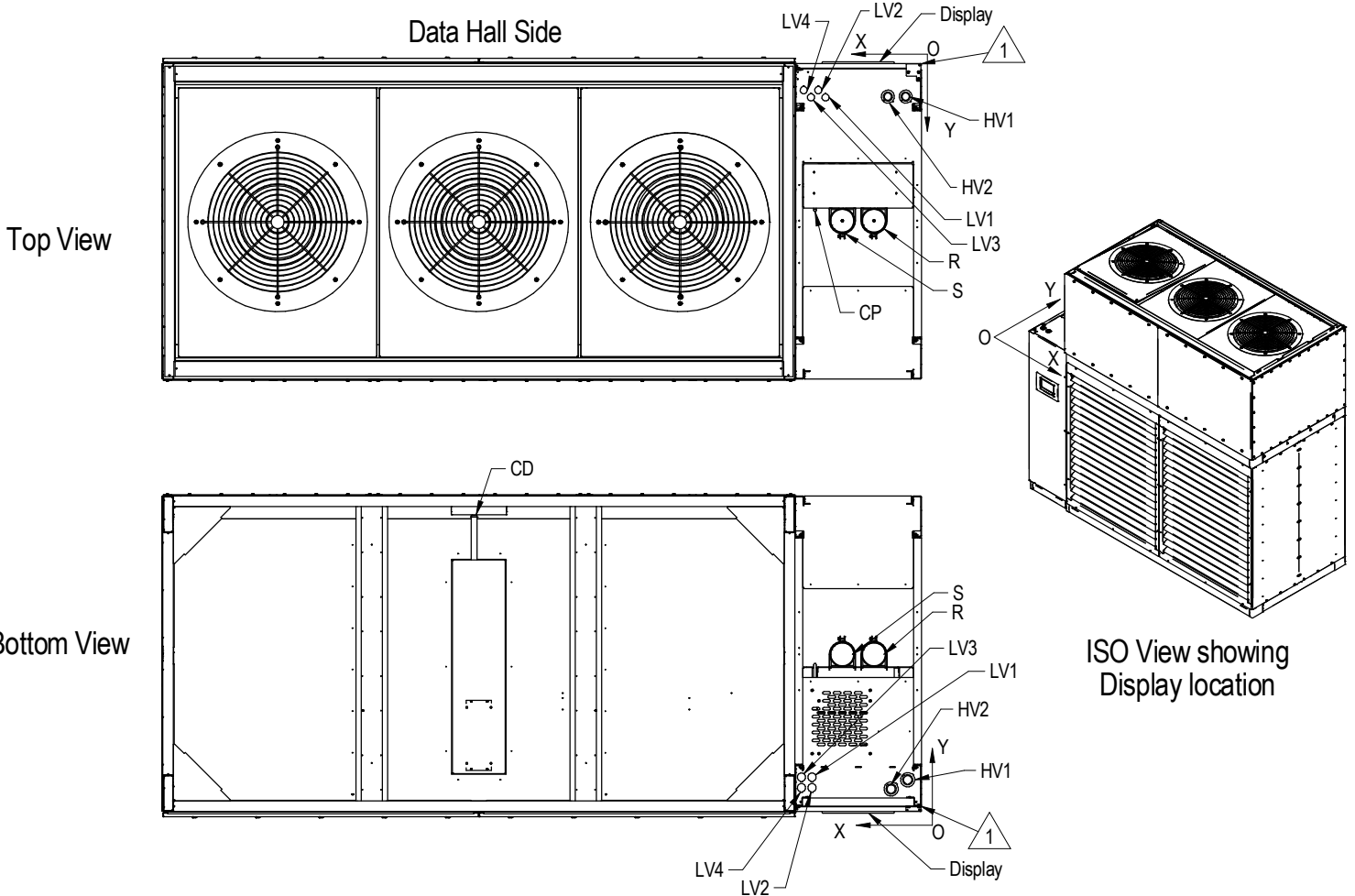

1. Components are not supplied by Vertiv, but are required for proper circuit operation and maintenance.

**PRIMARY CONNECTION LOCATIONS  
CW305, 375, 415 DATA HALL W/ HORIZONTAL DISCHARGE  
LEFT FACING ELECTRICAL/PIPING COMPARTMENT**



POINT	Description	Top View		Bottom View		Connection Size/Opening	
		X in. (mm)	Y in. (mm)	X in. (mm)	Y in. (mm)		
HV1	Electrical Conn. (High Volt)	2-7/8 (73)	6-1/4 (160)	2-1/2 (63)	6 (153)	2-1/2"	
HV2		6-1/4 (159)		5-5/8 (143)	4-1/4 (108)		
LV1	Electrical Conn. (Low Volt)	18-1/8 (459)	6-3/8 (163)	20-5/8 (524)	6-1/2 (165)	1-1/2"	
LV2		19-1/2 (494)			5 (129)		4-1/2 (114)
LV3		20-7/8 (529)			6-3/8 (163)		6-1/2 (165)
LV4		22-1/4 (564)			5 (129)		4-1/2 (114)
CD	Condensate Drain 	N/A	N/A	84-1/2 (2146)	55-1/2 (1410)	3/4" NPT Female	
CP	Condensate Pump	20 (509)	27-7/8 (707)	N/A	N/A	1/2" O.D. Cu	
S	Supply Pipe Connection	15 (381)	30 (762)	15 (381)	30 (762)	4-1/8" O.D. Cu	
R	Return Pipe Connection	9 (229)		9 (229)			

Notes:

1.  Drawing not to scale. All dimensions from left corner on service side and have a tolerance of  $\pm 1/2"$  (13mm).
2.  Field pitch Condensate Drain line a minimum of 1/8" (3.2mm) per 12" (305mm). Install an external 5-1/2" (140mm) trap in the drain line (if desired). The factory unit does not contain a trap. Select appropriate drain system materials. The drain must comply with all local codes.
3. Piping connection can be made at the top or bottom of the unit.

**PRIMARY CONNECTION LOCATIONS  
CW305, 375, 415 W/ BOTTOM DISCHARGE  
RIGHT FACING ELECTRICAL/PIPING COMPARTMENT**

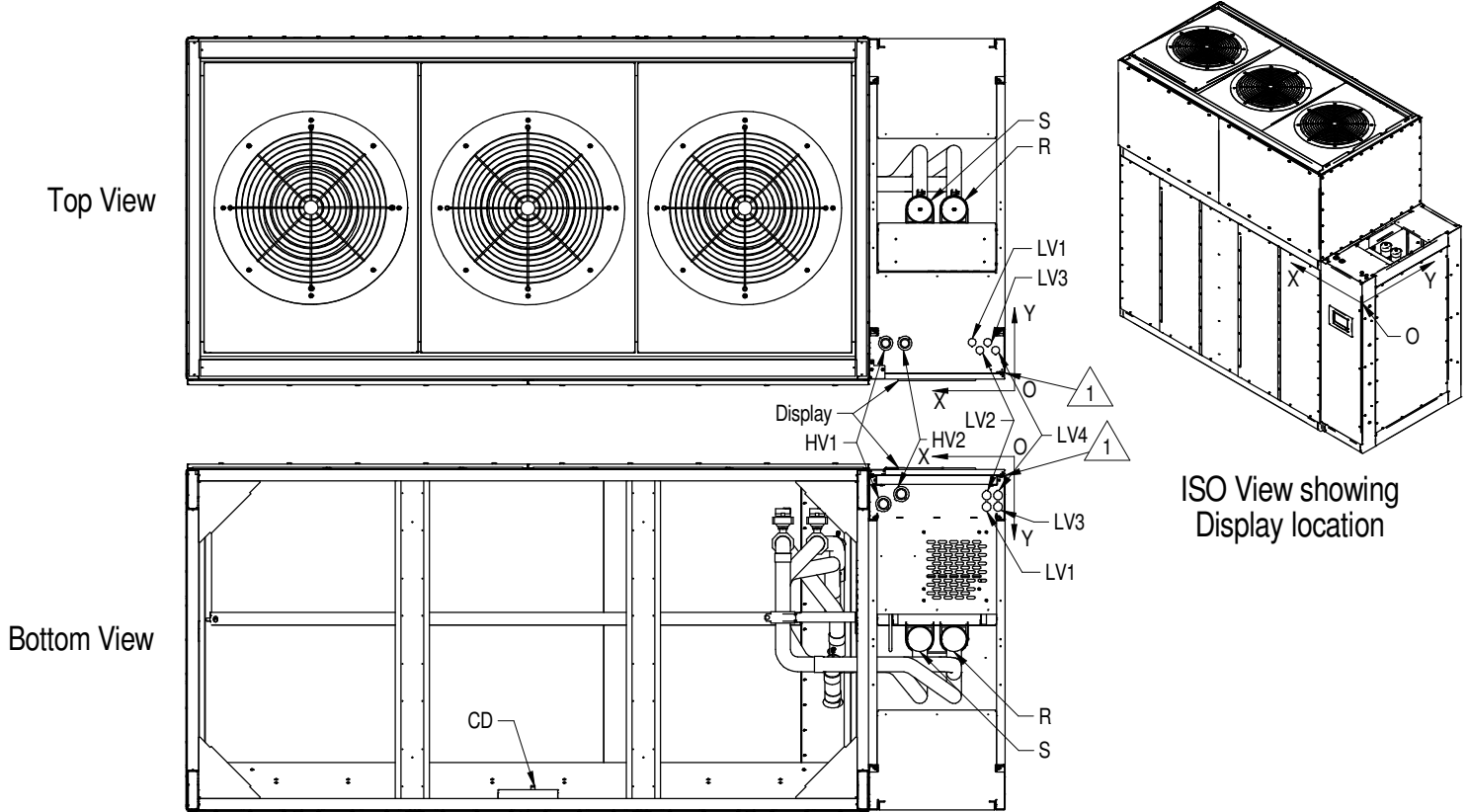

POINT	Description	Top View		Bottom View		Connection Size/Opening
		X in. (mm)	Y in. (mm)	X in. (mm)	Y in. (mm)	
HV1	Electrical Conn. (High Volt)	21 (533)	6-1/4 (159)	21-3/8 (543)	5 (127)	2-1/2"
HV2		17-5/8 (448)		18-1/4 (464)	3-1/4 (83)	
LV1	Electrical Conn. (Low Volt)	5-3/4 (148)	6-3/8 (162)	3-1/4 (83)	5-1/2 (140)	1-1/2"
LV2		4-3/8 (113)	5 (127)	1-1/4 (32)	3-1/2 (89)	
LV3		3 (78)	6-3/8 (162)	3-1/4 (83)	5-1/2 (140)	
LV4		1-5/8 (43)	5 (127)	1-1/4 (32)	3-1/2 (89)	
CD	Condensate Drain <sup>3</sup>	N/A	N/A	83 (2108)	54-1/2 (1384)	3/4" NPT Female
CP	Condensate Pump			<sup>2</sup>	<sup>2</sup>	1/2" O.D. Cu
S	Supply Pipe Connection			15 (381)	28-3/4 (731)	4-1/8 O.D. Cu
R	Return Pipe Connection			9 (229)		

Notes:

- <sup>1</sup> Drawing not to scale. All dimensions from right corner on service side and have a tolerance of  $\pm 1/2"$  (13mm).
- <sup>2</sup> Condensate Pump to be field located and installed by customer.
- <sup>3</sup> Field pitch Condensate Drain line a minimum of 1/8" (3.2mm) per 12" (305mm). Install an external 5-1/2" (140mm) trap in the drain line (if desired). The factory unit does not contain a trap. Select appropriate drain system materials. The drain must comply with all local codes.
4. Piping connection can be made at the top or bottom of the unit.

**PRIMARY CONNECTION LOCATIONS**  
**CW305, 375, 415 DATA HALL W/ HORIZONTAL DISCHARGE**  
**RIGHT FACING ELECTRICAL/PIPING COMPARTMENT**

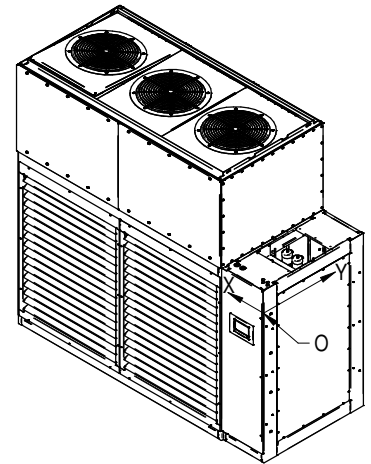
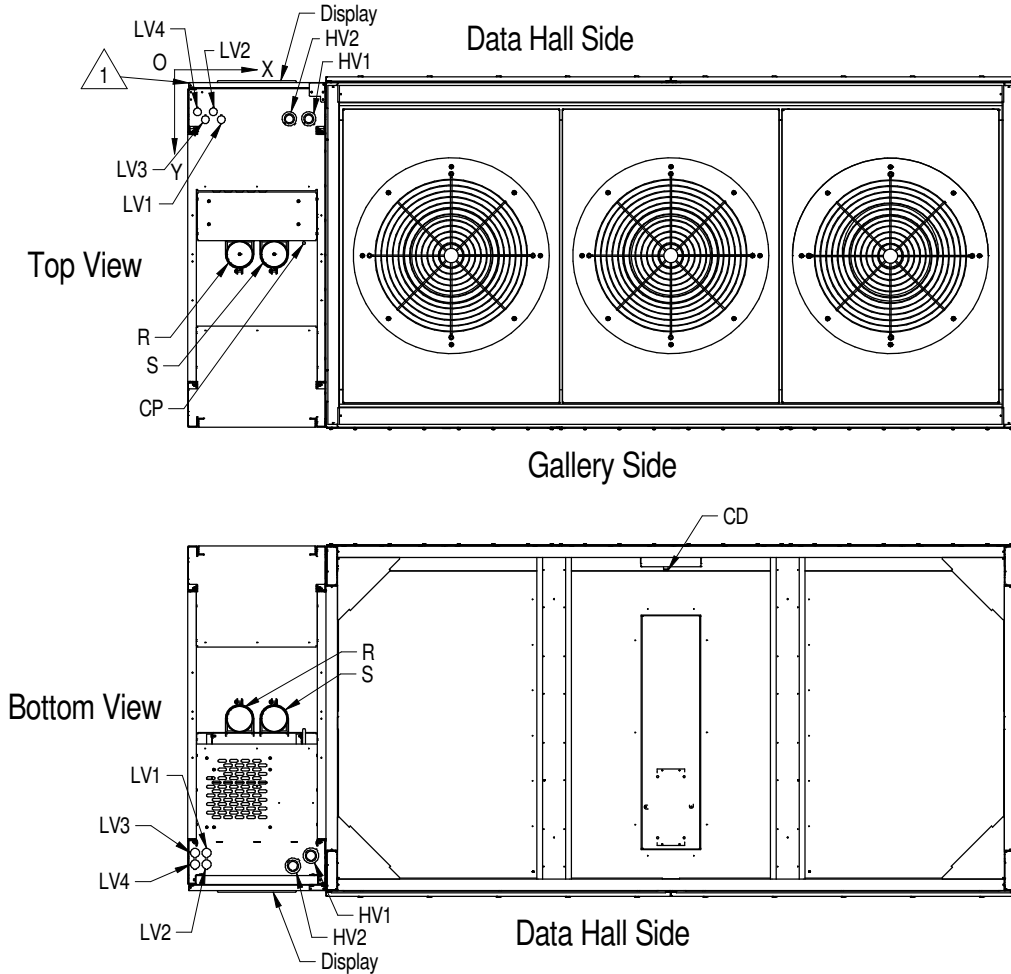

POINT	Description	Top View		Bottom View		Connection Size/Opening
		X in. (mm)	Y in. (mm)	X in. (mm)	Y in. (mm)	
HV1	Electrical Conn. (High Volt)	20-1/8 (513)	6-1/4 (160)	21-1/4 (540)	6 (153)	2-1/2"
HV2		17-1/2 (444)		18-1/8 (460)	4-1/4 (109)	
LV1	Electrical Conn. (Low Volt)	5-5/8 (144)	6-3/8 (163)	3-1/8 (79)	6-1/2 (166)	1-1/2"
LV2		4-1/4 (109)			5 (129)	
LV3		2-7/8 (75)	6-3/8 (163)		6-1/2 (166)	
LV4		1-1/2 (40)	5 (129)		4-1/2 (115)	
CD	Condensate Drain <sup>2</sup>	N/A	N/A	82-7/8 (2105)	55-1/2 (1410)	3/4" NPT Female
CP	Condensate Pump	20 (509)	27-7/8 (707)	N/A	N/A	1/2" O.D. Cu
S	Supply Pipe Connection	N/A	N/A	14-7/8 (378)	30 (762)	4-1/8" O.D. Cu
R	Return Pipe Connection			8-7/8 (225)		

Notes:

1. Drawing not to scale. All dimensions from right corner on service side and have a tolerance of  $\pm 1/2"$  (13mm).
2. Field pitch Condensate Drain line a minimum of  $1/8"$  (3.2mm) per 12" (305mm). Install an external 5-1/2" (140mm) trap in the drain line (if desired). The factory unit does not contain a trap. Select appropriate drain system materials. The drain must comply with all local codes.
3. Piping connection can be made at the top or bottom of the unit.

**PRIMARY CONNECTION LOCATIONS  
CW305, 375, 415 W/ BOTTOM DISCHARGE  
LEFT FACING ELECTRICAL/PIPING COMPARTMENT**

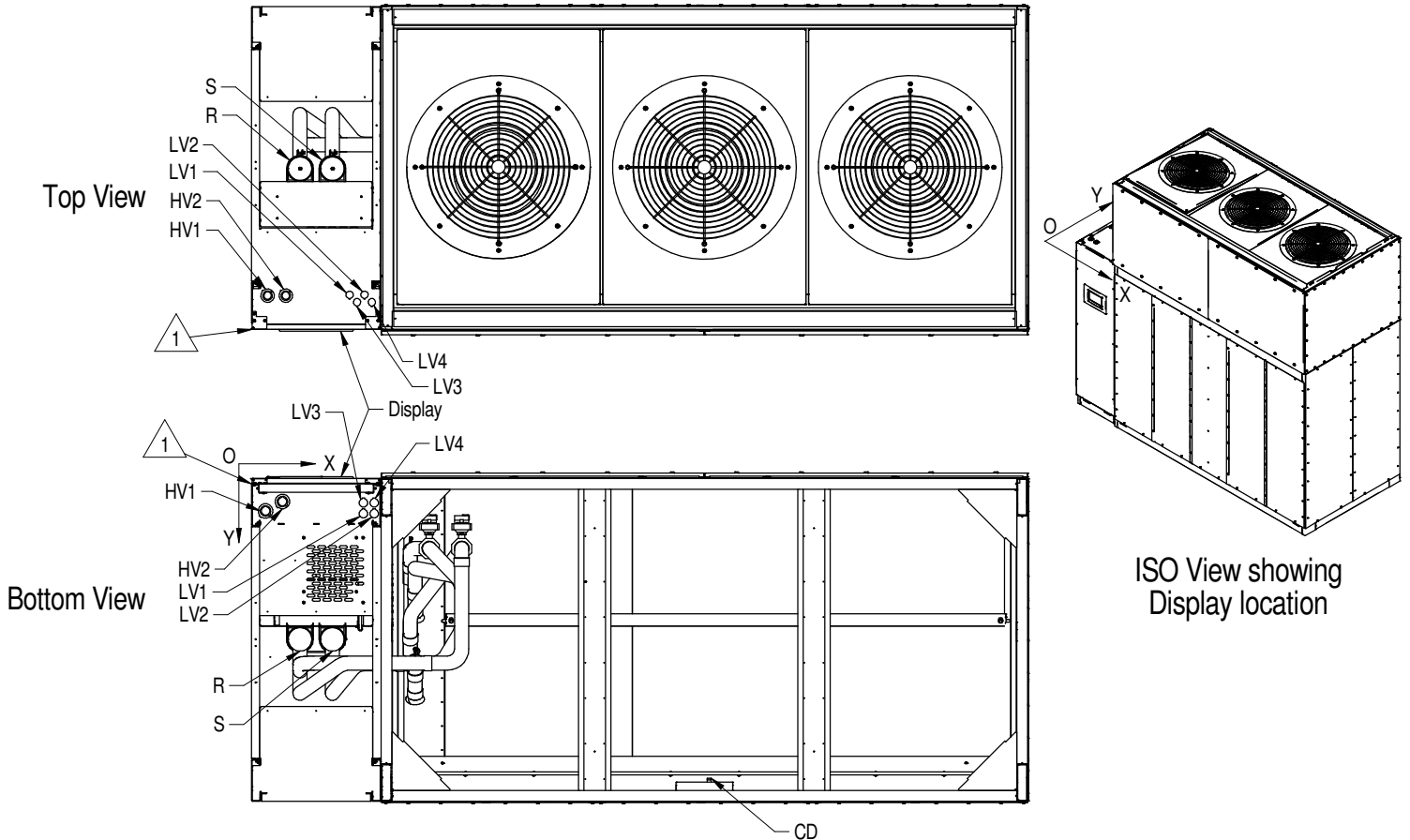

POINT	Description	Top View		Bottom View		Connection Size/Opening	
		X in. (mm)	Y in. (mm)	X in. (mm)	Y in. (mm)		
HV1	Electrical Conn. (High Volt)	2-7/8 (73)	6-1/4 (160)	2-1/2 (64)	5 (127)	2-1/2"	
HV2		6-1/4 (159)		5-5/8 (143)	3-1/4 (83)		
LV1	Electrical Conn. (Low Volt)	18-1/8 (459)	6-3/8 (163)	20-5/8 (524)	5-1/2 (140)	1-1/2"	
LV2		19-1/2 (494)			5 (129)		3-1/2 (89)
LV3		20-7/8 (529)			6-3/8 (163)		5-1/2 (140)
LV4		22-1/4 (564)			5 (129)		3-1/2 (89)
CD	Condensate Drain <sup>3</sup>			84-5/8 (2149)	54-1/2 (1384)	3/4" NPT Female	
CP	Condensate Pump <sup>2</sup>	N/A	N/A	<sup>2</sup>	<sup>2</sup>	1/2" O.D. Cu	
S	Supply Pipe Connection			15 (381)	28-3/4 (731)	4-1/8" O.D. Cu	
R	Return Pipe Connection			9 (229)			

Notes:

- <sup>1</sup> Drawing not to scale. All dimensions from right corner on service side and have a tolerance of  $\pm 1/2"$  (13mm).
- <sup>2</sup> Condensate Pump to be field located and installed by customer.
- <sup>3</sup> Field pitch Condensate Drain line a minimum of 1/8" (3.2mm) per 12" (305mm).  
Install an external 5-1/2" (140mm) trap in the drain line (if desired). The factory unit does not contain a trap. Select appropriate drain system materials.  
The drain must comply with all local codes.
4. Piping connection can be made at the top or bottom of the unit.

**PRIMARY CONNECTION LOCATIONS  
CW305, 375, 415 GALLERY W/ HORIZONTAL DISCHARGE  
RIGHT FACING ELECTRICAL/PIPING COMPARTMENT**

Data Hall Side

Top View

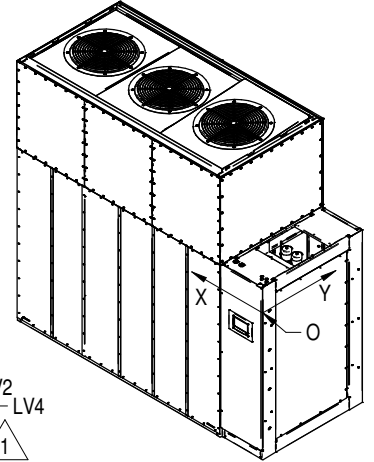
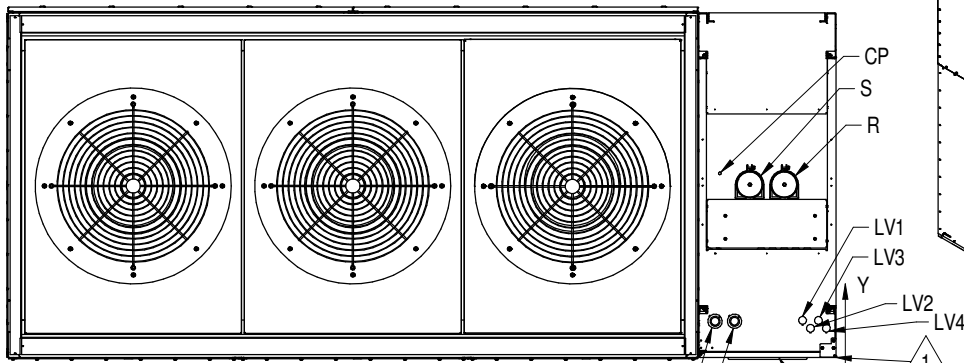

ISO View showing Display location

Gallery Side

Bottom View

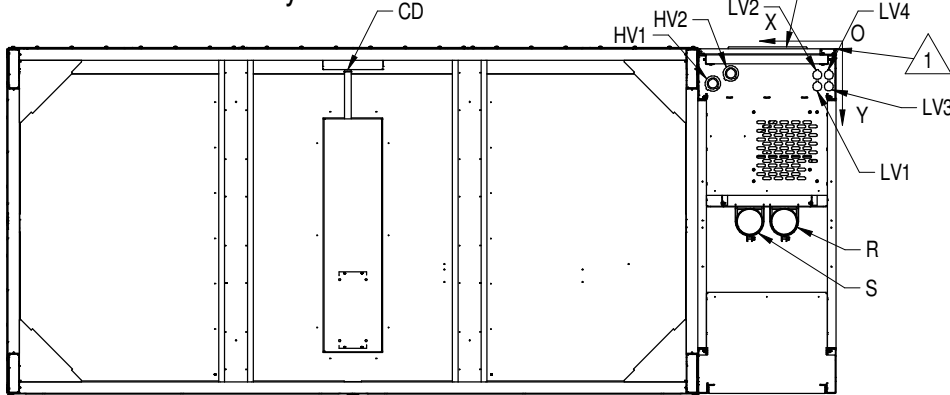

Data Hall Side

POINT	Description	Top View		Bottom View		Connection Size/Opening
		X in. (mm)	Y in. (mm)	X in. (mm)	Y in. (mm)	
HV1	Electrical Conn. (High Volt)	21 (533)	6-1/4 (160)	21-3/8 (543)	6 (153)	2-1/2"
HV2		17-5/8 (448)		18-1/4 (464)	4-1/4 (109)	
LV1	Electrical Conn. (Low Volt)	5-3/4 (148)	6-1/2 (164)	3-1/4 (83)	6-1/2 (166)	1-1/2"
LV2		4-3/8 (113)			5-1/8 (129)	
LV3		3 (78)	6-1/2 (164)	1-1/4 (32)	6-1/2 (166)	
LV4		1-1/2 (37)	5-1/8 (129)		4-1/2 (115)	
CD	Condensate Drain <sup>2</sup>	N/A	N/A	84-3/4 (2153)	3-5/8 (94)	3/4" NPT Female
CP	Condensate Pump	20-1/8 (512)	27-7/8 (708)	N/A	N/A	1/2" O.D. Cu
S	Supply Pipe Connection	N/A	N/A	15 (381)	30 (762)	4-1/8" O.D. Cu
R	Return Pipe Connection			9 (229)		

Notes:

1. Drawing not to scale. All dimensions from right corner on service side and have a tolerance of  $\pm 1/2"$  (13mm).
2. Field pitch Condensate Drain line a minimum of  $1/8"$  (3.2mm) per 12" (305mm). Install an external 5-1/2" (140mm) trap in the drain line (if desired). The factory unit does not contain a trap. Select appropriate drain system materials. The drain must comply with all local codes.
3. Piping connection can be made at the top or bottom of the unit.

**PRIMARY CONNECTION LOCATIONS  
CW305, 375, 415 GALLERY W/ HORIZONTAL DISCHARGE  
LEFT FACING ELECTRICAL/PIPING COMPARTMENT**

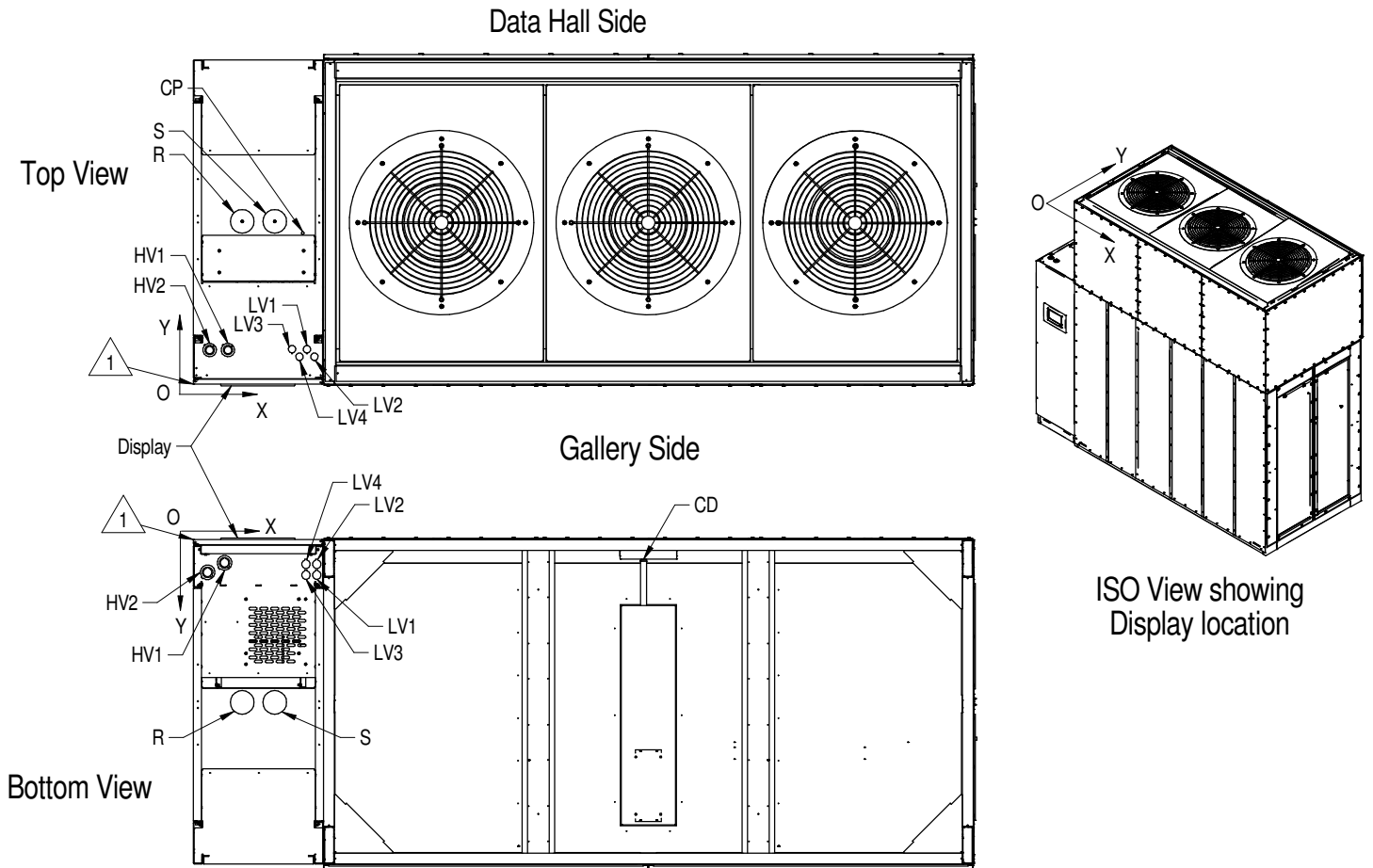

POINT	Description	Top View		Bottom View		Connection Size/Opening
		X in. (mm)	Y in. (mm)	X in. (mm)	Y in. (mm)	
HV1	Electrical Conn. (High Volt)	6-3/8 (162)	6-1/4 (160)	5-3/4 (146)	6 (153)	2-1/2"
HV2		3 (76)		2-5/8 (67)	4-1/4 (109)	
LV1	Electrical Conn. (Low Volt)	21 (532)	6-1/2 (164)	22-3/4 (578)	6-1/2 (166)	1-1/2"
LV2		22-3/8 (567)		5-1/8 (129)	4-1/2 (115)	
LV3		18-1/4 (462)		6-1/2 (164)	6-1/2 (166)	
LV4		19-5/8 (497)		5-1/8 (129)	4-1/2 (115)	
CD	Condensate Drain <sup>2</sup>	N/A	N/A	83 (2108)	3-5/8 (94)	3/4" NPT Female
CP	Condensate Pump	20-1/8 (512)	27-7/8 (708)	N/A	N/A	1/2" O.D. Cu
S	Supply Pipe Connection	N/A	N/A	15 (381)	30 (762)	4-1/8" O.D. Cu
R	Return Pipe Connection			9 (229)		

Notes:

1. Drawing not to scale. All dimensions from right corner on service side and have a tolerance of  $\pm 1/2"$  (13mm).
2. Field pitch Condensate Drain line a minimum of  $1/8"$  (3.2mm) per 12" (305mm). Install an external 5-1/2" (140mm) trap in the drain line (if desired). The factory unit does not contain a trap. Select appropriate drain system materials. The drain must comply with all local codes.
3. Piping connection can be made at the top or bottom of the unit.

**GRAVITY DRAIN INSTALLATION  
CW305-415 UNITS**

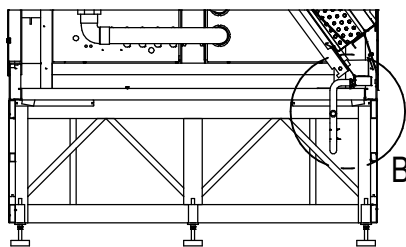
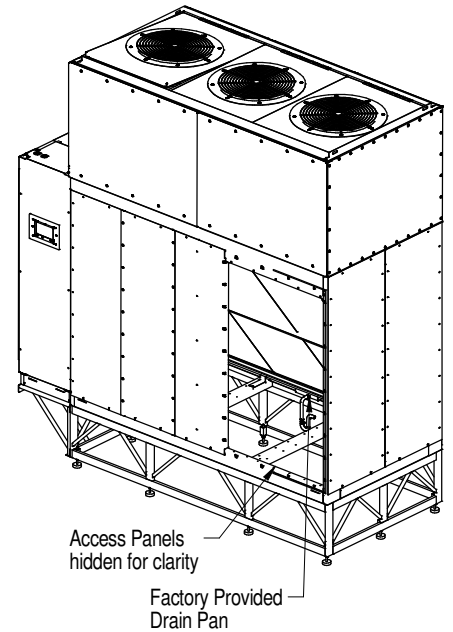
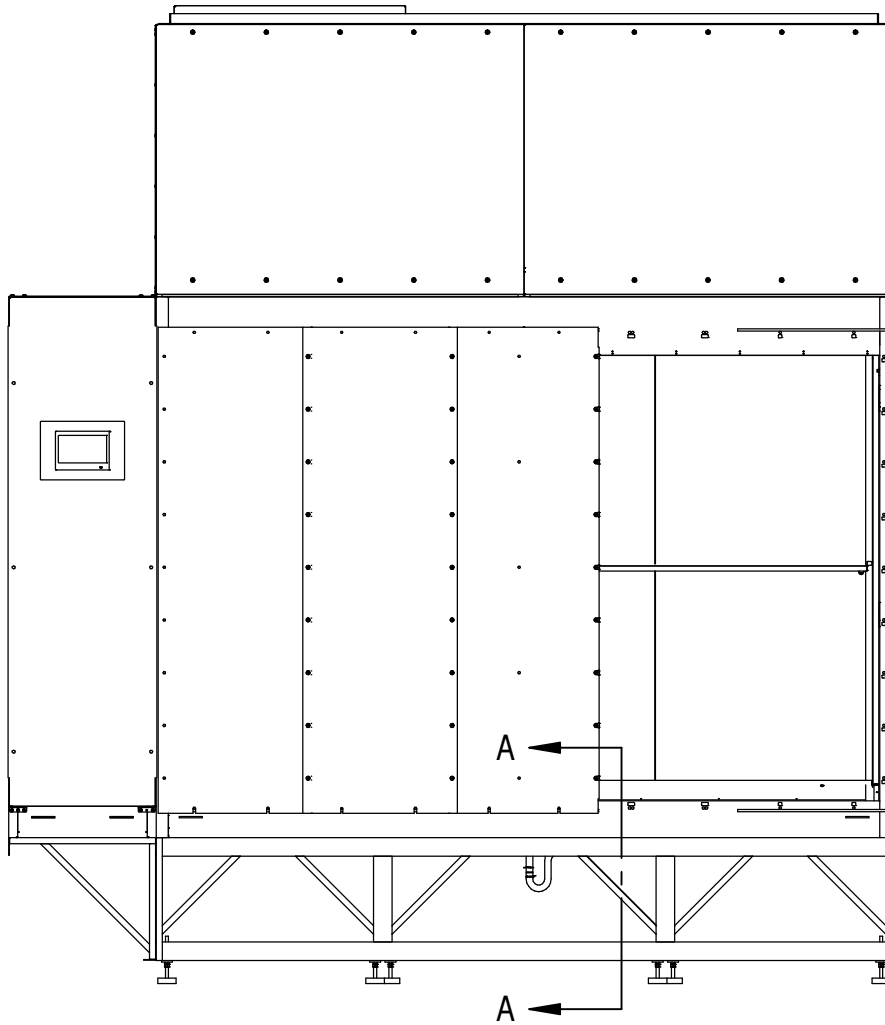

SECTION A-A

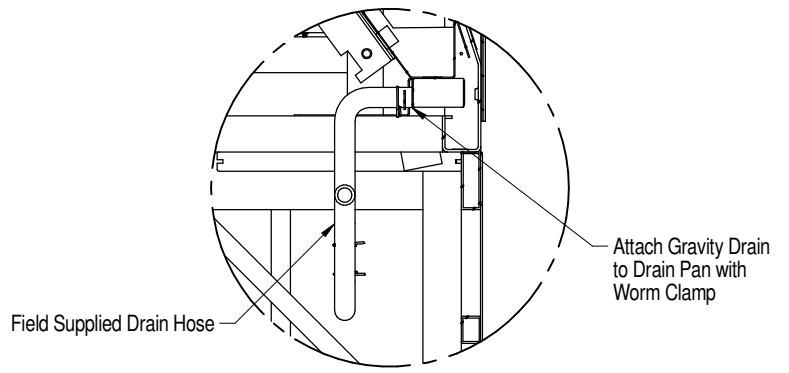

DETAIL B

**CONDENSATE PUMP INSTALLATION  
CW305-415 DOWNFLOW UNITS**

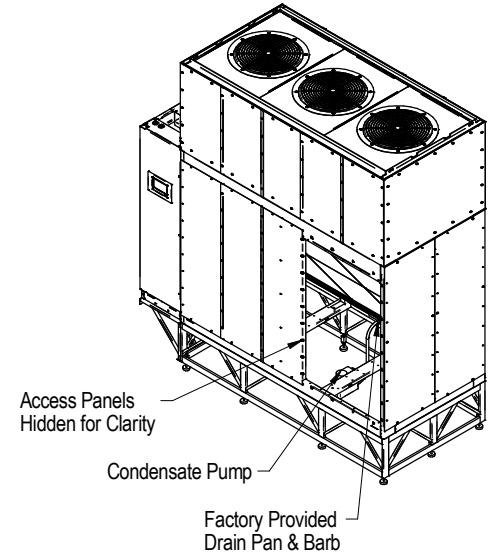
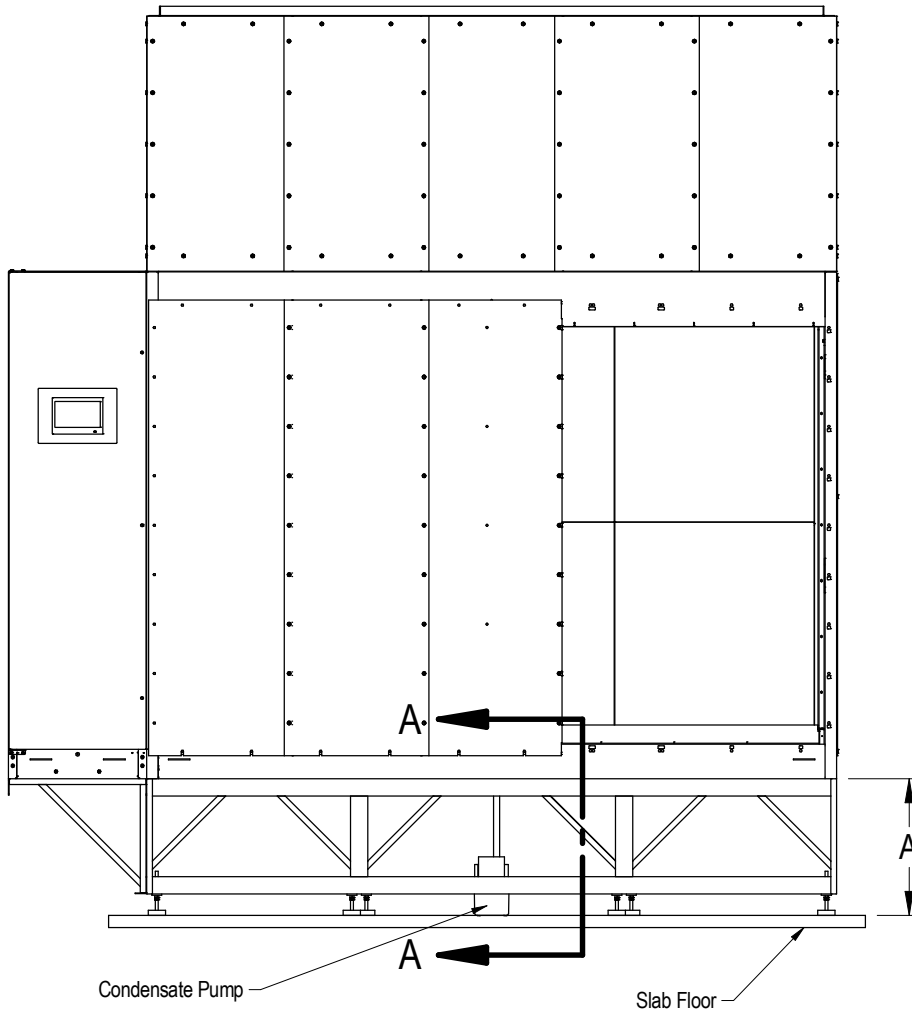

Floorstand Height A - in. (mm)	Distance from Drain Connection to Top of Condensate Pump H - in. (mm)
12 (305)	15 (381)
24 (610)	27 (686)
30 (762)	33 (838)
36 (914)	39 (991)
42 (1069)	45 (1143)
48 (1219)	51 (1295)

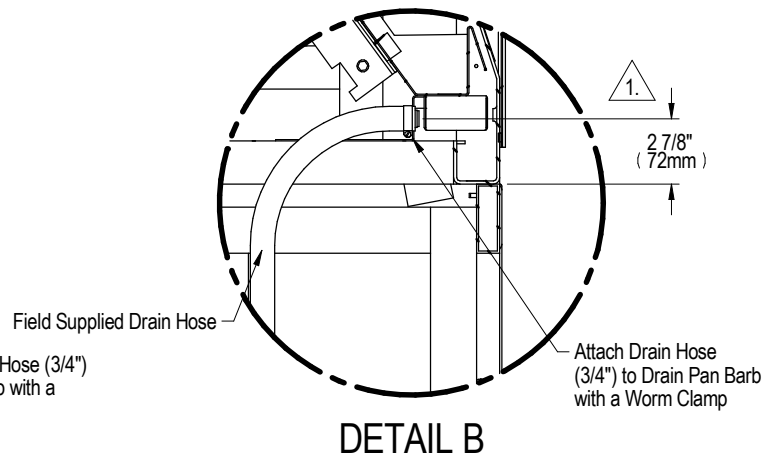
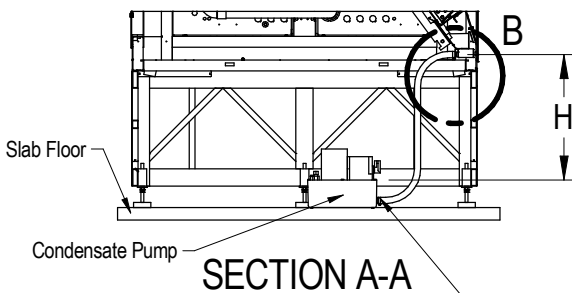

Notes:

1. Dimension is from centerline of the drain pan outlet to the bottom of the unit.
2. Field wiring is required between the condensate pump and the high voltage electrical enclosure, and must be per local code.



# LIEBERT® CW

---

## ELECTRICAL FIELD CONNECTIONS CW305, 375, 415 DOWNFLOW MODELS

### STANDARD ELECTRICAL CONNECTIONS

1. High voltage entrance - Located in bottom and top of box (quantity 2). Raceway in front left corner of enclosure for routing high voltage wires thru enclosure.
2. Low voltage entrance – Located in bottom and top of box (quantity 4). Raceway in front right corner of enclosure for routing low voltage wires thru enclosure.
3. Three phase electrical service - Terminals are on top of disconnect switch. Three phase service not provided by Liebert.
4. Earth ground - Terminal for field supplied earth grounding wire and component ground terminal strip. Earth grounding required for Vertiv units.
5. Unit factory installed disconnect switch and Main Fuses – Access to the high voltage electric panel compartment can be obtained only with the switch in the “off” position. Fused disconnects are provided with a defeater button that allows access to the electrical panel when power is on.
6. Remote unit shutdown - Replace existing jumper between terminals 37 & 38 with field supplied normally closed switch having a minimum 75VA, 24VAC rating. Use field supplied Class 1 wiring.
7. Customer alarm inputs - Terminals for field supplied, normally open contacts, having a minimum 75VA, 24VAC rating, between terminals 24 & 50, 51, 55, 56. Use field supplied Class 1 wiring. Terminal availability varies by unit options.
8. Common alarm - On any alarm, normally open dry contact is closed across terminals 75 & 76 for remote indication. 1 AMP, 24VAC max load. Use Class 1 field supplied wiring.

---

## **ELECTRICAL FIELD CONNECTIONS**

### **CW305, 375, 415 DOWNFLOW MODELS**

#### **OPTIONAL ELECTRICAL CONNECTIONS**

9. Condensate alarm (with condensate pump option) - On pump high water indication, normally open dry contact is closed across terminals 88 & 89 for remote indication. 1 AMP, 24VAC max load. Use Class 1 field supplied wiring.
10. Remote humidifier - On any call for humidification, normally open dry contact is closed across terminals 11 & 12 to signal field supplied remote humidifier. 1 AMP, 24VAC max load. Use Class 1 field supplied wiring
11. Reverse Starter contacts - Normally open dry contact is closed across terminals 102 & 103 for power supply 1 and 106 & 107 for power supply 2 to indicate the active power feed. 1 AMP, 24VAC max load. Use Class 1 field supplied wiring.
12. Smoke sensor alarm - Factory wired dry contacts from smoke sensor are 91-common, 92-NO, and 93-NC. Supervised contacts, 80 & 81, open on sensor trouble indication. This smoke sensor is not intended to function as, or replace, any room smoke detection system that may be required by local or national codes. 1 AMP, 24VAC max load. Use Class 1 field supplied wiring.
13. Analog inputs- Terminals 41, 42, 43, and 44 are user configurable for 0-10V, 0-5V, or 4-20MA.

#### **OPTIONAL LOW VOLTAGE TERMINAL PACKAGE CONNECTIONS**

14. Remote unit shutdown - Two additional contact pairs available for unit shutdown (labeled as 37B & 38B, 37C & 38C). Replace jumpers with field supplied normally closed switch having a minimum 75VA, 24VAC rating. Use field supplied Class 1 wiring.
15. Common alarm - On any alarm, two additional normally open dry contacts are closed across terminals 94 & 95 and 96 & 97 for remote indication. 1 AMP, 24VAC max load. Use Class 1 field supplied wiring.
16. Main fan enabled contact - On VFD enable, normally open dry contact is closed across terminals 84 & 85 for remote indication. 1 AMP, 24VAC max load. Use Class 1 field supplied wiring.
17. Liebert® Liqui-Tect™ shutdown and dry contact - On activation of Liebert® Liqui-Tect™, normally open dry contact is closed across terminals 58 & 59 for remote indication (Liebert® Liqui-Tect™ sensor ordered separately). 1 AMP, 24VAC max load. Use Class 1 field supplied wiring.

#### **OPTIONAL COMMUNICATION CONNECTIONS**

18. Unit-to-Unit – Plug 64 is reserved for U2U communication
19. Site and BMS – Plug 74 and terminal block 3 are reserved for Site and BMS connections. Plug 74 is an eight pin RJ45 for a Cat 5 cable. Terminal block 3 is a two position screw terminal block for use with twisted pair wires.

## ELECTRICAL FIELD CONNECTIONS CW305, 375, 415 DOWNFLOW MODELS

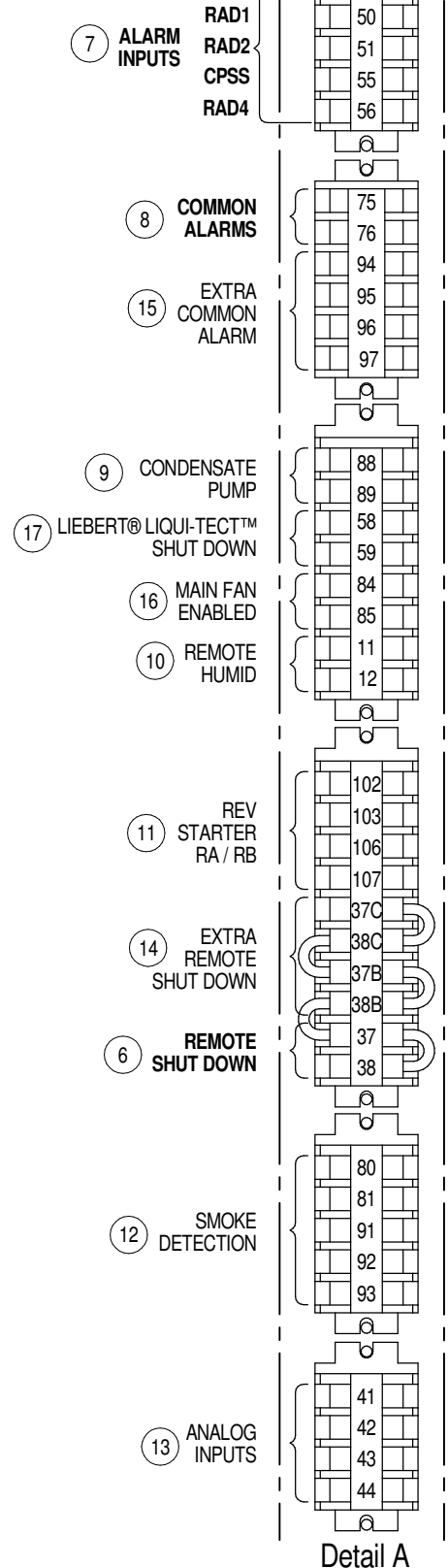
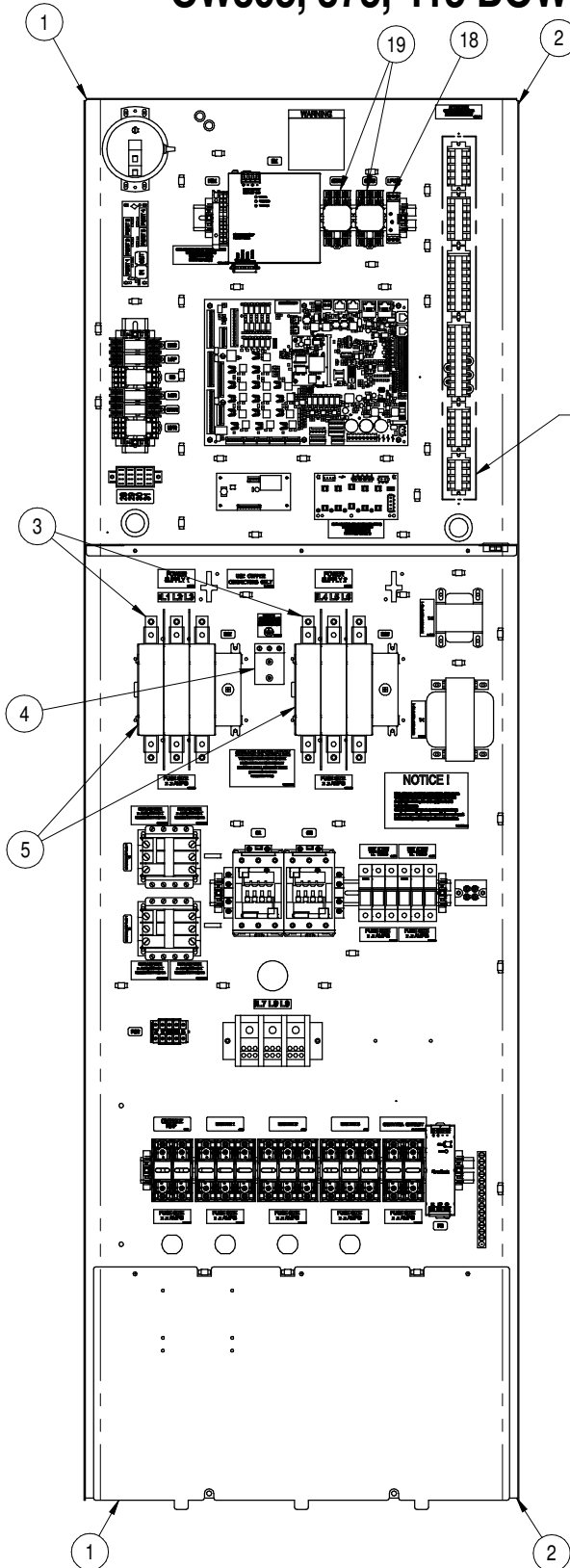

Detail A

# AUTOMATIC TRANSFER SWITCH

## CONTROL MODULE

### OVERVIEW OF LOVATO ATS, MODELS ATL610 & ATL800

Vertiv™ Thermal Management units equipped with the optional Lovato ATS (automatic transfer switch) control, will automatically switch over to a secondary power source upon loss of primary power. It will also return to the primary power source when it is determined it is available.

When units are equipped with the optional Capacitive Buffer feature, it will not only keep the Vertiv™ iCOM™ control powered (minimum of 3 minutes) during a loss of power, but will also keep the ATS electronics powered when neither the primary or secondary source are available, allowing for a quick unit response when power is restored.

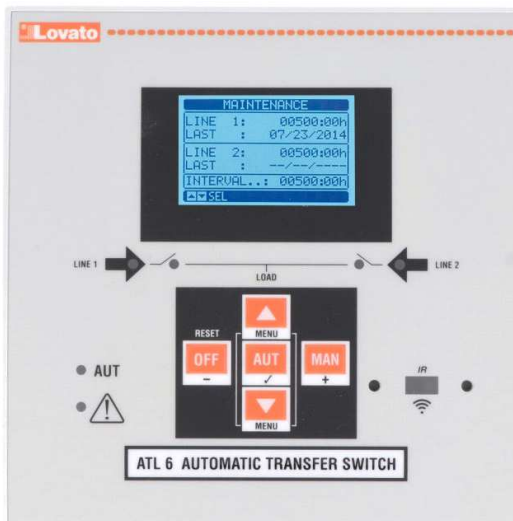

**ATL610 (Units up to 460V)**

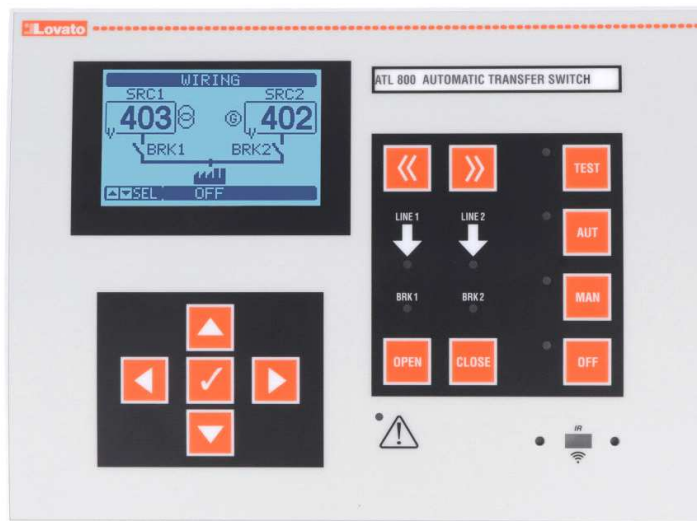

**ATL800 (575V Units)**

Lovato ATS, model ATL610 (or ATL800) shown in images above, will be located within the cabinet of the units.

# AUTOMATIC TRANSFER SWITCH

## CONTROL MODULE

### KEY CAPABILITIES OF LOVATO ATS, MODELS ATL610 & ATL800

The Lovato ATS, model ATL610 (or ATL800), will be the primary unit level device for switching between power sources. This control will be capable of the following features:

- Determine if power is available in both primary and secondary sources
- Allow for selection of which source is primary and which is secondary
- Ability to automatically switch from primary to secondary source, in the event of primary power loss
- Ability to automatically switch secondary to primary source when primary power returns
- Visible indication of available power sources
- Visible indication of power source that is currently active

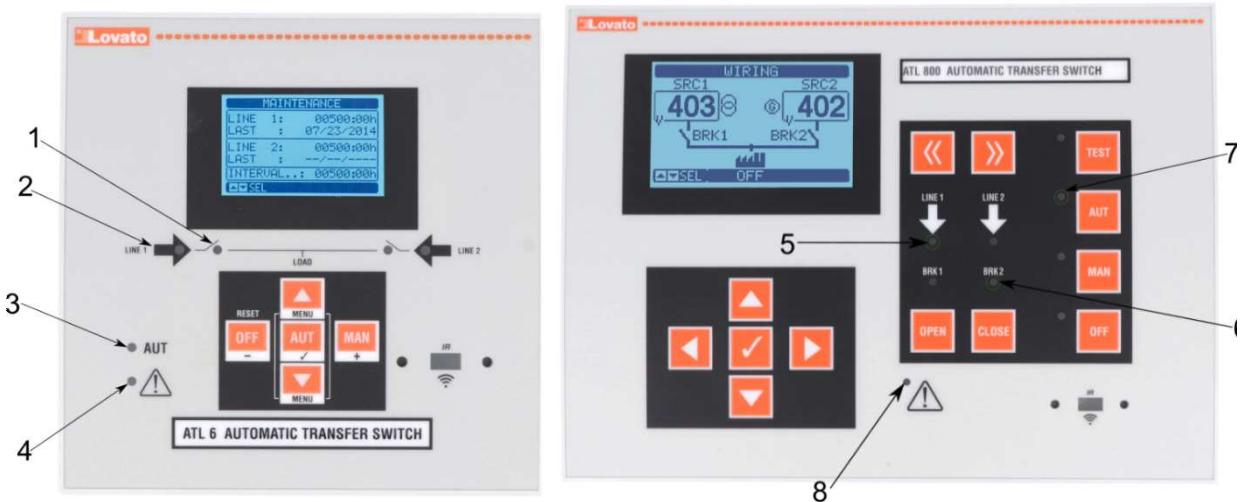

Item #	Description for ATL610 Display	Item #	Description for ATL800 Display
1	LEDs indicate which source is active	5	LEDs indicate if a source is available
2	LEDs indicate if a source is available	6	LEDs indicate which source is active
3	Controller is in automatic mode	7	Controller is in automatic mode
4	Alarm is present	8	Alarm is present

**ATL610 (Units up to 460V)**

**ATL800 (575V Units)**

# AUTOMATIC TRANSFER SWITCH

## CONTROL MODULE

### INTERACTION OF LOVATO ATS WITH VERTIV™ iCOM™ CONTROL

The Vertiv™ iCOM™ control will pull key information from the Lovato ATS, allowing for easy interpretation of the current operation without needing to open the unit's front panel, potentially interrupting operation.

**\*Identification of current power source and power source availability**

\*Available via PA2.06.54.04R or greater



**Power source availability**

- GREEN circle w/ check mark = power source available
- RED circle w/ cross = power source not available

**Power Source A/B utilization**

- ORANGE highlighted & underlined power source title = current power source being utilized.

# AUTOMATIC TRANSFER SWITCH

---

## CONTROL MODULE

### KEY PARAMETERS OF LOVATO ATS, MODELS ATL610 & ATL800

There are multiple key parameters that are factory set by Vertiv to recommended values. Please consult a Vertiv factory technician before making any changes to these parameters.

- Priority power source selection (default = Source 1)
- Switching delay between power sources
  - if secondary power source is present at time of primary failure, delay is up to 11s (default, adjustable via multiple parameters)
  - if secondary power source is **NOT** present at time of primary failure, delay is 10s (default, adjustable) after secondary power source is available
- Unit would be removed from active power source in following conditions:
  - Voltage Limit: If voltage is outside of a set limit for a set period (default = 5s)
    - Min Voltage Limit = 85% (default) of nominal
    - Max Voltage Limit = 115% (default) of nominal
  - Voltage Imbalance: If voltage imbalance (asymmetry) is greater than 15% (default) for a set period (default = 5s)
  - Phase Loss: If a phase falls below 70% (default) of nominal for a set period (default = 0.1s)
  - Frequency Limit: If frequency is outside of a set limit for a set period (default = 3s)
    - Min Freq Limit = 95% (default)
    - Max Frequency Limit = 105% (default)

Please note that not all parameters are applicable to Vertiv equipment operation. Consult a Vertiv factory technician before making any changes to these parameters.

# AUTOMATIC TRANSFER SWITCH

## CONTROL MODULE

### MONITORING FUNCTIONS OF LOVATO ATS, MODELS ATL610 & ATL800

The voltage and frequency information from the ATS can be displayed on the Vertiv™ iCOM™ user interface, as shown in the below image. Further information is available via BMS monitoring through the Vertiv™ iCOM™ Unity Card / Embedded Unity (BACnet MSTP, BACnet IP, Modbus TCP/IP, Modbus RTU, SNMP v2, v3). The items are outlined in the table on the following page.

ATS voltage & frequency summary page

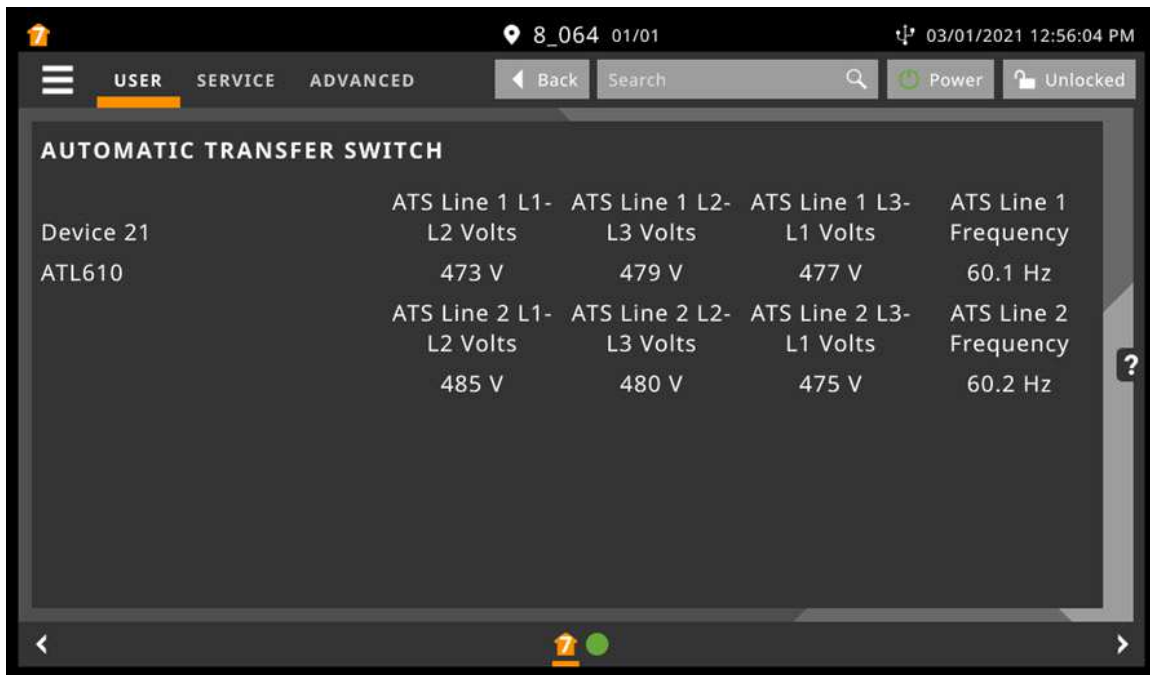

Device 21	ATS Line 1 L1- L2 Volts	ATS Line 1 L2- L3 Volts	ATS Line 1 L3- L1 Volts	ATS Line 1 Frequency
ATL610	473 V	479 V	477 V	60.1 Hz
Device 21	ATS Line 2 L1- L2 Volts	ATS Line 2 L2- L3 Volts	ATS Line 2 L3- L1 Volts	ATS Line 2 Frequency
ATL610	485 V	480 V	475 V	60.2 Hz



# AUTOMATIC TRANSFER SWITCH

## CONTROL MODULE MONITORING POINTS

The below ATS specific points can be monitored through a BMS system. Alarm codes at the ATS panel will not match the BMS alarm but can be cross referenced in this chart. Please note that these points are read only.

Lovato Code (at ATS)	Vertiv Alarm (BMS)	Description
ATS_EvLdTO	ATS Load Not Powered Timeout	Unit has not been powered after preset delay (default = 60s).
ATS1_L1L2	Power Source: L1-L2 voltage	Voltage reading phase L1-L2
ATS1_L2L3	Power Source: L2-L3 voltage	Voltage reading phase L2-L3
ATS1_L3L1	Power Source: L3-L1 voltage	Voltage reading phase L3-L1
ATS1_Freq	Power Source: Line Frequency	Measured frequency, per source.
ATS1_BrkOp	Power Source: Breaker Operation Count	Available to be turned on by customer, would indicate number of operations per source.
ATS1VAIOk	Power Source: All status are okay	All parameters are within limits, per source.
ATS1VLo	Power Source: Voltage Is Too Low	Voltage on active source is below acceptable range.
ATS1VHi	Power Source: Voltage Is Too High	Voltage on active source is above acceptable range.
ATS1VAAsymm	Power Source: Voltages Are Asymmetric	Voltages imbalance alarm
ATS1VPhsLs	Power Source: Voltage Phase Loss	Indicates one of the phases voltage has dropped below 70% nominal.
ATS2VPhsSq	Power Source: Phase Sequence Issue	Indicates the incoming power wasn't wired per the phase sequence configured (L1-L2-L3).
ATS1VFrqLo	Power Source: Frequency Is Too Low	Frequency on active source is below acceptable range.
ATS1VFrqHi	Power Source: Frequency Is Too High	Frequency on active source is above acceptable range.
ATS2BCIsd	Power Source: Breaker is closed	ATS is receiving feedback that the indicated contactor as closed.
ATS2BCCIsd	Power Source: Breaker command status closed	ATS is directing the indicated contactor to close.
ATS1EvBTim	Power Source: Breaker Timeout Issue	The indicated changeover device did not complete the



# AUTOMATIC TRANSFER SWITCH

## CONTROL MODULE CHANGE OVER CIRCUIT SEQUENCE OF OPERATIONS

### Source 1 is out of range

- 1) Source 1 exceeds one or more limits of voltage, frequency, phase, or voltage symmetry.
- 2) A delay timer will begin to count. The amount of time depends on which Source 1 parameter is out of spec, and the value saved in the following parameters. The parameters below are the delays for each condition.

Description	Default	Parameter	
		ATL610	ATL800
Voltage below the minimum limit	5s	P06.03	P09.01.03
Voltage above the maximum limit	5s	P06.06	P09.01.06
Phase failure	0.1s	P06.10	P09.01.10
Voltage exceeds the asymmetry limits	5s	P06.12	P09.01.12
Frequency exceeds the maximum limit	3s	P06.14	P09.01.14
Frequency exceeds the minimum limit	5s	P06.16	P09.01.16

- 3) Once the delay timer is finished, the following events will occur.
  - a. The transfer controller will de-energize Source 1 contactor coil.
  - b. The transfer controller will signal the unit is no longer being powered by Source 1.
  - c. An auxiliary switch NO contact on Source 1's contactor will open, sending a signal to the transfer controller. This signal verifies that the load is not connected to Source 1.
  - d. The NC contacts of the same auxiliary switch will close to allow the coil of the Source 2 contactor to be energized. The Source 2 contactor coil is not energized at this time.
- 4) Once the transfer controller output has opened, a delay timer will begin using the value entered under parameter P05.03 (ATL610) or P07.01.02 (ATL800), default = 6s. **This value should not be decreased without consent from Vertiv.**
- 5) A presence delay is used to determine if Source 2 is a valid source. This delay will start as soon as Source 2 is available. The presence delay is based on the value entered in parameter P07.07 (ATL610) or P09.02.07 (ATL800), default = 10s. If Source 2 is available before Source 1 fails, it is possible that the delay will already be satisfied at the time Source 1 fails. If this is a manual transfer to Source 2 and Source 1 is still available, the presence delay will refer to the value in parameter P07.08 (ATL610) or P09.02.08 (ATL800), default = 60s.
- 6) When the timer in both step 4 and 5 are finished:
  - a. The transfer controller will energize the Source 2 contactor.
  - b. An auxiliary switch NO contact on Source 2's contactor will close, sending a signal to the transfer controller. This signal verifies that the load is connected to Source 2.
  - c. The NC contacts of the same auxiliary switch will open to prevent the coil of Source 1 contactor from energizing.
  - d. The transfer controller will signal the unit is being powered by Source 2.

# AUTOMATIC TRANSFER SWITCH

---

## CONTROL MODULE

### CHANGE OVER CIRCUIT SEQUENCE OF OPERATIONS

#### Transfer back to Source 1 when Source 2 is present

- 1) When Source 1 has reached acceptable levels, a presence delay will start. The presence delay is based on the value entered in parameter P06.08 (ATL610) or P09.01.08 (ATL800), default = 60s.
- 2) Once this timer is finished:
  - a. The transfer controller will de-energize Source 2 contactor coil.
  - b. An auxiliary switch NO contact on Source 2's contactor will open, sending a signal to the transfer controller. This signal verifies that the load is not connected to Source 2.
  - c. The NC contacts of the same auxiliary switch will close to allow the coil of the Source 1 contactor to be energized. The Source 1 contactor coil is not energized at this time.
  - d. The transfer controller will signal the unit is no longer being powered by Source 2.
- 3) A delay timer starts using the value in parameter P05.04 (ATL610) or P07.02.02 (ATL800), default = 6s. **This value should not be decreased without consent from Vertiv.**
- 4) When the timer in step 3 is finished:
  - a. The transfer controller will energize the Source 1 contactor.
  - b. An auxiliary switch NO contact on Source 1's contactor will close, sending a signal the transfer controller. This signal verifies that the load is connected to Source 1.
  - c. The NC contacts of the same auxiliary switch will open to prevent the coil of Source 2 contactor from energizing.
  - d. The transfer controller will signal the unit is being powered by Source 1.

# AUTOMATIC TRANSFER SWITCH

## CONTROL MODULE

### CHANGE OVER CIRCUIT SEQUENCE OF OPERATIONS

#### Source 2 is out of range when unit is powered by Source 2

- 1) Source 2 exceeds one or more limits of voltage, frequency, phase, or voltage symmetry.
- 2) A delay timer will begin to count. The amount of time depends on which Source 2 parameter is out of spec, and the value saved in the following parameters. The parameters below are the delays for each condition.

Description	Default	Parameter	
		ATL610	ATL800
Voltage below the minimum limit	5s	P07.03	P09.02.03
Voltage above the maximum limit	5s	P07.06	P09.02.06
Phase failure	0.1s	P07.10	P09.02.10
Voltage exceeds the asymmetry limits	5s	P07.12	P09.02.12
Frequency exceeds the maximum limit	3s	P07.14	P09.02.14
Frequency exceeds the minimum limit	5s	P07.16	P09.02.16

- 3) Once the delay timer is finished, the following events will occur:
  - a. The transfer controller will de-energize Source 2 contactor coil.
  - b. The transfer controller will signal the unit is no longer being powered by Source 2.
  - c. An auxiliary switch NO contact on Source 2's contactor will open, sending a signal to the transfer controller. This signal verifies that the load is not connected to Source 2.
  - d. The NC contacts of the same auxiliary switch will close to allow the coil of Source 1 contactor to be energized. The Source 1 contactor coil is not energized at this time.
- 4) Once the transfer controller output has opened, a delay timer will begin using the value entered under parameter P05.04 (ATL610) or P07.02.02 (ATL800), default = 6s. This value should not be decreased without consent from Vertiv.
- 5) A presence delay is used to determine if Source 1 is a valid source. This delay will start as soon as Source 1 is available. The presence delay is based on the value entered in parameter P06.07 (ATL610) or P09.01.07 (ATL800), default = 10s. If Source 1 is available before Source 2 fails, it is possible that the delay will already be satisfied at the time Source 2 fails. If this is a manual transfer to Source 1 and Source 2 is still available, the presence delay will refer to the value in parameter P06.08 (ATL610) or P09.01.08 (ATL800), default = 60s.
- 6) When the timer in both steps 4 and 5 are finished:
  - a. The transfer controller will energize the Source 1 contactor.
  - b. An auxiliary switch NO contact on Source 1's contactor will close, sending a signal to the transfer controller. This signal verifies that the load is connected to Source 1.
  - c. The NC contacts of the same auxiliary switch will open to prevent the coil of Source 2 contactor from energizing.
  - d. The transfer controller will signal the unit is being powered by Source 1.

#### Transfer when Source 1 and Source 2 fails

- 1) If both Source 1 and Source 2 fail and are restored, the transfer controller will transfer the load to the preferred Source defined in parameter P05.02 (ATL610) or P06.01.02/P06.02.02 (ATL800), default = 1.

# AUTOMATIC TRANSFER SWITCH

## CONTROL MODULE

### TRANSFER CONTROLLER TERMINAL LABELS – ATL610

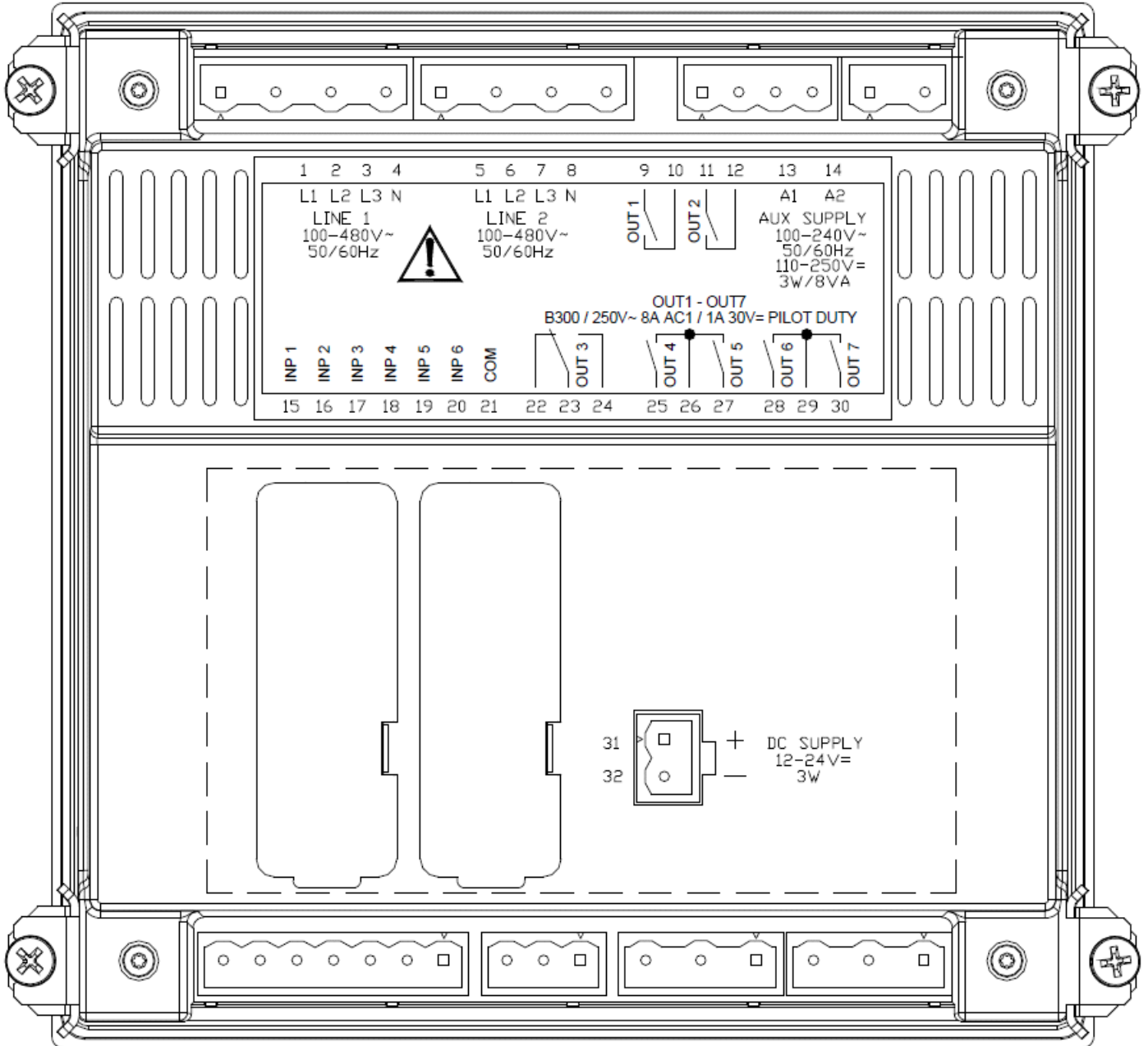



# AUTOMATIC TRANSFER SWITCH

## CONTROL MODULE

### TRANSFER CONTROLLER TERMINAL LABELS – ATL800

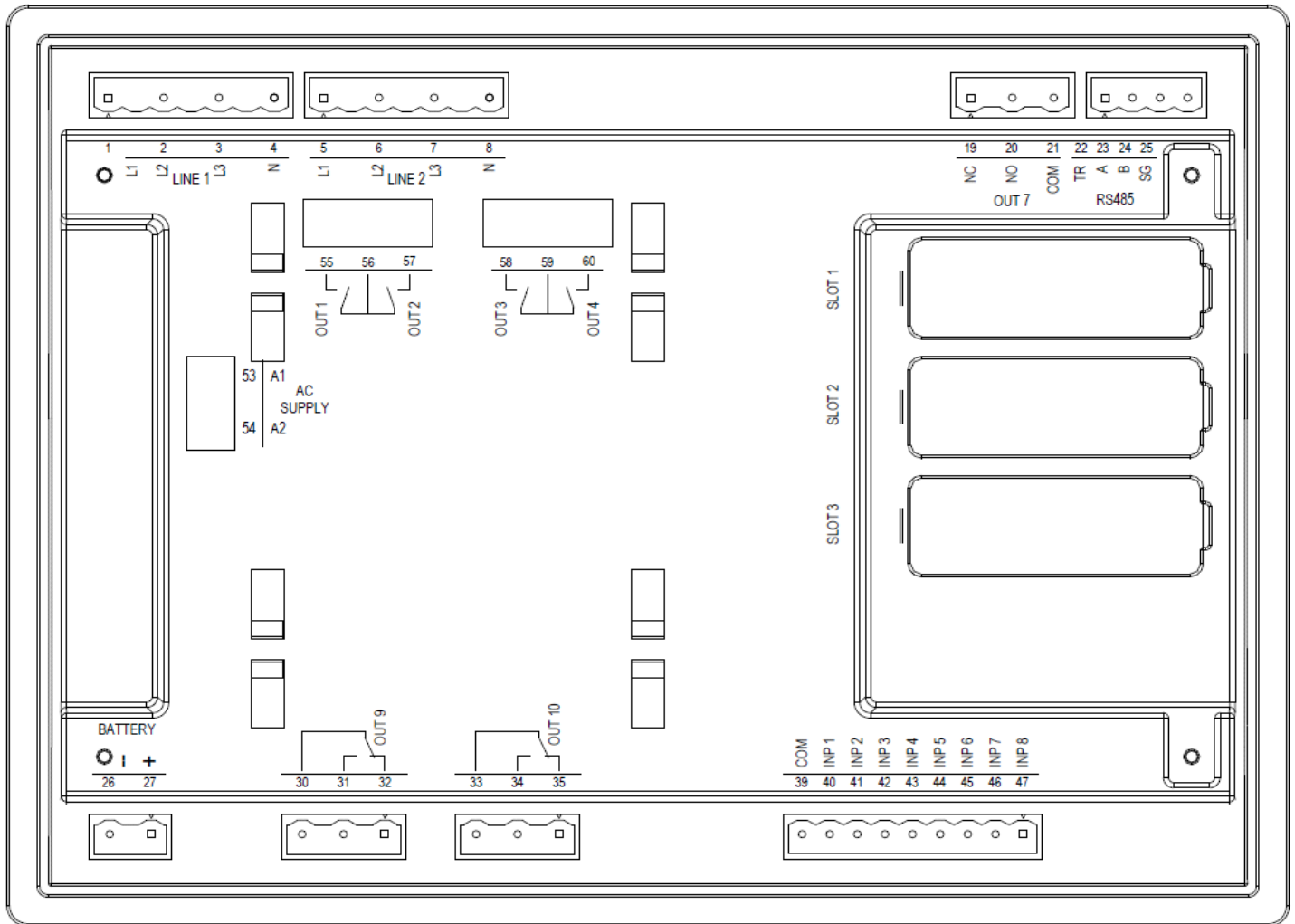

## THD MITIGATION CW305, 375, 415

IEEE Std 519-2014 defines the maximum voltage distortion limits allowed to be reflected onto the utility distribution system at the point of common coupling (PCC). It is a guideline meant to minimize the effects of electrical pollution created by one utility customer from affecting a different customer.

The guideline requires total voltage harmonic distortion (THD) conform to the limits shown in Table 1.

**Table 1 - Voltage distortion limits**

Bus voltage V at PCC	Individual Harmonic (%)	Total harmonic distortion THD (%)
$V \leq 1.0 \text{ kV}$	5.0	8.0
$1 \text{ kV} < V \leq 69 \text{ kV}$	3.0	5.0
$69 \text{ kV} < V \leq 161 \text{ kV}$	1.5	2.5
$161 \text{ kV} < V$	1.0	1.5 <sup>a</sup>

<sup>a</sup>High-voltage systems can have up to 2.0% THD where the cause is an HVDC terminal whose effects will have attenuated at points in the network where future users may be connected.

The individual harmonic current distortion and total current demand distortion (TDD) conform to the limits shown in Table 2.

**Table 2 - Current distortion limits for systems rated 120 V through 69 kV**

Maximum harmonic current distortion in percent of $I_L$						
Individual harmonic order (odd harmonics) <sup>a,b</sup>						
$I_{sc} / I_L$	$3 \leq h < 11$	$11 \leq h < 17$	$17 \leq h < 23$	$23 \leq h < 135$	$35 \leq h < 50$	TDD
$< 20^c$	4.0	2.0	1.5	0.6	0.3	5.0
$20 < 50$	7.0	3.5	2.5	1.0	0.5	8.0
$50 < 100$	10.0	4.5	4.0	1.5	0.7	12.0
$100 < 1000$	12.0	5.5	5.0	2.0	1.0	15.0
$> 1000$	15.0	7.0	6.0	2.5	1.4	20.0

<sup>a</sup>Even harmonics are limited to 25% of the odd harmonic limits above.

<sup>b</sup>Current distortions that result in a dc offset, e.g., half-wave converters, are not allowed.

<sup>c</sup>All power generation equipment is limited to these values of current distortion, regardless of actual  $I_{sc} / I_L$ .

where

$I_{sc}$  = maximum short-circuit current at PCC

$I_L$  = maximum demand load current (fundamental frequency component)  
at the PCC under normal load operating conditions

It is **NOT** a guideline for individual connected loads, but a guideline for a total building or plant. Many apply the voltage distortion criteria to all substations, and apply the current distortion criteria exclusively to the utility metering point.

Typically, if the variable speed fan load is less than 10% of the current capacity at the point of common coupling (PCC), your installation will meet IEEE-519 guidelines. In this case you should have no interference issues with other electrical equipment. Typically, the worst case PCC is the emergency backup generator plant but could be the transformer which powers the cooling load. If the PCC is a UPS unit, consult your UPS supplier for recommendations. For customers who have variable speed loads that exceed this rule of thumb, it may be necessary to minimize the harmonic impact these variable speed loads have on the system voltage. In these instances, an undesirable effect is a difficulty in switching from generator supply back to utility supply. The purpose of the Liebert® CW THD mitigation device is to cancel current harmonics generated by the variable frequency drive. This device will not improve harmonics caused by other systems on the power network.



# LIEBERT® CW

## THD MITIGATION CW305, 375, 415

Below are the Total Voltage Distortion levels as measured on a single CW415 unit. This data is typical of what can be expected in the field on CW305, CW375 and CW415 units. Values may vary depending on operating conditions.

Typical Total Voltage Distortion for CW305, CW375 and CW415 at 460 Volts:

Voltage Harmonic List — 100% Fan Speed

Without Mitigation Device						
Order	L1		L2		L3	
	Volts	% Distortion	Volts	% Distortion	Volts	% Distortion
1	481.65		481.41		481.68	
5	1.49	0.31%	1.65	0.34%	1.47	0.30%
7	0.75	0.16%	0.79	0.16%	0.74	0.15%
11	0.60	0.12%	0.71	0.15%	0.84	0.17%
13	0.51	0.11%	0.29	0.11%	0.48	0.10%
17	0.61	0.13%	0.57	0.12%	0.71	0.15%
Total THD (%)	1.18%		0.95%		1.26%	
With Mitigation Device						
Order	L1		L2		L3	
	Volts	% Distortion	Volts	% Distortion	Volts	% Distortion
1	481.33		481.33		481.49	
5	0.29	0.06%	0.21	0.05%	0.30	0.06%
7	0.18	0.04%	0.11	0.02%	0.17	0.04%
11	0.52	0.11%	0.47	0.10%	0.50	0.10%
13	0.11	0.02%	0.07	0.01%	0.06	0.01%
17	0.11	0.02%	0.15	0.03%	0.14	0.03%
Total THD (%)	0.83%		0.43%		0.85%	

Voltage Harmonic List — 50% Fan Speed

Without Mitigation Device						
Order	L1		L2		L3	
	Volts	% Distortion	Volts	% Distortion	Volts	% Distortion
1	483.89		483.83		483.60	
5	6.11	1.26%	5.26	1.09%	4.40	0.91%
7	1.78	0.37%	1.55	0.32%	1.46	0.30%
11	0.11	0.02%	0.16	0.03%	0.17	0.03%
13	0.24	0.05%	0.17	0.03%	0.11	0.02%
17	0.16	0.03%	0.19	0.04%	0.13	0.03%
Total THD (%)	1.63%		1.45%		1.45%	
With Mitigation Device						
Order	L1		L2		L3	
	Volts	% Distortion	Volts	% Distortion	Volts	% Distortion
1	484.02		483.96		483.73	
5	2.71	0.56%	1.89	0.39%	2.71	0.56%
7	0.68	0.14%	0.68	0.14%	0.63	0.13%
11	0.32	0.07%	0.38	0.08%	0.42	0.09%
13	0.17	0.04%	0.17	0.03%	0.17	0.04%
17	0.07	0.02%	0.08	0.02%	0.08	0.02%
Total THD (%)	1.10%		0.86%		1.11%	



# LIEBERT® CW

## THD MITIGATION CW305, 375, 415

Below are the Total Current Distortion levels as measured on a single CW415 unit. This data is typical of what can be expected in the field on CW305, CW375 and CW415 units. Values may vary depending on operating conditions.

Typical Total Current Distortion for CW305, CW375 and CW415 at 460 Volts:

Current Harmonic List — 100% Fan Speed

Without Mitigation Device						
Order	L1		L2		L3	
	amps	% Distortion	amps	% Distortion	amps	% Distortion
1	44.85		44.26		43.74	
5	15.58	34.74%	15.29	34.54%	15.91	36.36%
7	5.65	12.59%	5.45	12.32%	5.58	12.75%
11	3.28	7.30%	3.26	7.36%	3.44	7.86%
13	1.57	3.51%	1.53	3.46%	1.47	3.37%
17	1.48	3.29%	1.43	3.24%	1.58	3.62%
Total THD (%)	39.37%		38.31%		41.58%	
With Mitigation Device						
Order	L1		L2		L3	
	amps	% Distortion	amps	% Distortion	amps	% Distortion
1	46.49		45.70		45.69	
5	0.91	1.95%	0.71	1.55%	1.01	2.20%
7	0.83	1.79%	0.68	1.50%	0.76	1.67%
11	0.88	1.90%	0.87	1.91%	0.95	2.08%
13	0.63	1.35%	0.56	1.22%	0.56	1.22%
17	0.25	0.54%	0.27	0.59%	0.29	0.65%
Total THD (%)	6.76%		6.49%		7.37%	

Current Harmonic List — 50% Fan Speed

Without Mitigation Device						
Order	L1		L2		L3	
	amps	% Distortion	amps	% Distortion	amps	% Distortion
1	9.76		9.10		8.20	
5	6.72	68.85%	6.82	74.94%	5.90	72.03%
7	4.96	50.81%	4.28	47.04%	4.42	53.95%
11	1.13	11.61%	1.43	15.75%	1.33	16.18%
13	0.77	7.94%	0.34	3.77%	0.70	8.50%
17	0.48	4.96%	0.65	7.15%	0.48	5.89%
Total THD (%)	89.96%		93.56%		94.88%	
With Mitigation Device						
Order	L1		L2		L3	
	amps	% Distortion	amps	% Distortion	amps	% Distortion
1	14.09		13.97		14.30	
5	0.35	2.52%	0.18	1.29%	0.38	2.67%
7	0.66	4.66%	0.57	4.11%	0.65	4.55%
11	0.17	1.18%	0.22	1.56%	0.19	1.36%
13	0.19	1.38%	0.15	1.08%	0.17	1.16%
17	0.08	0.58%	0.11	0.81%	0.11	0.75%
Total THD (%)	20.82%		20.09%		22.68%	

NOTE: Values shown at 50% fan speed are for reference only. At low demand, THD values will have a lower impact on the system than at full load.

## UNIT TO UNIT NETWORK CONNECTIONS

LIEBERT® CW, LIEBERT® CWA, LIEBERT® DS, LIEBERT® DSE,  
LIEBERT® PDX, LIEBERT® PCW

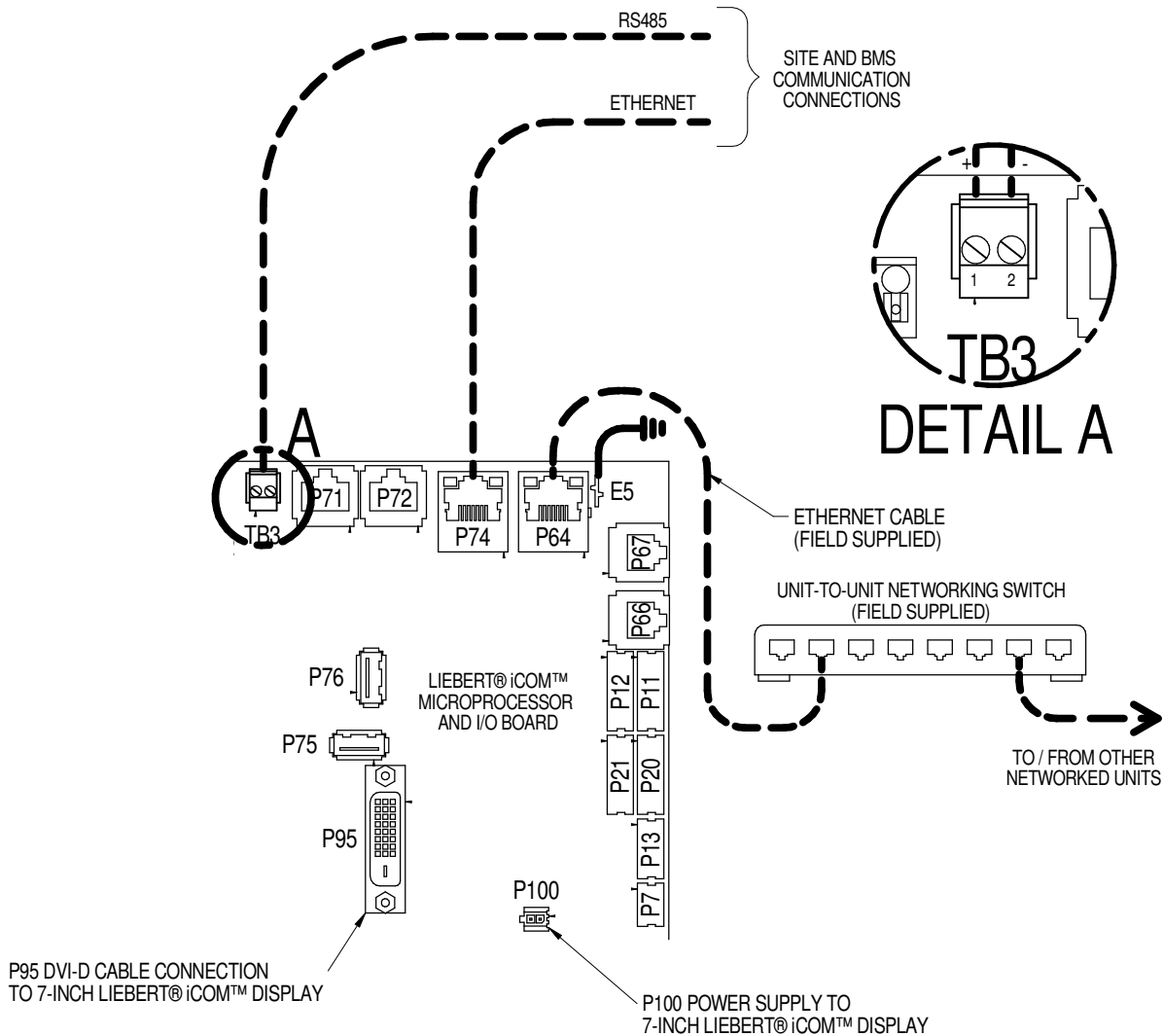

## UNIT TO UNIT NETWORK CONNECTIONS

LIEBERT® CW, LIEBERT® CWA, LIEBERT® DS, LIEBERT® DSE,  
LIEBERT® PDX, LIEBERT® PCW

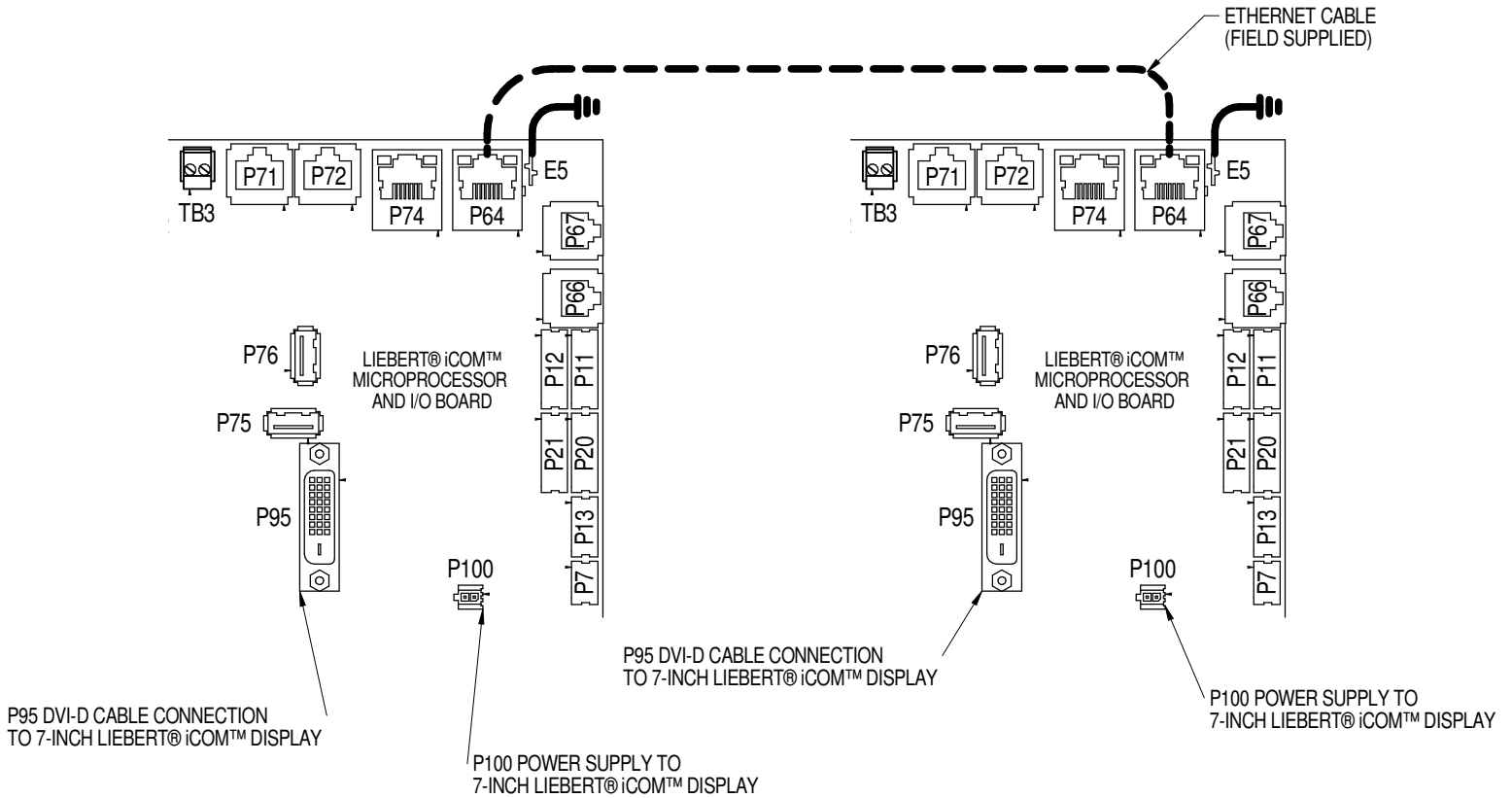

**NOTE\*** For dual-unit network configurations only



# LIEBERT® CW

## SEISMIC APPLICATION ASSUMPTIONS AND REQUIREMENTS CW305/375/415 HORIZONTAL & BOTTOM DISCHARGE UNIT

Vertiv has conducted analytical modeling of the **Liebert® CW CW305/375/415** product to provide an option for those systems requiring seismic certification of compliance. This certification goes beyond the equipment's ability to withstand the seismic forces: the IBC (International Building Code) and ASCE (American Society of Civil Engineers) system approach includes the equipment, equipment anchorage, and the connections to the equipment [power, piping, and ducting].

### Certification Criteria

The **Liebert® CW CW305/375/415** certification is based on a maximum mapped, maximum considered earthquake spectral response acceleration value, **S<sub>s</sub>, of 3.75g** adjusted by the soil site coefficient to Soil Site Class D as the default when the site soil properties or final equipment installation location is not known.

The certification maximum spectral response coefficient is **S<sub>ds</sub> value of 2.50g** including Soil Class and Seismic Use group corrections. Soil Classes A, B, C, D, and E, and Seismic Design Categories A, B, C, D, E, and F are all covered under this certification, limited by the S<sub>ds</sub> value stated above. Structural analysis has been conducted to demonstrate that the equipment meets performance objectives required for a component importance factor (I<sub>p</sub>) of 1.0. Specifically, structural integrity is demonstrated such as to not pose a life safety hazard. Although this unit is not certified for the performance objective associated with an I<sub>p</sub>=1.5 (continued functionality after a seismic event), the analyses of non-active components has been conducted with increased seismic demands associated with I<sub>p</sub>=1.5 to ensure a seismically robust unit (structural integrity).

A Liebert CW CW305/375/415, as described above, is approved for seismic application as a system when properly installed in the following configurations:

- Liebert® CW CW305/375/415 unit, with factory-installed seismic option, attached directly to a housekeeping pad using the anchoring system defined in this document.
- Liebert® CW CW305/375/415 unit, with factory-installed seismic option, installed on a Vertiv-supplied, IBC-certified floor stand and attached securely to the building structure.  
The floor stand and mounting system must be Vertiv catalog items, purchased from Vertiv.  
The system must be anchored as specified in this document.
- The certification excludes all non-Vertiv supplied accessories, including but not limited to floor stands, and isolators.

Certification	IBC	
Internal Bracing Option	Yes	
Floorstand attachment	Welded	
Unit	S <sub>ds</sub>	I <sub>p</sub>
CW305/375/415	2.5	1.0

## SEISMIC APPLICATION ASSUMPTIONS AND REQUIREMENTS CW305/375/415 HORIZONTAL & BOTTOM DISCHARGE UNIT

### Requirements for Anchorage

#### Anchors

1. Mounting requirement details such as brand, type, embedment depth, edge spacing, anchor spacing, concrete strength, wall bracing, and special inspection must be outlined and approved by the project Structural Engineer of Record.

#### Anchorage Surface

2. Structural floors and housekeeping pads must also be seismically designed and approved by the project Structural Engineer of Record to withstand the seismic anchor loads as defined on the installation drawings. The installing contractor is responsible for the proper installation of all anchors and mounting hardware, observing the mounting requirement details outlined by the Engineer of Record. Contact the Manufacturer's Representative if a detailed Seismic Installation Calculation Package is required.

### Unit Field Connections



#### Piping Field Connections:

All units, either rigidly mounted or mounted on vibration isolators, shall be attached to the piping system using flexible loops designed for seismic movement.

Flexible loops shall be capable of movement in the three axes and must completely isolate the equipment from the piping.

The loops shall be suitable for an operating pressure and temperature of the system, refer to Vertiv installation instructions.

This includes 1/4" copper humidifier supply, condensate drainage, and chilled water supply and return. Follow manufacturer's installation instructions for proper seismic application of flexible looping.

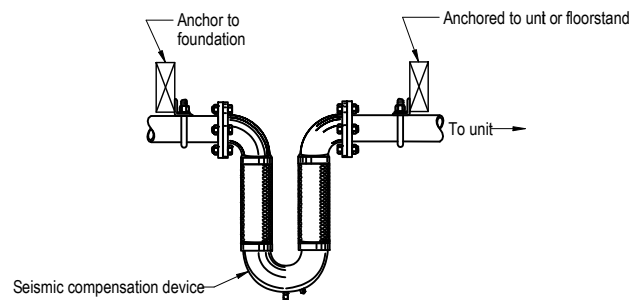

#### Piping Field Connections

4. Electrical Connections:  
Must have adequate flexibility for seismic movement.  
Electrical wiring, conduit, and/or other connections to the equipment is the responsibility of others.  
Data and recommendations are supplied here and in the unit installation supplement for seismic installation.
5. Duct Considerations:  
Seismic compensation shall be field supplied between the field supplied duct work and unit.  
Flexible joints shall be capable of movement in the three axes and must completely isolate the equipment from the duct work. Follow duct manufacturer's installation instructions for proper seismic application of flexible ducts.

## DIMENSIONAL DATA

### SEISMIC ANCHORAGE FOR CW305/375/415 HORIZONTAL DISCHARGE UNITS

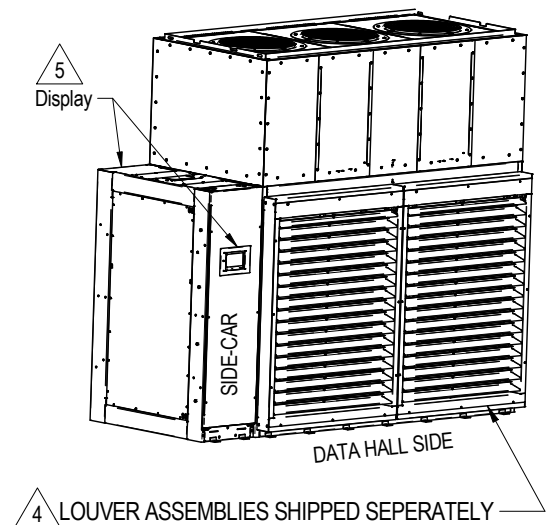
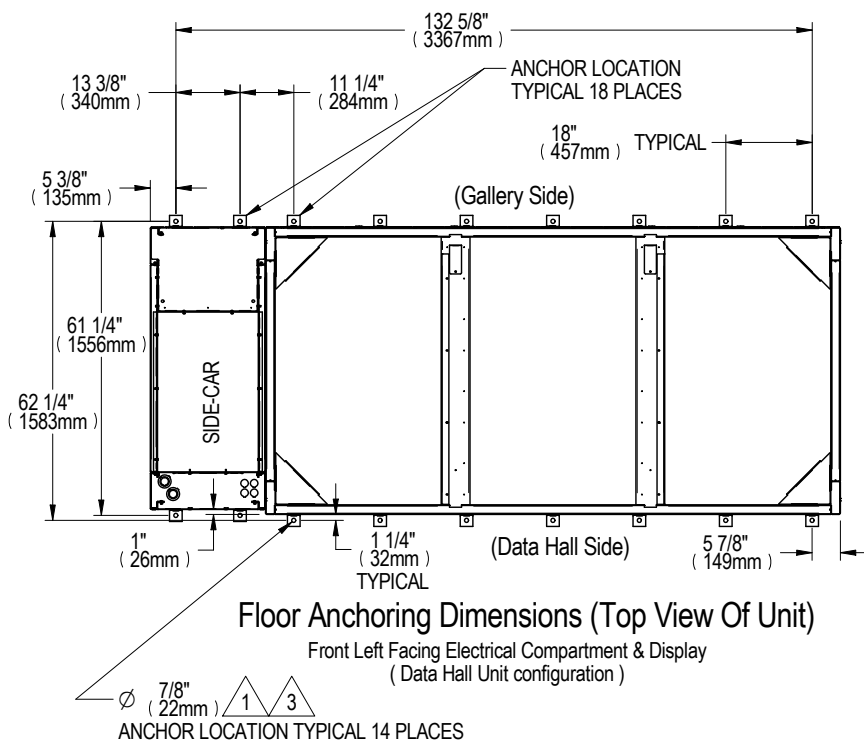
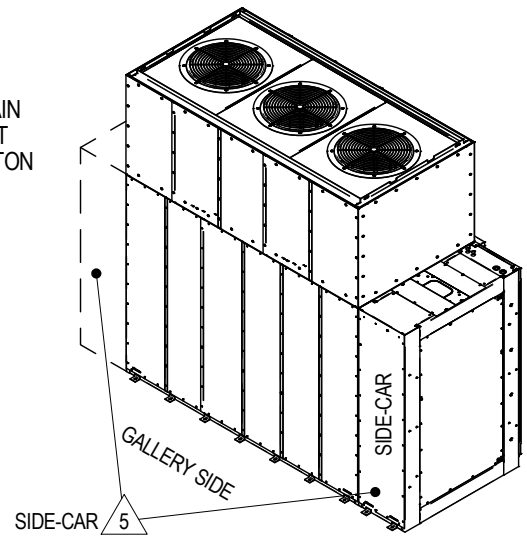
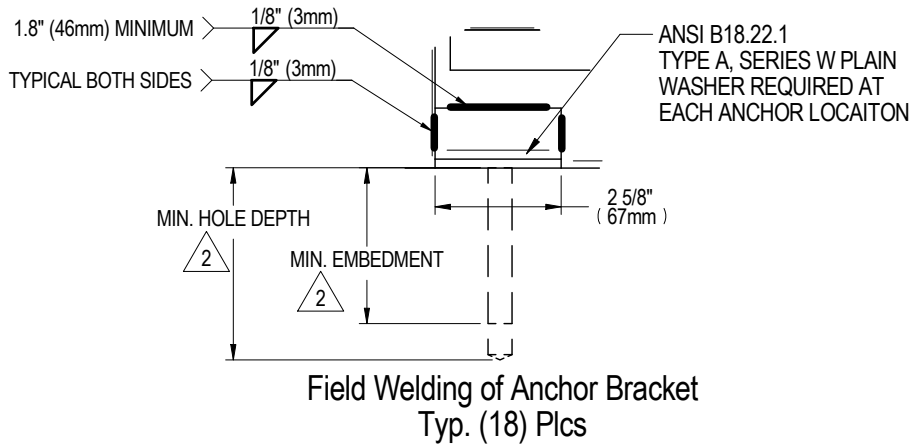

**Front Left Facing  
Electrical Compartment & Display  
Data Hall Unit configuration**

Notes:

1. Anchor Bolt sized per Engineer of Record.
2. Specified by Engineer of Record.
3. If the Engineer of Record specifies an anchor diameter less than 3/4", a washer should be welded over the 7/8" hole to accomdate the smaller diameter anchor.
4. Louvers must be removed to access floor anchors on Data Hall Side.
5. Unit shown in views is: Front, "Left Facing" Side-Car, with Electrical Compartment / Display on the Data Hall side of unit. Views are typical of all unit configurigurations. Side-Car can also be configured to be "Right Facing". Electrical Compartment & Display can also configured to be on Gallery side of Side-Car / unit.

## DIMENSIONAL DATA

### SEISMIC ANCHORAGE RIGID FLOORSTAND FOR CW305/375/415 HORIZONTAL & BOTTOM DISCHARGE UNIT

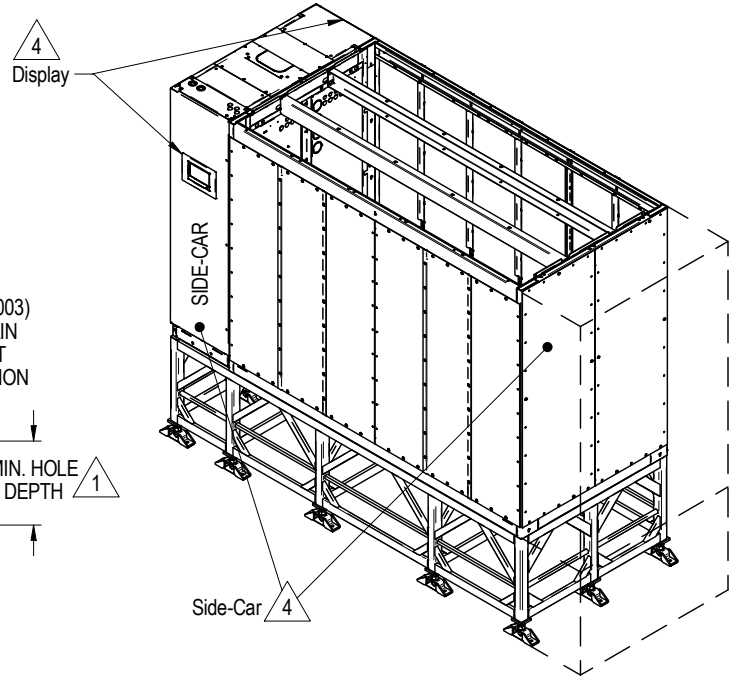
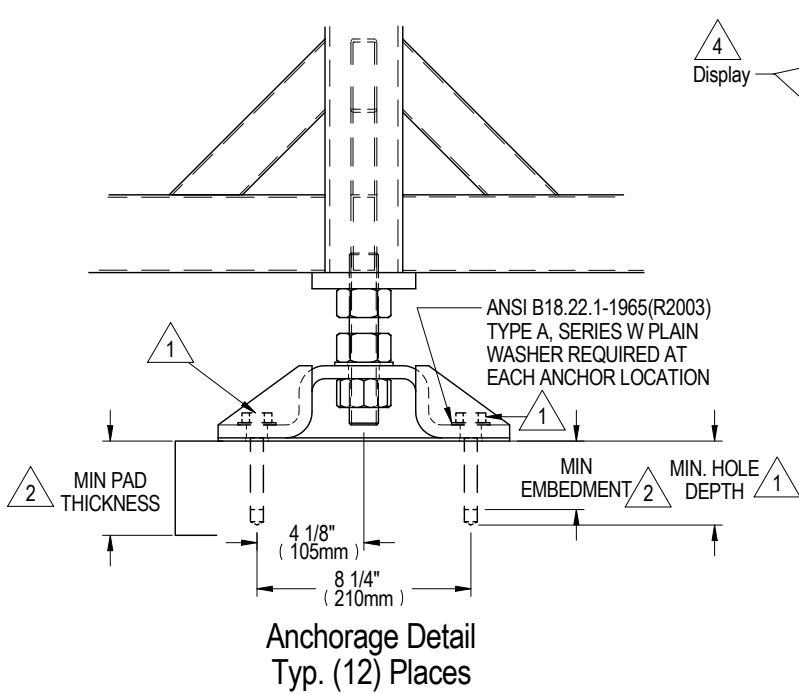

**Front Left Facing Electrical Compartment & Display  
Data Hall Unit configuration**

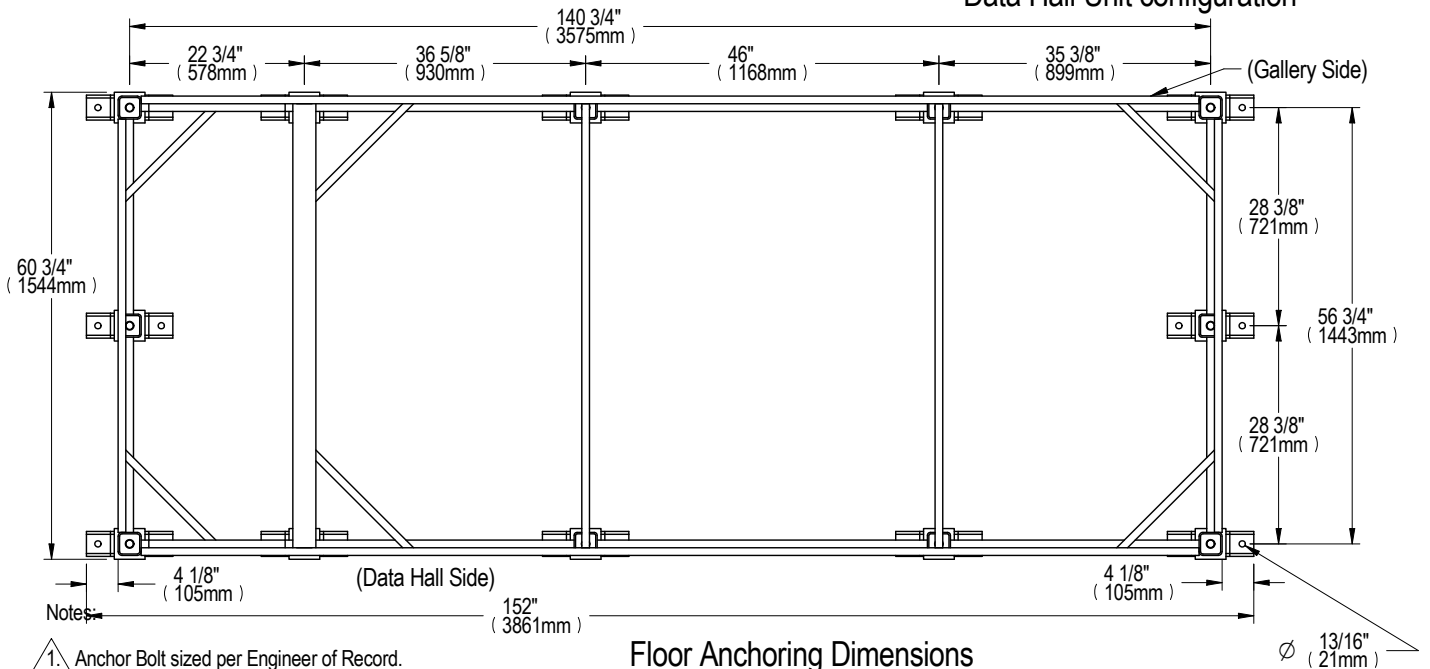

1. Anchor Bolt sized per Engineer of Record.

2. Specified by Engineer of Record.

3. Floorstand feet can be oriented in any direction.

4. Unit shown in views is: Front, "Left Facing" Side-Car, with Electrical Compartment / Display on the Data Hall side of unit. Views are typical of all unit configurations. Side-Car can also be configured to be "Right Facing". Electrical Compartment & Display can also be configured to be on Gallery side of Side-Car / unit.

**DIMENSIONAL DATA**  
**SEISMIC ANCHORAGE RIGID FLOORSTAND FOR CW305/375/415**  
**HORIZONTAL & BOTTOM DISCHARGE UNIT**

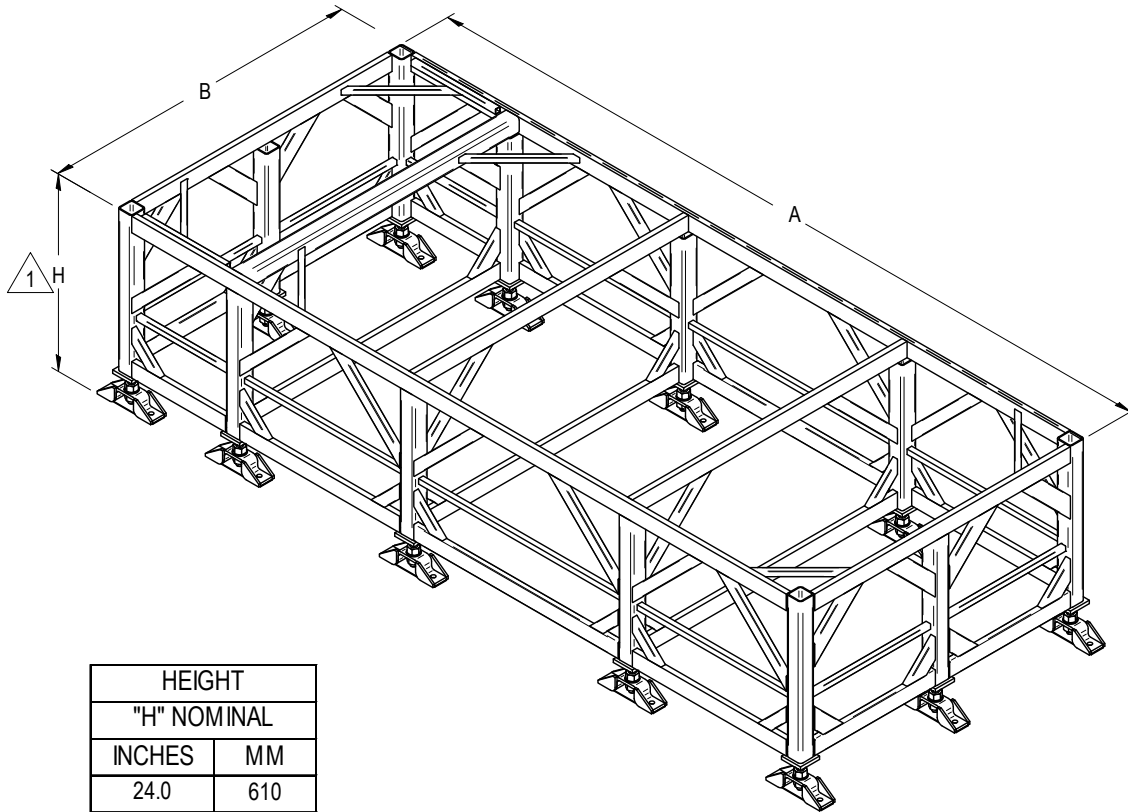

HEIGHT	
"H" NOMINAL	
INCHES	MM
24.0	610
30.0	762
36.0	914
42.0	1067
48.0	1219

MODEL	A		B	
	INCHES	MM	INCHES	MM
CW305/375/415	143.8	3651	59.8	1519

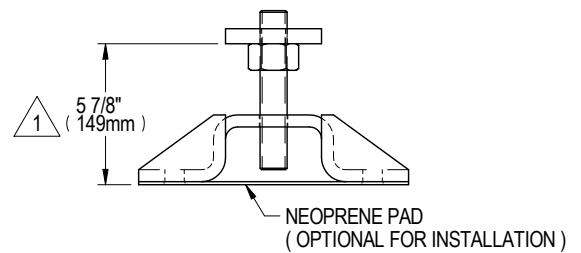

**Foot Detail**

1. Foot provides  $\pm 0.25"$  (6mm) adjustment from nominal height "H".
2. Floorstand is used on CW305/375/415 units with both Bottom Discharge or Horizontal Discharge configurations.
3. Floorstand feet can be oriented in any direction.

## DIMENSIONAL DATA

### SEISMIC ANCHORAGE RIGID FLOORSTAND FOR CW305/375/415 HORIZONTAL & BOTTOM DISCHARGE UNIT

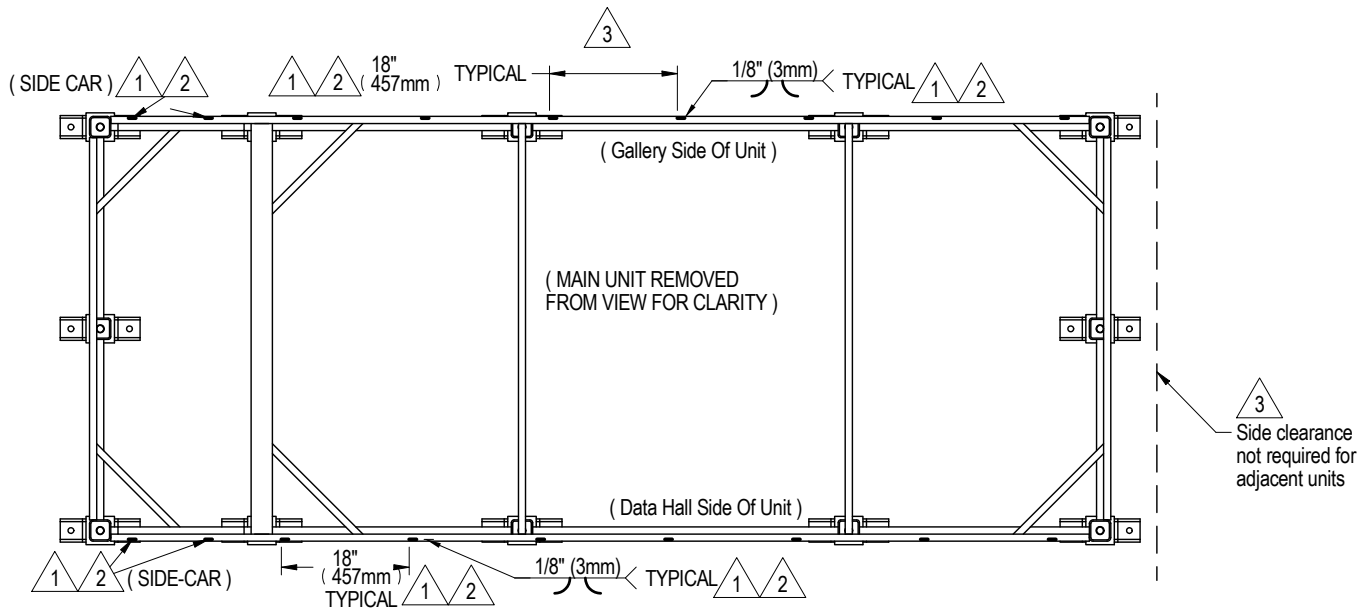

**TOP VIEW OF FLOORSTAND**

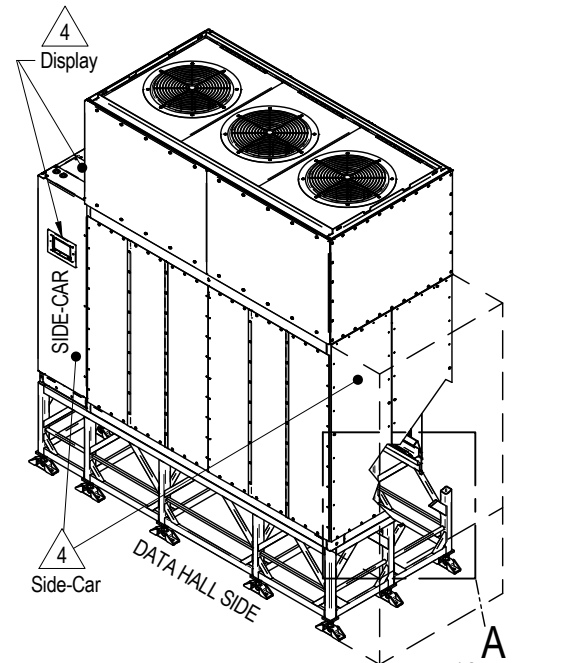
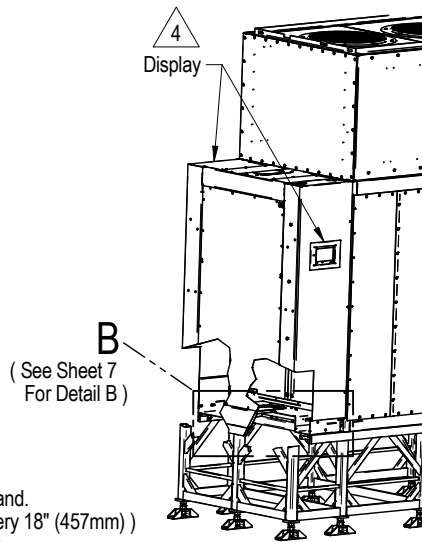

**Front Left Facing  
Electrical Compartment & Display  
(Data Hall Unit configuration)**

**NOTES:**

1. For welded connection of unit to floorstand:  
Front and rear sides of unit to be welded to floorstand.  
Apply 1/8" (3mm) by 1" (25.4mm) long welds every 18" (457mm) maximum to interior or external face of long sides.  
Side-Car should include (2) welds in weld pattern.
2. In lieu of welds, screwed clips (3" wide 1/8" thick) can be used.  
Screwed clips to be attached via (6) 1/4" self-threading screws to unit and (6) 1/4" self-threading screws to floorstand per each screwed clip.
3. For units that will be installed against a wall:  
Complete attachment of unit to floorstand before moving into place.  
Welds or screwed clips may also be applied internally to the floorstand.  
For internal weld refer to Detail A
4. Unit shown in views is: Front, "Left Facing" Side-Car, with Electrical Compartment / Display on the Data Hall side of unit. Views are typical of all unit configurations.  
Side-Car can also be configured to be "Right Facing". Electrical Compartment & Display can also be configured to be on Gallery side of Side-Car / unit.

## DIMENSIONAL DATA

### SEISMIC ANCHORAGE RIGID FLOORSTAND FOR CW305/375/415

### HORIZONTAL & BOTTOM DISCHARGE UNIT

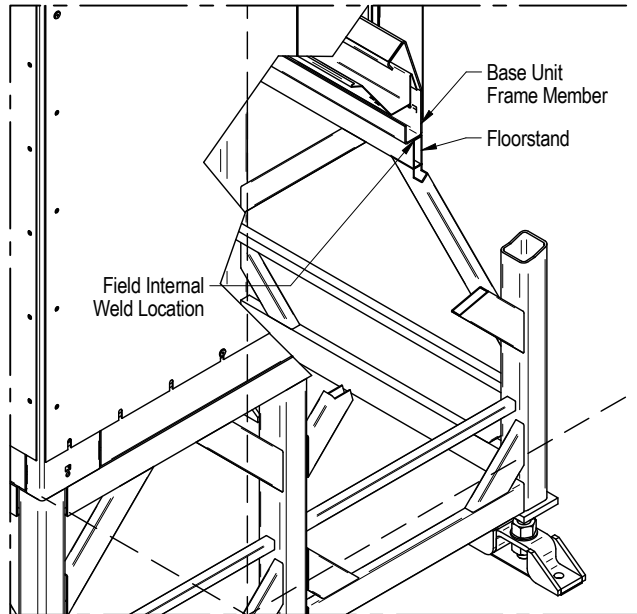

**DETAIL A**  
( FROM SHEET 6 )  
( INTERNAL WELD )

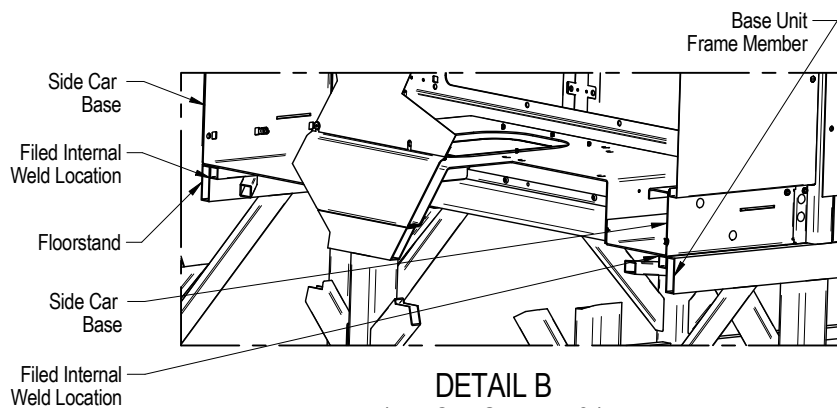

**DETAIL B**  
( FROM SHEET 6 )  
( INTERNAL WELD ( SIDE CAR ) )

### **Connect with Vertiv on Social Media**



<https://www.facebook.com/vertiv/>



<https://www.instagram.com/vertiv/>



<https://www.linkedin.com/company/vertiv/>



<https://www.x.com/Vertiv/>



---

Vertiv.com | Vertiv Headquarters, 1050 Dearborn Drive, Columbus, OH, 43085, USA

© 2026 Vertiv Group Corp. All rights reserved. Vertiv™ and the Vertiv logo are trademarks or registered trademarks of Vertiv Group Corp. All other names and logos referred to are trade names, trademarks or registered trademarks of their respective owners. While every precaution has been taken to ensure accuracy and completeness here, Vertiv Group Corp. assumes no responsibility, and disclaims all liability, for damages resulting from use of this information or for any errors or omissions. Specifications, rebates and other promotional offers are subject to change at Vertiv's sole discretion upon notice.

SL-70374\_REV3\_04-26