



# NetSure™ 8100 Series -48 VDC Power Distribution System

## Installation and User Manual

Specification Number: 582140600

Model Number: 8100DB

The information contained in this document is subject to change without notice and may not be suitable for all applications. While every precaution has been taken to ensure the accuracy and completeness of this document, Vertiv assumes no responsibility and disclaims all liability for damages resulting from use of this information or for any errors or omissions. Refer to other local practices or building codes as applicable for the correct methods, tools, and materials to be used in performing procedures not specifically described in this document.

The products covered by this instruction manual are manufactured and/or sold by Vertiv. This document is the property of Vertiv and contains confidential and proprietary information owned by Vertiv. Any copying, use or disclosure of it without the written permission of Vertiv is strictly prohibited.

Names of companies and products are trademarks or registered trademarks of the respective companies. Any questions regarding usage of trademark names should be directed to the original manufacturer.

### **Technical Support Site**

If you encounter any installation or operational issues with your product, check the pertinent section of this manual to see if the issue can be resolved by following outlined procedures.

Visit <https://www.vertiv.com/en-us/support/> for additional assistance.

## TABLE OF CONTENTS

<b>Admonishments Used in this Document</b> .....	<b>v</b>
<b>Important Safety Instructions</b> .....	<b>vi</b>
Safety Admonishments Definitions.....	vi
Safety and Regulatory Statements.....	vi
Déclarations de Sécurité et de Réglementation.....	vi
<b>1 Customer Documentation Package</b> .....	<b>1</b>
<b>2 System Description</b> .....	<b>2</b>
<b>3 Installation Acceptance Checklist</b> .....	<b>3</b>
<b>4 Physically Installing the System</b> .....	<b>4</b>
4.1 General Requirements.....	4
4.2 Physical Security.....	4
4.3 Installing the Bays.....	5
4.4 Installing Distribution Panel Paralleling Bars (if furnished).....	7
4.5 Installing the Internal Ground/Return Busbar Paralleling Bars List 39 (8-Panel Bay Only) (if furnished).....	8
4.6 Field Installing Bay Input Feed and Shunt Assembly List 43.....	9
<b>5 Making Switch and Jumper Settings</b> .....	<b>15</b>
5.1 Circuit Cards with Jumpers and/or Switches Locations.....	15
5.2 Switch Settings on IB2 Interface Board.....	16
5.3 Switch Settings on SM-DUE.....	17
5.4 Jumper Settings on SM-DUE.....	19
5.5 Switch Settings on SM-DUH2.....	21
<b>6 Making Electrical Connections</b> .....	<b>23</b>
6.1 Important Safety Instructions.....	23
6.2 Wiring Considerations.....	23
6.3 Bay Overall Connections Diagram.....	24
6.4 Bay Frame Grounding Connection.....	25
6.5 External Alarm, Reference, Monitoring, and Control Connections.....	26
6.6 System Ethernet Port Connections.....	32
6.7 Installing and Wiring to an Optional Transient Voltage Surge Suppressor (TVSS) Device.....	33
6.8 Input/Output Cable Routing and Cable Management.....	35
6.9 Load Distribution Connections.....	39
6.10 DC Input Connections.....	47
<b>7 Installing Circuit Breakers and Fuses</b> .....	<b>52</b>
<b>8 Initially Starting, Configuring, and Checking System Operation</b> .....	<b>56</b>
8.1 Important Safety Instructions.....	56
8.2 Initial Startup Preparation.....	56
8.3 Initially Starting the System.....	56
8.4 Monitor Unit Initialization.....	56
8.5 Verifying and Setting the Monitor Unit as Required for Your Application.....	58
8.6 Checking System Status.....	60
8.7 Final Steps.....	61
<b>9 Operating the System</b> .....	<b>62</b>

9.1 Monitor Unit.....62

9.2 Local Controls and Indicators.....62

**10 Maintenance ..... 67**

10.1 Important Safety Instructions.....67

10.2 Routine Maintenance.....67

10.3 System Expansion.....67

**11 Troubleshooting and Repair ..... 72**

11.1 Important Safety Instructions.....72

11.2 Contact Information.....72

11.3 Monitor Unit.....72

11.4 System Troubleshooting Information .....72

11.5 Replacement Information.....72

11.6 Replacement Procedures.....72

## Admonishments Used in this Document



**DANGER!** Warns of a hazard the reader *will* be exposed to that will *likely* result in death or serious injury if not avoided. (ANSI, OSHA)



**WARNING!** Warns of a potential hazard the reader *may* be exposed to that *could* result in death or serious injury if not avoided. This admonition is not used for situations that pose a risk only to equipment, software, data, or service. (ANSI)



**CAUTION!** Warns of a potential hazard the reader *may* be exposed to that *could* result in minor or moderate injury if not avoided. (ANSI, OSHA) This admonition is not used for situations that pose a risk only to equipment, data, or service, even if such use appears to be permitted in some of the applicable standards. (OSHA)



**ALERT!** Alerts the reader to an action that *must be avoided* in order to protect equipment, software, data, or service. (ISO)



**ALERT!** Alerts the reader to an action that *must be performed* in order to prevent equipment damage, software corruption, data loss, or service interruption. (ISO)



**FIRE SAFETY!** Informs the reader of fire safety information, reminders, precautions, or policies, or of the locations of fire-fighting and fire-safety equipment. (ISO)



**SAFETY!** Informs the reader of general safety information, reminders, precautions, or policies not related to a particular source of hazard or to fire safety. (ISO, ANSI, OSHA)

## **Important Safety Instructions**

### **Safety Admonishments Definitions**

Definitions of the safety admonishments used in this document are listed under “Admonishments Used in this Document” on page v.

### **Safety and Regulatory Statements**

Refer to Section 4154 (provided with your customer documentation) for Safety and Regulatory Statements.

### **Déclarations de Sécurité et de Réglementation**

Reportez-vous à la Section 4154 (fourni avec les documents de votre client) pour les déclarations de sécurité et de réglementation.

# 1 Customer Documentation Package

This document (UM582140600) provides *Installation and User Instructions* for Vertiv™ NetSure™ -48 VDC Power Distribution System Model 8100DB, Spec. No. 582140600.

The complete Customer Documentation Package consists of...

## **NetSure™ -48 VDC Power Distribution System Installation and User Manual**

- Installation and User Instructions: UM582140600
- System Application Guide: SAG582140600
- Engineering Drawings
- Contact Information Page: Section 4154

## **Vertiv™ NetSure™ Monitor Unit User Manual**

- Monitor Unit User Instructions: UM1M832DNA

## **Configuration Drawing**

- Available is a configuration drawing (C-drawing).

For factory settings of all configurable parameters, refer to the configuration drawing (C-drawing) supplied with your system.

## 2 System Description

### -48 VDC Power Distribution System

The Vertiv™ NetSure™ 8100DB DC Power Distribution System is a -48 VDC Battery Distribution Fuse / Circuit Breaker Bay (BDF/CBB).

- The NetSure™ 8100DB can be ordered as an 8-distribution panel or 6-distribution panel bay (4 or 3 panels per side).
- Each distribution panel can be configured for separate inputs giving you an 8-load or 6-load bay, or the panels per side can be paralleled to allow one to four feeds per side giving you a 2-load bay (may use the optional internal ground/return bar). Other configurations include an 8-panel bay with 4-loads and two loads, and a 6-panel bay with 4-loads (paralleling the top two panels **or** paralleling the bottom two panels per side).
- Each bay can be equipped with an optional “full bay length” internal ground/return bar (per side). Another option includes replacing one (8- and 6-panel bays) or two (8-panel bay only) distribution panels per side with a “panel length” internal ground/return bar.
- Each bay can easily be configurable for top or bottom feed.
- Each bay is equipped with a monitor unit. The monitor unit provides local and remote access to data and alarms for the voltage, current, power, and energy delivered through the distribution bay. The monitor unit contains a color TFT display and keypad for local access. The monitor unit provides an Ethernet port and comes with comprehensive webpages for remote access. The monitor unit can also be accessed via SNMP (v2 and v3), TL1 (over Ethernet), or MODBUS (over Ethernet) for remote system management. The monitor unit supports software upgrade via its USB port. A machine-to-machine HTTP interface is also available. Refer to the monitor unit instructions (UM1M832DNA) for more information.

Each bay includes an SM-DUE. The SM-DUE sends information to the monitor unit and the monitor unit monitors and displays load voltage, load current, and fuse alarm / circuit breaker alarm status of each distribution panel in the bay.

The advanced distribution panels are equipped with an SM-DUH2. The SM-DUH2 sends information to the monitor unit and the monitor unit additionally displays load voltage, load current, and fuse alarm / circuit breaker alarm status of each distribution device in the advanced distribution panel.

Also provided in each bay is an IB2 (interface board) connected to the monitor unit. The IB2 board provides four (4) programmable form C- relay outputs.

- Choices of distribution panels is a panel that accepts TPS / TLS and TPL-B fuses and a panel that accepts bullet nose type circuit breakers and/or bullet nose type TPS / TLS fuseholders. The bullet nose type distribution panel is available in a standard configuration or an advanced configuration. The standard configuration allows for monitoring the panel as one unit. The advance configuration also allows for monitoring each individual distribution device on the panel.

Refer to SAG582140600 (System Application Guide) for additional information.

## 3 Installation Acceptance Checklist

Provided in this section is an Installation Acceptance Checklist. This checklist helps ensure proper installation and initial operation of the system. As the procedures presented in this document are completed, check the appropriate box on this list. If the procedure is not required to be performed for your installation site, also check the box in this list to indicate that the procedure was read. When installation is done, ensure that each block in this list has been checked. Some of these procedures may have been factory performed for you.



**NOTE!** The system is not powered up until the end of this checklist.



**NOTE!** Some of these procedures may have been performed at the factory for you.

### **Physically Installing the System**

- Bay Mounted to the Floor
- Distribution Panel Paralleling Bar(s) Installed (if required)
- Internal Ground/Return Busbar Paralleling Bar Installed (if required)
- Input Feed and Shunt Assembly Installed (if required)

### **Making Switch and Jumper Settings**

- Factory Switch Settings on IB2 Board Verified
- Factory Switch Settings on SM-DUE Board Verified
- Factory Jumper Settings on SM-DUE Board Verified
- Factory Switch Settings on SM-DUH2 Board Verified

### **Making Electrical Connections**

- Bay Frame Grounding Connection Made
- External Alarm, Reference, Monitoring, and Control Connections Made
- Return Connected to RTN A and/or RTN B.
- System Ethernet Connection Made
- Optional Transient Voltage Surge Suppressor (TVSS) Device Installed and Wired
- Load Distribution Connections Made
- DC Input Connections Made

### **Installing Circuit Breakers and Fuses**

- Circuit Breakers and Fuses Installed

### **Initially Starting, Configuring, and Checking System Operation**

- System Started, Configured, and Checked

## 4 Physically Installing the System

### 4.1 General Requirements

- This product is intended only for installation in a restricted access location on or above a non-combustible surface.
- This BDF/CBB uses natural convection. Equipment is designed for use in environmentally controlled space.
- This product is intended for installation in network telecommunication facilities (CO, vault, hut, or other environmentally controlled electronic equipment enclosure).
- This product is intended to be connected to the common bonding network in a network telecommunication facility (CO, vault, hut, or other environmentally controlled electronic equipment enclosure).
- The DC return connection to this system can remain isolated from system frame and chassis (DC-I).
- The installer should be familiar with the installation requirements and techniques to be used in securing the bay to the floor.
- Typical industry standards recommend minimum aisle space clearance of 26" for the front of the bay and 2' for the rear of the bay.
- Ventilating openings must not be blocked and temperature of air entering the bay must not exceed rated operating ambient temperature range found in SAG58214-0600.

### 4.2 Physical Security

This product is designed and intended to be deployed and operated in a physically secure and network firewall-protected location. Vertiv recommends a review of the physical security and operating environment of the unit. Since an attacker or disgruntled user can cause serious disruption, below are some recommended best practices that include, but are not limited to:

- Restrict access to areas, racks, and units with encrypted card RFID/badges, unique multi-factor passcode authentication for access, man traps, and biometric scanners for physical access to the equipment.
- Have trusted and background-checked security guards with 24x7x365 physical presence and written logs to help document and note physical access to a data center, building, rack, and so on.
- Restrict physical access to telecommunications equipment and network cabling. Physical access to the telecommunications lines and network cabling should be restricted to protect against attempts to intercept or sabotage communications. Best practices include use of metal conduits for the network cabling running between equipment cabinets.
- All USB, RJ45, and/or any other physical ports should be restricted on the units.
- Do not connect removable media (such as USB devices, SD cards, and so on) for any operation (such as firmware upgrade, configuration change, or boot application change) unless the origin of media is known and trusted. Before connecting any portable device through a USB port or SD card slot, scan the device for malware and viruses.

## 4.3 Installing the Bays

### Ventilation Requirements

Refer to the “General Requirements” on page 4.

### Placing and Securing the Bay to the Floor

Refer to the “General Requirements” on page 4.

### Procedure

1. Locate where the bay is to be placed.
2. Drill mounting holes in the floor per site requirements. Refer to Figure 4.1 and Figure 4.2 for floor mounting holes drilling dimensions.
3. Place the bay in position.
4. Secure the bay to the floor by installing mounting hardware into floor per site requirements.

Figure 4.1 List 01 and List 07 Floor Hole Drilling Pattern Dimensions

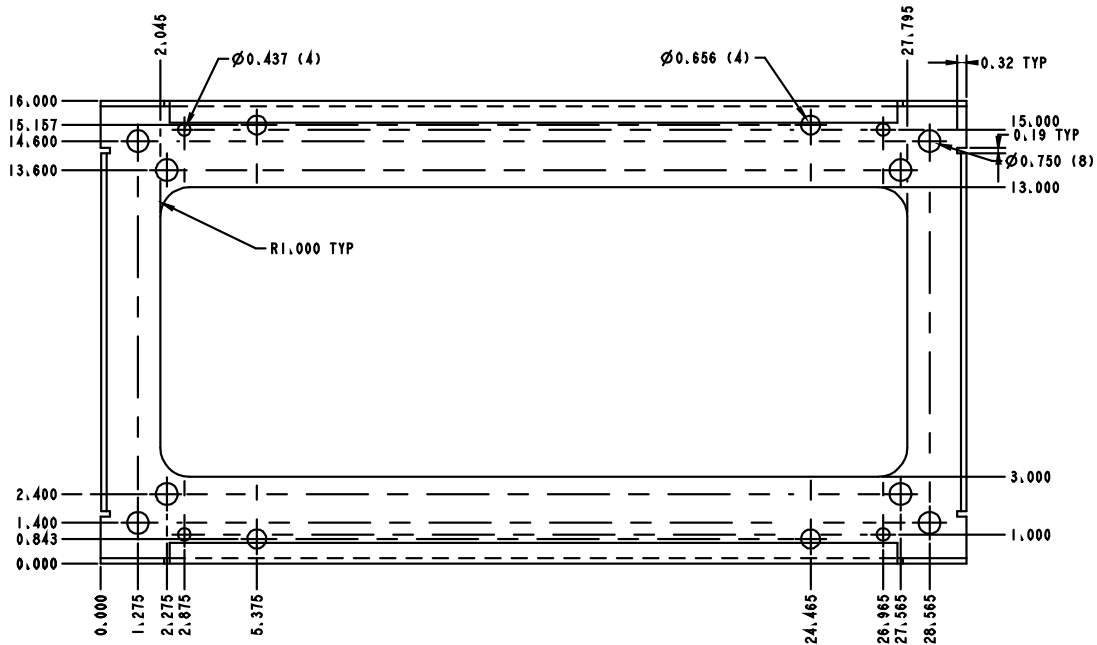
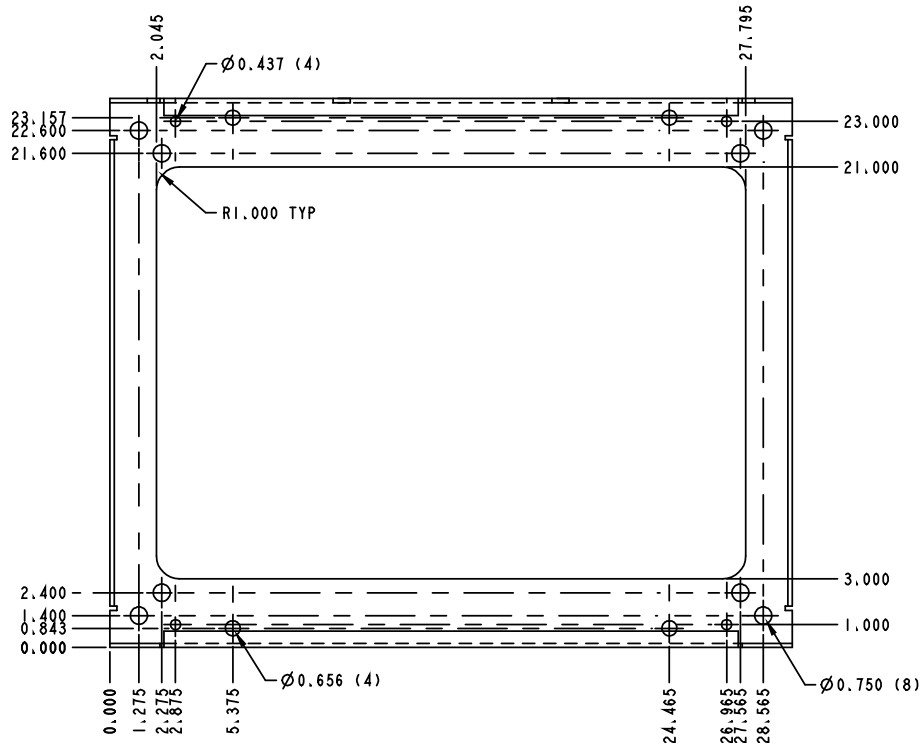

Figure 4.2 List 03 and List 09 Floor Hole Drilling Pattern Dimensions



## 4.4 Installing Distribution Panel Paralleling Bars (if furnished)

### Procedure

1. If distribution panel paralleling bars (List 30, List 31, P/N 563497) are furnished, attach the paralleling bars per Figure 4.3.

**Figure 4.3** Installing Distribution Panel Paralleling Bars (List 30, List 31, P/N 563497)

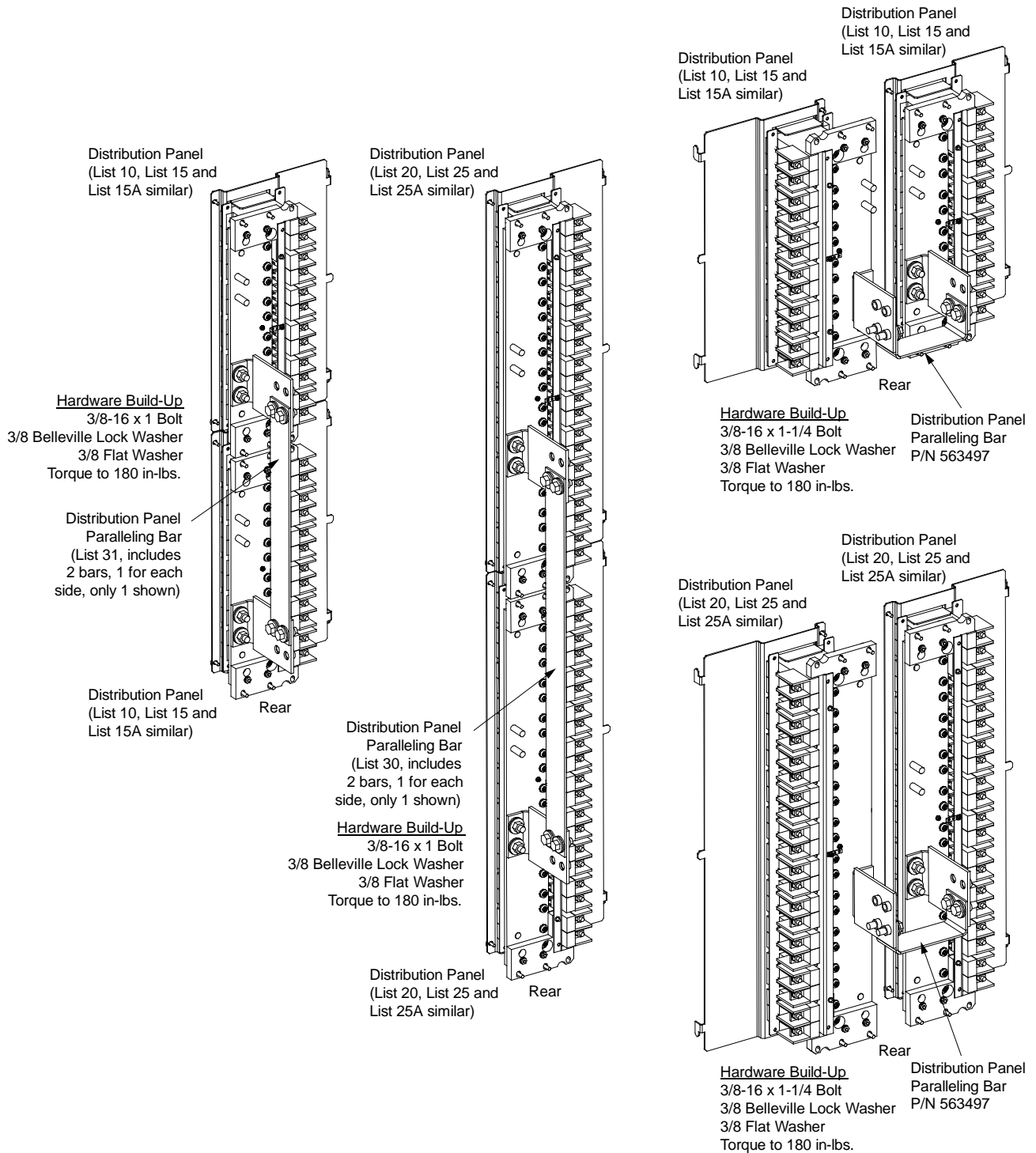

## 4.5 Installing the Internal Ground/Return Busbar Paralleling Bars List 39 (8-Panel Bay Only) (if furnished)

### Procedure

1. If internal ground/return busbars (List 17) are furnished and the paralleling bars (List 39) are furnished, attach the paralleling bars per Figure 4.4.

Figure 4.4 Installing the Internal Ground/Return Busbar Paralleling Bars (List 39) (8-Panel Bay Only)

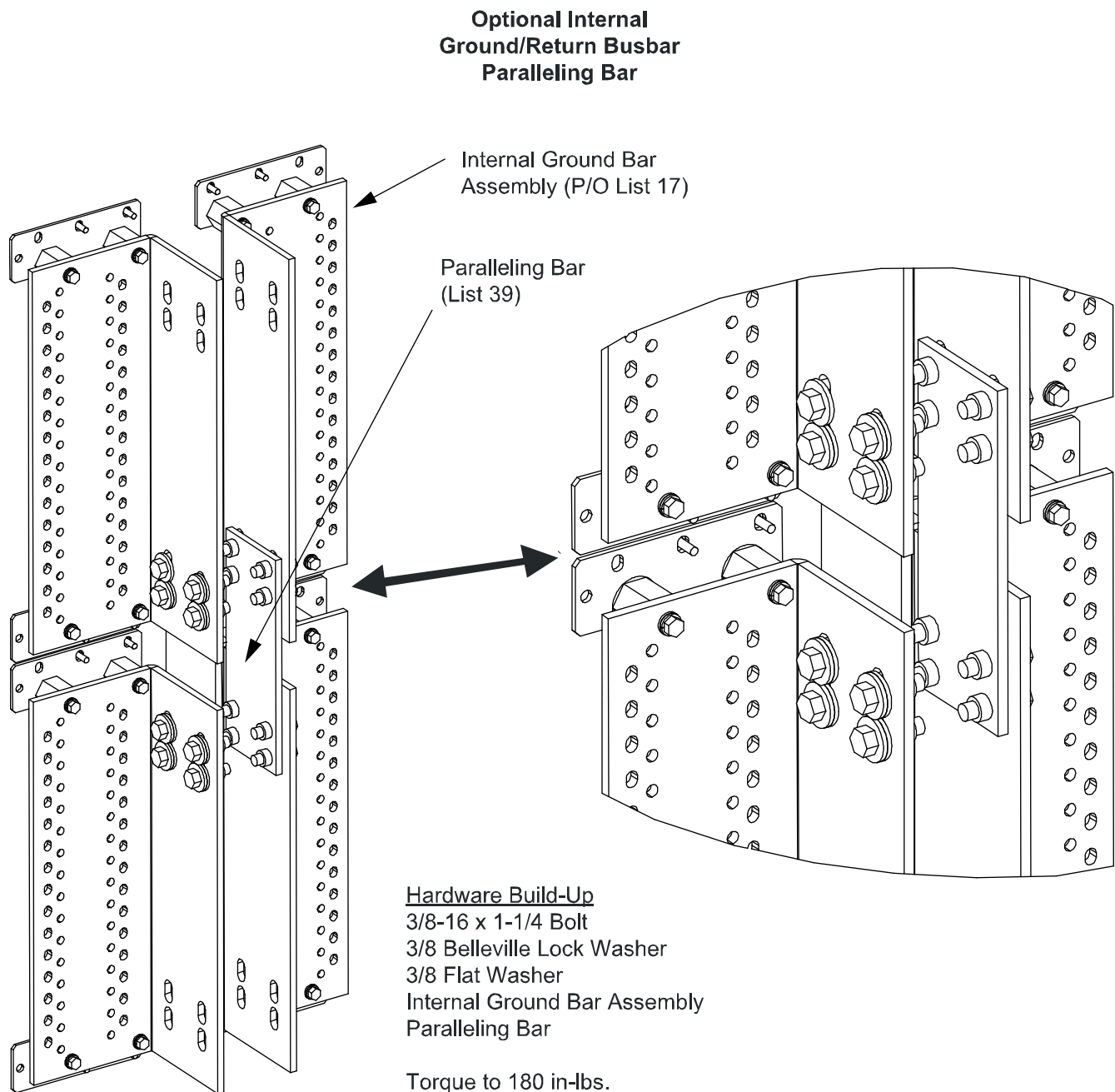

## 4.6 Field Installing Bay Input Feed and Shunt Assembly List 43

### Procedure

1. Refer to Figure 4.5.

Figure 4.5 Field Installing Bay Input Feed and Shunt Assembly (List 43) (cont'd on next page)

Location and Orientation View

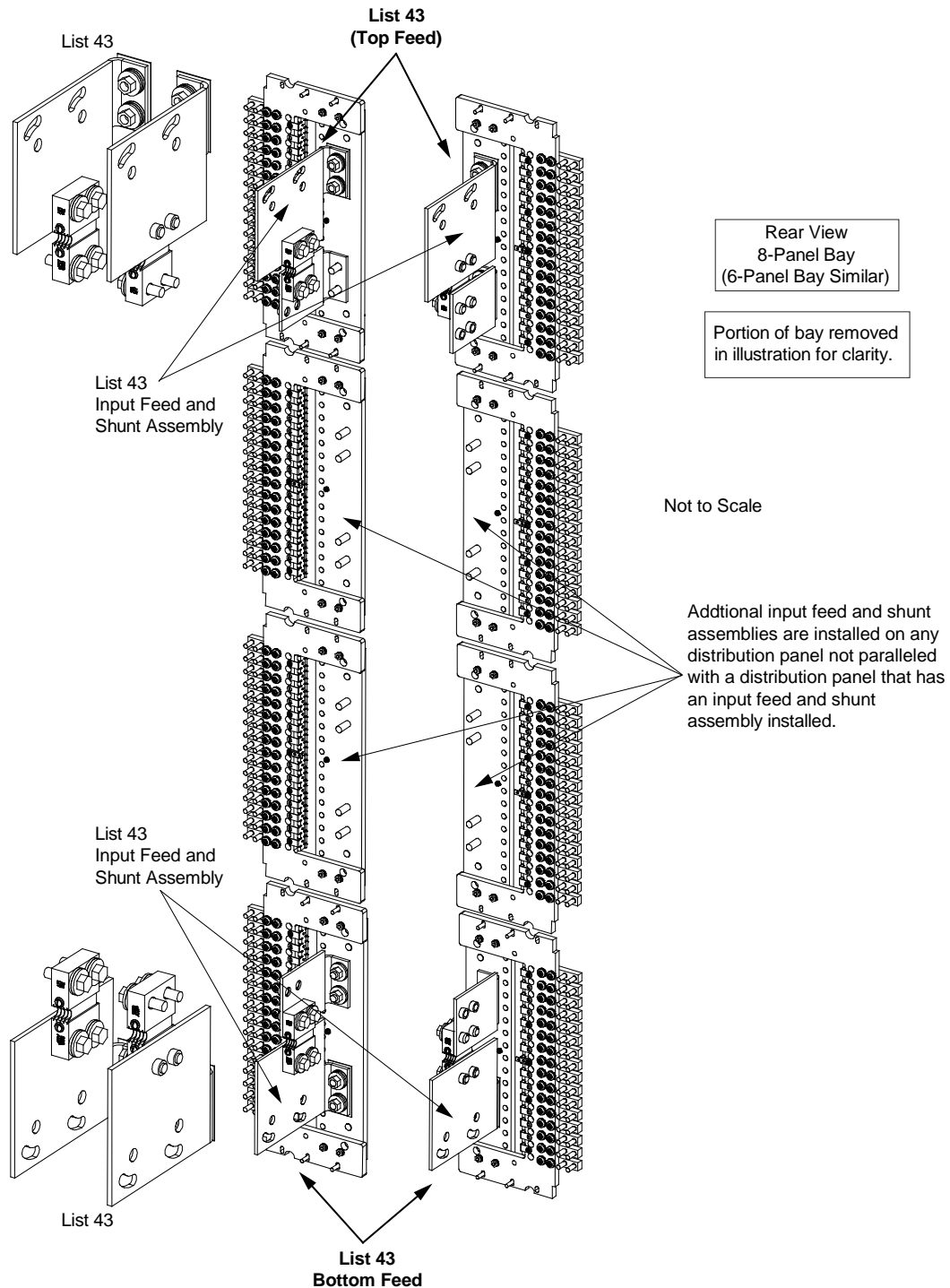
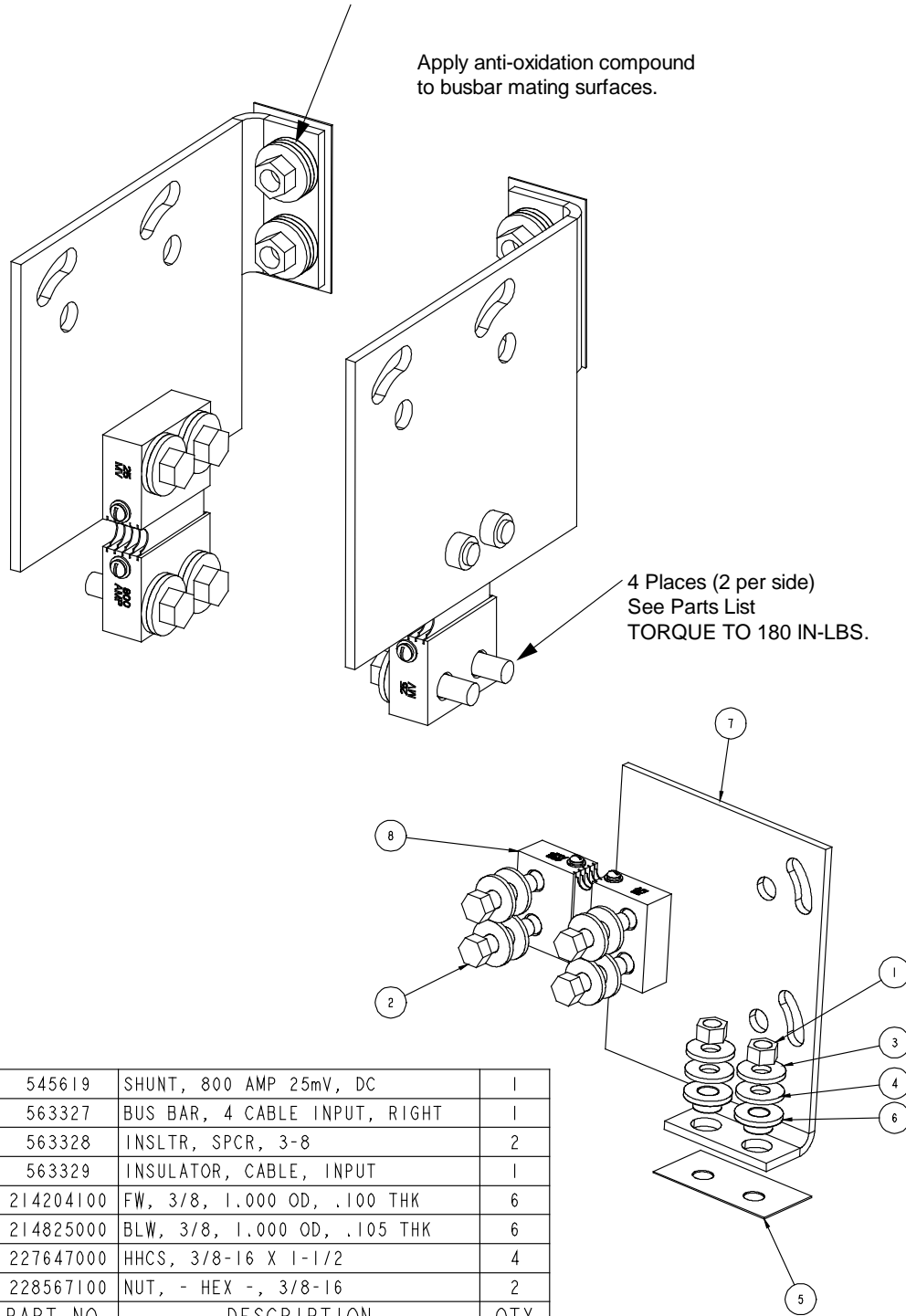

**Figure 4.5 Field Installing Bay Input Feed and Shunt Assembly (List 43) (cont'd from previous page, cont'd on next page)**

**Hardware Build-Up and Torque Values**

4 Places (2 per side)  
See Parts List  
TORQUE TO 180 IN-LBS.

Apply anti-oxidation compound to busbar mating surfaces.



8	545619	SHUNT, 800 AMP 25mV, DC	1
7	563327	BUS BAR, 4 CABLE INPUT, RIGHT	1
6	563328	INSLTR, SPCR, 3-8	2
5	563329	INSULATOR, CABLE, INPUT	1
4	214204100	FW, 3/8, 1.000 OD, .100 THK	6
3	214825000	BLW, 3/8, 1.000 OD, .105 THK	6
2	227647000	HHCS, 3/8-16 X 1-1/2	4
1	228567100	NUT, - HEX -, 3/8-16	2
INDEX	PART NO.	DESCRIPTION	QTY
PARTS/MATERIAL LIST			

Figure 4.5 Field Installing Bay Input Feed and Shunt Assembly (List 43) (cont'd from previous page, cont'd on next page)

Shunt Lead Connections  
8-Panel Bay, Top Feed

Note

All shunt leads not factory connected to shunts are factory shorted together and insulated if no panel is installed; otherwise, if a panel is installed the leads are shorted together and terminated on the bus.

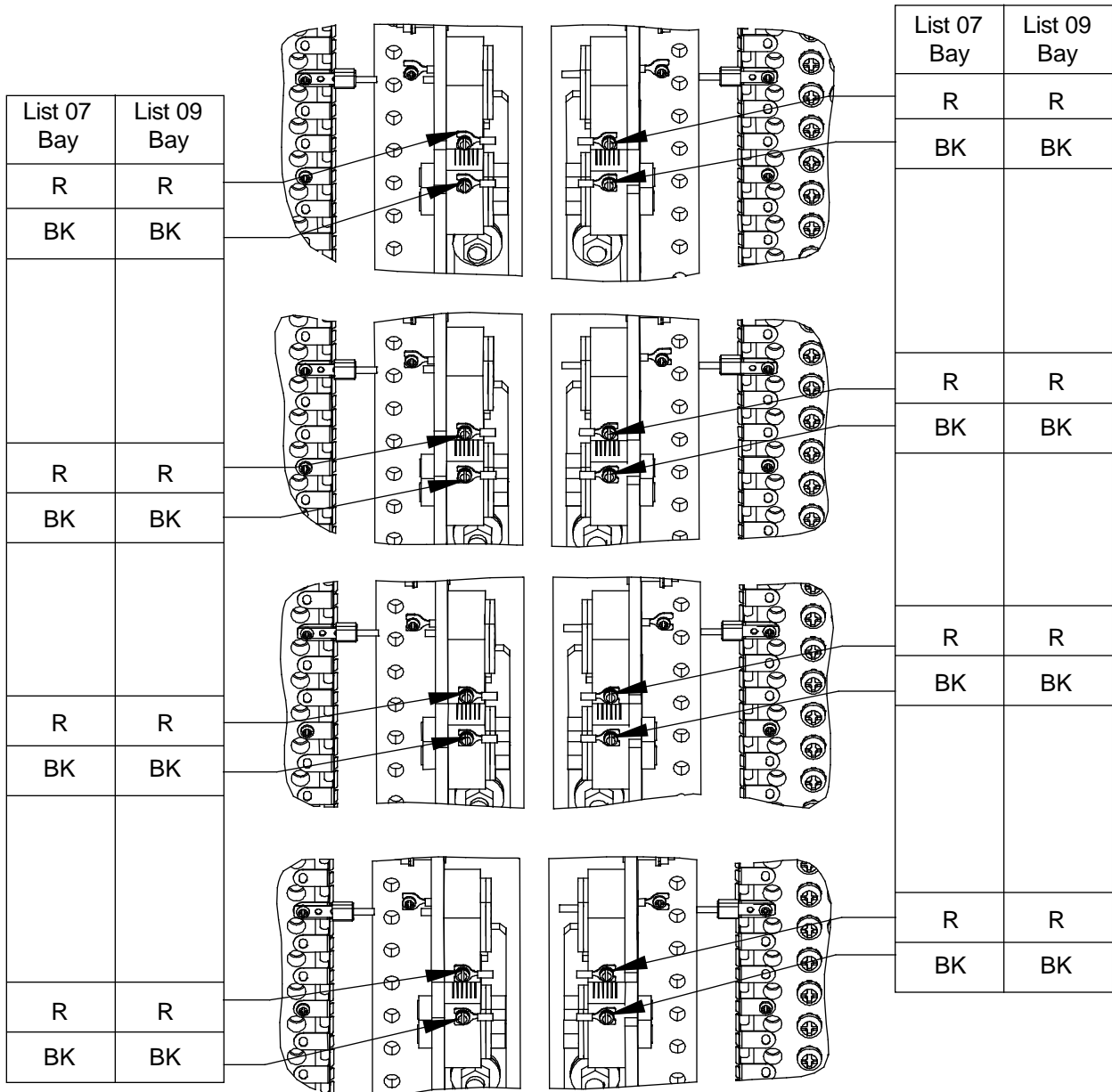

Figure 4.5 Field Installing Bay Input Feed and Shunt Assembly (List 43) (cont'd from previous page, cont'd on next page)

Shunt Lead Connections  
8-Panel Bay, Bottom Feed

**Note**

All shunt leads not factory connected to shunts are factory shorted together and insulated if no panel is installed; otherwise, if a panel is installed the leads are shorted together and terminated on the bus.

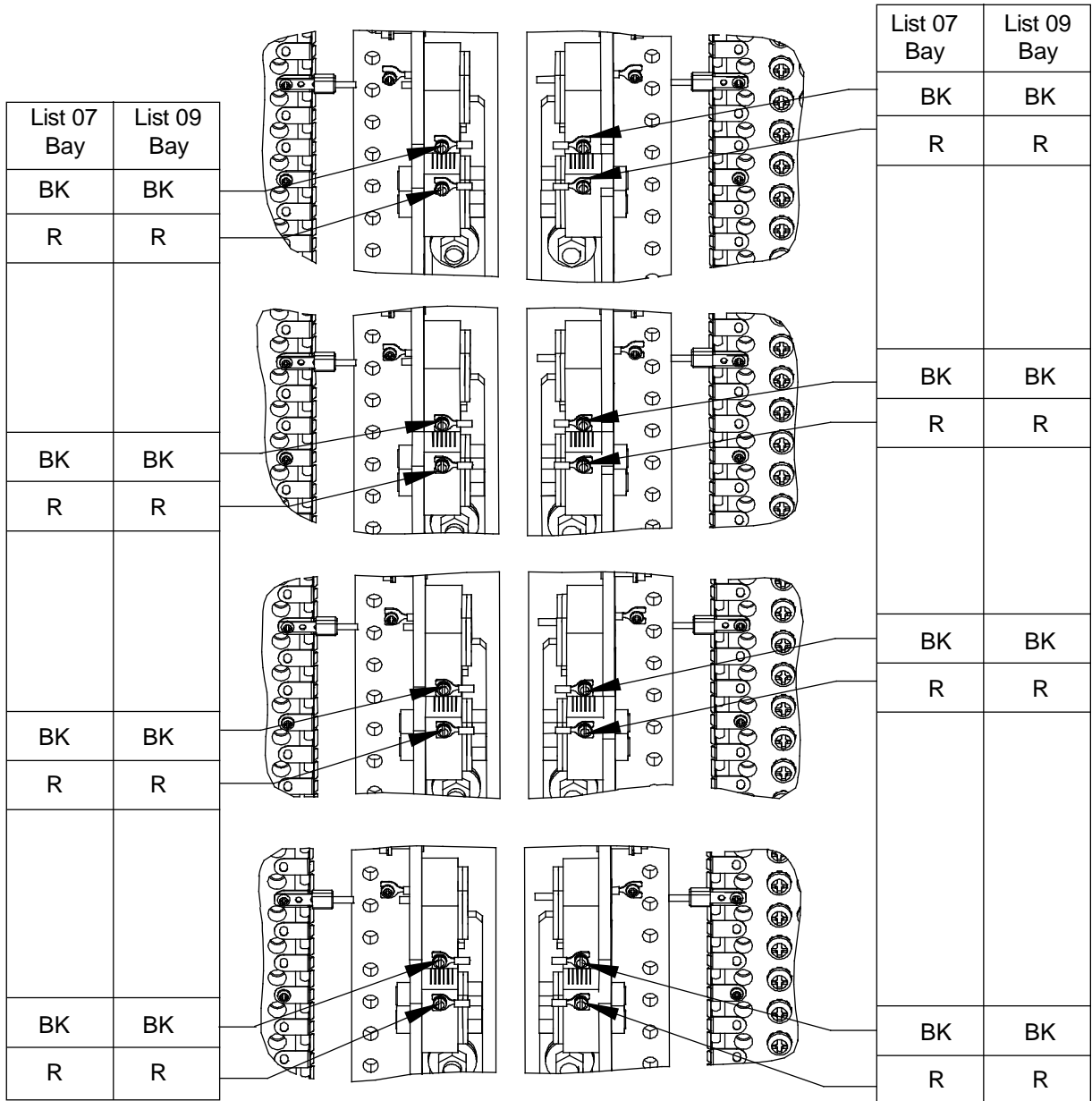

Figure 4.5 Field Installing Bay Input Feed and Shunt Assembly (List 43) (cont'd from previous page, cont'd on next page)

Shunt Lead Connections  
6-Panel Bay, Top Feed

Note

All shunt leads not factory connected to shunts are factory shorted together and insulated if no panel is installed; otherwise, if a panel is installed the leads are shorted together and terminated on the bus.

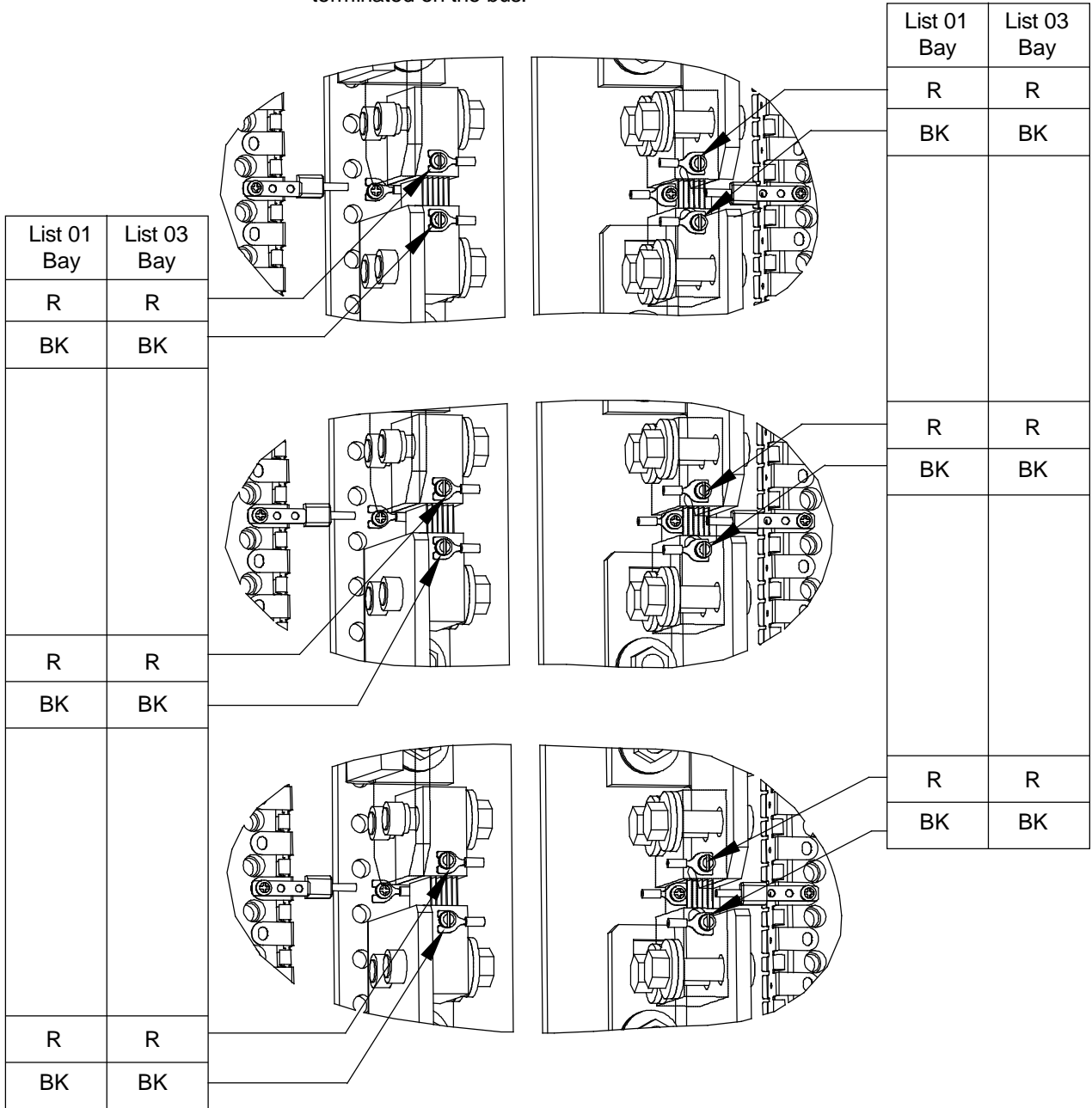
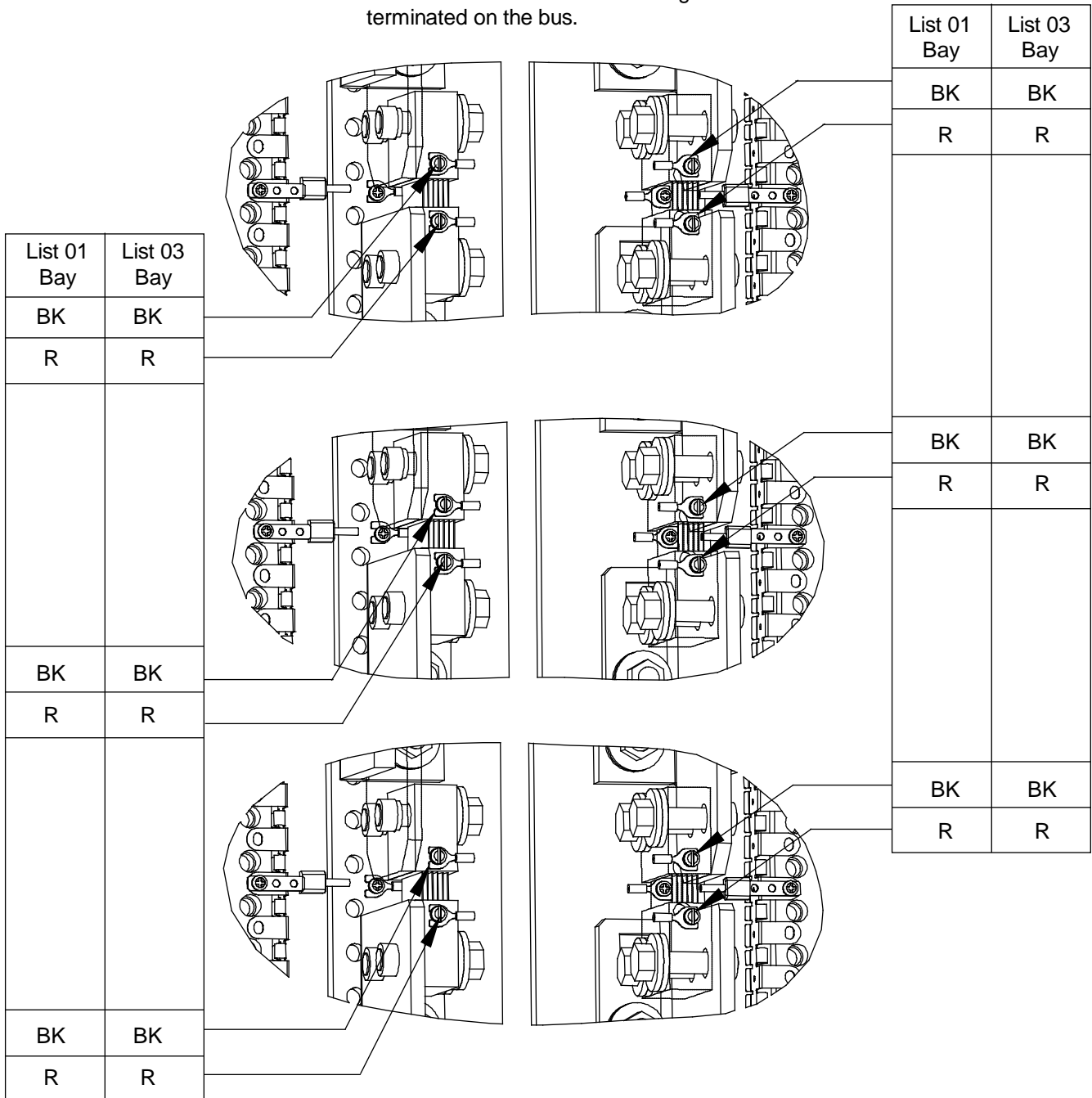

Figure 4.5 Field Installing Bay Input Feed and Shunt Assembly (List 43) (cont'd from previous page)

Shunt Lead Connections  
6-Panel Bay, Bottom Feed

**Note**

All shunt leads not factory connected to shunts are factory shorted together and insulated if no panel is installed; otherwise, if a panel is installed the leads are shorted together and terminated on the bus.



## 5 Making Switch and Jumper Settings

### 5.1 Circuit Cards with Jumpers and/or Switches Locations

Refer to Figure 5.1.

Figure 5.1 Circuit Cards with Jumpers and/or Switches Locations

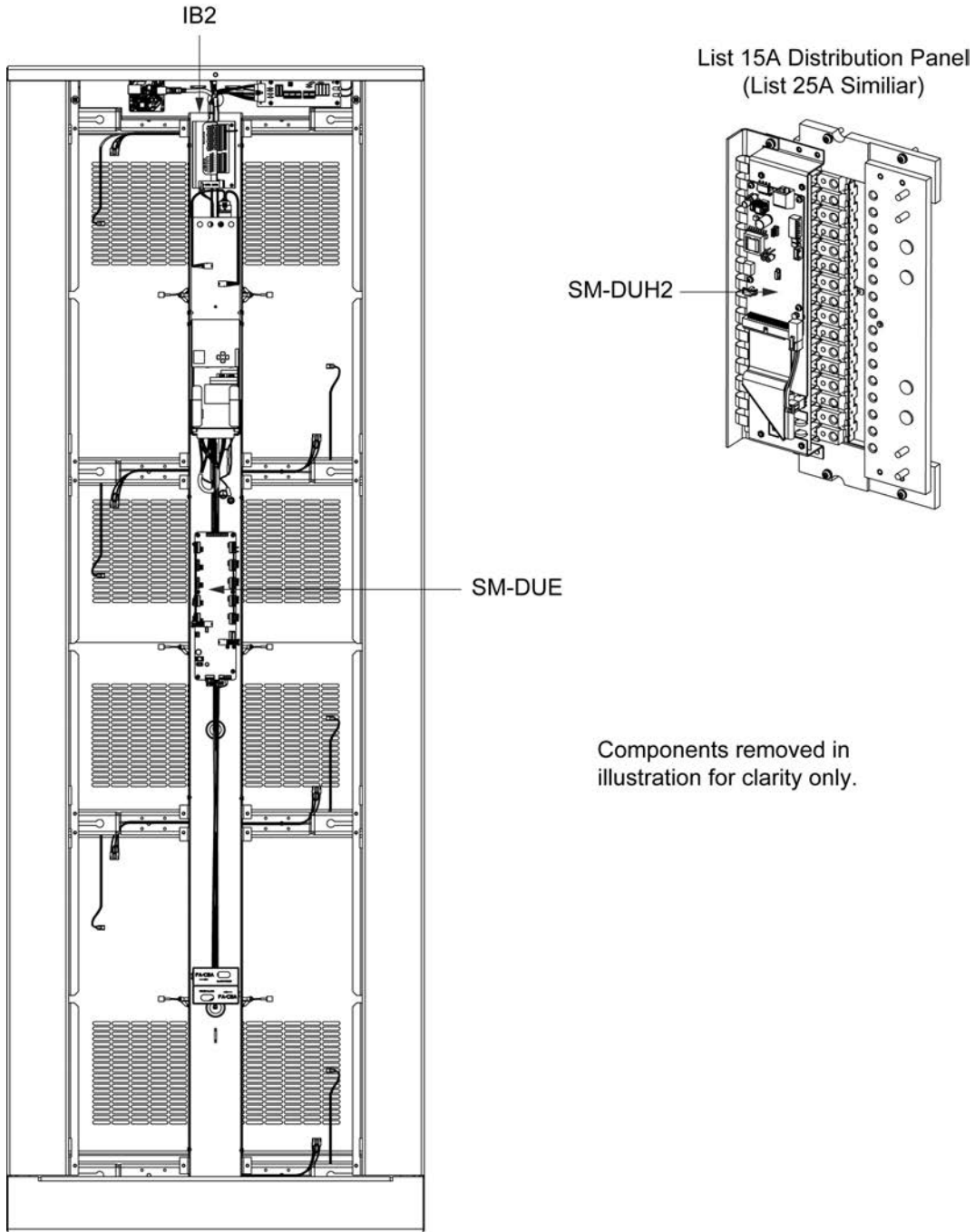

Front  
(panels removed for clarity only)

## 5.2 Switch Settings on IB2 Interface Board

Dip switch SW1 on the IB2 board is used to set the communications address for this board. Refer to Table 5.1 for SW1 settings. Refer to Figure 5.1 for circuit card location. Refer to Figure 5.2 for SW1 location.

Perform the following procedure to verify the factory settings. This procedure can also be used to make adjustments on a replacement circuit card.

### Procedure

1. Ensure SW1 is set per Table 5.1. Refer to Figure 5.2 for location.

Table 5.1 IB2 Interface Board Switch Settings

Setting	DIP Switch SW1	
	1	2
IB2	OFF	OFF

Figure 5.2 IB2 Interface Board Switch Location and Settings

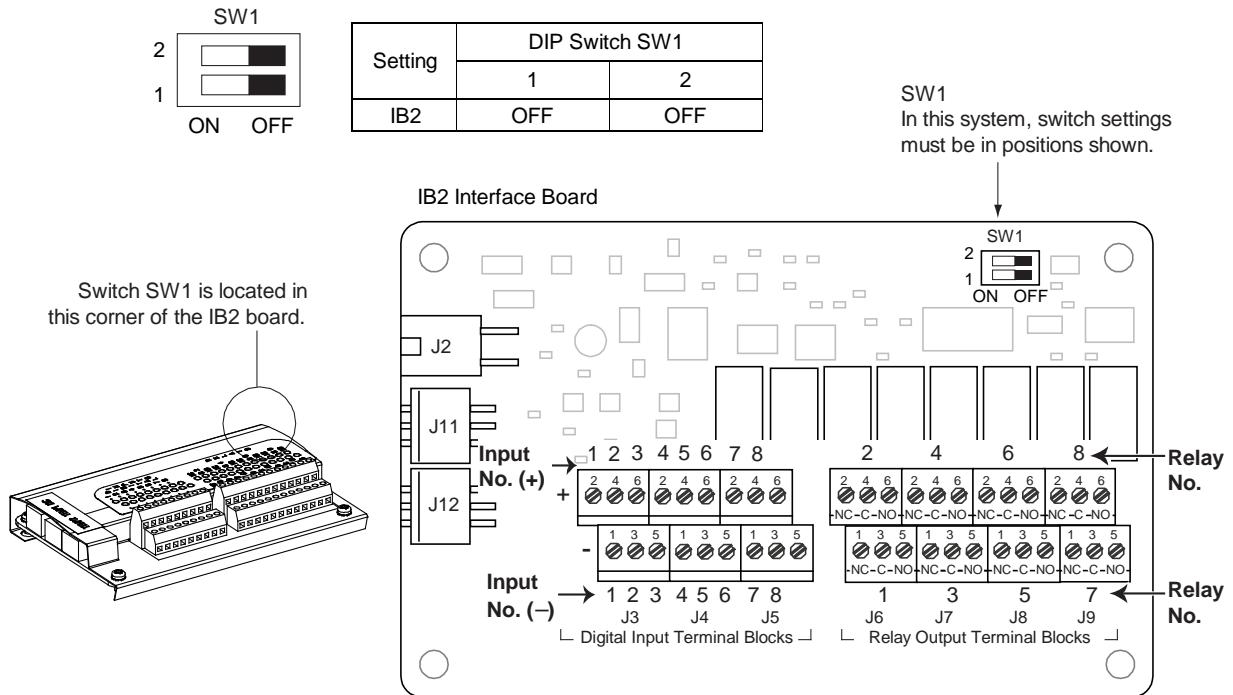

## 5.3 Switch Settings on SM-DUE

An SM-DUE is located in each bay. The SM-DUE is used to monitor individual distribution panels in the bay.

Dip switch SW1 on the SM-DUE board is used for parameter settings. Refer to Table 5.2 for SW1 settings. Refer to Figure 5.1 for circuit card location. Refer to Figure 5.3 for SW1 location.

Perform the following procedure to verify the factory settings. This procedure can also be used to make adjustments on a replacement circuit card.

### Procedure

1. Ensure SW1 is set per Table 5.2. Refer to Figure 5.3 for location.



**NOTE!** The permissible address range is 219 to 226. The default address of the board is 219.

**Table 5.2 SM-DUE Switch Settings (cont'd on next page)**

Communication Address (Use Switch 1, 2, and 3 of SW1)			Function Descriptions
1	2	3	
Off	Off	Off	Base Default
Off	Off	On	Base +1
Off	On	Off	Base +2
Off	On	On	Base +3
On	Off	Off	Base +4
On	Off	On	Base +5
On	On	Off	Base +6
On	On	On	Base +7
Baud Rate for Serial Port Communication (Use Switch 4 of SW1)			Function Descriptions
4			
Off			19200 (Note 1)
On			9600
Parameter of Shunt Setting Configured by Hardware or Software (Use Switch 5 of SW1)			Function Descriptions
5			
Off			Shunt parameter is set through software (Note 1).
On			Shunt parameter is set through DIP switch.

**Table 5.2 SM-DUE Switch Settings (cont'd from previous page)**

Shunt Voltage (Use Switch 6 of SW1)		Function Descriptions
6		
Off		25 mV (Note 1)
On		50 mV
Shunt Current (Use Switch 7 and 8 of SW1)		Function Descriptions
7	8	
Off	Off	500 A (Note 1)
Off	On	1000 A
On	Off	1500 A
On	On	2000 A

Note 1: Setting for this system.

**Figure 5.3 SM-DUE Switch Location**

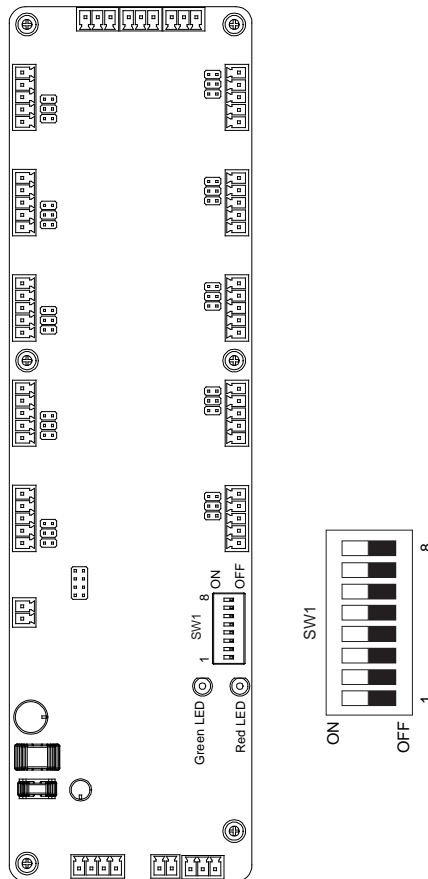

## 5.4 Jumper Settings on SM-DUE

An SM-DUE is located in each bay. The SM-DUE is used to monitor individual distribution panels in the bay.

There are thirty (30) 2-pin jumpers on the SM-DUE. Three (3) for each of the ten (10) SM-DUE's analog inputs. These jumpers must be set according to the type of analog signal that will be measured. Refer to Table 5.3 for jumper settings. Refer to Figure 5.1 for circuit card location. Refer to Figure 5.4 for jumper locations.

Perform the following procedure to make the required setting per your site requirements.

This procedure can also be used to make adjustment on a replacement circuit card.

### 5.4.1 Analog Inputs AI1 to AI10

#### **Procedure**

1. Ensure the jumpers for each analog input are set per Table 5.3. Refer to Figure 5.4 for location.

**Table 5.3 SM-DUE Jumper Settings**

Type of input Signal	Range	Jumper Position		
		1-2	3-4	5-6
Measure General -Purpose Transducer	0 VDC to 10 VDC	OFF	OFF	OFF
Measure Shunt Current	0 mV DC to 50 mV DC (Note 1)	ON	OFF	ON
Measure General-Purpose Transducer	0 mA to 20 mA	ON	ON	OFF
Measure Temperature Sensor	1 uA/K	ON	OFF	OFF

Note 1: Setting for this system.

Figure 5.4 SM-DUE Jumper Location

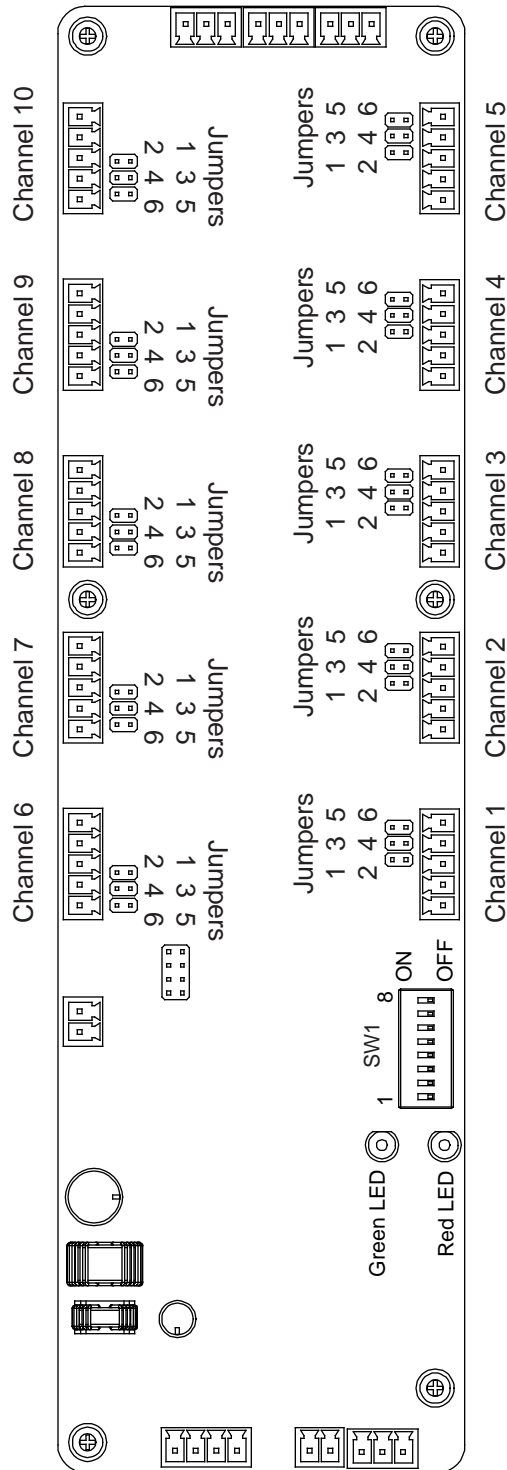

## 5.5 Switch Settings on SM-DUH2

The SM-DUH2 is used in a List 15A and List 25A distribution panel to monitor individual distribution devices in the distribution panel.

Dip switch SW1 on the SM-DUH2 board is used to set the communications address for this board and the communications baud rate. Refer to Table 5.4 for SW1 settings. Refer to Figure 5.1 for circuit card location. Refer to Figure 5.5 for SW1 location.

Perform the following procedure to verify the factory settings. This procedure can also be used to make adjustments on a replacement circuit card.

### Procedure

1. Ensure SW1 is set per Table 5.4. Refer to Figure 5.5 for location.

**Table 5.4 SM-DUH2 Switch Settings**

SW1								Offset Address	Actual Address
1	2	3	4	5	6	7	8		
Off	Off	Off	Off	Off	Off	NA		0	211
On	Off	Off	Off	Off	Off			1	212
Off	On	Off	Off	Off	Off			2	213
On	On	Off	Off	Off	Off			3	214
Off	Off	On	Off	Off	Off			4	215
On	Off	On	Off	Off	Off			5	216
Off	On	On	Off	Off	Off			6	217
On	On	On	Off	Off	Off			7	218
NA						OFF	N/A	Communication Baud Rate: 19200 (Note 1)	
NA						ON	N/A	Communication Baud Rate: 9600	

Note 1: Setting for this system.

Figure 5.5 SM-DUH2 Switch Location

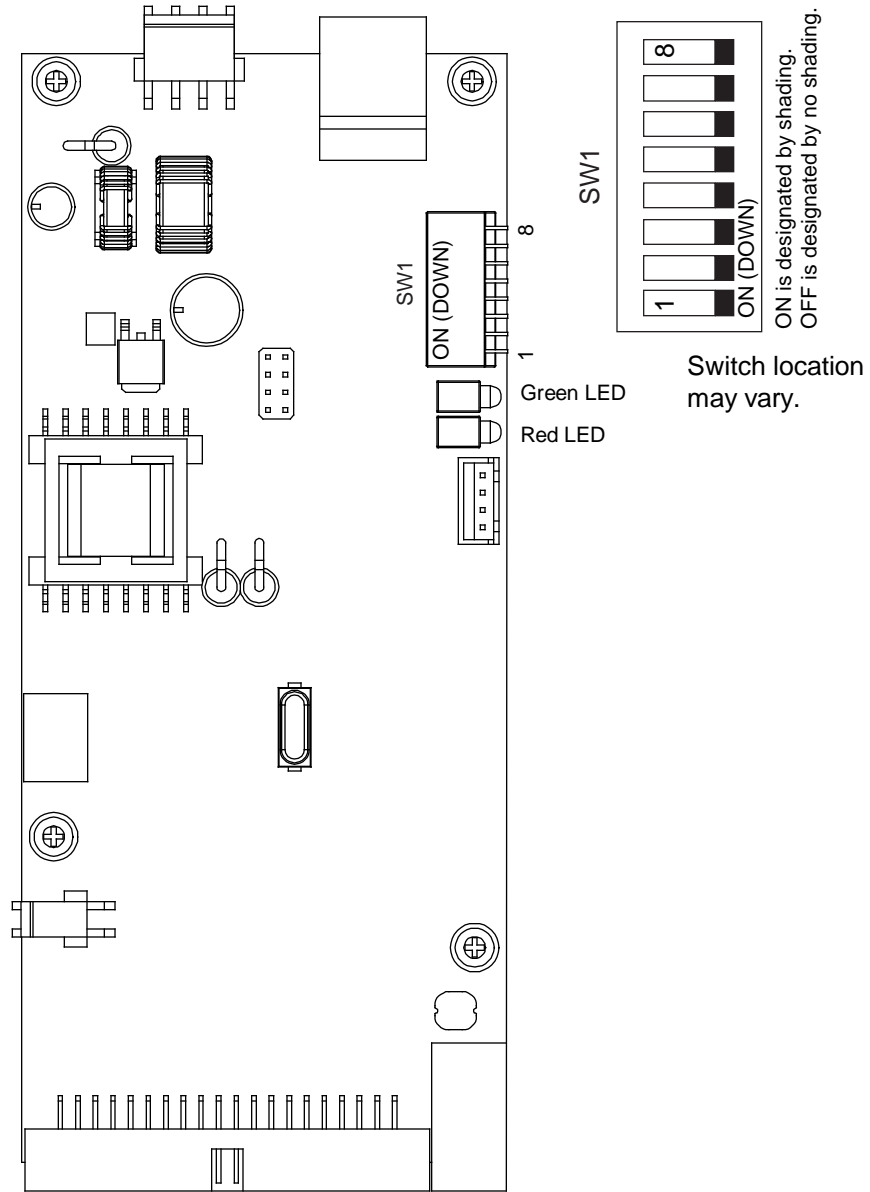

## 6 Making Electrical Connections

### 6.1 Important Safety Instructions



**DANGER!** Adhere to the “Important Safety Instructions” presented at the front of this document.

### 6.2 Wiring Considerations

All wiring and branch circuit protection should follow the current edition of the American National Standards Institute (ANSI) approved National Fire Protection Association's (NFPA) National Electrical Code (NEC), and applicable local codes. For operation in countries where the NEC is not recognized, follow applicable codes.

For wire size, branch circuit protection, crimp lug, and general wiring recommendations; refer to System Application Guide SAG58214.0600.

Lugs should be crimped per lug manufacturer's specifications.

Refer to Table 6.1 for supplemental lug crimping information when using the special application crimp lug / strap combination.

**Table 6.1 Supplemental Lug Crimping Information when Using the Special Application Crimp Lug / Strap Combination**

Crimp Lug Part No.		Crimp Tool Required <sup>1</sup> , T&B Model TBM12 or TBM15 Hydraulic Heads		
		Color Key	Die Index/ Code No.	Die Cat. Number
245393500	Burndy: YA25L-4TCG1	Pink	42H	15508
245393600	Burndy: YA26L-4TCG1	Black	45	15526
245393700	Burndy: YA27L-4TCG1	Orange	50	15530
245393800	Burndy: YA28L-4TCG1	Purple	54H	15511
514872	T & B: 256-30695-1879	Yellow	62	15510
	Burndy: YA29L-4TCG1			
514873	T & B: 256-30695-1880	Red	71	15514
	Burndy: YA31L-4TCG1			

<sup>1</sup> The lugs should be crimped to the specifications given in the manufacturer's instructions furnished with the crimp tool or lug.

### 6.3 Bay Overall Connections Diagram

Figure 6.1 Bay Overall Connections Diagram

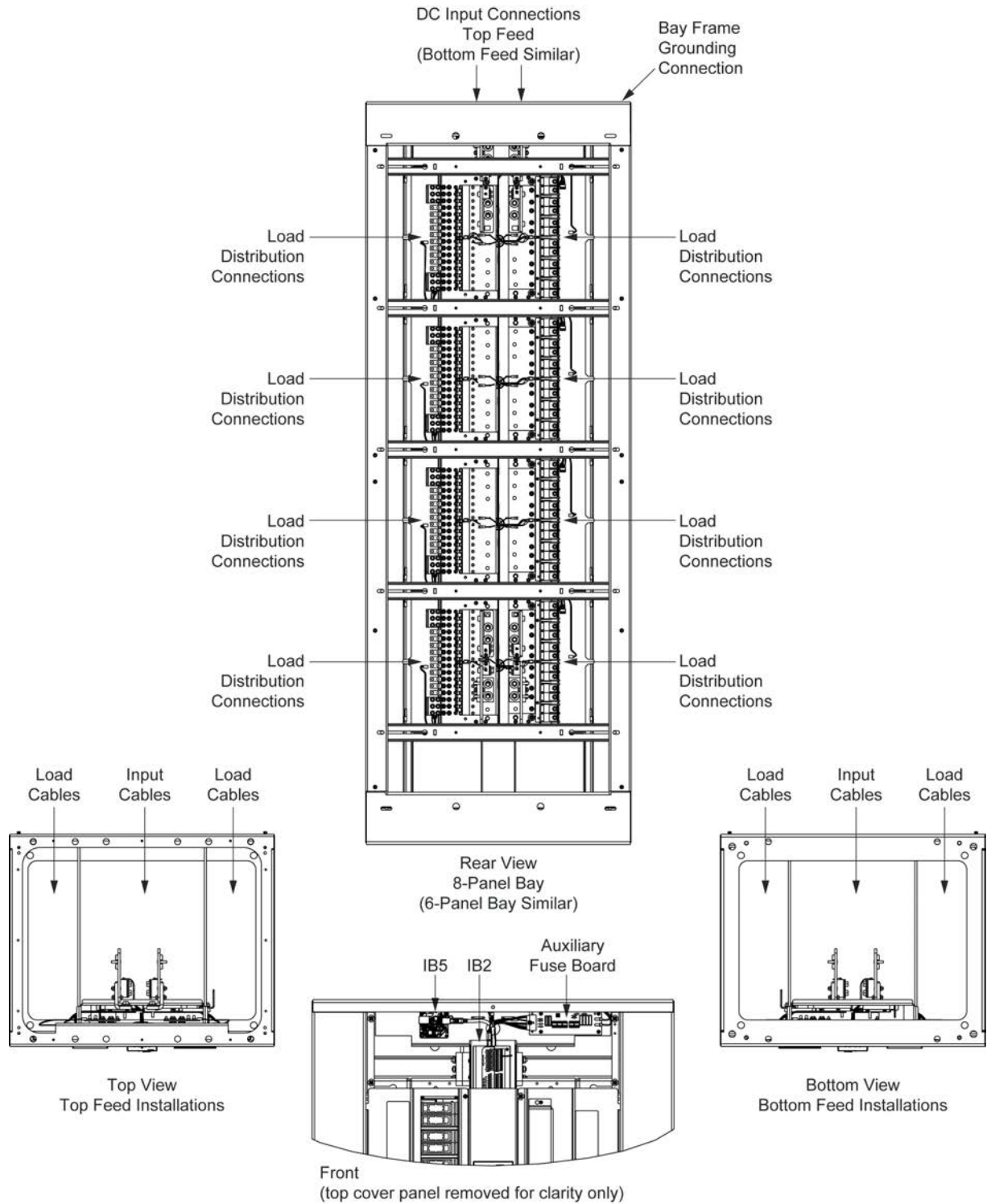

## 6.4 Bay Frame Grounding Connection

For bay grounding requirements, refer to the current edition of the American National Standards Institute (ANSI) approved National Fire Protection Association's (NFPA) National Electrical Code (NEC), applicable local codes, and your specific site requirements. For operation in countries where the NEC is not recognized, follow applicable codes.

A customer's grounding network lead can be attached to the top of each bay. Provision is made for installing a lead with a two-hole lug that has 1/4" bolt clearance holes on 5/8" centers. When using 1/4-inch hardware, recommended torque is 84 in-lbs when a standard flat washer and lock washer are used. Refer to Figure 6.2 for locations.



**NOTE!** REMOVE TAPE (IF PRESENT) FROM HOLE LOCATIONS BEFORE INSTALLING LUG.



**NOTE!** The DC return connection to this system can remain isolated from system frame and chassis (DC-I).

**Figure 6.2** Bay Frame Grounding Connection Points

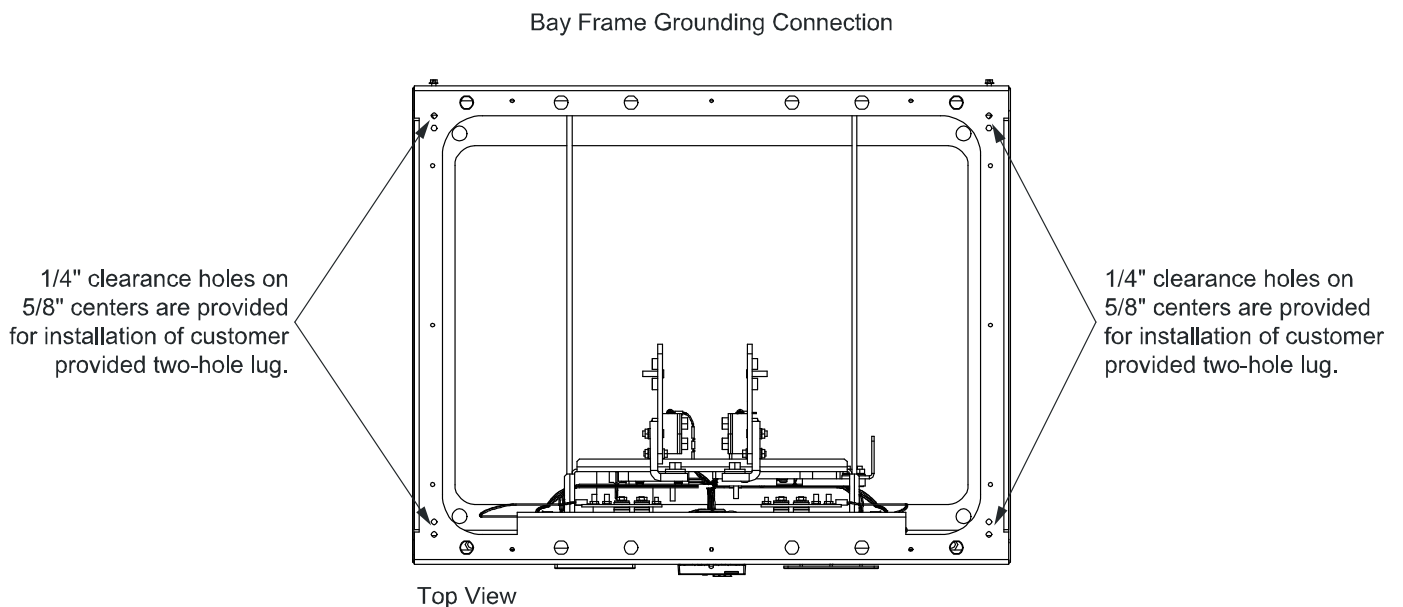

## 6.5 External Alarm, Reference, Monitoring, and Control Connections

### 6.5.1 Circuit Card locations

Refer to Figure 6.1.

### 6.5.2 IB2 (Interface Board) Connections

The IB2 (Interface Board) provides connection points for programmable relay outputs. The IB2 interface board is mounted inside the bay. Refer to Figure 6.1 for location.

#### **Programmable Relay Outputs - IB2**

Relay output leads are connected to screw-type terminal blocks located on the IB2. Recommended torque for these connections is 2.2 in-lbs. Refer to Figure 6.3 for terminal locations. Refer to Table 6.2 for pin-out information.

The IB2 provides four (4) programmable alarm relays with dry Form-C contacts. Connect up to four (4) relay outputs to relay 1 through 4 on the IB2. Refer to Figure 6.3 for terminal locations and Table 6.2 for pin-out information.

Refer to the Monitor Unit Instructions (UM1M832DNA) for programming information.

Relay Ratings: Refer to the following.

- a) 1 A Steady State @ 30 VDC.
- b) 3 A Peak @ 30 VDC.

The relays may be preprogrammed for specific functions. Refer to the configuration drawing (C-drawing) supplied with your system for your system's specific configuration.

Figure 6.3 IB2 (Interface Board) Connections

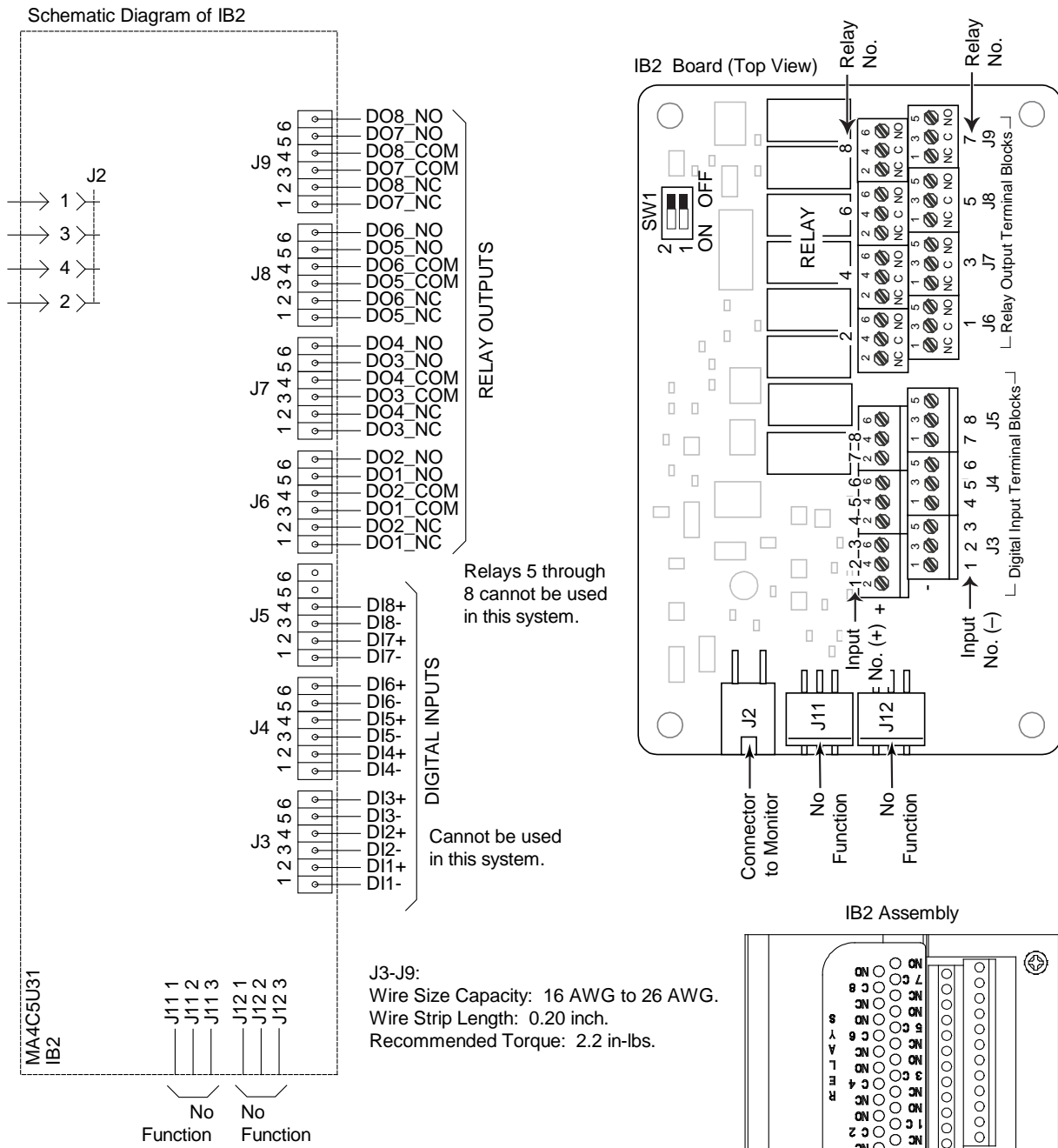

IB2 Assembly

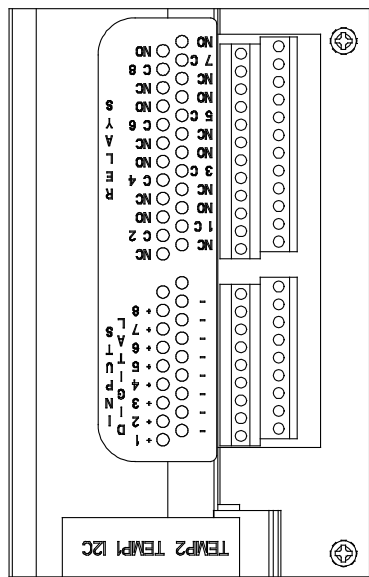

\* The relay assigned to “Critical Summary” alarm (relay 1 by default) will operate in the “Fail Safe Mode”. “Fail Safe Mode” means Relay 1 is de-energized during an alarm condition, opening the contacts between the C and NO terminals, and closing the contacts between the C and NC terminals.

The remaining seven (7) relays energize during an alarm condition, closing the contacts between the C and NO terminals, and opening the contacts between the C and NC terminals.

Not all I/O points are available for customer connection (some are used for factory system connections).

**Table 6.2 Programmable Relay Outputs – IB2**

 **NOTE!** The output relay configuration may not be set according to the factory default setting. Refer to the configuration drawing (C-drawing) supplied with your system for your system’s specific configuration.

Programmable Relay Output		IB2 Pin No.	Alarms Assigned to this Relay (Default)	Alarms Assigned to this Relay (Custom)
1	NO	J6-5		
	COM	J6-3		
	NC	J6-1		
2	NO	J6-6		
	COM	J6-4		
	NC	J6-2		
3	NO	J7-5		
	COM	J7-3		
	NC	J7-1		
4	NO	J7-6		
	COM	J7-4		
	NC	J7-2		
5	NO	J8-5	Cannot be used in this system.	
	COM	J8-3		
	NC	J8-1		
6	NO	J8-6		
	COM	J8-4		
	NC	J8-2		
7	NO	J9-5		
	COM	J9-3		
	NC	J9-1		
8	NO	J9-6		
	COM	J9-4		
	NC	J9-2		

 **NOTE!** The relay assigned to “Critical Summary” alarm (relay 1 by default) will operate in the “Fail Safe Mode”. “Fail Safe Mode” means Relay 1 is de-energized during an alarm condition, opening the contacts between the C and NO terminals, and closing the contacts between the C and NC terminals.

The remaining seven (7) relays energize during an alarm condition, closing the contacts between the C and NO terminals, and opening the contacts between the C and NC terminals.

### 6.5.3 Auxiliary Fuse Board Connections

An auxiliary fuse circuit card is located behind the top right panel in each bay. This circuit card provides four fuses for auxiliary equipment loads and two fuses for optional external (ABS) power to the system's electronics. All fuses are rated at 1-1/3A. Terminal blocks are provided on the circuit card for auxiliary load connections and external (ABS) system electronics input power connections.

Refer to Figure 6.4 for connection details. Recommended torque for terminal block connections is shown in Figure 6.4.

#### **System's Electronics External Input Connections**

Refer to the following procedure and Figure 6.4.

1. Connect terminals 1 of TB1 and TB2 to an external "Ground/Return" point.
2. Connect an external "-48V Source" to terminal 2 of TB1. For an A and B input configuration, connect a second "-48V Source" to terminal 2 of TB2.

#### **Auxiliary Load Connections**

Four circuits, each fused at 1-1/3A, are provided for connection of auxiliary loads. Refer to SAG582140600 for recommended wire size. Refer to the following procedure and Figure 6.4.



**WARNING!** Load should not exceed 80% of device rating.

1. Connect load -48V leads as shown in Table 6.3.
2. Connect load Return leads to a system ground/return bar.

**Table 6.3 Auxiliary Load Connections**

Fuse	Circuit Name	Terminal
F1	Aux Load 1A (-48V)	TB3-2
F2	Aux Load 2A (-48V)	TB3-1
F3	Aux Load 3B (-48V)	TB4-2
F4	Aux Load 4B (-48V)	TB4-1

**Figure 6.4 Auxiliary Fuse Card Connections**

**ABS and Aux. Supply Connections**

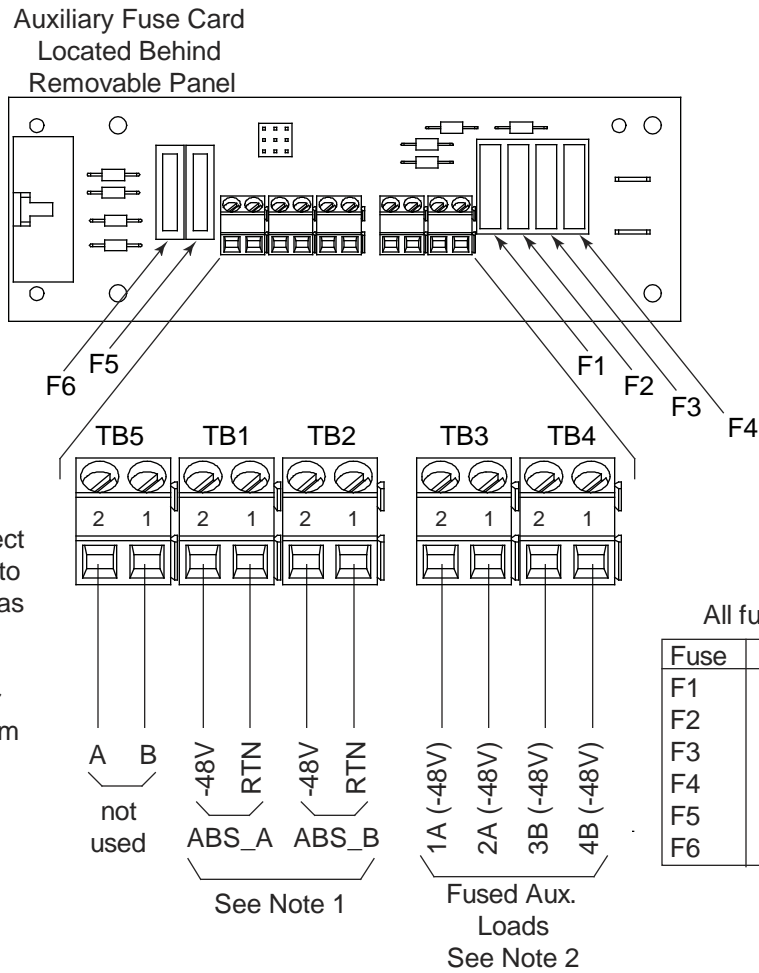

## 6.5.4 Ground/Return Input Connections for Auxiliary Fuse Card

System Ground/Return must be supplied to the auxiliary fuse card by the installer. Busbars located behind the card and accessible through the back of the bay provide connection points for A side and B side connections. Terminate each wire with a one-hole lug having a clearance hole for a 10-32 stud. Refer to Figure 6.5 for connection location. Recommended torque for terminal block connections is shown in Figure 6.5.

1. Connect the lug-terminated end of a lead to the +RTN A busbar. Connect the remaining end of the lead to the system Ground/Return busbar. If the bay is configured for A/B operation, connect lead to the A side system Ground/Return busbar.
2. If the bay is configured for A/B operation, connect the lug-terminated end of a lead to the +RTN B busbar. Connect the remaining end of the lead to the B side system Ground/Return busbar.

**Figure 6.5 Auxiliary Fuse Card Ground/Return Input Connections**

### Ground/Return Input Connections for Auxiliary Fuse Card

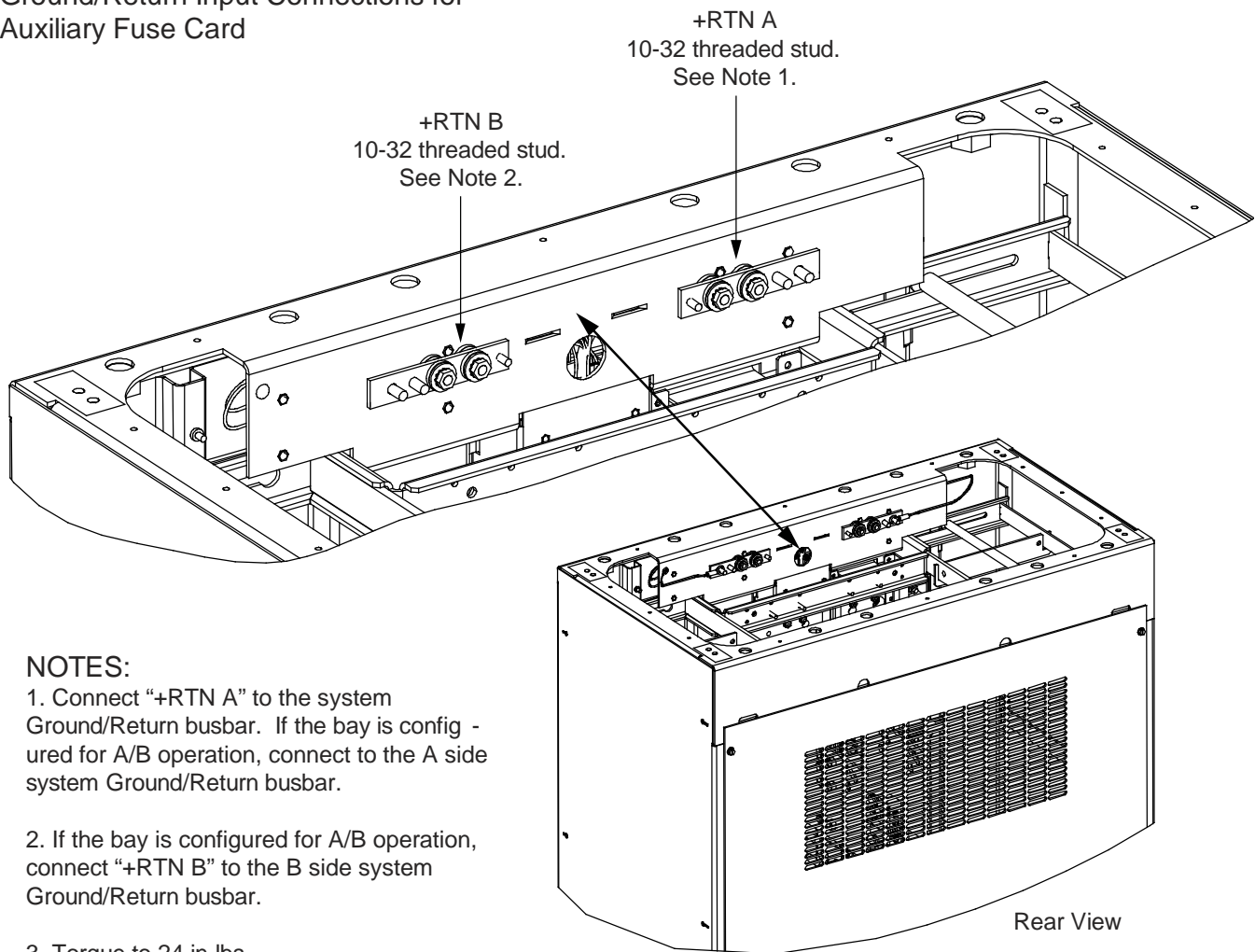

#### NOTES:

1. Connect "+RTN A" to the system Ground/Return busbar. If the bay is configured for A/B operation, connect to the A side system Ground/Return busbar.
2. If the bay is configured for A/B operation, connect "+RTN B" to the B side system Ground/Return busbar.
3. Torque to 24 in-lbs.

## 6.6 System Ethernet Port Connections

The monitor unit provides a Web Interface via an Ethernet connection to a TCP/IP network. This interface can be accessed locally on a computer and/or remotely through a network. The system has two Ethernet ports. One located on the monitor unit top panel and the other located on the IB5 board. The functions of these Ethernet ports are as follows.

### 6.6.1 Monitor Unit Top Panel Ethernet Port

An RJ-45 10BaseT jack is provided on the top panel of the monitor unit for connecting a computer directly to the monitor unit. This jack has a standard Ethernet pin configuration scheme, twisted pair. Refer to Figure 6.6 for location. Refer to the Monitor Unit Instructions (UM1M832DNA) for operational details.



**NOTE!** Your system has an IB5 board. DO NOT connect your Local Area Network (LAN) to the monitor unit's top panel Ethernet port.

#### Default Monitor Unit Ethernet Port Parameters

Default IP address is 192.168.100.100.

### 6.6.2 IB5 Board Ethernet Port

An RJ-45 10BaseT jack is provided on the IB5 board for connection into a customer's network. Use this Ethernet port to connect the monitor unit to your Local Area Network (LAN). This jack has a standard Ethernet pin configuration scheme, twisted pair. Refer to Figure 6.1 for IB5 board location. Refer to Figure 6.6 for Ethernet port location. Use shielded Ethernet cable (grounded at both ends). Note that the IB5 board's RJ-45 jack is connected to chassis ground. Refer to the Monitor Unit Instructions (UM1M832DNA) for operational details.



**NOTE!** IB5 boards with a 10M/100M/1G Ethernet port replaced IB4 boards with a 10M/100M Ethernet port. This transition enables the support of connected devices that communicate up to 1G. While both boards are physically interchangeable, the IB5 board does require the NCU to have V1.2.80 or higher software loaded.



**WARNING!** The intra-building port(s) of the equipment or subassembly is suitable for connection to intra-building or unexposed wiring or cabling only. The intra-building port(s) of the equipment or subassembly MUST NOT be metallicly connected to the interfaces that connect to the OSP or its wiring. These interfaces are designed for use as intra-building interfaces only (Type 2 or Type 4 ports as described in GR-1089-CORE, Issue 4) and require isolation from the exposed OSP cabling. The addition of Primary Protectors is not sufficient protection in order to connect these interfaces metallicly to OSP wiring.

The intra-building port (RJ-45) of the equipment or subassembly must use shielded intra-building cabling/wiring that is grounded at both ends.

#### Default IB5 Ethernet Port Parameters

##### IPv4

IP Address: 192.168.1.2  
Subnet Mask: 255.255.255.0  
Default Gateway: 192.168.1.1

##### IPv6

IPv6 Address: 20fa:fffd:fffc:fffb:fffa:fff9:fff8:fff7  
IPv6 Prefix: 0  
IPv6 Gateway: 20fa:1:ffff:ffff:ffff:ffff:ffff:ffff

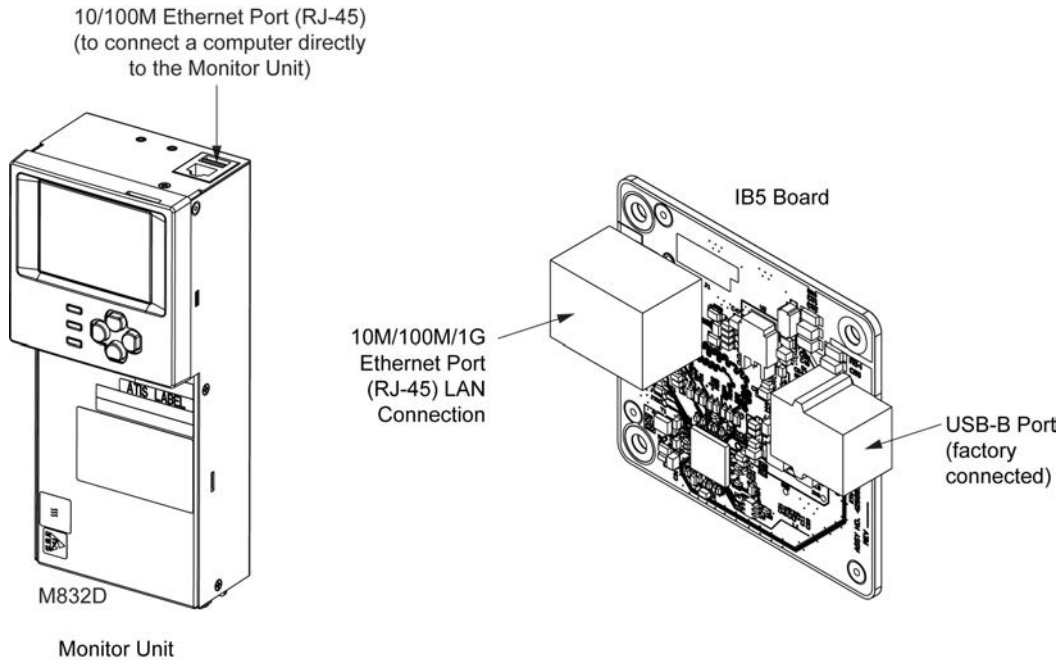
**Figure 6.6 System Ethernet Ports**

## 6.7 Installing and Wiring to an Optional Transient Voltage Surge Suppressor (TVSS) Device

Transient Voltage Surge Suppressor (TVSS) devices are installed in the 'distribution device' mounting positions of a List 15, List 15A, List 25, and List 25A distribution panel only.

When required, all unparalleled distribution panels require a TVSS device. Only one (1) TVSS device is required per paralleled groups of distribution panels.

Unless otherwise specified, install the TVSS device in the mounting position closest to the distribution panel's input busbar.

Refer to SAG582140600 for more information.



**CAUTION!** The TVSS device occupies two mounting positions. Leave an additional empty mounting position between the TVSS device and any overcurrent protective device.

### **Procedure**

1. Install the TVSS device(s) as required. Refer to Figure 6.7.
2. Connect a customer provided cable from the List 15, List 15A, List 25, or List 25A distribution panel lug mounting busbar associated to the TVSS mounting position into a customer's grounding network. Refer to Figure 6.7. Wire to be sized so that the maximum wire resistance is less than 0.550 milliohms.



**NOTE!** The ground cable will be installed in a position normally used for -48V distribution. It is recommended to use a Green cable and insulate the connection with shrink tubing to avoid incidental contact.

**Figure 6.7 Installation and Wiring of Transient Voltage Surge Suppressor (TVSS) Devices**

**DANGER**

**Ensure leads are connected to proper polarity for the device installed, either a distribution device (load lead connection) or a TVSS device (ground connection).**

Load Lead Connections (-48V) and TVSS Lead Connections (+Ground)  
 1/4-20 Studs on 0.625 Centers  
 (Torque to 60 in-lbs)  
 Maximum Lug Width, 0.610 Inches

List 15, List 15A, List 25,  
 and List 25A Distribution Panel

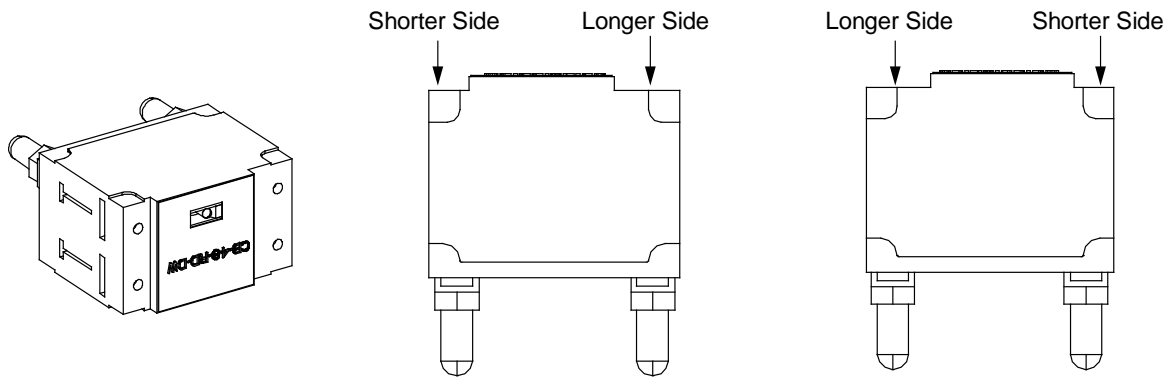
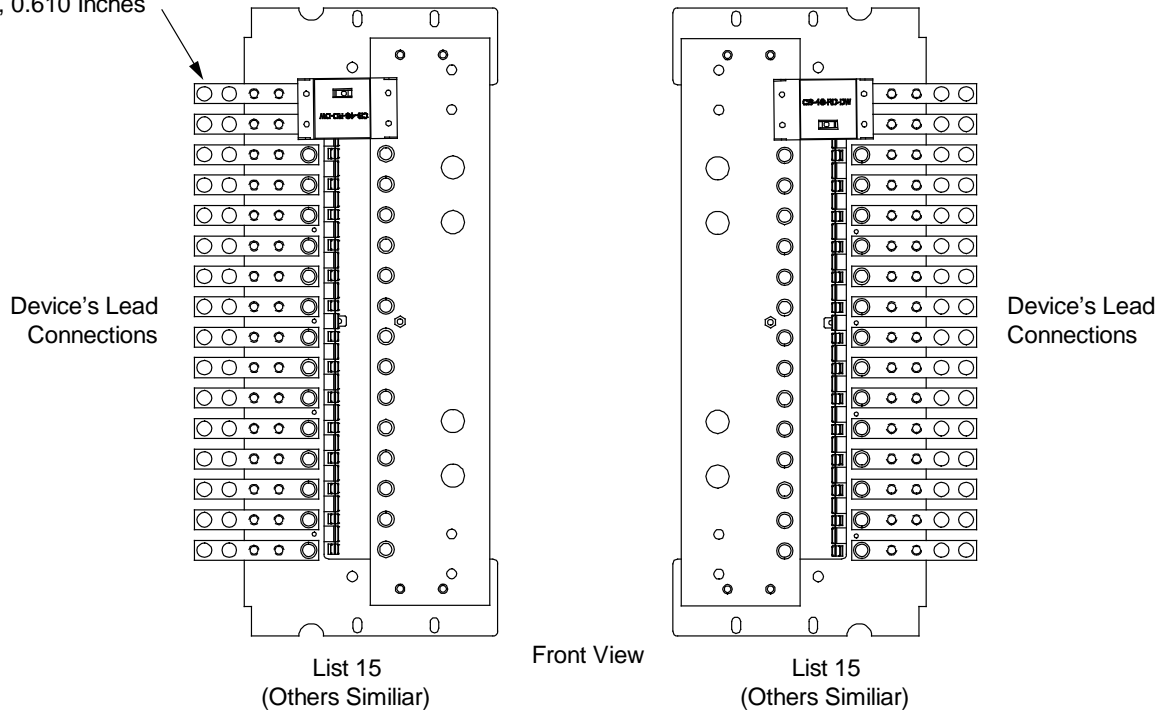

Install TVSS Device so Shorter Side is Towards the Device's Lead Connection Points

## 6.8 Input/Output Cable Routing and Cable Management

### **Input/Output Cable Routing Diagram**

Refer to Figure 6.8 for an input/output cable routing diagram.

Fuseholder and circuit breaker wiring should start with positions furthest from the point that distribution cabling leaves the bay.

It is recommended to wire the loads for top feed arrangements starting with the bottom most distribution position of the bottom most distribution panel and ending with the top most distribution position of the top most distribution panel, and routing the wires starting from the back of the bay and ending with the front of the bay (Bottom to Top, Rear to Front Wiring). For bottom feed bay arrangements, recommended wiring should start with the top most distribution position of the top most distribution panel and ending with the bottom most distribution position of the bottom most distribution panel, and routing the wires starting from the back of the bay and ending with the front of the bay (Top to Bottom, Rear to Front Wiring). It is also recommended as you run your wires to bundle about four wires together with cable lacing, and route each bundle up to the top (or down to the bottom) of the bay, pressing each bundle towards the rear of the bay. When each bundle is pressed as far back as it can go, secure the bundle to the cable dressing bars with cable lacing. Proceed with the next bundle of wires until all distribution positions are wired.

### **Optional Cable Dressing Bar**

Optional cable dressing bars are available. See SAG582140600. The dressing bars are adjustable and allow customer to dress output load cables along the sides of the bay. See Figure 6.9.

### **Optional Load Distribution Cable Management Kit**

An optional load distribution cable management kit is available. See SAG582140600. This kit provides twelve (12) cable separators plus cable ties as a method to manage wiring. This kit cannot be used with the optional cable dressing bars. See Figure 6.10.

**Figure 6.8 Input/Output Cable Routing**

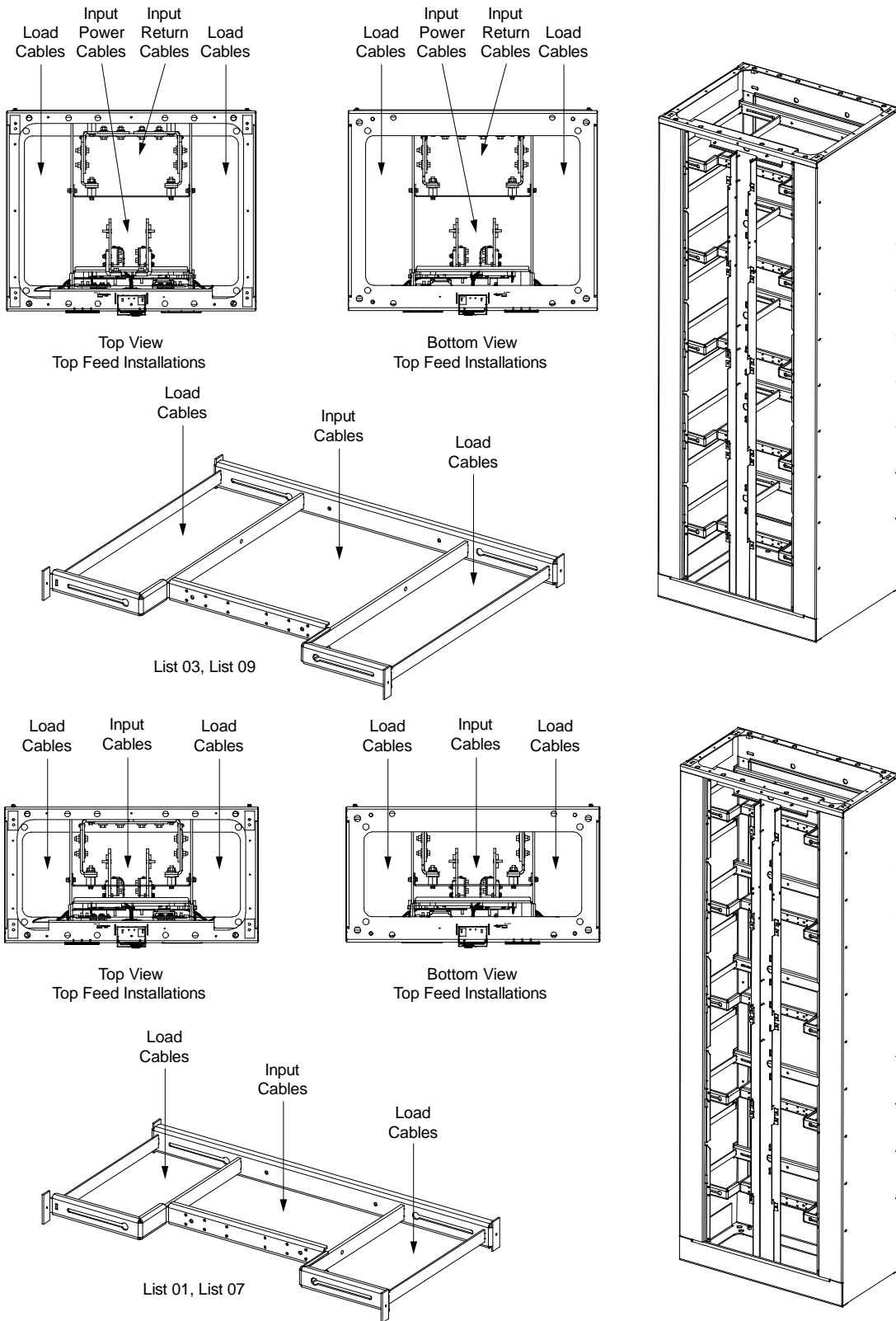
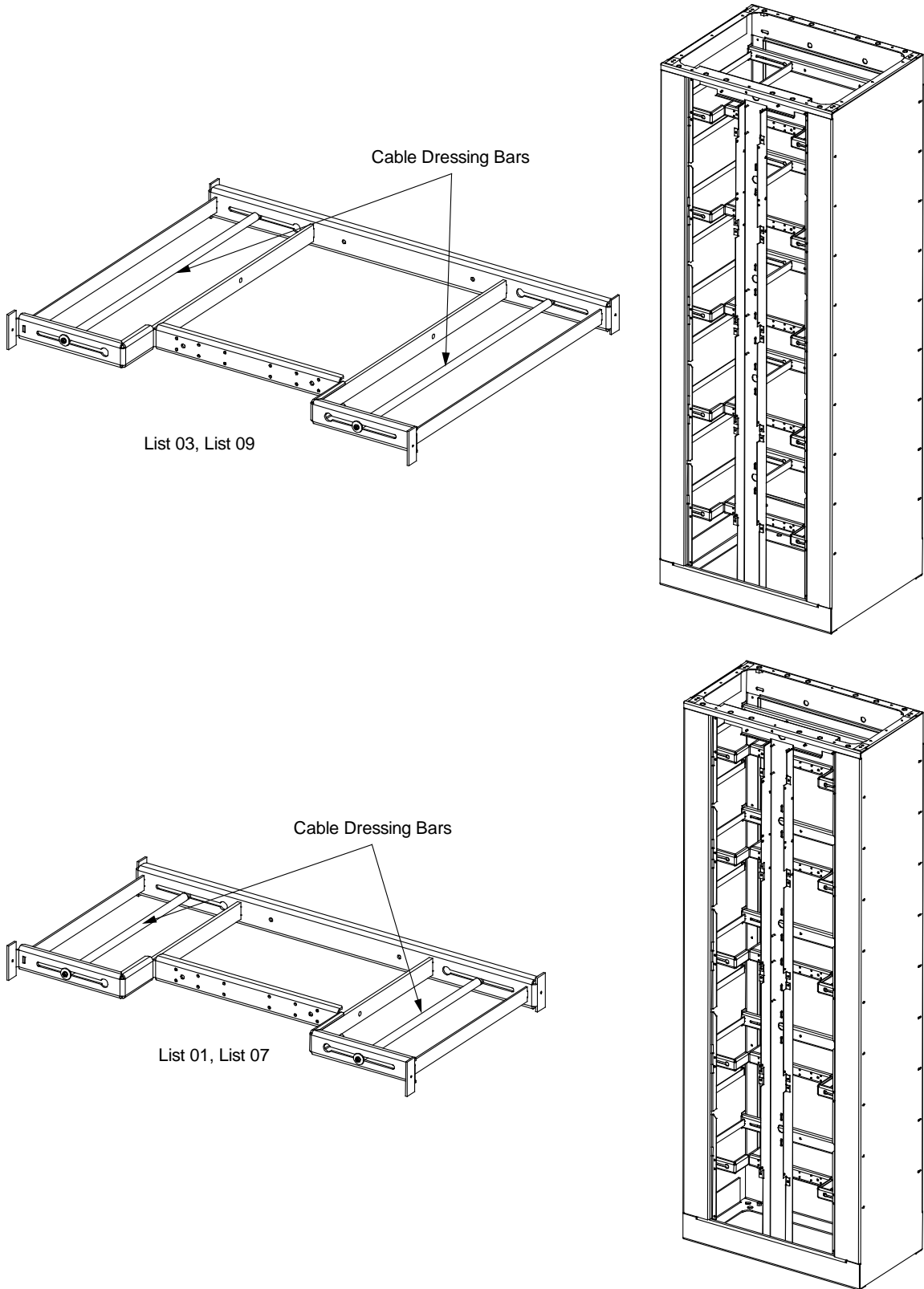
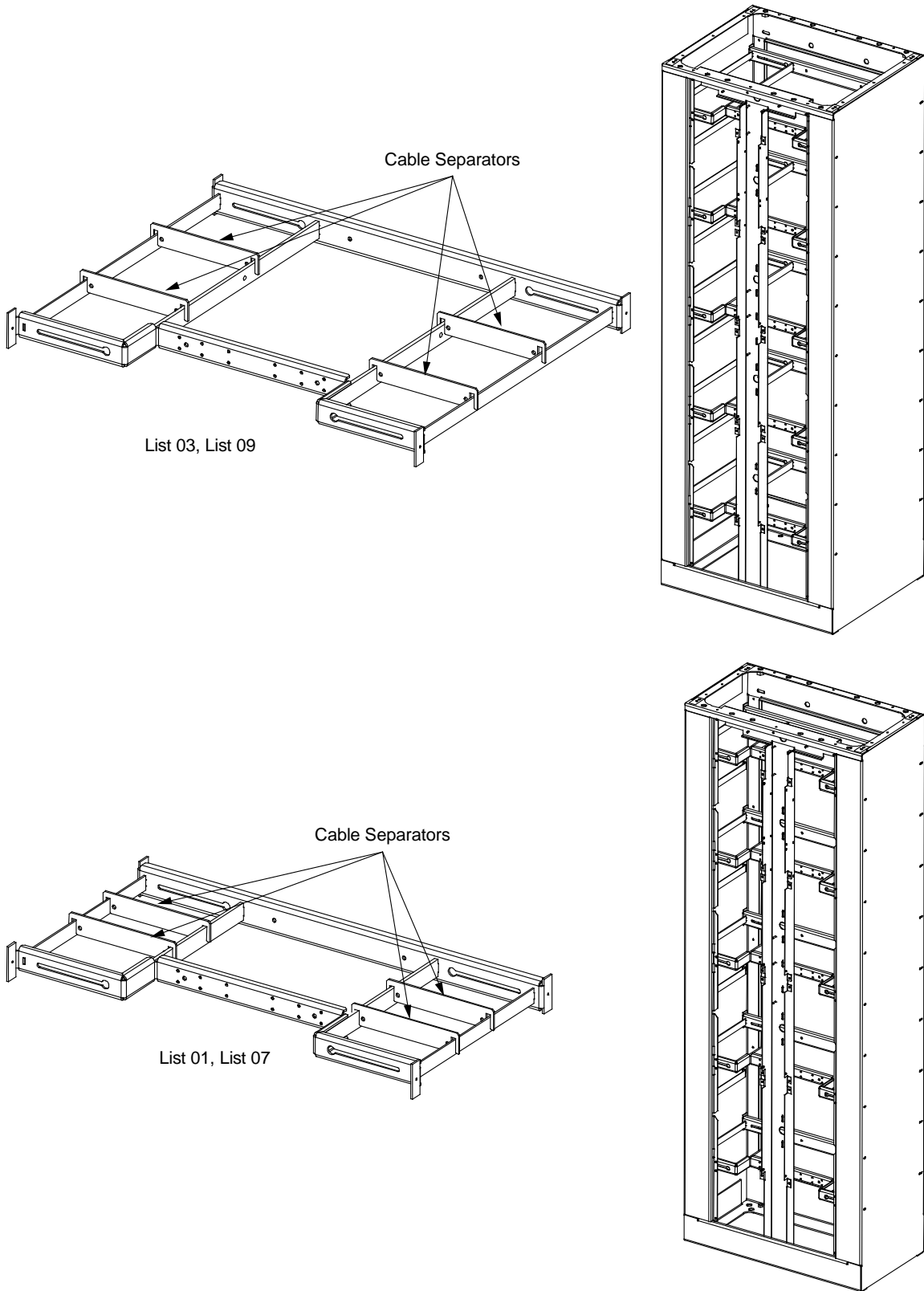

Figure 6.9 Optional Cable Dressing Bars



**Figure 6.10** Optional Load Distribution Cable Management Kit



## 6.9 Load Distribution Connections



**WARNING!** Observe proper polarity when making load connections.



**NOTE!** Refer to “Wiring Considerations” on page 23.

The rating of the distribution device determines the wire size requirements. Refer to the American National Standards Institute (ANSI) approved National Fire Protection Association's (NFPA) National Electrical Code (NEC) and applicable local codes.

### **To Distribution Panels**

Load distribution (load side) leads terminated in the appropriate lug are connected to the “load side” terminations provided on each distribution panel. See Figure 6.11. Torque connections as shown in Figure 6.11.

Load distribution (return side) leads terminated in the appropriate lug are connected to the “load return side” terminations provided on the optional internal ground/return bars or to external ground/return bars. See Figure 6.11. Torque connections as shown in Figure 6.11.

**Figure 6.11 Load Distribution Connections (cont'd on next page)**

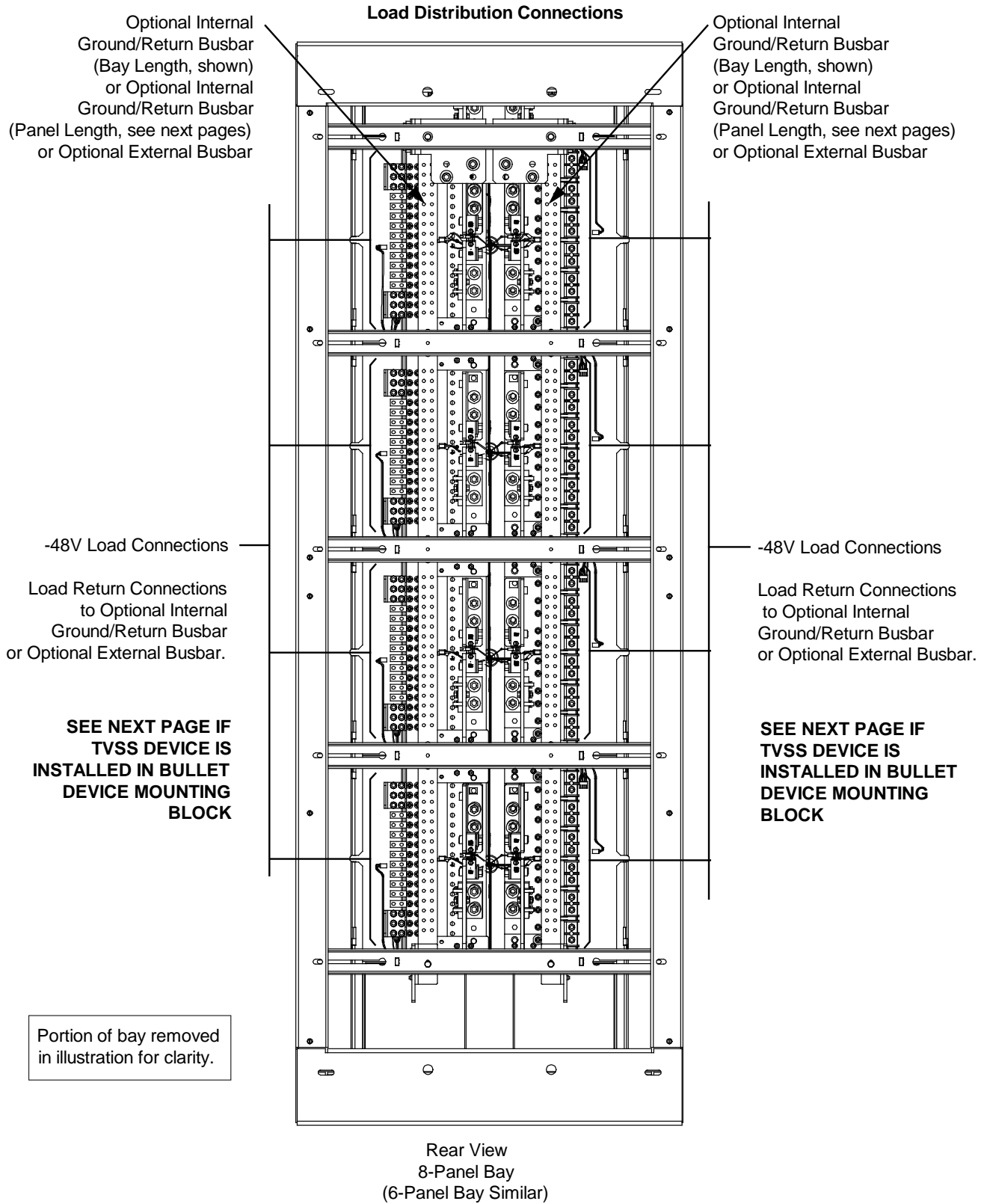

Figure 6.11 Load Distribution Connections (cont'd from previous page, cont'd on next page)

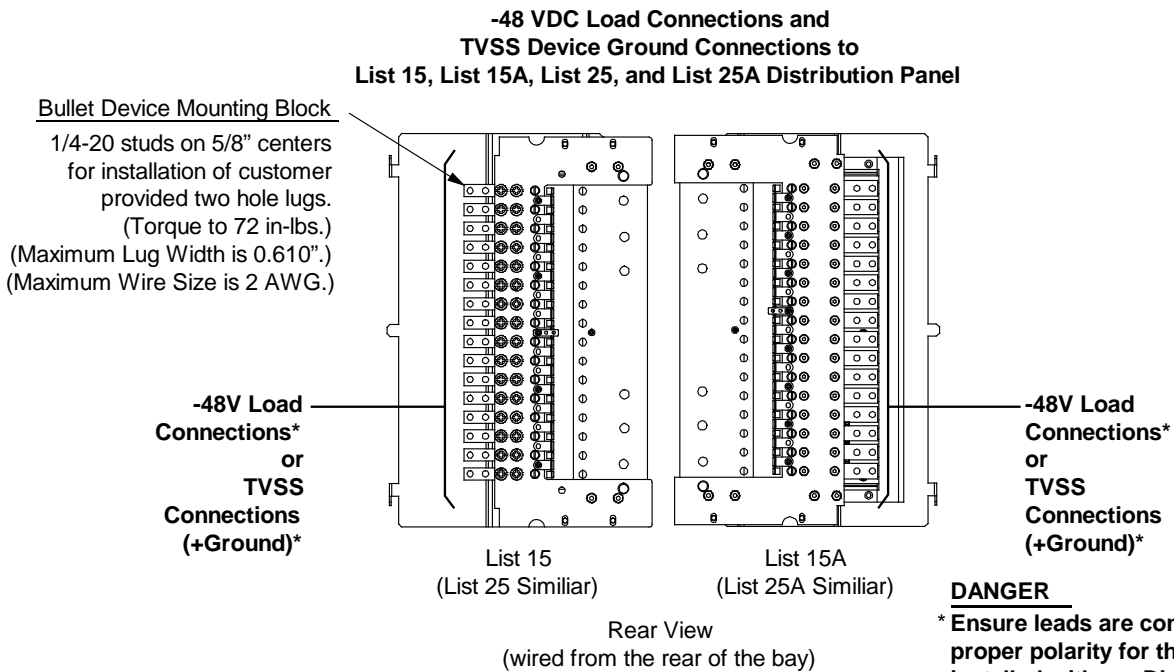
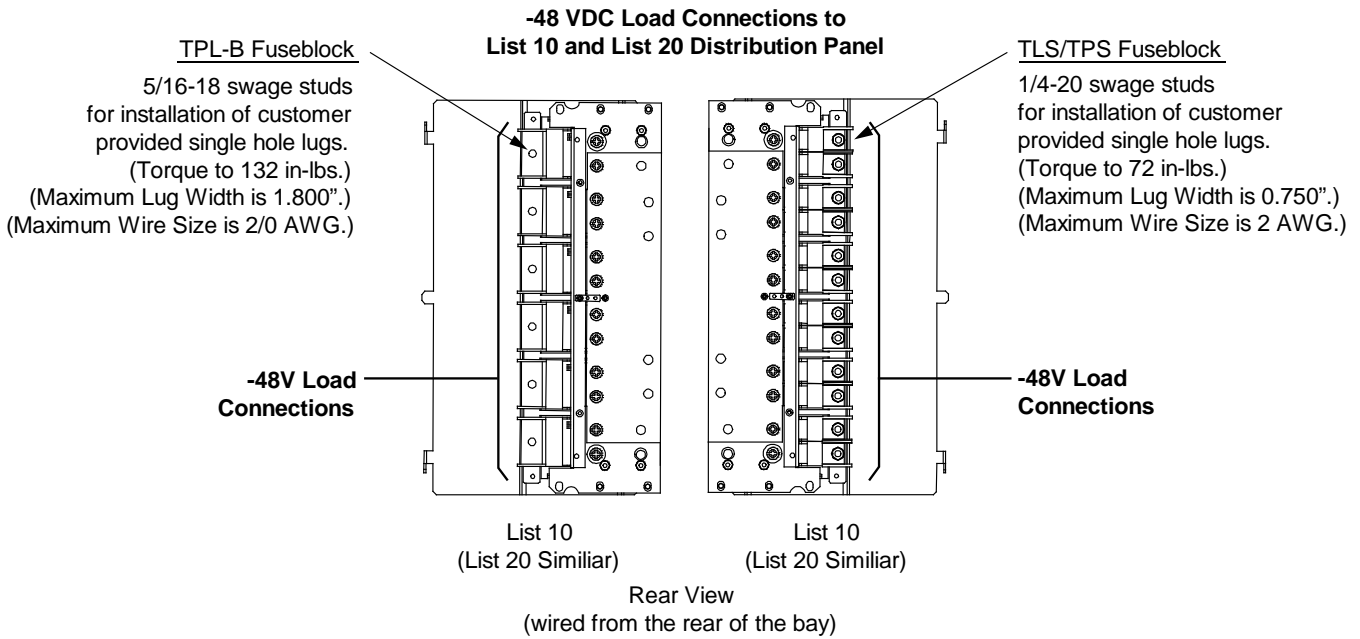

Figure 6.11 Load Distribution Connections (cont'd from previous page, cont'd on next page)

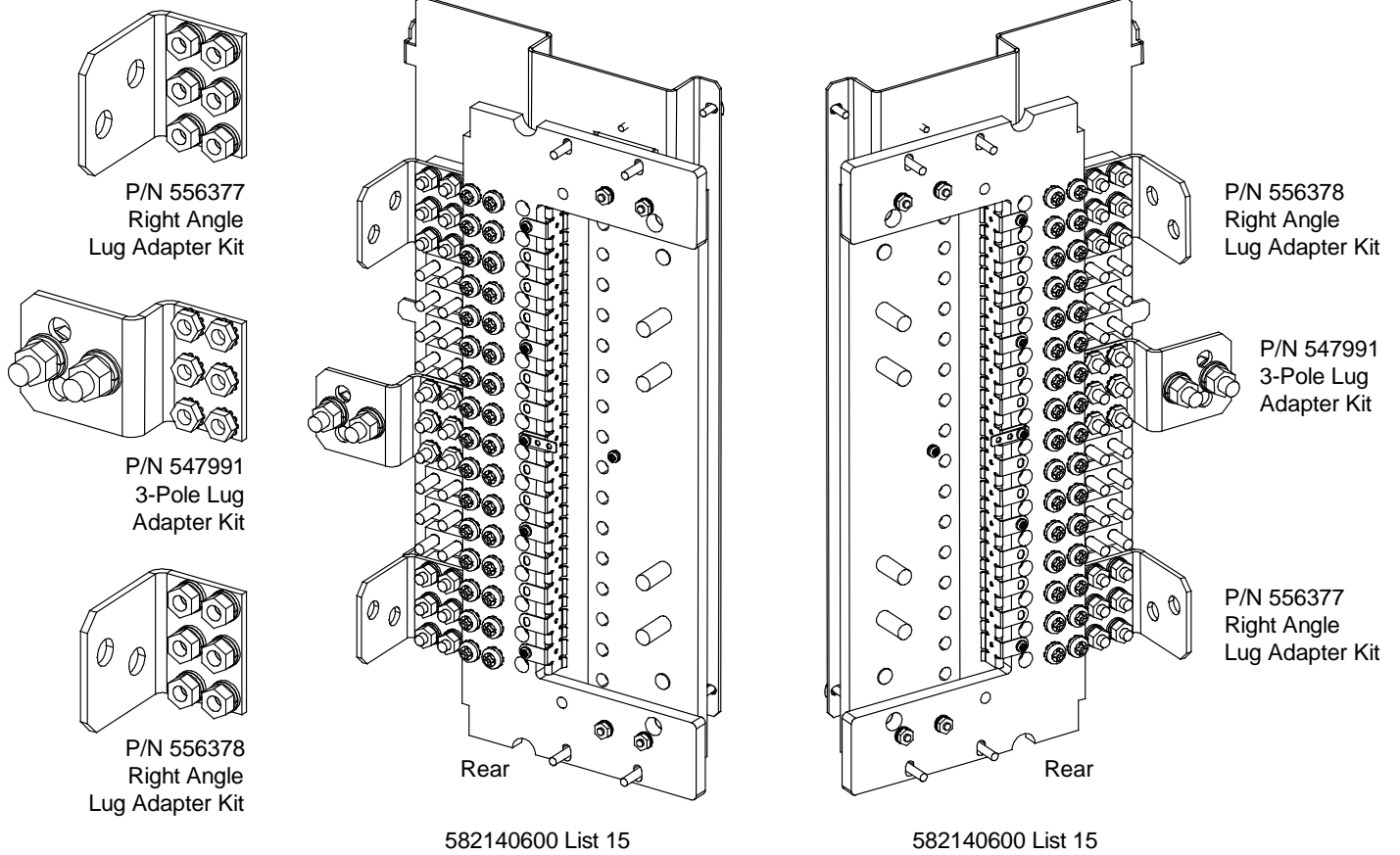

Figure 6.11 Load Distribution Connections (cont'd from previous page, cont'd on next page)

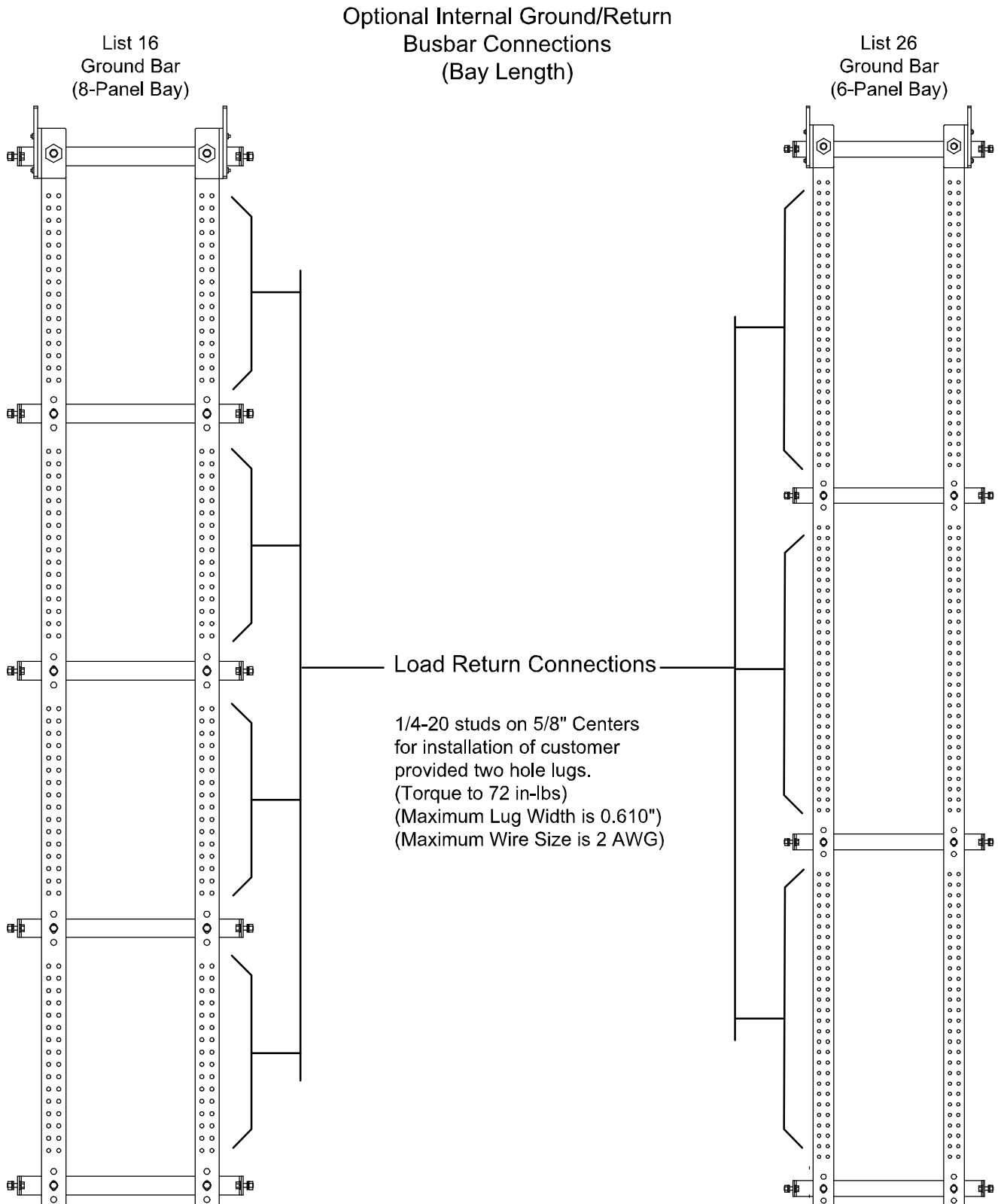
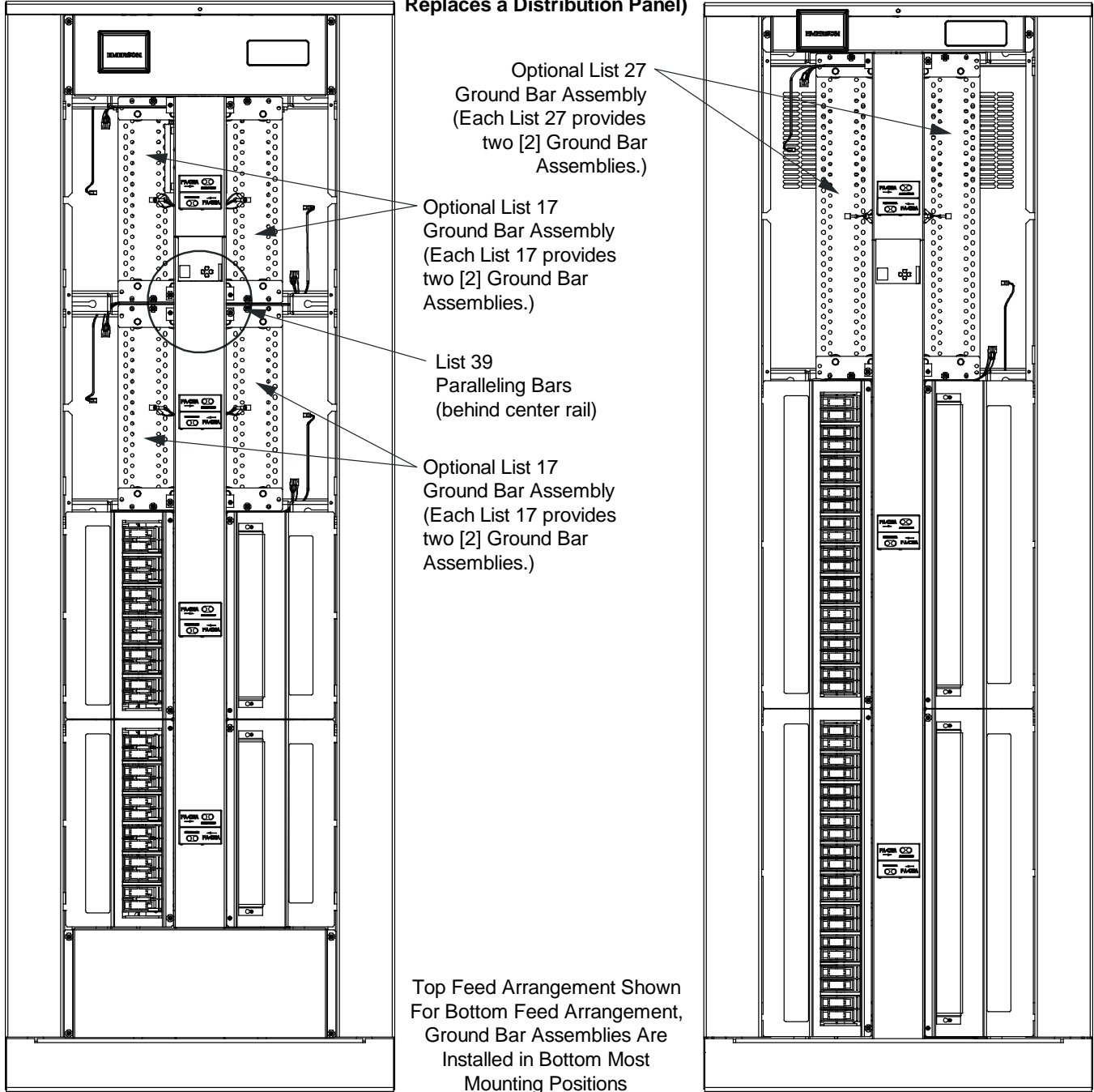

Figure 6.11 Load Distribution Connections (cont'd from previous page, cont'd on next page)

**Optional Internal  
Ground/Return Busbar  
Connections  
(Distribution Panel Length,  
Replaces a Distribution Panel)**



Front View  
8-Panel Bay

Front View  
6-Panel Bay

Figure 6.11 Load Distribution Connections (cont'd from previous page, cont'd on next page)

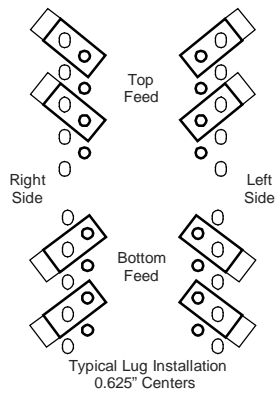
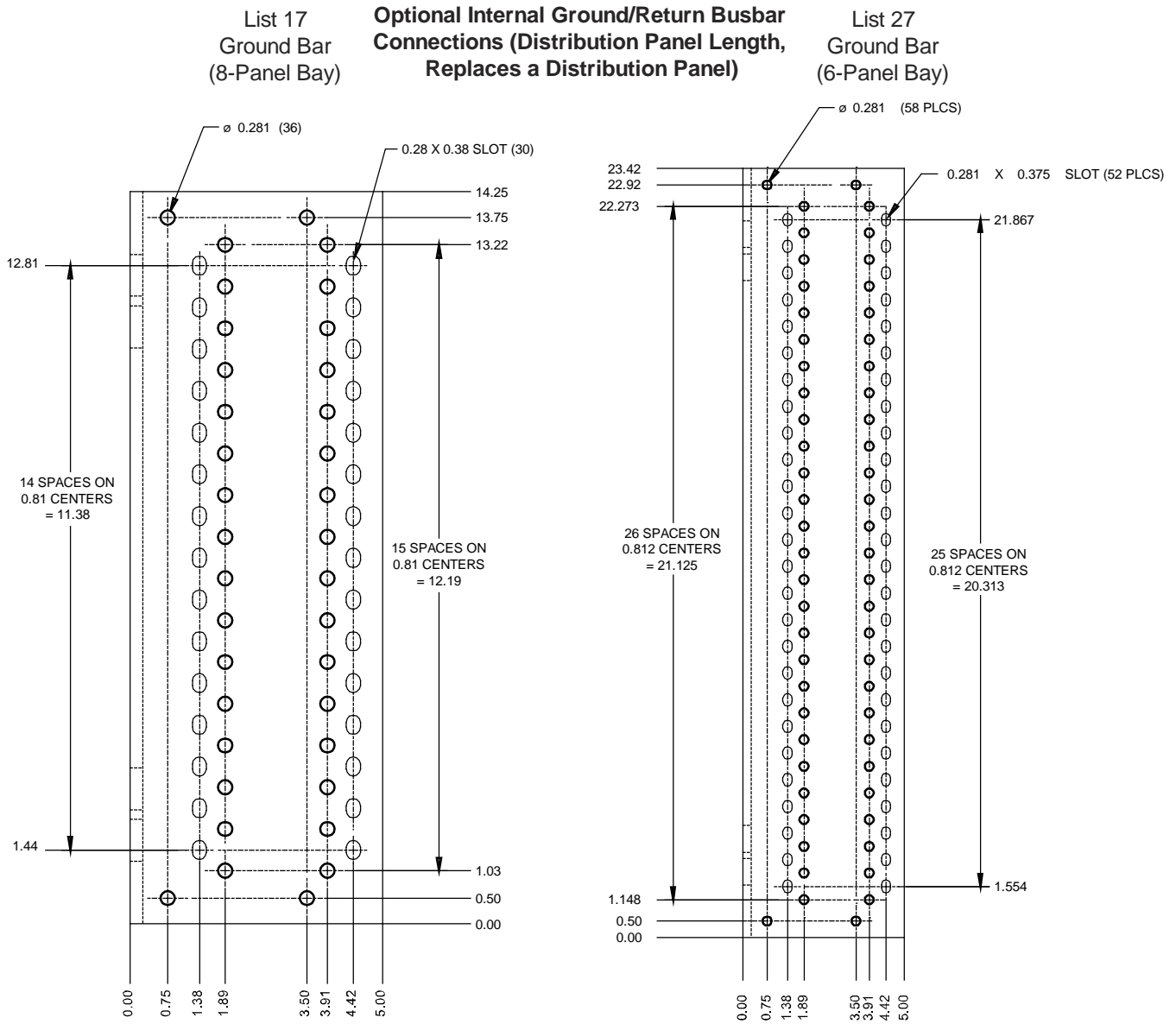

**Load Return Connections**

1/4" clearance holes/slots on 5/8" centers for installation of customer provided two hole lugs.  
 (Torque to 72 in-lbs.)  
 (Maximum Lug Width is 0.610".)  
 (Maximum Wire Size is 2 AWG.)

**Figure 6.11 Load Distribution Connections (cont'd from previous page)**

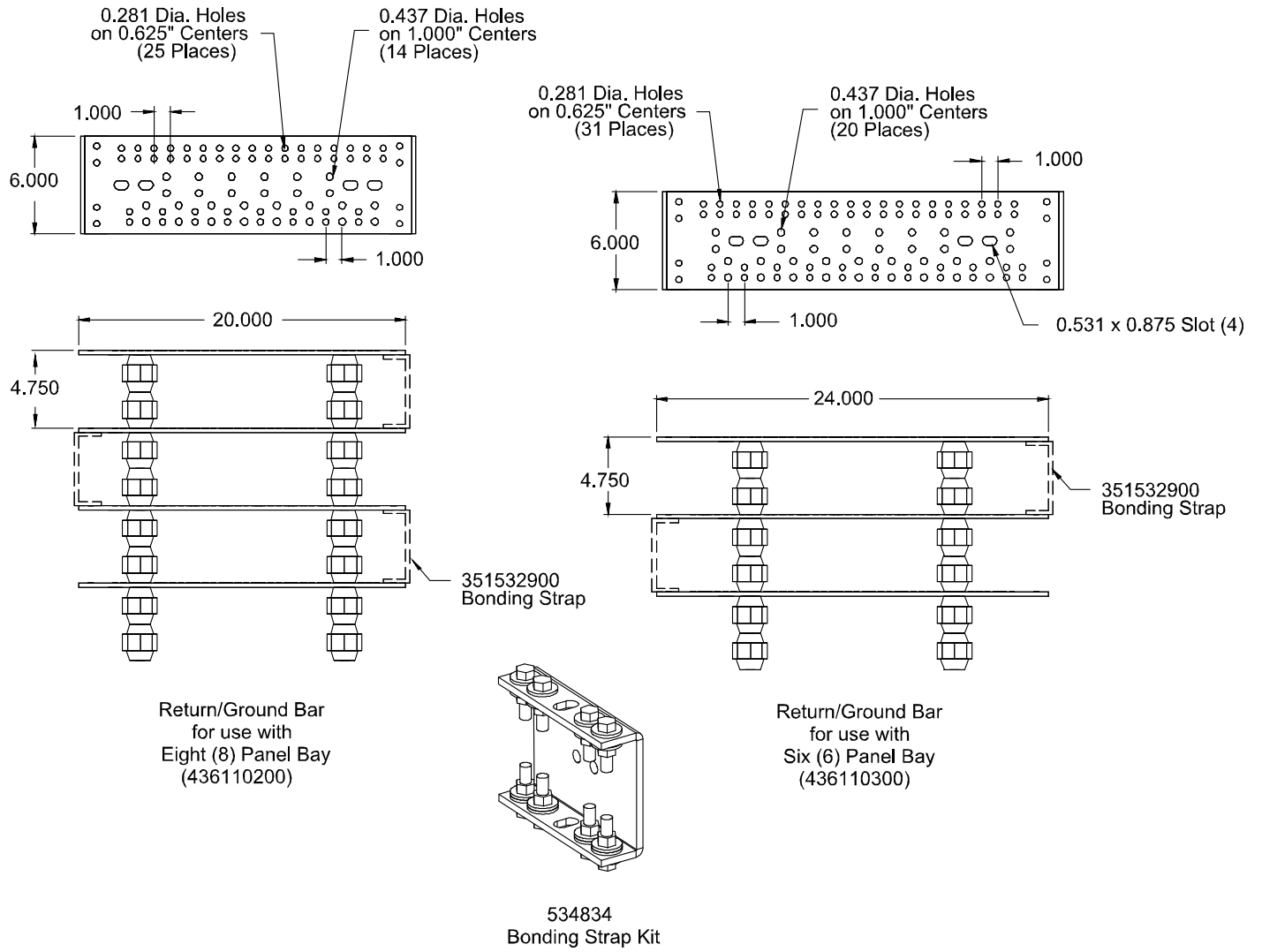

## 6.10 DC Input Connections



**DANGER!** Adhere to the “Important Safety Instructions” presented at the front of this document.



**WARNING!** Observe proper polarity when making battery connections.



**NOTE!** Refer to “Wiring Considerations” on page 23.

DC input wire size varies depending on load. Refer to the American National Standards Institute (ANSI) approved National Fire Protection Association's (NFPA) National Electrical Code (NEC) and applicable local codes.

DC input (-48V) leads terminated in the appropriate lug are connected to the List 43 Input Feed and Shunt Assembly. See Figure 6.12. Torque connections as shown in Figure 6.12.

DC input return leads terminated in the appropriate lug are connected to the optional internal ground/return bars or to external ground/return bars. See Figure 6.12. Torque connections as shown in Figure 6.12.

Figure 6.12 DC Input Connections (cont'd on next page)

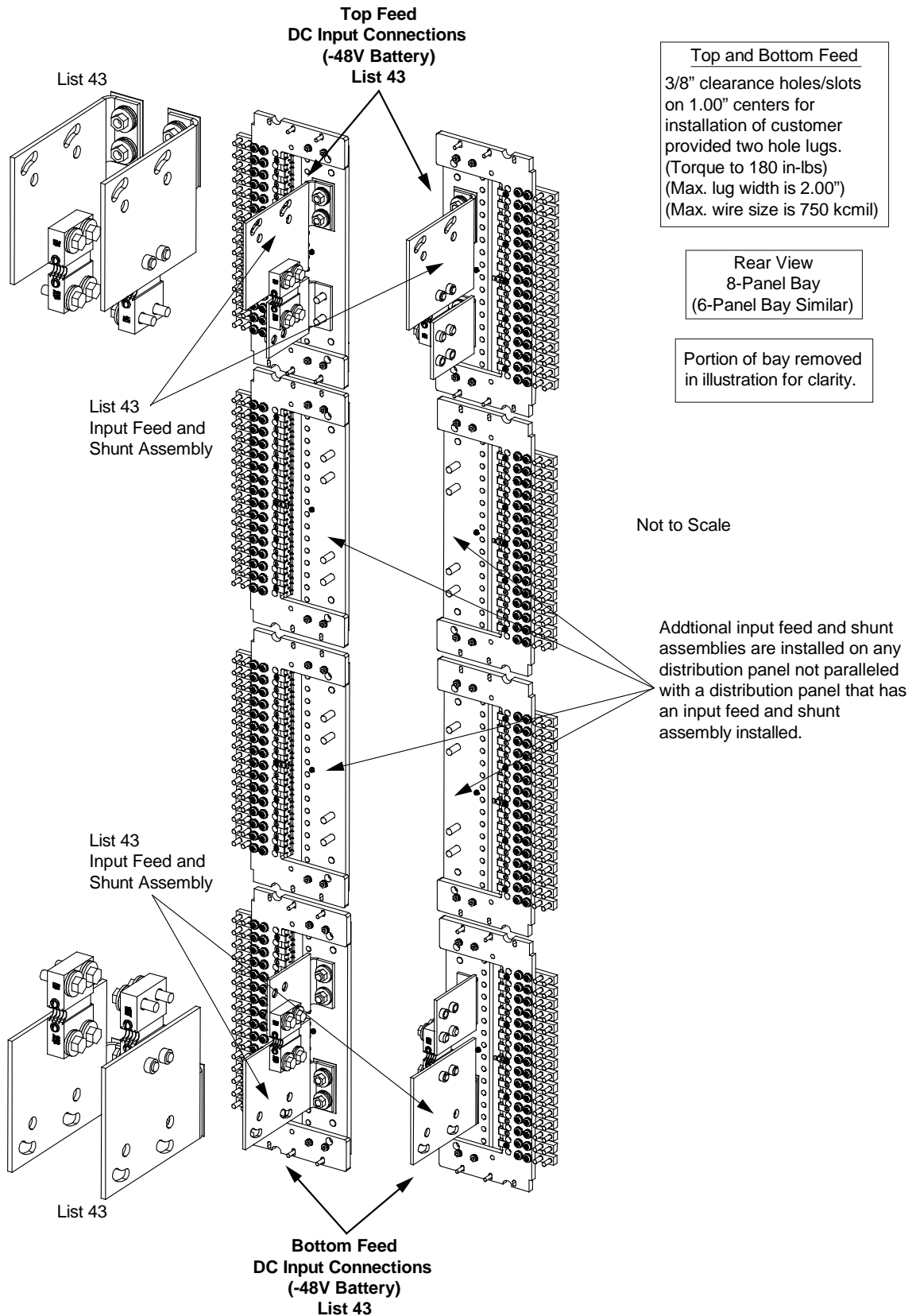

Figure 6.12 DC Input Connections (cont'd from previous page, cont'd on next page)

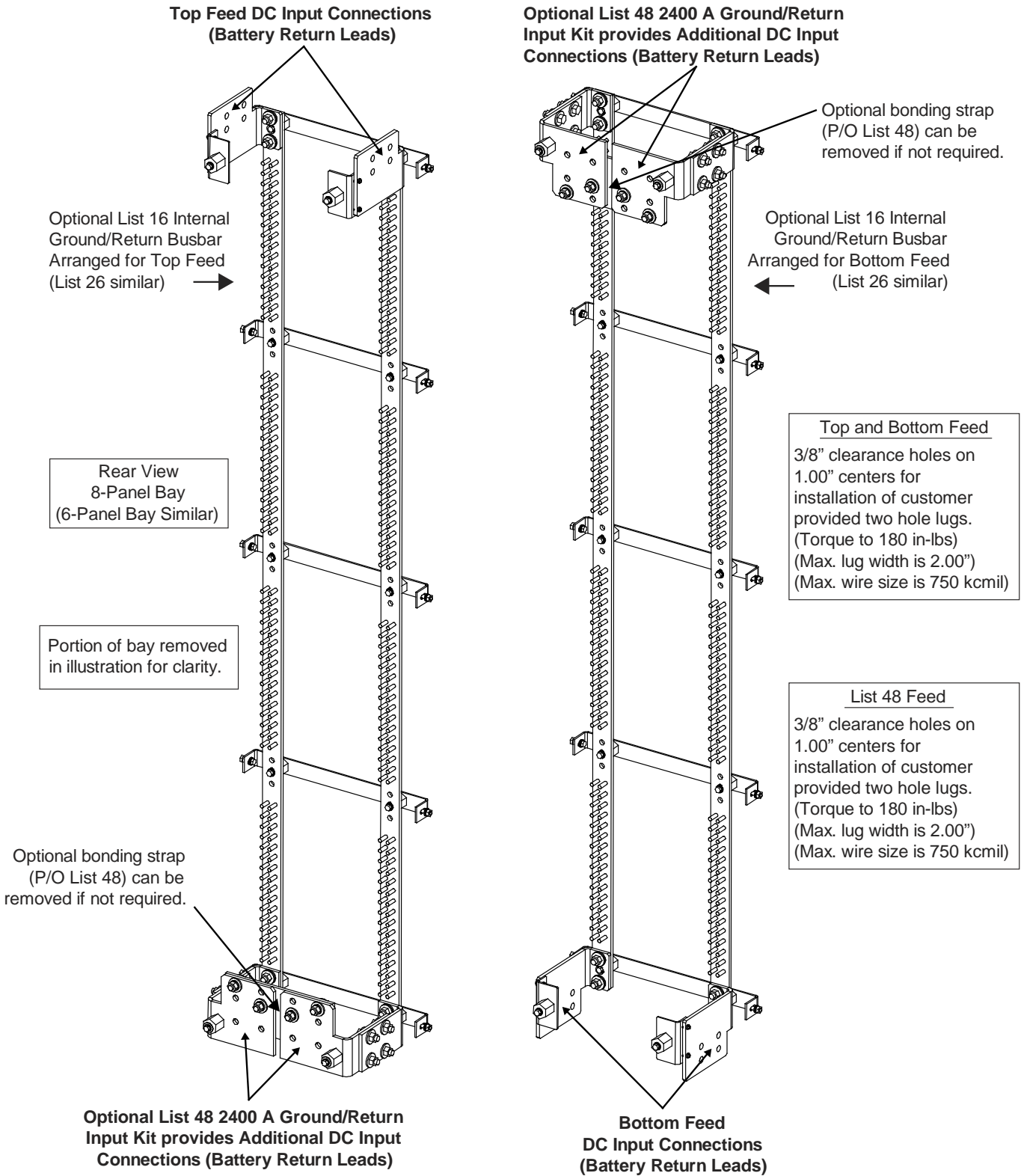
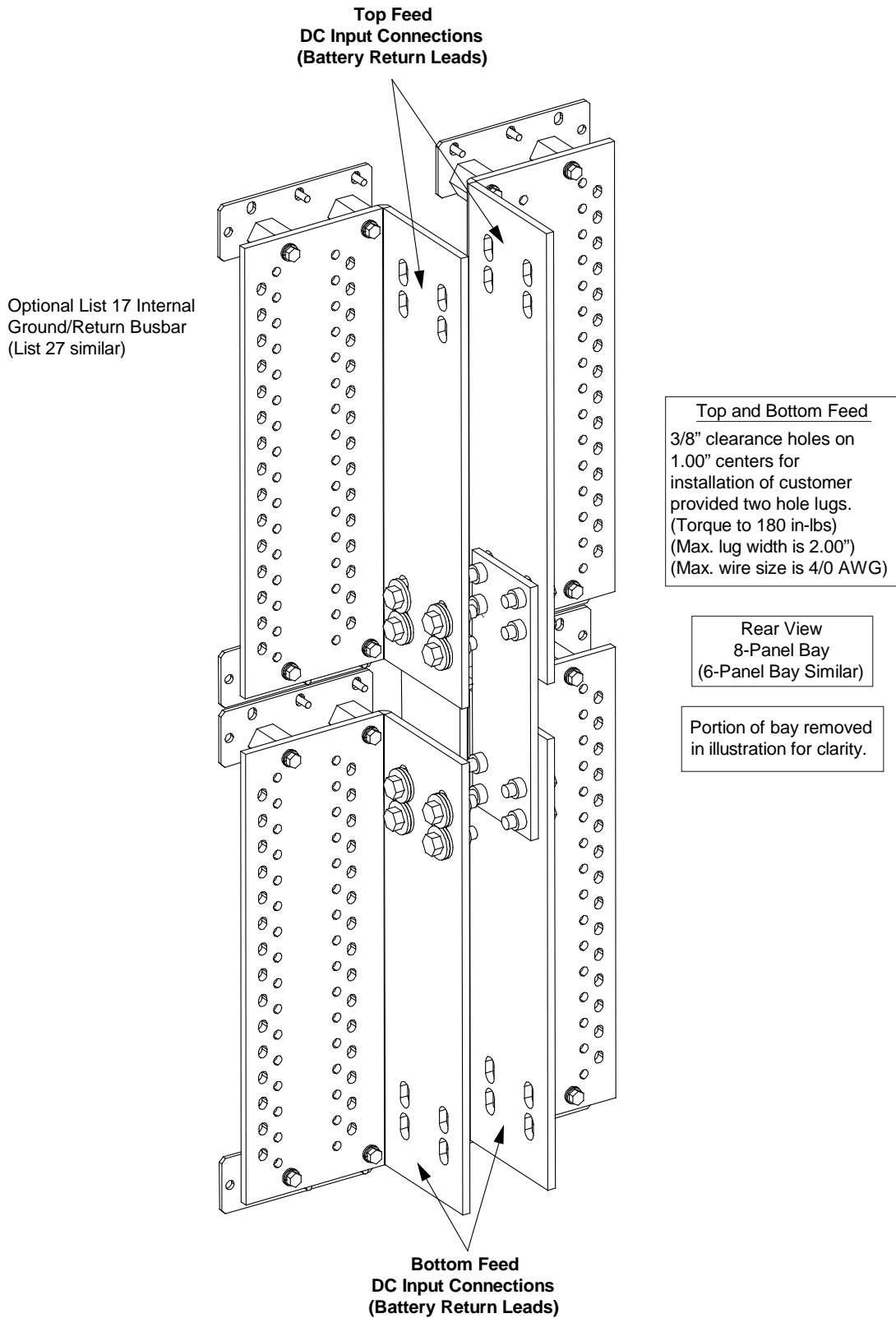
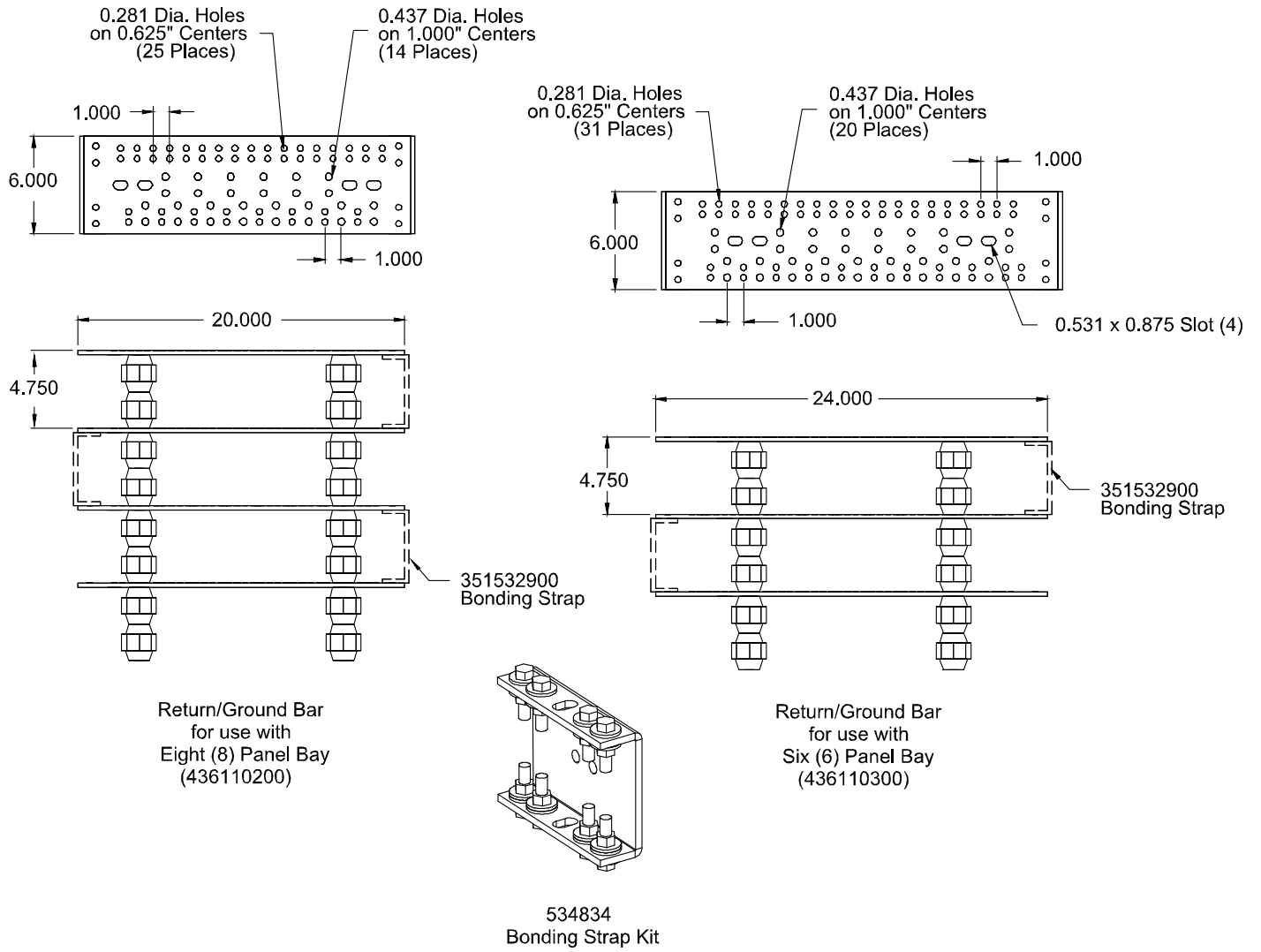

Figure 6.12 DC Input Connections (cont'd from previous page, cont'd on next page)



**Figure 6.12 DC Input Connections (cont'd from previous page)**



## 7 Installing Circuit Breakers and Fuses

Circuit breakers and/or fuses may have been factory installed for you. If so, verify their positions and sizes.

Refer to SAG582140600 for any temperature, sizing, and spacing restrictions.

### **Installing TLS/TPS Fuses into Respective Fuseholders of a List 10 and List 20 Distribution Panel**

Each fuse installs into a pre-mounted fuseholder.

Refer to the following procedure and install appropriately sized TLS/TPS fuses into the proper fuseholders in a List 10 and List 20 distribution panel.

#### **Procedure**



**NOTE!** Refer to Figure 7.1 as this procedure is performed.

1. Remove the fuseholder portion from the mounted fuseholder body by pulling it straight out. Install the TLS/TPS type fuse into the fuseholder. When done, push the fuseholder portion back into the mounted fuseholder body.
2. Ensure an alarm fuse is installed in the GMT fuseholder provided on the mounted fuseholder body. The alarm fuse should be a Bussmann GMT 18/100 ampere alarm fuse (P/N 248610301).
3. Ensure a safety fuse cover is install on the GMT alarm fuse.
4. A spare distribution fuse and alarm fuse may be placed inside the cavity provided on the front of the pull-out fuseholder portion.
5. Record all fuse sizes installed.

**Figure 7.1 Installing TLS/TPS Fuses**

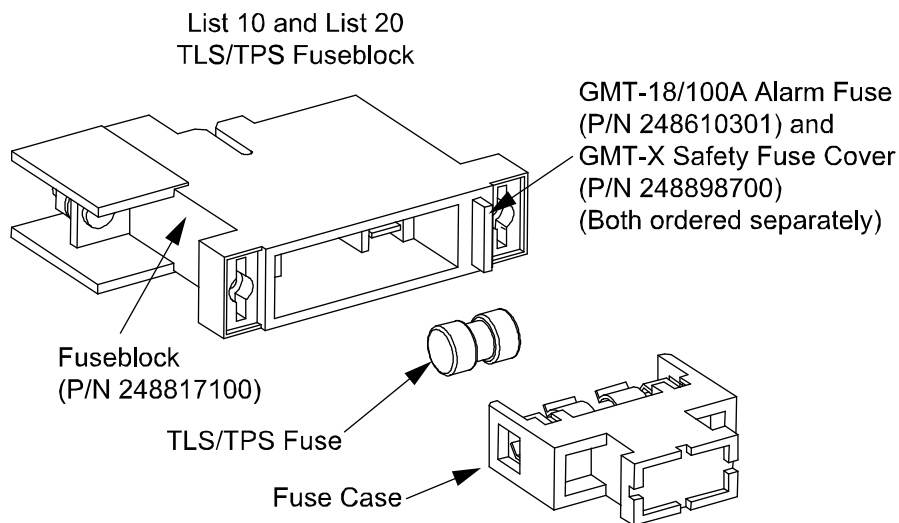

## Installing TPL-B Fuses into Respective Fuseholders of a List 10 and List 20 Distribution Panel

Each fuse installs into a pre-mounted fuseholder.

Refer to the following procedure and install appropriately sized TPL-B fuses into the proper fuseholders in a List 10 and List 20 distribution panel.

### Procedure



**NOTE!** Refer to Figure 7.2 as this procedure is performed.

1. Remove the fuse case from the mounted fuse block by grasping its handle and pulling it straight out.
2. Verify that an 18/100 ampere alarm fuse is present in the GMT-type fuseholder located on the fuse block and that a plastic safety cover is installed on this fuse.
3. Open the fuse case.
4. Install the TPL-B fuse into the fuse case.
5. Close the fuse case.
6. Firmly plug the fuse and fuse case into the fuse block.
7. Record all fuse sizes installed.

**Figure 7.2** Installing TPL Fuses

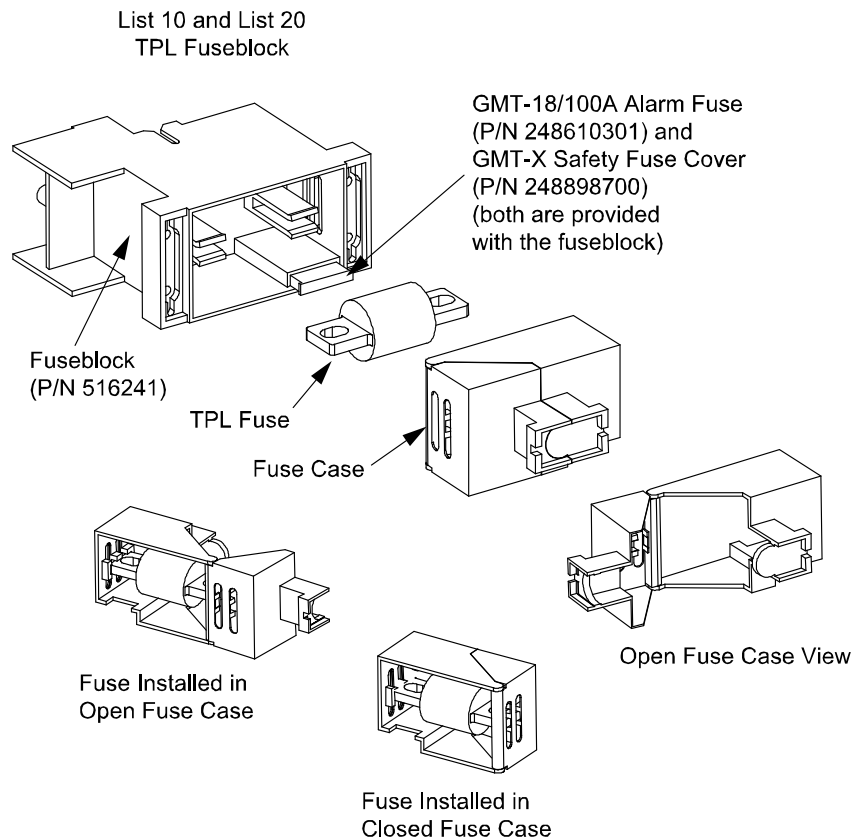

## **Installing Bullet Nose-Type Fuseholders e/w TLS/TPS Fuses in a List 15, List 15A, List 25, and 25A Distribution Panel**

A single fuseholder provides for installation of a 3 to 70 ampere Bussmann TPS-type or a 3 to 125 ampere Littelfuse TLS-type fuse. The fuseholder plugs into a single distribution device mounting position.

Refer to the following procedure and install bullet nose type fuseholders and appropriately sized TPS/TLS fuses into a List 15, List 15A, List 25, and 25A distribution panel.

### **Procedure**



**NOTE!** Refer to Figure 7.3 as this procedure is performed.

1. Orient the fuseholder as shown in Figure 7.3. Insert the terminals on the rear of the fuseholder into their corresponding sockets on the distribution panel. Ensure the alarm contact on the back of the fuseholder makes contact with the alarm terminal on the spring strip. Push fuseholder in firmly until fully seated in the distribution panel.
2. When all fuseholders are installed, install an appropriately sized TPS/TLS fuse in each. To do this, remove the fuse carrier from the mounted fuseholder body. Hold the fuseholder body while you pull the fuse carrier from the body. Slide the fuse in place between the contacts of the fuse carrier. When done, push the fuse carrier back into the fuseholder body. Note that a polarizing key on the bottom of the carrier prevents the carrier from being inserted upside down.
3. Verify that an 18/100 ampere alarm fuse is present in each fuseholder and that a plastic safety cover is installed on this fuse.
4. Record all fuse sizes installed.

## **Installing Bullet Nose Type Circuit Breakers in a List 15, List 15A, List 25, and 25A Distribution Panel**

Each circuit breaker plugs into one, two, or three distribution device mounting position(s).

Refer to the following procedure and install bullet nose type circuit breakers into a List 15, List 15A, List 25, and 25A distribution panel.

### **Procedure**



**NOTE!** Refer to Figure 7.3 as this procedure is performed.

1. Ensure that the circuit breaker is in the OFF position and is of the correct rating. Orient the circuit breaker as shown in Figure 7.3. Insert the terminals on the rear of the circuit breaker into their corresponding sockets on the distribution panel. Ensure the alarm contact on the back of the circuit breaker makes contact with the alarm terminal on the spring strip. Push distribution device in firmly until fully seated in the distribution panel.
2. Record all circuit breaker sizes installed.

**Figure 7.3 Installation of Bullet Nose-Type Circuit Breakers and Fuseholders**

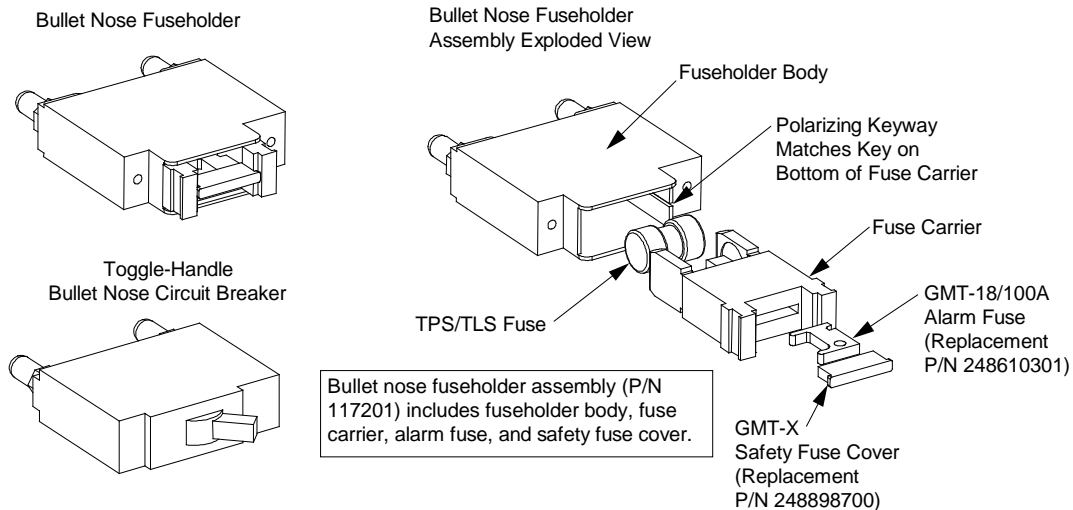
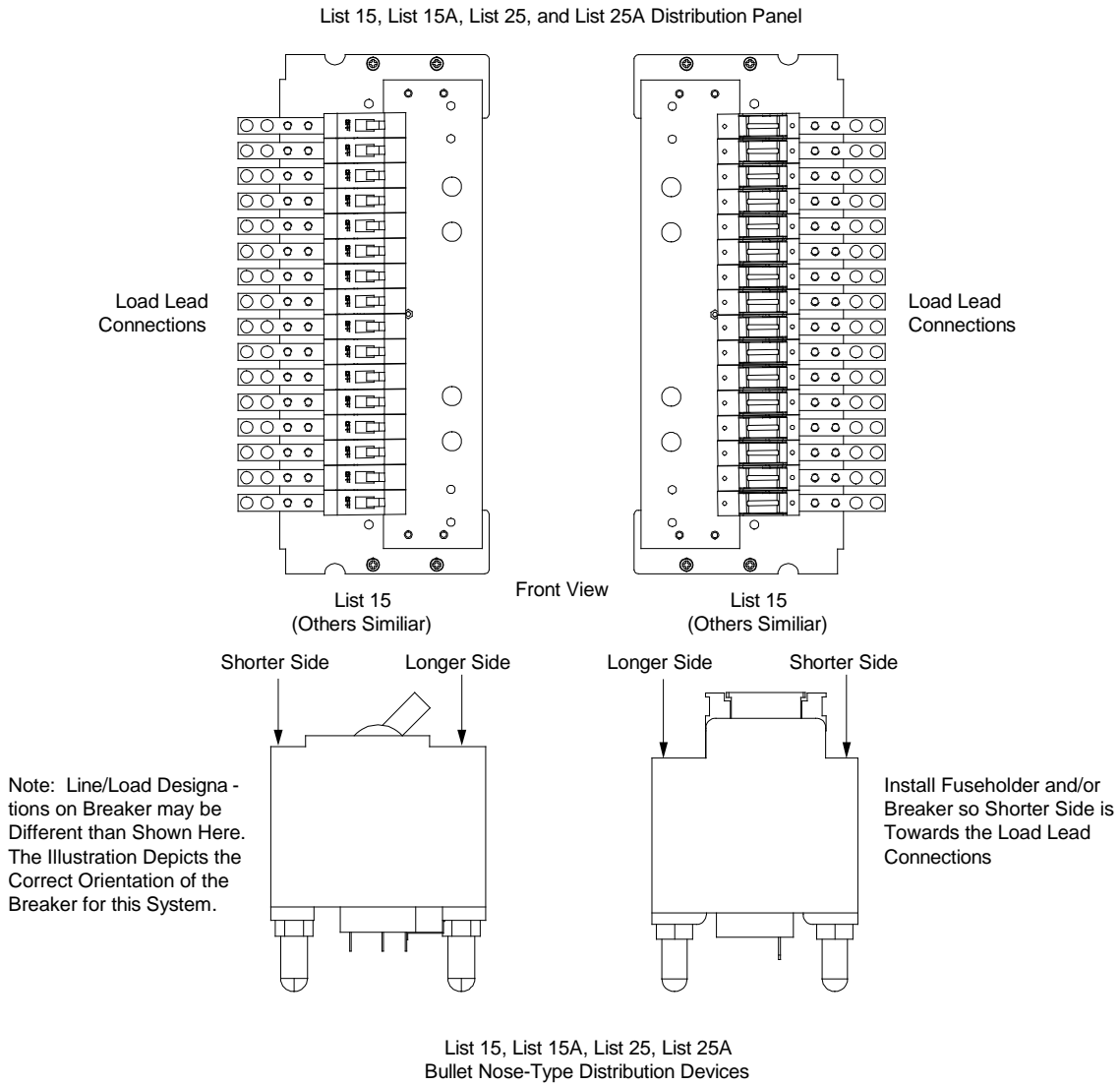

## 8 Initially Starting, Configuring, and Checking System Operation

### 8.1 Important Safety Instructions



**CAUTION!** Performing various steps in the following procedures may cause a service interruption and/or result in the extension of alarms. Notify any appropriate personnel before starting these procedures. Also, notify personnel when these procedures are completed.

### 8.2 Initial Startup Preparation

- Ensure that all blocks, except the last one, in the “Installation Acceptance Checklist” starting on page 3 have been checked.
- Install all distribution devices per “Installing Circuit Breakers and Fuses” starting on page 52. Verify all circuit breakers are in the OFF (O) position.
- Refer to the configuration drawing (C-drawing) supplied with your power system documentation for factory settings of adjustable parameters.

### 8.3 Initially Starting the System

#### Procedure

1. Close the external DC fuse or circuit breaker disconnect device(s) that supply DC input power to the BDF/CBB.
2. Place each distribution circuit breaker (if furnished) to the ON position.

### 8.4 Monitor Unit Initialization

Refer to the Monitor Unit User Instructions (UM1M832DNA) for detailed instructions.

Refer to Figure 8.1 for locations of the monitor unit local indicators and navigation keys.

**Figure 8.1** Monitor Unit Local Indicators and Navigation Keys

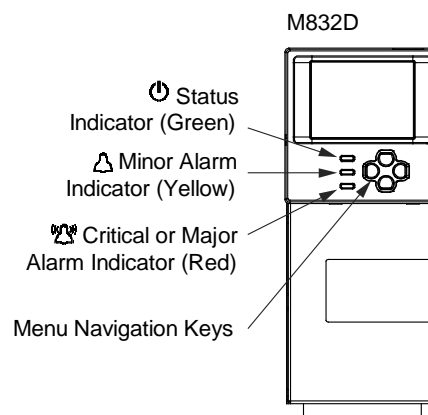

#### Procedure



**NOTE!** The initialization routine takes several minutes. During that time various alarm indicators may illuminate on the monitor unit front panel and an audible alarm may sound. Disregard all alarms. An audible alarm can be silenced at any time by momentarily depressing the **ENT** key on the monitor unit.

1. After the monitor unit is powered on, the monitor unit initializes.
2. When initialization is complete, the language screen appears. Press the up or down arrow key to select the desired language. Press the ENT key to confirm the selection.
3. The Main Menu displays. See Figure 8.2.
4. System information is displayed in multiple screens. If desired, press the ESC key to view other system information. Press the down arrow key to view the next screen. Press the ESC key to return to the Main Menu.
5. From the Main Menu (see Figure 8.2), press the UP and DOWN keys to highlight the desired Menu graphic in the Main Menu. Press the ENT key to enter the selected menu.



**NOTE!** Repeatedly press the “ESC” key to return in reverse order level by level from any submenu until the Main Menu appears.

6. Refer to the following procedures to verify and set the monitor unit as required for your application.

**Figure 8.2 Monitor Unit Local Display Main Menu**

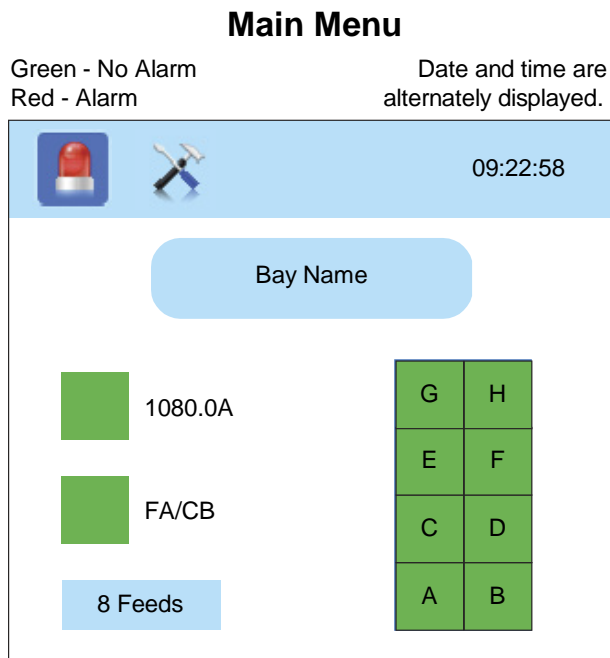

If any of the green fields are red in your system, it indicates an alarm condition exists.

Graphics	Menu Name	Description
	Alarm (Green - No Alarm) (Red - Alarm)	View active alarms and alarm history.
	Settings	Gain access to the Monitor Unit's settings menus.
	Bay Current	View bay current graphs.
	Input Feeds Current and Voltage	View current and voltage graphs for bay's input feeds.
	Distribution Panels	View selected distribution panel status.

Press the UP and DOWN keys to highlight the desired Menu graphic in the Main Menu.

Press the ENT key to enter the selected menu.

## 8.5 Verifying and Setting the Monitor Unit as Required for Your Application

Refer to the Monitor Unit Instructions (UM1M832DNA) for additional information.

Note that you will have to program the monitor unit for any external inputs/outputs connected to the IB2 Interface Board.

### **Verifying the Configuration File**

Your system was programmed with a configuration file that sets all adjustable parameters. The version number of the configuration file can be found on the configuration drawing (C-drawing) that is supplied with your power system documentation. You can verify that the correct configuration file has been loaded into your monitor unit by performing the following procedure.

#### **Procedure**

1. With the Main Menu displayed, press ESC. A screen displays the monitor unit's name, serial number, IP number, software version, hardware version, and configuration version number.
2. Press ESC to return to the Main Menu.

### **Checking Basic System Settings**

Navigate through the monitor unit menus and submenus to check system settings. You can adjust any parameter as required. Note that these settings can also be checked (and changed if required) via the WEB Interface.



**NOTE!** Repeatedly press the "ESC" key to return in reverse order level by level from any submenu until the Main Menu appears.

#### **Procedure**

1. **To Select a Sub-Menu:**  
Press the UP and DOWN keys to highlight the desired sub-menu. Press the ENT key to enter the selected sub-menu.
2. **To Select a User:**  
To select a User, use the UP and DOWN keys to move the cursor to the Select User field. Press ENT. Use the UP and DOWN keys to select a User previously programmed into the monitor unit. Press ENT to select the User. Note that only Users programmed into the monitor unit are shown. Users are programmed via the Web Interface. The default User is admin.
3. **To Enter a Password:**  
If a password screen opens, a password must be entered to allow the User to make adjustments. To enter a password, use the UP and DOWN keys to move the cursor to the Enter Password field. Press ENT. Use the UP and DOWN keys to choose a character. Press ENT to accept and move to the next character. Continue this process until all characters are entered. Press ENT again to accept the password. The default password is 640275.
4. **To Change a Parameter:**  
Press the UP and DOWN keys to move up and down the list of parameters. Press ENT to select the parameter. Press the UP and DOWN keys to change the parameter. Press ENT to make the change. Press ESC to cancel the change.
5. Table 8.1 shows the menu navigation for some basic settings. Refer to the separate Monitor Unit Manual (UM1M832DNA) supplied with your system for complete Local Display menus.

**Table 8.1 Monitor Unit Basic Settings Menu Navigation**

Parameter	Menu Navigation
Date	Main Menu / Settings Icon / Sys Settings / Date.
Time	Main Menu / Settings Icon / Sys Settings / Time.
IP Communications Parameters (IP address, subnet mask address, gateway address)	Main Menu / Settings Icon / Comm Settings / enter parameters.

## **Programming Channels for TVSS Devices**

If a TVSS device is installed in an advance panel, program the panel as follows.

### **Procedure**

1. Name the positions occupied by the TVSS device and mark the position as a two-pole device which is not used.

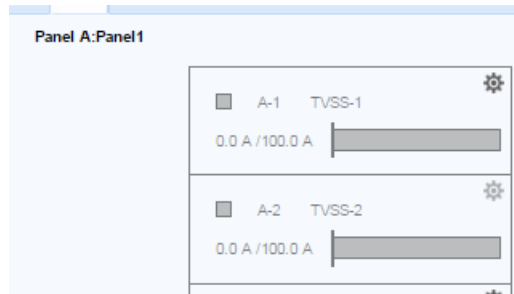

## **Checking Circuit Breaker Alarm / Fuse Alarm**

Perform the following procedure to verify the CBA/FA alarm is operational.



**NOTE!** The following procedure applies only to circuit breakers that provide an alarm indication when manually placed to the OFF (open) position. Electrical trip only circuit breakers cannot be easily tested in the field. Electrical trip only circuit breakers have white handles and electrical/mechanical circuit breakers have black handles.

1. On a distribution panel, remove an alarm-type fuse and replace it with a known open fuse or place a circuit breaker to the OFF (0) position.
  - a) **Requirement:** The major alarm indicator on the monitor unit illuminates red. The monitor unit displays a fuse alarm message with location. The STATUS indicator at the top of the bay illuminates red. If connected and configured, remote CBA/FA alarms activate.
2. Replace the open fuse with a known good fuse or place the circuit breaker to the ON (1) position.
  - a) **Requirement:** The major alarm indicator on the monitor unit extinguishes. The monitor unit displays "System OK". STATUS indicator at the top of the bay extinguishes. If connected and configured, remote CBA/FA alarms retire.
3. Repeat steps 1) and 2) for each alarm-type fuse or circuit breaker on the distribution panel.
4. Repeat steps 1) through 3) for each distribution panel in the system.
5. If not already done, remove the access cover from the top of the bay front. Before removing, note the location of any grounding washers used with the hardware securing the panel. This provides access to the auxiliary fuse card. See Figure 6.4.
6. Remove an alarm-type fuse and replace it with a known open fuse.

- a) **Requirement:** The major alarm indicator on the monitor unit illuminates red. The monitor unit displays a fuse alarm message with location. The STATUS indicator at the top of the bay illuminates red. If connected and configured, remote CBA/FA alarms activate.
- 7. Replace the open fuse with a known good fuse.
  - a) **Requirement:** The major alarm indicator on the monitor unit extinguishes. The monitor unit displays “System OK”. STATUS indicator at the top of the bay extinguishes. If connected and configured, remote CBA/FA alarms retire.
- 8. Repeat steps 6 and 7 for each fuse on the circuit card.

**Checking Monitor Unit Dual Power Source Check (if two power sources connected)**



1. Remove fuse F5 from the auxiliary fuse card. See Figure 6.4 for location. Verify the monitor unit and CBA/FA circuit are functional by performing the checkout procedure above.
2. Replace fuse F5.
3. Remove fuse F6. Verify the monitor unit and CBA/FA circuit are functional by performing the checkout procedure above.
4. Replace fuse F6.
5. Install and secure the access cover over the auxiliary fuse card. Ensure ground washer are installed at the locations noted earlier in the checkout procedure.

**8.6 Checking System Status**

**Procedure**

1. Observe the status of the indicators located on the monitor unit. If the system is operating normally, the status of these is as shown in Table 8.2.
2. Verify that the STATUS indicator at the top of the bay is not illuminated.
3. Verify that all Power Status indicators located on the BDF/CBB's front center channel (one for each distribution panel) are illuminated green.
4. Verify that all FA/CBA alarm indicators located on the BDF/CBB's front center channel (one for each distribution panel) are off.
5. Verify there are no external alarms.

**Table 8.2 Monitor Unit Status and Alarm Indicators**

Indicator		Normal State
	Status (Green)	On
	Minor Alarm (Yellow)	Off
	Critical or Major Alarm (Red)	Off

## 8.7 Final Steps

### **Procedure**

1. If any monitor unit configuration settings were changed, refer to the Monitor Unit Instructions (UM1M832DNA) and save a copy of the configuration file. This file can be used to restore the monitor unit settings, if required, at a later date.

## 9 Operating the System

### 9.1 Monitor Unit

For monitor unit operating instructions, refer to the Monitor Unit User Manual (UM1M832DNA).



**NOTE!** The monitor unit's default "User Name" is "admin" and the default "Password" is "640275".

### 9.2 Local Controls and Indicators

#### **Monitor Unit**

Refer to the separate monitor unit instruction manual.

#### **Bay's Front Center Channel**

The following indicators are located on the BDF/CBB's front center channel. See Figure 9.1.

- a) FA/CBA: This red indicator illuminates when a circuit breaker or fuse opens in the corresponding distribution panel.
- b) POWER STATUS: This green indicator illuminates when DC power is applied to the corresponding distribution panel.

#### **Transient Voltage Surge Suppressor Device (TVSS)**

A TVSS contains an indicator which illuminates when the circuit activates to suppress voltages.

#### **Default Bay Advanced Panel Distribution Device Numbering Scheme**

See Figure 9.2.

Figure 9.1 Bay's Indicators

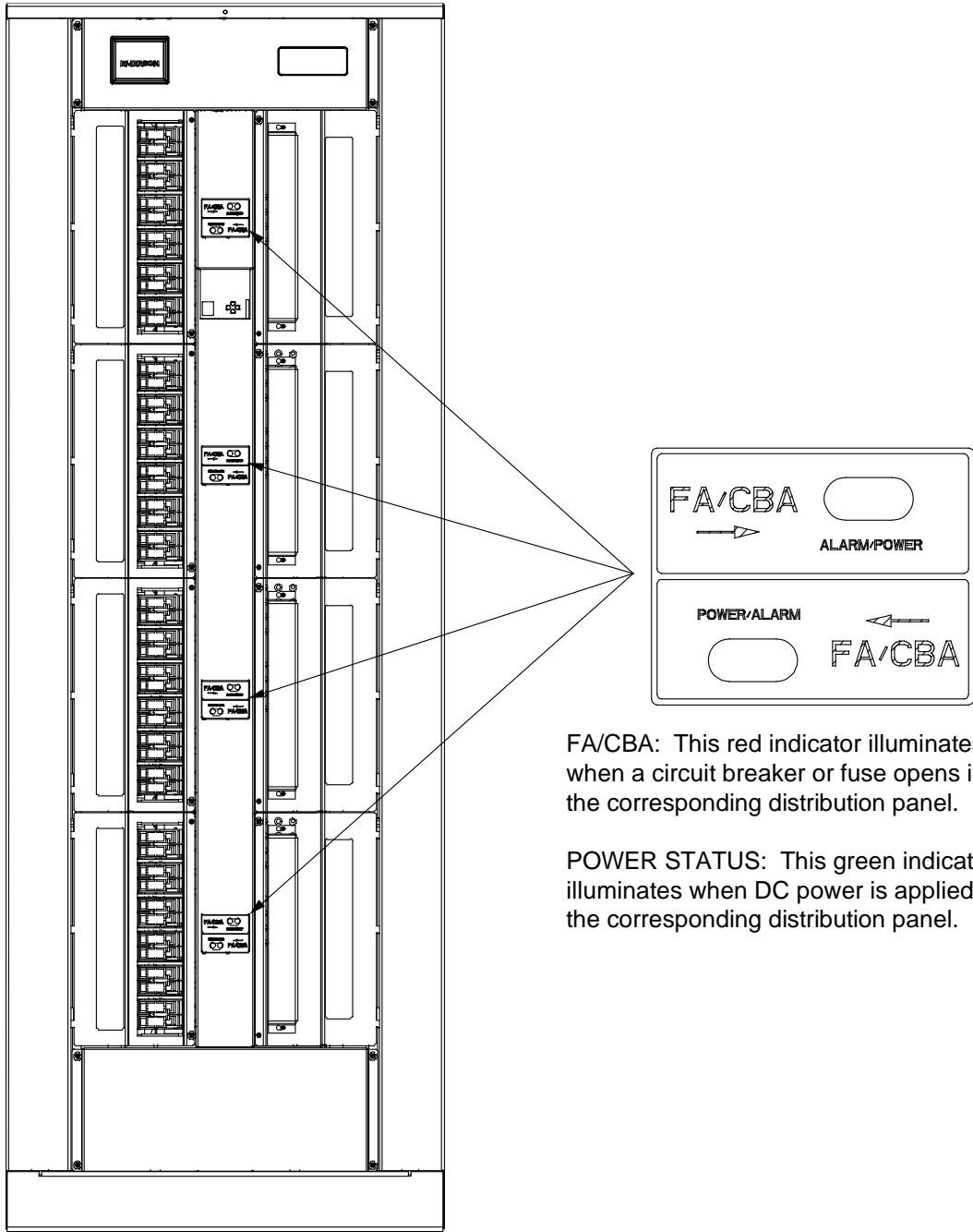

Front View  
8-Panel Bay  
(6-Panel Bay Similar)

FA/CBA: This red indicator illuminates when a circuit breaker or fuse opens in the corresponding distribution panel.

POWER STATUS: This green indicator illuminates when DC power is applied to the corresponding distribution panel.

**Figure 9.2 Default Bay Advanced Panel Distribution Device Numbering Scheme**

Distribution Device #28	Distribution Device #28
<b>Panel 5</b>	<b>Panel 6</b>
Distribution Device #1	Distribution Device #1
Distribution Device #28	Distribution Device #28
<b>Panel 3</b>	<b>Panel 4</b>
Distribution Device #1	Distribution Device #1
Distribution Device #28	Distribution Device #28
<b>Panel 1</b>	<b>Panel 2</b>
Distribution Device #1	Distribution Device #1

6-Panel Bay

Distribution Device #16	Distribution Device #16
<b>Panel 7</b>	<b>Panel 8</b>
Distribution Device #1	Distribution Device #1
Distribution Device #16	Distribution Device #16
<b>Panel 5</b>	<b>Panel 6</b>
Distribution Device #1	Distribution Device #1
Distribution Device #16	Distribution Device #16
<b>Panel 3</b>	<b>Panel 4</b>
Distribution Device #1	Distribution Device #1
Distribution Device #16	Distribution Device #16
<b>Panel 1</b>	<b>Panel 2</b>
Distribution Device #1	Distribution Device #1

8-Panel Bay

### SM-DUE Circuit Card Indicators

An SM-DUE is located in each bay. Refer to Figure 5.1 for location. The SM-DUE is used to monitor individual distribution panels in the bay.

There are two (2) status and alarm indicators located on the SM-DUE. The functions of these indicators are as shown in Table 9.1. Refer to Figure 9.3 for location.

**Table 9.1 SM-DUE Indicators**

Indicator	Normal State	Fault State	Description
Operation (Green)	On	--	Unit is operating normally.
	--	Off	Unit is non-operational.
	Flashing	--	Unit is communicating with the monitor unit.
Alarm (Red)	Off	--	Normal State
	--	On	Unit has failed.

**Figure 9.3 SM-DUE Indicator Locations**

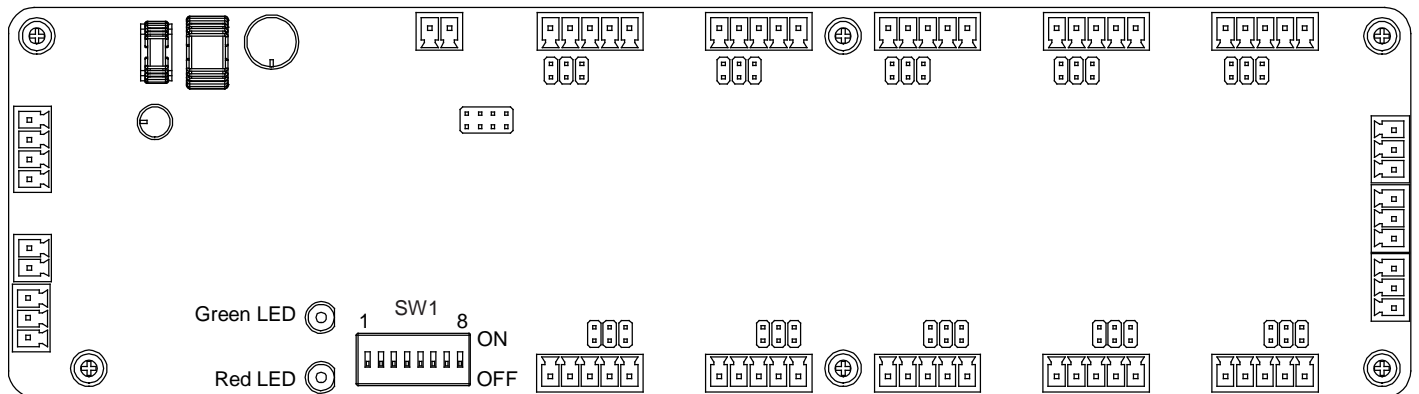

### SM-DUH2 Circuit Card Indicators

The SM-DUH2 is used in a List 15A and List 25A distribution panel to monitor individual distribution devices in the distribution panel. Refer to Figure 5.1 for location.

There are two (2) status and alarm indicators located on the SM-DUH2. The functions of these indicators are as shown in Table 9.2. Refer to Figure 9.4 for location.

**Table 9.2 SM-DUH2 Indicators**

Indicator	Normal State	Fault State	Fault Cause
Operation (Green)	On	--	Unit is operating normally.
	--	Off	Unit is non-operational.
	Flashing	--	A 1 Hz flashing indicates the unit is communicating with the monitor unit.
	--	Flashing	A 1/3 Hz flashing indicates a communication failure.
Alarm (Red)	Off	--	Normal State
	--	On	Alarm (hardware fault or bus voltage sampling fault).

**Figure 9.4 SM-DUH2 Circuit Card Indicator Locations**

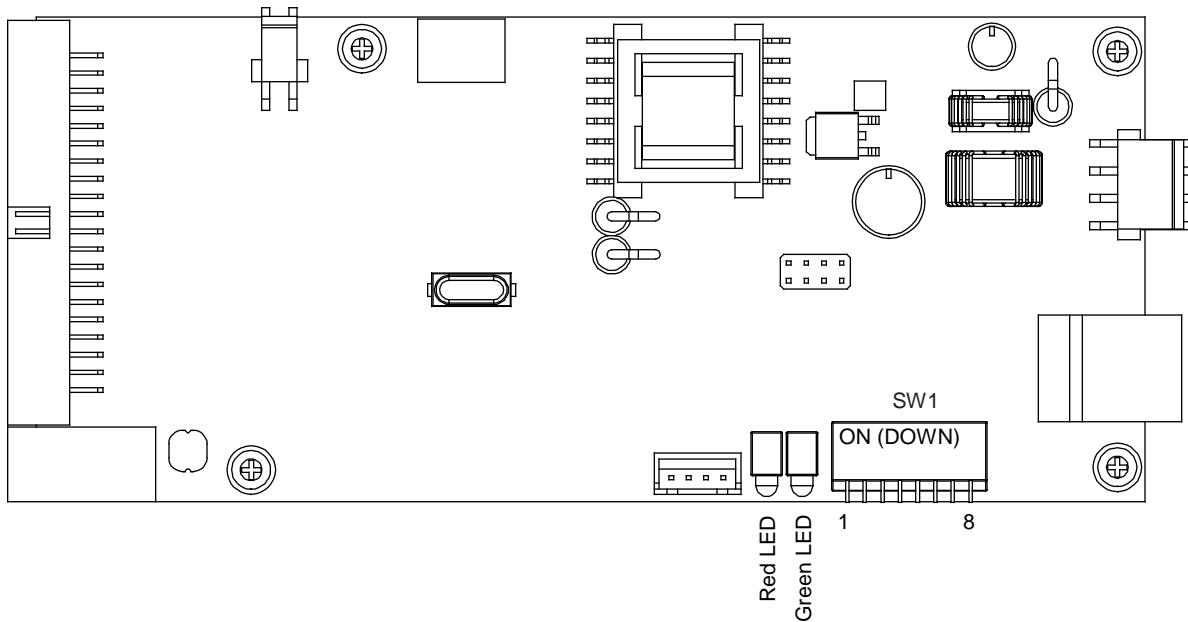

# 10 Maintenance

## 10.1 Important Safety Instructions



**DANGER!** Adhere to the “Important Safety Instructions” presented at the front of this document.

## 10.2 Routine Maintenance

The BDF/CBB requires minimal routine maintenance when installed correctly. The procedures listed in Table 10.1 may be performed at the recommended interval to provide a service record for the system. The table references specific sections in this instruction manual which help in performing these procedures.

**Table 10.1 Procedures that May be Performed to Provide a Service Record for the System**

Procedure	Interval	Referenced In
Check ventilation openings for obstructions such as dust, papers, manuals, etc.	1 year	--
Inspect and tighten all installer's connections.	6 months	“Making Electrical Connections” starting on page 23.
Check Circuit Breaker/Fuse Alarms	3 months	“Checking Circuit Breaker Alarm / Fuse Alarm” on page 59.

## 10.3 System Expansion

### Field Distribution Panel Installation



**DANGER!** Adhere to the “Important Safety Instructions” presented at the front of this document.

Perform the following procedure to add an additional distribution panel to the BDF/CBB.

#### Procedure



**NOTE!** Refer to Figure 10.1, Figure 10.2, and Figure 10.3 as this procedure is performed.

1. Remove blank cover panel(s) where new distribution panel(s) will be installed.
2. Place the new distribution panel into position on the front side of the BDF/CBB.
3. On the front of the BDF/CBB insert and tighten the four screws securing the new distribution panel to the bay.
4. Locate in the bay's wiring harness near the new panel, the unconnected insulated quick connector for the FA/CBA alarm circuits. Connect this to the tab located on the center alarm bus of the distribution panel. Connect from the rear of the bay. Refer to Figure 10.3.
5. If the new distributing panel has a List 43, locate in the bay's wiring harness near the new panel, the unconnected connectors for the shunt leads. Connect these as shown in Figure 10.3. Otherwise terminate to busbar.
6. Locate in the bay's wiring harness near the new panel, the remaining unconnected connectors. Connect these as shown in Figure 10.3.

7. Connect parallel bars as required to power the new panel per the appropriate section of this document.
8. Connect loads to the new panel per the appropriate section of this document.
9. Install distribution devices per the appropriate section of this document.
10. Install the new BDF/CBB front cover panel that was furnished with the new distribution panel.
11. Perform the “Initially Starting, Configuring, and Checking System Operation” procedure on page 56.

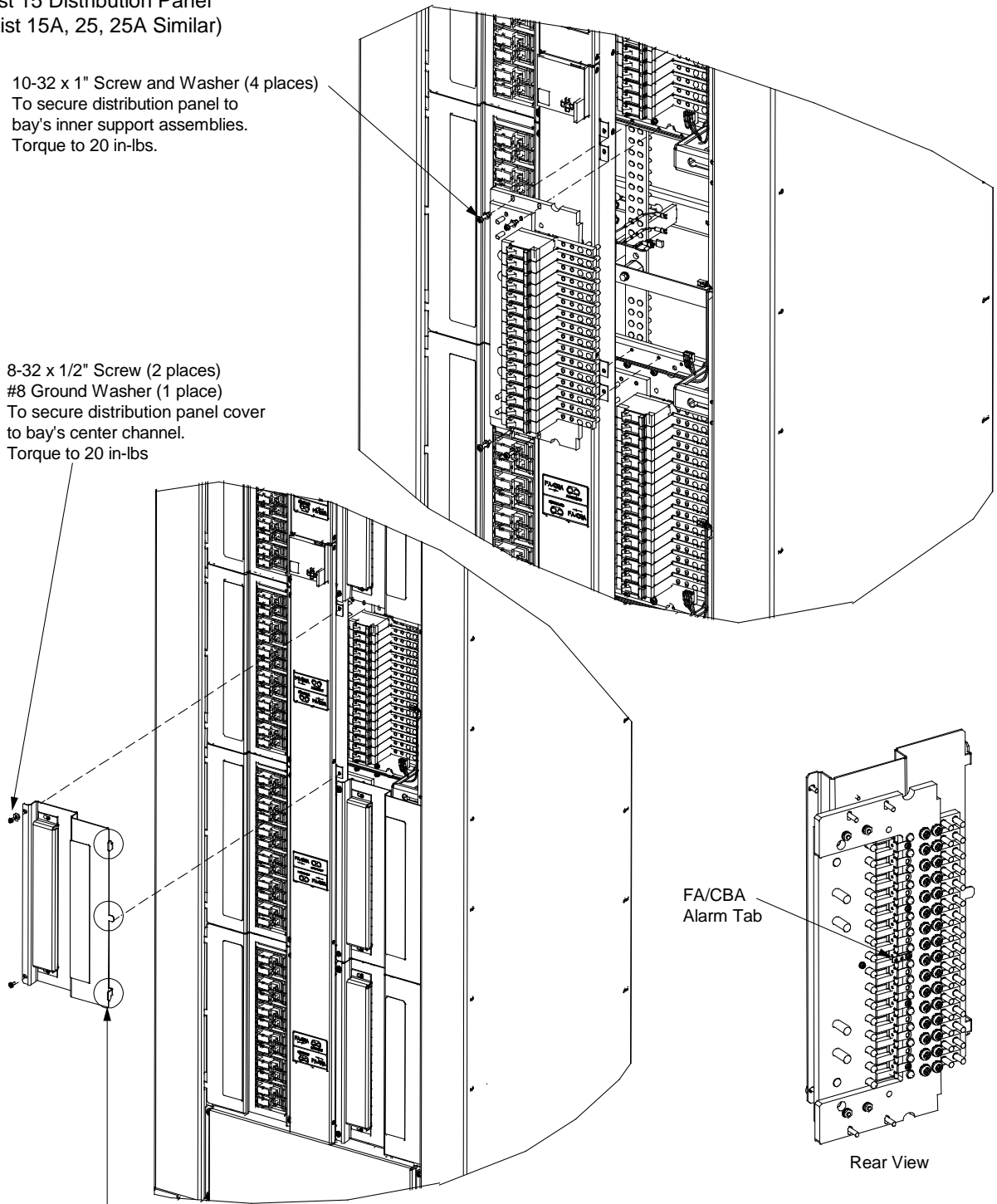

**Figure 10.2** Installing a List 15, List 15A, List 25, or List 25A Distribution Panel

List 15 Distribution Panel  
(List 15A, 25, 25A Similar)

10-32 x 1" Screw and Washer (4 places)  
To secure distribution panel to bay's inner support assemblies.  
Torque to 20 in-lbs.

8-32 x 1/2" Screw (2 places)  
#8 Ground Washer (1 place)  
To secure distribution panel cover to bay's center channel.  
Torque to 20 in-lbs



Tabs  
(Slide distribution panel cover at an angle so tabs fit into slots on bay. Secure other side of distribution panel cover with screws and ground washer as shown.)

Figure 10.3 Connecting the System Wire Harness to the Distribution Panel

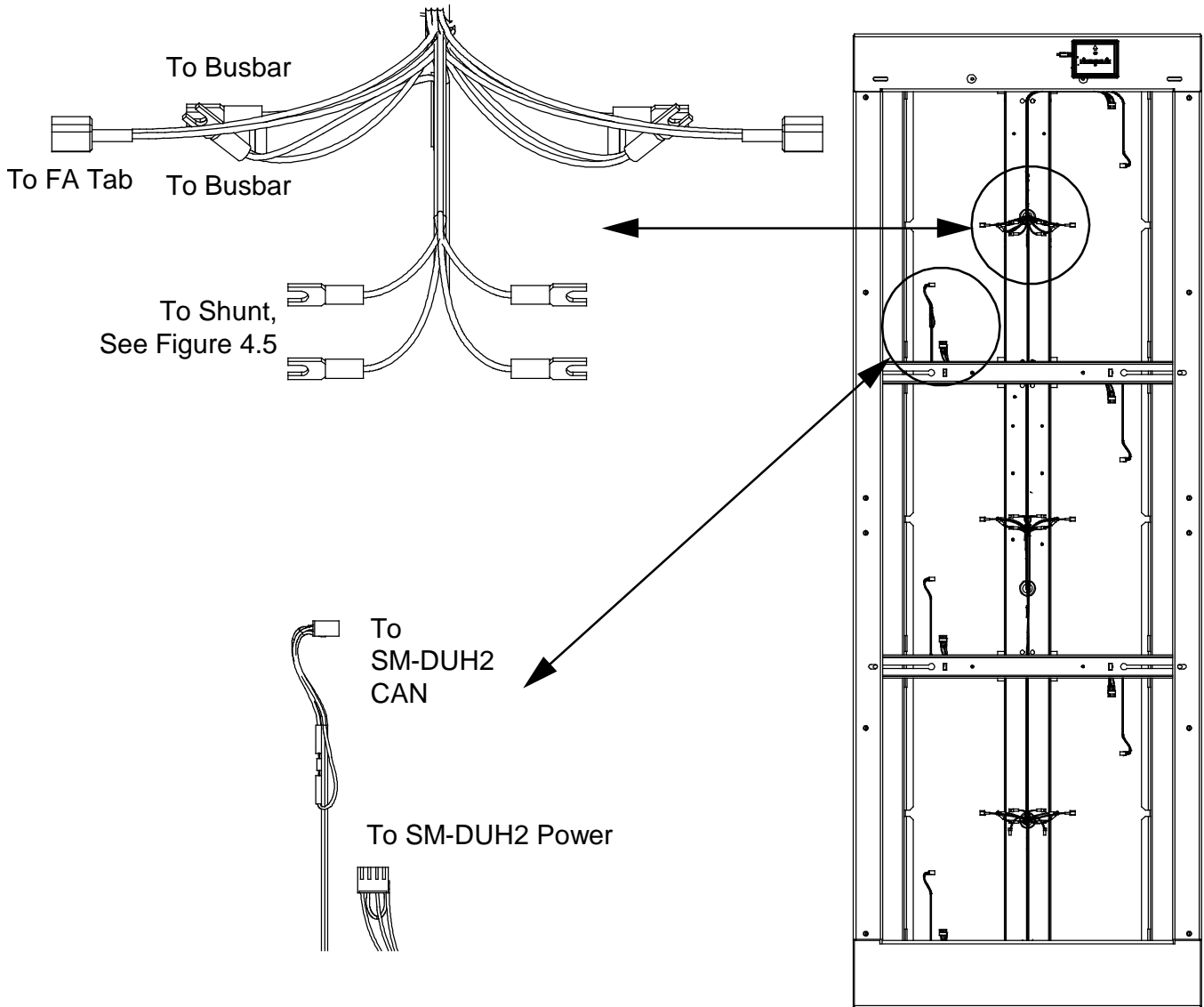

# 11 Troubleshooting and Repair

## 11.1 Important Safety Instructions



**DANGER!** Adhere to the “Important Safety Instructions” presented at the front of this document.

## 11.2 Contact Information

Refer to Section 4.15.4 (provided with your customer documentation) for support contact information.

## 11.3 Monitor Unit

### **General**

For troubleshooting and repair instructions on the monitor unit, refer to the Monitor Unit User Instructions (UM1M832DNA).

### **Monitor Unit Configuration**

If any monitor unit configuration settings were changed, refer to the Monitor Unit Instructions (UM1M832DNA) and save a copy of the configuration file. This file can be used to restore the monitor unit settings, if required, at a later date.

## 11.4 System Troubleshooting Information

This system is designed for ease in troubleshooting and repair. The various indicators as described in “Local Controls and Indicators” on page 62 and in the monitor unit instruction manual are designed to isolate failure to a specific element. Once the faulty element has been identified, refer to “Replacement Information” on page 72 and “Replacement Procedures” on page 72.

### **Troubleshooting Alarm Conditions on the Monitor Unit**

The monitor unit displays alarm conditions as listed in the “Resolving Alarms” section of the Monitor Unit Instructions (UM1M832DNA). Programmable external alarm relays are also available. Refer to the configuration drawing (C-drawing) supplied with your system documentation for your alarm relay configurations.

The monitor unit’s **Active Alarm** and **Alarm History** submenus allow the User to view alarm details. Refer to the Monitor Unit Instructions (UM1M832DNA) to access these menus.

## 11.5 Replacement Information

### **User Replaceable Components**

When a trouble symptom is localized to a faulty monitor unit or system circuit card; that particular device or circuit card should be replaced in its entirety. No attempt should be made to troubleshoot or repair individual components on any monitor unit or circuit card.

Refer to SAG582140600 (System Application Guide) for replacement part numbers.

## 11.6 Replacement Procedures



**DANGER!** Adhere to the “Important Safety Instructions” presented at the front of this document.

### 11.6.1 Replacing the Monitor Unit

Refer to the Monitor Unit Instructions (UM1M832DNA) for a replacement procedure.

## 11.6.2 Replacing a Distribution Device

### **General**

Replace distribution devices with the same type and rating. Refer to SAG582140600 (System Application Guide) for part numbers.

### **Safety Fuse Covers**

Safety fuse covers are provided for all alarm-type fuses installed in the system. These covers snap onto the fuses and provide protection from exposed electrical terminations when a fuse opens. Ensure that the safety fuse cover is installed after replacing a fuse. Refer to Figure 11.1 for installation details.

**Figure 11.1 Installation of Safety Fuse Covers**

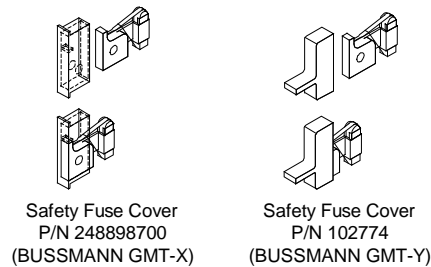

### **Replacing a Fuse on the Auxiliary Fuse Board**

An auxiliary fuse board is located behind an access panel at the top right side of the bay. See Figure 11.2. This circuit card provides four (4) fused auxiliary -48V power outputs (1-1/3A) and dual (A/B) system electronics input fuses.

### **Procedure**

1. Remove the access panel by removing the screws that secure it. Before removing, note the location of any grounding washers used with the hardware securing the panel.
2. After fuse replacement is complete, re-install the access panel. Ensure grounding washers are replaced in locations noted above.

**Figure 11.2** Replacing a Fuse on the Auxiliary Fuse Board

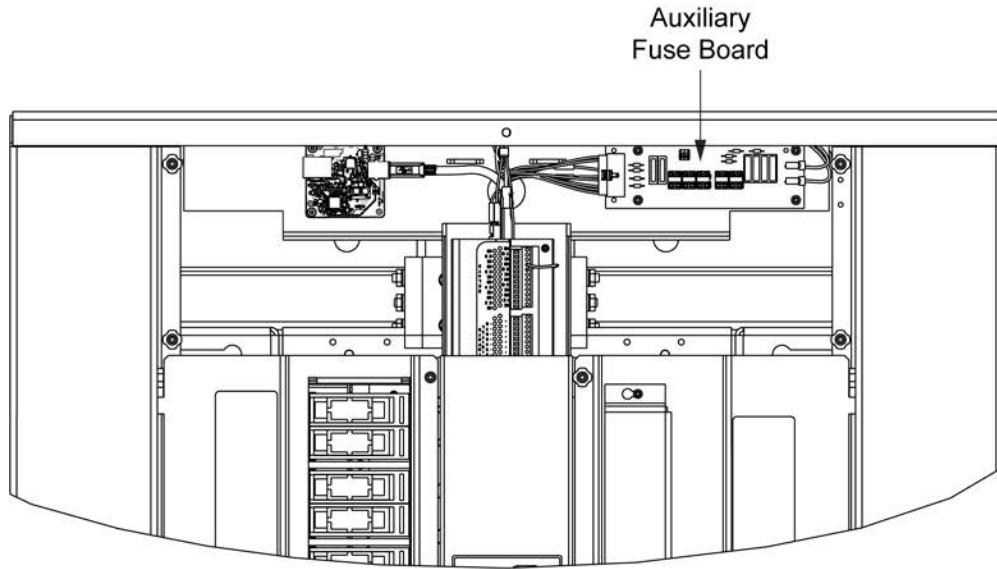

Front  
(top cover panel removed for clarity only)

All fuses 1-1/3A.

Fuse	Function
F1	Aux Load 1A
F2	Aux Load 2A
F3	Aux Load 3B
F4	Aux Load 4B
F5	ABS Power A
F6	ABS Power B

Auxiliary Fuse Board

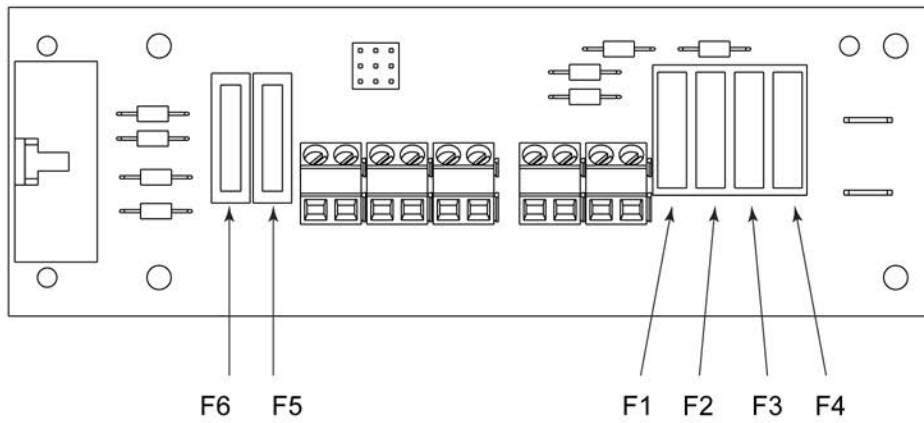

## **Distribution Fuse “Alarm Fuse” Replacement**

If a distribution fuse opens, the associated alarm fuse opens. Replace the distribution fuse before replacing the alarm fuse.

### **Procedure**

1. An alarm fuse is removed by pulling it straight out of the fuseholder. If the alarm fuse is located in a modular fuse carrier, hold the fuse carrier in place with your thumb while pulling on the alarm fuse to prevent the entire carrier from inadvertently being pulled out.

## **Replacing List 10 and List 20 Distribution Panel TLS/TPS Fuses**

Refer to “Installing TLS/TPS Fuses into Respective Fuseholders of a List 10 and List 20 Distribution Panel” on page 52.

Replace the alarm fuse located to the side of the fuse case with a Bussmann GMT 18/100 A alarm fuse. Ensure the alarm safety fuse cover is re-installed.

## **Replacing List 10 and List 20 Distribution Panel TPL-B Fuses**

Refer to “Installing TPL-B Fuses into Respective Fuseholders of a List 10 and List 20 Distribution Panel” on page 53.

Replace the alarm fuse located to the side of the fuse case with a Bussmann GMT 18/100 A alarm fuse. Ensure the alarm safety fuse cover is re-installed.

## **Replacing List 15, List 15A, List 25, and List 25A Distribution Panel TLS/TPS Fuses and/or Fuseholders**

Refer to the “Installing Bullet Nose-Type Fuseholders e/w TLS/TPS Fuses in a List 15, List 15A, List 25, and 25A Distribution Panel” on page 54.

Replace the alarm fuse located on the fuse case with a Bussmann GMT 18/100 A alarm fuse. Ensure the alarm safety fuse cover is re-installed.

## **Replacing List 15, List 15A, List 25, and List 25A Distribution Panel Circuit Breakers**

Refer to the “Installing Bullet Nose Type Circuit Breakers in a List 15, List 15A, List 25, and 25A Distribution Panel” on page 54.

## **Replacing List 10 and List 20 Distribution Panel Fuseholders**

For fuseholder replacement, refer to Figure 11.3.

**Figure 11.3 List 10 and List 20 Distribution Panel Fuseholder Replacement**

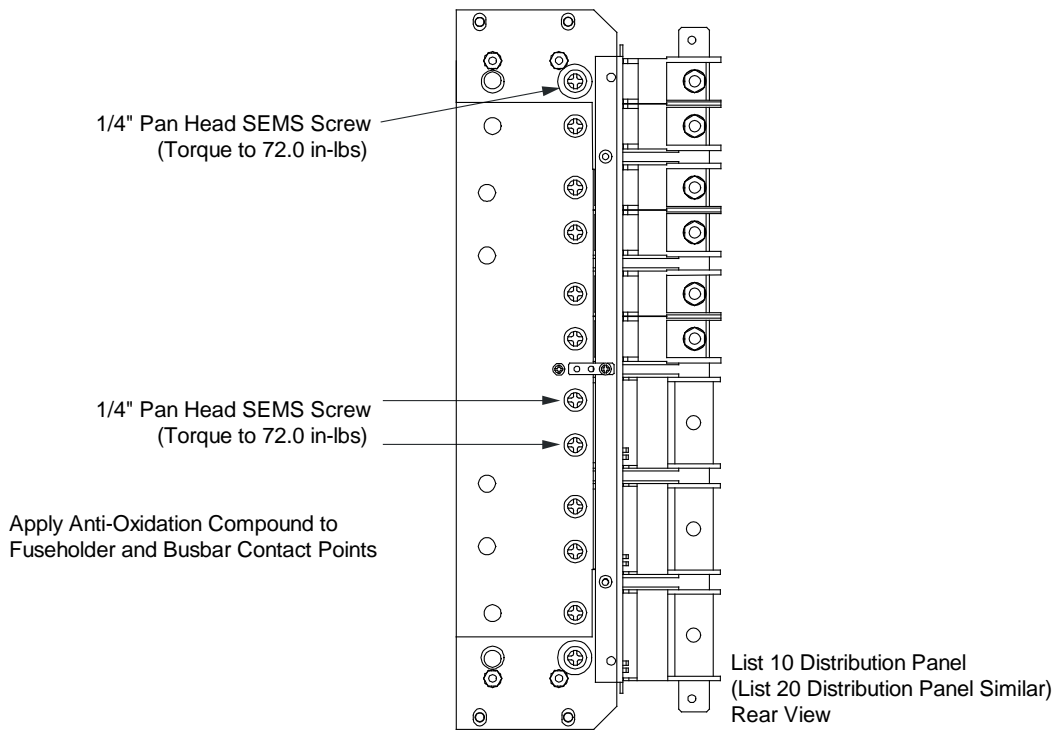
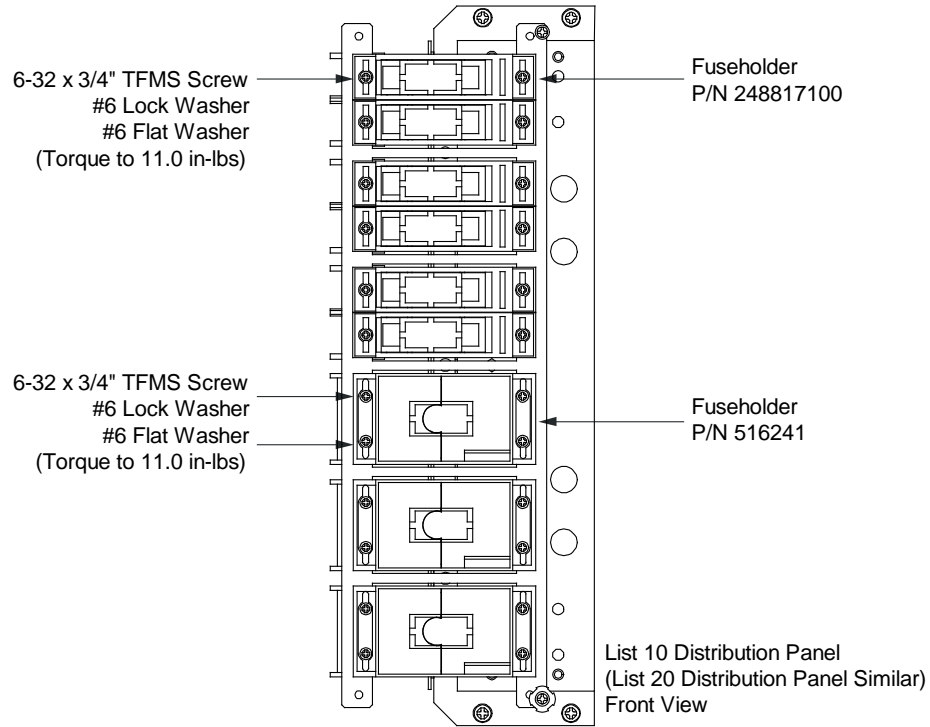

### 11.6.3 Circuit Card Replacement Procedures



**DANGER!** Adhere to the “Important Safety Instructions” presented at the front of this document.



**WARNING!** Circuit cards used in this system contain static-sensitive devices. Read the Static Warning at the front of this document before performing any of the following procedures.

#### **General**

The following circuit card replacement procedures can be performed with the system operating.

#### **Circuit Card Locations**

Refer to Figure 11.4 for circuit card locations.

**Figure 11.4 Circuit Card Locations**

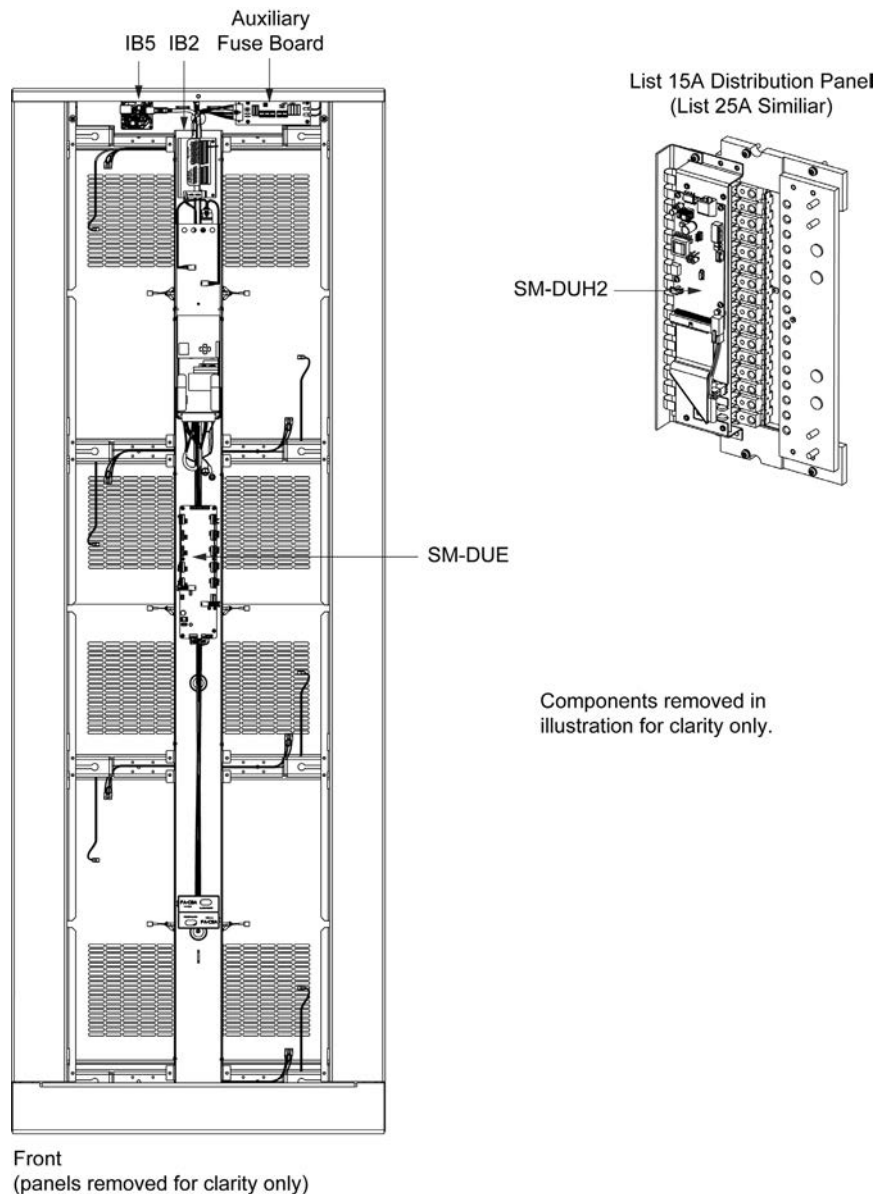

## Replacing the Auxiliary Fuse Board

### Procedure



**NOTE!** Refer to Figure 11.4 for circuit card location. Refer to Figure 11.5 as this procedure is performed.

1. Performing this procedure may activate external alarms. Do one of the following. If possible, disable these alarms. If these alarms cannot be easily disabled, notify the appropriate personnel to disregard any future alarms associated with this system while the procedure is being performed.



**DANGER!** Performing the next steps exposes service personnel to battery potential. Exercise extreme caution not to inadvertently contact or have any tool inadvertently contact any energized electrical termination.



**WARNING!** Damage to the circuit card may result if the next step is not followed.

2. Connect an approved grounding strap to your wrist. Attach the other end to a suitable ground.
3. Remove the top front access panel from the bay. Before removing, note the location and orientation of the grounding washers used with the hardware securing the panel.
4. Label all customer wires connected to the circuit card before removal in the next step. This will provide better identification for reconnection later.



**DANGER!** Some customer wiring may be energized. In the next step, remove wires one at a time, and isolate lead ends with tape or sleeving. Do not allow exposed lead ends to contact any other wires or conductive surfaces.

5. Using a small flat blade screwdriver loosen the small screws securing the customer wires connected to the connector. Remove all wires.
6. Unplug factory-connected wiring from the circuit card at the locations shown in the figure. Some plugs are of the locking type. Hold the lock tab depressed and pull the plug from the mating connector.
7. Loosen and remove the four slotted screws securing the circuit card. Remove the circuit card.
8. Install the new circuit card and secure with four slotted screws.
9. Reconnect the previously-removed factory wiring. For locking type plugs, ensure the plug is fully inserted and locked.
10. Reconnect customer wiring disconnected earlier. Torque specifications are 6.0 inch pounds for customer connections.
11. Replace the top front access panel to the bay. Ensure grounding washers are used with each mounting screw.
12. Remove the grounding wrist strap.
13. Enable the external alarms, or notify appropriate personnel that this procedure is finished.
14. Ensure that there are no local or remote alarms active on the system.

Figure 11.5 Replacing the Auxiliary Fuse Board

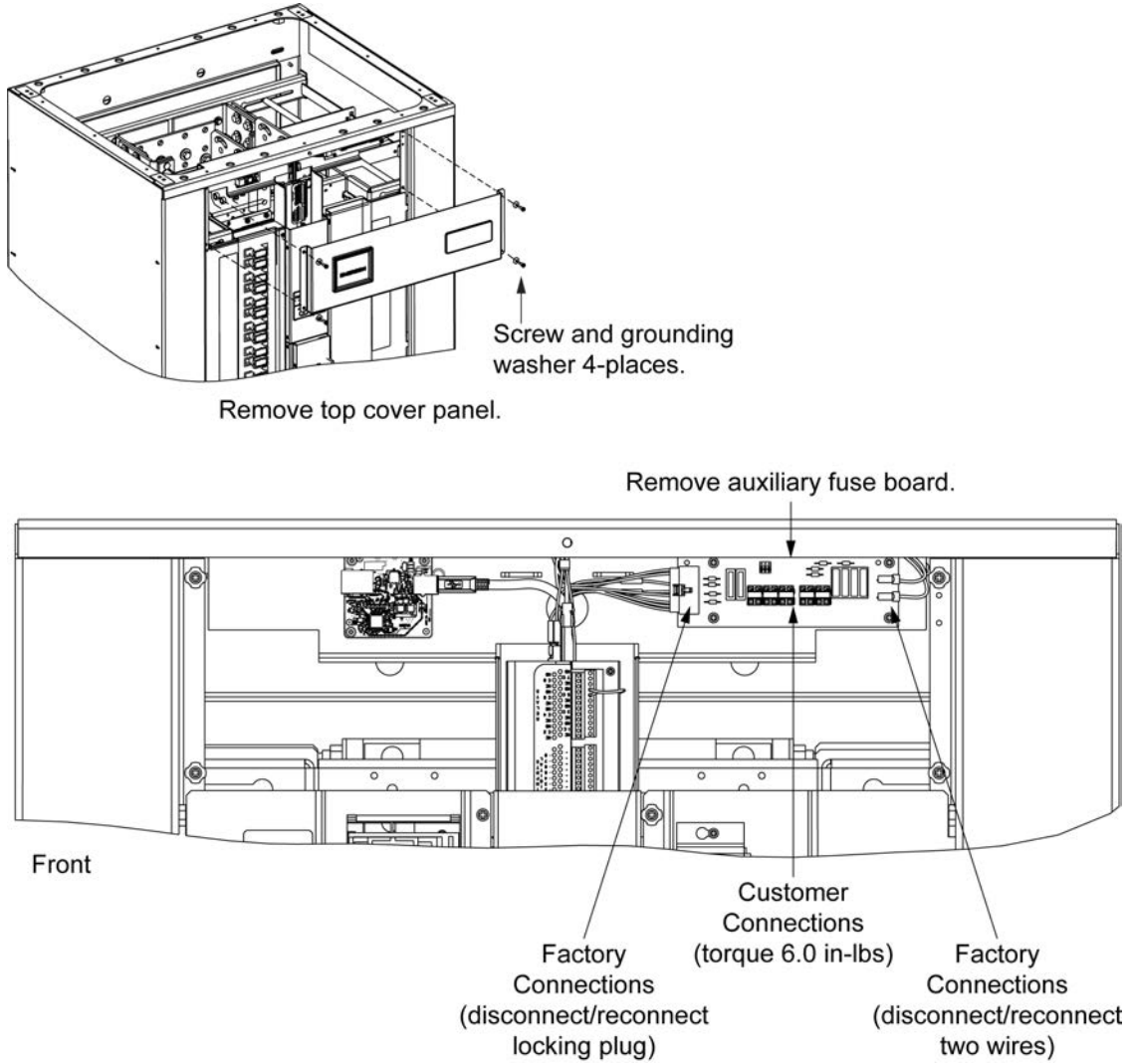

## Replacing the IB2 (Interface Board)

### Procedure



**NOTE!** Refer to Figure 11.4 for circuit card location. Refer to Figure 11.6 as this procedure is performed.

1. Performing this procedure may activate external alarms. Do one of the following. If possible, disable these alarms. If these alarms cannot be easily disabled, notify the appropriate personnel to disregard any future alarms associated with this system while the procedure is being performed.



**DANGER!** Performing the next steps exposes service personnel to battery potential. Exercise extreme caution not to inadvertently contact or have any tool inadvertently contact any energized electrical termination.



**WARNING!** Damage to the circuit card may result if the next step is not followed.

2. Connect an approved grounding strap to your wrist. Attach the other end to a suitable ground.
3. Remove the top front access panel from the bay. Before removing, note the location and orientation of the grounding washers used with the hardware securing the panel.
4. Carefully label the wires connected to the customer connection terminal blocks on the circuit card. These wires must be connected to the same terminals on the replacement circuit card. Refer to Figure 11.6.
5. Carefully label the connectors plugged into the circuit card. These connectors must be plugged into the same connectors on the replacement circuit card. Refer to Figure 11.6.



**DANGER!** In the next step, external alarm wiring may be energized from an external source. DO NOT allow bare wire ends to contact any grounded or energized object.

6. Remove the external wiring from the customer connection terminal blocks. DO NOT allow the bare wire end to contact any grounded or energized object. Isolate the wire end with electrical tape. Repeat for each wire to be removed.
7. Unplug all connectors plugged into the circuit card.
8. Remove the circuit card (and shield) from the bay by removing the screws securing it. See Figure 11.6.
9. In this step, ensure you do not intermix the old and replacement circuit cards. Set the switch on the replacement circuit card to the same setting as the old circuit card. See also “Switch Settings on IB2 Interface Board” on page 16.
10. Secure the replacement circuit card (and shield) to the bay. See Figure 11.6.
11. Plug all connectors removed from the old circuit card into the same position on the replacement circuit card.



**DANGER!** In the next step, external alarm wiring may be energized from an external source. DO NOT allow bare wire ends to contact any grounded or energized object.

12. Reconnect the external wiring to the correct terminals on the customer connection terminal block. First remove the electrical tape that was applied to the bare wire end in a previous step. DO NOT allow the bare wire end to contact any grounded or energized object. After securing the wire, gently tug on the wire to ensure that it cannot be pulled out of the terminal block. Repeat for each wire to be reconnected. Recommended torque for these connections is 2.2 in-lbs.
13. Replace the top front access panel to the bay. Ensure grounding washers are used with each mounting screw.
14. Remove the grounding wrist strap.

15. Enable the external alarms, or notify appropriate personnel that this procedure is finished.
16. Ensure that there are no local or remote alarms active on the system.

**Figure 11.6 Replacing the IB2 (Interface Board)**

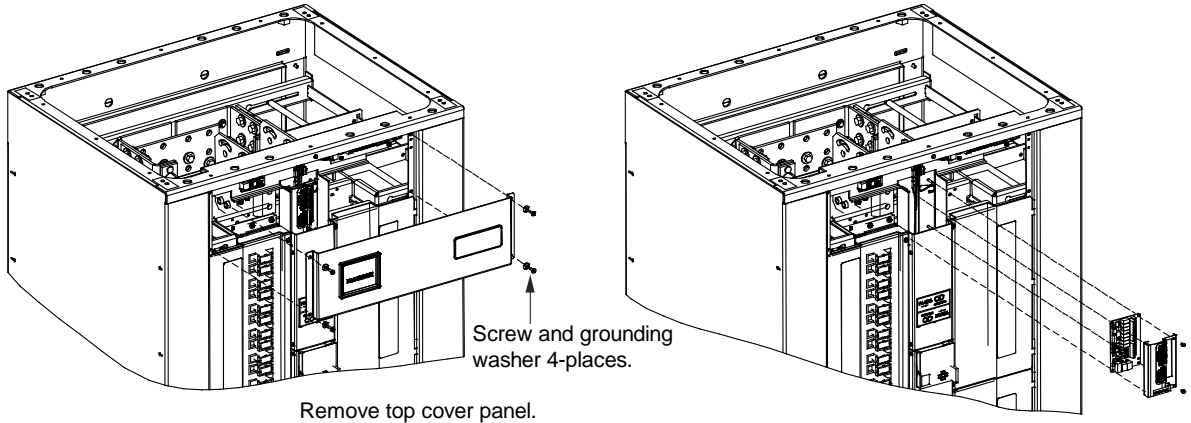

Remove top cover panel.

Remove IB2 assembly.

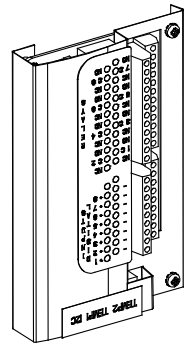
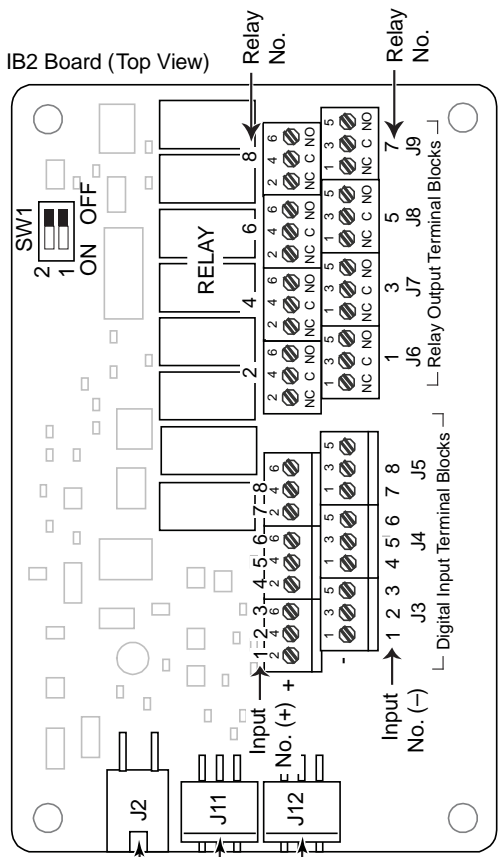

IB2 Assembly

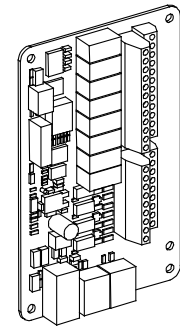

IB2 Board

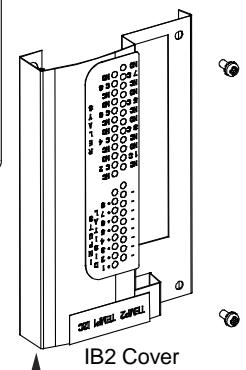

IB2 Cover

This side mounting hardware folds between folds in shield.

J3-J9:  
 Wire Size Capacity: 16 AWG to 26 AWG.  
 Wire Strip Length: 0.20 inch.  
 Recommended Torque: 2.2 in-lbs.

Note: Refer to MAKING SWITCH AND JUMPER SETTINGS section for switch settings.

## Replacing the IB5 Board

### Procedure



**NOTE!** Refer to Figure 11.4 for circuit card location. Refer to Figure 11.7 as this procedure is performed.

1. Performing this procedure may activate external alarms. Do one of the following. If possible, disable these alarms. If these alarms cannot be easily disabled, notify the appropriate personnel to disregard any future alarms associated with this system while the procedure is being performed.



**DANGER!** Performing the next steps exposes service personnel to battery potential. Exercise extreme caution not to inadvertently contact or have any tool inadvertently contact any energized electrical termination.



**WARNING!** Damage to the circuit card may result if the next step is not followed.

2. Connect an approved grounding strap to your wrist. Attach the other end to a suitable ground.
3. Remove the top front access panel from the bay. Before removing, note the location and orientation of the grounding washers used with the hardware securing the panel.
4. Unplug all connectors plugged into the circuit card.
5. Remove the circuit card from the bay by removing the screws securing. See Figure 11.7.
6. Secure the replacement circuit card to the bay. See Figure 11.7.
7. Plug all connectors removed from the old circuit card into the same position on the replacement circuit card.
8. Replace the top front access panel to the bay. Ensure grounding washers are used with each mounting screw.
9. Remove the grounding wrist strap.
10. Reboot the monitor unit.

Local Menu Navigation:

At the Main Screen, press ENT and ESC at the same time to reboot the monitor unit.

Web Menu Navigation:

Advance Settings Menu / SW Maintenance Tab / Reboot button.

11. Enable the external alarms, or notify appropriate personnel that this procedure is finished.
12. Ensure that there are no local or remote alarms active on the system.

Figure 11.7 Replacing the IB5 Board

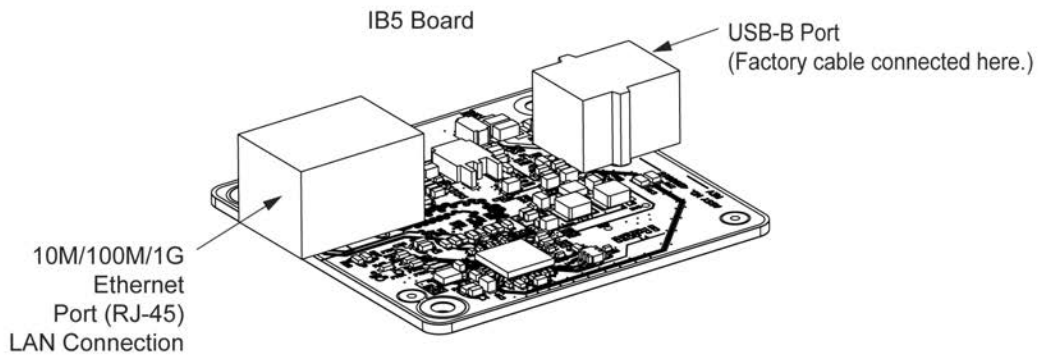
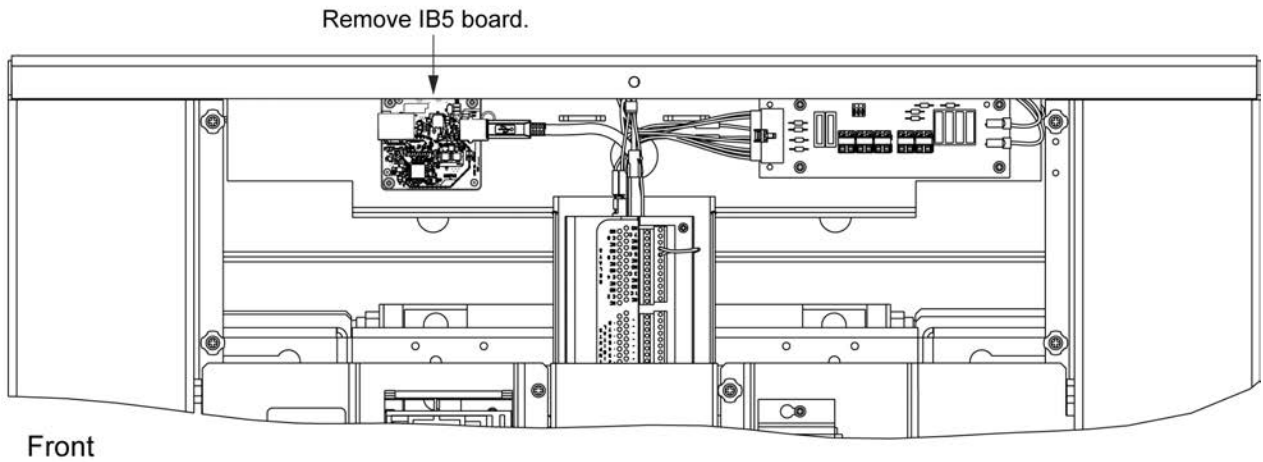
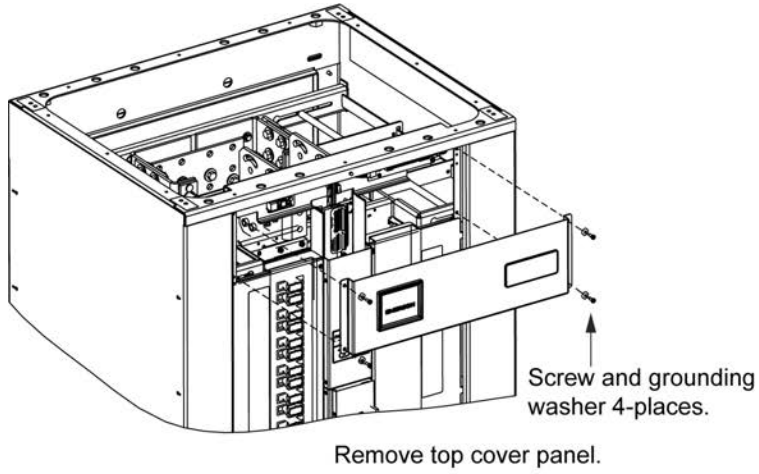

## Replacing the SM-DUE Circuit Card

### Procedure



**NOTE!** Refer to Figure 11.4 for circuit card location. Refer to Figure 11.8 as this procedure is performed.

1. Performing this procedure may activate external alarms. Do one of the following. If possible, disable these alarms. If these alarms cannot be easily disabled, notify the appropriate personnel to disregard any future alarms associated with this system while the procedure is being performed.



**DANGER!** Performing the next steps exposes service personnel to battery potential. Exercise extreme caution not to inadvertently contact or have any tool inadvertently contact any energized electrical termination.



**WARNING!** Damage to the circuit card may result if the next step is not followed.

2. Connect an approved grounding strap to your wrist. Attach the other end to a suitable ground.
3. Remove the front center access panel from the bay. See Figure 11.8. Either slide the panel out of the way to access the SM-DUE circuit card, or completely remove the panel by unplugging the connectors connected to the circuit cards attached to the inside of the panel.
4. Carefully label the connectors plugged into the circuit card. These connectors must be plugged into the same mating connector on the replacement circuit card. Refer to Figure 11.8.
5. Unplug all connectors plugged into the SM-DUE circuit card. REMOVE THE POWER CONNECTOR FIRST.
6. Remove the circuit card from the bay by removing the screws securing. See Figure 11.8.
7. In this step, ensure you do not intermix the old and replacement circuit cards. Set the switches and jumpers on the replacement circuit card to the same setting as the old circuit card. See also “Switch Settings on SM-DUE” on page 17 and “Jumper Settings on SM-DUE” on page 19.
8. Orient the replacement circuit card over its mounting position inside the bay, and secure with the screws removed from the old circuit card.
9. Plug all connectors removed from the old circuit card into the same position on the replacement circuit card. PLUG THE POWER CONNECTOR LAST.
10. Replace the front center access panel to the bay
11. Remove the grounding wrist strap.
12. Temporarily remove then re-insert the monitor unit. Wait for the monitor unit to initialize.
13. Enable the external alarms, or notify appropriate personnel that this procedure is finished.
14. Ensure that there are no local or remote alarms active on the system.

Figure 11.8 Replacing the SM-DUE Circuit Card

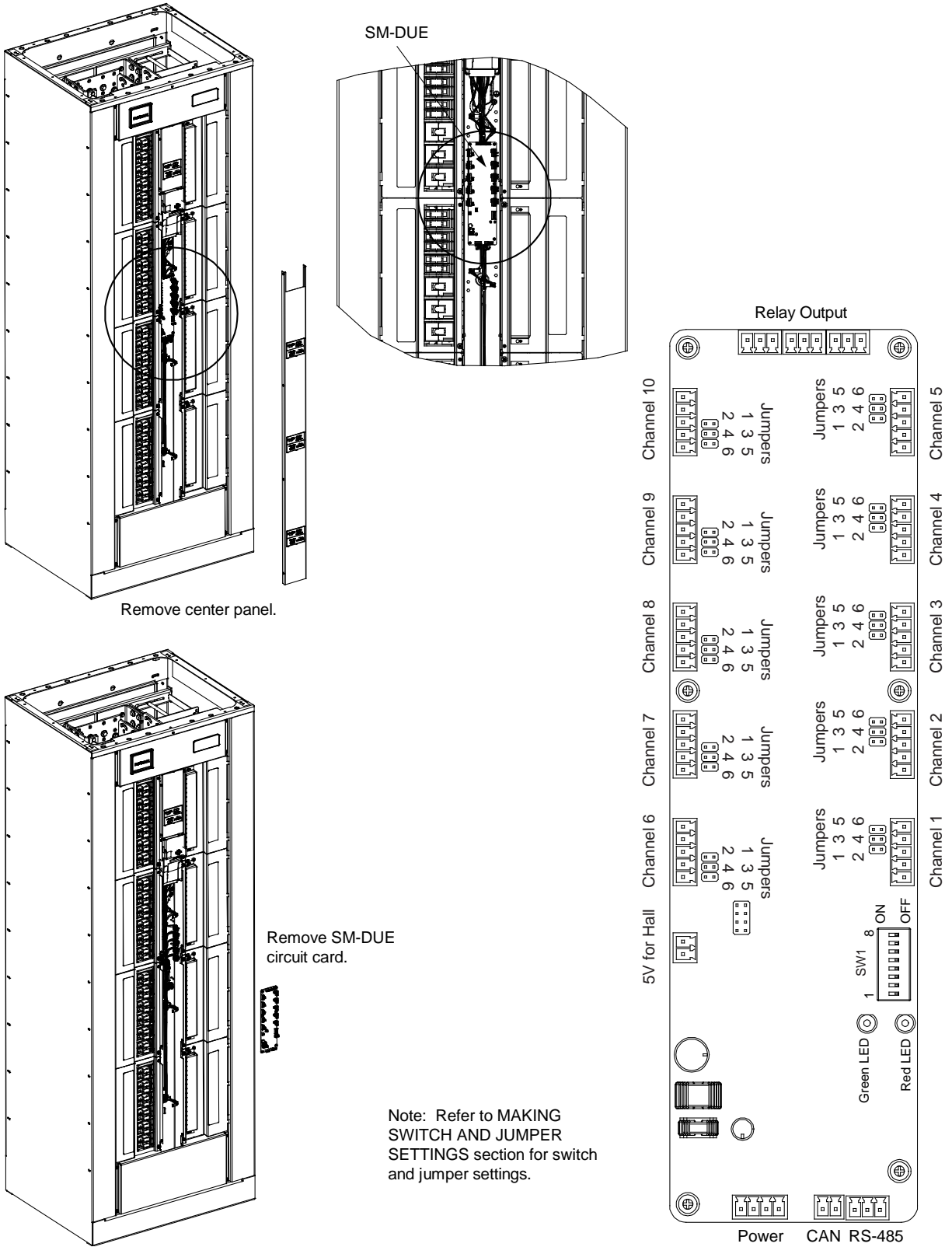

## Replacing the SM-DUH2 Circuit Card

### Procedure



**NOTE!** Refer to Figure 11.4 for circuit card locations. Refer to Figure 11.9 as this procedure is performed.

1. Performing this procedure may activate external alarms. Do one of the following. If possible, disable these alarms. If these alarms cannot be easily disabled, notify the appropriate personnel to disregard any future alarms associated with this system while the procedure is being performed.



**DANGER!** Performing the next steps exposes service personnel to battery potential. Exercise extreme caution not to inadvertently contact or have any tool inadvertently contact any energized electrical termination.



**WARNING!** Damage to the circuit card may result if the next step is not followed.

2. Connect an approved grounding strap to your wrist. Attach the other end to a suitable ground.
3. Remove the distribution panel cover.
4. Carefully label the connectors plugged into the circuit card. These connectors must be plugged into the same mating connector on the replacement circuit card. Refer to Figure 11.9.
5. Unplug all connectors plugged into the SM-DUH2 circuit card. REMOVE THE POWER CONNECTOR FIRST (J1 and J4).
6. Remove the screws securing the circuit card and remove the circuit card from the distribution panel.
7. In this step, ensure you do not intermix the old and replacement circuit cards. Set the switches on the replacement circuit card to the same setting as the old circuit card. See also “Switch Settings on SM-DUH2” on page 21.
8. Orient the replacement circuit card over its mounting position on the distribution panel, and secure with the screws removed from the old circuit card.
9. Plug all connectors removed from the old circuit card into the same position on the replacement circuit card.. PLUG THE POWER CONNECTORS LAST (J1 and J4).
10. Reinstall the distribution panel cover.
11. Remove the grounding wrist strap.
12. Enable the external alarms, or notify appropriate personnel that this procedure is finished.
13. Ensure that there are no local or remote alarms active on the system.

Figure 11.9 Replacing the SM-DUH2 Circuit Card

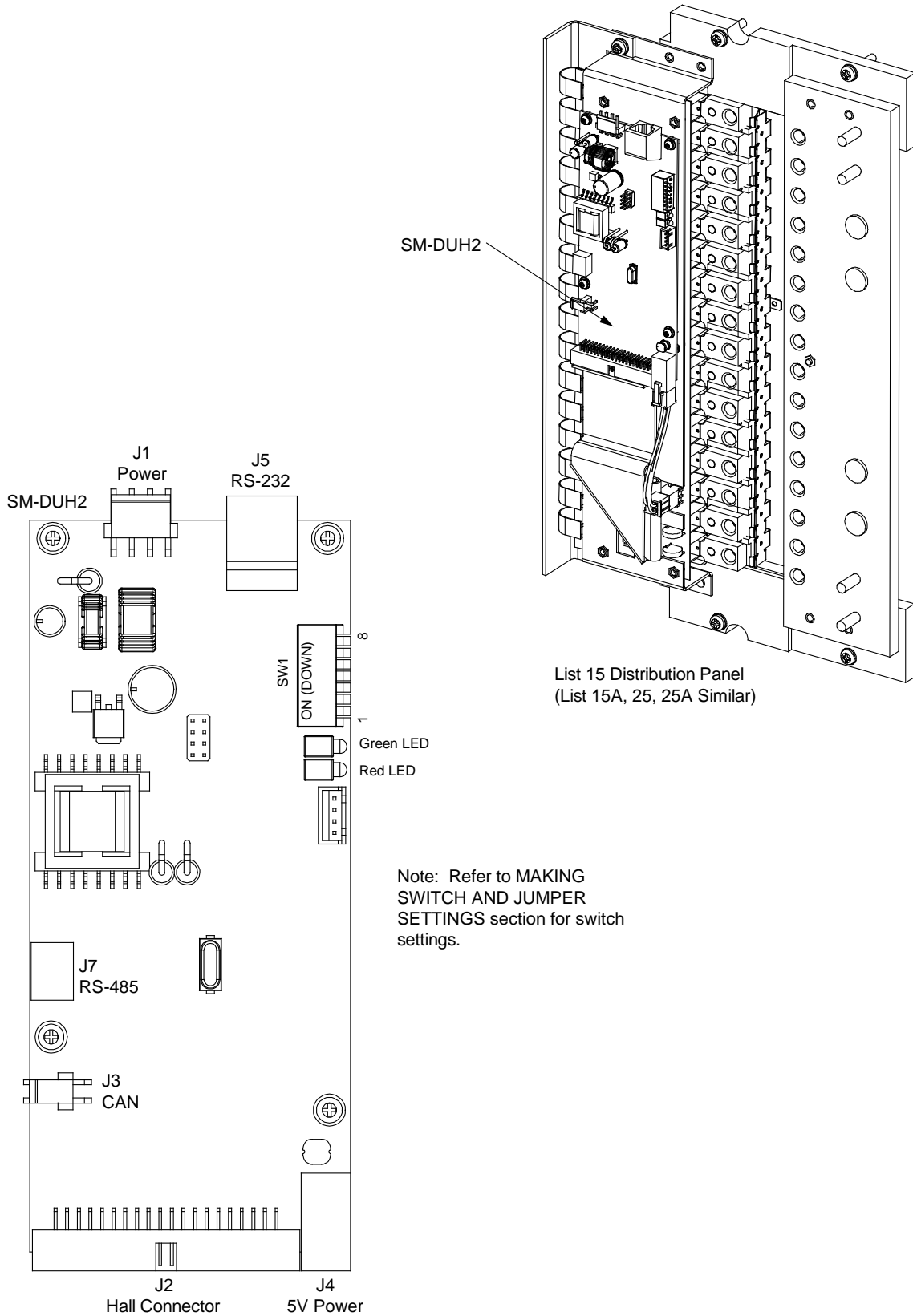

## 11.6.4 Replacing a Distribution Panel



**DANGER!** Adhere to the “Important Safety Instructions” presented at the front of this document.



**DANGER!** All sources of DC power must be completely disconnected from this system before performing this procedure.

Use a voltmeter to verify no DC voltage is present on the system busbars before proceeding.

### **Procedure**



**NOTE!** Refer to Figure 10.1, Figure 10.2, and Figure 10.3 as this procedure is performed.

### **Removing the Distribution Panel**

1. Performing this procedure may activate external alarms. Do one of the following. If possible, disable these alarms. If these alarms cannot be easily disabled, notify the appropriate personnel to disregard any future alarms associated with this system while the procedure is being performed.
2. Remove the distribution panel cover.
3. Disconnect all system load and battery wiring from the distribution panel.
4. Disconnect the alarm wiring from the distribution panel.
5. Disconnect any input wiring to the distribution panel.
6. Remove any paralleling bars from the distribution panel.
7. Remove any input busbars from the distribution panel.
8. Disconnect the bay’s wire harness connectors from the distribution panel.
9. Remove the hardware securing the distribution panel to the bay. Remove the distribution panel from the distribution cabinet

### **Installing the Distribution Panel**

1. Orient the replacement distribution panel into bay. Secure the distribution panel to the bay with the hardware removed from the old panel.
2. Reconnect the bay’s wire harness connectors to the distribution panel.
3. Replace any input busbars to the distribution panel.
4. Replace any paralleling bars to the distribution panel.
5. Reconnect any input wiring to the distribution panel.
6. Reconnect the alarm wiring to the distribution panel.
7. Reconnect the load distribution and battery wiring to the distribution panel.
8. Transfer the circuit breakers or fuses from the old distribution panel to the replacement distribution panel.
9. Replace the distribution panel cover.

### **Restarting the Power System**

1. Reconnect the DC power sources to the system.
2. Start the system. Refer to “Initially Starting, Configuring, and Checking System Operation” on page 56.

3. Enable the external alarms, or notify appropriate personnel that this procedure is finished.
4. Ensure that there are no local or remote alarms active on the system.

## 11.6.5 Replacing an Output Bar with Sensor in a List 15A or List 25A Distribution Panel



**DANGER!** Adhere to the “Important Safety Instructions” presented at the front of this document.

### **Procedure**



**NOTE!** Refer to Figure 11.10 as this procedure is performed.

1. Performing this procedure may activate external alarms. Do one of the following. If possible, disable these alarms. If these alarms cannot be easily disabled, notify the appropriate personnel to disregard any future alarms associated with this system while the procedure is being performed.
2. Remove the front panel cover from the distribution panel.
3. Remove the covers from the rear of the bay to gain access to the rear of the distribution panel.
4. Disconnect the load cable from the output side of the output bar being replaced on the distribution panel.
5. Remove the associated circuit breaker from the distribution panel.
6. Remove the clear protective cover from the front of the distribution panel by removing two (2) screws (one on the top and one on the bottom).
7. Disconnect the flexible ribbon cable attached to the output bar being replaced from the SM-DUH2 circuit board by sliding the retainer back on the connector.
8. Remove the two (2) shoulder bolts securing the output bar being replaced from the rear of the distribution panel.
9. Remove the output bar with sensor.
10. Install the replacement output bar with sensor and secure with the two (2) shoulder bolts previously removed.
11. Connect the flexible ribbon cable attached to the replacement output bar to the SM-DUH2 circuit board.
12. Replace the clear protective cover to the front of the distribution panel and secure with the two (2) screws previously removed (one on the top and one on the bottom).
13. Replace the associated circuit breaker onto the distribution panel.
14. Replace the load cable to the output side of the replacement output bar.
15. Replace the covers onto the rear of the bay
16. Replace the front panel cover over the distribution panel.
17. Enable the external alarms, or notify appropriate personnel that this procedure is finished.
18. Ensure that there are no local or remote alarms active on the system.

**Figure 11.10** Replacing Output Bar / Sensor Assembly in a List 15A or List 25A Distribution Panel

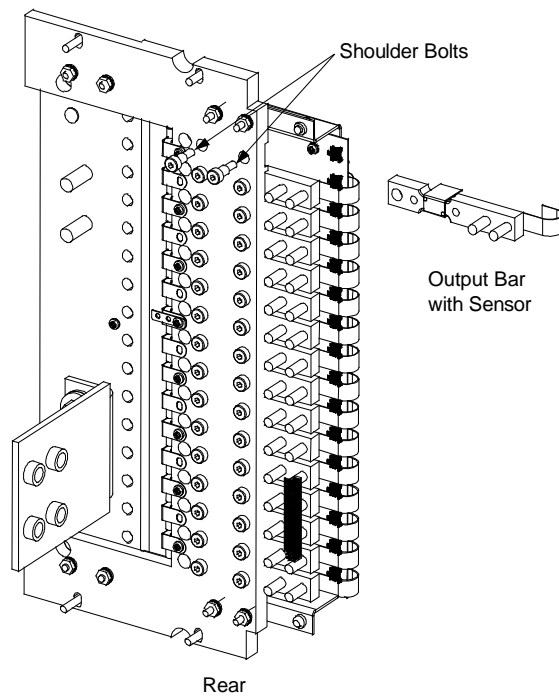
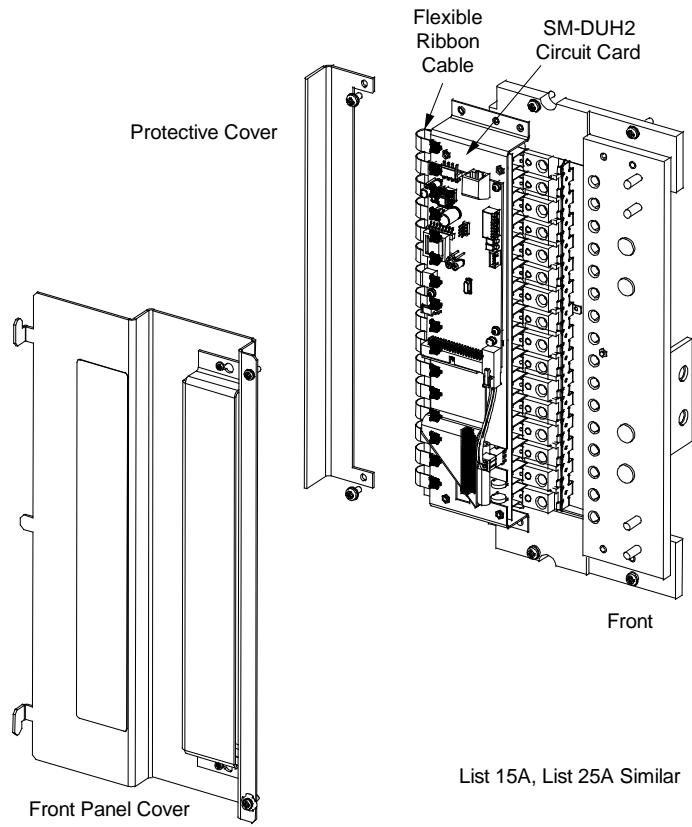

## Connect with Vertiv on Social Media



<https://www.facebook.com/vertiv/>



<https://www.instagram.com/vertiv/>



<https://www.linkedin.com/company/vertiv/>



<https://www.x.com/vertiv/>



---

Vertiv.com | Vertiv Headquarters, 505 N Cleveland Ave, Westerville, OH 43082, USA

© 2026 Vertiv Group Corp. All rights reserved. Vertiv™ and the Vertiv logo are trademarks or registered trademarks of Vertiv Group Corp. All other names and logos referred to are trade names, trademarks or registered trademarks of their respective owners. While every precaution has been taken to ensure accuracy and completeness here, Vertiv Group Corp. assumes no responsibility, and disclaims all liability, for damages resulting from use of this information or for any errors or omissions.