

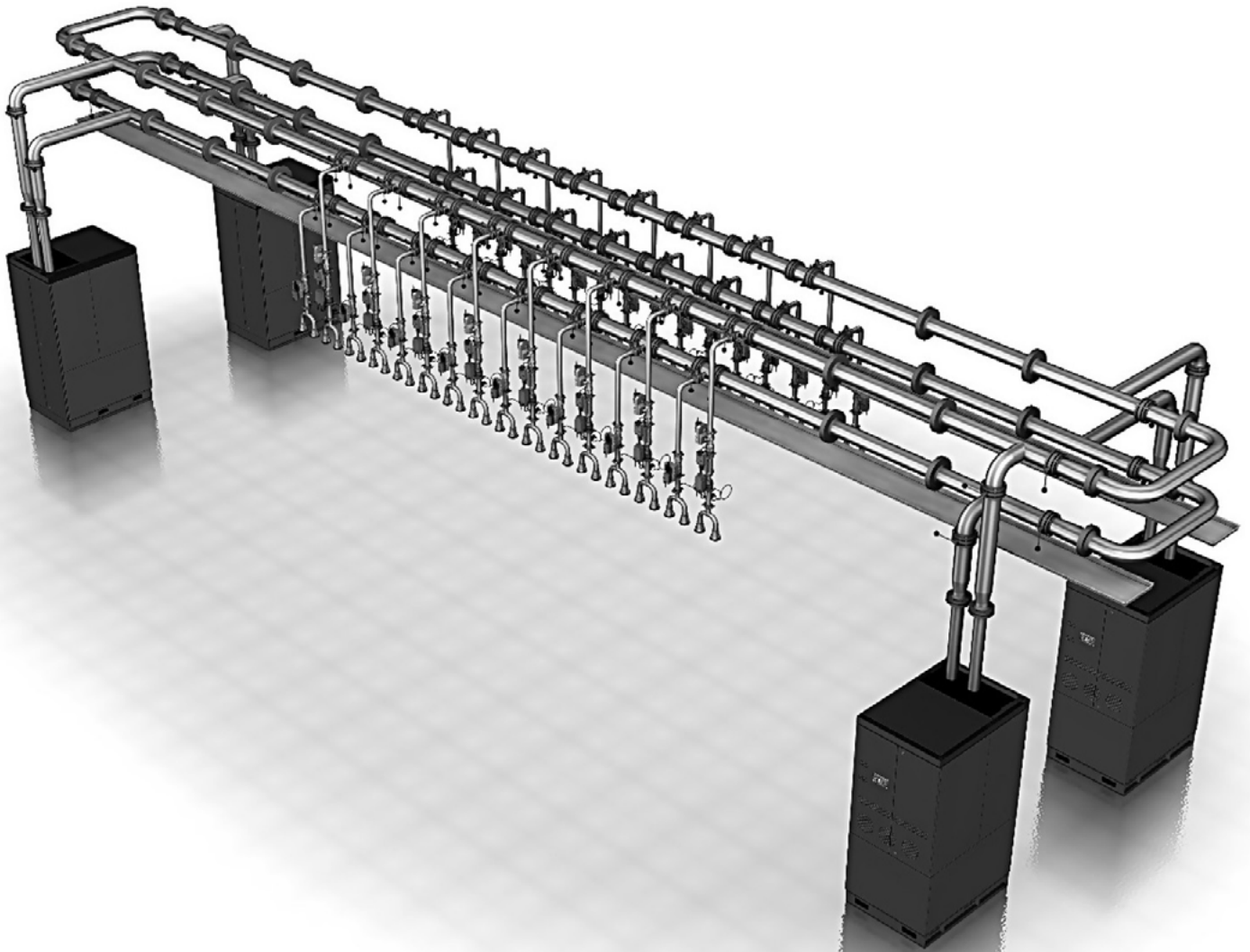

Brochure

Vertiv™ CoolChip Fluid Network

Row-based manifolds



Row-based manifolds

In-row fluid networks form the circulatory backbone of liquid-cooled data centers. The Vertiv™ CoolChip Fluid Network row manifold efficiently distributes coolant from the CDU to multiple racks and simplifies piping across high-density deployments.

Its configurable design speeds up installation, streamlines integration, and supports modular expansion as compute requirements grow. Row-based manifolds are well suited for fast-scaling environments such as AI, HPC, and GPU-dense enterprise deployments.

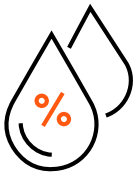
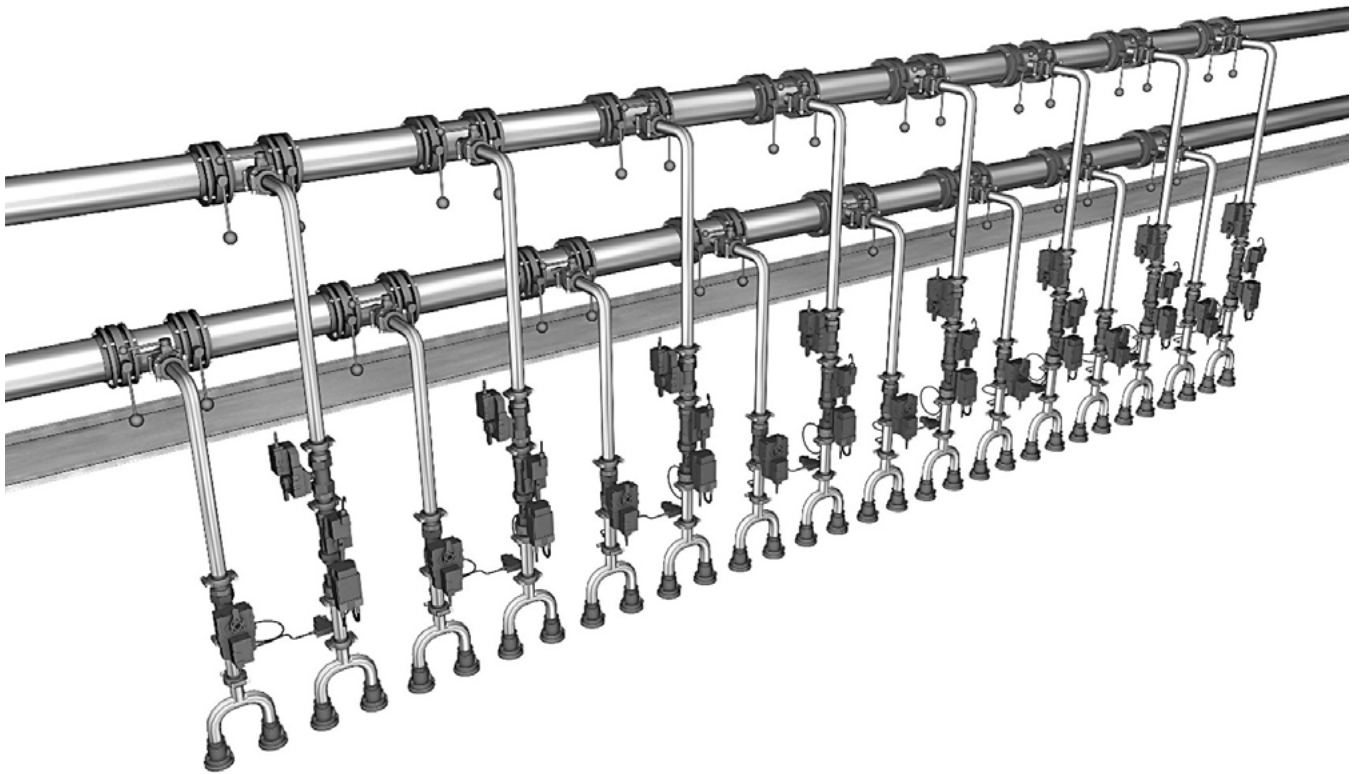

Simple maintenance

Prefabricated assemblies reduce labor hours on-site, while solenoid valve design enables bypass during maintenance for limited impact to operations.

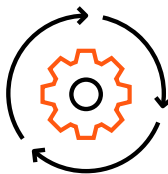

Faster deployment

Rapid installation compared to normal stainless-steel assemblies, arriving pre-fabricated, pre-welded, pre-cleaned, and ready for assembly.



Increased efficiency, reduced OPEX

Lower surface roughness reduces fluid friction loss, improves pump efficiency, and enhances overall system energy performance, contributing to better PUE (Power Usage Effectiveness).



Key components

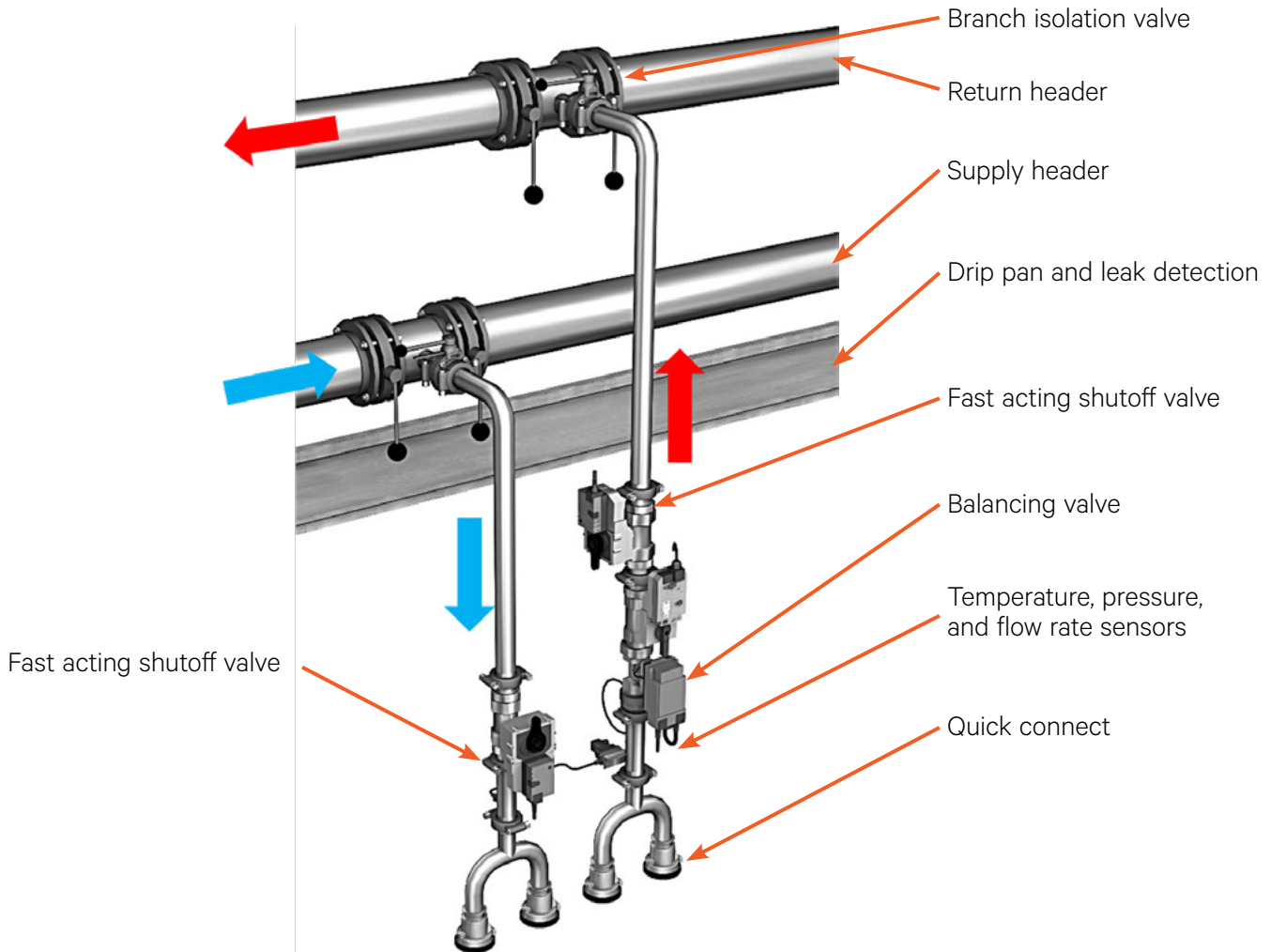

Span Module

Main Manifold Diameter	4", 6", 8"
Branch out to rack manifold diameter	1", 2"
Pipe Material	Hygienic grade SS304, SS304L, SS316, SS316L

Span Module

Isolation Valve

Pressure Independent Valve/Balancing Valve

Fast Acting Shutoff Valve

Temperature, pressure, flow sensor

Drain Valve This is not shown in the picture

Air Vent This is not shown in the picture

Water Leak Detector This is not shown in the picture

*All wetted materials are compliant with OCP requirements and industry standards.



Vertiv.com | Vertiv Headquarters, 505 N Cleveland Ave, Westerville, OH 43082, USA

© 2025 Vertiv Group Corp. All rights reserved. Vertiv™ and the Vertiv logo are trademarks or registered trademarks of Vertiv Group Corp. All other names and logos referred to are trade names, trademarks or registered trademarks of their respective owners. While every precaution has been taken to ensure accuracy and completeness here, Vertiv Group Corp. assumes no responsibility, and disclaims all liability, for damages resulting from use of this information or for any errors or omissions. Specifications, rebates and other promotional offers are subject to change at Vertiv's sole discretion upon notice.

SL-80481 (R03/2026)