



CoolPhase Wall

Installation, Maintenance and User Manual

The information contained in this document is subject to change without notice and may not be suitable for all applications. While every precaution has been taken to ensure the accuracy and completeness of this document, Vertiv assumes no responsibility and disclaims all liability for damages result from use of this information or for any errors or omissions.

Refer to local regulations and building codes relating to the application, installation, and operation of this product. The consulting engineer, installer, and/or end user is responsible for compliance with all applicable laws and regulations relation to the application, installation, and operation of this product.

The products covered by this instruction manual are manufactured and/or sold by Vertiv. This document is the property of Vertiv and contains confidential and proprietary information owned by Vertiv. Any copying, use, or disclosure of it without the written permission of Vertiv is strictly prohibited.

Names of companies and products are trademarks or registered trademarks of the respective companies. Any questions regarding usage of trademark names should be directed to the original manufacturer.

Technical Support Site

If you encounter any installation or operational issues with your product, check the pertinent section of this manual to see if the issue can be resolved by following outlined procedures.

Visit <https://www.vertiv.com/en-us/support/> for additional assistance.

TABLE OF CONTENTS

1 Important Safety Instructions	1
1.1 Physical Security	6
1.2 Pipe-work	6
1.3 Refrigerant Leak Detection System	6
1.4 Qualification of Workers	7
1.4.1 Safety Concepts	7
1.4.2 Correct Working Procedures	7
1.5 Installation, Maintenance and Repair, and Decommissioning	9
1.5.1 Checks to the Area	9
1.5.2 Work Procedure	9
1.5.3 General Work Area	9
1.5.4 Checking for Presence of Refrigerant	9
1.5.5 Presence of Fire Extinguisher	9
1.5.6 No Ignition Sources	10
1.5.7 Ventilated Area	10
1.5.8 Checks to the Refrigerant Equipment	10
1.5.9 Checking Electrical Devices	10
1.5.10 Repair to Sealed Components and Intrinsically Safe Components	10
1.5.11 Cabling	11
1.5.12 Detection of Flammable Refrigerants	11
1.5.13 Removal and Evacuation	11
1.5.14 Charging Procedures	12
1.5.15 Decommissioning	12
1.5.16 Labeling	12
1.5.17 Recovery	13
2 Product Overview	15
2.1 Model Nomenclature	15
2.2 Nameplate	18
2.3 Components Location	20
2.4 Accessories	21
2.5 Dimensions and Weights	22
2.6 Storage Environment	22
2.7 Electrical Data	23
2.8 Vertiv™ CoolPhase Wall on Structure Wall Intended Application	23
3 Pre-installation Preparation	25
3.1 Tools Required	25
3.2 Clearance Requirements	25
3.3 Inspecting the Unit	27

3.4 Moving the Packaged Unit	27
3.5 Unpacking the Unit	27
4 Installation	31
4.1 Leveling the Unit	31
4.2 Installing the Indoor Unit	32
4.2.1 Installing the Mounting Bars and the Indoor Units	32
4.2.2 Drilling a Piping Hole in the Wall	38
5 Piping Connection	39
5.1 General Connections	39
5.1.1 Notes and Warnings	39
5.1.2 General Arrangement	40
5.2 Indoor Unit and Condensing Unit Connections	41
5.2.1 Connection Limitations	41
5.2.2 Length of Connections	43
5.2.3 Liquid Pipe and Suction Pipe Connection	44
5.2.4 Piping Insulation	48
5.2.5 Drainpipe Connection	50
5.2.6 Condensate Pump Kit Connection	52
5.2.7 Piping Leak Test	53
5.2.8 Evacuating the Unit	56
6 Electrical Connections	59
6.1 Connecting Power Supply Cable	60
6.2 Connecting Communications Cables	63
6.2.1 General Arrangement	63
6.2.2 Connecting Communications Cable between Indoor Unit and Condensing Unit	65
6.2.3 Connecting the Monitor Device to Unity Card	65
6.2.4 Connecting for Teamwork	65
6.2.5 User Selectable Features	67
6.3 LCD Display Installation and Wiring	68
7 Installation Checklist	71
7.1 Piping Checklist	71
7.2 Electrical Installation Checklist	72
8 Commissioning	73
8.1 Self Check	73
8.2 Charging Refrigerant and Lubricating Oil	73
8.2.1 Amount of Refrigerant and Lubricating Oil	74
8.2.2 Adding Lubricating Oil	76
8.2.3 Charging Refrigerant Statically	77
8.2.4 Charging Refrigerant Dynamically	78
8.3 Start-up Procedure	80

8.3.1 First Start-up (or After Long Standstill)	80
9 LCD Display	81
9.1 LCD Display Overview	81
9.2 LCD Display and Control Buttons	81
9.2.1 On Screen / Home Page	82
9.2.2 Normal Screen / Control Mode	82
9.3 Unit Working Icons	83
9.4 User Menu Structure and Parameters	84
9.4.1 Alarm Menu	84
9.4.2 Alarm Status	85
9.4.3 Alarm Log	85
9.4.4 Alarm	86
9.4.5 Power Menu	86
9.4.6 Temperature Set	87
9.4.7 Evaporator Fan	87
9.4.8 Humidity	88
9.4.9 System Status	88
9.4.10 Run Time	89
9.4.11 Run State	89
9.4.12 Environment	90
9.4.13 Switch In/Out	90
9.4.14 System Menu	91
9.4.15 Help Menu	92
9.5 Menu Structure and Parameters (For Service Personnel)	93
9.5.1 Service Data	93
9.5.2 Manual Mode	94
9.5.3 Logs	94
9.5.4 Temperature	94
9.5.5 Humidity	94
9.5.6 Condenser Fan	95
9.5.7 Evaporator Fan	95
9.5.8 Compressor	96
9.5.9 EEV	96
9.5.10 Teamwork Set	96
9.5.11 Model	99
9.5.12 Select Option	99
9.5.13 Reset Run Time	99
9.5.14 Sensor Alarm	100
9.5.15 Compressor Alarm	100
9.5.16 EEV Alarm	101

9.5.17 Password 101

10 Operation 103

10.1 Automatic Unit Restart 103

10.2 Standard Operation 103

 10.2.1 Auto Mode 103

10.3 Refrigerant Detection System Operation 103

11 Maintenance 105

11.1 Maintenance Schedule 106

11.2 Air Filters 106

11.3 Condensate Drain 110

11.4 Indoor Fan Maintenance 110

11.5 Cleaning the Unit 116

12 Troubleshooting 117

12.1 Self-diagnosis at the Indoor Unit 117

12.2 Before Calling for Service 117

12.3 Self-diagnosis at the LCD Display 118

12.4 Troubleshooting Alarms Displayed at the Indoor Units 119

13 Regulation (EU) 123

Appendices 125

Appendix A: Technical Support and Contacts 125

Appendix B: Submittal Drawings 127

Appendix C: Menu Structure 131

Appendix D: Conformity to EU Directives 136

Appendix E: Conformity to UK Legislations 137

1 Important Safety Instructions

This manual contains important safety instructions that must be followed during the installation and maintenance of the Vertiv™ CoolPhase Wall. Read this manual thoroughly before installing or operating this unit. Only qualified personnel should move, install or service this equipment.

The Vertiv CoolPhase Wall units must be paired only with Vertiv™ CoolPhase Condensing Unit.

This appliance is not intended for use by persons (including children) with reduced physical, sensory or mental capabilities, or lack of experience and knowledge, unless they have been given supervision or instruction concerning use of the appliance by a person responsible for their safety.

Any operation that requires the removal of equipment panels must be performed only by professionally trained and qualified personnel.

To identify the unit model and serial number for assistance or spare parts, locate the nameplate on the unit. The nameplate is located on the right panel of the indoor unit.

The warning label on the exterior of the unit reminds users that:

- The Vertiv CoolPhase Wall restarts automatically in case of a power cut.
- All power sources must be disconnected before gaining access to internal compartment for any operation.

The following safety guidelines are intended to prevent unforeseen risks or damage from unsafe or incorrect operation.

This appliance is designed for installation at a maximum altitude of 6,561.68 ft (2,000 m).

NOTE: If the altitude is higher than 3280.8 ft (1000 m), please contact Vertiv Technical Support.

Only for installation in locations not accessible to the public.

The appliance shall be installed according to national wiring regulations. For USA and Canada follow NFPA 70 National Electrical code and Canadian Electrical Code for the proper electrical installation.



R32 Refrigerant Safety Group A2L



CAUTION: To avoid a hazard due to inadvertent resetting of the thermal cut-off, this appliance must not be supplied through and external switching device, such as a timer, or connected to a circuit that is regularly switched on and off by the utility.



WARNING! The air outlet of the appliance must always be clear of obstruction.



WARNING! Unventilated area where the appliance using flammable refrigerant is installed shall be so constructed that any refrigerant leak will not stagnate to create a fire or explosion hazard.



WARNING! Arc flash and electric shock hazard. Disconnect all electric power supply, verify with a voltmeter that power is Off and wear approved personal protective equipment, (PPE), before working within the electric control enclosure. Failure to comply can cause serious injury or death. Customer must provide earth ground to unit, per national and local codes, as applicable. Before proceeding with installation, read all instructions, verify that all the parts are included and check the nameplate to ensure the voltage matches available utility power. The Vertiv™ Liebert® iCOM™ Edge Controller does not isolate power from the unit, even in the “Unit Off” mode. Some internal components require and receive power even during the “Unit Off” mode of the controller. The only way to ensure that there is NO voltage inside the unit is to install and disconnect all power-supply sources. Refer to unit electrical schematic. Follow all national and local codes.



WARNING! Risk of electric shock. Power down the unit for 10 min before removing any cover.



WARNING! Risk of over pressurization of the refrigeration system. Can cause explosive discharge of high-pressure refrigerant, loss of refrigerant, environmental pollution, equipment damage, injury, or death. This unit contains fluids and gases under high pressure. Use extreme caution when charging the refrigerant system. Do not pressurize the system higher than the maximum allowable pressure marked on the unit's nameplate.



WARNING! Risk of contact with high-speed rotating fan blades. Can cause serious injury or death. Disconnect all electric power-supply sources, verify with a voltmeter that power is off, and verify that all fan blades have stopped rotating before working in the unit cabinet or on the fan assembly. Fan motor controls and compressor controls can maintain an electric charge for 10 minutes after power is disconnected. If control voltage is applied, the fan motor can restart without warning after a power failure.



WARNING! Risk of hair, clothing, and jewelry entanglement with high-speed rotating fan blades. Can cause equipment damage, serious injury or death. Keep hair, jewelry and loose clothing secured and away from rotating fan blades during unit operation.



WARNING! Risk of heavy unit falling over. Improper handling can cause equipment damage, injury, or death. Read all the following instructions and verify that all lifting and moving equipment is rated for the weight of the unit before attempting to move, lift, remove packaging from or prepare the unit for installation. Unit weights are specified in **Table 2.5** on page 22 Indoor Unit Dimensions and Weight.



WARNING! Risk of unsecured unit rolling off pallet. Can cause equipment damage, injury, or death. Ensure the pallet is located on a flat surface before loosening the hardware securing the equipment to its shipping pallet.



WARNING! Risk of contact with extremely hot and/or cold surfaces. Can cause injury. Verify that all components have reached a temperature that is safe for human contact or wear suitable PPE before working within the electric connection enclosures or unit cabinet. Perform maintenance only when the system is de-energized and component temperatures have become safe for human contact.



WARNING! Risk of improper wiring, piping, moving, lifting, and handling. Can cause equipment damage, serious injury or death. Installation and service of this equipment should be done only by qualified personnel who have been specially trained in the installation of air conditioning equipment and who are wearing suitable PPE.



WARNING! Risk of improper wire sizing/rating and loose electrical connections. Can cause overheated wire and electrical connection terminals resulting in smoke, fire, equipment and building damage, injury, or death. Use correctly sized copper wire only and verify that all electrical connections are tight before turning power On. Check all electrical connections periodically and tighten as necessary.



WARNING! Risk of fire. Due to flammable refrigerant used. Follow handling instructions carefully in compliance with national regulations.



WARNING! This unit is not intended to be connected to ducts.



CAUTION: Risk of contact with sharp edges, splinters, and exposed fasteners. Can cause injury. Only professionally trained and qualified personnel wearing suitable PPE should move, lift, remove packaging from or prepare the unit for installation.



CAUTION: Risk of improper moving, lifting, and handling. Can cause equipment damage or injury. Only professionally trained and qualified personnel should work on this equipment. Evaporator fan modules are heavy objects. Use proper lifting techniques and wear suitable PPE to avoid injury and dropping the fan module during removal. Equipment used in handling/lifting, and/or installing the fan assembly must meet Health and Safety national and local requirements. Use handling/lifting equipment rated for the weight of the fan assembly. Use ladders rated for the weight of the fan assembly and technicians if used during installation. Refer to handling/lifting, and/or installation equipment operating manual for manufacturer's safety requirements and operating procedures.



CAUTION: Risk of exposure to harmful noise levels. Can cause hearing injury or loss. Depending on the installation and operating conditions, a sound pressure level greater than 70 dB(A) may arise. Take appropriate technical safety measures. Operating personnel must wear suitable PPE and observe all appropriate hearing protection safety requirements.



CAUTION: Risk of excessive refrigerant line pressure. Can cause tubing and component rupture resulting in equipment damage and personal injury.



CAUTION: High touch current, earth connection essential before connecting supply.

NOTICE

Risk of improper power supply connection can cause equipment damage and loss of warranty coverage. Before connecting any equipment to a main or alternate power source (for example: backup generator systems) for startup, commissioning, testing, or normal operation, ensure that these sources are correctly adjusted to the nameplate voltage and frequency of all equipment to be connected. In general, power source voltages should be stabilized and regulated to within $\pm 10\%$ of the load nameplate nominal voltage. Also, ensure that no three phase sources are single phased at any time.

NOTICE

Risk of oil contamination with water. Can cause equipment damage. Vertiv™ CoolPhase Wall systems require the use of FW68S. Oil absorbs water at a much faster rate when exposed to air than previously used oils. Because water is the enemy of a reliable refrigeration system, extreme care must be used when opening systems during installation or service. If water is absorbed into the oil, it will not be easily removed and will not be removed through the normal evacuation process. If the oil is too wet, it may require an oil change. Oils also have a property that makes them act as a solvent in a refrigeration system. Maintaining system cleanliness is extremely important because the oil can bring foreign matter back to the compressor.

NOTICE

Refrigerant charge must be weighed into air-cooled compressorized systems before they are started. Rotary compressors without proper refrigerant charging can cause the compressors to operate at less than 5°F (-15°C) evaporator temperature and at less than 20 psi (138 kPa). Operation for extended periods at less than 20 psi (138 kPa) can cause premature compressor failure.

NOTICE

Risk of clogged or leaking drain lines and leaking water supply lines. Can cause equipment and building damage.

This unit requires a water drain connection. Drain lines must be inspected at startup and periodically, and maintenance must be performed to ensure that drain water runs freely through the drain system and that lines are clear and free of obstructions and in good condition with no visible sign of damage or leaks.

Improper installation, application and service practices can result in water leakage from the unit. Water leakage can result in catastrophic and expensive building and equipment damage and loss of critical data center equipment.

Do not locate the unit directly above equipment that could sustain water damage.

We recommend installing a monitored fluid detection system to immediately discover and report condensate drain line leaks.

NOTICE

Risk of doorway/hallway interference. Can cause unit and/or structure damage. The unit may be too large to fit through a doorway or hallway while on the skid. Measure the unit and passageway dimensions and refer to the installation plans before moving the unit to verify clearances.

NOTICE

Risk of water backing up in the drain line. Leaking and overflowing water can cause equipment and building damage.

NOTICE

Risk of damage from forklift. Can cause unit damage. Keep tines of the forklift level and at a height suitable to fit below the skid and/or unit to prevent exterior and/or underside damage.

NOTICE

Risk of improper storage can cause unit damage. Keep the unit upright, indoors and protected from dampness, freezing temperatures and contact damage.

NOTICE

Risk of release of hazardous substances into the environment. Can cause environmental pollution and violation of environmental regulations.

The Vertiv™ CoolPhase Wall contains substances and components hazardous for the environment (electronic components, refrigerating gases and oils). At the end of its useful life, the Vertiv CoolPhase Wall must be dismantled by specialized refrigerating technicians. The unit must be delivered to suitable centers specializing in the collection and disposal of equipment containing hazardous substances.

NOTICE

During unit operation, the display might flicker. This does not compromise system performance.

NOTICE

Servicing must be performed only as recommended by this manual.

NOTICE

Handling, installation, cleaning, servicing, and disposal of refrigerant must be done only by qualified personnel.

1.1 Physical Security

This product is designed and intended to be deployed and operated in a physically secure and network firewall-protected location. Vertiv recommends a review of the physical security and operating environment of the unit. Since an attacker or disgruntled user can cause serious disruption, below are some recommended best practices that include, but are not limited to:

- Restrict access to areas, racks, and units with encrypted card RFID/badges, unique multi-factor passcode authentication for access, man traps, and biometric scanners for physical access to the equipment.
- Have trusted and background-checked security guards with 24x7x365 physical presence and written logs to help document and note physical access to a data center, building, rack, and so on.
- Restrict physical access to telecommunications equipment and network cabling. Physical access to the telecommunications lines and network cabling should be restricted to protect against attempts to intercept or sabotage communications. Best practices include use of metal conduits for the network cabling running between equipment cabinets.
- All USB, RJ45, and/or any other physical ports should be restricted on the units.
- Do not connect removable media (such as USB devices, SD cards, and so on) for any operation (such as firmware upgrade, configuration change, or boot application change) unless the origin of media is known and trusted. Before connecting any portable device through a USB port or SD card slot, scan the device for malware and viruses.

1.2 Pipe-work

Pipe-work shall be kept to a minimum.

Pipe-work shall be protected from physical damage and shall not be installed in an unventilated space.

Compliance with national gas regulations shall be observed.

Mechanical connections shall be accessible for maintenance purposes.

Pipe-work including piping material, pipe routing, and installation shall include protection from physical damage in operation and service and be in compliance with national and local codes and standards, such as ASHRAE 15, ASHRAE 15.2, IAPMO Uniform Mechanical Code, ICC International Mechanical Code, or CSA B52. All field joints shall be accessible for inspection before being covered or enclosed.

After completion of field piping for split systems, the field pipework shall be pressure tested with an inert gas and then vacuum tested before refrigerant charging.

Field-made refrigerant joints indoors shall be leak-tested. The test method shall have a sensitivity of five grams per year of refrigerant or better under a pressure of at least 0.25 times the maximum allowable pressure. No leak shall be detected.

1.3 Refrigerant Leak Detection System

According to /CE 60335 requirements, the refrigerant leakage sensor works in places where the system structure is complex and prone to leakage risks. If the refrigerant leaks, the sensor detects that the ambient refrigerant concentration reaches the threshold and will output an alarm. After the refrigerant leak is detected, the internal fan will be forced to open to a certain air volume and wind speed, and the compressor will stop.

The sensor alarm operates using switch signal conversion. When the unit is powered on and there is no refrigerant leak, the contact remains closed. If a leak occurs, the contact opens. The sensor is connected to two relays, which change state in response. This change is detected by the upper controller, triggering an alarm. As a result, the compressor and both internal and external fans adjust their operating states accordingly.

NOTE: The service life of the refrigerant leak detection sensor is 10 years and should be replaced before it expires.

NOTE: If the refrigerant detection system needs to be replaced, it must be replaced by a Vertiv specified refrigerant leak sensor and performed by trained personnel. If assistance is required, please contact Vertiv support.

To verify the mitigation actions, follow the next steps:

1. Set the indoor fans to 50% speed.
2. Turn off the compressor.
3. Turn off the outdoor fan.
4. If the sensor does not detect a concentration above 12% of the LFL, the RD system will automatically reset after 5 minutes.

1.4 Qualification of Workers

Every working procedure that affects safety must be conducted by competent personnel.

Information of procedures additional to usual information for refrigerating appliance installation, repair, maintenance and decommission procedures is required when an appliance with flammable refrigerants is affected.

The training of these procedures is conducted by national training organizations or manufacturers that are accredited to teach the national competency standards that may be set in legislation. The achieved competence should be documented by a certificate.

1.4.1 Safety Concepts

Unventilated - Safety of the appliance does not depend on ventilation of the housing. Switching off the appliance or opening of the housing has no significant effect on safety. Nevertheless, leaking refrigerant may accumulate inside the enclosure and flammable atmosphere is released when the enclosure is opened.

Ventilated enclosure - Safety of the appliance depends on ventilation of the housing. Switching off the appliance or opening of the enclosure has a significant effect on safety. Care should be taken to ensure sufficient ventilation before.

Ventilated room - Safety of the appliance depends on the ventilation of the room. Switching off the appliance or opening of the housing has no significant effect on safety. The ventilation of the room shall not be switched off during repair procedures.

1.4.2 Correct Working Procedures

Commissioning

Ensure the floor area is sufficient for the refrigerant charge or that the ventilation duct is assembled correctly.

Connect the pipes and conduct a leak test before charging with refrigerant.

Check safety equipment before putting it into service.

Maintenance

Ensure there is enough ventilation at the repair location.

Be aware that malfunction of the equipment may be caused by refrigerant loss and a refrigerant leak is possible.

Discharge the capacitors in a way that prevents sparking. After turning off the unit, wait 10 minutes to allow the capacitors to discharge.

Reassemble sealed enclosures accurately. If seals are worn, replace them.

Check safety equipment before putting into service.

Repair

Ensure there is enough ventilation at the repair location.

Be aware that malfunction of the equipment may be caused by refrigerant loss and a refrigerant leak is possible.

Discharge the capacitors in a way that prevents sparking. After turning off the unit, wait 10 minutes to allow the capacitors to discharge.

When brazing is required, the following procedures shall be conducted in the correct order:

- Safely remove the refrigerant in accordance with local and national regulations. If recovery is not required, discharge the refrigerant outdoors. Ensure that the released refrigerant does not pose any danger. If there is any uncertainty, have a person monitor the discharge outlet. Take special care to prevent the refrigerant from flowing back into the building.
- Evacuate the refrigerant circuit.
- Purge the refrigerant circuit with nitrogen for 5 min.
- Evacuate again.
- Remove parts to be replaced by cutting, not by flame.
- Purge the braze point with nitrogen during the brazing procedure.
- Conduct a leak test before charging with refrigerant.

Reassemble sealed enclosures accurately. If seals are worn, replace them.

Check safety equipment before putting into service.

Decommissioning

If the safety is affected when the equipment is putted out of service, the refrigerant charge shall be removed before decommissioning.

Ensure there is enough ventilation at the equipment location.

Be aware that malfunction of the equipment may be caused by refrigerant loss and a refrigerant leak is possible.

Discharge the capacitors in a way that prevents sparking. After turning off the unit, wait 10 minutes to allow the capacitors to discharge.

Remove the refrigerant. If recovery is not required by national regulations, discharge the refrigerant outdoors. Ensure that the released refrigerant does not pose any safety hazards. If there is any doubt, assign a person to monitor the discharge outlet. Take special care to prevent the refrigerant from flowing back into the building.

When flammable refrigerants except A2L refrigerants are used:

- Evacuate the refrigerant circuit.
- Purge the refrigerant circuit with nitrogen for 5 min.

- Evacuate again.
- Fill with nitrogen up to atmospheric pressure.
- Put a label on the equipment indicating that the refrigerant is removed.

Disposal

Ensure there is enough ventilation at the working place.

Remove the refrigerant. If recovery is not required by national regulations, discharge the refrigerant outdoors. Ensure that the released refrigerant does not pose any safety hazards. If there is any doubt, assign a person to monitor the discharge outlet. Take special care to prevent the refrigerant from flowing back into the building.

- Evacuate the refrigerant circuit.
- Purge the refrigerant circuit with oxygen free nitrogen for 5 min.
- Evacuate again.
- Cut out the compressor and drain the oil.

1.5 Installation, Maintenance and Repair, and Decommissioning

1.5.1 Checks to the Area

Prior to beginning work on systems containing flammable refrigerants, safety checks are necessary to ensure that the risk of ignition is minimized. For repair to the refrigerating system, servicing procedures shall be completed before conducting work on the system.

1.5.2 Work Procedure

Work shall be undertaken under a controlled procedure to minimize the risk of flammable gas or vapor being present while the work is being performed.

1.5.3 General Work Area

All maintenance staff and others working in the local area shall be instructed on the nature of work being conducted. Work in confined spaces shall be avoided.

1.5.4 Checking for Presence of Refrigerant

The area shall be checked with an appropriate refrigerant detector before and during work, to ensure the technician is aware of potentially toxic or flammable atmospheres. Ensure that the leak detection equipment being used is suitable for use with all applicable refrigerants, i.e. non-sparking, adequately sealed or intrinsically safe.

1.5.5 Presence of Fire Extinguisher

If any hot work is to be conducted on the refrigerating equipment or any associated parts, appropriate fire extinguishing equipment shall be available to hand. Have a dry powder or CO2 fire extinguisher adjacent to the charging area.

1.5.6 No Ignition Sources

Persons performing work in relation to a refrigerant system which involves exposing any pipe work shall not use any sources of ignition such that they may lead to the risk of fire or explosion. All possible ignition sources, including cigarettes, should be kept sufficiently far away from the site of installation, repairing, removing and disposal, during which refrigerant can possibly be released to the surrounding space. Prior to work taking place, the area around the equipment is to be surveyed to make sure that there are no flammable hazards or ignition risks. “No Smoking” signs shall be displayed.

1.5.7 Ventilated Area

Before opening the system or performing any hot work, ensure the area is either open or adequately ventilated. Ventilation must be maintained throughout the duration of the work. It should safely disperse any released refrigerant and, where possible, expel it safely into the atmosphere outside.

1.5.8 Checks to the Refrigerant Equipment

Where electrical components are being replaced, they shall be fit for the purpose and to the correct specification. Vertiv maintenance and service guidelines are to be followed at all times. Where necessary, consult the technical department for assistance.

The following checks shall be applied to installations using flammable refrigerants:

- The refrigerant charge is in accordance with the room size within which the refrigerant containing parts are installed.
- The ventilation machinery and outlets are operating adequately and are not obstructed.
- If an indirect refrigerating circuit is being used, the secondary circuit shall be checked for the presence of refrigerant.
- Markings on the equipment are always visible and legible. Illegible markings and signs must be corrected.
- Refrigerating pipe or components are installed in a position where they are not exposed to any substances that could corrode refrigerant containing components, unless the components are constructed of materials that are inherently resistant to being corroded or are suitably protected against being corroded.

1.5.9 Checking Electrical Devices

Repair and maintenance to electrical components shall include initial safety checks and component inspection procedures. If a fault exists that could compromise safety, then no electrical supply shall be connected to the circuit until it is satisfactorily inspected. If the fault cannot be corrected immediately but it is necessary to continue operation, an adequate temporary solution shall be used. This shall be reported to the owner of the equipment, keeping all parties are advised.

Initial safety checks shall include:

- Capacitors are discharged: this shall be done in a safe manner to avoid the possibility of sparking.
- No live electrical components and wiring are exposed while charging, recovering, or purging the system.
- That there is continuity of earth bonding.

1.5.10 Repair to Sealed Components and Intrinsically Safe Components

Sealed electrical components shall be replaced.

Intrinsically safe components must be replaced.

1.5.11 Cabling

Check that cabling is not subject to wear, corrosion, excessive pressure, vibration, sharp edges, or any other adverse environmental effects. The check shall also take into account the effects of aging or continual vibration from sources such as compressors or fans.

1.5.12 Detection of Flammable Refrigerants

Under no circumstances shall potentially sources of ignition be used in the searching for or detection of refrigerant leaks. A halide torch (or any other detector using a naked flame) shall not be used.

Electronic leak detectors may be used to detect refrigerant leaks, in the case of flammable refrigerants the sensitivity may not be adequate or may need re-calibration. Detection equipment shall be calibrated in a refrigerant-free area. Ensure that the detector is not a potential source of ignition and is suitable for the refrigerant used. Leak detection equipment shall be set at a percentage of the LFL (Lower Flammable Limit) of the refrigerant and shall be calibrated to the refrigerant employed, and the appropriate percentage of gas (25 % maximum) is confirmed.

Leak detection fluids are also suitable for use with most refrigerants but the use of detergents containing chlorine shall be avoided as the chlorine may react with the refrigerant and corrode the copper pipework. Examples of leak detection fluids are bubble method and fluorescent method agents.

If a leak is suspected, all naked flames shall be removed/extinguished.

If a leakage of refrigerant is found which requires brazing, all the refrigerant shall be recovered from the system, or isolated (by means of shut off valves) in a part of the system remote from the leak. Removal of refrigerant shall be according to Removal and evacuation procedures.

1.5.13 Removal and Evacuation

When breaking into the refrigerant circuit to make repairs – or for any other purpose – conventional procedures shall be used. However, for flammable refrigerants it is important that best practice be followed, since flammability is a consideration. The following procedure shall be adhered to:

- Safely remove refrigerant following local and national regulations.
- Evacuate.
- Purge the circuit with inert gas.
- Evacuate.
- Continuously flush or purge with inert gas when using flame to open circuit.
- Open the circuit

The refrigerant charge shall be recovered into the correct recovery cylinders. For appliances containing flammable refrigerants, the system shall be purged with oxygen-free nitrogen to render the appliance safe for flammable refrigerants. This process might need repeating numerous times. Compressed air or oxygen shall not be used for purging refrigerant systems.

For appliances containing flammable refrigerants, refrigerants purging shall be achieved by breaking the vacuum in the system with oxygen-free nitrogen and continuing to fill until the maximum allowable pressure is achieved, then venting to atmosphere, and finally pulling down to a vacuum. This process shall be repeated until no refrigerant is within the system. When the final oxygen-free nitrogen charge is used, the system shall be vented down to atmospheric pressure to enable work to take place. This operation is vital if brazing operations on the pipework are to take place.

The outlet for the vacuum pump is not close to any potential ignition sources and ventilation shall be available.

1.5.14 Charging Procedures

In addition to conventional charging procedures, the following requirements shall be followed:

- Ensure that contamination of different refrigerants does not occur when using charging equipment. Hoses or lines shall be as short as possible to minimize the amount of refrigerant contained in them.
- Cylinders shall be kept in an appropriate position according to the instructions.
- Ensure that the refrigerating system is earthed before charging the system with refrigerant.
- Label the system when charging is complete (if not already).
- Extreme care shall be taken not to overfill the refrigerating system.

Prior to recharging the system, it shall be pressure-tested with the appropriate purging gas. The system shall be leak-tested on completion of charging but before commissioning. A follow-up leak test shall be carried out before leaving the site.

1.5.15 Decommissioning

Before conducting this procedure, it is essential that the technician is completely familiar with the equipment and all its detail. It is recommended good practice that all refrigerants are recovered safely. Before the task is conducted, an oil and refrigerant sample shall be taken in case analysis is required before re-use of recovered refrigerant. It is essential that electrical power is available before the task commences.

- a. Become familiar with the equipment and its operation.
- b. Isolate system electrically.
- c. Before performing the procedure, ensure that:
 - Mechanical handling equipment is available, if required, for handling refrigerant cylinders.
 - All personal protective equipment is available and being used correctly.
 - The recovery process is always supervised by a competent person.
 - Recovery equipment and cylinders conform to the appropriate standards.
- d. Pump down refrigerant system, if possible.
- e. If a vacuum is not possible, make a manifold so that refrigerant can be removed from various parts of the system.
- f. Make sure that cylinder is situated on the scales before recovery takes place.
- g. Start the recovery machine and operate following the instructions.
- h. Do not overfill cylinders (no more than 80 % volume liquid charge).
- i. Do not exceed the maximum working pressure of the cylinder, even temporarily.
- j. When the cylinders have been filled correctly and the process completed, make sure that the cylinders and the equipment are removed from site promptly and all isolation valves on the equipment are closed off.
- k. Recovered refrigerant shall not be charged into another refrigerating system unless it has been cleaned and checked.

1.5.16 Labeling

Equipment shall be labelled to indicate that it has been de-commissioned and emptied of refrigerant. The label shall be dated and signed. For appliances containing flammable refrigerants, ensure that there are labels on the equipment stating the equipment contains flammable refrigerant.

1.5.17 Recovery

When removing refrigerant from a system, either for servicing or decommissioning, it is recommended good practice that all refrigerants are removed safely.

When transferring refrigerant into cylinders, ensure that only appropriate refrigerant recovery cylinders are employed. Ensure that the correct number of cylinders for holding the total system charge is available. All cylinders to be used are designated for the recovered refrigerant and labelled for that refrigerant (i.e. Special cylinders for the recovery of refrigerant). Cylinders shall be complete with pressure-relief valve and associated shut-off valves in good working order. Empty recovery cylinders are evacuated and, if possible, cooled before recovery occurs.

The recovery equipment shall be in good working order with a set of instructions concerning the equipment that is at hand and shall be suitable for the recovery of all appropriate refrigerants including, when applicable, flammable refrigerants. In addition, a set of calibrated weighing scales shall be available and in good working order. Hoses shall be complete with leak-free disconnect couplings and in good condition. Before using the recovery machine, check that it is in satisfactory working order, has been properly maintained and that any associated electrical components are sealed to prevent ignition in the event of a refrigerant release. Consult manufacturer if in doubt.

The recovered refrigerant shall be returned to the refrigerant supplier in the correct recovery cylinder, and the waste transfer note arranged. Do not mix refrigerants in recovery units and especially not in cylinders.

USA and Canada. The recovered refrigerant shall be processed according to local legislation in the correct recovery cylinder, and the waste transfer note arranged. Do not mix refrigerants in recovery units and especially not in cylinders.

If compressors or compressor oils are to be removed, ensure that they have been evacuated to an acceptable level to make certain that flammable refrigerant does not remain within the lubricant. The evacuation process shall be conducted before returning the compressor to the supplier. Only electric heating to the compressor body shall be employed to accelerate this process; the compressor body shall not be heated by an open flame or other ignition sources. When oil is drained from a system, it shall be conducted safely.

This page intentionally left blank

2 Product Overview

The Vertiv™ CoolPhase Wall is a wall-mounted split system (3.5, 7, and 11 kW) specifically created and designed for small technical rooms, server rooms, and Edge Computing Applications, with R32 as the refrigerant.

It is a wall mounted type unit, designed for cooling IT equipment, featuring high reliability, it can maintain a favorable environment rooms, where comfort cooling is lacking.

Standard features include fan with infinitely adjustable speed, small diameter tube HEX to minimize refrigerant charge, wall mounted display and Remote monitoring through SNMP, HTTP, BACnet and Modbus.

2.1 Model Nomenclature

Vertiv CoolPhase Wall has three models: WLM030A, WLM070A, and WLM110A. The following **Table 2.1** below describes the model number for the Vertiv CoolPhase Wall cooling units.

Table 2.1 Model Number Descriptions for the Vertiv CoolPhase Wall

SKU	Description	Vertiv™ CoolPhase Condensing Unit	
WLM030A	Vertiv CoolPhase Wall 3.5KW Indoor 208 / 230V / 1Ph / 50/60Hz ETL/CE UKCA	Works with	CUD030-E000A CUL030-E000A
WLM070A	Vertiv CoolPhase Wall 7KW Indoor 208 / 230V / 1Ph / 50/60Hz ETL/CE UKCA		CUD070-E000A CUL070-E000A
WLM110A	Vertiv CoolPhase Wall 11KW Indoor 208 / 230V / 1Ph / 50/60Hz ETL/CE UKCA		CUD111-E000A CUL111-E000A CUD115-E000A CUL115-E000A

Table 2.2 Model Number

1	2	3	4	5	6	7
W	L	M	0	3	0	A

Figure 2.1 Models Nomenclature

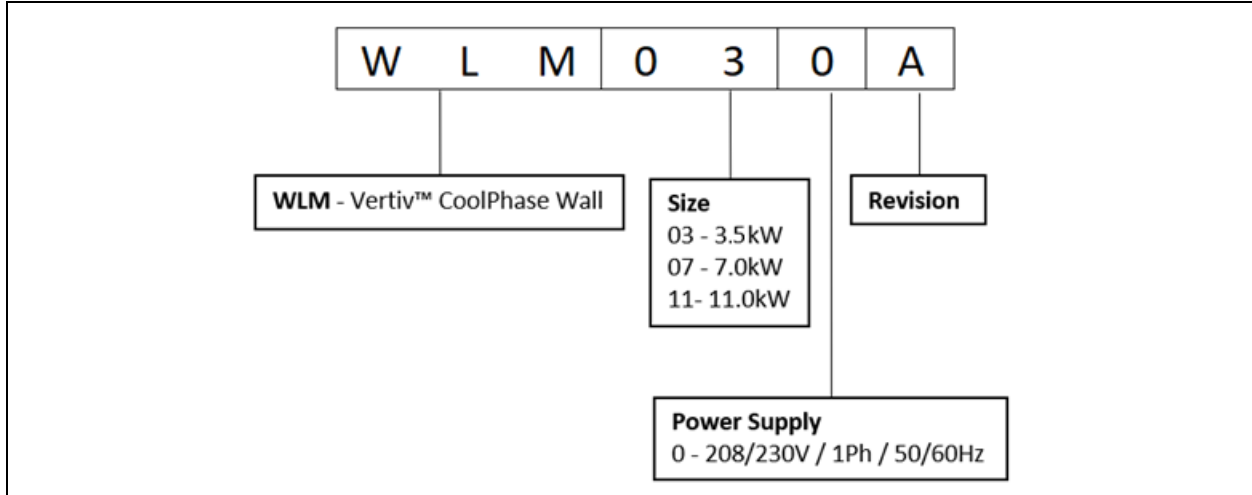

Table 2.3 Vertiv™ CoolPhase Wall Model-number Digit Definitions

Digit	Description
Digits 1 - 3	Unit family: WLM – Vertiv CoolPhase Wall
Digits 4 - 5	Size: 03 = 3.5 kW 07 = 7 kW 11 = 11 kW
Digit 6	Power supply: 0 - 208/230 / 1 Ph / 50/60 Hz
Digit 7	Revision: A - Revision A

Table 2.4 Vertiv CoolPhase Wall Technical Description

	WLM030A	WLM070A	WLM110A
Return air condition:	80°F (26.6°C) RAT, 35% RH		
Sensible cooling capacity (kW)	3.7	7.0	11
Sensible heat ratio	≥ 0.9	≥ 0.9	≥ 0.9
Region	Global		
Number of fans	1	2	3
Rated power	145	265	450
Certification	cETLus, CE & UKCA		

Table 2.4 Vertiv CoolPhase Wall Technical Description (continued)

		WLM030A	WLM070A	WLM110A
Refrigerant connection		Flare connection		
Controls		Vertiv™ Liebert® iCOM™ Edge Controller, automatic startup		
		Unity card		
Power supply		208/230V / 1ph / 50/60Hz		
Noise dB(A) at 2m		≤ 69	≤ 71	≤ 74
Indoor operating range		20 °C (68 °F) to 30 °C (86 °F), 15% RH to 70% RH @ 30 °C (86 °F)		
Air Flow (CFM)/(m3/h)		600 (1050)	1200 (2000)	1800 (3100)
Max equivalent piping length ft (m)		Max. 197 ft (60 m)		
Height between indoor unit and condensing unit	Condensing unit position higher than indoor unit	98.43 ft (30 m)		
	Condensing unit position lower than indoor unit	-26.25 ft (-8m)		
Refrigerant		R32 (GWP 675)	R32 (GWP 675)	R32 (GWP 675)
Options / accessories		Condensate pump kit		
Air filter: The air filter is a washable PP mesh pre-filter designed for the removal of coarse dust and large particles. It is not intended for fine filtration and does not have a defined filtration efficiency rating.				

NOTE: The operating limits refer to new units and those that have been correctly installed and serviced.

2.2 Nameplate

Figure 2.2 Nameplate Location

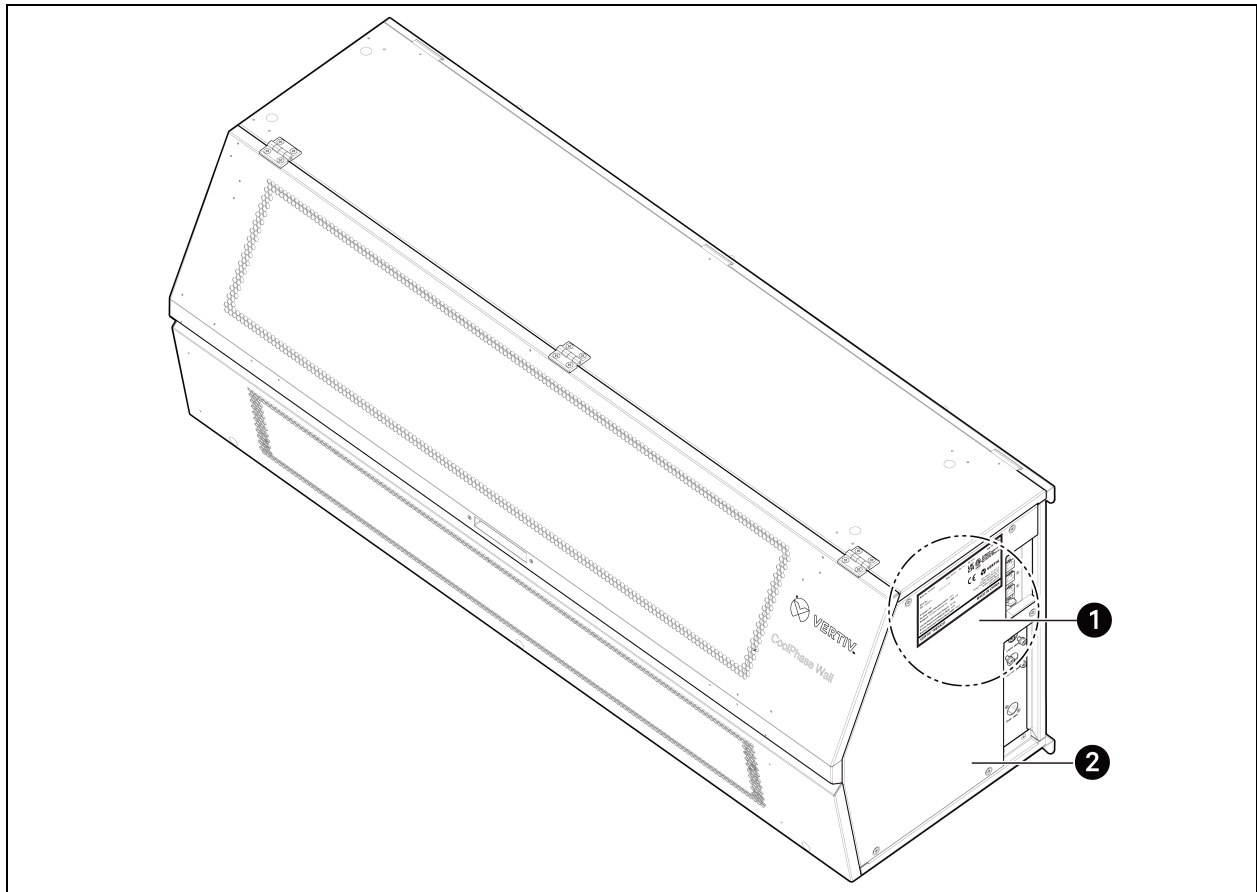

Item	Description
1	Nameplate
2	E-box on the right-side panel of the indoor unit

2.3 Components Location

Figure 2.4 Vertiv™ CoolPhase Wall Component Location

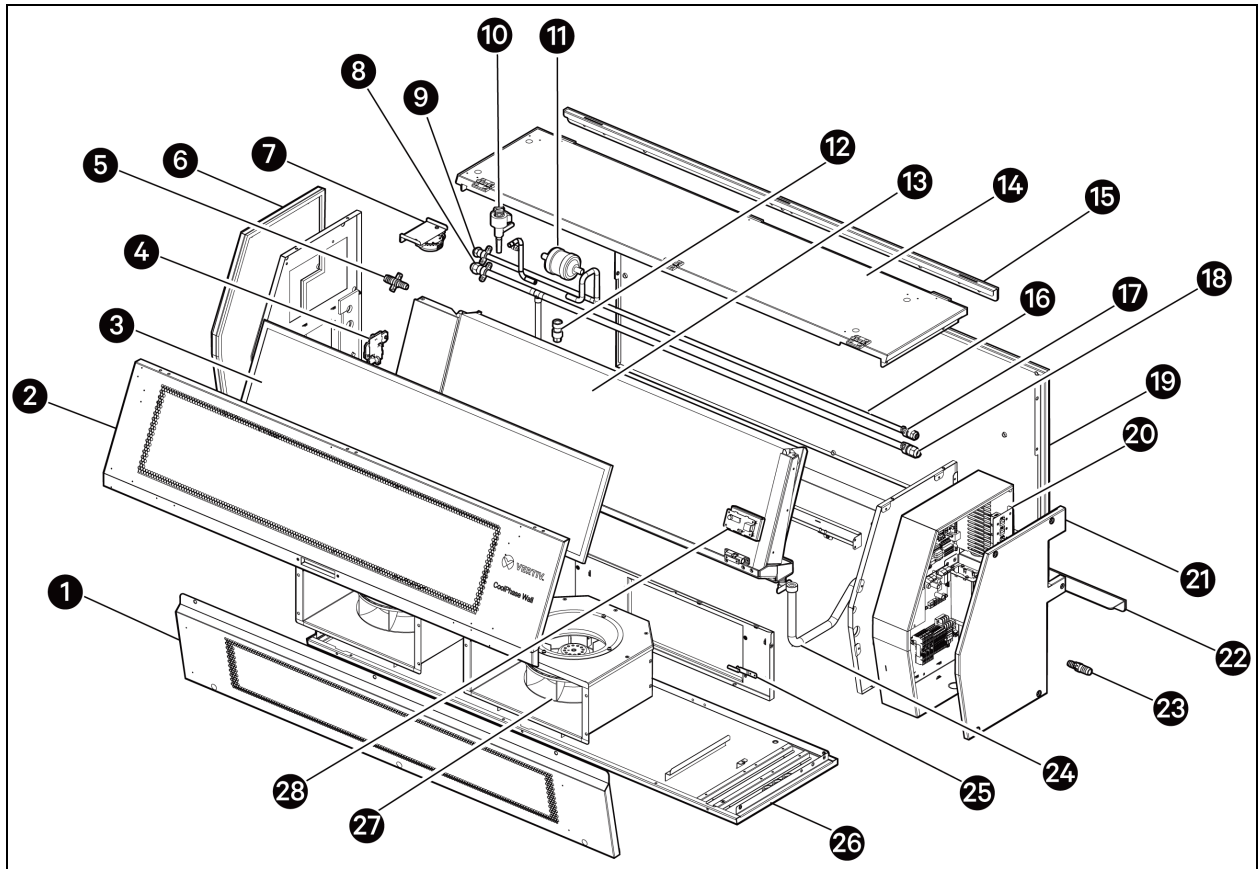

Item	Description	Item	Description
1	Air supply cover	15	Upper mounting bar
2	Return air cover	16	Refrigerant pipe
3	Air filter	17	Refrigerant liquid connector - right
4	High water level detection board	18	Refrigerant suction connector - right
5	Drain connector – left	19	Back cover
6	Left outer cover	20	E-box
7	Refrigerant leak sensor	21	Right outer cover
8	Refrigerant suction connector – left	22	Lower mounting bar
9	Refrigerant liquid connector – left	23	Drain connector - right
10	EEV	24	Drain pipe
11	Filter drier	25	Supply air temperature sensor

Item	Description	Item	Description
12	Low pressure transducer	26	Bottom cover
13	Evaporator coil	27	Evaporator fans
14	Top cover	28	Return air detection board

2.4 Accessories

The optional accessory available for the indoor unit is listed below. Refer to [Condensate Pump Kit Connection](#) on page 52 for further information.

WLMPMP KIT	Vertiv™ CoolPhase Wall Condensate Pump Kit
------------	--

2.5 Dimensions and Weights

Figure 2.5 Indoor Unit Dimension

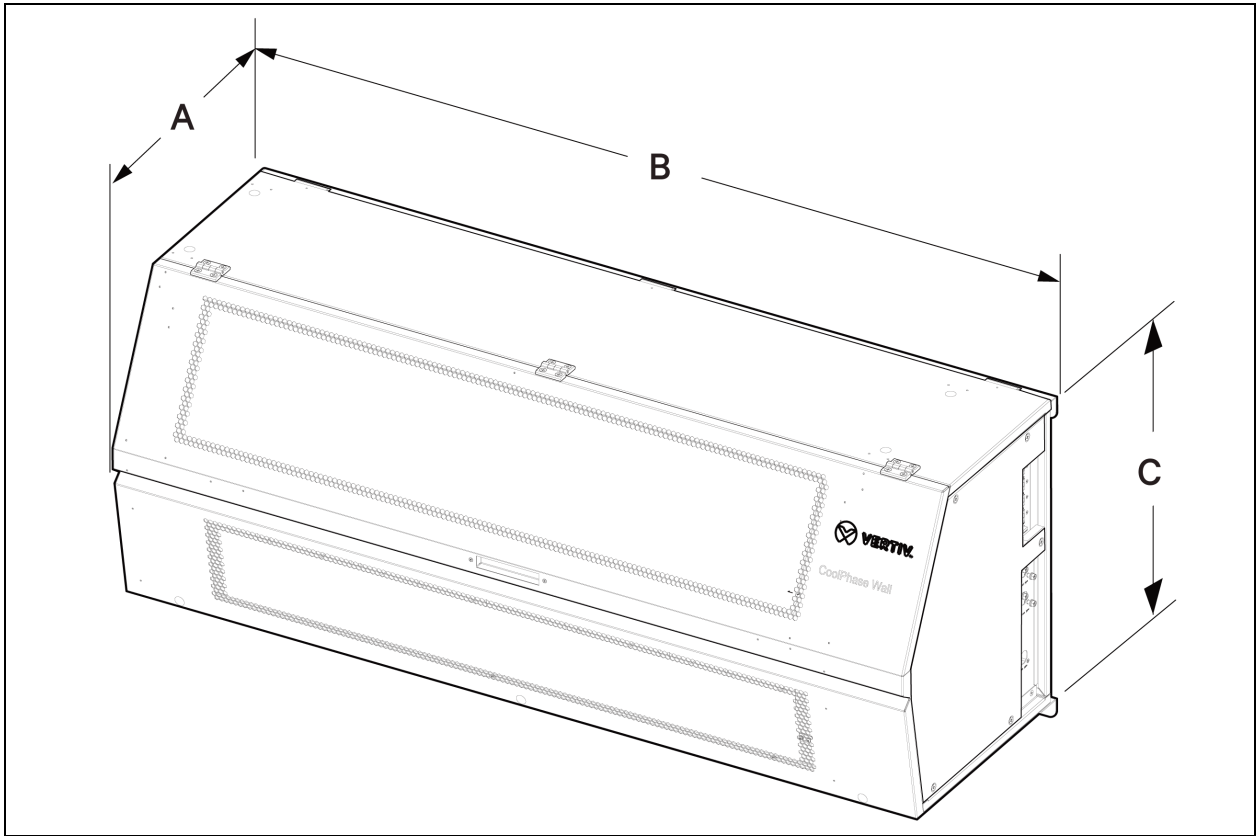

Table 2.5 Indoor Unit Dimensions and Weight

Model	Unit Dimensions in (mm)			Depth	Width	Height	Net Weight lb (kg)	Shipping Weight lb (kg)
	Depth (A)	Width (B)	Height (C)					
WLM030A	15.35 (390)	36.02 (915.0)	19.29 (490.0)	20.87 (530.0)	42.13 (1070.0)	25.98 (660.0)	91.49 (41.5)	112.44 (51.0)
WLM070A		49.80 (1265.0)			55.86 (1419.0)		120.15 (54.5)	147.71 (67.0)
WLM110A		56.10 (1425.0)			62.40 (1585.0)		144.40 (65.5)	178.57 (81.0)

2.6 Storage Environment

Table 2.6 Storage Environment

Item	Requirements
Storage environment	Store the unit in its original factory packaging, in a clean indoor environment with good ventilation and with no dust
Ambient temperature	-40 °C to +70 °C (-40 °F to +158 °F)
Ambient humidity	Less than 95% RH @ 30°C (86 °F)

2.7 Electrical Data

Table 2.7 Unit Electrical Data

Model	Indoor Unit Fan (A)	MCA (A)	MOP (A)	FLA (A)
WLM030A	1.3	3	15	2
WLM070A	2.6	4	15	3
WLM110A	3.9	5	15	5

NOTE: When the indoor unit is powered by the outdoor unit, the overall MCA, MOP, and FCA values are provided in **Table 6.2** on page 61.

2.8 Vertiv™ CoolPhase Wall on Structure Wall Intended Application

The Vertiv CoolPhase Wall unit is a wall mounted type unit, designed for cooling IT equipment, featuring high reliability, it can maintain a favorable environment rooms, where comfort cooling is lacking. Provide precise temperature control for servers to ensure efficient operation of IT equipment.

The Vertiv CoolPhase Wall has some technical features:

1. Efficient cooling ability, large airflow, low power consumption.
2. Precise supply temperature control $\pm 1^{\circ}\text{C}$ deviation and air cooling.
3. Reliable and continuous cooling system.
4. Low global warming influence.
5. Wide operation range.
6. Support teamwork and fault warning.

Figure 2.6 Example of Application

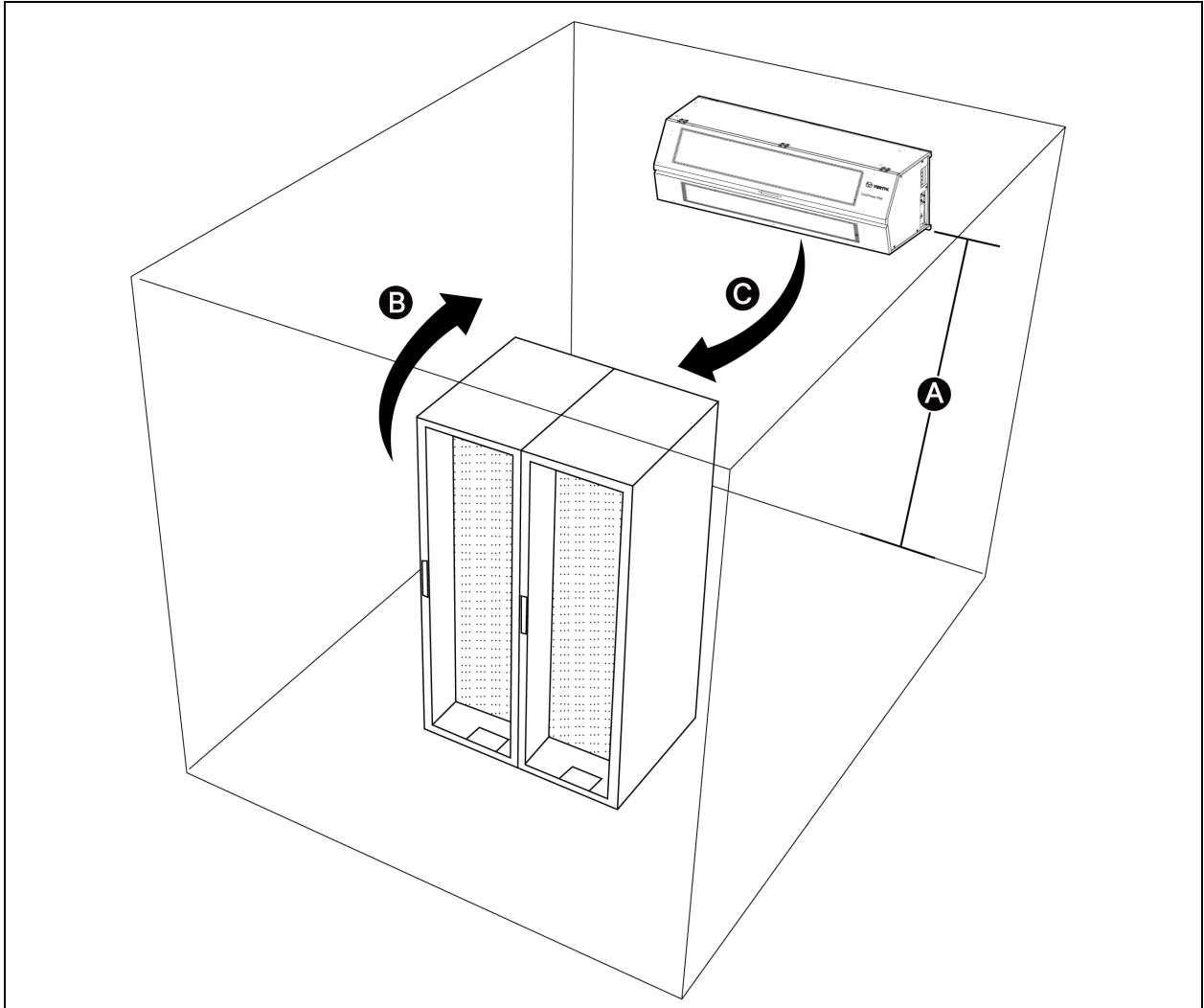

Item	Opening - Description mm (in.)	Item	Opening - Description mm (in.)
A	Height: ≥ 5.9 ft (1.8 m)	C	Cooling supply airflow
B	Warming return airflow		

3 Pre-installation Preparation



WARNING! Risk of top-heavy unit falling over. Improper handling can cause equipment damage, injury or death. Read all of the following instructions and verify that all lifting and moving equipment is rated for the weight of the unit before attempting to move, lift, remove packaging from or prepare the unit for installation.



CAUTION: Risk of contact with sharp edges, splinters, and exposed fasteners. Can cause injury. Only properly trained and qualified personnel wearing appropriate, OSHA-approved PPE should attempt to move, lift, remove packaging from or prepare the unit for installation.

NOTICE

Risk of damage from forklift, can cause unit damage. Keep tines of the forklift level and at a height suitable to fit below the skid and/or unit to prevent exterior and/or underside damage.

NOTICE

Risk of improper storage. Keep the unit in its original package, upright, indoors and protected from dampness, freezing temperatures and contact damage.

3.1 Tools Required

The following tools are required to service the refrigerant circuit (and are not provided with the unit) in compliance with the Safety Classification A2L:

- Refrigerant Gauge manifold
- Refrigerant leak detection
- Vacuum pump
- Refrigerant reclamation unit
- Reclamation holding tank

3.2 Clearance Requirements

Follow recommended practices when choosing an indoor location for the wall-mounted indoor unit:

- Keep unit away from any indoor steam or excessive heat.
- No obstacles should be placed around the unit.
- Condensation drain (leakage piping) should be routed away from the unit.
- Do not install near a doorway.

When planning the position and location of the equipment, refer to **Figure 3.1** on the next page, for the required clearances for installation and service of the installed equipment.

The minimum installation distance of the unit front and sides should be at least 23.60 in (600 mm). A minimum of 3.94 in (100 mm) must be kept between the top of the unit and the ceiling.

Figure 3.1 Vertiv™ CoolPhase Wall Clearance Requirements (Side and Isometric View).

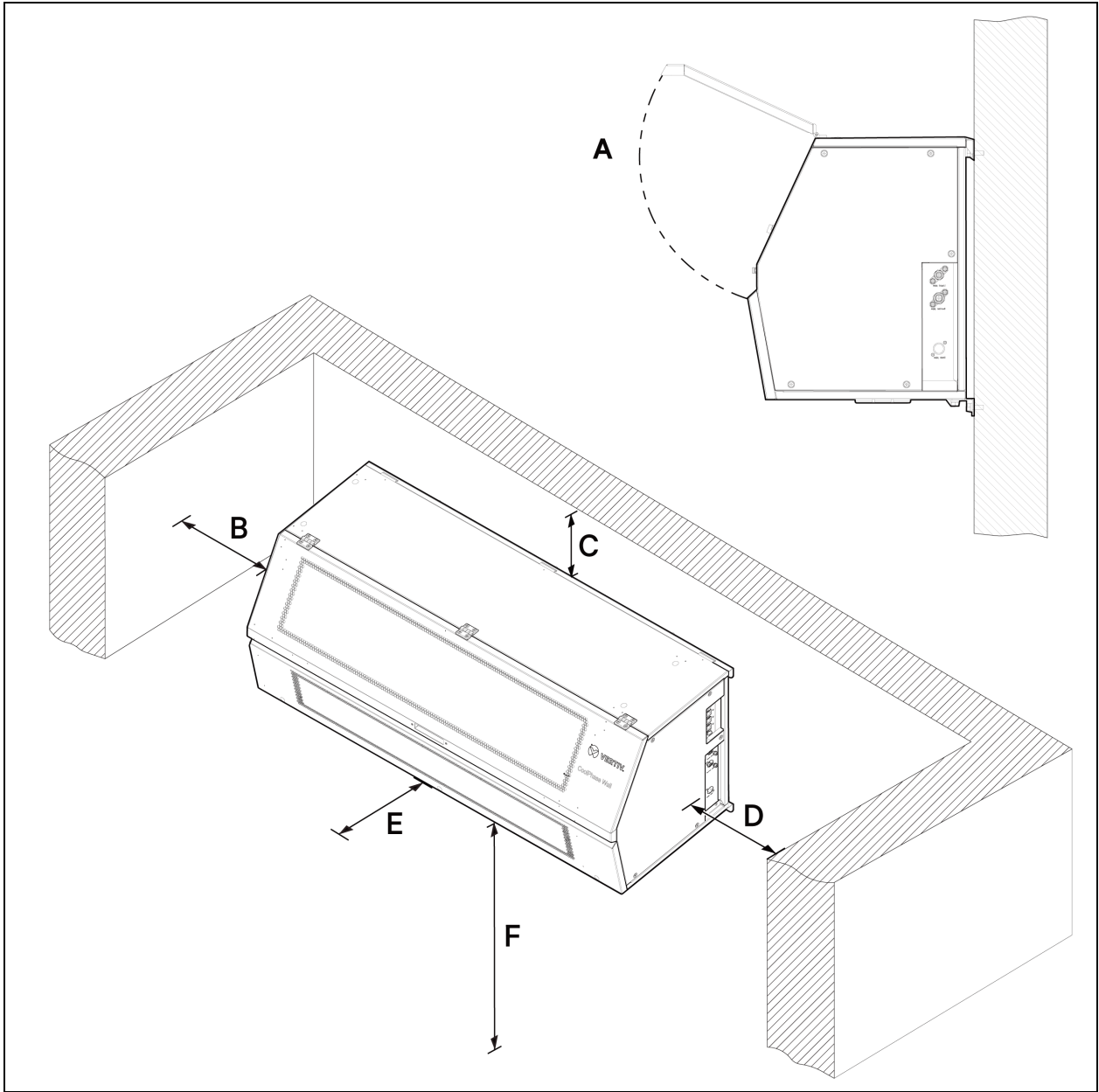

Item	Description	Item	Description
A	Opening clearance: 84.0 degrees	D	Clearance distance: 23.60 in. (600 mm) ¹
B	Clearance distance: 23.60 in. (600 mm) ¹	E	Clearance distance: 23.60 in. (600 mm)
C	Clearance distance: 3.94 in. (100 mm)	F	Minimum height: 5.9 ft (1.8 m) ²

1: The minimal distance between two or more indoor units should be 3.28 ft (1 m) from side to side.
 2: The lowest part of the unit shall be installed higher than the minimum installation height.

3.3 Inspecting the Unit

Upon arrival of the unit and before unpacking:

- Verify that the labeled equipment matches the bill of lading.
- Inspect that there is no visible or concealed damage on the package.
- Additional inspection of the unit is warranted to ensure no exterior or internal damage.

Report damage immediately to the carrier and file a damage claim with a copy sent to Vertiv or to your sales representative.

3.4 Moving the Packaged Unit

NOTE: Before moving, installing, or servicing this unit, please read the Safety Instructions sheet provided as a separate document shipped with the unit.

NOTE: Confirm the safety when lift the unit.

NOTE: Move the unit the closest to the final location.

NOTE: To prevent the unit from falling over, do not tilt the unit more than 22 degrees in any direction.

NOTE: For detailed information on how to move the packaged unit, please refer to the Handling and Unpacking Instructions manual included in the unit packaging.

3.5 Unpacking the Unit

To unpack the Vertiv™ CoolPhase Wall:

1. Put the unit cardboard box on a flat surface and cut along the straps to release the lid.

Figure 3.2 Unpacking the Unit Step 1

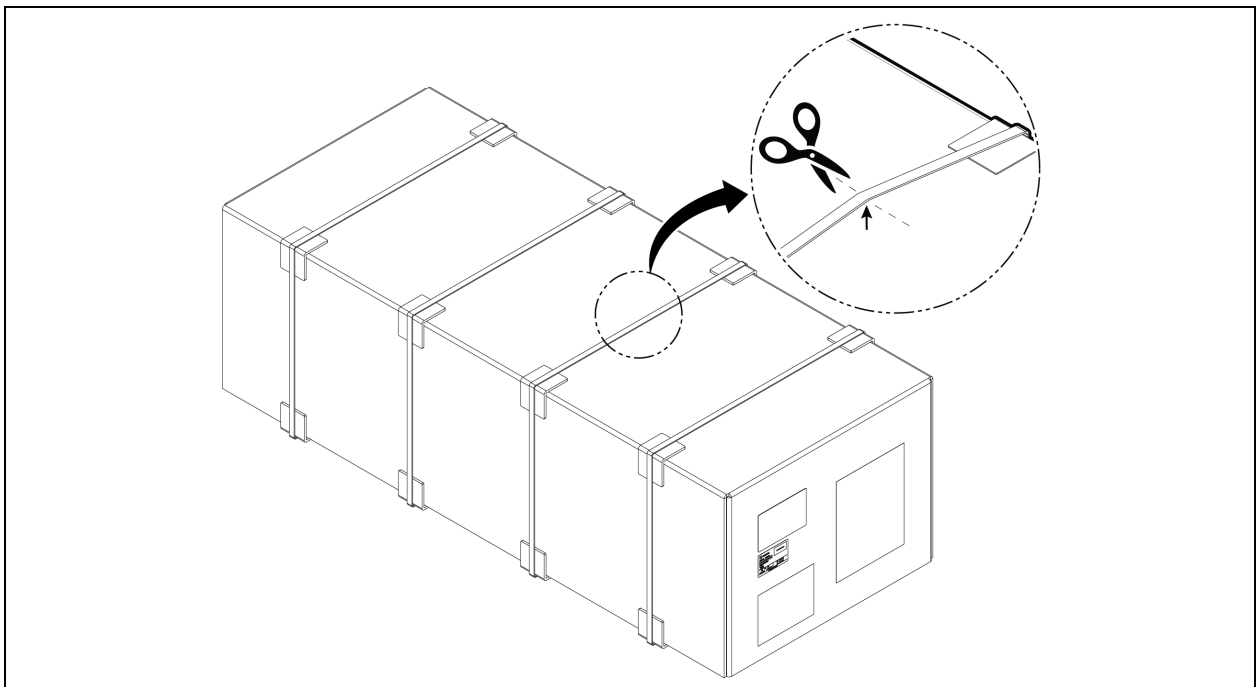

2. Remove the top cardboard cover lid.

Figure 3.3 Unpacking the Unit Step 2

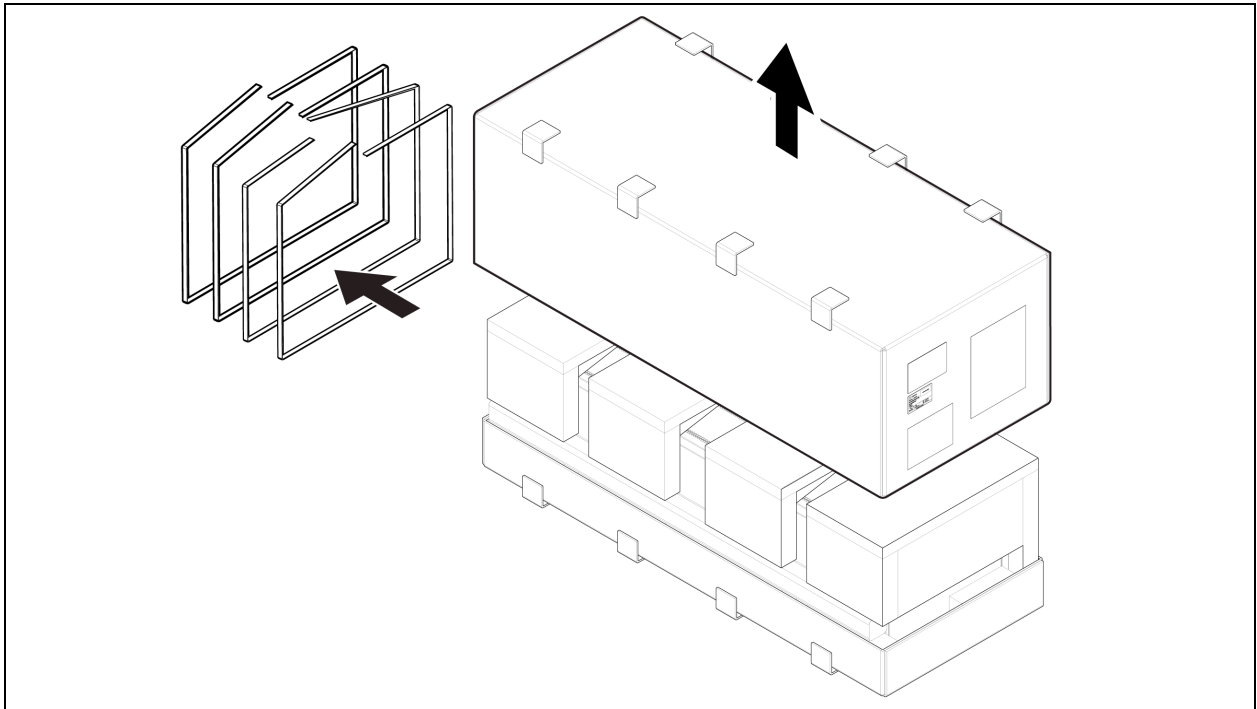

3. Remove the foams that protect the unit, and put aside the accessories:

- M8 x 25 bolts (8 or 10 pieces)
- Mounting board 1 (1 piece)
- Mounting board 2 (1 piece)
- LCD display and cable bag, containing:
 - Display cable (1 piece)
 - LCD display (1 piece)
- Documentation bag, containing:
 - Installation / User Guide (1 piece)
 - Safety statements (1 piece)
 - CE declaration (1 piece)
 - UKCA declaration (1 piece)
 - Production inspection report (1 piece)
- Desiccant bags (2 pieces)

NOTE: These bolts are just as standard configuration. More suitable bolts may be chosen according to the characteristics of the on-site wall.

Figure 3.4 Unpacking the Unit Step 3

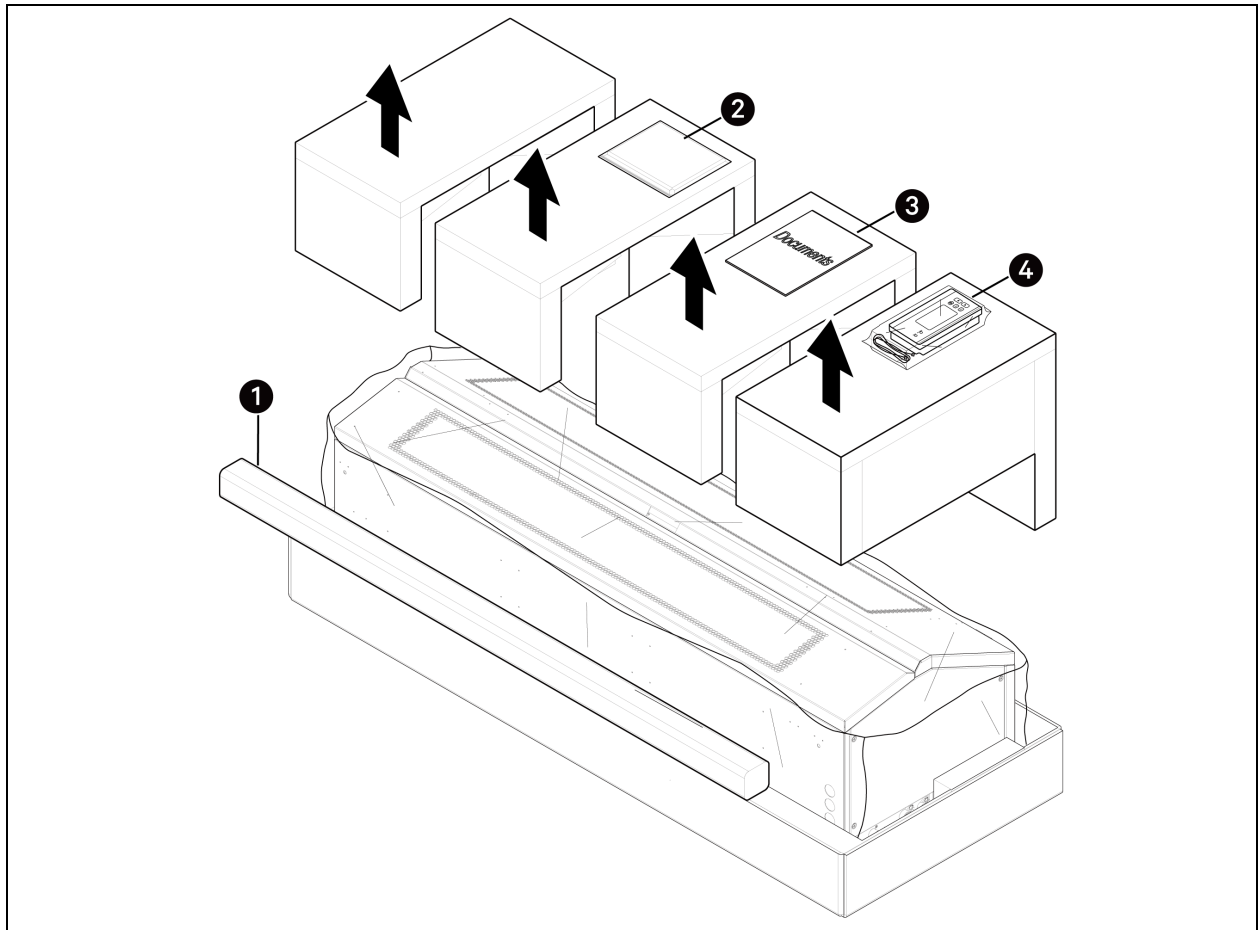

Item	Description	Item	Description
1	Mounting bars (2 pieces)	3	Documentation bag
2	Hardware bag (*)	4	LCD display and cable bag

4. Remove the plastic bag, then take the unit and desiccant bags out of the box.

Figure 3.5 Unpacking the Unit Step 4

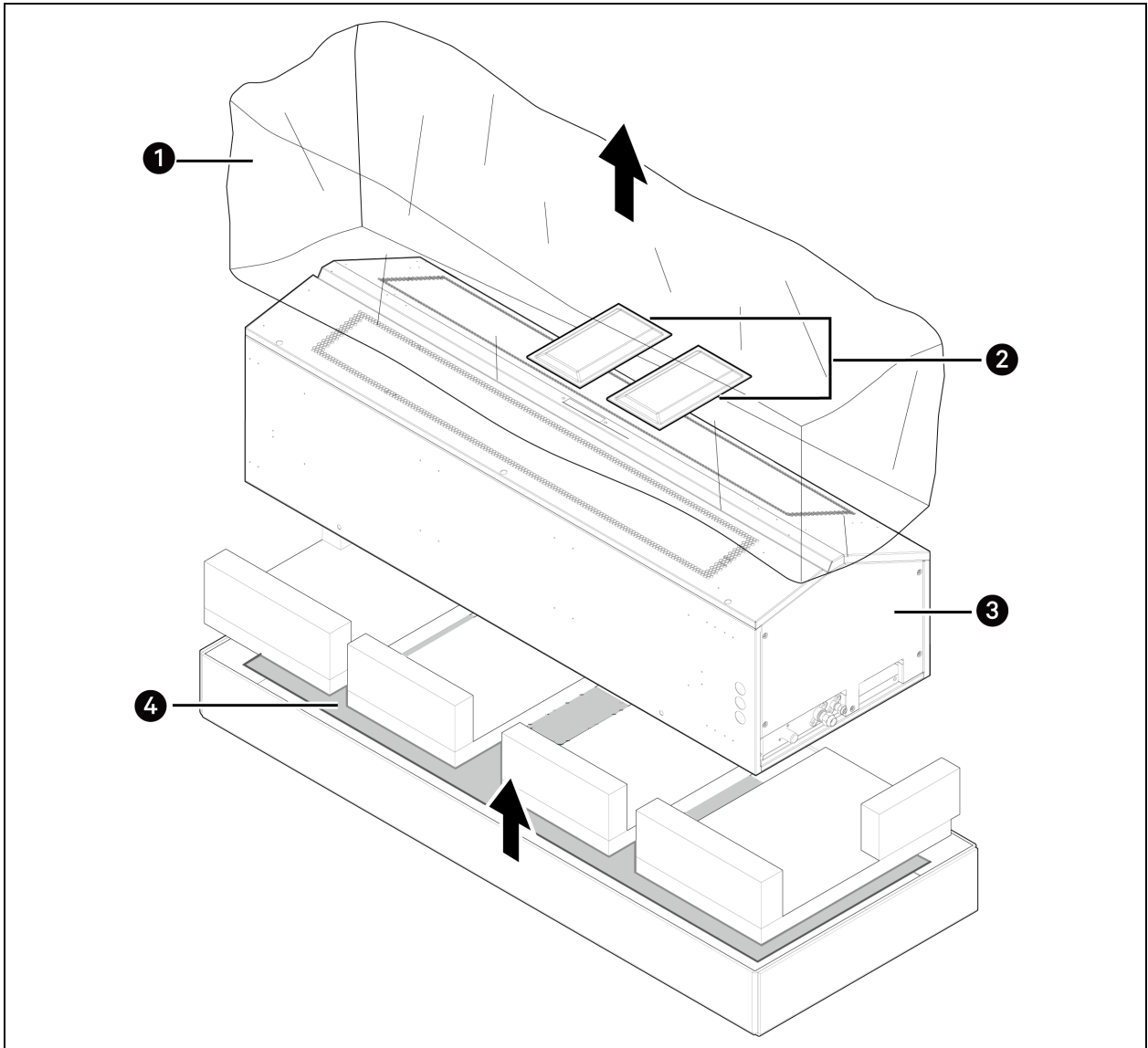

Item	Description	Item	Description
1	Plastic bag	3	Vertiv™ CoolPhase Wallunit
2	Desiccant bags	4	Paper template

4 Installation



WARNING! The appliance is heavy enough to cause serious injuries, the appliance shall be manipulated at least by 2 people or more if required. If necessary, please use the lifting tools, like lifting belt and others.



WARNING! Do not install the appliance on unstable surfaces.



WARNING! Do not mount the appliance where there is a risk of falling.



WARNING! Keep ventilation of the unit clear of any obstruction.



WARNING! Before breaking into the system or conducting any hot work ensure that the working area is open or it is adequately ventilated. Ventilation shall continue during the period that the work is conducted. The ventilation should safely disperse any released refrigerant and preferably expel it externally into the atmosphere.

NOTICE:

Every working procedure that affects safety must be conducted by competent professionals.

The indoor equipment and pipes shall be securely mounted and guarded such that accidental rupture of equipment cannot occur from such events as moving furniture or reconstruction activities.

NOTES:

- Do not use the indoor unit in the open and severe outdoor environment.
- Avoid locating multiple indoor units close to each other that can result in short cycle of air and creating load imbalance. The minimum distance between adjacent units is 3.28 ft (1 m).
- Do not install the unit within the vicinity of any other precision cooling equipment to avoid the leakage of condensed water produced due to imbalance load condition.
- Do not install other devices (such as smoke detector) over the indoor cabinet.
- Avoid locating the indoor unit in concave or narrow areas, which can obstruct the airflow, shorten the cooling cycle and result in air return short cycle and air noise.

Vertiv™ CoolPhase Wall can generate condensate water. Water leakage can cause damage to other equipment nearby. Do not install the units in the vicinity of any precision equipment. The installation site must have the facility of drainage piping.

4.1 Leveling the Unit

NOTE: Considering at least 23.60 in (600 mm) of free space on the sides and 3.94 in (100 mm) on the top side of the equipment. Refer to **Figure 3.1** on page 26. The Vertiv CoolPhase Wall should be installed on a strong vertical surface that can support its weight.

4.2 Installing the Indoor Unit

4.2.1 Installing the Mounting Bars and the Indoor Units



WARNING! Risk of electric shock. Can cause equipment damage, injury, or death. Open all local and remote electric power supply disconnect switches and verify with a voltmeter that power is off before working within any electric connection enclosures. Service and maintenance work must be performed only by professionally trained and qualified personnel and in accordance with applicable regulations and manufacturers' specifications. Opening or removing the covers to any equipment may expose personnel to lethal voltages within the unit even when it is apparently not operating, and the input wiring is disconnected from the electrical source.

NOTE: Follow the installation instructions and utilize the mounting methods described in this manual.

Observe the following guidelines when installing the mounting plate:

- When choosing a location for the mounting bars, be sure to take into consideration routing of wiring for power outlets within the wall.
- Use caution when drilling holes through the walls for the purposes of piping connections.
- Refer to Drilling a Piping Hole in the Wall, as you follow the bars installation procedure.
- Unit must be anchored tightly to a wall that has sufficient strength to support the unit during operation to prevent the unit from falling or creating excessive, unnecessary vibration during operation.
- Use best practices when mounting the indoor unit's mounting bar to a wall.

Figure 4.1 Mounting Bars

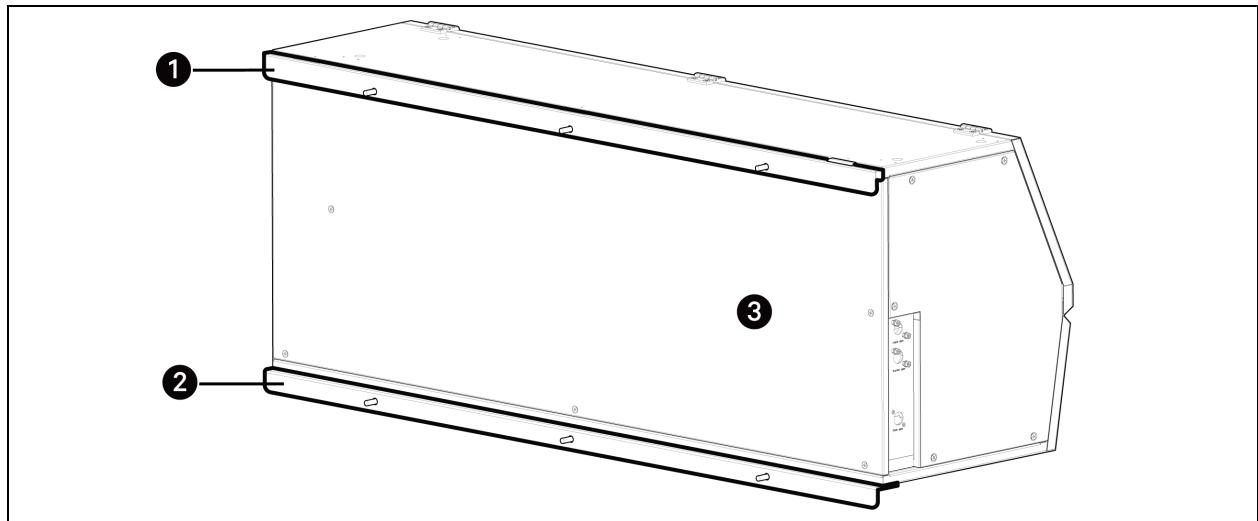

Item	Description	Item	Description
1	Upper mounting bar	3	Back of the indoor unit
2	Lower mounting bar		

Figure 4.2 General Measurement of the Mounting Bars

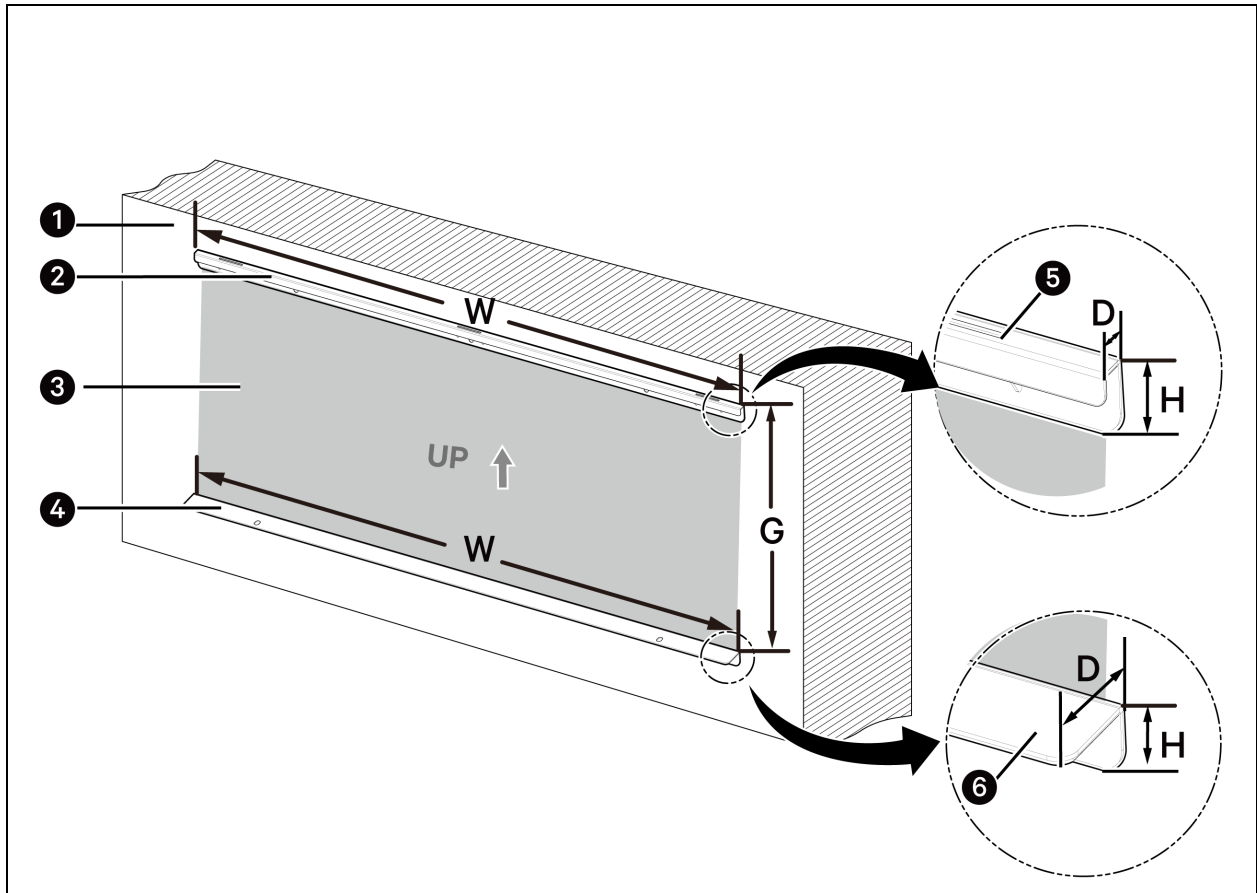

Item	Description	Item	Description
1	Wall	6	Lower mounting bar surface
2	Upper mounting bar	W	Width of upper / lower mounting bar of WLM030A: 915 in. (36.02 mm) Width of upper / lower mounting bar of WLM070A: 1,265 in. (49.80 mm) Width of upper / lower mounting bar of WLM110A: 1,425 in. (56.10 mm)
3	Paper template	H	Height of upper mounting bar: 35 in. (1.38 mm) Height of lower mounting bar: 30 in. (1.18 mm)
4	Lower mounting bar	D	Depth of upper mounting bar: 15 in. (0.59 mm) Depth of lower mounting bar: 50 in. (1.97 mm)
5	Upper mounting bar surface	G	Distance between upper and lower mounting bar surfaces: 19 in. (485 mm)

NOTE: Before installation of the mounting bars, find a suitable location on the wall to drill holes, which support the weight of the indoor unit.

NOTE: Before installing the upper mounting bar, ensure that the screw holes on both the mounting bar and the wall are correctly positioned and perfectly aligned. Use a leveling tool to verify proper alignment.

NOTE: Prior to mounting the Vertiv™ CoolPhase Wall, redirect the piping to the desired location according to the field connection.

NOTE: The number of fixing screw holes on the upper and lower mounting bars, as well as the number of mounting slots on the upper mounting bar, varies with the unit model.

NOTE: Select the appropriate M8x25 bolts according to the surface where the indoor unit is going to be mounted.

To install the indoor unit:

1. Position the paper template on the wall, and then drill M8 holes at the indicated locations (the blue holes on the template).

Figure 4.3 Positioning Paper Template and Drilling M8 Holes

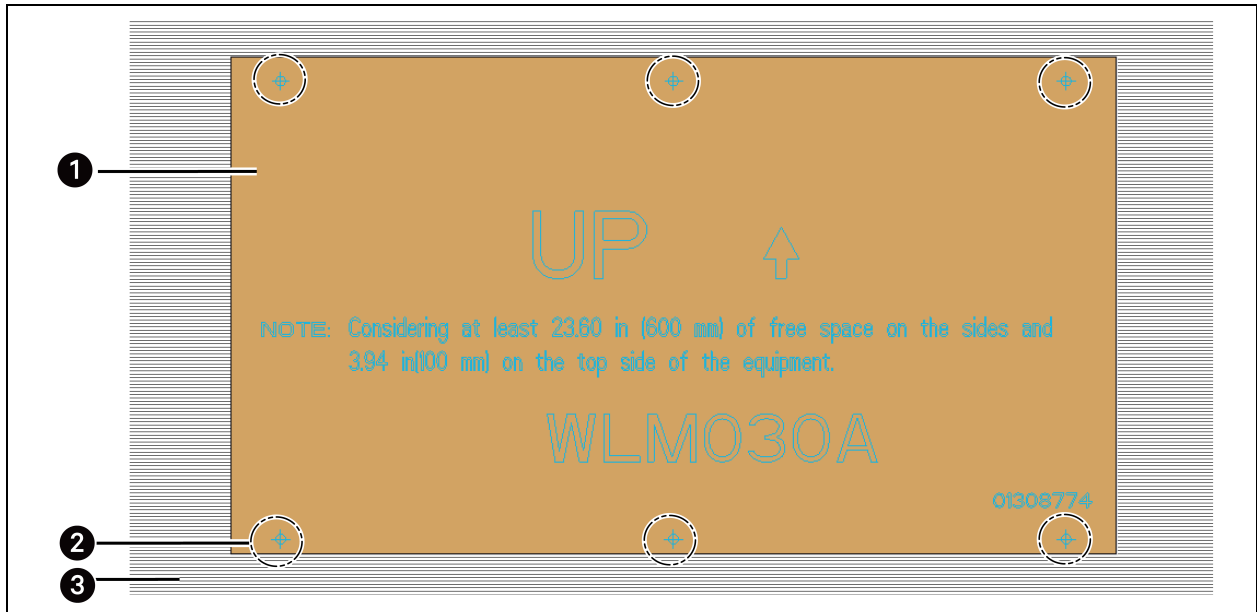

Item	Description	Item	Description
1	Paper template	3	Wall
2	Indicated location (blue hole on the paper template)		

2. Install the upper mounting bar and lower mounting bar to the wall using the M8 bolts. After fastening the upper and lower mounting bars, remove the paper template.

Figure 4.4 Installing the Upper and Lower Mounting Bars

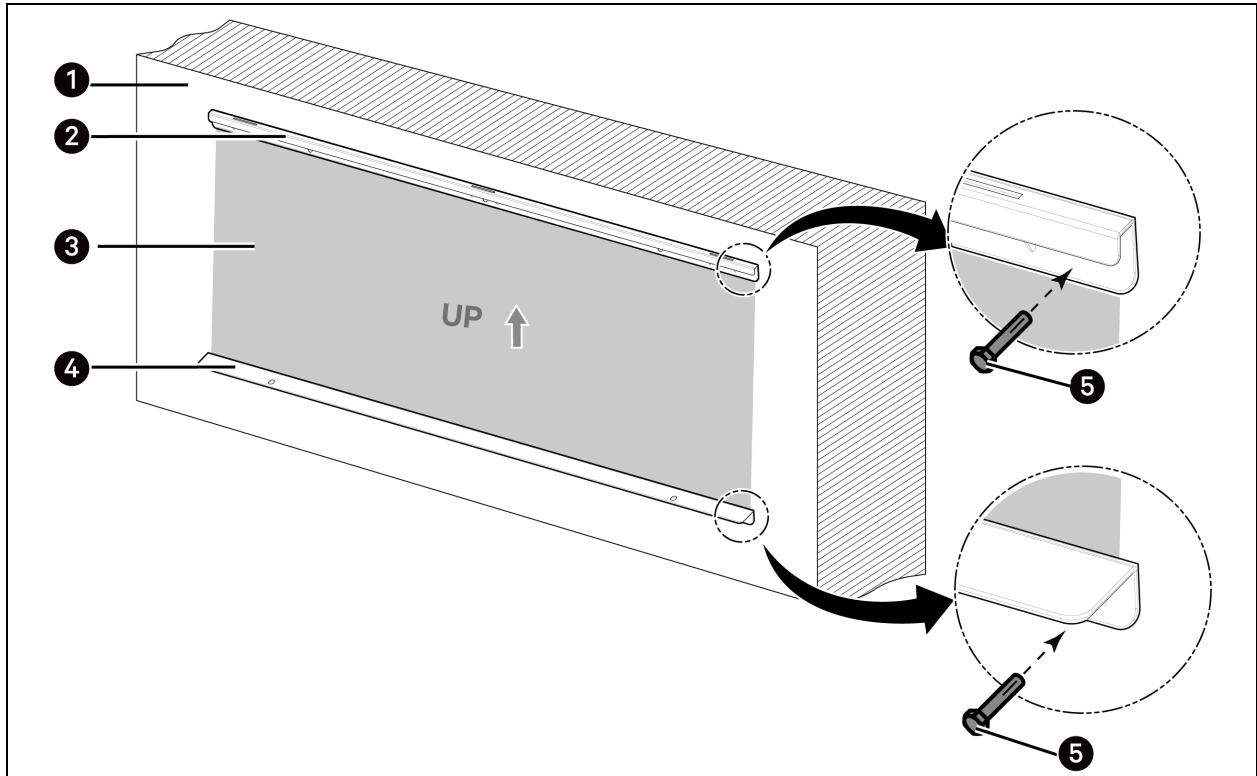

Item	Description	Item	Description
1	Wall	4	Lower mounting bar
2	Upper mounting bar	5	M8 bolts
3	Paper template		

3. First hang the unit on the upper mounting bar, and then seat it onto the lower mounting bar.

Figure 4.5 Mounting the Unit on Upper Bar and Seating on Lower Bar

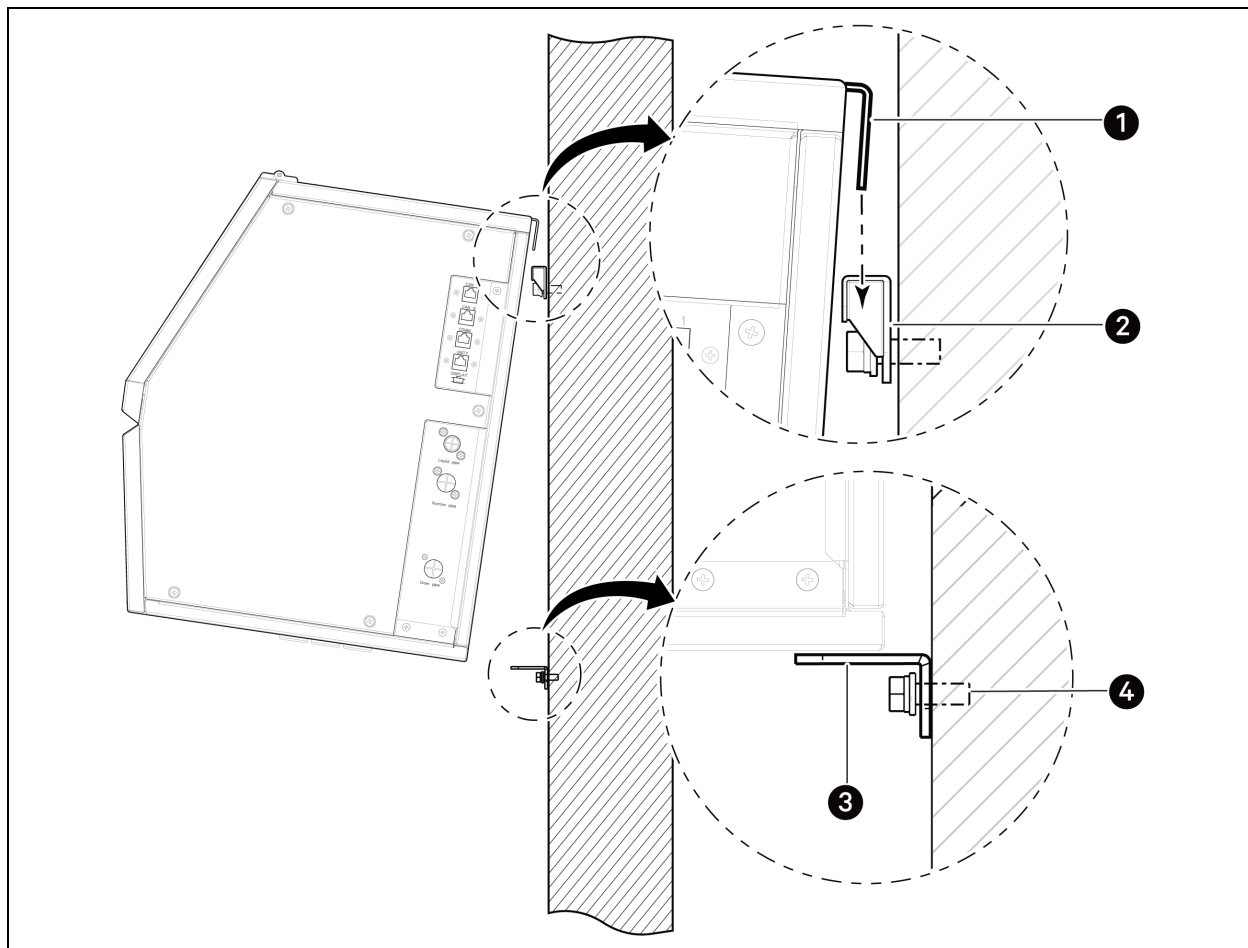

Item	Description	Item	Description
1	Indoor unit brackets	3	Lower mounting bar (side view)
2	Upper mounting bar (side view)	4	M8 x 25 bolts

4. Fasten the unit to the lower mounting bar with M8 bolts.

Figure 4.6 Fastening the Unit to the Lower Mounting Bar

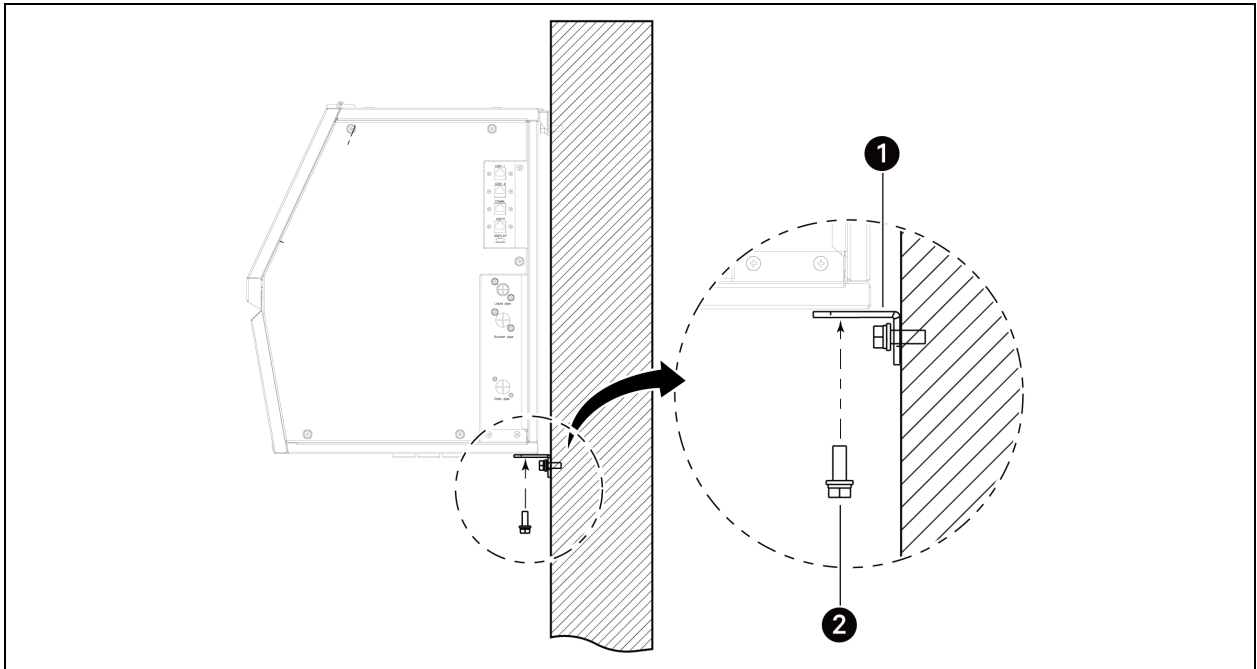

Item	Description
1	Lower mounting bar (side view)
2	M8 x 25 bolts

NOTE: Make sure the upper and lower mounting bars are tightly installed.

NOTE: Use caution when drilling holes through the walls.

NOTE: Make sure the indoor unit is properly seated on the installation bar by moving the unit left and right.

4.2.2 Drilling a Piping Hole in the Wall

1. Using 3.5 in (89 mm) or bigger hole-core drill bits, drill a hole at either the right or left side of the wall mounting, **Figure 4.7** below.
 - The slant of the hole should be 3/16 in (4.8 mm) to 5/16 in (7.9 mm) from level with an upward slant on the indoor unit side and downward on the outdoor unit side.
2. Finish off the newly drilled hole as shown in the **Figure 4.7** below , with a bushing and sleeve covering.
 - The sleeve and bushing (not included) prevent damage to the tubing/bundling of the piping.

Figure 4.7 Drilling a Piping Hole

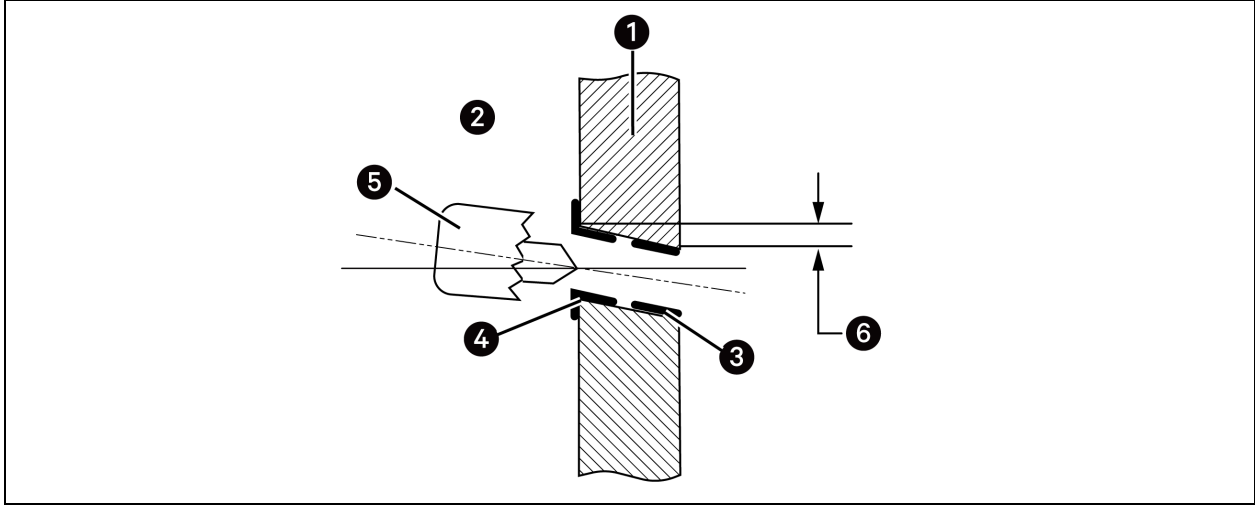

Item	Description	Item	Description
1	Wall	4	Bushing (not included)
2	Indoor environment	5	Core Drill
3	Sleeve (not included)	6	4.8 mm (3/16 in.) to 7.9 mm (5/16 in.)

5 Piping Connection

5.1 General Connections

5.1.1 Notes and Warnings



WARNING! Before breaking into the system or conducting any hot work ensure that the working area is open or it is adequately ventilated. Ventilation shall continue during the period that the work is conducted. The ventilation should safely disperse any released refrigerant and preferably expel it externally into the atmosphere.



WARNING! Under no circumstances potential sources of ignition shall be used in the searching for or detection of refrigerant leaks. A halide torch (or any other detector using a naked flame) shall not be used.



WARNING! If a leakage of refrigerant is found which requires brazing, all the refrigerant shall be recovered from the system, or isolated (by means of shut off valves) in a part of the system remote from the leak. Removal of refrigerant shall be performed following manufacturer instructions.



WARNING! Electronic leak detectors with the appropriate sensitivity must be used, equipment shall be calibrated to the refrigerant employed. Electronic leak detectors shall not be potential ignition sources and shall be suitable for the refrigerant used. Leak detection equipment shall be set to an appropriate percentage of the Lower Flammability Limit of the refrigerant not exceeding the 25% of the LFL.

NOTE: Before starting with piping connections, review the Important Safety Instruction chapter of this manual and review the piping connection chapter of condensing unit.

NOTICE

The length of the pipe shall be considered when filling the system with refrigerant, refer to **Table 8.2** on page 75 for more details about the pipe length, total refrigerant charge.

NOTICE

When removing refrigerant from a system it is recommended good practice that all refrigerants are removed safely.



WARNING! Risk of over-pressurization of the refrigeration system. Can cause explosive discharge of high-pressure refrigerant, loss of refrigerant, environmental pollution, equipment damage, injury, or death. This unit contains fluids and gases under high pressure. Use extreme caution when charging the refrigerant system. Do not pressurize the system higher than the design pressure marked on the unit's nameplate.



CAUTION: Risk of excessive refrigerant line pressure. Can cause tubing and component rupture resulting in equipment damage and personal injury. Do not close off the refrigerant-line isolation valve for repairs unless a pressure-relief valve is field- installed in the line between the isolation valve and the check valve. The pressure-relief valve must be rated 5% to 10% higher than the system-design pressure. An increase in ambient temperature can cause the pressure of the isolated refrigerant to rise and exceed the system-design pressure rating (marked on the unit nameplate).

NOTICE

Risk of oil contamination with water can cause equipment damage. Vertiv™ CoolPhase Wall systems require the use of FW68S oil. Because water is the enemy of a reliable refrigeration system, extreme care must be used when opening systems during installation or service. Even though FW68S oil absorbs water at a much slower rate when exposed to air than previously used oils. If water is absorbed into the FW68S oil, it will not be easily removed and will not be removed through the normal evacuation process. If the oil is too wet, it may require an oil change and a deep vacuum to remove moisture. FW68S oils also have a property that makes them function as a solvent in a refrigeration system. Maintaining system cleanliness is extremely important because the oil will tend to bring any foreign matter back to the compressor.

5.1.2 General Arrangement

Figure 5.1 General Arrangement Diagram

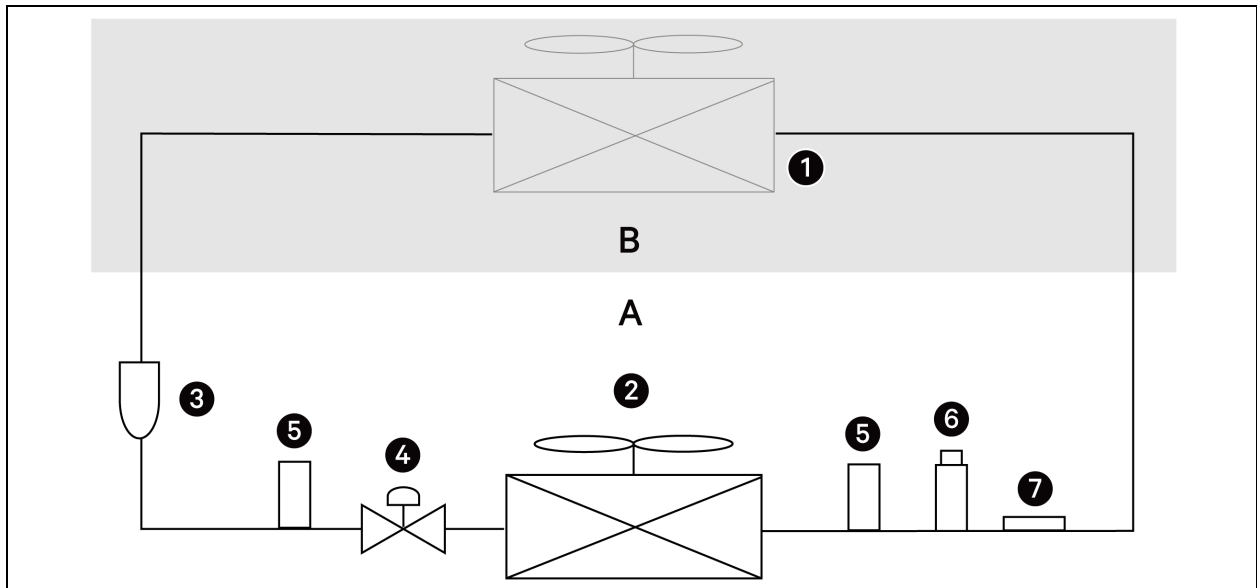

Item	Description	Item	Description
A	Indoor	4	Electronic expansion valve
B	Outdoor / plenum	5	Schrader service valve with core
1	Condensing unit	6	Low pressure transducer
2	Evaporator coil	7	Suction temperature sensor
3	Filter drier		

Figure 5.2 Location and Dimension of Pipe and Cable Outlets on Side Plate

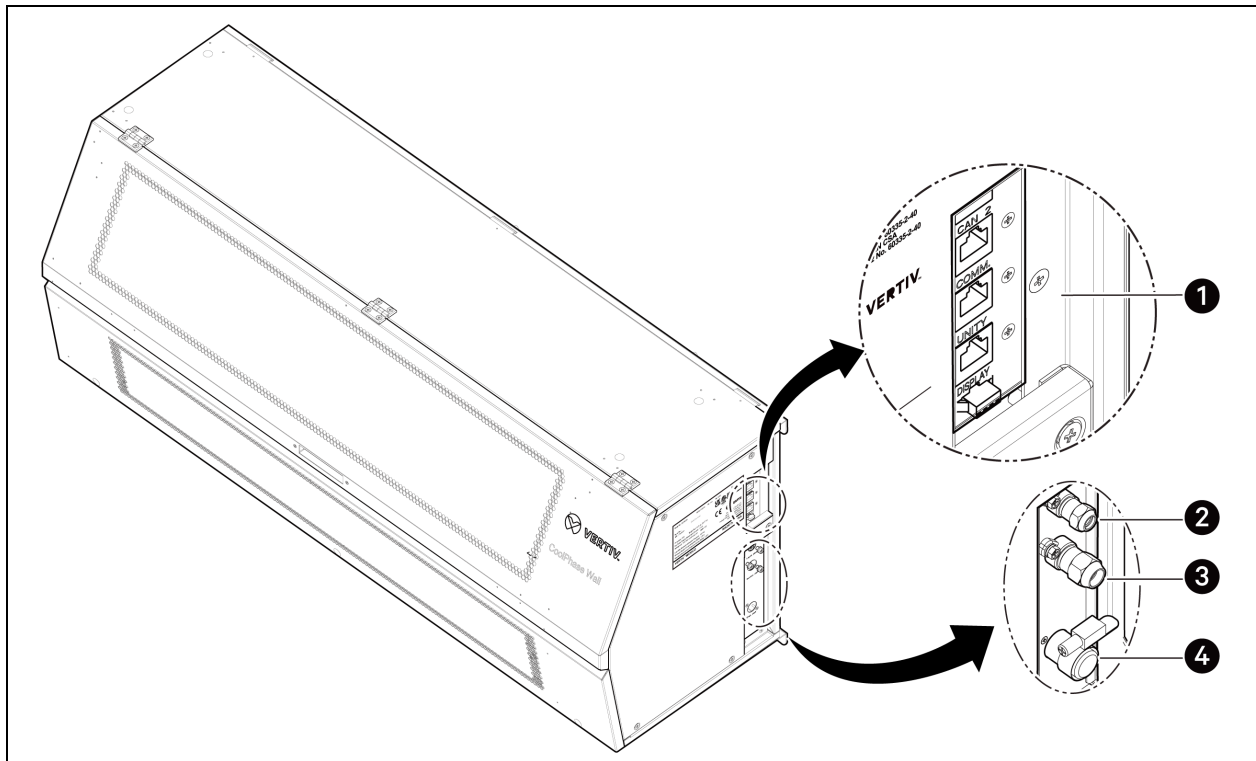

Item	Description	Item	Description
1	Inlets for communications cable	3	Suction connector
2	Liquid connector	4	Drain outlet

Table 5.1 Connector Dimensions per Unit Model

Indoor Unit	Item	Pipe Size	Coupling Size	Torque Value (lb-ft)
WLM030A	Liquid pipe	1/4 in (6.35 mm)	7/16-20 UNF	13.9 – 18
	Suction pipe	1/2 in (12.7 mm)	3/4-16 UNF	39.7-47.7
WLM070A	Liquid pipe	3/8 in (9.52 mm)	5/8-18 UNF	24.5-30.3
	Suction pipe	1/2 in (12.7 mm)	3/4-16 UNF	39.7-47.7
WLM110A	Liquid pipe	3/8 in (9.52 mm)	5/8-18 UNF	24.5-30.3
	Suction pipe	5/8 in (16 mm)	7/8-14 UNF	45.5-59.2

5.2 Indoor Unit and Condensing Unit Connections

5.2.1 Connection Limitations

Vertiv™ CoolPhase Wall systems consist of one condensing unit and one indoor unit. One of the most critical elements of a system is refrigerant piping. **Table 8.2** on page 75 lists pipe-length limits that must be followed in the design of an indoor system. See **Figure 5.3** on the next page and **Figure 5.4** on page 43 for maximum length and elevation of piping.

Figure 5.3 Condensing Unit is Placed Higher than the Indoor Unit

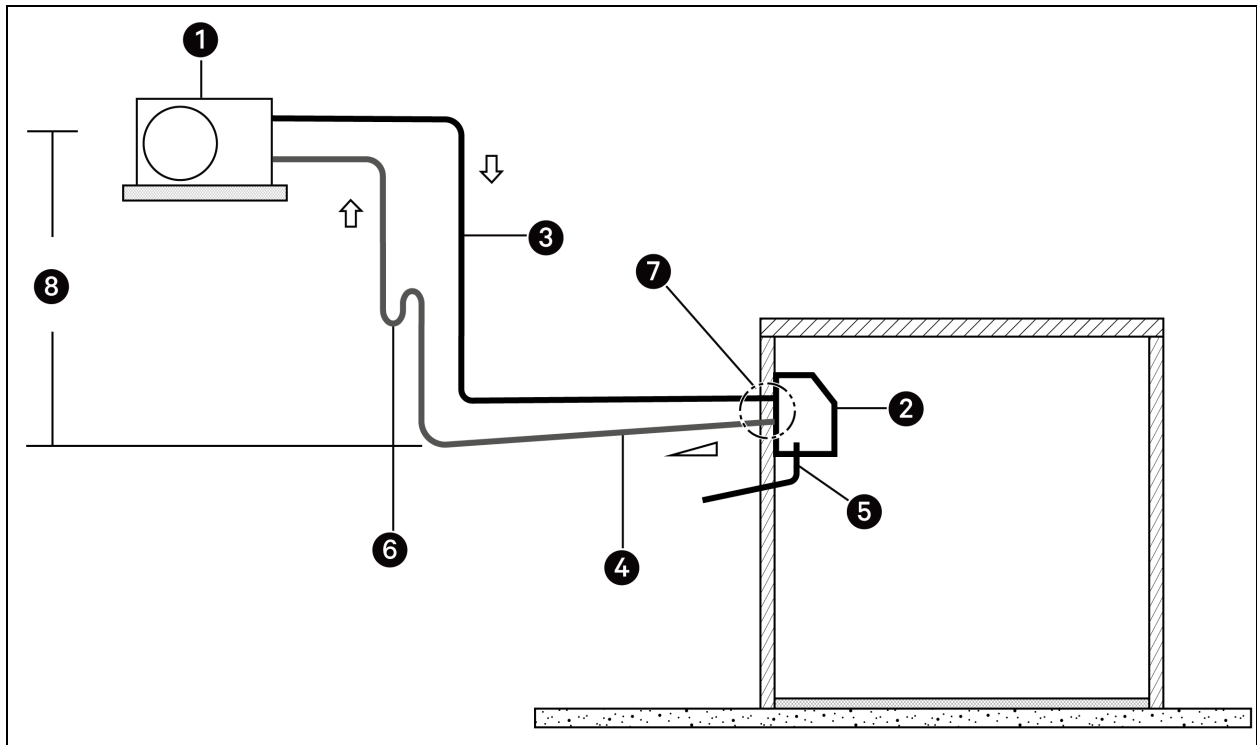

Item	Description	Item	Description
1	Condensing unit	5	Condensate pipe
2	Indoor unit	6	Oil trap (*)
3	Liquid pipe	7	The gap between the pipe and the wall needs to be sealed
4	Suction pipe with 1% downward gradient	8	Max. 98.4 ft (30 m)

NOTE: Install an oil trap every 7.5 m (24.6 ft) of the vertical suction/gas pipe

Figure 5.4 Condensing Unit is Placed Lower than the Evaporator

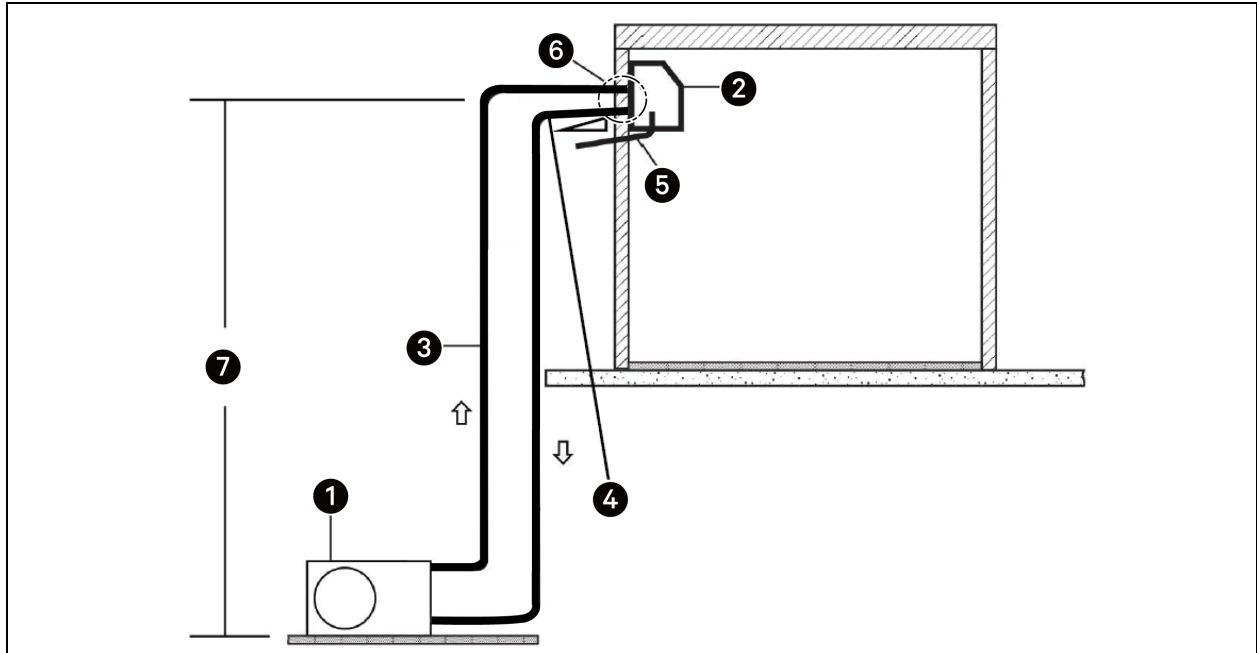

Item	Description	Item	Description
1	Condensing unit	5	Condensate pipe
2	Indoor unit	6	The gap between the pipe and the wall needs to be sealed
3	Liquid pipe	7	Max. 8 m (26.2 ft)
4	Suction pipe with 1% downward gradient		

5.2.2 Length of Connections

The following Table 5.2 below shows the pipe diameters corresponding to different connecting pipe lengths under different unit models.

Table 5.2 Pipe Diameters per Piping Lengths

SKU	Length (ft)	Length (m)	Liquid Line		Suction Line	
			Diameter (in)	Diameter (mm)	Diameter (in)	Diameter (mm)
WLM030A	≤33	≤10	1/4"	6.35	1/2"	12.7
	33-197	10-60	3/8"	9.52	1/2"	12.7
WLM070A	≤33	≤10	3/8"	9.52	1/2"	12.7
	33-115	10-35	3/8"	9.52	5/8"	16
	115-197	35-60	1/2"	12.7	5/8"	16
WLM110A	≤66	≤20	3/8"	9.52	5/8"	16
	66-148	20-45	1/2"	12.7	3/4"	19.05
	148-197	45-60	1/2"	12.7	7/8"	22.23

5.2.3 Liquid Pipe and Suction Pipe Connection

NOTE: The unit is charged with nitrogen at a pressure of 29 psi (2 bar).

Vertiv™ CoolPhase Wall indoor units is a 1-to-1 system. There is a direct piping connection between the condensing unit and the indoor unit. **Figure 5.5** on the facing page illustrates the basic pipe connections between the condensing and indoor unit. Refer to this illustration as you proceed with pipe connection.

Refer to [Length of Connections](#) on the previous page for specific length limitations on indoor and outdoor unit positioning.

Figure 5.5 Piping Installation and Connection Overview

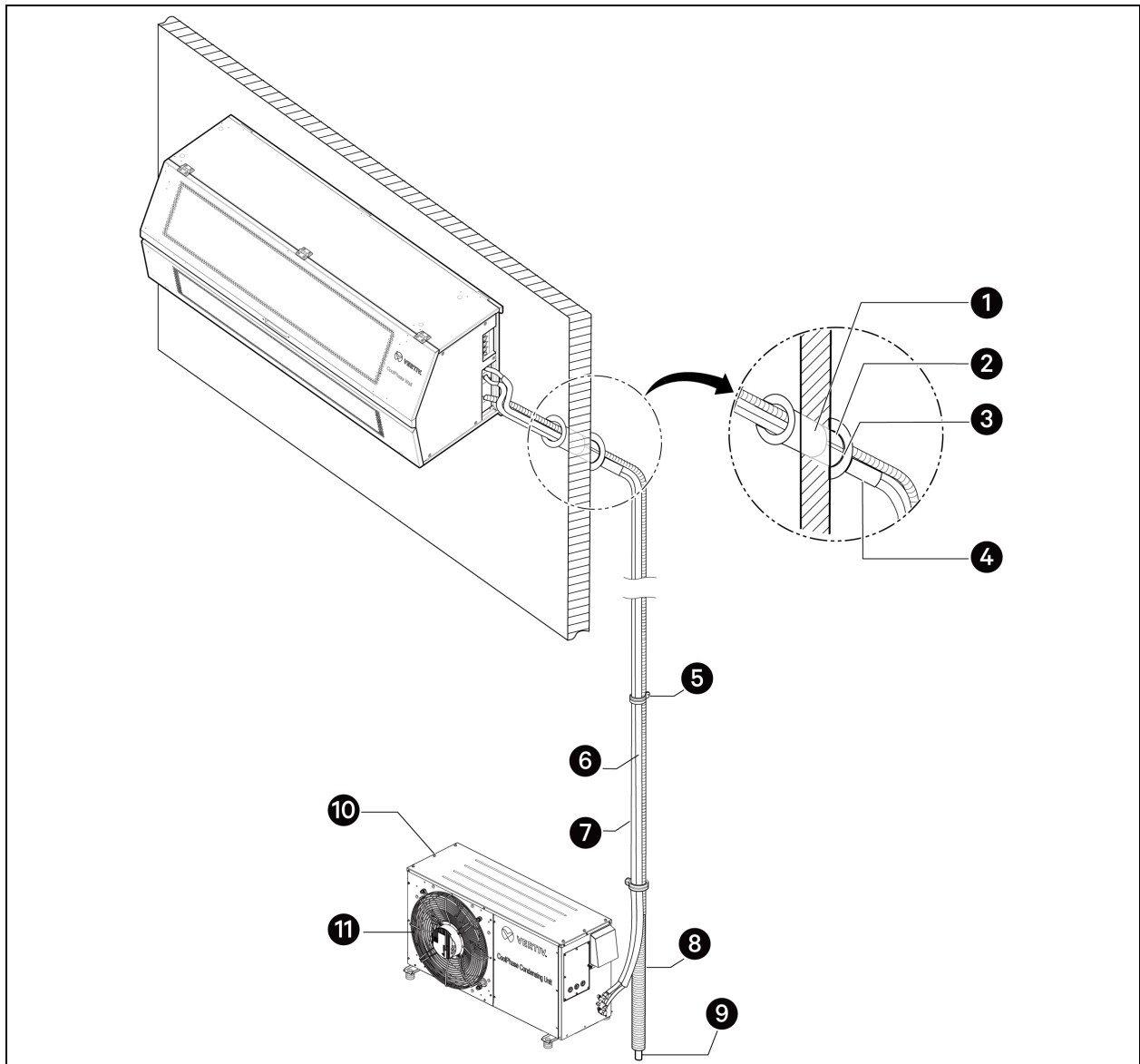

Item	Description	Item	Description
1	Sleeve (not included)	7	Suction line
2	Bushing-sleeve (not included)	8	Additional drainpipe
3	Duct seal putty (not included)	9	Drain hose
4	Bend the pipe as closely on the wall as possible but be careful that it doesn't break.	10	Air inlet
5	Pipe clip	11	Air outlet
6	Liquid line		



WARNING! The operation of opening the valves and cutting the pipes at the bottom of the unit must be conducted as final operations.

Note the following while connecting gas pipe and liquid pipe:

- Connect the condensing unit and indoor units using copper pipes.
- Use as short refrigeration pipelines as possible to minimize the total charge of refrigerant and the pressure drops.
- Reduce the number of bends to a minimum. The bend must be of a large radius, at least equal to pipe diameter. If not using preformed curves, bend the pipes as follows:
 - Soft copper: by hand or bending device.
 - Hard copper: use preformed curves. Do not overheat the pipes when brazing to minimize oxidation.
- Lay the horizontal gas pipes with 1% downward gradient in the direction of the refrigerant flow.
- Maintain a minimum distance of 0.8 in (20 mm) between the gas and liquid pipelines. If this is not possible, insulate both the lines.
- Insulate the piping to avoid damage to cable if the pipes are put next to electrical cables.
- Support both horizontal and vertical pipes with vibration damping clamps (including rubber gaskets). It is recommended to put pipe clamps or clips every 4.9 ft to 6.6 ft (1.5 m to 2 m).
- Install an oil trap every 24.6 ft (7.5 m) of the vertical suction line.

NOTE: Equivalent pipe length = Length of straight pipe + Equivalent length of bend.

Table 5.3 Equivalent Length for Bends and Valves

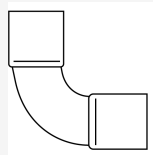
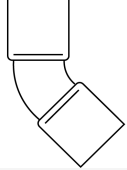
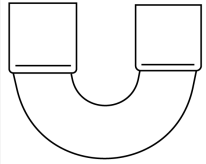
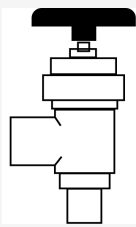
Liquid pipe outer diameter in (mm)	Equivalent length ft (m)			
	90° bend 	45° bend 	180° U bend 	90° shut off valve 
1/4 (6.35)	1.28 (0.39)	0.66 (0.20)	1.94 (0.59)	4.92 (1.50)
3/8 (9.52)	1.44 (0.44)	0.72 (0.22)	2.13 (0.65)	5.91 (1.80)
1/2 (12.7)	1.64 (0.50)	0.82 (0.25)	2.46 (0.75)	6.90 (2.10)
5/8 (16)	1.80 (0.55)	0.88 (0.27)	2.79 (0.85)	7.87 (2.40)

Installing Pipelines

To connect the piping, please follow the indications below:

1. Remove the suction/liquid connector caps.
2. Align the center of the refrigerant pipe and the corresponding connection, as shown below.
3. Refer to **Figure 5.7** on the next page for the correct liquid and suction pipe attachment to the indoor unit.
4. Before assembling, put a couple of drops of refrigerant oil on the flare's opening rim to prevent contaminants from introducing, and tighten the flare nut by hand.
5. Finish tightening the flare nut with a torque wrench until the wrench clicks; refer to **Figure 5.7** on the next page for correct connection points.
6. Use as short refrigeration pipelines as possible to minimize the refrigerant's total charge and pressure drops.
7. Reduce the number of bends to a minimum. The bend must have a large radius, at least equal to the pipe diameter.
8. Insulate all piping to prevent heat loss and protect nearby cables from heat damage.
9. If brazing is required, use a brazing alloy with a melting point of at least 1350°F (732°C), e.g., Sil-Fos. Do not use soft solders such as 50/50, 95/5, or Stay Brite.

Figure 5.6 Align the Center of the Piping Connection

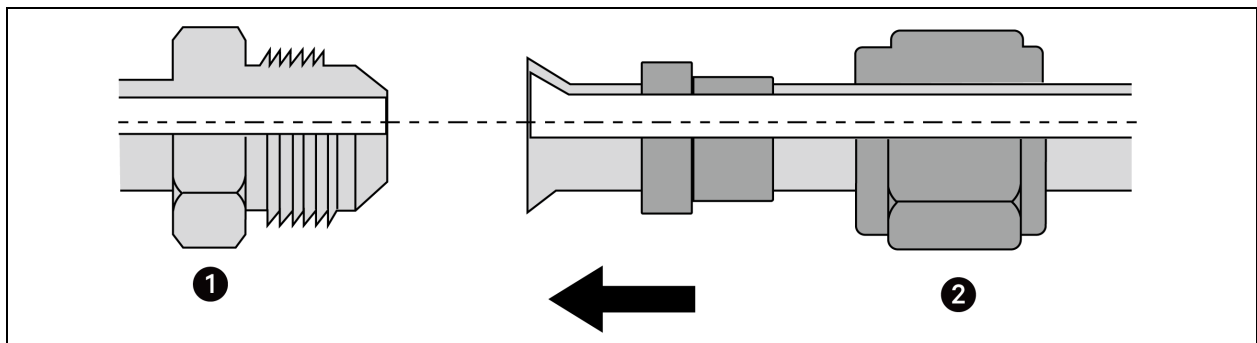

Item	Description
1	Indoor Unit flare fitting
2	Flare nut

Figure 5.7 Correct Piping Attachment for Indoor Unit

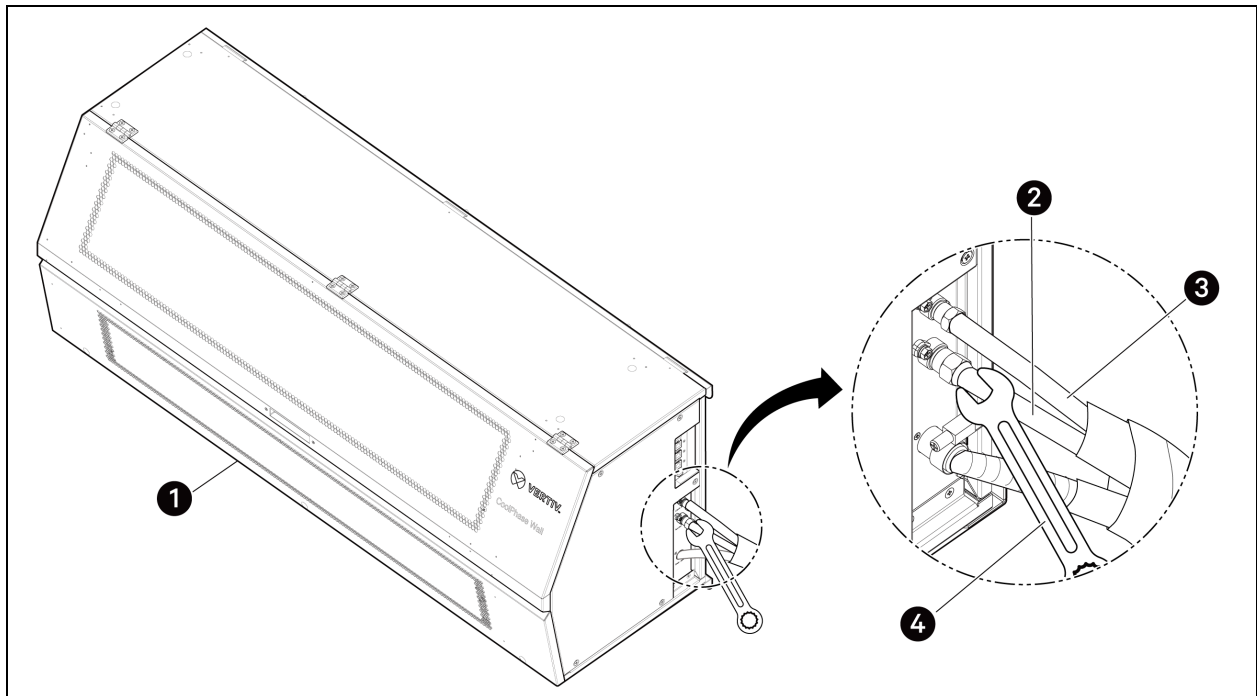

Item	Description	Item	Description
1	Indoor Unit	3	Liquid line
2	Suction line	4	Torque wrench

NOTE: Use Nitrogen gas during brazing to prevent interior piping oxidation, fouling of the refrigerant system, and plugging the system filter dryer.

NOTE: When tightening the flare nut with a torque wrench, ensure the direction for tightening follows the arrow on the wrench.

5.2.4 Piping Insulation

To prevent heat loss/heat gain through the refrigerant piping, all refrigerant piping, including liquid lines and suction lines, must be insulated separately. Insulation must be a minimum 1/2-in. thick, and the thickness may need to be increased based on ambient conditions and local codes.

NOTE: Do not insulate gas and liquid pipes together as this can result in pipe leakage and malfunction due to extreme temperature fluctuations. Be sure to fully insulate the piping connections.

Figure 5.8 Typical Pipe-insulation Arrangement

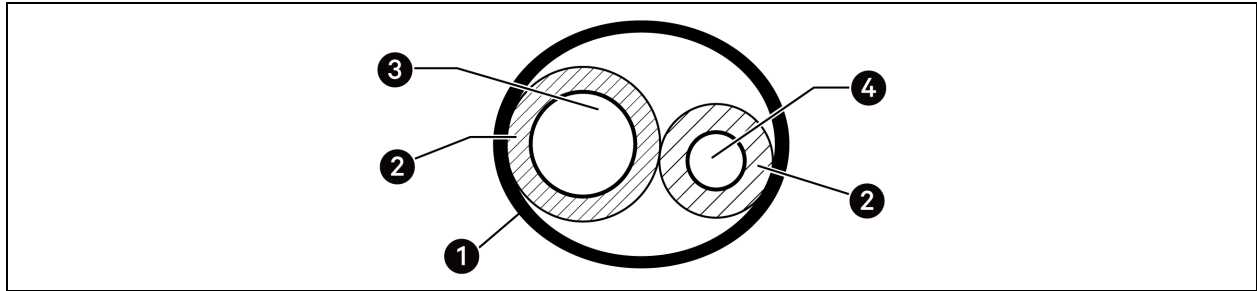

Item	Description	Item	Description
1	Pipe sleeve (optional, not included)	3	Suction line
2	Insulation material	4	Liquid line

Figure 5.9 Typical Butt-joint Insulation at Indoor Unit

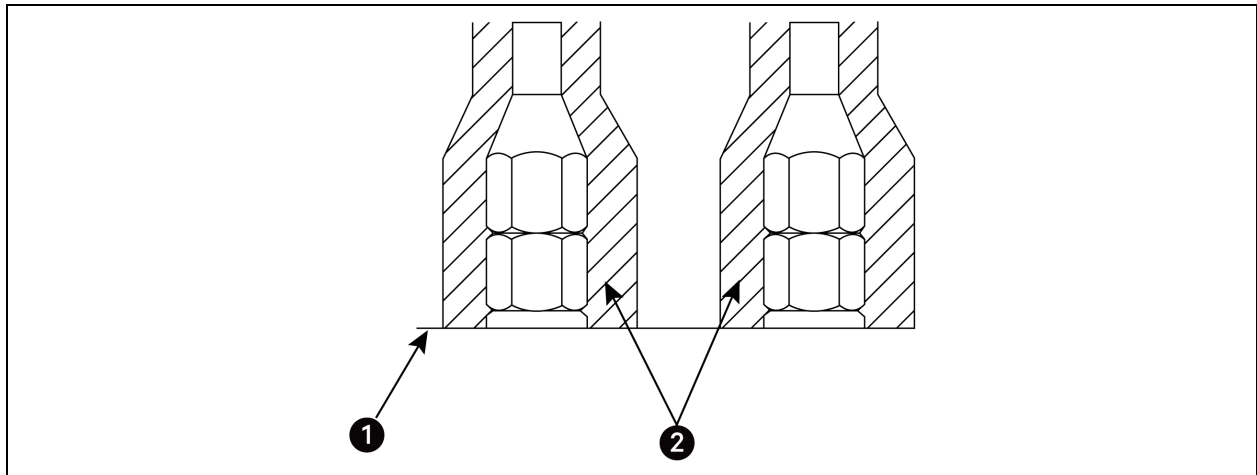

Item	Description
1	Surface of indoor-unit casing
2	Field-supplied pipe insulation

Figure 5.10 Typical Refrigerant Flare-fitting Insulation

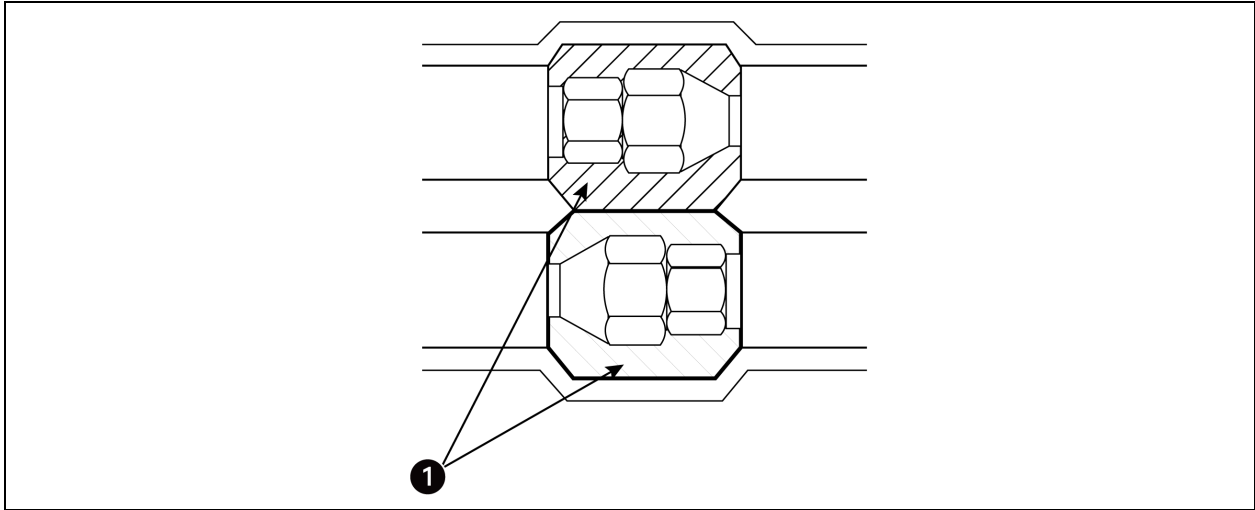

Item	Description
1	Field-supplied insulation

5.2.5 Drainpipe Connection

Drain hose is routed from the indoor unit, through the structure (wall) to the outdoors. The hose should slope at an angle where it is higher at the indoor unit and lower at the outdoor area, letting gravity push condensation down and out. **Figure 5.11** below, shows the proper drainage slope. **Figure 5.12** on the facing page shows incorrect methods of routing the drain hose, which cause leakage at the indoor unit.

Figure 5.11 Correct Slope Angle for Drain Hose

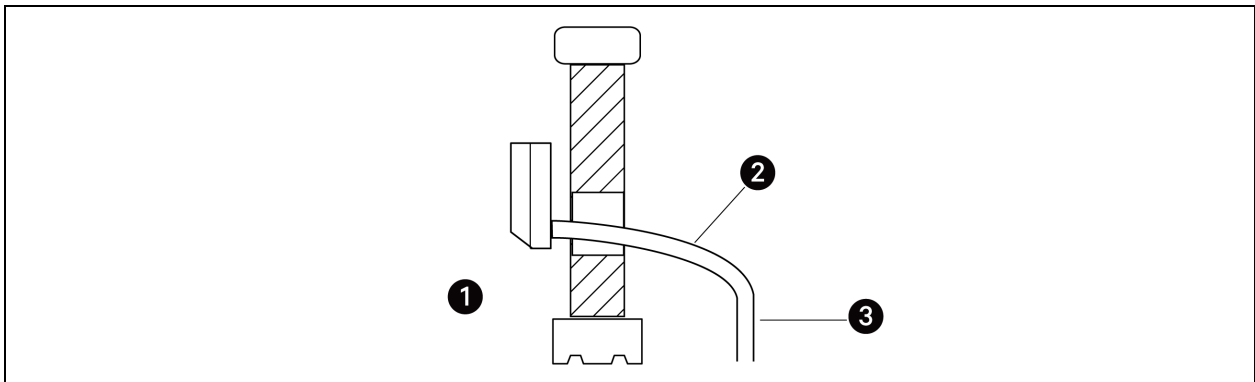

Item	Description	Item	Description
1	Indoor unit	3	Piping
2	Downward slope to outdoors for proper drainage		

Figure 5.12 Incorrect Methods of Routing Drain Hose

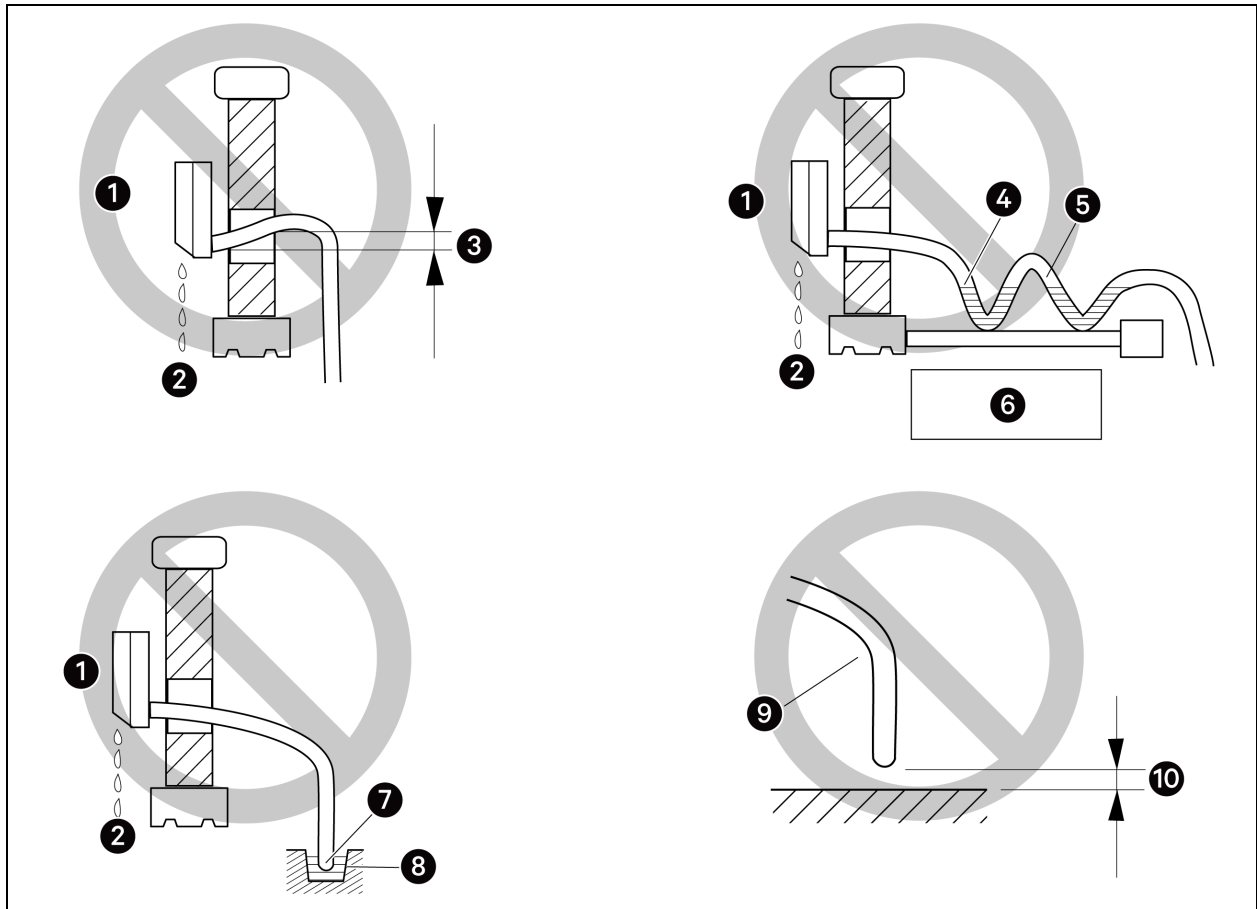

Item	Description	Item	Description
1	Indoor unit	6	Waving
2	Water leakage	7	Tip of drain hose dipped in water
3	Upward slope to outdoor can cause indoor leaks.	8	Open drain
4	Accumulated drain water	9	Drain hose
5	Air	10	Less than 2-in. gap from ground.

5.2.6 Condensate Pump Kit Connection

Key Features:

- Power: 208/230V, 1ph, 50/60Hz
- Max recommend head: 16.4 ft (5m), only the drainpipe diameter is 6 mm OD

Figure 5.13 Condensate Pump Reservoir

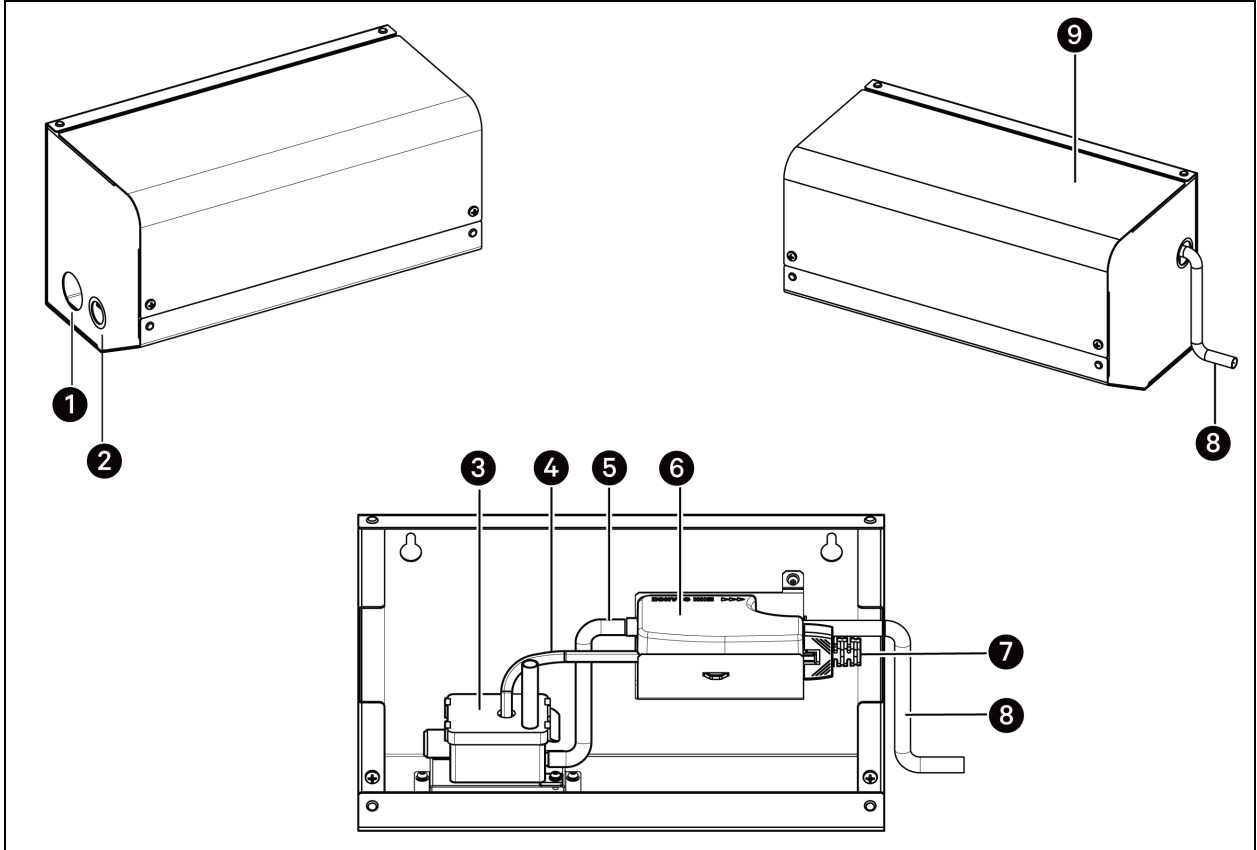

Item	Description	Item	Description
1	Piping Inlet	6	Assembled pump
2	Cable outlet	7	Power cable (length: 1.5 m)
3	Assembled reservoir	8	Drain pipe
4	Communication cable	9	Metal pump case
5	Connection pipe		

NOTE: The optional, field-installed condensate pump will be located outside the evaporator unit.

Figure 5.14 Mounted Condensate Pump Kit Suggested Location

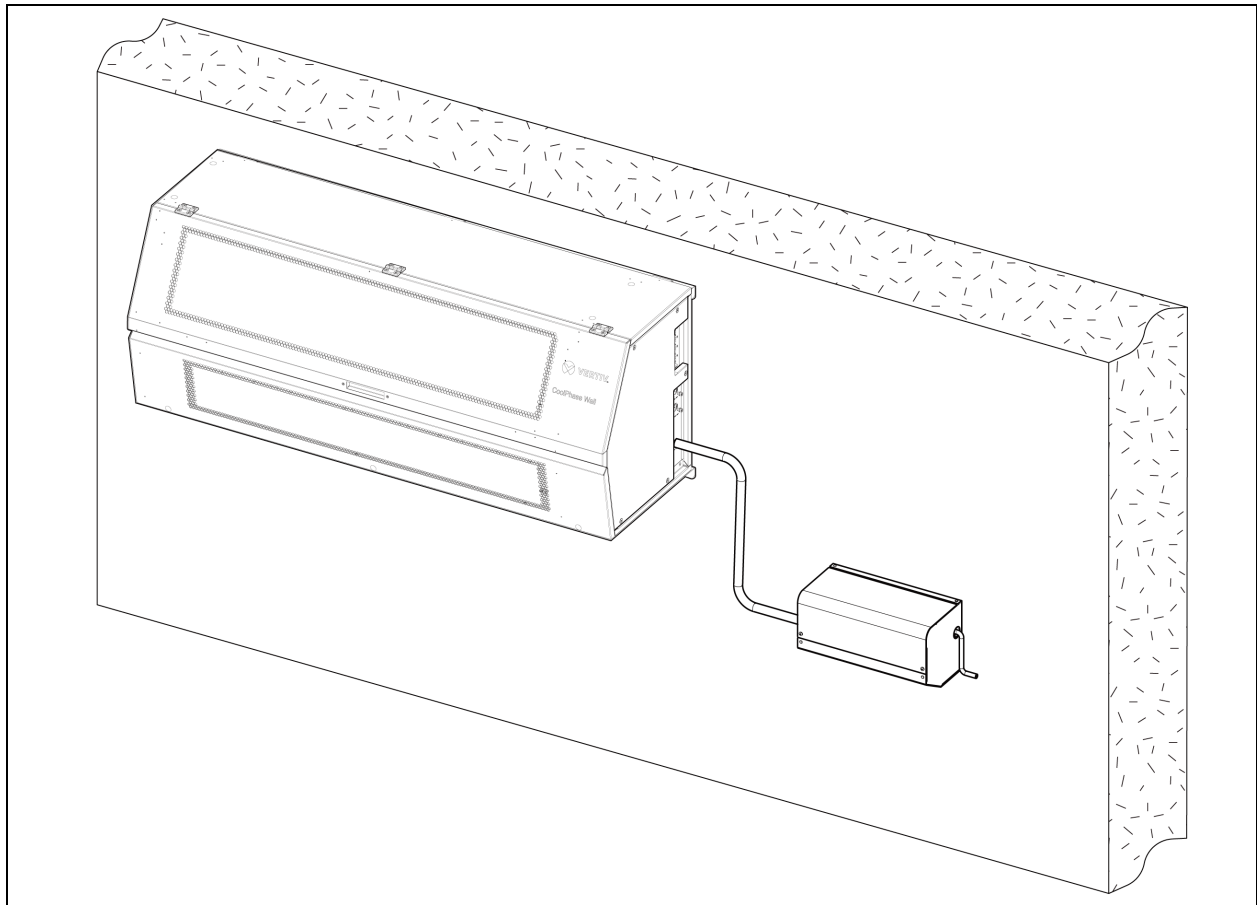

NOTE: The pump should always be put lower than the indoor unit.

For more information on how to install the Condensate Pump, refer to the [Condensate Pump Kit Quick Installation Guide SL-71205](#).

5.2.7 Piping Leak Test



WARNING! Risk of using combustible gases. It can cause explosion and fire, resulting in building and equipment damage, significant injury, or death. Do not use flammable gases, including oxygen, for leak detection. Use only inert gas (nitrogen) when checking plumbing leaks, cleaning, repairing pipes, etc.

Perform the leak test by pressurizing nitrogen gas to 145 psi (10 bar) on both the liquid and gas pipes. Test with the piping service valves open. The system passes the test if the pressure does not drop for 24 hours. If the pressure drops, there is a nitrogen leak in the system. Find the leak, repair it, and test again.

Connecting the pressure gauge

NOTE: When pressurizing the refrigerant system, the top of the cylinder must be higher than the bottom to prevent nitrogen from entering a liquid state. Also, ensure the cylinder is used in a vertical standing position.

NOTE: Connect the manifold valve (which includes the pressure gages) and the dry-nitrogen gas cylinder to the services valves using a charge hose, as shown in **Figure 5.16 on the facing page.**

NOTE: Pressurize the system to a maximum of 145 psi (10 bar) with dry-nitrogen gas and close the cylinder valve when the gauge reaches 145 psi (10 bar).

Charge the dry-nitrogen gas and leaking test:

1. Remove the caps from the suction valve and liquid valve of condensing unit.
2. Open the 2-way valve by turning the valve stem counterclockwise approximately 90 degrees, wait 2 to 3 seconds.
3. Open the manifold valve and charge the dry-nitrogen gas. Refer to **Figure 5.16** on the facing page
4. While running nitrogen pressure, apply soapy water or liquid, neutral detergent on the indoor or Condensing Unit connections using a soft brush, and observe the connections for any leaks. Bubbles at connection points or joints indicate a leak.
5. Note any leaks along the liquid and suction lines.
6. Disengage the nitrogen pressure by loosening the charge hose at the cylinder. Refer to **Figure 5.16** on the facing page
7. When pressure returns to normal, disconnect the charge hose from the cylinder.
8. Repair all connections and piping where there are leaks.
9. When repairs are complete, repeat the leak test using nitrogen pressure and check for further leaks.
10. Once the piping system is leak-free, proceed to Evacuation below.

Figure 5.15 Removing Service-valve Caps from the Condensing Unit for Purging

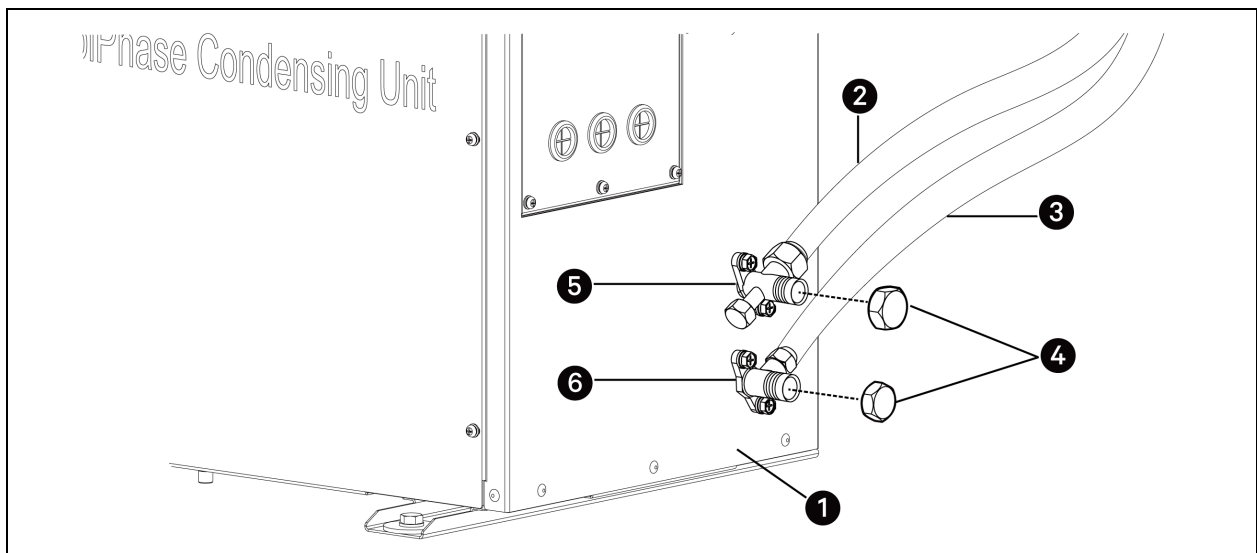

Item	Description	Item	Description
1	Condensing unit	4	Valve caps
2	Suction line	5	Suction valve
3	Liquid line	6	Liquid valve

Figure 5.16 Leak Test Setup Diagram

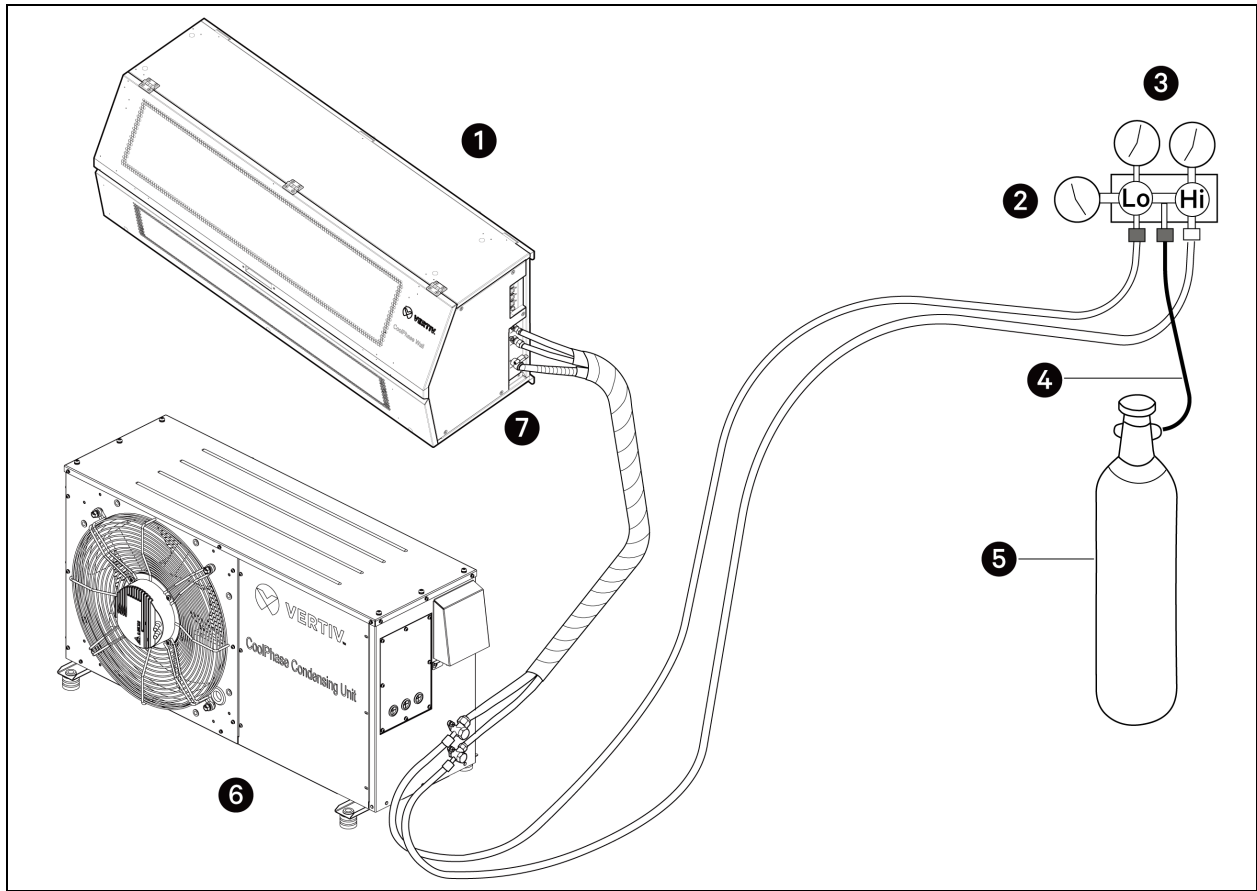

Item	Description	Item	Description
1	Indoor unit	5	Nitrogen-gas tank (upright position)
2	Pressure gauge	6	Condensing Unit
3	Manifold valve	7	Piping bundle
4	Charge hose		

5.2.8 Evacuating the Unit

Evacuation is performed after all piping is connected between the indoor and the Condensing Unit. This step is necessary to ensure that no air and moisture are left in the piping. Air and moisture that is left in the piping can lead to undesirable results and can cause damage to the working unit. Going through a complete air-purging cycle ensures the lines are cleared out. Note that you may need to repeat this process for any air or moisture remaining in the piping. After air purging and evacuating the lines, do a leak test for all piping and tubing.

Insufficient or incorrectly performed air purging may lead to the following:

- Pressure in the system can rise.
- Operating current can rise.
- Cooling or heating efficiency falls.
- Moisture in the refrigerant circuit may freeze and block capillary tubing.
- Water can lead to corrosion of parts in the system.

Evacuate the System

1. Connect the manifold with the service valve and the vacuum pump. Refer to **Figure 5.17** on the facing page.
2. Confirm that the "**Lo**" knob of the manifold valve is open.
3. Confirm that the "**Hi**" knob the manifold valve is open.
4. Confirm that the suction valve and liquid valve is open.
5. Run the vacuum pump until the system is evacuated down to 40 pa (300 microns) and continue running the pump for 15 minutes.
6. When appropriate time has elapsed, turn off the pump and leave the connections secured on the service valves for 5 minutes.
7. If the system fails to hold 65 pa (500 microns) or more, check all connections for a tight fit and repeat the evacuation steps.

NOTE: The duration of running the vacuum pump will vary according to pipe length and pump capacity

Figure 5.17 Evacuation Diagram

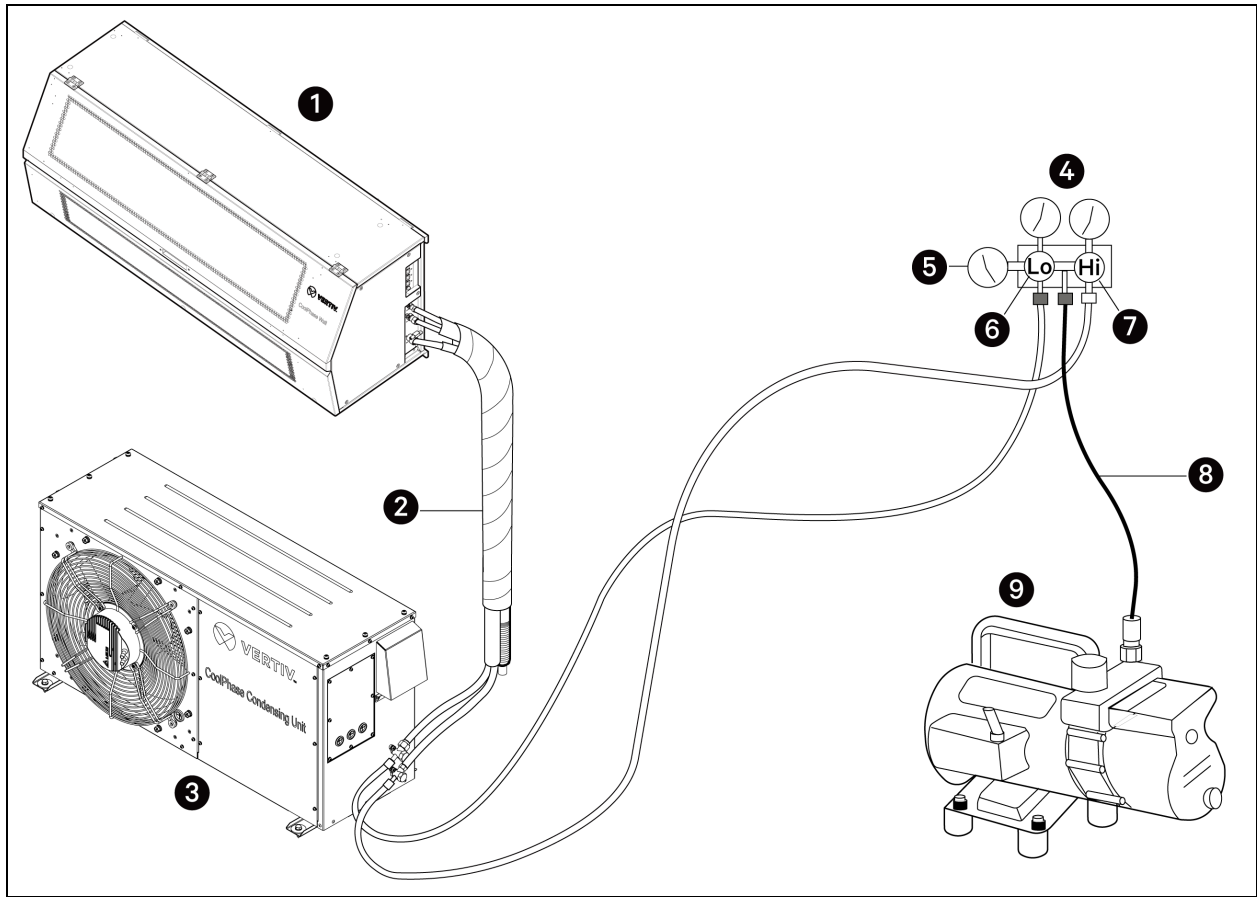

Item	Description	Item	Description
1	Indoor unit	6	Lo knob
2	Piping bundle	7	Hi knob
3	Condensing unit	8	Charge hose
4	Manifold valve	9	Vacuum pump
5	Pressure gauge		

This page intentionally left blank

6 Electrical Connections



WARNING! Arc flash and electric shock hazard. Open all local and remote electric power-supply disconnect switches, verify with a voltmeter that power is Off and wear appropriate, OSHA-approved personal protective equipment (PPE) per NFPA 70E before working within the electric control enclosure. Failure to comply can cause serious injury or death. Customer must provide earth ground to unit, per NEC, CEC, and local codes, as applicable. Before proceeding with installation, read all instructions, verify that all the parts are included and check the nameplate to ensure the voltage matches available utility power. The Vertiv™ Liebert® iCOM™ Edge Controller does not isolate power from the unit, even in the “Unit Off” mode. Some internal components require and receive power even during the “Unit Off” mode of the controller. The only way to ensure that there is NO voltage inside the unit is to install and open a remote disconnect switch. Refer to unit electrical schematic. Follow all local codes.



WARNING! Risk of electric shock. Can cause equipment damage, injury, or death. Open all local and remote electric power supply disconnect switches and verify with a voltmeter that power is off before working within any electric connection enclosures. Service and maintenance work must be performed only by properly trained and qualified personnel and in accordance with applicable regulations and manufacturers’ specifications. Opening or removing the covers to any equipment may expose personnel to lethal voltages within the unit even when it is apparently not operating and the input wiring is disconnected from the electrical source.



WARNING! The equipment shall be installed in accordance with national wiring regulations.



WARNING! A means for disconnection from the supply mains having a contact separation in all poles that provide full disconnection under overvoltage category III conditions must be incorporated in the fixed wiring.

Safety Instruction

Check that cabling will not be subject to wear, corrosion, excessive pressure, vibration, sharp edges, or any other adverse environmental effects. The check shall also consider the effects of aging or continual vibration from sources such as compressors or fans.

Before proceeding with the electrical connections, ensure that:

- The unit has been safely and firmly fixed to the wall.
- All electrical components are in good condition.
- All terminal screws are tight.
- The supply voltage and frequency are as indicated on the unit.

Figure 6.1 Configuration of the E-box

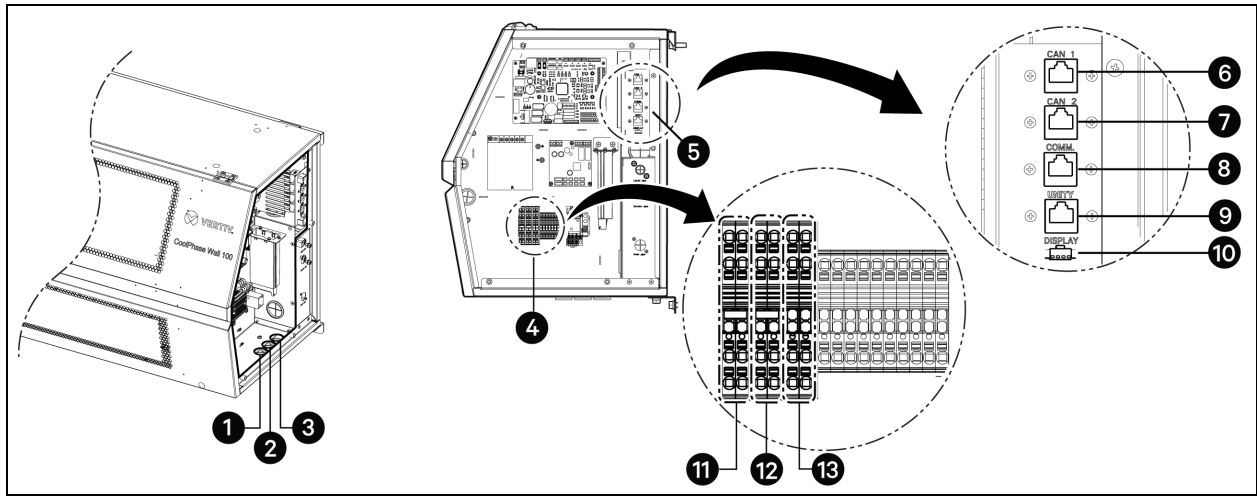

Item	Description	Item	Description
1	Power cable hole of indoor unit	8	Communication cable port
2	Cable hole of condensate pump kit	9	Unity card port
3	Cable hole of Function cord	10	LCD display terminal
4	Terminal block	11	L1
5	Communication signal port	12	L2/N
6	Teamwork control 1 port	13	PE
7	Teamwork control 2 port		

6.1 Connecting Power Supply Cable

The power supply is 208/230 V 1 Ph 50/60 Hz for the unit. The size of power cable must support the full load current. Do not fit the supply cable in the raceways inside the electrical panel. Multipolar cables with sheath (IEC60332-1 / UL1685 VW-1 CABLE) are recommended.

Table 6.1 Unit Electrical Data

Model	MCA (A)	MOP (A)	FLA (A)
WLM030A	3	15	2
WLM070A	4	15	3
WLM110A	5	15	5

Table 6.2 Total Electrical Data for Condensing Unit and Compatible Indoor Unit

Compatible Indoor Unit	Condensing Unit Model	MCA (A)	MOP (A)	FLA (A)
WLM030A	CUD030-E000A CUL030-E000A	24	35	19
WLM070A	CUD070-E000A CUL070-E000A	32	50	26
WLM110A	CUD111-E000A CUL111-E000A	30	45	26
WLM110A	CUD115-E000A CUL115-E000A	23	35	20

NOTE: The FLA, MOP, and MCA values in the **Table 6.2** above, are the total values for the condensing unit and the indoor unit. These values apply when the indoor unit receives power from the condensing unit.

To connect the power supply cables:

1. The E-box 1 is located in the right side of the unit. Remove the E-box cover from the electrical box 1 by removing six (6) M5 - 0.7 x 25 mm flat head screws.
2. Route the power supply cables into the unit by passing them through the grommet holes located at the bottom of the unit and connect the cables to the L1, L2/N, and PE power supply terminals blocks.

Figure 6.2 Removing the E-Box Cover

Figure 6.3 Power Cable Connection



Item	Description	Item	Description
1	Terminal Block (same for all models)	3	Power supply L2 or N
2	Power supply L1	4	Power supply PE

The Vertiv™ CoolPhase Wall Unit can either be powered by a Vertiv™ CoolPhase Condensing Unit or operate independently.

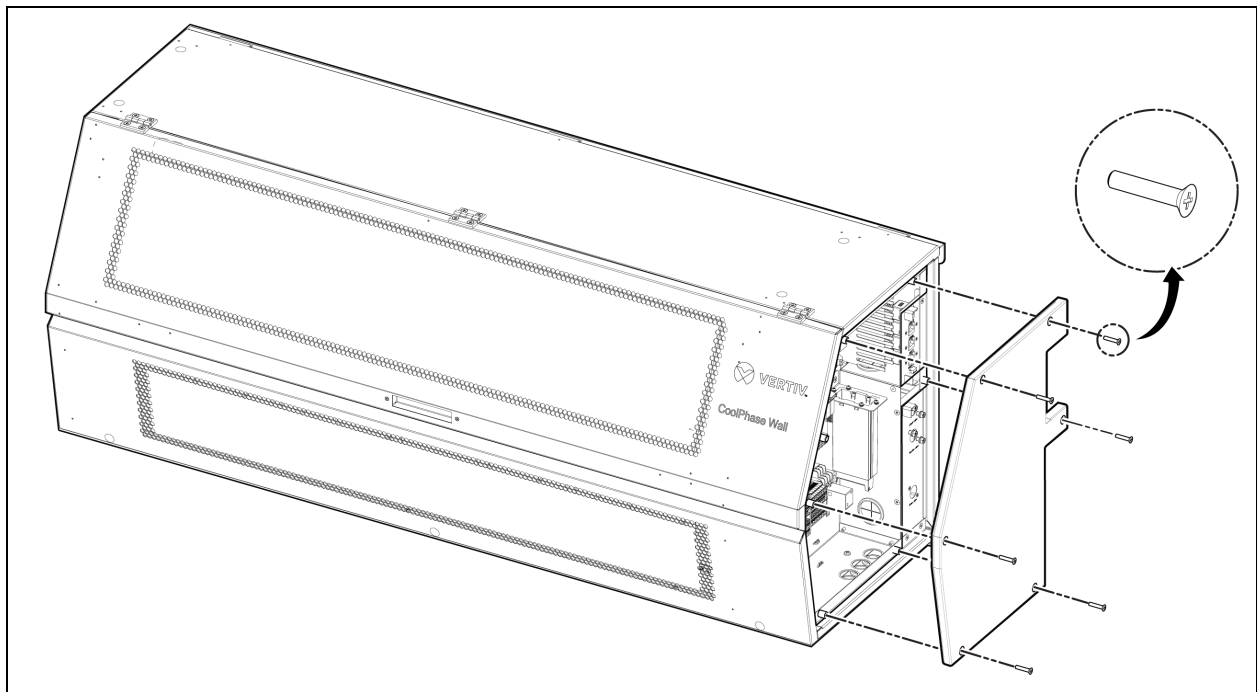
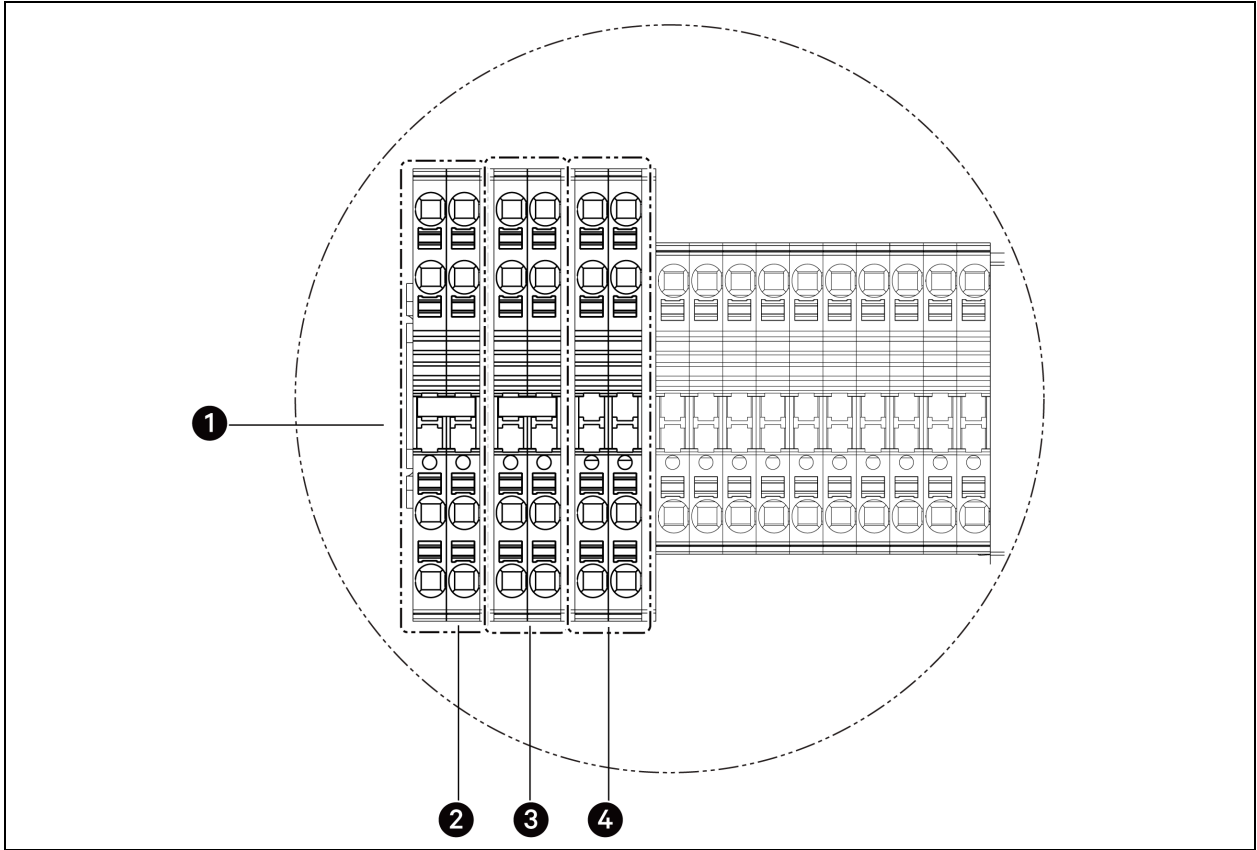
- When powered independently: Connect L1, L2/N, and PE directly from the distribution box.
- When powered by the Vertiv CoolPhase Condensing Unit: The power connection method is shown in the **Figure 6.4** on the facing page. To avoid wiring errors and potential equipment damage, all connections must be made in the exact order shown. Each wire must be connected individually and carefully.

Figure 6.4 Power Connection When the Indoor Unit Receives Power from the Condensing Unit

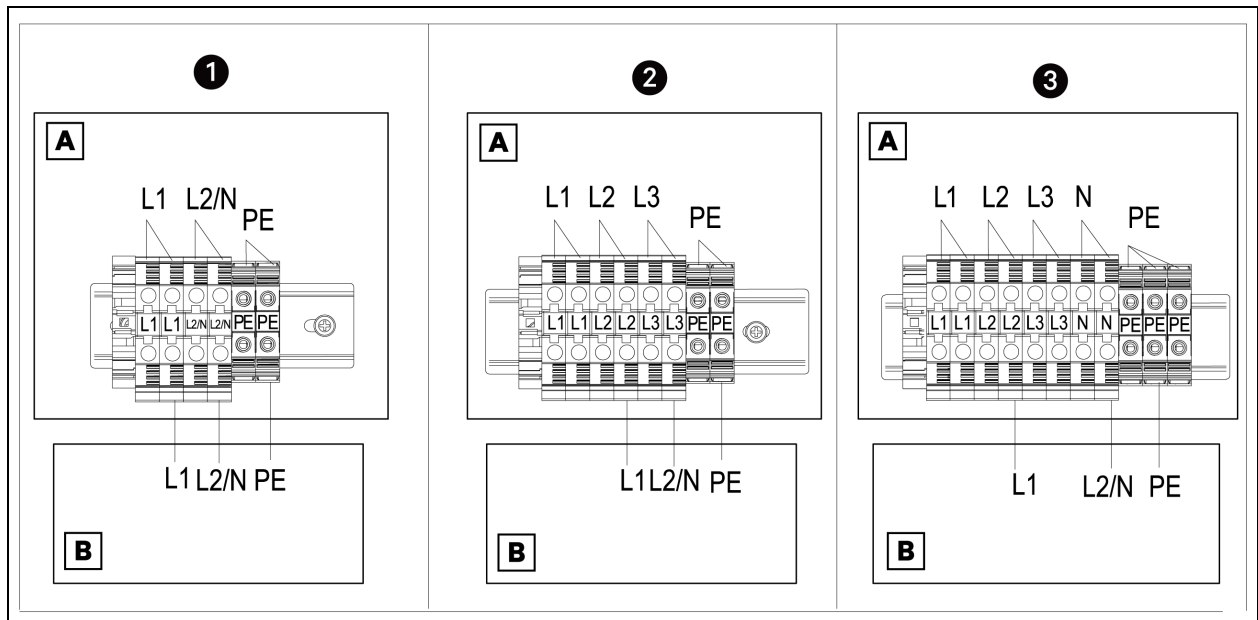

Item	Description	Item	Description
A	Condensing unit	2	Combination: WLM110A+CUD111-E000A, CUL111-E000A
B	Vertiv™ CoolPhase Wall unit	3	Combination: WLM110A+CUD115-E000A, CUL115-E000A
1	Combination: WLM030A+CUD030-E000A, CUL030-E000A WLM070A+CUD070-E000A, CUL070-E000A		

NOTE: The CU*111 model is intended for use in NAM, where the power supply may not include a neutral wire and the line-to-line voltage is 208V or 230V.

NOTE: The CU*115 model is intended for use in EMEA, where the power supply may include a neutral wire and the line-to-line voltage is 400V.

NOTE: Before installation, always verify that you have the correct model and ensure the wiring sequence for both the indoor and outdoor units is accurate. Improper wiring may result in serious equipment damage or pose a significant fire hazard.

6.2 Connecting Communications Cables

6.2.1 General Arrangement

IMPORTANT! The communication line shielding layer must be grounded. Do not run cabling for multiple units in the same conduit. Each unit cabling must be run in a separate conduit.

NOTE: The communication cable must be shielded. The shielding (ground wire) should be connected to the PE terminal.

NOTE: The size of the cable should be 24AWG, and the length should be shorter than 295.27 ft (90 m).

NOTE: Use standard Ethernet cable (Cat 5e) for communication.

- Insulation materials as required by local code.
- Rated for continuous exposure of temperatures up to 140°F (60°C).
- Firmly attach the cable. Provide slack but secure in a way to prevent external forces from being imparted on the terminal block.
- Terminate the cable shield to a grounded surface at the outdoor unit only.
- Always verify that the communication cable is connected to a communications terminal on the unit. Never apply line-voltage power to the communication-cable connection. If contact is made, PCBs may be damaged.
- The shield of the communication cable connecting the outdoor unit to the indoor unit should be grounded only to the Vertiv™ CoolPhase Condensing Unit frame.
- Tie the shield of each cable segment together using a wire nut at each indoor unit. Maintain polarity through the communication network.

NOTE: Take anti-static measures when connecting communications cables.

Figure 6.5 Communications Ports

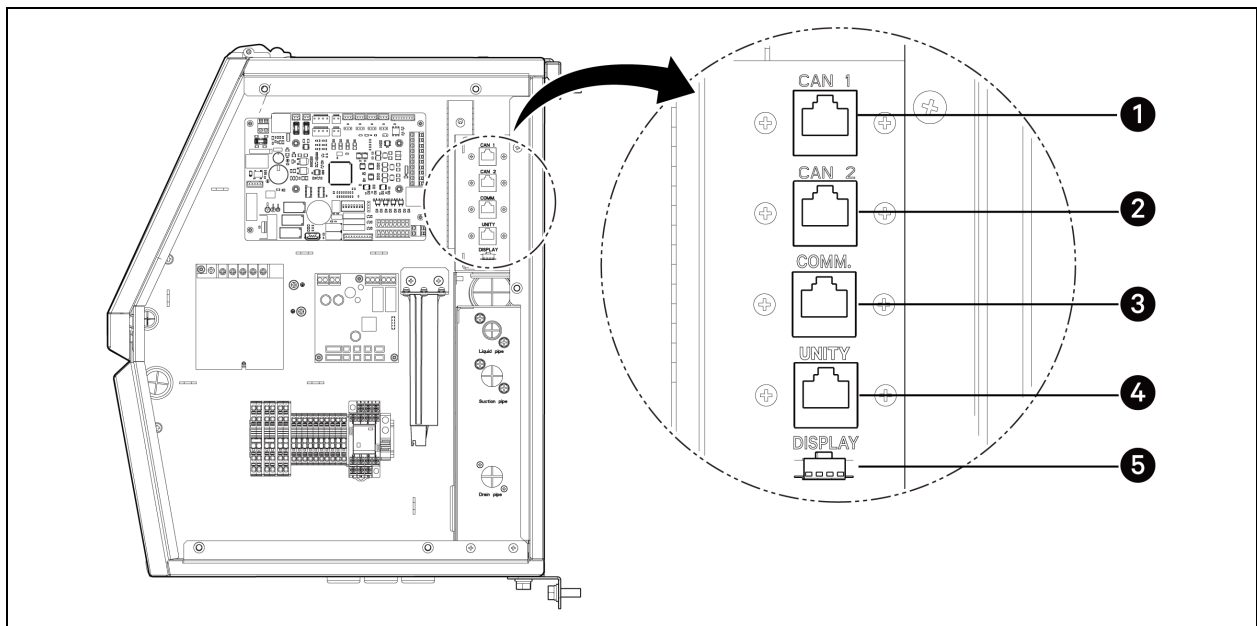

Item	Description	Item	Description
1	Teamwork control 1 port	4	Unity card port
2	Teamwork control 2 port	5	LCD display terminal
3	Communication cable port		

6.2.2 Connecting Communications Cable between Indoor Unit and Condensing Unit

The communications cable is not provided with the unit.

The connection between the indoor unit and condensing unit is made through an ethernet cable going from the COMM port to Vertiv™ CoolPhase Condensing Unit COMM port located in the connection panel.

NOTE: Use standard ethernet cables (Cat 5e) as communication cables. The size of the cable should be larger than 24AWG.

6.2.3 Connecting the Monitor Device to Unity Card

The monitor device is not provided with the unit. To connect the monitor device, connect it to the Ethernet port on the unity card.

6.2.4 Connecting for Teamwork

Connect the CAN port of one indoor unit to the CAN port of another indoor unit using a CAN network cable. Set the CAN ID of each unit on the DIP SW3. The DIP SW3 is located on the Vertiv™ Liebert® iCOM™ Edge Controller.

To access the DIP SW3:

1. Remove the cover plate from the electrical box by removing six (6) M4-0.7x8mm flat head screws,
2. If necessary, remove the four (4) M4 flat head screws of the power detector board, then remove the Power Detector board on the Vertiv Liebert iCOM Edge Controller.
3. If the power detector board is removed, remember to fix it after connecting the teamwork.

Figure 6.6 Location of DIP SW3

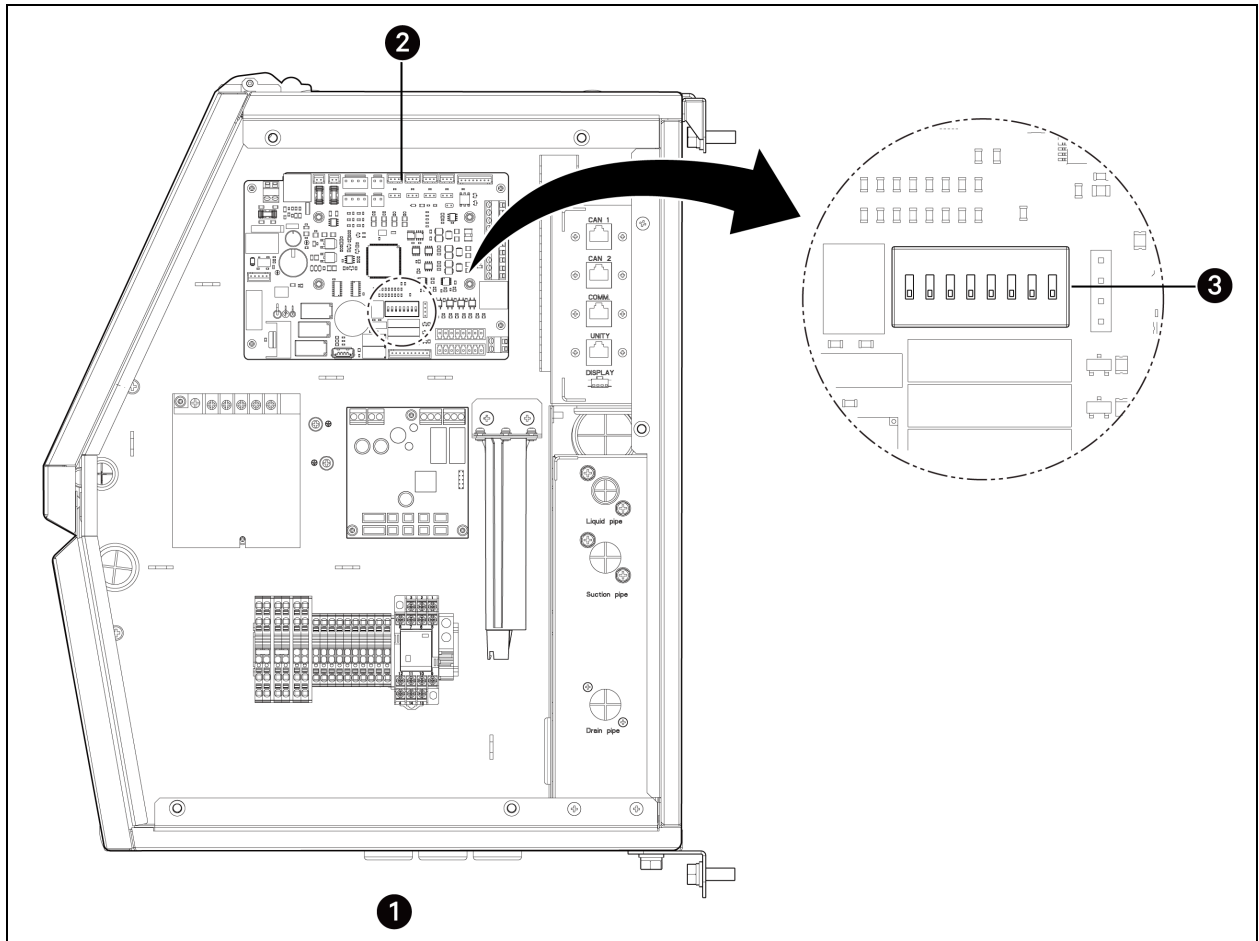

Item	Description	Item	Description
1	Electrical box (E-box)	3	DIP SW3
2	Vertiv™ Liebert® iCOM™ Edge Controller		

Table 6.3 Address Settings of CAN ID

CAN ID	SW3-1	SW3-2	SW3-3	SW3-4	SW3-5	SW3-6	SW3-7	SW3-8	Note
0	ON	ON	ON	ON	ON	ON	ON	ON	Master Unit
1	OFF	ON	ON	ON	ON	ON	ON	ON	Slave Unit 1
2	ON	OFF	ON	ON	ON	ON	ON	ON	Slave Unit 2
3	OFF	OFF	ON	ON	ON	ON	ON	ON	Slave Unit 3
4	ON	ON	OFF	ON	ON	ON	ON	ON	Slave Unit 4
5	OFF	ON	OFF	ON	ON	ON	ON	ON	Slave Unit 5
6	ON	OFF	OFF	ON	ON	ON	ON	ON	Slave Unit 6
7	OFF	OFF	OFF	ON	ON	ON	ON	ON	Slave Unit 7

Table 6.3 Address Settings of CAN ID (continued)

CAN ID	SW3-1	SW3-2	SW3-3	SW3-4	SW3-5	SW3-6	SW3-7	SW3-8	Note
8	ON	ON	ON	OFF	ON	ON	ON	ON	Slave Unit 8
9	OFF	ON	ON	OFF	ON	ON	ON	ON	Slave Unit 9
10	ON	OFF	ON	OFF	ON	ON	ON	ON	Slave Unit 10
11	OFF	OFF	ON	OFF	ON	ON	ON	ON	Slave Unit 11
12	ON	ON	OFF	OFF	ON	ON	ON	ON	Slave Unit 12
13	OFF	ON	OFF	OFF	ON	ON	ON	ON	Slave Unit 13
14	ON	OFF	OFF	OFF	ON	ON	ON	ON	Slave Unit 14
15	OFF	OFF	OFF	OFF	ON	ON	ON	ON	Slave Unit 15

NOTE: The Vertiv™ Liebert® iCOM™ Edge Controller can connect to 16 units. Unit CAN ID address must be set in sequence from 0 to 15.

NOTE: CAN ID 0 is master unit. Teamwork parameters only can be set in master unit and then shared to subordinate units. Subordinate unit uploads operation status and alarms to the master unit.

6.2.5 User Selectable Features

Pay special attention to the location of the grounding cable and the cable restrainer around the other electrical/communication cables when connecting.

Some contacts on the motherboard have been reserved for open functions for the customer's site. Prior to using them, refer to the following definitions of these ports.

Figure 6.7 Wiring Terminals

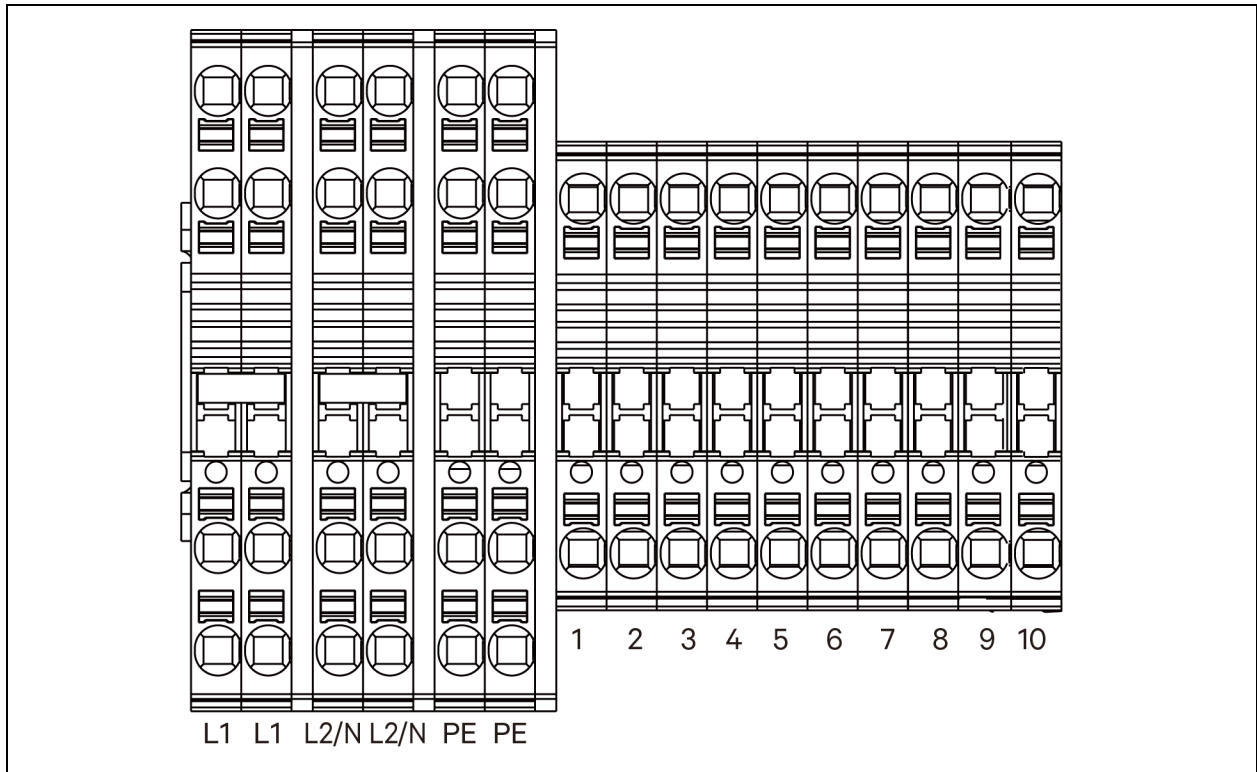

Table 6.4 Definition of Dry Contact

Terminal Point	Function	Signal Type	Polarity	Functional Description	Note
1&2	Remote Shutdown	Switch Detection Signals	/	When disconnected, the unit shutdown.	A jumper used here to short-circuit these two terminals at the factory. Customers need to remove the jumper and contact their device when using this function.
3&4	Humidifier control	Dry Contacts	NO	When the humidity is lower than the set value, the contact closes.	Contact capacity: 250VAC/30VDC 5A
5&6	Public Alarms	Dry Contacts	NC	When there is an alarm and the output of the alarm is enabled, the contact is disconnected.	/
7&8	Water Pump Fault Alarms	Switch Detection Signals	/	When disconnected or the pump is failure, the pump failure warning is displayed.	When using the water pump assembly, connect the water pump alarm wires here, which are gray and blue respectively.
9&10	Exhaust fan control	Dry Contacts	NO	When the unit is powered on and a refrigerant leak is detected, the contacts close.	Contact capacity: 250VAC/24VDC 5A

6.3 LCD Display Installation and Wiring

The display board is connected to the unit with a 9.8 ft (3 m) power cable as shown in **Figure 6.8** on the facing page.

Figure 6.8 LCD Display Cable Connections

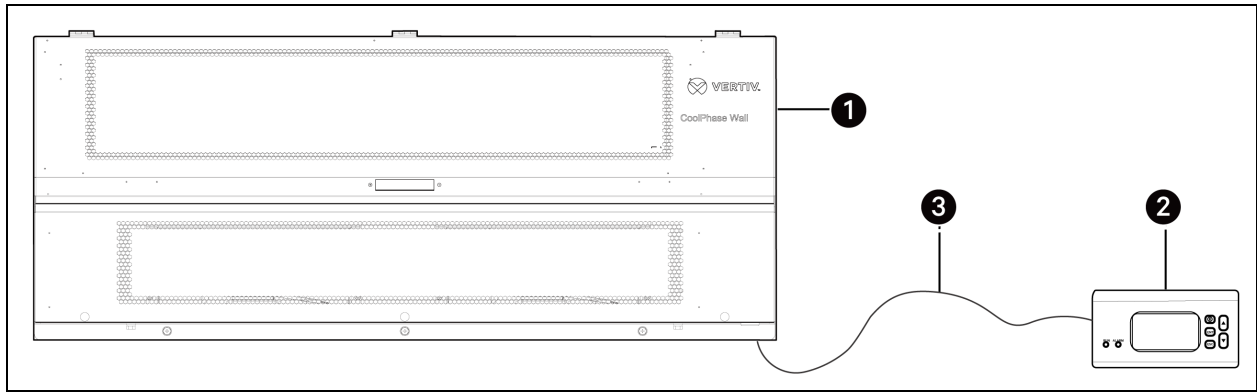

Item	Description	Item	Description
1	Indoor unit	3	Display cable
2	LCD display		

NOTICE

- Risk of improper smart display installation. Can cause unit malfunction.
- Installation work must be performed in accordance with the national wiring standards and local code by authorized personnel only.
- If local electrical and building codes require the use of vented duct (CMP) cable, use closed, non-flammable conduit (metal pipe) or change to FT-6 rated or higher cable.
- The 3-meter fully assembled harness for the display connection is factory provided and included within the packaging.
- AWG#22, 4 core shielded twisted pair cable is provided.

Figure 6.9 Harness Assembly

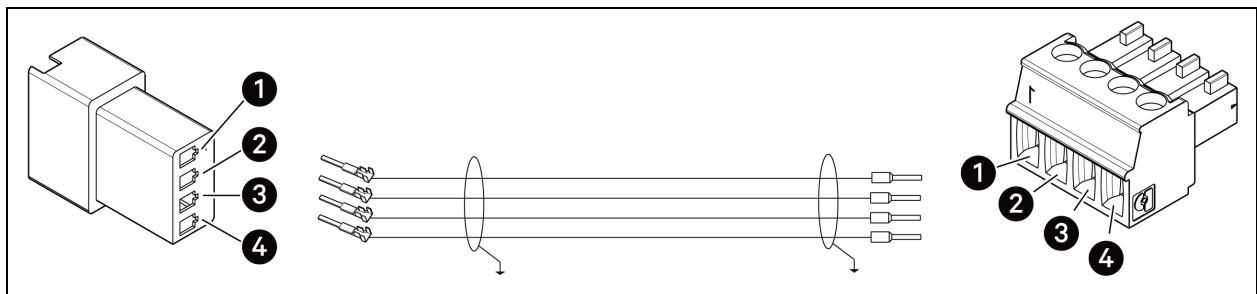

Item	Description	Item	Description
1	B -	3	12 V
2	A +	4	Ground

To install the LCD display:

NOTICE

If local electric and building code requires plenum (CMP) cable, use an enclosed, non-combustible conduit (metal raceway) or change to FT-6 rated or above cable.

NOTE: When assembling the harness, identify the connectors position with the counterpart of the indoor unit and LCD display.

1. Refer to **Figure 6.10** below to connect the indoor unit to the LCD display using its harness.
2. One side of the harness connects to the LCD display; another side connects to LCD display terminal of indoor unit.

Figure 6.10 Example of How the Harness Would Look Once Assembled

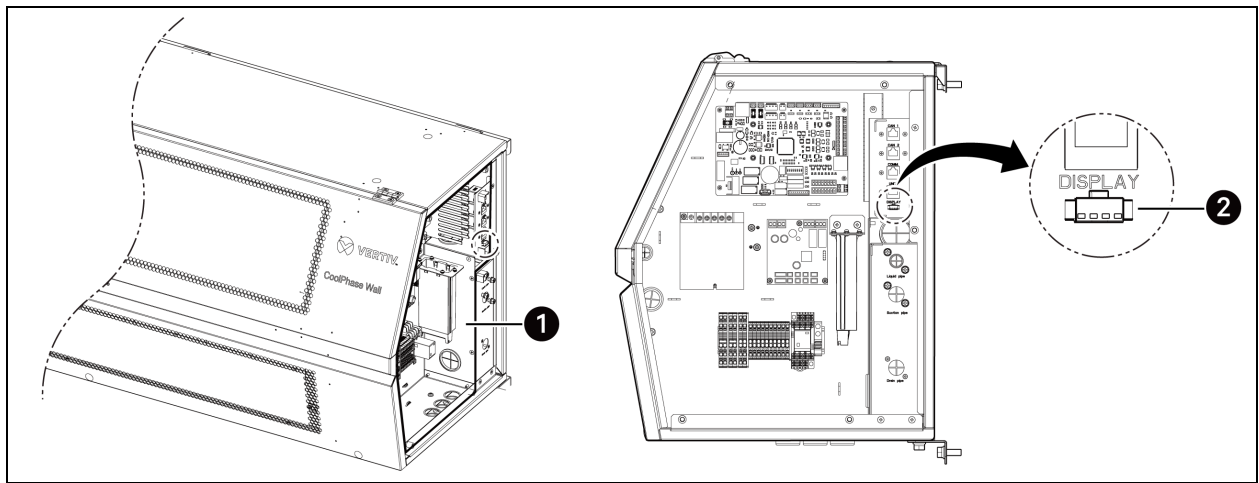

Item	Description
1	Electrical box (E-box)
2	LCD display terminal

NOTE: Make sure connectors are properly connected.

NOTE: For more information refers to the electric diagrams on Appendix A.

7 Installation Checklist

7.1 Piping Checklist

Major Component Rough-in

1. Unit was connected properly per local code and the product installation procedures.
2. All obstructions have been removed from the fan discharge.
3. Indoor unit was installed, properly supported, and located indoors in a non-corrosive environment.
4. Unit's gravity condensate drain line was connected and routed where it properly drains away or, if installed in a mechanical room, was connected and properly routed to a drain terminal.

Piping and Insulation

1. Over 5/8 in (15.9 mm)—Rigid ACR only
2. 5/8 in (15.9 mm) and under—can use soft ACR.
3. All refrigerant pipes and valves were insulated separately. Insulation butts up against the walls of the indoor units. No gaps or cracks. Insulation was not compressed at clamps and hangers.

Brazing Practices

1. Use dry nitrogen for purging during brazing was used (constant 3 psi (21 kPa) while brazing).
2. 15% silver brazing material only.

Refrigerant Piping

1. All pipe materials were properly stored, capped, and clean. All burrs were removed after cutting and pipe ends were reamed before brazing.
2. During refrigerant pipe installation, for each segment of pipe, a record was made of the pipe length (including expansion loops, offsets, double-back sections), and sizes, as well as the quantity and type of elbows used.
3. All long runs of straight pipe were provided with expansion loops.
4. A torque wrench and backup wrench were used to tighten all flare connections.
5. The back side of all flares were lubricated with a small drop of FW68S refrigeration oil before tightening flare fittings.
6. Ensure all field-made flares are 45°. Used factory-supplied flare nuts only.
7. Pipe segments were properly supported and all wall penetrations were sleeved.
8. Pipe insulation was not compressed at any point.
9. No oil traps, solenoid valves, sight glasses, filter driers, or any other unauthorized refrigerant specialties were present.
10. Best practice including a minimum of 20 in (51 cm) straight pipe was installed between each elbow.

7.2 Electrical Installation Checklist

After the system electrical installation is completed, the following requirements should be met.

Table 7.1 Electrical Inspection Checklist

Particulars
The system electrical loop has no open-circuit or short-circuit exists in the electrical connection.
The power supply voltage meets the rated voltage on the nameplate of the unit.
Confirm, if the power cables and ground cables are connected to the terminal blocks, indoor unit, and outdoor unit correctly as per the norms.
The control cables are configured and subsequently, fixed properly.
All the cables and connector connections, including the fixing blocks, are firmly and appropriately fixed.

Power Wire and Communication Cables

1. Power wiring was connected to a single-phase 208/230V, 1ph, 50/60Hz source.
2. Ground wire was installed and properly terminated at the unit.
3. The power supplied was clean with voltage fluctuations with specifications. ($\pm 10\%$ of nameplate).
4. Power wiring was installed per all local electrical code requirements.
5. Communication CAN BUS and type RS-485-BUS type.
6. Ethernet cables (RJ45) for all communication connections.
7. Used appropriate crimping tool to attach terminals at all power wiring and control cable terminations.
8. All power and control wires were properly separated using the recommended distance provided in the installation manual.

8 Commissioning

8.1 Self Check

Table 8.1 Start-up Inspection Checklist

Item	Content
Room environment	Thermal isolation and moisture proof materials are installed.
Mounting base	The vibration absorbing material between the base and the unit is installed
Display panel	The surface is clean and there is no sign of damage.
Filter	All the filters are installed in the right positions and are in good condition.
Unit	The unit is installed in the correct position. Pipes are properly supported and have the correct inclination. The oil trap is installed in the correct position.
Fan	Air inlet and outlet areas are not blocked. The fan blades rotate freely, without sticking or abnormal noise.
Power supply	Voltage, phase rotation, and frequency of both indoor and condensing units are within normal range. Power supply cables are connected correctly. All circuit breakers and contactors are properly connected.
ICOM Edge	All communication cables are in good condition.
Pipes	Pipes are connected correctly. No copper pipes are exposed, and thermal insulation is properly applied.

8.2 Charging Refrigerant and Lubricating Oil

NOTICE

Vertiv™ CoolPhase Wall unit is designed to be connected with the Vertiv™ CoolPhase Condensing Unit family. Refrigerant charge is determined in the field during the installation of the whole refrigerant system. However, these units require a minimum refrigerant charge to work correctly and to avoid damage.

Before starting with the refrigerant charge and oil lubrication, review the Important Safety Instructions chapter in this manual.



WARNING! This Unit shall be connected only to a Condensing Unit suitable for R32 refrigerant.



WARNING! Every working procedure that affects safety must be conducted by competent persons.



WARNING! Risk of over-pressurization of the refrigeration system. Can cause serious injury or death. Can cause explosive discharge of high-pressure refrigerant, loss of refrigerant, environmental pollution, equipment damage, injury, or death. This unit contains fluids and gases under high pressure. Use extreme caution when charging the refrigerant system. Do not pressurize the system higher than the design pressure marked on the unit's nameplate.

NOTE: The unit is shipped from the factory without refrigerant. Before operation, refrigerant must be charged on site. Only R32 refrigerant is to be used for this unit.

NOTE: Do not use poor-quality or wrong-type refrigerant and lubricating oil, as they can damage the system.

NOTE: The unit has been charged with certain amount of lubricating oil in the factory.

1. If the condensing unit is standard ambient unit and the liquid pipe between the indoor unit and condensing unit is less than 82 ft (25 m), not add extra lubricating oil. Otherwise, must add the lubricating oil, the lubricating oil for the unit is (FW68S).
2. If the condensing unit is low ambient unit and the liquid pipe between the indoor unit and condensing unit is less than 49.2 ft (15 m), not add extra lubricating oil. Otherwise, must add the lubricating oil, the lubricating oil for the unit is (FW68S).

NOTE: Before charging the lubricating oil and refrigerant, please confirm that the Hi and Lo knobs on the gauge are open, and that the suction valve and liquid valve of the condensing unit are also open

In addition to conventional charging procedures, the following requirements shall be followed:

- Ensure that contamination of different refrigerants does not occur when using charging equipment. Hoses or lines shall be as short as possible to minimize the amount of refrigerant contained in them.
- Cylinders shall be kept in an appropriate position according to the instructions.
- Ensure that the refrigerant system is earthed before charging the system with refrigerant.
- Label the system when charging is complete. Indoor and condensing units are provided with locations where the total refrigerant charge can be written.
- Extreme care shall be taken not to overfill the refrigerant system.

8.2.1 Amount of Refrigerant and Lubricating Oil

NOTE: Due to the use of R-32 refrigerant classified as A2L, all units with a refrigerant charge above 4.06 lb (1.842 kg) shall be installed in a location with a minimum room area. See the **Table 8.2 on the facing page for more details as applicable.**

Table 8.2 Refrigerant and Lubricating Charging Amount

Model / Capacity	Length ft (m)	Liquid Line Diameter ANSI (DIN)	Suction Line Diameter ANSI (DIN)	Total Ref Charge: Unit With Standard Ambient Condensing Unit lb (kg)	Total Ref Charge: Unit With Low Ambient Condensing Unit lb (kg)	Extra Lubricant Oil: Unit With Standard Ambient Condensing Unit fl oz (ml)	Extra Lubricant Oil: Unit With Low Ambient Condensing Unit fl oz (ml)	Minimum Room Floor Area ft ² (m ²)
WLM030A be paired with CUD030-E000A or CUL030-E000A	16.4 (5)	1/4 (6.35)	1/2 (12.7)	1.65 (0.75)	2.76 (1.25)	0.00 (0)	0.00 (0)	48.70 (4.52)
	32.8 (10)	1/4 (6.35)	1/2 (12.7)	1.90 (0.86)	3.00 (1.36)	0.00 (0)	0.00 (0)	52.98 (4.92)
	49.2 (15)	3/8 (9.52)	1/2 (12.7)	2.67 (1.21)	3.77 (1.71)	0.00 (0)	1.69 (50)	66.62 (6.19)
	65.6 (20)	3/8 (9.52)	1/2 (12.7)	3.17 (1.44)	4.28 (1.94)	0.00 (0)	3.38 (100)	75.58 (7.02)
	82 (25)	3/8 (9.52)	1/2 (12.7)	3.68 (1.67)	4.78 (2.17)	1.69 (50)	5.07 (150)	84.54 (7.85)
	98.4 (30)	3/8 (9.52)	1/2 (12.7)	4.19 (1.9)	5.29 (2.40)	3.38 (100)	6.76 (200)	93.50 (8.69)
	114.8 (35)	3/8 (9.52)	1/2 (12.7)	4.70 (2.13)	5.80 (2.63)	5.07 (150)	8.45 (250)	102.46 (9.52)
	131.2 (40)	3/8 (9.52)	1/2 (12.7)	5.20 (2.36)	6.31 (2.86)	6.76 (200)	10.14 (300)	111.42 (10.35)
	147.6 (45)	3/8 (9.52)	1/2 (12.7)	5.71 (2.59)	6.81 (3.09)	8.45 (250)	11.83 (350)	120.38 (11.18)
	164 (50)	3/8 (9.52)	1/2 (12.7)	6.22 (2.82)	7.32 (3.32)	10.14 (300)	13.53 (400)	129.34 (12.02)
	180.4 (55)	3/8 (9.52)	1/2 (12.7)	6.72 (3.05)	7.83 (3.55)	11.83 (350)	15.22 (450)	138.30 (12.85)
	196.8 (60)	3/8 (9.52)	1/2 (12.7)	7.23 (3.28)	8.33 (3.78)	13.53 (400)	16.91 (500)	147.26 (13.68)
WLM070A be paired with CUD070-E000A or CUL070-E000A	16.4 (5)	3/8 (9.52)	1/2 (12.7)	2.09 (0.95)	3.20 (1.45)	0.00 (0)	0.00 (0)	56.49 (5.25)
	32.8 (10)	3/8 (9.52)	1/2 (12.7)	2.60 (1.18)	3.70 (1.68)	0.00 (0)	0.00 (0)	65.45 (6.08)
	49.2 (15)	3/8 (9.52)	5/8 (15.88)	3.11 (1.41)	4.21 (1.91)	0.00 (0)	3.38 (100)	74.41 (6.91)
	65.6 (20)	3/8 (9.52)	5/8 (15.88)	3.62 (1.64)	4.72 (2.14)	0.00 (0)	5.07 (150)	83.37 (7.75)
	82 (25)	3/8 (9.52)	5/8 (15.88)	4.12 (1.87)	5.22 (2.37)	3.38 (100)	6.76 (200)	92.33 (8.58)
	98.4 (30)	3/8 (9.52)	5/8 (15.88)	4.63 (2.1)	5.73 (2.60)	5.07 (150)	8.45 (250)	101.29 (9.41)
	114.8 (35)	3/8 (9.52)	5/8 (15.88)	5.14 (2.33)	6.24 (2.83)	6.76 (200)	10.14 (300)	110.25 (10.24)
	131.2 (40)	1/2 (12.7)	5/8 (15.88)	8.51 (3.86)	9.61 (4.36)	18.60 (550)	21.98 (650)	169.95 (15.78)
	147.6 (45)	1/2 (12.7)	5/8 (15.88)	9.41 (4.27)	10.52 (4.77)	21.98 (650)	25.36 (750)	185.83 (17.26)
	164 (50)	1/2 (12.7)	5/8 (15.88)	10.34 (4.69)	11.44 (5.19)	25.36 (750)	28.74 (850)	202.19 (18.78)
	180.4 (55)	1/2 (12.7)	5/8 (15.88)	11.24 (5.1)	12.35 (5.60)	28.74 (850)	32.12 (950)	218.16 (20.27)
	196.8 (60)	1/2 (12.7)	5/8 (15.88)	12.17 (5.52)	13.27 (6.02)	32.12 (950)	35.50 (1050)	234.52 (21.79)

Table 8.2 Refrigerant and Lubricating Charging Amount (continued)

Model / Capacity	Length ft (m)	Liquid Line Diameter ANSI (DIN)	Suction Line Diameter ANSI (DIN)	Total Ref Charge: Unit With Standard Ambient Condensing Unit lb (kg)	Total Ref Charge: Unit With Low Ambient Condensing Unit lb (kg)	Extra Lubricant Oil: Unit With Standard Ambient Condensing Unit fl oz (ml)	Extra Lubricant Oil: Unit With Low Ambient Condensing Unit fl oz (ml)	Minimum Room Floor Area ft ² (m ²)
WLM110A be paired with CUD111-E000A, or CUL111-E000A, or CUD115-E000A, or CUL115-E000A	16.4 (5)	3/8 (9.52)	5/8 (15.88)	2.65 (1.2)	4.30 (1.95)	0.00 (0)	0.00 (0)	75.97 (7.06)
	32.8 (10)	3/8 (9.52)	5/8 (15.88)	3.15 (1.43)	4.81 (2.18)	0.00 (0)	0.00 (0)	84.93 (7.89)
	49.2 (15)	3/8 (9.52)	5/8 (15.88)	3.66 (1.66)	5.31 (2.41)	0.00 (0)	3.38 (100)	93.89 (8.72)
	65.6 (20)	3/8 (9.52)	5/8 (15.88)	4.17 (1.89)	5.82 (2.64)	0.00 (0)	5.07 (150)	102.85 (9.55)
	82 (25)	1/2 (12.7)	3/4 (19.05)	6.31 (2.86)	7.96 (3.61)	6.76 (200)	13.53 (400)	140.64 (13.07)
	98.4 (30)	1/2 (12.7)	3/4 (19.05)	7.23 (3.28)	8.88 (4.03)	10.14 (300)	16.91 (500)	157.00 (14.59)
	114.8 (35)	1/2 (12.7)	3/4 (19.05)	8.14 (3.69)	9.79 (4.44)	13.53 (400)	20.29 (600)	172.97 (16.07)
	131.2 (40)	1/2 (12.7)	3/4 (19.05)	9.06 (4.11)	10.71 (4.86)	16.91 (500)	23.67 (700)	189.33 (17.59)
	147.6 (45)	1/2 (12.7)	3/4 (19.05)	9.96 (4.52)	11.62 (5.27)	20.29 (600)	27.05 (800)	205.31 (19.07)
	164 (50)	1/2 (12.7)	7/8 (22.23)	10.89 (4.94)	12.54 (5.69)	23.67 (700)	30.43 (900)	221.67 (20.59)
	180.4 (55)	1/2 (12.7)	7/8 (22.23)	11.79 (5.35)	13.45 (6.10)	27.05 (800)	33.81 (1000)	237.64 (22.08)
	196.8 (60)	1/2 (12.7)	7/8 (22.23)	12.72 (5.77)	14.37 (6.52)	30.43 (900)	37.20 (1100)	254.00 (23.60)

If the refrigerant charge falls between the length and the refrigerant charge stated in **Table 8.2** on the previous page, please charge the amount of smaller one. For example, when the pipe is 18m, please charge the lubricating oil and refrigerant the same as the 15m.

If the unit is installed within a room with a smaller room area it is required to provide additional ventilation for the room, please review ASHRAE 15, ASHRAE 15.2, EN IEC Safety standard 60335-2-40 or UL/CSA Safety Standard 60335-2-40 for more information on how to provide adequate ventilation.

8.2.2 Adding Lubricating Oil

NOTE: After charging the refrigeration oil, vacuum the system again.

After evacuating the unit (in section 5.2.8), as indicated in the next section, remove the vacuum pump and connect the lubricating oil tank to the manifold valve, the oil is drawn into the unit. Repeat this procedure (evacuating and then adding oil) several times until the required amount of oil is added.

NOTE: Exhaust the air of tube and oil tank before the tube into the oil tank, ensure that no air is absorbed into the system. As an optional approach, the lubricating oil can be charged by falling the oil into the suction pipe advanced when connect the suction pipes.

Figure 8.1 Service Valves in the System

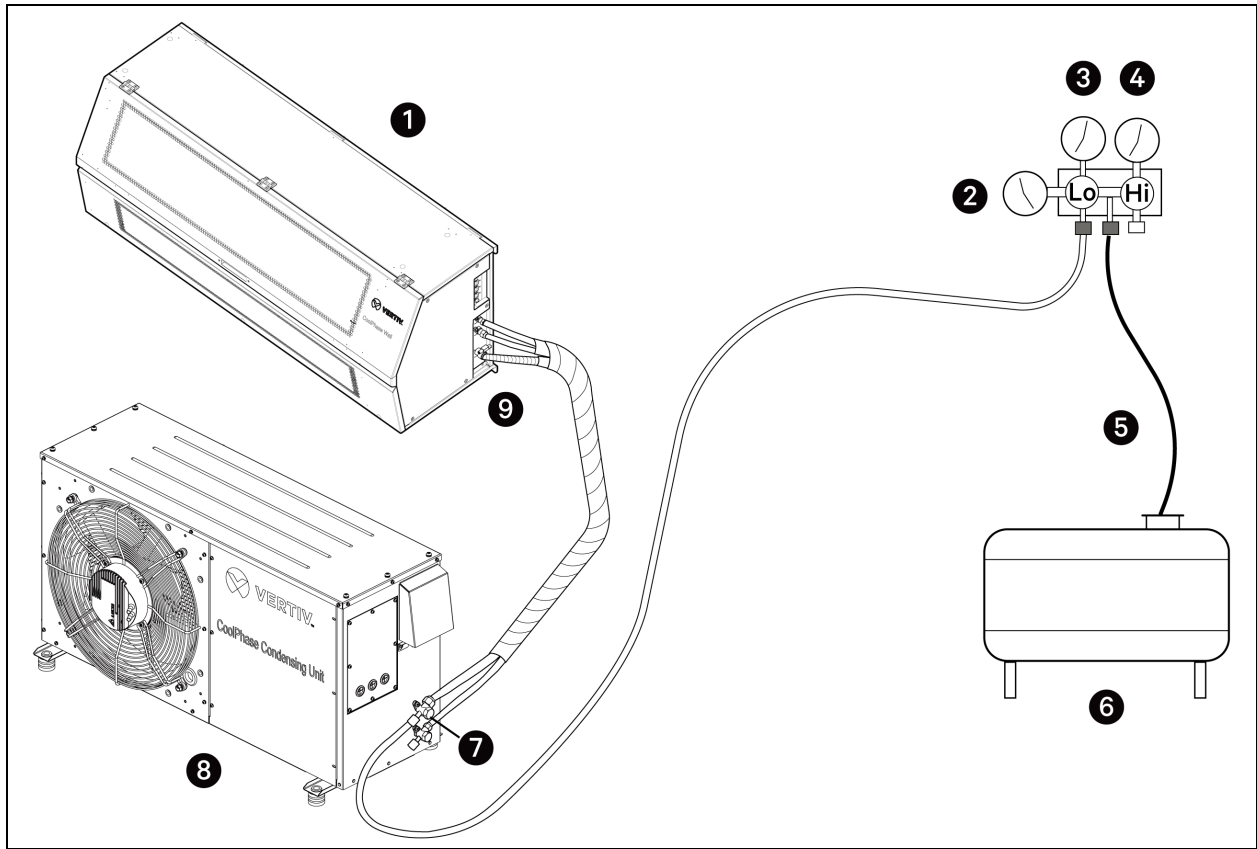

Item	Description	Item	Description
1	Indoor unit	6	Oil tank
2	Pressure gauge	7	Service valve
3	Manifold valve – Suction side	8	Condensing Unit
4	Manifold valve – Liquid side	9	Piping bundle
5	Charge hose		

8.2.3 Charging Refrigerant Staticly

NOTE: Do not overcharge the unit. Charge it dynamically only if it is not charged with enough refrigerant.

NOTE: After charging the refrigerants staticly, do not turn on the compressor to charge the refrigerant dynamically until the compressor has been pre-heated for more than 12 hours.

Connect a manifold gauge to the refrigerant cylinder. Purge the air out of hoses. Connect the manifold gauge to the service valve (liquid valve or gas valve), as shown in **Figure 8.2** on the next page Charge the refrigerant diagram.

Figure 8.2 Charging Refrigerant Diagram

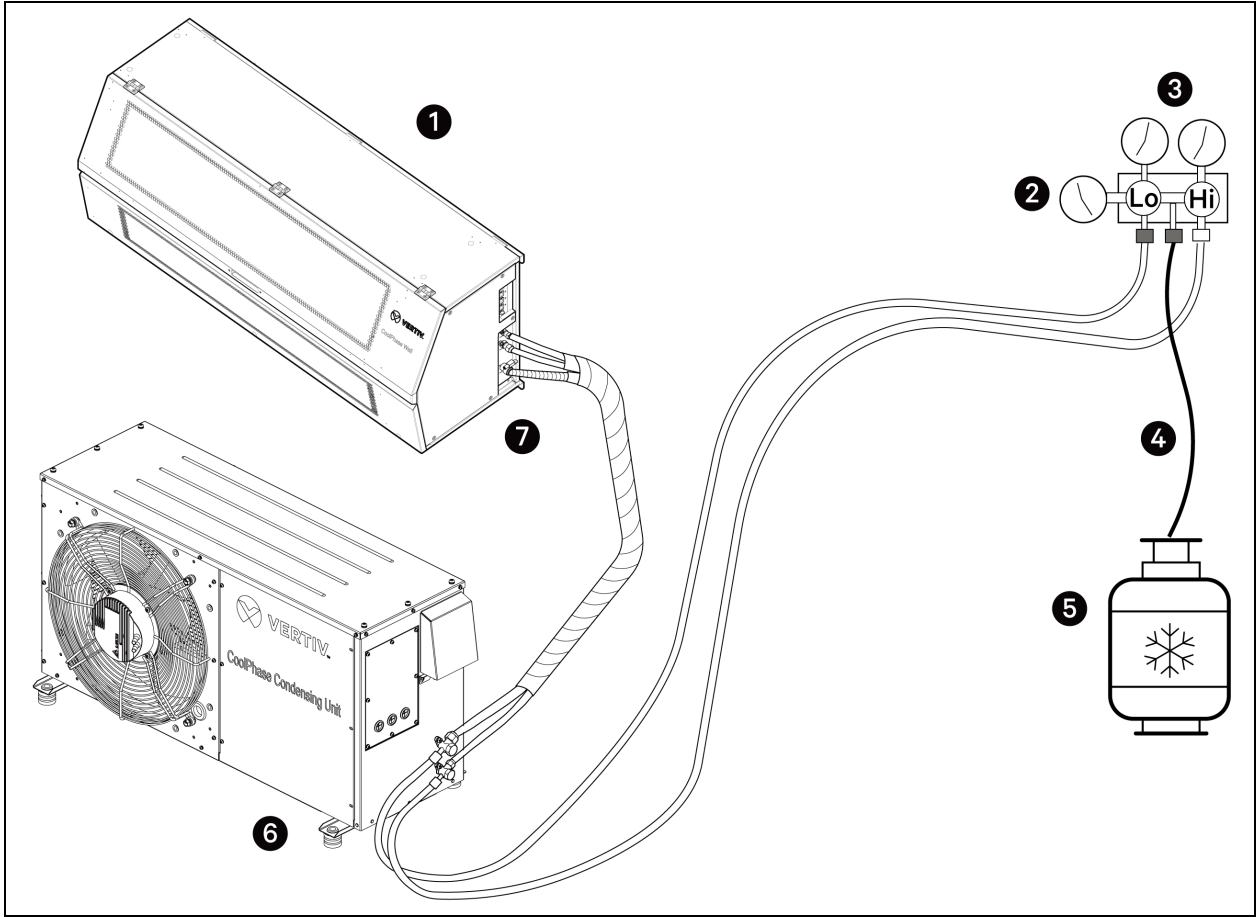

Item	Description	Item	Description
1	Indoor unit	5	Refrigerant cylinder
2	Pressure gauge	6	Condensing Unit
3	Manifold valve	7	Piping bundle
4	Charge hose		

8.2.4 Charging Refrigerant Dynamically

NOTE: Please keep the “Hi” knob closed when charging the refrigerant dynamically.

NOTE: Do not charge the unit too fast. Otherwise, the compressor can be damaged.

NOTE: To dynamically charge the unit, the recommended charge must be calculated and weighed using a charging scale

To charge the refrigerant dynamically:

1. Start the unit, on the LCD display of the indoor unit
2. Press and hold the ON/OFF button for three seconds
3. Select Maintenance > Manual Mode

4. Select Yes to Enable Manual Mode
5. Set the fan output value to 75%
6. Set the Manual CFan to YES and set the CFan output to 75%
7. Wait 5 minutes and start the compressor
8. Adjust the output to 72%.
9. Connect the refrigerant cylinder to the manifold gauge, as shown in **Figure 8.3** below. After the compressor starts, the refrigerant is drawn into the unit

After charging the refrigerant dynamically, if the unit is to be powered off, hold the ON/OFF button on the LCD display. Do not power off the unit by turning off the circuit breakers, as this may damage the compressor.

! **CAUTION: Dynamic charging of refrigerant is strictly prohibited with the refrigerant bottle upside down.**

Figure 8.3 Charging Refrigerant Diagram

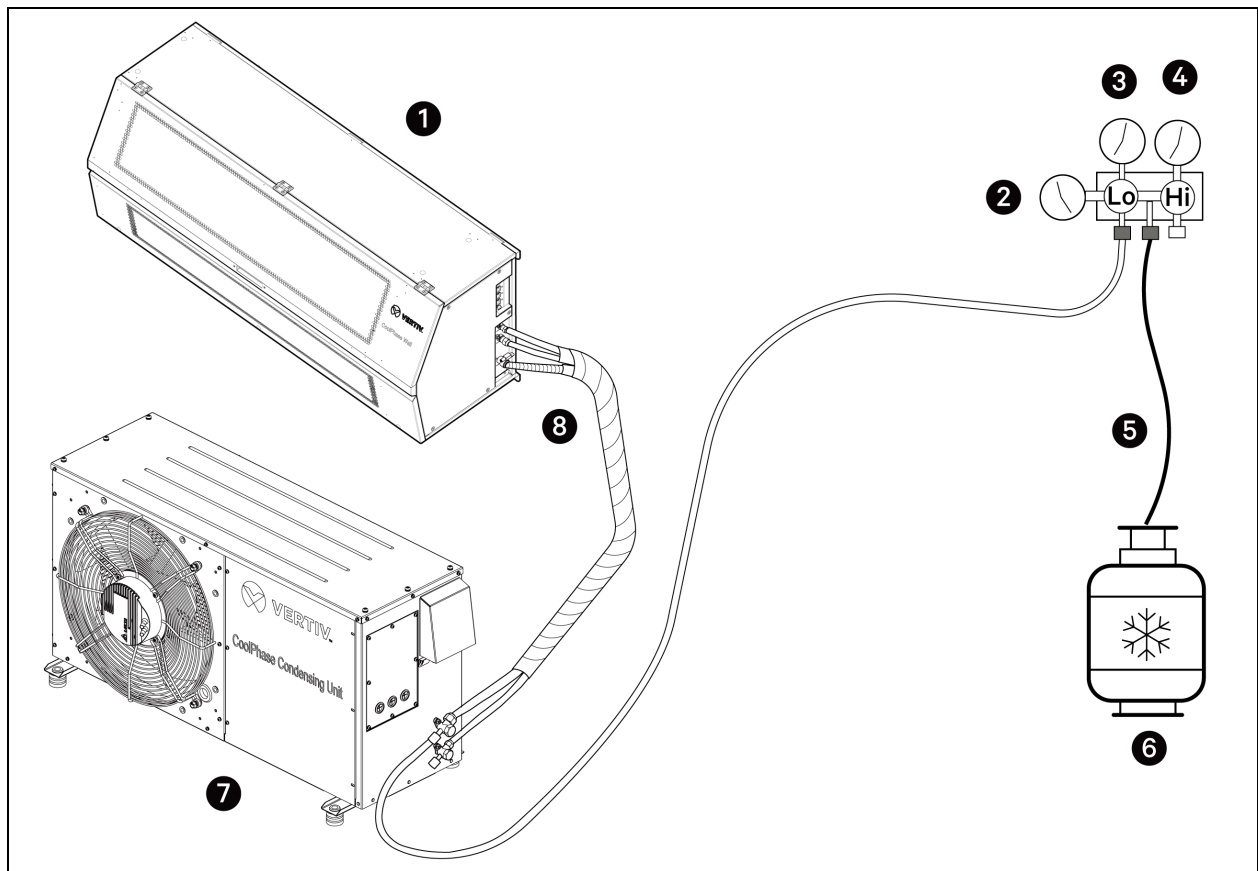

Item	Description	Item	Description
1	Indoor unit	5	Charge hose
2	Pressure gauge	6	Refrigerant cylinder
3	Manifold valve – Suction side	7	Condensing Unit
4	Manifold valve – Liquid side	8	Piping bundle

8.3 Start-up Procedure

8.3.1 First Start-up (or After Long Standstill)

To prevent the compressor from damaging, preheat the compressor for at least 12 hours before starting the unit (the compressor is preheated by its crankcase heater). Start the unit as follows.

1. Open all valves in the system according to the instruction labels attached to the valves.
2. Using a leak detector, verify that there are no refrigerant leaks. If there are any, then repair the leak and recharge the refrigerant.
3. At least 4 hours before start-up, close the main switch and the circuit breaker for transformer protection on the electrical panel. The LCD display will turn on immediately to indicate the presence of electrical power. If the screen does not light up, check the main power supply.
4. Check that there are no water leaks.
5. Check if the supply voltage is normal. If so, switch on all the circuit breakers.
6. Ensure that the compressor has been preheated for at least 4 hours before starting the unit.
7. Start the unit by pressing and holding the ON/OFF button on the LCD display for three seconds.
8. Ensure that all control system settings are correct and that there are no alarms.
9. Once the system is operating under load, conduct the following checks:
 - Verify that the fans are operating properly.
 - Ensure that the temperature is reached, and that the accessories operate when required.
 - Ensure that the compressor operates when required.
 - Ensure that the indoor unit controller is calibrated correctly, and that it controls the fan operation.
 - Ensure that all the sensors have been calibrated.

NOTE: The Supply and Return temperature values are factory set; they may be adjusted if necessary.

NOTE: If the installation is not set correctly, it can cause problems for the product, user injury, or property damage. A certified technician must perform installation set-up. Non-certified personnel attempting to install or make changes shall be responsible for any adverse effects or operation

9 LCD Display

This chapter gives a detailed description of the features, appearance, LCD screen, control buttons, control interface and menu structure of the indoor unit.

9.1 LCD Display Overview

The LCD display is 128 × 64 dot screen with white backlight, symbolic representation of unit functions, diagnostics feature. A buzzer provides audible indication in case of the 'Warning' or 'Alarm' event.

9.2 LCD Display and Control Buttons

The LCD screen displays menus in English, Spanish, French, Italian, Polish, and German. **Figure 9.1** below the controller display.

NOTE: If no language has been picked, the language selection menu is displayed upon power up. If no action is taken, after 15 seconds the home menu is displayed.

The micro-processing controller provides control buttons, as shown below.

Figure 9.1 Smart Display Front View and Control Buttons

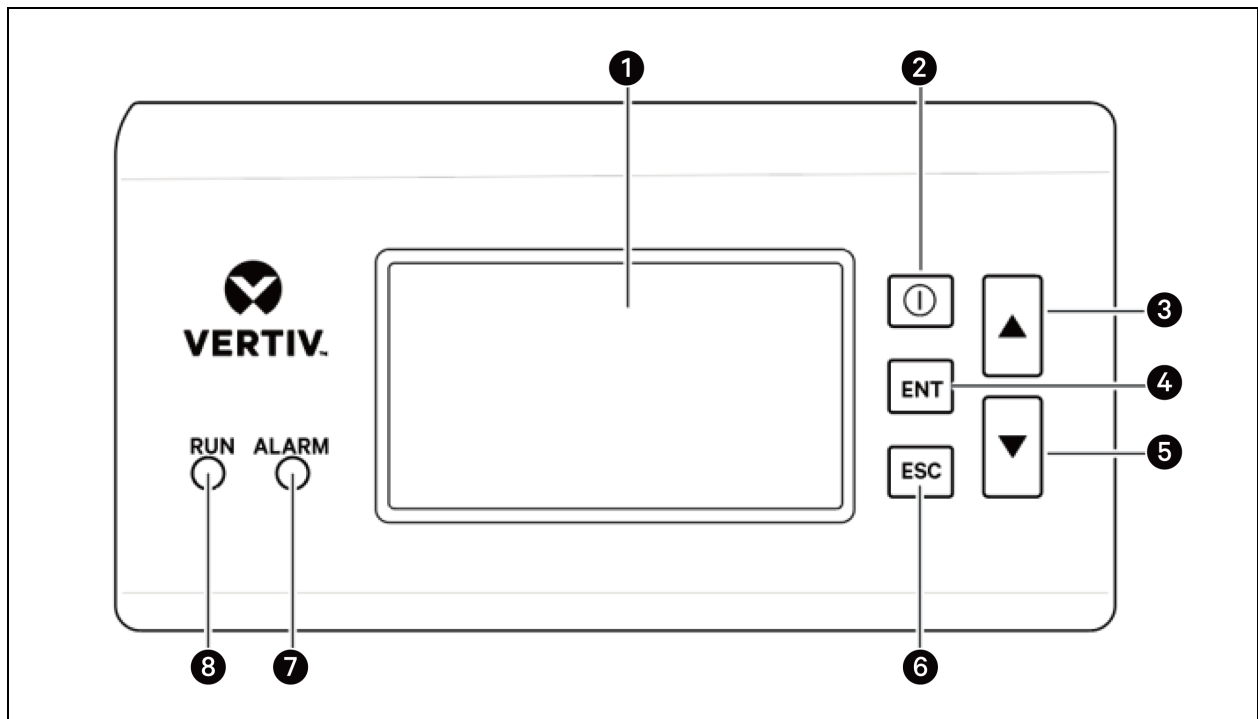

Item	Description	Item	Description
1	LCD Screen	5	Scroll Down Arrow
2	ON/ OFF button	6	Escape button
3	Scroll Up Arrow	7	Alarm Indicator

Item	Description	Item	Description
4	ENT Button	8	Run Indicator

The functions of the control buttons are described in [Functional Description of the Controller Buttons](#) below.

Table 9.1 Functional Description of the Controller Buttons

Item	Key	Function description
1	LCD Screen	128 × 64 dot screen with white backlight
2	ON/OFF	Switch on/off the controller by pressing for 3s
3	Up button	Move the cursor up or increase the parameter value. For a toggle selection: scroll through the options. For a multi-screen menu: scroll up the screen. Long press to increase values continuously.
4	ENT (Enter button)	Enter the selected menu screen. Validate the parameter setting value
5	Down button	Move the cursor down or decrease the parameter value. For a toggle selection: scroll through the options. For a multi-screen menu: scroll down the screen. Long press to decrease values continuously.
6	ESC button	Exit the current menu and return to the Normal screen or previous menu screen. Abort parameter change; make the audible alarm silent.
7	Alarm Indicator (red led)	a) LED off when no alarm is present b) LED blinks at a 2 Hz rate when a new alarm is present c) LED is Solid when alarm is present and acknowledged
8	Run Indicator (green led)	a) LED blinks at a 1/2 Hz rate when unit is OFF or LOCK mode b) LED is Solid On when the unit is ON or Standby mode c) LED blinks at a 2 Hz rate when in Manual Mode d) LED is OFF if there is no power to the Display/Controller

9.2.1 On Screen / Home Page

When the unit is powered on, the LCD screen displays the ON screen. If not already set, you will be prompted to select a language. The screen times out after 15 seconds of inactivity.

When a language is selected or the screen times out, the Home Screen is displayed.

9.2.2 Normal Screen / Control Mode

After the display board language is selected, the Normal screen is displayed, as shown in [Main Screen](#) on the facing page.

NOTE: The temperature of the Vertiv™ CoolPhase Wall unit can be displayed in Celsius or Fahrenheit.

Figure 9.2 Main Screen

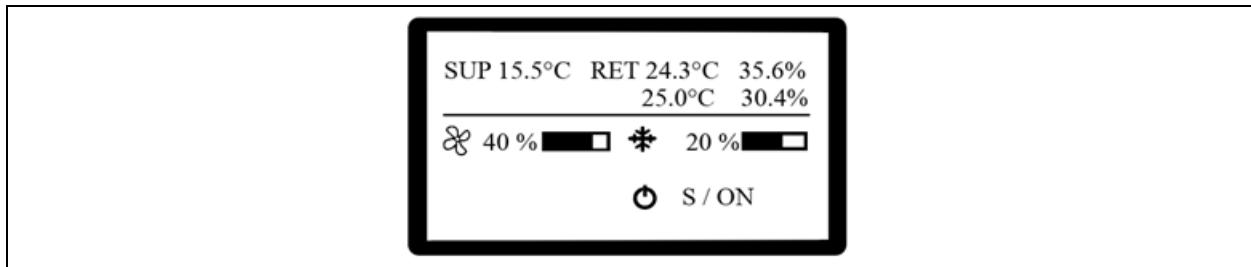

The setting and actual values are displayed in the upper half of the screen related to the settings, actual air supply temperature in the first column, air return temperature in the second column, and humidity in the third column. The unit output status (fan and cooling) and unit operation status (On, Off, Standby, Manual and Lock) are displayed in the lower part of the screen. S (Single) or T (Teamwork) is shown next to the operating status. The icons on the main screen indicate the unit output status and unit operating status.

9.3 Unit Working Icons

The icons and their definitions are listed in **Table 9.2** below.

Table 9.2 Description of Icons

Icon	Description
SUP	Supply air temperature setpoint
RET	Specified return temperature
	Cooling, the output of compressor. Displays the percentage of actual compressor capacity
	Rotating speed rate of the fan. Displays the percentage of actual fan rotating speed
	Unit attribute/running state. S: standalone; RUN: running; OFF: shutdown. Unit property/operation status. S: single; ON: running; R-OFF: remote shutdown; D-OFF: Display Shutdown; M-OFF: monitoring shutdown; MANU: manual mode; Lock: Alarm lock

9.4 User Menu Structure and Parameters

On the Main screen, press the ENT (enter) button to enter the user menu. Refer to [Menu Structure](#) on page 131. To modify parameters, enter the password 1490.

Figure 9.3 Menu Structure

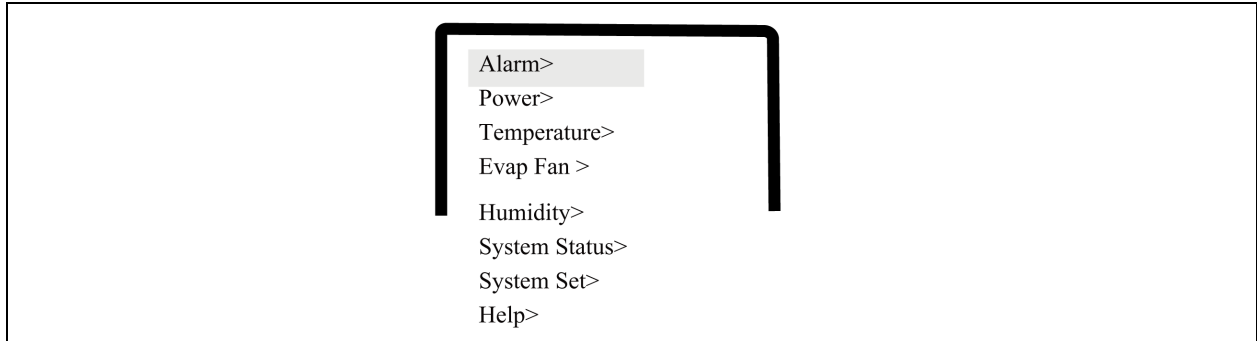

9.4.1 Alarm Menu

Press the menu button and choose Alarm Menu to check active alarms and historical alarms. Active Alarms show the active alarms and the time they are generated.

NOTE: Alarms are displayed in time sequence, starting with the latest one.

On the Main Menu screen, select Alarm, as [Figure 9.4](#) below. Press the Up or Down button to scroll up or down the menu items.

Figure 9.4 Alarm Menu Screen

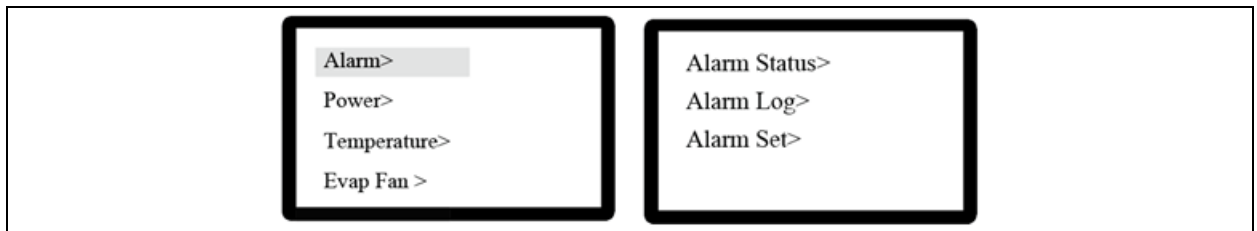

9.4.2 Alarm Status

Alarm status menu monitors the current alarm status of the air conditioner unit. It displays no alarm or specific alarm information. The specific alarm information includes XX/YY, alarm type, and alarm generation time, as shown in **Figure 9.5** below. Indicates the specific alarm shown on the display (XX), out of the total amount of reported alarms (YY).

Figure 9.5 Current Alarm Menu

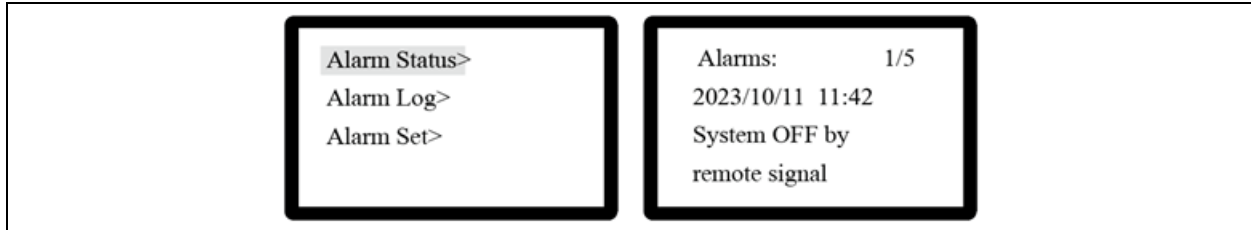

The latest alarm SN is the biggest number. Press the Up or Down button to scroll through the alarm status records if more than one alarm is activated. The current alarms are automatically cleared upon system power failure.

9.4.3 Alarm Log

Figure 9.6 below the alarms historical records.

Figure 9.6 Historical Alarm Example

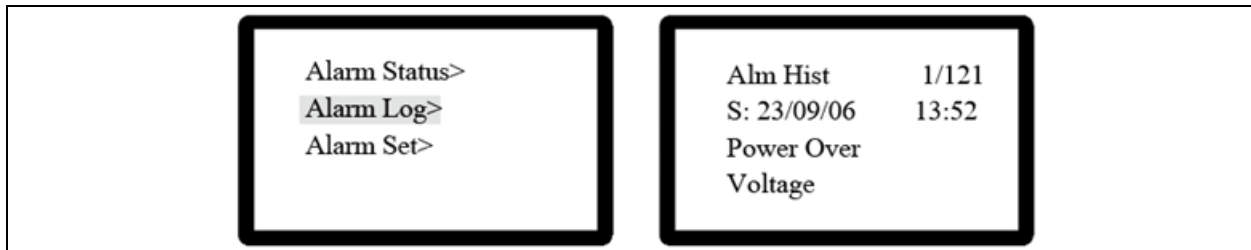

9.4.4 Alarm

Enter the alarm setup screen on the Alarm Setup menu. Use the Up or Down key to query menu items. The alarm setup menu includes Alarm Setpoint, System Alarms, and Alarm Handle. Parameter settings can be saved permanently.

Figure 9.7 Alarm Setpoint Menu

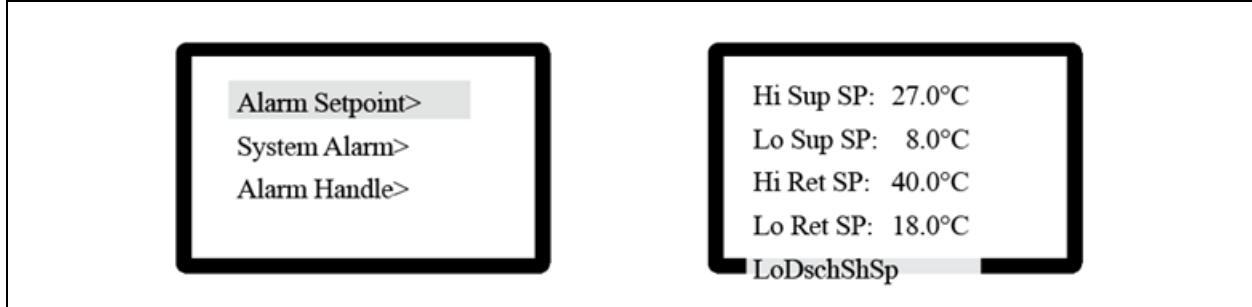

NOTE: For System Alarm Setup Menu, refer to [Menu Structure](#) on page 131.

Figure 9.8 Alarm Handle Menu

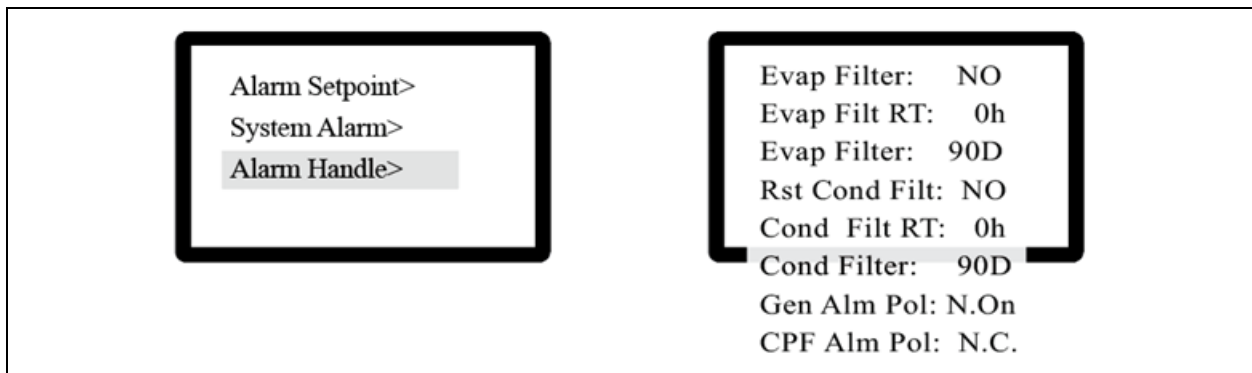

9.4.5 Power Menu

Select Main Menu > Power and press Enter, the power values of Line, Frequency, overvoltage, low voltage, and the power alarm and phase loss setpoints is displayed as shown in [Figure 9.9](#) below.

Figure 9.9 Power Menu

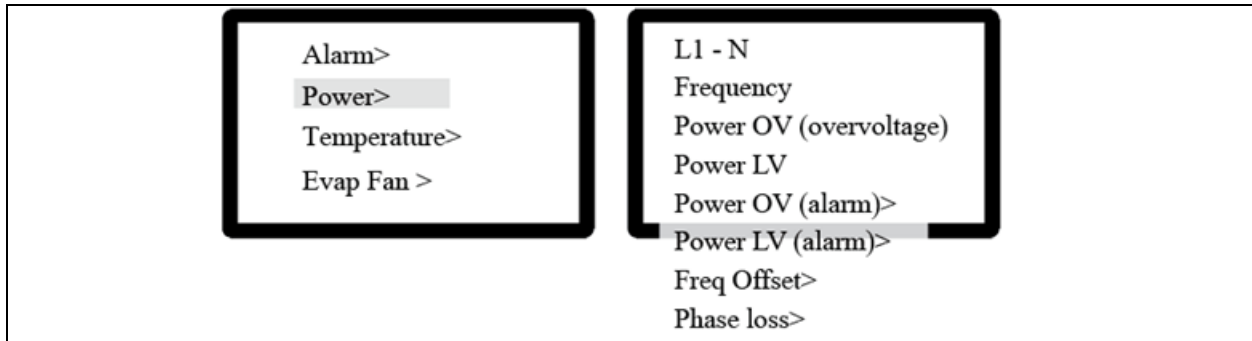

9.4.6 Temperature Set

Select Main Menu > Temperature and press Enter to set the temperature values of Return and Supply as shown in **Figure 9.10** below. The temperature settings are saved.

Figure 9.10 Temperature

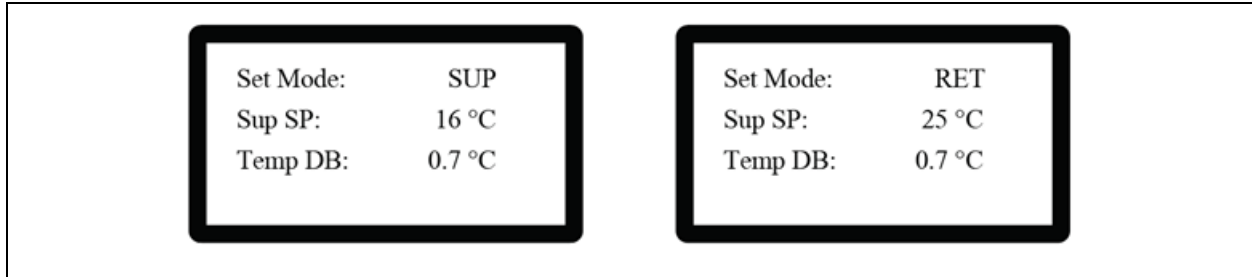

NOTE: The specified temperature value is the target temperature to ensure that the system is running normally. When the auto mode is set to RET (Return) or SUP (Supply) air, the specified temperature is the temperature of the return air or supply air.

NOTE: The default auto mode of the unit is Supply Air control mode.

9.4.7 Evaporator Fan

Select Main Menu > Evap Fan and press Enter as **Figure 9.11** below, and the Evap Fan Setting values are saved.

Figure 9.11 Evaporator Fan Setting

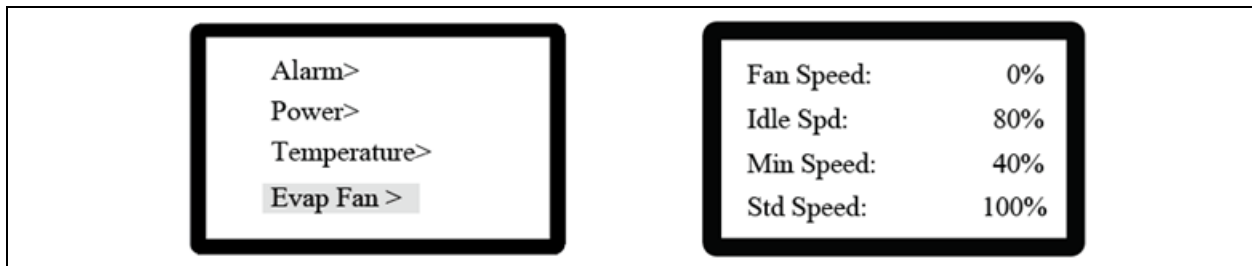

NOTE: The Evaporator Fan shows information about the evaporator fan, such as current fan speed. Idle mode speed, minimum fan speed and standard fan speed can be set.

9.4.8 Humidity

Select Main Menu > Humidity and press Enter as shown in **Figure 9.12** below. The humidity settings are saved.

Figure 9.12 Humidity

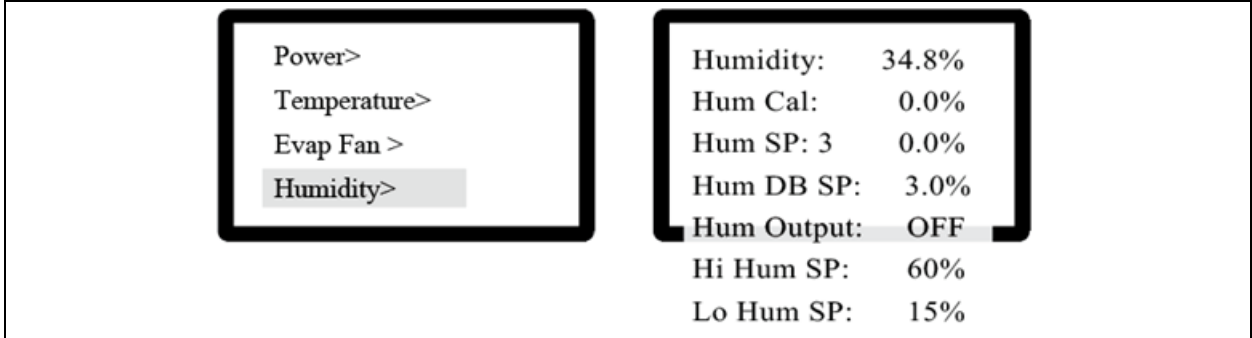

9.4.9 System Status

To access the System Status, select Main Menu > System Status, as **Figure 9.13** below.

Figure 9.13 System Status

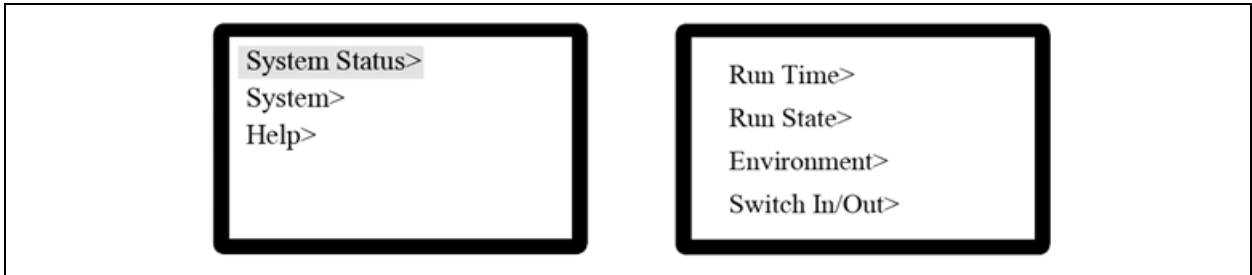

9.4.10 Run Time

The operation time of the device can be queried from the Run Time menu, as **Figure 9.14** below.

Figure 9.14 Run Time Menu

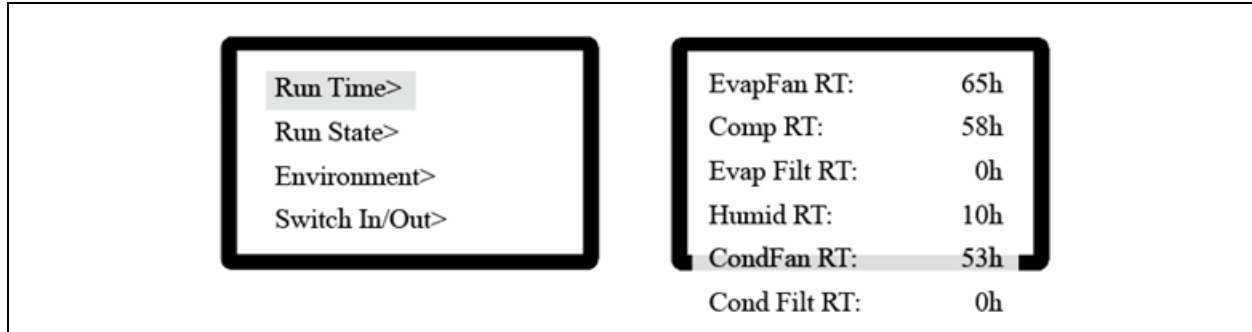

9.4.11 Run State

The Run state show the status, in real time, of some system values such as high and low pressure, compressor discharge temperature, compressor capacity and fan speed, as **Figure 9.15** below. To change values into Imperial System, go to the following path: ENT > System Set > Display > Units.

Figure 9.15 Run State Menu

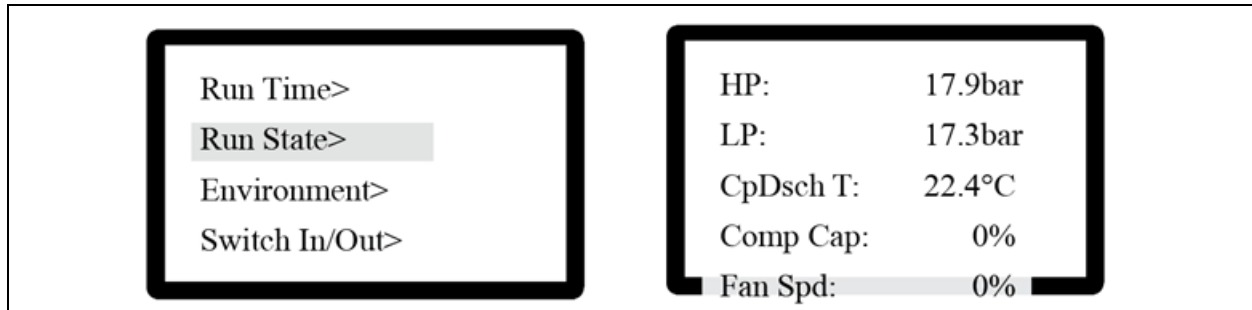

9.4.12 Environment

This section of the menu shows a number of environment variables, in real time.

Figure 9.16 Environment Menu

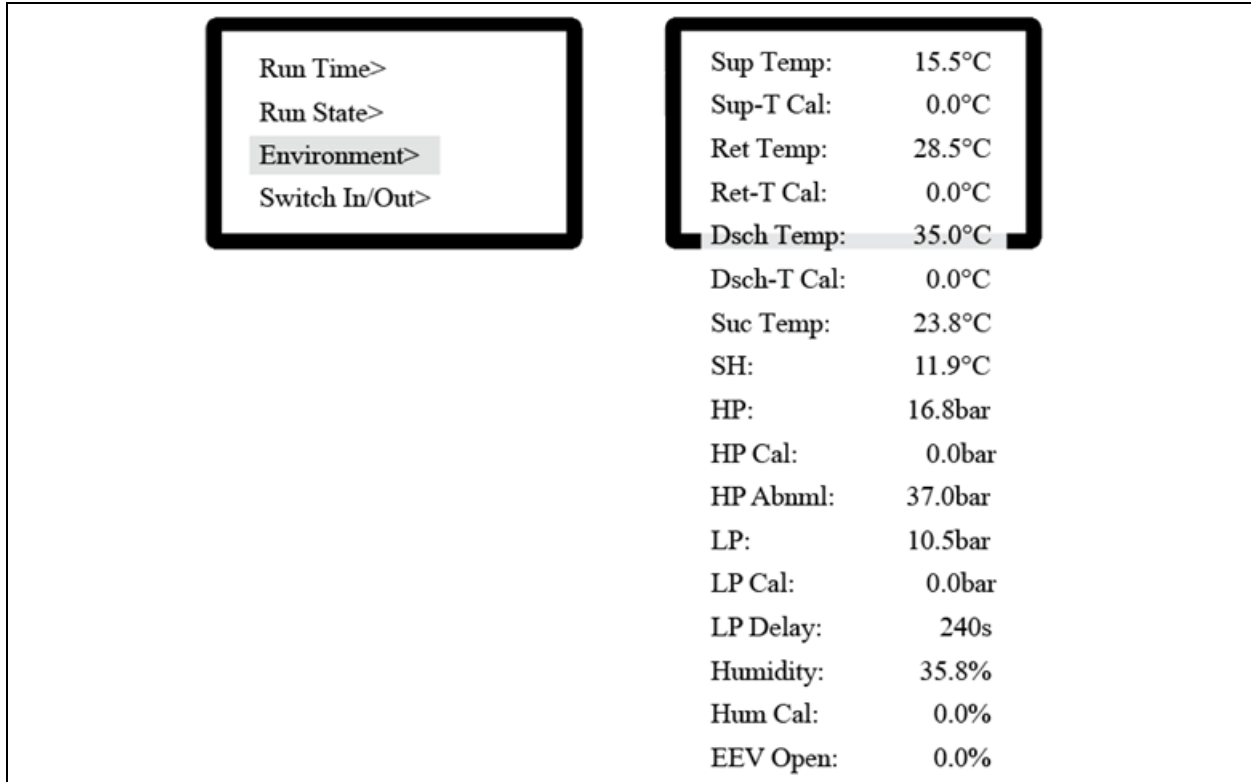

9.4.13 Switch In/Out

Select Main Menu > System Status > Switch In/Out. In this section the remote sensor, the condenser fan, the compressor, and alarms can be activated or deactivated.

Figure 9.17 Switch In/Out Menu

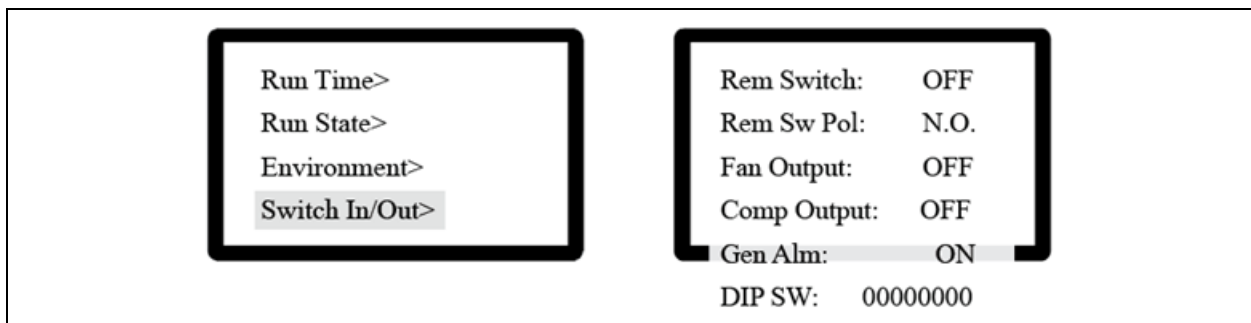

9.4.14 System Menu

System menu contains the Communication Set (Common Set) and Display sections.

Communication Set (Common Set)

In this section, you can set the directions of the Monitor Address (Mon Addr) and enable / disable the Service Information.

Figure 9.18 Common Set Menu

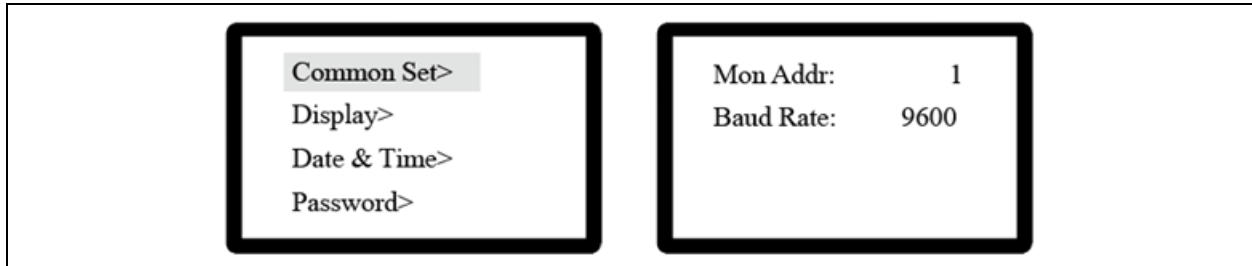

Display

The Display section allows configuration of contrast level, backlight intensity, display language, and system of units.

Figure 9.19 Display Menu

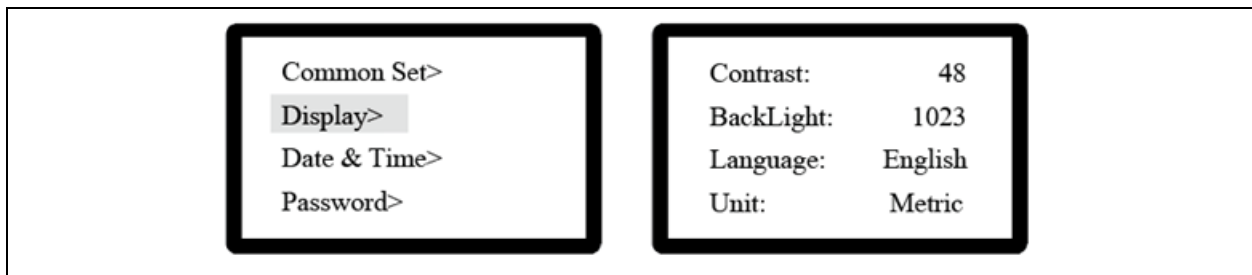

Date & Time

On the Display section it is possible to set the date in the format of Year, Month, and Day, and the time in the format of Hour, Minute, and Second.

Figure 9.20 Date & Time Menu

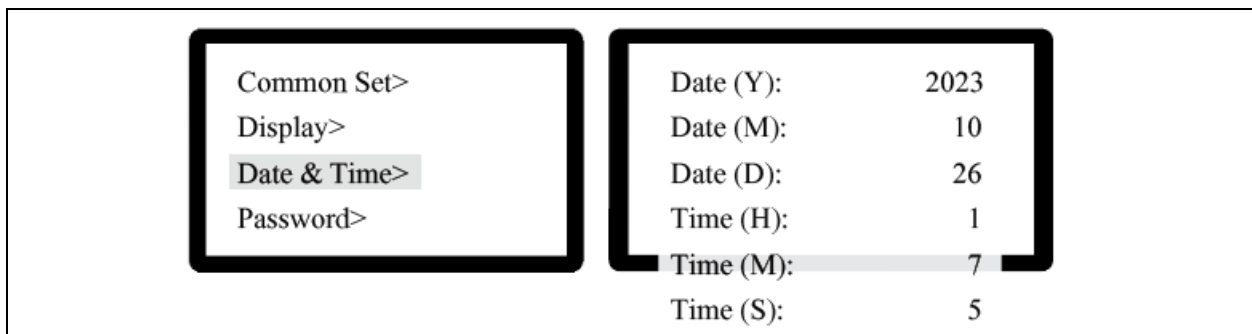

Password

The access password can be configured in the Display section as well.

Figure 9.21 Password Menu

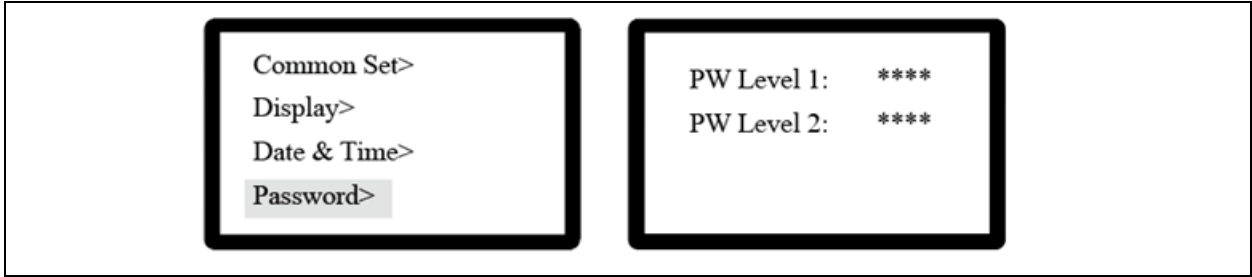

9.4.15 Help Menu

Select Main Menu > Help Menu to access the Unit version and Service, as shown in Figure 9.22 below.

Figure 9.22 Version and Service Information

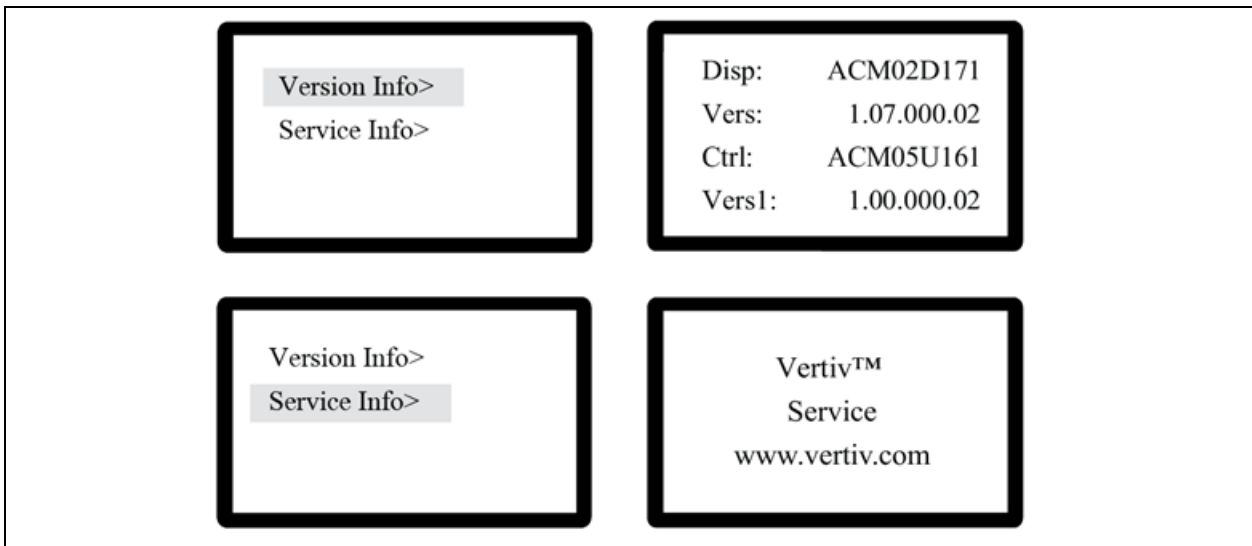

9.5 Menu Structure and Parameters (For Service Personnel)

On the Main screen, press the ESC button 5 times to enter the Service page. To access the full Service menu, enter the password 5010.

NOTE: It is not recommended for users to modify these parameters on their own; please consult qualified service personnel.

Figure 9.23 Service Page



Figure 9.24 Full Service Menu

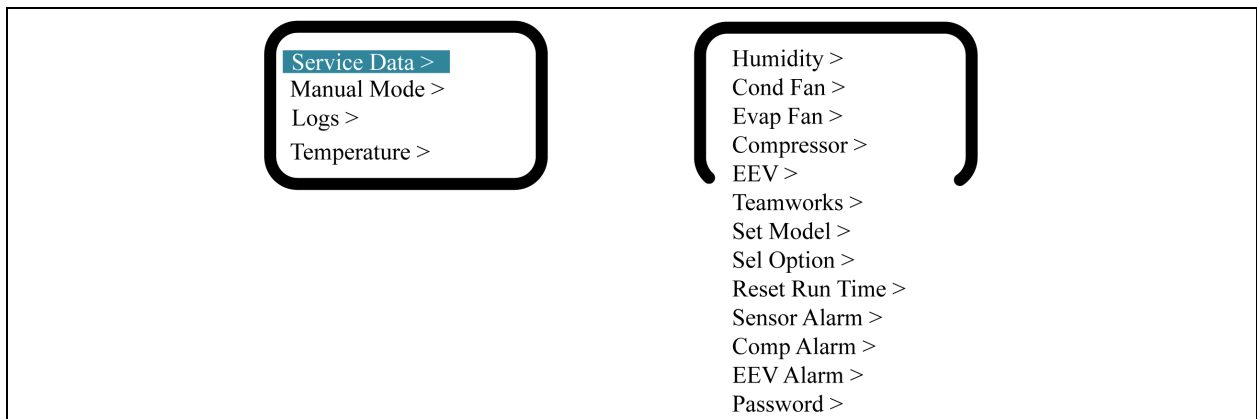

9.5.1 Service Data

The Service Data menu displays detailed unit operating information. In addition to basic parameters such as supply air temperature, return air temperature, and humidity, it also shows high and low pressures, suction and discharge temperatures, the speeds of the indoor and outdoor fans and the compressor, as well as the opening percentage of the EEV.

Figure 9.25 Service Data

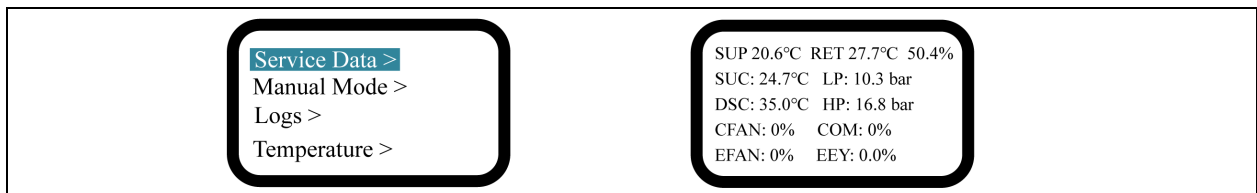

9.5.2 Manual Mode

Manual mode is primarily used for unit debugging or troubleshooting. In Manual Mode, the compressor and indoor/outdoor fans can be started manually, or the Vacuum mode can be activated. You can also set the operating status of the compressor, indoor/outdoor fans, and EEV, and adjust their outputs accordingly.

Figure 9.26 Manual Mode

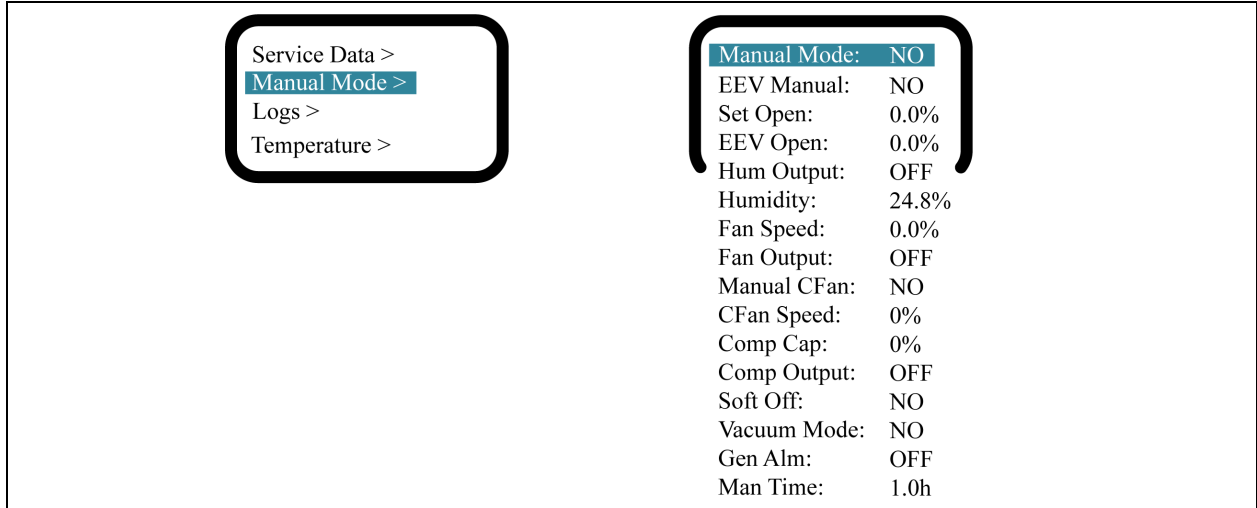

9.5.3 Logs

In the Logs menu, you can view the start and end times of historical alarm records, including high-pressure abnormal alarms.

Figure 9.27 Logs

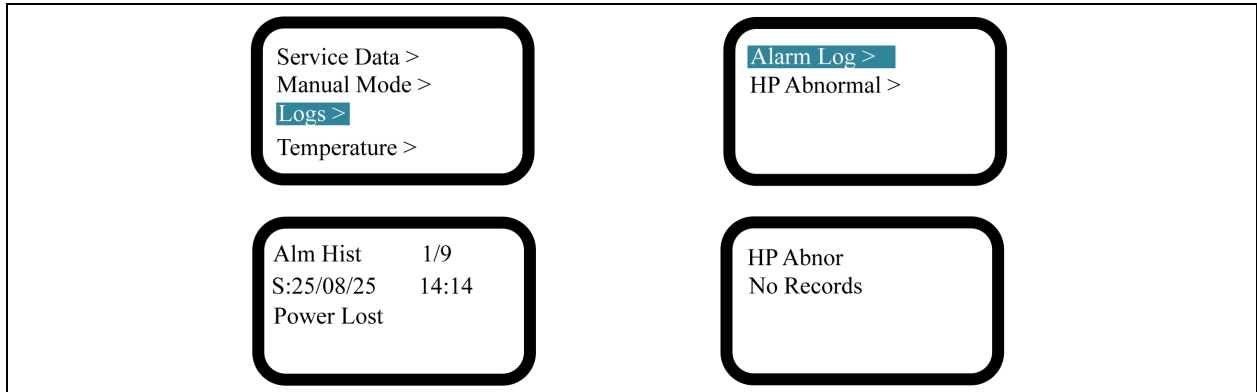

9.5.4 Temperature

This page is the same as the temperature menu in the user menu. For details, see [Menu Structure](#) on page 131.

9.5.5 Humidity

This page is the same as the Humidity menu in the user menu. For details, see [Menu Structure](#) on page 131.

9.5.6 Condenser Fan

In the Cond Fan (condenser fan) menu, you can check the operating status of the condenser fan, set its operating parameters, and switch its operating mode between normal mode and night mode.

Figure 9.28 Condenser Fan

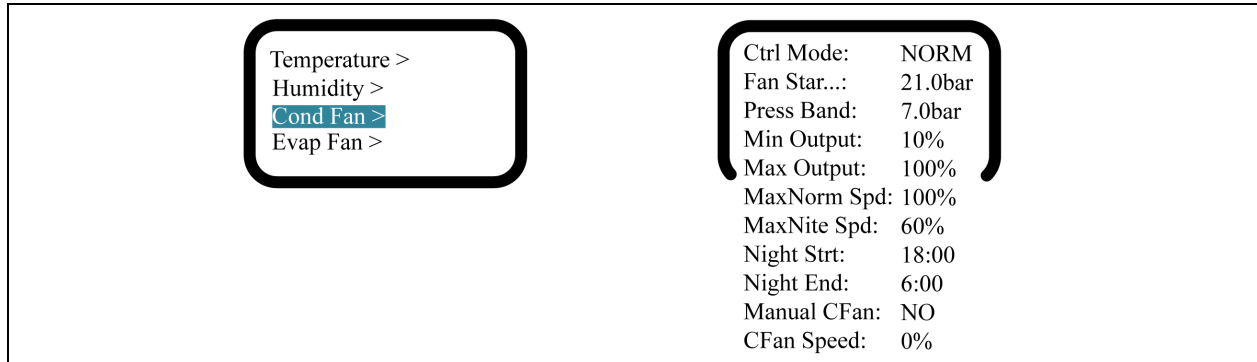

9.5.7 Evaporator Fan

In the Evap Fan (evaporator fan) menu, you can check the operating status of the evaporator fan and set parameters such as fan speed, voltage, delay, and step size.

Figure 9.29 Evaporator Fan

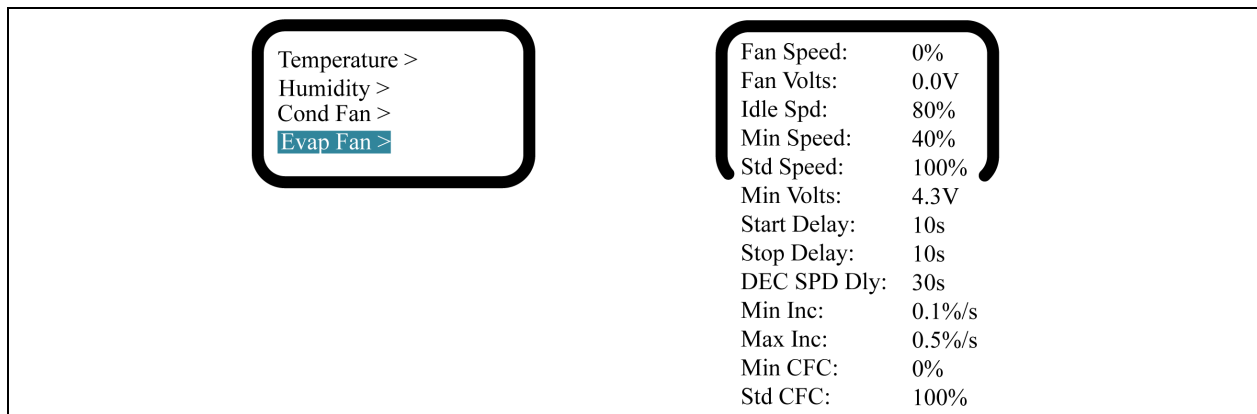

9.5.8 Compressor

In the Compressor menu, you can check the operating status of the compressor and set parameters such as compressor capacity, CFC, and others.

Figure 9.30 Compressor

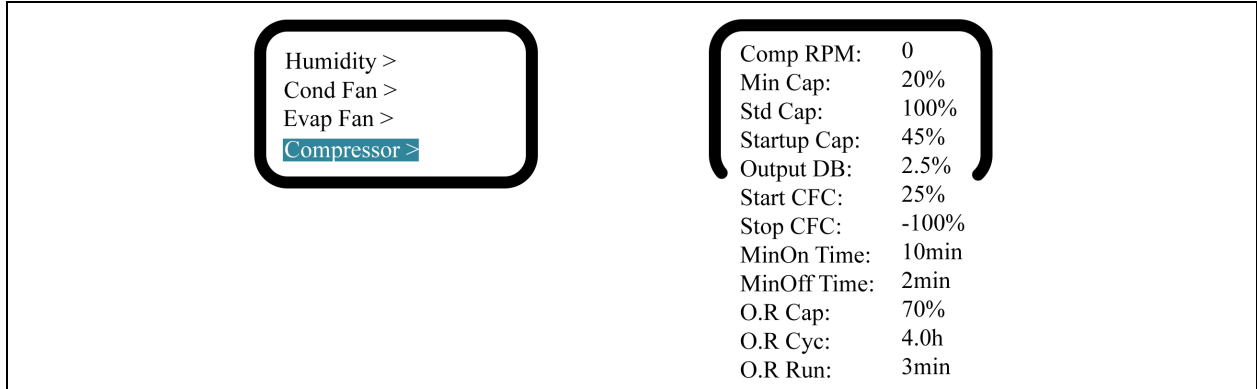

9.5.9 EEV

In the EEV menu, you can check the operating status of the EEV and set parameters such as the valve opening.

Figure 9.31 EEV

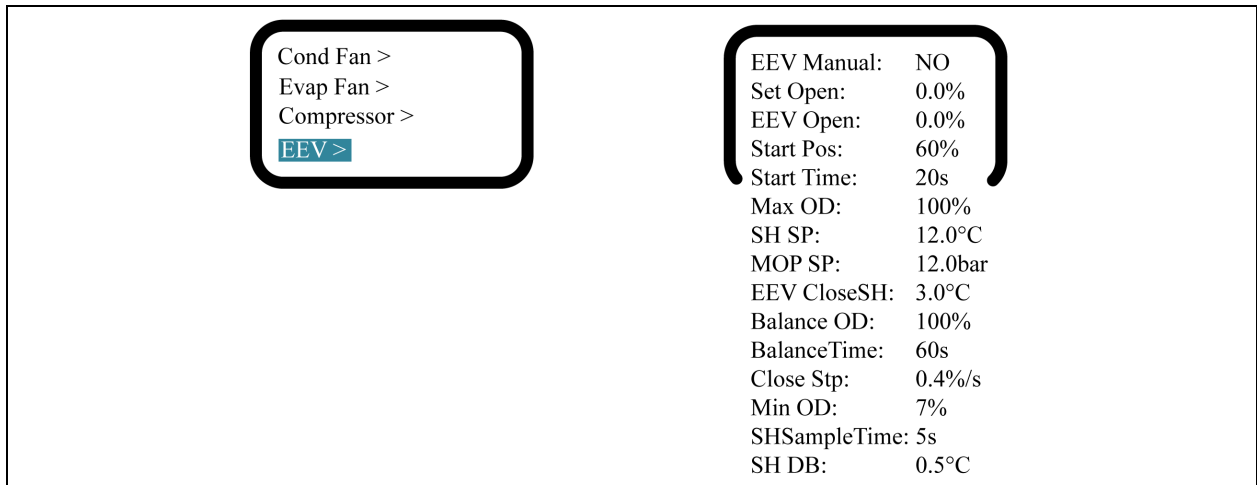

9.5.10 Teamwork Set

To configure teamwork control, select Service > Teamwork Settings.

Teamwork Mode Levels

- Teamwork 0: Standby and rotation control.
- Teamwork 1: Standby, rotation, and cooling/heating cascade control.
- Teamwork 2: Standby, rotation, and anti-conflict (avoid fighting) control.
- Teamwork 3: Standby, rotation, and fan cascade control.

Standby Function

One or more units can be designated as standby units. These units run their fans at a default speed. If a critical or normal alarm occurs on the master unit, a standby unit will automatically activate.

Critical Fault Alarms

Critical fault alarms include: High pressure lock, low pressure lock, high discharge temperature lock, low discharge superheat lock, low pressure sensor failure lock, compressor drive failure lock, fan failure (considered a critical alarm when the unit is set to shut down on this fault), high water level (considered a critical alarm when the unit is set to shut down on this fault), and power failure.

Normal Alarms

Normal alarms include: High discharge temperature, airflow temperature sensor failure, discharge temperature sensor failure, suction temperature sensor failure, low pressure sensor failure, high pressure sensor failure, EEV drive communication failure, compressor drive communication failure, compressor temperature control sensor failure, fan temperature control sensor failure, high supply temperature, high return temperature, and high remote temperature.

Rotation

The rotation function ensures equal runtime distribution across all units.

Anti-Conflict Function (Avoid Fighting)

The anti-conflict function prevents units from performing opposing operations, such as cooling vs. heating or humidifying vs. dehumidifying. The master unit calculates the number of active units in each mode. If the number of cooling (or humidifying) units exceeds the number of heating (or dehumidifying) units, the latter will stop.

Cascade Function

If an alarm occurs on the master unit, a standby unit will activate.

Figure 9.32 Team Work

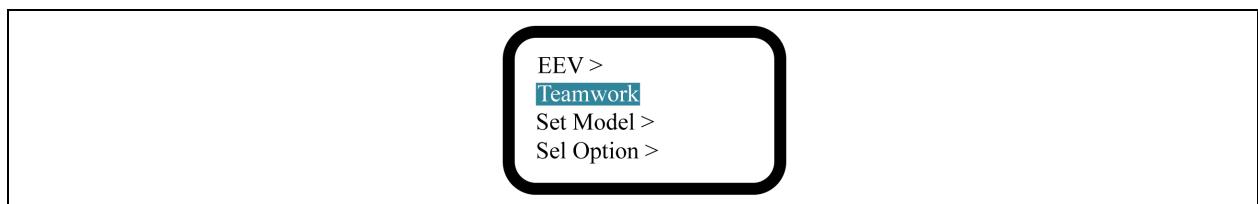

Figure 9.33 Parameter

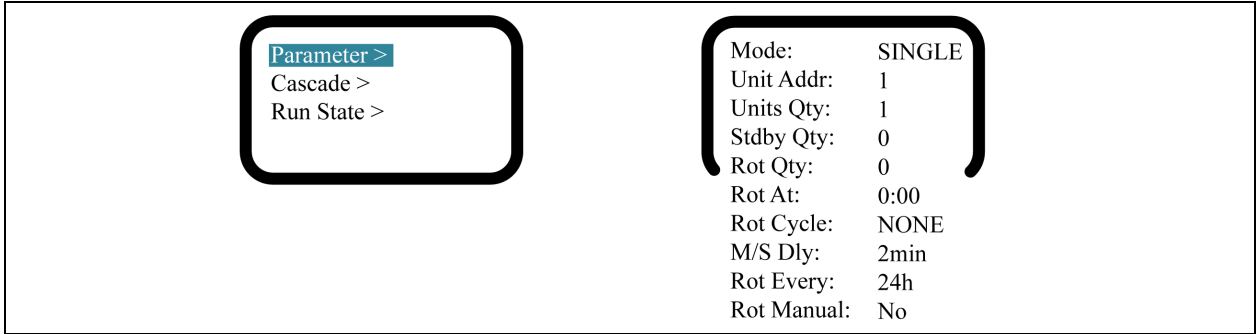

Figure 9.34 Cascade

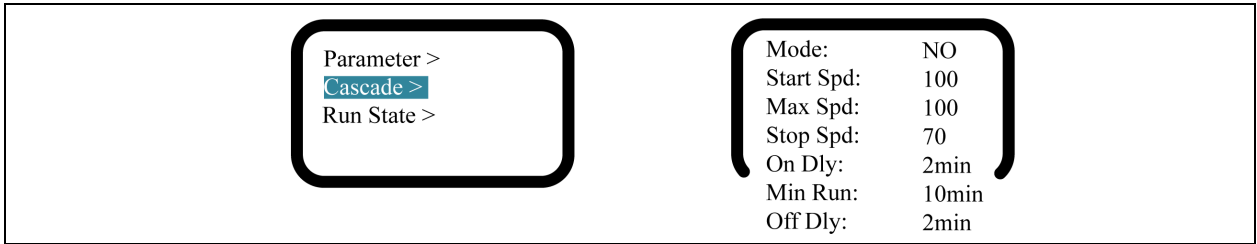
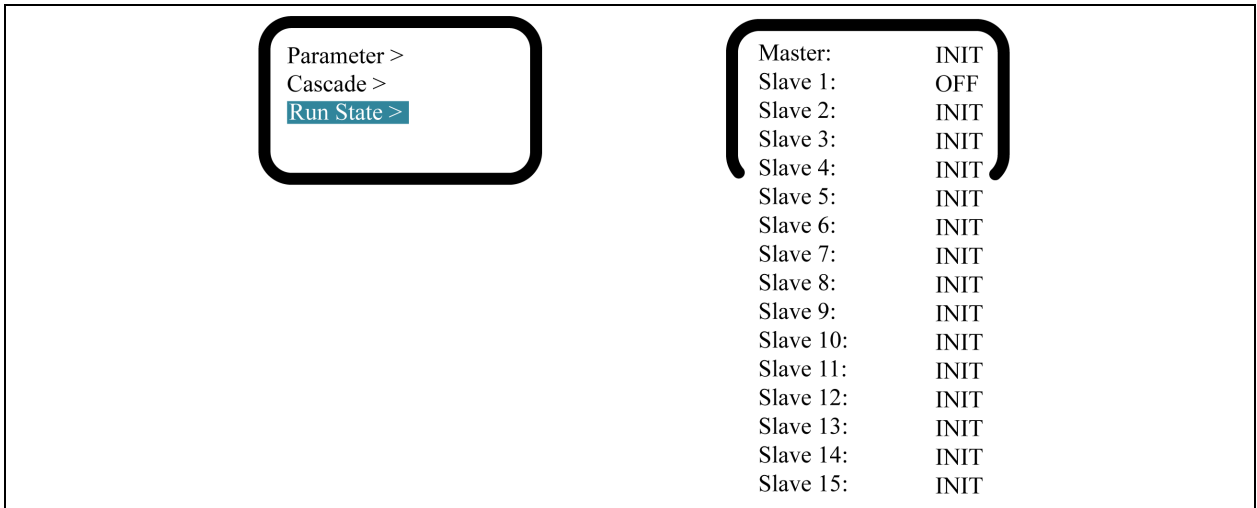

Figure 9.35 Run State



9.5.11 Model

In the Model menu, you can select the unit model.

NOTE: When the PACC control board is replaced, the parameters must be reset and the unit model reselected.

Figure 9.36 Model



9.5.12 Select Option

In the Sel Option (select option) menu, you can restore default parameters, clear historical alarms, clear locked alarms, and enable dew point control mode. You can also define how the unit should operate after certain special alarms are triggered.

Figure 9.37 Select Option

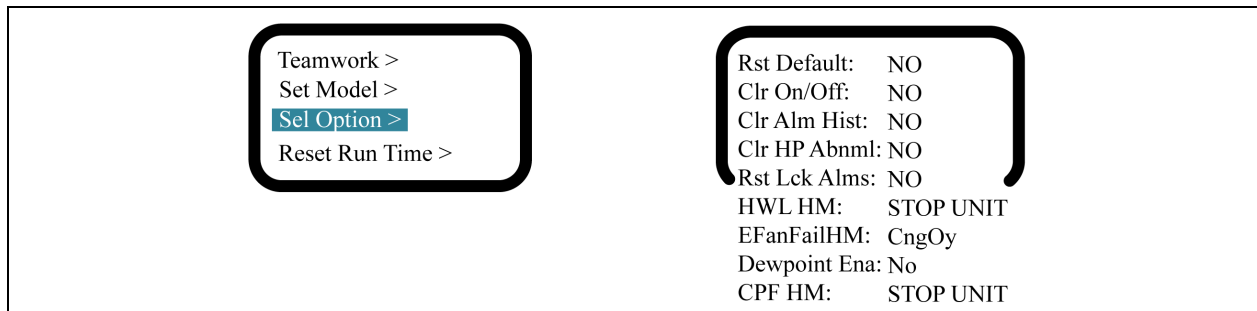

9.5.13 Reset Run Time

In the Reset Run Time menu, you can reset the operating hours of the compressor, evaporator and condenser fans, humidifier (if equipped), and air filter to zero.

Figure 9.38 Reset Run Time

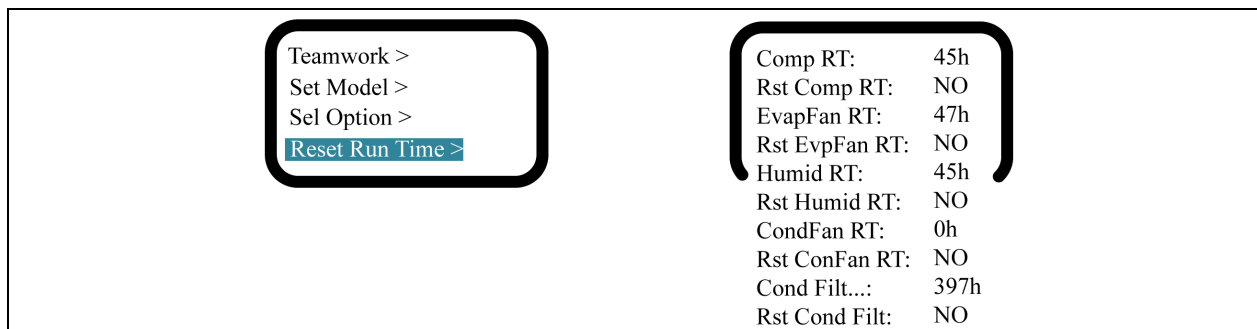

9.5.14 Sensor Alarm

In the Sensor Alarm Set menu, you can configure the attributes of sensor-related alarms. The available attributes are Enable (EN), Message (MSG), and Disable (DIS). For certain critical alarms, only Enable (EN) and Message (MSG) can be selected.

Figure 9.39 Sensor Alarm



9.5.15 Compressor Alarm

In the Compressor Alarm Set menu, you can configure the attributes of compressor-related alarms. The available attributes are Enable (EN), Message (MSG), and Disable (DIS). For certain critical alarms, only Enable (EN) and Message (MSG) can be selected.

Figure 9.40 Compressor Alarm

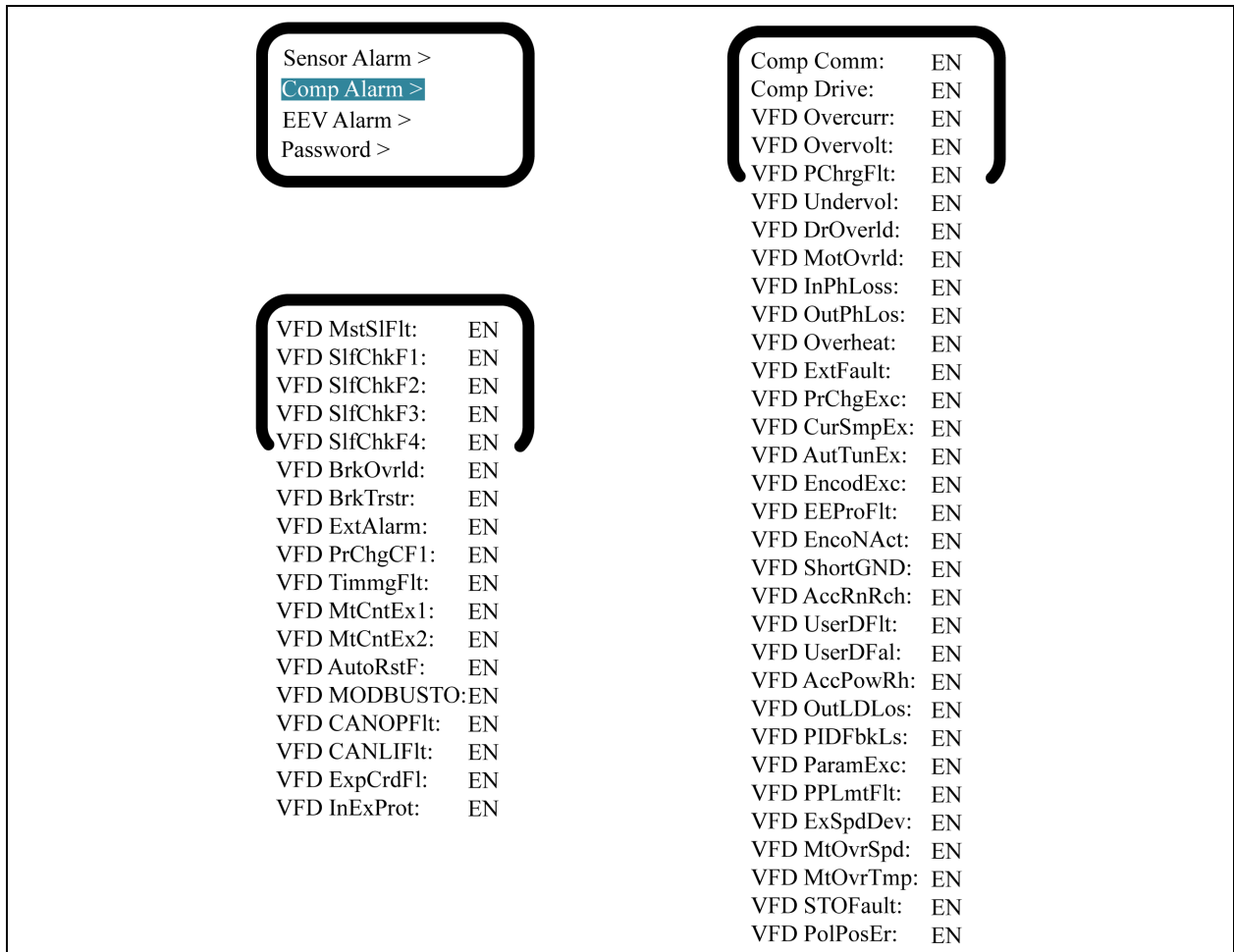

9.5.16 EEV Alarm

In the EEV Alarm Set menu, you can configure the attributes of EEV-related alarms. The available attributes are Enable (EN), Message (MSG), and Disable (DIS). For certain critical alarms, only Enable (EN) and Message (MSG) can be selected.

Figure 9.41 EEV Alarm



9.5.17 Password

In the Password Set menu, you can change the Level 1 and Level 2 passwords.

Figure 9.42 Password



This page intentionally left blank

10 Operation

10.1 Automatic Unit Restart

When the unit is on state, if the power supply is powered off and on, the unit will automatically restart.

10.2 Standard Operation

10.2.1 Auto Mode

Press the ON/OFF button for 3 seconds to start the automatic system.

Auto mode operation will follow the control mode and target temperature.

When operating in auto mode, says S/D-ON, when system is shut down, it says S/D-OFF.

10.3 Refrigerant Detection System Operation

Please refer to [Refrigerant Leak Detection System](#) on page 6 at the beginning of this manual.

This page intentionally left blank

11 Maintenance

NOTICE

All maintenance operations must be conducted strictly observing the National and Local accident prevention regulations, especially the accident prevention regulations concerning electrical systems, refrigerators, and manufacturing resources. Maintenance may be done to air conditioning equipment only by authorized and qualified technicians. To keep all warranties valid, the maintenance must adhere to the manufacturer's instructions. The servicing of the unit should be done only when the system is deenergized. Deenergize the unit by totally disconnecting the air conditioner. Before performing any action, verify that no power is supplied to the system.

NOTICE

Only original spare parts made by Vertiv may be used. Using third-party material can invalidate the warranty. When the spare parts must be brazed, be careful not to damage the internal parts (gaskets, seals, o-rings, etc.).

NOTE: Before starting with the maintenance of the unit, review the Important Safety Instruction chapter of this manual.

NOTICE

Risk of release of hazardous substances into the environment. Can cause environmental pollution and violation of environmental regulations.

NOTICE

When removing refrigerant from a system it is recommended good practice that all refrigerants are removed safely.

SAFETY INSTRUCTIONS

Refrigerant recovery involves flammable refrigerants and pressurized systems.

Use only approved recovery cylinders. Do not mix refrigerants. Make sure that equipment is in good condition and suitable for flammable refrigerants. Ensure that electrical components are sealed.

Use calibrated weighing scales and leak-free hoses. Check that the recovery machine operates correctly before use.

Process recovered refrigerant according to local legislation. Use the correct cylinder and prepare the waste transfer note.

Make sure that compressors and oils are fully evacuated before removal. Do not use open flames or ignition sources to heat the compressor. Drain oil safely.

For detailed procedures, refer to [Recovery](#) on page 13.

NOTICE

Every working procedure that affects safety must be conducted by competent person.

11.1 Maintenance Schedule

After installation, the following checks shall be applied to installations:

- The actual refrigerant charge is in accordance with the room size within which the refrigerant containing parts are installed.
- The ventilation machinery and outlets are operating adequately and are not obstructed.
- Marking to the equipment continues to be visible and legible. Markings and signs that are illegible shall be corrected.
- Refrigerating pipe or components are installed in a position where they are unlikely to be exposed to any substance which may corrode refrigerant containing components, unless the components are constructed of materials which are inherently resistant to being corroded or are suitably protected against being so corroded.

Conduct monthly, quarterly, biannual, and annual checks according to the following guidelines.

Table 11.1 Maintenance Schedule Check List

Component Check Items		Maintenance Period			
		Monthly by User	3 Months	6 Months	1 Year
General	Check for irregular noise from unit fans	X			
Filters	Check the state of filters	X			
Fan	Verify that impellers move freely		X		
	Check bearings			X	
	Check that motor supports are fixed securely				X
Electronics	Check electrical connections are fixed				X
Refrigerant circuit	Check main refrigerant circuit pressure in normal range				X
	Check if there are any oil leaks in pipe connectors				X
	Check if there are any water leaks in drainpipe				X
	Check if the temperature are in normal range				X

11.2 Air Filters

The indoor unit contains 1 air filter placed inside the top cover.

Figure 11.1 Filter Location

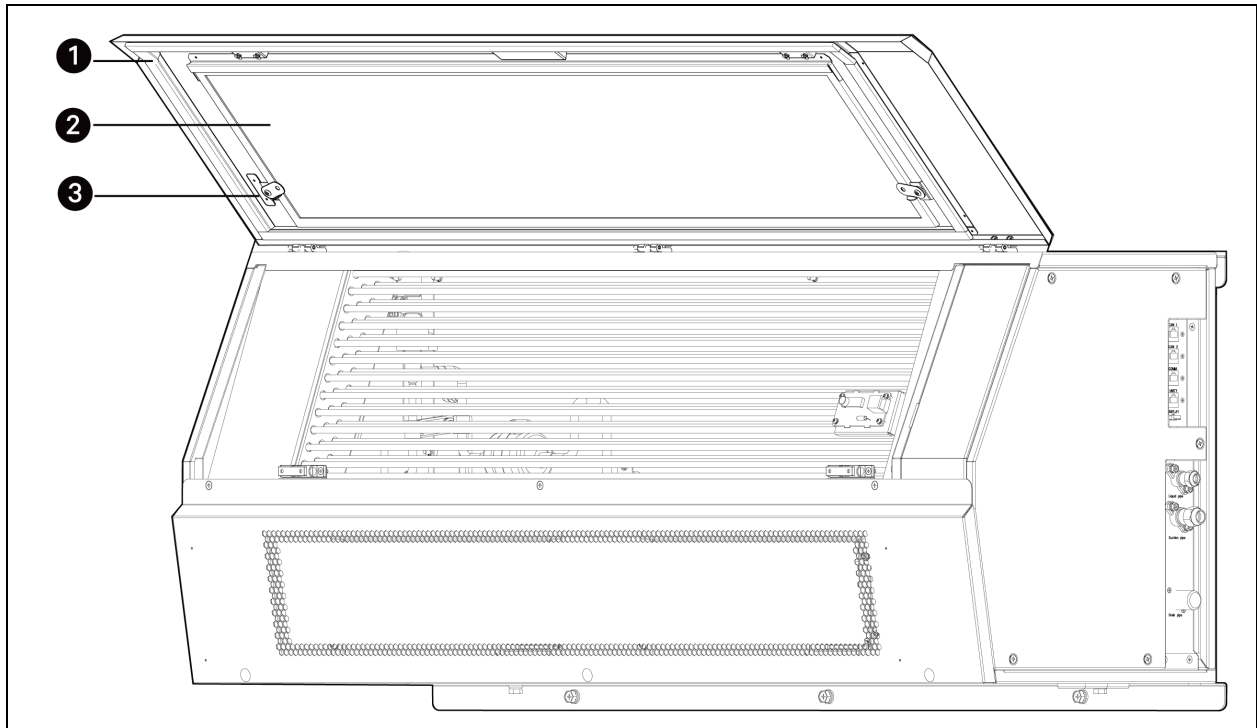

Item	Description	Item	Description
1	Top Cover	3	Rotating Latches (2 per filter)
2	Air Filter		

Cleaning the Air Filters

Clean the air filter once a month or more if necessary. Note the following guidelines:

- Bending the air filter can break it.
- If the air filter is not assembled correctly, dust and other substances can enter the indoor unit.

To remove the Air Filters

1. Turn off the power, then open the front cover (air intake panel) by holding the handle and lifting the cover completely.

NOTE: Operate from the front of the indoor unit.

2. On the filter requiring maintenance, rotate the two-piece latches located on the brackets at each end of the filter outward.
3. Extract the filter by sliding it downward and outward from the brackets and set it aside.
4. Clean the filters with a vacuum cleaner or lukewarm water with a neutral detergent.
5. Dry the filters in the shade.

Figure 11.2 Removing the Air Filter from the Unit

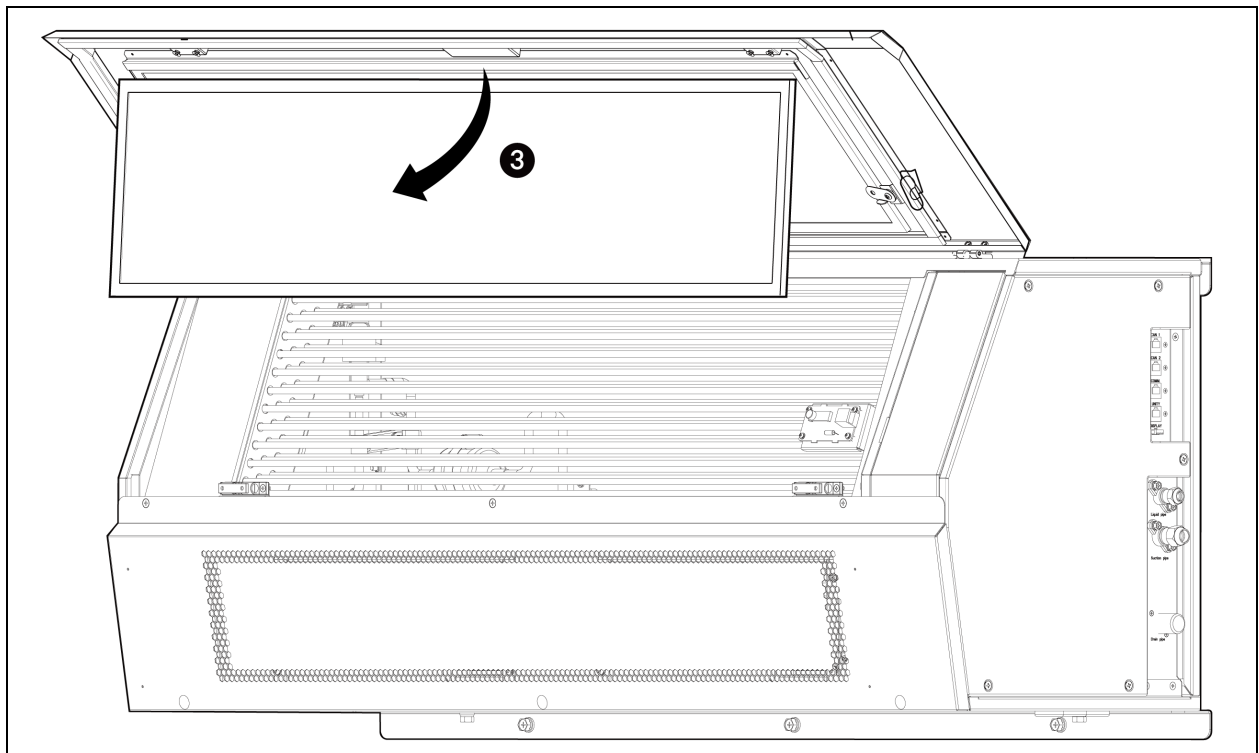
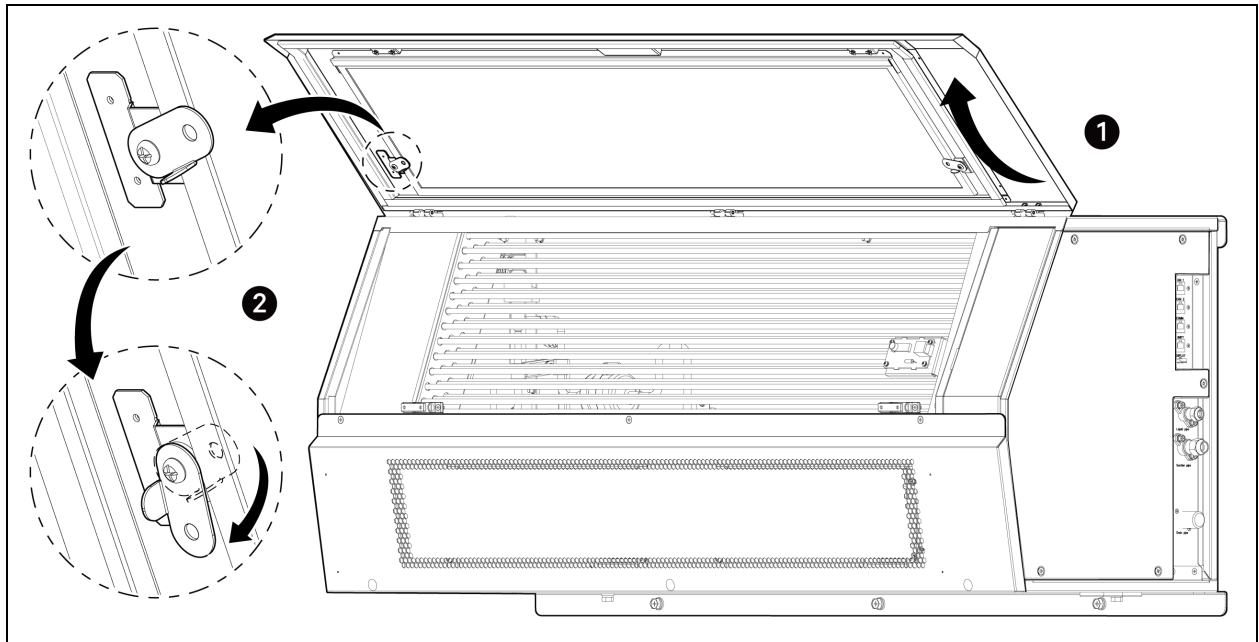

Item	Description	Item	Description
1	Lift the front cover	3	Slide the filter out of the unit
2	Rotate the filter latches to release the filter		

To put the Air Filters back

1. Slide the filter upward and inward into the brackets until properly positioned.
2. Rotate the two-piece latches on the brackets at each end of the filter inward to secure it.
3. Close the front cover (air intake panel) by lowering it fully, then restore power to the unit.

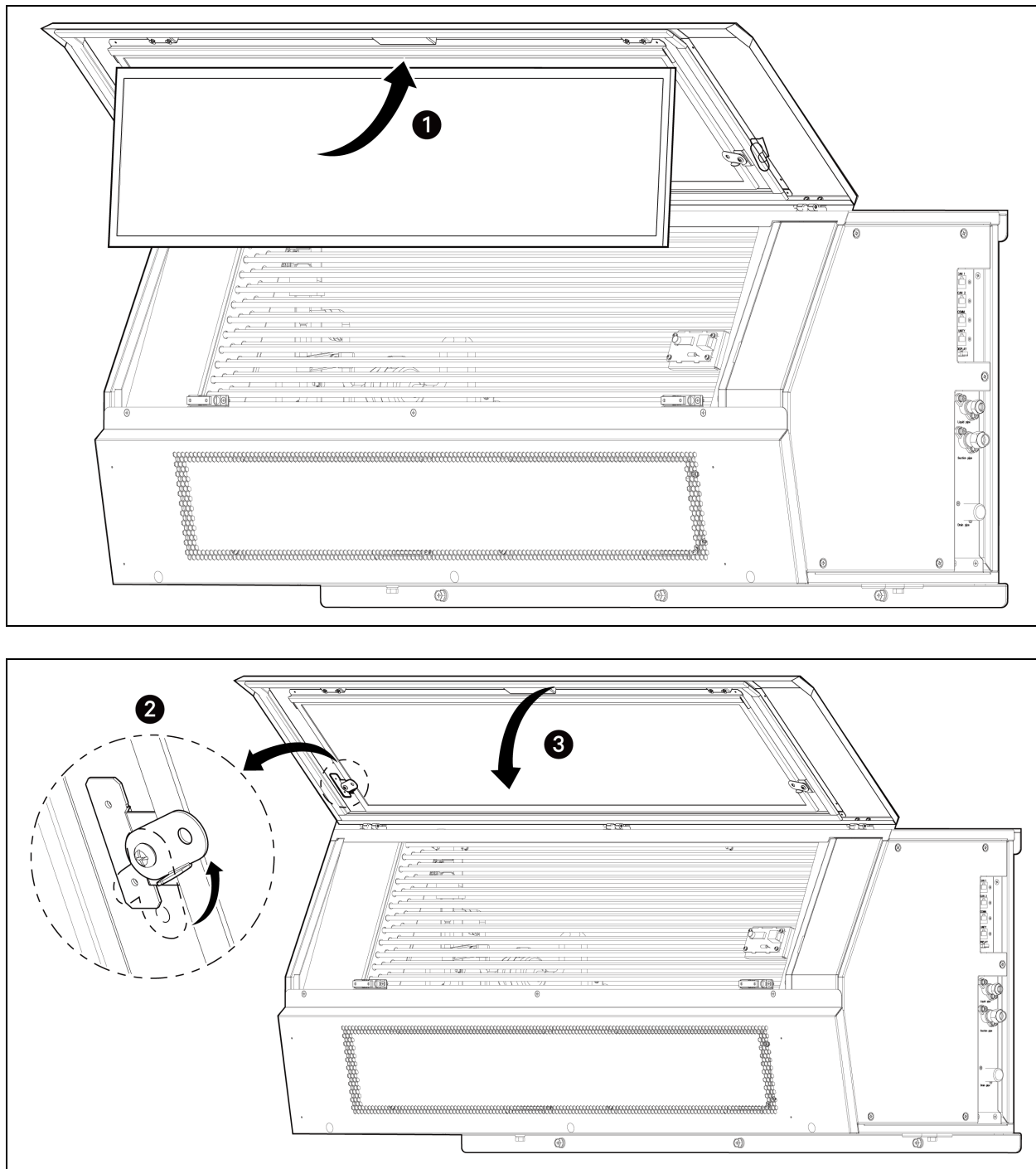
Figure 11.3 Inserting Cleaned Air Filter in the Unit

Item	Description	Item	Description
1	Slide the filter under the left bracket	3	Close the front cover
2	Rotate the latches to fix the filter		

11.3 Condensate Drain

To maintain the condensate drain, check and clear any obstructions in pipelines during routine maintenance.

11.4 Indoor Fan Maintenance



WARNING! Risk of electric shock and contact with high-speed rotating fans. Can cause injury or death. Switch off all local and remote electrical supplies, verify that power is off with a voltmeter and verify that all fans have stopped rotating before working inside the unit cabinet or disconnecting the fan power wires.

Figure 11.4 Fans Location

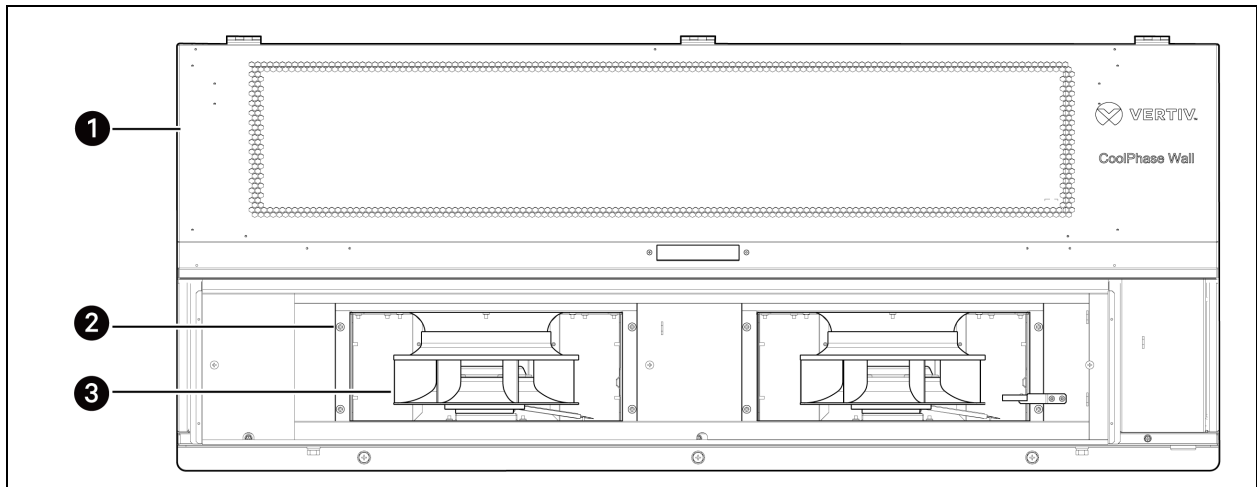

Item	Description	Item	Description
1	Indoor Unit Front View	3	Fan
2	Fan Case		

To replace the fan:

1. Shut the unit off.
2. Open the top cover.
3. Remove the M5x12 countersunk screw then the screw covers and M4x12 combination screws to remove the air outlet panel.

NOTE: The M4x12 combination screws are inside the cover.

Figure 11.5 Removing the Front Cover

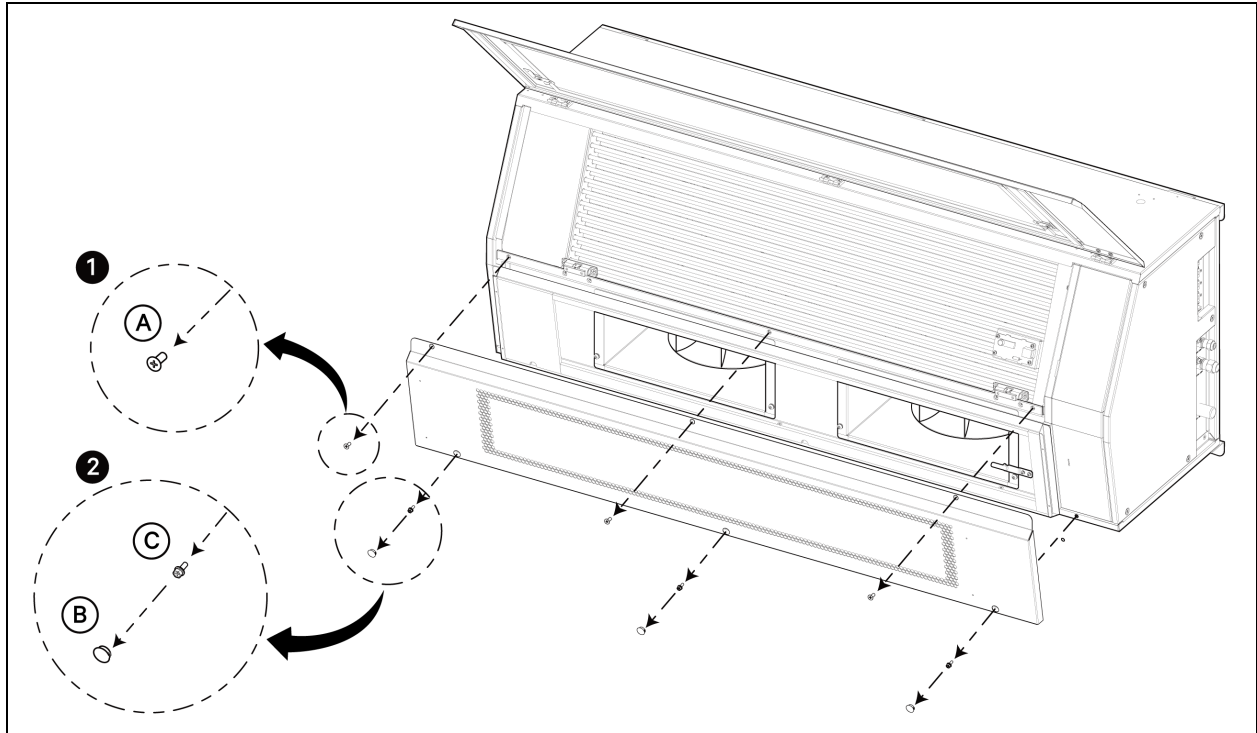

Item	Description	Item	Description
A	M5x12 Countersunk Screw	1	Remove the M5x12 countersunk screw
B	Screw Covers	2	Remove screw covers and M4x12 combination screws
C	M4x12 Combination Screws		

- Once determining the fan that needs maintenance, unplug the power and signal wire connectors of the fan and then remove the four (4) M5x12 fixing screws on the front side of the fan box. Finally, pull out the fan box.

NOTE: When removing the rightmost fan, be sure to first remove the front temperature sensor bracket.

Figure 11.6 Removing the Fan Box

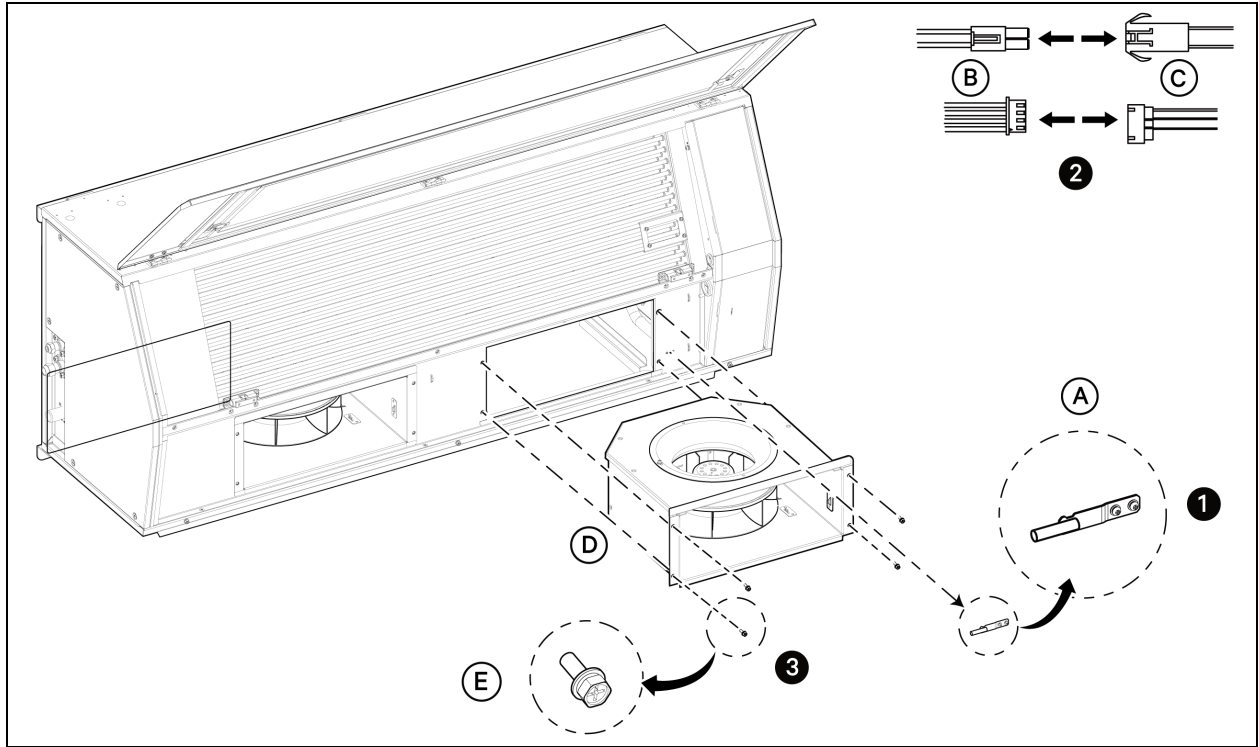

Item	Description	Item	Description
A	Temperature sensor bracket	E	M5x12 (x4)
B	Wiring from fan	1	Remove temperature sensor bracket in case of rightmost fan
C	Wiring from E-box	2	Unplug power and signal wire connectors
D	Fan box	3	Remove M5x12 fixing screws (x4)

5. Place the extracted fan box on a stable surface then remove the cable ties that hold the fan cable.

Figure 11.7 Removing the Cable Ties

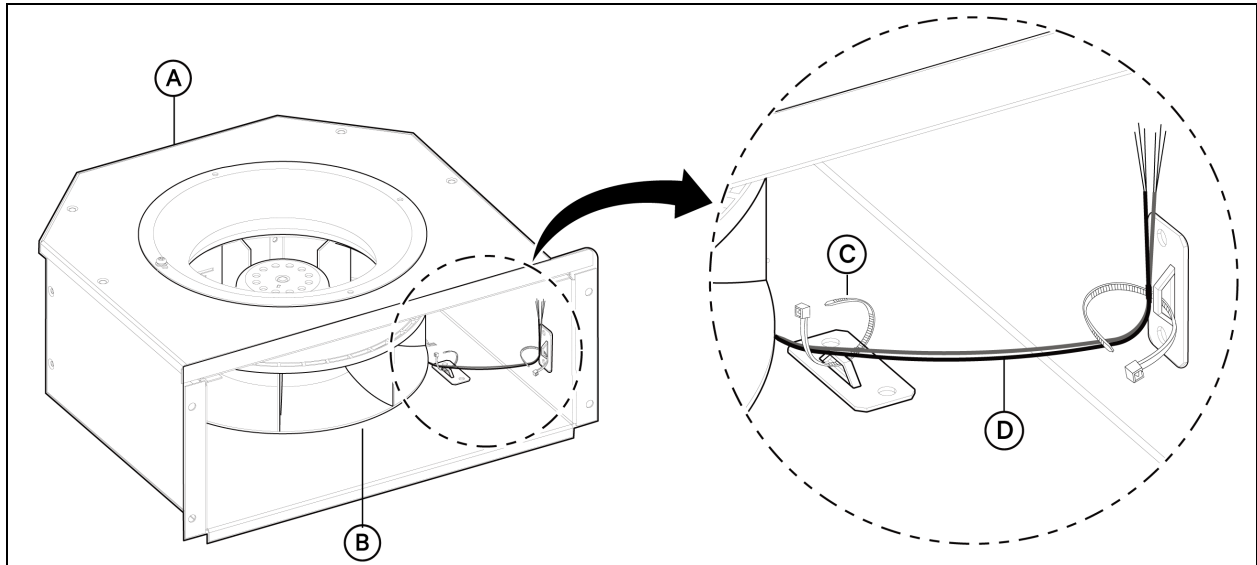

Item	Description	Item	Description
A	Fan Box	C	Nylon Ties
B	Fan	D	Cables

- Remove the four (4) M4x12 combination screws on the top of the fan box to remove the fan guide ring.

Figure 11.8 Removing the Fan Guide Ring

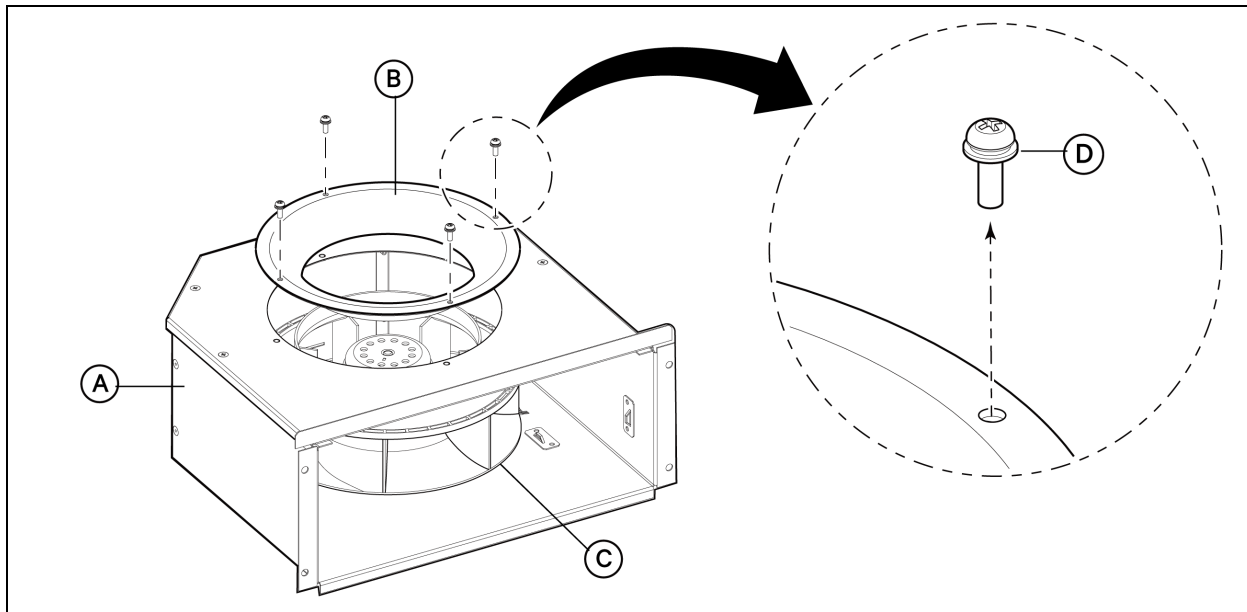

Item	Description	Item	Description
A	Fan Box	C	Fan
B	Fan Guide Ring	D	M4x12 Combination Screws

7. Remove the four (4) M4x8 countersunk screws at the bottom of the fan box, take out the fan and the fan support. Next, remove the four (4) M4x8 combination screws at the bottom of the fan support, and then, release the fan from the support.

Figure 11.9 Take Out Fan and Support

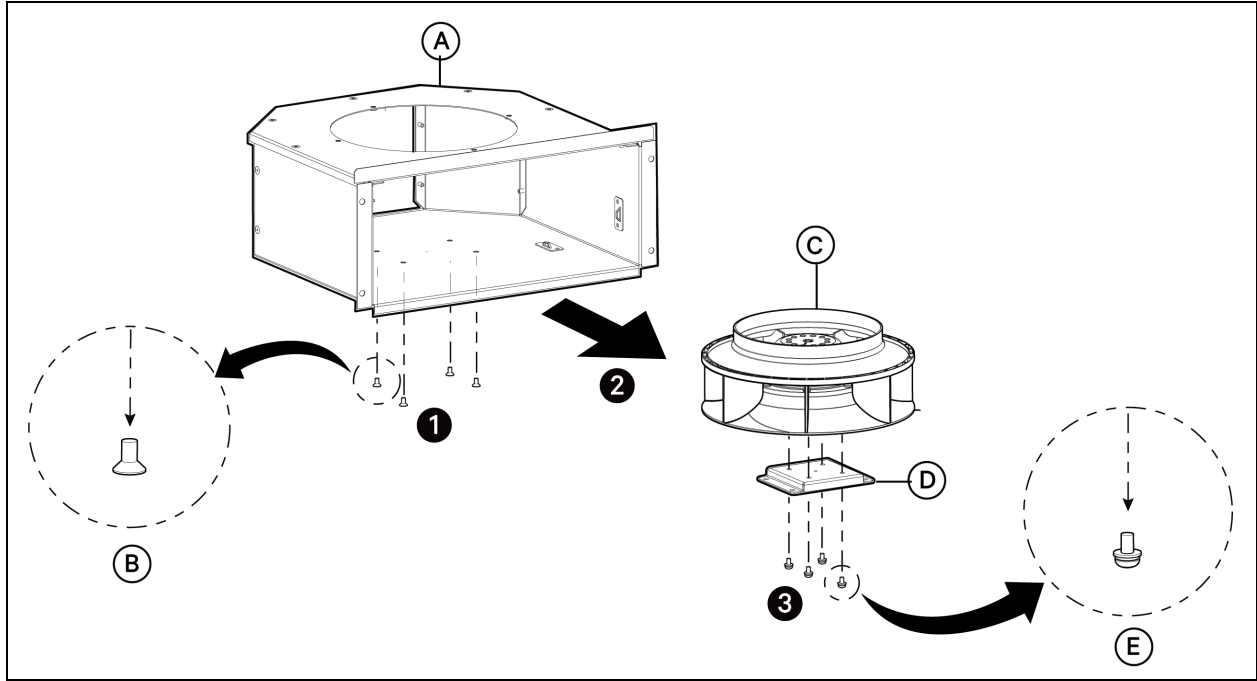

Item	Description	Item	Description
A	Fan box	E	M4x8 combination screws
B	M4x8 countersunk screws	1	Remove M4x8 countersunk screws
C	Fan	2	Take out fan and support
D	Fan support	3	Remove M4x8 combination screws

8. After completing maintenance, reinstall the fan by following the installation steps in reverse.

NOTE: Make sure that the fan cable is close to the cable tie plate.
Rotate the fan to ensure that the fan does not interfere with the cable.
Install the fan first, and then install the air guide ring.
Check that there is no rotation interference between the fan and the air deflector ring.

Figure 11.10 Release Fan Cable

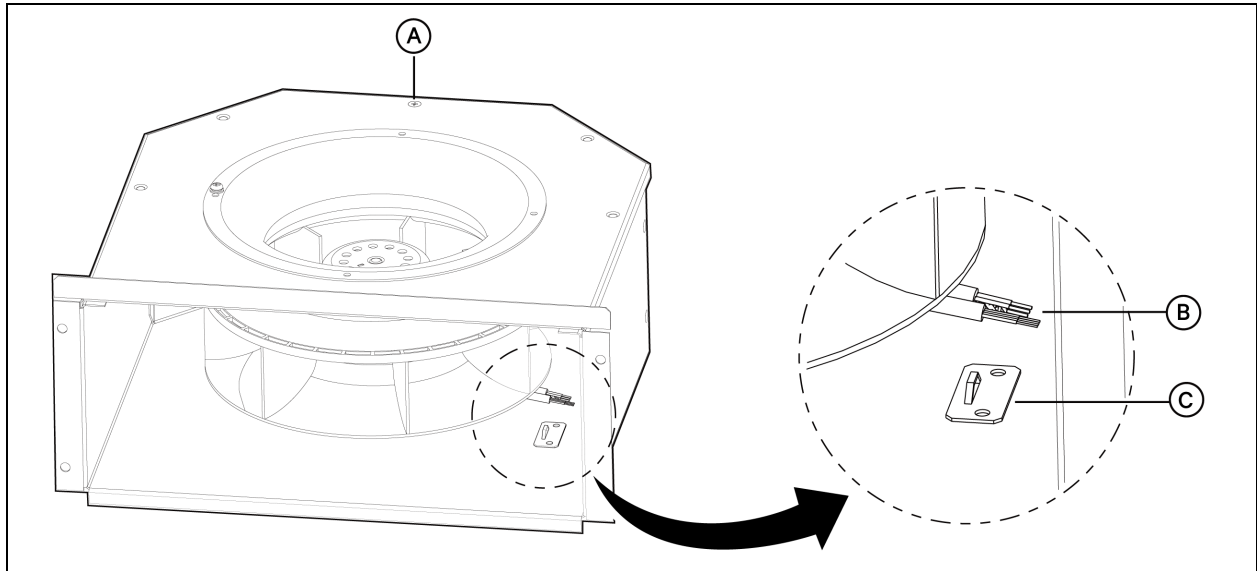

Item	Description	Item	Description
A	Fan box	C	Cable tie plate
B	Fan cable		

11.5 Cleaning the Unit

NOTICE

Risk of oil contamination with water can cause equipment damage. The evaporator requires the use of FW68S oil. Because water is the enemy of a reliable refrigeration system, extreme care must be used when opening systems during installation or service. Even though FW68S oil absorbs water at a much slower rate when exposed to air than previously used oils, if water is absorbed into the FW68S oil, it will not be easily removed. It will not be removed through the normal evacuation process. If the oil is too wet, it may require an oil change and a deep vacuum to remove moisture. FW68S oils also have a property that makes them function as a solvent in a refrigeration system. Maintaining system cleanliness is extremely important because the oil will tend to bring any foreign matter back to the compressor.

NOTICE

Only qualified personnel must perform the refrigerant cleaning.

12 Troubleshooting

12.1 Self-diagnosis at the Indoor Unit

The Vertiv™ CoolPhase Wall has a built-in self-diagnosis function. If an error occurs, an alarm will show on the HMI screen. If this occurs, contact your dealer or Vertiv technical support.

12.2 Before Calling for Service

Please check **Table 12.1** below before contacting service. If the problem persists after corrective action, contact Vertiv technical support from our website: <https://www.vertiv.com/support/>.

Table 12.1 Self Service Troubleshooting

Problem	Possible Causes	Corrective Action
The unit does not work normally.	Burning smell and strange sounds are coming from the unit.	Turn-off the unit, unplug the power cable or disconnect the power supply, and contact service.
	Water leaks from the indoor unit even when humidity level is low.	
	The power cable is damaged, or it is generating excessive heat.	
	A switch, circuit breaker (safety, ground), or a fuse is not operating properly.	
	The unit generates an error code from self-diagnosis.	
	Incorrect cabling.	Check the cable connections.
The unit does not work.	The unit is unplugged.	Check to see if the power cord is plugged into the outlet or if the power isolators are switched on.
	A fuse exploded or the power supply is blocked.	Replace the fuse or check to see if the circuit breaker is tripped.
	Voltage is too high or too low.	Turn off the unit when a power failure occurs. When the power is restored, wait 3 minutes before turning on the unit.
Unit does not emit cool air	Air is not circulating properly.	Make sure that there are not curtains, blinds, or furniture blocking the front of the unit.
	The air filter is dirty.	Clean the air filter once a month.
	The room temperature is too high.	In summer, cooling the indoor air fully may take some time.
	Cold air is escaping from the room.	Make sure that no cold air is escaping through ventilation points in the room.
	The desired temperature is higher than the set temperature.	Set the desired temperature to a level lower than the current temperature.
	There is a heating source nearby.	Avoid using heat generators like electric ovens or gas burners while the unit is operating.
	Manual Mode is selected.	During manual mode, it is possible to activate the fans so the air blows from the unit without cooling. Switch the operation mode to Auto

Table 12.1 Self Service Troubleshooting (continued)

Problem	Possible Causes	Corrective Action
	Outside temperature is too high.	The cooling effect may not be sufficient.
The fan speed cannot be adjusted.	The Auto Operation Mode is selected.	In some operation modes, you cannot adjust the fan speed. Select an operation mode in which you can adjust the fan speed.
The temperature cannot be adjusted.	The Auto Operation Mode is selected.	In some operation modes, you cannot adjust the temperature. Select an operation mode in which you can adjust the temperature.
The unit stops during operation.	The unit is suddenly turned off.	Check electrical power connections, there might be a loose or wrongly connected cable.
	A power failure has occurred during operation.	Wait for the power to come back, your unit will resume in its last operation mode several minutes after power is restored.
Water leaks from the indoor unit.	In heating operation, condensed water drops from the heat exchanger.	This requires installing a drain hose under the base pan. Contact the installer.
There is a noise or vibration.	A clicking sound can be heard when the unit starts or stops due to movements of the valves. Creaking sound: The plastic parts of the indoor unit creak due to sudden temperature changes. Flowing or Blowing sound: This is the flow of the refrigerant through the unit.	These are normal occurrences. The noise will stop.
The indoor unit gives off an odor.	Odors (such as cigarette smoke) may be absorbed into the indoor unit and discharged with air flow.	If the smell does not disappear, wash the air filter. If this does not work, contact service to clean the heat exchanger.

12.3 Self-diagnosis at the LCD Display

If the unit has a problem, it will self-diagnose and display the correspondent alarm note. Refer to **Table 12.2** on the facing page.

NOTE: Verify the LCD display function settings after recovery from an error. The settings could have changed because of communication with the controller in group mode.

Figure 12.1 Example of an Error Alarm Displayed at the LCD Display

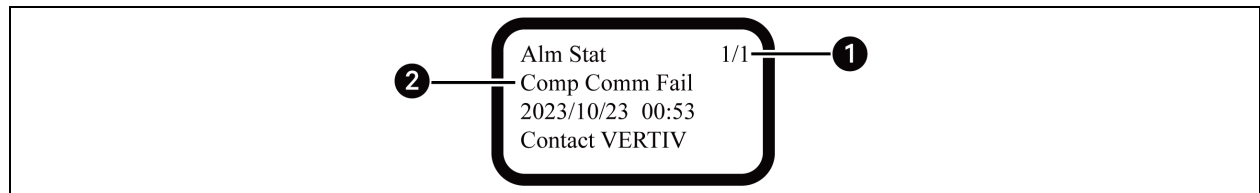

Item	Item	Description
1	Alarm Status	X / Y values = X shows which alarm is positioned at and Y shows the total quantity of alarms
2	Alarm Name	Shows the alarm

12.4 Troubleshooting Alarms Displayed at the Indoor Units

Table 12.2 below lists the most common error alarms that you will see on these units. Please contact Service if a power-down/reboot does not correct the issue. Do not attempt to fix the unit yourself.

The error alarms indicate two different types: Functional Range Alarms and Failures Alarms, assist in self-diagnosis, and helps track frequency of occurrence. **Figure 12.1** on the previous page, shows where error alarms display.

If two or more errors occur simultaneously, the lower number displays first. When an error is resolved, the number no longer displays.

Table 12.2 Vertiv™ CoolPhase Wall Failure Alarms List

Item	Alarm	Description
1	Comp Comm	Compressor Communication
2	Comp Drive	Compressor Drive
3	Comp Lock	Compressor Lock
4	CompShortCyc	Compressor Short Cycle
5	Cond Filter	Condenser Filter Maintenance
6	CondPumpFail	Condenser Pump Failure
7	Dsch Temp	Discharge Temperature
8	EEV BatFault	EEV Battery Fault
9	EEV Comm	EEV Comm Failure (Electronic Expansion Valve Communication Failure)
10	EEV DevFault	EEV Device Fault
11	EEV ParaErr	EEV Parameter Error (Electronic Expansion Valve Parameter Error)
12	EFan Fail	Evaporator Fan Failure
13	Evap Filter	Evaporator Filter Maintenance
14	Filt Maint	Filter Maintenance
14	Freq Offset	Frequency Offset
15	Hi Dsch Lock	Discharge Temp High Lock
16	Hi Dsch Temp	Discharge Temperature High
17	Hi Ret Temp	Return Temperature High
18	Hi Sup Temp	Supply Temperature High
19	Hi Water Lvl	High Water Level
20	HP	High Pressure Exist
21	HP Lock	High Pressure Lock
22	HP Sensor	High Pressure Sensor Failure
23	HP Sw Alarm	High Pressure Switch Alarm
24	HP Sw Lock	High Pressure Switch Lock
25	Lo Ret Temp	Return Temperature Low

Table 12.2 Vertiv™ CoolPhase Wall Failure Alarms List (continued)

Item	Alarm	Description
26	Lo Sup Temp	Supply Temperature Low
27	LoDschSHLock	Discharge Temp Low Lock
28	LoDschSHTemp	Discharge Temperature Low
29	LP	Low Pressure Exist
30	LP Lock	Low Pressure Lock
31	LP Sensor	Low Pressure Sensor Failure
32	Master Lost	Master Lost
33	Phase Loss	Phase Loss
34	Power Lost	Power Lost
35	Power LV	Power Under Voltage
36	Power OV	Power Over Voltage
37	PreHeat Temp	Preheat Temperature
38	Rem Shutdown	Remote Shutdown
39	Ret-T Sensor	Return Temp Sensor Failure
40	Slave Lost	Slave Lost
41	Suc-T Sensor	Suction Temp Sensor Failure
42	Sup-T Sensor	Supply Temp Sensor Failure
43	VFD AccPowRh	VFD Accum PowerOn Rh (Accumulative power-on duration reach)
44	VFD AccRnRch	VFD Accum Run Reach (Accumulative running duration reach)
45	VFD AutoRstF	VFD Auto Reset Fault (Auto reset failure)
46	VFD AutTunEx	VFD Auto Tunning Exc (Auto-tuning exceptions)
47	VFD BrkOvld	VFD Braking Overload (Braking overload)
48	VFD BrkTrstr	VFD Braking TR Fault (Braking transistor fault)
49	VFD CANLIFlt	VFD CANlink Fault (CANlink fault)
50	VFD CANOPFIt	VFD CANopen Fault (CANopen fault)
51	VFD CurSmpEx	VFD Current Sampl Ex (Current sampling exception)
52	VFD DrOverld	VFD ACDrive Overload (AC drive overload)
53	VFD EEProFlt	VFD EEPROM Fault (EEPROM fault)
54	VFD EncodExc	VFD Encoder Exc (Encoder/PG card exceptions)
55	VFD EncoNAct	VFD EncoderCd NotAct (Encoder card not activated)
56	VFD ExpCrdFl	VFD Exp Card Fault (Expansion card fault)
57	VFD ExSpdDev	VFD Excessive SpdDev (Excessive speed deviation)

Table 12.2 Vertiv™ CoolPhase Wall Failure Alarms List (continued)

Item	Alarm	Description
58	VFD ExtAlarm	VFD External Alarms (External Alarms)
59	VFD ExtFault	VFD External Fault (External Fault)
60	VFD InExProt	VFD Input Excep Prot (Input exception protection)
61	VFD InPhLoss	VFD Input Phase Loss (Input phase loss)
62	VFD MODBUSTO	VFD MODBUS Timeout (Modbus timeout)
63	VFD MotOvrld	VFD Motor Overload (Motor overload)
64	VFD MstSIFlt	VFD Master Slave Flt (Master-Slave control fault)
65	VFD MtCntEx1	VFD Motor Ctrl Exc 1 (Motor control exception 1)
66	VFD MtCntEx2	VFD Motor Ctrl Exc 2 (Motor control exception 2)
67	VFD MtOvrspd	VFD Motor Overspeed (Motor overspeed)
68	VFD MtOvrTmp	VFD Motor Overtemp (Motor overtemperature)
69	VFD OutLDLos	VFD Output Load Loss (Output load loss)
70	VFD OutPhLos	VFD OutputPhase Loss (Output phase loss)
71	VFD Overcurr	VFD Overcurrent (Overcurrent)
72	VFD Overheat	VFD Overheat (Overheat)
73	VFD Overvolt	VFD Overvoltage (Overvoltage)
74	VFD ParamExc	VFD Parameter Except (Parameter exceptions)
75	VFD PChrgFlt	VFD Precharge Fault (Precharge fault)
76	VFD PIDFbkLs	VFD PIDFeedback Loss (PID feedback loss)
77	VFD PolPosEr	VFD PolePosition Err (Pole position auto-tuning error)
78	VFD PPLmtFlt	VFD PbyP CurrLim Flt (Pulse-by-pulse current limit fault)
79	VFD PrChgCFI	VFD PrechargeCON Flt (Pre-charge contactor fault)
80	VFD PrChgExc	VFD Precharge CT Exc (Pre-charge circuit exception)
81	VFD ShortGND	VFD Output Short GND (Output short-to-ground)
82	VFD SIfChkF1	VFD Self Check Flt 1 (Self-check fault 1)
83	VFD SIfChkF2	VFD Self Check Flt 2 (Self-check fault 2)
84	VFD SIfChkF3	VFD Self Check Flt 3 (Self-check fault 3)
85	VFD SIfChkF4	VFD Self Check Flt 4 (Self-check fault 4)
86	VFD STO Lock	VFD STO Fault (Safe Torque Off Lock)
87	VFD STOFault	VFD STO Fault (Safe Torque Off fault)
88	VFD TimmgFlt	VFD Timming Fault (Timing fault)
89	VFD Undervol	VFD Undervoltage (Undervoltage)

Table 12.2 Vertiv™ CoolPhase Wall Failure Alarms List (continued)

Item	Alarm	Description
90	VFD UserDfAl	VFD User Def Alarm (User defined alarm)
91	VFD UserDfFl	VFD User Def Fault (User defined fault)
92	VFDShtGNDLck	VFD Short Ground Lock

13 Regulation (EU)

Stationary air conditioners within the European market and operating with R32 Refrigerant must comply with the Reg. (EU) no.2037/2000, starting from 1st Jan, 2015. The R32 refrigerant will be an alternative to the fluorinated greenhouse (F-gas, such R407C, R134a, R410A). According by the EU, from 1st January 2025 the use of refrigerants which have a global warming potential (GWP) greater or equal than 750 will be prohibited in any appliances containing more than 6.6 lb (3 kg) of refrigerant. R32 refrigerant has a GWP indicator of 675.

R32 refrigerant was classified as A2L class. This classification covers all the lower flammability and toxicity level and can be safely used in air conditioning.

Other directives that appliances need to cover are electromagnetic compatibility directive 2014/30/EU, low voltage directive 2006/42/EU, pressure equipment directive 2006/42/EU and restriction of hazardous substances directive 2011/65/EU (and Conformity to EU Directives).

This page intentionally left blank

Appendices

Appendix A: Technical Support and Contacts

A.1 Technical Support/Service in the United States

Vertiv Group Corporation

24x7 dispatch of technicians for all products.

1-800-543-2378

Liebert® Thermal Management Products

1-800-543-2778

Liebert® Channel Products

1-800-222-5877

Liebert® AC and DC Power Products

1-800-543-2378

A.2 Locations

United States

Vertiv Headquarters

505 N Cleveland Ave

Westerville, OH, 43082, USA

Europe

Victor-von-Bruns Strasse 21,

8212 Neuhausen am Rheinfall, Switzerland

Asia

Singapore

151 Lorong Chuan, Lobby D #05-04

New Tech Park, Singapore 556741

India

Vertiv Energy Private Limited

Plot No. C 20, Road No. 19

Wagle Industrial Estate, MIDC

Thane (West), Maharashtra 400604, India

China

Vertiv Technology Co., Limited

Floors 1–4 and 6–10,

Building B2, Nanshan I Park

No. 1001 Xueyuan Road, Nanshan District

Shenzhen, Guangdong 518055, China

Appendix B: Submittal Drawings

For a more detailed view of the circuit diagrams of the three evaporator units, refer to the Submittals Addendum on [Vertiv.com](https://www.vertiv.com)

Document No.	Title	Description
29044985	Electric Submittal for WLM030A	Electrical connections diagram
29044986	Electric Submittal for WLM070A	Electrical connections diagram
29044987	Electric Submittal for WLM110A	Electrical connections diagram

B.1 Circuit Diagram WLM030A

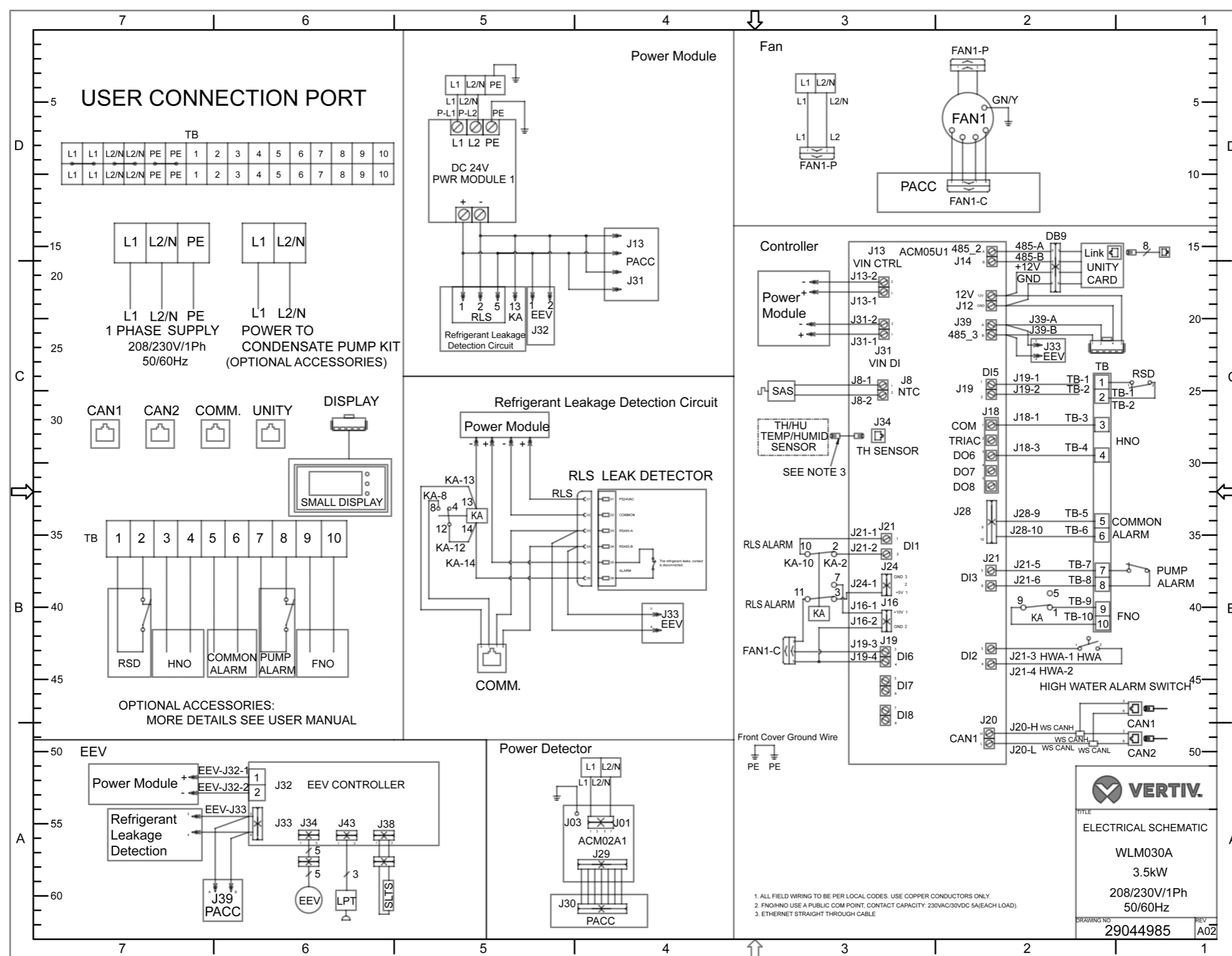

B.2 Circuit Diagram WLM070A

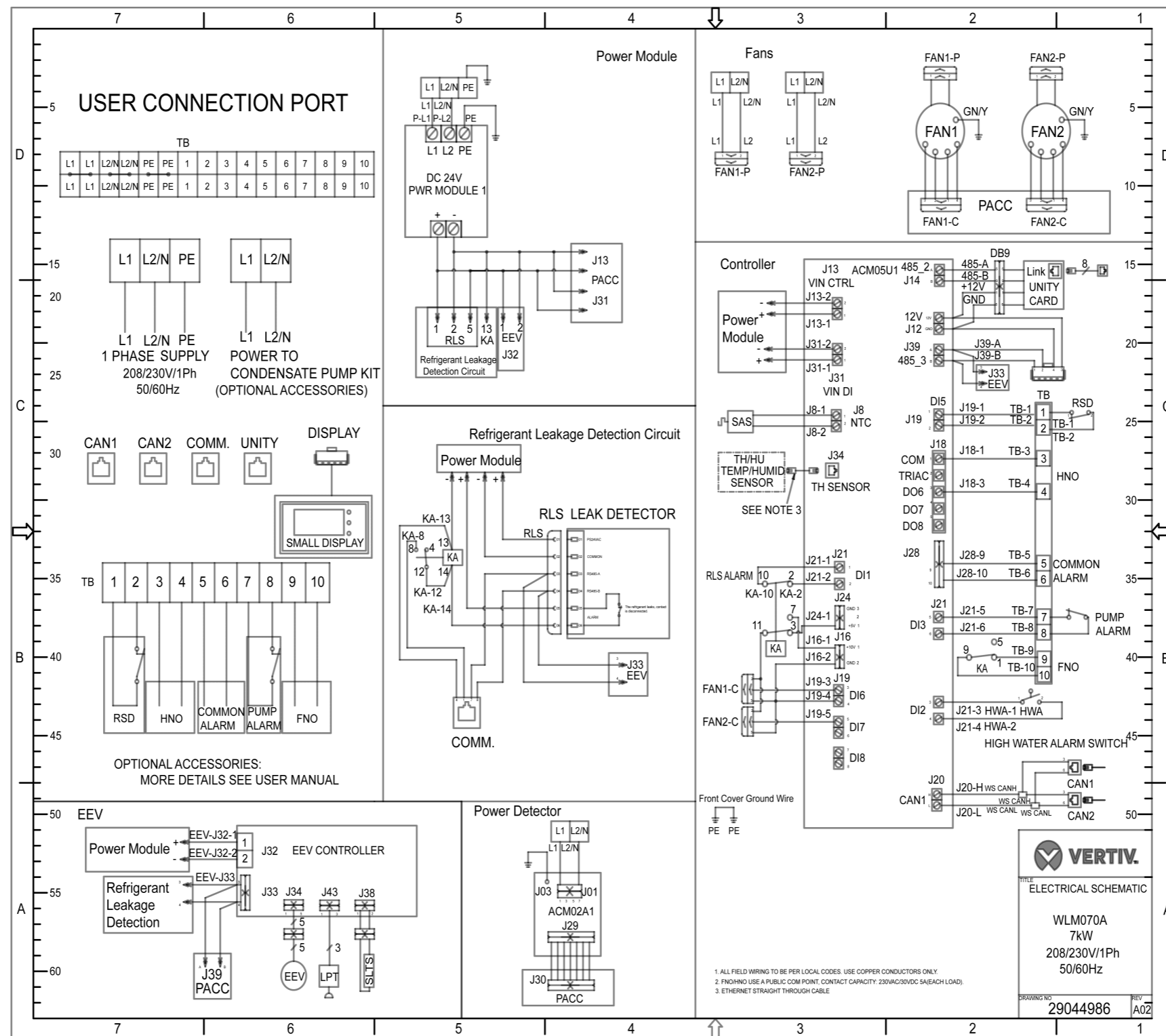

B.3 Circuit Diagram WLM110A

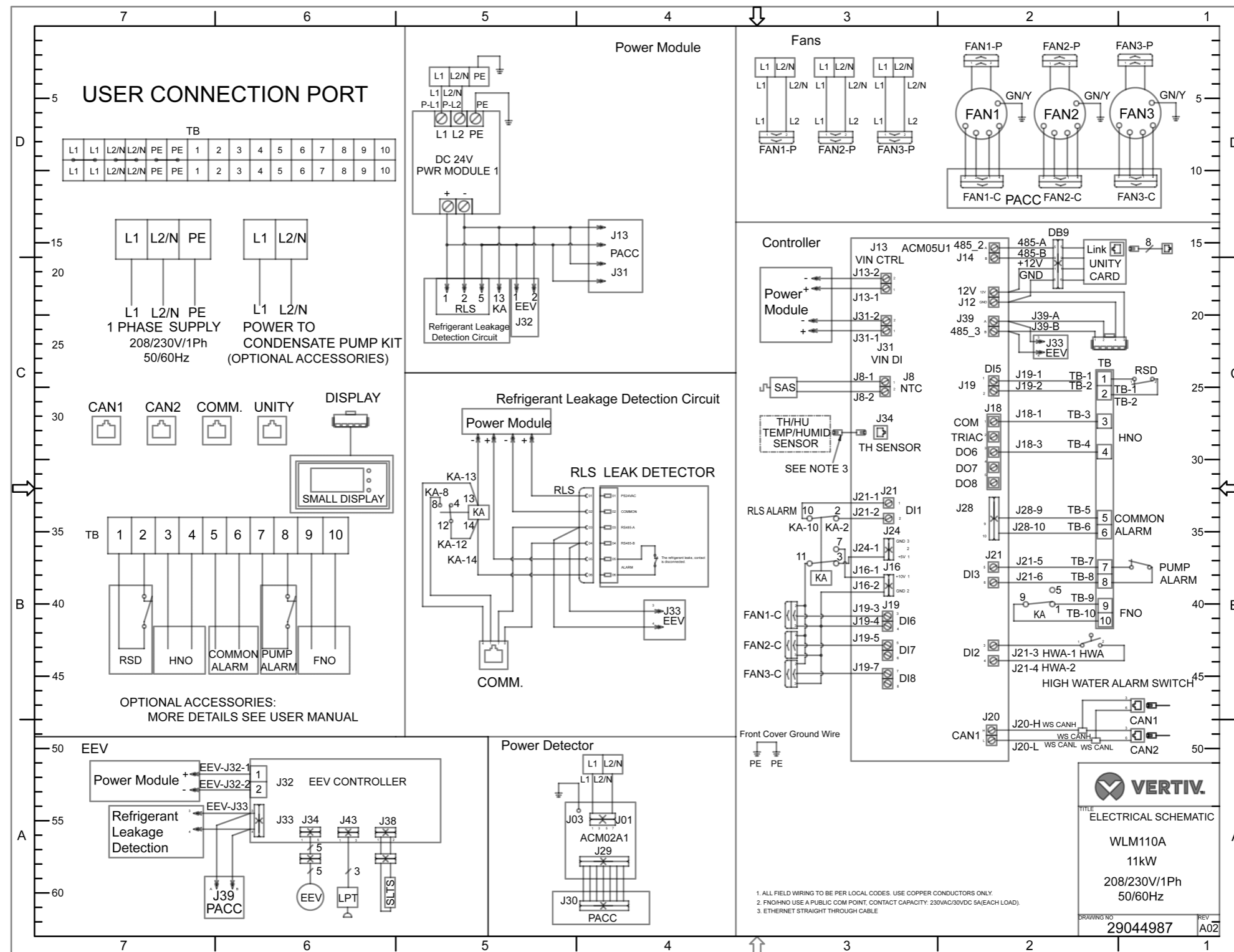

Appendix C: Menu Structure

Level 1	Level 2	Level 3	Parameter	Value
Alarm	Alarms Status			
Alarm	Alarms Log			
Alarm	Alarms Set	Alarm Setpoint	Hi Sup SP: Lo Sup SP: Hi Ret SP: Lo Ret SP: LoDschShSP:	20 to 35 °C (68 to 95 °F) 5 to 20 °C (41 to 68 °F) 30 to 45 °C (86 to 113 °F) 5 to 25 °C (41 to 77 °F) 0 to 20 °C
Alarm	Alarms Set	System Alarms	Comp Comm Comp Drive Comp Lock CompShortCyc Cond Filter CondPumpFail Dsch Temp EEV BatFault EEV Comm EEV DevFault EEV ParaErr EFan Fail Evap Filter Filt Maint Freq Offset Hi Dsch Lock Hi Dsch Temp Hi Ret Temp Hi Sup Temp Hi Water Lvl HP HP Lock HP Sensor HP Sw Alarm HP Sw Lock Lo Ret Temp Lo Sup Temp LoDschSHLock LoDschSHTemp LP	EN/DIS

Level 1	Level 2	Level 3	Parameter	Value
			LP Lock	
			LP Sensor	
			Master Lost	
			Phase Loss	
			Power Lost	
			Power LV	
			Power OV	
			PreHeat Temp	
			Rem Shutdown	
			Ret-T Sensor	
			Slave Lost	
			Suc-T Sensor	
			Sup-T Sensor	
			VFD AccPowRh	
			VFD AccRnRch	
			VFD AutoRstF	
			VFD AutTunEx	
			VFD BrkOvrlD	
			VFD BrkTrstr	
			VFD CANLIFlt	
			VFD CANOPFlt	
			VFD CurSmpEx	
			VFD DrOverld	
			VFD EEProFlt	
			VFD EncodExc	
			VFD EncoNAct	
			VFD ExpCrdFl	
			VFD ExSpdDev	
			VFD ExtAlarm	
			VFD ExtFault	
			VFD InExProt	
			VFD InPhLoss	
			VFD MODBUSTO	
			VFD MotOvrlD	
			VFD MstSlFlt	
			VFD MtCntEx1	
			VFD MtCntEx2	
			VFD MtOvrspd	
			VFD MtOvrTmp	

Level 1	Level 2	Level 3	Parameter	Value
			VFD OutLDLos VFD OutPhLos VFD Overcurr VFD Overheat VFD Overvolt VFD ParamExc VFD PChrgFlt VFD PIDFbkLs VFD PolPosEr VFD PPLmtFlt VFD PrChgCFI VFD PrChgExc VFD ShortGND VFD SlfChkF1 VFD SlfChkF2 VFD SlfChkF3 VFD SlfChkF4 VFD STO Lock VFD STOFault VFD TimmgFlt VFD Undervol VFD UserDfAI VFD UserDFtl VFDShGNDLck	
Alarm	Alarms Set	Alarm Handle	Rst Evap Filter Evap Filter RT Evap Filter Maint Rst Cond Filter Cond Filter RT Cond Filt Maint: Gen Alm Pol: CPF Alm Pol:	YES/NO \ 30/360D YES/NO \ 30/360D N.On/N.Off N.C./N.O.
Power			L1 - N Frequency Power OV Power LV Power OV Power LV	 EN/DIS/MSG EN/DIS/MSG

Level 1	Level 2	Level 3	Parameter	Value
			Freq Offset	EN/DIS/MSG
			Phase loss	EN/DIS/MSG
Temperature			Ctrl Sensor: Return / Supply SP: Temp DB:	RET/SUP 18 to 40 °C / 18 to 27°C (64.4°F – 104°F / 64.4°F – 80.6°F) 0.0°C - 2.0°C
Humidity			Humidity: Hum DB SP: Hum Output: Hi Hum SP: Lo Hum SP:	1.0% - 99.0% 1.0% - 5.0% ON/OFF 50.0 - 99.0% 1.0% - 50.0%
System Status	Run Time		Evap Fan Compressor Evap Filter Humid CondFan Cond Filter	
System Status	Run State		HP LP Dsch Temp Comp Cap Fan Speed	
System Status	Environment		Sup Temp Sup-T Cal Ret Temp Ret-T Cal Dsch Temp Dsch-T Cal Suc Temp SH HP HP Cal HP Abnor... LP LP Cal LP Delay Humidity Hum Cal	(Information only)

Level 1	Level 2	Level 3	Parameter	Value
			EEV Open	
System Status	Switch In/Out		Rem Switch Rem Sw Pol Fan Output Comp Output Gen Alm DIP SW	ON/OFF N.O./N.C. ON/OFF ON/OFF ON/OFF \
System Set	Common Set		Mon Addr Baud Rate	1-247 1200/2400/4800/ 9600/19200/57600/115200
System Set	Display		Contrast BackLight Language Unit	30 to 58 500 to 1023 En, Sp, Pol, Ger, Fr, It Metric / Imperial
System Set	Date & Time		Date (Y) Date (M) Date (D) Time (H) Time (M) Time (S)	2000 to 2099 Years 1 to 12 Jan-Dec 1 to 31 Mon-Sun 0 to 24 Hr 0 to 59 Min 0 to 59 Seg
System Set	Password		PW Level 1 PW Level 2	
Help	Version Info			
Help	Service Info			

Appendix D: Conformity to EU Directives

Fabbricante-Manufacturer-Hersteller-Fabricant-Fabricante

Fabricante- Tillverkare – Fabrikant – Valmistaja – Produsent Fabrikant – Κατασκευαστής – Producent

Il Fabbricante dichiara che questo prodotto è conforme alle direttive Europea:

The Manufacturer here by declares that this product conforms to the European Union directives:

Der Hersteller erklärt hiermit, dass dieses Produkt den Anforderungen der europäischen Richtlinien gerecht wird: Le Fabrican déclare que ce produit est conforme aux directives Européennes:

El Fabricante declara que este producto es conforme a las directivas Europeas:

O Fabricante declara que este produto está em conformidade com as directivas Europeias: Tillverkare försäkrar härmed att denna produkt överensstämmer med Europeiska Uniones direktiv: De Fabrikant verklaart dat dit product conform de Europese richtlijnen is:

Vaimistaja vakuuttaa täten, että tämä tuote täyttää seuraavien EU-direktiivien vaatimukset: Produsent erklærer herved at dette produktet er i samsvar med EU-direktiver:

Fabrikant erklærer herved, at dette product opfylder kravene i EU direktiverne:

κατασκευαστής δηλώνει ότι ο παρών προϊόν εβναι άατα ασάευαμύνο άγμ ωνα με τ ή οδηγεί τ η Ε.Ε.:

Directive	Standard(s)
Electromagnetic Compatibility Directive 2014/30/EU	EN IEC 61000-6-2:2019 EN IEC 61000-6-4:2019
Low Voltage Directive 2014/35/EU	EN 60335-1:2012+AC:2014+A11:2014 +A13:2017+A15:2021 EN 60335-2-40:2003/A13:2012
Machinery Directive 2006/42/EU	EN 60335-1:2012+AC:2014+A11:2014 +A13:2017+A15:2021 EN 60335-2-40:2003/A13:2012 ISO 12100:2010
Pressure Equipment Directive 2014/68/EU	EN 378-2:2016
Restriction of Hazardous Substances Directive 2011/65/EU	EN 63000:2018

Appendix E: Conformity to UK Legislations

The product is in compliance with the following directives:

Legislation	Standard(s)
Electromagnetic Compatibility Regulations 2016	EN IEC 61000-6-2:2019 EN IEC 61000-6-4:2019
Electrical Equipment (Safety) Regulations 2016	EN 60335-1:2012+AC:2014+A11:2014 +A13:2017+A15:2021 EN 60335-2-40:2003/A13:2012
Supply of Machinery (Safety) Regulations 2008	EN 60335-1:2012+AC:2014+A11:2014 +A13:2017+A15:2021 EN 60335-2-40:2003/A13:2012 ISO 12100:2010
Pressure Equipment (Safety) Regulations 2016	EN 378-2:2016
The Restriction of the Use of Certain Hazardous Substances in Electrical and Electronic Equipment Regulations 2012	EN 63000:2018

This page intentionally left blank

Connect with Vertiv on Social Media



<https://www.facebook.com/vertiv/>



<https://www.instagram.com/vertiv/>



<https://www.linkedin.com/company/vertiv/>



<https://www.x.com/Vertiv/>



Vertiv.com | Vertiv Headquarters, 505 N Cleveland Ave, Westerville, OH 43082 USA

©2026 Vertiv Group Corp. All rights reserved. Vertiv™ and the Vertiv logo are trademarks or registered trademarks of Vertiv Group Corp. All other names and logos referred to are trade names, trademarks or registered trademarks of their respective owners. While every precaution has been taken to ensure accuracy and completeness here, Vertiv Group Corp. assumes no responsibility, and disclaims all liability, for damages resulting from use of this information or for any errors or omissions.

SL-71138_REVC_04-26