



Liebert® APM2 Battery Cabinet

User Manual

400V Modular EBC - CE Rated

The information contained in this document is subject to change without notice and may not be suitable for all applications. While every precaution has been taken to ensure the accuracy and completeness of this document, Vertiv assumes no responsibility and disclaims all liability for damages result from use of this information or for any errors or omissions.

Refer to local regulations and building codes relating to the application, installation, and operation of this product. The consulting engineer, installer, and/or end user is responsible for compliance with all applicable laws and regulations relation to the application, installation, and operation of this product.

The products covered by this instruction manual are manufactured and/or sold by Vertiv. This document is the property of Vertiv and contains confidential and proprietary information owned by Vertiv. Any copying, use, or disclosure of it without the written permission of Vertiv is strictly prohibited.

Names of companies and products are trademarks or registered trademarks of the respective companies. Any questions regarding usage of trademark names should be directed to the original manufacturer.

Technical Support Site

If you encounter any installation or operational issues with your product, check the pertinent section of this manual to see if the issue can be resolved by following outlined procedures.

Visit <https://www.vertiv.com/en-us/support/> for additional assistance.

TABLE OF CONTENTS

1 Important Safety Instructions	1
2 Mechanical Installation	5
2.1 Introduction	5
2.2 System Composition	5
2.3 Preliminary Checks	5
2.4 Battery Cabinet Installed	6
2.4.1 Handling and Unpacking the Unit	6
2.4.2 Battery Cabinet and UPS Cabinet Combined	7
2.4.3 Unpacking and Installing the Battery Module	7
2.5 Battery Room	11
2.5.1 Storing Batteries for Delayed Installation	12
2.5.2 Installation Considerations	12
2.6 Moving and Fixed installation	12
2.6.1 Moving the Battery Cabinets	12
2.6.2 Raised-Floor Mounting	13
2.7 Layout	15
2.7.1 Connecting the Vertiv™ Liebert® APM2 Modular External Battery Cabinet to the UPS	15
2.7.2 Wiring Schematic	15
3 Battery Module Installation	17
3.1 Safety	17
3.1.1 Connecting the Batteries	19
3.1.2 Grounding	19
3.2 Control Connection	19
3.3 Battery Module Information	19
3.3.1 Floor Installation	20
3.3.2 Cable Entry	20
3.4 Wiring	21
3.4.1 Battery Cabinet Interface Connectors	21
3.5 Vertiv™ Liebert® APM2 Modular EBC Monitoring System	25
3.6 Circuit Breaker Control Cable Wiring	26
3.7 Battery Protection	26
3.7.1 Battery Low-Voltage Warning	26
3.7.2 Battery End of Discharge Protection	26
3.8 Vertiv™ Liebert® APM2 EBC Backup Times	26
3.8.1 The Backup Time	27
3.8.2 Battery Cabinet Energy	27
4 Installation Drawings	29

- 4.1 Cabinet Installation Diagram 29
- 4.2 System Inspection and Power-on 29
 - 4.2.1 Preparation before Power-on 29
 - 4.2.2 Power on Steps 29
 - 4.2.3 Shutdown Steps 29
- 4.3 Battery Module Maintenance 29
- 5 Specifications 31**
- 6 Maintenance 33**
- 6.1 Record Log 33
- 6.2 Battery Maintenance 33
- 6.3 Battery Safety Precautions 33
- 6.4 Torque Requirements 35
- Appendices 37**
- Appendix A: Technical Support and Contacts 37

1 Important Safety Instructions

Save these instructions

This manual contains important instructions that should be followed during installation of Vertiv™ Liebert® APM2 Modular External Battery Cabinet and accessories. Read this manual thoroughly, paying special attention to the sections that apply to user specific installation, before working with the battery system. Retain this manual for use by installing personnel.

The following warning applies to all battery cabinets supplied with UPS systems.



WARNING!

Internal battery strapping must be verified prior to moving a battery cabinet (after initial installation). Battery cabinets contain non-spillable batteries. Keep units upright, do not stack or tilt. Failure to adhere to this warning could result in smoke, fire or electric hazard. Call 1-800-548-2378 prior to moving battery cabinets (after initial installation).



AVERTISSEMENT!

Le cerclage interne de la batterie doit être vérifié avant de déplacer une armoire de batterie (après l'installation initiale). Les armoires à batteries contiennent des batteries étanches. Gardez les unités à la verticale. Ne pas empiler. Ne pas incliner. Le non-respect de cet avertissement pourrait entraîner de la fumée, un incendie ou un risque électrique. Appelez le 1-800-548-2378 avant de déplacer les armoires de batteries (après l'installation initiale).



WARNING! Risk of electric shock. Can cause personal injury and death. Check for voltage with both AC and DC voltmeters before working within the EBC and before making contact. Only properly trained and qualified personnel wearing appropriate safety headgear, gloves, shoes and glasses should be involved in installing the EBC or preparing the EBC for installation. When performing maintenance with any part of the equipment under power, service personnel and test equipment should be standing on rubber mats. Lead-acid batteries contain hazardous materials. Batteries must be handled, transported and recycled or discarded in accordance with federal, state and local regulations. Because lead is a toxic substance, lead-acid batteries must be recycled rather than discarded. Do not dispose of battery or batteries in a fire, the battery may explode. Do not open or mutilate the battery or batteries. Released electrolyte is harmful to the skin and eyes, it is toxic.

The following precautions must be observed when working on batteries:

- Remove watches, rings and other metal objects.
- Use tools with insulated handles.
- Wear rubber gloves and boots.
- Do not lay tools or metal parts on top of batteries.
- Disconnect charging source prior to connecting or disconnecting battery terminals.
- Determine whether the battery is grounded. If it is grounded, remove source of ground. Contact with any part of a grounded battery can result in electrical shock. The likelihood of such shock will be reduced if such grounds are removed during installation and maintenance.



AVERTISSEMENT! Risque de décharge électrique pouvant causer des blessures graves, voire mortelles. Vérifiez les tensions au moyen de voltmètres c.a. et c.c. avant d'utiliser le système ASC. Vérifiez les tensions avec des voltmètres c.a. et c.c. avant d'établir tout contact. Seuls des employés qualifiés et dûment formés portant un casque, des gants, des chaussures et des lunettes de sécurité adéquats doivent se charger d'installer le système ASC ou de le préparer pour l'installation. Les responsables de l'entretien et l'équipement d'essai doivent reposer sur des tapis de caoutchouc lors de toute intervention sur une pièce d'équipement sous tension. Les batteries au plomb-acide renferment des matières dangereuses. Les batteries doivent être manipulées, transportées, recyclées ou jetées conformément aux règlements fédéraux, provinciaux et municipaux. Étant donné que le plomb est une substance toxique, les batteries au plomb-acide doivent être recyclées plutôt que mises au rebut. Ne jetez jamais de batteries au feu car elles risquent d'exploser. Vous ne devez ni ouvrir ni percer les batteries, car l'électrolyte qui s'en écoulait est nocif pour la peau et les yeux. Cet électrolyte est toxique.

Lorsque vous travaillez avec des batteries, prenez les précautions suivantes:

- Retirez montre, bagues et tout autre objet métallique.
- Utilisez des outils dont le manche est isolé.
- Portez des gants et des bottes de caoutchouc.
- Ne posez aucun outil ni pièce métallique sur le dessus d'une batterie.
- Déconnectez la source de chargement avant de brancher ou de débrancher les bornes d'une batterie.
- Vérifiez si la batterie est mise à la terre. Le cas échéant, éliminez la cause de la mise à la terre. Le contact avec toute partie d'une batterie mise à la terre peut provoquer une décharge électrique. Pour réduire de tels risques d'accident, débranchez les prises de terre avant de procéder à l'installation ou à l'entretien.



WARNING! Risk of electric shock. Can cause personal injury and death. In case of fire involving electrical equipment, use only carbon dioxide fire extinguishers or those approved for use in fighting electrical fires.



AVERTISSEMENT! Risque de décharge électrique pouvant causer des blessures graves, voire mortelles. En cas d'incendie associé à du matériel électrique, n'utilisez que des extincteurs à dioxyde de carbone ou homologués pour la lutte contre les incendies d'origine électrique.



WARNING! Risk of heavy unit falling over. Improper handling can cause equipment damage, injury or death. Exercise extreme care when handling battery cabinets to avoid equipment damage or injury to personnel. The battery system cabinets weigh from 3000 lbs or 1362 kg, (empty cabinet is 816 lbs or 320 kg). Locate center of gravity symbols and determine unit weight before handling each cabinet. Test lift and balance the cabinets before transporting. Maintain minimum tilt from vertical at all times. Slots at the base of the module cabinets are intended for forklift use. Base slots will support the unit only if the forks are completely beneath the unit. Read all of the following instructions before attempting to move, lift, or remove packaging from unit, or prepare unit for installation.



AVERTISSEMENT! Risque de chute d'une unité lourde. Une mauvaise manipulation peut entraîner des dommages matériels, des blessures, voire la mort. Faites preuve d'une extrême prudence lors de la manipulation des armoires de batteries pour éviter d'endommager l'équipement ou de blesser le personnel. L'armoire de batterie (y compris les modules de batterie) pèse 3 000 lb ou 1 362 kg (l'armoire vide pèse 816 lb ou 320 kg). Localisez les symboles du centre de gravité et déterminez le poids unitaire avant de manipuler chaque armoire. Testez le levage et l'équilibre des armoires avant le transport. Maintenez à tout moment une inclinaison minimale par rapport à la verticale. Les fentes à la base des armoires modulaires sont destinées à être utilisées par un chariot élévateur. Les fentes de base soutiendront l'unité uniquement si les fourches sont complètement sous l'unité. Lisez toutes les instructions suivantes avant d'essayer de déplacer, de soulever ou de retirer l'emballage de l'unité, ou de préparer l'unité pour l'installation.



WARNING! Risk of electrical shock and fire. Can cause equipment damage, personal injury, or death. Under typical operation and with all EBC doors closed, only normal safety precautions are necessary. The area around the EBC system should be kept free of puddles of water, excess moisture, and debris. Only test equipment designed for troubleshooting should be used. This is particularly true for oscilloscopes. Always check with an AC and DC voltmeter to ensure safety before making contact or using tools. Even when the power is turned Off, dangerously high potential electric charges may exist at the capacitor banks and at the DC connections. All wiring must be installed by a properly trained and qualified electrician. All power and control wiring must comply with all applicable national, state, and local codes. One person should never work alone, even if all power is disconnected from the equipment. A second person should be standing by to assist and to summon help in case of an accident.



AVERTISSEMENT! Risque de choc électrique et d'incendie. Peut causer des dommages matériels, des blessures ou la mort. Dans des conditions de fonctionnement normales et avec toutes les portes de l'EBC fermées, seules les précautions de sécurité normales sont nécessaires. La zone autour du système EBC doit être exempte de flaques d'eau, d'excès d'humidité et de débris. Seul l'équipement de test conçu pour le dépannage doit être utilisé. Cela est particulièrement vrai pour les oscilloscopes. Vérifiez toujours avec un voltmètre AC et DC pour garantir la sécurité avant de prendre contact ou d'utiliser des outils. Même lorsque l'alimentation est coupée, des charges électriques potentielles dangereusement élevées peuvent exister au niveau des batteries de condensateurs et des connexions CC. Tout le câblage doit être installé par un électricien dûment formé et qualifié. Tout le câblage d'alimentation et de commande doit être conforme à tous les codes nationaux, étatiques et locaux applicables. Une personne ne doit jamais travailler seule, même si toute alimentation électrique est coupée de l'équipement. Une deuxième personne doit être prête à intervenir et à demander de l'aide en cas d'accident.



WARNING! This is a product for commercial and industrial application in the second environment – installation restrictions or additional measures may be needed to prevent disturbances.



AVERTISSEMENT! Il s'agit d'un produit destiné à une application commerciale et industrielle dans le deuxième environnement – des restrictions d'installation ou des mesures supplémentaires peuvent être nécessaires pour éviter les perturbations.

NOTICE

This unit complies with the limits for a Class A digital device, pursuant to Part 15 Subpart B of the FCC rules. These limits provide reasonable protection against harmful interference in a commercial environment. This unit generates, uses and radiates radio frequency energy and, if not installed and used in accordance with this instruction manual, may cause harmful interference to radio communications. Operation of this unit in a residential area may cause harmful interference that the user must correct at his own expense.

This device complies with part 15 of the FCC Rules. Operation is subject to the following two conditions:

1. This device may not cause harmful interference, and
2. This device must accept any interference received, including interference that may cause undesired operation.

2 Mechanical Installation

2.1 Introduction

This section describes the requirements that must be taken into account when planning the positioning and cabling of the Vertiv™ Liebert® APM2 Modular EBC equipment. This chapter is a guide to general procedures and practices that should be observed by the installing engineer. The conditions of each site will determine the applicability of such procedures.

NOTICE

Risk of improper startup. Can cause equipment damage. Do not apply electrical power to the EBC equipment before the arrival of the commissioning engineer.

2.2 System Composition

The battery cabinet consists of a rack and battery modules. Each cabinet contains 4-32 battery modules or can be configured modular 4-32 batteries depending on run-time required. The battery modules will be shipped separately. The battery module will be installed by engineers at the customer site. Please refer to the figure below to understand the cabinet structure.

Figure 2.1 System Composition

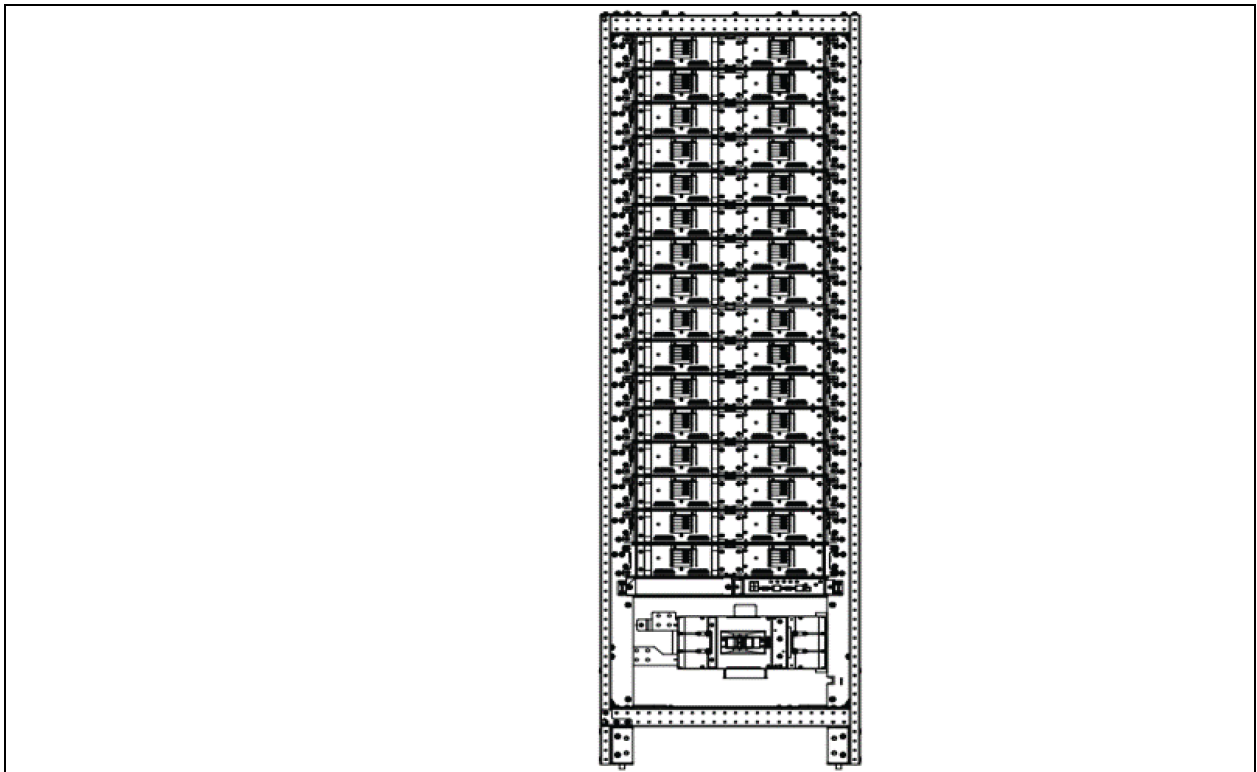

2.3 Preliminary Checks

Before installing the battery equipment, carry out the following preliminary checks:

- Remove all panels and visually inspect the cabinet, battery modules, bus connections, and cabinet for any shipping damage. Be careful, there is voltage in the battery modules prior to installation. If there is evidence of damage, do not proceed. Call Vertiv at 1-800-542-2378.
- Report any damage to the shipper immediately.
- Verify that the correct equipment is being installed. The equipment supplied has an identification tag inside the main door.
- Verify that the battery room satisfies the environmental conditions stipulated in the equipment specification, paying particular attention to the ambient temperature and air exchange system.

2.4 Battery Cabinet Installed

2.4.1 Handling and Unpacking the Unit

The unit weighs up to 771.61 lb (350 kg), depending on the options selected. The modular EBC is shipped on a pallet and is equipped with casters that permit two or more people to roll it off the pallet for installation. Use a forklift or pallet jack to move the palletted modular EBC as close as possible to the installation location before removing packing material or loosening shipping brackets.

Figure 2.2 Handling and Unpacking the Unit

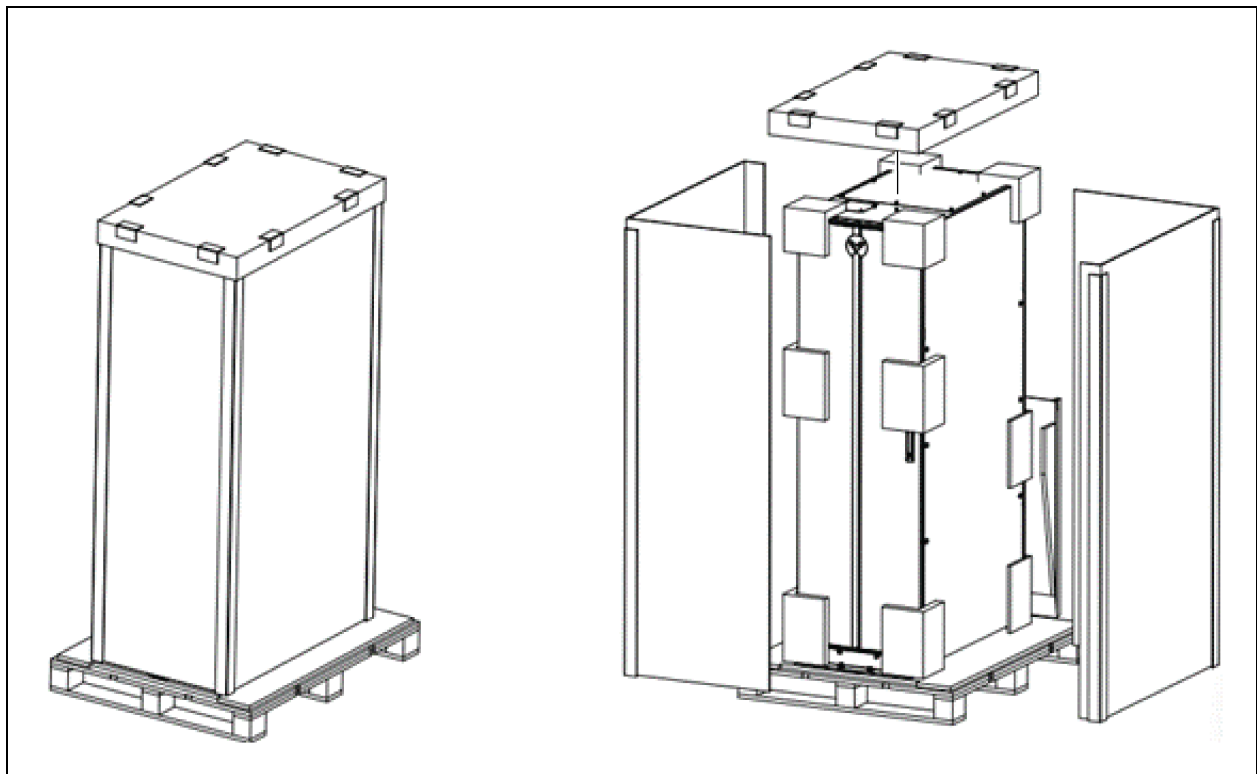

The order of removing packaging materials is as follows :

1. Remove the protective packaging, shown in the illustration above.
2. Locate the accessories package on top of the modular EBC and set aside.
3. Use a 5/8 in. (16 mm) wrench or socket to remove the shipping brackets from the pallet.
4. Remove the shipping brackets from the front and rear of the modular EBC.

5. Ensure that the leveling feet are raised to prevent interference when rolling the unit on the casters.
6. Roll the unit down the ramp to the installation location then lower the leveling feet to fix the modular EBC at the installation location.

2.4.2 Battery Cabinet and UPS Cabinet Combined

Figure 2.3 Battery Cabinet and UPS Cabinet Combined

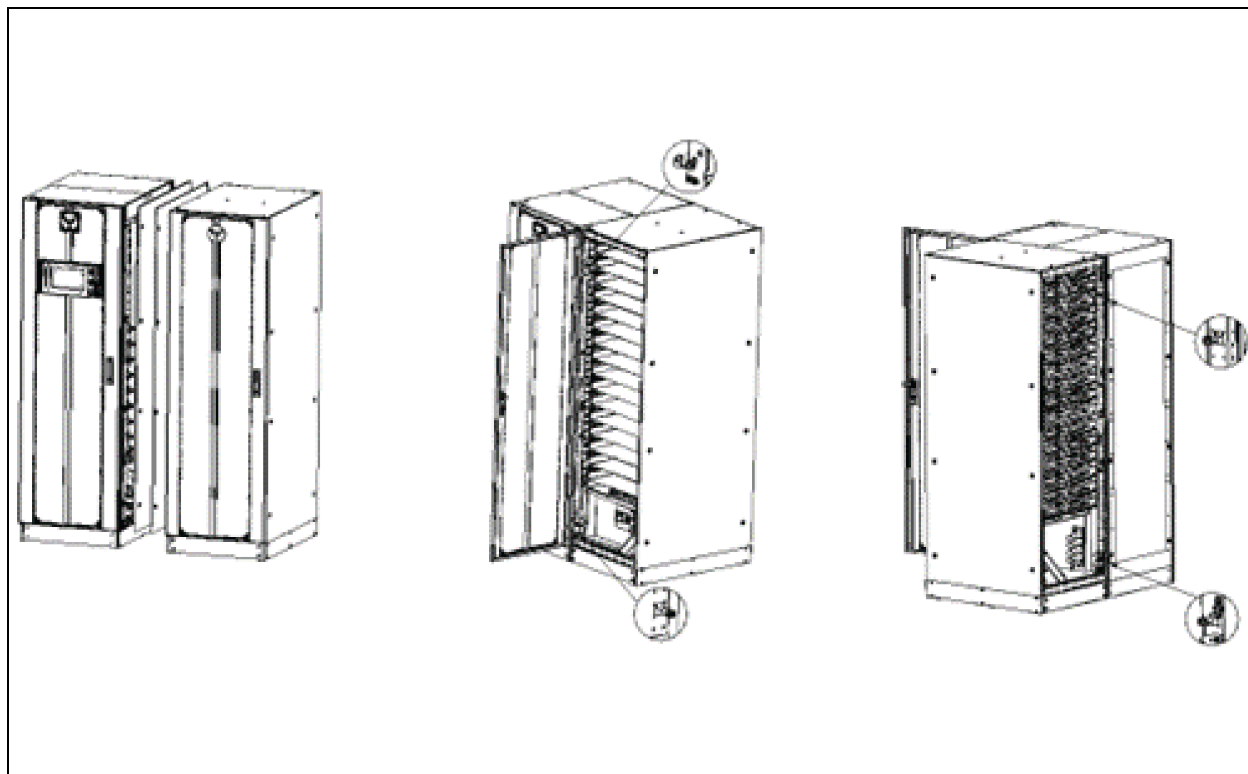

The process of combining battery cabinet and UPS cabinet is as follows (Only FR1 UPS cabinet can be combined):

1. Remove the right door panel of the battery cabinet.
2. Remove the left door panel of the FR1 power cabinet.
3. After the battery cabinet is aligned with the FR1 UPS cabinet, open the front door panel of the battery cabinet, and secure the battery cabinet to the UPS cabinet at the top and bottom using 2 M8x25 screws (the support at the bottom of the battery cabinet needs to be temporarily removed).
4. Remove the rear door panel of the battery cabinet, and secure the battery cabinet to the UPS cabinet at the top and bottom using 2 M8x25 screws (the support at the bottom of the battery cabinet needs to be temporarily removed).
5. Install the battery cabinet rear door panel and close the front door panel.

2.4.3 Unpacking and Installing the Battery Module

The modular battery is packaged in a box, and the internal mechanism of the box is as shown in **Figure 2.5** on page 9. Open the box and remove the Plastic Bag. Then remove the battery module from the case, as shown in **Figure 2.4** on the next page.

Figure 2.4 Battery Cabinet Components

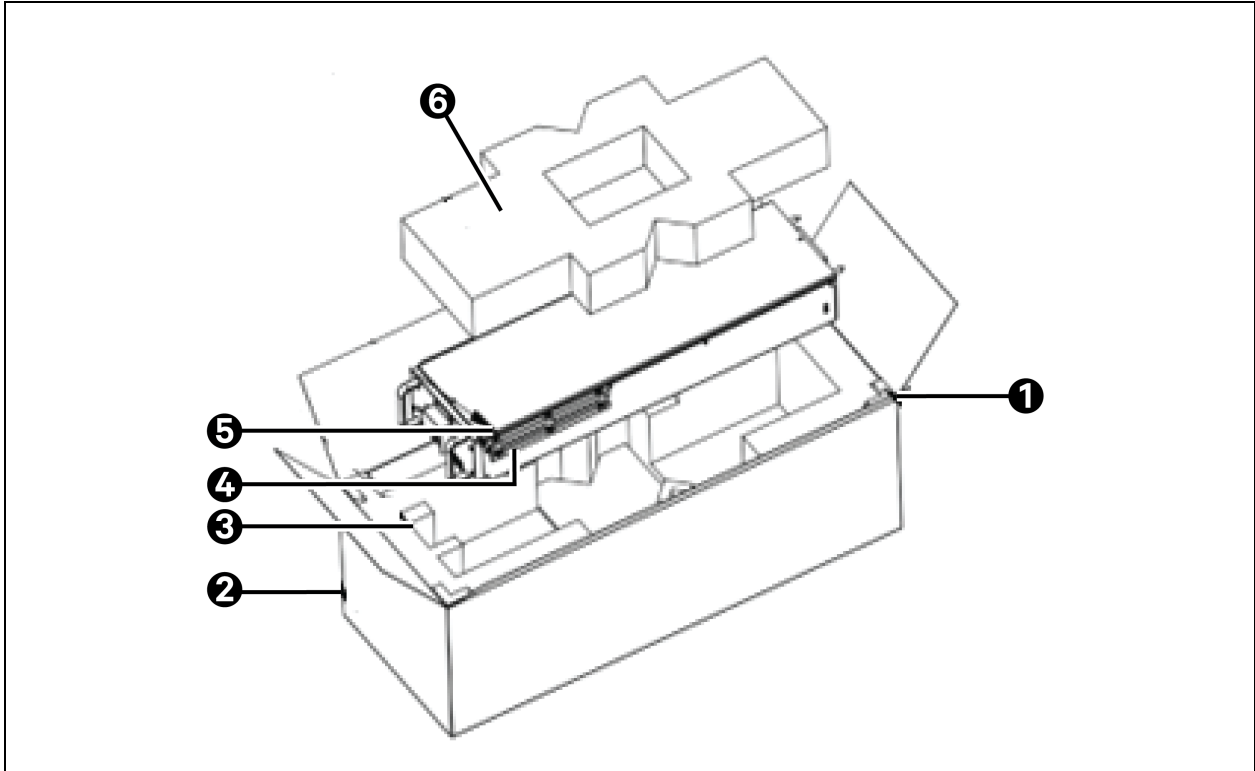

Item	Description
1	Cartoon
2	Wooden Conner
3	Desiccant
4	EPE Cushion
5	EPE Cushion
6	Plastic Bag

NOTE: At least two workers are required to disassemble and install the battery module. Please pay attention to safety and avoid injury.

1. Prepare the battery module before installing it into the cabinet.
 - If the module needs to be installed on the left side of the cabinet, secure the L-shaped mounting ears in the accessory bag to the left side of the module using 2 M4x8 screws. Fix the baffle in the accessory bag on the right side of the module with M4x8 screws (2pcs). Install the pin in the accessory bag on the back panel of the module.

Figure 2.5 Preparing the Battery Module

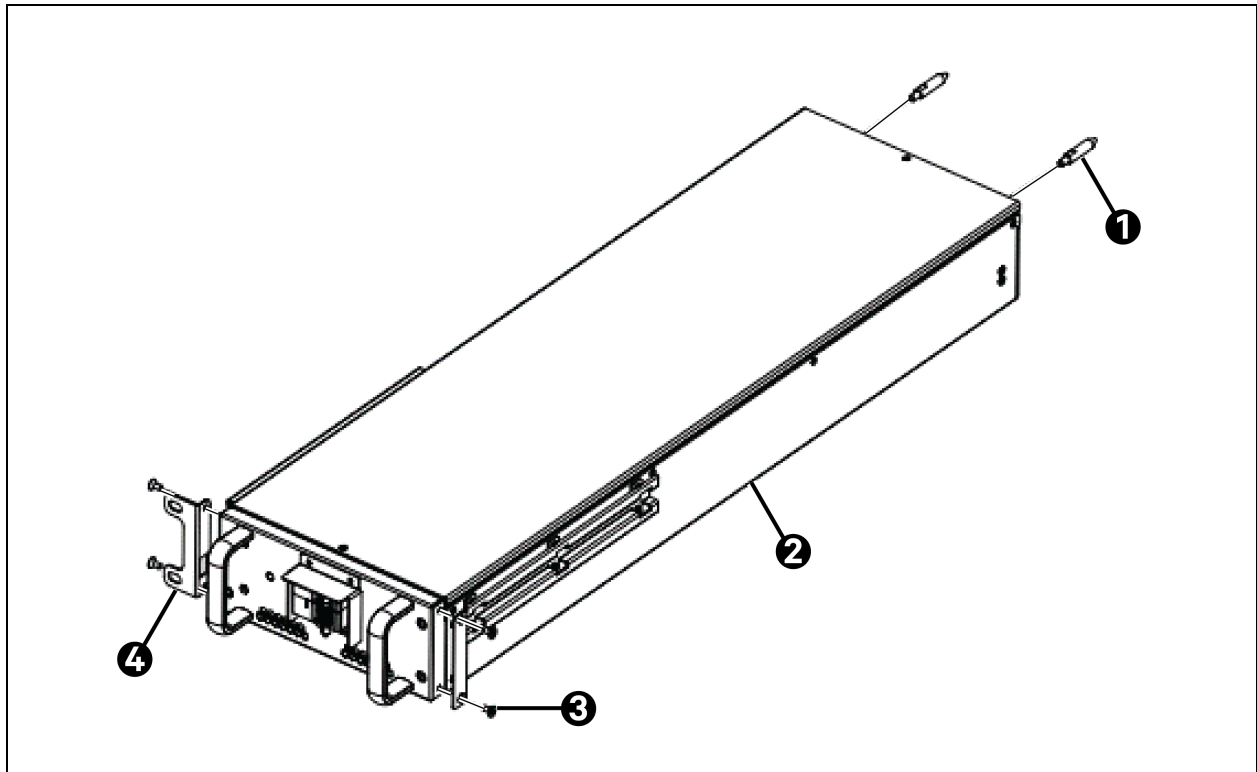

- If the module needs to be installed on the right side of the cabinet, secure the L-shaped mounting ears in the accessory bag to the right side of the module using 2 M4x8 screws. Fix the baffle in the accessory bag on the left side of the module with M4x8 screws (2pcs). Install the pin in the accessory bag on the back panel of the module.

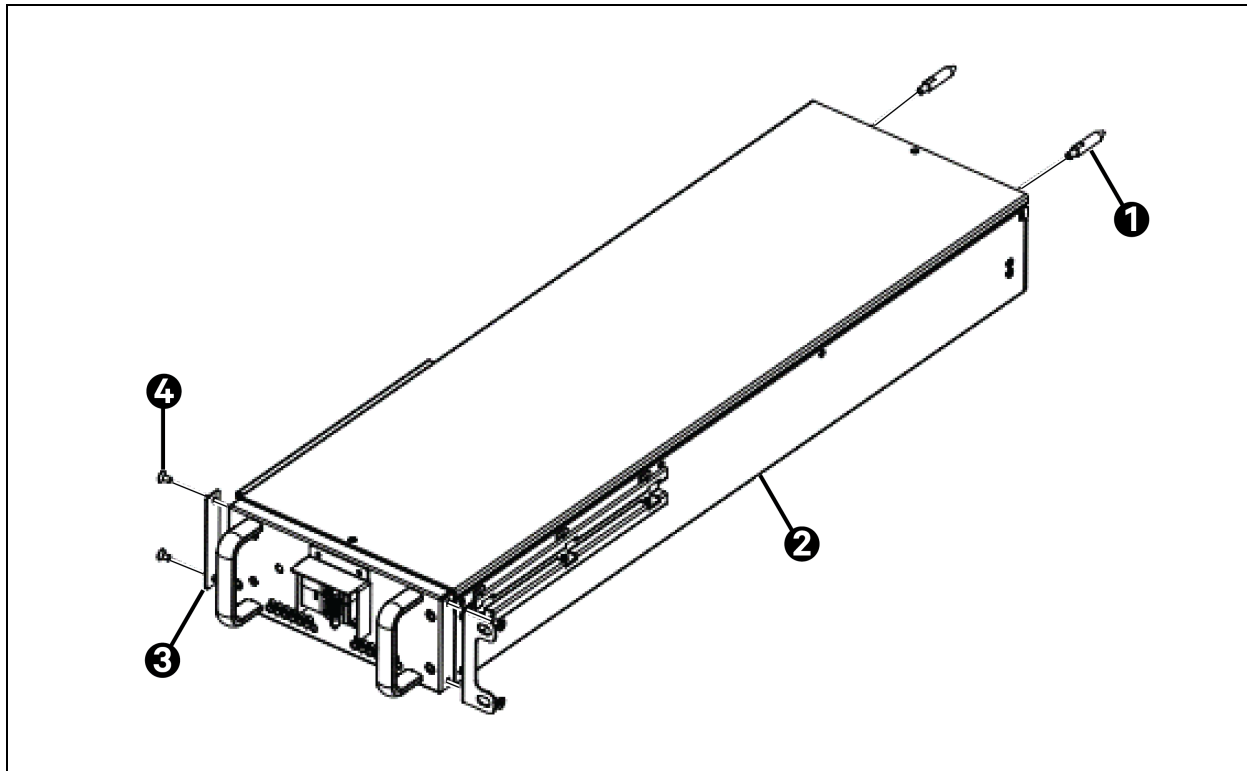

2. Install the battery module into the cabinet.

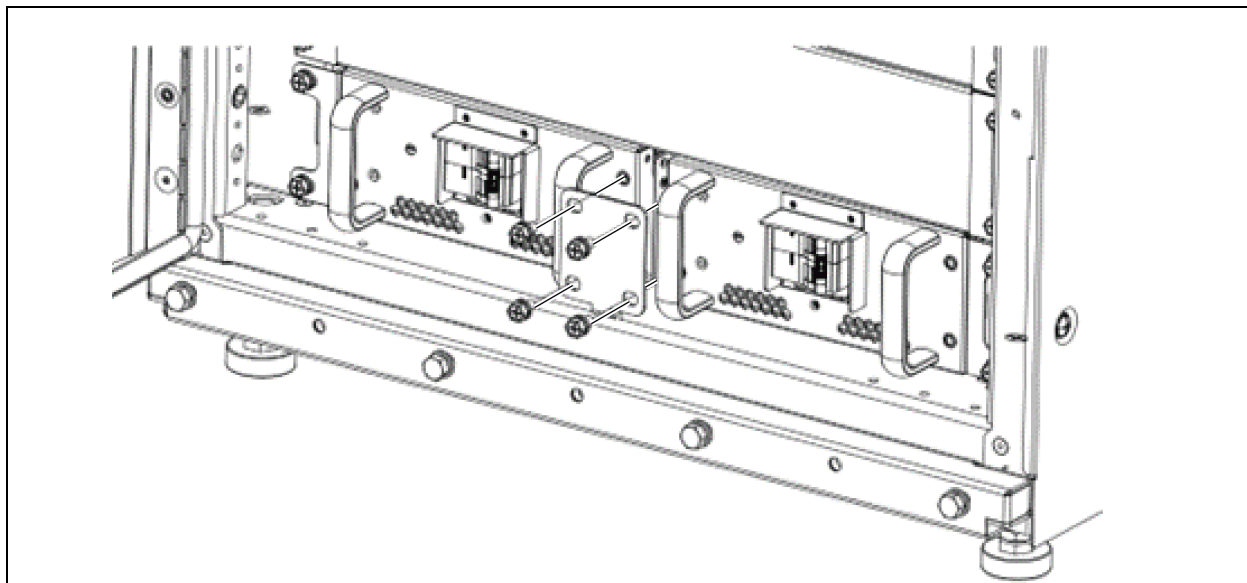

The steps to install the battery module are as follows:

1. Remove the module baffle (if any).
2. Push the module pre-installed in the previous step according to the left picture into the cabinet along the far left side and fix it with the M6x12 screws (2pcs) in the accessory bag.

3. Push the module pre-installed in the previous step according to the right picture into the cabinet along the far right side and fix it with the M6x12 screws (2pcs) in the accessory bag.
4. Take out the module connector from the battery accessories and fix it with M6x12 screws (4pcs).
5. Install all battery modules from low to high.

2.5 Battery Room

Batteries should be installed in an environment where the temperature is consistent and even over the whole battery. Temperature is a major factor in determining the battery life and capacity. Typical battery manufacturer performance data are quoted for an operating temperature between 68 °F and 77 °F (20 °C and 25 °C). Operating above this range will reduce the battery life while operation below this range will reduce the battery capacity.

Battery Temperature: In a normal installation, the battery temperature should be kept between 59 °F and 77 °F (15 °C and 25 °C).

2.5.1 Storing Batteries for Delayed Installation

If the battery system will not be installed immediately, it must be stored indoors in a clean, dry, and cool location. Batteries should be unpacked, installed, and charged as soon as possible after delivery.

NOTICE

- Risk of failure to properly charge batteries. Can cause permanent damage to batteries and void the warranty.
- Batteries will self-discharge during storage. Batteries must be recharged as recommended by the battery manufacturer. A notice of **Charge Before Date** is affixed to each unit that has batteries inside. The **charge before date** is calculated based on the batteries being stored at 77 °F (25 °C). Storage at a higher temperature will increase the rate of self-discharge, requiring earlier recharge. Consult the battery manufacturer on how to determine when the batteries need to be recharged.

2.5.2 Installation Considerations

Position — Refer to APM2 Modular EBC manual or submittals for complete system line-up details. APM2 modular EBC design is located next to the right side of the UPS (120kVA 400V Frame). The front access design eliminates side and rear service clearance requirements. Refer to **Table 5.4** on page 31 and **Table 5.5** on page 32 for battery cabinet dimensions and weights.

Bolt-On Cabinets — Matching battery cabinets are designed to bolt only onto the right side or left side of the UPS module cabinet. Use bolts that ship with each unit to connect cabinet frames at posts, two places in the front and two places in the rear.

Service Clearance — Allow front access to the battery cabinet at all times for maintenance and service. Electrical codes require that the battery cabinet be installed with no less than 36 ft. (914mm) of clearance at the front of the cabinet when operating. No service clearance is required on either the side or rear. Clearance at the top of the cabinet is 24" (610mm).

Cables — Cables can be run between cabinets through cutouts in the cabinet sides, eliminating the need for external conduit runs. Route cables before moving the cabinets to their final location for bolting. Cables can also be accessed from the top if desired. Power terminals, auxiliary terminals blocks and circuit breakers are accessed from the front and top. Removable panels on the top are secured to the chassis by screws. The door can be opened to give access to the power connections bars, auxiliary terminal blocks and breakers. The front door can be opened 180° for easier service and more flexibility in installation.

Software — For the UPS to accurately display battery runtime, the number of battery modules, system voltage, and battery voltage must be noted during initial startup and setup using the configuration software. This is performed by the Vertiv engineer when commissioning the unit.

Casters and Adjustable leveling feet — The adjustable leveling feet are not designed to bear the full weight of the cabinet. Lower the stops until they are finger-tight in contact with the floor. Then tighten a small amount with a wrench (less than two turns) to give a good friction fit. When mounting the battery cabinet on seismic stands, ensure that the casters are bearing the weight of the cabinet.

2.6 Moving and Fixed installation

2.6.1 Moving the Battery Cabinets

The battery cabinets should be moved with a forklift or similar equipment. The battery cabinet has casters for movement over short distances. The bottoms of the battery cabinets are reinforced to permit lifting by forklift to move them longer distances. The bottom structure will support the unit only if the forks are completely beneath the unit.

The route between the point of arrival and the unit's installation location must be planned to make sure that all passages are wide enough for the unit and that floors will support its weight (for instance, check that doorways, lifts, or ramps, are big enough and that there are no impassable corners or changes in the level of corridors). Ensure that the cabinet weight is within the designated surface weight loading (kg/cm²) of any handling equipment. See **Table 5.1** on page 31 and **Table 5.5** on page 32 for weight details. Ensure that any lifting equipment used to move the battery equipment has sufficient lifting capacity. Because the weight distribution in the cabinet is not symmetrical, use extreme care during handling and transporting. When moving the unit by forklift, care must be taken to protect the panels. Handling the unit with straps is not authorized.



WARNING! Risk of heavy unit falling over. Improper handling can cause equipment damage, injury or death. Exercise extreme care when handling battery cabinets to avoid equipment damage or injury to personnel. The battery system cabinets weigh from 3000 lbs or 1362 kg, (empty cabinet is 816 lbs or 320 kg). Locate center of gravity symbols and determine the unit's weight before handling a cabinet. Test lift and balance the cabinets before moving them. Maintain minimum tilt from vertical at all times. Read all the instructions before attempting to move, lift, or remove packaging from unit, or prepare unit for installation.



AVERTISSEMENT! Risque de chute d'une unité lourde. Une mauvaise manipulation peut entraîner des dommages matériels, des blessures, voire la mort. Faites preuve d'une extrême prudence lors de la manipulation des armoires de batteries pour éviter d'endommager l'équipement ou de blesser le personnel. L'armoire de batterie (y compris les modules de batterie) pèse 3 000 lb ou 1 362 kg (l'armoire vide pèse 816 lb ou 320 kg). Localisez les symboles du centre de gravité et déterminez le poids de l'unité avant de manipuler une armoire. Testez le levage et l'équilibre des armoires avant de les déplacer. Maintenez à tout moment une inclinaison minimale par rapport à la verticale. Lisez toutes les instructions suivantes avant d'essayer de déplacer, de soulever ou de retirer l'emballage de l'unité, ou de préparer l'unité pour l'installation.

2.6.2 Raised-Floor Mounting

If the equipment is to be placed on a raised floor, it should be mounted on a pedestal suitably designed to accept the equipment point loading. Refer to the base view to design this pedestal.

Figure 2.6 Raised-Floor Mounting

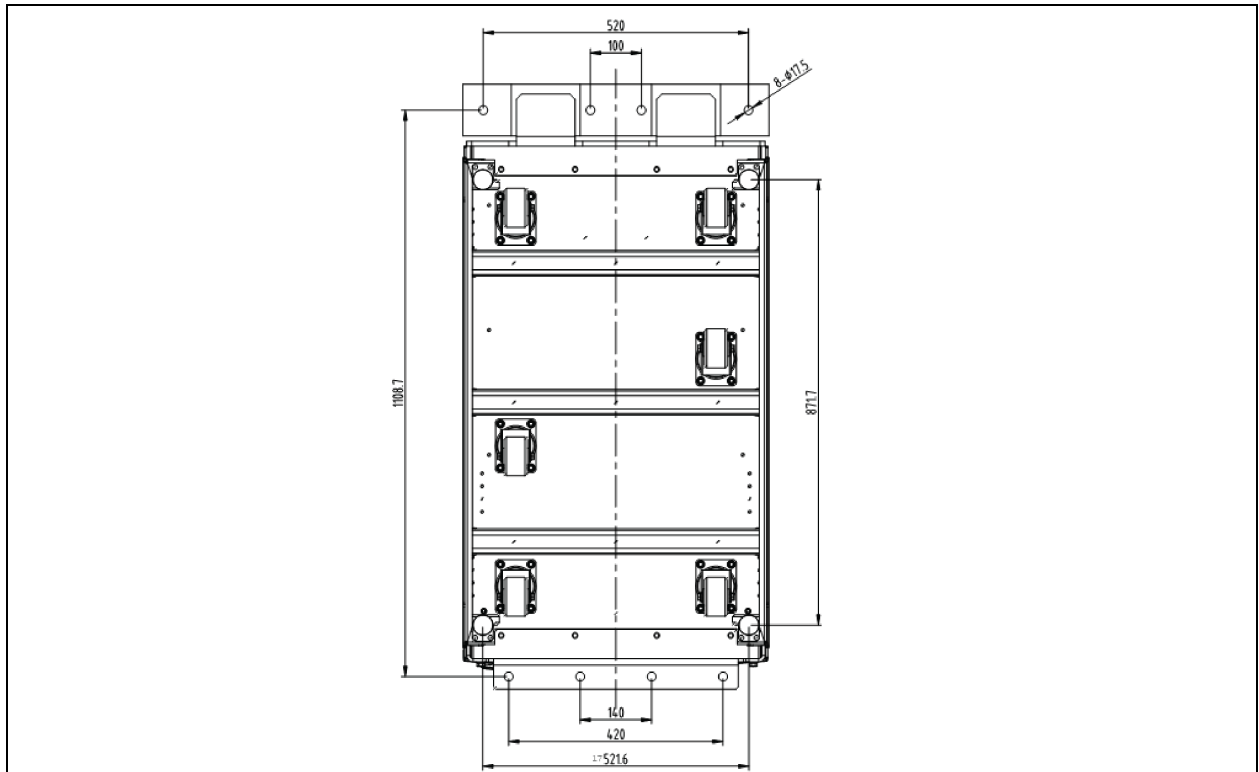

2.7 Layout

According to the design, The modular battery cabinet is placed on the right side of the UPS, as shown in **Figure 2.7** below.

Figure 2.7 Battery Cabinets Connected, Attached to UPS (Bolted Together)

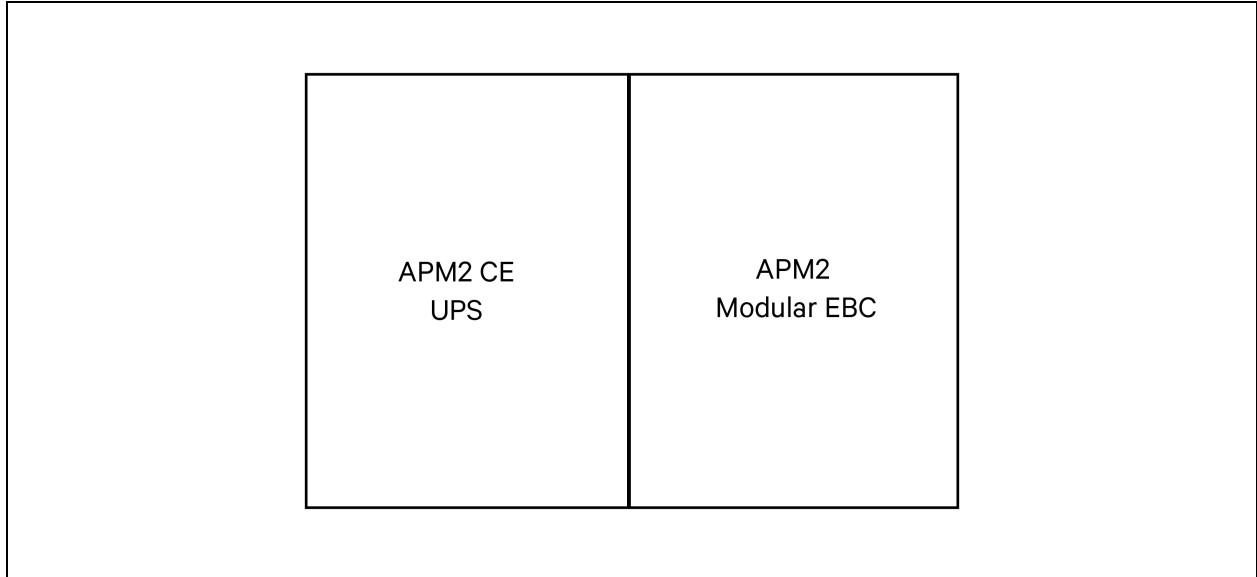

2.7.1 Connecting the Vertiv™ Liebert® APM2 Modular External Battery Cabinet to the UPS

After the battery cabinet equipment is in place and fixed, and the battery modules are installed, connect the power cables as follows.

1. Verify that all incoming high and low voltage power circuits are de-energized and locked out or tagged out before installing cables or making any electrical connections.
2. Removing the UPS and battery cabinet rear panels.
3. Remove the UPS and battery cabinet front panels to access the communication cables.
4. Connect the safety ground and any necessary bonding ground cables to the copper ground busbar. All cabinets in the UPS system must be connected to the user's ground connection.
5. Connect the system battery cables from the UPS battery terminals (+, -) to battery cabinet copper (+, -) as shown in **Figure 3.1** on page 21. Be sure that the battery connections are made with the right polarity, and tighten the connections to the torque specified in **Table 6.1** on page 36. Do not close the battery circuit breaker before the equipment has been commissioned.

2.7.2 Wiring Schematic

For the wiring schematic diagram of the modular battery cabinet and UPS, please refer to **Figure 3.1** on page 21.

This page intentionally left blank

3 Battery Module Installation

3.1 Safety

Special care should be taken when working with the batteries associated with the Vertiv™ Liebert® APM2 Modular EBC System equipment. When all the cells are connected together, the battery terminal voltage will exceed 192 or 384Vdc and is potentially lethal. A primary safety consideration is to install the battery equipment in an isolated area, accessible only to properly trained and qualified maintenance personnel.



WARNING! Risk of electrical shock and fire. Can cause equipment damage, personal injury, or death. Servicing of batteries should be performed or supervised by personnel knowledgeable of batteries and the required precautions. Keep unauthorized personnel away from batteries.

Lead-acid batteries can present a risk of fire because they generate hydrogen gas. In addition, the electrical connections must be protected against accidental short circuits which can cause sparks.

The following procedures should be followed:

- Do not smoke when near batteries.
- Do not cause flame or spark in battery area.
- Discharge static electricity from body before touching batteries by first touching a grounded metal surface.
- Replace the battery module in the battery cabinet and dispose of the replaced battery properly. It is not recommended that users repair the replaced battery module by themselves.



AVERTISSEMENT! Risque de décharge électrique et d'incendie. Pouvant entraîner des dommages matériels, des blessures et même la mort. Le remplacement des batteries doit être effectué ou supervisé par des membres du personnel dotés des compétences requises et connaissant les précautions à prendre. Le personnel non autorisé ne doit pas avoir accès aux batteries.

Les procédures suivantes doivent être suivies :

- NE FUMER PAS à proximité des batteries.
- NE PAS provoquer de flammes ou d'étincelles dans la zone de la batterie.
- Déchargez l'électricité statique du corps avant de toucher les batteries en touchant d'abord une surface métallique mise à la terre.
- Remplacez le module de batterie dans l'armoire à batterie et jetez la batterie remplacée de manière appropriée. Il n'est pas recommandé aux utilisateurs de réparer eux-mêmes le module de batterie remplacé.

NOTICE

Risk of equipment damage. Batteries should be cleaned with a dry cloth or a cloth lightly moistened with water. Do not use cleaners on the batteries. Solvents can make the battery cases brittle because individual battery characteristics are not identical and may change over time, the UPS module is equipped with circuitry to equalize battery cell voltages. This circuit increases charging voltage to maintain flooded type battery cells at full capacity.



WARNING! Risk of electric shock, explosive reaction, hazardous chemicals and fire. Can cause equipment damage, personal injury, and death. Do not use equalize charging with valve regulated, lead-acid batteries, such as those in Vertiv™ Liebert® APM2 Battery Cabinet. Refer to the battery manufacturer's manual, available on the manufacturer's website, for specific information about equalize charging.

The following general battery safety precautions and warnings must be observed at all times:

- A battery can present risk of electric shock or burn from high short circuit currents.
- When connected in a string, the voltage will exceed 288 VDC. This voltage is potentially lethal. Always observe high-voltage precautions.
- Eye protection must be worn to prevent injury from accidental electrical arcs.
- Remove rings, watches, necklaces, bracelets and all other metal objects.
- Use only tools with insulated handles.
- Wear appropriate personal protective equipment when handling batteries.
- If a battery leaks electrolyte or is otherwise physically damaged, it should be placed in a container resistant to wire and disposed of in accordance with local regulations.
- If electrolyte comes into contact with the skin, the affected area should be washed immediately with plenty of clean water.
- Batteries must always be disposed of according to local environmental laws.
- When replacing batteries, use the same number and type that were originally fitted.
- Disconnect charging source prior to connecting or disconnecting battery terminals.
- Determine if the battery is grounded. If it is grounded, remove source of ground. Contact with any part of a grounded battery can result in electrical shock.
- Battery support tray must be used whenever a battery tray is being pulled out.



AVERTISSEMENT! Risque de décharge électrique, de réaction explosive, d'incendie et d'exposition à des produits chimiques dangereux pouvant entraîner des dommages matériels, des blessures et même la mort. N'utilisez pas de charge d'égalisation avec des batteries d'accumulateurs au plomb à régulation par soupape, comme celles utilisées dans les armoires de batterie Liebert. Reportez-vous au manuel du fabricant des batteries, disponible sur le siteweb du fabricant, pour obtenir des renseignements précis sur la charge d'égalisation.

- Les précautions générales de sécurité et les avertissements suivants concernant la batterie doivent être respectés à tout moment :
- Une batterie peut présenter un risque de choc électrique ou de brûlure en raison de courants de court-circuit élevés.
- Lorsqu'il est connecté en chaîne, la tension dépassera 192 V CC. Cette tension est potentiellement mortelle. Respectez toujours les précautions relatives à la haute tension.
- Une protection oculaire doit être portée pour éviter les blessures causées par des arcs électriques accidentels.
- Retirez les bagues, montres, colliers, bracelets et tout autre objet métallique.
- Utilisez uniquement des outils dotés de poignées isolées.
- Portez un équipement de protection individuelle approprié lors de la manipulation des batteries.

- Si une batterie perd de l'électrolyte ou est physiquement endommagée, elle doit être placée dans un conteneur résistant aux fils et éliminée conformément aux réglementations locales.
- Si l'électrolyte entre en contact avec la peau, la zone affectée doit être immédiatement lavée avec beaucoup d'eau propre.
- Les batteries doivent toujours être éliminées conformément aux lois environnementales locales.
- Lors du remplacement des piles, utilisez le même numéro et le même type que ceux installés à l'origine.
- Débranchez la source de charge avant de connecter ou de déconnecter les bornes de la batterie.
- Déterminez si la batterie est mise à la terre. S'il est mis à la terre, supprimez la source de terre. Tout contact avec n'importe quelle partie d'une batterie mise à la terre peut entraîner un choc électrique.
- Le plateau de support de batterie doit être utilisé chaque fois qu'un plateau de batterie est retiré.

3.1.1 Connecting the Batteries

The Vertiv™ Liebert® APM2 modular EBC are mounted adjacent to each other on a solid floor, cables can be routed between cabinets through the sides or tops of the cabinets. Inter-tray connections must be made before using the battery cabinets.

3.1.2 Grounding

The ground cables and hardware will be supplied for cabinets ordered as connected or attached. The customer must supply the cables and hardware for detached and stand-alone cabinets. Size grounding conductor according to local codes. See terminal detail drawings for the location of the ground busbar.

3.2 Control Connection

Each APM2 Modular EBC contains a Lead-acid collection BMS and a Lead-acid collection backplane. See **Figure 3.2** on page 25. See **Figure 3.1** on page 21 for control wiring between the Vertiv™ Liebert® APM2 Modular EBC and the APM2 CE UPS.

3.3 Battery Module Information

The cell information and battery module information are as follows.

Battery Cell Information	
Supplier	LEOCH
Nominal Capacity	9AH
Voltage (V)	12V (6 cells per unit)
Part Number	DJW12-9.0
Weight lb. (kg)	2.66
Maximum Discharge Current	70A
Maximum Charge Current	2.7 A
Battery module information	
Rated voltage (V)	96 (8 batteries per unit)

Battery Cell Information	
Rated current	31.25A
Weight lb. (kg)	74.08(33.6)
Energy (Wh)	3000
Dimensions (mm)	87(H) X 210(W) X 720(D)

3.3.1 Floor Installation

If the APM2 Modular EBC is to be placed on a raised floor, the APM2 Modular EBC should be mounted on a pedestal that will support the equipment point loading. The mechanical stops are used to prevent the cabinet from rolling and should not be used for leveling or bearing the battery cabinet's weight.

3.3.2 Cable Entry

Cables can enter the APM2 Modular EBC through the bottom plastic seal or can be routed internally to the UPS.

These seals allow for routing of cables or conduit. Conduit size and routing methods must comply with all local, regional and national codes and regulations, including NEC ANSI/NFPA 70.

3.4 Wiring

3.4.1 Battery Cabinet Interface Connectors

The lead-acid battery collection BMS communicates by plugging in the backplane and battery module. The function definition of the backplane is shown in **Figure 3.3** on page 26, and the panel definition of the lead-acid collection module is shown in **Figure 3.2** on page 25, The connection diagram between the battery cabinet and the UPS is shown in **Figure 3.1** below.

Figure 3.1 Vertiv™ Liebert® APM2 EBC Connection to Vertiv™ Liebert® APM2 10 kVA to 120 kVA UPS

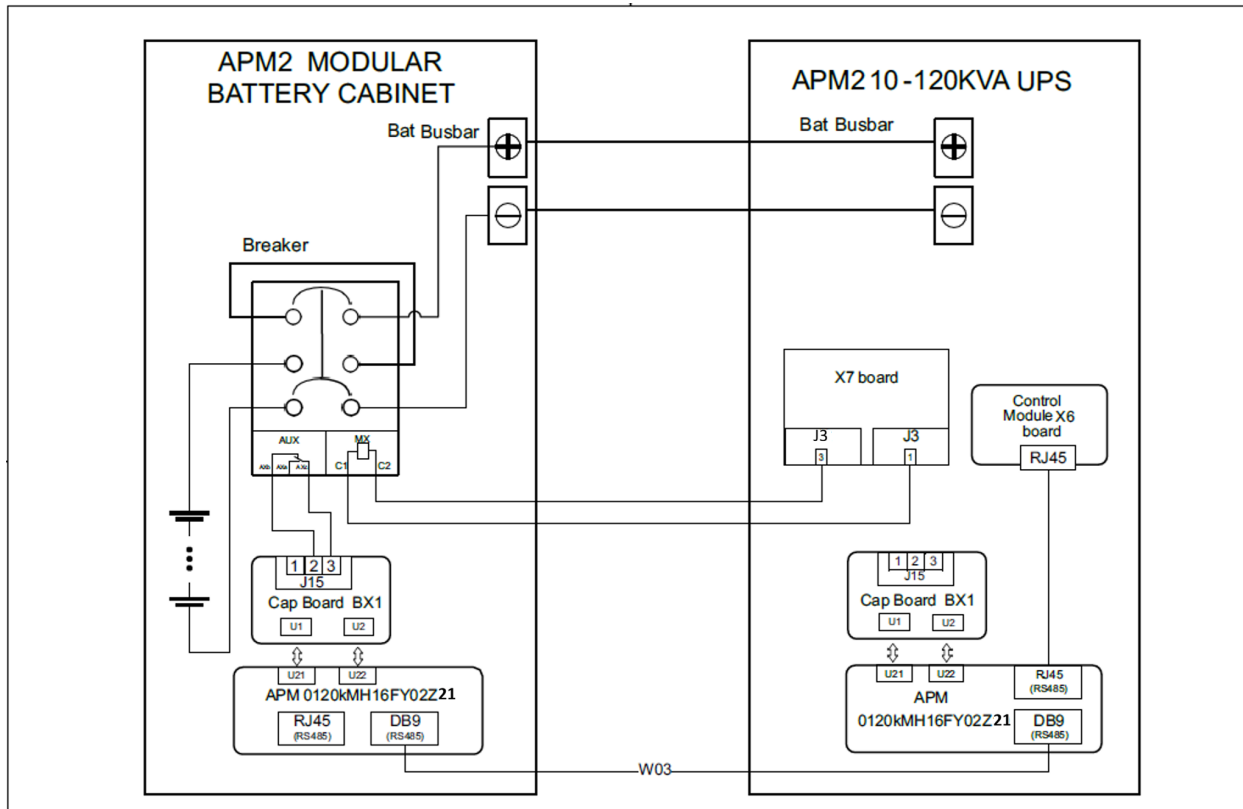

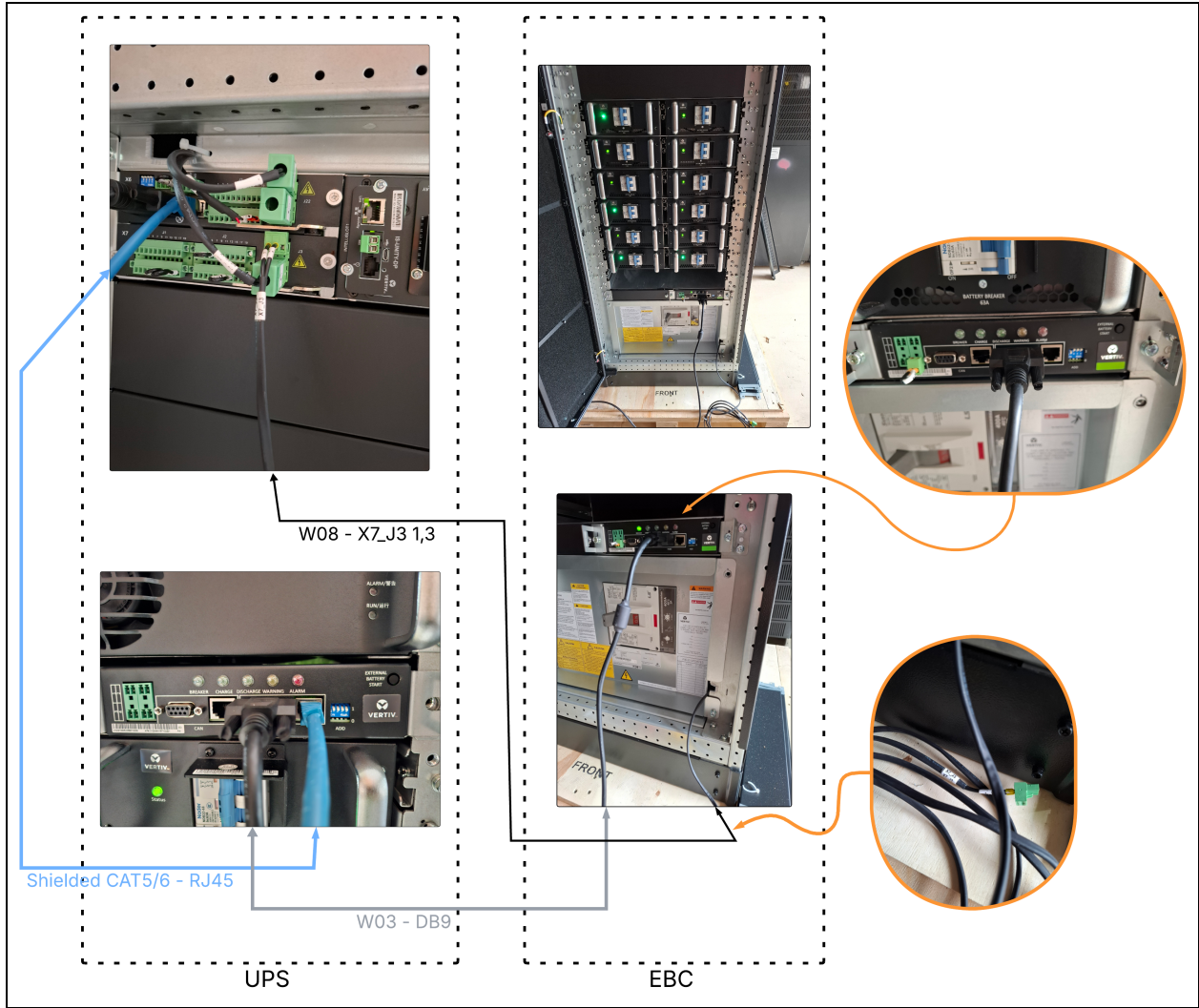

Table 3.1 Wiring for Vertiv™ Liebert® APM2 UPS to APM2 EBC

Liebert® APM2 CE EBC	APM2 CE FR1 UPS 400/120Kva
EBC BAT+Copper bar	UPS BAT+ Copper bar
EBC BAT- Copper bar	UPS BAT- Copper bar
Breaker_ Shunt release	FR1 X7_J3_1,3pin
EBC_ Battery detection module_RS485	FR1_ Battery detection module_RS485

Although the individual battery cells are sealed (valve regulated) and require only minimal maintenance, the Battery Cabinets should be given a periodic inspection and electrical check. Checks should be performed at least annually to ensure years of trouble-free service.

Voltage records: With the battery cabinet DC circuit breaker closed and the connected UPS operating, measure and record battery float voltage. With the DC circuit breaker open, measure and record the nominal (open circuit) voltage. Both these measurements should be made across the final positive and negative terminal lugs. Compare these values with those shown below. The recorded nominal voltage should be no less than the value shown; while the recorded float voltage should be within the range shown. If a discrepancy is found, contact Vertiv.

Table 3.2 Battery Voltage, Rated Voltage, and Float Voltage

APM2 Modular EBC			
rated voltage	Number of Cells	Equalizing charging voltage	Float Voltage
384Vdc	192	451.2Vdc	435.8Vdc



WARNING! Risk of heavy unit tipping over while being moved. Can cause property damage, injury and death. The casters are strong enough for movement across even surfaces only. Casters may fail if they are subjected to shock loading, such as being dropped or rolled over holes in the floor or obstructions. Such failure may cause the unit to tip over, injuring personnel and damaging the equipment.



AVERTISSEMENT! Risque de renversement de l'unité lourde lors de son déplacement. Peut causer des dommages matériels, des blessures, voire la mort. Les roulettes sont suffisamment solides pour se déplacer uniquement sur des surfaces planes. Les roulettes peuvent tomber en panne si elles sont soumises à des chocs, comme une chute ou un retournement sur des trous dans le sol ou des obstructions. Une telle défaillance pourrait faire basculer l'unité, blessant le personnel et endommageant l'équipement.

When replacing batteries, use the same number and type of batteries.



WARNING! Risk of electrical shock. Can cause personal injury and death. Check for voltage with both AC and DC voltmeters before working within the EBC. Check for voltage with both AC and DC voltmeters before making contact. Only properly trained and qualified personnel wearing appropriate safety headgear, gloves, shoes, and glasses should be involved in installing the EBC or preparing the EBC for installation. When performing maintenance with any part of the equipment under power, service personnel and test equipment should be standing on rubber mats. Lead-acid batteries contain hazardous materials. Batteries must be handled, transported, and recycled or discarded in accordance with federal, state and local regulations. Because lead is a toxic substance, lead-acid batteries must be recycled rather than discarded. Do not dispose of battery or batteries in a fire. The battery may explode. Do not open or mutilate the battery or batteries. Released electrolyte is harmful to the skin and eyes. It is toxic.

The following precautions must be observed when working on batteries:

- Remove watches, rings and other metal objects.
- Use tools with insulated handles.
- Wear rubber gloves and boots.
- Do not lay tools or metal parts on top of batteries.
- Disconnect charging source prior to connecting or disconnecting battery terminals.
- Determine whether the battery is grounded. If it is grounded, remove source of ground. Contact with any part of a grounded battery can result in electrical shock. The likelihood of such shock will be reduced if such grounds are removed during installation and maintenance.



AVERTISSEMENT! Risque de choc électrique. Peut causer des blessures corporelles, voire la mort. Vérifiez la tension avec les voltmètres AC et DC avant de travailler dans l'EBC. Vérifiez la tension avec les voltmètres AC et DC avant de prendre contact. Seul le personnel correctement formé et qualifié portant un casque de sécurité, des gants, des chaussures et des lunettes appropriés doit être impliqué dans l'installation de l'EBC ou dans la préparation de l'EBC pour l'installation. Lors de l'exécution d'une maintenance avec une partie de l'équipement sous tension, le personnel d'entretien et l'équipement de test doivent se tenir debout sur des tapis en caoutchouc. Les batteries au plomb contiennent des matières dangereuses. Les batteries doivent être manipulées, transportées et recyclées ou jetées conformément aux réglementations fédérales, étatiques et locales. Le plomb étant une substance toxique, les batteries au plomb doivent être recyclées plutôt que jetées. Ne jetez pas la ou les piles dans le feu. La batterie pourrait exploser. N'ouvrez pas et ne mutiliez pas la ou les piles. L'électrolyte libéré est nocif pour la peau et les yeux. C'est toxique.

Lorsque vous travaillez avec des batteries, prenez les précautions suivantes :

- Retirez montre, bagues et tout autre objet métallique.
- Utilisez des outils dont le manche est isolé.
- Portez des gants et des bottes de caoutchouc.
- Ne posez aucun outil ni pièce métallique sur le dessus d'une batterie.
- Déconnectez la source de chargement avant de brancher ou de débrancher les bornes d'une batterie.
- Vérifiez si la batterie est mise à la terre. Le cas échéant, éliminez la cause de la mise à la terre.
- Le contact avec toute partie d'une batterie mise à la terre peut provoquer une décharge électrique. Pour réduire de tels risques d'accident, débranchez les prises de terre avant de procéder à l'installation ou à l'entretien.

3.5 Vertiv™ Liebert® APM2 Modular EBC Monitoring System

Figure 3.2 Liebert® Lead-acid Acquisition Module Monitoring System

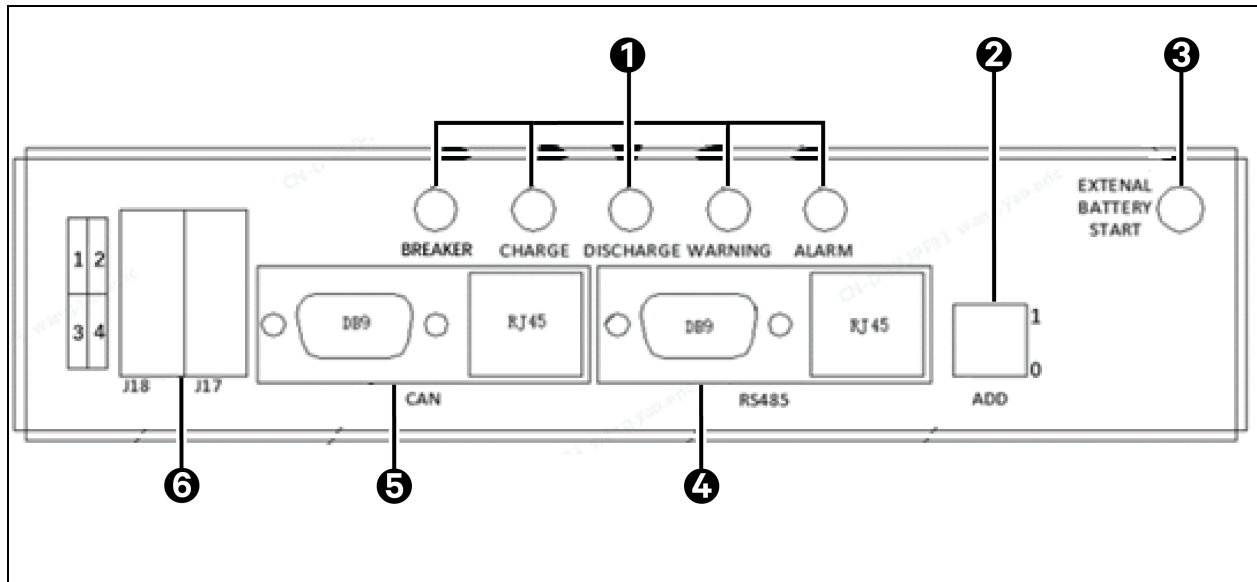
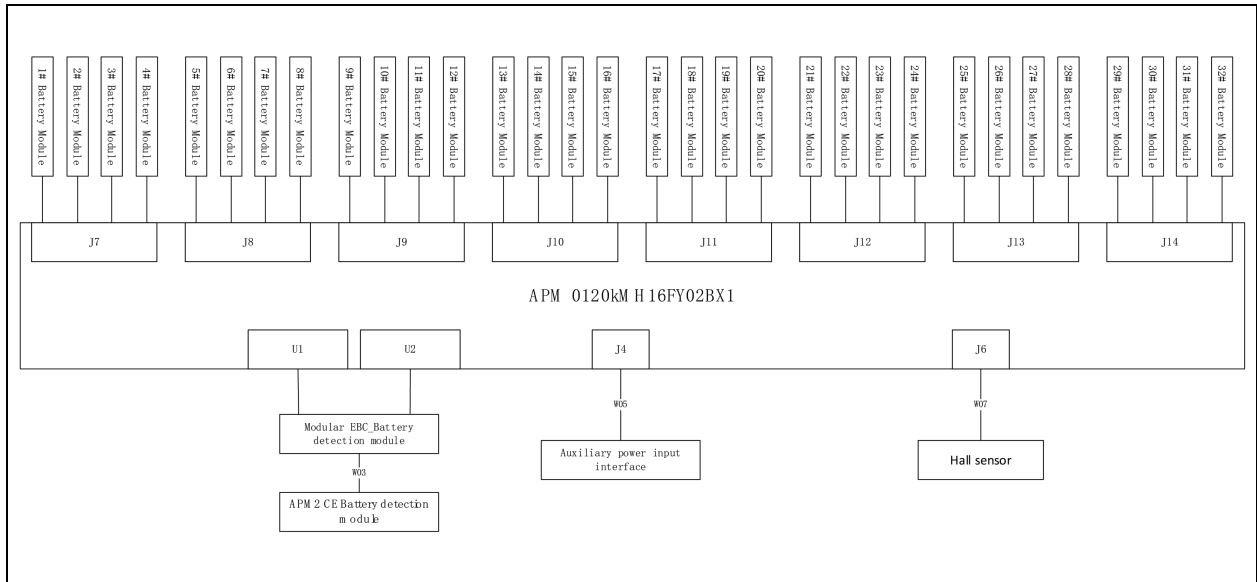

Table 3.3 Interface description

Number	Name	Function
1	BMS indicator light	<p>Breaker: The light flashes, indicating that the main circuit breaker is closed. constant indicates closed. The light is always on, indicating that the main circuit breaker is closed.</p> <p>Charge and discharge: retain the display function.</p> <p>Warning: lead-acid collection system abnormality.</p> <p>Alarm: lead-acid collection system failure.</p>
2	DIP switch	UPS identifies which EBC through this DIP switch number (APM2 Modular EBC : 0111)
3	Lead-acid BMS start button	Push the button and the lead-acid acquisition BMS will work.
4	485 communication	EBC communicates with UPS through 485.
5	CAN communication	Reserve
6	Dry contact	There are four dry contacts, one for BCB online and the other three for reservation.

APM2 Modular EBC installing an battery monitoring system(Lead Acid Collection BMS) inside the cabinet. The monitoring system continuously checks battery parameters, such as overall string voltage, current and temperature. Automatic periodic tests of battery will verify the battery's operating integrity. Connect the BMS according to **Figure 3.3** on the next page.

Figure 3.3 BMS Connection



3.6 Circuit Breaker Control Cable Wiring

The circuit breaker control cable includes the circuit breaker and auxiliary contact cable. The shunt tripping realizes the circuit breaker tripping control, and the auxiliary contact feeds back the circuit breaker switch status. The wiring refers to Figure 3.2 on the previous page.

Table 3.4 EBC Circuit Breaker Schedule

Battery Cabinet	Amp Frame (AF) /Amp Trip (AT)	IR Setting	LI Setting	MFG
120KVA 400 600mm Modular EBC	400/400	320	2000	LS

3.7 Battery Protection

3.7.1 Battery Low-Voltage Warning

Before the end of discharge, the APM2 CE UPS displays a low battery warning. The APM2 CE can be user-configured to display this warning from 2 to 60 minutes before end-of discharge.

3.7.2 Battery End of Discharge Protection

If the battery voltage is lower than the end-of-discharge voltage, the battery converter will be shut down.

3.8 Vertiv™ Liebert® APM2 EBC Backup Times

The modular battery cabinet and the built-in battery of the UPS cabinet supply power to the load together. The backup time is calculated based on the entire system.

3.8.1 The Backup Time

The backup time is given in the **Table 3.5** below, 4 modules for 400V&120kw.

Table 3.5 CE Modular EBC 400V&120K

Backup Time BOL (min)												
Module count	Output Load (KW)											
	10	20	30	40	50	60	70	80	90	100	110	120
4	6	/	/	/	/	/	/	/	/	/	/	/
8	19	6	/	/	/	/	/	/	/	/	/	/
12	32	13	6	/	/	/	/	/	/	/	/	/
16	46	19	11	6	/	/	/	/	/	/	/	/
20	60	26	15	10	6	5	/	/	/	/	/	/
24	72	32	19	13	9	6	5	/	/	/	/	/
28	80	40	24	16	12	8	6	5	/	/	/	/
32	86	46	28	19	14	11	8	6	5	/	/	/

3.8.2 Battery Cabinet Energy

Depending on the number of battery modules installed in the cabinet, the energy contained is shown in the following **Table 3.6** below.

Table 3.6 Modular EBC 400V&120K

Main Cabinet Battery Parameters				
Modules	Voltage (V)	capacity (AH)	Power (Wh)	Rated current
4	384	9	3456	31.25
8	384	18	6912	62.5
12	384	27	10368	93.75
16	384	36	13824	125
20	384	45	17280	156.25
24	384	54	20736	187.5
28	384	63	24192	218.75
32	384	72	27648	250

This page intentionally left blank

4 Installation Drawings

4.1 Cabinet Installation Diagram

For installation drawings, please refer to [Battery Cabinet Installed](#) on page 6 , which contains detailed cabinet installation drawings and battery module installation guidelines.

4.2 System Inspection and Power-on

4.2.1 Preparation before Power-on

1. Insert the lead-acid battery module correctly into the chassis and tighten the screws.
2. The main circuit breaker (MCCB) is in the disconnected position.
3. The positive and negative poles of the power output cable are connected correctly, and the communication line is connected correctly.
4. Wear personal protective measures.

4.2.2 Power on Steps

1. Close the panel miniature circuit breaker (MCB) of a group (4 lead-acid battery modules) of lead-acid battery modules, press [STAT] of the lead-acid acquisition module (BMS), and the panel light of the lead-acid battery module is always on;
2. Close the main circuit breaker;
3. Close the panel switches of the remaining lead-acid battery modules, and the panel lights of all lead-acid battery modules are always on.

4.2.3 Shutdown Steps

1. Disconnect the main circuit breaker;
2. Disconnect the panel switch of the lead-acid battery module, and the shutdown is completed.

4.3 Battery Module Maintenance

If a module fails during operation, it can be replaced without power outage. Before replacement, take personal safety precautions. The battery module supports hot-swap function, but the panel switch of the lead-acid module that needs maintenance needs to be powered off.

For 400V&120KW models, at most Four battery module circuit breaker can be disconnected at a time (four battery modules in this model are one string):

After the replacement is completed, close all module panel circuit breakers in turn.

This page intentionally left blank

5 Specifications

Table 5.1 Physical Standards and Parameters

Battery Cabinet Parameters	Values
Standard Color	Black (ZP-7021)
Front Door Opening (for serviceability)	180 degrees
Degree of Protection for EBC Enclosure	IP 20 (with and without front door open)
Minimum Clearance, Top	24 in. (610 mm)
Minimum Clearance, Back	0 in.
Minimum Clearance, Sides	
Cable Entrance	Top or Bottom
Standards and Conformities	/
Storage Temperature Range, °F (°C)	-13 to 158 (-25 to 70) 68 °F to 77 °F (20 °C to 25 °C) for optimal battery life
Operating Temperature Range, °F (°C)	32 to 104 (0 to 40) 68 °F to 77 °F (20 °C to 25 °C) for optimal battery life
Relative Humidity	Up to 95% Non-Condensing (Operating and Non-Operating)
Maximum Altitude Above MSL, ft. (mm)	4920 (1500) (as per IEC 62040/3) - 1% Maximum kW derate per 100 m rise between 1500 m to 3000 m

Table 5.2 Battery Cabinet System — Vertiv™ Liebert® CE UPS and Vertiv™ Liebert® APM2 Modular External Battery Cabinet

UPS Rating kVA	Maximum Battery Current (A)	Copper Wire	Bolt Size (in.)
CE-120	300A	120mm ²	M8

Table 5.3 Battery Short Circuit Current

Rated voltage	Part	Number of parallel battery modules	Short Circuit Current
384V	DJW12-9	8	3600 (A)

Table 5.4 APM2 Modular EBC Battery Parameters

Parameters	Values
Battery Rated Voltage	384 V
Number of Lead-Acid Cells	192 (32×6)
Float Voltage	2.27 V/cell, selectable from 2.25 to 2.3 V/cell
Temperature Compensation	-18.0mV/°C

Table 5.5 Liebert® APM2 Modular EBC CE Mechanical Characteristics

Parameters	Values
Dimensions, W x D x H, in(mm)	23.71x 36.44 x 78.82(602.4 x 925.7 x 2002.7)
Total Weight, lb (kg)	2892 (1312Kg)
Only cabinet	705 (320KG)
Color	ZP-7021 (Black)
Protection Degree IEC(60529)	IP20 (finger-proof with front doors open or closed)

6 Maintenance

Become thoroughly familiar with the equipment, but at no time go beyond the specific procedures in this manual while performing maintenance or correcting a malfunction. In case of doubt, call Vertiv for further instructions. The EBC is designed for unattended operation, but does require some basic maintenance.

- Keep good records. Troubleshooting is easier if you maintain historical service records.
- Keep the EBC free of dust and any moisture.
- Keep the EBC cool.
- Battery systems must be kept in the range of 72 °F to 77 °F (22 °C to 25 °C) in order to meet design specifications for capacity and longevity.
- The UPS will reliably meet all performance specifications at temperatures up to 104 °F (40 °C), and can be slightly derated for operation at even higher temperatures. However, performance and longevity will be optimized when the UPS is operated at the same temperature as the batteries.
- Keep connections tight.
- Tighten all connections at installation and at least annually thereafter. See [Torque Requirements](#) on page 35 for more details.

6.1 Record Log

Set up a maintenance log to record scheduled checks and any abnormal conditions. The log should have space for all metered data including phase readings, alarm messages, UPS mode of operation, air filter replacement date and observation notes. A second log should be maintained for the battery module as directed by the battery manufacturer.

Vertiv recommends a periodic inspection of the UPS and battery rooms to check for visible and audible indications of problems. Log the inspection, metered parameter indications and any discrepancies.

6.2 Battery Maintenance



WARNING! Risk of electrical shock and arc flash. Can cause property damage, injury and death. These maintenance procedures will expose hazardous live parts. Refer servicing to properly trained and qualified personnel.



AVERTISSEMENT! Risque de choc électrique et d'arc électrique. Peut causer des dommages matériels, des blessures, voire la mort. Les procédures d'entretien ci-dessous exposent des composants sous tension dangereuse. Les interventions d'entretien doivent être confiées à du personnel qualifié et dûment formé.

6.3 Battery Safety Precautions

Servicing of batteries should be performed or supervised by personnel experienced with batteries and the required precautions. Keep unauthorized personnel away from batteries. When replacing batteries, use the same number and type of batteries.



WARNING! Risk of electrical shock. Can cause personal injury and death. Check for voltage with both AC and DC voltmeters before working within the EBC. Check for voltage with both AC and DC voltmeters before making contact. Only properly trained and qualified personnel wearing appropriate safety headgear, gloves, shoes and glasses should be involved in installing the EBC or preparing the EBC for installation. When performing maintenance with any part of the equipment under power, service personnel and test equipment should be standing on rubber mats. Lead-acid batteries contain hazardous materials. Batteries must be handled, transported and recycled or discarded in accordance with federal, state and local regulations. Because lead is a toxic substance, lead-acid batteries must be recycled rather than discarded. Do not dispose of battery or batteries in a fire. The battery may explode. Do not open or mutilate the battery or batteries. Released electrolyte is harmful to the skin and eyes. It is toxic.

The following precautions must be observed when working on batteries:

- Remove watches, rings, and other metal objects.
- Use tools with insulated handles.
- Wear rubber gloves and boots.
- Do not lay tools or metal parts on top of batteries.
- Disconnect charging source prior to connecting or disconnecting battery terminals.
- Determine whether the battery is grounded. If it is grounded, remove source of ground. Contact with any part of a grounded battery can result in electrical shock. The likelihood of such shock will be reduced if such grounds are removed during installation and maintenance.

Since individual battery characteristics are not identical and may change over time, the UPS module is equipped with circuitry to equalize battery cell voltages. This circuit temporarily increases charging voltage to maintain flooded type battery cells at full capacity. According to the [Torque Requirements](#) on the facing page All electrical connections must be tight. **Table 6.1** on page 36 and **Table 6.2** on page 36 provide the torque values for the connections in the UPS and batteries. Use these values unless the equipment is labeled otherwise.



AVERTISSEMENT! Risque de choc électrique. Peut causer des blessures corporelles, voire la mort. Vérifiez la tension avec les voltmètres AC et DC avant de travailler dans l'EBC. Vérifiez la tension avec les voltmètres AC et DC avant de prendre contact. Seul le personnel correctement formé et qualifié portant un casque de sécurité, des gants, des chaussures et des lunettes appropriés doit être impliqué dans l'installation de l'EBC ou dans la préparation de l'EBC pour l'installation. Lors de l'exécution d'une maintenance avec une partie de l'équipement sous tension, le personnel d'entretien et l'équipement de test doivent se tenir debout sur des tapis en caoutchouc. Les batteries au plomb contiennent des matières dangereuses. Les batteries doivent être manipulées, transportées et recyclées ou jetées conformément aux réglementations fédérales, étatiques et locales. Le plomb étant une substance toxique, les batteries au plomb doivent être recyclées plutôt que jetées. Ne jetez pas la ou les piles dans le feu. La batterie pourrait exploser. N'ouvrez pas et ne mutiliez pas la ou les piles. L'électrolyte libéré est nocif pour la peau et les yeux. C'est toxique.

Les précautions suivantes doivent être respectées lors de travaux sur des batteries :

- Retirez les montres, bagues et autres objets métalliques.
- Utilisez des outils avec des poignées isolées.
- Portez des gants et des bottes en caoutchouc.
- Ne posez pas d'outils ou de pièces métalliques sur les batteries.
- Débranchez la source de charge avant de connecter ou de déconnecter les bornes de la batterie.

- Déterminez si la batterie est mise à la terre. S'il est mis à la terre, supprimez la source de terre. Tout contact avec n'importe quelle partie d'une batterie mise à la terre peut entraîner un choc électrique. La probabilité d'un tel choc sera réduite si ces mises à la terre sont retirées lors de l'installation et de la maintenance.

Étant donné que les caractéristiques individuelles des batteries ne sont pas identiques et peuvent changer avec le temps, le module UPS est équipé de circuits pour égaliser les tensions des cellules de la batterie. Ce circuit augmente temporairement la tension de charge pour maintenir les cellules de batterie de type inondé à pleine capacité. [Torque Requirements](#) on page 1 Exigences de couple Toutes les connexions électriques doivent être serrées. Les tableaux **Table 1.1** on page 1, **Table 6.2** on the next page fournissent les valeurs de couple pour les connexions de l'onduleur et des batteries. Utilisez ces valeurs, sauf si l'équipement est étiqueté autrement.

Regular maintenance of the battery module is an absolute necessity. Periodic inspections of battery and terminal voltages, specific gravity, and connection resistance should be made. Strictly follow the procedures outlined in the battery manufacturer's manual. (See battery manufacturer's website.)

valve regulated lead-acid batteries do require periodic maintenance. Although they do not require maintenance of electrolyte levels, visual inspections and checks of battery voltage and connection resistance should be made.

NOTICE

Risk of damaging battery cases. can cause breakage and leaking electrolyte.

Do not use cleaners on the batteries. Solvents can make the battery cases brittle. Use only a dry cloth or a cloth moistened with water.

Since individual battery characteristics are not identical and may change over time, the UPS module is equipped with circuitry to equalize battery cell voltages. This circuit temporarily increases charging voltage to maintain flooded type battery cells at full capacity.



WARNING! Risk of electric shock, explosive reaction, hazardous chemicals and fire. Can cause equipment damage, personal injury and death. Do not use equalize charging with valve regulated, lead-acid batteries, such as those used in APM2 CE EBC. Refer to the battery manufacturer's manual, available on the manufacturer's website, for specific information about equalize charging.



AVERTISSEMENT! Risque de choc électrique, de réaction explosive, de produits chimiques dangereux et d'incendie. Peut causer des dommages matériels, des blessures corporelles, voire la mort. N'utilisez pas de charge d'égalisation avec des batteries au plomb à régulation par valve, telles que celles utilisées dans l'APM2 Modular CE EBC. Reportez-vous au manuel du fabricant de la batterie, disponible sur le site Web du fabricant, pour obtenir des informations spécifiques sur l'égalisation de la charge.

6.4 Torque Requirements

All electrical connections must be tight.

Table 6.1 on the next page through **6.4** above provide the torque values for the connections in the UPS and batteries. Use these values unless the equipment is labeled otherwise.

Table 6.1 Busbars (for Power Wiring)

Bolt Shaft Size in Inch	lb-in	Nm
M12	309 to 389	35 to 44
M10	177 to 221	20 to 25
M8	88 to 106	10 to 12
M4	12 to 16	1.4 to 1.8

Table 6.2 Terminal Block with Compression Lugs (for Control Wiring)

Wire Size or Range (AWG)	lb-in	Nm
22AWG-14AWG	3.5 to 5.3	0.4 to 0.6

Appendices

Appendix A: Technical Support and Contacts

A.1 Technical Support/Service in the United States

Vertiv Group Corporation

24x7 dispatch of technicians for all products.

1-800-543-2378

Liebert® Thermal Management Products

1-800-543-2778

Liebert® Channel Products

1-800-222-5877

Liebert® AC and DC Power Products

1-800-543-2378

A.2 Locations

United States

Vertiv Headquarters

505 N Cleveland Ave

Westerville, OH, 43082, USA

Europe

Via Leonardo Da Vinci 8 Zona Industriale Tognana

35028 Piove Di Sacco (PD) Italy

Asia

7/F, Dah Sing Financial Centre

3108 Gloucester Road, Wanchai

Hong Kong

This page intentionally left blank

Connect with Vertiv on Social Media



<https://www.facebook.com/vertiv/>



<https://www.instagram.com/vertiv/>



<https://www.linkedin.com/company/vertiv/>



<https://www.x.com/Vertiv/>



Vertiv.com | Vertiv Headquarters, 505 N Cleveland Ave, Westerville, OH 43082 USA

©2026 Vertiv Group Corp. All rights reserved. Vertiv™ and the Vertiv logo are trademarks or registered trademarks of Vertiv Group Corp. All other names and logos referred to are trade names, trademarks or registered trademarks of their respective owners. While every precaution has been taken to ensure accuracy and completeness here, Vertiv Group Corp. assumes no responsibility, and disclaims all liability, for damages resulting from use of this information or for any errors or omissions.

SL-80124_REVB_02-26