



PowerUPS 9000 1250 kVA 415 V Modular UPS (UL)

User Manual

625 kVA to 1250 kVA, 415 V, 4-Wire, 50/60 Hz

The information contained in this document is subject to change without notice and may not be suitable for all applications. While every precaution has been taken to ensure the accuracy and completeness of this document, Vertiv assumes no responsibility and disclaims all liability for damages result from use of this information or for any errors or omissions.

Refer to local regulations and building codes relating to the application, installation, and operation of this product. The consulting engineer, installer, and/or end user is responsible for compliance with all applicable laws and regulations relation to the application, installation, and operation of this product.

The products covered by this instruction manual are manufactured and/or sold by Vertiv. This document is the property of Vertiv and contains confidential and proprietary information owned by Vertiv. Any copying, use, or disclosure of it without the written permission of Vertiv is strictly prohibited.

Names of companies and products are trademarks or registered trademarks of the respective companies. Any questions regarding usage of trademark names should be directed to the original manufacturer.

Technical Support Site

If you encounter any installation or operational issues with your product, check the pertinent section of this manual to see if the issue can be resolved by following outlined procedures.

Visit <https://www.vertiv.com/en-us/support/> for additional assistance.

TABLE OF CONTENTS

1 Important Safety Instructions	1
1.1 Glossary of Symbols	5
2 Overview	7
2.1 Introduction	7
2.2 Features	7
2.3 Control and Display Panel	7
2.4 Operation Modes	8
2.4.1 Normal Mode	8
2.4.2 Battery Mode	9
2.4.3 Automatic Restart Mode	10
2.4.4 Bypass Mode	10
2.4.5 ECO Mode	11
2.4.6 Frequency Converter Mode	12
2.4.7 Dynamic Online Mode	12
2.4.8 Parallel Mode (System Expansion)	12
2.4.9 Load Bus Synchronization Mode	13
2.5 Battery Management System	13
2.5.1 Normal Function	13
2.5.2 Advanced Functions	14
2.5.3 Battery Temperature Compensation	14
2.6 Battery Protection	14
2.6.1 Battery Low Pre-warning	15
2.6.2 EOD Protection	15
2.6.3 Battery Circuit Breaker Alarm	15
2.7 Parallel System and Load Bus Synchronization System	15
2.7.1 Parallel System	15
2.7.2 Parallel System Requirements	15
2.7.3 Load Bus Synchronization System	15
3 Mechanical Installation	17
3.1 Precautions	17
3.2 Transportation	18
3.3 Tools	20
3.4 Unpacking	21
3.5 Pre-installation Inspection	22
3.6 Environmental Requirement	23
3.6.1 UPS Location Selection	23
3.6.2 Battery Location Selection	23
3.6.3 Storage	24

3.7 Mechanical Requirement	24
3.7.1 Composition	24
3.7.2 Moving the Cabinet	24
3.7.3 Clearance	25
3.7.4 Cable Access	25
3.8 Installation	26
3.9 Module Components Introduction	27
3.9.1 Power Module Components	27
3.9.2 Bypass Module Component	28
3.9.3 Bypass Control Module Component	28
3.9.4 Control Module Component	29
3.10 Installation Drawings	30
4 Electrical Installation	31
4.1 Power Cable Wiring	31
4.1.1 System Configuration	31
4.1.2 Maximum Steady State AC and DC Currents	32
4.1.3 Recommended Cross-section Area of UPS Cable	33
4.1.4 Recommended Breaker of UPS OPD	39
4.1.5 General Information	39
4.1.6 Power Cable Connecting Terminal	40
4.1.7 Protective Ground	40
4.1.8 External Protective Devices	40
4.1.9 Power Cable Connection Steps	42
4.2 Wiring of Signal Cable	48
4.2.1 Overview	48
4.2.2 Input/Output Dry Contact Port X6 J3	49
4.2.3 Input/Output Dry Contact Port X7 J1	52
4.2.4 Input/Output Dry Contact Port X7 J2	53
4.2.5 Input/Output Dry Contact Port X7 J3	54
4.2.6 Remote Emergency Power Off Port	55
4.2.7 Parallel and Load Bus Synchronization Communication Ports	56
4.2.8 Vertiv™ Liebert® IntelliSlot™ Port	56
4.2.9 Signal Cable Connection Steps	56
5 Operator Control and Display Panel	59
5.1 Introduction	59
5.2 Navigating through the Vertiv™ PowerUPS 9000 1250 kVA 415 V Modular UPS Touchscreen	59
5.2.1 Vertiv™ PowerUPS 9000 1250 kVA 415 V Modular UPS Touchscreen Control Panel Components	60
5.3 Operation	61
5.3.1 Login	61
5.3.2 Operator Controls	63

5.4 Viewing UPS Status	68
5.4.1 Status Bar Component	68
5.4.2 Viewing UPS Data with the Status Gauge	70
5.4.3 Viewing UPS Data with the Status Panel	70
5.4.4 Logs Alarms and Events	73
6 Single UPS Operation	75
6.1 Introduction	75
6.2 UPS Start-up Procedures	75
6.2.1 Start-up Procedures in Normal Mode	76
6.2.2 Start-up Procedures in Economic Mode	79
6.3 Procedures for Transfer Between Operation Modes	80
6.3.1 Transfer from Normal Mode to Battery Mode	80
6.3.2 Transfer from Normal Mode to Bypass Mode	80
6.3.3 Transfer from Bypass Mode to Normal Mode	81
6.4 Battery Test Procedures	82
6.5 UPS Shutdown Procedures	84
6.5.1 Procedures to Completely Power Down the UPS	84
6.6 Emergency Power Off Procedures	84
6.7 UPS Reset Procedures after Emergency Power Off	85
6.8 Automatic Restart	85
7 Battery	87
7.1 Introduction	87
7.2 Safety	87
7.2.1 Safety Precautions	88
7.3 UPS Battery	89
7.4 Precautions for Installation Design	89
7.5 Battery Installation Environment and Number of Batteries	90
7.5.1 Installation Environment	90
7.6 Battery Protection	91
7.7 Battery Installation and Connection	91
7.8 Other External Battery	92
7.8.1 VRLA Battery Cabinet	92
7.8.2 Ni-Cd battery cabinet	92
7.8.3 Lithium Ion Battery Cabinet	92
7.8.4 UL 9540 Compliance	93
7.9 Battery Ground Fault Detector	95
7.10 Power Supply Units for Battery Interface Board	96
7.11 SAMSUNG and ZINC-FIVE Battery BMS Power Supply	98
8 Parallel System and Load Bus Synchronization System	101
8.1 General	101

8.2 System Installation Procedures	101
8.2.1 Preliminary Checks	101
8.2.2 Cabinet Installation	102
8.2.3 External Protective Device	103
8.2.4 Power Cable	103
8.2.5 Parallel Cable	103
8.2.6 Remote Emergency Power Off	105
8.3 Operation Procedures for Parallel System	106
8.3.1 Start-up Procedures in Normal Mode	106
8.3.2 Procedures for Isolating One UPS Module from Parallel System	106
8.3.3 Adding a Single Module UPS to a Parallel System Supporting Load	107
8.3.4 Procedures for Completely Powering Down a Multi-Module UPS System	107
8.4 Load Bus Synchronization System	108
8.4.1 Cabinet Installation	108
8.4.2 External Protective Device	109
8.4.3 Power Cable	109
8.4.4 Load Bus Synchronization Cable	110
9 Vertiv™ PowerUPS 9000 1250 kVA 415 V Modular UPS Option Configurations	113
9.1 Options List	113
9.2 Options Introduction	113
9.2.1 Seismic Anchor Kit	113
9.2.2 Vertiv™ Liebert® IntelliSlot™ IS-Relay Card	117
9.2.3 Vertiv™ Liebert® IntelliSlot™ RDU120 Card	118
9.2.4 Parallel Cable	119
9.2.5 Load Bus Synchronization Cable	119
9.2.6 Single Input Busbar Kit	119
9.2.7 Bypass Backfeed Protection Component (Optional)	119
10 Communication	121
10.1 SNMP Protocol Communication	121
10.2 Modbus Protocol Communication	121
10.3 Dry Contact Communication	122
10.3.1 Communication through Vertiv™ Liebert® IntelliSlot™ IS-Relay Card	122
10.3.2 Communication through Dry Contact Port of Central Control Module	122
11 Service and Maintenance	123
11.1 Safety for Service and Maintenance	123
11.2 Service Procedures of Power Module and Bypass Power Module	124
11.3 Key Components and Service Life of UPS	124
11.3.1 Life Parameters and the Proposed Replacement Time of Key Components	124
11.3.2 Replacement of Air Filter	125
11.4 Maintenance of UPS and Options	126

12 Specifications	127
12.1 Conformance and Standards	127
12.2 Environmental Characteristics	127
12.3 Mechanical Characteristics	128
12.4 Electrical Characteristics (Input Rectifier)	128
12.5 Electrical Characteristics (Battery Bus)	129
12.6 Electrical Characteristics (Inverter Output)	130
12.7 Electrical Characteristics (Bypass Input)	131
12.8 Efficiency and Loss	131
Appendices	133
Appendix A: Technical Support and Contacts	133
Appendix B: Glossary	134
Appendix C: Hazardous Substances and Content	136

This page intentionally left blank

1 Important Safety Instructions

Save These Instructions

This manual contains important instructions that should be followed during installation and maintenance of the uninterruptible power supply (UPS) and batteries of the Vertiv™ PowerUPS 9000 1250 kVA 415 V Modular UPS.

Read this manual thoroughly, paying special attention to the sections that apply to your installation, before working with the Vertiv PowerUPS 9000 1250 kVA 415 V Modular UPS. Retain this manual for use by installing personnel.

A properly trained and qualified electrical contractor should install the UPS.

The Vertiv PowerUPS 9000 1250 kVA 415 V Modular UPS cannot be put into operation until it is commissioned by the Vertiv authorized engineer. Otherwise, human safety may be endangered and damage to the UPS will not be covered by the warranty.

The Vertiv PowerUPS 9000 1250 kVA 415 V Modular UPS is designed for commercial and industrial uses and cannot be used as life support equipment.



WARNING! Risk of moving heavy equipment and electric shock. Can cause equipment damage, injury and death. Exercise extreme care when handling UPS cabinets to avoid equipment damage or injury to personnel. The weight range of Vertiv PowerUPS 9000 1250 kVA 415 V Modular UPS from 3847 to 4564 lb (1745 to 2070 kg). Determine unit weight and locate center of gravity symbols before handling the UPS. Test lift and balance the cabinet before transporting it. Never tilt equipment more than 15 degrees from vertical. In case of fire involving electrical equipment, use only carbon dioxide fire extinguishers or those approved for use in fighting electrical fires. Extreme caution is required when performing maintenance. Be constantly aware that the UPS system contains high DC as well as AC voltages. Check for voltage with both AC and DC voltmeters prior to making contact.



AVERTISSEMENT! Risque lors du déplacement de l'équipement lourd et de décharge électrique pouvant entraîner des dommages matériels, des blessures et même la mort. Faites preuve d'une extrême prudence lors de la manutention des armoires ASC afin d'éviter de les endommager ou de blesser le personnel. La plage de poids de l'onduleur modulaire Vertiv PowerUPS 9000 1250 kVA 415 V Modular UPS varie de 3847 à 4564 lb (1745 à 2070 kg). Repérez les symboles de centre de gravité avant de déplacer l'armoire ASC. Faites des essais de levage et d'équilibre avant de transporter l'armoire. N'inclinez jamais l'équipement à plus de 15 degrés à la verticale. En cas d'incendie associé à du matériel électrique, n'utilisez que des extincteurs à dioxyde de carbone ou homologués pour la lutte contre les incendies d'origine électrique. Les opérations d'entretien requièrent une extrême prudence. Soyez toujours conscient du fait que le système ASC contient des tensions c.c. et c.a. élevées. Vérifiez les tensions avec des voltmètres c.a. et c.c. avant d'établir tout contact.



WARNING! Risk of electric shock. Can cause equipment damage, injury, and death.

As with other types of high-power equipment, dangerous voltages are present within the UPS and battery enclosure even after input power has been disconnected. The risk of contact with these voltages is minimized as the live component parts are housed behind a metal panel. Further internal safety screens make the equipment protected to IP20 standards. Never remove panels or covers or open doors that will expose internal components to contact. Read and follow all warnings, cautions and safety and operating instructions to avoid serious injury or death from electric shock. No risk exists to any personnel when operating the equipment in the normal manner, following the recommended operating procedures. All equipment maintenance and servicing procedures involve internal access and should be carried out only by trained personnel.



AVERTISSEMENT! Risque de décharge électrique pouvant entraîner des dommages matériels, des blessures et même la mort. À l'instar des autres types d'équipement haute puissance, des tensions dangereuses sont présentes à l'intérieur de l'armoire ASC et du châssis de batteries même après le débranchement de l'alimentation d'entrée. Le risque de contact avec ces tensions est diminué, car les parties de composants sous tension sont abritées derrière un panneau métallique. D'autres écrans de sécurité internes protègent l'équipement en conformité avec les normes IP20. Ne retirez jamais les panneaux ou les couvercles et n'ouvrez pas les portes donnant accès aux composants internes avec lesquels vous pouvez entrer en contact. Veuillez lire et suivre l'ensemble des avertissements, des mises en garde et des instructions de sécurité et de fonctionnement afin d'éviter des blessures graves, voire la mort, pouvant être causées par une décharge électrique. Il n'y a aucun risque pour le personnel lorsque l'équipement est utilisé normalement, en suivant les procédures de fonctionnement recommandées.

Ground Leakage Current



WARNING! Risk of electric shock from high leakage current. Can cause injury, property damage and death. Earth connection is essential before connecting the input supply. Earth leakage current exceeds 3.5 mA and is less than 3000 mA. Transient and steady state earth leakage currents, which may occur when starting the equipment, should be considered when selecting instantaneous residual current circuit breakers (RCCB) or residual current device (RCD). RCCBs must be selected sensitive to DC unidirectional pulses (Class A) and insensitive to transient current pulses. Note that the earth leakage currents of the load will be carried by this RCCB or RCD. This equipment must be earthed in accordance with the local electrical code of practice.



AVERTISSEMENT! Risque de choc électrique dû à un courant de fuite élevé. Peut causer des blessures, des dommages matériels et la mort. La connexion à la terre est essentielle avant de connecter l'alimentation d'entrée. Le courant de fuite à la terre dépasse 3.5 mA et est inférieur à 3000 mA. Les courants de fuite à la terre transitoires et stationnaires, qui peuvent se produire lors du démarrage de l'équipement, doivent être pris en compte lors de la sélection des disjoncteurs à courant résiduel instantané (RCCB) ou des dispositifs dispositif à courant résiduel (RCD). Les disjoncteurs différentiels doivent être sélectionnés sensibles aux impulsions unidirectionnelles CC (classe A) et insensibles aux impulsions de courant transitoire. Notez également que les courants de fuite à la terre de la charge seront transportés par ce disjoncteur différentiel ou disjoncteur différentiel. Cet équipement doit être mis à la terre conformément au code de pratique électrique local.



WARNING! Risk of electric shock. Can cause injury, property damage and death. Under typical operation and with all UPS doors closed, only normal safety precautions are necessary. The area around the UPS system should be kept free of puddles of water, excess moisture, and debris. Special safety precautions are required for procedures involving handling, installation, and maintenance of the UPS system. Observe all safety precautions in this manual before handling or installing the UPS system as well as during all maintenance procedures. This equipment contains several circuits that are energized with high voltage. Only test equipment designed for troubleshooting should be used. This is particularly true for oscilloscopes. Always check with AC and DC voltmeters to ensure safety before making contact or using tools. Even when the power is turned Off, dangerously high electric charges may exist within the UPS. All power and control wiring should be installed by a qualified electrician. All power and control wiring must comply with the NEC and applicable local codes. ONLY qualified service personnel should perform maintenance on the UPS system. When performing maintenance with any part of the equipment under power, service personnel and test equipment should be standing on rubber mats. The service personnel should wear insulating shoes for isolation from direct contact with the floor (earth ground). Never work alone, even if all power is disconnected from the equipment. A second person should be standing by to assist and summon help in case an accident should occur.



AVERTISSEMENT! Risque de décharge électrique pouvant causer des blessures, des dommages matériels et même la mort. Les précautions de sécurité habituelles suffisent lorsque le système ASC est en mode de fonctionnement normal et que toutes les portes sont fermées. La zone entourant le système ASC doit être exempte de flaques d'eau, d'humidité excessive et de débris. Des précautions de sécurité spéciales sont requises pour les procédures associées à la manutention, à l'installation et à l'entretien du système ASC. Observez toutes les précautions de sécurité décrites dans le présent manuel avant de manipuler ou d'installer le système ASC, ainsi que pendant toutes les procédures d'entretien. Cet équipement comporte plusieurs circuits à haute tension. Seuls des équipements d'essai conçus pour le dépannage doivent être utilisés. Cette mise en garde couvre notamment les oscilloscopes. Utilisez toujours des voltmètres c.a. et c.c. pour vérifier les tensions avant d'établir un contact ou d'utiliser des outils. Des tensions dangereusement élevées peuvent demeurer dans le système ASC même une fois l'alimentation coupée. Tous les câbles d'alimentation et de contrôle doivent être installés par un électricien qualifié. Tous les câbles d'alimentation et de contrôle doivent être conformes au Code national de l'électricité des États Unis (NEC) et celui du Canada, ainsi qu'aux codes locaux en vigueur. L'entretien du système ASC ne doit être confié qu'à des professionnels qualifiés. Les responsables de l'entretien et l'équipement d'essai doivent reposer sur des tapis de caoutchouc lors de toute intervention sur une pièce d'équipement sous tension. Les responsables de l'entretien doivent porter des chaussures isolantes pour prévenir tout contact direct avec le plancher. Ne travaillez jamais seul, même si toute l'alimentation d'entrée est coupée de l'équipement. Une seconde personne devrait toujours être présente pour porter assistance ou chercher de l'aide en cas d'accident.

NOTICE

Risk of improper ground connection. Can cause equipment damage. Ground connection is essential before connecting the input supply. This equipment must be grounded in accordance with local electrical codes. Maximum load must not exceed that shown on the UPS rating label. Risk of improper electromagnetic shielding. Can cause radio communication interference. This unit complies with the limits for a Class A digital device, pursuant to part 15 subpart J of the FCC rules. These limits provide reasonable protection against harmful interference in a commercial environment. This unit generates, uses, and radiates radio frequency energy and, if not installed and used in accordance with this instruction manual, may cause harmful interference to radio communications. This unit is not designed for use in a residential area. Operation of this unit in a residential area may cause harmful interference that the user is solely responsible for correcting.



WARNING! Failure to follow adequate grounding procedures can result in electric shock hazard to personnel, or the risk of fire, should a ground fault occur. All operations described in this section must be performed by properly trained and qualified electricians or technical personnel. If any difficulties are encountered, contact Vertiv. See the back page of this manual for contact information. This device complies with part 15 of the FCC Rules. Operation is subject to the following two conditions: (1) This device may not cause harmful interference, and (2) this device must accept any interference received, including interference that may cause undesired operation.









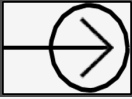
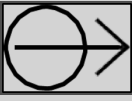

AVERTISSEMENT! Le non respect des procédures de mise à la terre peut entraîner des risques d'électrocution du personnel, ou des risques d'incendie en cas de défectuosité de la mise à la terre. Toutes les opérations décrites dans cette section ne doivent être effectuées que par des électriciens ou des techniciens professionnels dûment formés et qualifiés . En cas de difficultés, communiquez avec Vertiv. Pour obtenir les renseignements de contact, consultez la dernière page de ce manuel.

NOTICE

This equipment has been tested and found to comply with the limits for a Class A digital device, pursuant to part 15 of the FCC Rules. These limits are designed to provide reasonable protection against harmful interference when the equipment is operated in a commercial environment. This equipment generates, uses, and can radiate radio frequency energy and, if not installed and used in accordance with the instruction manual, may cause harmful interference to radio communications. Operation of this equipment in a residential area is likely to cause harmful interference in which case the user will be required to correct the interference at his own expense.

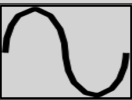
1.1 Glossary of Symbols

	<p>Risk of electrical shock</p>
	<p>Indicates caution followed by important instructions</p>
	<p>AC Input</p>
	<p>AC Output</p>
	<p>Requests the user to read the manual</p>
	<p>Recycle</p>
	<p>DC Voltage</p>
	<p>AC Voltage</p>
	<p>Equipment grounding conductor</p>
	<p>Bonded to ground</p>

This page intentionally left blank

2 Overview

This chapter describes the features, design concept, parallel system, operation mode, battery management, and battery protection of the Vertiv™ PowerUPS 9000 1250 kVA 415 V Modular UPS.

2.1 Introduction

The Vertiv PowerUPS 9000 1250 kVA 415 V Modular UPS can be configured as either a fixed-capacity or scalable, transformer-free, online power system with 415 VAC output. The system supports operation at both 50 Hz and 60 Hz frequencies.

When configured for scalability, the capacity of UPS can be set according to **Table 2.1** below.

The Vertiv PowerUPS 9000 1250 kVA 415 V Modular UPS provides continuous, high quality AC power to business-critical equipment, such as telecommunications and data processing equipment. The Vertiv PowerUPS 9000 1250 kVA 415 V Modular UPS supplies power free of the disturbances and variations in voltage and frequency common to utility power, which is subject to brownouts, blackouts, surges, and sags.

The Vertiv PowerUPS 9000 1250 kVA 415 V Modular UPS utilizes the latest high frequency, double conversion pulse width modulation (PWM) technology and fully digital controls to enhance its reliability and increase the ease of use.

The Vertiv PowerUPS 9000 1250 kVA 415 V Modular UPS requires external batteries to support the load when utility power is not present.

Table 2.1 The Vertiv PowerUPS 9000 1250 kVA 415 V Modular UPS Model and Power Scale

Product	Power Scalability	Remark
The Vertiv PowerUPS 9000 1250 kVA 415 V Modular UPS 4-wire 50/60 Hz	250, 375, 500, 625, 750, 875, 1000, 1100, 1125, 1200, 1250	The external battery must be configured by authorized Vertiv service personnel.

2.2 Features

The UPS is connected between a critical load, such as a computer, and mains power to provide high quality power for the loads.

The UPS has the following advantages:

- Improves the input power quality.
- The UPS protects its output against the input power change through the intelligent controller.
- Provides protection for mains failures in the event of a mains direct power source failure.
- If the input power fails, the UPS switches to battery mode and the power supply to the loads will not be interrupted.

2.3 Control and Display Panel

Information about using the UPS control panel is detailed in **Vertiv™ Liebert® Touchscreen Control Panel User Manual SL-26200**, available at Vertiv's web site <https://www.vertiv.com>.

2.4 Operation Modes

The Vertiv™ PowerUPS 9000 1250 kVA 415 V Modular UPS has the following operation modes:

- Normal mode
- Battery mode
- Automatic restart mode
- Bypass mode
- ECO mode
- Frequency converter mode
- Dynamic online mode
- Load bus synchronization (LBS) mode
- Parallel mode

2.4.1 Normal Mode

As shown in **Figure 2.1** below, the main input AC voltage is converted to DC voltage by the UPS rectifier and converted to conditioned AC voltage by the inverter to supply uninterrupted AC power to the loads. At the same time, the charger uses the DC voltage from the rectifier to charge the battery.

Figure 2.1 Schematic Diagram of Normal Mode

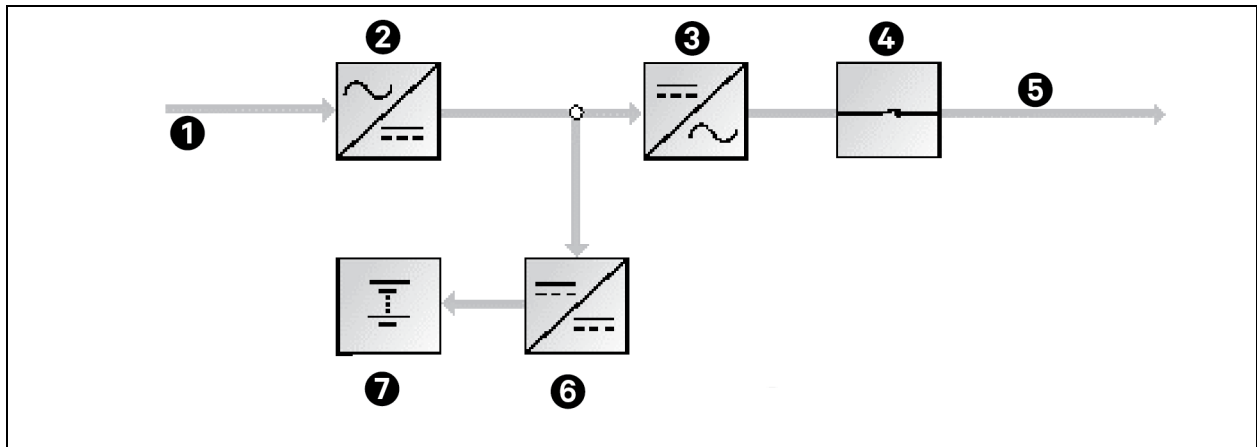

Item	Description	Item	Description
1	Main input	5	UPS output
2	Rectifier	6	Battery charger/discharger
3	Inverter	7	Battery
4	Automatic inverter switch		

2.4.2 Battery Mode

As shown in **Figure 2.2** below, the operation mode in which the battery provides backup DC power supply to inverter to provide backup power to the load. When the load rate exceeds the limit, the auxiliary discharger starts, and the battery provides backup power to the load through the rectifier, auxiliary discharger and inverter. Upon mains failure, the system automatically transfers to the battery mode with no load power interruption. When the mains is recovered, the system automatically transfers back to the normal mode without any manual intervention, and the power to the load will not be interrupted.

Figure 2.2 Schematic Diagram of Battery Mode

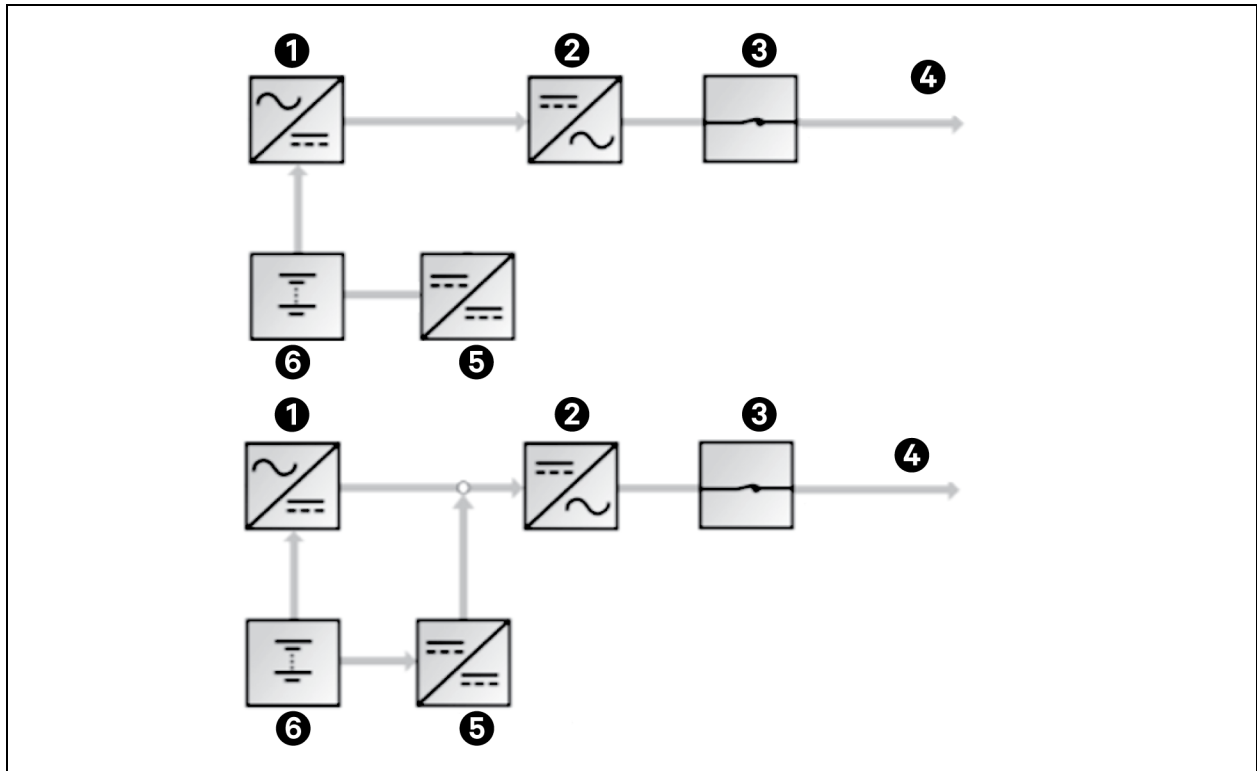

Item	Description	Item	Description
1	Rectifier	4	Output switch
2	Inverter	5	Battery charger/discharger
3	Automatic inverter switch	6	Battery

NOTE: Battery cold start function is available for switching the UPS ON from the battery (charged) mode directly during a mains failure. The battery power supply is used independently to improve the availability of the UPS.

2.4.3 Automatic Restart Mode

The battery may become exhausted following an extended AC utility failure. The inverter shuts down when the battery reaches the end of discharge (EOD) voltage. The UPS may be programmed to auto recover after EOD after a delay time if the AC utility recovers. This mode and any delay time may be programmed by the commissioning engineer.

NOTE: EOD without battery circuit breaker (BCB) trip functions must be set by a Vertiv authorized service engineer.

Automatic restart helps to delay the shutdown process and the UPS will charge the battery to protect against the power OFF risk of the load device caused by mains power failure.

NOTE: The user can manually start the UPS through RESET FAULT function. If the automatic restart function has not set.

2.4.4 Bypass Mode

When the UPS is in bypass mode and the inverter fails or the inverter gets overloaded or the inverter is shutdown manually, the static switch will transfer the load from the inverter to bypass without interrupting the power to the load. See **Figure 2.3** below for more details.

NOTE: While transferring the load from the inverter to the bypass, if both are not synchronized, the power supply to the power load has transitory interruptions with a time of less than 20 milliseconds.

Figure 2.3 Schematic Diagram of Bypass Mode

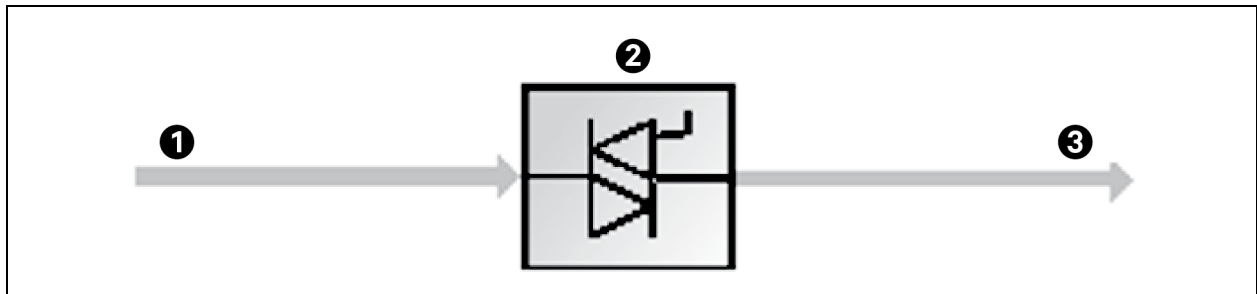

Item	Description
1	Bypass input
2	Static switch
3	UPS output

2.4.5 ECO Mode

As shown in **Figure 2.4** below, if ECO mode is selected, all power breakers and the battery breakers are closed, and the system puts the load on the bypass mode, for energy saving. When the bypass supply is within the range of normal frequency and normal voltage (adjustable), the load is powered by the bypass, with the inverter on standby; when the voltage and/or frequency of the bypass supply are beyond the pre-defined and adjustable limits, the system will transfer to the inverter output and the transfer time for switching from bypass to inverter is less than 2 milliseconds (uninterrupted) and less than 5 milliseconds (interrupted). In this mode, the system can normally charge the battery.

Figure 2.4 Schematic Diagram of ECO Mode

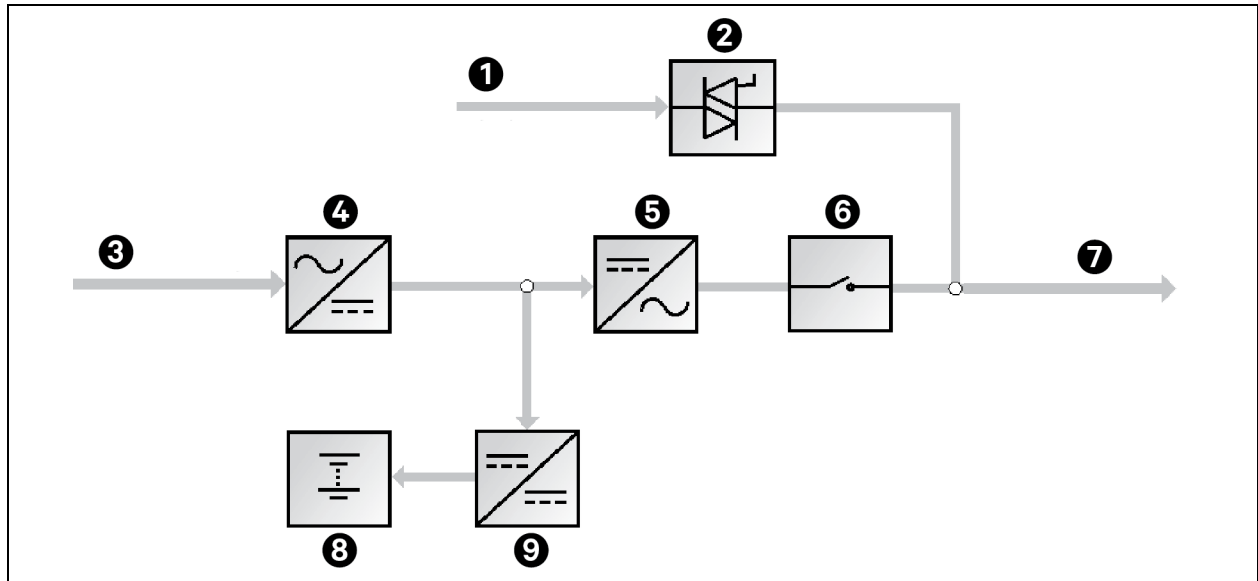

Item	Description	Item	Description
1	Bypass input	6	Automatic inverter switch
2	Static switch	7	UPS output
3	Mains input	8	Battery
4	Rectifier	9	Battery charger/discharger
5	Inverter		

NOTE: If ECO mode is required, adjust the parameters through the touch screen.

The operation method of ECO mode is the same as the description in [Single UPS Operation](#) on page 75. In normal mode, the load is powered by the bypass, the touchscreen displays Bypass mode.

NOTE: In ECO mode, the UPS operates in voltage and frequency dependent (VFD) mode. The load is not protected against input voltage harmonic distortion (UTHD) or minor frequency variations.

2.4.6 Frequency Converter Mode

The UPS can be programmed into frequency converter mode for either 50 Hz or 60 Hz stable output frequency. The input frequency may vary from 40 to 70 Hz. In this mode, open the maintenance bypass breaker (MBB) and disable the static bypass operation, and the battery becomes optional depending on any requirement to operate in battery mode. The frequency converter mode is set by the service engineer through the setting software.

2.4.7 Dynamic Online Mode

As shown in **Figure 2.5** below, when the UPS is in dynamic online mode, all power breakers and battery breakers are turned ON. The load power is preferentially supplied by bypass to save energy. When the load power supply is provided by bypass, the inverter is in the mode of quality compensation for the bypass voltage. When the bypass voltage exceeds the normal range, the system will switch to the inverter output. In this mode, the battery can still be charged through the charger normally.

Figure 2.5 Dynamic Online Mode

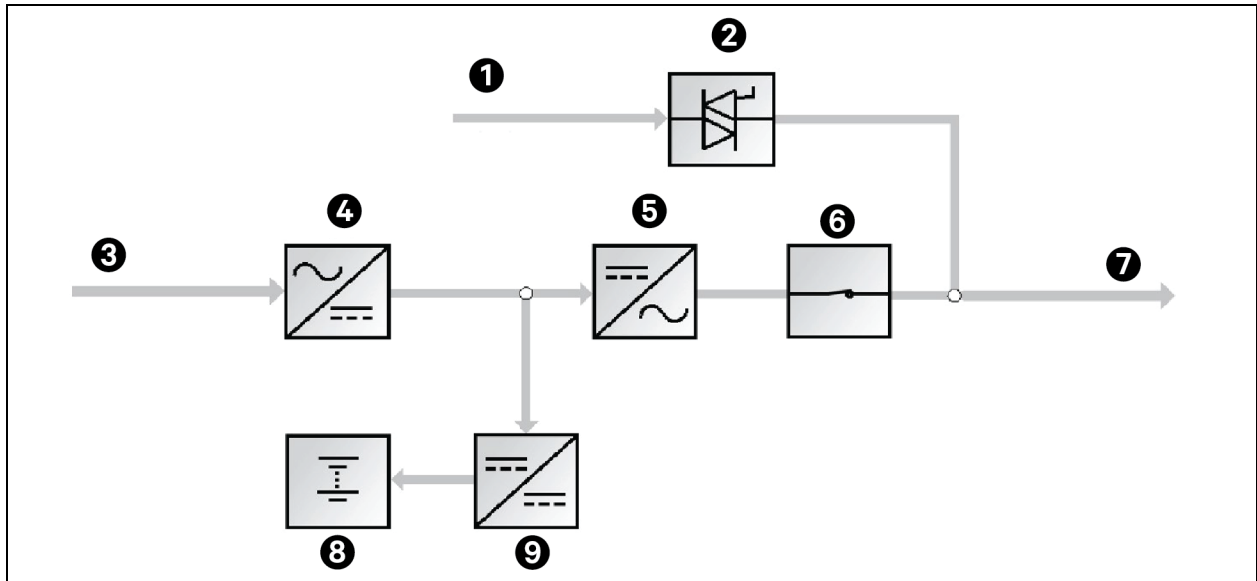

Item	Description	Item	Description
1	Bypass input	6	Automatic inverter switch
2	Static switch	7	UPS output
3	Mains input	8	Battery
4	Rectifier	9	Battery charger/discharger
5	Inverter		

2.4.8 Parallel Mode (System Expansion)

For higher capacity or higher reliability, the outputs of multiple UPS units can be programmed for directly paralleling while a built-in parallel controller in each UPS unit ensures automatic load sharing. The parallel system can be composed of up to four UPS units. For the principle operation diagram of the parallel mode, see **Figure 8.2** on page 104.

2.4.9 Load Bus Synchronization Mode

A dual bus system consists of two independent UPS systems, each containing one or more parallel UPS units. The dual bus system has high reliability and is applicable to the load with multiple inputs. For single-input load, a static transfer switch (STS) can be installed to power the load. For the principle operation diagram of the LBS mode, see **Figure 8.5** on page 108 and **Figure 8.6** on page 109.

2.5 Battery Management System

Battery management system (BMS) functions are set by the Vertiv service engineer through the setting software.

2.5.1 Normal Function

- **Constant current boost charge:** Adopt the constant current (within battery charging limit) to charge the battery. The function is for fast recovery of battery capacity. The charge current can be set.
- **Constant voltage boost charge:** Adopt the constant voltage to charge battery. The function is for fast recovery of battery capacity.
- **Float charge:** The charging method is for keeping battery in full capacity. The function can balance the capacity loss due to battery self-discharge and is used for battery capacity recovery.
- **Automatic transfer to float charge:** When the charge current is less than threshold of equalize charge to Float Charge or 0.5 A, the charger will automatically transfer from boost charge to float charge. When boost charge time exceeds the equalize charge protect time limit, the charger will transfer to float charge to protect the battery.
- **Float charge temperature compensation (optional):** This function must be used with the battery temperature detection device. The Vertiv battery temperature sensor is a standard option for the selection.
- **EOD protection:** When the battery voltage drops to the EOD voltage, the battery converter shuts down automatically and the battery is inhibited to avoid further battery discharge.
- **Battery low pre-warning time:** The battery low pre-warning time is adjustable between 2 minutes and 60 minutes. The default setting is 5 minutes.
- **Maximum battery discharge time:** When the battery has a small current discharge over a long time, the battery is over discharged and has unrecoverable damage. Setting a battery discharge time to protect the battery is essential. The time limit setting must be configured by service engineer through the Vertiv setting software.
- **Maximum boost charge protection time:** To protect against the battery overcharge damage caused by long time boost charge, a protect time setting is essential. The limit of time setting shall be configured by service engineer through the Vertiv setting software.

NOTE: For detailed battery parameters, see **Table 12.4** on page 129.

2.5.2 Advanced Functions

Table 2.2 Battery Test Function Requirements and Operating Conditions

Parameter	Manual Battery Test	Automatic Battery Test	Remote Battery Test	Calibrated Battery Test
Load	0% <Load <100%	20% <Load <100%	20% <Load <100%	20% <Load <100%
Required Battery Voltage	≥97% of float charge voltage	≥97% of float charge voltage	≥97% of float charge voltage	≥97% of float charge voltage
Charger Status	Float charge*	Float charge*	Float charge*	Float charge*
Setting	N/A	Automatic battery test must be enabled and scheduled	N/A	N/A
Trigger	From global human machine interface (GHMI)	Automatic	Through the input dry contractor	From GHMI
Action	Discharging until battery capacity is 80%	Discharging until battery capacity is 80%	Discharging until battery capacity is 80%	Discharging until battery is close to EOD state
Info	N/A	N/A	Only required when the utility power is present and there are no active alarm conditions.	N/A

*Float charge status required for at least 5 hours with VRLA, high discharge VRLA, wet, Ni-Cd batteries.

NOTE: The battery continuously discharges to the battery under voltage shutdown threshold. The battery then transfers to the charging state. When the capacity self-test is finished, the system updates the battery curve table.

NOTE: The capacity self-test can be stopped using the touchscreen.

2.5.3 Battery Temperature Compensation

The UPS system has battery charge temperature compensation function. When the ambient temperature is increased, the DC bus voltage (which charges the battery) is reduced correspondingly to provide optimal charging voltage for the battery, prolonging the battery service lifetime.

NOTE: This is applicable to battery types that can accept battery temperature compensation.

2.6 Battery Protection



WARNING! The user must select an appropriate molded case circuit breaker (MCCB) to protect against short circuit and overload for the battery. It is recommended to use the Vertiv battery to provide a better solution.



AVERTISSEMENT! L'utilisateur doit sélectionner un disjoncteur moulé approprié (MCCB) pour protéger contre les courts-circuits et les surcharges de la batterie. Il est recommandé d'utiliser la batterie Vertiv pour fournir une meilleure solution.

The following battery protection functions are set by the service engineer through the Vertiv setting software.

2.6.1 Battery Low Pre-warning

The battery low pre-warning occurs before the EOD. After this pre-warning, the battery should have the capacity of 3 minutes discharging with full load. The time can be configured from 2 minutes to 60 minutes.

2.6.2 EOD Protection

When the battery voltage drops to the EOD voltage, the battery shut down automatically. See **Table 12.4** on page 129 for battery EOD voltage parameters of various batteries.

2.6.3 Battery Circuit Breaker Alarm

The external battery connects to the UPS through the BCB. The BCB is manually closed and tripped by the UPS control circuit.

2.7 Parallel System and Load Bus Synchronization System

2.7.1 Parallel System

For higher capacity or higher reliability, the outputs of multiple UPS units can be programmed to parallel directly. The built in parallel controller in each UPS module ensures automatic load sharing. A parallel system can include up to four UPS units. For the principle operation diagram of the parallel redundancy mode, see **Figure 8.1** on page 102.

The parallel system has the following characteristics:

1. The hardware and software of parallel system are completely the same as those of the single module. The parallel system configuration is achieved through settings in configuration software.
2. Parallel cables are connected in a ring, providing both system reliability and redundancy.
3. The total load of the parallel system is identified from the touchscreen of each UPS module.

2.7.2 Parallel System Requirements

A group of UPS units operating in parallel functions as a single high-capacity UPS to provide increased reliability.

To ensure balanced load sharing and compliance with applicable wiring requirements, the following conditions must be met:

- All UPS units shall be of the same model and connected to a common bypass power source.

2.7.3 Load Bus Synchronization System

A dual bus system consists of two independent UPS systems, each containing one or more parallel UPS units. Unlike parallel operation, the LBS facilitates a seamless transfer of loads between different UPS systems by ensuring the synchronization of the UPS systems. The dual bus system has high reliability and is applicable to the load with multiple inputs. For a single input load, a STS can be installed to power the load. For the principle operation diagram of the LBS mode, see **Figure 8.5** on page 108 and **Figure 8.6** on page 109.

This page intentionally left blank

3 Mechanical Installation

This chapter provides brief instructions for mechanical installation of the Vertiv™ PowerUPS 9000 1250 kVA 415 V Modular UPS, including environmental requirements, mechanical requirements, and mechanical considerations necessary when planning the positioning and the cabling of the UPS equipment.

3.1 Precautions

This section is a guide to general procedures and practices that are to be observed by the installation engineer, so that they can troubleshoot the specific situation of the site. The detailed installation steps are not provided in this section due to unique characteristic of each installation site.

NOTE: Professional installation required. Do not disassemble the package without permission of authorized service engineer. The UPS should be installed by authorized personnel in accordance with the information provided in this chapter.

NOTE: The UPS can be connected to IT, TN, and TT AC distribution systems, and must be a 4-wire (A, B, C, N, PE) (only for 415 V) system.



WARNING! Risk of electric shock. It can cause damage to the property, serious injury, or death. When connecting batteries, the battery terminal voltage will reach 400 VDC and more. Take special care when installing batteries.



AVERTISSEMENT! Risque de choc électrique. Cela peut provoquer des dommages matériels, des blessures graves ou la mort. Lors de la connexion des batteries, la tension des bornes de la batterie atteindra 400 VCC et plus. Faites particulièrement attention lors de l'installation des batteries.

The following safety precautions must be followed while working on the batteries:

- Always wear protective equipment including eye wear and rubber gloves.
- Remove all the metal tools and jewelry, including finger rings, and wristwatch.
- Use tools with an insulated handle.
- If the battery has electrolyte leakage or the battery is damaged, it must be replaced. Place the battery into a container that can withstand sulfuric acid and dispose of it according to local regulations.
- If you meet the battery's electrolyte, wash and flush the area with water immediately. If it meets your eyes, flush them with water and get medical aid immediately.

3.2 Transportation



WARNING! Risk of moving heavy unit and tipping over while moving. Can cause equipment damage, personnel injury, or death. The UPS cabinet is heavy. See **Table 12.2** on page 128 weight of the cabinet. Make sure that any equipment that will be used to move the UPS cabinet has sufficient lifting capacity. The UPS cabinet presents a tipping hazard. Do not tilt the cabinet more than 15 degrees from vertical while transportation.



AVERTISSEMENT! Risque de déplacer une unité lourde et de basculer pendant le déplacement. Peut causer des dommages à l'équipement, des blessures au personnel ou la mort. L'armoire UPS est lourde. Voir le **Table 12.2** on page 128 pour le poids de l'armoire. Assurez-vous que tout équipement utilisé pour déplacer l'armoire UPS dispose d'une capacité de levage suffisante. L'armoire UPS présente un risque de basculement. Ne pas incliner l'armoire de plus de 15 degrés par rapport à la verticale pendant le transport.

It is recommended to use mechanical equipment like an electric forklift to unload and transport the cabinet to the installation site. If an electric forklift is used, insert the tines of the forklift below the bottom pallet to prevent the cabinet from falling over and maintain the same direction of force application for unloading the cabinet from the pallet. See **Figure 3.1** below, **Figure 3.2** on the facing page, and **Table 3.1** on the facing page.

Figure 3.1 Moving the Cabinet (Cabinet Front)

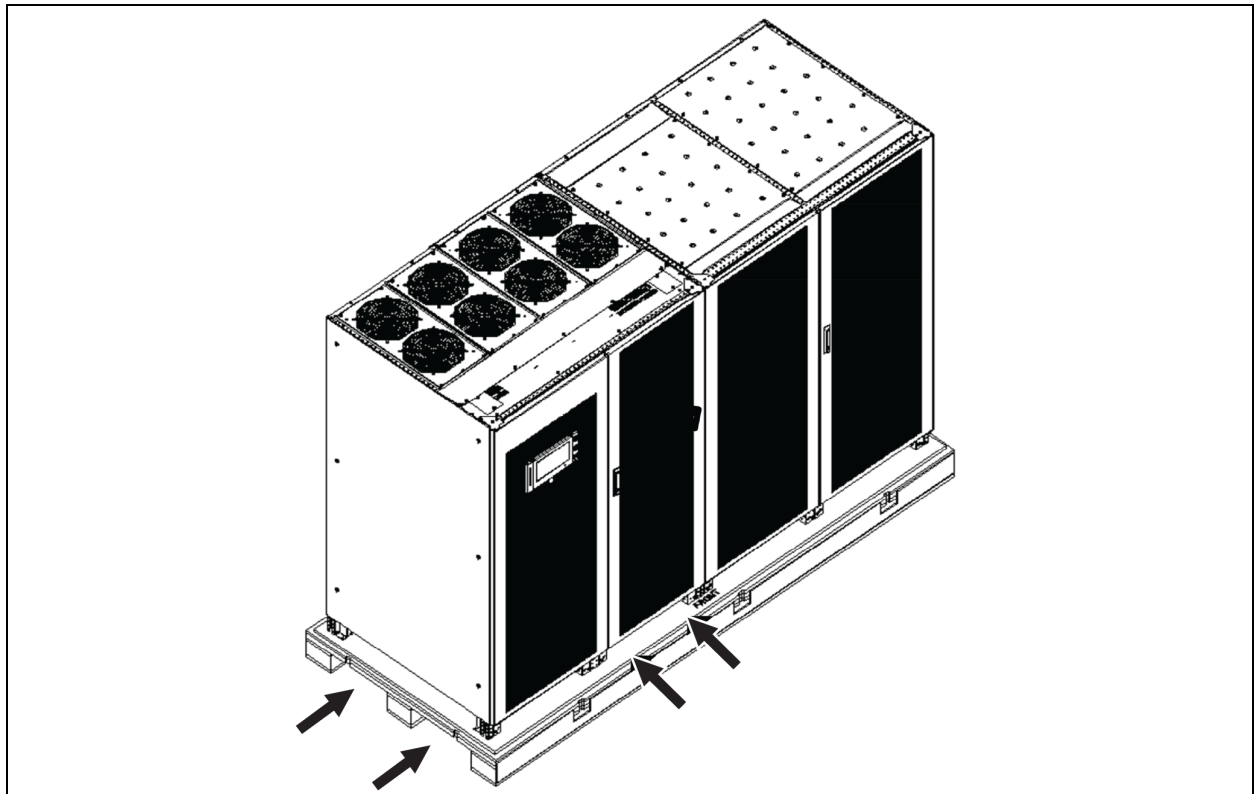

NOTE: Side insertion or front insertion is available. Enter from the side under the pallet and from the front between the cabinet and the pallet.

Figure 3.2 Center of Gravity Drawing

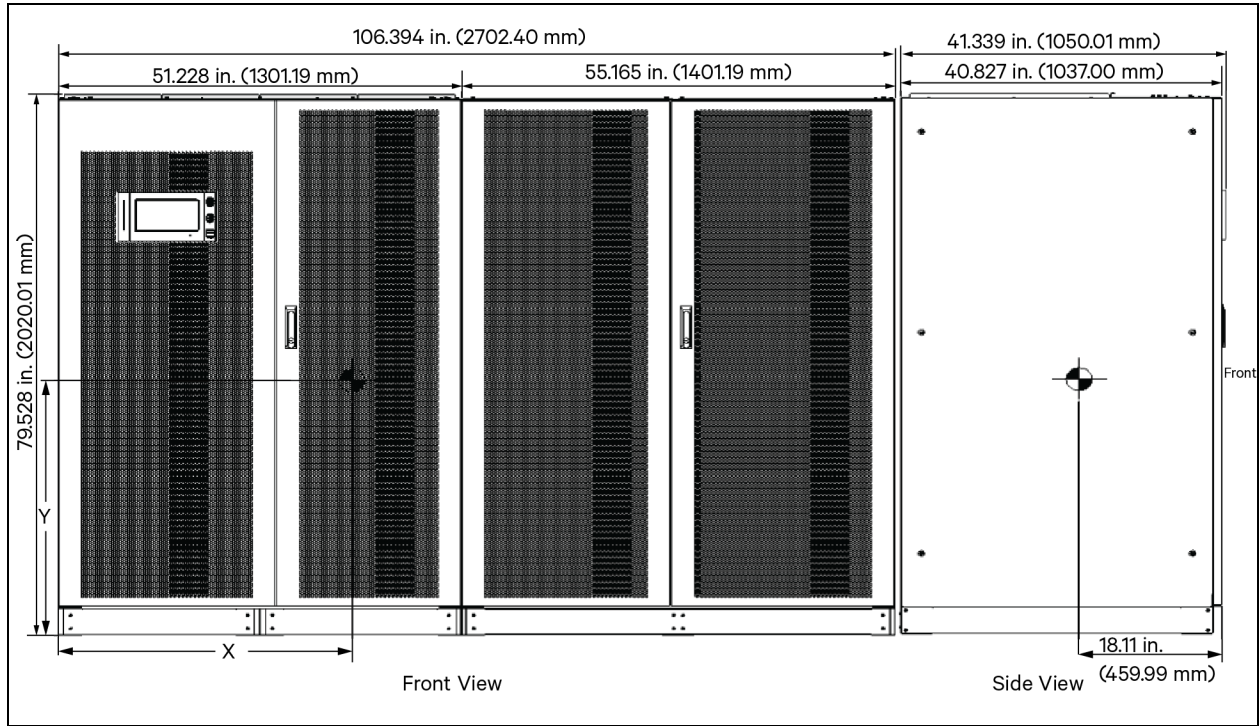













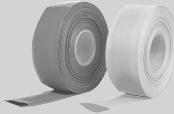







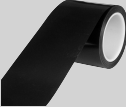

Table 3.1 Center of Gravity Dimensions

Ratings	X In. (mm)	Y In. (mm)
1250K	37.402 (950.011)	37.402 (950.011)
1125K	37.598 (954.989)	37.205 (945.007)
1000K	37.402 (950.011)	37.008 (940.003)
875K	37.992 (964.997)	36.811 (934.999)
750K	38.189 (970.001)	36.614 (929.996)
625K	38.389 (975.081)	36.417 (924.992)

3.3 Tools

The tools listed in the **Table 3.2** below are required for installation and connection. The list below is provided for reference only.

Table 3.2 Tools

Name	Drawing	Name	Drawing	Name	Drawing
Electric hand drill		Adjustable wrench		Crimping plier	
Slotted screwdriver		Cross head screwdriver		Insulated torque wrench	
Stepladder		Forklift		Multimeter	
Drill		Wire cutting plier		Heat shrinkable tube	
Claw hammer		Diagonal cutting plier		Torque screwdriver	
Insulating shoes		Antistatic gloves		Clip-on ammeter	
Electrician knife		Cable tie			
Insulating tape		Insulating gloves			

3.4 Unpacking

Before unpacking the UPS and battery, inspect for any visual damage or signs of mishandling. Under the guidance of authorized service engineer.

Follow the below steps to unpack the UPS and battery packages:

1. Remove the packing belts and honeycomb boards as shown in **Figure 3.3** below.

Figure 3.3 Removing the Packing Belts and Honeycomb Boards

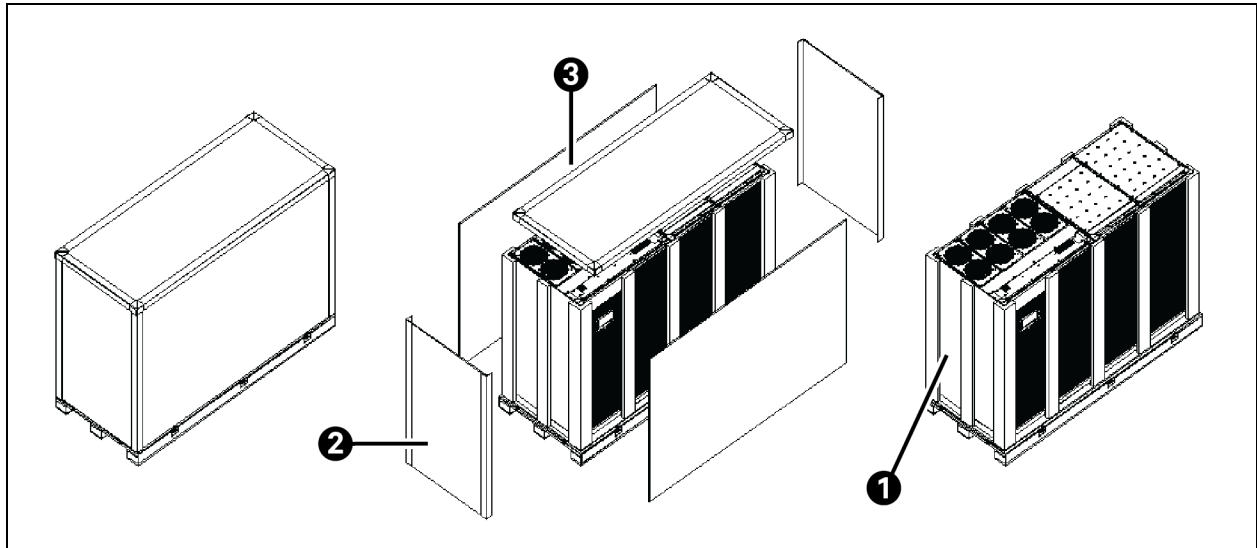

Item	Description
1	Honeycomb cardboard
2	Side pallet
3	Top cover

2. Remove the bottom fixing bolts shown in **Figure 3.4** below.

Figure 3.4 Removing Bottom Fixing Bolts

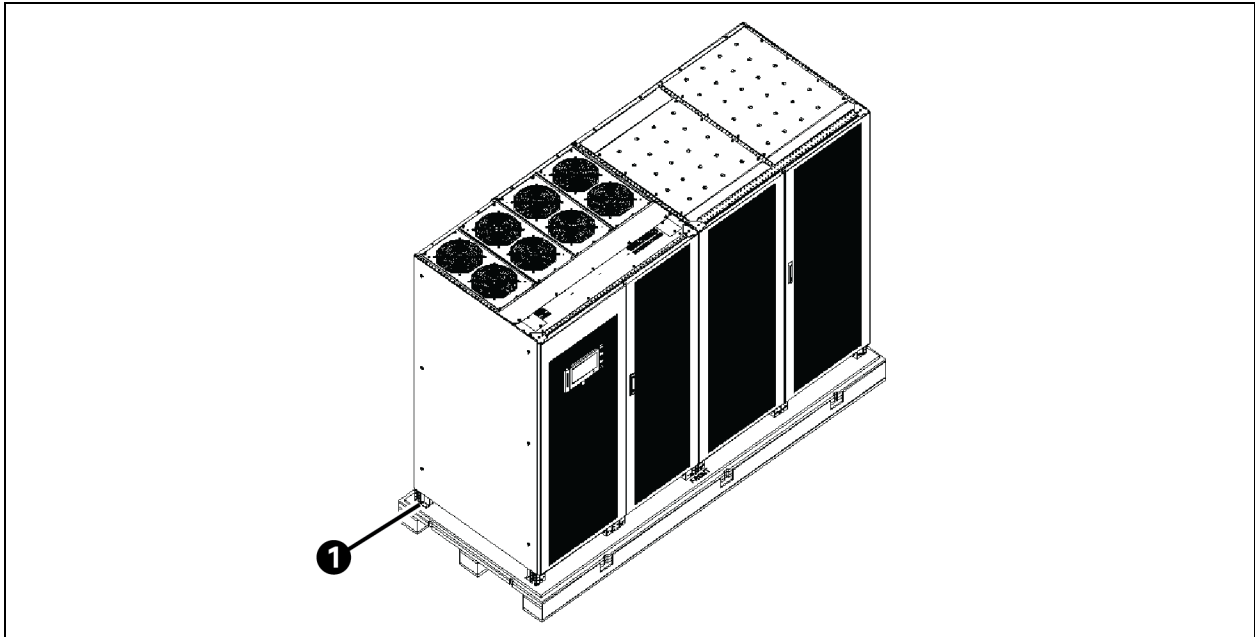

Item	Description
1	Fixing bolt

3. Move the cabinet to the installation location using the forklift. See [Transportation](#) on page 18 for more details. Secure cabinet to the ground as shown in **Figure 9.1** on page 114.
4. Make sure to install the kick plate, after the Vertiv™ PowerUPS 9000 1250 kVA 415 V Modular UPS is installed.

3.5 Pre-installation Inspection

Before installing the UPS, carry out the following inspections:

1. Ensure that the UPS equipment room’s environment complies with the environmental requirement specified in the [Environmental Characteristics](#) on page 127, especially the ambient temperature, ventilation conditions, and the dust situations.
2. Visually inspect the UPS and battery for any sign of transportation damage or mishandling. Do not attempt to install the system, if damage is apparent. Report it to the carrier or Vertiv representative immediately. Unpack the UPS and battery under the guidance of authorized service engineer.
3. Check the UPS label on the back of the door and confirm the contents match the UPS model, capacity and main parameters that were ordered.

3.6 Environmental Requirement

3.6.1 UPS Location Selection

Before installing the Vertiv™ PowerUPS 9000 1250 kVA 415 V Modular UPS, verify that the environment of the room where the UPS is to be installed complies with the environmental requirements as specified in relevant international standard and specifications and within operating ranges given in **Table 12.1** on page 127. Pay special attention to the ambient temperature and the air exchange system. Install the UPS in a cool, dry, clean air indoor environment with adequate ventilation and on concrete or other nonflammable, flat surfaces. The ambient environment should be free of conductive powder (such as, metallic powder, sulfide, sulfur dioxide, graphite, carbon fiber, conductive fiber) and acid mist or other conductive media (strongly ionized substances).

The Vertiv PowerUPS 9000 1250 kVA 415 V Modular UPS is cooled by internal fans. Cooling air enters the UPS through the ventilation grills at the front of the cabinet and is exhaust through the top fans. To permit proper air flow and prevent overheating, do not block, or cover the ventilation openings (ventilation grille) or blow air down onto the unit. The UPS requires at least 24 in. (610 mm) ventilation clearance at the top side of the unit to avoid blocking the UPS heat dissipation, thus reducing the UPS internal temperature, and improving the UPS life.

If necessary, install indoor extractor fans to aid cooling air flow to avoid increase in the room temperature.

NOTE: When installing UPS, use M12 expansion bolts to fix the base of the cabinet on the floor to prevent the cabinet from falling due to uneven ground.

NOTE: When the battery cabinet is installed near the UPS, the maximum allowable ambient temperature is dependent on the battery rather than the UPS.

NOTE: If the UPS is working in ECO mode, the power consumption will be less than that in Normal mode. Proper air conditioning system should be selected according to the normal operating mode.

3.6.2 Battery Location Selection

Some battery chemistries generate some hydrogen and oxygen at the end of a charge, so the fresh air volume of the battery installation environment must meet the EN50272-2001 requirements.

The battery can be installed inside a specialized battery cabinet that must be close to UPS. If the battery is placed on a raised floor, a bracket must be installed under the floor, just as for the UPS. If the battery adopts rack mounting or is mounted far from the UPS with other installation mode, the BCB must be installed near the battery and the cabling distance must be minimized.

3.6.3 Storage

If the UPS will not be installed immediately, it must be stored in the original packaging indoors in a clean, dry, and cool location protected from excessive humidity and heat sources. See **Table 12.1** on page 127 for more details. The battery needs to be stored in a dry and cool place with good ventilation. The most suitable storage temperature ranges are 68 °F (20 °C) to 77 °F (25 °C).



WARNING! During battery storage, periodically charge the battery according to the battery manufacturer instructions. Users can obtain battery storage information by consulting the battery manufacturer's data sheet.



AVERTISSEMENT! Pendant le stockage de la batterie, chargez périodiquement la batterie selon les instructions du fabricant de la batterie. Les utilisateurs peuvent obtenir des informations sur le stockage de la batterie en consultant la fiche technique du fabricant de la batterie.

3.7 Mechanical Requirement

3.7.1 Composition

For 1250 kVA 415 V UPS, the UPS with I/O cabinet is 106.3 in. (2700 mm) width, which provides bypass back feed protective contractor option and support both top and bottom cable access.

3.7.2 Moving the Cabinet



WARNING! Risk of improper handling. Can cause equipment damage, injury, or death. Use only lifting equipment that is rated for the unit weight by an OSHA-certified rating organization.



AVERTISSEMENT! Risque de mauvaise manipulation. Peut causer des dommages à l'équipement, des blessures ou la mort. Utilisez uniquement des équipements de levage dont la capacité est adaptée au poids de l'unité, selon une organisation de notation certifiée par l'OSHA.



CAUTION: The center of gravity of the UPS cabinet is high, avoid falling over during the cabinet movement.



CAUTION: Vertical hanging of cabinet is prohibited.

The UPS cabinet presents a tipping hazard. Do not tilt the cabinet more than 15 degrees from vertical while transportation.

Ensure that the UPS weight is within the designated surface weight loading of any lifting equipment. See **Table 12.2** on page 128 for weight of the UPS.

The Vertiv™ PowerUPS 9000 1250 kVA 415 V Modular UPS cabinet can be moved by forklift or other similar lifting equipment.

3.7.3 Clearance

Provide at least minimum clearance required by the Vertiv™ PowerUPS 9000 1250 kVA 415 V Modular UPS, including 47.24 in. (1200 mm) in front, to permit routine tightening power terminals within the UPS and free passage for personnel with the door fully opened.

For the top fan airflow UPS, there are no ventilation grilles on the sides or back of the UPS, the UPS can be placed against the wall directly if there is no seismic anchoring. If the floor anchoring system used, up to 5 in. (127 mm) may be required in the rear of the UPS. Leave a minimum of 24 unobstructed inches (670 mm) between the UPS and any obstructions (conduit, cable trough, or ceiling). Vertiv recommends against using air conditioning or other systems that blow air across the top of the unit.

Figure 3.5 Clearances

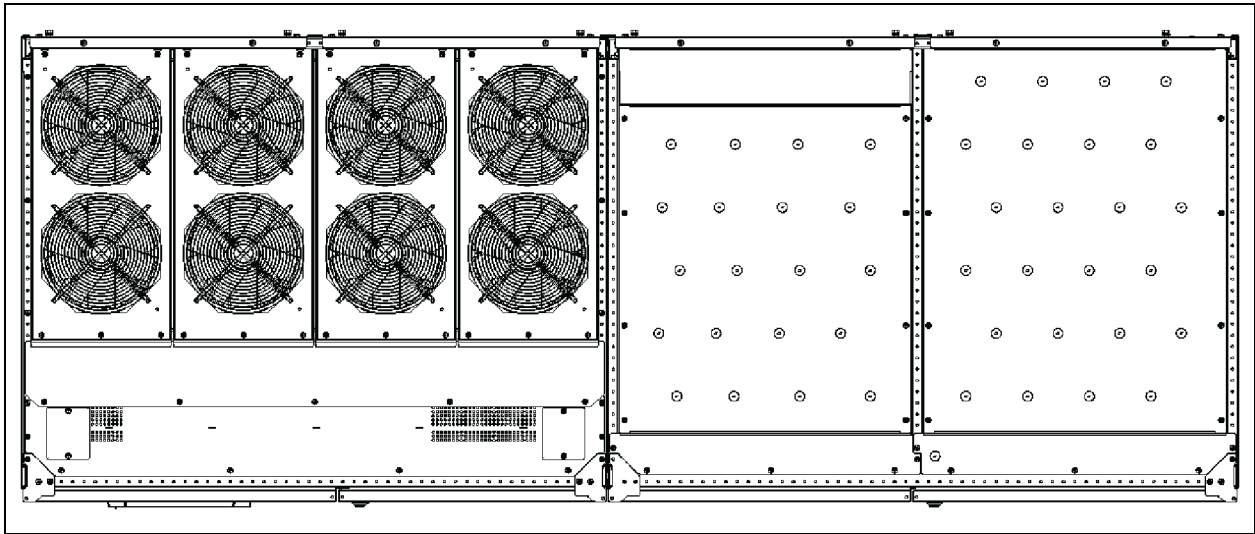

3.7.4 Cable Access

Cables can enter the Vertiv PowerUPS 9000 1250 kVA 415 V Modular UPS from both top and bottom.

Some plates have factory punched holes and others are designed to allow the personnel to punch holes for fitting and securing the conduit. Once the conduit holes are punched, these plates should be reattached to the UPS. The conduit size and wiring method must be in accordance with all local, regional, and national codes and regulations, including NEC ANSI/NFPA 70.

NOTE: Remove the plates from the UPS before drilling or punching for cable access.

NOTE: When installing the UPS, the customer must provide a disconnect with over current protection at the output of the UPS.

3.8 Installation

NOTE: When installing cables for full system capacity, it is crucial to plan carefully to ensure all cable lugs are properly landed. It is advisable to follow the installation guidelines outlined in **Figure 3.6** below. A combination of both top and bottom feeds is also acceptable.

Figure 3.6 Cable Entry Locations

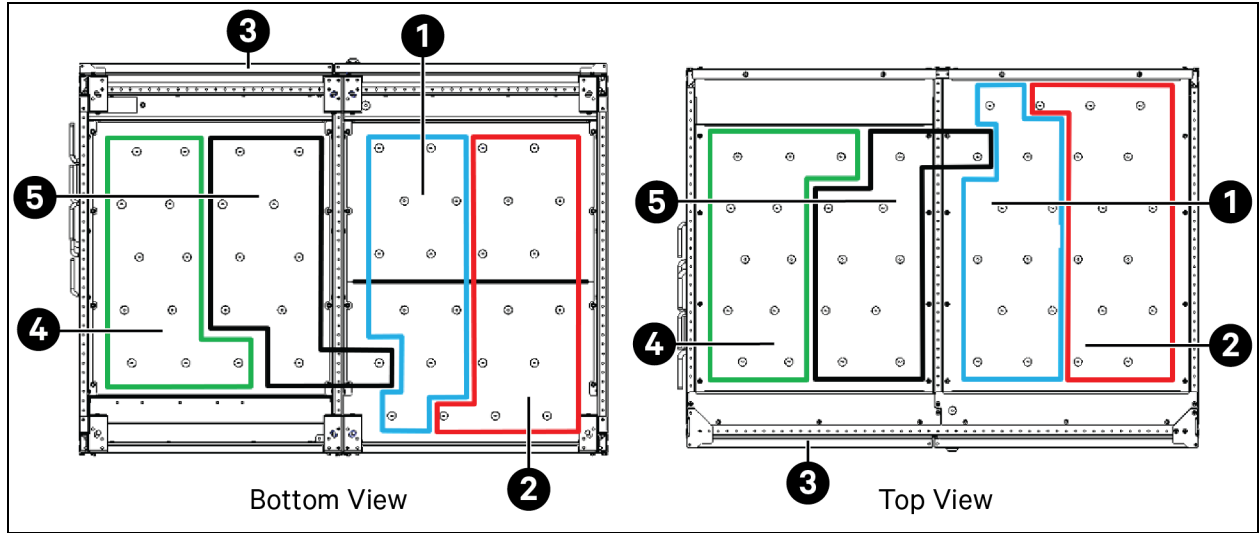

Item	Description	Item	Description
1	Bypass module input	4	Battery input
2	Power module input	5	Output
3	Front		

3.9 Module Components Introduction

3.9.1 Power Module Components

Figure 3.7 Vertiv™ PM125 Power Module Installation Indicators and Controls for 415 V UPS

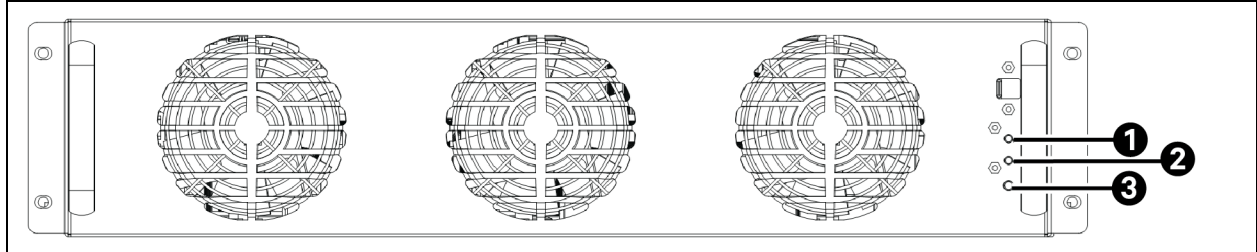

Item	Description
1	Fault LED
2	Run LED
3	Battery cold start switch (Battery cold start switch has no function on UL models).

The Fault LED illuminates red when the Vertiv™ Power Module Assembly has a problem.

The Run LED illuminates green when the Vertiv™ Power Module Assembly is operating normally.

Table 3.3 LED Indications

LED Status	Indication
Run LED (Green)	
Flashing Green	The inverter is starting but has no output yet.
Constant Green	The inverter has started to supply power.
Off	The inverter has started to supply power. The inverter has not started up.
Fault LED (Red)	
Constant Red	Auxiliary power failure (15 V or 24 V), rectifier over temperature, rectifier failure (including battery SCR short circuit), battery converter failure, soft start failure, main circuit back feed, abnormal input current, inverter failure, output short circuit, bypass SCR short circuit fault, inverter relay short circuit fault, abnormal bus voltage, module not ready, module ID out of range and duplicated module ID.
Flashing Red	Charger failure, abnormal main circuit voltage, abnormal main circuit frequency, main circuit under voltage, main circuit reverse phase, battery unavailable, reverse battery, input zero-loss, current sharing failure, module overload, inverter relay disconnection fault, bypass SCR disconnection fault and input fuse blown.
Off	No above failures or alarms.

3.9.2 Bypass Module Component

Figure 3.8 Vertiv™ Bypass Module Installation Indicators for 415 V UPS

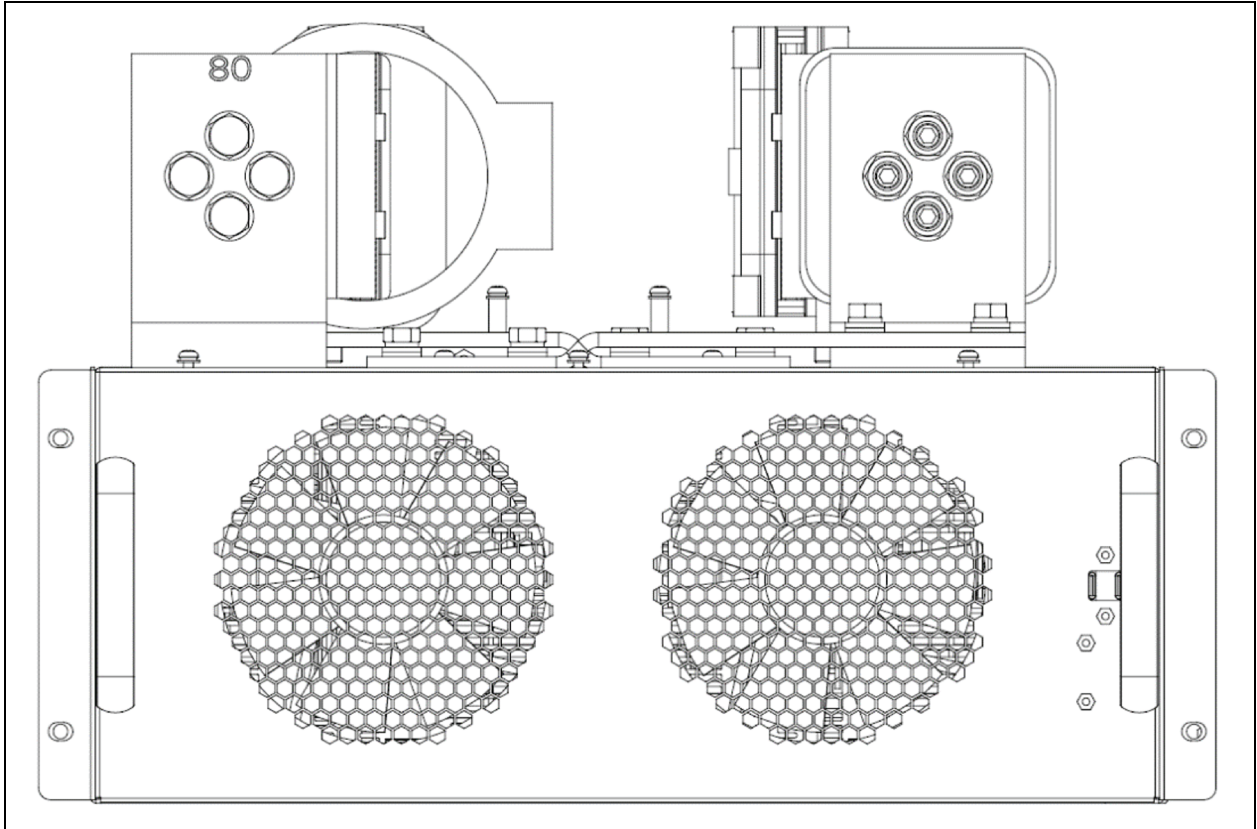

3.9.3 Bypass Control Module Component

Figure 3.9 Vertiv™ Bypass Control Module Installation Indicators for 415 V UPS

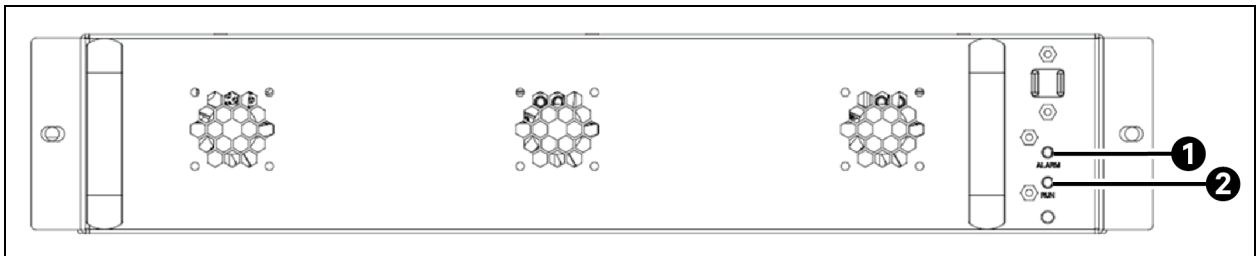

Item	Description
1	Fault LED
2	Run LED

The Fault LED illuminates red when the Vertiv™ Bypass Module Assembly has a problem.

The Run LED illuminates green when the Vertiv™ Bypass Module Assembly is operating normally.

For information of LED indication see **Table 3.4** below.

Table 3.4 LED Indications

LED Status	Indication
Run LED (Green)	
Flashing Green	The bypass SCR is turned on
Off	The bypass SCR is turned off
Fault LED (Red)	
Constant Red	There is an alarm on the bypass, the bypass monCAN is abnormal
Flashing Red	Bypass fault, EPO, output disabled, unauthorized, module digital signal processor (DSP) not running
Off	No above failures or alarms

3.9.4 Control Module Component

The control module has three Vertiv™ Liebert® IntelliSlot™ interface card bays and connections for optional ancillary cabinets and for other options.

Figure 3.10 Communication and Control Panel Layout

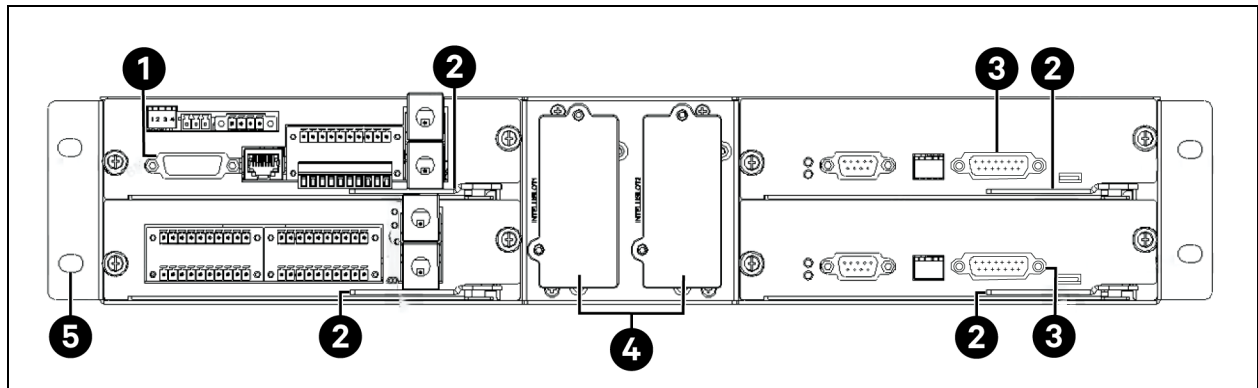

Item	Description	Item	Description
1	Human machine interface (HMI)	4	Vertiv Liebert IntelliSlot Bays 1 and 2
2	Ready switch	5	Screw holes
3	Parallel communication port		

NOTE: See **Figure 4.7** on page 48 through **Figure 4.13** on page 55 for details.

3.10 Installation Drawings

Figure 3.11 Schematic Diagram of Installing 415 V UPS

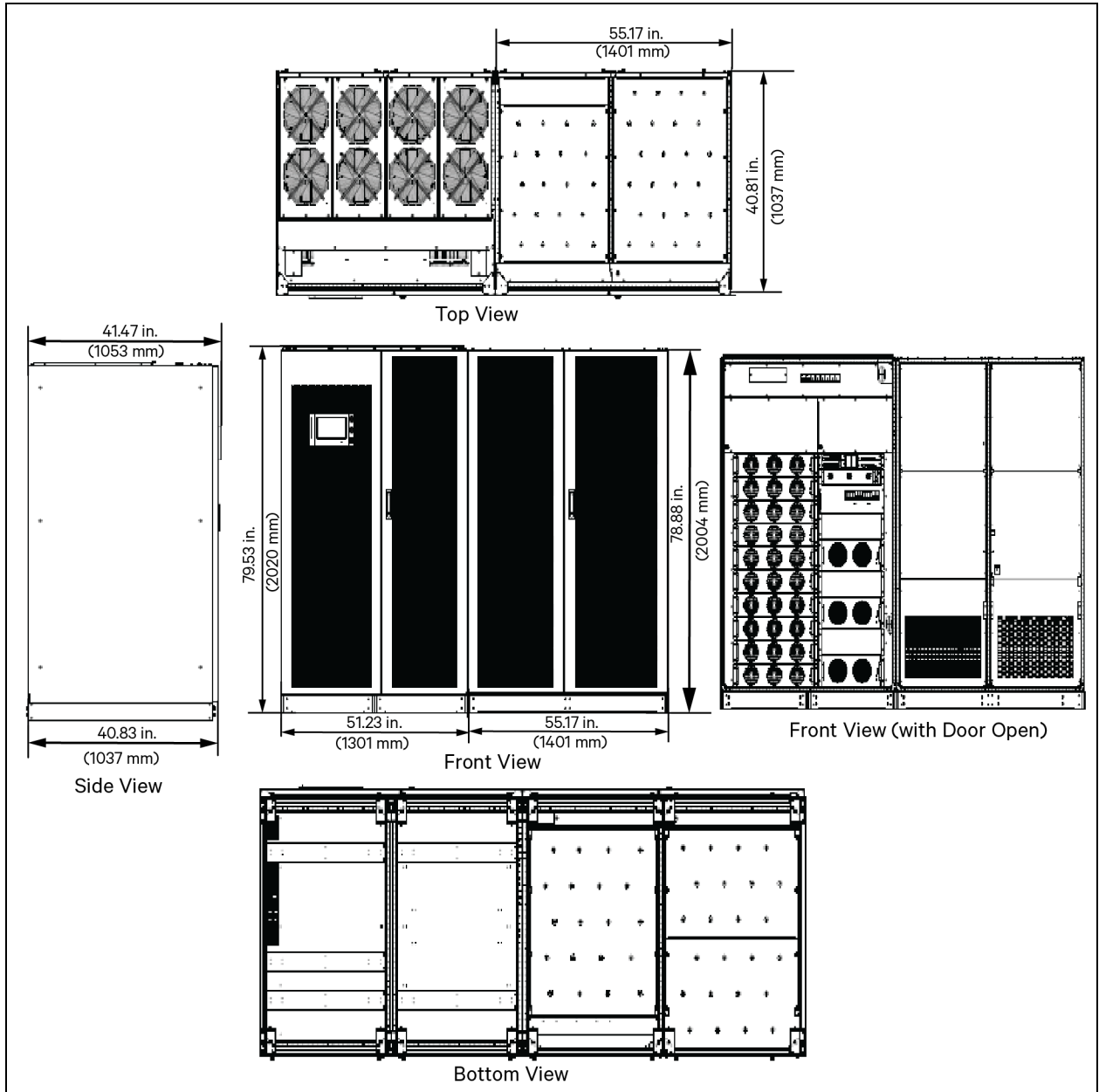

4 Electrical Installation

This chapter describes the electrical installation of the Vertiv™ PowerUPS 9000 1250 kVA 415 V Modular UPS.

After completing the mechanical installation of the UPS, it is necessary to connect the power cable and signal cable of the UPS. All signal cables must run separate from power cables in metal conduits or metal ducts that are electrically bonded to the metalwork of the cabinets to which they are connected. All signal cabling must be shielded.



WARNING! Risk of electric shock. Can cause equipment damage, physical injury, or death. Before connecting input power to the Vertiv PowerUPS 9000 1250 kVA 415 V Modular UPS, ensure that you are aware of the location and operation of the overcurrent protection devices that connect the UPS input/bypass supply to the power distribution panel. Deenergize and lockout or tagout all incoming high and low voltage power circuits before installing cables or making any electrical connections.



AVERTISSEMENT! Risque de décharge électrique pouvant entraîner des dommages matériels, des blessures et même la mort. Avant de procéder au branchement de l'alimentation d'entrée du système de Liebert®, veuillez à prendre connaissance de l'emplacement et du fonctionnement des dispositifs de protection de surintensité qui raccordent l'alimentation d'entrée ou de dérivation du système ASC au panneau de distribution électrique. Coupez l'alimentation et appliquez le verrouillage ou l'étiquetage à tous les circuits d'alimentation haute tension et basse tension avant d'installer les câbles ou d'effectuer tout autre branchement électrique.

4.1 Power Cable Wiring

4.1.1 System Configuration

The main factors affecting the choice and size of cable are voltage, current (also considering overcurrent), room temperature and conditions of installation of the cable. Refer to ANSI/NFPA 70.

The power cables of the system must be sized as follows:

- **UPS input cables:** The UPS input cables must be sized for the maximum input current, including the maximum battery charge current, see **Table 4.1** on the next page.
- **UPS bypass and output cables:** The UPS bypass and output cables must be sized for the nominal output or bypass current, see **Table 4.1** on the next page.
- **Battery cables:** Each UPS connects to its battery through the two cables connecting to the positive pole and negative pole. The cable size of the battery cable differs with the UPS power ratings, provided that it meets the battery discharge current requirement when the battery discharges to near EOD voltage, as shown in **Table 4.1** on the next page.

4.1.2 Maximum Steady State AC and DC Currents

The power cables must be selected in accordance with current and voltage values as given in **Table 4.1** below as well as local wiring regulations and environmental conditions (temperature and physical media).

NOTE: The cables used must be in accordance with NEC ANSI/NFPA 70. Cable sizes should be suitable for operation at a maximum temperature of 104 °F (40 °C).

Table 4.1 Maximum Steady State AC and DC Currents for Vertiv™ PowerUPS 9000 1250 kVA 415 V Modular UPS 4-Wire System

UPS Power (kVA)	Rated Current (A)				Bus Stud Bolt/Nut Specification	
	Maximum Input Current ¹	Output Current ² at Full Load	Bypass Current ² at Full Load	Battery Discharge ³ and Current (+, -, N) at Rated Battery Voltage	Input, Battery, Output, Bypass/PE Cable	Recommended Torque (Nm)
625	1128	870	870	1625	M12	54±10%
750	1353	1044	1044	1933	M12	54±10%
800	1444	1113	1113	2080	M12	54±10%
875	1579	1218	1218	2275	M12	54±10%
1000	1804	1392	1392	2599	M12	54±10%
1100	1985	1566	1566	2859	M12	54±10%
1125	1766	1353	1353	2900	M12	54±10%
1200	2165	1670	1670	3119	M12	54±10%
1250	2255	1739	1739	3249	M12	54±10%

¹ Maximum input current is calculated according to the low voltage input of 384 V (L-L) and 100% load percentage.

² Maximum output/bypass current is calculated according to the rated voltage and 100% load percentage.

³ The battery discharge current is calculated according to the battery, EOD voltage of 400.8V and 100% load percentage.

4.1.3 Recommended Cross-section Area of UPS Cable

The recommended cross-section area (CSA) of the Vertiv™ PowerUPS 9000 1250 kVA 415 V Modular UPS cable is given in Table 4.2 below to Table 4.5 on page 37.

Table 4.2 Recommended CSA for Vertiv PowerUPS 9000 1250 kVA 415 V Modular UPS 4-Wire System—Rectifier Input

UPS Rating		Voltage (VAC)	Cable Entry	(Type of Conduits) Size of Phase Cables Per Conduit Size of Cable for Ground Per Conduit	
kVA	kW			Copper Conductors	Aluminum Conductors
625	625	415	Top	6 in. to 3 in. (350 kcmil/ph+2x350 kcmil ntrl+3/0 awg gnd)	7 in. to 3 in. (350 kcmil/ph+2x350 kcmil ntrl+250 kcmil gnd)
			Bottom	6 in. to 3.5 in. (350 kcmil/ph+2x350 kcmil ntrl+3/0 awg gnd)	7 in. to 3.5 in. (350 kcmil/ph+2x350 kcmil ntrl+250 kcmil gnd)
750	750	415	Top	7 in. to 3 in. (350 kcmil/ph+2x350 kcmil ntrl+4/0 awg gnd)	8 in. to 3.5 in. (350 kcmil/ph+2x350 kcmil ntrl+350 kcmil gnd)
			Bottom	7 in. to 3.5 in. (350 kcmil/ph+2x350 kcmil ntrl+4/0 awg gnd)	8 in. to 4 in. (350 kcmil/ph+2x350 kcmil ntrl+350 kcmil gnd)
800	800	415	Top	7 in. to 3 in. (350 kcmil/ph+2x350 kcmil ntrl+4/0 awg gnd)	9 in. to 3.5 in. (350 kcmil/ph+2x350 kcmil ntrl+350 kcmil gnd)
			Bottom	7 in. to 3.5 in. (350 kcmil/ph+2x350 kcmil ntrl+4/0 awg gnd)	9 in. to 4 in. (350 kcmil/ph+2x350 kcmil ntrl+350 kcmil gnd)
875	875	415	Top	8 in. to 3 in. (350 kcmil/ph+2x350 kcmil ntrl+4/0 awg gnd)	9 in. to 3.5 in. (350 kcmil/ph+2x350 kcmil ntrl+350 kcmil gnd)
			Bottom	8 in. to 3.5 in. (350 kcmil/ph+2x350 kcmil ntrl+4/0 awg gnd)	9 in. to 4 in. (350 kcmil/ph+2x350 kcmil ntrl+350 kcmil gnd)
1000	1000	415	Top	9 in. to 3 in. (350 kcmil/ph+2x350 kcmil ntrl+250 kcmil gnd)	11 in. to 3.5 in. (350 kcmil/ph+2x350 kcmil ntrl+400 kcmil gnd)
			Bottom	9 in. to 3.5 in. (350 kcmil/ph+2x350 kcmil ntrl+250 kcmil gnd)	11 in. to 4 in. (350 kcmil/ph+2x350 kcmil ntrl+400 kcmil gnd)
1100	1100	415	Top	10 in. to 3 in. (350 kcmil/ph+2x350 kcmil ntrl+250 kcmil gnd)	12 in. to 3.5 in. (350 kcmil/ph+2x350 kcmil ntrl+400 kcmil gnd)
			Bottom	10 in. to 3.5 in. (350 kcmil/ph+2x350 kcmil ntrl+250 kcmil gnd)	12 in. to 4 in. (350 kcmil/ph+2x350 kcmil ntrl+400 kcmil gnd)

Table 4.2 Recommended CSA for Vertiv PowerUPS 9000 1250 kVA 415 V Modular UPS 4-Wire System—Rectifier Input (continued)

UPS Rating		Voltage (VAC)	Cable Entry	(Type of Conduits) Size of Phase Cables Per Conduit Size of Cable for Ground Per Conduit	
kVA	kW			Copper Conductors	Aluminum Conductors
1125	1125	415	Top	10 in. to 3.5 in. (350 kcmil/ph+2x350 kcmil ntrl+350 kcmil gnd)	12 in. to 3.5 in. (350 kcmil/ph+2x350 kcmil ntrl+600 kcmil gnd)
			Bottom	10 in. to 4 in. (350 kcmil/ph+2x350 kcmil ntrl+350 kcmil gnd)	12 in. to 4 in. (350 kcmil/ph+2x350 kcmil ntrl+600 kcmil gnd)
1200	1200	415	Top	10 in. to 3.5 in. (350 kcmil/ph+2x350 kcmil ntrl+350 kcmil gnd)	13 in. to 3.5 in. (350 kcmil/ph+2x350 kcmil ntrl+600 kcmil gnd)
			Bottom	10 in. to 4 in. (350 kcmil/ph+2x350 kcmil ntrl+350 kcmil gnd)	13 in. to 4 in. (350 kcmil/ph+2x350 kcmil ntrl+600 kcmil gnd)
1250	1250	415	Top	11 in. to 3.5 in. (350 kcmil/ph+2x350 kcmil ntrl+350 kcmil gnd)	13 in. to 3.5 in. (350 kcmil/ph+2x350 kcmil ntrl+600 kcmil gnd)
			Bottom	11 in. to 4 in. (350 kcmil/ph+2x350 kcmil ntrl+350 kcmil gnd)	13 in. to 4 in. (350 kcmil/ph+2x350 kcmil ntrl+600 kcmil gnd)

NOTE: These values are at ambient temperature of 86 °F (30 °C).

Table 4.3 Recommended CSA for Vertiv™ PowerUPS 9000 1250 kVA 415 V Modular UPS 4-Wire System—Bypass Input

UPS Rating		Voltage (VAC)	Cable Entry	(Type of Conduits) Size of Phase Cables Per Conduit Size of Cable for Ground Per Conduit	
kVA	kW			Copper Conductors	Aluminum Conductors
625	625	415	Top	4 in. to 3 in. (350 kcmil/ph+2x350 kcmil ntrl+2/0 awg gnd)	5 in. to 3 in. (350 kcmil/ph+2x350 kcmil ntrl+4/0 awg gnd)
			Bottom	4 in. to 3.5 in. (350 kcmil/ph+2x350 kcmil ntrl+2/0 awg gnd)	5 in. to 3.5 in. (350 kcmil/ph+2x350 kcmil ntrl+4/0 awg gnd)
750	750	415	Top	5 in. to 3 in. (350 kcmil/ph+2x350 kcmil ntrl+3/0 awg gnd)	6 in. to 3 in. (350 kcmil/ph+2x350 kcmil ntrl+250 kcmil gnd)
			Bottom	5 in. to 3.5 in. (350 kcmil/ph+2x350 kcmil ntrl+3/0 awg gnd)	6 in. to 3.5 in. (350 kcmil/ph+2x350 kcmil ntrl+250 kcmil gnd)
800	800	415	Top	6 in. to 3 in. (350 kcmil/ph+2x350 kcmil ntrl+3/0 awg gnd)	7 in. to 3 in. (350 kcmil/ph+2x350 kcmil ntrl+250 kcmil gnd)
			Bottom	6 in. to 3.5 in. (350 kcmil/ph+2x350 kcmil ntrl+3/0 awg gnd)	7 in. to 3.5 in. (350 kcmil/ph+2x350 kcmil ntrl+250 kcmil gnd)

Table 4.3 Recommended CSA for Vertiv™ PowerUPS 9000 1250 kVA 415 V Modular UPS 4-Wire System—Bypass Input (continued)

UPS Rating		Voltage (VAC)	Cable Entry	(Type of Conduits)	
kVA	kW			Size of Phase Cables Per Conduit	Size of Cable for Ground Per Conduit
				Copper Conductors	Aluminum Conductors
875	875	415	Top	6 in. to 3 in. (350 kcmil/ph+2x350 kcmil ntrl+4/0 awg gnd)	7 in. to 3.5 in. (350 kcmil/ph+2x350 kcmil ntrl+350 kcmil gnd)
			Bottom	6 in. to 3.5 in. (350 kcmil/ph+2x350 kcmil ntrl+4/0 awg gnd)	7 in. to 4 in. (350 kcmil/ph+2x350 kcmil ntrl+350 kcmil gnd)
1000	1000	415	Top	7 in. to 3 in. (350 kcmil/ph+2x350 kcmil ntrl+4/0 awg gnd)	8 in. to 3.5 in. (350 kcmil/ph+2x350 kcmil ntrl+350 kcmil gnd)
			Bottom	7 in. to 3.5 in. (350 kcmil/ph+2x350 kcmil ntrl+4/0 awg gnd)	8 in. to 4 in. (350 kcmil/ph+2x350 kcmil ntrl+350 kcmil gnd)
1100	1100	415	Top	8 in. to 3 in. (350 kcmil/ph+2x350 kcmil ntrl+4/0 awg gnd)	9 in. to 3.5 in. (350 kcmil/ph+2x350 kcmil ntrl+350 kcmil gnd)
			Bottom	8 in. to 3.5 in. (350 kcmil/ph+2x350 kcmil ntrl+4/0 awg gnd)	9 in. to 4 in. (350 kcmil/ph+2x350 kcmil ntrl+350 kcmil gnd)
1125	1125	415	Top	8 in. to 3 in. (350 kcmil/ph+2x350 kcmil ntrl+4/0 awg gnd)	9 in. to 3.5 in. (350 kcmil/ph+2x350 kcmil ntrl+350 kcmil gnd)
			Bottom	8 in. to 3.5 in. (350 kcmil/ph+2x350 kcmil ntrl+4/0 awg gnd)	9 in. to 4 in. (350 kcmil/ph+2x350 kcmil ntrl+350 kcmil gnd)
1200	1200	415	Top	8 in. to 3 in. (350 kcmil/ph+2x350 kcmil ntrl+250 kcmil gnd)	10 in. to 3.5 in. (350 kcmil/ph+2x350 kcmil ntrl+400 kcmil gnd)
			Bottom	8 in. to 3.5 in. (350 kcmil/ph+2x350 kcmil ntrl+250 kcmil gnd)	10 in. to 4 in. (350 kcmil/ph+2x350 kcmil ntrl+400 kcmil gnd)
1250	1250	415	Top	8 in. to 3 in. (350 kcmil/ph+2x350 kcmil ntrl+250 kcmil gnd)	10 in. to 3.5 in. (350 kcmil/ph+2x350 kcmil ntrl+400 kcmil gnd)
			Bottom	8 in. to 3.5 in. (350 kcmil/ph+2x350 kcmil ntrl+250 kcmil gnd)	10 in. to 4 in. (350 kcmil/ph+2x350 kcmil ntrl+400 kcmil gnd)

NOTE: These values are at ambient temperature of 86 °F (30 °C).

Table 4.4 Recommended CSA for Vertiv™ PowerUPS 9000 1250 kVA 415 V Modular UPS 4-Wire System—Bypass Output

UPS Rating		Voltage (VAC)	Cable Entry	(Type of Conduits)	
kVA	kW			Size of Phase Cables Per Conduit	Size of Cable for Ground Per Conduit
				Copper Conductors	Aluminum Conductors
625	625	415	Top	4 in. to 3 in. (350 kcmil/ph+2x350 kcmil ntrl+2/0 awg gnd)	5 in. to 3 in. (350 kcmil/ph+2x350 kcmil ntrl+4/0 awg gnd)
			Bottom	4 in. to 3.5 in. (350 kcmil/ph+2x350 kcmil ntrl+2/0 awg gnd)	5 in. to 3.5 in. (350 kcmil/ph+2x350 kcmil ntrl+4/0 awg gnd)
750	750	415	Top	5 in. to 3 in. (350 kcmil/ph+2x350 kcmil ntrl+3/0 awg gnd)	6 in. to 3 in. (350 kcmil/ph+2x350 kcmil ntrl+250 kcmil gnd)
			Bottom	5 in. to 3.5 in. (350 kcmil/ph+2x350 kcmil ntrl+3/0 awg gnd)	6 in. to 3.5 in. (350 kcmil/ph+2x350 kcmil ntrl+250 kcmil gnd)
800	800	415	Top	6 in. to 3 in. (350 kcmil/ph+2x350 kcmil ntrl+3/0 awg gnd)	7 in. to 3 in. (350 kcmil/ph+2x350 kcmil ntrl+250 kcmil gnd)
			Bottom	6 in. to 3.5 in. (350 kcmil/ph+2x350 kcmil ntrl+3/0 awg gnd)	7 in. to 3.5 in. (350 kcmil/ph+2x350 kcmil ntrl+250 kcmil gnd)
875	875	415	Top	6 in. to 3 in. (350 kcmil/ph+2x350 kcmil ntrl+4/0 awg gnd)	7 in. to 3.5 in. (350 kcmil/ph+2x350 kcmil ntrl+350 kcmil gnd)
			Bottom	6 in. to 3.5 in. (350 kcmil/ph+2x350 kcmil ntrl+4/0 awg gnd)	7 in. to 4 in. (350 kcmil/ph+2x350 kcmil ntrl+350 kcmil gnd)
1000	1000	415	Top	7 in. to 3 in. (350 kcmil/ph+2x350 kcmil ntrl+4/0 awg gnd)	8 in. to 3.5 in. (350 kcmil/ph+2x350 kcmil ntrl+350 kcmil gnd)
			Bottom	7 in. to 3.5 in. (350 kcmil/ph+2x350 kcmil ntrl+4/0 awg gnd)	8 in. to 4 in. (350 kcmil/ph+2x350 kcmil ntrl+350 kcmil gnd)
1100	1100	415	Top	8 in. to 3 in. (350 kcmil/ph+2x350 kcmil ntrl+4/0 awg gnd)	9 in. to 3.5 in. (350 kcmil/ph+2x350 kcmil ntrl+350 kcmil gnd)
			Bottom	8 in. to 3.5 in. (350 kcmil/ph+2x350 kcmil ntrl+4/0 awg gnd)	9 in. to 4 in. (350 kcmil/ph+2x350 kcmil ntrl+350 kcmil gnd)
1125	1125	415	Top	8 in. to 3 in. (350 kcmil/ph+2x350 kcmil ntrl+4/0 awg gnd)	9 in. to 3.5 in. (350 kcmil/ph+2x350 kcmil ntrl+350 kcmil gnd)
			Bottom	8 in. to 3.5 in. (350 kcmil/ph+2x350 kcmil ntrl+4/0 awg gnd)	9 in. to 4 in. (350 kcmil/ph+2x350 kcmil ntrl+350 kcmil gnd)

Table 4.4 Recommended CSA for Vertiv™ PowerUPS 9000 1250 kVA 415 V Modular UPS 4-Wire System—Bypass Output (continued)

UPS Rating		Voltage (VAC)	Cable Entry	(Type of Conduits)	
kVA	kW			Size of Phase Cables Per Conduit	Size of Cable for Ground Per Conduit
				Copper Conductors	Aluminum Conductors
1200	1200	415	Top	8 in. to 3 in. (350 kcmil/ph+2x350 kcmil ntrl+250 kcmil gnd)	10 in. to 3.5 in. (350 kcmil/ph+2x350 kcmil ntrl+400 kcmil gnd)
			Bottom	8 in. to 3.5 in. (350 kcmil/ph+2x350 kcmil ntrl+250 kcmil gnd)	10 in. to 4 in. (350 kcmil/ph+2x350 kcmil ntrl+400 kcmil gnd)
1250	1250	415	Top	8 in. to 3 in. (350 kcmil/ph+2x350 kcmil ntrl+250 kcmil gnd)	10 in. to 3.5 in. (350 kcmil/ph+2x350 kcmil ntrl+400 kcmil gnd)
			Bottom	8 in. to 3.5 in. (350 kcmil/ph+2x350 kcmil ntrl+250 kcmil gnd)	10 in. to 4 in. (350 kcmil/ph+2x350 kcmil ntrl+400 kcmil gnd)

NOTE: These values are at ambient temperature of 86 °F (30 °C).

Table 4.5 Recommended CSA for Vertiv PowerUPS 9000 1250 kVA 415 V Modular UPS 4-Wire System—Battery

UPS Rating		Voltage (VDC)	Cable Entry	(Type of Conduits)	
kVA	kW			Size of Phase Cables Per Conduit	Size of Cable for Ground Per Conduit
				Copper Conductors	Aluminum Conductors
625	625	415	Top	5 in. to 3 in. (600 kcmil/polarity+250 kcmil gnd)	6 in. to 3 in. (600 kcmil/polarity+400 kcmil gnd)
			Bottom	5 in. to 3 in. (600 kcmil/polarity+250 kcmil gnd)	6 in. to 3.5 in. (600 kcmil/polarity+400 kcmil gnd)
750	750	415	Top	5 in. to 3 in. (600 kcmil/polarity+250 kcmil gnd)	6 in. to 3 in. (600 kcmil/polarity+400 kcmil gnd)
			Bottom	5 in. to 3 in. (600 kcmil/polarity+250 kcmil gnd)	6 in. to 3.5 in. (600 kcmil/polarity+400 kcmil gnd)
800	800	415	Top	6 in. to 3 in. (600 kcmil/polarity+350 kcmil gnd)	7 in. to 3 in. (700 kcmil/polarity+600 kcmil gnd)
			Bottom	6 in. to 3 in. (600 kcmil/polarity+350 kcmil gnd)	7 in. to 3.5 in. (700 kcmil/polarity+600 kcmil gnd)
875	875	415	Top	6 in. to 3 in. (600 kcmil/polarity+350 kcmil gnd)	7 in. to 3 in. (700 kcmil/polarity+600 kcmil gnd)
			Bottom	6 in. to 3 in. (600 kcmil/polarity+350 kcmil gnd)	7 in. to 3.5 in. (700 kcmil/polarity+600 kcmil gnd)
1000	1000	415	Top	8 in. to 3 in. (500 kcmil/polarity+500 kcmil gnd)	8 in. to 3 in. (700 kcmil/polarity+600 kcmil gnd)
			Bottom	8 in. to 3 in. (500 kcmil/polarity+500 kcmil gnd)	8 in. to 3.5 in. (700 kcmil/polarity+600 kcmil gnd)

Table 4.5 Recommended CSA for Vertiv PowerUPS 9000 1250 kVA 415 V Modular UPS 4-Wire System—Battery (continued)

UPS Rating		Voltage (VDC)	Cable Entry	(Type of Conduits)	
kVA	kW			Size of Phase Cables Per Conduit	Size of Cable for Ground Per Conduit
				Copper Conductors	Aluminum Conductors
1100	1100	415	Top	8 in. to 3 in. (500 kcmil/polarity+500 kcmil gnd)	8 in. to 3 in. (700 kcmil/polarity+600 kcmil gnd)
			Bottom	8 in. to 3 in. (500 kcmil/polarity+500 kcmil gnd)	8 in. to 3.5 in. (700 kcmil/polarity+600 kcmil gnd)
1125	1125	415	Top	8 in. to 3 in. (500 kcmil/polarity+500 kcmil gnd)	8 in. to 3 in. (700 kcmil/polarity+600 kcmil gnd)
			Bottom	8 in. to 3 in. (500 kcmil/polarity+500 kcmil gnd)	8 in. to 3.5 in. (700 kcmil/polarity+600 kcmil gnd)
1200	1200	415	Top	9 in. to 3 in. (750 kcmil/polarity+500 kcmil gnd)	11 in. to 3 in. (700 kcmil/polarity+750 kcmil gnd)
			Bottom	9 in. to 3.5 in. (750 kcmil/polarity+500 kcmil gnd)	11 in. to 3.5 in. (700 kcmil/polarity+750 kcmil gnd)
1250	1250	415	Top	9 in. to 3 in. (750 kcmil/polarity+500 kcmil gnd)	11 in. to 3 in. (700 kcmil/polarity+750 kcmil gnd)
			Bottom	9 in. to 3.5 in. (750 kcmil/polarity+500 kcmil gnd)	11 in. to 3.5 in. (700 kcmil/polarity+750 kcmil gnd)

NOTE: These values are at ambient temperature of 86 °F (30 °C).

NOTE: Recommended cable sizes are 194 °F (90 °C) (THW) wire at 86 °F (30 °C) ambient.

NOTE: Refer to NEC recommendations for 104 °F (40 °C) ambient rated conductors.

NOTE: Unless otherwise noted, use copper or aluminum conductors suitable for at least 194 °F (90 °C).

NOTE: Recommended cables and conduits are based on breaker trip setting sized for the maximum continuous rated current for the rectifier input and the nominal current for the bypass and output listed in on the previous page, through on the previous page.

NOTE: Conduit size is based on RNC type conduit for bottom input and EMT-type conduit for top input.

NOTE: Vertiv recommends that the site planner choose the appropriate cable type based on the installation requirements.

NOTE: These recommendations are for use with 100% rated breakers. For 125% rated breakers, refer to the NEC recommended conduit and cable sizes.

NOTE: Upstream and downstream non-standard recommended breaker settings have their trip adjustment behind a suitable cover in accordance with 240.6© of the NEC.

4.1.4 Recommended Breaker of UPS OPD

NOTE: The branch circuit overcurrent protection breakers used must be in accordance with NEC ANSI/NFPA 70 and the Canadian Electrical Code, Part I, C22.1. A disconnect breaker must be provided which will be used as overcurrent Protection device for AC input, DC input and AC output.

- Remote Feed Breaker (RFB)
- Remote Back-feed Breaker (RBB)
- Maintenance Bypass Breaker (MBB)
- Maintenance Isolation Breaker (MIB)
- Battery Circuit Breaker (BCB)

All recommended breakers are all 125% rated breaker.

NOTE: The maximum available fault DC current is 30 kA.

Table 4.6 Recommended OPD for 415 V 4-Wire System

Model (kVA)	RFB (A)	MIB (A)	RBB (A) and MBB (A)	BCB (A)
625	1500	1150	1150	2100
750	1750	1350	1350	2500
800	1850	1450	1450	2650
875	2050	1600	1600	2900
1000	2300	1800	1800	3300
1100	2550	2000	2000	3600
1125	2600	2050	2050	3700
1200	2750	2150	2150	3950
1250	2900	2250	2250	4100

NOTE: These values are at Ambient Temperature of 86 °F (30 °C).

4.1.5 General Information

The following points are for general guidance only. If there are relevant local regulations, then follow the local regulations:

1. The protective earth cables must be selected in accordance with the AC power failure level, cable length, and protection type. The shortest connection route must be used for the grounding wire connection.
2. The parallel connection of small cables can be used to make easier installation for cables which are carrying large current.
3. The battery cable size must be selected in accordance with the current value given in [Maximum Steady State AC and DC Currents](#) on page 32 and a maximum allowed voltage drop is 2 VDC.
4. Avoid creating the coils to reduce the generation of electromagnetic interference (EMI).
5. Make sure to leave sufficient wiring space before wiring.

4.1.6 Power Cable Connecting Terminal

The rectifier input, bypass input, output, and battery power cables are connected to the respective terminals as specified in the [Power Cable Connection Steps](#) on page 42.

4.1.7 Protective Ground

The protective earth cable is securely connected to the PE input terminal through the fixing bolt. See [Power Cable Connection Steps](#) on page 42 for more details. All the cabinets and cable conduits must be grounded according to the local regulations. The grounding wires must be securely fastened to prevent the loosening of the grounding wire tightening screws when the grounding wires are pulled.



WARNING! Failure to ground as required may cause EMI, electric shock, or fire risk.



AVERTISSEMENT! Le défaut de mise à la terre comme requis peut provoquer des interférences électromagnétiques, un choc électrique ou un risque d'incendie.

4.1.8 External Protective Devices

For safety concerns, it is necessary to install the external circuit breakers or other protective devices for the input and battery of the UPS system. This section provides generic practical information for the qualified installation engineers due to the different specific installations. The qualified installation engineers must be knowledgeable about local regulatory wiring standards on the equipment to be installed.

Rectifier and bypass input supply of the UPS:

1. Input overcurrent and short circuit protection.

Install suitable protective devices in the distribution line of the incoming mains supply, considering the power cable current carrying capacity, system overload capacity, as shown in **Table 12.5** on page 130 and the short circuit capability of the upstream power distribution. The protective devices should provide functions such as the overcurrent protection, short circuit protection, isolation protection and tripping upon backfeed.

2. Split bypass configuration.

If the UPS uses split bypass configuration, a separate protective device should be installed respectively on the rectifier input and bypass input in the distribution lines.

3. Ground fault protection.

If the upstream input power supply has a RCD, the transient state and steady state ground leakage current upon the start-up of the UPS must be considered.

The RCCB must meet the following requirements:

- Must be sensitive to the DC unidirectional pulse (class A) of the whole distribution network.
- Must be insensitive to transient state current pulse.
- Must have an average sensitivity, adjustable between 0.3 A to 3 A.

The RCCB symbols are shown in **Figure 4.1** below.

Figure 4.1 RCCB Symbols

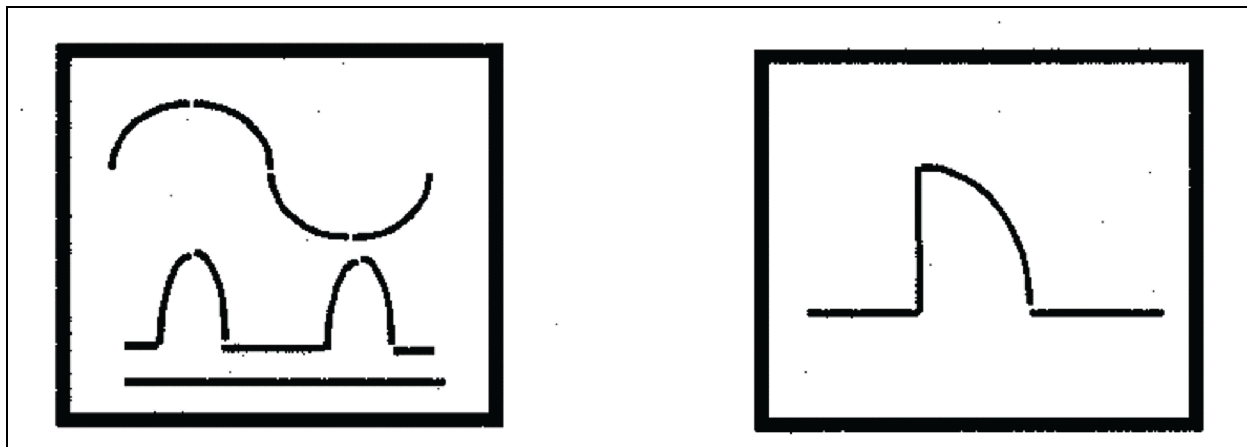

The UPS consist of an internal EMC filter, therefore the protective earth cable's leakage current is less than 3000 mA. It is recommended to verify the RCD sensitivity of the upstream input distribution and the downstream distribution (to the load).

External Battery

If a battery breaker has been installed for protecting the external battery. The battery breaker will provide overcurrent protection, short circuit protection and automatic tripping functions for the external battery.

This battery breaker is important for the battery maintenance and is generally installed near the battery. While some battery manufacturers may not mandate the use of a battery breaker, they typically provide an alternative method for disconnecting power flow, such as a switch or contactor. This disconnect mechanism is used alongside DC-rated fuses to protect against overcurrent and short circuits.

UPS Output

The UPS output distribution must be configured with a protective device. The protective device must be different from the input distribution protection switch and able to provide overload protection, as shown in **Table 12.5** on page 130.

NOTE: An IT grid system, 4-pole protective components must be installed for the UPS external input power distribution.

4.1.9 Power Cable Connection Steps

Connection Terminal

See Figure 4.2 below and Figure 4.3 on the facing page for the connection terminals of the 415 V UPS power cable.

Figure 4.2 Power Cable Connection Terminals for 415 V UPS 1250 kVA (without BFD)

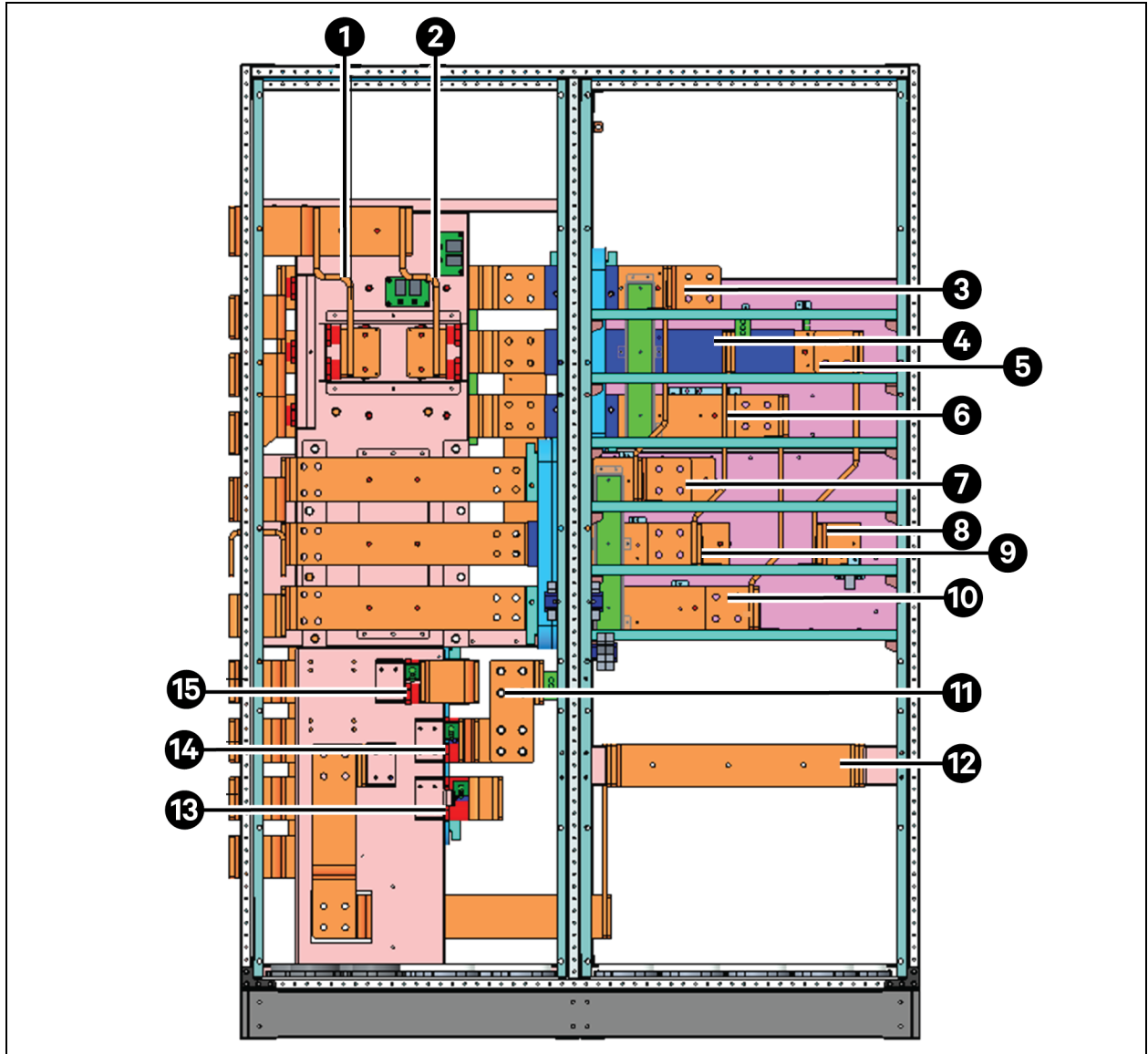

Item	Description	Item	Description	Item	Description	Item	Description
1	BAT +	5	REC-N	9	BYP-B	13	OUT-C
2	BAT -	6	REC-C	10	BYP-C	14	OUT-B
3	REC-A	7	BYP-A	11	OUT-N	15	OUT-A
4	REC-B	8	BYP-N	12	PE		

Figure 4.3 Power Cable Connection Terminals for 415 V UPS 1250 kVA (with BFD)

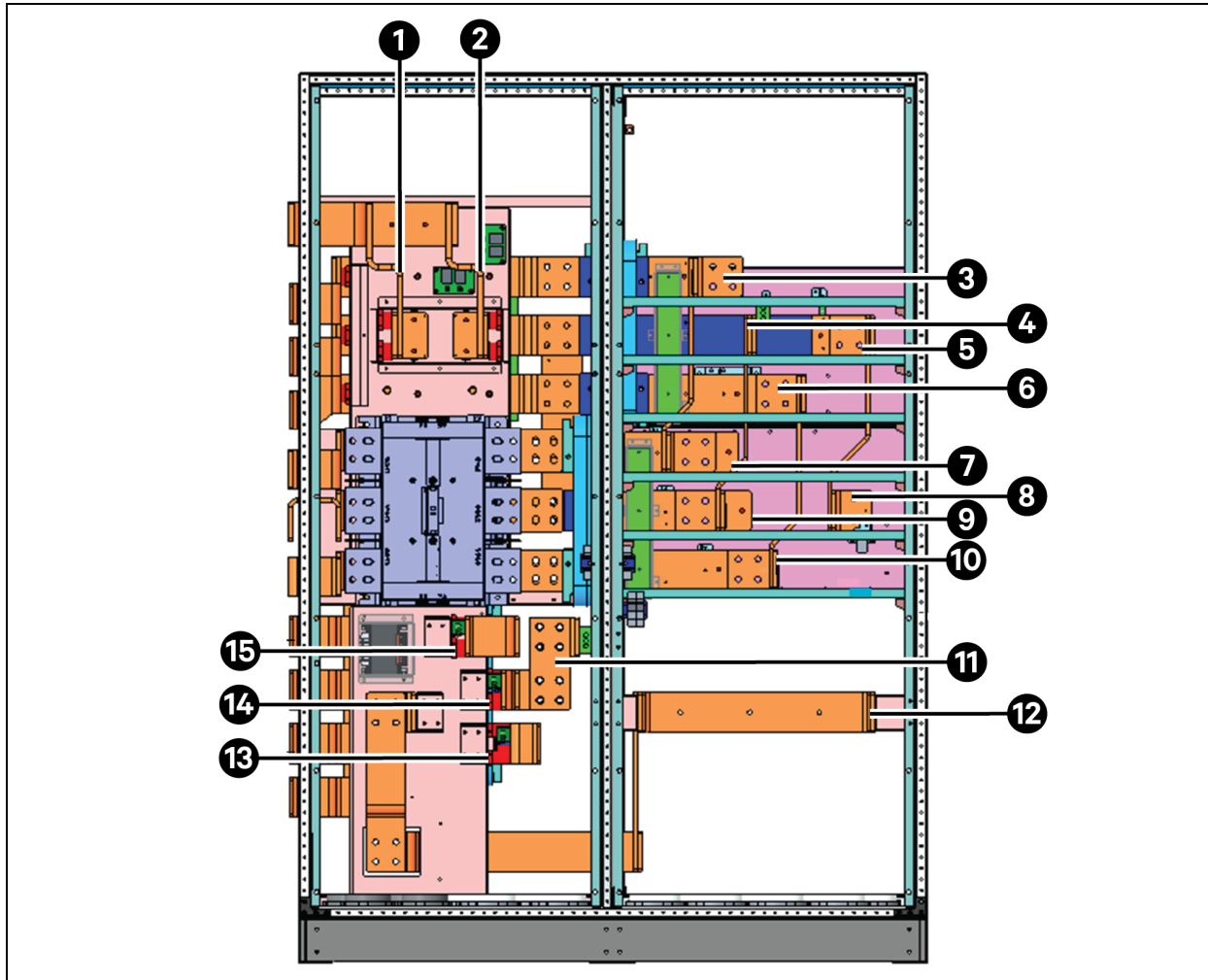

Item	Description	Item	Description
1	BAT +	9	BYP-B
2	BAT -	10	BYP-C
3	REC-A	11	OUT-N
4	REC-B	12	PE
5	REC-N	13	OUT-C
6	REC-C	14	OUT-B
7	BYP-A	15	OUT-A
8	BYP-N		

NOTE: The power cables should be routed through cable conduits to prevent cable damage due to mechanical stress. After that reduce the electromagnetic interference to the surrounding environment.

NOTE: It is necessary to tie and fix the cables when routing the cables inside the cabinets to prevent cable damage because of mechanical stress.

Cabling Procedure



CAUTION: The operations described in this section must be performed by authorized electricians or qualified technical personnel. If you have any difficulties, contact your local Vertiv representative or Vertiv Services.



PRUDENCE: Toutes les opérations décrites dans cette section ne doivent être effectuées que par des électriciens ou des techniciens professionnels dûment formés et qualifiés . En cas de difficultés, communiquez avec Vertiv. Pour obtenir les renseignements de contact, consultez la dernière page de ce manuel.

NOTE: Hydraulic pressure pliers, combinative tools, and piston ring pliers should be used to connect AC wiring.

Once the equipment has been positioned and secured for operation, and the battery and ground lugs have been connected, see [Power Cable Wiring](#) on page 31, and [Installation Drawings](#) on page 30.

To connect the power cables, perform the following steps:

1. Verify that all incoming high and low voltage power circuits are de-energized and locked out or tagged out before installing cables or making any electrical connections.
2. Remove the front I/O panel to gain easier access to the connection of busbars.
3. Connect the facility ground and ancillary ground bus cables to the copper ground busbar. All cabinets in the UPS system must be connected to the user's ground connection.

NOTE: The grounding arrangement must comply with the National Electrical Code and all applicable local codes.

4. Identify and make power connections with incoming cables according to for common bypass and main inputs, connect the AC input supply cables to the UPS input terminals (BYP-A, BYP-B, BYP-C) and tighten the connections to 477.9 lb-in. (54 Nm) (M12 bolt). Ensure correct phase rotation. Refit all protective covers removed for cable installation. For more information, see **Figure 3.6** on page 26.

The UPS supports both top and bottom cable access. See **Figure 4.4** below for details.

NOTE: Conduits are installed on both upper and lower cable entry holes. Follow the conduit wiring access wiring instructions.



WARNING! Risk of electric shock. Can cause equipment damage, personnel injury, or death.
Verify that all external and internal power switches of the UPS are turned off and locked out or tagged out before installing the cables or making any electrical connections. Also, measure the voltages between the UPS terminals and the voltages between the terminals and the earth.



AVERTISSEMENT! Risque de choc électrique. Peut provoquer des dommages à l'équipement, des blessures au personnel ou la mort. Vérifiez que tous les interrupteurs d'alimentation externes et internes de l'onduleur sont éteints et verrouillés ou étiquetés avant d'installer les câbles ou de faire des connexions électriques. Mesurez également les tensions entre les bornes de l'onduleur et les tensions entre les bornes et la terre.

Figure 4.4 Power Cables Wiring Route 415 V 1250 kVA (Top Cable Access)

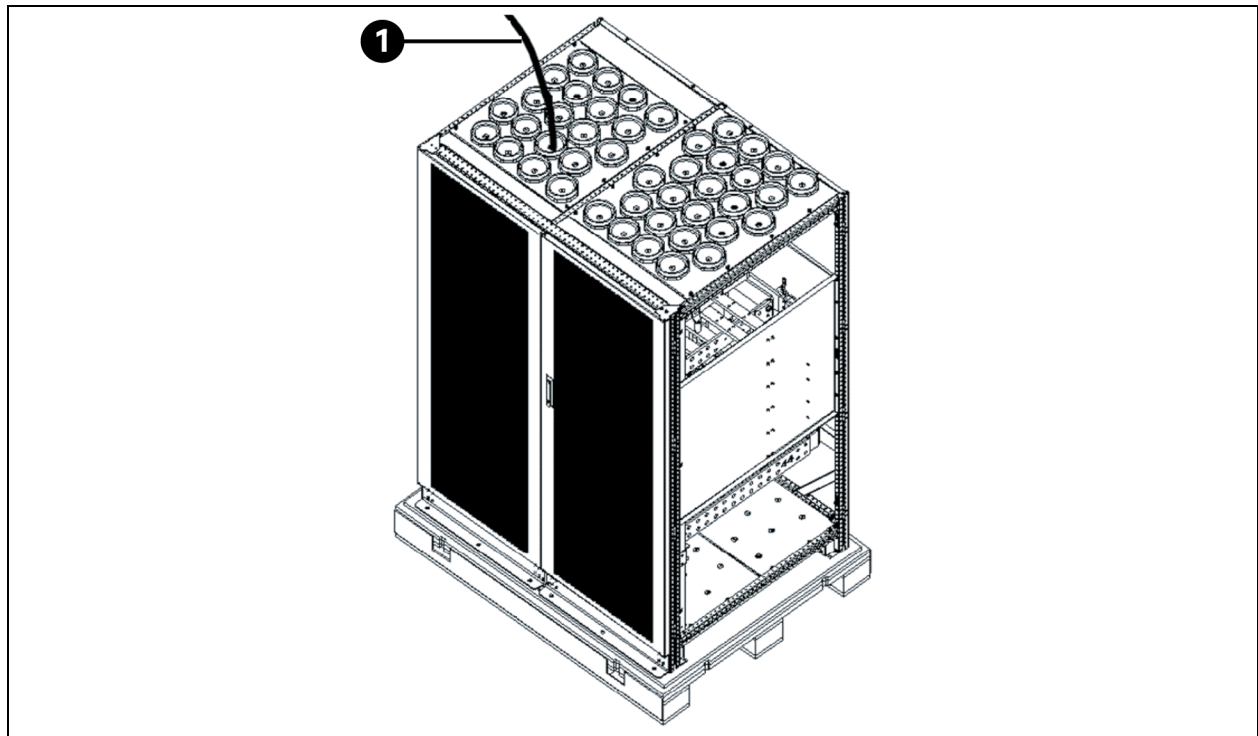

Item	Description
1	Power cable through top cabinet entry plate

Figure 4.5 Power Cables Wiring Route 415 V 1250 kVA (Bottom Cable Access)

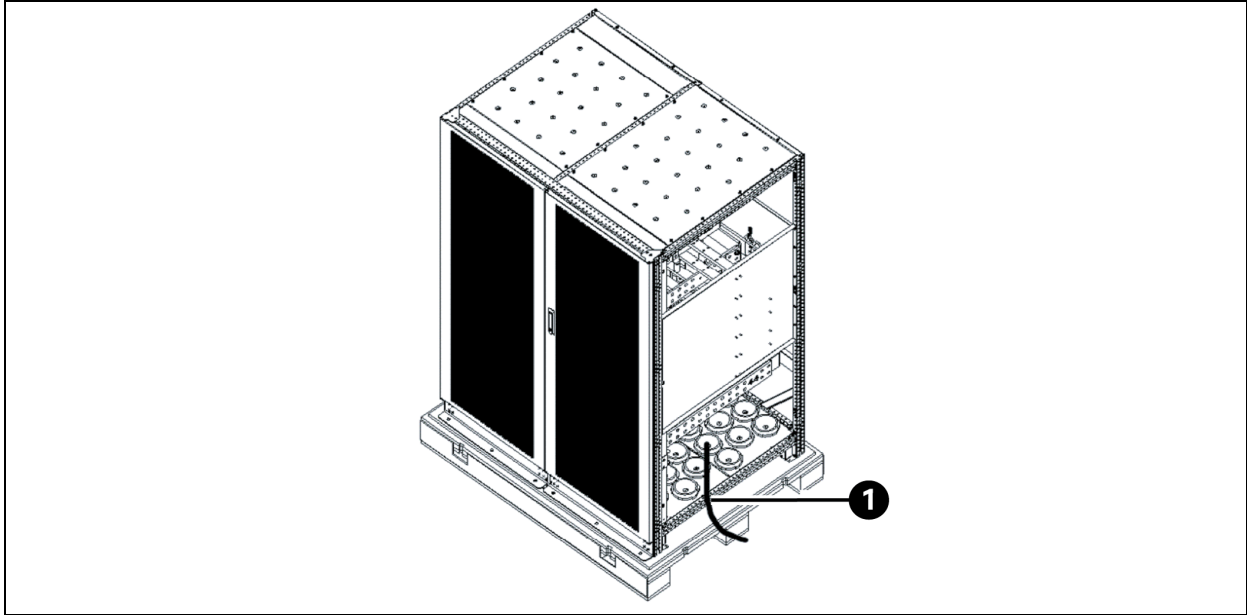

Item	Description
1	Power cable through the bottom cabinet hole.

! **WARNING!** Risk of electric shock or fire. Can cause equipment damage, personnel injury, or death. The earth grounding cable and neutral line connection must comply with the national electrical code and all the applicable local code.

! **AVERTISSEMENT!** Risque de choc électrique ou d'incendie. Peut provoquer des dommages matériels, des blessures au personnel ou la mort. Le câble de mise à la terre et la connexion du fil neutre doivent être conformes au code électrique national et à tous les codes locaux applicables.

Figure 4.6 Conduit Wiring Access

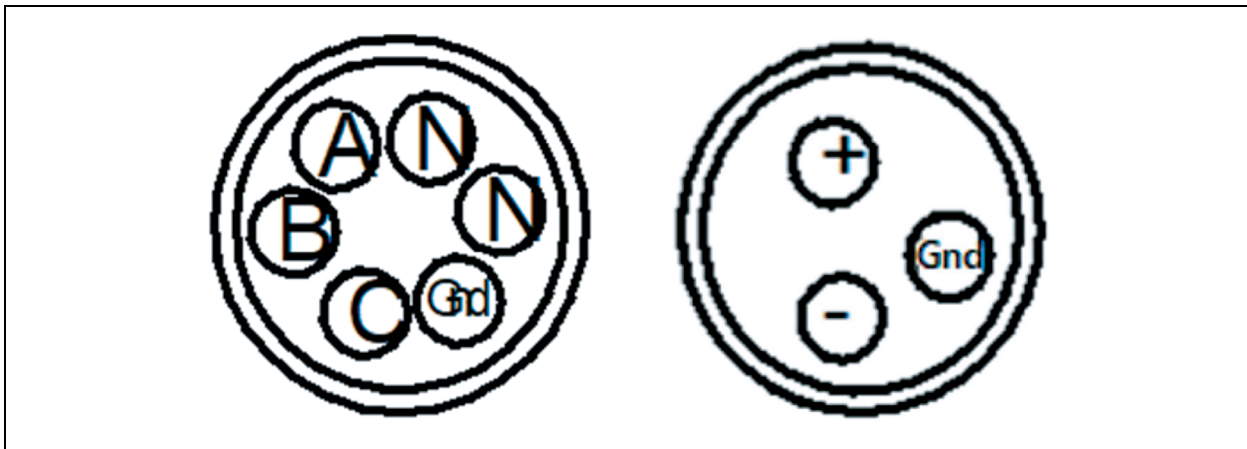

The recommended wiring sequence for UPS is shown in **Figure 3.6** on page 26.

Common Input Connection

For common bypass and main inputs, connect the AC input supply cables to the UPS input terminals (BYP-A, BYP-B, BYP-C) and tighten the connections to 477.9 lb-in. (54 Nm) (M12 bolt). Ensure correct phase rotation. See **Figure 4.2** on page 42 and **Figure 4.3** on page 43 for additional details.

Dual Bypass Connections

If a split bypass configuration is used, connect the AC input supply cables to the rectifier input terminals (REC-A, REC-B, REC-C) and the AC bypass supply cables to the bypass input terminals (BYP-A, BYP-B, BYP-C) and tighten the connections according to [Power Cable Connection Steps](#) on page 42.

NOTE: For split bypass operation, ensure that the busbars between bypass and rectifier inputs are removed.

Output System Connections Ensure Correct Phase Rotation

To connect the system output cables, perform the following steps:

1. Connect the system output cables between the UPS output busbars (OUT-A, OUT-B, OUT-C terminals) and the critical load and tighten the connections according to [Power Cable Connection Steps](#) on page 42.



WARNING! Risk of electrical shock and arc flash. Can cause property damage, injury and death. If the load equipment will not be ready to accept power when the commissioning engineer arrives, ensure that the system output cables are safely isolated.



AVERTISSEMENT! Risque de décharge électrique pouvant causer des blessures graves, voire mortelles. Si les équipements branchés ne sont pas prêts à être alimentés à l'arrivée de l'ingénieur de mise en service, assurez-vous que les bornes des câbles de sortie du système soient isolées de façon sécuritaire.

NOTE: Observe the battery cable polarity. Be sure that the battery connections, if any, are made with the correct polarity.

2. Refit all protective covers removed for cable installation.

Connecting Batteries

To connect the batteries to the UPS, perform the following steps:

1. Ensure correct polarity of the connections from the battery cabinet to the battery input terminals (BAT+, BAT-) in the UPS cabinet, that is, (BAT+) to (+) and (BAT-) to (-). Do not reconnect these links and do not close the battery breaker before authorized to do so by the service engineer.
2. Refit all protective covers removed for cable installation.

NOTE: After connection, make sure to seal the cable entry hole on the cabinet.

4.2 Wiring of Signal Cable

4.2.1 Overview

Based on the site’s specific requirements, the Vertiv™ PowerUPS 9000 1250 kVA 415 V Modular UPS can require an auxiliary connection to manage the battery system management (including the external battery switch), communicate with a personal computer, provide alarm signal to the external devices, for the remote emergency power off (REPO) or provide bypass back feed circuit breaker signal and parallel communication. These functions are performed through the communication box in the UPS cabinet. The communication box provides the ports as shown in **Figure 4.7** below.

Figure 4.7 Overview of Communication Ports

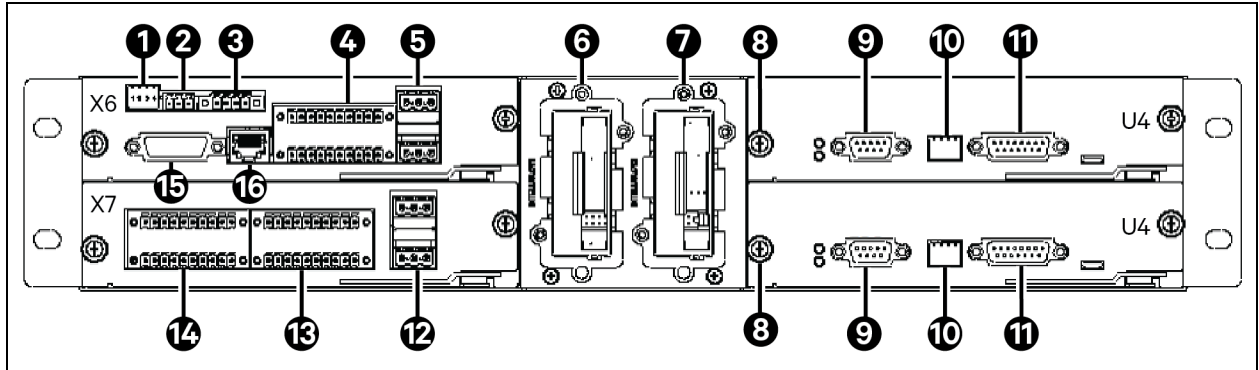

Item	Description	Item	Description
1	X6 SW1	9	U4 LBS synchronize signal port
2	X6 RS-485 (for internal use)	10	U4 SW parallel CAN for the terminating resistors
3	X6 REPO port	11	U4 parallel communication port
4	X6 J3: BCB and I/O dry contact ports	12	X7 J3: Other programmable output dry contact port
5	X6 J22: Backfeed port	13	X7 J2: I/O dry contact ports
6	Vertiv™ Liebert® IntelliSlot™ 1	14	X7 J1: BCB and I/O dry contact ports
7	Vertiv Liebert IntelliSlot 2	15	X6 HMI port
8	Screw (quantity is 8)	16	X6 BATT: Battery temperature or BMS communication port

NOTE: The screws should be tightened after each board is inserted, as shown in **Figure 4.7** above, to maintain proper grounding.

4.2.2 Input/Output Dry Contact Port X6 J3

The schematic diagram of dry contact port J3 is shown in **Figure 4.8** below and the ports are described in **Table 4.7** below. The input dry contacts of this series provide 24 V/10 mA signals, and the output dry contacts are relay contacts that can accept 24 V/1 A signals. The BCB drive signal can provide 12 V/10 mA signal.

Figure 4.8 Dry Contact Port J3

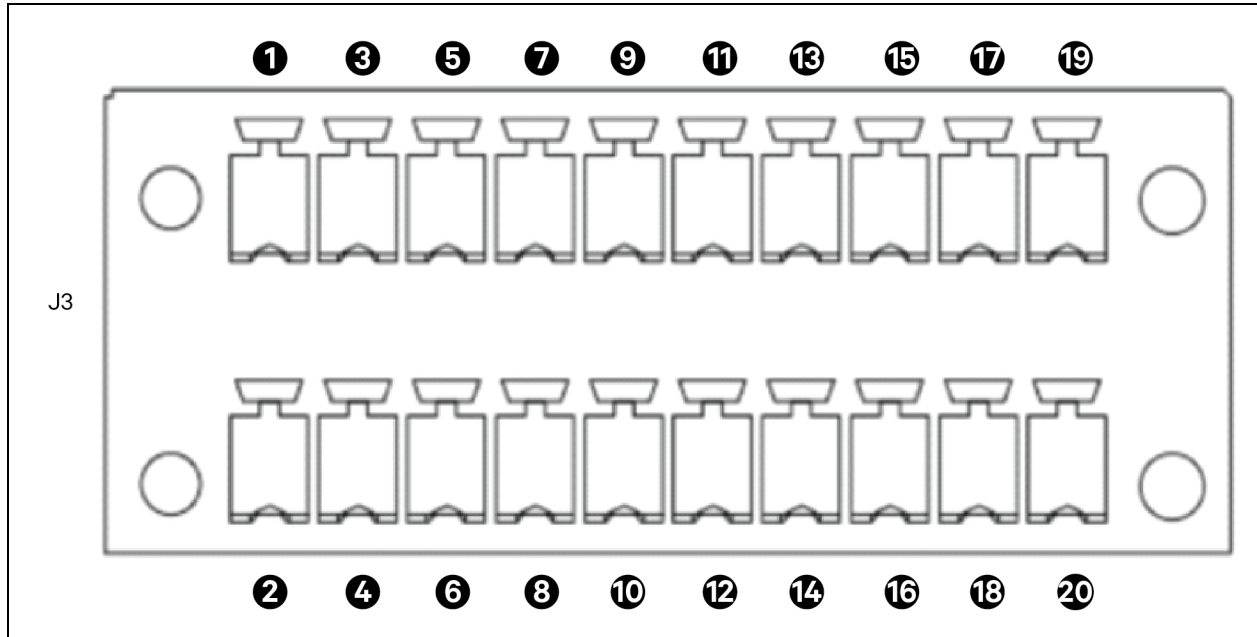

Table 4.7 Description of Dry Contact Port J3

Pin	Name	Meanings	Pin	Name	Meanings
1	Dry in	Input dry contact can be defined, the default setting is BCB power abnormal, NC contact.	2	BCB drive 1	12 V Drive for BCB, or reserved for bypass input breaker (BIB) & PSU kit, the default setting is BCB1&5&9 Drive. (The corresponding GND shall be connected to pin 6.)
3	GND		4	Dry in	Input dry contact can be defined, the default setting is BCB1 status, branch BCB online dry contact free to enable, NO contact.
5	Dry in	Input dry contact can be defined, the default setting is charger off, NO contact.	6	GND	Input dry contact can be defined, the default setting is BCB5 status, NO contact.
7	GND		8	Dry in	
9	NO	Output dry contact can be defined, the default setting is summary alarm.	10	GND	Input dry contact can be defined, the default setting is battery grounding signal, NO contact.
11	Com1		12	Dry in	
13	NC		14	GND	
15	NO	Output dry contact can be defined, the default setting is On UPS.	16	PE	Shielding to PE
17	Com1		18	CAN+	CAN bus (reserved), set the matching resistor to PIN2 of SW1.
19	NC		20	CAN-	

NOTE: The BCB drive signal and external battery temperature signal must be carried through shielded cables, and both sides of the shielding coat must be securely connected to the enclosure.

The list of definable input dry contact described in **Table 4.8** below.

Table 4.8 Input Dry Contact Functions

Number	Function Description	Number	Function Description
1	External switch status (optional mains input/bypass input/external output/external maintenance bypass/load switch)	10	BCB tripping required
2	Turn off the inverter	11	Charger off
3	BCB enabled (8-group settable)	12	Start battery manual test
4	BCB feedback status (8-group settable)	13	Stop battery manual test
5	Fault clear	14	Generator mode
6	Battery system abnormal	15	ECO mode paused
7	Battery system fault	16	Battery grounding fault (8-group settable)
8	Battery low voltage	17	BCB power abnormal
9	Battery room over temperature		

The list of definable output dry contact functions is described in **Table 4.9** below.

Table 4.9 Output Dry Contact Functions

Number	Function Description	Number	Function Description
1	UPS alarm	6	On maintenance bypass
2	UPS fault	7	Input voltage abnormal
3	On inverter	8	Battery low voltage
4	On battery	9	BCB trip
5	On bypass		

The schematic diagram of dry contact port J22 is shown in **Figure 4.9** below and described in **Table 4.10** below. The dry contact voltage/current is 24 VDC/250 VAC, and the current is 5 A.

Figure 4.9 Dry Contact Port J22

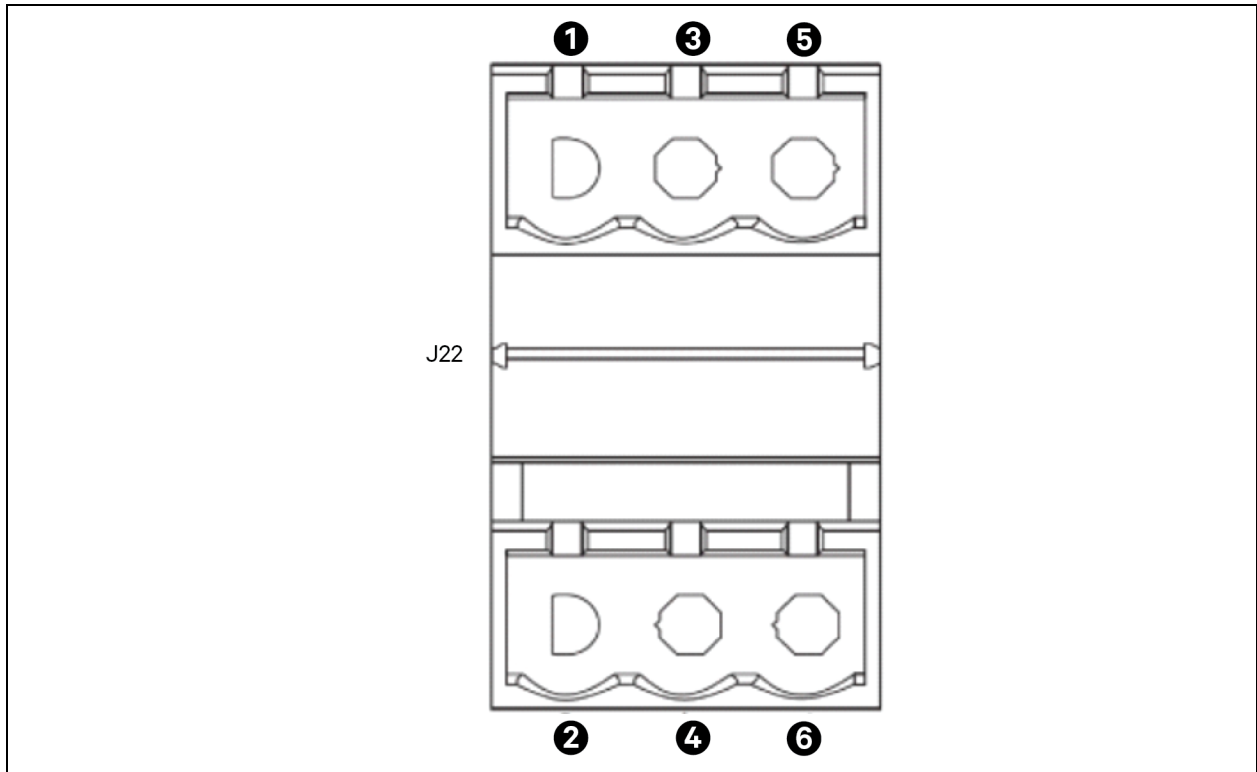

Table 4.10 Description of Dry Contact Port J22

Port	Pin	Name	Description
Bypass backfeed	J22-1	BFP_O	Normally open. Closed when bypass has backfeed.
	J22-3	BFP_S	Bypass backfeed protection relay common.
	J22-5	BFP_C	Normally closed. Open when bypass has backfeed.
Bypass backfeed drive power	J22-2	NA	NA
	J22-4	Dry_relay_o	24 V Bypass backfeed drive power (options should be configured).
	J22-6	GND	24 V Power ground.

4.2.3 Input/Output Dry Contact Port X7 J1

The schematic diagram of output dry contact port J1 is shown in **Figure 4.10** below and described in **Table 4.11** below. The input dry contacts of this series provide 24 VDC/10 mA signals. The BCB drive signal can provide 12 VDC/10 mA signal.

Figure 4.10 Dry Contact Port J1

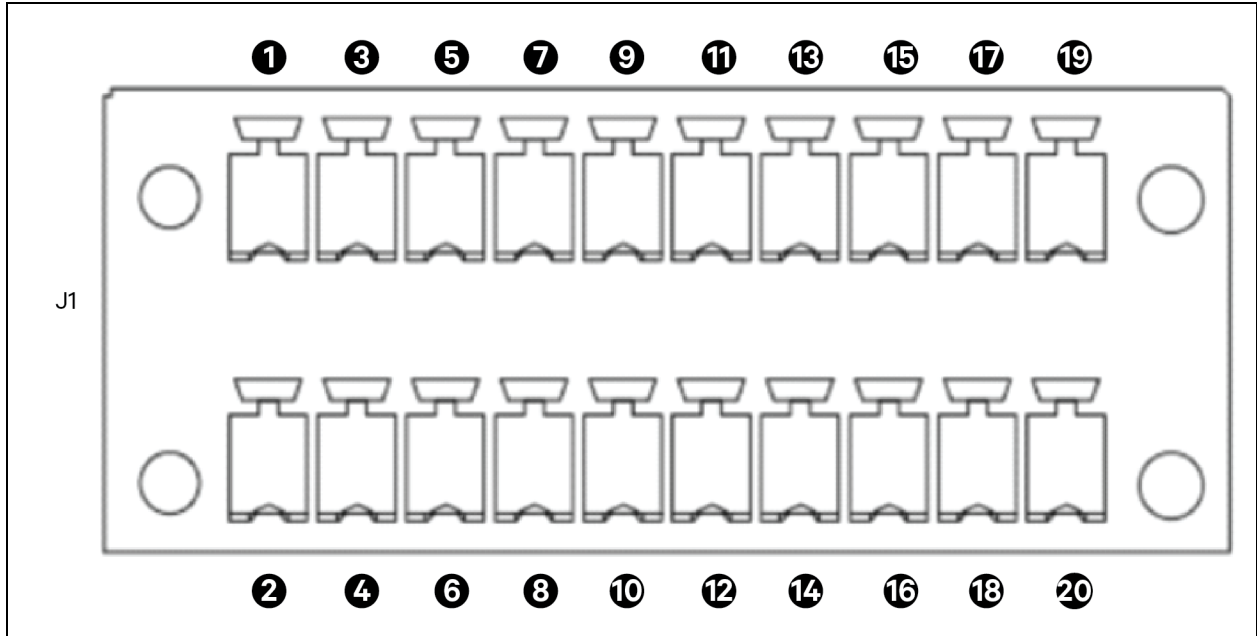

Table 4.11 Description of Dry Contact Port J1

Pin	Name	Meanings	Pin	Name	Meanings
1	GND	12 V Drive for BCB, or reserved for BIB and PSU kit, the default setting is BCB2&6&10 drive.	2	GND	12 V Drive for BCB, or reserved for BIB and PSU kit, the default setting is BCB3&7&11 drive.
3	BCB Drive 2		4	BCB Drive 3	
5	Dry in	Input dry contact can be defined, the default setting is BCB2 status feedback, NO contact.	6	Dry in	Input dry contact can be defined, the default setting is BCB3 status feedback, NO contact.
7	GND		8	GND	
9	Dry in	The input dry contact can be defined, and the default setting is BCB2 online, NO contact.	10	Dry in	The input dry contact can be defined, and the default setting is BCB3 online, NO contact.
11	GND		12	GND	
13	Dry in	The input dry contact can be defined, and the default setting is to turn off the inverter, NO contact.	14	Dry in	The input dry contact can be defined, and the default setting is the state of the external output switch MOB/QE, NO contact.
15	GND		16	GND	
17	Dry in	The input dry contact can be defined, and the default setting is the maintenance switch MBB/QBP state, NO contact.	18	Dry in	The input dry contact can be defined, and the default setting is the state of external maintenance isolation switch, NO contact.
19	GND		20	GND	

NOTE: The programmable dry contacts must be set in Paramset.

When using a parallel system, if you want to use the dry contact function of the external maintenance isolation circuit breaker, the auxiliary contact signal must be connected to the respective dry contacts on all single racks in the parallel system at the same time.

4.2.4 Input/Output Dry Contact Port X7 J2

The schematic diagram of the output dry contact port J2 is shown in **Figure 4.11** below and described in **Table 4.12** below. The input dry contacts of this series provide 24 VDC/10 mA signals, and the output dry contacts are relay contacts that can accept 24 VDC/1 A or 125 VAC/500 mA signals. The BCB drive signal can provide 12 VDC/10 mA signal.

Figure 4.11 Dry Contact Port J2

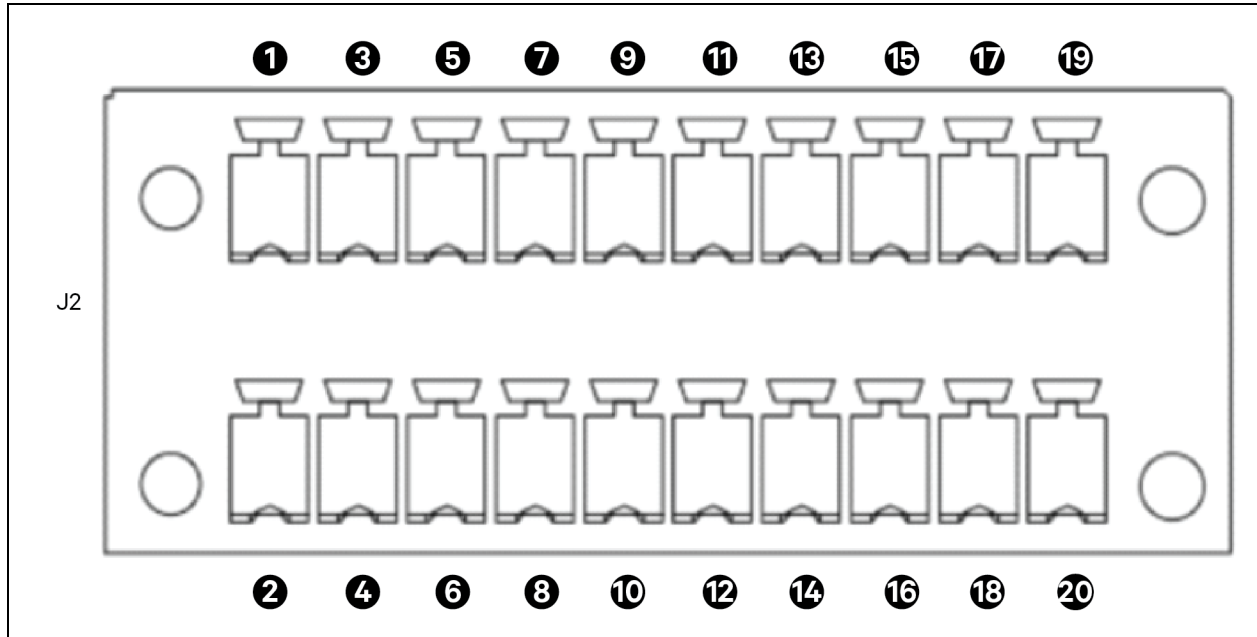

Table 4.12 Description of Dry Contact Port J2

Pin	Name	Meanings	Pin	Name	Meanings
1	Dry in	The input dry contact can be defined, and the default setting is the load test switch LLBB state, NO contact.	2	GND	12 V Drive for BCB, or reserved for BIB & PSU kit, the default setting is BCB4&8&12 drive.
3	GND		4	BCB Drive 4	
5	Dry in	The input dry contact can be defined, and the default setting is the state of the main input switch RFB/Q1, NO contact.	6	Dry in	The input dry contact can be defined, and the default setting is BCB4 status feedback, NO contact.
7	GND		8	GND	
9	NO	The output dry contact can be defined, and the default setting is On bypass.	10	Dry in	The input dry contact can be defined, and the default setting is the state of the bypass input switch RBB/Q2, NC contact.
11	COM		12	GND	
13	NC		14	Dry in	
15	NO	The output dry contact can be defined, and the default setting is On battery.	16	GND	NA
17	COM		18	NA	
19	NC		20	GND	

NOTE: The programmable dry contacts must be set in Paramset.

When using parallel system, if you want to use the dry contact function of the external maintenance isolation circuit breaker, the auxiliary contact signal must be connected to the respective dry contacts on all single racks in the parallel system at the same time.

4.2.5 Input/Output Dry Contact Port X7 J3

The schematic diagram of output dry contact interface J3 is shown in **Figure 4.12** below and described in **Table 4.13** below. The dry contact voltage/current rating is 24 VDC/250 VAC, and the current is 5 A.

Figure 4.12 Dry Contact Port J3

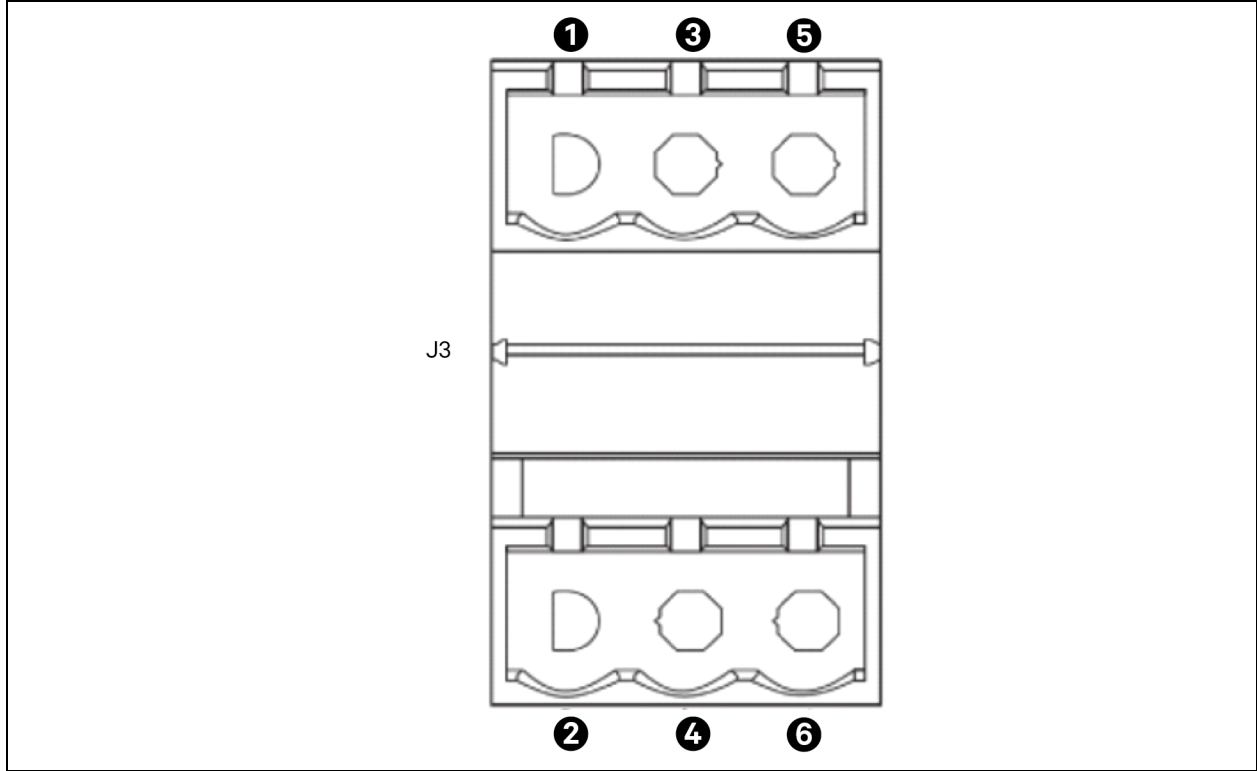

Table 4.13 Description of Dry Contact Port J3

Port	Pin	Name	Default Signal
MBB and MIB interlock signal	J3-1	NO	Normally open. External maintenance bypass MBB and system inverter main switch MIB interlock signal.
	J3-3	COM	Common contact
	J3-5	NC	Normally closed
Input backfeed	J3-2	NO	Normally open. Closed when bypass has backfeed.
	J3-4	COM	Common contact
	J3-6	NC	Normally closed. Open when input has backfeed.
NOTE: X7 J3 pins are programmable contacts.			

4.2.6 Remote Emergency Power Off Port

The UPS consist of a (REPO) function that operates by either an REPO button on the touchscreen of the UPS or a remote contact provided by the user. The REPO button has a protective cover.

Within 328.08 ft. (100 m) of the communication line, use a shielded wire, and both ends of the shielded wire are grounded. If the length exceeds 328.08 ft. (100 m), the shielded wire must go through a metal pipe.

The schematic diagram of the REPO port is shown in **Figure 4.13** below and described in **Table 4.14** below.

Figure 4.13 Remote Emergency Power Off Port

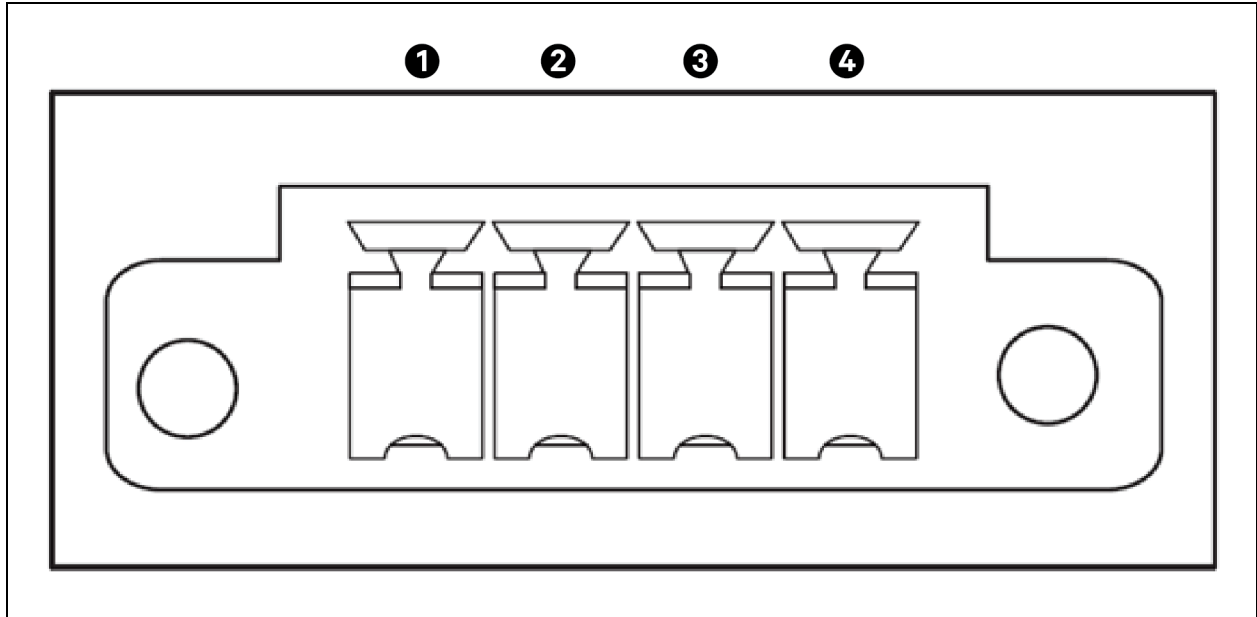

Table 4.14 Remote Emergency Power Off Port Pins

Pin	Name	Meanings
1	EPO-NC	REPO activated when opened to Pin 2.
2	+ 12 V	REPO activated when opened to Pin 1.
3	+ 12 V	REPO activated when shorted to Pin 4.
4	EPO-NO	REPO activated when shorted to Pin 3.

The REPO is triggered when the pins 3 and 4 are shorted or the pins 2 and 1 are opened.

If an external REPO function is required, pins 1 and 2 or 3 and 4 are reserved for this function. The external REPO facility is also connected to the normally open or normally closed REPO switch between these two terminals using shielded cable. If this function is not required, pins 3 and 4 must be opened and pins 1 and the 2 must be closed.

NOTE: The REPO action of the UPS shuts down the rectifier, the inverter, and the static bypass, but it does not internally disconnect the mains input power supply. To disconnect all power to the UPS, open the external power switch, bypass input switch, output switch and BCB after the REPO is activated.

4.2.7 Parallel and Load Bus Synchronization Communication Ports

See **Figure 4.7** on page 48 for the positions of the parallel and LBS communication port.

4.2.8 Vertiv™ Liebert® IntelliSlot™ Port

The Vertiv™ PowerUPS 9000 1250 kVA 415 V Modular UPS consist of two IntelliSlot ports which allows field installation of the optional communication cards, including Vertiv™ Liebert® IntelliSlot™ IS-UNITY-DP card, and Vertiv™ Liebert® IntelliSlot™ IS-Relay card. **Table 4.15** below describes the models and installation positions of the optional cards. For the detailed installation of the optional cards, see the respective contents in the [Vertiv™ PowerUPS 9000 1250 kVA 415 V Modular UPS Option Configurations](#) on page 113.

Table 4.15 Models and Installation Positions of Optional Cards

Optional Card	Model	Installation Position
Vertiv™ Liebert® IntelliSlot™ IS-RELAY card	IS-RELAY	Ports 1 to 2
Vertiv™ Liebert® IntelliSlot™ RDU120 card	RDU120	Ports 1 to 2

NOTE: When using the Vertiv Liebert IntelliSlot RDU120 Card, it is necessary to set the IS RS-485 Bus protocol to Velocity on the human machine interface (HMI).

NOTE: The Vertiv Liebert IntelliSlot RDU120 Card can be inserted in either ports 1 or 2, or both. If you use the card simultaneously, you need to reset the node code of the second card. When using, it is necessary to set the protocol of the IS RS-485 bus to velocity.

4.2.9 Signal Cable Connection Steps

Top cable access and bottom cable access are available for 1250 kVA UPS. See **Figure 4.14** on the facing page and **Figure 4.15** on page 58 for the cabling route and then connect signal cables to corresponding ports shown in **Figure 4.7** on page 48.



WARNING! Risk of electric shock. Can cause equipment damage, personnel injury, or death. Verify that all external and internal power switches of the UPS are turned off and locked out or tagged out before installing the cables or making any electrical connections. Also, measure the voltages between the UPS terminals and the voltages between the terminals and the earth.



AVERTISSEMENT! Risque de choc électrique. Peut provoquer des dommages à l'équipement, des blessures au personnel ou la mort. Vérifiez que tous les interrupteurs d'alimentation externes et internes de l'onduleur sont éteints et verrouillés ou étiquetés avant d'installer les câbles ou de faire des connexions électriques. Mesurez également les tensions entre les bornes de l'onduleur et les tensions entre les bornes et la terre.

NOTE: The power cables and signal cables should be routed respectively. The shielding coat of signal cable must be reliably earthed.

Figure 4.14 Signal Cables Wiring Route of 1250 kVA (Top Cable Access)

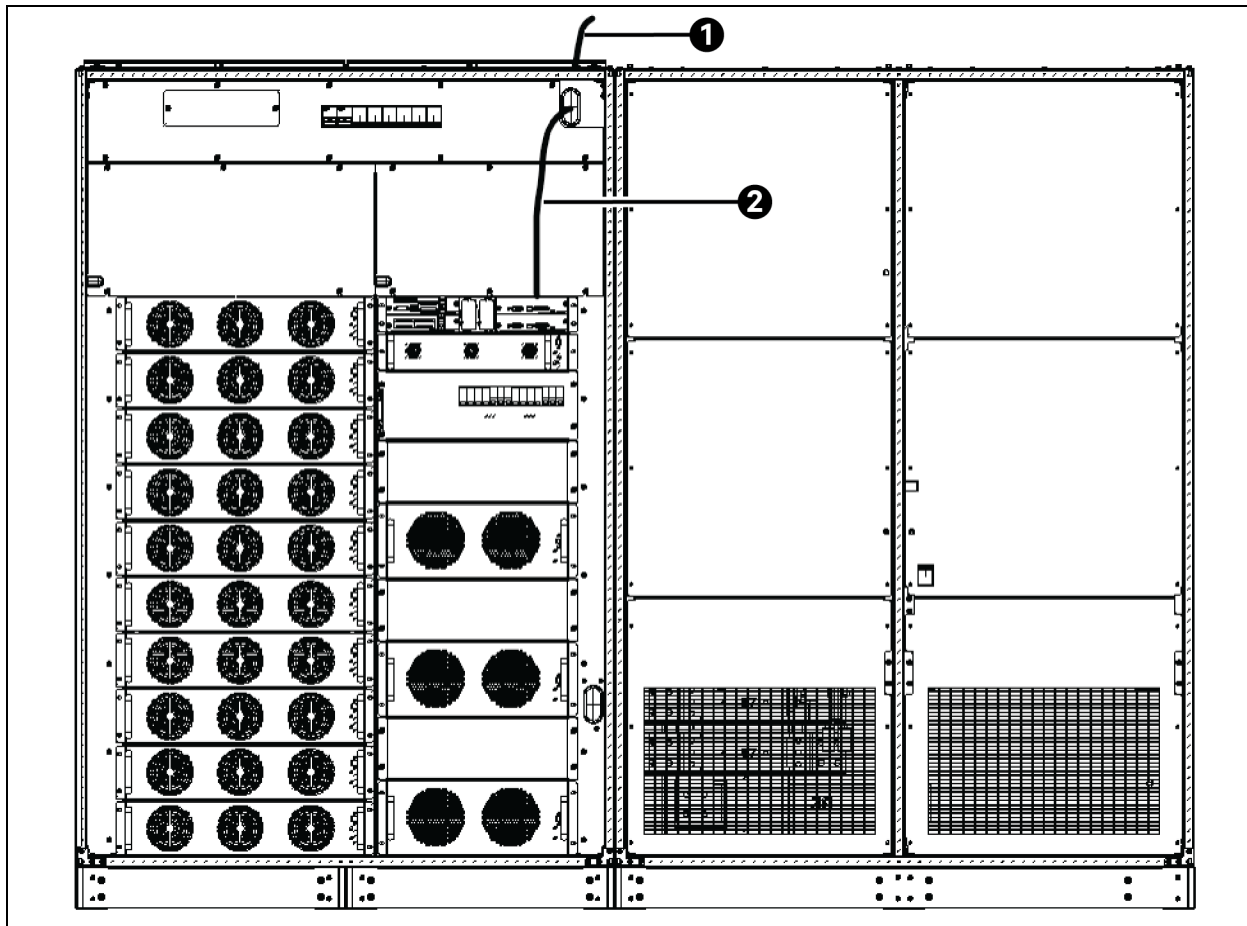

Item	Description
1	Lead the signal cables into the cabinet through this cabling entry plate.
2	Connect them to corresponding terminals.

Figure 4.15 Signal Cables Wiring Route of 1250 KVA (Bottom Cable Access)

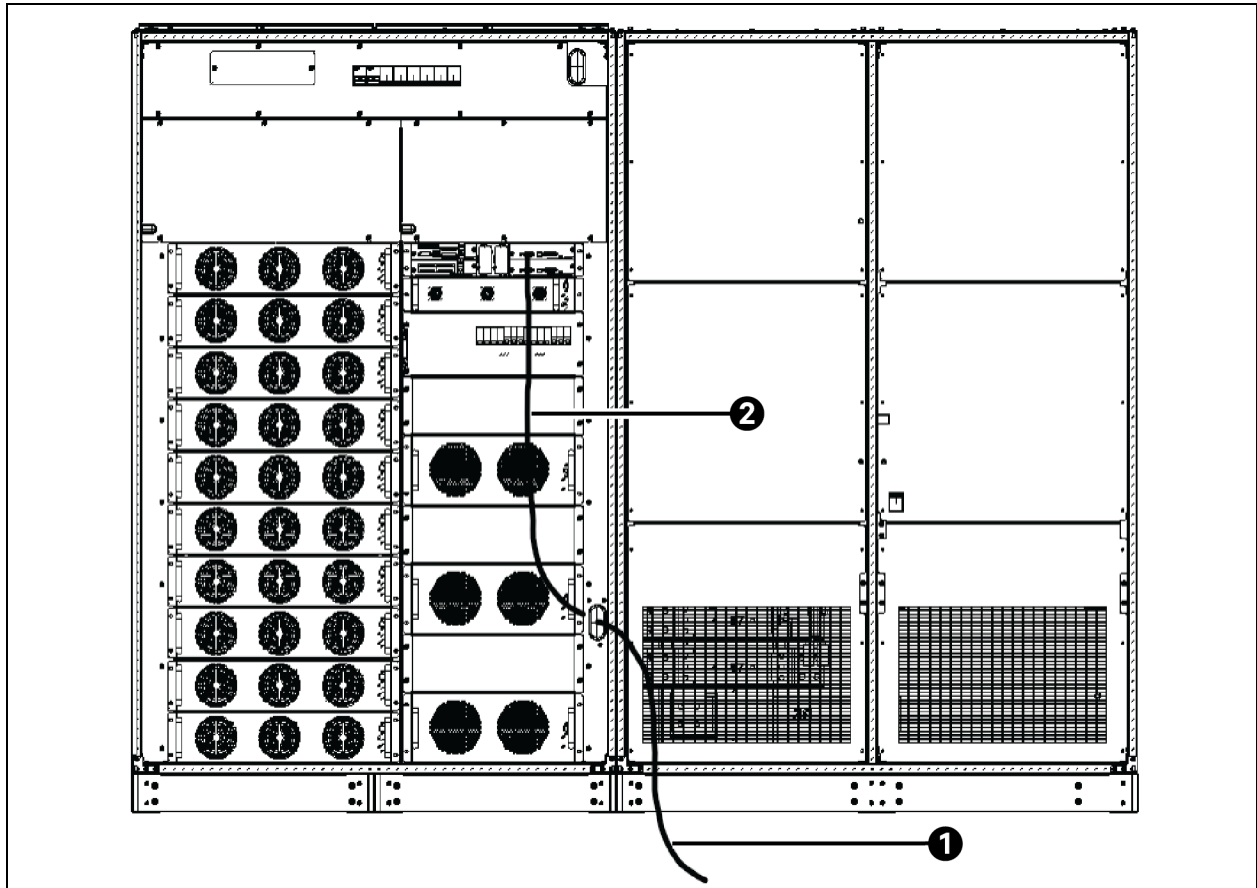

Item	Description
1	Lead the signal cables into the cabinet through this cabling entry plate.
2	Connect to corresponding terminals.

5 Operator Control and Display Panel

5.1 Introduction

The integrated display of touchscreen control panel of the UPS simplifies monitoring and managing single or multiple Vertiv™ Liebert® UPS modules. The control collects information about the health of the modules and presents it in a standardized format. This simple, dynamic display speeds operator response to changing power input and demand.

Most of the settings depend on the UPS type and features. Other settings will be made during the UPS setup by Vertiv service personnel. The Vertiv™ PowerUPS 9000 1250 kVA 415 V Modular UPS touchscreen control panel display shows data either graphically or as text. The status scroll bar at the top of the touchscreen shows the system conditions. The bar changes color to indicate status and includes an icon matched to the status. The Status Gauge displays details as power demand from the connected load, input power quality, output and bypass on each phase and battery capacity.

5.2 Navigating through the Vertiv™ PowerUPS 9000 1250 kVA 415 V Modular UPS Touchscreen

The Vertiv PowerUPS 9000 1250 kVA 415 V Modular UPS touchscreen control panel is active when the UPS has input power. The touchscreen on the front of the UPS permits:

- Login Capability. See [Login](#) on page 61 for more information.
- Silencing alarms. See [Silence an Alarm](#) on page 64 for more information.
- Turning the UPS On. See [Inverter On](#) on page 64 for more information.
- Turning the UPS Off. See [Inverter Off](#) on page 65 for more information.
- Resetting faults. See [Reset Fault](#) on page 66 for more information.
- Enabling energy saving mode. See [Energy Saving Mode Activation](#) on page 66 for more information.

To check the status of the UPS and its external batteries, including all measured parameters, events, and alarms, see [Viewing UPS Status](#) on page 68 and viewing UPS component status.

The Vertiv PowerUPS 9000 1250 kVA 415 V Modular UPS touchscreen control panel's display default view is two panes. One line graphic screen and unit status. The appearance can be changed to multiple panes that show other data. Customizing the appearance is detailed in customizing the display.



CAUTION: Risk of unauthorized changes to operational settings. Can cause equipment damage. The default PIN numbers should be changed immediately to prevent unauthorized personnel from changing UPS operation or even shutting down the UPS. The PINs for Operator and Administrator may be changed by logging in with either Administrator or Service level access.

5.2.1 Vertiv™ PowerUPS 9000 1250 kVA 415 V Modular UPS Touchscreen Control Panel Components

The main areas of the Vertiv PowerUPS 9000 1250 kVA 415 V Modular UPS touchscreen control panel are shown in **Figure 5.1** below and **Figure 5.2** on the facing page. The display arrangement and the information displayed can be changed. At login for all access levels, the Vertiv PowerUPS 9000 1250 kVA 415 V Modular UPS touchscreen control panel opens to the Status screen in graphic display. The Status screen will show the graphic screen and system status readings at each login level. The appearance will differ only in the function menus displayed, as shown in **Figure 5.3** on page 62.

Figure 5.1 Touchscreen Control Panel Components

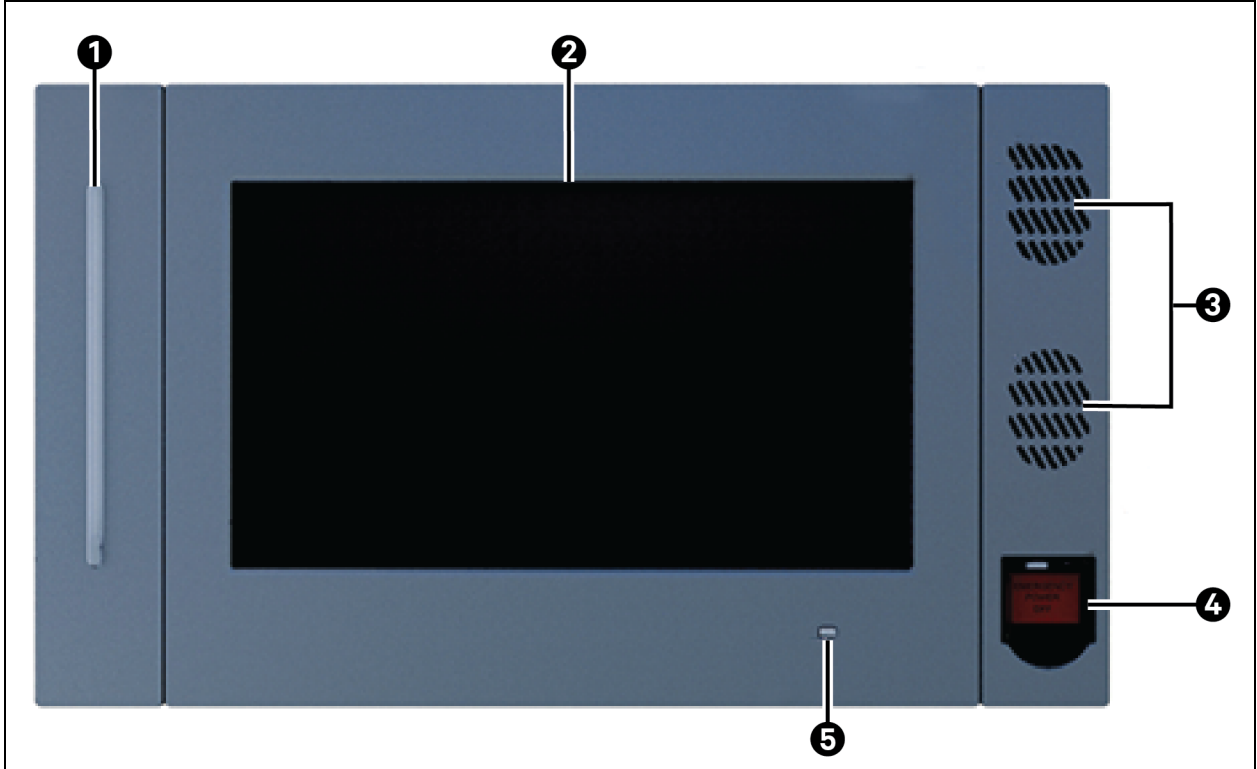

Item	Description	Item	Description
1	UPS Status LED	4	Remote EPO Switch
2	Touchscreen LCD	5	UPS Status LED
3	Speakers (not used)		

Figure 5.2 Interface Overview—Status Screen Graphic Display

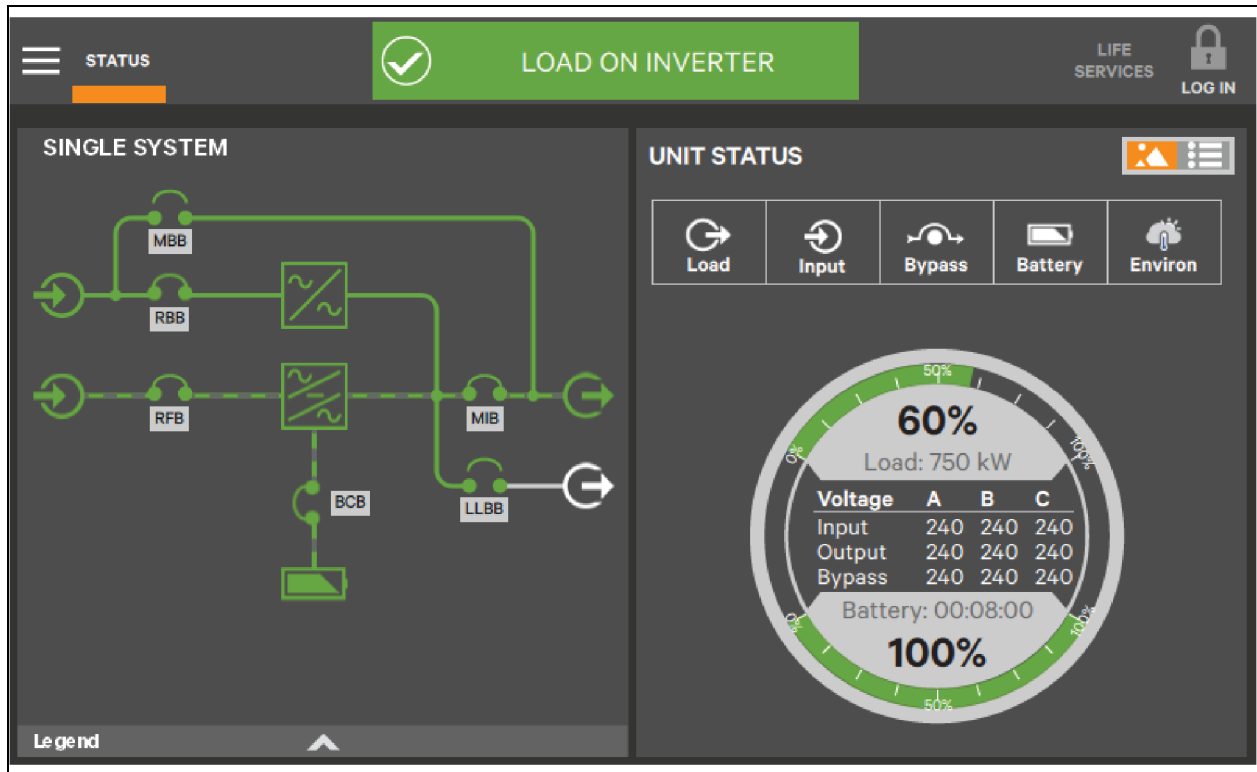

Information and control are different under each Function Menu. The Function Menus displayed are specific to the access level.

- **Status:** Condition of the UPS components and data affecting operation and performance. Visible to all access levels.
- **Operate:** UPS operation controls, such as inverter on, inverter off, energy saving status. Visible to Operator, Administrator and Service.
- **Setup:** Manage permissions through PINs. Visible to Administrator and Service.
- **Service:** Input wiring and breaker configuration, protocol used. Visible to Service.

5.3 Operation

5.3.1 Login

The Vertiv™ PowerUPS 9000 1250 kVA 415 V Modular UPS touchscreen control panel provides security by limiting the authority to change how the UPS operates. The 4 access levels offer different authority:

- **Observer:** Viewing permission only; can choose graphic or text display. No PIN is required.
- **Operator:** Permission to start the UPS, shut down the system, reset faults and enable or disable ECO Mode operation. PIN is required.
- **Administrator:** All functions of Operator plus permission to change PINs for Operator and Administrator level. PIN is required.
- **Service:** All functions of Administrator plus permission to alter system configuration, choose serial communication protocol, enable equalize battery charging and change Service PIN. PIN is required.

Vertiv™ Liebert® Tech Services provide PINs when setting up the UPS. These default PINs may be changed by those with Administrator or Service access.

NOTE: The default Operator PIN is 1234.

! CAUTION: Risk of unauthorized changes to operational settings. Can cause equipment damage. The default PIN numbers should be changed immediately to prevent unauthorized personnel from changing UPS operation or even shutting down the UPS. The PINs for Operator and Administrator may be changed by logging in with either Administrator or Service level access.

The Vertiv™ PowerUPS 9000 1250 kVA 415 V Modular UPS touchscreen control panel is on when the UPS has control power. It is inactive and appears dark, depending on its settings. Touch the touchscreen to turn it on.

To log in to the Vertiv PowerUPS 9000 1250 kVA 415 V Modular UPS touchscreen control panel:

1. Touch the Log In icon at the top right of the screen. The lock and background change color a prompt, PIN required screen, is displayed.
2. Enter a PIN at the prompt using the keypad on the touchscreen.
3. Touch Enter.

NOTE: If you enter an incorrect PIN, a prompt stating the PIN is invalid is displayed.

Figure 5.3 Log In Screen

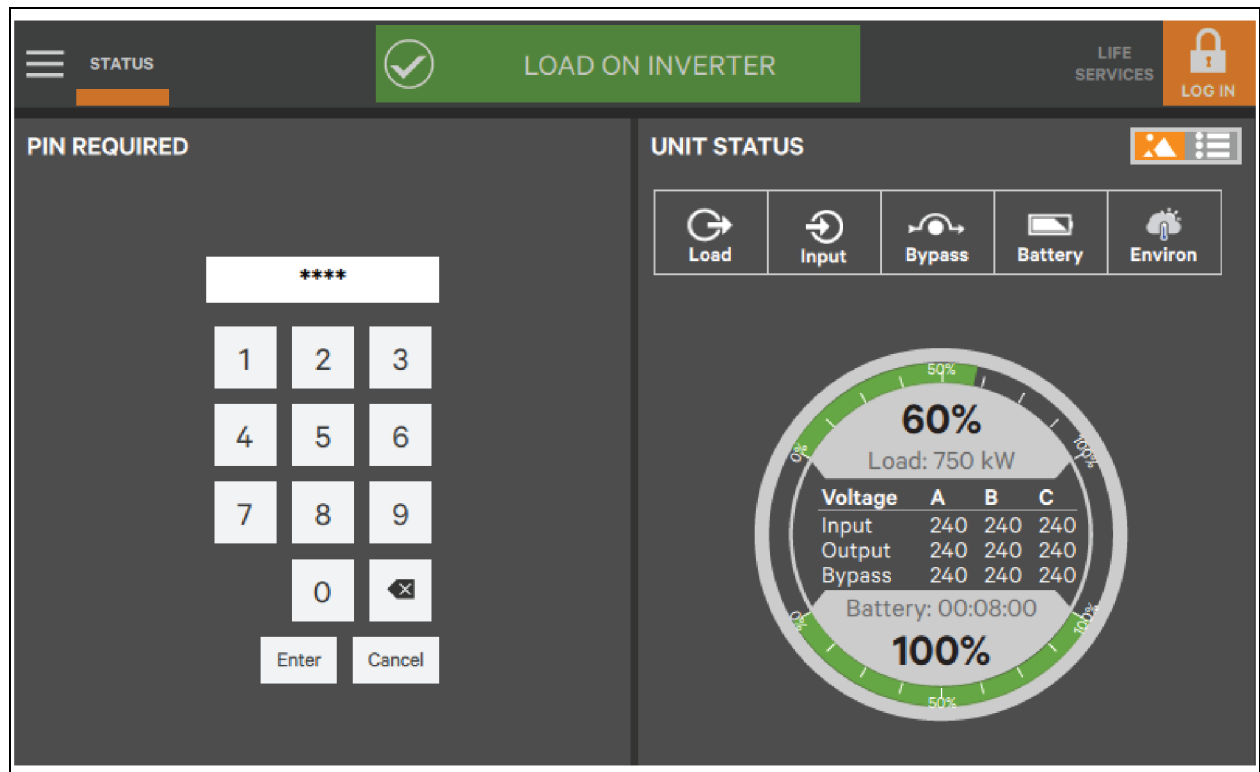

5.3.2 Operator Controls

The Operator login enables control of UPS functions:

- Silence (Alarm)
- Inverter On
- Inverter Off
- Reset Fault
- Energy Saving Mode Activation

Each command is available under the Operate menu. The Operate menu may be used by logging in with Operator, Administrator, and Service access.

Operate Menu Commands

All Operator commands are available from the Operate menu. The menu is available when the UPS has input power. The UPS need not be supplying power to the load for the menu to be available. The graphic screen is not linked to data in this view—touching a component will not cause it to display data.

Figure 5.4 Operate Menu

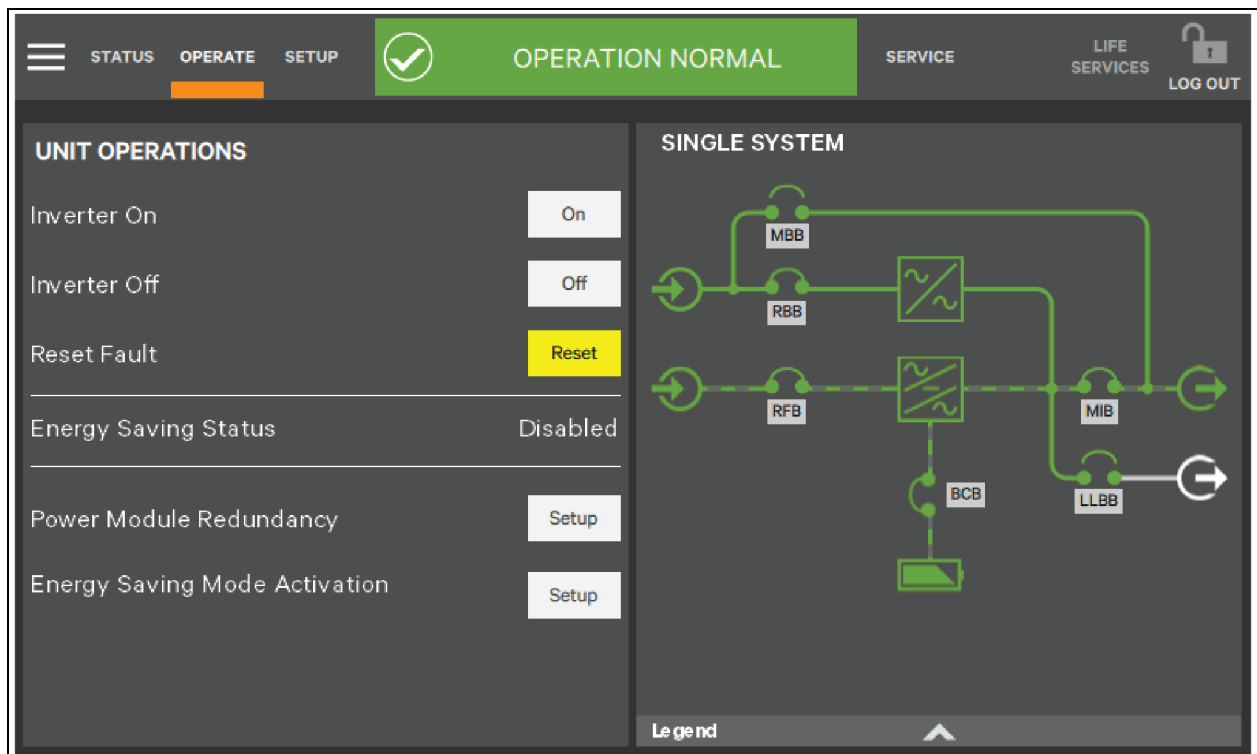

CAUTION: Risk of improper operation. Can cause load drop resulting in equipment damage. The Inverter On, Inverter Off, Reset Fault, and Energy Saving Mode Activation commands will be available whenever the UPS is operating. Before executing any command, verify that the UPS status is suitable for the command to be performed.

Silence an Alarm

To silence an alarm, touch the Silence button at the top of the panel. The time the alarm will remain silenced varies, depending on the UPS type, type of alarm, and configuration.

Inverter On

The Inverter On menu item is available when the UPS has input power, and the inverter is off. Before executing the command, verify that the UPS is prepared for the inverter to start. When the operator access is shown, commands are the same for all access levels. The Vertiv™ PowerUPS 9000 1250 kVA 415 V Modular UPS touchscreen control panel displays a message asking for confirmation. Touch On to confirm, see **Figure 5.5** below. The control then displays a progress window while the inverter starts.

Figure 5.5 Inverter On Screen

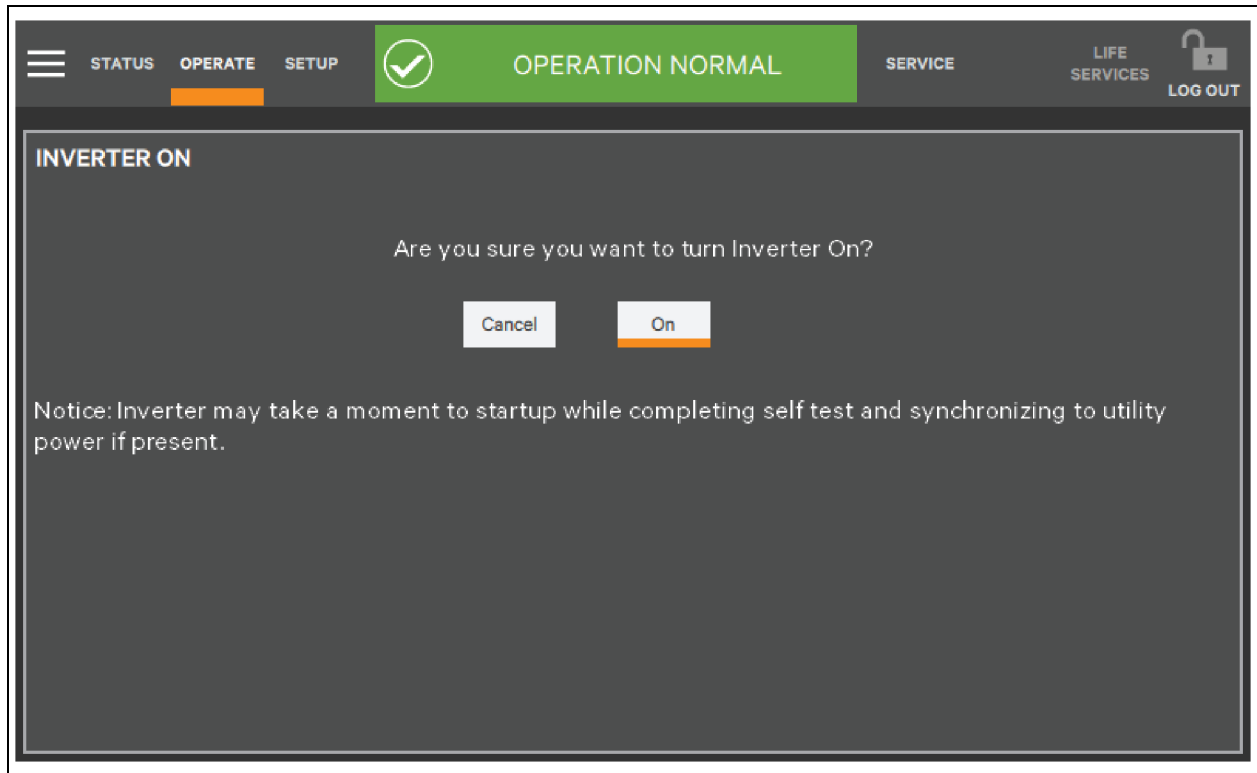

Inverter Off

The Inverter Off menu item is available whenever the UPS has input power and the inverter is on. Before executing the command, verify that the UPS and connected load are prepared for the inverter to be shutdown. Touch Off to turn the inverter Off.



CAUTION: Risk of improper operation. Can cause load drop resulting in equipment damage. The Inverter Off will shut off power to the connected load unless bypass power is available. Before executing this command, verify that the connected load is either shut off or that input power to the load will be supplied by another source, such as bypass.

Figure 5.6 Inverter Off Screen

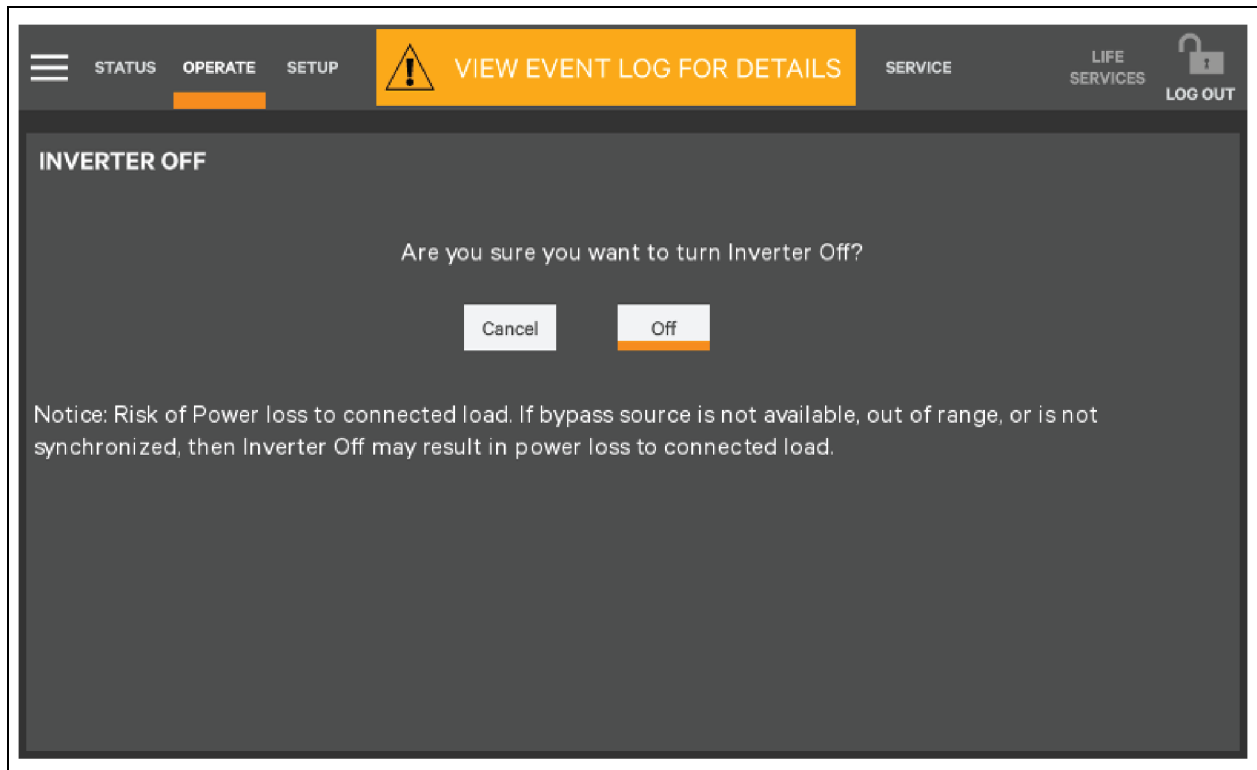

Reset Fault

Reset faults by touching the Reset button.

Figure 5.7 Reset Fault Screen

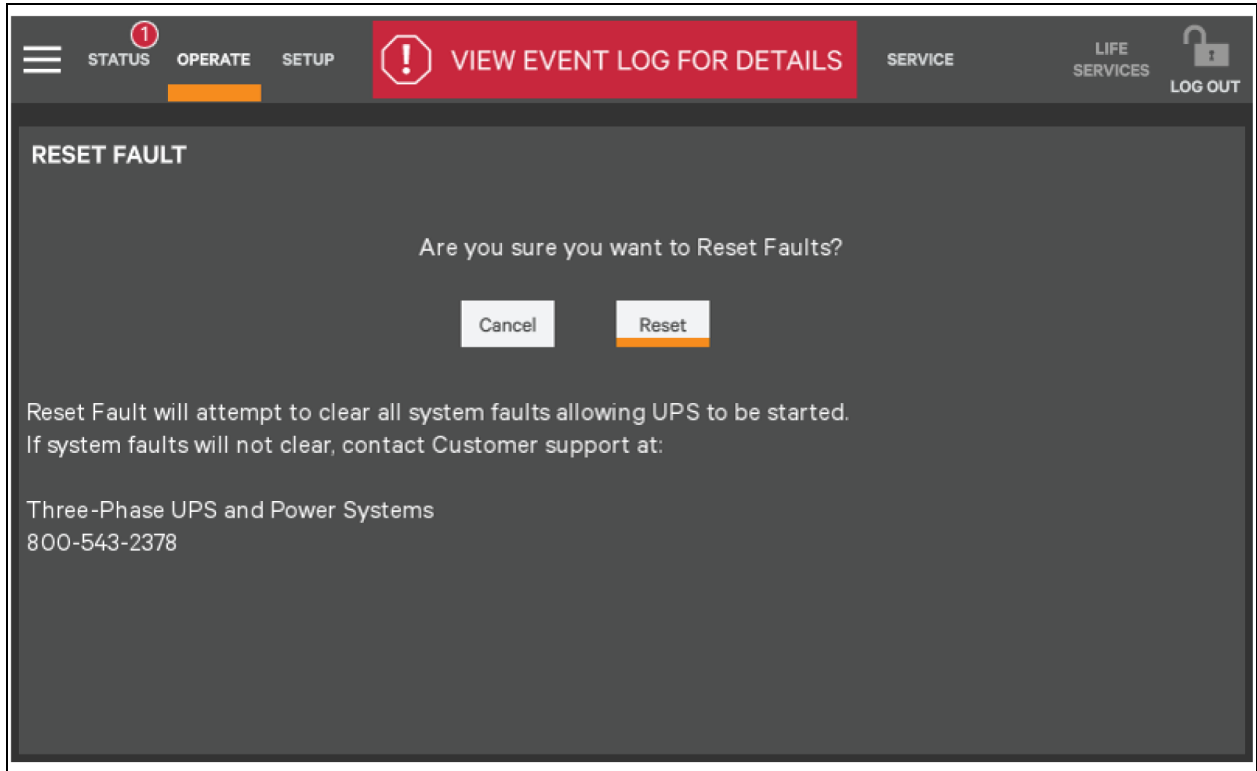

Energy Saving Mode Activation

NOTE: Read this manual carefully before activating Energy Saving Mode. Only an Operator can enable or disable Energy Saving Mode. The available modes vary according to the UPS type and system configuration. The types available must be set up by either Administrator or Service personnel.

Energy Saving Mode may be activated or deactivated through the Operate menu screen. Two modes are available as ECO mode and intelligent parallel mode.

ECO Mode permits the UPS to reduce power consumption by powering the load through bypass power when utility supplied power is within acceptable ranges. The inverter will remain in a state that will permit it to resume supplying power if the utility power goes outside acceptable ranges.

Intelligent paralleling puts units in sleep mode until required.

To activate or deactivate Energy Saving Mode:

1. Touch the Setup button for Energy Saving Mode Activation.
2. Enable or disable Energy Saving Mode.
3. Touch the Save button. The Save button is inactive until the activation state is changed.

Figure 5.8 Activating Energy Saving Mode

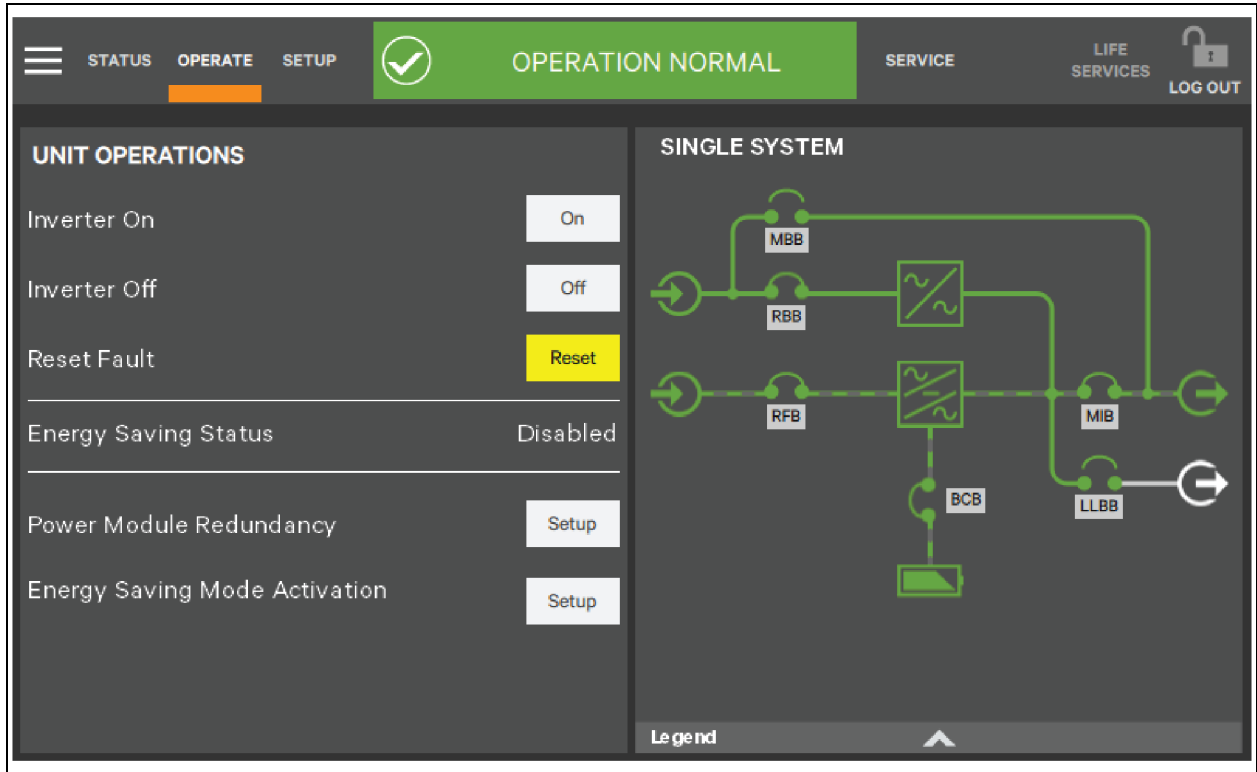
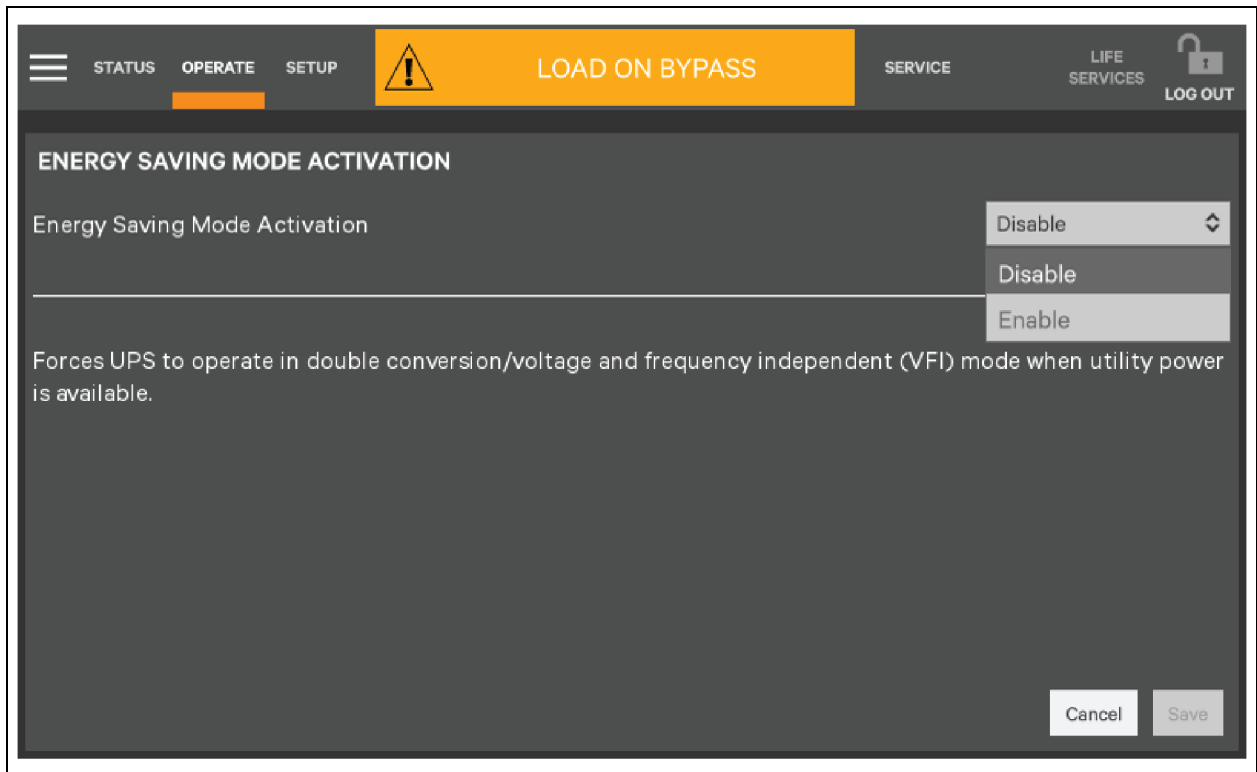

Figure 5.9 Energy Saving Mode Activation



5.4 Viewing UPS Status

The Vertiv™ PowerUPS 9000 1250 kVA 415 V Modular UPS touchscreen display reports UPS status in multiple ways. The graphic views and text views will show the same readings.

5.4.1 Status Bar Component

The status bar indicates UPS status by:

- Changing color. Color indicators are green for normal, yellow for warning, and red for alarm.
- Showing an icon inside the bar. See **Figure 5.10** below.

Figure 5.10 Status Bar Messages



Up to three messages may scroll through the status bar to the right of the status icon. Each message will have a duration of 4 seconds, except they change immediately if the system's status changes.

Alarms and certain events will trigger audible alarms and the LED on the bezel, the light bar and the status header will change color. (Audible alarms do not sound unless enabled.) For more information on how to enable the audible alarms, see **Figure 5.11** below. The scrolling information bar at the top of the interface summarizes information about the UPS status. The Status Gauge on the Unit Status pane gives additional details about the UPS status.

Figure 5.11 Audible Alarms Enable View

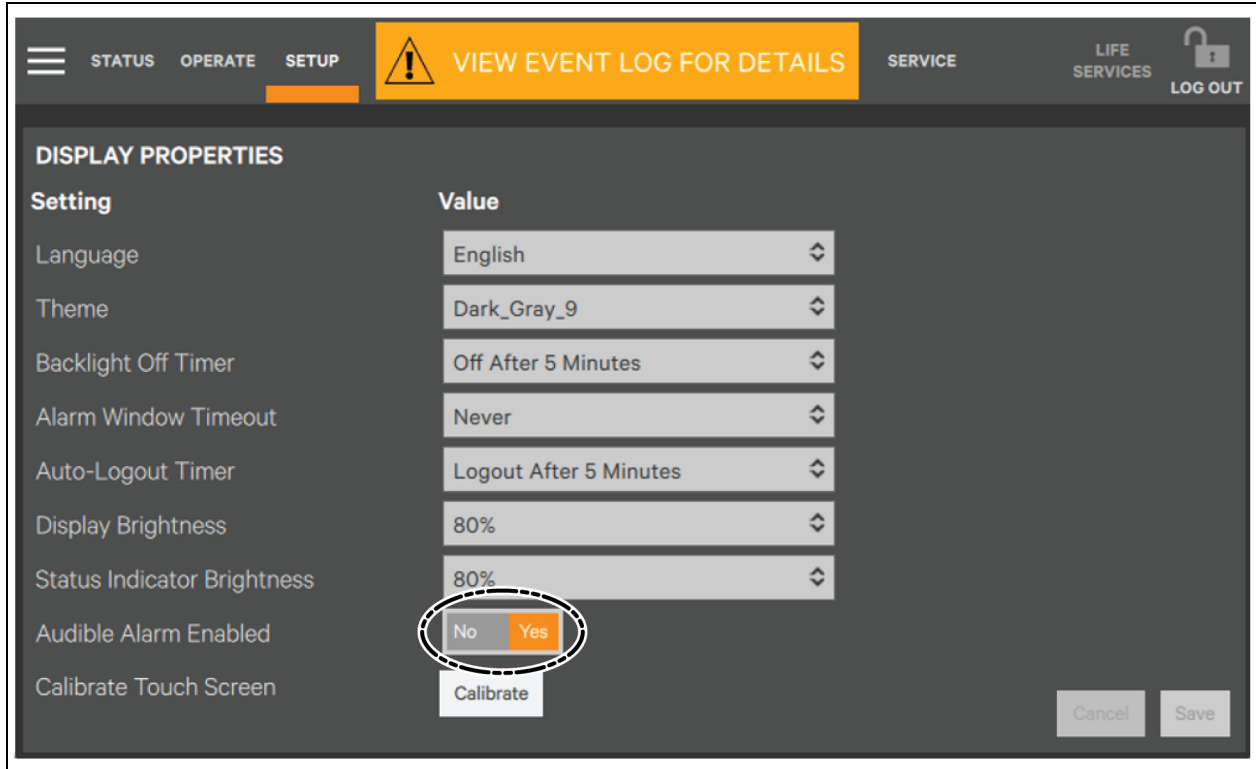

5.4.2 Viewing UPS Data with the Status Gauge

The Status Gauge offers a quick summary of the UPS status. The information shown depends on the type of UPS and its configuration and upon the choices made in the gauge setup. The data can be chosen by someone with Administrator or Service access.

The additional data will not replace the information shown in the center of the Status Gauge. Touching the center of the Status Gauge multiple times on will cycle through the data.

Figure 5.12 Default Status Gauge View

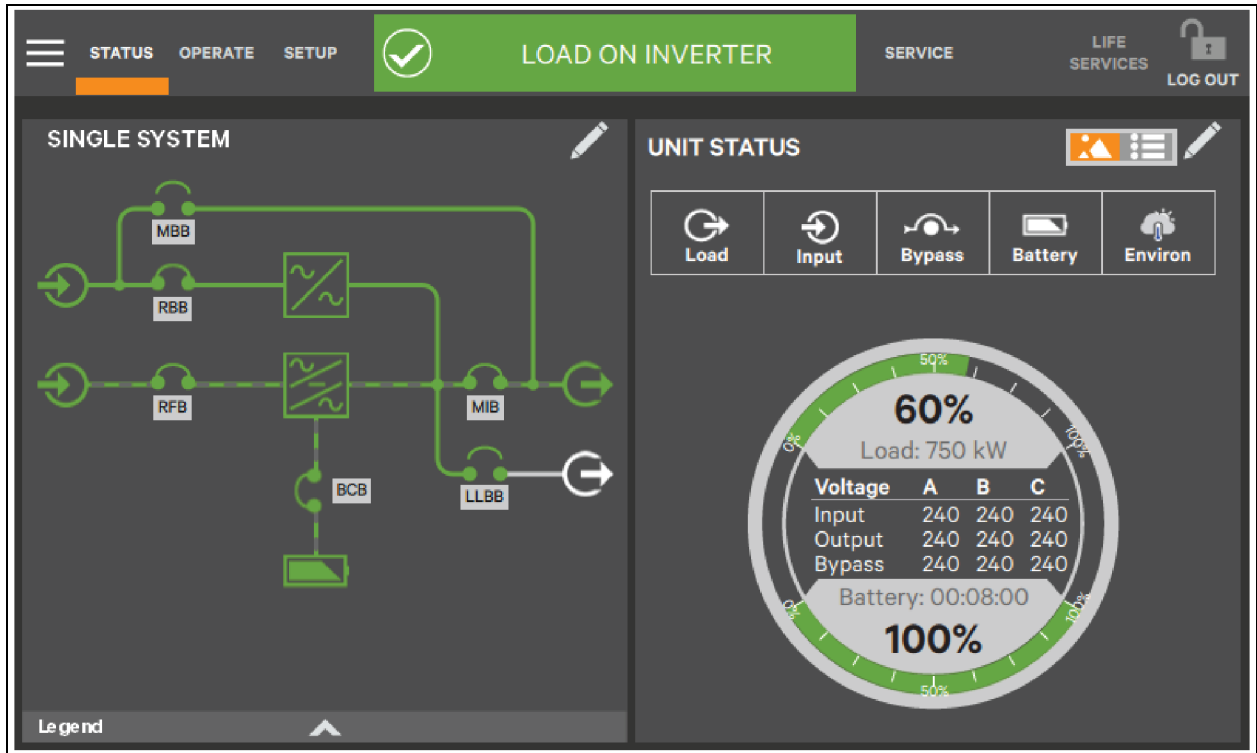

5.4.3 Viewing UPS Data with the Status Panel

More detailed information about the UPS status is readily available through the Status panel. Touching a component in the graphic screen display brings up data about the component on another pane. Touching a parameter icon on the Unit Status pane shows details about that parameter.

The same data can be viewed by switching to the text view. The length of the lists and order of the details may require scrolling to find the desired data.

NOTE: A parameter must be visible on the graphic view of the Unit Status screen for details to be viewed, even in the text view.

Figure 5.13 Unit Status—Input Details

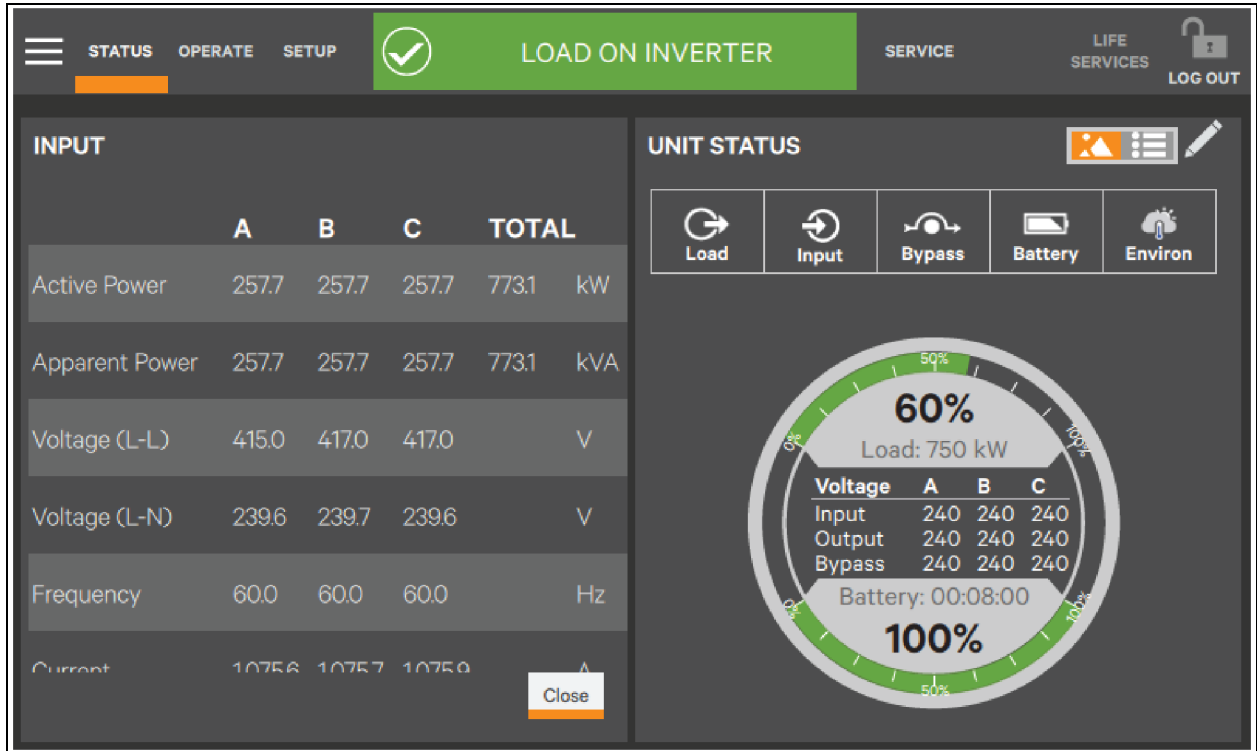

Figure 5.14 Unit Status—Bypass Details

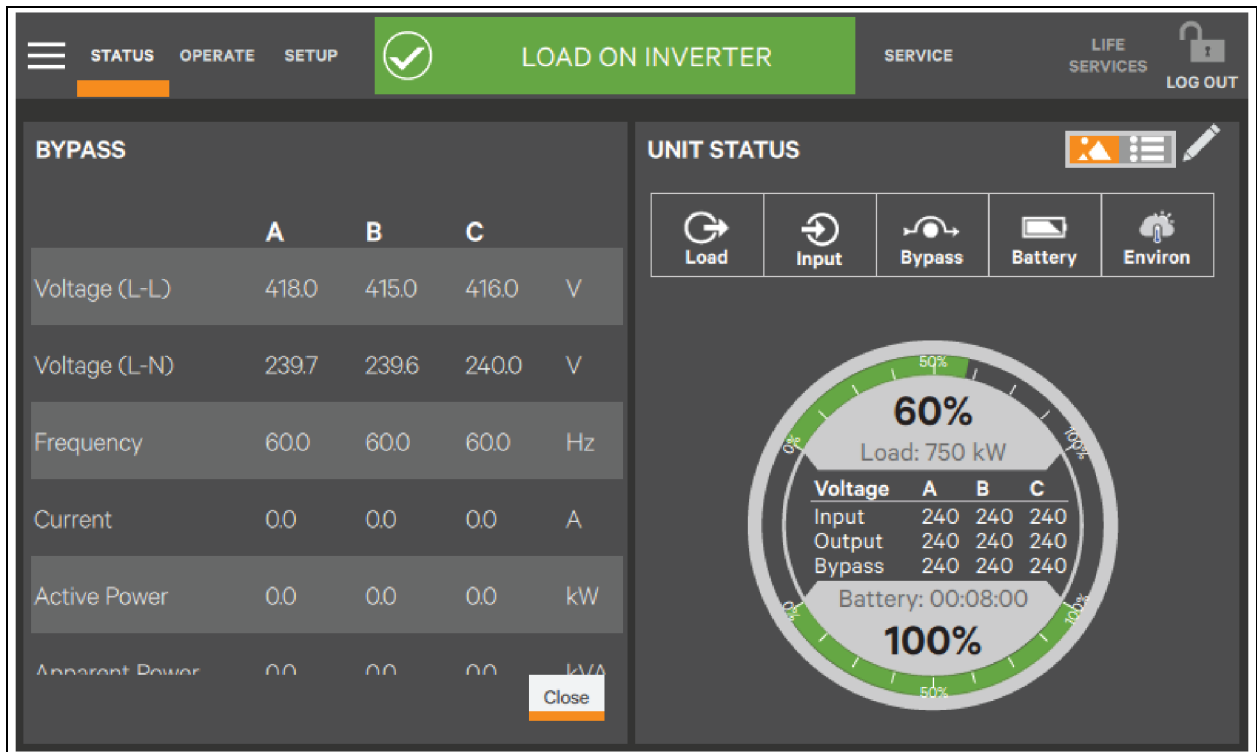

Figure 5.15 Unit Status—Battery Details

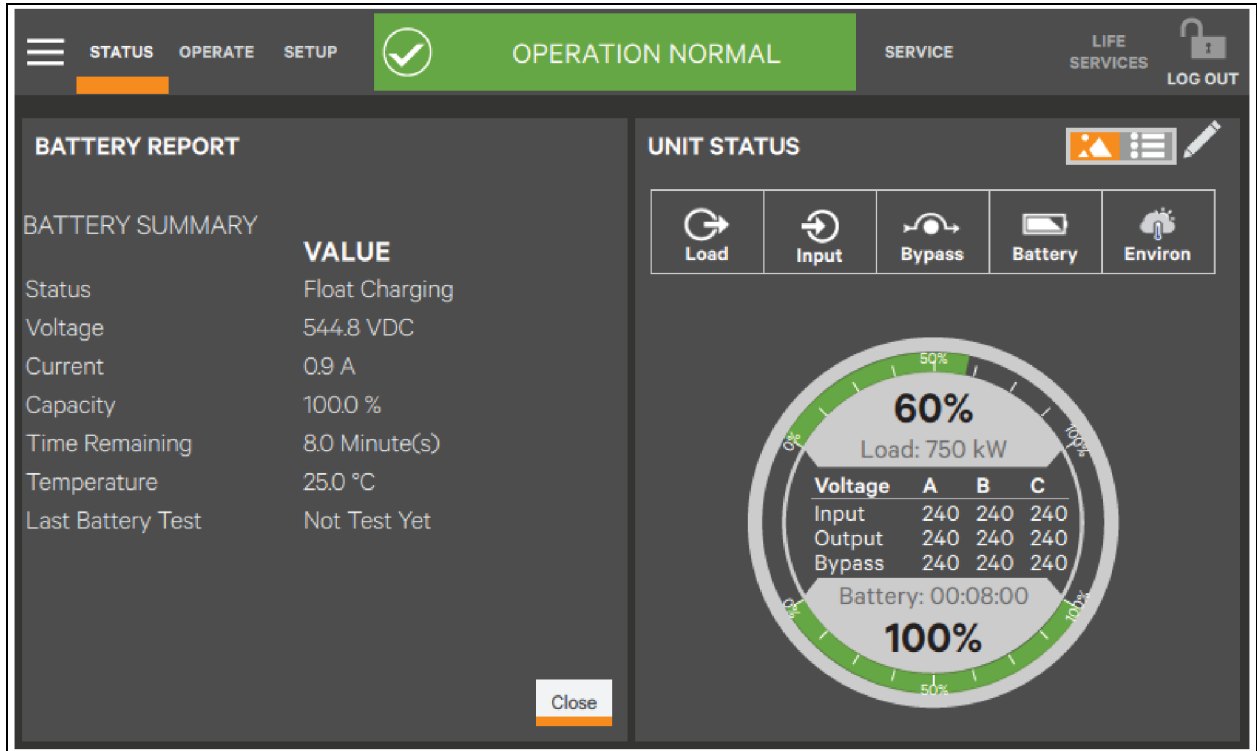
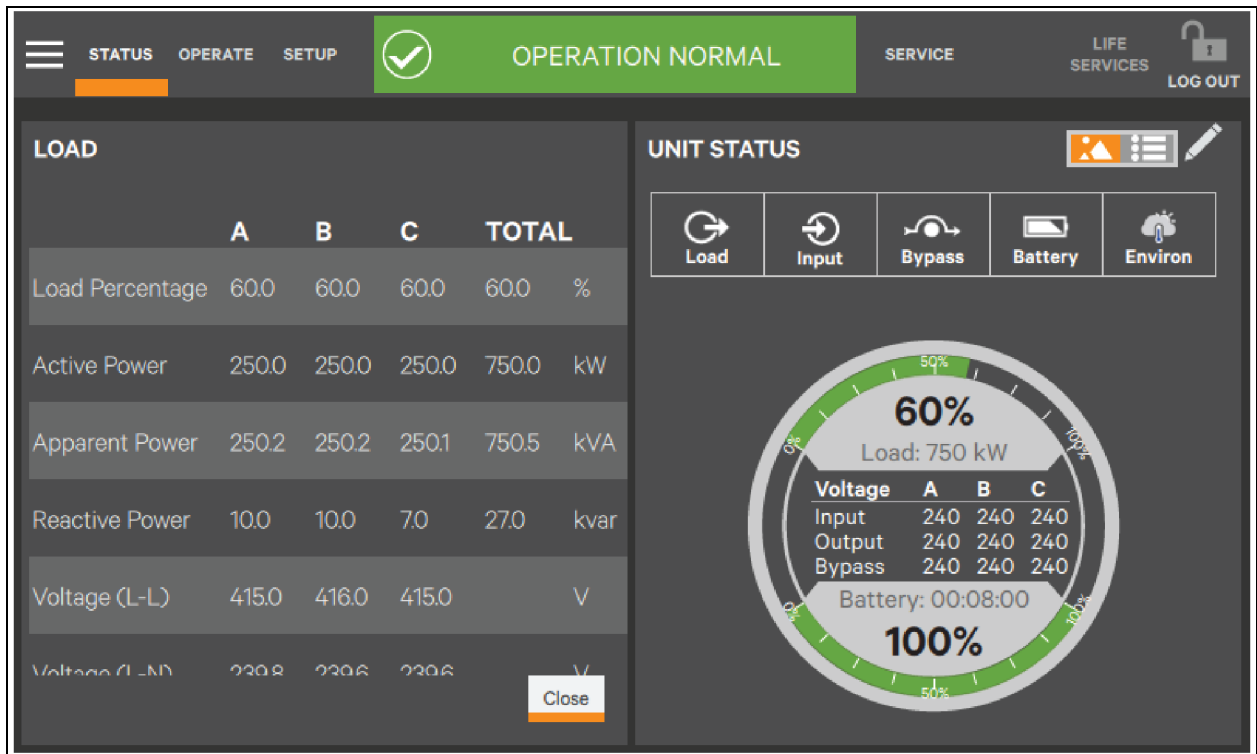

Figure 5.16 Unit Status—Load Details



5.4.4 Logs Alarms and Events

The Context Menu, when opened from the Status pane, permits viewing logs of alarms, and events that have occurred on the UPS. Both logs include the date and time of occurrence, type, an ID, component affected and a description of the alarm or event. The information is available to all users, including observers, those without a log-in passcode.

To view the alarms or events:

1. Navigate to the Status pane, if required.
2. Touch the Context Menu icon.
3. Touch the log to view, alarms or events. See **Figure 5.17** below.

Touch the logs to see the UPS event log screen.

Touch Alarms to open a list of alarms.

Figure 5.17 View Alarms or Events

Date/Time	Type	ID	Com.	Description	Wave
23/2/2 PM2:56	✓	39F1	BYP	Module Comms. Normal	
23/2/2 PM2:57	⚠	3081	HMI	Load on Bypass	
23/2/2 PM2:56	✓	3011	HMI	Silence Active	
23/2/2 PM2:56	✓	39F1	MCM	Module Comms. Normal	
23/2/2 PM2:56	⚠	2021	PM1	No Battery	
23/2/2 PM2:56	✓	39F1	PM1	Module Comms. Normal	
23/2/2 PM2:56	⚠	2021	PM2	No Battery	
23/2/2 PM2:56	✓	39F1	PM2	Module Comms. Normal	

Figure 5.18 Event Logs

Date/Time	Type	ID	Status	Com.	Description	Wave
23/2/2 PM2:57	Warning	3081	Set	HMI	Load on Bypass	
23/2/2 PM2:57	Critical	30B1	Clr	HMI	Load Off	
23/2/2 PM2:57	Critical	30B1	Set	HMI	Load Off	
23/2/2 PM2:57	Critical	39A1	Clr	HMI	Power Hardware Mismatch	
23/2/2 PM2:57	Info	10B1	Clr	PM2	Inverter in Setting	
23/2/2 PM2:57	Info	10B1	Clr	PM1	Inverter in Setting	
23/2/2 PM2:57	Info	1881	Clr	BYP	Bypass in Setting	

6 Single UPS Operation

This chapter briefly describes the operating precautions and routine operations for the Vertiv™ PowerUPS 9000 1250 kVA 415 V Modular UPS single module. For the operating precautions and routine operating methods of UPS parallel system, see [Parallel System and Load Bus Synchronization System](#) on page 101.

6.1 Introduction

NOTE: The user can perform the next operation only after the authorized engineer completes the first power ON and test of the UPS.



WARNING! Risk of electric shock and hazardous voltage of mains system and battery. The improper operation can cause equipment damage, personnel injury or death. The AC input and output terminals of the UPS have dangerous voltage. If the cabinet is equipped with an EMC filter, the filter may have dangerous voltage.



AVERTISSEMENT! Risque de choc électrique et tension dangereuse du système de réseau et de la batterie. Une mauvaise utilisation peut provoquer des dommages matériels, des blessures ou la mort du personnel. Les bornes d'entrée et de sortie en courant alternatif de l'onduleur présentent une tension dangereuse. Si l'armoire est équipée d'un filtre EMC, le filtre peut présenter une tension dangereuse.

There are no operator serviceable parts located behind the covers that require a specific tool for removal. Only a qualified service engineer can remove the covers.

For the detail operation procedure of the control keys and touchscreen, see [Operator Control and Display Panel](#) on page 59.

6.2 UPS Start-up Procedures

The Vertiv PowerUPS 9000 1250 kVA 415 V Modular UPS must be completely installed and commissioned by an authorized, Vertiv trained, engineer. The external power supply switch must be closed. After these conditions are met, the UPS can be started.

6.2.1 Start-up Procedures in Normal Mode



WARNING! These procedures result in mains voltage being applied to the UPS output terminals. If any load equipment is connected to the UPS output terminals, check with the user that it is safe to apply power. If the load is not ready to receive power, disconnect the downstream load switch and place a warning label on the connection point of the load.



AVERTISSEMENT! These procedures result in mains voltage being applied to the UPS output terminals. If any load equipment is connected to the UPS output terminals, check with the user that it is safe to apply power. If the load is not ready to receive power, disconnect the downstream load switch and place a warning label on the connection point of the load.

To start the UPS from a fully powered down condition, follow the below procedure:

1. Close the external input switch, ensure that the UPS input voltage, frequency, and phase are normal.
2. Close the output switch MIB, RBB, RFB, and all external output isolating switches (if any) of the UPS in turn.

After the HMI is fully started, touch the Log In icon to enter the system by typing correct password.

Figure 6.1 Inputting Password

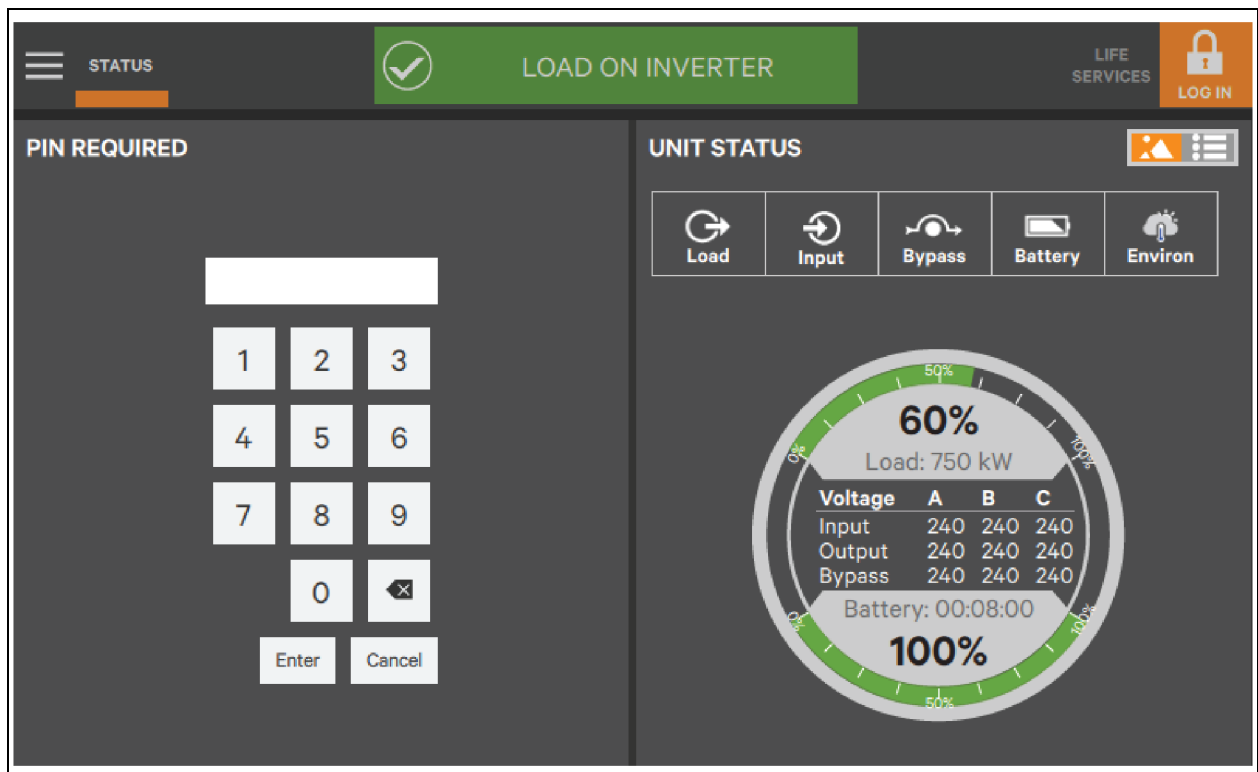

3. When the rectifier start process is finished, close the BCB and the system runs in bypass mode. See Power flow shown in **Figure 6.2** below. Touch the On. See [Operator Controls](#) on page 63 for more information.
4. From the Operate menu, touch the On button next to the Inverter On. See **Figure 6.2** below for more information.

Figure 6.2 Selecting Inverter On Key

The screenshot displays the control interface for a Vertiv PowerUPS system. The top navigation bar includes 'STATUS', 'OPERATE' (highlighted), and 'SETUP'. A prominent orange banner reads 'VIEW EVENT LOG FOR DETAILS'. On the right, there are links for 'SERVICE', 'LIFE SERVICES', and 'LOG OUT'.

The main interface is divided into two sections:

- UNIT OPERATIONS:** A list of controls with corresponding buttons:
 - Inverter On: On (white button)
 - Inverter Off: Off (white button)
 - Reset Fault: Reset (yellow button)
 - Energy Saving Status: Disabled (text)
 - Power Module Redundancy: Setup (white button)
 - Energy Saving Mode Activation: Setup (white button)
- SINGLE SYSTEM:** A schematic diagram showing the power flow. It includes components labeled MBB, RBB, RFB, BCB, MIB, and LLBB. The diagram illustrates the connection between the rectifier (RBB/RFB), bypass (BCB), and inverter (MIB) paths, leading to the output (LLBB).

A 'Legend' section is visible at the bottom of the schematic area.

- 5. The inverter starts a self-test and synchronize.

NOTE: The system can take one minute or more to synchronize when user energize the unit for the first time.

Figure 6.3 Inverter Self-Test and synchronizes

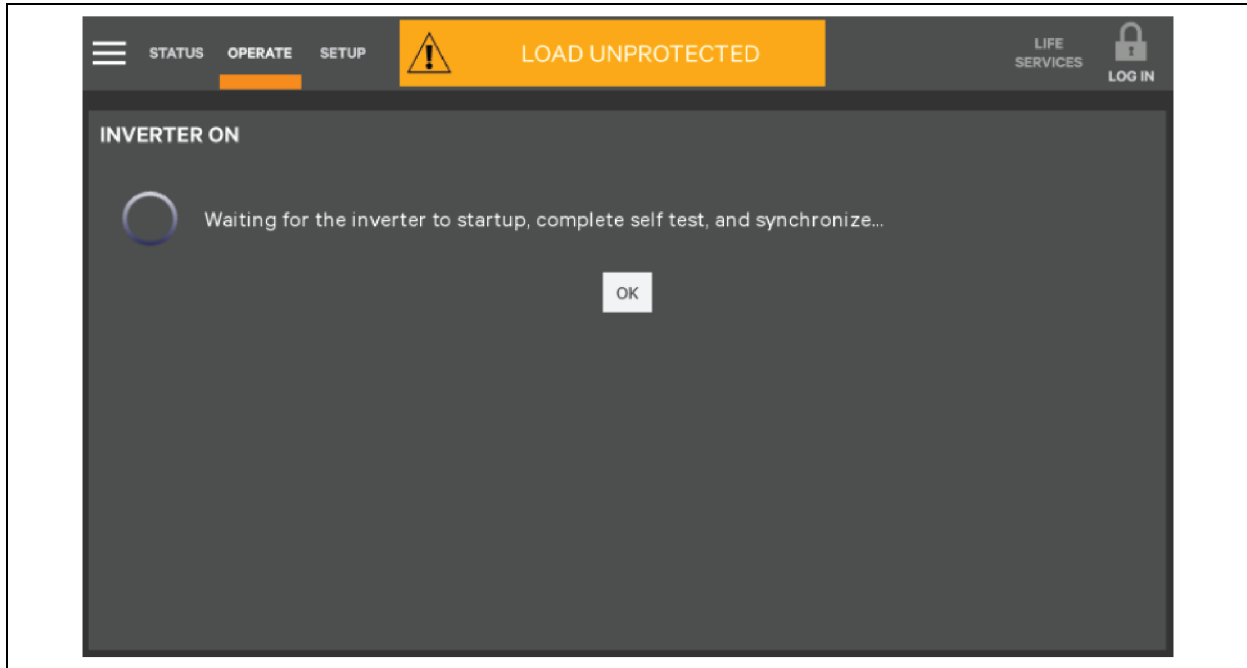

- 6. Start-up is finished.

Figure 6.4 Start Up Finished

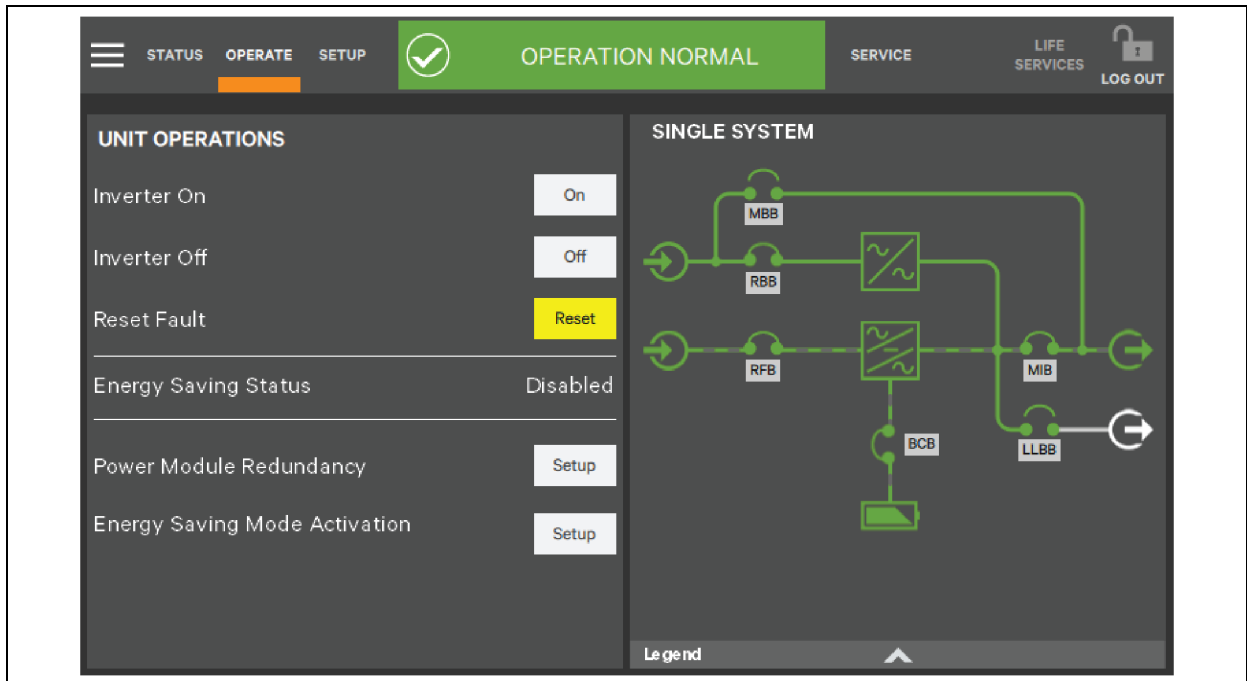

6.2.2 Start-up Procedures in Economic Mode

NOTE: In parallel UPS configuration, all operations related to disconnection or connection of the maintenance bypass switch shall be executed within 3 seconds to avoid overload situations and damage to the maintenance bypass switch.

The start-up procedure for operation in Economic mode is as follows:

1. Close the output MIB, RBB, RFB, and all external output isolating breakers (if any) of the UPS in turn.

The system is powered on, and the start-up screen activates.

2. If ECO mode is necessary, contact a Vertiv personal to activate it through the software setting. If you wish to activate it by yourself, you can enable it through the Energy Saving Mode Activation on the touchscreen. See [Operator Controls](#) on page 63 for more details.
3. Touch Setup next to the Energy Saving Mode Activation.
4. Select ECO Mode from the drop-down.
5. Touch Save.

Figure 6.5 Setting ECO Mode

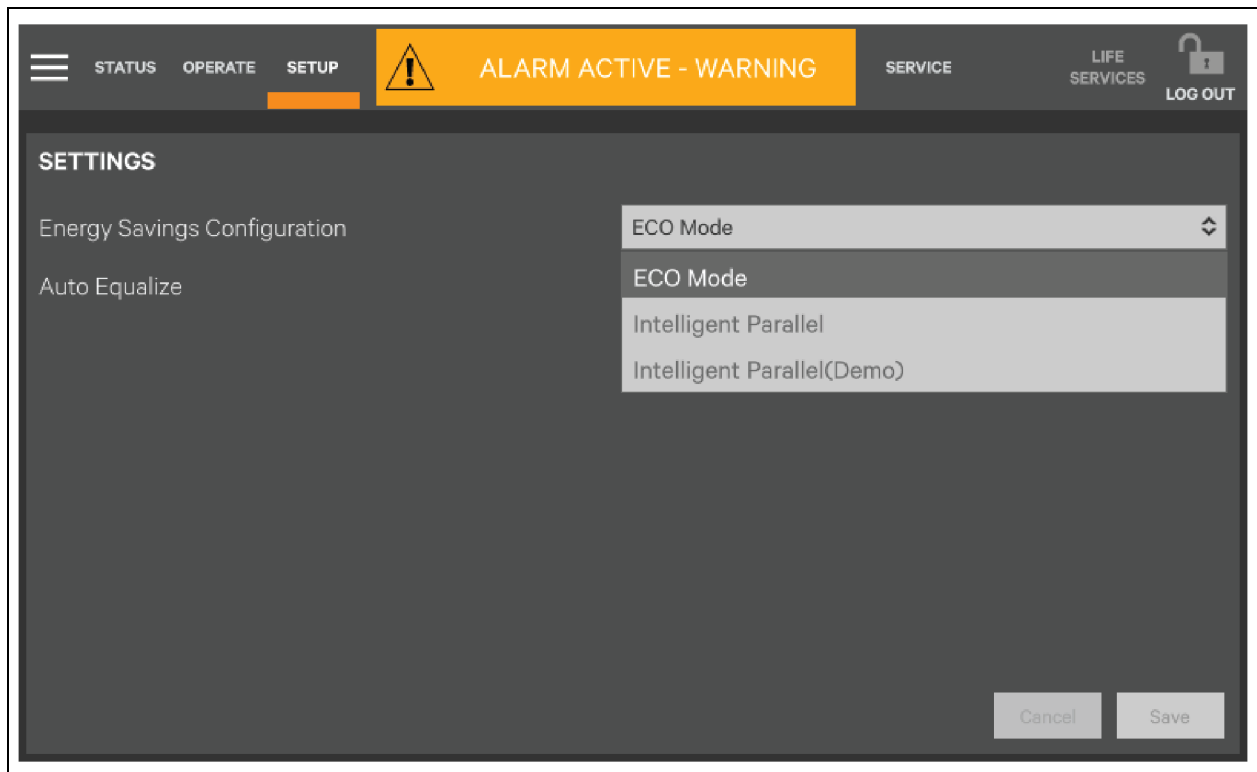

6. When the rectifier is started, start the system according to [Start-up Procedures in Normal Mode](#) on page 76.

After the inverter is running normally and if the bypass voltage is within the range of ECO power supply, then the system works in ECO mode, otherwise the system will transfer to inverter. The system will automatically work in ECO mode after the bypass voltage is within the range of ECO power supply for five minutes.

6.3 Procedures for Transfer Between Operation Modes

6.3.1 Transfer from Normal Mode to Battery Mode

Open the external power switch to isolate the mains power and initiate the UPS on battery mode. To transfer the UPS back to normal mode, close the external power switch to reconnect the mains power to the UPS. The rectifier restarts automatically in about 10 seconds and the UPS works in normal mode.

6.3.2 Transfer from Normal Mode to Bypass Mode

Procedure to transfer the load from the normal mode to the bypass mode:

1. Log in to the system as the Operator.
2. Touch the Operate tab.
3. Touch the Off button next to the Inverter Off. The UPS transfers to bypass mode. See **Figure 6.6** below.

Figure 6.6 Transfer UPS to Bypass Mode

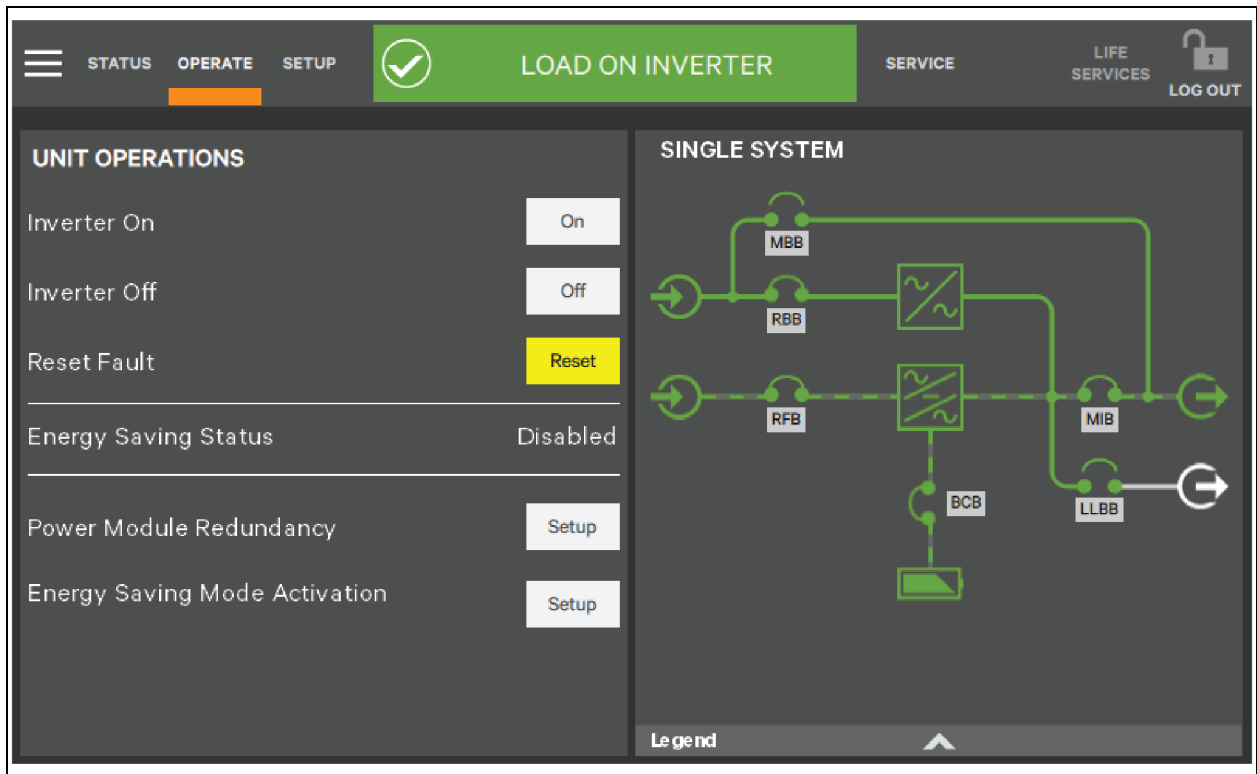

NOTE: In bypass mode, the load is directly supplied by the mains power instead of the pure AC power from the inverter.

6.3.3 Transfer from Bypass Mode to Normal Mode

Follow the procedure below to transfer the load from the bypass mode to the normal mode:

1. Activate the system and login to the system.
2. Verify that the Vertiv™ PowerUPS 9000 1250 kVA 415 V Modular UPS is in bypass mode.
3. Touch the Operate tab.
4. Touch the On button next to the Inverter On. The UPS transfers to normal mode from the bypass mode. See **Figure 6.7** below.

Figure 6.7 Transfer UPS to Normal Mode

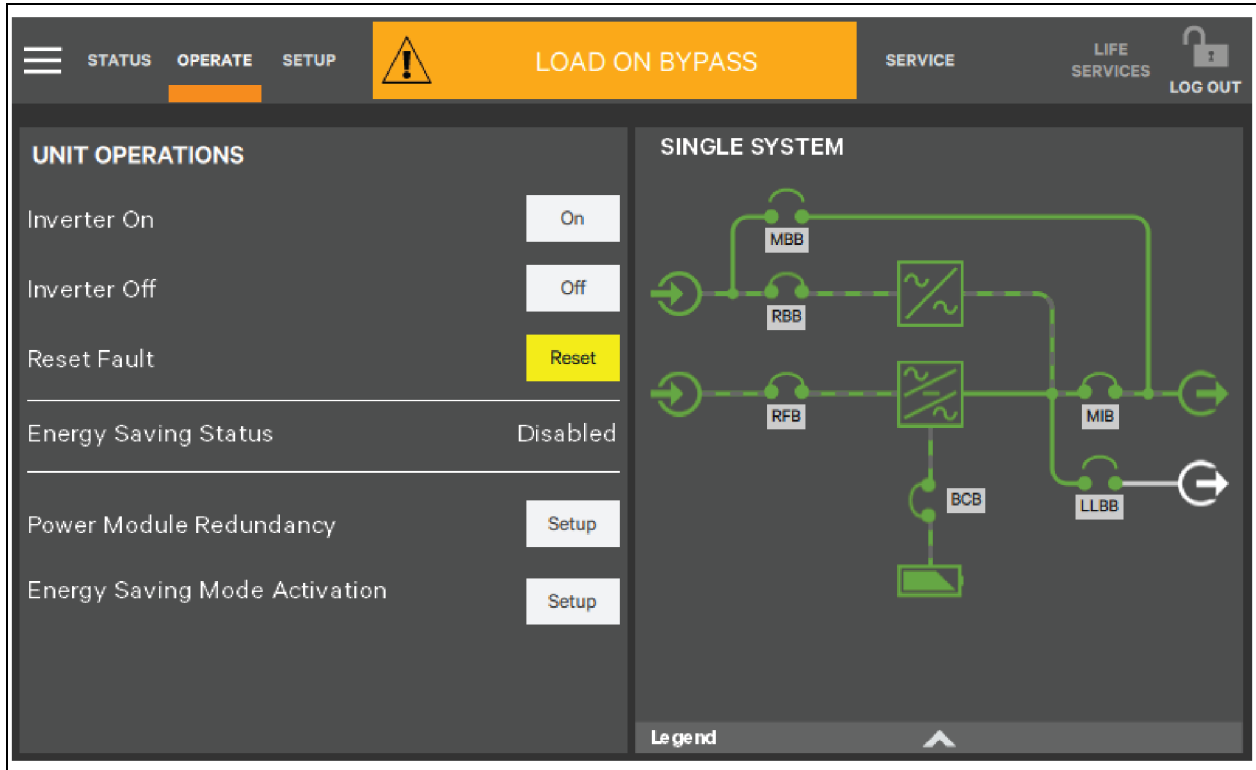

6.4 Battery Test Procedures

The battery test function is disabled by default. If you need this function, contact Vertiv's customer service.

The battery self-test includes periodical self-test and manual maintenance self-test:

- When the load factor is 0% to 20%, the system only supports manual maintenance self-test.
- When the load factor is 20% to 100%, the system supports periodical self-test and manual maintenance self-test.

The battery discharges 20% of total battery energy.

Periodical self-test is to test the battery activity. The periodical self-test is regular, and the self-test period can be configured via the Vertiv setting software. During the periodical self-test, if the battery maintenance requirement is met, the system generates audible/visual alarm and corresponding records. The periodical self-test does not update the battery curve table.

The mode of the manual maintenance self-test is like that of the periodical self-test, except for the maintenance self-test mode is started manually, and this operation is valid only one time, that is the system will not automatically start up the self-test once you exit. When the load factor is 20% to 100%, during the maintenance self-test, if the battery maintenance requirement is satisfied, the system will generate audible/visual alarm and corresponding records. The maintenance self-test does not update the battery curve table.

NOTE: The periodical self-test should satisfy the conditions of battery float charge at least 5 hours, and generator not connected, while the manual maintenance self-test just satisfies the conditions of battery fully charged.

How to do a test:

1. **Manual maintenance self-test:** Through the Touchscreen.
2. **Periodical self-test:** A self-test period can be configured via the Vertiv setting software. The range of battery self-test period is 30 days to 360 days. The default is 60 days.

Self-test start-up conditions:

1. System load rate is within 0% to 100% (manual maintenance) or 20% to 100% (periodical self-test), stable output.
2. Battery in fully charged state, battery float charge at least 5 hours and generator not connected.
3. Current system is in float charge state.

Self-test exit conditions:

1. Confirm that the system is not in self-test state for at least 10 seconds and battery mode or rectifier is closed. The system shifts to battery supply state.
2. During the self-test, the system will shift to float charge state if the load fluctuates, UPS module is overloaded or no battery discharge occurs.
3. During the self-test, if the battery voltage is lower than the calculated pre-alarm voltage, or the battery discharge exceeds the protection time, then the system will shift to float charge state.
4. The user can manually stop the maintenance test via the touchscreen.
5. During the manual maintenance self-test, when the load rate ranges from 0% to 20%, the system will shift to float charge state after the battery discharge for 5 minutes.

NOTE: After the self-test is successful, the system will fully clear the self-test interval counter. If the self-test fails this time, then exits the system; when self-test conditions are satisfied again, enters self-test once more.

Procedures for battery self-test:

1. Enter the level of **Operate**.
2. Touch the Operate icon.
3. Touch the menu icon on the upper left corner.
4. Touch the Battery Operations to display the interface shown in **Figure 6.8** below.

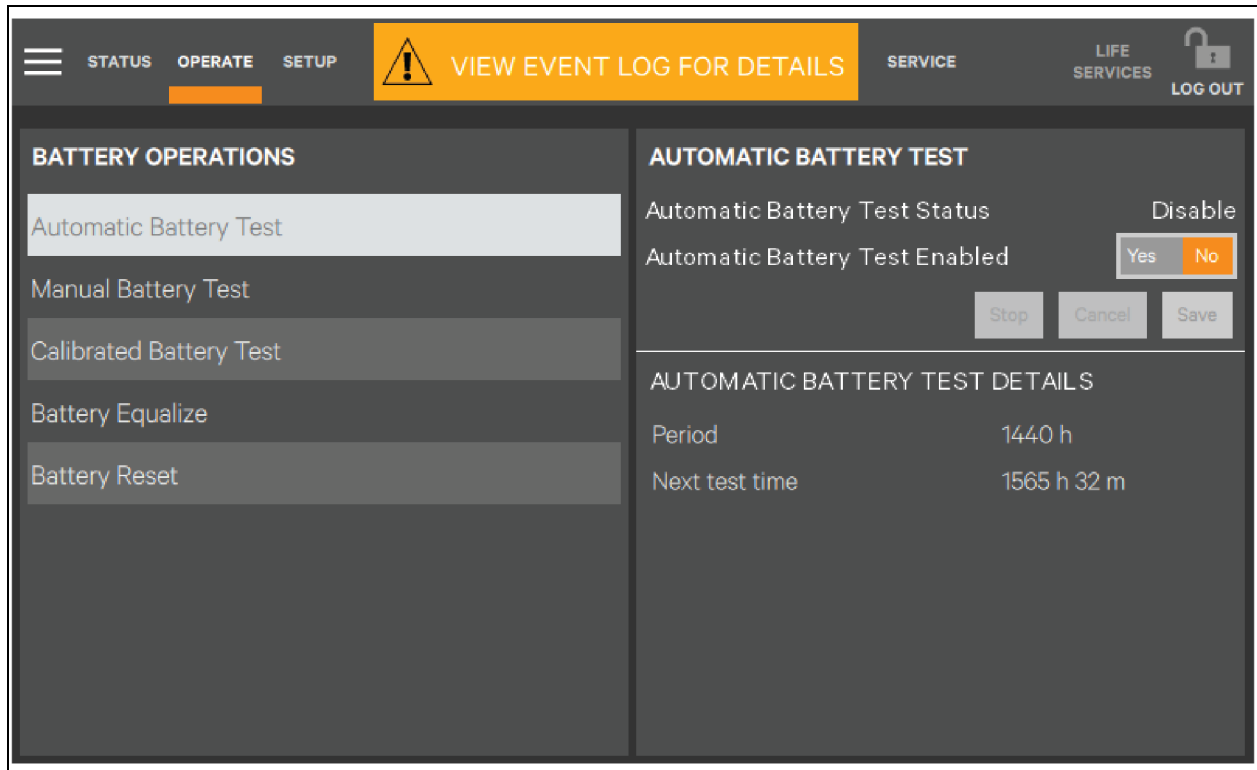
Figure 6.8 Battery Management Interface

5. Respectively touch Automatic Battery Test, Manual Battery Test, Calibrated Battery Test, and Battery Equalize, then you can execute corresponding settings and operation.

6.5 UPS Shutdown Procedures

6.5.1 Procedures to Completely Power Down the UPS

Follow the below procedure to completely shut down the UPS and load power off. All power switches, isolating switches, and breakers are disconnected, and then UPS no longer supplies power to load.

The following procedures cut off the load power completely:

1. Touch the Inverter Off key to stop the operation of the inverter. See the [Operator Controls](#) on page 63 then disconnect the external switches to stop the operation of the rectifier, static switch, and battery.
2. Now, all the internal power supply is off, and the touchscreen does not display any more.



WARNING! Hazardous battery voltage. The battery terminals still have hazardous voltage after the UPS is completely shut down.



AVERTISSEMENT! Hazardous battery voltage. The battery terminals still have hazardous voltage after the UPS is completely shut down.

NOTE: Wait 10 minutes for the internal DC bus capacitance to complete discharging. Then the UPS is completely shuts down.

NOTE: Place a lockout tagout (LOTO) at the AC input distribution (generally far away from the UPS) to alert that the UPS maintenance is being operated.

6.6 Emergency Power Off Procedures

The EPO is designed to switch off the UPS in emergency conditions (such as fire or flood). To carry out EPO, press the EPO button, then the system turns off the rectifier and inverter. Power to the load is stopped immediately (including the inverter and bypass) and the battery stops charging or discharging.

After EPO, if the input mains is present, the UPS control circuit remains active; however, the output will be turned off. To remove all power from the UPS, first disconnect the external power switch of the UPS.

6.7 UPS Reset Procedures after Emergency Power Off

After shutting down the UPS through EPO or the UPS fault condition, clear the fault according to the alarm message appearing on the touchscreen.

After confirming the fault has been cleared and no remote EPO signal is received, follow these procedures:

1. Touch the Reset Fault button. See [Operator Controls](#) on page 63. The system will exit the EPO/abnormal OFF state and the alarm indicator flashes red.
2. After the rectifier start up is finished, normally start the UPS according to [Transfer from Bypass Mode to Normal Mode](#) on page 81.

NOTE: The rectifier starts automatically when the overtemperature fault disappears five minutes after the disappearance of the overtemperature signal.

3. After the EPO button is pressed, if the mains input is switched off, the UPS shuts down completely. When the mains input is restored, the UPS enables the bypass. Restore the power at the output terminal of the UPS.

6.8 Automatic Restart

The UPS uses the battery system to supply power to the load equipment in the event of mains failure until the batteries are discharged. When the UPS reaches its EOD threshold, it will shutdown.

The UPS will automatically restart and enable output power only when the following conditions are met:

1. If Auto Recovery after EOD Enabling is enabled.
2. After the Auto Recovery after EOD Delay Time expires (the default delay is 10 minutes), the UPS restarts bypass, then inverter.
3. The BCBs do not trip open prior to the UPS EOD initiation.

NOTE: During the automatic restart process, manual start-up is disabled. Automatic restart must be set by Vertiv's authorized service engineer through Vertiv setting software.

NOTE: If used with a smart battery (Li-Ion), and the battery controls take racks offline due to battery fault, the auto restart feature will not work.

This page intentionally left blank

7 Battery

This chapter provides information about the battery, the battery types, charging/discharging, safety, installation and maintenance information, battery protection function, and the connection of BCB cabinet (option), battery temperature sensor (option), and battery ground fault detector.

7.1 Introduction

The UPS battery string consist of several batteries in series connection and provides rated DC input voltage for the UPS inverter. The required battery backup time (that is the time for battery to supply load upon mains failure) is subject to the ampere hour value of the battery. Sometimes, it is necessary to connect several battery strings in parallel.

To facilitate the UPS installation, the battery is generally installed on a specially designed battery rack or in the battery room.

During the maintenance or repair, the battery must be disconnected from the UPS. This operation is carried out with the BCB of proper capacity. This circuit breaker must be located as close as possible to the battery connecting terminal. The wiring distance of the power and signal cables connected to the UPS must be minimized.

When several strings of battery are connected in parallel to increase the battery backup time, disconnecting device shall be equipped so that the maintenance operation on a certain battery string will not affect the normal operation of other battery strings.

7.2 Safety

If you have any questions, contact Vertiv.



WARNING! Work carefully with the batteries connected to the UPS when all the blocks are connected, the battery string voltage can be up to 540 VDC. This is potentially dangerous. Follow the precautions for high voltage operation. Only qualified personnel can install and maintain the battery.



AVERTISSEMENT! Travaillez avec précaution avec les batteries connectées à l'UPS lorsqu' tous les blocs sont branchés, la tension de la chaîne de batteries peut atteindre 540 VCC. Cela est potentiellement dangereux. Suivez les précautions pour les opérations à haute tension. Seul le personnel qualifié peut installer et entretenir la batterie.

To ensure safety, the external batteries are to be installed inside a lockable cabinet or in a dedicated battery room only accessible to qualified service personnel.

Make sure that the battery switch has been disconnected before battery maintenance.

7.2.1 Safety Precautions

Observe the following safety precautions when working on the batteries:

1. The battery must be firmly and reliably connected. After the connection is completed, the screw connections between all the terminals and the batteries shall be torqued. The requirements on torque specified in the specifications or user manual provided by the battery manufacturer shall be satisfied. The connections between all the wiring terminals and the batteries shall be inspected and tightened at least once a year. Otherwise it may cause fire.
2. The battery appearance must be inspected before accepting and using the battery. Replace the battery with a new one if the package is damaged, the battery terminals are dirty, corroded, or rusted, or the shell is cracked, deformed, or leaking. Battery capacity reduction, electric leakage, or fire may occur if the damaged battery is not replaced.
3. The battery is very heavy. Use a proper method to move and lift the battery, to prevent injury or any damage to the battery terminal. Severe damage to the battery may cause fire.
4. The battery connecting terminal must not be subject to any force, such as the pulling force or twisting force of the cable, to avoid damage to the internal connection of the battery. Severe damage to the battery may cause fire.
5. The battery must be installed and stored in a clean, cool, and dry environment. Do not install the battery in a sealed battery chamber or a sealed room. The battery room ventilation must meet the requirement of EN50272-2001. Otherwise, battery bulging, fire, or human injury may occur.
6. The battery shall be installed far away from the heating products (such as the transformer), used or stored far away from any fire source, shall not be burnt or put into fire for heating. Otherwise, battery leakage, bulging, fire or explosion may occur.
7. Do not directly connect any conductor between the positive and negative terminals of the battery. Remove the finger rings, watch, necklace, bracelet and other metal items before operating the battery and ensure that tools (such as wrench) are covered with insulating material. Otherwise, battery burning, human death/injury or explosion may occur.
8. Do not disassemble, modify or demolish the battery. Otherwise, battery can short circuit, liquid leakage, or human injury may occur.
9. Clean the battery enclosure with a wringed wet cloth. To avoid static or arcing, do not use a dry cloth or duster to clean the battery. Do not use the organic solvent (such as thinner, gasoline, or volatile oil) to clean the battery. Otherwise, the battery enclosure may be cracked. In worst case, fire may occur.
10. Some battery type have diluted sulfuric acid. In normal use, the diluted sulfuric acid will be absorbed by the baffle and polar plate of the battery. However, if the battery is damaged, the acid may leak from the battery. Personal protective equipment (such as protective glasses, rubber gloves, and apron) must be used when operating the battery. If diluted sulfuric acid comes in contact with the eyes, blindness may result. If it comes in contact with the skin, burns may result.
11. The battery may have short circuit, electrolyte dry-up, or positive pole erosion failure at the end of its life. If it is still used under this state, the battery may have thermal runaway, bulging or liquid leakage. Replace the battery before it reaches this state.
12. Before connecting or disconnecting the battery connection cables, isolate the charging power.
13. Check if the battery has been unexpectedly earthed. If this is the case, remove the earth connection. Contact with any part of the earthed battery may result in an electric shock.

7.3 UPS Battery

The UPS generally adopts valve regulated battery. Valve regulated means the sealed type or maintenance free.

The valve regulated battery is not completely sealed, when it is over charged, there is gas escape. The volume of the gas escape is less than with a water injection battery. However, during the installation design of the battery, temperature rise should be considered, and enough room must be reserved to ensure good ventilation.

The valve regulated battery is not maintenance free. The valve regulated battery must be kept clean, and inspected regularly to check for corrosion and that the connection is reliable.

Batteries of different types, names or newness must not be used together. Otherwise, the battery inconsistency will cause frequent over discharge or under charge of certain battery. The battery will have premature failure and the entire string of battery will have insufficient backup time.

Batteries must be stored in a fully charged state. Batteries will lose some capacity because of self-discharge during transportation or storage. Charge the battery before use. During the storage, ensure that the ambient temperature does not exceed the range of 5 °F to 113 °F (-15 °C to +45 °C). Optimal temperature is 68 °F to 77 °F (20 °C to 25 °C). To compensate for the self-discharge of the battery during the storage, the battery must be charged every 3 months during storage. The specific time may differ for different batteries. For details, refer to the requirements of the battery manufacturer.

Fully charge the battery that will be used to test the battery backup. The test may take several days. Conduct this test after battery is float charged for at least 1 week uninterrupted.

Battery performance increases after running for several weeks or has been subject to 2 or 3 charge/discharge cycles.

To avoid the battery over charge or under charge, set the battery management parameters according to the equalizing/float charge voltage and temperature compensation factor specified in the manuals provided by the battery manufacturer. Charge the battery immediately after discharge.

7.4 Precautions for Installation Design

NOTE: Use and maintenance of the battery are described in the relevant battery manual provided by the battery manufacturer. The safety precautions described in this section include the important precautions that must be considered during the installation design. The design results may be changed according to the local situations.

7.5 Battery Installation Environment and Number of Batteries

7.5.1 Installation Environment

Fresh air volume (EN50272-2001)

The operating environment of a lead acid battery must be ventilated. During the operation of the battery, the requirement for the fresh air ventilation is:

$$Q=0.05 \times n \times I_{gas} \times C_{rt} \times 10^{-3} \text{ [m}^3\text{/h]}$$

Where:

Q - The fresh air ventilation volume per hour, the unit is m³/h

n - Number of cells

I_{gas} - The gas evolving current density under battery float charging or boost charge conditions, the unit is mA/Ah

I_{gas}=1, under the float charging condition of 2.27 V/cell

I_{gas}=8, under the boost charge condition of 2.35 V/cell

C_{rt} - 20 hours battery rated capacity

Temperature

Table 7.1 Ambient Temperature Range

Type	Temperature Value	Remark
Recommended optimal temperature	68 °F to 77 °F (20 °C to 25 °C)	The ambient temperature for the battery operation must not be too high or too low. If the average operating temperature of the battery rises from 77 °F to 95 °F (25 °C to 35 °C), the service life of the battery will be reduced by 50%. If the operating temperature of the battery is over 104 °F (40 °C), the service life of the battery will be reduced exponentially each day.
Short time allowable temperature	5 °F to 113 °F (-15 °C to 45 °C)	

Battery life is shortened with higher temperatures. Charge/discharge performance is reduced at low temperatures

The battery must be installed in cool and dry environment with the humidity less than 90% and be protected from the heat source and direct sun rays.

The ambient temperature, ventilation, space, float/boost charge voltage, and ripple current affect the battery temperature. Uneven temperature among the battery strings causes uneven voltage distribution and thus result in problem. It is important to maintain balanced temperature in the battery string. The temperature difference between batteries of different strings should be kept within 37.4 °F (3 °C). A valve regulated battery is very sensitive to temperature, should be used in 59 °F to 77 °F (15 °C to 25 °C). If the battery cabinet is installed near the UPS, the maximum design ambient temperature should be determined according to the battery rather than the UPS. That is, if a valve regulated battery is used, the indoor ambient temperature range should be 59 °F to 77 °F (15 °C to 25 °C) rather than the operating temperature range of the main equipment. A short time temperature deviation is allowable if the average temperature does not exceed 77 °F (25 °C).

NOTE: We recommended that user must consult the battery manufacturer's guidelines for the battery that is connected to your UPS.

7.6 Battery Protection

IMPORTANT! Appropriate switching devices to protect the battery from short circuit and overload must be selected. It is recommended to use the Vertiv BCB to provide better battery protection.

The battery is connected to the UPS through the BCB. The BCB is manually closed and has an electronic tripping device controlled by the UPS control circuit. If the battery is rack mounted (or is far away from the UPS cabinet), the BCB must be installed as close to the battery as possible, and the wiring distance of the power and signal cables connected to the UPS must be minimized.

The BCB has the following features:

- Isolation
- Short circuit protection
- In case the inverter is locked by a battery that is under voltage, the switch automatically disconnects in order to avoid damage due to a battery over discharge.
- If equipped with a remote EPO button, an EPO button can be used to remotely disconnect the BCB.

To obtain the required backup time, the batteries may be connected in parallel. In this case, each battery string must be connected to a separate BCB.

NOTE: Only trained personnel must operate and maintain the BCB. While some battery manufacturers may not mandate the use of a battery breaker, they typically provide an alternative method for disconnecting power flow, such as a switch or contactor. This disconnect mechanism is used alongside DC-rated fuses to protect against overcurrent and short circuits.

7.7 Battery Installation and Connection



WARNING! Only a qualified engineer should install and connect the batteries. The battery has hazardous high voltage, and requires insulated tools for safety protection.



AVERTISSEMENT! Seul un ingénieur qualifié doit installer et connecter les batteries. La batterie présente une haute tension dangereuse et nécessite des outils isolés pour la protection de sécurité.

To install and connect the batteries, perform the following steps:

1. Before installation, check the battery appearance to ensure that there is no damage, inspect and count the accessories, and carefully read this manual and documentation provided by the battery manufacturer.
2. Make sure that there is at least 0.4 in. (10 mm) gap between the batteries vertically to permit circulation.
3. Clearance should be maintained between the battery top and the upper row to facilitate monitoring and maintenance of the battery.
4. The batteries should be installed from the bottom to top to avoid a too high gravity center. The batteries should be installed to protect from vibration and shock.

7.8 Other External Battery

7.8.1 VRLA Battery Cabinet

The Vertiv™ PowerUPS 9000 1250 kVA 415 V Modular UPS supports external VRLA battery cabinet. The number of batteries, EOD voltage, and float charging voltage as shown in **Table 7.2** below.

Table 7.2 Number of Batteries

Parameter	1250 kVA 415 V
Number of cells (standard)	180 to 300, even numbers can be set consecutively; 240 to 300, UPS output power no derating
EOD voltage	1.60 VDC/Cell to 1.85 VDC/Cell, 1.67 V/cell recommended
Float charging voltage	2.2 VDC/Cell to 2.3 VDC/Cell, 2.27 V/cell recommended

7.8.2 Ni-Cd battery cabinet

The UPS supports external Ni-Cd battery cabinet. The number of batteries, EOD voltage, and float charging voltage as shown in **Table 7.3** below.

Table 7.3 Number of Batteries

Parameter	1250 kVA 415 V
Number of cells (standard)	320 to 480, even numbers can be set consecutively; 428 to 480, UPS output power no derating
EOD voltage	0.9 VDC/Cell to 1.1 VDC/Cell, 1.0 V/cell recommended
Float charging voltage	1.35 VDC/Cell to 1.45 VDC/Cell, 1.45 V/cell recommended

7.8.3 Lithium Ion Battery Cabinet

The Vertiv PowerUPS 9000 1250 kVA 415 V Modular UPS series supports EnergyCore Lithium battery series. The Vertiv™ EnergyCore Lithium 5 and Vertiv™ EnergyCore Lithium 7 are high power standby battery cabinets designed for use with UPS. EnergyCore Lithium can be defined by the requirement. Various battery modules are available in different series configurations, with increased number of battery modules allows for higher voltage and additional energy storage. Refer to the **Vertiv™ EnergyCore Lithium 5 Service Manual SL-71289** or **Vertiv™ EnergyCore Lithium 7 Service Manual SL-71370** for detail information.

7.8.4 UL 9540 Compliance

Vertiv™ PowerUPS 9000 with Vertiv™ EnergyCore Lithium 5 Series

When installed in compliance with UL 9540 requirements, the Vertiv EnergyCore Lithium 5 Series used with Vertiv PowerUPS 9000 has been Fire Propagation Tested in accordance with UL 9540A.

Testing was conducted under CSA Report No. 80132596, dated September 29, 2023.

The following system configurations are permitted:

- Vertiv EnergyCore Lithium 5 – 16 Module
Rated energy: 27.6 kWh per cabinet
Maximum configuration: 12 cabinets
Maximum system energy: 331.2 kWh per system
- Vertiv EnergyCore Lithium 5 – 18 Module
Rated energy: 33.1 kWh per cabinet
Maximum configuration: 12 cabinets
Maximum system energy: 397.2 kWh per system

Vertiv™ PowerUPS 9000 with Vertiv™ EnergyCore Lithium 7 Series

When installed in compliance with UL 9540 requirements, the Vertiv EnergyCore Lithium 7 Series used with Vertiv PowerUPS 9000 has been Fire Propagation Tested in accordance with UL 9540A.

Testing was conducted under CSA Report No. 80217568, dated September 30, 2024.

The following system configurations are permitted:

- Vertiv EnergyCore Lithium 7 – 16 Module
Rated energy: 32.6 kWh per cabinet
Maximum configuration: 12 cabinets
Maximum system energy: 391.2 kWh per system
- Vertiv EnergyCore Lithium 7 – 17 Module
Rated energy: 34.6 kWh per cabinet
Maximum configuration: 12 cabinets
Maximum system energy: 415.2 kWh per system

Vertiv™ PowerUPS 9000 with Samsung G2 Series Batteries

When installed in compliance with UL 9540 requirements, the Samsung G2 Series batteries used with Vertiv PowerUPS 9000 have been Fire Propagation Tested in accordance with UL 9540A.

Testing was conducted under UL Report No. 4788881169, dated June 2, 2021.

The following system configurations are permitted:

- Samsung G2 – 16 Modules
Rated energy: 32.6 kWh per cabinet
Maximum configuration: 8 cabinets
Maximum system energy: 260.8 kWh per system
- Samsung G2 – 17 Modules
Rated energy: 34.6 kWh per cabinet
Maximum configuration: 8 cabinets
Maximum system energy: 276.8 kWh per system

NOTICE

The UL 9540 energy storage system (ESS) requires a customer-supplied upstream input circuit breaker (feeder breaker) for field installation. The feeder breaker shall include a readily accessible manual disconnecting means.

The customer shall ensure that all Lockout/Tagout (LOTO) devices are rated in accordance with the manufacturer-specified kiloampere interrupting capacity (kAIC), as required by NFPA 70E and CSA Z462.

Before performing any electrical installation or maintenance on the ESS, verify that proper LOTO procedures are applied to:

- All upstream feeder breakers
- All downstream output breakers directly connected to the UPS
- All DC breakers associated with the battery circuit

These measures are required to ensure complete electrical isolation.

The appropriate LOTO procedure shall be determined by the equipment manufacturer for all applicable devices. The size and type of LOTO device depend on the manufacturer and rating of the disconnecting means used. Refer to the manufacturer-supplied user documentation for detailed requirements.

Arc flash ratings shall be determined as part of the customer's site arc-flash coordination study. Ground-fault detection is required in accordance with NFPA 70E and CSA Z462.

For compliance with UL 9540 ESS requirements related to DC source LOTO procedures, refer to the following approved manuals:

- Vertiv™ EnergyCore Lithium 5 Installation and Operation Manual SL-71251
- Vertiv™ EnergyCore Lithium 7 Installation and Operation Manual SL-71369
- Samsung Gen 2 LIB System for UPS – U6A4 Installation Manual 250421_REV0.26

7.9 Battery Ground Fault Detector

Vertiv provides a battery ground fault detector. It includes a mutual inductor and printed circuit board (PCB).

NOTE: If a battery ground fault detector is installed, the positive, negative and neutral battery cables from the battery into the BCB cabinet must be routed through the hole of the mutual inductor of the battery ground fault detector, while other cables must bypass the mutual inductor for connection.

Figure 7.1 Battery Ground Fault Detector for 1250 kVA

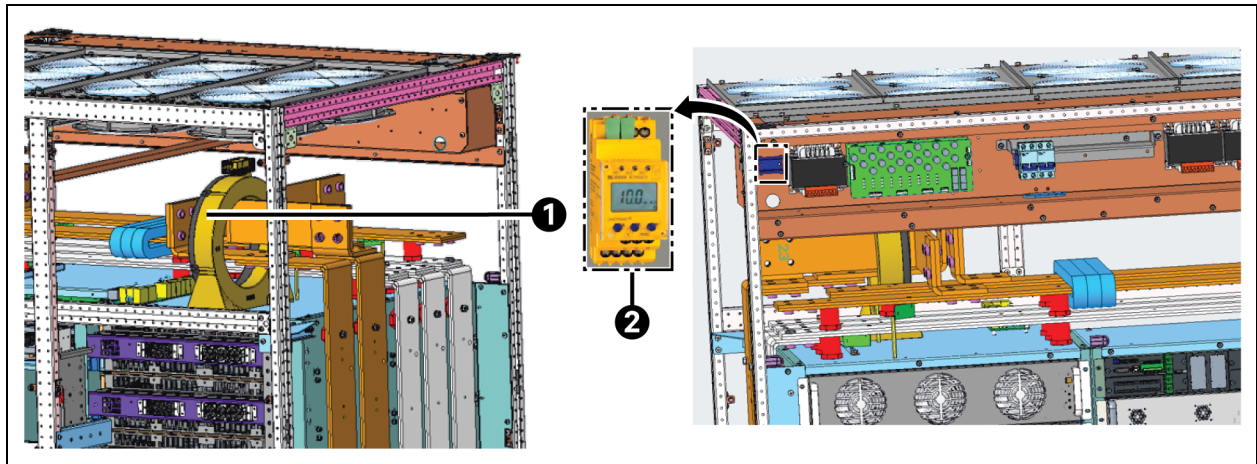

Item	Description
1	Current transformer (CT)
2	Bender controller/relay

7.10 Power Supply Units for Battery Interface Board

Vertiv™ PowerUPS 9000 1250 kVA 415 V Modular UPS provides power supply units (PSU) for BIBs in the battery cabinets. The following equipment shown in **Table 7.4** below needs to be ordered depending on the battery type and battery configuration chosen.

Table 7.4 BIB Equipment

Item	Content	Quantity
For each UPS	PSU kit (safety block, 2 power supply units, the diodes, 24 VDC 5 Amps terminals)	1
For each battery cabinet	UPS BIBX	1
	Battery temperature sensor	2

The PSU kit is installed under the top panel of UPS. The Panel on top can cover all the kit. This component is factory-installed. See **Figure 7.2** below and **Figure 7.3** on the facing page for the PSU kit structure and wiring diagram.

Figure 7.2 PSU Kit for 1250 kVA 415 V

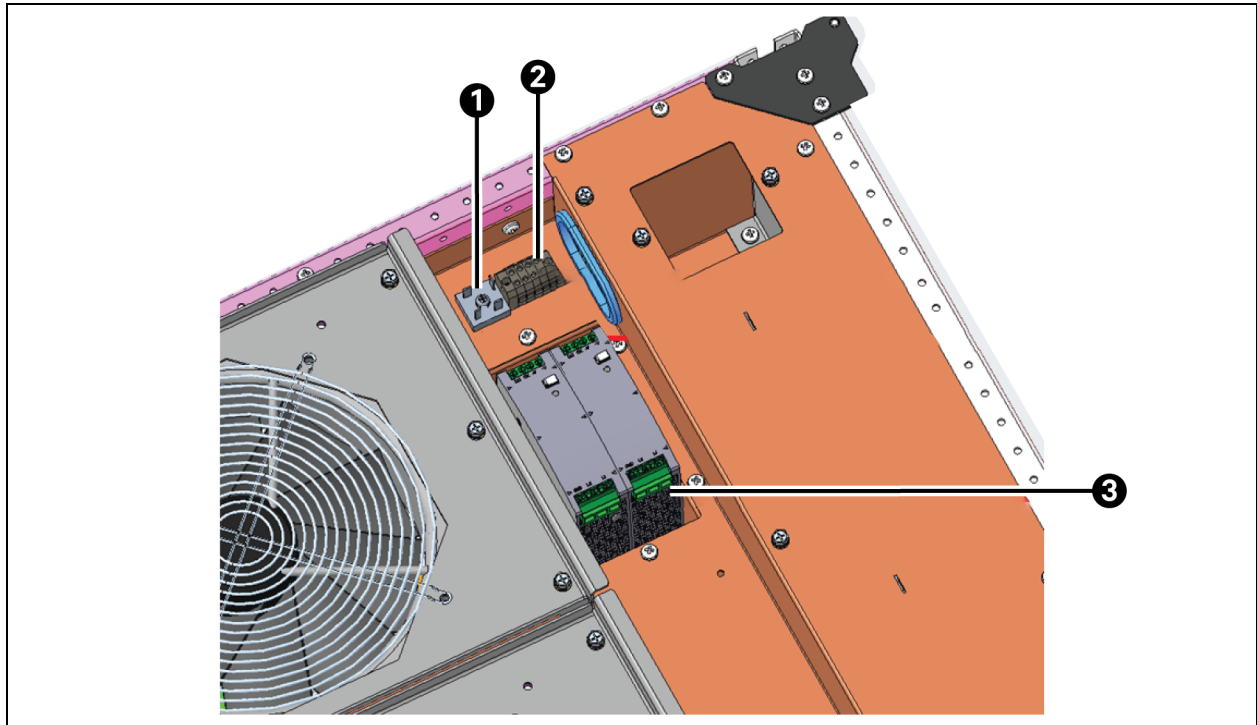

Item	Description
1	Diodes
2	24 V terminals
3	Power supply units

Figure 7.3 PSU Kit Wiring Diagram

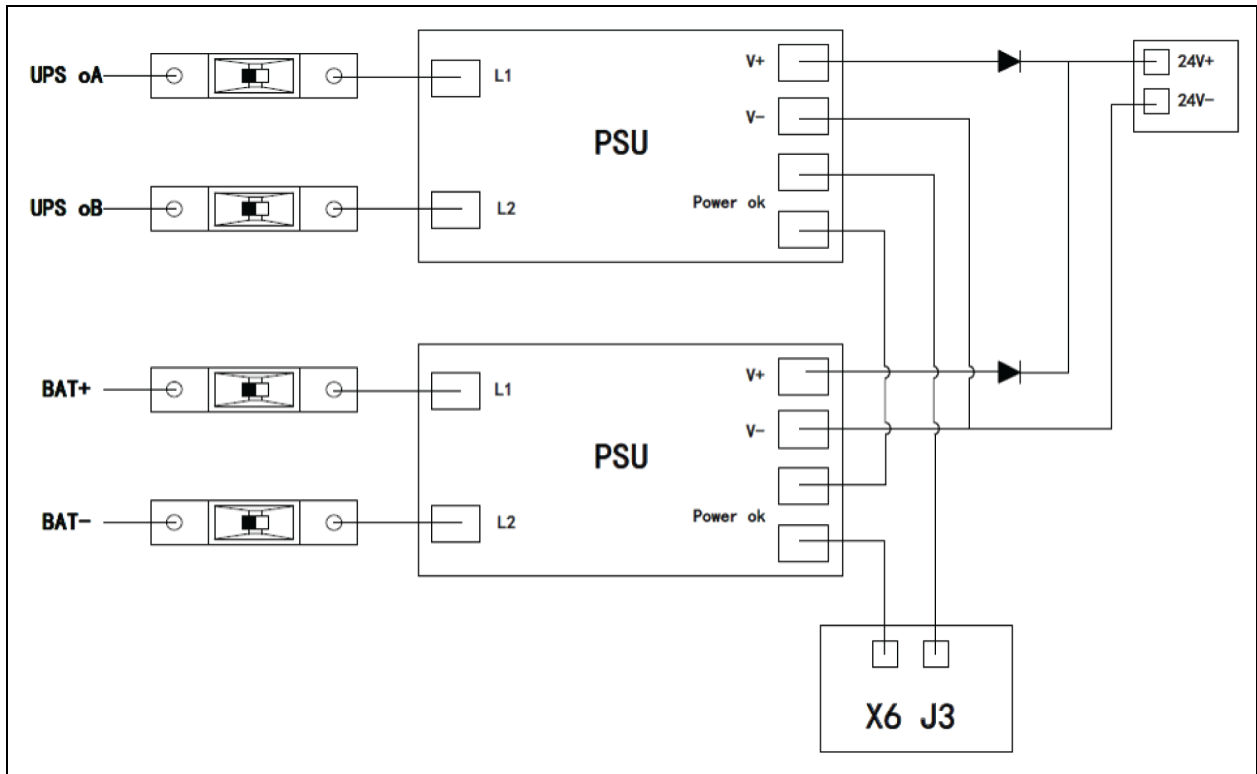

7.11 SAMSUNG and ZINCFIVE Battery BMS Power Supply

Vertiv™ PowerUPS 9000 1250 kVA 415 V Modular UPS provides power supply for SAMSUNG and ZINCFIVE battery BMS. The following shown in **Figure 7.4** below and **Table 7.5** on the facing page.

Figure 7.4 Battery Power Interface

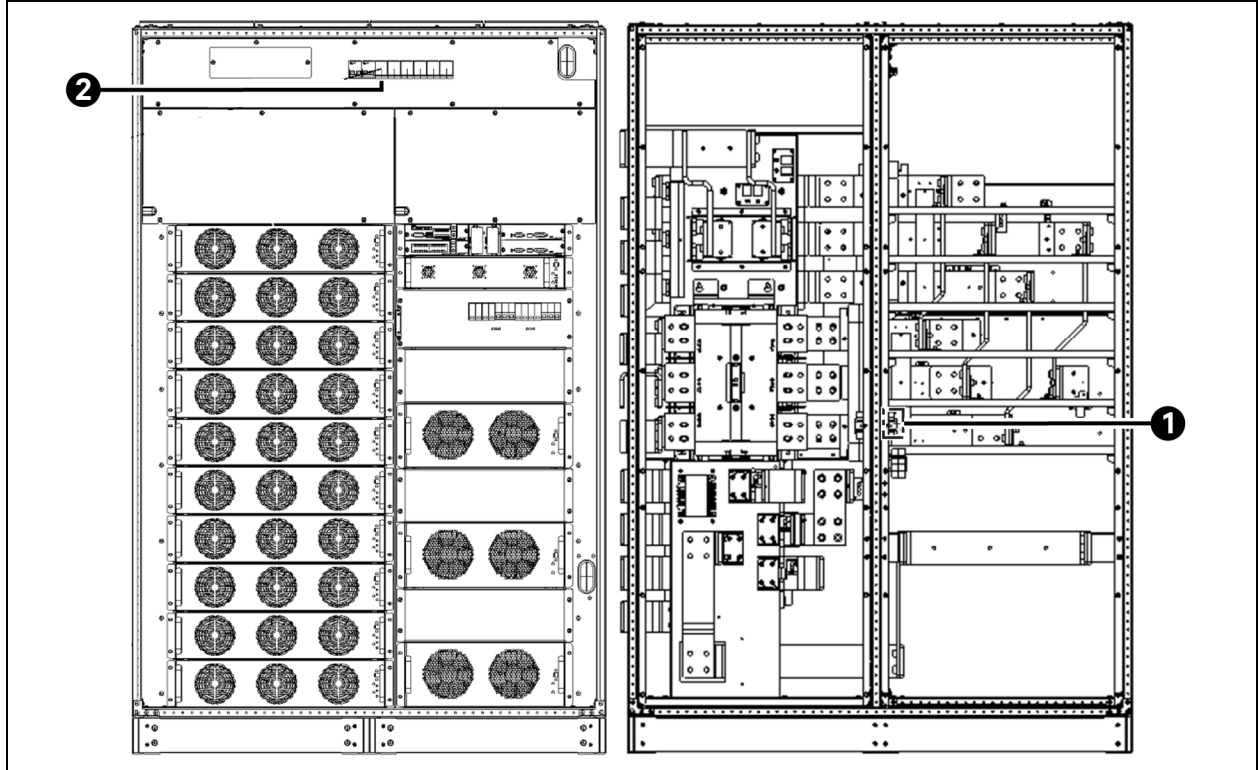

Item	Description
1	Power supply for SAMSUNG battery BMS
2	Power supply for ZINCFIVE battery BMS

Table 7.5 Fuse Port Wiring Definition

Fuse number	Port Definition	Meanings
77	mA	Power supply for SAMSUNG battery BMS
78	mB	
79	mA	
80	oA	
81	oB	
82	oC	
7	230V	Power supply for ZINCFIVE battery BMS
8	0V	
9	120V	
10	0V	

Samsung battery BMS wiring, The following shown in **Figure 7.5** on the next page, ZINCFIVE battery BMS wiring, The following shown in **Figure 7.6** on the next page.

Figure 7.5 Samsung Battery BMS Wiring

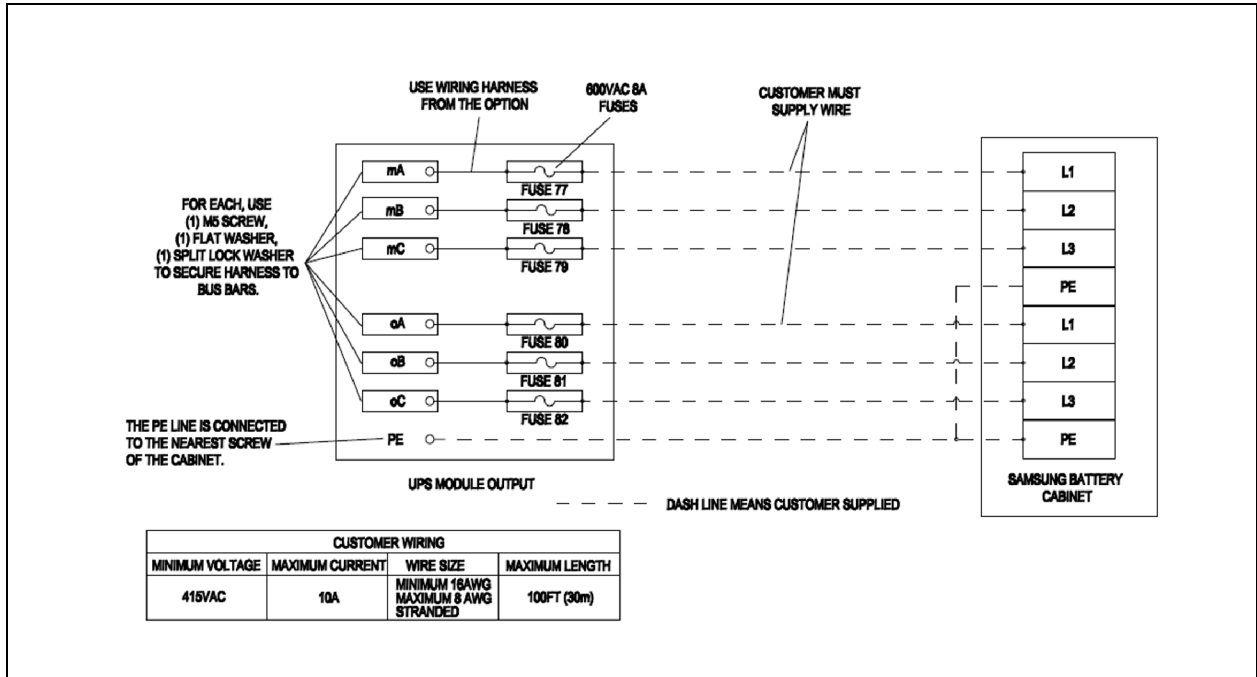
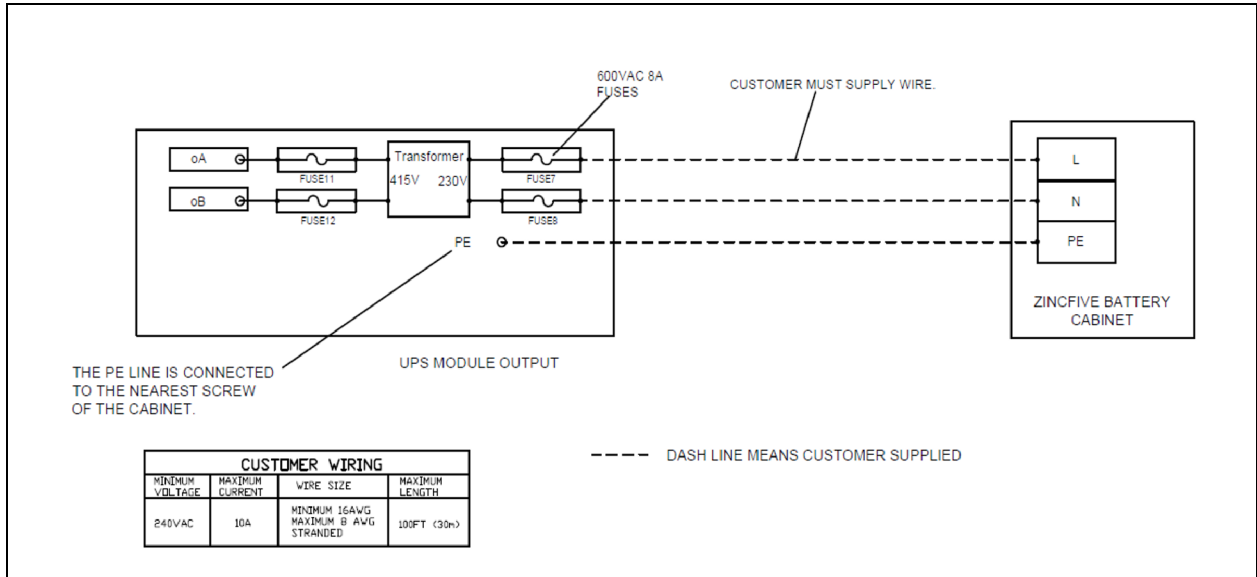

Figure 7.6 ZINC FIVE Battery BMS Wiring



8 Parallel System and Load Bus Synchronization System

This chapter gives details on the installation of the parallel system and load bus synchronization (LBS) system.

8.1 General

The parallel system is comprised of up to four UPS modules of the same power rating and connected in parallel without the need for a centralized mains static bypass. Instead, the bypass static switches of each UPS share the load when the system transfers to the mains bypass supply.

In a parallel system, each module is internally identical to the single module configuration. A parallel system requires inter-module control signals to manage the load sharing, synchronizing and bypass switching. The control signals are connected through parallel cables that are multicore ribbon cables connected between the units of the system to form a closed loop.

8.2 System Installation Procedures

The basic installation procedure of a parallel system is the same as that of a single module system. The installation of a parallel UPS should follow the installation procedure for a single UPS module with the additional requirements detailed in this section.

8.2.1 Preliminary Checks

Ensure that the selections of the parallel cables are correct, and that the modules are of the same rating, model, and with the same software and hardware release.

IMPORTANT! Vertiv service personnel must configure each module separately using Vertiv setting software to achieve coordinated operation of the modules in the parallel system.

8.2.2 Cabinet Installation

Place the UPS modules side by side and interconnect as shown in **Figure 8.1** below. The output distribution mode (MOB1 and MOB2 must be configured) shown in **Figure 8.1** below is recommended to facilitate maintenance and system testing.

Figure 8.1 Schematic of Typical Parallel System with Common Input, Separate Batteries, and Output

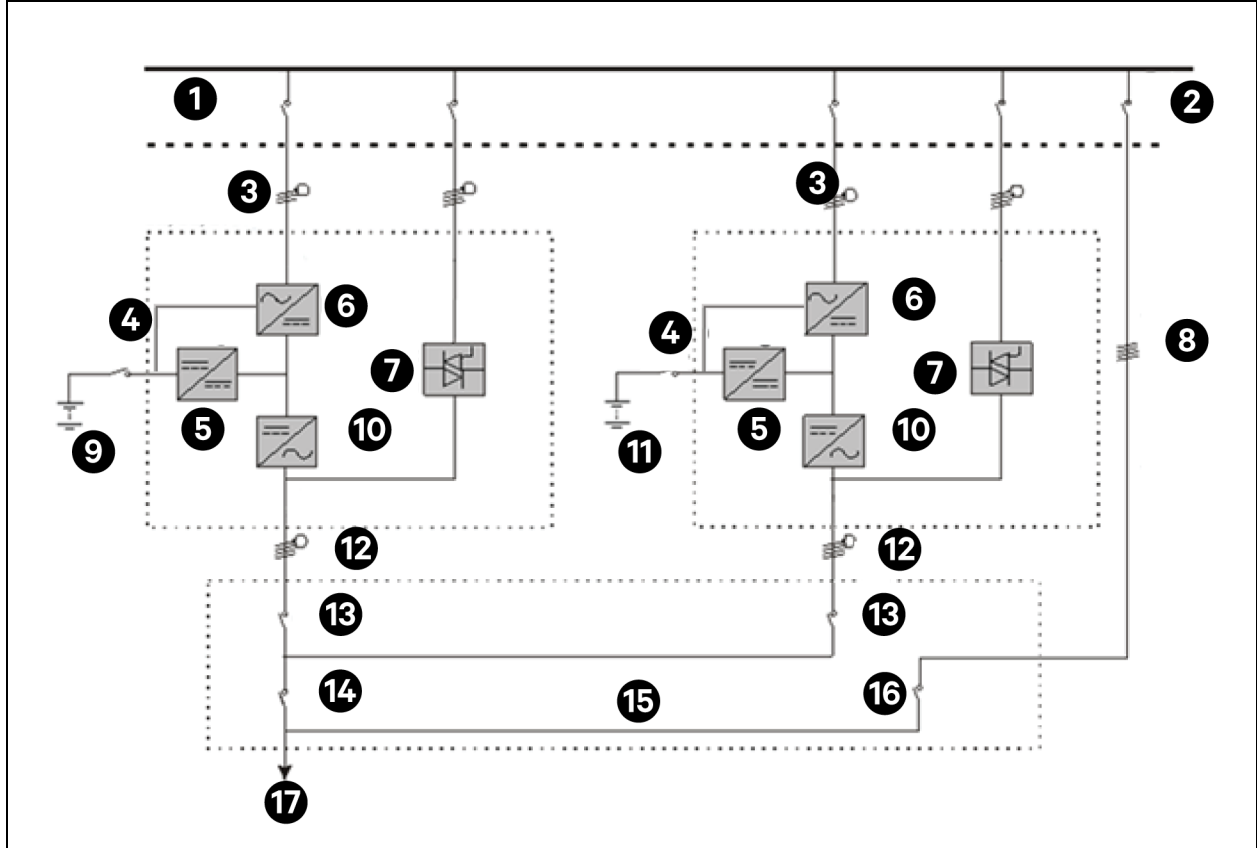

Item	Description	Item	Description
1	Input power supply	10	Inverter
2	External bypass switch	11	Battery 2
3	Mains input L1, L2, and L3	12	L1, L2, and L3
4	BCB	13	MOB1 and MOB2 ext
5	Charger	14	MIB
6	Rectifier	15	Output distribution
7	Static switch	16	MBB
8	External maintenance bypass	17	To load
9	Battery 1		

8.2.3 External Protective Device



WARNING! High earth leakage current. Earth connection is essential before connecting the input supply (including both mains supply and battery). The equipment must be earthed in accordance with the local electrical regulations.



AVERTISSEMENT! Courant de fuite de terre élevé. La connexion à la terre est essentielle avant de connecter l'alimentation d'entrée (y compris l'alimentation secteur et la batterie). L'équipement doit être mis à la terre conformément aux réglementations électriques locales.

8.2.4 Power Cable

The power cable of dual bus power system is similar to that of single system. See [Power Cable Wiring](#) on page 31 for more information.

NOTE: Vertiv advises closely managing the total differences in power cable lengths from the bypass source to each UPS and from each UPS output bus to the common system output bus to ensure the maximum variation does not exceed 20% of the total length. This helps minimize load sharing imbalances caused by impedance mismatches in parallel module bypass paths.

The bypass and rectifier input supplies must use the same neutral line input terminal. If the input has a current leakage protective device, the device should be installed upstream of the neutral line input terminal.

8.2.5 Parallel Cable

The cables must be interconnected in a ring-shaped connection between the UPS modules, as shown in **Figure 8.2** on the next page. The ring connection ensures the reliability of the control of the parallel system.

NOTE: Shielded and double insulated parallel cables are available in lengths of 16.4 ft., 32.8 ft., and 49.2 ft. (5 m, 10 m, and 15 m).

The specific connection method is the parallel cable of one single UPS is connected from the PARA1 port of the communication box to the PARA2 port of the immediate next single machine communication box and is in sequence. The front panel of the communication module provides parallel ports, as shown in **Figure 8.3** on the next page. Make sure to check all the reliable cable connections before starting up the UPS system.

Figure 8.2 Parallel Signal Cables Connection (Parallel System)

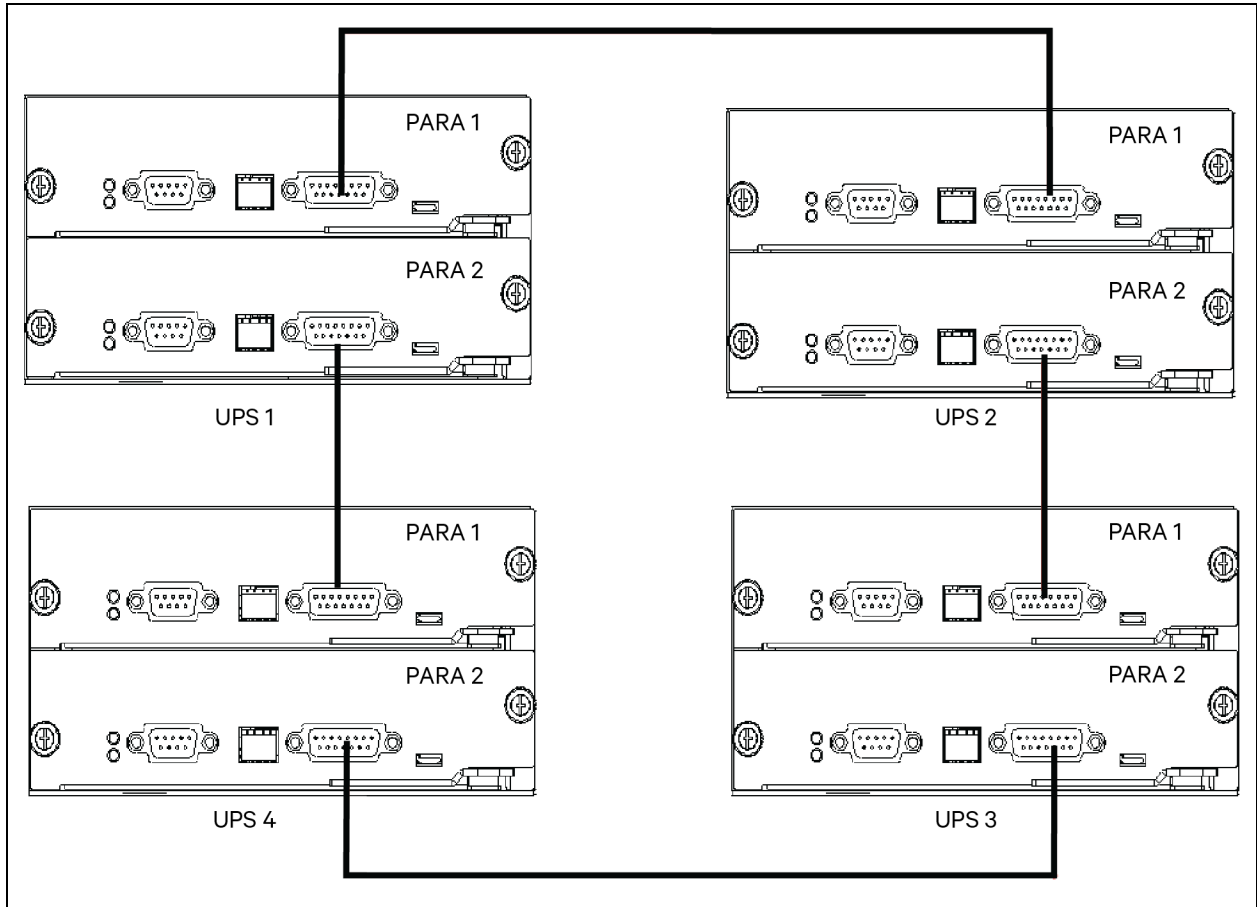
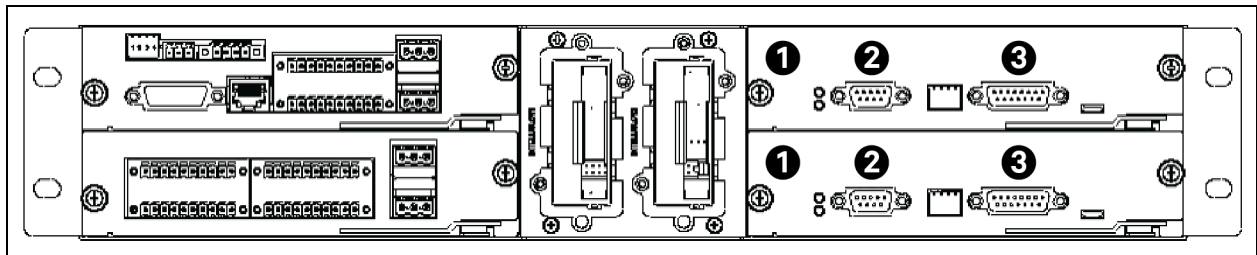

Figure 8.3 Parallel Port on the System Control Module



Item	Description
1	U4
2	LBS
3	Parallel

8.2.6 Remote Emergency Power Off

In addition to the REPO switch provided on the operator control and display panel of each UPS module for controlling the REPO of each module respectively, the parallel system also provides remote REPO function for controlling all UPS modules to shutdown simultaneously from a remote terminal, as shown in **Figure 8.4** below.

NOTE: The remote EPO switch must provide dry contact signal, which is normally open or normally closed. The open circuit voltage provided is 12 VDC, <20 mA.

NOTE: The external EPO device may consist of another control system which can disconnect UPS mains supply or bypass input. Pins 1 and 2 of the normally closed EPO port on the integrated control module is linked in factory.

Figure 8.4 REPO Circuit Diagram

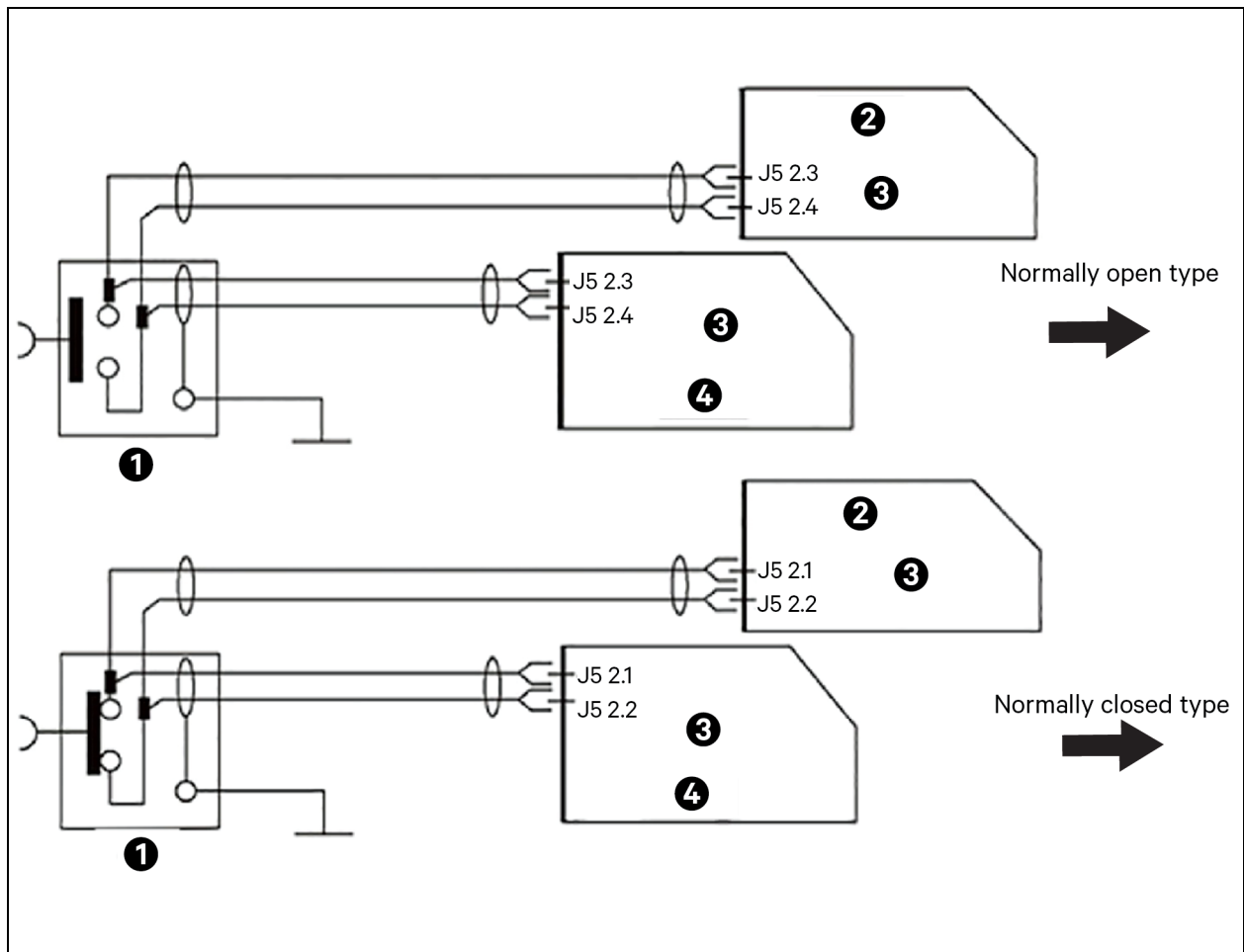

Item	Description
1	EPO switch
2	UPS 2
3	Integrated control module
4	UPS 1

NOTE: In **Figure 8.4** above, the upper one is normally open type, and the lower one is normally closed type.

8.3 Operation Procedures for Parallel System

Only one step is required at a time, and the subsequent step may only be completed when this operation step of each UPS module has been completed.

8.3.1 Start-up Procedures in Normal Mode

These procedures are applicable to start the UPS under total power down state, which means the UPS or the maintenance bypass switch has not supplied the load before. Make sure UPS has been completely installed and commissioned by authorized engineer, and external power supply switch has been turned off.



WARNING! These procedures result in mains voltage being applied to the UPS output terminals. If any load equipment is connected to the UPS output terminals, check that it is safe to apply power. If the load is not ready to receive power, open the downstream load switch and place a warning label on the connection point of the load.



AVERTISSEMENT! Ces procédures entraînent l'application de la tension secteur aux bornes de sortie de l'onduleur. Si un équipement de charge est connecté aux bornes de sortie de l'onduleur, vérifiez qu'il est sûr d'appliquer l'alimentation. Si la charge n'est pas prête à recevoir de l'alimentation, ouvrez l'interrupteur de charge en aval et placez une étiquette d'avertissement sur le point de connexion de la charge.

Procedure to turn on the UPS from a fully powered down condition:

1. Close all external input supply breakers to each UPS.

When the above steps are complete, the system is powered on, and the start-up screen boots up.

Wait 25 seconds and confirm that the touchscreen shows that the rectifier power supply and the bypass power supply are normal.

If not, check whether the RFB and RBB breakers are closed. Then the rectifier starts up, about 30 seconds after the rectifier enters normal operation, the bypass static switch is closed.

2. When the rectifier start process is finished and the rectifier indicator turns solid green, close the external BCB.
3. For each UPS, manually turn on the inverter. The inverter starts up, the whole UPS system will power the load.

8.3.2 Procedures for Isolating One UPS Module from Parallel System

IMPORTANT! The isolation procedures should be carried out only by Vertiv certified service personnel.

NOTE: Isolating a UPS module from a parallel system should only be performed if the remaining UPS modules can support the load. If not, the recommendation is to place the load on to a maintenance bypass source.

To isolate the UPS module from the parallel system, follow the steps below:

1. Turn off the inverter with the OFF button on the GHMI.

NOTE: Turning off the rectifier, inverter, static switch, and battery will not affect other UPS units in the parallel system and the load remains powered normally.

2. Disconnect the external power mains switch, external power bypass switch, BCB and single UPS external output switch.

NOTE: Place a LOTO at the AC input distribution and the UPS output MOB (generally far away from the UPS) to alert that UPS maintenance is being performed.

NOTE: Wait 10 minutes for the internal DC bus capacitors to discharge. Then the UPS is completely shutdown.

8.3.3 Adding a Single Module UPS to a Parallel System Supporting Load

To add a single UPS module to a parallel system while supporting the load, perform the following steps:

1. Connect the external power mains switch, external power bypass switch, BCB and single UPS external output switch.
2. Wait for all the modules in the UPS being added, to start with all rectifiers running.
3. Turn on the Inverter with the ON button on the GHMI.

8.3.4 Procedures for Completely Powering Down a Multi-Module UPS System

Follow this procedure to completely shutdown the UPS or supplied by a maintenance bypass wrap. Load power must be off. Disconnect all power switches, isolation switches, and breakers so that the UPS no longer supplies power to the load.

To completely power down a multi-module UPS system, perform the following steps:

1. If Load must be maintained, transfer to static bypass on all UPS systems.
2. Close the maintenance bypass breaker (MBB) for all the UPS systems.
3. Open the module isolation breaker (MIB) for the UPS systems.
4. Press the remote EPO button of each UPS to stop the operation of rectifier, inverter, static switch, and battery.
5. Disconnect the external power bypass switch and external power mains switch. At the moment, all the internal power supply is closed, and the touchscreen does not display any more.
6. Disconnect the external output switches (MOBs) for all the UPS systems.



WARNING! Hazardous battery voltage. The battery terminals have hazardous voltage even after the UPS complete shutdown.



AVERTISSEMENT! Tension dangereuse de la batterie. Les bornes de la batterie présentent une tension dangereuse même après l'arrêt complet de l'onduleur.

NOTE: Wait 10 minutes while the internal DC bus capacitance fully discharges. Then the UPS is completely shutdown.

NOTE: Place a LOTO at the AC input distribution and the UPS output MOBs (generally far away from the UPS) to alert that the UPS maintenance is being performed.

8.4 Load Bus Synchronization System

8.4.1 Cabinet Installation

An LBS system consists of two independent UPS systems, each containing one or more parallel UPS modules, as shown in **Figure 8.5** below and **Figure 8.6** on the facing page. The LBS system is highly reliable and applicable to the load with multiple inputs. For single input load, a STS can be installed to feed power to the load.

The system uses the LBS cables to keep the output of two independent UPS systems in synchronization. One set of UPS system (single/parallel) is designated as the primary, the other set of UPS system (single/parallel) is designated as the secondary for the operation in LBS mode.

Figure 8.5 LBS System (UPS Module)

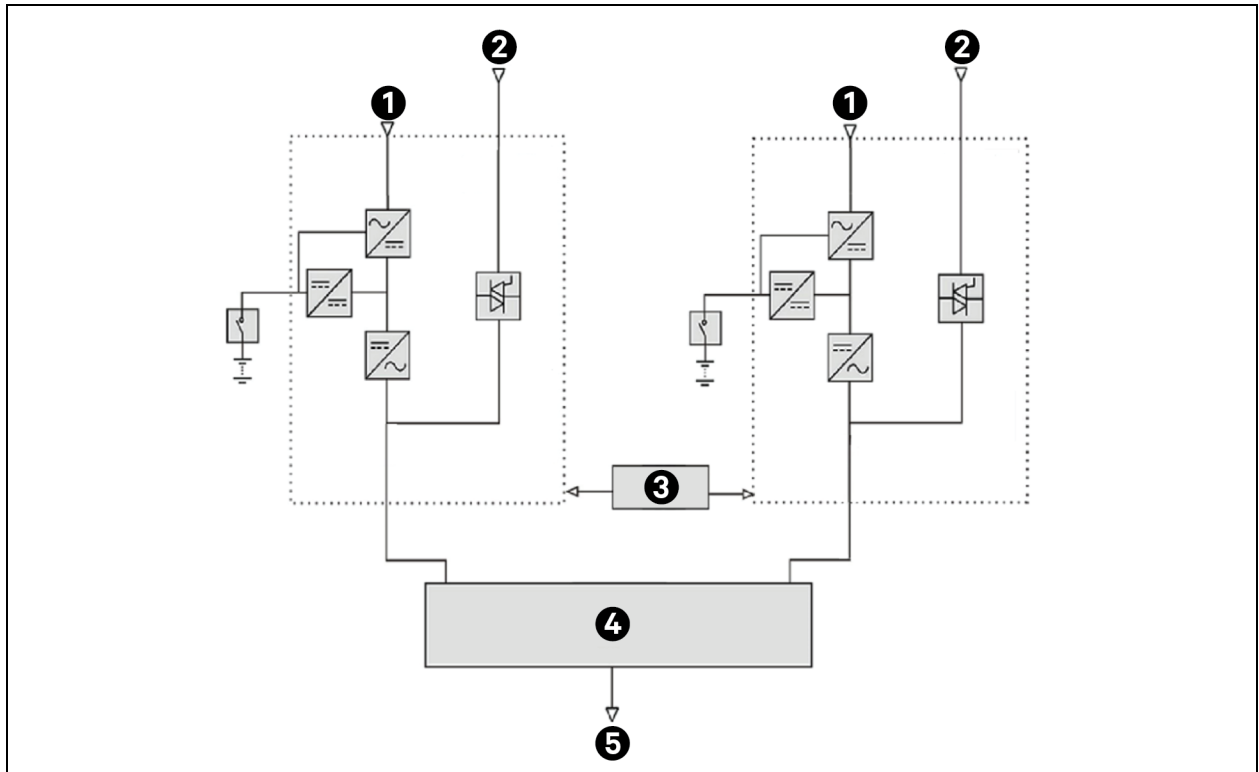

Item	Description	Item	Description
1	Rectifier	4	STS
2	Bypass	5	To load
3	LBS		

Figure 8.6 LBS System (Parallel System)

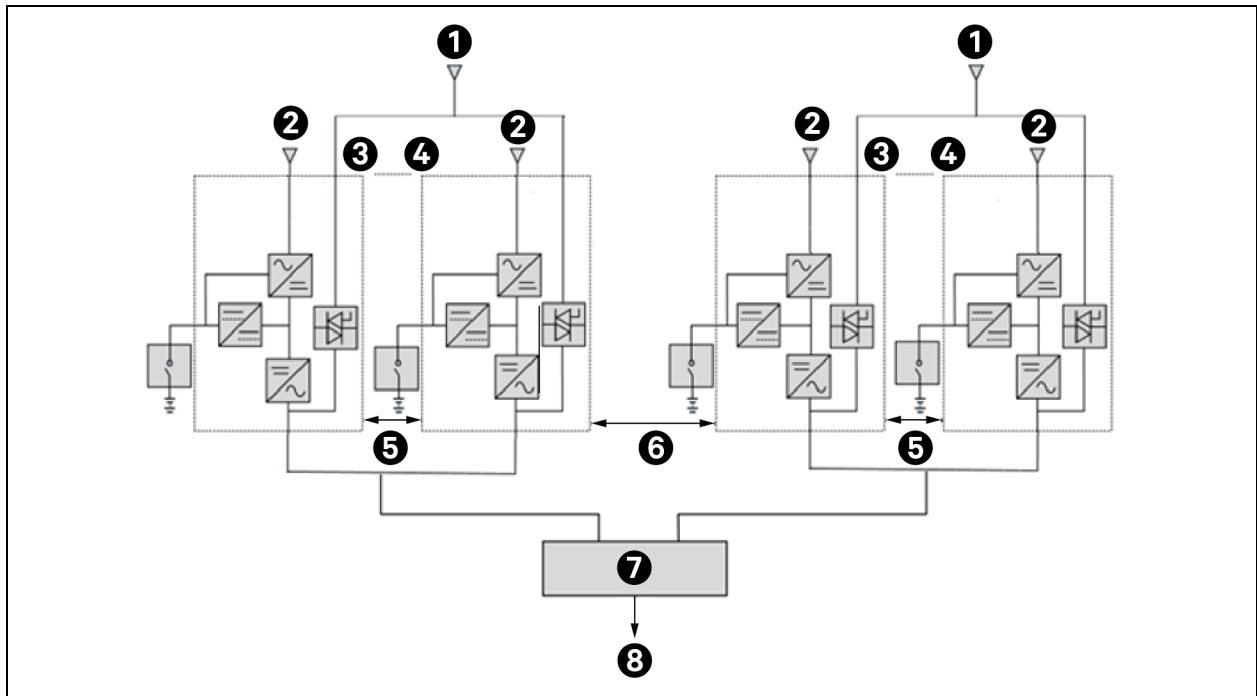

Item	Description	Item	Description
1	Bypass	5	Parallel cable
2	Rectifier	6	LBS
3	UPS1	7	STS
4	UPS4	8	To load

NOTE: In a dual bus system, the two UPS systems must have the same voltage and frequency, and the load must not exceed the power rating of a UPS module system.

8.4.2 External Protective Device

See [External Protective Devices](#) on page 40.

8.4.3 Power Cable

The power cable of dual bus power system is similar to that of single system. See [Power Cable Wiring](#) on page 31 for more information.

NOTE: Vertiv advises closely managing the total differences in power cable lengths from the bypass source to each UPS and from each UPS output bus to the common system output bus to ensure the maximum variation does not exceed 20% of the total length. This helps minimize load sharing imbalances caused by impedance mismatches in parallel module bypass paths.

The bypass and rectifier input supplies must use the same neutral line input terminal. If the input has a current leakage protective device, the device should be installed upstream of the neutral line input terminal.

8.4.4 Load Bus Synchronization Cable

Connect the optional LBS cables 32.8 ft., 49.2 ft., and 65.5 ft. (10 m, 15 m, and 20 m) between the LBS ports or PARA2 and LBS port of the two UPS systems, for dual bus system, shown in **Figure 8.7** below and **Figure 8.8** on the facing page. The LBS port is shown in **Figure 8.9** on page 112.

NOTE: You must use the shortest LBS cable suitable for the application. Do not coil excess. Separate the LBS cable from the power cables to prevent electrical interference.

Figure 8.7 Connection of Typical LBS System (Single Module)

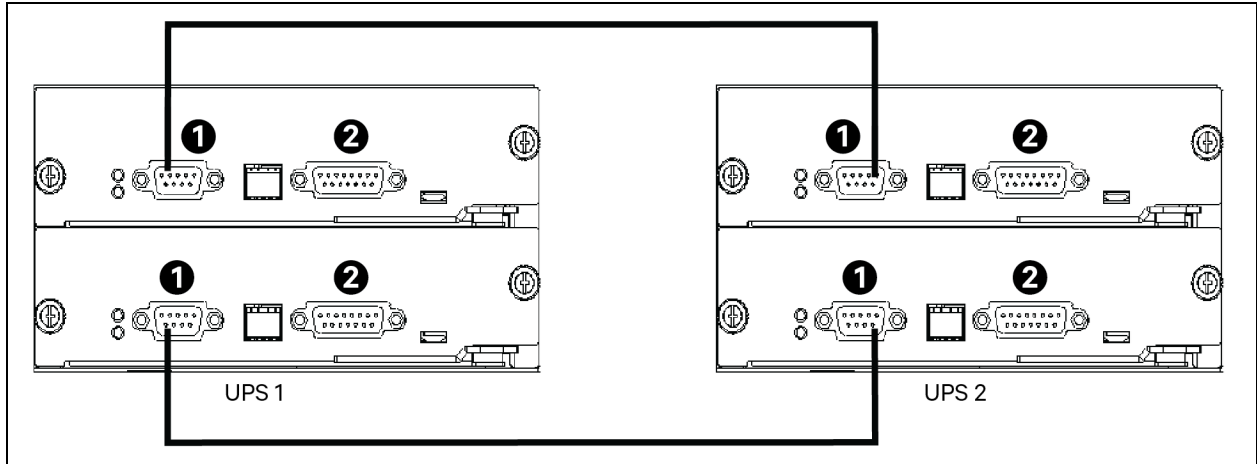

Item	Description
1	LBS
2	Parallel

Figure 8.8 Connection of Typical LBS System (Parallel System)

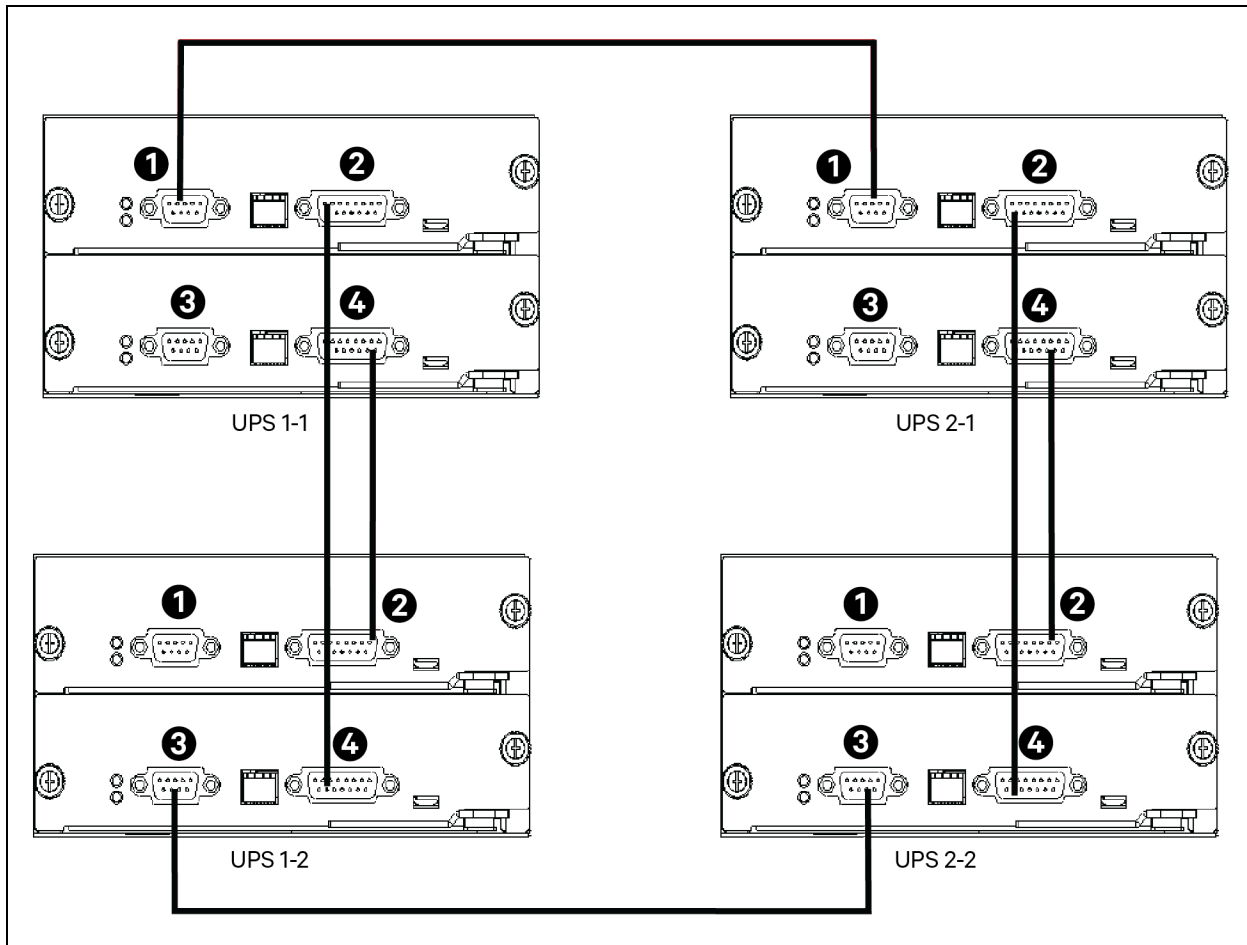

Item	Description
1	LBS1
2	Parallel 1
3	Parallel 2
4	LBS2

Figure 8.9 LBS Port

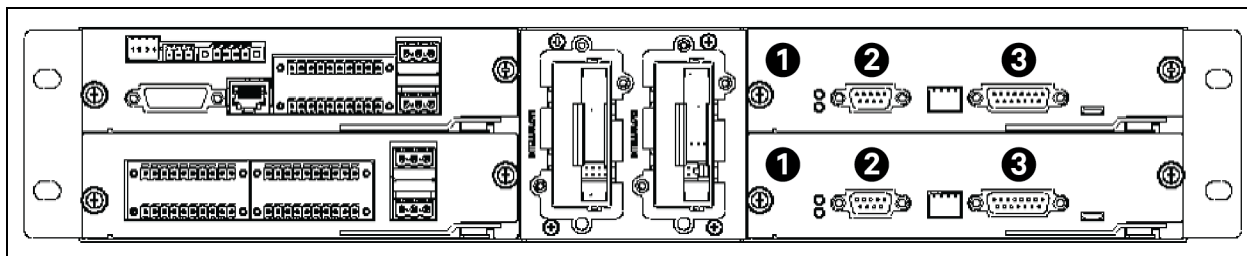

Item	Description
1	U4
2	LBS
3	Parallel

9 Vertiv™ PowerUPS 9000 1250 kVA 415 V Modular UPS Option Configurations

This chapter provides information about available options for the Vertiv PowerUPS 9000 1250 kVA 415 V Modular UPS.

9.1 Options List

Table 9.1 Options List

Number	Option Name	Remark
1	Seismic anchor kit	—
2	Vertiv™ Liebert® IntelliSlot™ IS-RELAY card	Ports 1 to 2
3	Vertiv™ Liebert® IntelliSlot™ RDU120 Card	Port 1
4	Parallel cable	Available in 16.4 ft., 32.8 ft., and 49.2 ft. (5 m, 10 m, and 15 m)
5	LBS cable	Available in 32.8 ft., 49.2 ft., and 65.5 ft. (10 m, 15 m, and 20 m)
6	Single input busbar kit	—
7	Bypass backfeed protection component	—

9.2 Options Introduction

9.2.1 Seismic Anchor Kit

The Vertiv PowerUPS 9000 1250 kVA 415 V Modular UPS provides seismic anchor kits to avoid and reduce the damage to UPS caused by earthquake or vibration.

Fix the UPS onto the concrete floor.



WARNING! Only Vertiv authorized engineers are to perform installation to avoid personal injury or damage to the UPS and seismic anchor kits.



AVERTISSEMENT! Seuls les ingénieurs autorisés par Vertiv doivent effectuer l'installation afin d'éviter des blessures personnelles ou des dommages à l'onduleur et aux kits d'ancrage sismiques

Preparation:

1. Prepare the installation tools, including a cross-head screwdriver, a torque spanner and an adjustable spanner.
2. Check that all installation materials are present and complete, including: twelve seismic brackets, ten seismic components inclined beam 1, thirty-two M8 x 25 combination screws, forty M6 x 12 self-tapping locking screws, and twenty M12 expansion bolts.

Installing the seismic anchor:

1. Secure bracket 1 to the floor using M12 expansion bolts. Use M8 x 25 screws to install bracket 2 on the rear bottom side of the UPS cabinet. Then fasten the inclined beams to the lower part of the cabinet with M6 self-tapping locking screw and connect the cabinet with bracket 1 on the floor with M12 expansion bolts. For more information see **Figure 9.1** below.

Figure 9.1 Seismic Anchor Dimensions for Vertiv™ PowerUPS 9000 1250 kVA 415 V Modular UPS (Rear Installation)

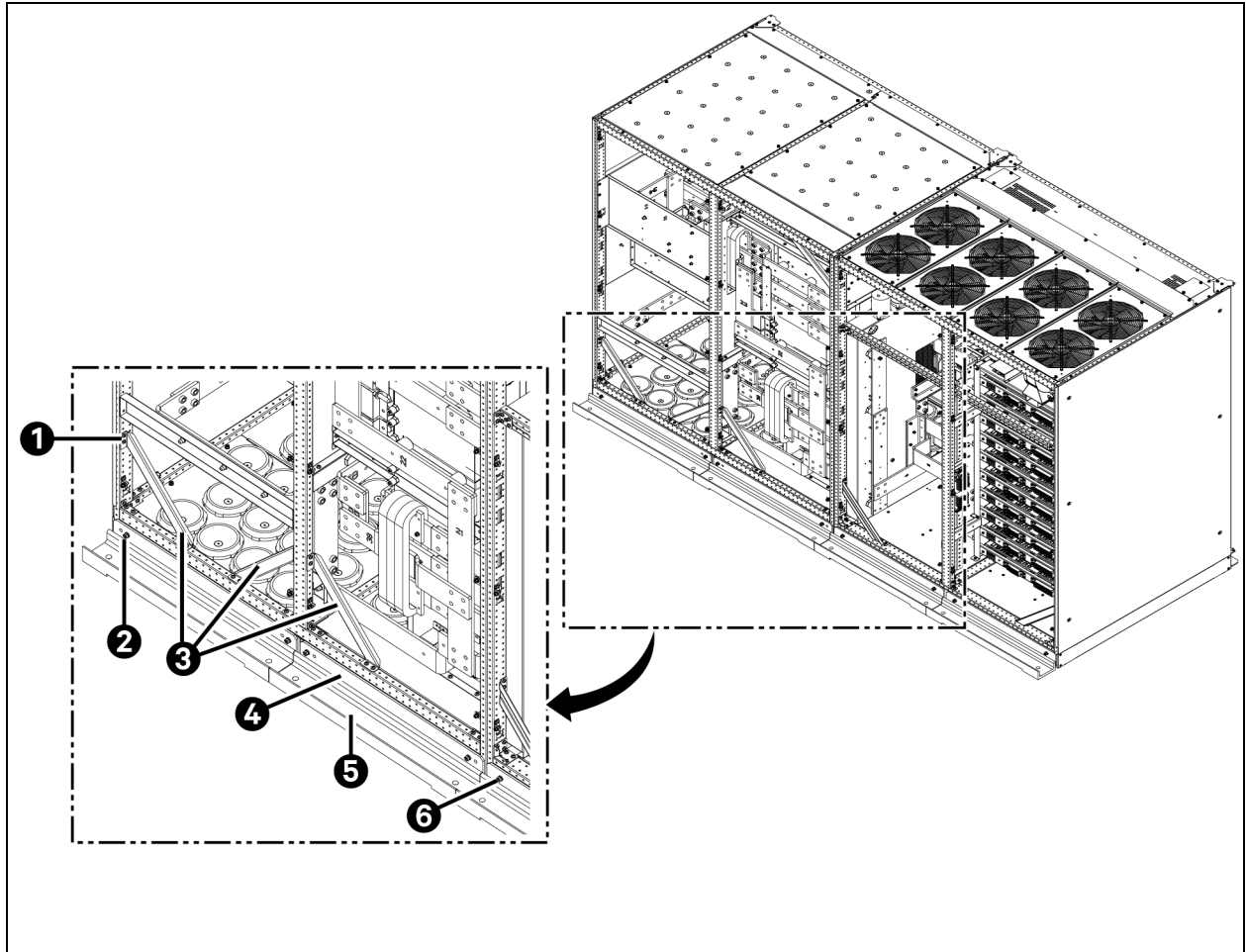

Item	Description	Quantity
1	M6 x 12 self-tapping locking screws	16
2	M8 x 25 screws	16
3	Inclined beam	4
4	Bracket 2	4
5	Bracket 1	4
5	M12 expansions screws	8

- Use M8 x 25 screws to install bracker 3 on the front bottom of the UPS cabinet. Then fasten the inclined beams to the lower part of the cabinet with M6 self tapping locking screws, finally fasten the bracket 3 to the ground with M12 expansion bolts. For more information, see **Figure 9.2** below.

Figure 9.2 Seismic Anchor Dimensions for Vertiv™ PowerUPS 9000 1250 kVA 415 V Modular UPS (Front Installation)

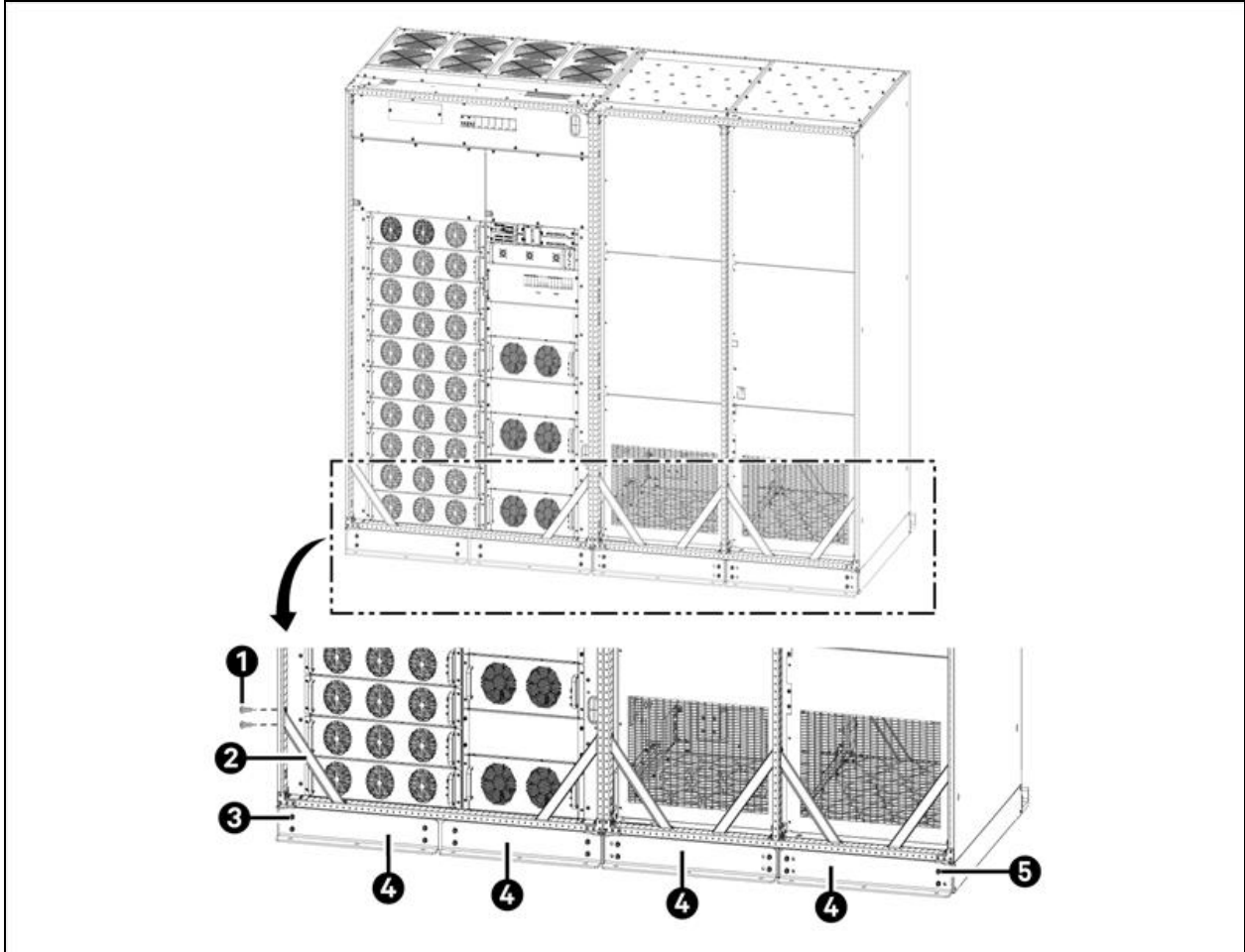

Item	Description	Quantity
1	M6 x 12 self-tapping locking screws	24
2	Inclined beams	6
3	M8 x 25 screws	16
4	Brackets 3	4
5	M12 expansions bolts	12

Install the brackets as shown in the **Figure 9.3** below.

Figure 9.3 Detailed View of Brackets

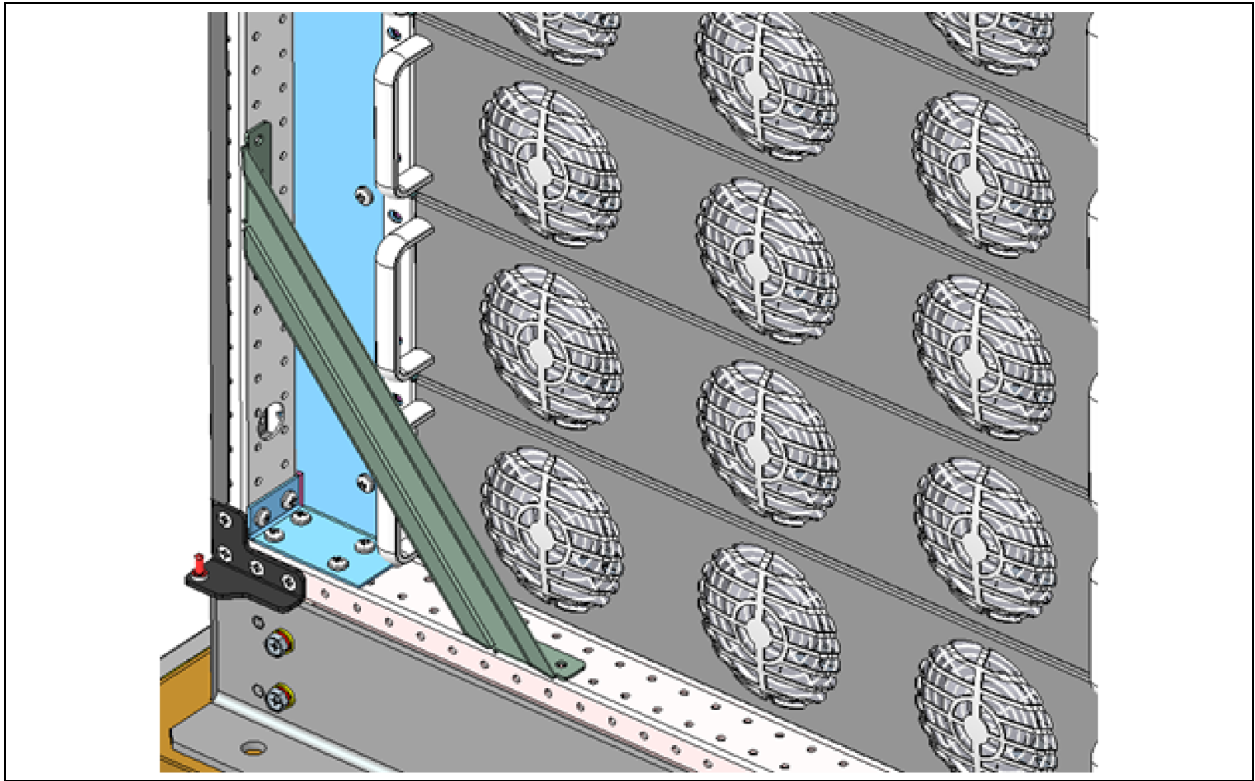

The bottom installation dimensions of the seismic anchors are shown in **Figure 9.4** below.

Figure 9.4 Seismic Anchor Dimensions for Vertiv™ PowerUPS 9000 1250 kVA 415 V Modular UPS (Bottom Installation)

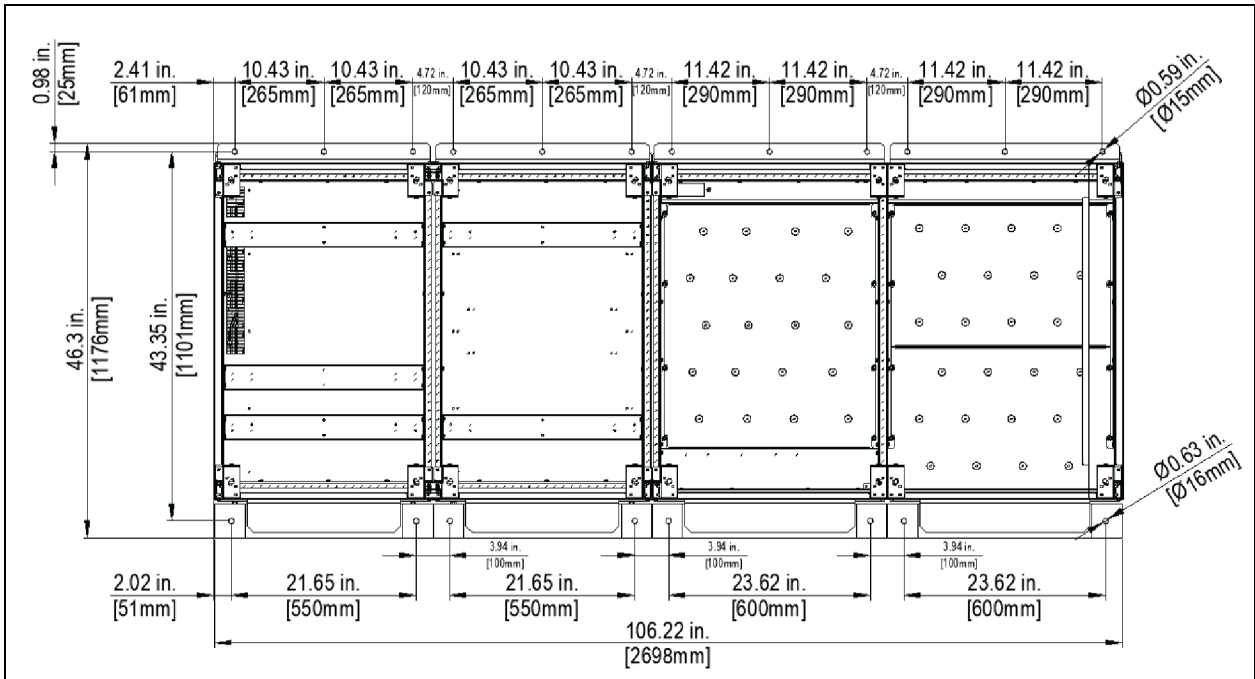

9.2.2 Vertiv™ Liebert® IntelliSlot™ IS-Relay Card

Vertiv™ PowerUPS 9000 1250 kVA 415 V Modular UPS has an optional Vertiv Liebert IntelliSlot IS-Relay card to use the dry contact signal to monitor the UPS functionalities. The functions of the Vertiv Liebert IntelliSlot IS-Relay card are listed in **Table 9.2** below. See **Figure 9.5** below for more information of Vertiv Liebert IntelliSlot IS-Relay card.

Figure 9.5 Vertiv Liebert IntelliSlot IS-Relay Card



Table 9.2 Function of UPS Vertiv Liebert IntelliSlot IS-Relay Card

Pin	Function	Operation
1	Common-Low Battery	—
2	Low Battery	Closed if low battery point occurs
3	Low Battery	Closed if battery is OK
4	Common-UPS Fault	—
5	UPS Fault	Closed if UPS fault occurs
6	UPS Fault	Closed if no UPS failure
7	Common-On Battery	—
8	On Battery	Closed if On Battery power (Utility failure)
9	On Battery	Closed if not On Battery power (Utility OK)
10	Signal Ground	Future release
11	Signal Ground	Future release
12	UPS Any-Mode Shutdown	Future release
13	Summary Alarm	Closed if no alarm conditions are present

Table 9.2 Function of UPS Vertiv Liebert IntelliSlot IS-Relay Card (continued)

Pin	Function	Operation
14	Summary Alarm	Closed if summary alarm occurs
15	Common-Summary Alarm	—
16	On UPS	Closed if On UPS (inverter) power
17	On Bypass	Closed if On Bypass
18	Common-On Bypass	—

For more information of the Vertiv™ Liebert® IntelliSlot™ IS-Relay card, refer to the **Vertiv™ Liebert® IntelliSlot™ IS-Relay Card User Manual SL-52645**.

See [Signal Cable Connection Steps](#) on page 56 for the cabling and routing of the signal cables.

9.2.3 Vertiv™ Liebert® IntelliSlot™ RDU120 Card

The Vertiv Liebert IntelliSlot RDU120 card provides Web access to UPS devices and transfers data over simple network management protocol (SNMP), Modbus, and BACNet. Environmental sensor data access is provided through Web and SNMP. The Vertiv Liebert IntelliSlot RDU120 card uses an Ethernet network to monitor and manage various operating parameters, alarms, and notifications.

Figure 9.6 below shows the appearance of the RDU120.

Figure 9.6 Vertiv Liebert IntelliSlot RDU120 Card

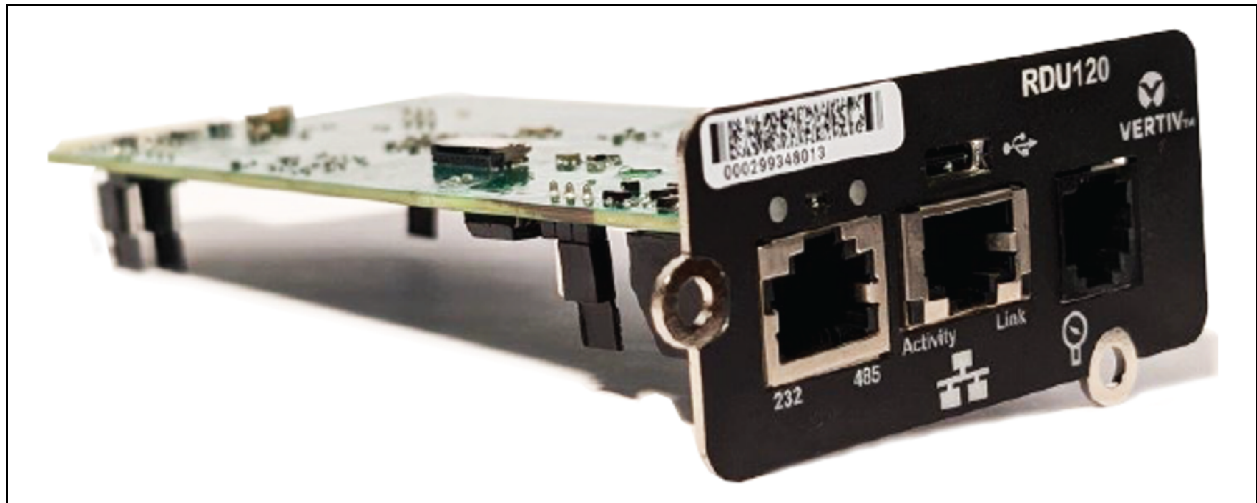

For details, refer to **Liebert® IntelliSlot™ RDU120 User Manual SL-52645**.

See the [Signal Cable Connection Steps](#) on page 56 for the cabling and routing of the signal cables.

9.2.4 Parallel Cable

Connect a module parallel cable from its PARA1 port to the PARA2 port of another module. Similarly connect other parallel cables.

Shielded and double insulated parallel cables available in lengths of 16.4 ft., 32.8 ft., and 49.2 ft. (5 m, 10 m, and 15 m) must be interconnected in a ring configuration between the UPS modules, as shown in **Figure 8.2** on page 104.

The ring connection ensures the reliability of the control of the parallel system. Verify the cable connection before starting up the UPS system.

9.2.5 Load Bus Synchronization Cable

Shielded and double-insulated parallel control cables (LBS1 and LBS2) available in lengths of 32.8 ft., 49.3 ft., and 65.7 ft. (10 m, 15 m, and 20 m). The LBS cable must be interconnected in a branch configuration between LBS1 and LBS2 of any UPS modules, as shown in **Figure 8.7** on page 110, **Figure 8.8** on page 111, and **Figure 8.9** on page 112.

9.2.6 Single Input Busbar Kit

For the UPS with single Input busbar of common input configuration, the user should select the single Input busbar Kit to short the mains input and bypass input.

9.2.7 Bypass Backfeed Protection Component (Optional)

A bypass backfeed disconnect (BFD) contactor is provided as an option. The contactor is installed inside the IO cabinet and is directly powered by the bypass input power supply. When the bypass input power is off, the contactor is disconnected. See **Figure 9.7** on the next page for the specific location.

NOTE: If the BFD option is not present, the customer must have a remote backfeed breaker (RBB) that can be controlled by a shunt trip mechanism through a programmable dry output from the UPS controls. Additionally, there is an option to include a power supply for the RBB to facilitate shunt trip control.

Figure 9.7 Bypass Backfeed Protection Component for 415 V

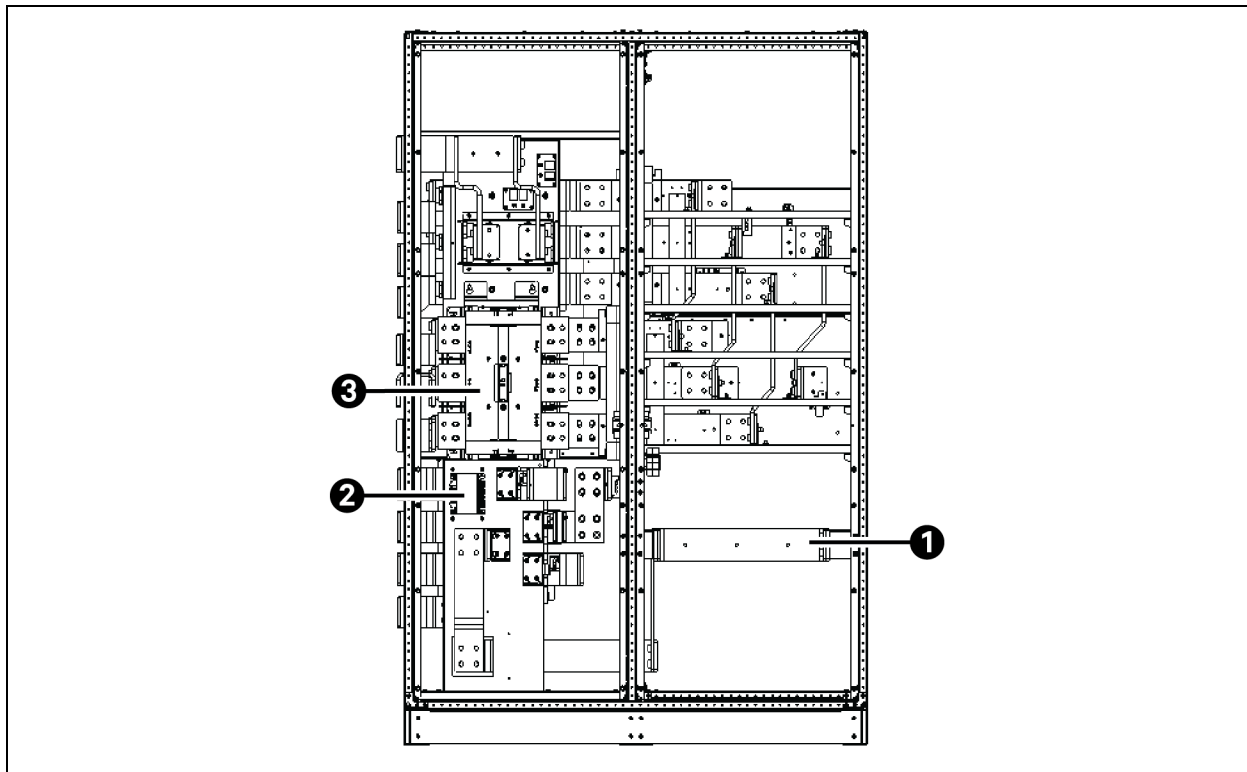

Item	Description
1	PE
2	Transformer BFD coil drive
3	BFD

10 Communication

This chapter provides information about the compatible communication protocols.

Vertiv™ PowerUPS 9000 1250 kVA 415 V Modular UPS Supports:

- SNMP Protocol communication
- Modbus protocol communication
- Dry contact communication

10.1 SNMP Protocol Communication

Vertiv™ Liebert® IntelliSlot™ RDU120 support SNMP protocol that helps to monitor the UPS through network.

IRM series sensor can also be connected to Vertiv™ Liebert® IntelliSlot™ RDU120 card to provide environmental monitoring function. When the intelligent equipment generates an alarm, the Vertiv Liebert IntelliSlot RDU120 card can notify the user by recording the log, sending trap information, and trigger mails.

The Vertiv Liebert Intellislot RDU120 card provide three approaches for you to monitor your intelligent equipment and equipment room environment:

- Using web browser. Through the Web server function provided by Vertiv Liebert Intellislot RDU120 card.
- Using network management system (NMS) through the SNMP function provided by the Vertiv Liebert Intellislot RDU120 card.

The Vertiv Liebert IntelliSlot RDU120 card shall be installed at the IntelliSlot port. See **Figure 4.7** on page 48 for more information of position of various communication card. For detailed information on installation and setup of the Vertiv Liebert Intellislot RDU120 card, refer to **Vertiv™ Liebert® IntelliSlot RDU120 Card User Manual**.

10.2 Modbus Protocol Communication

The Modbus (RTU) protocol communication is supported by the Vertiv Liebert Intellislot RDU120 card.

10.3 Dry Contact Communication

The UPS provides the following two dry contact communications:

- Vertiv™ Liebert® IntelliSlot™ IS-Relay card (Optional)
- Dry contact port of central control module

10.3.1 Communication through Vertiv™ Liebert® IntelliSlot™ IS-Relay Card

The UPS provides an Vertiv™ Liebert® IS-Relay card to use dry contact signals to monitor the UPS. For the installation and use of the Vertiv Liebert IntelliSlot IS-Relay card, refer to [Vertiv™ Liebert® IntelliSlot™ IS-Relay Card User Manual SL-26100](#).

10.3.2 Communication through Dry Contact Port of Central Control Module

For specific field needs, the UPS may need auxiliary connection to have functions such as acquiring external equipment status information, providing alarm signals to external devices, and remote EPO. These functions are realized through the following interfaces on the central control module:

- Input dry contact port status information.
- Output dry contact ports of alarm signal.
- EPO input port.

For the functions and detailed information of these ports, see [Wiring of Signal Cable](#) on page 48.

11 Service and Maintenance

The UPS system (including the battery) requires periodic service and maintenance to ensure long service life. This chapter provides information about the service life, regular inspection, maintenance, and replacement of the key UPS components.

NOTE: Effective maintenance of the UPS system can reduce the risk of UPS failure and will increase the UPS service life.

11.1 Safety for Service and Maintenance



WARNING! Replacement, service, and maintenance is to be performed only by authorized Vertiv personnel to prevent device malfunction.



AVERTISSEMENT! Le remplacement, le service et l'entretien doivent être effectués uniquement par du personnel Vertiv autorisé afin de prévenir tout dysfonctionnement de l'appareil.



WARNING! The neutral line has hazardous voltage. When servicing the UPS, use caution to prevent accidental injury or death. Use personal protective equipment.



AVERTISSEMENT! La ligne neutre présente une tension dangereuse. Lors de l'entretien de l'onduleur, faites preuve de prudence pour éviter tout accident ou décès. Utilisez des équipements de protection individuelle.



WARNING! If the USP does not have a switch or if it has 3 switches, switch off the disconnect device before maintenance, and check whether the UPS is powered on.



AVERTISSEMENT! Si l'USP n'a pas d'interrupteur ou s'il en a 3, éteignez le dispositif de déconnexion avant l'entretien et vérifiez si l'UPS est sous tension.



WARNING! The components that can only be accessed by opening the protective cover with tools cannot be operated by the user. Only qualified service personnel are authorized to remove such covers.



AVERTISSEMENT! Les composants qui ne peuvent être accessibles qu'en ouvrant le couvercle de protection avec des outils ne peuvent pas être manipulés par l'utilisateur. Seul le personnel de service qualifié est autorisé à retirer ces couvercles.

11.2 Service Procedures of Power Module and Bypass Power Module

NOTE: Only Vertiv service engineers are to service power modules and bypass power modules.

To service the power modules and bypass power modules, perform the following steps:

1. Remove the power modules and bypass power module from top to bottom to prevent cabinet toppling due to high gravity center.
2. Do not disassemble the power module, bypass power module, and central control module. They may have high voltage inside.
3. Service the power modules and bypass power modules after 5 minutes of unplugging from power source.
4. Put the modules back into the cabinet after 5 minutes after servicing.
5. Do not pull different types of modules out of the cabinet at the same time.

11.3 Key Components and Service Life of UPS

When in use, some components of UPS system will have shorter service life compared to the UPS due to abrasion. For the safety of the UPS supply system, it is necessary to have regular inspection and replacement of these components. This section introduces the key components of UPS and the reference years of service life. For systems under different conditions (environment or load rate) assessment and advice by service engineers on whether to replace the device are required with reference to the information provided in this section.

11.3.1 Life Parameters and the Proposed Replacement Time of Key Components

Key components in **Table 11.1** below are used in the UPS system. To prevent system failures due to some device failure by wear, it execute the regular inspection and replacement during its estimated life.

Table 11.1 Life Parameters and the Recommended Replacement Time of Key Components

Key Components	Estimated Life	Proposed Replacement Time	Proposed Inspection Period
Fan (AC/DC)	Not less than 7 years	5 years to 6 years	1 year
Air filter	1 year to 3 years	1 year to 2 years	2 months

11.3.2 Replacement of Air Filter

NOTE: The air filters need regular inspection and replacement, which depends on the environmental conditions of the UPS. Under normal environmental conditions, the air filters should be cleaned or replaced once every two months and need more frequent cleaning and replacement in dusty or other unclean environments.

The UPS has air filters mounted on the rear side of the front door of the cabinet. The filters can be replaced while the UPS is operational.

The air filters are fixed by bars on both sides. See **Figure 11.1** below for location of filter.

To replace the air filters:

1. Open the front door of the UPS.
2. Loosen the screws to remove fixing bars.
3. Replace the clean air filter.
4. Reinstall the fixing bar and tighten all the fixing screws.

Figure 11.1 Replacing Air Filter

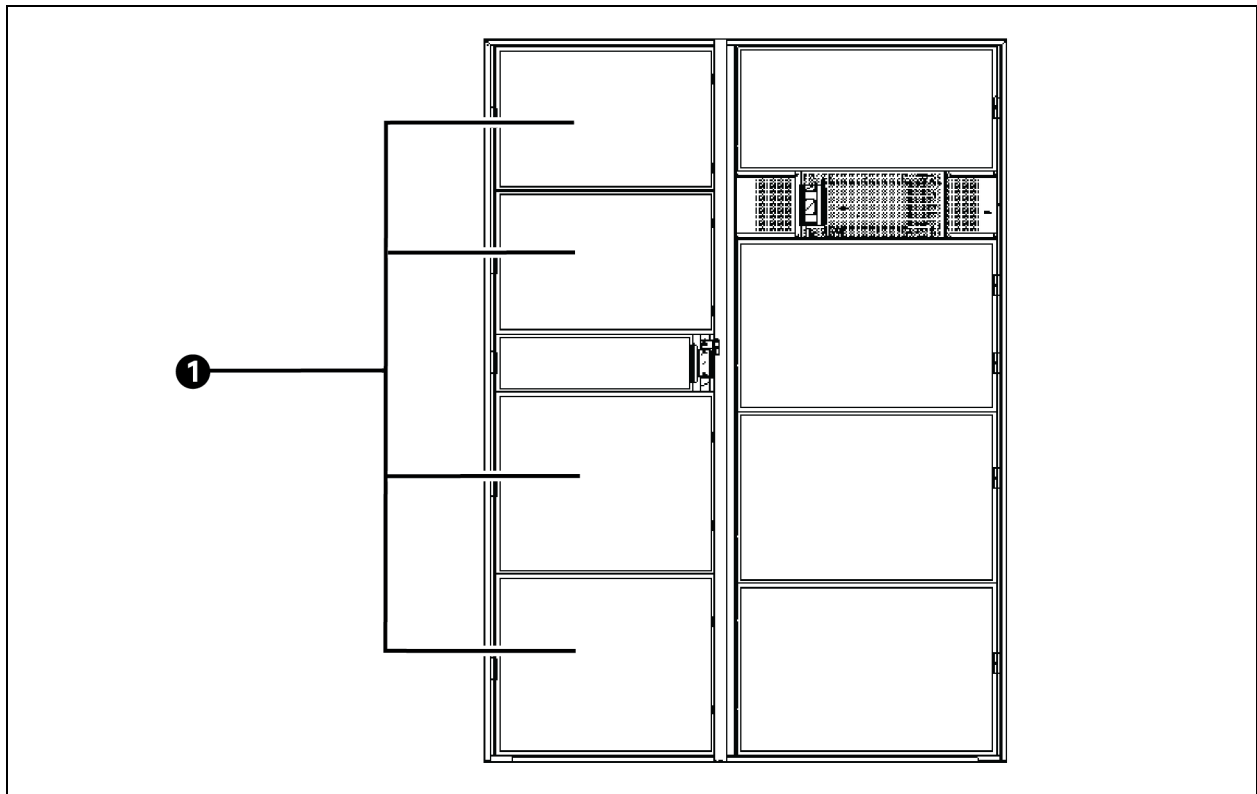

Item	Description
1	Air filter

11.4 Maintenance of UPS and Options

UPS and the options need common maintenance:

1. Keep good maintenance records. Keeping good maintenance records facilitates failure treatment.
2. Keep the surrounding environment clean to prevent dust and moisture entering the UPS.
3. Maintain an ambient temperature of 68 °F to 77 °F (20 °C to 25 °C) for the battery.

NOTE: Very low temperature will reduce the battery capacity and if it is too high the battery life will reduce.

4. Check all wiring regularly for damage.
5. Check and tighten all the accessible screws, at least once a year.
6. Check regularly for any abnormality in the upstream or downstream switch to maintain reliability when cutting off the input or output when the current is too large.
7. Regularly check the status of the LED light on the built in lightning protection board of the UPS. If the indicator light is abnormally off, replace the lightning protection board. See Power switch for the position of the lightning protection board.

Maintenance staff should be familiar with the typical ambient conditions in which the UPS operates, so they can quickly identify any abnormal conditions. All maintenance staff should also be familiar with the settings on the UPS touchscreen.

12 Specifications

This chapter includes all the required UPS specifications.

12.1 Conformance and Standards

The Vertiv™ PowerUPS 9000 1250 kVA 415 V Modular UPS has been designed to conform to the following standards:

- Safety UL 1778, 5th Edition, CSA 22.2 107.3-14.
- FCC PART 15-RADIO FREQUENCY DEVICES, Subpart B, CLASS A.
- Transportation ISTA 3B
- ISO 9001
- ICC-ES AC156
- OSHPD
- UL 9540 (when paired with selected Vertiv battery switch)

The Vertiv PowerUPS 9000 1250 kVA 415 V Modular UPS has cULus approval.

The Vertiv PowerUPS 9000 1250 kVA 415 V Modular UPS suitable for computer-room applications, ANSI/NFPA 75.

The Vertiv PowerUPS 9000 1250 kVA 415 V Modular UPS is ENERGY STAR certified satisfying ENERGY STAR Program Requirements Product Specification for UPS - Eligibility Criteria, Version 2.0.

12.2 Environmental Characteristics

Table 12.1 Environmental Characteristics

Item	Normative Reference	Rated Power (kVA)
		1250 kVA 415 V
Noise within 3.3 ft. (1 m) (in the front)	dB (A)	<79 dB at 100% load
Altitude	m	≤ 3000; derate power by 1% per 100 m between 1500 m and 3000 m
Relative humidity	%RH	0 to 95%, non-condensing
Operating temperature	°C	0 to 40, at full load; 41 to 45, 90% load; 46 to 50, 80% load
Storage and transportation temperature for UPS	°F (°C)	Storage: -13 °F to 131 °F (-25 °C to +55 °C), Transportation: -40 °F to 158 °F (-40 °C to +70 °C)
Pollution level		Level 2
Grid system		TN, TT, IT, TN-S

12.3 Mechanical Characteristics

Table 12.2 Mechanical Characteristics

Item		Unit	Rated Power (kVA)
			1250 kVA 415 V
Power module Dimensions (W × D × H)	Packing excluded	in. (mm)	22.9 × 27.5 × 5.2 (580 × 698 × 130)
	Packing included	in. (mm)	31.3 × 38.8 × 13.78 (795 × 985 × 350)
Power module	Net weight	lbs (kg)	143.3 (65)
	Gross weight	lbs (kg)	150 (68)
System Dimensions (W × D × H)	Packing excluded	in. (mm)	106.3 × 39.37 × 78.74 (2700 × 1000 × 2000)
	Packing included	in. (mm)	111.4 × 46.46 × 87.8 (2830 × 1180 × 2230)
	Net weight (not include power module)	lbs (kg)	3165.8 (1436)
	Gross weight (not include power module)	lbs (kg)	3439.2 (1560)
Color		ZP7021	
Protection degree, IEC (60529)		IP20 (front door open or closed)	

12.4 Electrical Characteristics (Input Rectifier)

Table 12.3 Rectifier AC Input (Mains)

Parameter	Unit	Rated Power (kVA)
		1250 kVA 415 V
Rated AC input voltage	VAC	415 4-wire (3-phase +N+PE)
Operation line voltage	VAC	228 V to 478 V (132 V to 276 V).
Input voltage range	VAC	332 V to 476 V (192 V to 276 V) at 100% load, 228 V to 332 V (132 V to 192 V) with linear derating.
Frequency	Hz	50/60 (range: 40 to 70)
Power factor	kW/kVA, full load (half load)	0.99
Input current	A, rated ³	1805
Total current harmonic distortion (at full load)	%	3

1. Rectifiers operate at any of the rated supply voltages and frequencies without further adjustment.
2. At 305V input mains the UPS maintains the specified output voltage at rated load without discharging a battery.
3. At rated load, input voltage is 415 V, battery remains fully charged.

12.5 Electrical Characteristics (Battery Bus)

Table 12.4 Battery

Item	Unit	Rated Power (kVA)
		1250 kVA 415 V
Maximum charging current	A	550 (55 amps per power module)
Quantity of lead-acid cells (nominal)	Block	30 to 50 jars with derating 40 to 50 jars without derating
Float voltage	V/cell (VRLA)	2.27 (selectable from 2.20 V/cell to 2.30 V/cell) Constant current and constant voltage charge mode
	V/cell (Ni-Cd)	1.45 (selectable from 1.35 V/cell to 1.45 V/cell) Constant current and constant voltage charge mode
	V/cell (Li-ion)	4.2 (selectable from 4.0 V/cell to 4.2 V/cell) for LiMn ₂ O ₄ . 3.45 (selectable from 3.4 V/cell to 3.65 V/cell) for LiFePO ₄ . 4.14 (selectable from 4 V/cell to 4.2 V/cell) for ternary battery. 2.6 (selectable from 2.55V/cell to 2.7 V/cell) for LTO.
Temperature compensation	mV/°C/cl	-3.0 (selectable from 0 to -5.0 around the central point preset in paramset)
Ripple current	% C10	≤5
Boost voltage	V/cell (VRLA)	2.35 (selectable from 2.30 to 2.40 Constant current and constant voltage charge mode)
	V/cell (Ni-Cd)	1.5 (selectable from 1.45 to 1.5). Constant current and constant voltage charge mode
	V/cell (Li-ion)	3.48 (selectable from 3.45 to 3.65) for LiFePO ₄ . Other types are forced to be equal to the float voltage.
Boost control		Float-boost current trigger 0.050C10 (selectable from 0.001 to 0.070) Boost-float current trigger 0.010C10 (selectable from 0.001 to 0.025) 8 hours safety time timeout (selectable from 8 hours to 100 hours) Boost mode inhibit also selectable
EOD voltage	V/cell (VRLA)	EOD Lower Voltage: 1.60 VDC to 1.67 VDC, 1.63 VDC default for lead acid battery. EOD Upper Voltage: 1.67 VDC to 1.85 VDC, 1.75 VDC default for lead acid battery.
	V/cell (Ni-Cd)	EOD Lower Voltage: 0.9 VDC to 1.0 VDC, 1.0 VDC default for Ni-Cd battery. EOD Upper Voltage: 1.0 VDC to 1.1 VDC, 1.0 VDC default for Ni-Cd battery.
	V/cell (Li-ion)	EOD Lower Voltage: 2.9 VDC to 3.4 VDC, 3.15 VDC default for LiMn ₂ O ₄ battery. EOD Upper Voltage: 2.9 VDC to 3.4 VDC, 3.3 VDC default for LiMn ₂ O ₄ battery. EOD Voltage: 2.5 VDC to 2.9 VDC, 2.85 VDC default for LiFePO ₄ battery. EOD Voltage: 2.9 VDC to 3.4 VDC, 2.9 VDC default for ternary battery. EOD Lower Voltage: 1.8 VDC to 2.05 VDC, 1.9 VDC default for LTO battery. EOD Upper Voltage: 1.8 VDC to 2.05 VDC, 2.0 VDC default for LTO battery.

12.6 Electrical Characteristics (Inverter Output)

Table 12.5 Inverter Output (to Critical Load)

Item	Unit	Rated Power (kVA)
		1250 kVA 415 V
Rated AC voltage	VAC	415 4-wire (3-phase +N+PE)
Frequency	Hz	50/60
Power factor		0.99
Overload	%	<105, continuous <125, ≤10 minute <150, ≤1 minute >150, ≤200 millisecond
Maximum short circuit current of inverter	A	180% rated output current, 200 millisecond
Steady state voltage stability	%	±1
Transient voltage response	%	±5
Total voltage harmonic distortion	%	<1 (linear load), <3 (non-linear load) <1 (linear load), <3 (non-linear load)
Synchronization window	Hz	Upper Limit: 0.5, 1, 2, 3, (+10%); Default: +10%. Lower Limit: -0.5, -1, -2, -3, (-10%); Default: -10%
Slew rate (maximum change rate of synchronization frequency)	Hz/s	0.6; setting range: 0.1 to 3

12.7 Electrical Characteristics (Bypass Input)

Table 12.6 Bypass Input

Item	Unit	Rated Power (kVA)
		1250 kVA 415 V
Rated AC voltage	VAC	415 4-wire (3-phase +N+PE)
Rated current	A	1504
Frequency	Hz	50/60
Bypass voltage tolerance	%VAC	<p>Normal Mode: The bypass synchronized voltage range is decided by the bypass qualified</p> <p style="text-align: center;">Voltage range: -15% to +10% for 415 V models.</p> <p>ECO Mode: The bypass synchronized voltage range is configurable:</p> <p style="text-align: center;">Upper limit selections: +5%, +10%, +15%; default +5%.</p> <p style="text-align: center;">Lower limit selections: -5%, -10%, -15%; default -5%.</p> <p>Dynamic Online Mode: The bypass synchronized voltage range is configurable:</p> <p style="text-align: center;">Upper limit selections: +5%, +10%; default +5%.</p> <p style="text-align: center;">Lower limit selections: -5%, -10%; default -5%.</p>
Bypass frequency tolerance	%	±10
Bypass SCR I ² T	A ² S	6480000
Bypass KAIC fuse I ² T	kA ² S	2000 (pre arc). 13500 (clearing)
Bypass Withstand Rating		150 kAIC

12.8 Efficiency and Loss

Table 12.7 Efficiency and Loss

Item	Unit	Rated Power (kVA)
		1250 kVA 415 V
Rated normal mode (full load) loss	kW	43.86
Rated normal mode (no load) loss	kW	4.25
ECO mode (full load) loss	kW	12.75
Dual conversion mode efficiency	%	up to 97.5±0.2
ECO mode efficiency	%	up to 99

This page intentionally left blank

Appendices

Appendix A: Technical Support and Contacts

A.1 Technical Support/Service in the United States

Vertiv Group Corporation

24x7 dispatch of technicians for all products.

1-800-543-2378

Liebert® AC and DC Power Products

1-800-543-2378

A.2 Locations

Vertiv Americas Headquarters

Vertiv Headquarters

Westerville, OH 43082

Vertiv EMEA Headquarters

Victor-von-Bruns Strasse 21,

8212 Neuhausen am Rheinfall, Switzerland

Vertiv Asia Headquarters

Singapore Location

151 Lorong Chuan, Lobby D #05-04

New Tech Park, Singapore 556741

India Location

Vertiv Energy Private Limited,

Plot No. C 20, Road No. 19, Wagle Industrial Estate, MIDC,

Thane (West), Maharashtra 400604, India

China Location

Vertiv Technology Co., Limited

Floors 1–4 and 6–10,

Building B2, Nanshan I Park, No. 1001 Xueyuan Road, Nanshan District

Shenzhen, Guangdong 518055, China

Appendix B: Glossary

Term	Definition
AC	Alternating current
BCB	Battery circuit breaker
BFD	Backfeed disconnect
BIB	Bypass isolation breaker
CSA	Cross sectional area
DC	Direct current
DSP	Digital signal processor
ECO	Economic control operation
EIB	External interface board
EMC	Electromagnetic compatibility
EMI	Electromagnetic interference
EOD	End of discharge
EPO	Emergency power off
FPGA	Field programmable gate array
GFD	Ground fault detector
GND	Ground
GHMI	Global human machine interface
HMI	Human machine interface
I/O	Input/output
IGBT	Integrated gate bipolar transistor KAIC Kilo ampere interrupting capacity
KAIC	Kilo ampere interrupting capacity
LBS	Load bus synchronizer
LCD	Liquid crystal display
LED	Light-emitting diode
LLBB	Local Load Bank Breaker
LOTO	Lock out tag out
MBB	Maintenance bypass breaker
MCCB	Molded Case Circuit Breaker
MIB	Maintenance isolation breaker
MOB	Module Output Breaker
PC	Personal computer

Term	Definition
PE	Protective earth
RBB	Remote Bypass Breaker
RCCB	Residual current circuit breaker
RCD	Residual current detector
RFB	Remote feed breaker
REPO	Remote emergency power off
SCR	Silicon-controlled rectifier
SLBB	System Load Bank Breaker
SNMP	Simple network monitoring protocol
SOR	Shunt Open Release
SSIB	Static Switch Isolation Breaker
STS	Static transfer switch
SVPWM	Space vector pulse width modulation
UPS	Uninterruptible power system
UVR	Under Voltage Release
VRLA	Valve regulated lead-acid

Appendix C: Hazardous Substances and Content

Parts	Hazardous Substances					
	Plumbum	Mercury	Cadmium	Chrome ⁶⁺	Polybrominated Biphenyls	Polybrominated Diphenyl Ethers
	(Pb)	(Hg)	(Cd)	Cr (VI)	(PBB)	(PBDE)
Hex copper stud	x	○	○	○	○	○
PCBA	x	○	○	○	○	○
AC Capacitor	x	○	○	○	○	○
DC Capacitor	x	○	○	○	○	○
Fan	x	○	○	○	○	○
Cables	x	○	○	○	○	○
LCD	x	x	○	○	○	○
Sensors	x	○	○	○	○	○
Large-medium power magnetic components	x	○	○	○	○	○
Circuit breaker/rotating switch	x	○	○	○	○	○
Semiconductors	x	○	○	○	○	○
Battery (if applicable)	x	○	○	○	○	○
Insulation monitoring device (if applicable)	x	○	○	○	○	x
<p>NOTE: This table is prepared based on the regulation of SJ/T 11364.</p> <p>Content of the hazardous substances in all the average quality materials of the parts is within:</p> <p>○: The specified limits.</p> <p>x: Outsides specified the limits.</p> <p>About battery: Generally follow the environmental protection use period of the battery, otherwise five years.</p> <p>The Hazardous Substances and Content mentioned are applicable to Vertiv™ PowerUPS 9000 1250 kVA 415 V Modular UPS.</p>						

Connect with Vertiv on Social Media



<https://www.facebook.com/vertiv/>



<https://www.instagram.com/vertiv/>



<https://www.linkedin.com/company/vertiv/>



<https://www.x.com/Vertiv/>



Vertiv.com | Vertiv Headquarters, 505 N Cleveland Ave, Westerville, OH 43082 USA

©2026 Vertiv Group Corp. All rights reserved. Vertiv™ and the Vertiv logo are trademarks or registered trademarks of Vertiv Group Corp. All other names and logos referred to are trade names, trademarks or registered trademarks of their respective owners. While every precaution has been taken to ensure accuracy and completeness here, Vertiv Group Corp. assumes no responsibility, and disclaims all liability, for damages resulting from use of this information or for any errors or omissions.

SL-80202_REVC_04-26