

Introduction

This interface connection guidance manual is designed to assist in the safe handling and installation of the Vertiv Switchgear input/output (I/O) box and Vertiv™ Trinergy™ UPS system. These instructions are in addition to normal safe working practices as required by local health and safety regulations and statutory authority of the location of the installation. These instructions do not advocate a departure from these requirements.

NOTE: There will be 3-wire and 4-wire versions depending on where product is being deployed. Only 4-wire version is referred to in this document.

Vertiv™ PowerNexus Layout

The design and the layout of the UPS system and associated panels and cabling should be examined closely to ensure that cable lengths and impedance are closely matched. The PowerNexus system combines the Switchgear I/O box and Vertiv Trinergy UPS.

Figure 1 Example of Back-to-Back Layout

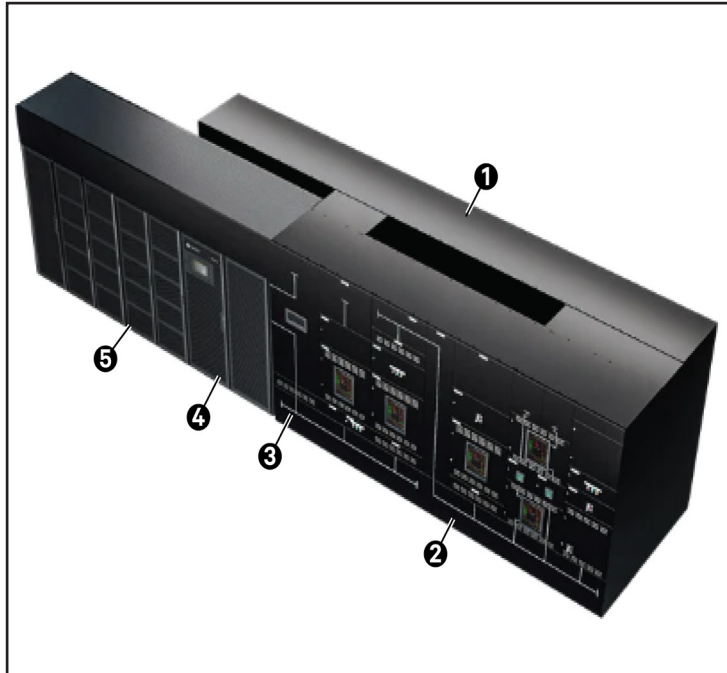

Item	Description
1	Low voltage (LV) Switchgear
2	LV Switchgear including I/O box
3	I/O box
4	Static transfer switch (STS)
5	Vertiv Trinergy UPS including STS

Figure 2 Example of Front-to-Front Layout

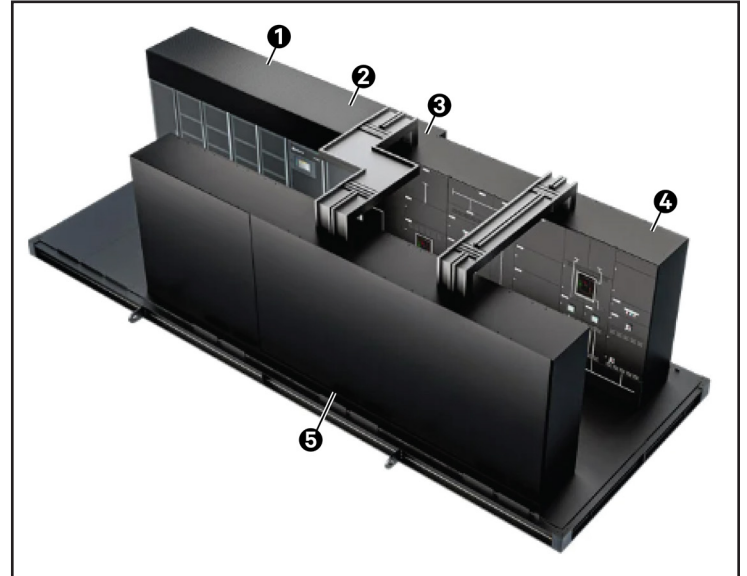

Item	Description
1	Vertiv Trinergy UPS including STS
2	STS
3	I/O box
4	LV Switchgear including I/O box
5	LV Switchgear

Figure 3 I/O Box - Back-to-Back

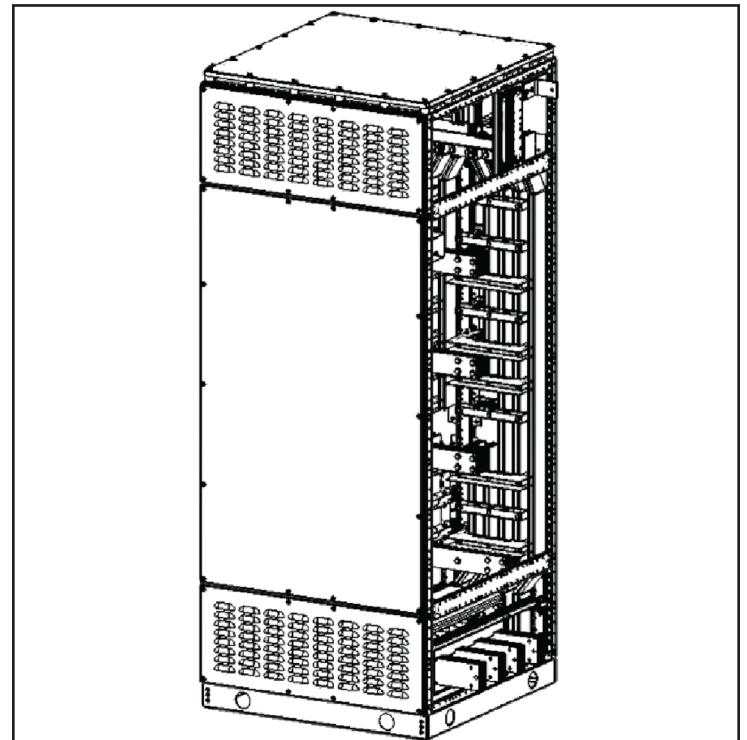

Figure 4 I/O Box - Front-to-Front

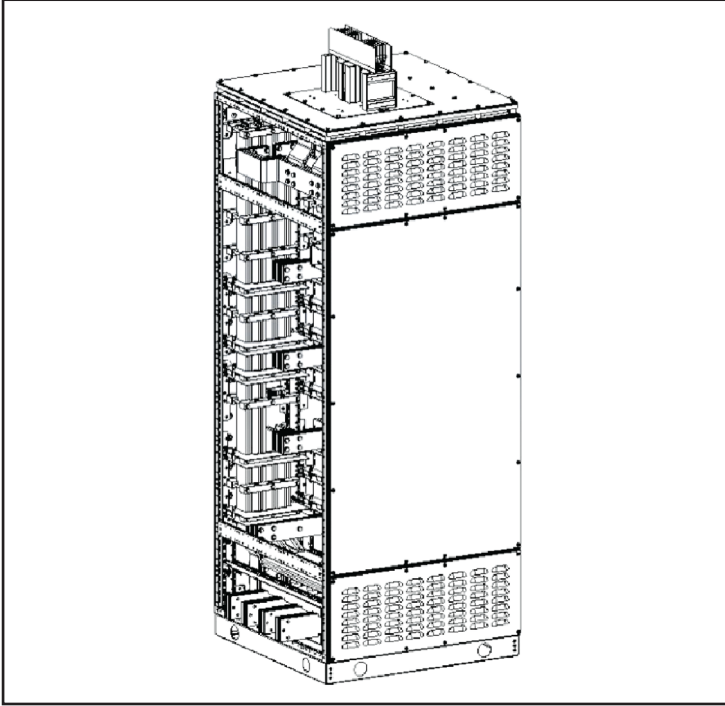
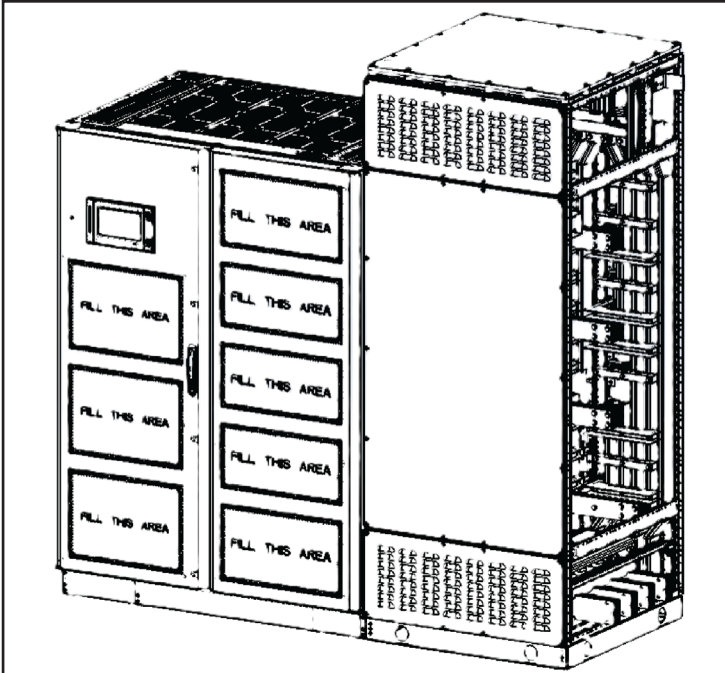

Figure 5 Coupling of I/O Box and UPS/STS



Installation of Vertiv Switchgear I/O Box

Switchgear and UPS will be positioned by the integration team in line with the integrators project specific logistics plan.

Factors to be considered within the logistics plan of integrator:

- Provide access to the rear sides of the UPS and Switchgear in line with their respective install manuals. Plan the installation sequence so that one equipment does not block the other equipment.

- Consider the size and weight of the equipment during installation. Set up the equipment such that it will be easy to adjust its position after installation. Switchgear sizes and weights will depend on the specific project.
- Additional installation space is required. For example, if busbar from one Switchgear section will ultimately extend into a neighboring Switchboard section, additional space is needed temporarily to allow one to pass the other before being joined. The minimum requirement space is 8 in. (200 mm).

Figure 6 Overlapping Copper. Gap required for installation



- As equipment is installed in order, use the Switchgear reconnection and test manual to guide competent technicians in reconnecting and testing the system.
- Testing procedure with specific reference to the I/O box:

- All other Switchgear is mechanically and electrically reconnected.

NOTE: The Switchgear I/O box busbar must not be connected to the Vertiv™ Trinergy™ UPS/STS busbar.

- Switchgear will be tested by trained/competent persons in line with normal Switchgear testing procedures as outlined by the project specific testing documentation.

NOTE: The Switchgear I/O busbar can only be connected to the UPS busbar after all electrical testing on both the UPS and Switchgear systems is complete.

- Connection of the I/O box to the UPS/STS (the interface):
 - Scope of supply (loose items)

Loose Items	
AC Power (UPS/STS)	Switchgear (I/O Box)
Frame fixing screws	Series of Packers: <ul style="list-style-type: none"> • Quantity-20 of 80x80 10 mm packers (quantity-18 for 3-wire) • Quantity-20 of 80x80 6 mm packers (quantity-18 for 3-wire)
L-shaped coppers complete with clenched nut (these will be fitted to the UPS/STS prior to integration)	Bolts: Quantity-40 of M10 x 130 mm bolt and washers (quantity-36 for 3-wire)
	Drawing detail showing combination of Packers for each joint (refer to appended drawings)
	Busbar trunking flange (if it was removed for shipping) + fixings

- Prior to the I/O box and UPS/STS coming together, the gasket is fitted to the left side of the I/O box in line with the Switchgear reconnection and test manual.
- The equipment is aligned and leveled as necessary to ensure both sets of busbar can be connected without additional pressure being exerted on the joint. Frame fixing holes must be aligned.
- The UPS/STS copper will pass through slots in the side of the I/O box. Refer to install drawings. Maintain clearance between the copper parts and the slots.

Figure 7 I/O Box Interface Connections

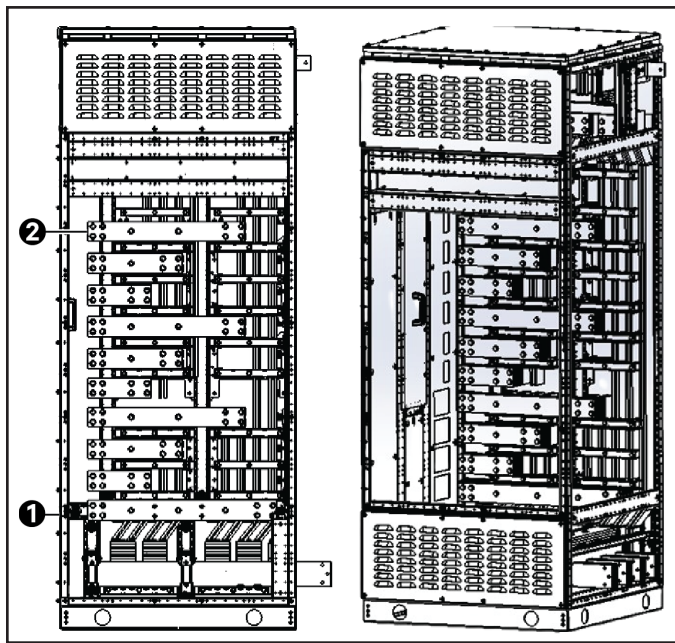

Item	Description
1	Frame fixing points (refer to drawing)
2	Busbar interface connections (quantity-10)

- Join the frames using frame fixing screws.
- Fit the packers and bolts as shown in the Figure 9. Tighten the bolts to the correct level. Tighten the M10 bolts to a torque of 354 lb-in (40 Nm) ±20% torque. Follow AC power's recommendation for the clenched nut already fitted to the L-copper. (For more information about Figure 3 through Figure 12 refer to the details drawing in the appendix.)

Figure 8 Side View of I/O Box

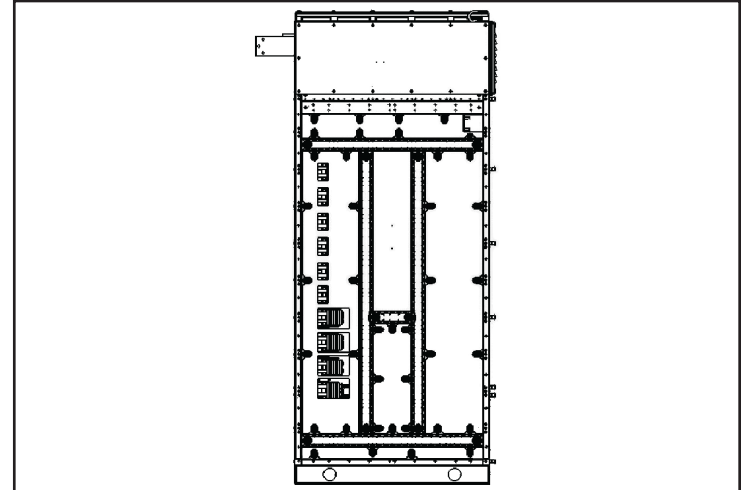
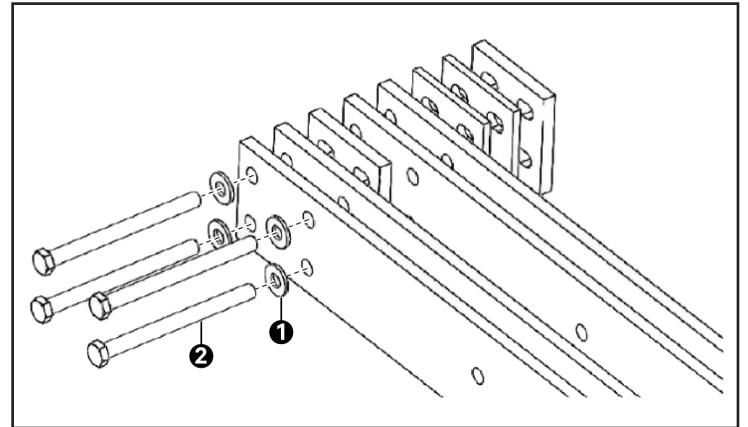

Figure 9 Exploded View of Busbar/Packer/Bolt Arrangement



Item	Description	Item	Description
1	Washer	2	Bolt

- Testing and documentation:
 - A contact resistance test (also known as a ductor test) will be carried out across the connected joints. Results will be recorded and added to the project test documentation.
 - Operative record of torque procedures having been followed (torque verification).
- Cable routing facility for Control and/or communication cables is included as part of the I/O box design. This is located at the top front, behind the cover. This will be utilized to route cables from UPS to some other part of the Vertiv Switchgear or vice versa.

Figure 10 Height of Connecting Busbar from Datum Points

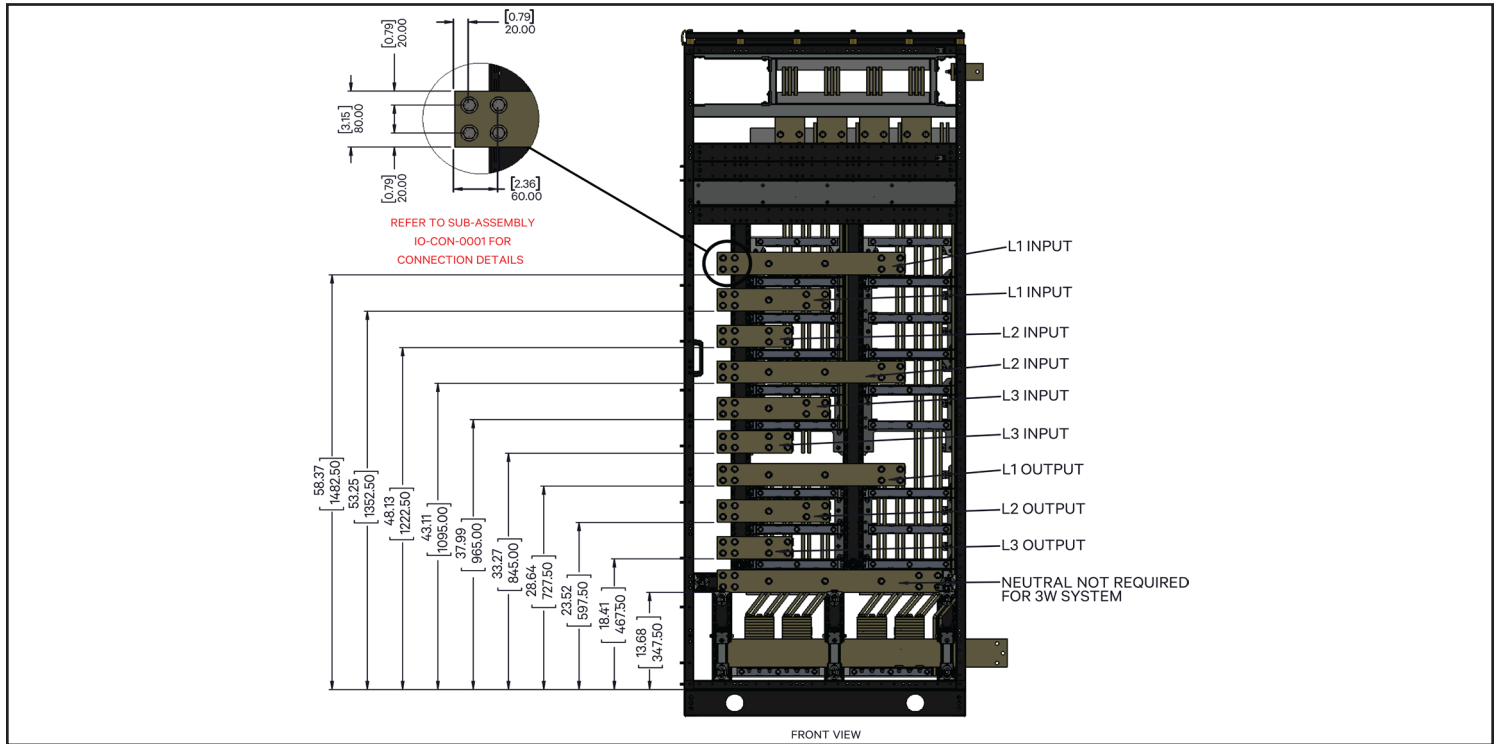

Figure 11 L-shaped Copper Busbar in Segregation Slots

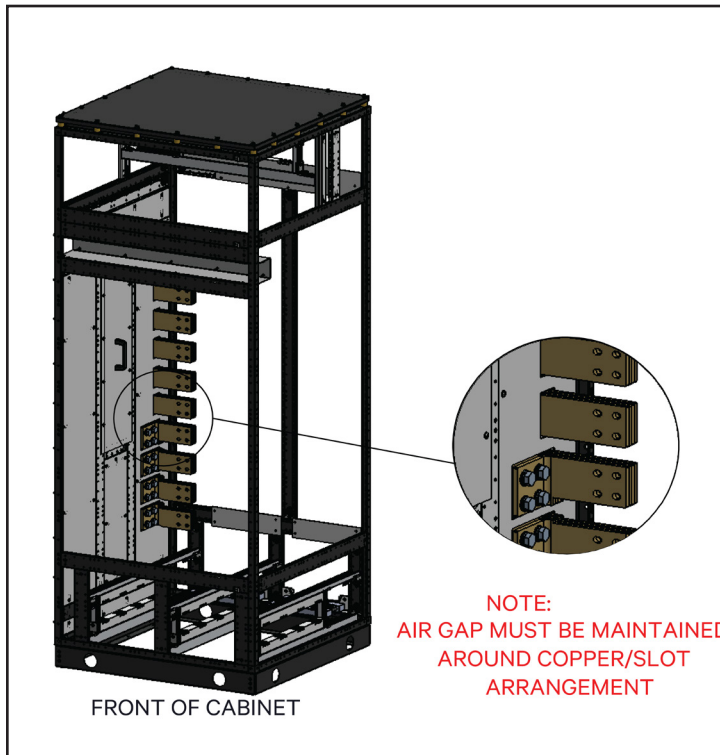
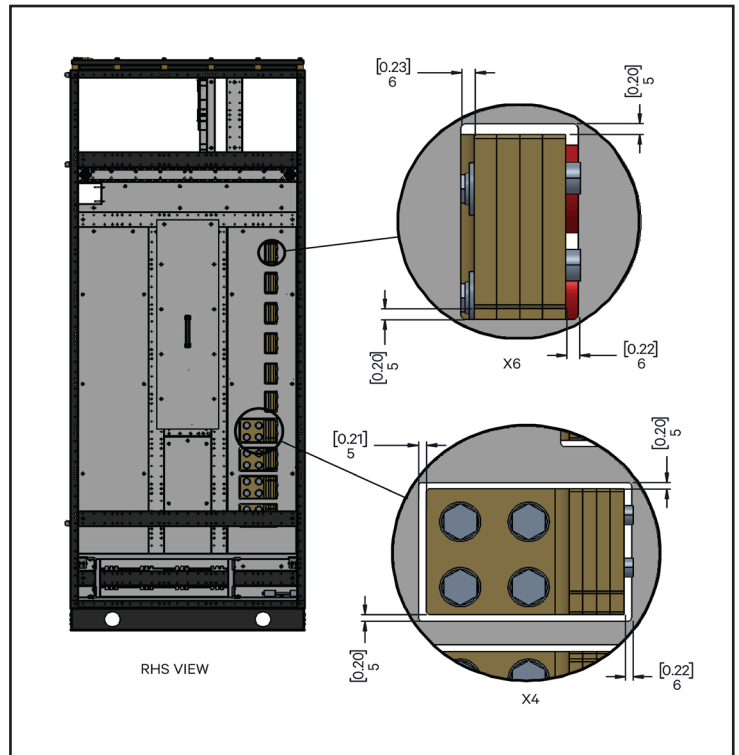

Figure 12 Clearance of Segregation Slots



To contact Vertiv Technical Support: visit www.Vertiv.com

© 2026 Vertiv Group Corp. All rights reserved. Vertiv™ and the Vertiv logo are trademarks or registered trademarks of Vertiv Group Corp. All other names and logos referred to are trade names, trademarks or registered trademarks of their respective owners. While every precaution has been taken to ensure accuracy and completeness here, Vertiv Group Corp. assumes no responsibility, and disclaims all liability, for damages resulting from use of this information or for any errors or omissions.



CO NO	REV	DESCRIPTION	DRAWN BY:	DATE
			APPROVED BY:	DATE

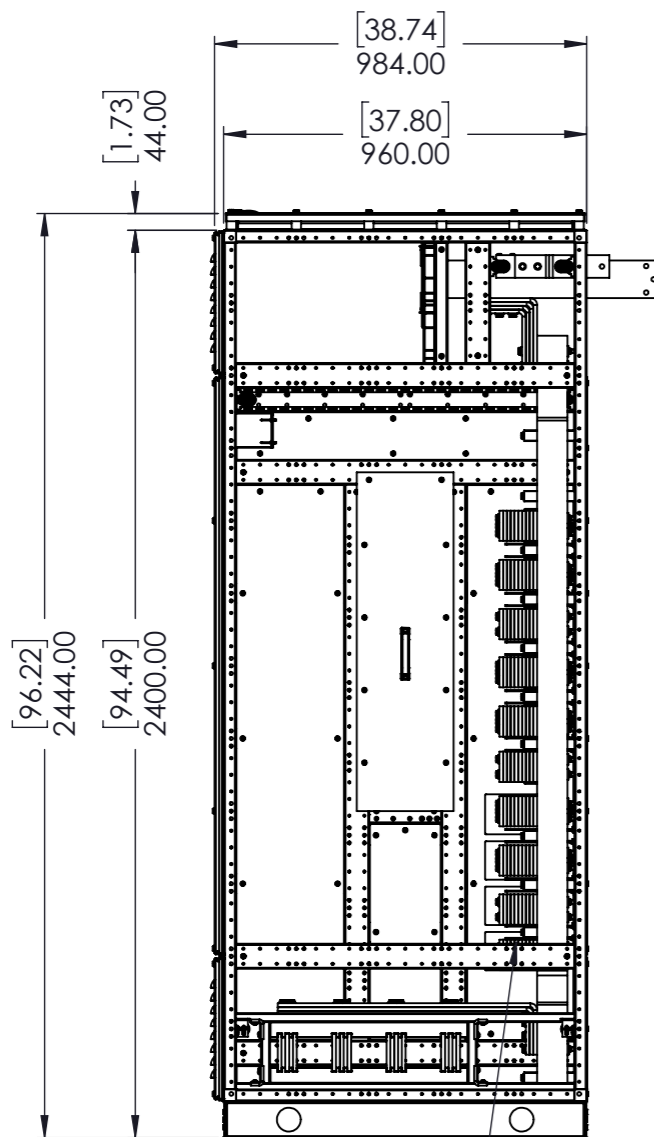

RHS VIEW

NEUTRAL NOT REQUIRED FOR 3W SYSTEM

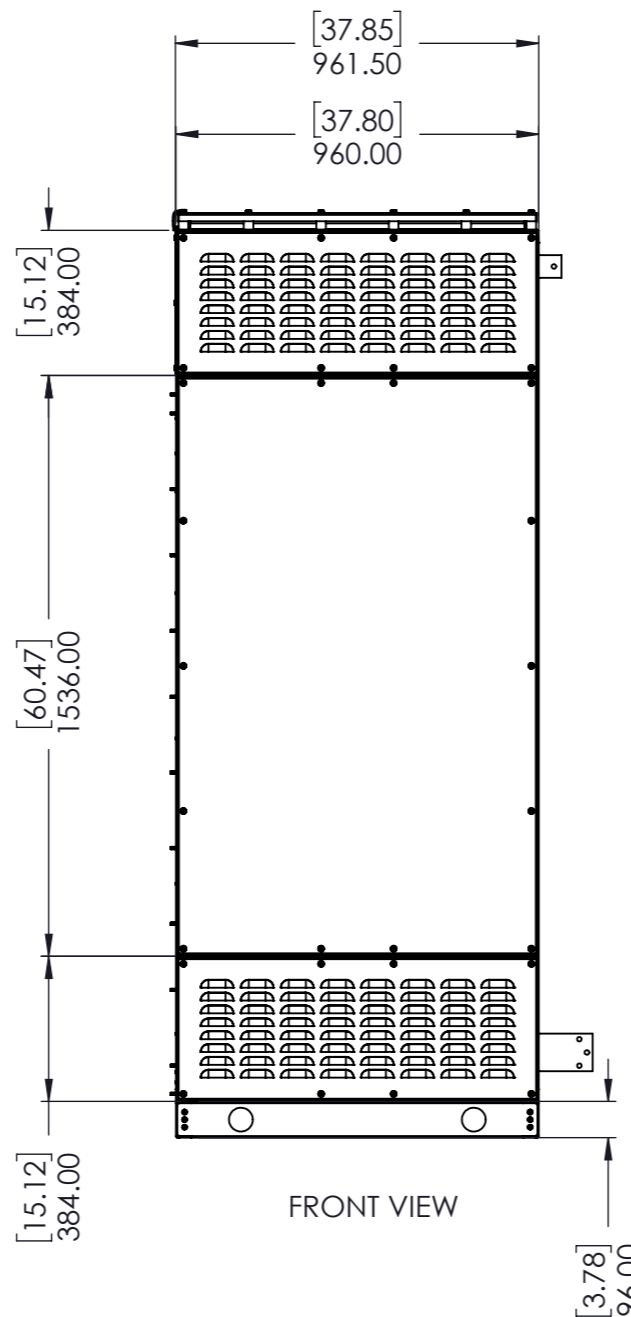

FRONT VIEW

NEUTRAL NOT REQUIRED FOR 3W SYSTEM

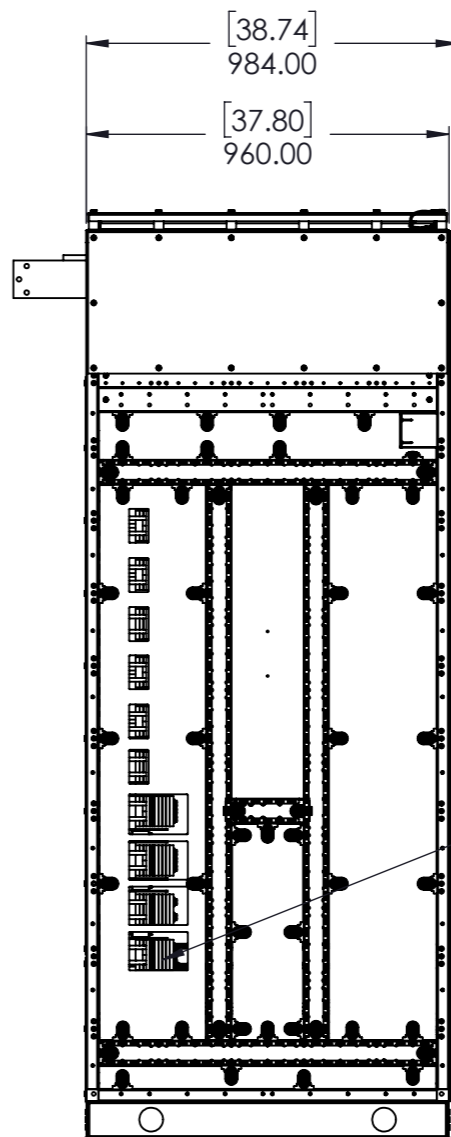

LHS VIEW

NEUTRAL NOT REQUIRED FOR 3W SYSTEM

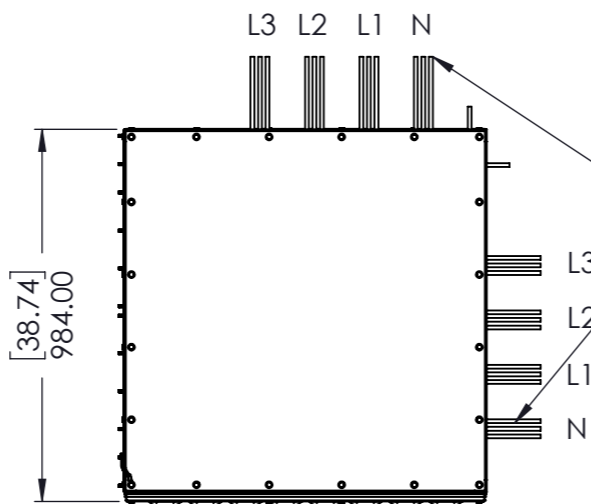

PLAN VIEW

NOTES:

- CONSTRUCTION MATERIAL: 2MM THICK POWDER COATED MILD STEEL
- ALL DIMENSIONS IN MILLIMETERS/INCHES
- PROTECTION IEC: IP31
UL: TYPE 1
- ACCESS: FRONT
- BUSBARS ARE DESIGNED FOR A SHORT-CIRCUIT WITHSTAND STRENGTH IEC: 100% (100kA/1SEC)
UL: 3c cycles @ 100kA
- COPPER COULD BE BARE OR TINNED

I	CORPORATE CAGE CODE	505 N. CLEVELAND AVE WESTERVILLE, OHIO 43082	IO CABINET BACK TO BACK	DIMENSION DRAWING
	1EDC2		PART NUMBER	DESCRIPTION
<small>© 2018 VERTIV CO. CONFIDENTIAL AND PROPRIETARY. ALL RIGHTS RESERVED. VERTIV AND THE VERTIV LOGO ARE TRADEMARKS OR REGISTERED TRADEMARKS OF VERTIV CO. THIS DOCUMENT AND THE INFORMATION IT CONTAINS ARE THE PROPERTY OF VERTIV CO. BY ACCEPTING IT INTO YOUR POSSESSION, YOU AGREE THAT YOU WILL KEEP THIS DOCUMENT AND ALL INFORMATION CONTAINED HEREIN IN STRICTEST CONFIDENCE AND WILL NOT COPY, RE TRANSMIT, USE (EXCEPT SOLELY FOR THE BENEFIT OF VERTIV CO.), SELL, LEND, OR OTHERWISE DISPOSE OF SAME, DIRECTLY OR INDIRECTLY, WITHOUT THE EXPRESS WRITTEN PERMISSION OF VERTIV CO., AND THIS DOCUMENT SHALL BE RETURNED TO VERTIV CO. IMMEDIATELY UPON REQUEST.</small>				
MATERIAL:		THICKNESS(mm)	UNLESS OTHERWISE SPECIFIED TOLERANCE	
			MM (PRIMARY)	INCHES (SECONDARY)
			X ±2	X ±.1
			X ±.8	XX ±.03
			XX ±.38	XXX ±.015
FINISH:			HOLE DIA ±0.13	HOLE DIA ±0.005
			ANGULAR	±1.5°
DESIGNED BY:	DATE:	WEIGHT	CONTROL CHARACTERISTICS	
Bryan.Harkin	18/11/2024	1059747.85	FIRST ANGLE PROJECTION	
DRAWN BY:	DATE:	SHEET:	SIZE	SCALE
Bryan.Harkin	10/02/2025	1 / 1	A3	1:50
			DOCUMENT NUMBER	REV
			IO CABINET BACK TO BACK	03



1 2 3 4

CO NO	REV	DESCRIPTION	DRAWN BY:	DATE
			APPROVED BY:	DATE

A

BUSBAR FLANGE DETAIL
WILL BE PROJECT
SPECIFIC AND MAY
DIFFER IN HEIGHT

B

C

D

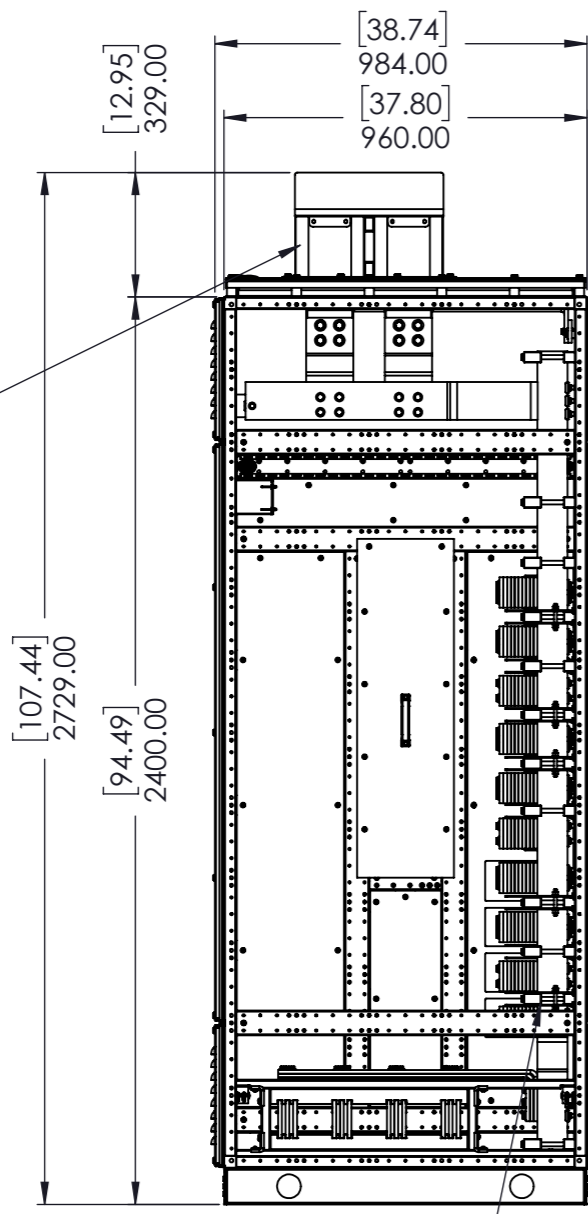

RHS VIEW

NEUTRAL NOT REQUIRED
FOR 3W SYSTEM

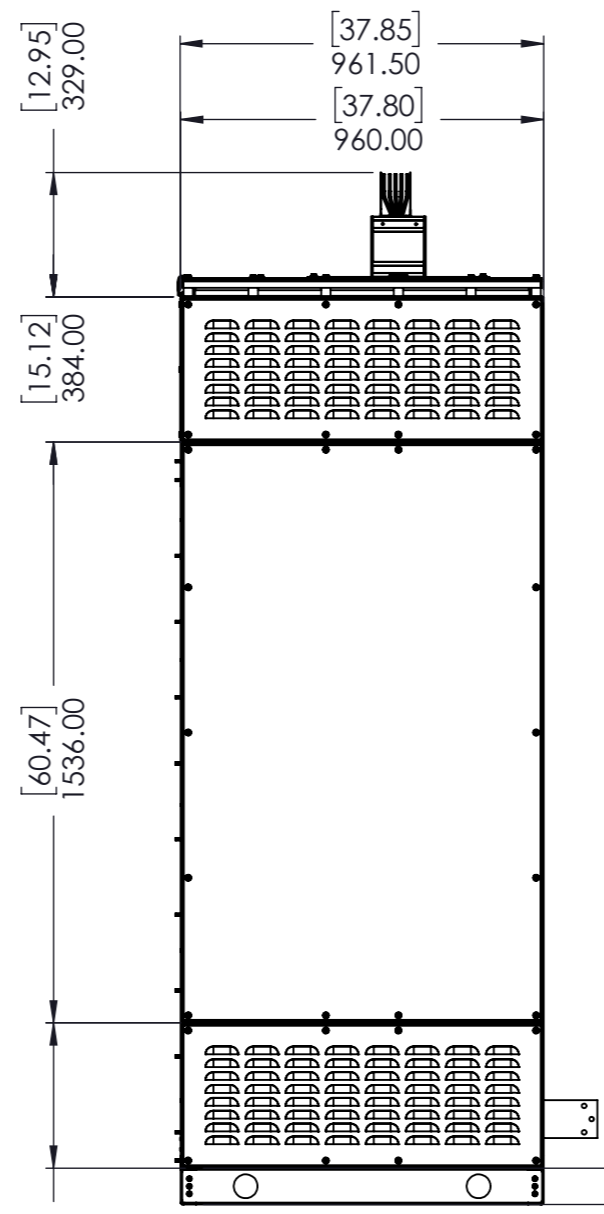

FRONT VIEW

[3.78]
96.00

NEUTRAL NOT REQUIRED
FOR 3W SYSTEM

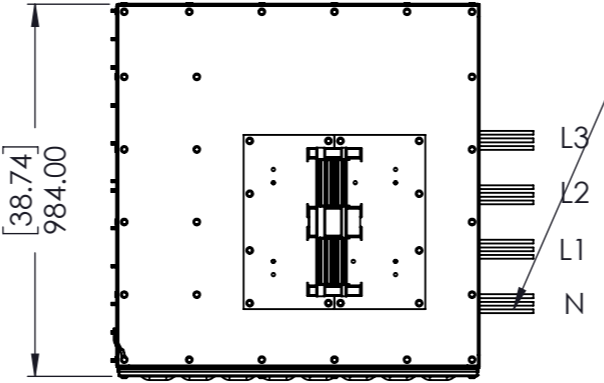

PLAN VIEW

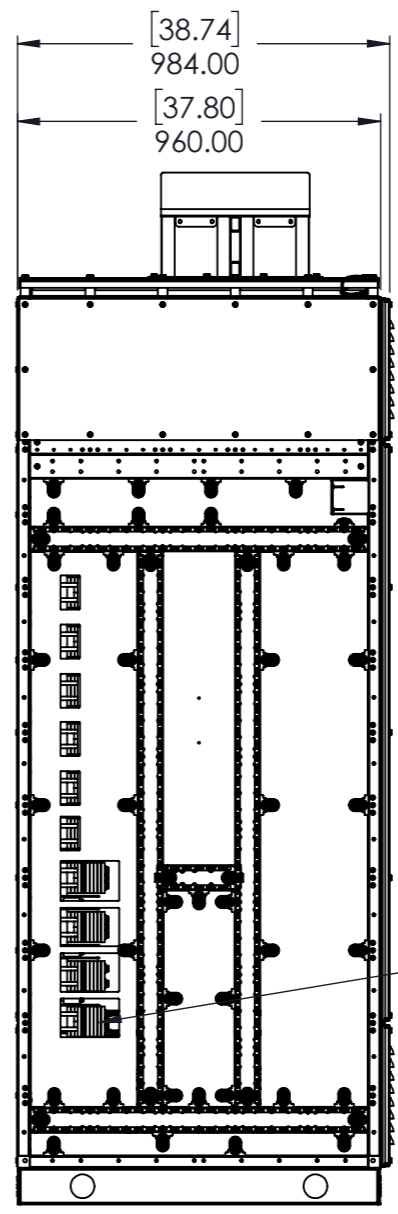

LHS VIEW

NEUTRAL NOT REQUIRED
FOR 3W SYSTEM

NOTES:

- CONSTRUCTION MATERIAL: 2MM THICK POWDER COATED MILD STEEL
- ALL DIMENSIONS IN MILLIMETERS/INCHES
- PROTECTION IEC: IP31
UL: TYPE 1
- ACCESS: FRONT
- BUSBARS ARE DESIGNED FOR A SHORT-CIRCUIT WITHSTAND STRENGTH IEC: 100% (100kA/1SEC)
UL: 3c cycles @ 100kA
- COPPER COULD BE BARE OR TINNED

I	CORPORATE CAGE CODE	505 N. CLEVELAND AVE WESTERVILLE, OHIO 43082	IO CABINET FRONT TO FRONT	DIMENSION DRAWING
	1EDC2		PART NUMBER	DESCRIPTION
<small>© 2018 VERTIV CO. CONFIDENTIAL AND PROPRIETARY. ALL RIGHTS RESERVED. VERTIV AND THE VERTIV LOGO ARE TRADEMARKS OR REGISTERED TRADEMARKS OF VERTIV CO. THIS DOCUMENT AND THE INFORMATION IT CONTAINS ARE THE PROPERTY OF VERTIV CO. BY ACCEPTING IT INTO YOUR POSSESSION, YOU AGREE THAT YOU WILL KEEP THIS DOCUMENT AND ALL INFORMATION CONTAINED HEREIN IN STRICTEST CONFIDENCE AND WILL NOT COPY, RE TRANSMIT, USE (EXCEPT SOLELY FOR THE BENEFIT OF VERTIV CO.), SELL, LEND, OR OTHERWISE DISPOSE OF SAME, DIRECTLY OR INDIRECTLY, WITHOUT THE EXPRESS WRITTEN PERMISSION OF VERTIV CO., AND THIS DOCUMENT SHALL BE RETURNED TO VERTIV CO. IMMEDIATELY UPON REQUEST.</small>				
MATERIAL:		THICKNESS(mm)	UNLESS OTHERWISE SPECIFIED TOLERANCE	
FINISH:			MM (PRIMARY)	INCHES (SECONDARY)
			X ±2	X ±.1
			X ±.8	XX ±.03
			XX ±.38	XXX ±.015
			HOLE DIA ±0.13	HOLE DIA ±0.005
			ANGULAR	±1.5°
DESIGNED BY:	DATE:	WEIGHT	CONTROL CHARACTERISTICS	
Bryan.Harkin	18/11/2024	1182697.08	C	
DRAWN BY:	DATE:	SHEET:	FIRST ANGLE PROJECTION	SIZE
Bryan.Harkin	10/02/2025	1 / 1	— ⊕ —	A3
			SCALE	DOCUMENT NUMBER
			1:50	IO CABINET FRONT TO FRONT
				REV
				03

1 2 3 4

CO NO	REV	DESCRIPTION	DRAWN BY:	DATE
			APPROVED BY:	DATE

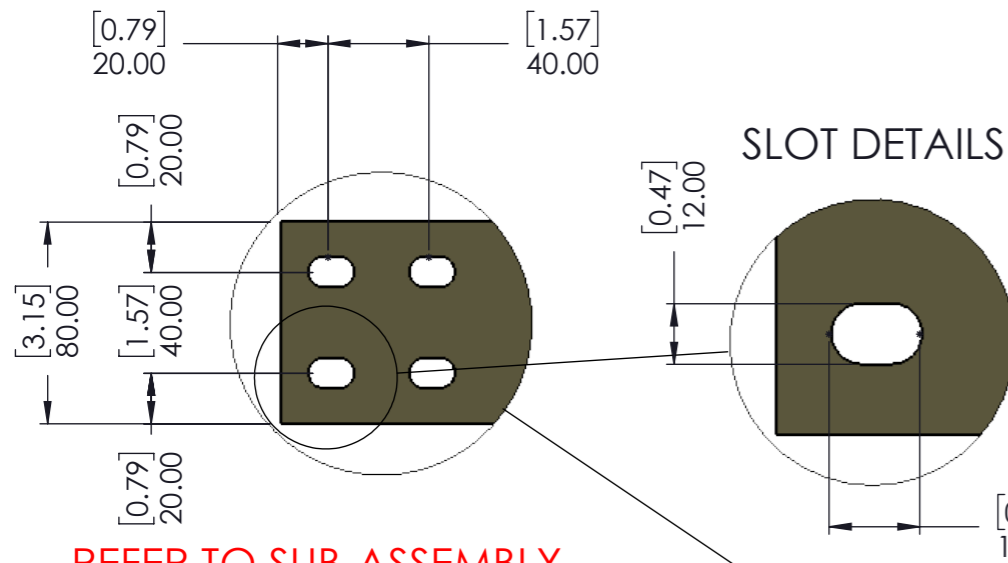

REFER TO SUB-ASSEMBLY IO-CON-0001 FOR CONNECTION DETAILS

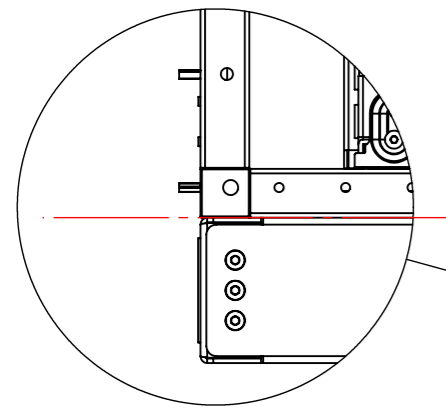
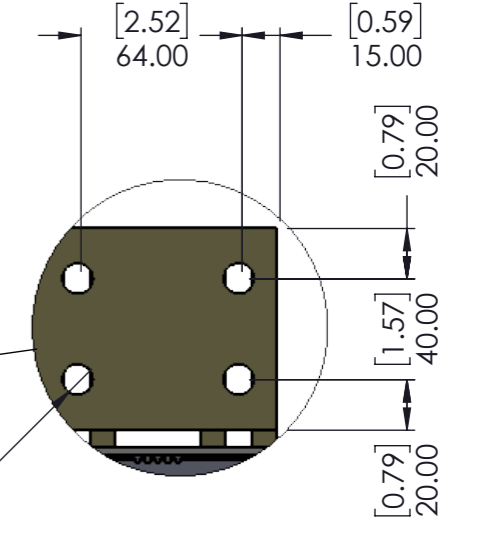
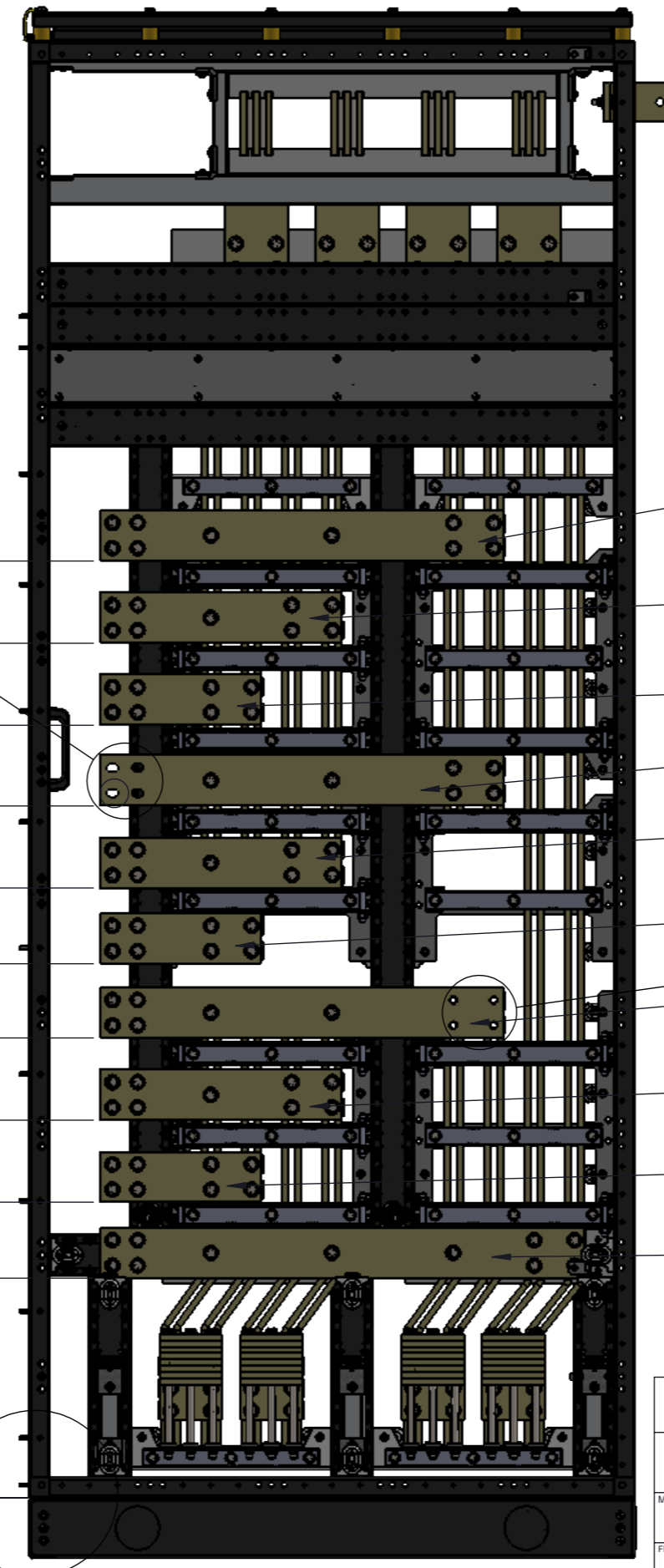

DIMENSIONS ARE TAKEN FROM THE BOTTOM OF THE FRAME BAR

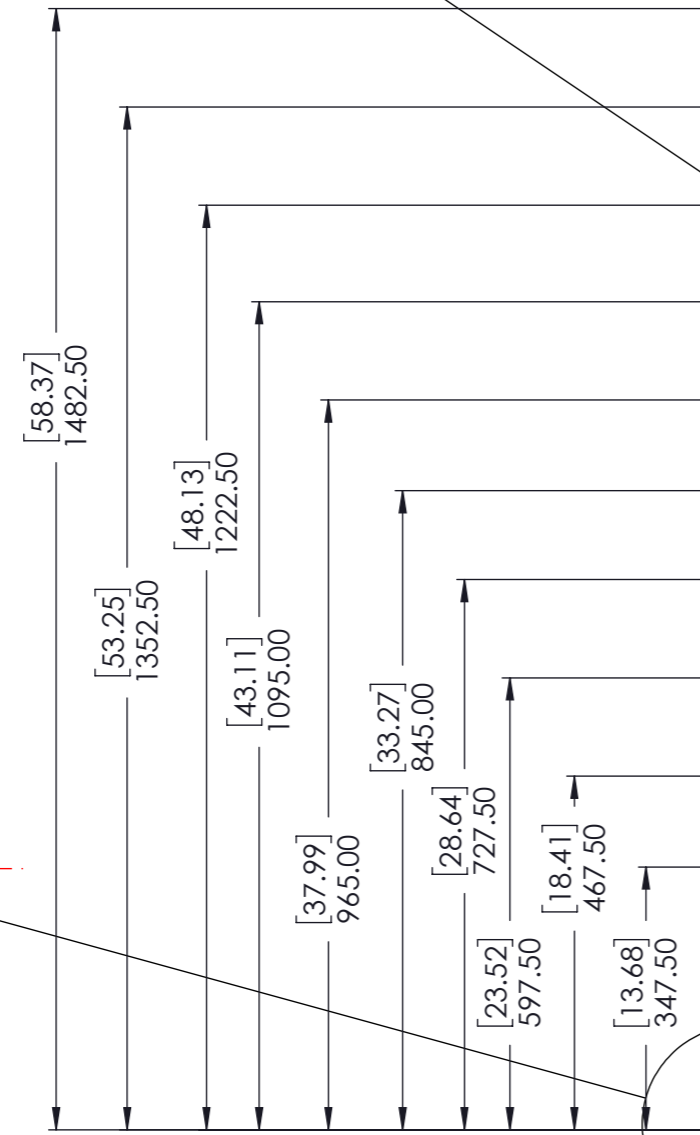

FRONT VIEW

I	CORPORATE CAGE CODE	505 N. CLEVELAND AVE WESTERVILLE, OHIO 43082	IO INTERFACE CONNECTIONS	IO CABINET INTERFACE CONNECTION DETAILS
	1EDC2		PART NUMBER	DESCRIPTION
<small>© 2018 VERTIV CO. CONFIDENTIAL AND PROPRIETARY. ALL RIGHTS RESERVED. VERTIV AND THE VERTIV LOGO ARE TRADEMARKS OR REGISTERED TRADEMARKS OF VERTIV CO. THIS DOCUMENT (AND THE INFORMATION IT CONTAINS) ARE THE PROPERTY OF VERTIV CO. BY ACCEPTING IT INTO YOUR POSSESSION, YOU AGREE THAT YOU WILL KEEP THIS DOCUMENT AND ALL INFORMATION CONTAINED HEREIN IN STRICTEST CONFIDENCE AND WILL NOT COPY, REPRODUCE, TRANSMIT, USE (EXCEPT SOLELY FOR THE BENEFIT OF VERTIV CO.), SELL, LEND, OR OTHERWISE DISPOSE OF SAME, DIRECTLY OR INDIRECTLY, WITHOUT THE EXPRESS WRITTEN PERMISSION OF VERTIV CO., AND THIS DOCUMENT SHALL BE RETURNED TO VERTIV CO. IMMEDIATELY UPON REQUEST.</small>				
MATERIAL:	THICKNESS(mm)		UNLESS OTHERWISE SPECIFIED TOLERANCE	
FINISH:	X	±2	MM (PRIMARY)	INCHES (SECONDARY)
	X	±8	XX	±.1
	XX	±38	XXX	±.03
		±0.13	HOLE DIA	±0.015
			ANGULAR	±1.5°
DESIGNED BY:	DATE:	WEIGHT:	PART DESCRIPTION	
Bryan.Harkin	12/12/2024	865702.84	IO CABINET INTERFACE CONNECTION DETAILS	
DRAWN BY:	DATE:	SHEET:	CONTROL CHARACTERISTICS	SCALE
Bryan.Harkin	26/05/2025	1 / 1	FIRST ANGLE PROJECTION	A3
			SCALE	DOCUMENT NUMBER
			1:10	IO INTERFACE CONNECTIONS
				REV
				02



CO NO	REV	DESCRIPTION	DRAWN BY:	DATE
			APPROVED BY:	DATE

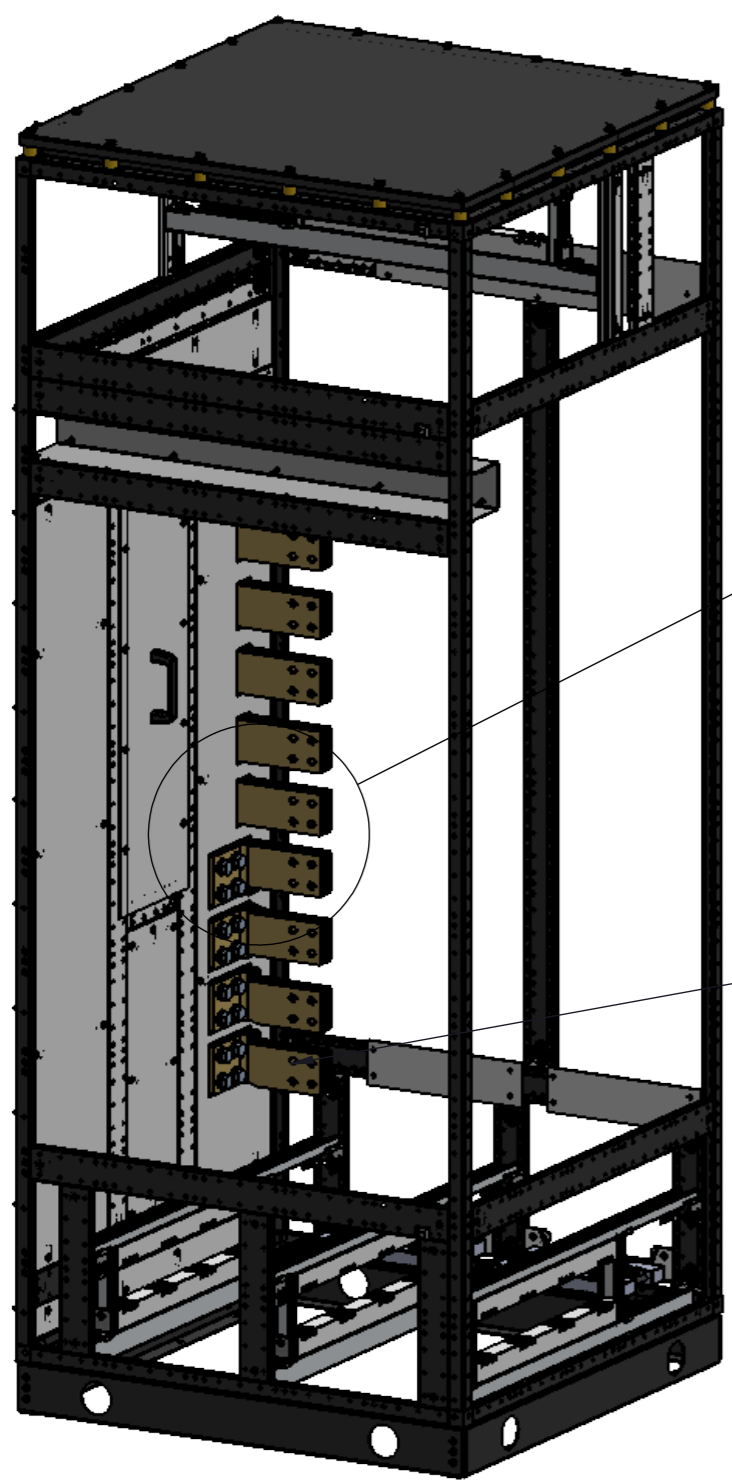

FRONT OF CABINET

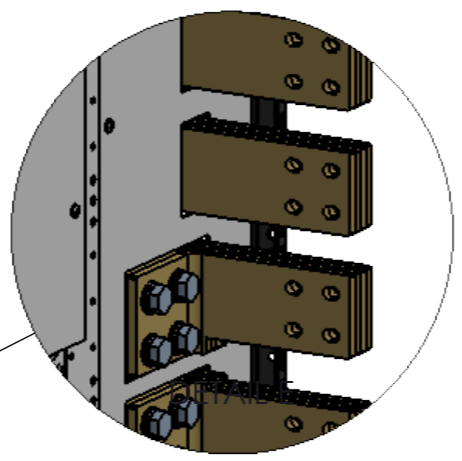

NOTE:
AIR GAP MUST BE MAINTAINED
AROUND COPPER/SLOT
ARRANGEMENT

NEUTRAL NOT REQUIRED
FOR 3W SYSTEM

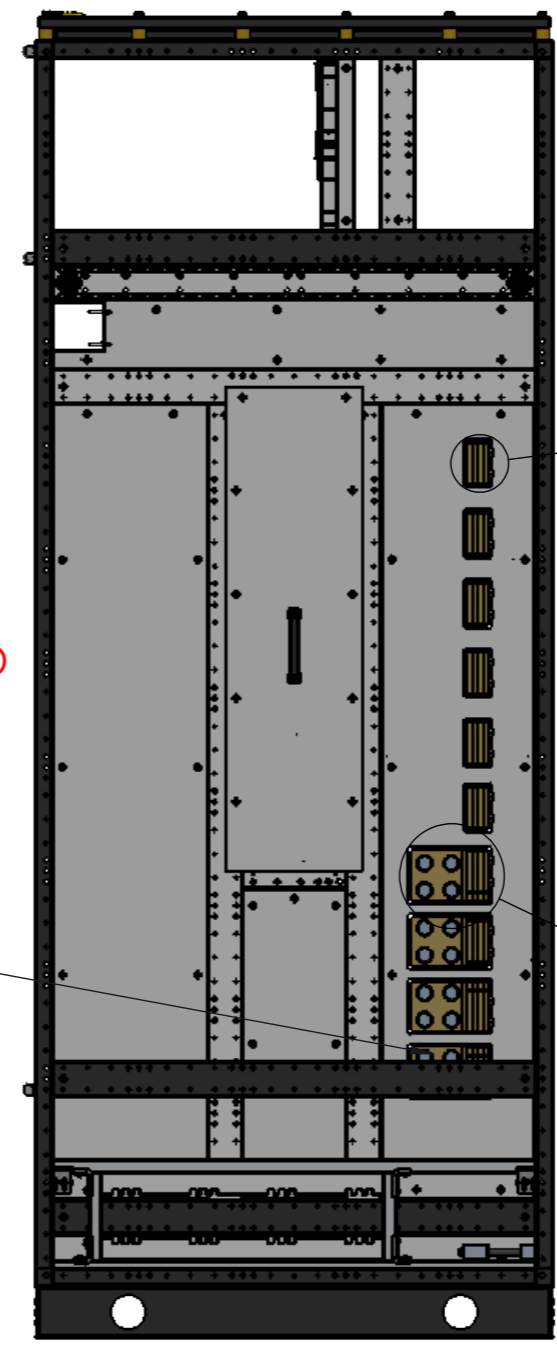

RHS VIEW

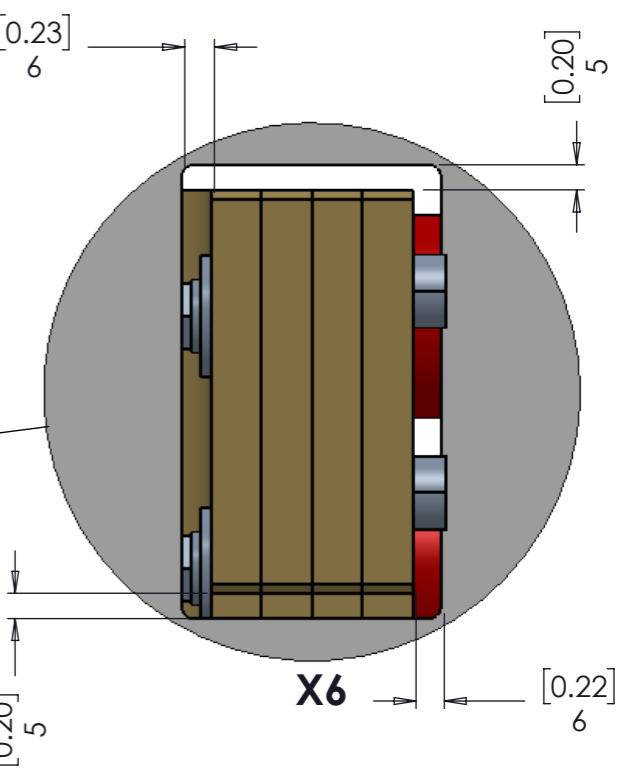

X6

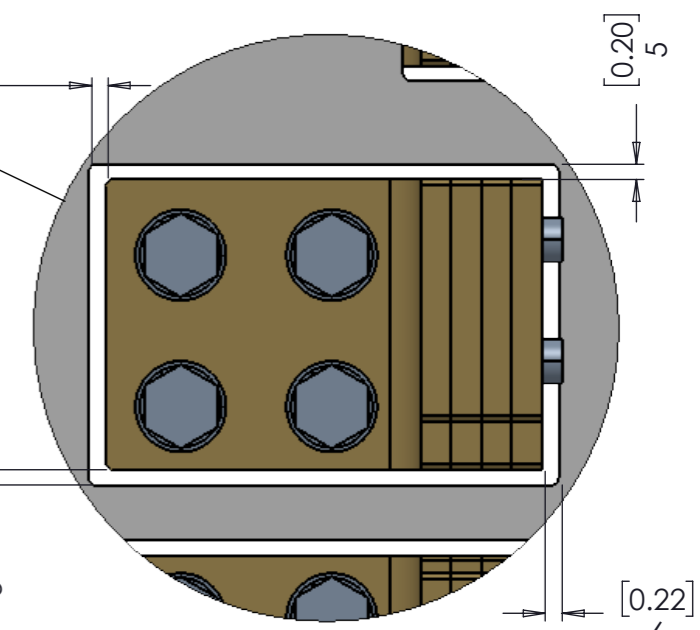

X4

I	CORPORATE CAGE CODE	505 N. CLEVELAND AVE WESTERVILLE, OHIO 43082	STS CONNECTIONS	IO CABINET AND STS INTERFACE CONNECTIONS
	1EDC2		PART NUMBER	DESCRIPTION
<small>© 2018 VERTIV CO. CONFIDENTIAL AND PROPRIETARY. ALL RIGHTS RESERVED. VERTIV AND THE VERTIV LOGO ARE TRADEMARKS OR REGISTERED TRADEMARKS OF VERTIV CO. THIS DOCUMENT AND THE INFORMATION IT CONTAINS ARE THE PROPERTY OF VERTIV CO. BY ACCEPTING IT INTO YOUR POSSESSION, YOU AGREE THAT YOU WILL KEEP THIS DOCUMENT AND ALL INFORMATION CONTAINED HEREIN IN STRICTEST CONFIDENCE AND WILL NOT COPY, RE TRANSMIT, USE (EXCEPT SOLELY FOR THE BENEFIT OF VERTIV CO.), SELL, LEND, OR OTHERWISE DISPOSE OF SAME, DIRECTLY OR INDIRECTLY, WITHOUT THE EXPRESS WRITTEN PERMISSION OF VERTIV CO., AND THIS DOCUMENT SHALL BE RETURNED TO VERTIV CO. IMMEDIATELY UPON REQUEST.</small>				
MATERIAL:		THICKNESS(mm)	UNLESS OTHERWISE SPECIFIED TOLERANCE	
			MM (PRIMARY)	INCHES (SECONDARY)
			X ±.2	X ±.1
			X ±.8	XX ±.03
			XX ±.38	XXX ±.015
			HOLE DIA ±0.13	HOLE DIA ±0.005
			ANGULAR	±1.5*
DESIGNED BY:	DATE:	WEIGHT:	PART DESCRIPTION	
Bryan.Harkin	30/01/2025	218788.93	IO CABINET AND STS INTERFACE CONNECTIONS	
DRAWN BY:	DATE:	SHEET:	CONTROL CHARACTERISTICS	SCALE
Bryan.Harkin	10/02/2025	1 / 1	FIRST ANGLE PROJECTION	A3 1:50
			DOCUMENT NUMBER	REV
			STS CONNECTIONS	



CO NO	REV	DESCRIPTION	DRAWN BY:	DATE
			APPROVED BY:	DATE

1 No. STAINLESS STEEL FRAME BAR
 MIN 3No. FIXING POINTS REQUIRED
 NO EXCEPTIONS IN THE CASE OF THIS BAR ONLY.
 (THIS BAR FORMS THE EARTH CONNECTION
 BETWEEN IO & STS FRAMES)

THIS DRAWING INDICATES ALL
 AVAILABLE FRAME FIXING POINTS,
 FRONT, BACK, TOP & BOTTOM.

REFER TO NEXT DRAWING FOR DETAILS

MINIMUM No. OF FIXING POINTS

Location	Qty	Min No.
Front	10	4
Back	10	3-4
Top	10	3 (NO EXCEPTIONS)
Bottom	10	2-3

N.B
 IDEALLY 1 FIXING NEAR TO THE CORNERS AND THE
 REST SPREAD INBETWEEN THESE.
 FOR EXAMPLE, SEE CIRCLED POSITIONS.

DEPENDING ON REAR ACCESS, OTHER COMBINATIONS
 OF SCREW POSITIONS AND QUANTITIES CAN BE DEEMED
 ACCEPTABLE AT TIME OF INSTALL.

NEUTRAL NOT
 REQUIRED
 FOR 3W SYSTEM

REAR OF PANEL

FRONT OF PANEL

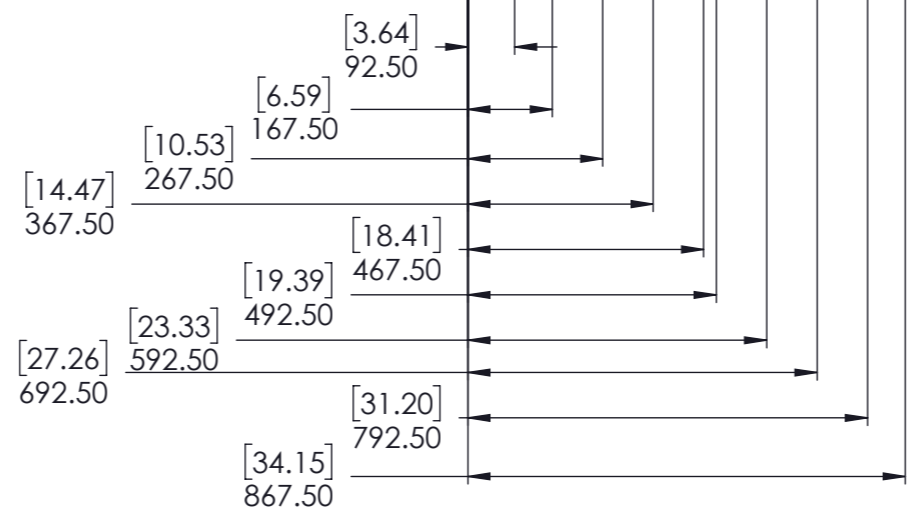

LHS VIEW

I	CORPORATE CAGE CODE	505 N. CLEVELAND AVE WESTERVILLE, OHIO 43082	FRAME CONNECTION DETAILS	FRAME TO FRAME CONNECTION DIENSIONS
	1EDC2		PART NUMBER	DESCRIPTION
<small>© 2018 VERTIV CO. CONFIDENTIAL AND PROPRIETARY. ALL RIGHTS RESERVED. VERTIV AND THE VERTIV LOGO ARE TRADEMARKS OR REGISTERED TRADEMARKS OF VERTIV CO. THIS DOCUMENT AND ALL INFORMATION CONTAINED HEREIN IN STRICTEST CONFIDENCE AND WILL NOT COPY, RETRANSMIT, USE (EXCEPT SOLELY FOR THE BENEFIT OF VERTIV CO.), SELL, LEND, OR OTHERWISE DISPOSE OF SAME, DIRECTLY OR INDIRECTLY, WITHOUT THE EXPRESS WRITTEN PERMISSION OF VERTIV CO., AND THIS DOCUMENT SHALL BE RETURNED TO VERTIV CO. IMMEDIATELY UPON REQUEST.</small>				
MATERIAL:		THICKNESS(mm)	UNLESS OTHERWISE SPECIFIED TOLERANCE	
FINISH:			MM (PRIMARY)	INCHES (SECONDARY)
			X ±2	X ±.1
			X ±.8	XX ±.03
			XX ±.38	XXX ±.015
			HOLE DIA ±0.13	HOLE DIA ±0.005
			ANGULAR	±1.5*
DESIGNED BY:	DATE:	WEIGHT	PART DESCRIPTION	
Bryan.Harkin	29/01/2025	1186225.89	FRAME TO FRAME CONNECTION DIENSIONS	
DRAWN BY:	DATE:	SHEET:	CONTROL CHARACTERISTICS	SCALE
Bryan.Harkin	29/08/2025	1 / 2	FIRST ANGLE PROJECTION	A3 1:50
			DOCUMENT NUMBER	REV
			FRAME CONNECTION DETAILS	01



1

2

3

4

CO NO	REV	DESCRIPTION	DRAWN BY: APPROVED BY:	DATE DATE

A

A

B

B

C

C

D

D

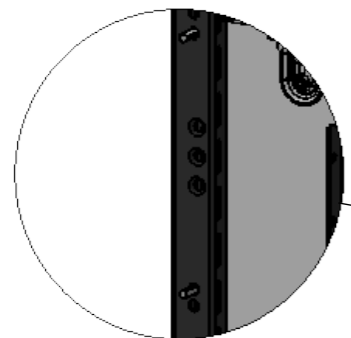
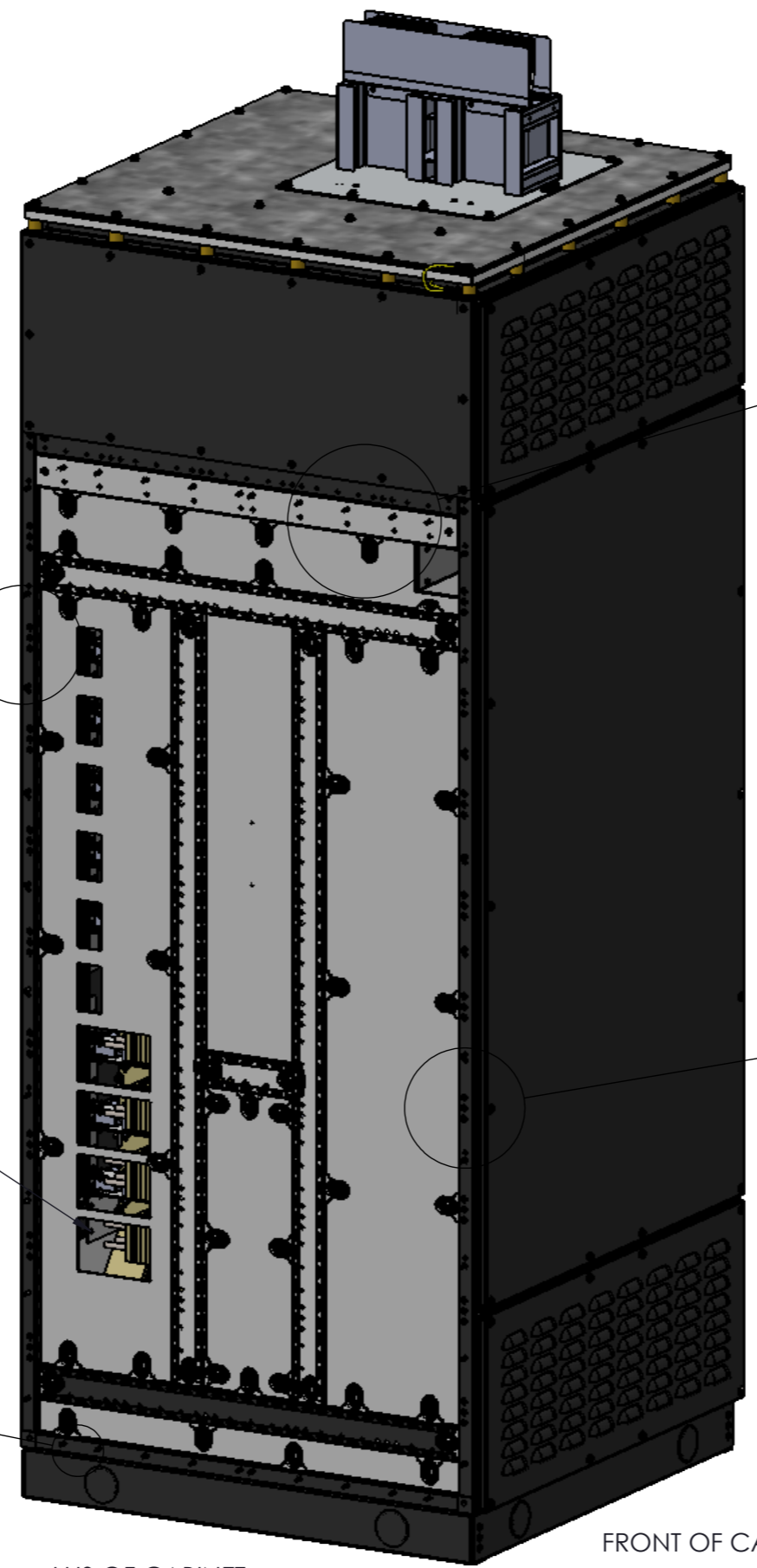

10 No. VERTICAL CONNECTIONS DIRECT TO STS FRAME FIXING HOLES

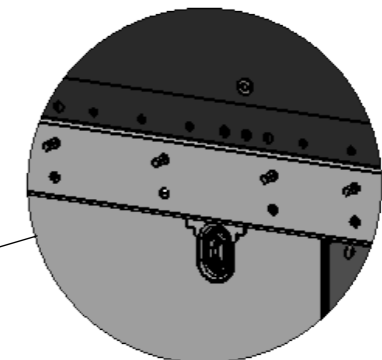

10 No. HORIZONTAL CONNECTIONS DIRECT TO STS FRAME FIXING HOLES

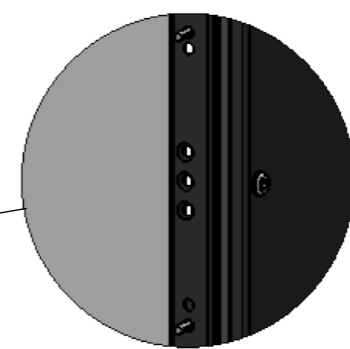

10 No. VERTICAL CONNECTIONS DIRECT TO STS FRAME FIXING HOLES

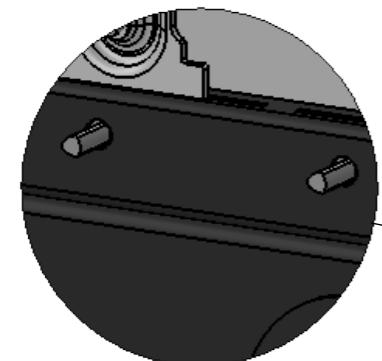

10 No. HORIZONTAL CONNECTIONS DIRECT TO STS FRAME FIXING HOLES

NEUTRAL NOT REQUIRED FOR 3W SYSTEM

LHS OF CABINET

FRONT OF CABINET

I	CORPORATE CAGE CODE	505 N. CLEVELAND AVE WESTERVILLE, OHIO 43082	FRAME CONNECTION DETAILS	FRAME TO FRAME CONNECTION DETAILS
	1EDC2		PART NUMBER	DESCRIPTION
<small>© 2018 VERTIV CO. CONFIDENTIAL AND PROPRIETARY. ALL RIGHTS RESERVED. VERTIV AND THE VERTIV LOGO ARE TRADEMARKS OR REGISTERED TRADEMARKS OF VERTIV CO. THIS DOCUMENT (AND THE INFORMATION IT CONTAINS) ARE THE PROPERTY OF VERTIV CO. BY ACCEPTING IT INTO YOUR POSSESSION, YOU AGREE THAT YOU WILL KEEP THIS DOCUMENT AND ALL INFORMATION CONTAINED HEREIN IN STRICTEST CONFIDENCE AND WILL NOT COPY, RE TRANSMIT, USE (EXCEPT SOLELY FOR THE BENEFIT OF VERTIV CO.), SELL, LEND, OR OTHERWISE DISPOSE OF SAME, DIRECTLY OR INDIRECTLY, WITHOUT THE EXPRESS WRITTEN PERMISSION OF VERTIV CO., AND THIS DOCUMENT SHALL BE RETURNED TO VERTIV CO. IMMEDIATELY UPON REQUEST.</small>				
MATERIAL:		THICKNESS(mm)	UNLESS OTHERWISE SPECIFIED TOLERANCE	
			MM (PRIMARY)	INCHES (SECONDARY)
			X ±2	X ±.1
			X ±.8	XX ±.03
			XX ±.38	XXX ±.015
FINISH:			HOLE DIA ±0.13	HOLE DIA ±0.005
			ANGULAR	±1.5*
DESIGNED BY:	DATE:	WEIGHT:	CONTROL CHARACTERISTICS	
Bryan.Harkin	29/01/2025	1186225.89		
DRAWN BY:	DATE:	SHEET:	FIRST ANGLE PROJECTION	SIZE SCALE
Bryan.Harkin	29/08/2025	2 / 2		A3 1:50
			PART DESCRIPTION	
			FRAME TO FRAME CONNECTION DETAILS	
			DOCUMENT NUMBER	REV
			FRAME CONNECTION DETAILS	00

1

2

3

4

1

2

3

4

CO NO	REV	DESCRIPTION	DRAWN BY: APPROVED BY:	DATE DATE

A

A

B

B

C

C

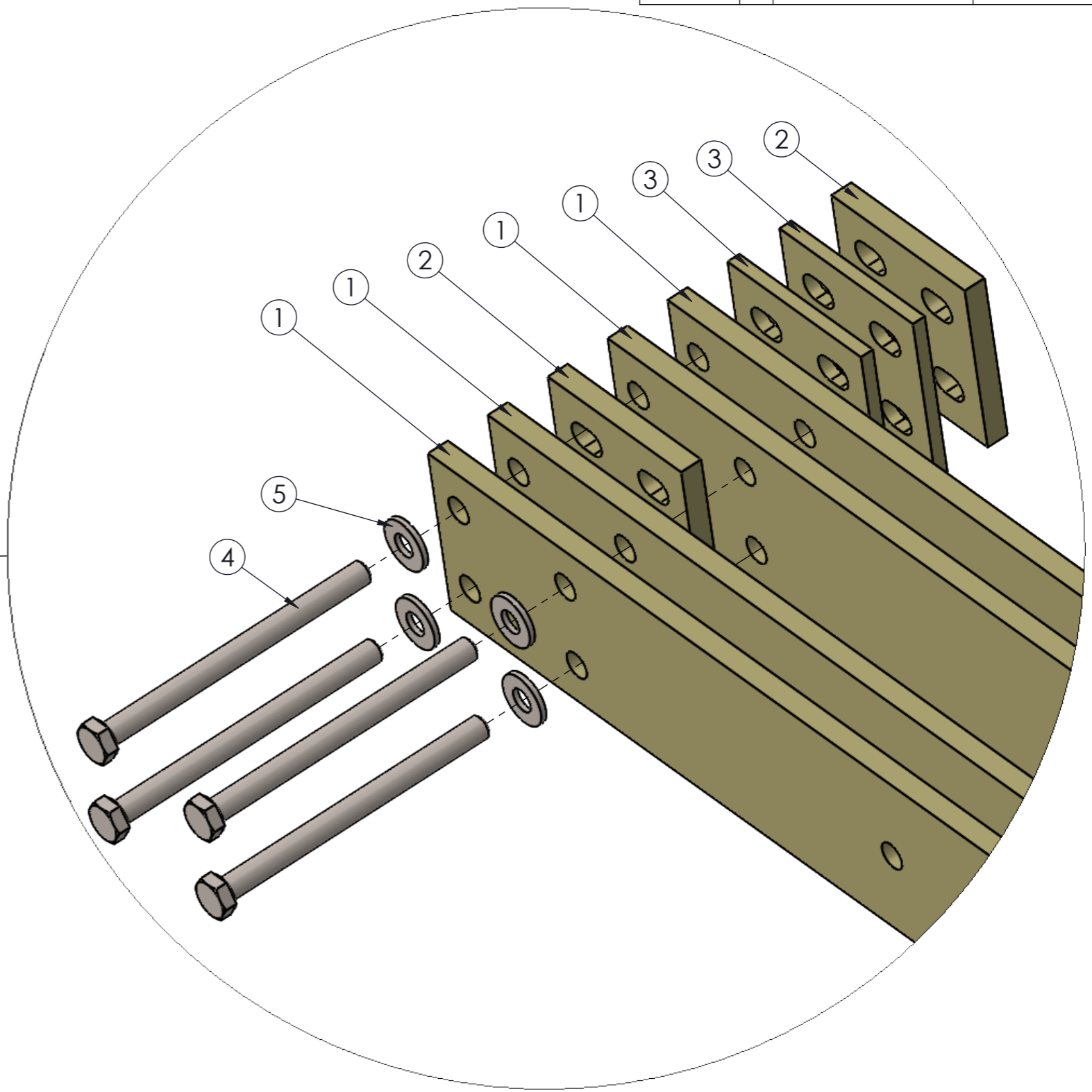
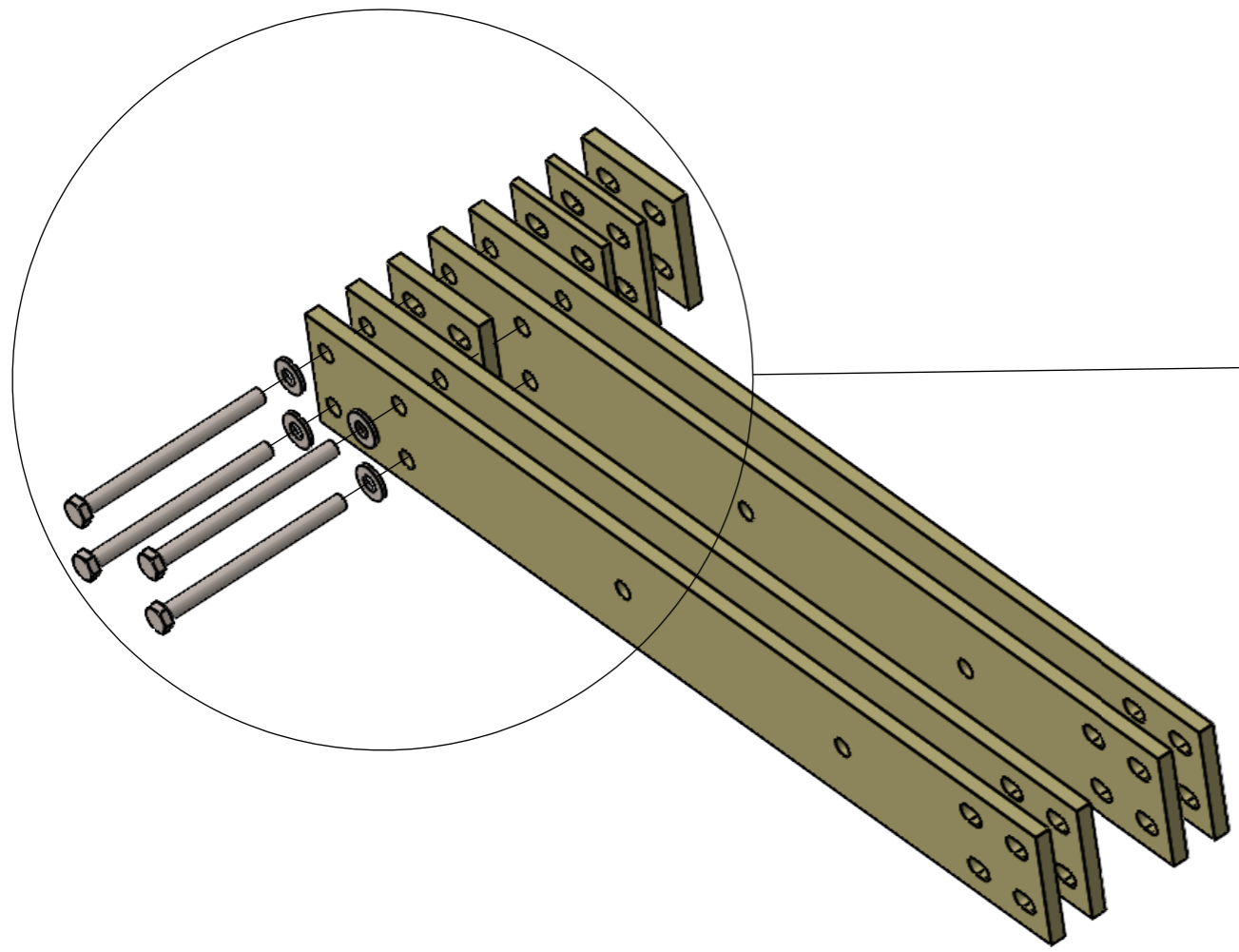

REDUCED QUANTITIES FOR 3W SYSTEM (1 LESS CONNECTION THAN 4W)

ITEM NO.	PART NUMBER	DESCRIPTION	4W TOTAL QTY.	3W TOTAL QTY
2	IOC-PK-80X80X10	IOC-PK-80X80X10	20	18
3	IOC-PK-80X80X6	IOC-PK-80X80X6	20	18
4	M10X130	M10X130	40	36
5	CU-2018-1000	10mm Conical Washers 5x23x2.5	40	36

N.B REFER TO INSTALLATION MANUAL FOR TORQUE LEVELS

I	CORPORATE CAGE CODE	505 N. CLEVELAND AVE WESTERVILLE, OHIO 43082	IO-CON-0001	INTERFACE CONNECTION DETAILS
	1EDC2		PART NUMBER	DESCRIPTION
<small>© 2018 VERTIV CO. CONFIDENTIAL AND PROPRIETARY. ALL RIGHTS RESERVED. VERTIV AND THE VERTIV LOGO ARE TRADEMARKS OR REGISTERED TRADEMARKS OF VERTIV CO. THIS DOCUMENT AND THE INFORMATION IT CONTAINS ARE THE PROPERTY OF VERTIV CO. BY ACCEPTING IT INTO YOUR POSSESSION, YOU AGREE THAT YOU WILL KEEP THIS DOCUMENT AND ALL INFORMATION CONTAINED HEREIN IN STRICTEST CONFIDENCE AND WILL NOT COPY, RE TRANSMIT, USE (EXCEPT SOLELY FOR THE BENEFIT OF VERTIV CO.), SELL, LEND, OR OTHERWISE DISPOSE OF SAME, DIRECTLY OR INDIRECTLY, WITHOUT THE EXPRESS WRITTEN PERMISSION OF VERTIV CO., AND THIS DOCUMENT SHALL BE RETURNED TO VERTIV CO. IMMEDIATELY UPON REQUEST.</small>				
MATERIAL:		THICKNESS(mm)	UNLESS OTHERWISE SPECIFIED TOLERANCE	
SEE DETAILS			MM (PRIMARY)	INCHES (SECONDARY)
			X ±2	X ±.1
			X ±.8	XX ±.03
			XX ±.38	XXX ±.015
FINISH:			HOLE DIA ±0.13	HOLE DIA ±0.005
xxx			ANGULAR	±1.5*
DESIGNED BY:	DATE:	WEIGHT	CONTROL CHARACTERISTICS	
Bryan.Harkin	30/01/2025	19369.36	FIRST ANGLE PROJECTION	
DRAWN BY:	DATE:	SHEET:	SIZE	SCALE
Bryan.Harkin	10/02/2025	1 / 1	A3	1:5
			DOCUMENT NUMBER	REV
			IO-CON-0001	

1

2

3

4

D

D

1

2

3

4

CO NO	REV	DESCRIPTION	DRAWN BY:	DATE
			APPROVED BY:	DATE

A

A

B

B

C

C

D

D

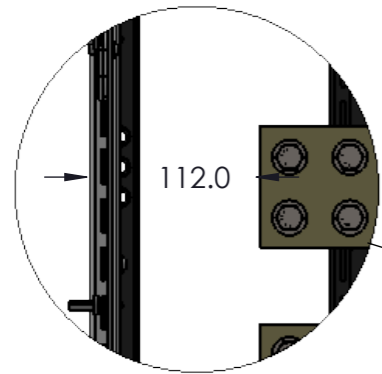

DIMENSION TO
OUTSIDE OF
FRAME BAR

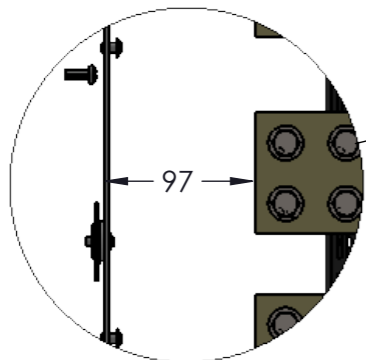

DIMENSION TO
INSIDE FACE
OF SEGREGATION

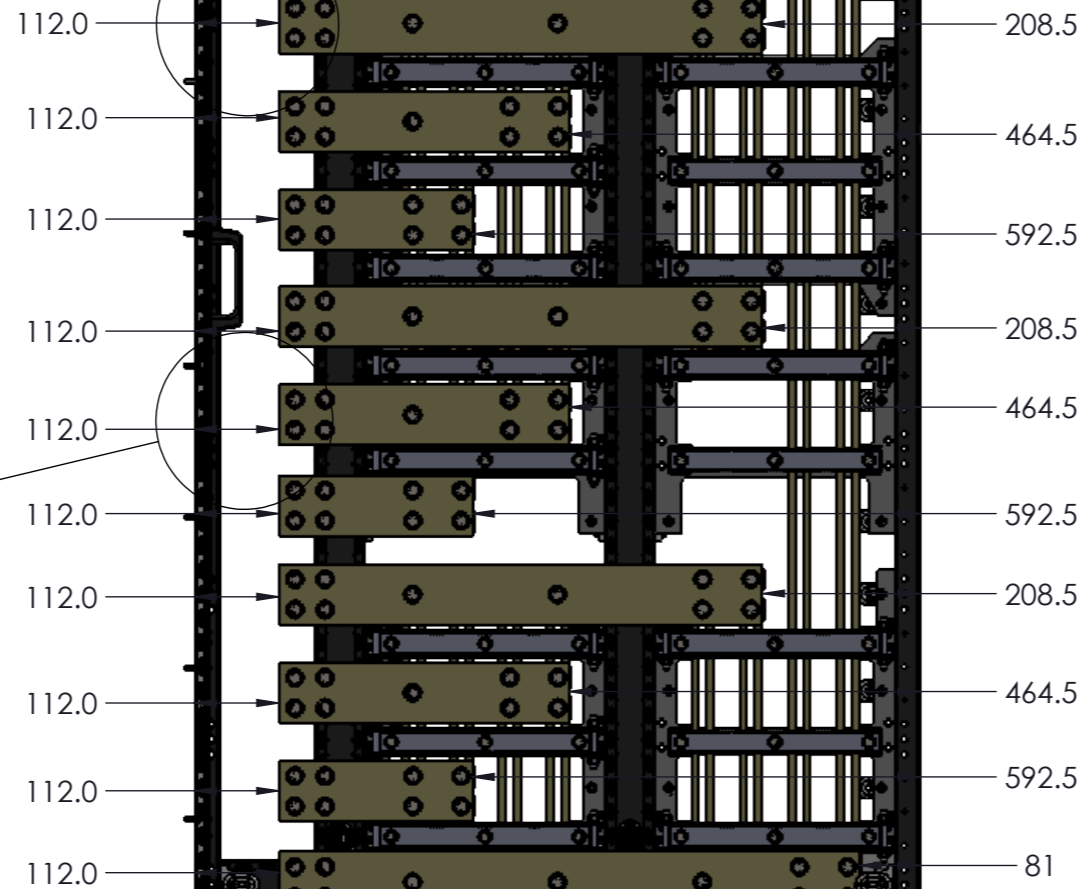

FRONT VIEW

I	CORPORATE CAGE CODE	505 N. CLEVELAND AVE WESTERVILLE, OHIO 43082	IO INTERFACE CONNECTIONS	IO CABINET INTERFACE CONNECTION DETAILS
	1EDC2		PART NUMBER	DESCRIPTION
<small>© 2018 VERTIV CO. CONFIDENTIAL AND PROPRIETARY. ALL RIGHTS RESERVED. VERTIV AND THE VERTIV LOGO ARE TRADEMARKS OR REGISTERED TRADEMARKS OF VERTIV CO. THIS DOCUMENT AND THE INFORMATION IT CONTAINS ARE THE PROPERTY OF VERTIV CO. BY ACCEPTING IT INTO YOUR POSSESSION, YOU AGREE THAT YOU WILL KEEP THIS DOCUMENT AND ALL INFORMATION CONTAINED HEREIN IN STRICTEST CONFIDENCE AND WILL NOT COPY, RE TRANSMIT, USE (EXCEPT SOLELY FOR THE BENEFIT OF VERTIV CO.), SELL, LEND, OR OTHERWISE DISPOSE OF SAME, DIRECTLY OR INDIRECTLY, WITHOUT THE EXPRESS WRITTEN PERMISSION OF VERTIV CO., AND THIS DOCUMENT SHALL BE RETURNED TO VERTIV CO. IMMEDIATELY UPON REQUEST.</small>				
MATERIAL:	THICKNESS(mm)	UNLESS OTHERWISE SPECIFIED TOLERANCE		
		MM (PRIMARY)	INCHES (SECONDARY)	
		X ±.2	X	±.1
		.X ±.8	.XX	±.03
		.XX ±.38	.XXX	±.015
FINISH:		HOLE DIA	±0.13	HOLE DIA ±0.005
		ANGULAR	±1.5*	
DESIGNED BY:	DATE:	WEIGHT	PART DESCRIPTION	
Bryan.Harkin	12/12/2024	894375.01	IO CABINET INTERFACE CONNECTION DETAILS	
DRAWN BY:	DATE:	SHEET:	FIRST ANGLE PROJECTION	SCALE
Bryan.Harkin	13/05/2025	1 / 1		A3 1:10
			SIZE	DOCUMENT NUMBER
				IO INTERFACE CONNECTIONS 01



1

2

3

4

1

2

3

4

CO NO	REV	DESCRIPTION	DRAWN BY: APPROVED BY:	DATE DATE

A

A

B

B

C

C

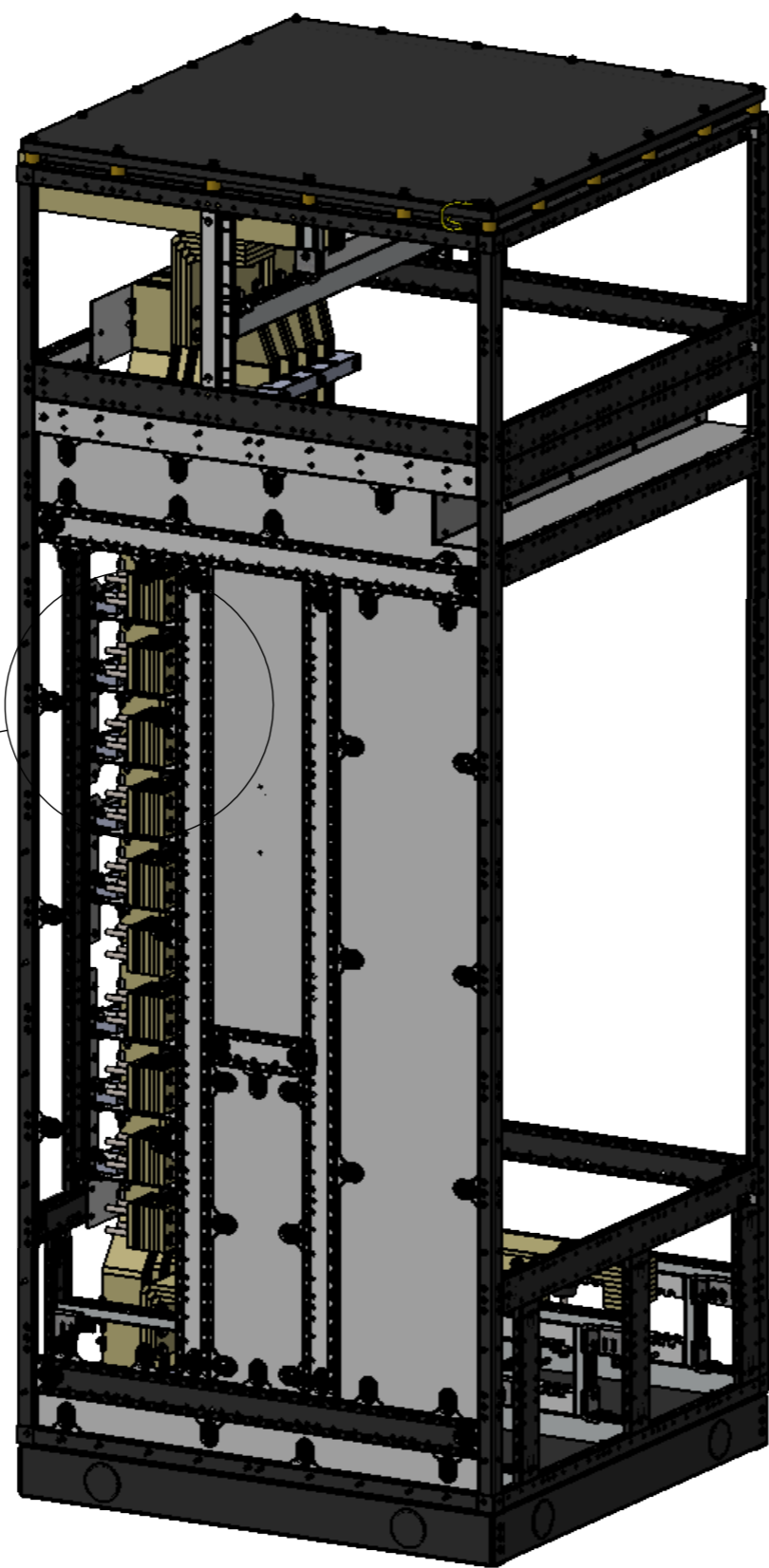
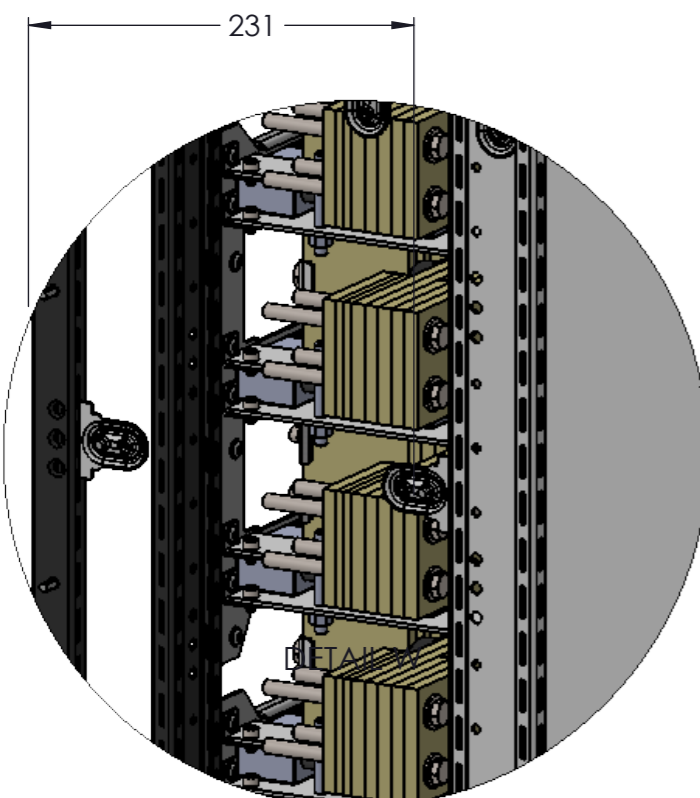

LHS VIEW

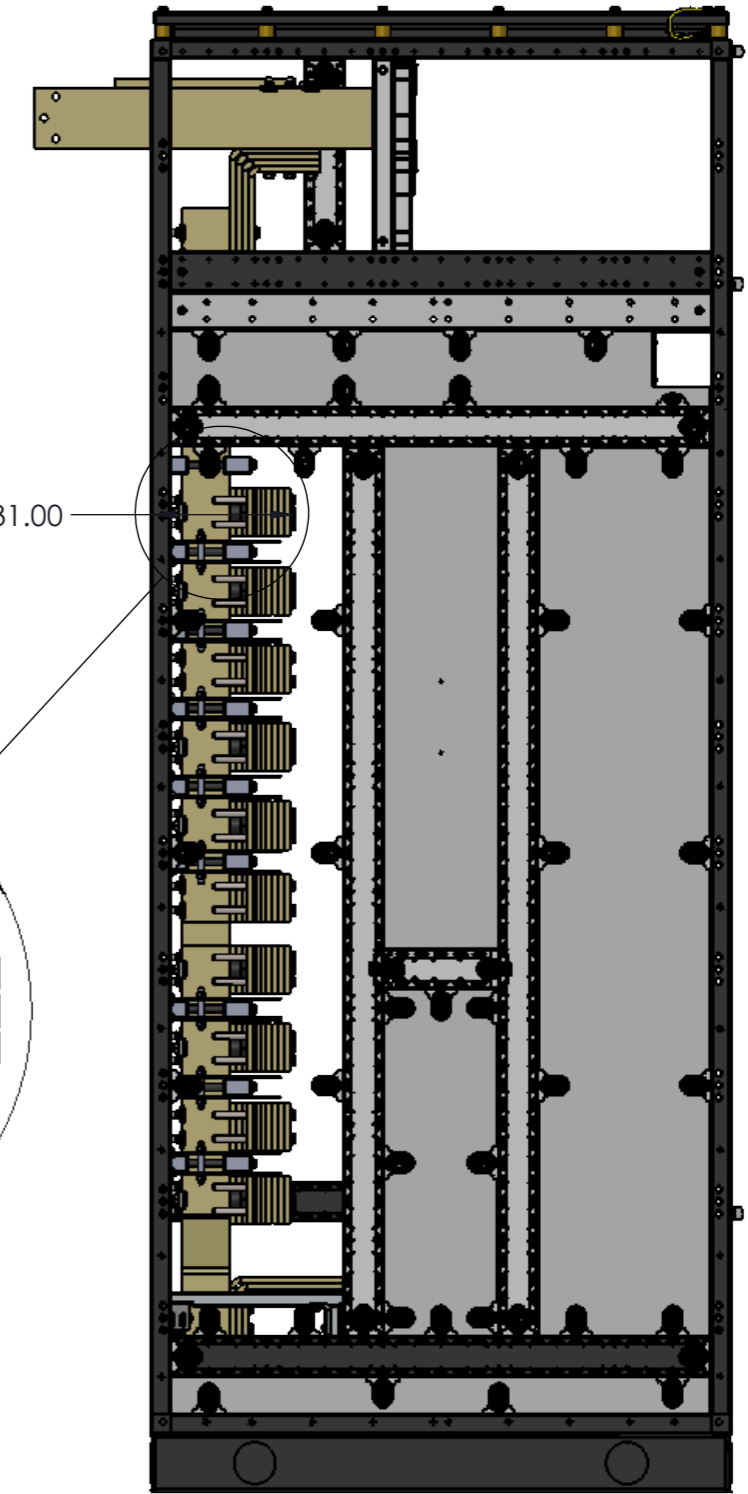
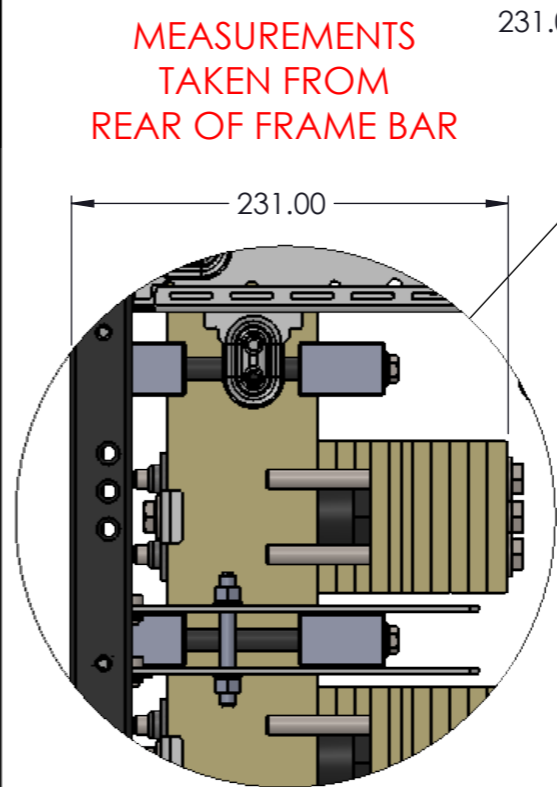

LHS VIEW

D

D

I	CORPORATE CAGE CODE	505 N. CLEVELAND AVE WESTERVILLE, OHIO 43082	IO INTERFACE CONNECTIONS	IO CABINET INTERFACE CONNECTION DETAILS
	1EDC2		PART NUMBER	DESCRIPTION
<small>© 2018 VERTIV CO. CONFIDENTIAL AND PROPRIETARY. ALL RIGHTS RESERVED. VERTIV AND THE VERTIV LOGO ARE TRADEMARKS OR REGISTERED TRADEMARKS OF VERTIV CO. THIS DOCUMENT (AND THE INFORMATION IT CONTAINS) ARE THE PROPERTY OF VERTIV CO. BY ACCEPTING IT INTO YOUR POSSESSION, YOU AGREE THAT YOU WILL KEEP THIS DOCUMENT AND ALL INFORMATION CONTAINED HEREIN IN STRICTEST CONFIDENCE AND WILL NOT COPY, RE TRANSMIT, USE (EXCEPT SOLELY FOR THE BENEFIT OF VERTIV CO.), SELL, LEND, OR OTHERWISE DISPOSE OF SAME, DIRECTLY OR INDIRECTLY, WITHOUT THE EXPRESS WRITTEN PERMISSION OF VERTIV CO., AND THIS DOCUMENT SHALL BE RETURNED TO VERTIV CO. IMMEDIATELY UPON REQUEST.</small>				
MATERIAL:		THICKNESS(mm)	UNLESS OTHERWISE SPECIFIED TOLERANCE	
FINISH:			MM (PRIMARY)	INCHES (SECONDARY)
			X ±.2	X ±.1
			X ±.8	XX ±.03
			XX ±.38	XXX ±.015
			HOLE DIA ±0.13	HOLE DIA ±0.005
			ANGULAR	±1.5*
DESIGNED BY:	DATE:	WEIGHT:	PART DESCRIPTION	
Bryan.Harkin	12/12/2024	894375.01	IO CABINET INTERFACE CONNECTION DETAILS	
DRAWN BY:	DATE:	SHEET:	CONTROL CHARACTERISTICS	SCALE
Bryan.Harkin	13/05/2025	1 / 1	FIRST ANGLE PROJECTION	A3 1:12.5
			DOCUMENT NUMBER	REV
			IO INTERFACE CONNECTIONS	01

1

2

3

4