



# PowerBoard Go

Installer/User Guide

The information contained in this document is subject to change without notice and may not be suitable for all applications. While every precaution has been taken to ensure the accuracy and completeness of this document, Vertiv assumes no responsibility and disclaims all liability for damages result from use of this information or for any errors or omissions.

Refer to local regulations and building codes relating to the application, installation, and operation of this product. The consulting engineer, installer, and/or end user is responsible for compliance with all applicable laws and regulations relation to the application, installation, and operation of this product.

The products covered by this instruction manual are manufactured and/or sold by Vertiv. This document is the property of Vertiv and contains confidential and proprietary information owned by Vertiv. Any copying, use, or disclosure of it without the written permission of Vertiv is strictly prohibited.

Names of companies and products are trademarks or registered trademarks of the respective companies. Any questions regarding usage of trademark names should be directed to the original manufacturer.

### **Technical Support Site**

If you encounter any installation or operational issues with your product, check the pertinent section of this manual to see if the issue can be resolved by following outlined procedures.

Visit <https://www.vertiv.com/en-us/support/> for additional assistance.

## TABLE OF CONTENTS

<b>1 Important Safety Instructions</b> .....	<b>1</b>
<b>2 Introduction</b> .....	<b>1</b>
2.1 General Information .....	1
2.2 Product Overview .....	1
2.3 Design Features and Components .....	4
2.4 Typical Switchboard Layouts .....	5
2.5 Typical Customer Connections .....	6
2.6 Typical Ground Layout .....	7
2.7 Technical Information .....	8
2.8 Labels and Markings .....	10
<b>3 Packaging and Handling</b> .....	<b>11</b>
3.1 Receiving .....	11
3.2 Handling .....	11
3.2.1 Unloading from Truck .....	11
3.2.2 Unloading off Pallet .....	12
3.3 Storage .....	14
<b>4 Installation</b> .....	<b>15</b>
4.1 Pre-Installation Preparation .....	15
4.2 Considerations for Installation .....	15
4.3 Anchoring .....	15
4.4 Joining Sections .....	17
4.4.1 Splice Plates .....	18
4.4.2 Ground Bus Connection .....	19
4.5 Electrical Connections .....	19
4.6 Cable Connections .....	20
4.6.1 Lashing .....	20
<b>5 Energization</b> .....	<b>23</b>
5.1 Pre-Energization .....	23
5.1.1 Pre-Energization Tests .....	23
5.1.2 Energization or Startup .....	23
<b>6 Maintenance</b> .....	<b>25</b>
6.1 Setting Up a Maintenance Schedule .....	25
6.2 Maintenance Inspections .....	25
<b>7 Torque Table</b> .....	<b>27</b>
<b>Appendices</b> .....	<b>29</b>
Appendix A: Technical Support and Contacts .....	29
Appendix B: Warranties and Liabilities .....	30

This page intentionally left blank

# 1 Important Safety Instructions

All information provided in this instruction manual and additional referenced documentation should be reviewed and acknowledged by all personnel responsible for the use of the equipment. All models represented in this manual are for illustrative purposes only, due to the individual specifications associated with each customer. Vertiv will not assume responsibility for actual use established by the models.

Proper installation, operation, and maintenance are critical to the performance of the equipment. Correct operating conditions in terms of input voltage, current, and the fault capacities must be ensured at the time of installing Vertiv™ PowerBoard Go. Refer **ANSI C37.20.1** for abnormal operational conditions.

Reproduction of any part of this manual, without written permission from Vertiv Corp., is prohibited.

Vertiv does not take any responsibility for any of the following:

- Stored the unit in clean, dry, and cool location protected from excessive humidity and heat sources.
- Careless handling of the switchboard system.
- Inadequate maintenance and disregard of the information within this manual and support documentation.
- Improper additions performed on the equipment.
- Untrained or unauthorized personnel working on the equipment (operation, installation, and maintenance).
- Negligence of following appropriate standards per the National Electrical Safety Code (ANSI C2) and Electrical Equipment Maintenance (NFPA 70E).

## General instructions

- Read all the instructions included in this Installer/User Guide before working with the equipment.
- Store and keep this Installer/User Guide to ensure proper commissioning and maintenance to ensure the prolonged use of the equipment.
- Install the switchboard based on the design limitations as given in this Installer/User Guide. The design limitations are presented on the main nameplate and should never be installed in applications that exceed the limits presented by the nameplate.
- Always follow standard safety protocols set forth by your company.
- Turn off all the power sources and de-energize the equipment before removing the covers and opening of doors of the equipment excluding instrument compartment doors, which should only be opened by qualified personnel. All components should be locked out and tagged in line with standard protocol and ANSI Standard Z244.1 Control of Hazardous Energy – Lockout/Tagout.
- Wear proper PPEs while working on the switchboard.
- Personnel performing any type of duties on the equipment should have knowledge of all safety procedures related to their area, this includes and is not limited to local, regional, industrial, governmental, ISO and OSHA.
- Common sense and good judgment should be used while dealing with the equipment to help avoid potential hazards to themselves and others.
- This manual is not to be used or substituted for sufficient training and experience in safety procedures related to the equipment. Fully qualified personnel should be used.
- If additional information is needed, please contact your Vertiv representative.

This page intentionally left blank

## 2 Introduction

### 2.1 General Information

Vertiv™ PowerBoard Go switchboard is a configure at speed solution that improves efficiency, saves space, and enhances operator safety. The PowerBoard Go is engineered with our data center expertise to exceed UL891 standards. PowerBoard Go includes group mounted distribution sections with molded case circuit breakers rated up to 1200 A and captive splice plates for hassle free future expansion.

Features of Vertiv™ PowerBoard Go:

- Fully configure to order design for flexibility.
- Pre-configured switchboard to minimize lead time from order to delivery.
- Switchboards are circuit breakers agnostic.
- Fully rated tin-plated aluminum or copper bus option.
- Available in NEMA type 1 construction for indoor applications.
- Main bus ampacity is up to 4000 A and interrupt rating up to 100 kAIC.
- Space saving group mounted the distribution section.
- Captive splice plates for hassle free installation and future expansion.
- UL489 molded case circuit breakers (MCCBs) and UL489 air circuit breakers (ACBs) are available from different manufacturers.
- Front accessible with top or bottom entry and exit possible.
- PowerBoard Go can be supplied in individual sections for ease of shipping and installation.
- Provisions for surge protection devices and customer metering.
- Optional energy reduction maintenance switches for all breaker types.

### 2.2 Product Overview

#### Compact

Vertiv manufactures one of the most compact switchboard designs in the North American market. PowerBoard Go switchboards packs more power into a smaller footprint, with our design offering a standard shallow depth of 37 in.. This design helps our customer to accommodate the demand for higher power capacity without losing valuable real estate.

#### Safe and Reliable

Designed, built, tested, and certified with UL891 standard, the design of PowerBoard Go is focused on achieving the highest standard of performance, reliability, and operator safety. The dead front enclosure is designed respective NEMA type-standard for indoor application. Though customers can access the instruments compartment from the front without de-energizing, it is not recommended.

## Flexible

Vertiv modular PowerBoard Go design facilitates a component agnostic solution, giving the customer more freedom to choose their preferred components from an extensive range of well-known manufacturers. Designs can be customized to fit the most challenging specifications and site-specific needs, while minimizing space requirement and maximizing performance.

**Figure 2.1 Typical Switchboard Front View**

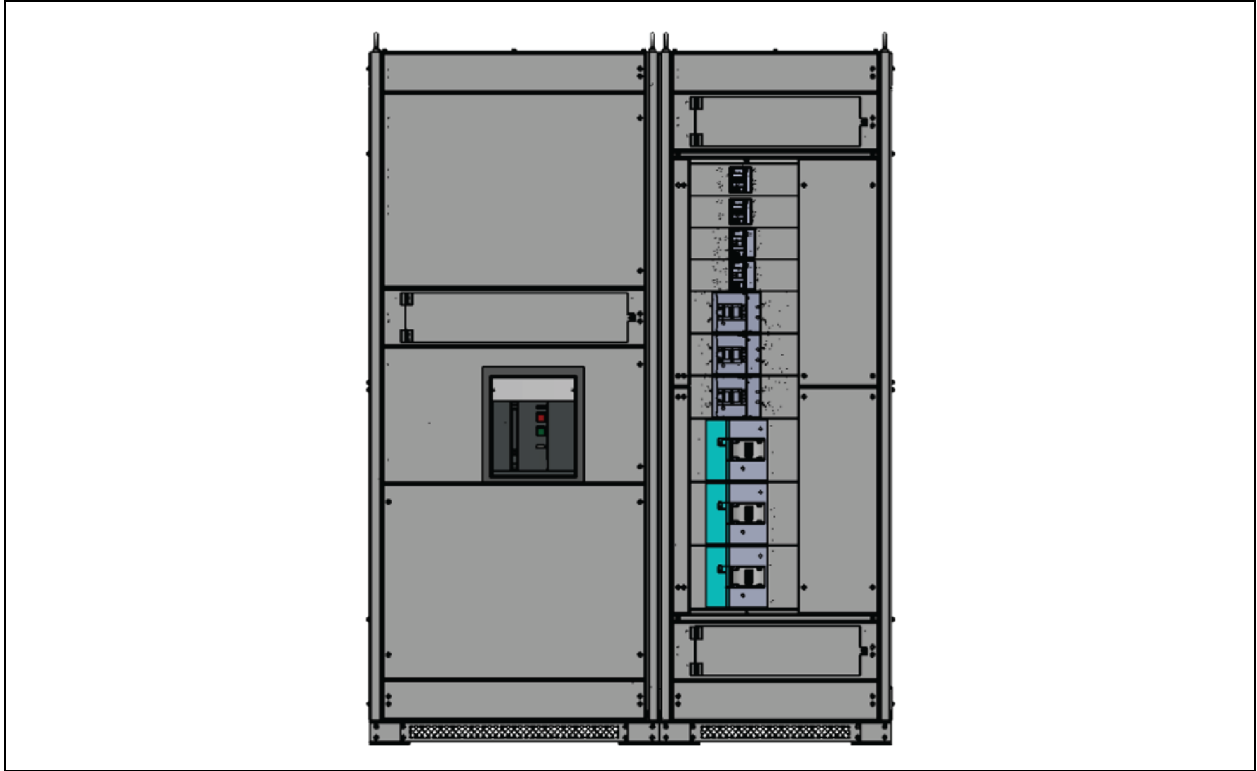

Figure 2.2 Typical Switchboard Rear View

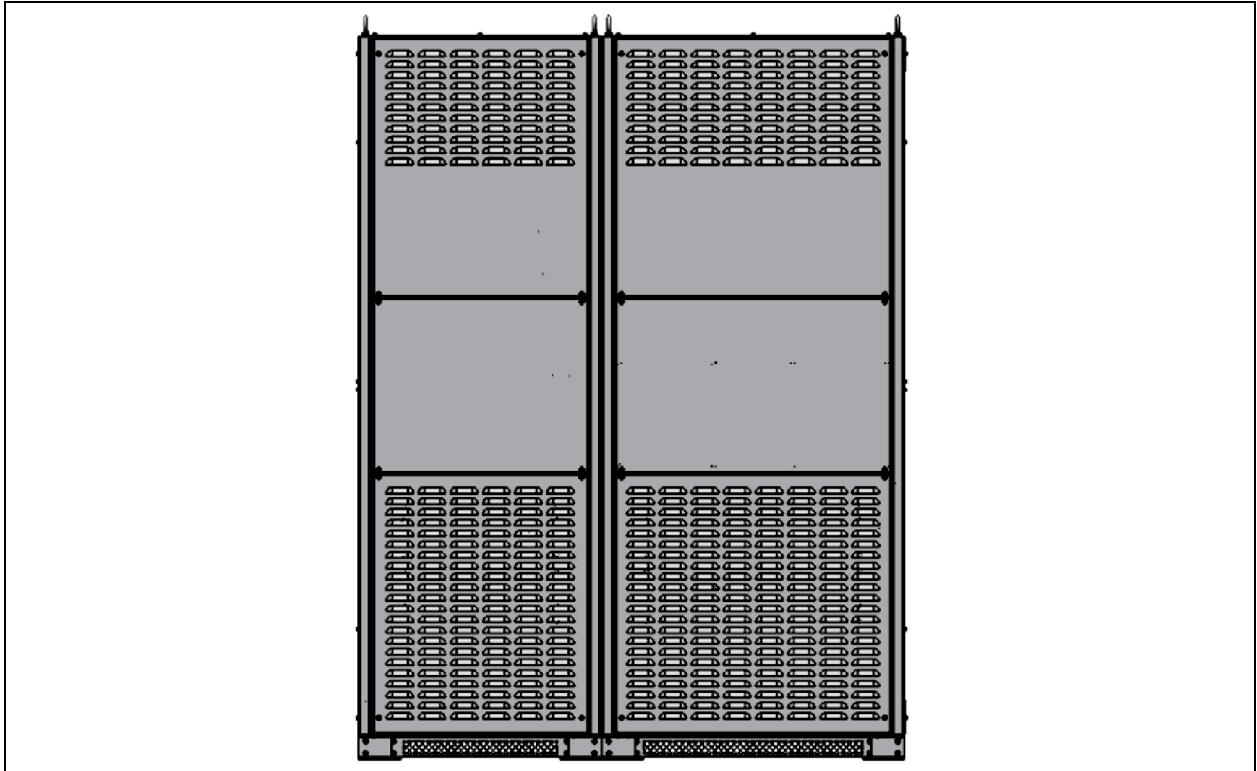
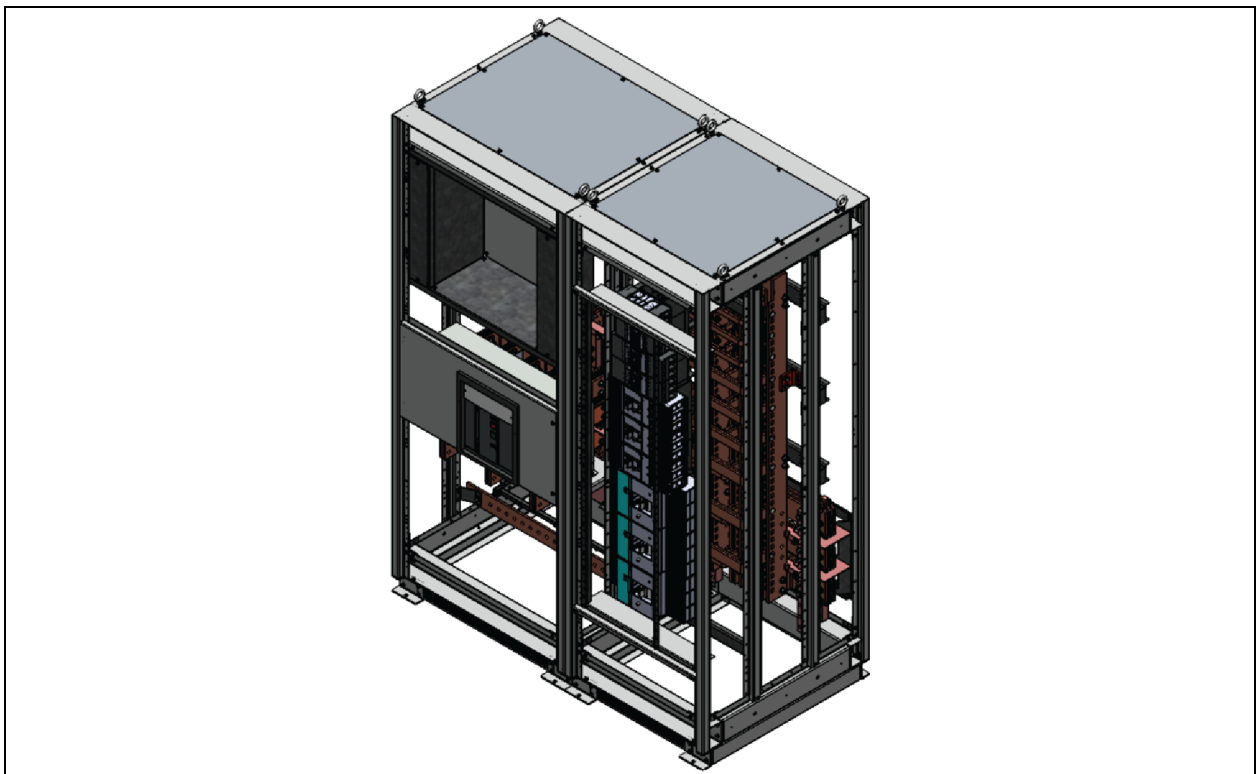

Figure 2.3 Inside View of Switchboard



## 2.3 Design Features and Components

Typical switchboards are available with a variety of options. **Figure 2.4** below and **Figure 2.5** below shows a typical arrangement with components and features for a switchboard.

**Figure 2.4 Rear Internal View**

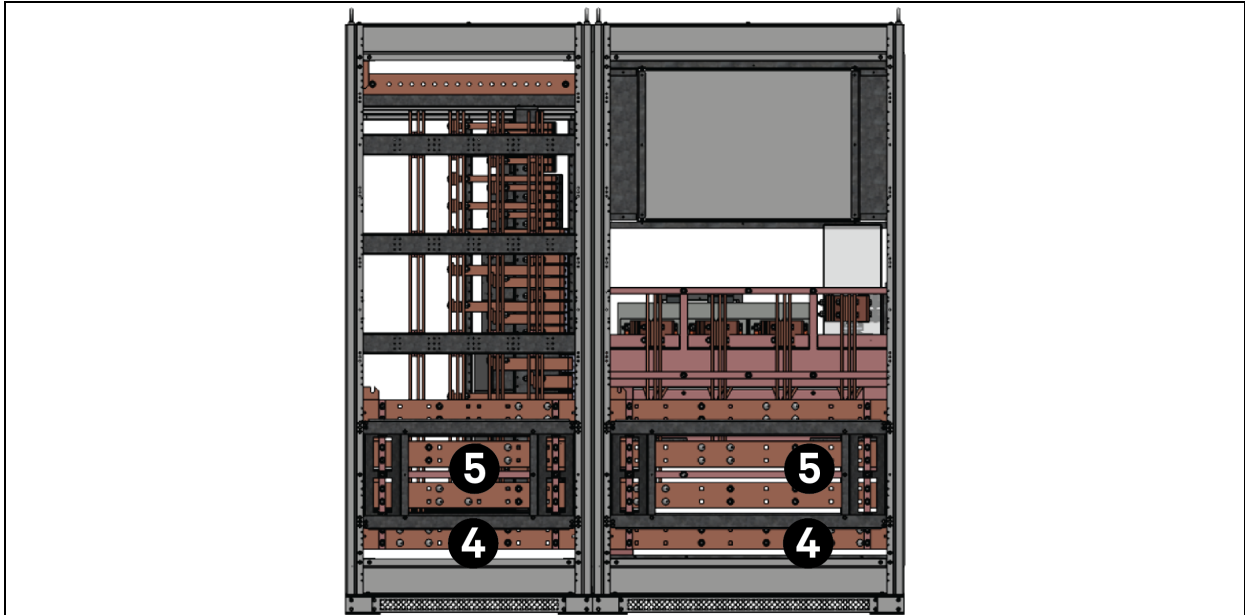

**Figure 2.5 Front Internal View**

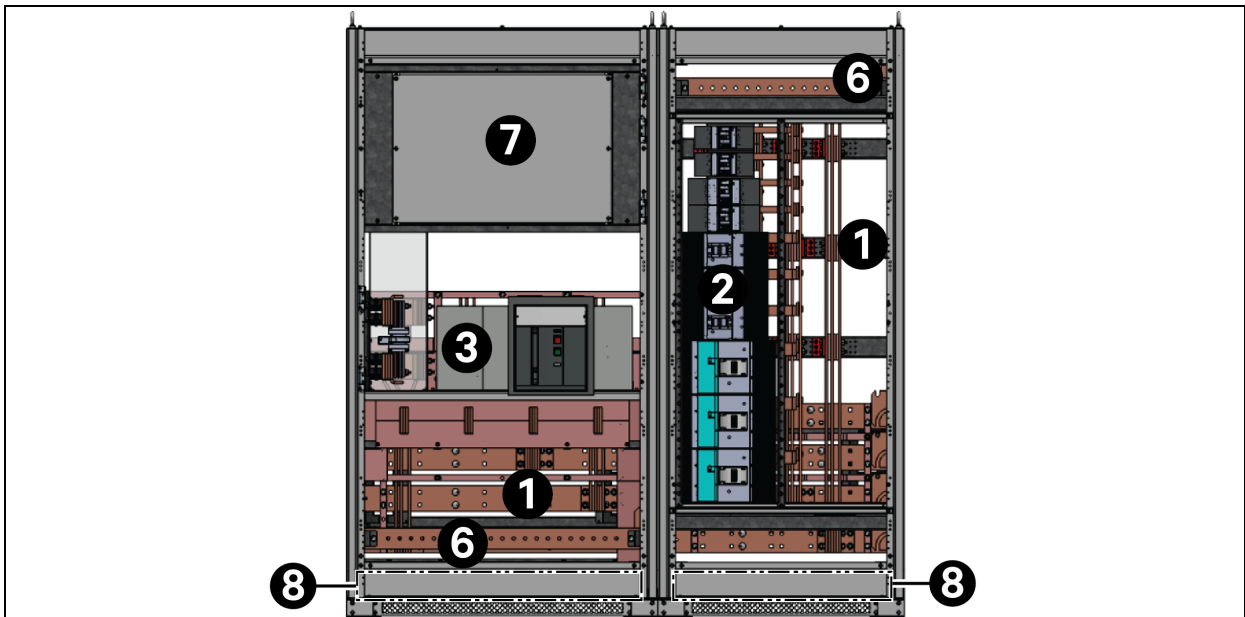

Sr. No.	Item	Description
1	Cableway Compartment	Designated for customer connections.
2	MCCB Stack	Houses MCCB unit(s), designed to break electrical circuit if tripped
3	ACB Compartment	Equipment designed to provide protection for overcurrent and short circuits
4	Neutral Busbar	Voltage difference to each phase is approximately equal in magnitude and are equally spaced in phase.
5	Main Busbar	Carries the majority of the current.
6	Ground Busbar	Ground network for the lineup with taps.
7	Instrument Compartment	Designated as the metering and control section.
8	Bottom Wireway	Designated for control wiring pass through (One set of joining hardware will be stored here per section)

## 2.4 Typical Switchboard Layouts

Switchboards provide typical layouts for ACBs and MCCBs within the lineup. Typical layouts include front accessibility, with single ACBs in individual sections. See **Figure 2.6** below.

Standard MCCB columns with MCCBs stacked on top of each other in individual sections. See **Figure 2.7** on the next page. MCCB's use toggle handles for turning the breakers on and off. Powerboard Go is a front access only switchboard and there is a cable way for field termination.

**Figure 2.6 Typical ACB Layout**

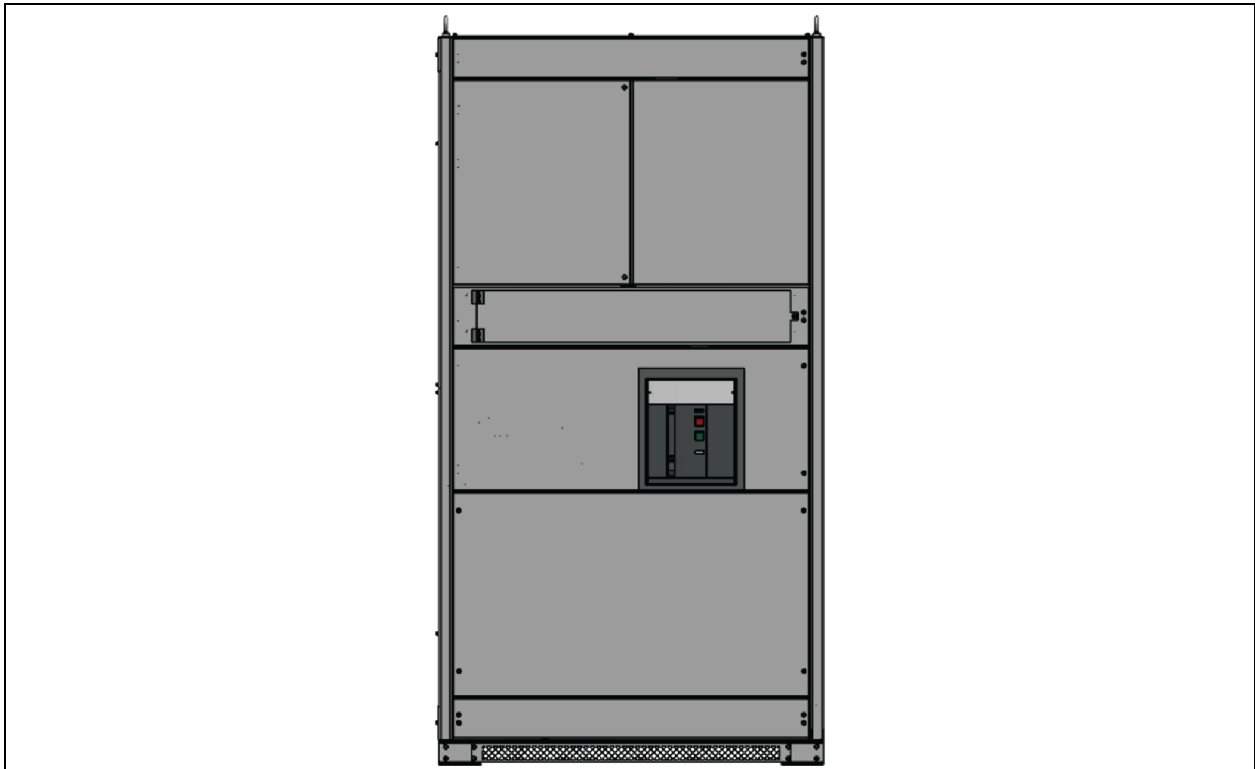
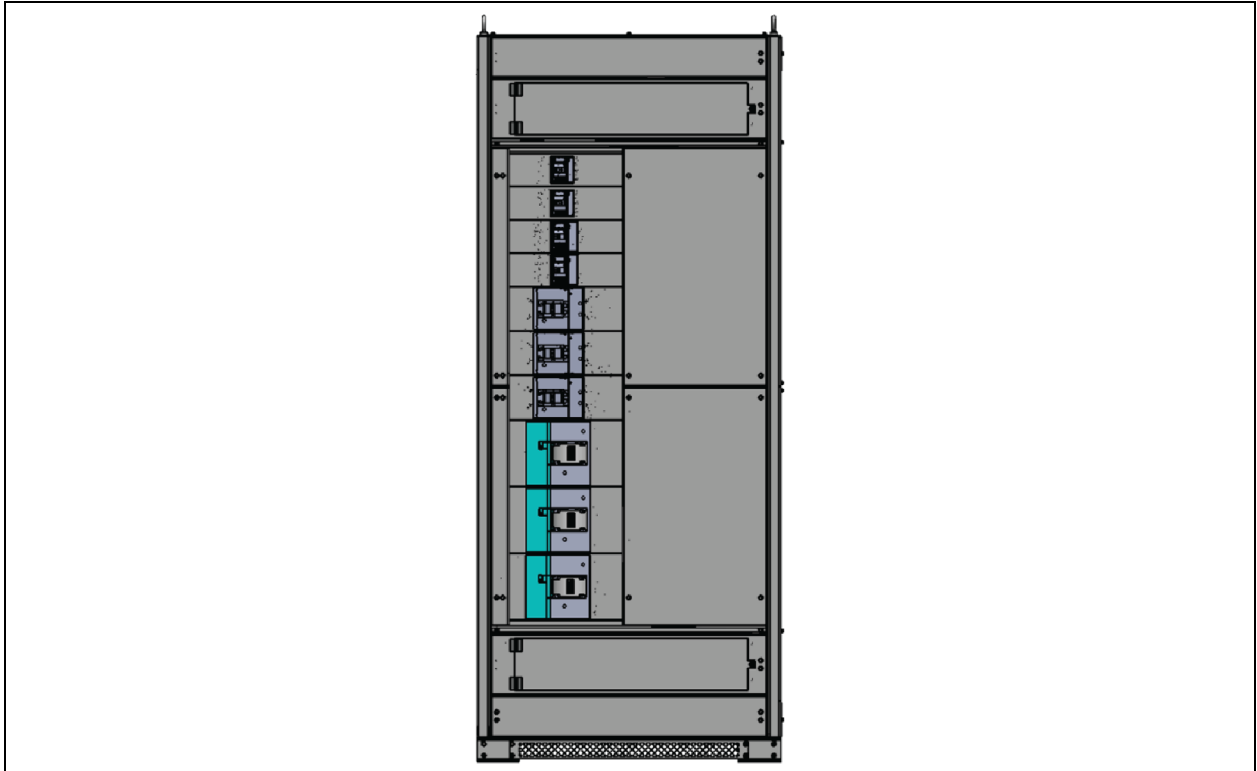

Figure 2.7 Typical MCCB Layout



## 2.5 Typical Customer Connections

Each breaker, either ACB or MCCB, has typical field termination arrangements that are used. **Figure 28** on the facing page is the typical field termination for the different single power breaker or main lug only (MLO) connection. The number of lug provisions changes depending on the nominal breaker rating. All lug pads consist of the standard NEMA hole pattern, which is 1.75 in. x 1.75 in. (44.45 mm x 44.45 mm) with a clearance hole for 0.5 in. (12.7 mm) hardware.

Figure 2.8 Typical Provision for Customer Cable Connections

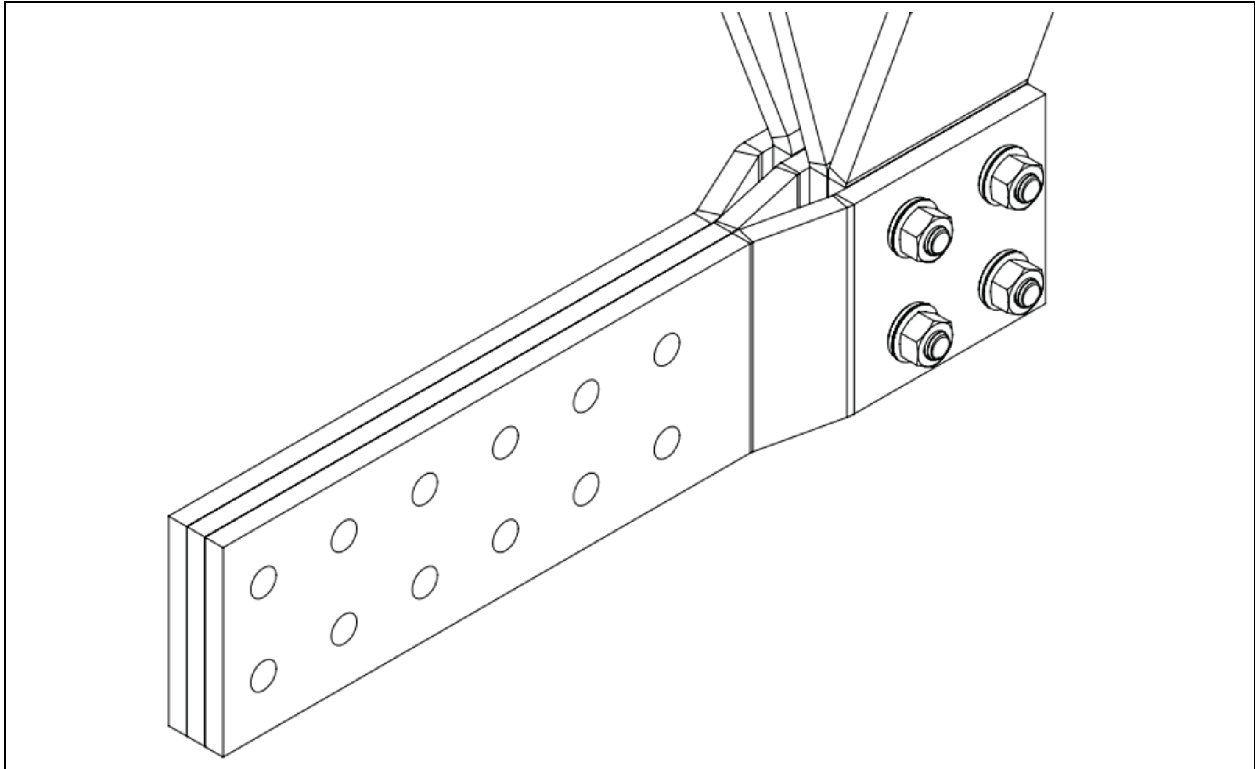

All MCCB customer connections are terminated using the mechanical lug kits that come from the breaker supplier. See **Table 2.1** below shows the number of lug provisions for each circuit breakers and amperage.

**Table 2.1 Breaker Frame Ampere to Cable Provisions per Phase for Each Breaker Type**

Breaker Frame Ampere Rating (A)	Breaker Type	Cable Provisions per Phase
125	MCCB	1
250	MCCB	1
600	MCCB	2
1200	MCCB	4
2500	ACB	10
4000	ACB	12

## 2.6 Typical Ground Layout

The ground is a system that runs the complete length of any switchboard. There are lug provisions throughout the switchboard for field terminations.

**Figure 2.9** on the next page shows the typical arrangements of ground cable provisions per switchboard configuration.

Figure 2.9 Typical Ground Bar Layout

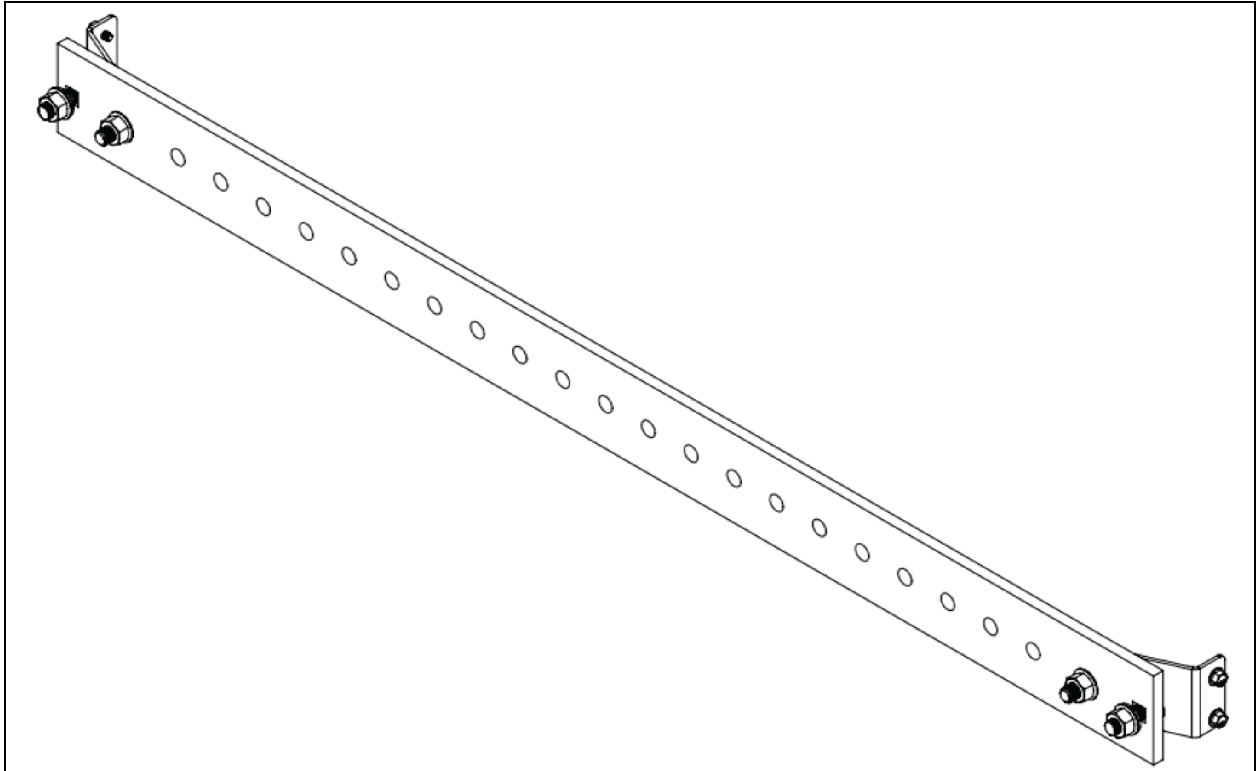

## 2.7 Technical Information

Table 2.2 Typical Specification

Standard		Safety	UL891 - Standard for Safety Switchboards
Test Certificate	-	Switchboard is designed, tested, and certified based on the standard above	E#####
Electrical Data	Rated Voltages	Rated insulation voltage, Vi	1.96 kV
		Rated operating voltage, Ve	Up to 480 VAC
		System types	3-phase 3 wire, 3-phase 4 wire
		Rated frequency	60 Hz
	Rated Ampacities	Rated Current	Up to 4000 A
		Rated short circuit current	Up to 100 kA at 480 V
	Breakers	MCCB	UL489, supplier agnostic
ACB		UL489, supplier agnostic	

Table 2.2 Typical Specification (continued)

Standard	Safety		UL891 - Standard for Safety Switchboards
Mechanical Data	Approx. Dimensions	Height: in (mm)	Up to 92.7 in. (2353 mm)
		Width: in (mm)	Custom per project <b>Main Section:</b> 30.3 in. to 47.7 in. (770 mm to 1212 mm) <b>Distribution Section:</b> 30.3 in. to 37.8 in. (770 mm to 960 mm)
		Depth: in (mm)	Up to 36.5 in. (928 mm)
	Surface Protection	Frame	Paint Finish
		Enclosure	Paint Finish
	Enclosure Type	Type 1 (Front access only)	
	Busbars	Standard - tin plated (Aluminum or Copper)	
		Bus Bracing	Up to 100 kA at 480 V
	Paint finish	Enclosure	Standard – ANSI 61, Gray

## 2.8 Labels and Markings

The switchboard comes standard with a master nameplate located on the main incoming section, as well as several other labels. All nameplates and labels provide information related to the switchboard including and not limited to the switchboard electrical data, cautions and warnings to help the personnel with important information and safety precautions. These labels should be used to verify the supplied switchboard with the requirements for the job site.

Examples of labels that may be found on the switchboard are shown in **Figure 2.10** below.

**Figure 2.10 Typical Labels**

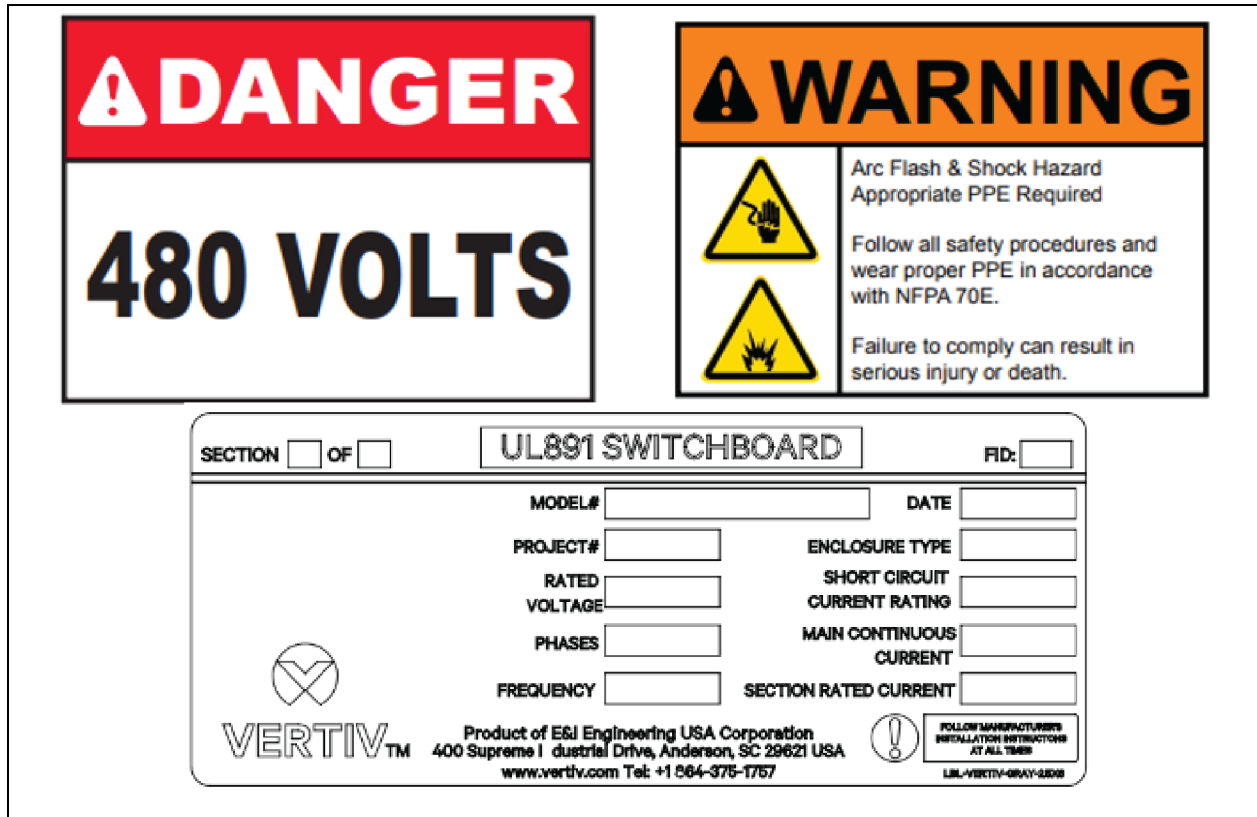

## 3 Packaging and Handling

A Vertiv™ PowerBoard Go switchboard lineup is shipped as a switchboard or in individual section. Unless otherwise requested, the complete switchboard or individual sections will be wrapped and shipped on a pallet to which they are bolted. The pallets are designed for specific section or splits. The standard size of the pallet is the width of the switchboard or section by the depth of the section plus eight inches (approximately four inches in the front and rear of the switchboard when centered on the pallet). Each switchboard is unique to the job; thus the weights vary. For actual weights and dimensions, refer to equipment shipping documentation.

### 3.1 Receiving

- Ensure all sections and splits are present when PowerBoard Go arrives on site. Notify your Vertiv representative if any anomalies are found.
- A thorough inspection should be carried out to make sure no damage occurred during shipment. If damages did occur, a qualified technician needed to investigate the gear for proper diagnosis.
- If the damage is from improper handling, contact the carrier and your Vertiv representative.
- All sections are inspected and marked before they leave the facility. It will be clearly marked with what side is the front, as well as the section or split number.
- A plastic cover should be used to protect the equipment from dust, dirt, moisture, and damage until it is ready for installation. The switchboard should remain attached to the pallet until it has been moved into its final installation position.
- All packaging material should be saved until the gear is ready to be installed, especially if there is a delay in the installation, so that it can be repacked and stored safely. See [Storage](#) on page 14 if a delay occurs.

### 3.2 Handling

Most PowerBoard Go switchboard sections are top and front heavy and should be handled with caution to avoid any potential damage to the components, frame, or finish. Before moving or lifting any section, verify the handling equipment used to handle the switchboard is within the safe limits of its capacity.



**WARNING! Risk of moving heavy unit and tipping over while moving. Can cause equipment damage, personnel injury, or death. The PowerBoard Go is heavy. Make sure that any equipment that will be used to move the system has sufficient lifting capacity.**

#### 3.2.1 Unloading from Truck

A forklift is the best method for unloading the PowerBoard Go switchboard sections.

**IMPORTANT! Only trained personnel should drive the forklift and move the PowerBoard Go. Make sure the ground is solid and all operation and safety recommendations are followed while operating the forklift.**

**NOTE: Be aware of any floors and conditions that could affect stopping and turning. Pay attention to labeling on the packaging material. Make sure that the forklift being used is rated to work at safe limits for the weight of the PowerBoard Go split being lifted.**

1. Lift the switchboard sections from the front or back side.

2. The forks must run all the way through the entire shipping length and extend past the outermost part of the wooden pallet.
3. A safety strap, belt, or leash approved for the purpose of securing the section should be used. Make sure the position of the strap is adequate in providing stability for the equipment, in a location that will not damage any components.
4. Slowly lift the equipment to the minimum required height from the floor for safe relocation.

**Figure 3.1 Forklift**

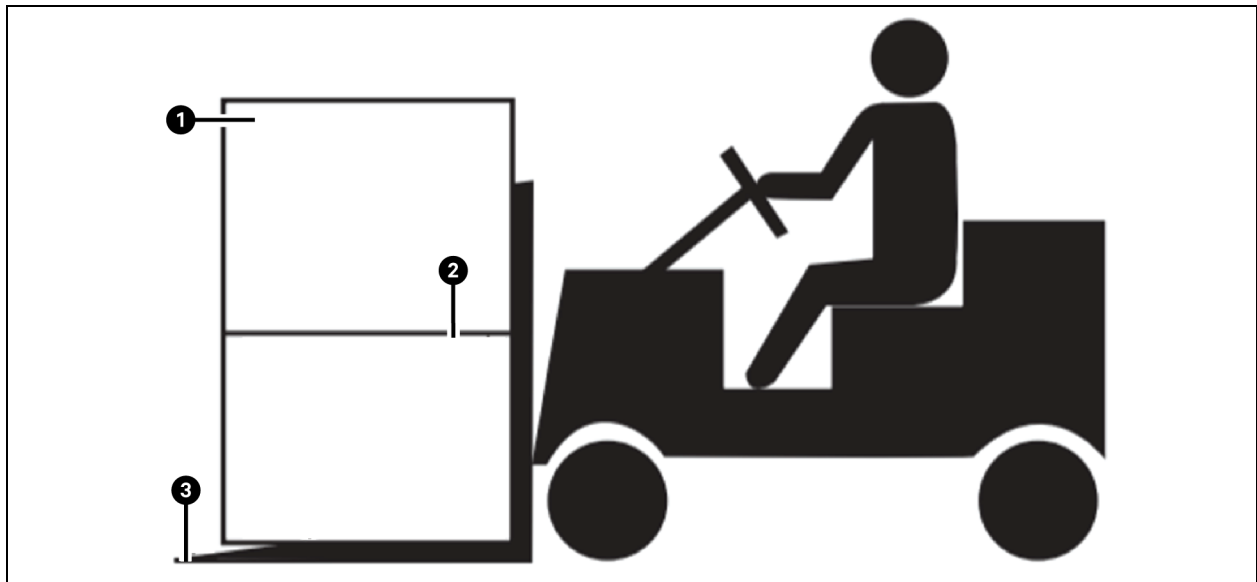

Item	Description
1	Switchboard
2	Secure switchboard to forklift with safety strap here
3	Forks under entire Vertiv™ PowerBoard Go

### 3.2.2 Unloading off Pallet

There are two methods for unloading the PowerBoard Go switchboard sections off the pallet and into the proper installation location. The switchboard sections should be unloaded and placed based on the way the switchboard or section was shipped. Method 1 uses a forklift truck and Method 2 uses overhead hoisting. The procedure for [Method 1: Forklift Truck](#) below and [Method 2: Overhead Hoisting](#) on the facing page are described below.

**NOTE: Vertiv does not provide bars, jacks, skates, straps or spreaders. It is the customers' responsibility to purchase or rent the correctly rated equipment needed to move the panel splits.**

#### Method 1: Forklift Truck

1. Remove the front and rear vented kickplates if installed.
2. Unbolt the switchboard or sections from the designated pallet.

**NOTE: Make sure that the depth of the panel and rear plinth allows fork arms to contact both front and rear plinths. Fork arms must not extend beyond the rear plinth to avoid wall damage during placement.**

3. If the truck forks inserted from the front, protect the front component of switchboard with padding to prevent damage.
4. Insert the truck forks carefully into the front or rear of the switchboard or section.
5. Lift the switchboard or section until it is above the pallet.
6. Move the pallet out from underneath the unit.
7. Install a safety strap, belt, or leash that is specifically approved for securing the switchboard or section. Make sure the strap is positioned so that it does not cause damage to the switchboard or any components.
8. Place the switchboard or section at its designated location and set the unit down on a level surface.
9. Reinstall front and rear vented kickplates after placing the unit.

## Method 2: Overhead Hoisting

1. Make sure all four section eyebolts are installed.
2. Remove the switchboard or section from the designated pallet by unbolting them.
3. Use lifting spreaders, slings, chains, or straps connected to the four eyebolts. Make sure all lifting equipment is rated for the switchboard or section.
4. Lift the switchboard or section until it is above the pallet.
5. Move the pallet out from underneath the unit.
6. Place the switchboard or section at its designated location and set the unit down on a level surface.

**Figure 3.2 Eyebolts Location**

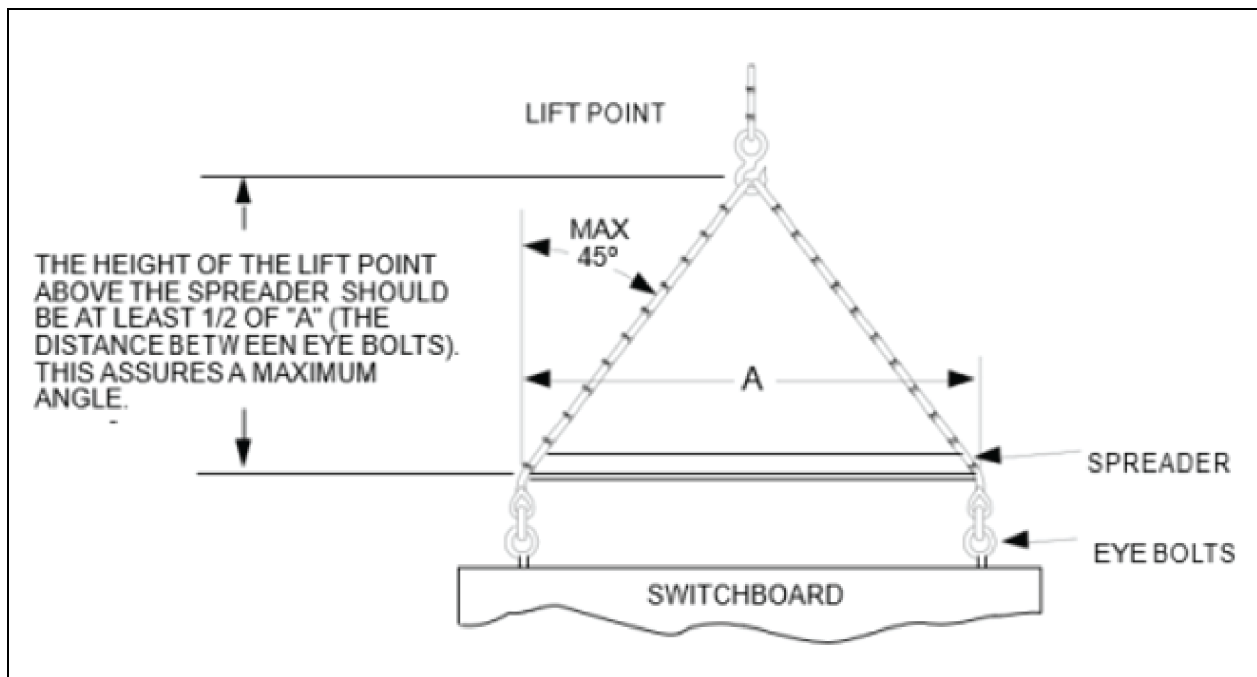

### 3.3 Storage

If delays occur in the installation of the switchboard then:

- It should be properly stored to avoid any type of damage.
- It should be stored in a clean, dry space having a uniform temperature to prevent condensation. Preferably, it should be stored in a heated building that has adequate air circulation and is protected from dirt, fumes, water, and physical damage.
- It is recommended that switchboards should not be stored outdoors. However, if they must be stored outdoors, cover them securely to provide protection from weather and dirt. Temporary electrical heating should be installed to prevent condensation; approximately 250 watts per section is adequate for the average switchboard size and environment. All loose packing or flammable materials inside the switchboard should be removed before energizing space heaters.
- It should be unpacked and examined. See [Receiving](#) on page 11 .
- It should be stored in a location that has less than 60 percent relative humidity and a stable temperature between 32 °F to 104 °F (0 °C to 40 °C).
- Space heaters (if applicable) should be temporarily disconnected from internal connections and powered externally to reduce condensation.
- If the unit is going to be stored for an extended period, the sections and splits should be re-covered in the packaging material or plastic cover to help protect them.

## 4 Installation

Following are the details for the installation of the switchboards.

### 4.1 Pre-Installation Preparation

- Install Vertiv™ PowerBoard Go on a smooth, solid, and level foundation (no more than  $\pm 0.125$  in. (3.175 mm) per 3 ft. (914.4 mm)).
- The altitude of the installation site should be less than or equal to 3280.8 ft. (1000 m).
- An uneven floor can cause issues with installation, with consequences of misaligned sections, units, doors, and other parts.
- Determine the layout of the switchboard.
- Verify that the available equipment space and location follow the minimum working space clearances according to the NEC standards.
- A clearance of at least one inch from the rear of the switchboard to a wall is required.

Pre-Site Visit / Site Readiness Checklist - Installing Contractor (CS-980000-00) provides further guidance to the installation team for a successful switchboard installation.

**NOTE: Refer to the manufacturer's switchboard drawings for the glanding area for conduits. Install the Conduits in the glanding area to ensure compliance with NEC and UL Wire bending requirements.**

### 4.2 Considerations for Installation

Use methods described in [Unloading off Pallet](#) on page 12 to move the switchboard into its final position. Use extreme caution and appropriate practices and equipment when doing so. Refer project documentation for specific center of gravity locations. Switchboards are shipped as a whole or in individual sections that are joined together. Determine the orientation of the switchboard or of each split by the manufacturer drawings and markings on the units. A drawing will provide the splits in order and where they will join. Each section will have a label that states 'SECTION # OF #' (see **Figure 2.10** on page 10). These labels are in either a control or breaker section closest to eye level of an average human.

Most switchboard sections are designed to be front aligned, manufacturer drawings provided will show footprint details. The orientation on the drawings must be maintained as specified.

Switchboard sections may have factory-installed bus and/or cabling to connect power between splits and other components. Installers should note the position and direction of splice plates and/or cables after sections are joined. All splice plates and hardware necessary for completing the connections will be supplied. These components will be installed on the horizontal bus on either end as applicable. All bus materials and hardware should be stored in a clean and protected area to prevent damage before installation. Factory-installed component cables should also remain safeguarded from possible damage during section placement.

### 4.3 Anchoring

The switchboard must be securely bolted to the floor. Make sure that the floor is level and structurally capable of supporting weight and operational demands of the switchboard to maintain proper alignment between sections. To anchor the switchboard, use minimum grade 5 or equivalent, 1/2" diameter wedge or hook anchors equipped with washers and nuts. The anchor bolts should protrude through the floor between 26 mm to 28 mm.

Each switchboard section should be independently installed over the anchors using [Unloading off Pallet](#) on page 12. There are four bolting locations within each switchboard section, as illustrated **Figure 4.1** below, **Figure 4.2** on the facing page and **Table 4.1** on the facing page for layout and dimensions. Each bolt must be torqued according to the specifications mentioned in the **Table 7.1** on page 27.

**NOTE:** Vertiv does not provide anchoring hardware or tools.

**Figure 4.1** Floor or Concrete PAD

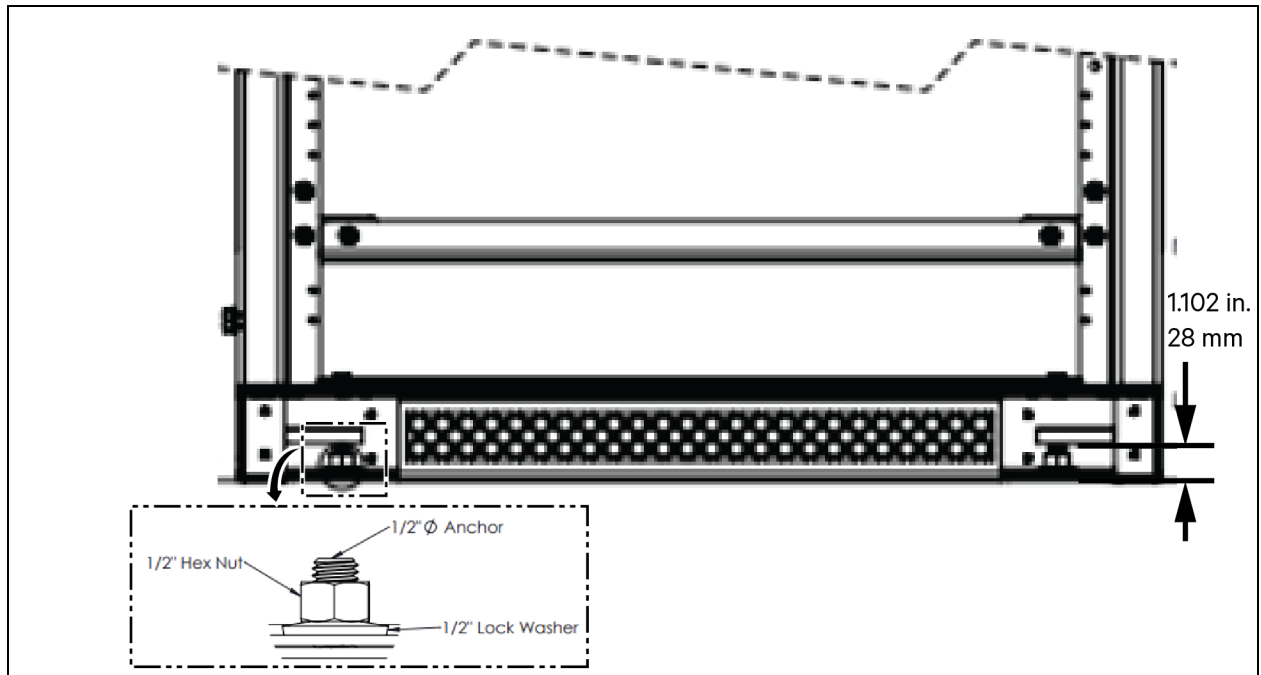

Figure 4.2 Anchoring Detail

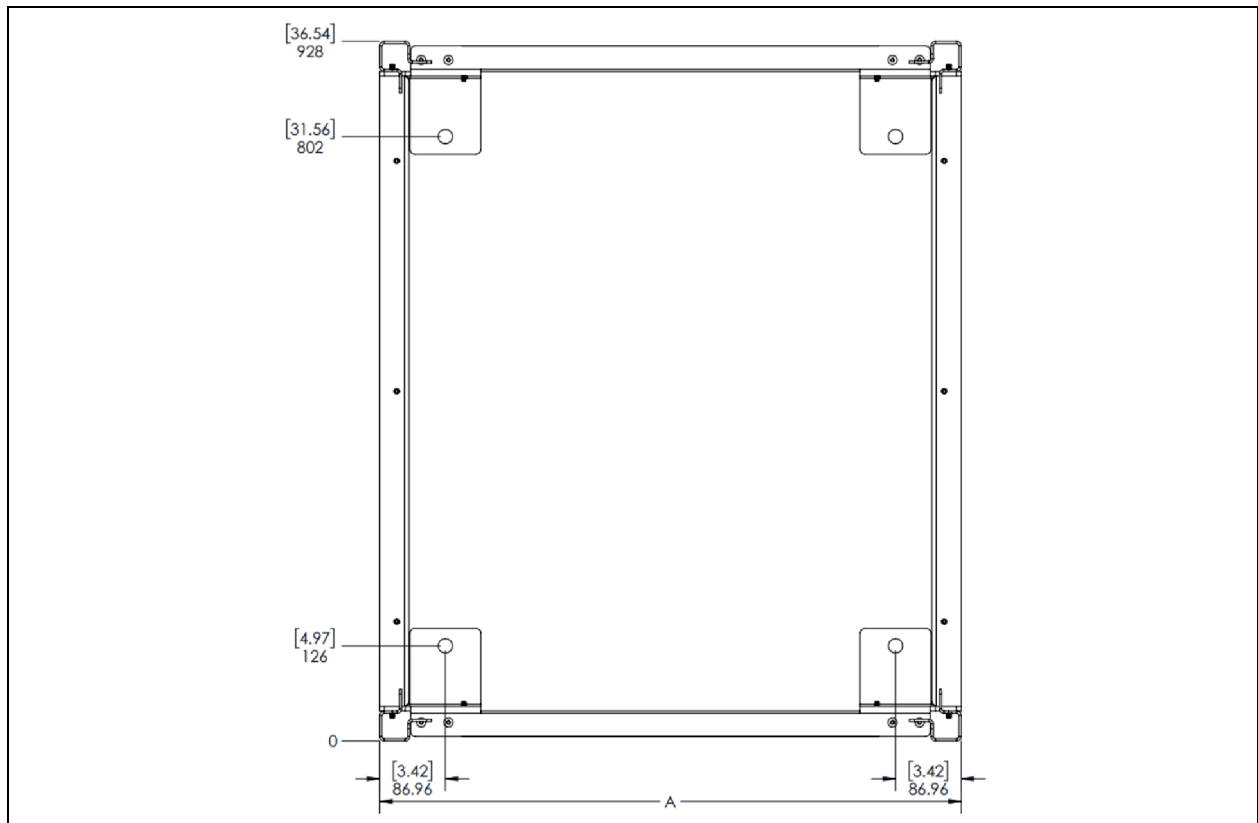
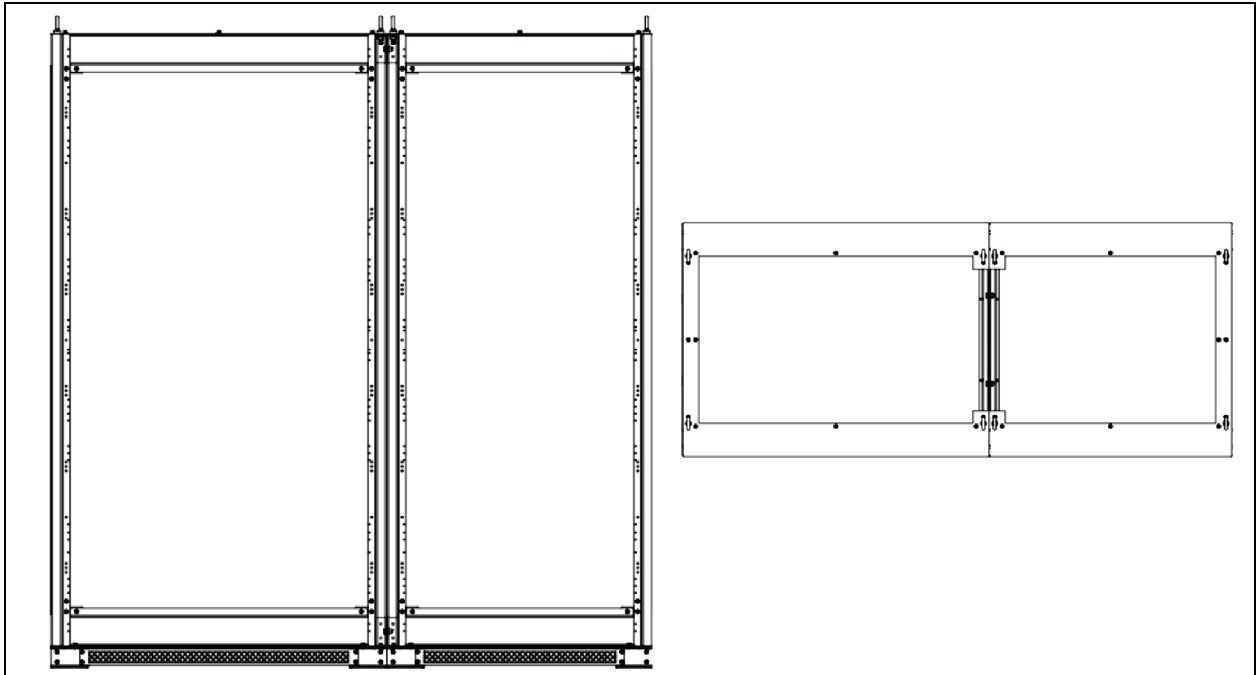
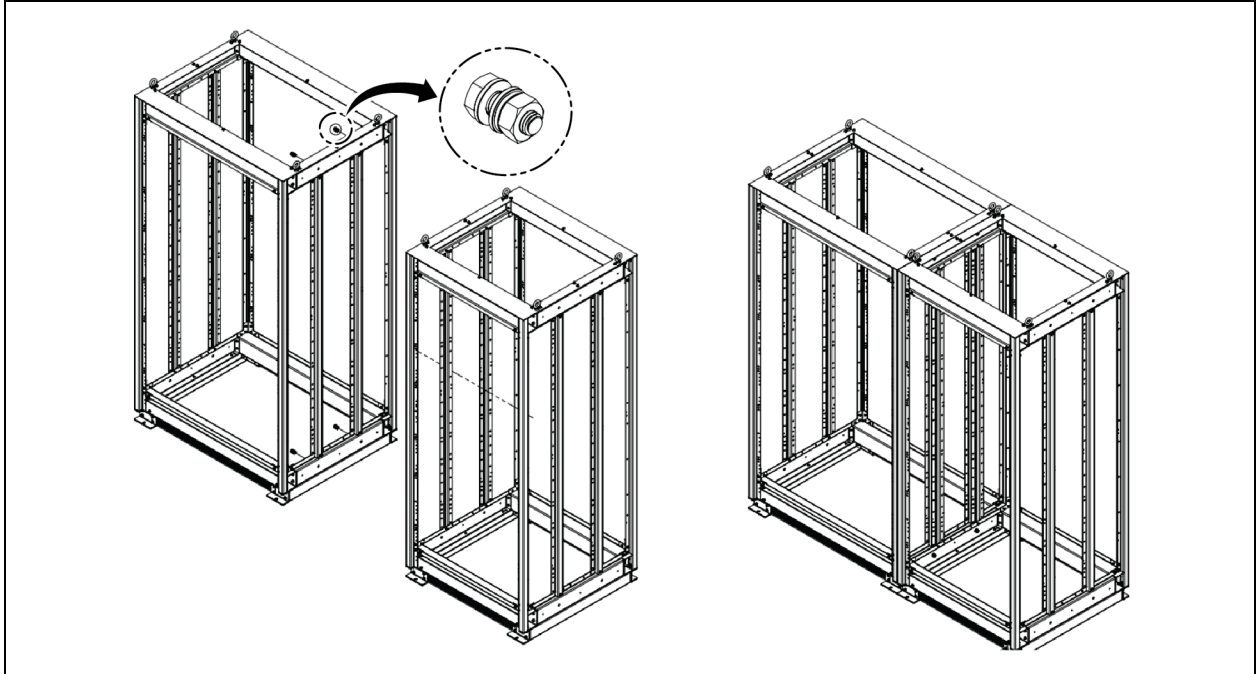

Table 4.1 A Distance

A in. (mm)
30.32 (770)
37.80 (960)
47.72 (1212)

## 4.4 Joining Sections

The manufacturer supplies hardware for connecting the switchboards. The standard hardware includes an M 12 x 40 mm hex head screw, nuts, and washers. Four sets are used per section, with holes located at the top and bottom of each section. While maintaining the structures level and aligned, torque each connection according to the torque values specified in **Table 7.1** on page 27. After joining the switchboard sections, check that no foreign objects are inside. Also check that the clearances for live parts are correct.



#### 4.4.1 Splice Plates

Splice plates are components of the busbar that connect the main horizontal bus linking various sections of the switchboard. Depending on the configuration and alignment of the switchboard, multiple splice plate configurations can be used. The splice plates are tightened in a vertical position for shipping; these plates will need to be loosened and rotated 90 degrees into a horizontal orientation. Tighten the M12 nuts facing the front of the switchboard to the torque specified in **Table 7.1** on page 27.

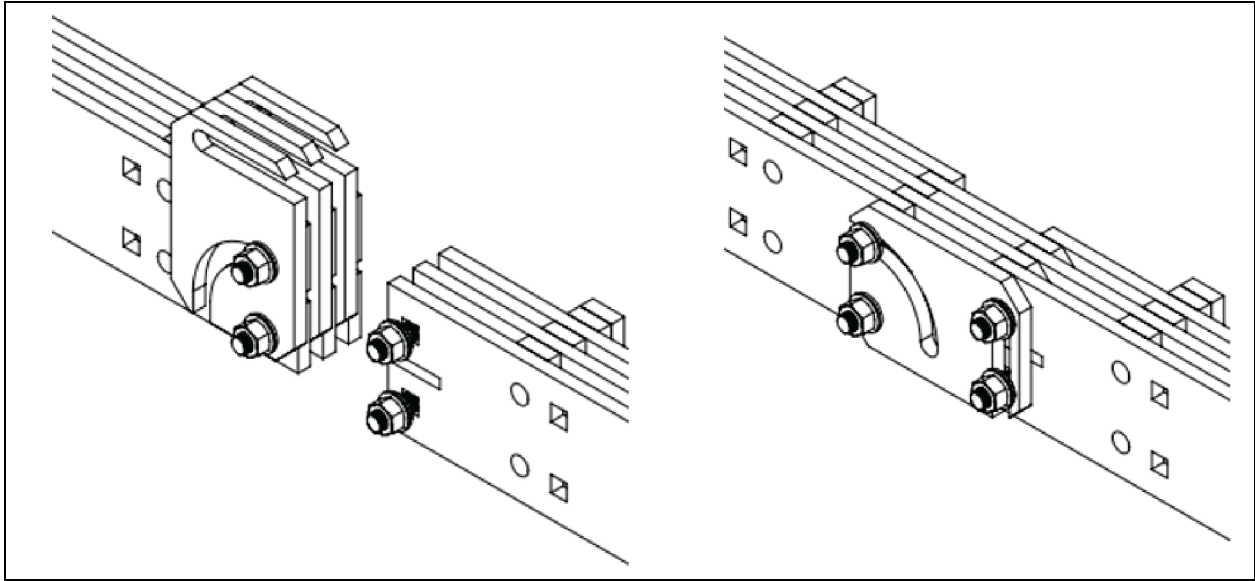
**Figure 4.3 Straight Bus Connection**

#### 4.4.2 Ground Bus Connection

Smaller splice plates, shown in **Figure 4.4** below, are utilized to connect the ground bus at panel splits. These plates are supplied pre-installed in a vertical position within the switchboard section and must be loosened and rotated 90 degrees to achieve a horizontal alignment. When connecting the ground bus, follow the torque specification for M12 as described in **Table 7.1** on page 27.

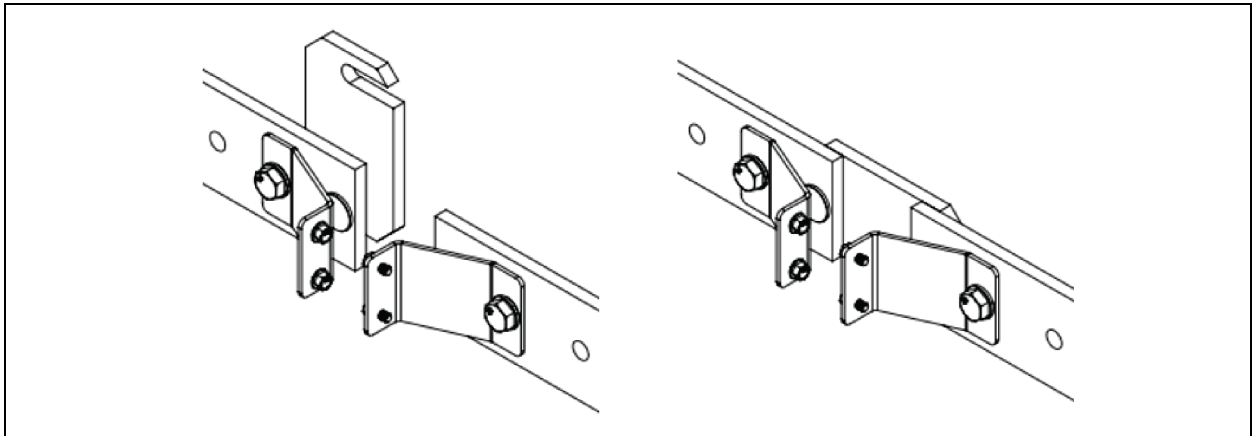
**Figure 4.4 Typical Ground Joining**

### 4.5 Electrical Connections

Various methods are used for making electrical connections in switchboard sections. One or more of these methods may be used within a section and/or across a switchboard lineup, such as bus splice plates and field terminal cabling. Refer to the manufacturer's drawings for specific details. Remove covers and side sheets to access connection points and retain all covers and mounting hardware for reassembly. Make sure that hardware and other components are protected from moisture, debris, and other potential sources of damage.

## 4.6 Cable Connections

Cable connections serve as the primary form of power in and out the switchboard, using mechanical or compression lugs to connect the cable to the provided field termination lug pads (see **Figure 4.5** below).

**NOTE:** Vertiv supplies lug landing pads necessary for mounting cables for single power breaker and main lug only connections. Vertiv supplies MCCB breakers with their associated mechanical lug kits. Any hardware installed on landing pads when received should be removed and discarded.

Refer [Breaker Frame Ampere to Cable Provisions per Phase for Each Breaker Type](#) on page 7 for types or supplied documentation if custom pads are requested. Apply torque settings for hardware as set forth in **Table 7.1** on page 27.

**Figure 4.5 Lug Types**

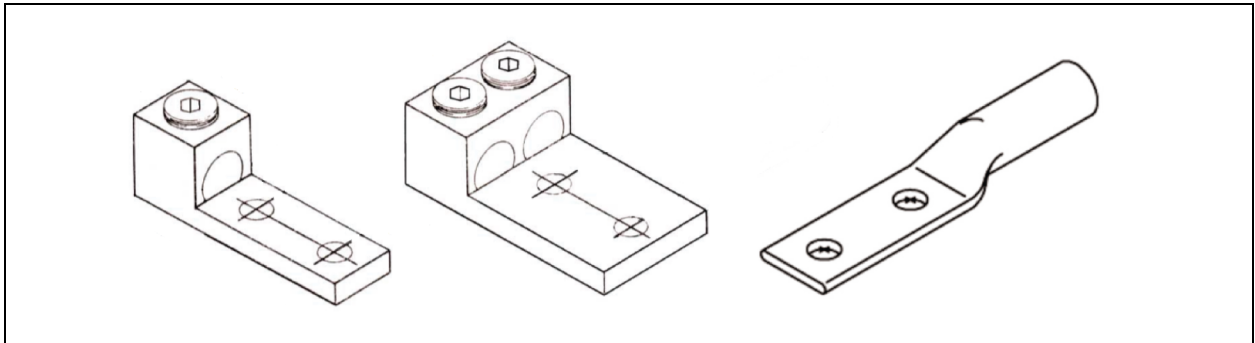

Cables can enter and exit from the top or bottom of the switchboard. Other entry and exit points may be used. These points depends on the basis. Refer to manufacturer's drawings for conduit/glanding areas for the specific project.

**NOTE:** For top entry, the aluminum gland plates must be removed from the panel prior to drilling and punching holes for conduit. Metal shavings in the switchboard poses a hazard to the equipment and dangerous to surrounding personnel when energized.

After securing conduit and cables, bend cables in designated sections, bundle, and label them by phase and neutral if applicable. Avoid forcing insulation against sharp edges to prevent damage; use provided support to secure cables.

Strip cable insulation just enough to fully fill the lug barrel without leaving excess exposed strands. make sure all strands remain intact and equal in length before inserting into the lug. Both mechanical and compression lugs may be used: for ACB or MLO section. Only the MCCB supplied mechanical lugs can be used for connecting cable to the MCCB. Mechanical lugs clamp with set screws, while compression lugs require an approved crimping tool. Attach fixed lugs to the lug pads with specified hardware, tightening to the torque values listed in **Table 7.1** on page 27.

### 4.6.1 Lashing

Cable lashing is required. The process of lashing is laid out below.

Lashing should be performed by bundling the individual line cables and tap cables together using nominal 0.375 in. (9.525 mm) nylon rope (or rope having a minimum tensile strength of 2000 lbs (907.1847 kg)) at 6 in. (152.4 mm), and then after every 12 in. (304.8 mm), see **Figure 4.6** on the facing page.

Figure 4.6 Typical Lashing Details

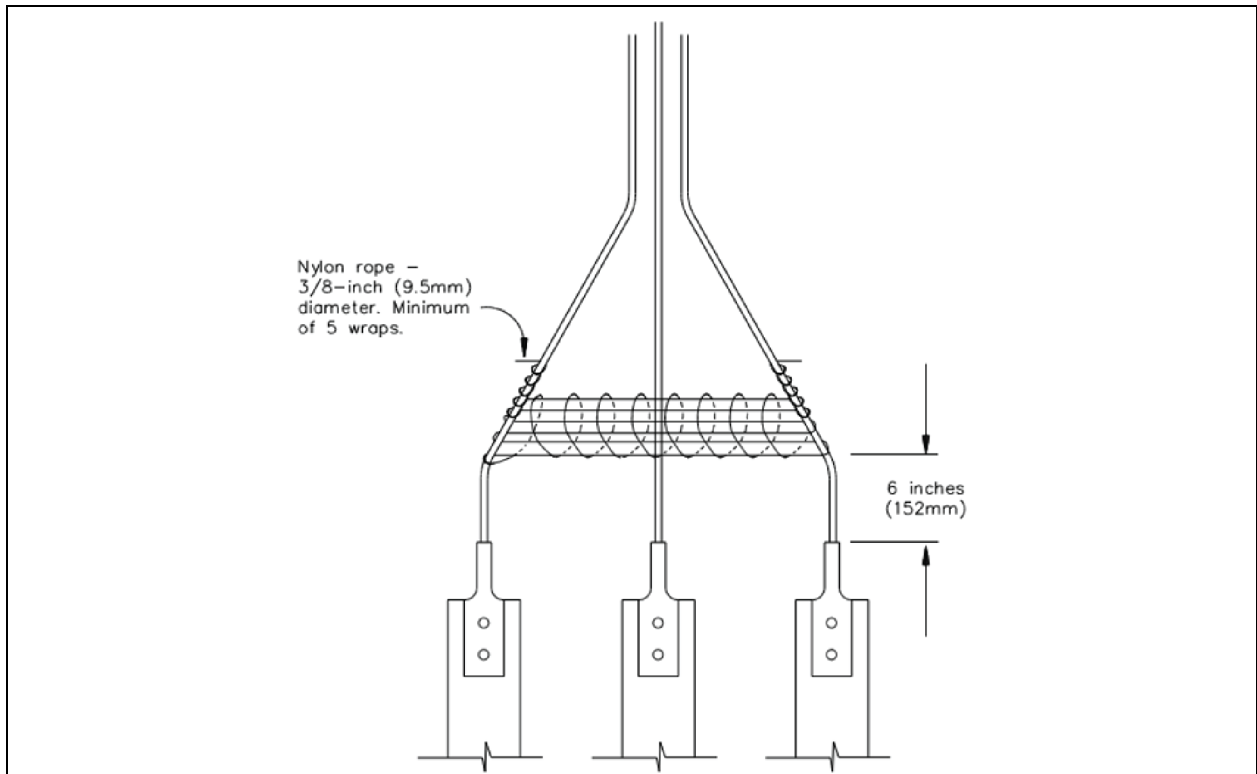

This page intentionally left blank

## 5 Energization

### 5.1 Pre-Energization

Before energizing any switchboard, a comprehensive inspection should be performed.

Ensure of the following checks:

1. Make sure there are no openings larger than 12 mm (for example an MCCB that was never installed).
2. Install all hardware needed to join the sections.
3. Keep enough clearance space as required by the NEC.
4. Remove or isolate any hazards near the area.
5. All the shipping splits are connected and secured to the floor.
6. All splice plates are installed and torqued.
7. All accessible electrical connections are torqued described in **Table 7.1** on page 27.
8. All bus mounting means are intact.
9. The enclosure has not been damaged such that required electrical spacing has been compromised.
10. The switchboard is clean and free from any dust, dirt, or contamination.
11. All gland/conduit plates are installed and secured to the switchboard.
12. The switchboard is grounded appropriately.
13. All circuit breakers are installed, if applicable.
14. All circuit breakers are manually exercised to ensure they operate freely and properly.
15. All covers and doors are installed, closed, and locked, if applicable.

#### 5.1.1 Pre-Energization Tests

Prior to energization, the following tests must be performed on the switchboard, with all the breakers installed and closed, and all control fuses/circuit breakers removed or open. For breakers with metering kits or options, remove or otherwise disconnect the feature from the bus. Surge protection devices must be isolated.

- Continuity checks of the main power circuit (it is advised to use a high-resolution resistance tester and record the results, as these results can be compared during each service interval and any anomalies can be investigated).
- Insulation resistance test.

**NOTE: Do this test before connecting cables to the equipment. If cables are already connected, isolate the test to the internal bus by disconnecting external feeders.**

Once these tests are complete, the switchboard can be returned to its normal state with all control fuses/circuit breakers installed or closed. The switchboard is now ready for energization.

#### 5.1.2 Energization or Startup



**WARNING! Hazardous voltages in electrical equipment can cause severe personal injury or death. Energizing a switchboard for the first time after initial installation or maintenance is potentially dangerous.**

Only qualified personnel wearing the proper PPE should energize the switchboard. Serious injury and damage can occur when the power is turned on due to short circuit conditions caused by damage, poor installation practices, or loose conductive material in the switchboard if not detected during the procedures described in Pre-energization and Pre-energization Tests. Ensure there is no load on the switchboard as it is being energized. The switchboard should be energized in sequence starting at the source end and working to the load end. The main device should be closed first, then all feeder devices, and then any branch circuit devices. These should all be energized one at a time as no issues are encountered.

## 6 Maintenance

Maintenance is critical, but for trouble free operation and long service life of equipment, regular maintenance should be performed on the switchboard and carried out by competent, trained personnel wearing proper PPE. During maintenance, follow the local authority jurisdiction and/ or individual facility procedures to properly lockout/tagout the equipment.

### 6.1 Setting Up a Maintenance Schedule

- It is highly recommended to set a maintenance schedule for the switchboard.
- Note the usage of the equipment and determine how often maintenance should be performed. This should typically be done once a year or after any short circuit.
- Before performing any maintenance make sure the power is turned off and all breakers are de-energized or opened.
- Ensure dead front temperatures are safe to touch before starting any work, if the switchboard had been carrying its regular load for at least three hours prior to inspection.
- Ensure that OSHA approved solvents comply with local regulations are used for cleaning.
- The solvent should be non-flammable, with a threshold limit of 300 PPM or higher.
- Safety-related work practices per NFPA 70E should be always followed.
- Ensure no cleaning materials or tools are left in the equipment and that no components have been damaged before energization.

### 6.2 Maintenance Inspections

Maintenance inspections should be performed on the switchboard and accessories periodically, depending on the maintenance schedule established by the end user. Perform visual and physical inspections to ensure the working conditions of the equipment.

Below are the visual and physical inspections that should be performed.

1. Visual – Proper operation of all indicators, meters, and instruments.
2. Physical – All bolted covers are properly secured.
3. Visual – Proper operation of heaters and thermostats, if available.
4. Physical – Check all bolt connections to ensure the correct fitment. If discoloration or corrosion exist, then there may be an overheated connection.
5. Physical/Visual – Make sure all cables are tightly secured and supported.
6. Visual – Look for signs of wear and tear on control wiring. Wire should be replaced if uncertain.
7. Physical – Clean the equipment by wiping all areas with a clean cloth or the use of compressed dry air.

Other than the stated above, maintenance should be carried out on all individual devices and instruments, according to the specific maintenance requirements laid down by the component manufacturer or device manufacturer. This includes and is not limited to the low voltage circuit breakers, instruments, indicators, meters, and any other possible components that are installed within the equipment. Contact Vertiv representative for maintenance program options.

This page intentionally left blank

## 7 Torque Table

All mechanical parts within the equipment are assigned torque value. The **Table 7.1** below specifies the required torque values for each size of bolt, unless otherwise specified. All mechanical parts come pre-marked and torqued to the values below. If the hardware is not marked or specified below, then it is understood that hand tight capacity, which on average is 2 ft-lbs (3 Nm), is acceptable. There are several components within the switchboard that have their own required torque values. The individual installation/maintenance guide for those components should be referenced for torque identification of those items.

**Table 7.1 Torque Values**

Bolt Size	Standard (ft-lbs)	Metric (Nm)
M6	6	8
0.375 in.	16	22
M10	29	39
M12	40.5	55
0.5 in.		

This page intentionally left blank

# Appendices

## Appendix A: Technical Support and Contacts

### A.1 Technical Support/Service in the United States

Vertiv Group Corporation

24x7 dispatch of and technical support for all products.

1-800-543-2378

### A.2 Locations

United States

Vertiv Headquarters

505 N Cleveland Ave

Westerville, OH 43082

## Appendix B: Warranties and Liabilities

This manual does not imply any understanding, agreements, representations, or warranties, other than what is specifically set forth by an existing contract between purchaser and seller. Any such contract will state the entire obligation of the seller. The Installer/User Guide shall not become a part of or modify any possible agreement, commitment, or relationship between the two parties.

This Installer/User Guide is based solely on Vertiv's experience with the switchboard including all information, recommendations, descriptions, and safety notions within this document. Thus, anything in this manual shall not be considered all-inclusive or covering all contingencies.

No warranties, expressed or implied, including warranties of fitness for a particular purpose or merchantability, or warranties arising from course of dealing or usage of trade, are made regarding the information, recommendations, descriptions, and safety comments contained herein.

In no event will Vertiv be responsible to the purchaser or user in contract, in tort (including negligence), strict liability or otherwise for any special, indirect, incidental or consequential damage or loss whatsoever, including but not limited to damage to or loss of use of equipment, plant or power system, cost of capital, loss of profits or revenue, cost of replacement power, additional expenses in the use of existing power facilities, or claims against the purchaser or user by its customers resulting from the use of information, recommendations, descriptions and safety comments contained herein.

### **Connect with Vertiv on Social Media**



<https://www.facebook.com/vertiv/>



<https://www.instagram.com/vertiv/>



<https://www.linkedin.com/company/vertiv/>



<https://www.x.com/Vertiv/>



---

Vertiv.com | Vertiv Headquarters, 505 N Cleveland Ave, Westerville, OH 43082 USA

©2025 Vertiv Group Corp. All rights reserved. Vertiv™ and the Vertiv logo are trademarks or registered trademarks of Vertiv Group Corp. All other names and logos referred to are trade names, trademarks or registered trademarks of their respective owners. While every precaution has been taken to ensure accuracy and completeness here, Vertiv Group Corp. assumes no responsibility, and disclaims all liability, for damages resulting from use of this information or for any errors or omissions.

SL-80072\_REVA\_11-25