



Liebert® HPC-W WH-series Water-Cooled chiller with Screw Compressors

DATA4 WAW01 DC02

User Manual

English, 10071777MAN_ENG, rev. B - 10.06.2025

This document, written in English, is the original version

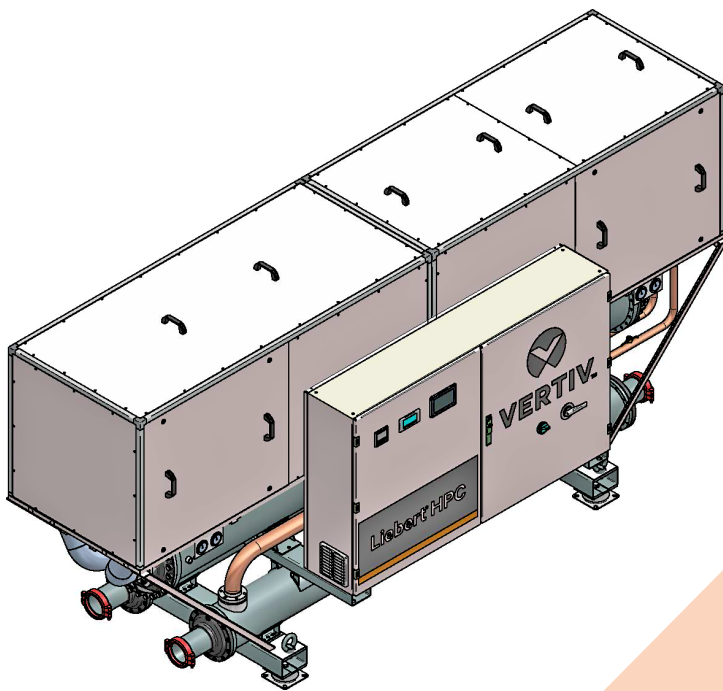

SAVE THESE INSTRUCTIONS

Contents

1. Safety	1	8.3 Installation Site	28
1.1 Conventions	1	8.4 Water System Specifications	29
1.2 General Instructions	1	8.5 Electric System Specifications	33
1.3 Electric System	2	8.6 Positioning	34
1.4 Personal Protective Equipment	2	8.7 Connections	35
2. Digit Nomenclature	3	8.8 Filling the Water System	38
3. Intended Use	4	8.9 Initial Checks	38
3.1 Functional Limits	4	9. Operation	39
3.2 Operating Environment	4	9.1 Safety Instructions	39
3.3 Space Limits	4	9.2 Power-up	39
4. Reference Norms	5	9.3 Preparation	40
5. Description	6	9.4 Start	40
5.1 Versions	6	9.5 Check the Operation	41
5.2 Structure	7	9.6 Stop	41
5.3 Refrigerating System	8	9.7 Restart	41
5.4 Water System	13	10. Maintenance	42
5.5 Electric System	15	10.1 Safety Instructions	42
5.6 Control System	16	10.2 Safety Labels	43
5.7 Special Instrumentation	18	10.3 Spare parts	43
5.8 Accessories	19	10.4 Maintenance programme	43
6. Technical Data and Performances	20	10.5 Panels Opening (Low Noise Version)	44
6.1 Refrigerating System	20	10.6 Refrigeration System	45
6.2 Water System	20	10.7 Calibrations	48
6.3 Operating Limits	22	10.8 Water System	49
6.4 Electrical System	22	11. Troubleshooting	50
6.5 Noise Level	23	12. Dismantling the Unit	51
7. Handling	24	12.1 Safety Instructions	51
7.1 Safety Instructions	24	12.2 Operations	52
7.2 Inspection	24	13. Regulation (EU) no. 517/2014 (F- gas) ...	53
7.3 Storage	24	13.1 Introduction	53
7.4 Transport (with or without Package)	25	13.2 Normative References	53
7.5 Unpacking	25	13.3 Fluorinated Greenhouse Gases	53
8. Installation	26	13.4 Operators	54
8.1 Overview	26	13.5 Leakage Detection	54
8.2 Safety Instructions	27	13.6 Labelling	55
		13.7 Record Keeping	55

Annexes

Annex I – Dimensions and Weights	57
Annex II – Refrigerating Circuit	58
Annex III – Safety Labels	61

Documents supplied with the machine

- User Manual (this document)
- Vertiv™ iCOM3™ User Manual
- Electric Diagrams
- Refrigerant and Hydraulic Diagrams
- CE – PED declaration of conformity
- Instruction Leaflet for Transport and Handling (on the packaging)
- Warranty Certificate

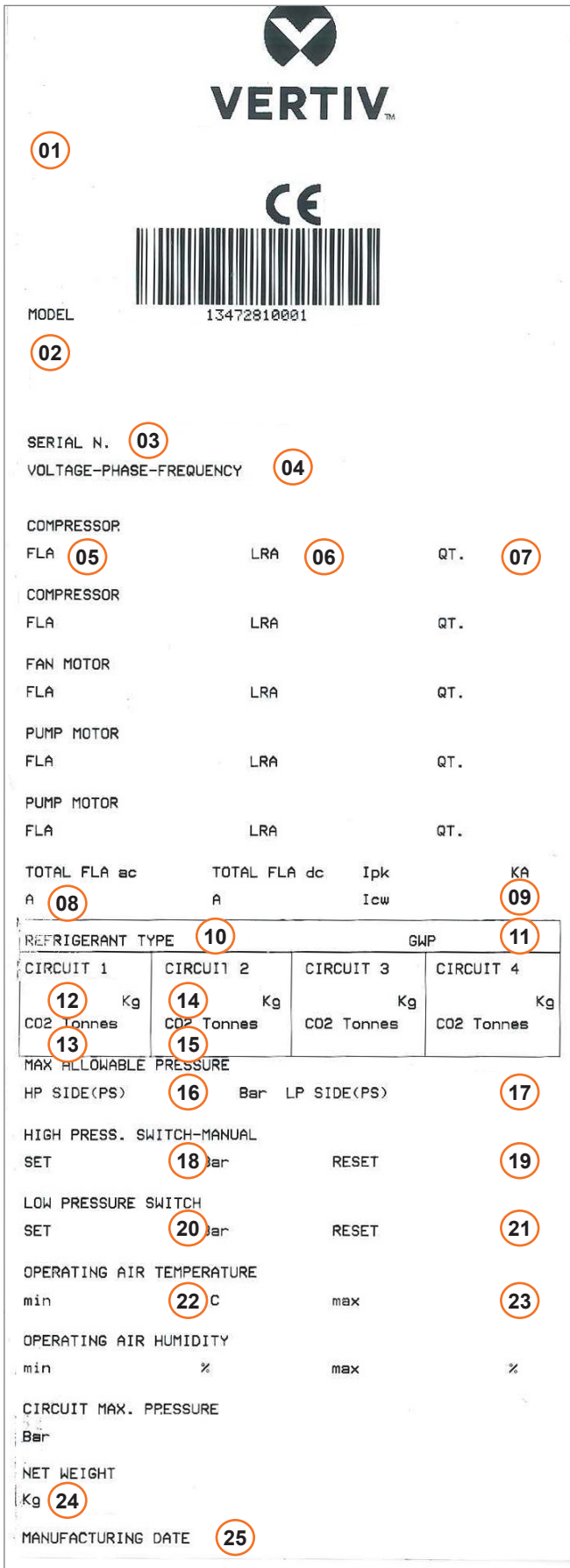

Onboard Label

Please refer to the label placed on the unit for the relevant operating data.

If you need assistance or spare parts, please find the model identification and the serial number on the label.



NOTICE

The data in the manual are referred to standard conditions and can be modified without any advance notice.

The data relevant to the supplied unit are filled in the inboard label (see below an empty facsimile).

Pos.	Description
01	Manufacturing plant
02	Model
03	Serial number
04	Power input
05	Circuit 1 - Compressor Full Load Ampere
06	Circuit 1 - Compressor Locked Rotor Ampere
07	Circuit 1 - Compressor quantity
08	Unit Total Full Load Ampere AC [A]
09	Rated Short-Time Current [kA]
10	Refrigerant type
11	Refrigerant GWP
12	Circuit 1 - Refrigerant charge on factory
13	Circuit 1 - Refrigerant charge CO ₂ tonnes
14	Circuit 2 - Refrigerant charge on factory
15	Circuit 2 - Refrigerant charge CO ₂ tonnes
16	Max allowable pressure - High pressure side
17	Max allowable pressure - Low pressure side
18	High pressure switch - Stop
19	High pressure switch - Restart
20	Low pressure switch - Stop
21	Low pressure switch - Restart
22	Min. room operation temperature
23	Max. room operation temperature
24	Net weight
25	Manufacturing date

1. Safety

This chapter gives general safety instructions.

Additional safety warnings, for specific operations, are given in the rest of the manual.

1.1 Conventions



DANGER - Indicates a hazardous situation which, if not avoided, **will** result in death or serious injury.
WARNING - Indicates a hazardous situation which, if not avoided, **could** result in death or serious injury.
CAUTION - Indicates a hazardous situation which, if not avoided, **may** result in minor or moderate injury



NOTICE
 Indicates a property damage message



ENVIRONMENT
 Indicates a environment damage message



WARNING
 Low Burning velocity gas

1.2 General Instructions

Intended readers	This User Manual is intended for transport, installation and maintenance personnel. The end user can only switch the unit ON and OFF (see <i>Electric box and main switch</i>)
Authorized personnel	The operations described in this manual must be made by technical staff, expressly authorized in compliance with the regulations in force at the installation site.
Read this manual	Carefully read the manual before performing any operation on the unit.
Keep this manual	Keep the manual during the complete life-span of the unit. Keep the diagrams provided with the unit (wiring, refrigerating circuit, ...). They are part of the instructions for use. If you move or sell the unit, transfer the manual and the diagrams together with the unit. This manual may be subject to modification. For complete and up-to-date information always consult the manual supplied with the machine.
Intended use	Exclusively employ the unit for the purpose it has been designed (see <i>Intended Use</i>). The improper use of the unit exonerates the manufacturer of any responsibility.
Do not modify the unit	Do not modify the unit in any way, including the control system and the software. Any modification to the unit exonerates the manufacturer of any responsibility.
Warning labels	Pay attention to the warning labels on the unit. See <i>Annex III – Safety Labels</i> for the mapping of the safety labels placed on the unit.

1.3 Electric System



WARNING

Unit contains potentially lethal voltage in some circuits.

Risk of arc flash and electric shock. Can cause injury or death.

- Open all local and remote unit electric power disconnect switches, verify with a voltmeter that power is **OFF** and wear protective equipment per local standard before working within the electric control enclosure.
- The panel key supplied with the unit must be kept by the person responsible for maintenance.



WARNING

The electric and control enclosures can retain a stored high-voltage electrical charge for up to **10** minutes.

Risk of electric shock. Can cause serious injury or death.

Before working within the unit electric and control enclosures proceed as follows:

- open all local and remote unit electric power disconnect switches
- wait **10** minutes
- verify with a voltmeter that power is **OFF**

Only properly trained and qualified personnel may perform repair, maintenance and cleaning.

1.4 Personal Protective Equipment

As a general rule, always wear the following **PPE** (Personal Protective Equipment):



CAUTION

Components at high temperature (discharge line and compressor at about 120°C).

Always wear temperature resistant gloves when operating on the unit.

2. Digit Nomenclature

The unit is fully defined by twenty five digits.

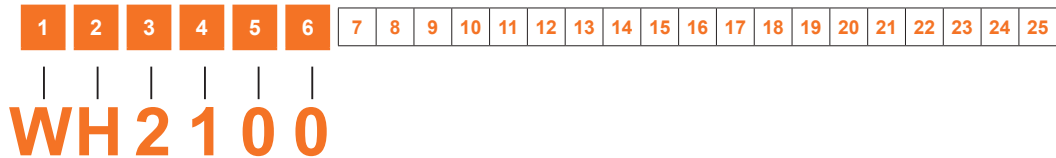



Digit	Feature	Value	Description
1	Specification	W	Water cooled chiller
2	Version	H	Standard Version - Screw Compressors
3	Number of circuit(s) / compressor(s)	2	2 circuits / Compressor
4 5 6	Cooling capacity (x 10 kW)	100	100 x 10 = 1000 kW
7	Display and switch	A B C	Small Graphic Display Small Graphic Display + Network Switch Seven Inches Touch Screen + Network Switch
8	Free option	0	None
9	Monitoring	0 1 2 3 4 5	None Modbus 485 + HTTP/WEB Modbus Over IP + HTTP/WEB BACnet MSTP + HTTP/WEB BACnet Over IP + HTTP/WEB SNMP + HTTP/WEB
10	Power factor correction	0 1	None Power Factor Connection
11	Free	0	None
12	Free	0	None
13	Special instrumentation	0 1 2 3	None Energy Meter Chilled Water Meter Energy Meter + Chilled Water Meter
14	Fast start ramp and control supply	0 1 2	None Fast Start Ramp - Easy: no need of UPS Line, on-board ultracap for control supply backup Fast Start Ramp - Classic: control under UPS Line
15	Low temperature device	0 1	Standard Electrical Panel Electrical Panel With Heaters
16	Low noise version	0 1	Standard With Panel and insulation
17	Free	0	None
18	Special requirements	0 X	Standard As specified

Note The WHT versions are managed as special options.

3. Intended Use

The **HPC-W** units have been designed and manufactured for production of chilled water. They are made of two refrigerating circuits, each one with a screw-compressor, a water-cooled condenser and a tube evaporator. The tube evaporators of both the circuits are coupled in the same heat-exchanger where the water is chilled. The **HPC-W** units are factory assembled and pre-charged. All the internal wiring is completed at the factory. Only electrical and water connections must be made at the installation site. See Chapter *Description* for details about the units structure, versions and optional components.

3.1 Functional Limits

Refrigerant	<p>This unit is designed for use with R134a/R513A (group 2, not dangerous according to PED Directive).</p>  <p>WARNING Risk of components failure or breakage. Do not use other refrigerants. Contact the manufacturer in case of doubt.</p>
Electrical system requirements	<p>Voltage: 400 V - 3 phase - 50 Hz</p>  <p>WARNING Risk of components failure or breakage. Do not use different voltage. Contact the manufacturer in case of doubt.</p>
Performance	See <i>Technical Data and Performances</i>

3.2 Operating Environment

This unit is designed for indoor installation, protected from weather agents, with the following ambient conditions:

Ambient temperature	<p>0°C – +40°C</p> <p>For installation with ambient temperature below 0°C see <i>Prevent freezing</i> and other necessary arrangement as per Vertiv specification.</p> <p>Thermal limits on electric board due to room conditions:</p> <ul style="list-style-type: none"> - Room temperature max. = 40°C - Room temperature min. without electric board heater = 0°C - Room temperature min. with electric board heater = -10°C <p>NOTE <i>The ambient temperature must not reach the 50°C, because in this condition the safety valve on the low pressure side will open.</i></p>
Ambient humidity	5% – 80% non-condensing
Ambient conditions	<p>Indoors and protected against weather agents</p> <p>Do not use in explosive, acid or anyway aggressive atmosphere.</p>
Storage Conditions	<p>Temperature +0°C – +45°C</p> <p>Humidity: 5 - 80% non-condensing</p> <p>Indoors and protected against weather agents</p>

3.3 Space Limits

Overall unit dimensions	Provide enough free space to place the unit. See <i>Annex I – Dimensions and Weights</i>
Clearance	Keep a free space around the unit as explained in <i>Space Requirements</i> .

4. Reference Norms

HPC-W units are designed, manufactured and tested according to the following directives and standards:

- EU Directives**
- Machine Directive 2006/42/CE
 - PED Directive 2014/68/EU
 - Low tension Directive 2014/35/UE
 - EMC Directive 2014/30/UE

CE Marking and Conformity Declaration

The units are marked “**CE**”.

Each unit is supplied complete with individual test certificate and a certificate of conformity to the European Union Directives.

See also the last page.



UKCA Marking and Conformity Declaration

The units are marked “**UKCA**”.

Each unit is supplied complete with individual test certificate and a certificate of conformity to the UK Safety Regulations



- Performance test norms**
- Cooling Capacity according to EN 14511
 - Sound Pressure level according to ISO 3744
 - SEPR according to Regulation EU 2016/2281

5. Description

5.1 Versions

The **Liebert® HPC-W** units are available in the following versions:

Feature	Standard version	Special version
Circuit	Dual circuit	---
Noise	Without additional sound insulation	With sound insulation material and enclosure around the compressors and the most relevant noise sources
Water conditions	WH version Evaporator: - Max Temperature outlet 12°C - Min temperature outlet 2°C Condenser: - Max condenser inlet temperature: 42°C	WHT version Evaporator: - Max Temperature outlet 25°C - Min temperature outlet 13°C Condenser: - Max condenser inlet temperature: 50°C

5.2 Structure

5.2.1 Standard version

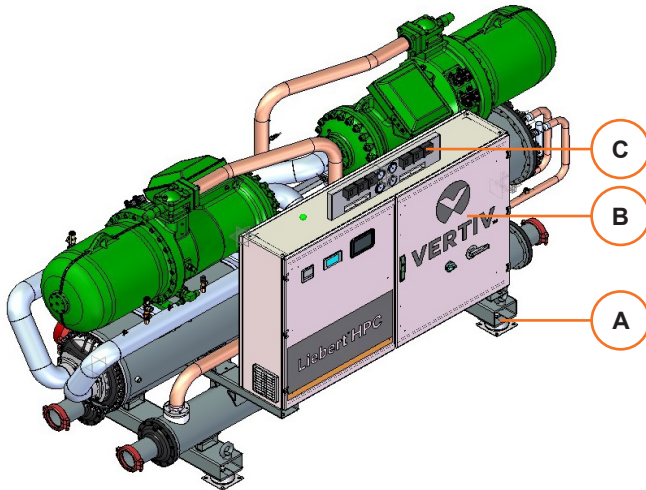

- A Supporting structure

- B Electric box

- C Instruments panel

5.2.2 Low noise version

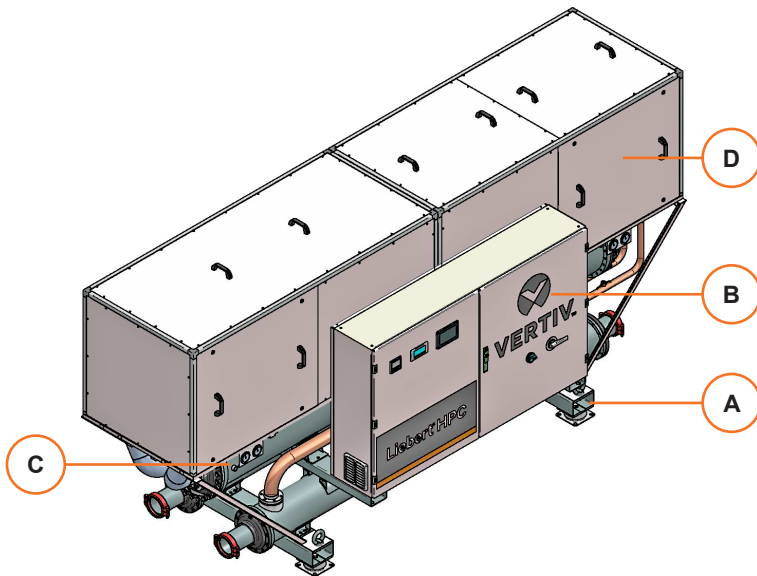

- A Supporting structure

- B Electric box

- C Instruments panel

- D Enclosure for noise reduction

5.3 Refrigerating System

5.3.1 Main components

Front view

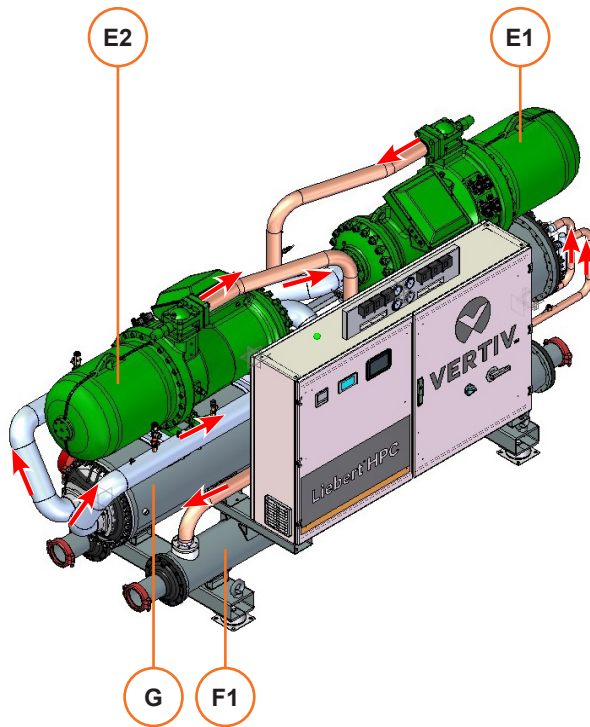

E1 / E2	Semi-hermetic screw compressor
F1 / F2	Condenser, water cooled
G	Shell tube evaporator

The unit is equipped with two independent refrigerating circuits, each one composed of a water-cooled condenser, a semi-hermetic screw compressor, a shell-tube evaporator and lines.

The tube evaporators of both the circuits are coupled in the same shell heat-exchanger. The water flows in the shell and is chilled.

The components of the liquid line are:

- Charging valves
- Filter-dryers
- Moisture indicator
- Electronic expansion valve
- For some units only, there is a by-pass EEV line made of:
 - shut-off valve
 - check valve
 - solenoid valve

Rear view

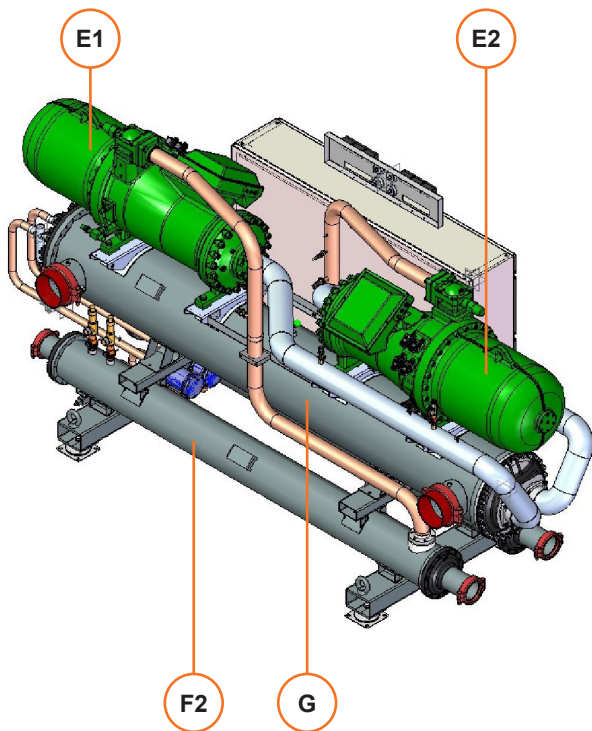

A shut-off valve is installed on the discharge of the compressor.

See *Annex II – Refrigerating Circuit* for details.

5.3.2 Safety devices

Each refrigerating circuit is provided with the following safety devices:

Safety valves

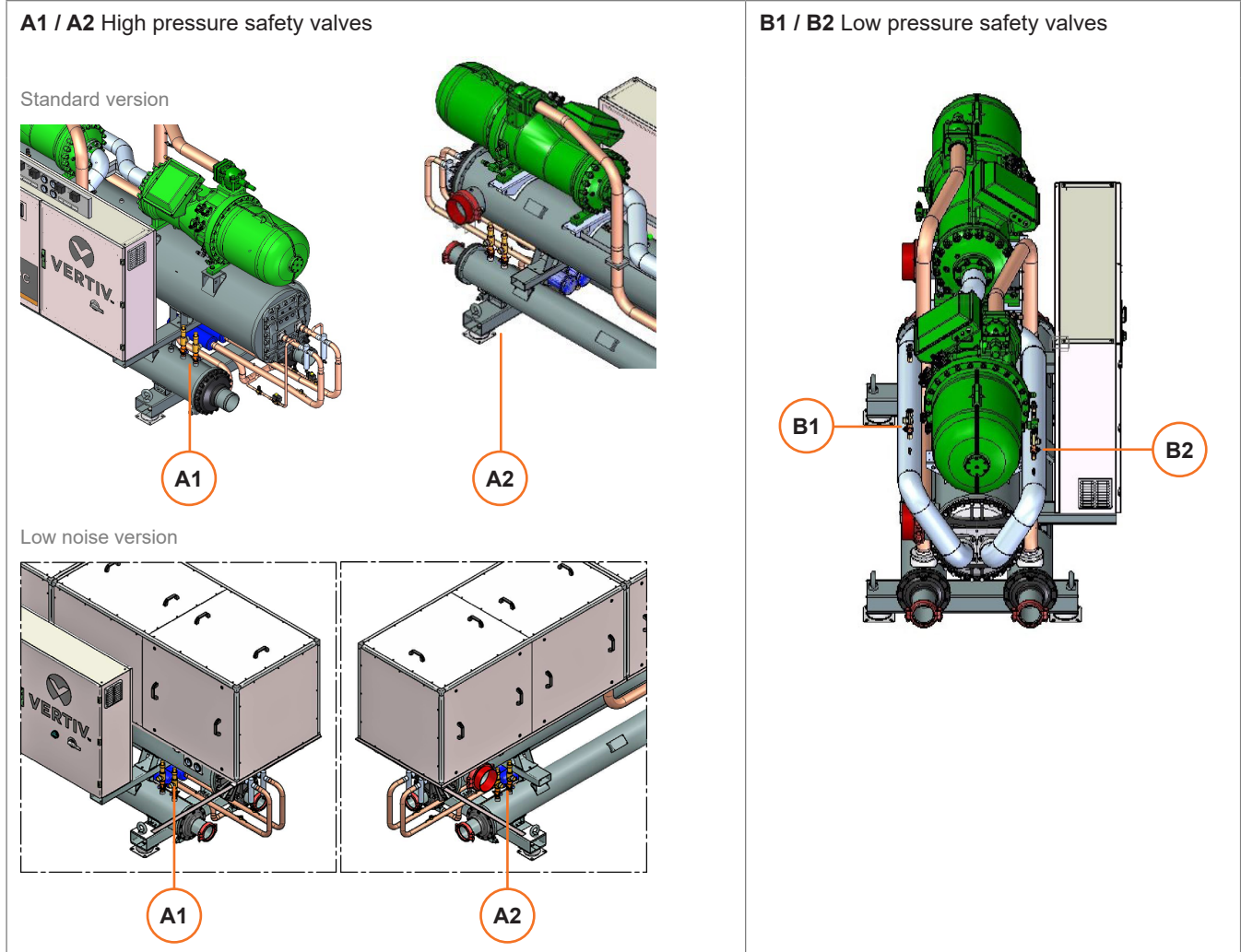

See *Operating Limits* for details.
See also *Calibrations* for maintenance and calibration operations

 **WARNING**
Make sure that the safety valves are always free to discharge.
Do not cover the safety valves.

 **NOTICE**
The running of pressure equipment and pressure assemblies is excluded by the scope of PED Directive, but it's regulated in compliance with national regulations of Member States of European Communities.
The shut-off valves, installed between vessel and safety valve, allow removing the valve for periodic checking or replacement without blowing off all the refrigerant from a section of the system.
The safety valves are installed in open position and the ball spindle is protected by means of a cap screwed to the body and sealed with lead to it.
Any closing intervention on the valve forcedly causes the tampering of the seal and then these interventions shall be performed exclusively by:

- Staff authorized to work on the system;
- Public servant of a Competent Body;

These persons will be responsible for the next valve reopening and the new cap sealing with their own lead.

High pressure switches

Standard version

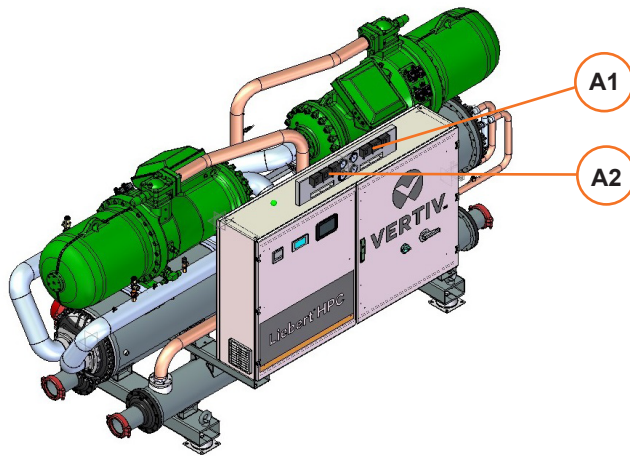

A1/A2 High pressure switches

See *Operating Limits* for details.
See also *Calibrations* for maintenance and calibration operations

Low noise version

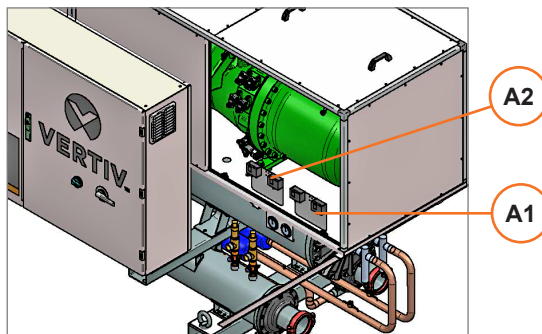

5.3.3 Sensors and instruments

Each refrigerating circuit is provided with the following sensors and instruments:

Standard version

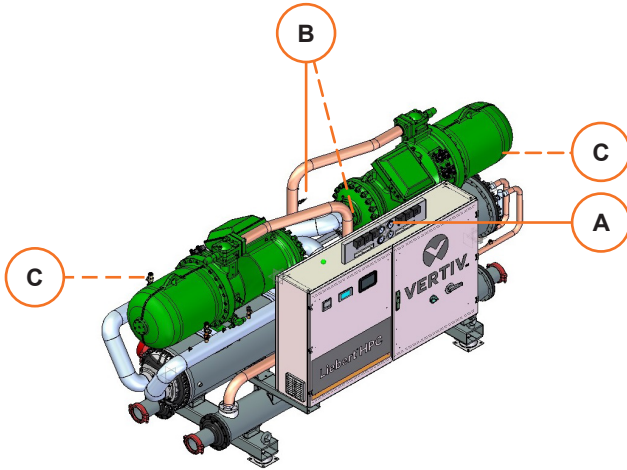

A	Manometers	High and low pressure
B	Pressure transducers	High pressure
C	Pressure transducers (placed inside the compressor suction piping, not visible in the picture)	Low pressure

Low noise version

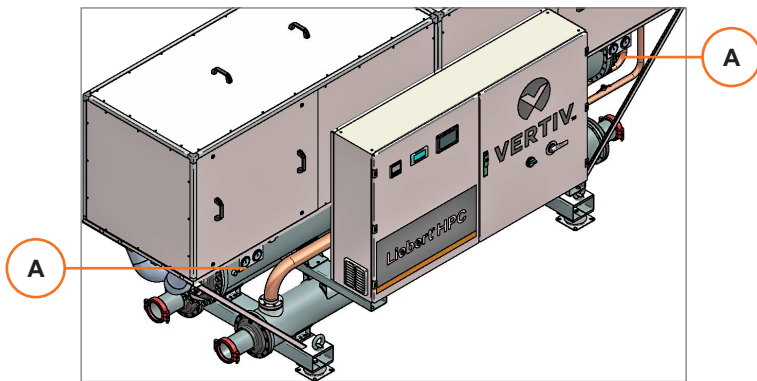

5.3.4 Compressors

Type	Semi-hermetic screw compressors Integrated shut-off valve on the discharge line
Safety	Internal safety valve according to EN 60335-2-34
Protection	Electronic protection controlling: <ul style="list-style-type: none"> - the temperature of the motor windings - the oil temperature - the screw rotating direction <p>The compressor motors are equipped with protection on all the three phases and are started by their three-pole contactors.</p>
Oil system	Oil heater Oil sight glass Oil level control Fine filter 10 µm mesh size

5.3.5 Electronic expansion valve

Features	<p>The electronic expansion valve used in the Liebert® HPC-W range enables accurate and minimum possible control of the overheating of the gas sucked by the compressor under all load conditions, together with the operation at low condensation and high compressor choking.</p> <p>The final result of the application of the electronic expansion valve on Liebert® HPC-W is therefore an improved energy operating costs and a higher reliability, thanks to its special adjustment features above all on partial loads, conditions under which every chiller operates for most of the time.</p>
Operation	<p>The superheat setpoint will be automatically adjusted according to the operating conditions and to the application limit of the compressor.</p> <p>The operating parameters and their programming in the microprocessor dedicated to the EEV control are described in the <i>VERTIV™ iCOM™ User Manual</i>.</p>

5.4 Water System



NOTE

This chapter describes only the components that are part of the **Liebert® HPC-W** units. The complete water system must be prepared by the customer according to the specifications given in *Water System Specifications*.

5.4.1 Main components

The hydraulic circuit is made up of grooved hydraulic lines ready to be connected to the plant by joints (grooved type).

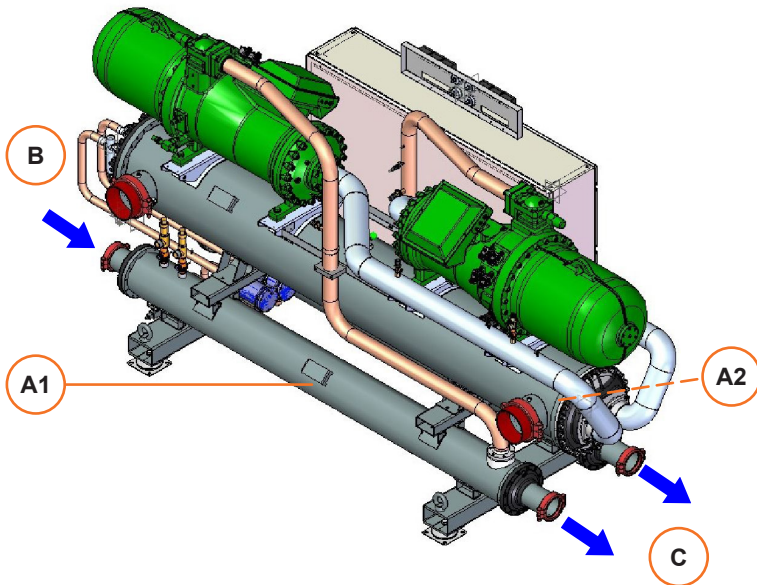

A1 / A2	Condensers
B	Condenser water inlet
C	Condenser water outlet

Each condenser is water cooled.

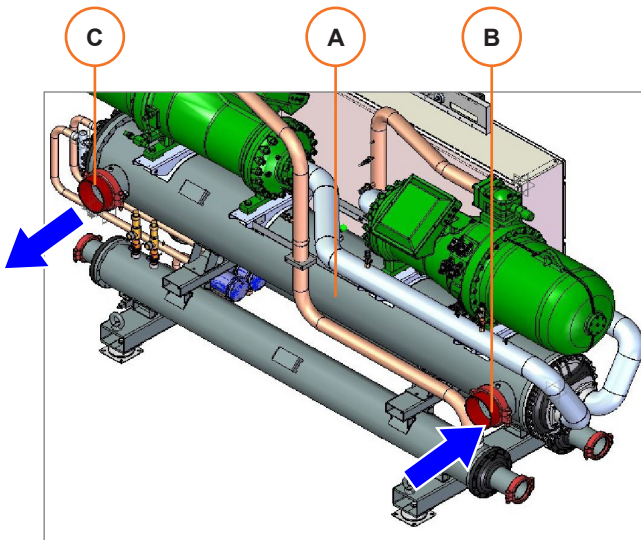

A	Evaporators - chilled water heat-exchanger
B	Evaporator water inlet
C	Evaporator water outlet

The chilled water flows through the evaporator.

5.4.2 Sensors and instruments

Each water circuit is provided with the following sensors and instruments:

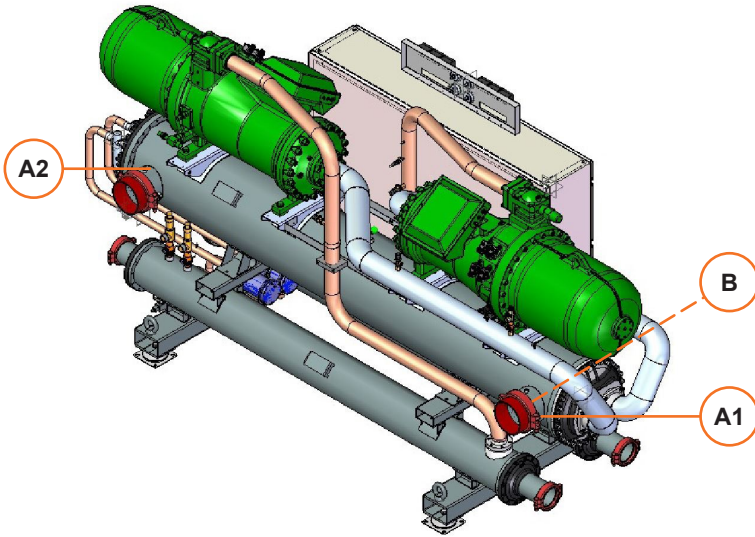

A1 / A2	Temperature sensors (NTC)
B	Flow switch at evaporator inlet
---	Water meter on the evaporator (optional)

5.5 Electric System

5.5.1 Electric box and main switch

Electric box

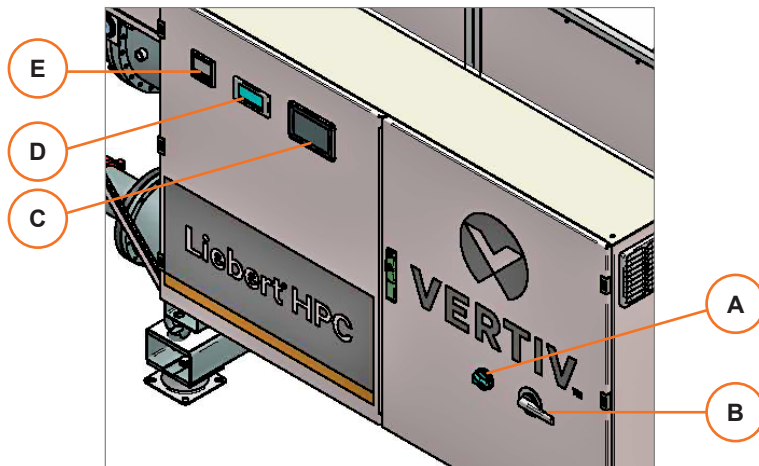

- A** Main switch secondary power supply (control and auxiliary systems)

- B** Main switch
This is a disconnecting switch and cuts off the electric power supply to the whole unit.

- C** Touch screen panel (optional)
See the *VERTIV™ iCOM™ User Manual* for details.

- D** VERTIV™ iCOM™ control panel
See the *VERTIV™ iCOM™ User Manual* for details.

- E** Display of the flow-meter (optional)

The electrical panel is designed and manufactured according to CEI EN 60204-1

5.5.2 Electrical connections

Electrical service entrances

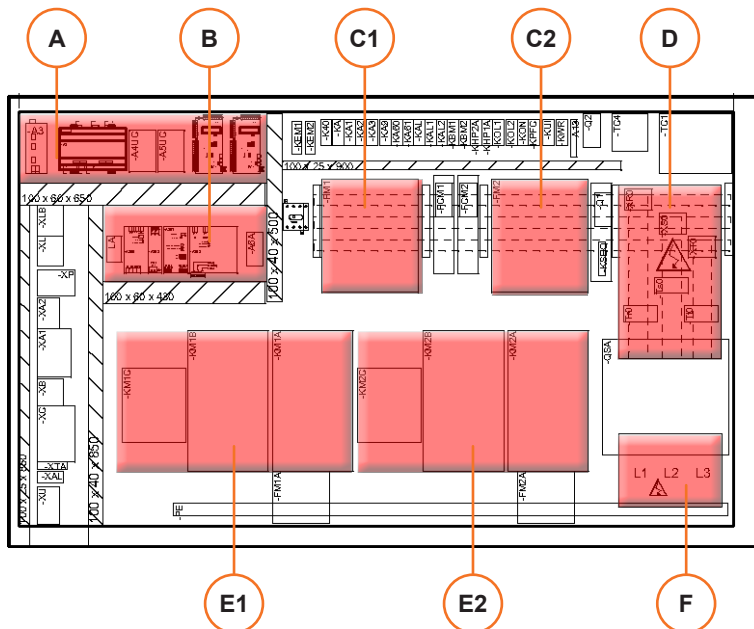

- A** Control board

- B** Ultra-capacitor

- C1 / C2** Fuse holder for compressors

- D** TAN for energy meter (optional)

- E1 / E2** Compressor contactors

- F** Three-phase electrical connection

5.6 Control System

5.6.1 VERTIV™ iCOM™

The **Liebert® HPC-W** water chillers are controlled by the Vertiv™ iCOM™ microprocessor, managing all of the unit operating conditions.

The user can change and/or modify the operating parameters through the display keyboard installed on the electrical panel. The electrical control board with fan is equipped with all the safety and operating devices needed for reliable automatic operation. See the *VERTIV™ iCOM™ User Manual* for details.



NOTICE

The **Liebert® HPC-W** are equipped with their own microprocessor control for the water temperature adjustment. There is no connection for a remote ON-OFF control. Any modification is forbidden.

5.6.2 Protective Functions

The **Liebert® HPC-W** water chillers are automatically protected through a series of warning and alarm to prevent damages to the chiller itself:

Pressure control	High pressure and low pressure alarm
Out of Envelope alarm	Modulation of capacity based on the value of high pressure, low pressure, superheat and subcooling and the operating map of the compressor installed
Oil level	Low level alarm
Refrigerant charge check function	Monitoring of the subcooling value with warning or alarm depending on the working conditions
Compressors	<p>The compressors are equipped with an electronic protection device blocking their start if the phase sequence is not correct, or stopping their operation if a thermal relay intervenes.</p> <p>This device is essential for the integrity of the mechanical and electrical components of the compressors.</p> <p>In case of stop due to this device intervention:</p> <ol style="list-style-type: none"> 1. isolate this device 2. remove the causes of the lock-out 3. reset the device by the VERTIV™ iCOM™

5.6.3 Fast Start Ramp and Control Supply

The Vertiv™ iCOM™ for **HPC-W** control is fed by direct current for immunizing from network disturbances. There are 3 possible power supply choices to guarantee reliability and fast start:

Option 0 (None) The unit is powered by a single three-phase line.
The control is powered by an AC/DC converter three phases, that insulate the control from the external electric noises.

Option 1 (Fast Start Ramp – Easy) The unit is powered by a single three-phase line.
A capacitors module (Ultracapacitor) is installed for the direct microprocessor power supplying.
In case of main supply Power **OFF**, the control is powered for **90** seconds (minimum buffer time guaranteed, the amount of time is function of unit configuration).
- If the main supply power restores within the buffer time, the control re-start quickly the controlled components.
- If the main supply power restores out of the buffer time, the control start the reboot procedure and the ultracapacitor requires **15** minutes to recharge completely.
More repetition of power **OFF** in a short time and/or long power **OFF** time reduces the minimum buffer time.
The ultracapacitor has a potentially unlimited lifetime, not required maintenance.



NOTICE

The ultracapacitor working temperature limits are -40°C ÷ +60°C

Option 02 (Fast Start Ramp – Classic) The unit is powered by two power lines:
- A three phases line for the high power components;
- A single phase for the control, typically provided by a UPS installed by the customer/user.
The control is powered by a AC/DC single-phase converter, connected to the single-phase power line, that insulates the control from the external electric noises.
In case of three-phase line power **OFF**, the control remains power supplied by its dedicated power supply line, ready to start quickly when the three phases power **ON**.

5.7 Special Instrumentation

5.7.1 Energy Meter (Optional)

For a full description please look at manual available on the unit.

Parameters device are set on factory; it can show:

- currents
- powers
- energy values

5.7.2 Water Meter

Safety informations



WARNING

Pressurized System

Depressurize and vent system prior to installation or removal.



DO NOT exceed maximum temperature or pressure specs.

ALWAYS wear safety goggles or faceshield during installation and/or service.

DO NOT alter product construction.



WARNING

Paddlewheel retaining nuts

The retaining nuts of paddlewheel sensors are not designed for prolonged contact with aggressive substances.

Strong acids, caustic substances and solvents or their vapor may lead to failure of the retaining nut, ejection of the sensor and loss of the process fluid with possibly serious consequences, such as damage to equipment and serious personal injury.

Retaining nuts that may have been in contact with such substances, e.g. due to leakage or spilling, must be replaced.

Max. pressure : 12.5 bar at 200C.



NOTICE

Hand tighten only. Do not use tools

Overtightening may permanently damage product threads and lead to failure of the retaining nut.

Use of tool(s) may damage product beyond repair and potentially void product warranty.

Characteristics

Flow rate range 0.1 to 6 m/s (0.3 to 20 ft/s)

Installs into pipe sizes DN15 to DN900 (½ to 36 in.)

High resolution and noise immunity

Chemically resistant materials

Easy to replace rotor

Installation

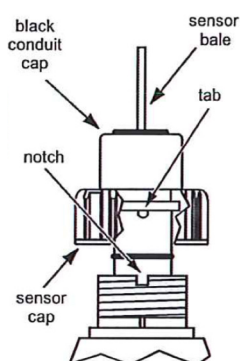

Lubricate O-rings with a non-petroleum based, viscous lubricant (grease) compatible with the system.

Using an alternating/twisting motion, lower the sensor into the fitting, making sure the installation arrows on the black cap are pointing in the direction of flow, as shown in the following figure:

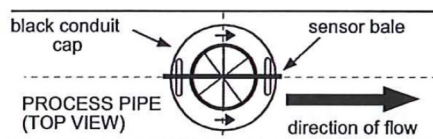

Engage one thread of the sensor cap then turn the sensor until the alignment tab is seated in the fitting notch.

Hand tighten the sensor cap. Do not use any tools on the sensor cap otherwise the cap threads and/or the fitting flange threads will be damaged

5.8 Accessories

The customer is responsible for the installation of the accessories, which are provided separately.

5.8.1 Anti-vibration support

Rubber support dimensions

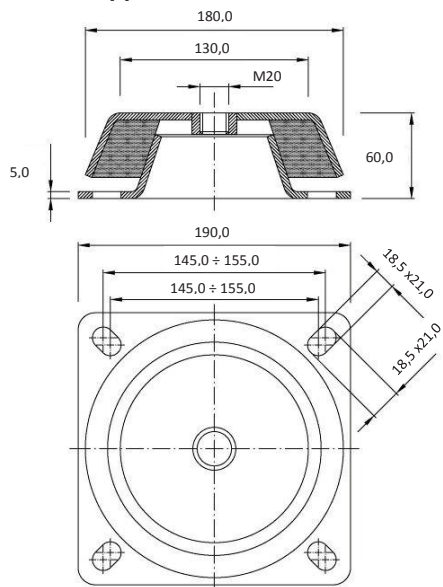

Rubber support installation

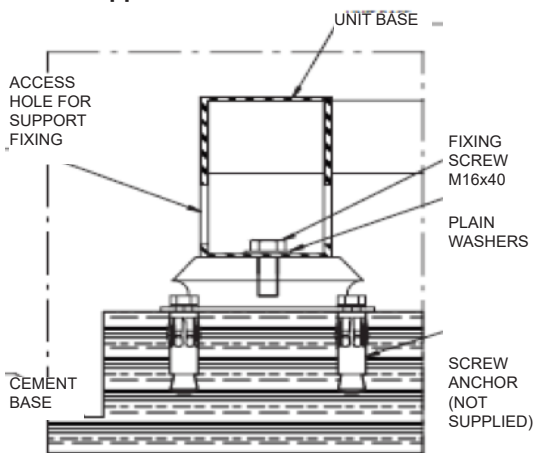

HPC-W model	Support kit code	Singles support code	Number of pieces
WHT2131 WH2131/ 051584 Order n° 65601914	10035366	60056558	4

Each kit is complete with stainless steel fixing screws and plain washers for unit assembly.

5.8.2 Other accessories

Component	Code for all the HPC-W models
Paddle flow switch	354404
Y - filters available upon request for evaporator and condenser	

6. Technical Data and Performances

6.1 Refrigerating System

Table 1 – Refrigerating System – WHT models

Model	WHT2131: WH2131/051584 Order n° 65601914
Number of refrigerant circuits	2
Refrigerant charge R513A (each circuit) [kg]	152
Oil charge (each circuit) [kg]	30
Number of evaporators	1
Number of condensers	2

6.2 Water System

Note 1	Higher flow rate may cause corrosion and vibrations of shells and tubes.
Note 2	If the water flow rate is too low, then safety devices lock the unit because the heat exchange is too low. Make sure that the water flow rate is compatible with the values given in <i>Table 3</i> and <i>Table 4</i> .
Note 3	The modulation with capacity 25-100% in the single-circuit units is allowed only with the electronic expansion valve.
Note 4	These limits apply to new machines, subject to correct installation and maintenance.
Note 5	The maximum allowed water return temperature, when the unit is in full operation, is: <ul style="list-style-type: none"> - 18°C for WH models - 32°C for WHT models Higher return temperatures are allowed only during start-up.

Table 2 – Water System – WHT models

Model	WHT2131: WH2131/051584. Order n° 65601914
Evaporator	
Water Volume [dm ³]	901
Condenser	
Water Volume each hydraulic circuit [dm ³]	166
Working range	
Max evaporator inlet water temp. [°C]	32
Min evaporator inlet water temp. [°C]	23
Max evaporator outlet water temp. [°C]	25
Min evaporator outlet water temp. [°C]	13
Max evaporator flow [m ³ /h]	250
Min evaporator flow [m ³ /h]	91
Max condenser flow [m ³ /h]	2x230
Min condenser flow [m ³ /h]	2x110
Hydraulic Connection	
Condenser connection Grooved Coupling	DN150 6" 168,3 mm
Evaporator connection Grooved Coupling	DN250 10" 273,1 mm
Maximum Operating Pressure	
Evaporator Side [barg]	10,5
Condenser Side [barg]	16,0

6.3 Operating Limits

Table 3 – Operating Limits

Model	WHT2131: WH2131/051584 Order n° 65601914
Working range	
Max condenser inlet water temp. [°C]	50
Min evaporator outlet water temp. [°C]	13
Max evaporator flow [m ³ /h]	250
Max condenser flow [m ³ /h]	2x230
Safety devices settings	
High pressure switch (HP) [barg]	20
High pressure safety valve [barg]	22
High pressure safety valve each circuit	2 (+2)
High pressure safety valve connection	1 1/4" G-M
Low pressure safety valve [barg]	14
Low pressure safety valve each circuit	1
Low pressure safety valve connection 1"	1" G-M

6.4 Electrical System

Table 4 – Electrical System Data

Model	Operating Ampere ⁽¹⁾ [A]	Full Load Ampere [A]	Locked Rotor Ampere [A]	Maximum Absorbed Power [kW]	Minimum Circuit Braker [A]	Cable Size [mm ²]
WHT2131 WH2131/ 051584. Order n° 65601914	648	900	1255	560	1000	3x185

Note 1 Reference condition for operating ampere:

Power supply	Refrigerant	Evaporator: inlet/outlet water temperature	Condenser: inlet/outlet water temperature
400 V / 3 ph / 50 Hz	R513A	31,7°C/ 21,7°C	49,6°C/ 54,6°C

6.5 Noise Level

The tables show the noise data for the units in standard and low noise versions, operating continuously at full load at the following conditions:

	Water at Evaporator		Water at Condenser	
	Inlet	Outlet	Inlet	Outlet
WHT models	26°C	20°C	35°C	40°C

Note 1 The value of **PWL** (Sound Power Level) is calculated in according to ISO 3744 procedure method.
Sound Power Level tolerance for each octave band: -0 / +2 dB

Note 2 The value of **SPL** (Sound Pressure Level) for every octave band frequency is measured in free field conditions and at 1 meter from the unit according to ISO 3744 average method.
Sound Pressure Level tolerance for each octave band: -0 / +2 dB

Note 3 Avoid positioning in rooms with high reverberation of the sound waves, which can adversely effect the noise levels.

6.5.1 Standard Version

WHT models

Table 5 – Sound Power Level [dB]

Model	Octave Band Frequency								Total PWL [dB(A)]
	63 Hz	125 Hz	250 Hz	500 Hz	1000 Hz	2000 Hz	4000 Hz	8000 Hz	
WHT2131	90,5	97,0	90,8	102,1	97,1	85,0	73,7	65,8	101,4

Table 6 – Sound Pressure Level at 1 m in free field [dB]

Model	Octave Band Frequency								Total SPL [dB(A)]
	63 Hz	125 Hz	250 Hz	500 Hz	1000 Hz	2000 Hz	4000 Hz	8000 Hz	
WHT2131	71,1	77,6	71,3	82,7	77,6	65,6	54,2	46,4	81,9

6.5.2 Low Noise Version

WHT models

Table 7 – Sound Power Level [dB]

Model	Octave Band Frequency								Total PWL [dB(A)]
	63 Hz	125 Hz	250 Hz	500 Hz	1000 Hz	2000 Hz	4000 Hz	8000 Hz	
WHT2131	92,3	88,8	82,3	88,4	92,4	75,3	65,1	57,4	93,4

Table 8 – Sound Pressure Level at 1 m in free field [dB]

Model	Octave Band Frequency								Total SPL [dB(A)]
	63 Hz	125 Hz	250 Hz	500 Hz	1000 Hz	2000 Hz	4000 Hz	8000 Hz	
WHT2131	72,8	69,4	62,9	69,0	73,0	55,9	45,6	37,9	73,9

7. Handling

7.1 Safety Instructions



WARNING

Improper handling can cause injury or death.

Only authorized personnel is allowed to move, lift, remove packaging from or prepare the unit for installation.

The authorized personnel must be properly trained and qualified, wear appropriate personal protective equipment and use adequate moving equipment (cranes, forklift, etc.).



WARNING

Make sure to use transport and lifting equipment rated for the unit dimensions and weight.

See *Annex I – Dimensions and Weights*



WARNING

Never walk or stay below a suspended load.



CAUTION

Sharp edges, splinters and exposed fasteners.

Wear protective gloves before operating on the unit.



NOTICE

Improper handling can cause product damage.

7.2 Inspection

- After receiving the product, check the accessories against the packing list.
- If any parts are found missing or damaged, please report to the carrier immediately.
- If you find any damage, please report to the carrier and to the local distributor too.

7.3 Storage

You may keep the unit in a storehouse with the following ambient conditions:

Item	Requirement
Storage environment	Indoor environment, protected against weather agents Clean (no dust), well-ventilated, non-condensing,
Ambient temperature	+0°C – +45°C NOTE <i>The ambient temperature must not reach the 50°C, because in this condition the safety valve on the low pressure side will open.</i>
Ambient humidity	5 - 80%
Storage time	The total storage time should not exceed six months. If the storage time is longer than six months, then you must check the functionality of sensors and other electronic devices before putting in operation the unit.

7.4 Transport (with or without Package)

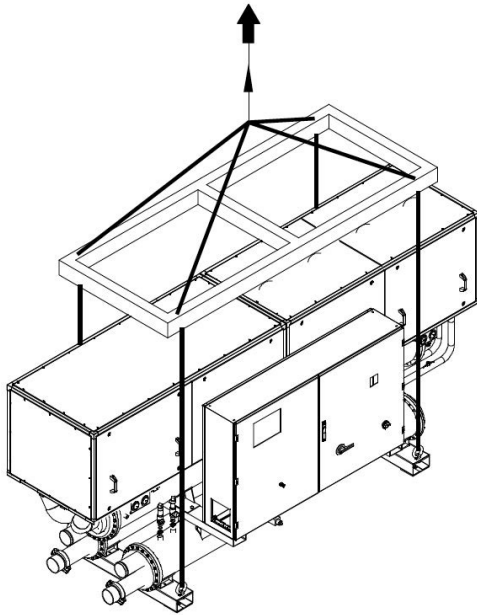

1. Insert a sling in each of the iron beams [A].
2. Use a crane to move the unit.



NOTICE

Do not use a forklift to move the unit. The structure does not support heavy loads and would be damaged.



NOTICE

Lift the unit with a speed suitable for the load to be moved, so as not to damage the structure.

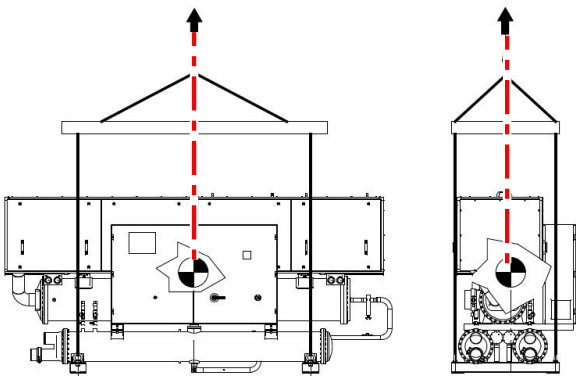

WARNING

The lifting point must be aligned with the gravity center

- Make reference to *Annex I – Dimensions and Weights* for dimensions, weight and gravity center position.
- If the unit is still packaged, pay attention to the gravity center and warning labels placed on the unit.

7.5 Unpacking



When packaged, the unit is fixed on a pallet by four bolts. The bolts are under the eyebolts [A].

- Remove the exterior packaging material from around the unit.
- Dispose of the package materials according to the local regulation about waste disposal.
- Remove the bolts securing the unit to the pallet.



NOTICE

Pay attention not to damage the protruding parts.

8. Installation



NOTICE

The installation of the unit must comply with EN378-3.

8.1 Overview

8.1.1 Preparation of the installation site (by the customer)



NOTICE

Vertiv™ takes no responsibility for systems not compliant with the specifications given in this manual. Lack of compliance to the specifications given by Vertiv™ voids the warranty.

The customer is responsible for the following operations.

Operation	See ...
Prepare the area	8.3 Installation Site
Prepare the water system	8.4 Water System Specifications
Prepare the electric system	8.5 Electric System Specifications

8.1.2 Operations on the unit

The unit is delivered fully assembled at the factory, including all the internal wiring.

Before shipment each unit is charged with the right amount of refrigerant and oil. Each unit is then tested under the operating conditions required by the customer.

The heat exchangers (evaporator and condensers) are supplied dry, with open drain plugs and exhaust valves, to avoid possible problems due to the frost in the storage period.

The following operations must be done on the **Liebert® HPC-W** unit at the installation site:

Operation	See ...
1. Position the unit at the final location and fix it on the floor or the supporting structure	8.6 Positioning
2. Connect the water system to the unit	8.7 Connections - 8.7.1 Water system piping
3. Connect the electric power supply	8.7 Connections - 8.7.2 Electrical power supply
4. Connect the electric equipment to the electric box (optional connections)	8.7 Connections - 8.7.3 Ethernet cable connection - 8.7.4 Contacts for the unit status signals - 8.7.5 Pumps electrical connection - 8.7.6 Instrumentation connection
5. Connect the discharge of the safety valves	8.7 Connections - 8.7.7 Safety valves discharge
6. Fill the water system	8.8 Filling the Water System
7. Check the system	8.9 Initial Checks
8. Start the unit for the first time	Operation
9. Check or set up the operating parameters of the control system	VERTIV™ iCOM™ User Manual

8.2 Safety Instructions

Personnel		<p>WARNING</p> <p>Only authorized personnel is allowed to do installation operations.</p> <p>All work on pipes or components of the refrigerating circuit under pressure must be exclusively made by qualified staff, competent in such works.</p> <p>The authorized personnel must be properly trained and qualified, wear appropriate personal protective equipment and use adequate tools.</p>
Electric System		<p>WARNING</p> <p>Unit contains potentially lethal voltage in some circuits.</p> <p>Risk of arc flash and electric shock. Can cause injury or death.</p> <ul style="list-style-type: none"> • Open all local and remote unit electric power disconnect switches, verify with a voltmeter that power is OFF and wear protective equipment per local standard before working within the electric control enclosure. • It is forbidden to operate on the electrical components without using insulating platforms, or in the presence of water and humidity.
		<p>WARNING</p> <p>The electric connection enclosures and some components can retain a stored high-voltage electrical charge for up to 10 minutes.</p> <p>Risk of electric shock. Can cause serious injury or death.</p> <p>Before working within the unit electric connection enclosures proceed as follows:</p> <ul style="list-style-type: none"> • open all local and remote unit electric power disconnect switches • wait 10 minutes • verify with a voltmeter that power is OFF <p>Only properly trained and qualified personnel may perform repair, maintenance and cleaning.</p>
Lockout-Tagout (LOTO)		<p>WARNING</p> <p>Before any intervention on the electrical system or accessing the inner components:</p> <ul style="list-style-type: none"> • Lock the disconnection device by a padlock or similar tool. • Apply on the general knife switch a suitable warning plate for no operation.
Safeguards		<p>CAUTION</p> <p>After the installation interventions, always close the unit by refitting the relevant panels, if present, fastened by the fixing screws.</p>
PPE		<p>CAUTION</p> <p>Sharp edges, splinters and exposed fasteners.</p> <p>Wear protective gloves before operating on the unit.</p>
		<p>NOTICE</p> <p>Improper handling can cause product damage.</p>

8.3 Installation Site

8.3.1 Location

- The **HPC-W** units must be installed indoors, in rooms protected from weather agents.
- Prepare a level surface suitable to support the weight of the **Liebert® HPC-W** unit.
- The unit produces heat. The installation site must have a good air flow, so to guarantee heat dispersion even in the most demanding operating conditions.
- Install the unit in an area with clean air, away from loose dirt and foreign matter.

8.3.2 Space Requirements

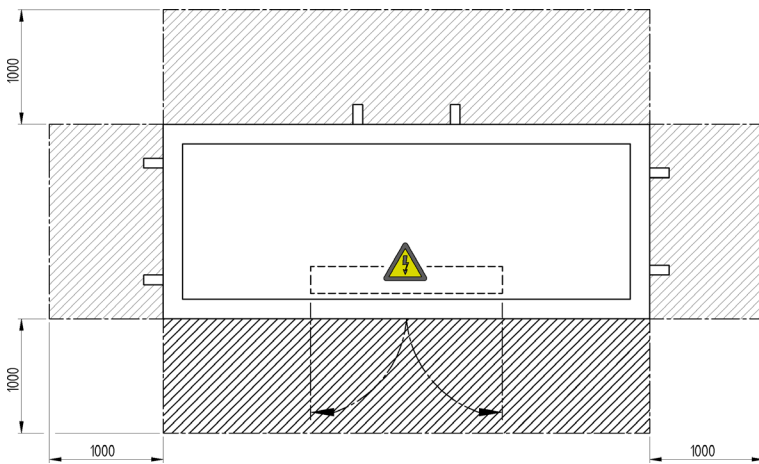

- See *Annex I – Dimensions and Weights* for the unit dimensions
- Keep a free space between the unit and any obstacle as shown in the figure.



NOTICE

The maintenance of the unit become extremely difficult if placed too close to walls or other obstacles

8.4 Water System Specifications

8.4.1 Ideal water circuit

The evaporator and the condensers of the **HPC-W** must be connected to the chilled water circuit. The customer is responsible for the water circuit, according to the following example and specifications. The following figure shows an ideal circuit for the evaporator (chilled water). Unless otherwise specified, the same components must be installed also on the condenser circuits.

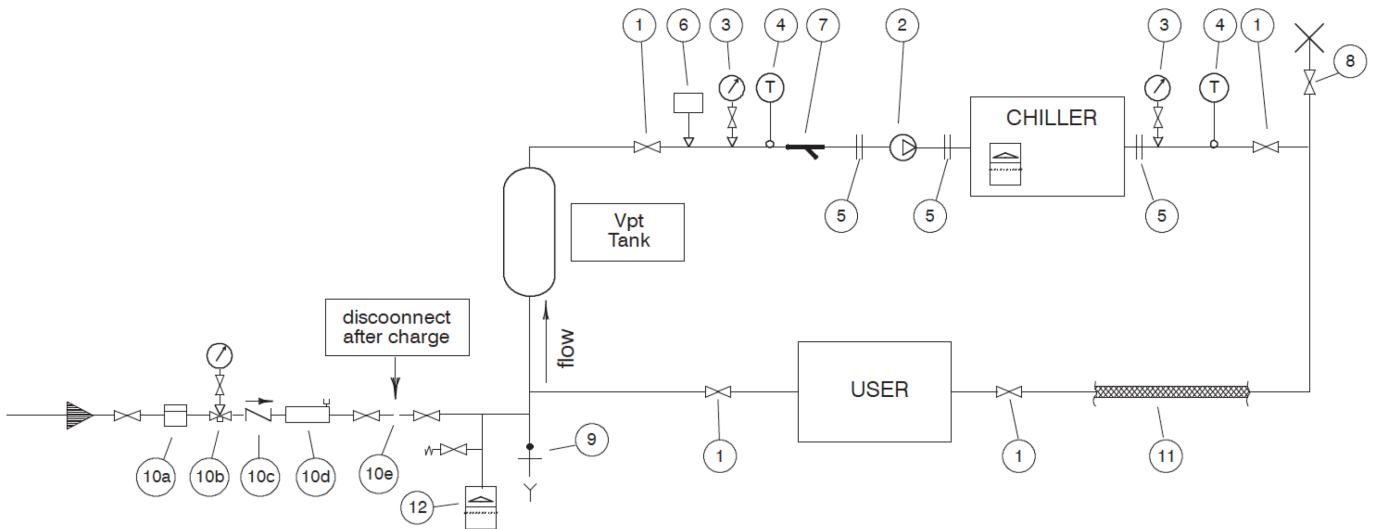

Ref.	Description	Notes
1	Shut-off valves	Install shut-off valves to facilitate maintenance. Do not install on the water outlet motorized shut-off valves configured as normally closed in stand-by status, because of the presence of check valves inside chiller on pump delivery. On the contrary, it is possible to install these motorized valves on the water inlets.
2	Pump	Install a circulation pump with the flow required by the plant and the head of all pressure drops of the plant. The board on the unit is able to manage the speed of the pump.
3	Manometers	Install manometer to the inlet and outlet of the Liebert® HPC-W
4	Temperature probes	Install temperature probes at the inlet and outlet of the Liebert® HPC-W .
5	Joints	Piping has to be connected to the Liebert® HPC-W with flexible connection in order to avoid vibration transmission.
6	Pressure switch	Install a pressure switch on water pipe to give an early warning of low water pressure.
7	Filter	Install mechanical filter at the inlet of the pump and at the inlet of the Liebert® HPC-W
8	Filling and venting devices	Install a device for the filling of glycol, placed at the highest points in the circuit. Install a device for the bleeding of air, placed at the highest points in the circuit.
9	Drain valve	Install a drain valve, placed at the lowest points in the circuit.
10	Water fill	Install a water fill group including the following components: a) filling meter b) manometer c) non return valve d) air separator e) removable supply tube, which must be disconnected after each charge or topping up
11	Insulation	All pipes of the system exposed to low temperature have to be isolated. Also consider to use heaters, if necessary.
12	Expansion tank	The circuit must include an expansion tank with suitable capacity. See 8.4.2 <i>Sizing of the expansion tank</i> for the capacity calculation. Install a safety valve on the expansion tank.

8.4.2 Sizing of the expansion tank

$$V = \frac{C \times e}{1 - \frac{P_i}{P_f}}$$

where:

C = quantity of water inside the system expressed in liters

e = water expansion coefficient, with water at 10°C as a reference

P_i = absolute pressure of initial charging, equivalent to the tank pre-charge pressure (typical value 2.5 bara)

P_f = absolute final tolerated pressure, lower than the operating pressure or than the safety valve calibration pressure (typical value 4.0 bara).

The total volume of the expansion tank is calculated with the ratio shown on the left.

Use the values of the water expansion coefficient indicated in the table below:

T [C°]	Density [Kg/m ³]	Expansion coefficient "e" H2O	"e" 10% glycol	"e" 20% glycol	"e" 30% glycol	"e" 40% glycol	"e" 50% glycol
10	999,6	0,001	0,003	0,005	0,007	0,013	0,015
20	997,9	0,002	0,005	0,008	0,01	0,015	0,018
30	995,6	0,004	0,007	0,011	0,013	0,017	0,02
40	992,2	0,008	0,011	0,014	0,016	0,021	0,024
50	988,1	0,012	0,015	0,018	0,021	0,025	0,028

8.4.3 Sizing of the chilled water circuit



NOTICE

The hydraulic circuit must ensure a constant water delivery to the evaporator in every operating condition. Otherwise, the compressors can break due to repeated returns of liquid refrigerant on their suction.

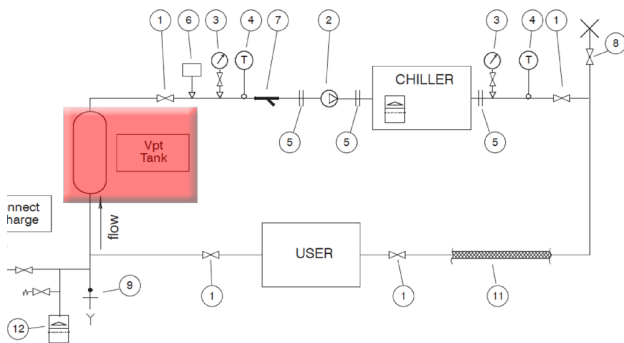

The whole evaporator circuit must contain a water volume suitable for the capacity of the installed refrigerating unit.

The minimum total volume (**V**) of the system where the **Liebert® HPC-W** is installed can be calculated by the following ratio:

$$V = \frac{43 \times R_t}{X_d}$$

where:

V = minimum required total water volume [liters]

R_t = refrigerating capacity [kW]

X_d = differential band set on the control [°C]

Check if:

$$V_m + V_{pc} \geq V$$

where:

V_m = hydraulic volume of the **Liebert® HPC-W** unit (see 6.1 Refrigerating System)

V_{pc} = volume of the water circuit connected to the **Liebert® HPC-W**

If **V_m + V_{pc} < V** then install an inertial tank with a volume (**V_p**) at least equal to the following value:

$$V_p = V - V_m - V_{pc}$$

8.4.4 System protection

Flow-switch

Normal operation:

1. The water pumps (evaporator and condenser) start.
2. There is water flow in the system.
3. The compressors start.
4. The compressors operate only if there is enough water flow in the system.

In case of pumps failure:

- The compressors must not start if there is no water flow in the system.
- The **Liebert® HPC-W** has factory mounted protections in case of lack of water flow in the condenser system (pressure-switch and software).
- The **Liebert® HPC-W** has no protection in case of lack of water flow in the evaporator system.

In order to prevent damage due to low or missing water flow in the evaporator:

- **The customer must install a flow-switch on the water supply to the evaporator.**
- **The flow-switch must be connected to the Liebert® HPC-W controller.**
- The controller starts and runs the compressors only if the flow-switch gives an **OK** signal.
- If the flow-switch detects lack of water flow in the evaporator the unit locks-out.



NOTICE

The installation of the flow-switch on the evaporator water supply is mandatory to maintain the warranty.

Three-way or two-way valve

The **Liebert® HPC-W** unit locks-out due to self-protection if the water to the condenser is out of the operating limits of temperature.

To prevent that, the customer may install a protection device on the condenser water system, as a three-way or two-way valve allowing the water recirculation on the condenser.

Max. hydraulic operating pressure

The maximum hydraulic operating pressure of the **Liebert® HPC-W** is 10 barg.

- Check how much is the maximum pump static head (**Pp**) (indicated on pump's name plate).
- Check the static head of the water circuit (**Pw**).
- Make sure that it is always: **Pp + Pw < 10 barg**.

Optional: install on the water circuit a safety valve set at 6 barg.

8.4.5 Water supply specifications

Analyze the water

It is the user's responsibility to establish the quality of the water and make sure that this is compatible with the materials used in the exchangers.

The quality of water may significantly affect the operation and the life of the exchangers.

The first step in the planning the treatment of the water is chemical analysis, which must be performed by qualified personnel from specialist organizations.

Water quality has to be in accordance with VDI 2035.

Add water softeners

In tower water, the tendency to form deposits may be high: to reduce this phenomenon, there are various types of water softening treatments available, including the use of ion exchange resins.

Prevent corrosion

The oxygen dissolved in water increases the rate of corrosion.

The main factors causing corrosion are sulphur and carbon dioxide acids (see the Langelier and Ryznar indices).

A combined effect of fouling due to dust and organic material provides a support for bacteria, fungi and algae; the growth of organisms may produce an oxygen gradient and this results in rather severe pitting of the metallic surface.

The phenomenon of corrosion is obviously related to the material used on the liquid side of the heat exchanger.

The table on the right shows the reference values for corrosion on copper, these values must be considered as guidelines to avoid corrosion.

pH	---	7,5 ÷ 9,0
Alkalinity (HCO ₃ ⁻)	ppm	70 ÷ 200
SO ₄ ²⁻	ppm	< 100
HCO ₃ ⁻ / SO ₄ ²⁻	---	> 1,5
(Ca+Mg)/(HCO ₃ ⁻)	---	> 0,5
Cl ⁻	ppm	< 100
PO ₄ ³⁻	ppm	< 2,0
NH ₃	ppm	< 0,5
Nitrate(NO ₃ ⁻)	ppm	< 100
Free Chlorine (Cl ₂)	ppm	< 1
Iron Fe ³⁺	ppm	< 1
Copper Cu	ppm	< 1
CO ₂	ppm	< 10
H ₂ S	ppb	< 50
Oxygen content	ppm	< 0,1
Total Suspended solids	mg/l	< 1500
Electrical conductivity	µS/cm	10 ÷ 500
Total hardness	dH	4,0 ÷ 8,5

8.4.6 Prevent freezing

Prevent freezing by glycol

In winter, if the system is stopped, the water inside the exchangers can freeze damaging the system irreparably.

Thus, it is recommended to use glycol mixtures: please consider the different outputs and absorption by the chiller, the pump sizing and the performance of the system terminals/conditioners).

After any topping-up of water check the concentration and add glycol if necessary.

Water-glycol mixtures are used as the thermal carrier fluid in very cold climates or with temperatures below zero degrees centigrade.

Determine the % ethylene glycol which must be added to the water, using the following table:

(*) Values are for Clariant Antifrogen N. For different brands, check manufacturer's data.

For the water charges in the **HPC-W** circuit refer to *6.2 Water System*

If the buffer tank is installed on the machine, add the tank hydraulic volume.

To avoid stratification run the circulation pump for at least **30** minutes after adding any glycol.

After adding water to the hydraulic circuit always disconnected the water supply coming from the sanitary circuit; this avoids the danger of glycol entering the sanitary water circuit.

Water glycol fluid mixture has to be circulated inside the unit hydraulic parts including freecooling coils and by-pass pipes. In order to do it move the two 2-way valves on both positions for the time necessary.



NOTICE

Always charge the hydraulic circuit with the required glycol % necessary for the minimum ambient temperature of the installation site.

Failing to comply with this instruction shall invalidate the unit warranty.

Prevent freezing by draining

Otherwise drain the system completely, using the suitable shut-off valves arranged in the exchangers and in the circuit, trying to drain the water residues blowing air in the lines.

8.5 Electric System Specifications

Power supply requirements for the unit

- Check the electrical data on the label applied on the unit.
- Check that the available power supply is consistent with the unit power requirements given in 6.4 *Electrical System*.
- Refer to the electrical schematic supplied with the unit when making line voltage supply, low voltage main unit interlock and any low voltage alarm connections.

Local codes

- Electrical service must conform to national and local electrical codes.
- All wiring must be done in accordance with all applicable local, state, and national electrical codes.

Disconnecting switch and protection

- A manual electrical disconnect switch should be installed in accordance with local codes.
- Select and install the line side electrical supply wire and over current protection device(s) according to the specifications on the unit nameplate(s), per the instructions in this manual and according to the applicable national, state, and local code requirements.
- The customer is responsible for the system protection.
- Protect the system by a differential switch.
- If the system includes pumps with inverter, then use a type B or B** switch.

Power supply variability

- Check that the maximum unbalance between the phases does not exceed the value given in 6.4 *Electrical System*.
 - Make sure to comply with the following data:
 - Electrical voltage between 0.9 and 1.1 nominal voltage
 - Frequency between 0.99 and 1.01 the nominal frequency
 - Variability of supply voltage less than 2%
- See the figure below for variability evaluation.

Example of calculating phase to phase variability

- 1) The 400 V supply has the following variability:
 RS = 388 V
 ST = 401 V
 RT = 402 V

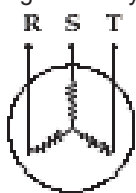

- 2) The average voltage is:

$$\frac{388 + 401 + 402}{3} = 397$$
- 3) The maximum deviation from the average is:

$$402 - 397 = 5 \text{ V}$$
- 4) The phase to phase variability is:

$$\frac{5}{397} \times 100 = 1.26 \text{ (acceptable)}$$

Power supply connection

The **Liebert® HPC-W** units are equipped with electrical devices (power supplies module, control devices, etc.) that are designed to operate properly with Star-connected power (Wye) with earthed neutral (TN or TT system).

Three-phase distribution Delta-connected (Δ) or Star-connected power (Wye) without ground or floating ground (IT) contact Vertiv™.

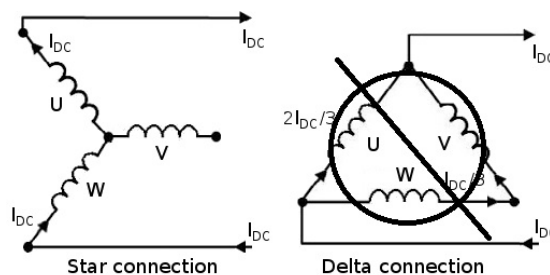

Power supply type

Acceptable:

- TT, TN-S, TN-C, TN-C-S systems
- 400V Wye with solidly grounded neutral (230V line to ground)

Unacceptable:

- 400 V Wye without ground connection or with high-resistance (or impedance) ground (IT).
- 400 V Δ without ground or with high-resistance (or impedance) ground (IT).
- 400 V Δ with corner ground or with grounded center-tapped.

Cables type

- Use copper wiring only.

The units are equipped with electrical panel with one main switch for the power section and one switch (option) for the control section.

Choose a supply cable (three- pole type with ground) for the power section and a supply cable (two-pole type with ground) for the control section (option)

according to:

- the local norms
- the system absorption (FLA unit)
- the system voltage
- installation type
- cable length
- upstream protection

Check integrity

- Make sure that all electrical connections are tight.
- Make sure that all electrical components are undamaged.

Sealing

- When leading the cable through the joint, you are recommended to use the sealant for waterproof disposal.
- If you do not follow the recommended cable sizes and mode to connect the cables, water leakage may occur at the waterproof joint.

Hot surfaces

- The cables cannot contact with hot objects, such as the copper pipe and water pipe without thermal insulation pipe, lest the insulation layers should be damaged.

8.6 Positioning

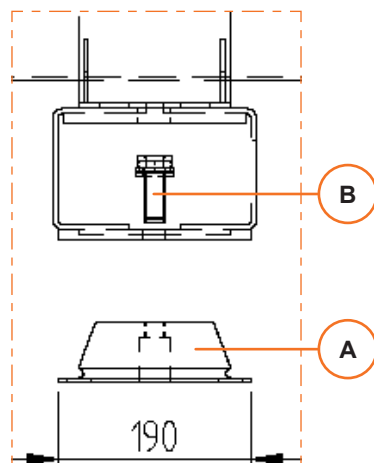
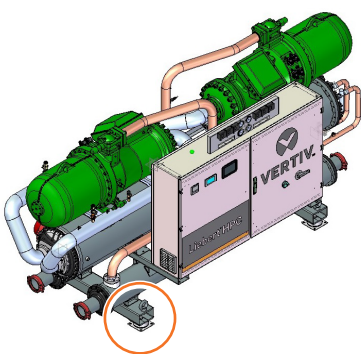

- Move the unit to the final position (see 7. Handling).
- Place the unit on a rubber mat or other insulating material.



NOTICE

Avoid to place the unit directly on the floor. The contact with concrete or other structure material may cause corrosion and vibration transmission.

You may mount the unit on anti-vibration supports (in rubber) that can be supplied as an option:

1. Place the anti-vibration supports [A] on the ground.
2. Lower the unit on them.
3. Fix the anti-vibration supports to the unit by the bolts [B].

8.7 Connections

8.7.1 Water system piping

Joints

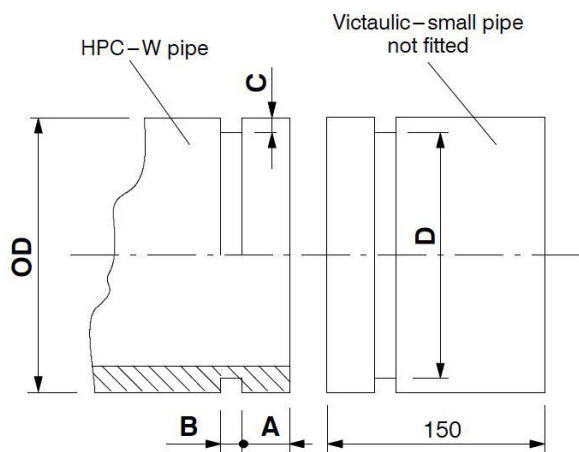

For welded hydraulic connection use the small pipes supplied with the unit, otherwise directly connect grooved lines with the grooved-type joints of the unit, taking care to suitably grease the joint gaskets.

Ref.	Unit	Dimensions				
OD (Ø)	Inch	4"	5"	6"	8"	10"
	DN	100	125	150	200	250
	mm	114,3	139,7	168,3	219,1	273,1
A	mm	15,88	15,88	15,88	19,05	19,05
Tolerance on A	mm	± 0,77	± 0,77	± 0,77	± 0,77	± 0,77
B	mm	9,53	9,53	9,53	11,13	12,7
Tolerance on B	mm	± 0,77	± 0,77	± 0,77	± 0,77	± 0,77
C	mm	2,11	2,13	2,16	2,34	2,39
D	mm	110,08	135,50	163,96	214,40	268,27
Tolerance on D	mm	- 0,51	- 0,56	- 0,56	- 0,64	- 0,69
	mm	+ 0,00	+ 0,00	+ 0,00	+ 0,00	+ 0,00

Condensers symmetrical circuits

The **Liebert® HPC-W** units have two condensers, one for each refrigerating circuit. Connect the lines to the heat disposal circuit symmetrically on each condenser, so as to ensure the same water delivery to each of them.

Vibration damping

Connect the water system piping to the **Liebert® HPC-W** by flexible joints to avoid transmitting vibrations and to balance the thermal expansion. Use flexible joints also for the pump assembly outside the **Liebert® HPC-W**. Isolate piping from the building using vibration isolating supports.

8.7.2 Electrical power supply

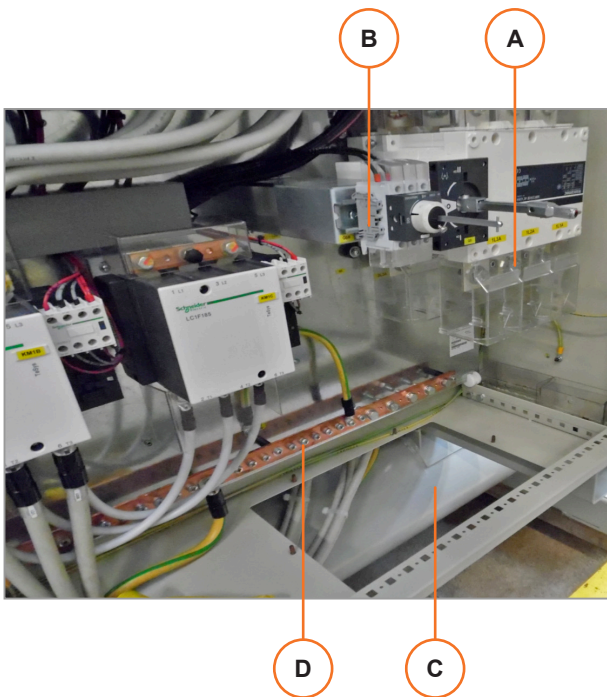

- A Power supply

- B Low voltage connection for the control system

- C Passage for cables

- D Protective Earth Connection

- After opening the passage in the structural works (precut), for the supply line inlet, restore the original protection degree with suitable accessories for the wiring and junction boxes.
- Install the cable avoiding carefully to touch the hot parts.
- Connect the cable to the inlet terminal board (disconnecting switch terminals for phases, ground bar for PE conductor).
- After having connected the cable, restore the protections against direct contacts.

The system/line cable protection is to be arranged by the customer.

Use a protection with differential switch.



NOTICE

The unit is equipped with its own microprocessor control adjustment. The use of the remote ON-OFF input (located in the electrical panel terminal board) as system temperature control element is forbidden

8.7.3 Ethernet cable connection

The control can be connected with a remote display through an Ethernet network cable (see Vertiv™ iCOM™ user Manual).

- Fasten the cable to the clamp-holding plates and make it pass through the first free hole on the panel bottom (arrange a cable clamp).
- After opening the passage in the structural works (precut), opposite the supply line inlet, restore the original protection degree with suitable accessories for the wiring and junction boxes.

The cable must be protected by a sheath.

8.7.4 Contacts for the unit status signals

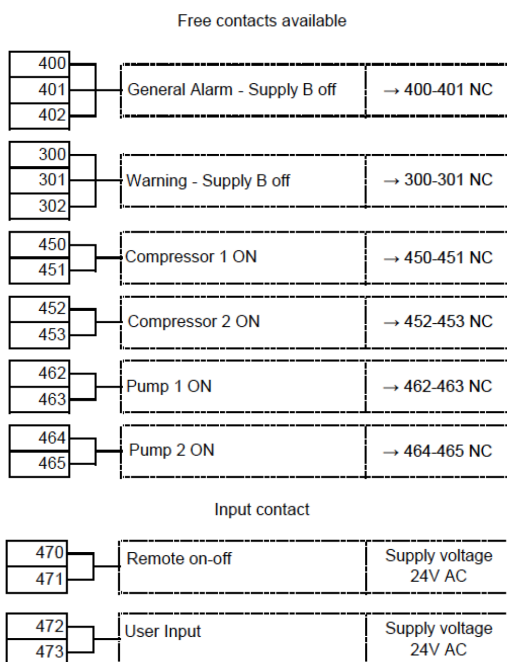

The clean contacts can be used only with PELV type sources, as described by the norm CEI EN 60204-1 “Safety of machinery - Electrical equipment of machines”.

The table on the left shows the available terminals and their meaning (refer to the wiring diagrams for further information).

- Fasten the cable to the clamp-holding plates and make it pass through the first free hole on the panel bottom (arrange a cable clamp).
- After opening the passage in the structural works (precut), opposite the supply line inlet, restore the original protection degree with suitable accessories for the wiring and junction boxes.

The cable must be protected by a sheath.

8.7.5 Pumps electrical connection

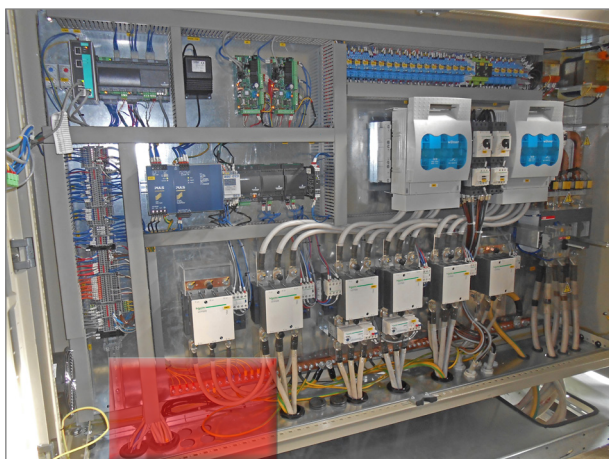

The customer is responsible for the pumps installation.

The electric box of the **HPC-W** unit contains contacts and cable glands available for the control and protection of the pumps.

- Connect the pumps wiring in accordance with all applicable local, state, and national electrical codes.
- Make reference to the *Electric Diagrams*.



NOTICE

The supply to the external pump assembly must be made before starting the refrigerating unit and must be kept on as long as the unit is in use.

Incorrect operation will cause the unit to lock out because of the internal protections (flow switch intervention).

8.7.6 Instrumentation connection

- Make reference to the *Electric Diagrams*.

8.7.7 Safety valves discharge

Convey the discharge

On the refrigerating circuit safety valves are installed on the high and low pressure sides: the discharge of these valves must be conveyed outside through a suitable pipe, having a diameter of at least that of the valve discharge, without burdening the valve body.

Convey the discharge to areas where the jet cannot harm people.

8.8 Filling the Water System

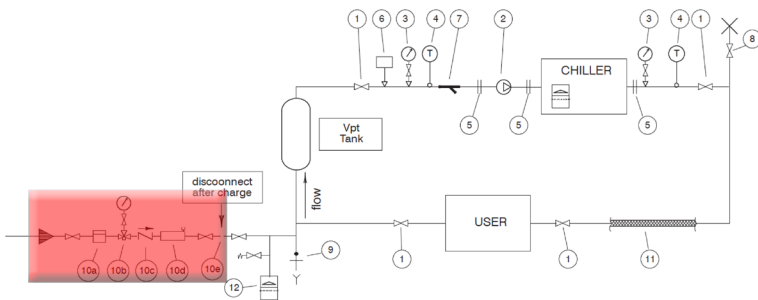

- Supply water through the fill group. See 8.4 *Water System Specifications* for the amount of water to charge.
- In case of low ambient temperature, add glycol: see 8.4.6 *Prevent freezing*
- To avoid stratification, run the circulation pump for at least 30 minutes after adding any glycol.
- At the end of the filling operation, disconnect the water supply tube.
- After any topping-up of water check the concentration of the glycol if necessary.



NOTICE
Always charge the hydraulic circuit with the required glycol percentage necessary for the minimum ambient temperature of the installation site. Failing to comply with this instruction shall invalidate the unit warranty.



NOTICE
Do not exceed the nominal operating pressure of the circuit's component.

8.9 Initial Checks

NOTE
Follow this instructions at first start-up and also in case of restart after a long stop.

NOTE
Record the functional data on the *Start-Up certificate*.

Electrical system



WARNING
Disconnect the power supply before doing the following checks on the electric system as explained in 8.2 *Safety Instructions*.

- Check all the cable connections particularly the main power connections on the power fuses and contactors.
- Check that all thermal protections are calibrated according the electrical data tables reported on wiring diagram.

Refrigerating system

- Open the discharge valve (and the suction valve, if installed) of the compressor and the shut-off valve on the liquid line.
- Open the valves of the refrigerating circuit that had been closed before the initial check.

Water system

- Check all water connections.
- Open all isolating valves and/or water ball valve.
- In case of climates with temperatures below zero degrees C, make sure the chilled water circuit is filled with the correct concentration of water/glycol, see 8.4.6 *Prevent freezing*
- Bleed all air out of the chilled water circuit.
- Verify the water flow rate and its direction.
- Ensure that the thermal load is sufficient for start-up.
- Start the pumps, check that they rotate in the correct direction and that the signal of the flow switch has been wired according to the wiring diagram.

Covers and seals

- Make sure that all the protective covers and seals have been mounted again.

Replace the cartridge of the driers

At first start-up is recommended to replace the cartridge of the driers, see *Cartridge of the driers*.

Everything OK?

Power-up and prepare for normal operation: see *Operation*

9. Operation

9.1 Safety Instructions

Personnel



WARNING

The operation has to be done by a qualified technician with an experience and know-how on units, Vertiv™ iCOM™ control board and software.

The authorized personnel must be properly trained and qualified, wear appropriate personal protective equipment and use adequate tools.

Electric System



NOTICE

The power supply should never be disconnected during normal operation, except when performing maintenance (see *Maintenance*).

Personal Protective Equipment



Environment



ENVIRONMENT

A misuse or an incorrect calibration of the unit leads to increased energy consumption, resulting in an economic and environmental damage.

See *Calibrations* and make reference to the *VERTIV™ iCOM™ User manual* for correct parameter settings.

9.2 Power-up

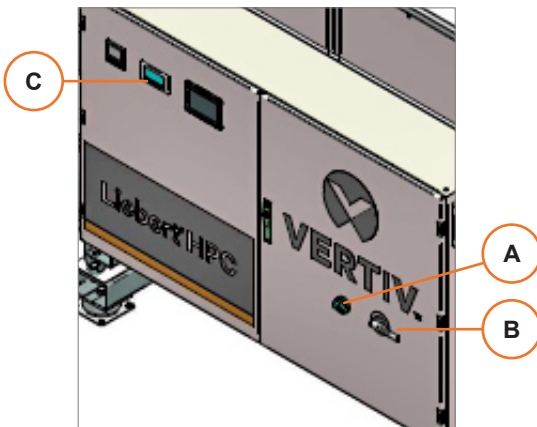

1. Close the disconnection device upstream the **Liebert® HPC-W**.
2. Close the main switch **[A]**
3. Set the general knife switch **[B]** to the position “I”.

- Check that the Vertiv™ iCOM™ display **[C]** switches on.
- In case of first start-up or after maintenance on the electric system, check again by a voltmeter or tester if the voltage and phase difference fall within the indicated limits.

9.3 Preparation

NOTE

Follow this instructions at first start-up and also in case of restart after a long stop.

Compressor pre-heating and check

When you set the general knife switch **[B]** to the position "I", the compressor crankcase heaters are automatically powered **ON**.



NOTICE

The pre-heating of the compressor crankcase takes about **8** hours.

- Remember to power up the unit well in advance before starting the normal operation.

- Make sure the auxiliary circuit has been powered and check the operation (a fault due to an incorrect procedure will invalidate the compressor guarantee).

At the end of the pre-heating:

- check that all the valves the refrigerating circuit are open
- check that the intake pressure is higher than 7.0 bar

If this is not the case, prolong the pre-heating of the compressor and check that the refrigerant EEV valve is properly closed.

Water system

- Check the evaporator water system, which is the thermal load connected with the **Liebert® HPC-W**.
- Start the evaporator and condensers pumps.

To avoid an increase in the water temperature inside the evaporator and condenser, with the risk of deposit formation:

- when you are going to start the **Liebert® HPC-W** unit, start the pumps in advance
- when you stop the **Liebert® HPC-W** system, let the pumps run for a while

9.4 Start

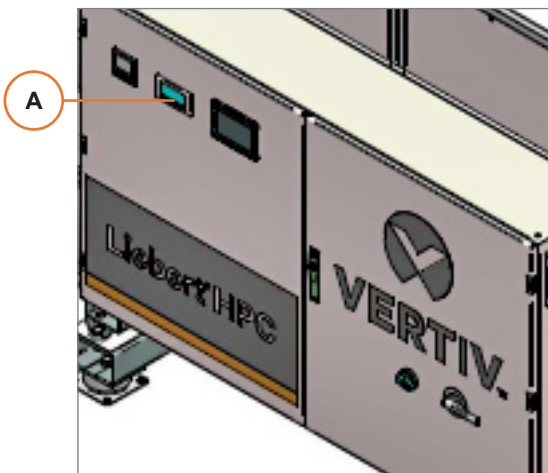

NOTICE

Before starting the unit, make sure that the compressor has been heated for at least **8** hours.

- On the Vertiv™ iCOM™ control panel **[A]** set the switch to **ON**.

9.5 Check the Operation



NOTICE

The following checks must be done:

- at first start-up
- in case of restart after a long stop
- at time intervals during the normal operation

Protection	Check the flow switch operation (installed by the customer)
Flow-switch	<ul style="list-style-type: none"> • close the shut-off valve downstream the evaporator till the flow switch intervenes • check if, without flow, the Liebert® HPC-W locks and the alarm message is displayed • open again the shut-off valve downstream the evaporator
Alarms	• Make sure that all the alarms due to protective devices interventions have been reset (see <i>VERTIV™ iCOM™ User Manual</i>)
Water temperature	<ul style="list-style-type: none"> • Check the outlet temperature of the chilled water. • Check if the set-point set on the control is reached. <p>NOTE <i>During the unit start-up a temperature of the water/ glycol inlet higher than 26°C is allowed.</i></p> <ul style="list-style-type: none"> • Under standard operating conditions check that the limits indicated in <i>6.3 Operating Limits</i> are not exceeded.
Control and safety devices	• Check the correct operation of the control and safety devices.
Compressor	<ul style="list-style-type: none"> • Check the compressor oil level. See <i>Oil charge</i> if you need to top-up the oil. • With the compressor at full load, check there are no bubbles visible in the flow indicator. If there are any, charge the unit according to <i>Refrigerant charge</i>.

9.6 Stop

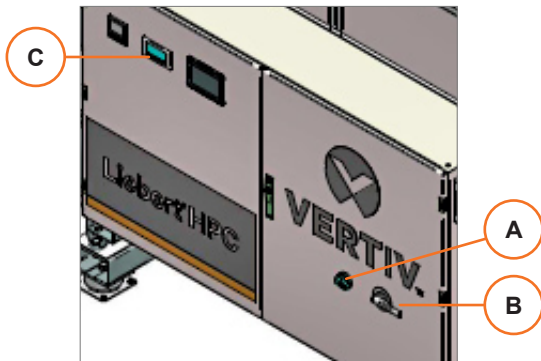

- On the Vertiv™ iCOM™ control panel [A] set the switch to **OFF**.

In case of a short stop:

- Maintain the general knife switch [B] to the position “I” to maintain the supply to the crankcase heater.

In case of a long stop (seasonal shutdown):

1. Set the general knife switch [B] to the position “I”. This will disconnect the compressor crankcase heaters.
2. Close the main switch [A]
3. Close the disconnection device upstream the **Liebert® HPC-W**.

9.7 Restart

After a short stop	• On the Vertiv™ iCOM™ control panel [A] set the switch to ON (as in <i>9.4 Start</i>).
After a long stop	Do the complete procedure as described in: <i>9.2 Power-up, 9.3 Preparation, 9.4 Start</i>
In case of power blackout	<p>If the power blackout is shorter than a certain time, the Liebert® HPC-W restarts automatically. The time limits are:</p> <ul style="list-style-type: none"> - up to 4 hours without Fast Start Ramp Option - up to 1 hour with Fast Start Ramp Option <p>If the power blackout is longer the Liebert® HPC-W needs a manual restart:</p> <ul style="list-style-type: none"> • on the Vertiv™ iCOM™, clear the alarm message due to the power fault • repeat the procedure of the previous point <i>After a long stop</i>

10. Maintenance



NOTICE

Check the unit regularly and solve the problems as they occur.
Lack of maintenance could reduce the performance or damage the unit.

10.1 Safety Instructions

Personnel



WARNING

Only authorized personnel is allowed to do maintenance operations.
All work on pipes or components of the refrigerating circuit under pressure must be exclusively made by qualified staff, competent in such works.
The authorized personnel must be properly trained and qualified, wear appropriate personal protective equipment and use adequate tools.

Electric System



WARNING

Unit contains potentially lethal voltage in some circuits.

Risk of arc flash and electric shock. Can cause injury or death.

- Open all local and remote unit electric power disconnect switches, verify with a voltmeter that power is **OFF** and wear protective equipment per local standard before working within the electric control enclosure.
- It is forbidden to operate on the electrical components without using insulating platforms, or in the presence of water and humidity.



WARNING

The electric connection enclosures and some components can retain a stored high-voltage electrical charge for up to **10** minutes.

Risk of electric shock. Can cause serious injury or death.

Before working within the unit electric connection enclosures proceed as follows:

- open all local and remote unit electric power disconnect switches
- wait **10** minutes
- verify with a voltmeter that power is **OFF**

Only properly trained and qualified personnel may perform repair, maintenance and cleaning.

Lockout-Tagout (LOTO)



WARNING

Before any intervention on the electrical system or accessing the inner components:

- Lock the disconnection device by a padlock or similar tool.
- Apply on the general knife switch a suitable warning plate for no operation.

High temperature



CAUTION

The front part of the compressor and the delivery pipe and the condenser are very hot.

- Be careful when operating nearby.
- Always wear temperature resistant gloves when operating on the unit.

Safeguards



CAUTION

After the maintenance interventions, always close the unit by refitting the relevant panels, if present, fastened by the fixing screws.

PPE



CAUTION

Sharp edges, splinters and exposed fasteners.

Wear protective gloves before operating on the unit.

10.2 Safety Labels

- Check regularly that the safety label are still on the unit and clearly visible. See *Annex III – Safety Labels* for safety label mapping. Replace any missing or damaged label.

10.3 Spare parts

The use of original spare parts is recommended.

When placing an order refer to "Component List" enclosed with the machine and quote the unit model and serial number.



NOTICE

If one or more compressors must be replaced, you must contact Vertiv™ Service.

10.4 Maintenance programme

The Maintenance Programme below must be carried out by a qualified technician, preferably working under a maintenance contract.

Control	<ul style="list-style-type: none"> • Check that the control equipment, LEDs and display are operating correctly. • Check the supply voltage. • Check the operation of the compressor's oil heaters. • Check the correct operation of the compressors' partialization solenoid valves. • Check the conditions of the power contacts of the contactors (compressors, pumps, etc.). • Check the conditions of the remote control switch contacts. • Check the operation of the evaporator resistance (if present).
Electrical circuit	<ul style="list-style-type: none"> • Check the electrical supply on all phases. • Ensure that all electrical connection are tight. • Check the correct calibration of the safety and control devices (see <i>10.7 Calibrations</i>), as well as their proper intervention.
Refrigeration circuit	<ul style="list-style-type: none"> • Check the condensing and the evaporating pressure (to be done by a refrigeration technician). • Check the compressor current absorption, the delivery temperature and possible unusual noises. • Check the refrigerant charge by mean of the sight glass. • Check that the safety device operate correctly. • Check the correct operation of the EEV valve (superheat between 5-8°C, see <i>10.7.2 Electronic expansion valve</i>). • Check that the oil level indicated by the compressor sight glass is higher than the min value. • Check the sealing of the ON-OFF component (solenoid valves, shut-off valves, etc.)
Water circuit	<ul style="list-style-type: none"> • Ensure that there are no water leaks. • Bleed any air out of the hydraulic circuit using the bleed valve. • Verify the correct water flow inlet. • Check the inlet-outlet water temperature and pressure. • Check the correct operation of the two-way valves. • Check if the system is charged with the specified glycol percentage and that no ice has formed in the hydraulic circuit. • Check the evaporator and the condenser cleanliness.

10.5 Panels Opening (Low Noise Version)

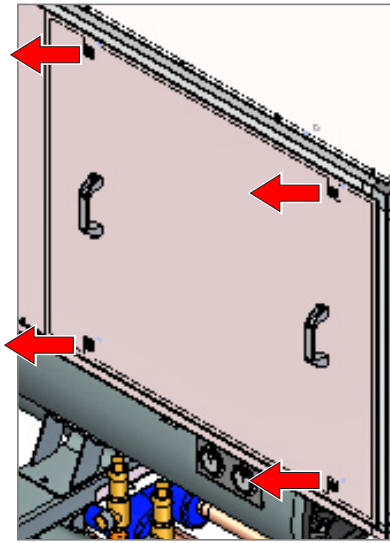

1. Disconnect the power supply before working on the unit.
2. Loosen the fixing screws.



CAUTION

While you loose the screws, push on the panel to avoid that it falls suddenly.



3. Grasp the panel by the handles.
4. Pull the panel slightly on the side and remove it.

10.6 Refrigeration System

10.6.1 Inspection

- Check that the refrigeration pipes are firmly fixed. The refrigeration pipes shall not shake with the vibration of wall, earth or equipment frame. Otherwise reinforce the refrigeration pipes with fasteners.
- Check that there is no oil on the accessories of all refrigeration pipes, and make sure that the pipes do not leak.

10.6.2 Refrigerant charge

Before shipment each unit is charged with the right amount of refrigerant and oil.

You may need to do again the refrigerant charge in case of interventions on the refrigerating circuit.



NOTICE

Never use the compressor for the system vacuum (this invalidates the warranty).



NOTICE

It is important to carry out charging correctly.

An excess of refrigerant causes an increase in sub-cooling and consequent operating difficulties in the hot season.

A shortage of charge generates an increase in superheating and possible compressor stoppages.

Whenever work is carried out on the unit, ensure afterwards that the working conditions are correct, checking sub-cooling and superheating.



ENVIRONMENT

While repairing the refrigerating circuit recover all the refrigerant in a container: do not allow it to escape.

Before starting the refrigerant charge	<ul style="list-style-type: none"> • Ensure there are no water leaks. • Check the refrigerant charge in the refrigerating circuit: a unit originally charged by the manufacturer with a certain refrigerant cannot be charged with other refrigerant. • Apply to the Technical Support Department if you need more information.
Do the charge	<ul style="list-style-type: none"> • Charge with the compressor in operation, by connecting the gas cylinder with the charge connector after the thermostatic expansion valve. • Drain the connection pipe between the cylinder and the charging point; tighten the seal joint and then start charging the unit. • It is imperative that the cylinder is weighed both before and after the operation. • Charge the unit until the bubbles in the sight glass have disappeared and the working conditions of the entire refrigeration circuit have returned to normal (sub-cooling and superheating within the limits indicated below).
Measure the superheat	<ul style="list-style-type: none"> • Detect the temperature on the suction line, close to the bulb of the thermostatic expansion valve, using a contact thermometer. • Connect a pressure gauge (by max a 30 cm pipe) with the Schraeder connection and read the corresponding saturated evaporating temperature. • The superheat is the difference between the two readings. • Verify that the superheat is 4-8°C.
Measure the sub-cooling	<ul style="list-style-type: none"> • Detect the temperature on the liquid line using a contact thermometer. • Connect a pressure gauge (by max a 30 cm pipe) with the Schraeder connection on the liquid line and read the corresponding saturated condensing temperature. • The sub-cooling is the difference between the two readings. • Verify that at the condenser outlet, sub-cooling is 4-8°C.
Check the oil level	Let the compressors run for a short time, then check the oil level for each compressor.

Check the operating conditions

With the pressure gauges connected, check

- the working pressures

and that:

- the evaporation temperature is lower than the water temperature exiting the evaporator,
- the condensing temperature is higher than the water temperature exiting the condenser.

For a correct system testing, also check the compressor discharge temperature:

- with the indicated over-heating and sub-cooling data, it must be about 20-25°C higher than the condensing temperature
- it must never exceed 95-100°C

10.6.3 Oil charge

Before shipment each unit is charged with the right amount of refrigerant and oil.

If there has been any loss of oil then this must be topped up as follows.



NOTICE

The oil changes according to the type of used refrigerant.

Contact the Technical Support Department for the specifications of the oil to be used for topping up.

Top-ups of up to 20-30% of the total amount of oil contained in the compressor crankcase are permitted; for larger percentages contact the technical support department.



NOTICE

Never mix different oils together.

Clean the piping completely before changing the type of oil used.

Prepare the oil

- Take a clean, dry, transparent container (with volume calibrations) and fill it with at least twice the amount of oil required.

Prepare the compressor

- Isolate the compressor by closing the delivery and suction shut-off valves (or the one on the liquid line).
- Connect to the fittings on the compressor body (Schraeder valves) and empty it of refrigerant until atmospheric pressure (1 bara) is reached.

Refill with oil

- Using a pipe, connect the oil container to the oil service shut-off valve on the lower central part of the compressor.
- Open the oil service shut-off valve lifting the container, so that the oil flows by gravity.
- Charge the required quantity of oil (make sure the tube always remains below the oil level).

Restore the compressor operation

- Close the oil service shut-off valve.
- Open the shut-off valves of the compressor and on the refrigerating circuit.
- Restore the drained refrigerant charge (see *10.6.2 Refrigerant charge*).

10.6.4 Compressor maintenance schedule - checks and tests

Compressor reverse direction	<p>To protect against reverse rotation when stopped, a check valve is incorporated under the compressor's delivery valve.</p> <p>If the compressor runs in reverse direction for more than 5 sec. after switch-off, the valve may be damaged and should be replaced.</p>
Periodic check	Check the correct functioning every 5000 compressor working hours.
Bearings	<p>Screw compressors are equipped with fatigue resistant bearings, therefore replacement is not necessary provided that the refrigerant circuits are operated under standard conditions within the operating limits and respecting the indicated maintenance schedule.</p> <p>Bearing wear detection is to be carried out by sound analysis.</p> <p>The recommended inspection interval is every 10.000 compressor working hours.</p> <p>For preventive maintenance, the recommended interval for replacing the bearings is every 40,000 working hours of the compressors.</p> <p>Anyway, under the standard operating conditions of the Liebert® HPC-W units (resulting from the air-conditioning application where the condensation is mainly lower than 50°C in one operating year) the life limits of the bearings are not reached.</p> <p>Due to occasional variations of the compressor standard operating conditions, such as: lack of oil, moisture in the refrigerant, insufficient superheating or thermal overload, the bearings may need to be replaced.</p> <p>Please contact our Service department if it's necessary to replace the compressor's bearings: Only authorized service centers are authorized to open the screw compressor.</p>
Motor	<p>It is important to check the motor wear by measuring the resistance of the insulation of its windings.</p> <p>The recommended inspection interval is every 10.000 compressor working hours.</p>

10.6.5 Cartridge of the driers

Replace the cartridges

Liebert® HPC-W is equipped with a shut-off valve on the liquid line downstream of the refrigerant filter (see the *Electric Diagrams*).

- Close the shut-off valve.
- Replace the cartridges.
- **Open the shut-off valve!**



NOTICE

The shut-off valve must always remain open, during transport and storage too.

The shut-off valve must be closed exclusively:

- to remove the cartridges during maintenance operations
- during the dry run on the components (e.g. compressors, valves/solenoid valves, EEV, etc.)



ENVIRONMENT

The used cartridges are hazardous waste and must be disposed according with the local norms in force.

10.7 Calibrations



ENVIRONMENT

A misuse or an incorrect calibration of the unit leads to increased energy consumption, resulting in an economic and environmental damage.

10.7.1 Safety devices

The **Liebert® HPC-W** has been already tested and calibrated by the manufacturer.
The following setting values are used for R134a/R513A:

Component	Settings for WH models	Settings for WHT models
Safety valves	High Pressure Side (HP): 22 barg Low Pressure Side (LP): 14 barg	High Pressure Side (HP): 22 barg Low Pressure Side (LP): 14 barg
High pressure switches	STOP: 14 barg START: 10 barg DIFF.: 4 barg (fixed)	STOP: 20 barg START: 16 barg DIFF.: 4 barg (fixed)
Low Pressure switches (*)	STOP: 1,1 barg START: 1,2 barg DIFF.: 0,1 barg	STOP: 1,1 barg START: 1,2 barg DIFF.: 0,1 barg

Note (*) *The low pressure side is managed by electronic control Vertiv™ iCOM™, not by electromechanical devices.*

10.7.2 Electronic expansion valve

The valve has already been factory-set and superheat should be reset only when it's not between 5°C and 8°C or it's present oil foam (visible on compressor's oil sight glass).



NOTICE

This operation must be performed by an experienced refrigeration technician.



NOTICE

Stop the relevant compressor before changing the EEV superheat setpoint.

Preparation	Before beginning this calibration be sure that the refrigerant charge is correct: do the subcooling measurement as specified in <i>10.6.2 Refrigerant charge</i> .
Setting	Compressor's suction pressure, temperature and superheat can be read on Vertiv™ iCOM™ control display as described in the suitable <i>Vertiv™ iCOM™ User Manual</i> available on the machine. Use Vertiv™ iCOM™ for resetting the superheat.
Note	If the superheat is too low, there is a risk of poor lubrication and consequent breakage of the compressor as a result of pressure shock If the superheat is too high the output of the system is limited and the compressor overheats.

10.7.3 Chiller serving special plant

The units are capable of cooling a water-glycol mixture to temperatures close to 0°C without the need for significant modifications. In the case of modification, the set values of the safety and control components must also be modified.
This can be carried out in the factory (at the time of testing) or at the time of installation, only by qualified and authorised personnel.

10.8 Water System

Glycol

In winter, if the system is stopped, the water inside the exchangers can freeze damaging the system irreparably.

See 8.4.6 *Prevent freezing*



NOTICE

Always charge the hydraulic circuit with the required glycol % necessary for the minimum ambient temperature of the installation site.

Failing to comply with this instruction shall invalidate the unit warranty.

Draining

Otherwise drain the system completely, using the suitable shut-off valves arranged in the exchangers and in the circuit, trying to drain the water residues blowing air in the lines.

10.8.1 Cleaning

Exchangers cleaning may be performed only with chemical method, using commercially available products with a dual action, that is, the removal of the scale and the prevention of corrosion.

A recommended product is P3 T288 by Henkel.

11. Troubleshooting

Symptom	Possible Cause	Check or Remedy
The unit does not start	No power supply to the unit	Check voltage at input terminal block
	The circuit breaker or fuse for low-voltage transformer in unit is tripped	Locate the problem in unit electrical panel and repair
Low evaporating pressure	Low refrigerant charge	Check refrigerant charge
	EEV problem	Check EEV configuration
	High pressure drop on the liquid line	Check shut-off valve, filter drier...
High condensing pressure	High refrigerant charge	Check refrigerant charge
	Problem with condensing control valve	Check condensing control valve
The compressor does not run or does not run properly	Flow switch not responding	Check the flow switch
	The connection is loose or disconnect	Check the connection to verify that is connected securely
	The compressor doesn't modulate capacity properly	Check the solenoid valves
	The high pressure switch has shut-off the unit	Check the high pressure switch
High vibration on the unit	The compressor is not properly fixed	Check the compressor dampers
	The discharge and suction piping are not properly fixed	Check the piping
	The unit damper (if installed) is not properly fixed	Check the unit damper
	The unit is not properly connected to the hydraulic circuit	Check the joint connection

12. Dismantling the Unit

The unit has been designed and built to ensure continuous operation. The working life of some of the main components, such as the compressors, depends on the maintenance that they receive. The unit must be dismantled if it is moved to another site, or at the end of its technical and operational life.



ENVIRONMENT

The unit contains substances and components hazardous for the environment (electronic components, refrigerating gases and oils).

At the end of the useful life, when the unit is dismantled, the operation must be carried out by specialized refrigerating technicians.

The unit must be delivered to suitable centers specialized for the collection and disposal of equipment containing hazardous substances.

The electronic components, the refrigeration fluid and the lubricating oil inside the circuit must be recovered according to the laws in force in the relevant country.

12.1 Safety Instructions

Personnel



WARNING

Only authorized personnel is allowed to do dismantling operations. All work on pipes or components of the refrigerating circuit under pressure must be exclusively made by qualified staff, competent in such works. The authorized personnel must be properly trained and qualified, wear appropriate personal protective equipment and use adequate tools.

Electric System



WARNING

Unit contains potentially lethal voltage in some circuits. **Risk of arc flash and electric shock. Can cause injury or death.**

- Open all local and remote unit electric power disconnect switches, verify with a voltmeter that power is **OFF** and wear protective equipment per local standard before working within the electric control enclosure.
- It is forbidden to operate on the electrical components without using insulating platforms, or in the presence of water and humidity.



WARNING

The electric connection enclosures and some components can retain a stored high-voltage electrical charge for up to **10** minutes. **Risk of electric shock. Can cause serious injury or death.**

Before working within the unit electric connection enclosures proceed as follows:

- open all local and remote unit electric power disconnect switches
- wait **10** minutes
- verify with a voltmeter that power is **OFF**

Only properly trained and qualified personnel may perform repair, maintenance and cleaning.

Lockout-Tagout (LOTO)



WARNING

Before any intervention on the electrical system or accessing the inner components:

- Lock the disconnection device by a padlock or similar tool.
- Apply on the general knife switch a suitable warning plate for no operation.



PPE



CAUTION

Sharp edges, splinters and exposed fasteners. Wear protective gloves before operating on the unit.

12.2 Operations

Operation	Notes
1. Disconnect the main switch from the electric power supply	Reverse the procedure from chapter 8. <i>Installation: 8.7.2 Electrical power supply</i>
2. Discharge the water	Reverse the procedure from chapter 8. <i>Installation: 8.7.1 Water system piping</i>
3. Remove the refrigerant	 <p>NOTICE Handle the refrigerant according to regulations about F-Gases and safety data sheet. See <i>Regulation (EU) no. 517/2014 (F- gas)</i></p>
4. Cut the piping at inlet and outlet of the unit	 <p>WARNING Before cutting the pipeline, make sure that the circuit is completely discharged.</p>
5. Remove the fixing bolts	Reverse the procedure from chapter 8. <i>Installation: 8.6 Positioning</i>
6. Move away the unit	See 7. <i>Handling</i>
7. If you need to keep the unit in a storehouse for reuse	See 7.3 <i>Storage</i>
8. If you need to scrap the unit	Handle to authorized disposal company according to the local regulations about waste disposal.

13. Regulation (EU) no. 517/2014 (F- gas)

13.1 Introduction

Stationary air conditioners placed into the European Community market and operating with fluorinated greenhouse gases (F-gas, such as R407C, R134a, R513A, R410A), have to comply with the F-gas Regulation (EU) No. 517/2014.

This Regulation is in force since Jan 1, 2015 and it replaces the Re. (EU) no. 342/2006.

This document summarizes the obligations for the operators that are responsible for the equipment during all its operative life until its disposal.

13.2 Normative References

F-gas	517/2014	Regulation (EU) No 517/2014 of the European Parliament and of the Council of 16 April 2014 on fluorinated greenhouse gases and repealing Regulation (EC) No 842/2006
Certified personnel and Companies	2015/2067	Commission Implementing Regulation (EU) 2015/2067 of 17 November 2015 establishing, pursuant to Regulation (EU) No 517/2014 of the European Parliament and of the Council, minimum requirements and the conditions for mutual recognition for the certification of natural persons as regards stationary refrigeration, air conditioning and heat pump equipment, and refrigeration units of refrigerated trucks and trailers, containing fluorinated greenhouse gases and for the certification of companies as regards stationary refrigeration, air conditioning and heat pump equipment, containing fluorinated greenhouse gases
Leak check air conditioning	1516/2007	Commission Regulation No 1516/2007 of 19 December 2007 establishing, pursuant to Regulation (EC) No 842/2006 of the European Parliament and of the Council, standard leakage checking requirements for stationary refrigeration, air conditioning and heat pump equipment containing certain fluorinated greenhouse gases
Leak check fire protection systems	1497/2007	Commission Regulation No 1497/2007 of 18 December 2007 establishing, pursuant to Regulation (EC) No 842/2006 of the European Parliament and of the Council, standard leakage checking requirements for stationary fire protection systems containing certain fluorinated greenhouse gases

From 01/01/2017 to be replaced by:

Commission Implementing Regulation (EU) 2015/2068 of 17 November 2015 establishing, pursuant to Regulation (EU) No 517/2014 of the European Parliament and of the Council, the format of labels for products and equipment containing fluorinated greenhouse gases

13.3 Fluorinated Greenhouse Gases

Following notes have to be considered when operating with the above mentioned equipments:

- Fluorinated greenhouse gases are covered by the Kyoto Protocol.
- The fluorinated greenhouse gases in this equipment should not be vented to the atmosphere.
- Referring to the value noted in Annex I and Annex IV of Regulation (EU) No 517/2014 here below the global warming potential (GWP) of some major F-gases or mixtures:
 - R-513A GWP: 631
 - R-134a GWP 1430
 - R-407C GWP 1774
 - R-410A GWP 2088

NOTE: *the refrigerants as R22 are not F-gas and their relevant regulation is Reg. (EU) no. 1005/2009.*

13.4 Operators

13.4.1 Definitions

- Operator, according to Regulation 517/2014 Article 2, point 8, means the natural or legal person exercising actual power over the technical functioning of products and equipment covered by this Regulation.
- The State may, in defined, specific situations, designate the owner as being responsible for the operator's obligations.
- Where large installations are involved, service companies are contracted to carry out maintenance or servicing. In these cases the determination of the operator depends on the contractual and practical arrangements between the parties.

13.4.2 Obligations

Operators of stationary air conditioners, which contain fluorinated greenhouse gases, shall, using all measures which are technically feasible and do not entail disproportionate cost:

- Prevent leakage of these gases and as soon as possible repair any detected leakage.
- Ensure that they are checked for leakage by certified personnel.
- Ensure for putting in place arrangements for the proper recovery by certified personnel.
- According to Regulation 517/2014 the operators shall ensure that the equipment is checked for leaks as following:
 - Case 1** - Non-sealed equipment contains less than 5 tonnes of CO₂ equivalent of fluorinated greenhouse gases.
 - ▶ Leakage test not required
 - Case 2** - Hermetically sealed equipment contains less than 10 tonnes of CO₂ equivalent of fluorinated greenhouse gases.
 - ▶ Leakage test not required
 - Case 3**
 - ▶ **Leakage test required:** check the equipment for leaks with the minimum frequency given in the following table:

X = Tonnes of CO ₂ Equivalent	Y = equivalent amount of refrigerant [kg]				Minimum frequency for leak check	
	R513A	R134a	R410A	R407C	with leakage detection	without leakage detection
$5 \leq X < 50$	$7,9 \leq Y < 79$	$3,5 \leq Y < 35$	$2,4 \leq Y < 24$	$2,8 \leq Y < 28$	12 Months	24 Months
$50 \leq X < 500$	$79 \leq Y < 790$	$35 \leq Y < 350$	$24 \leq Y < 240$	$28 \leq Y < 282$	6 Months	12 Months
$X \geq 500$	$Y \geq 790$	$Y \geq 350$	$Y \geq 240$	$Y \geq 282$	3 Months	12 Months

- Recovery for the purpose of recycling, reclamation or destruction of the fluorinated greenhouse gases, pursuant to Art. 8 of the Regulation 517/2014 shall take place before the final disposal of that equipment and, when appropriate, during its servicing and maintenance.

13.5 Leakage Detection

The manufacturer approves the following leakage check methods according to Reg. 1516/2007 and Reg. 1497/2007:

Method	Specifications
a Check of circuits and components representing a risk of leakage with gas detection devices adapted to the refrigerant in the system	Gas detection devices shall be checked every 12 months to ensure their proper functioning. The sensitivity of portable gas detection devices shall be at least five grams per year.
b Application of ultraviolet (UV) detection fluid or suitable dye in the circuit	The method shall only be undertaken by personnel certified to undertake activities which entail breaking into the refrigeration circuit containing fluorinated greenhouse gases.
c Proprietary bubble solutions/soapsuds	---

13.6 Labelling

The label applied on the unit (see *Onboard Label*) is designed to fill-in the relevant amounts of refrigerant according to Regulation 1494/2007 (2015/2068):

- a Where fluorinated greenhouse gas is foreseen to be added to the equipment outside of the manufacturing site at the point of installation, a dedicated label accommodates notation of both the quantity [kg] pre-charged in the manufacturing plant and of the quantity charged at the installation site as well as the resulting total quantity of F-gas as a combination of the above mentioned quantities, in a manner which conforms to the legibility and indelibility.

Our split units are usually not pre-charged on factory, in this case the total quantity of refrigerant charged in the unit has to be written in the relevant label, during the commissioning operation at the installation site.

All of the quantities of must be given both as mass of refrigerant [kg] and as Tonnes of CO2 Equivalent.

Use the following rule for computation:

$$\text{Tonnes of CO2} = \frac{\text{kg of refrigerant} \times \text{GWP of refrigerant}}{1000}$$

where:

Refrigerant	GWP
R-513A	631
R-134a	1430
R-407C	1774
R-410A	2088

- b Our packaged units (not split) operating with f-gas are usually full charged on factory and the total amount of refrigerant charge is already reported on the label. In this case, the label has no need of further written information.
- c In general, the above mentioned information has been located in the main nameplate of relevant unit.
- d For equipment with double refrigeration circuits, in regards to differentiates requirements on the basis of the quantity of F-gas contained, the required information about refrigerant charge quantities has to be listed separately for each individual circuit
- e For equipments with separate indoor and outdoor sections connected by refrigerant piping, the label information will be on that part of the equipment which is initially charged with the refrigerant. In case of a split system (separate indoor and outdoor sections) without a factory pre-charge of refrigerant, the mandatory label information will be on that part of the product or equipment which contains the most suitable service points for charging or recovering the fluorinated greenhouse gas(es).

NOTE: *Safety data sheets of F-gases used in the products are available on demand.*

13.7 Record Keeping

Operators of equipment which is required to be checked for leaks (see *13.5 Leakage Detection*), shall establish and maintain records for each piece of such equipment specifying the following information:

- a the quantity and type of fluorinated greenhouse gases installed
- b the quantities of fluorinated greenhouse gases added during installation, maintenance or servicing or due to leakage
- c whether the quantities of installed fluorinated greenhouse gases have been recycled or reclaimed, including the name and address of the recycling or reclamation facility and, where applicable, the certificate number
- d the quantity of fluorinated greenhouse gases recovered
- e the identity of the undertaking which installed, serviced, maintained and where applicable repaired or decommissioned the equipment, including, where applicable, the number of its certificate
- f the dates and results of the leak checks carried out (see *13.5 Leakage Detection*)
- g if the equipment was decommissioned, the measures taken to recover and dispose of the fluorinated greenhouse gases

Unless the records are stored in a database set up by the competent authorities of the Member States the following rules apply:

- a the operators shall keep the records for at least **five** years
- b undertakings carrying out activities for operators shall keep copies of the records for at least **five** years

Annex I – Dimensions and Weights

Weights

WHT model

Model	WHT2131: WH2131/051584. Order n° 65601914
Net Weight [kg]	7520
Weight included water [kg]	8750

Dimensions

NOTE: Depending on their size, the units of the **HPC-W** series are built on three different frames. The following table shows the relation between each frame and the models built on that frame.

Frame	WHT models
04	WHT2131: WH2131/051584. Order n° 65601914

The following pages show the dimensions and gravity center position for each frame.

Frame 4 - Dimensions

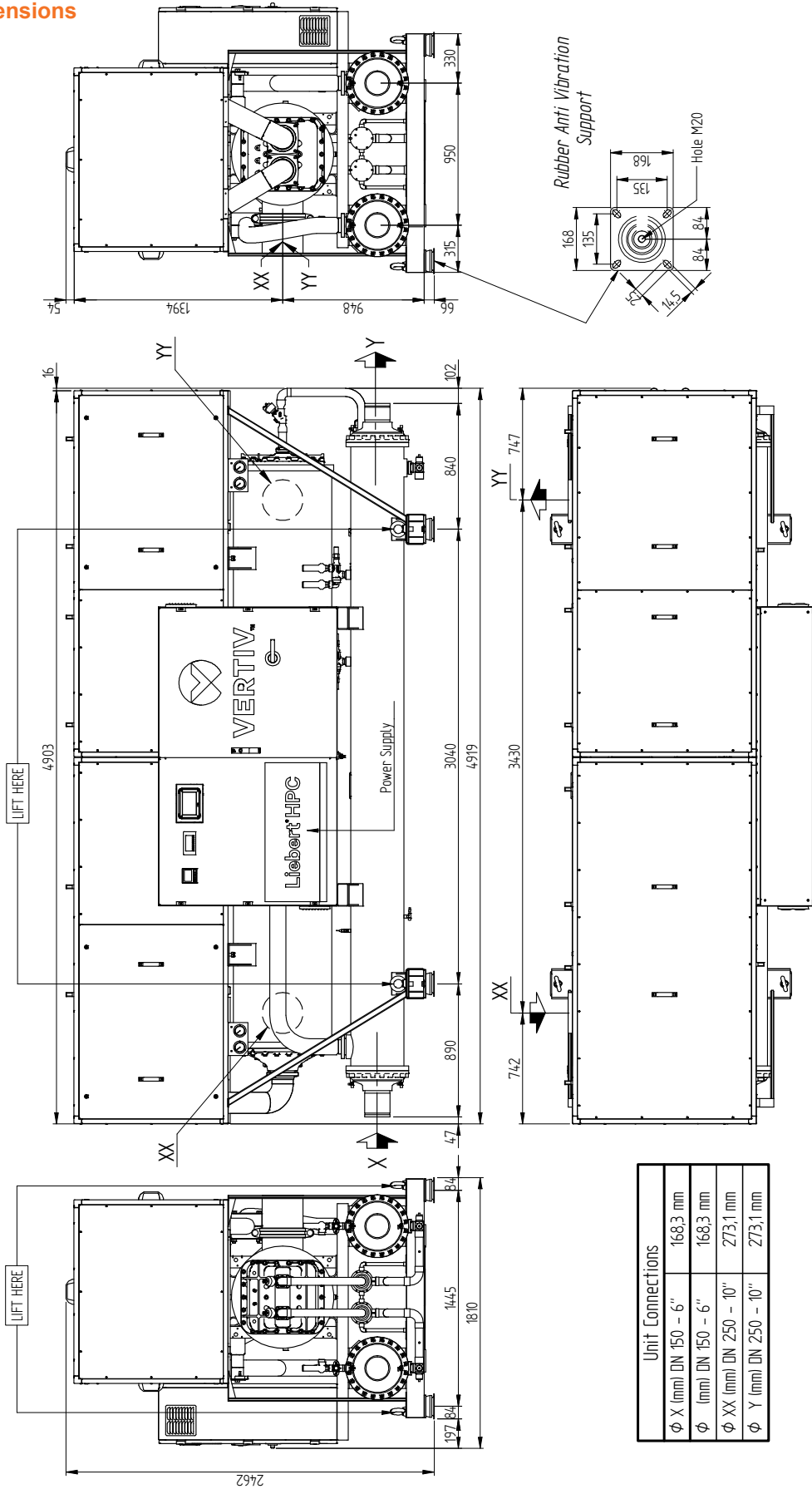

Frame 4 - Gravity center

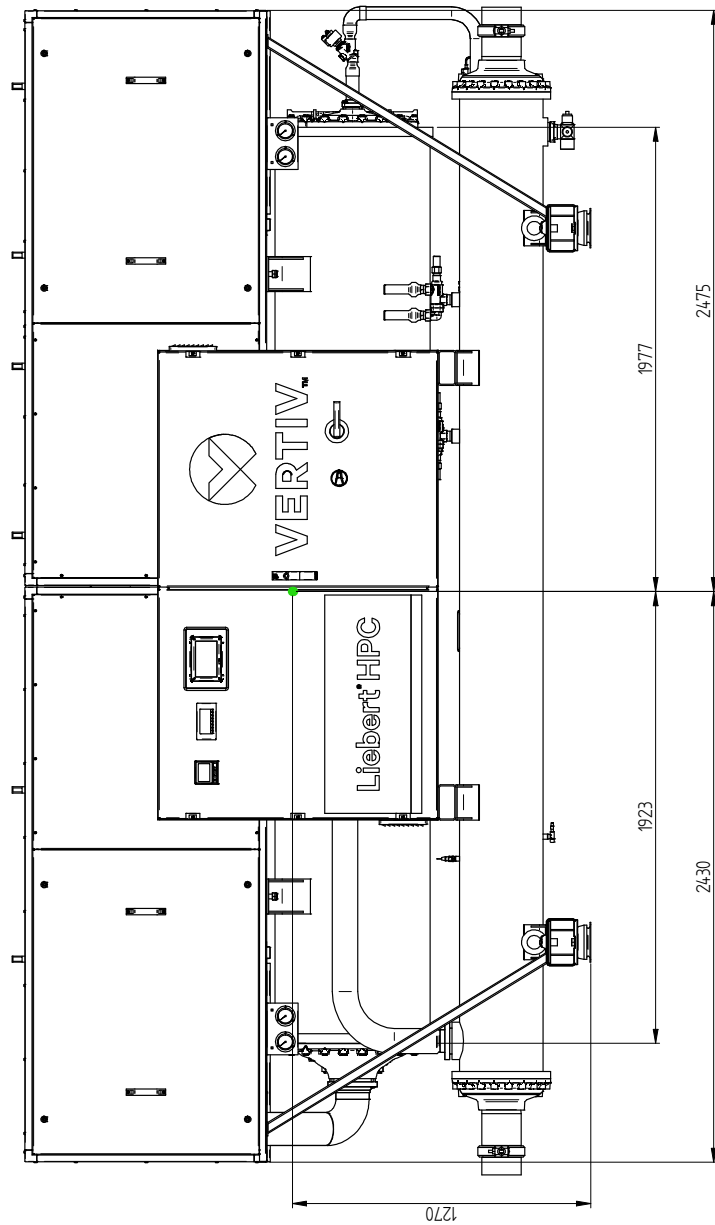
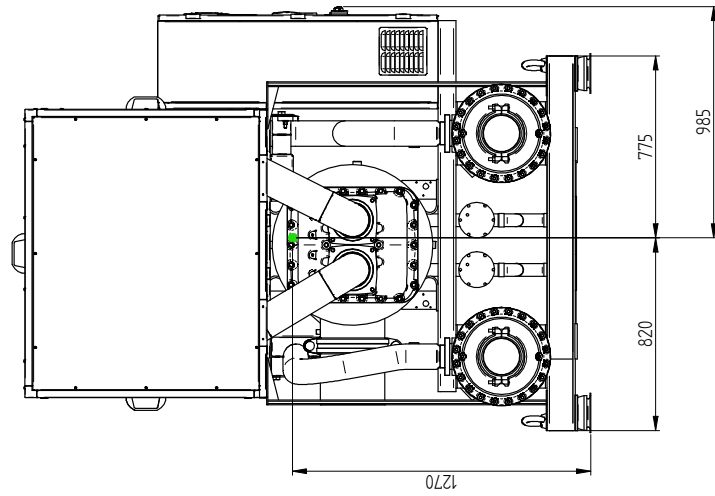

Annex II – Refrigerating Circuit

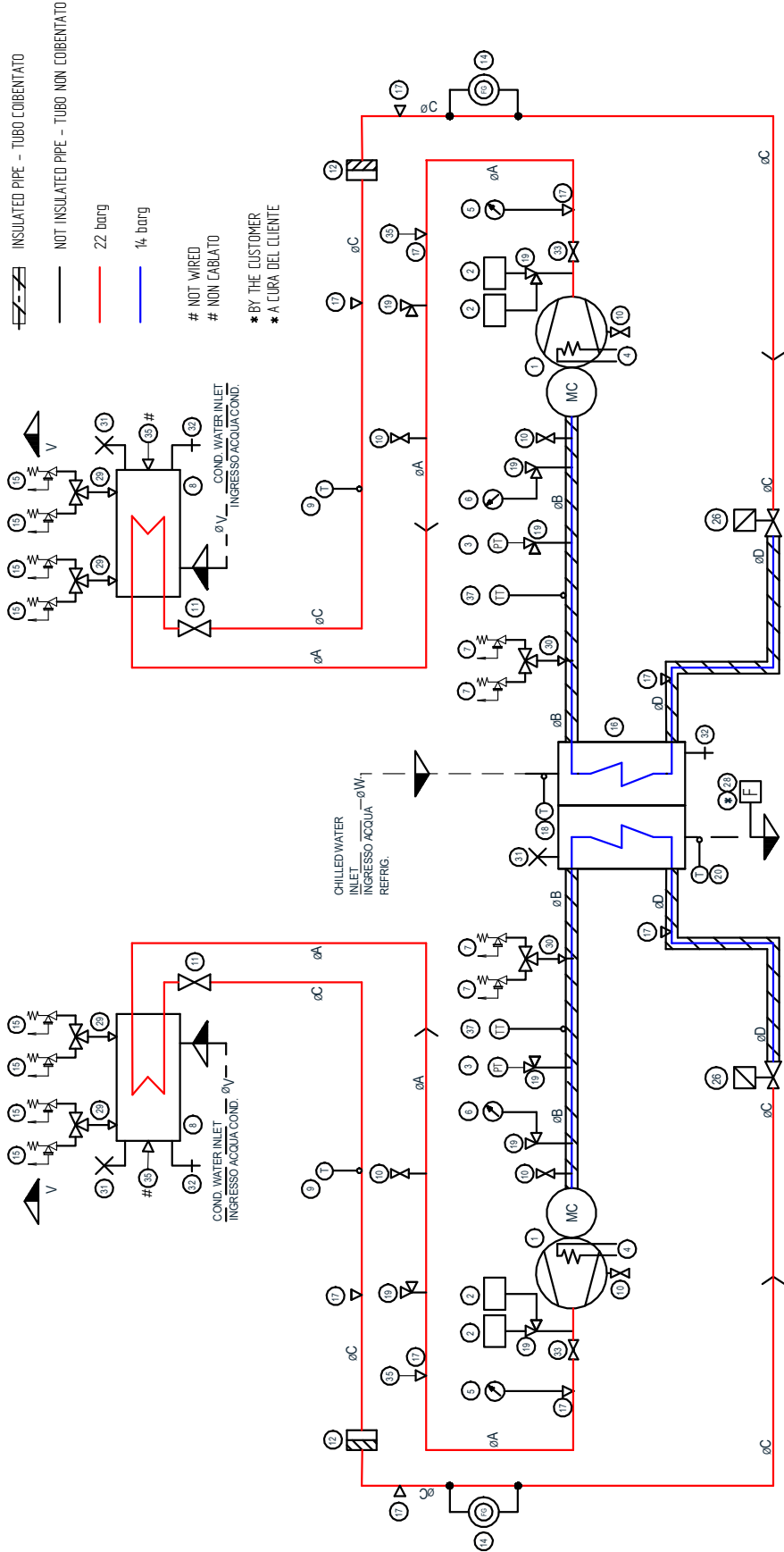

WH2131	
ØA(mm) cooper	108,0
ØB(mm) stainless steel	141,3
ØC(mm) cooper	54
ØD(mm) cooper	54
ØV(") GROOVED COUPLING	DN 150- 6"-168,27 mm
ØW(") GROOVED COUPLING	DN 250- 10"-273,05 mm

COMPONENTS AND PARTS UNDER PRESSURE	
n°	Components
2	High pressure switch
7	Safety valve (discharge line)
7	Safety valve (suction line)
8	Condenser
16	Evaporator
26	SHUT-OFF VALVE LIQUID LINE
28	ELECTRONIC EXP. VALVE (EEV)
29	FLOW SWITCH
29	COMMUTATION VALVE HP
30	COMMUTATION VALVE LP
31	MANUAL AIR VALVE
32	DISCHARGE VALVE
33	COMPRESSOR DISCHARGE VALVE
35	PRESSURE TRASDUCER H.P.
37	EEV TEMPERATURE SENSOR
11	COMPRESSOR
12	HIGH PRESSURE SWITCH
14	PRESSURE TRANSDUCER / L.P. CONTROL / EEV
15	CRANKCASE HEATER
16	HIGH PRESSURE MANOMETER (OPTIONAL)
17	LOW PRESSURE MANOMETER (OPTIONAL)
18	SAFETY VALVE LP
19	CONDENSER
20	TEMPERATURE SENSOR / SERVICE CONNECTION / SHUT-OFF VALVE

COMPONENTS AND PARTS UNDER PRESSURE

n°	Components	UE category	EN378/2 criteria	Conformity assessment module / Manufacturer	Notes
2	High pressure switch	IV	Safety: IV	B+D / Danfoss	WH2131
7	Safety valve (discharge line)	IV	Safety: IV	B+D / General Instrum.	WH2131
7	Safety valve (suction line)	IV	Safety: IV	B+D / General Instrum.	WH2131
8	Condenser	IV	PSXV	B+D / Provides	WH2131
16	Evaporator	III	PSXV	B+D / Provides	WH2131

Annex III – Safety Labels

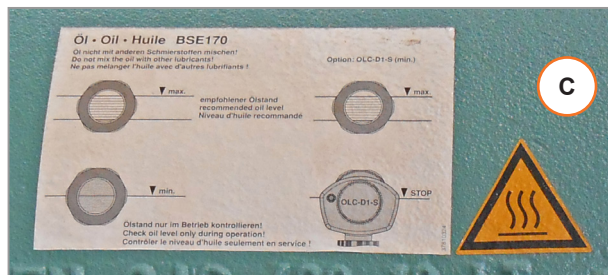
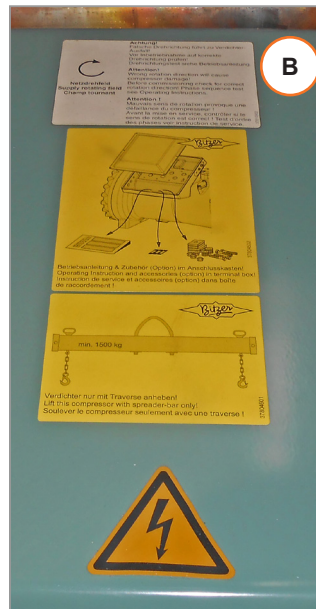
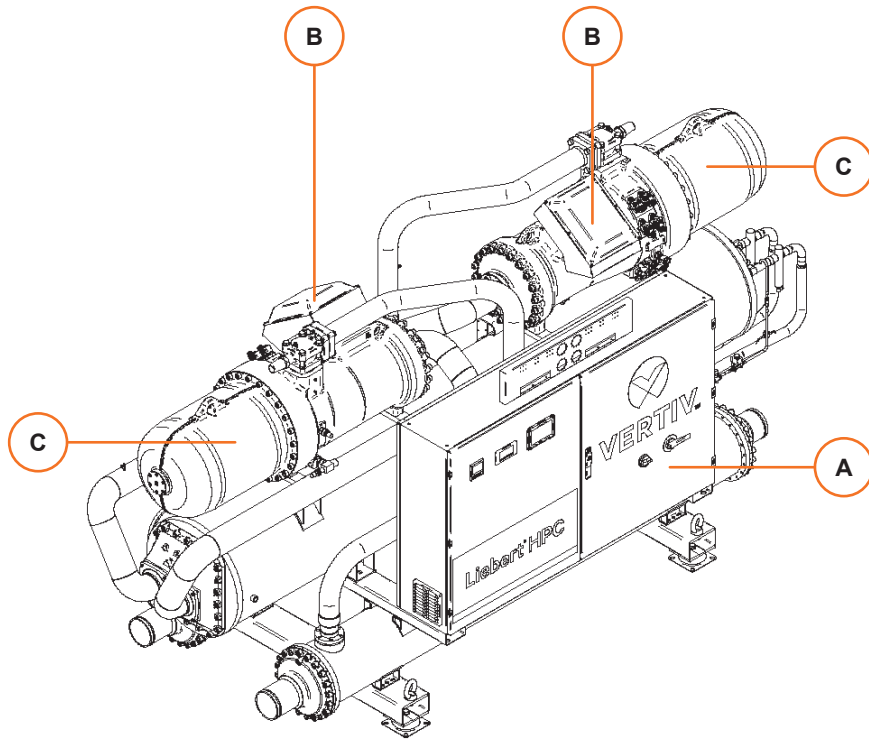



WARNING

Use this label (A) to identify removable components subject to regular maintenance that, due to their weight, require handling by **two** operators.

If it is damaged or no longer legible, apply a new label (A) on the panels highlighted in green in the image below.

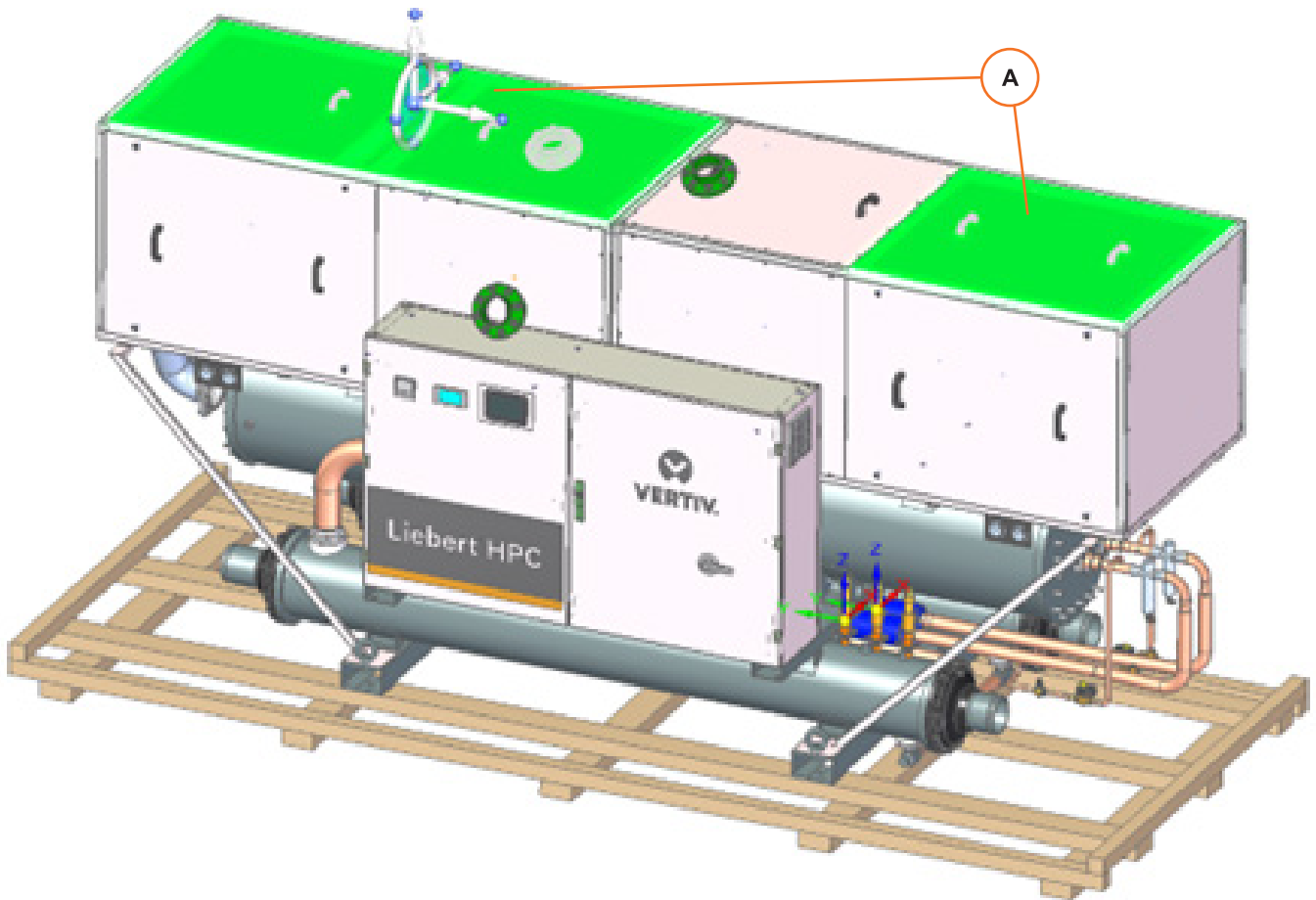



Fabbricante - Manufacturer - Hersteller - Fabricant - Fabricante Fabricante - Tillverkare - Fabrikant - Valmistaja - Produzent Fabrikant
- Κατασκευαστής - Producent
Vertiv S.r.l. - Zona Industriale Tognana
Via Leonardo da Vinci, 16/18 - 35028 Piove di Sacco - Padova (Italy)

Il Fabricante dichiara che questo prodotto è conforme alle direttive Europee:

The Manufacturer hereby declares that this product conforms to the European Union directives:

Der Hersteller erklärt hiermit, dass dieses Produkt den Anforderungen der Europäischen Richtlinien gerecht wird: Le Fabricant déclare que ce produit est conforme aux directives Européennes:

El Fabricante declara que este producto es conforme a las directivas Europeas:

O Fabricante declara que este produto está em conformidade com as directivas Europeias: Tillverkare försäkrar härmed att denna produkt överensstämmer med Europeiska Unions direktiv: De Fabrikant verklaart dat dit produkt conform de Europese richtlijnen is:

Vaimistaja vakuuttaa täten, että tämä tuote täyttää seuraavien EU-direktiivien vaatimukset: Produzent erklærer herved at dette produktet er i samsvar med EU-direktiver:

Fabrikant erklærer herved, at dette produkt opfylder kravene i EU direktiverne:

Ο Κατασκευαστής δηλώνει ότι το παρόν προϊόν είναι Αποσβεστήρας σύμφωνα με τη οδηγία της Ε.Ε.:

2006/42/EC; 2014/30/EU; 2014/35/EU; 2014/68/EU



VertivCo.com | Vertiv - EMEA, via Leonardo Da Vinci 16/18, Zona Industriale Tognana, 35028 Piove di Sacco (PD) Italy, Tel: +39 049 9719 111, Fax: +39 049 5841 257

© 2023 Vertiv Co. All rights reserved. Vertiv, the Vertiv logo and Vertiv Liebert HPC-W WH are trademarks or registered trademarks of Vertiv Co. All other names and logos referred to are trade names, trademarks or registered trademarks of their respective owners. While every precaution has been taken to ensure accuracy and completeness herein, Vertiv Co. assumes no responsibility, and disclaims all liability, for damages resulting from use of this information or for any errors or omissions. Specifications are subject to change without notice.