

Vertiv™ VR Rail Conversion Kit

Quick Installation Guide

Vertiv™ VR rail conversion kit part numbers: VRA6044, VRA6045, VRA6046, VRA6047, VRA6048, and VRA6049.



Components

Item	Description	Qty.
1	Rail conversion kit, each assembled with three rail mounting brackets (post hanging brackets (A), bracket clamps (B), and M6 x 12 pan head screws (C))	4

NOTE: These SKUs applies for 800 mm wide VR Racks.

SKU	Description
VRA6044	VR 42Ux800 21" EIA Mounting Rails
VRA6045	VR 45Ux800 21" EIA Mounting Rails
VRA6046	VR 45Ux800 23" EIA Mounting Rails
VRA6047	VR 42Ux800 23" EIA Mounting Rails
VRA6048	VR 48Ux800 21" EIA Mounting Rails
VRA6049	VR 48Ux800 23" EIA Mounting Rails

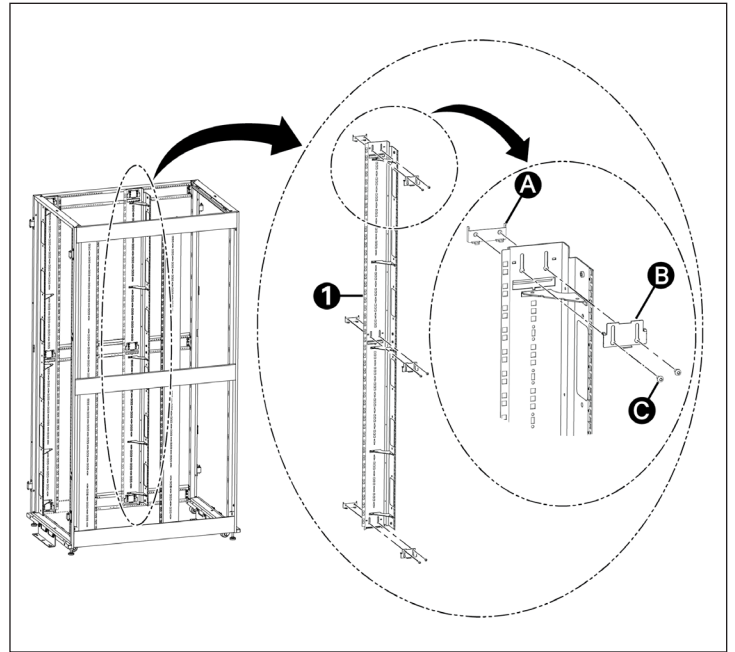

Stock Rail Removal

1. Open the rear door.
2. Remove the M6 x 12 screws (1) in the railadjustment brackets (2) that secure the stock rails to the top and bottom frame members and the center support member.
3. Slide the brackets (2) up and push them downwards to detach them from the members.

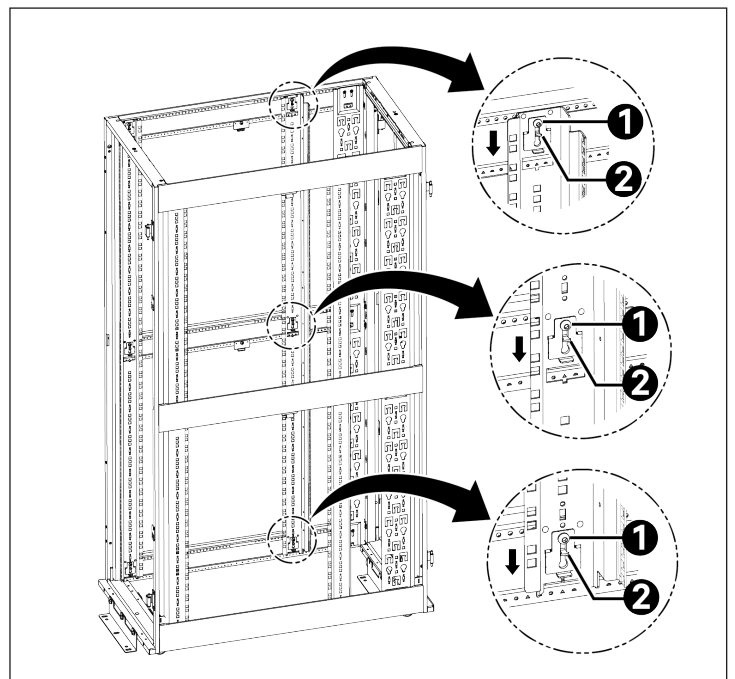

Stock Rail Removal

4. Lift the stock rail and remove it from the members.
5. Remove a total of four stock rails from the rack.

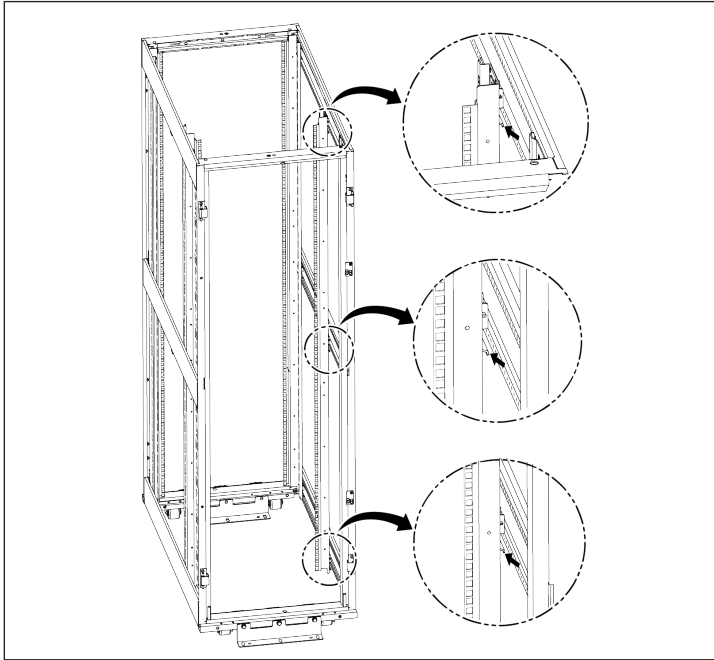

Rail Conversion Kit Installation

1. Hang the rail conversion kit onto the bottom channel of each member.

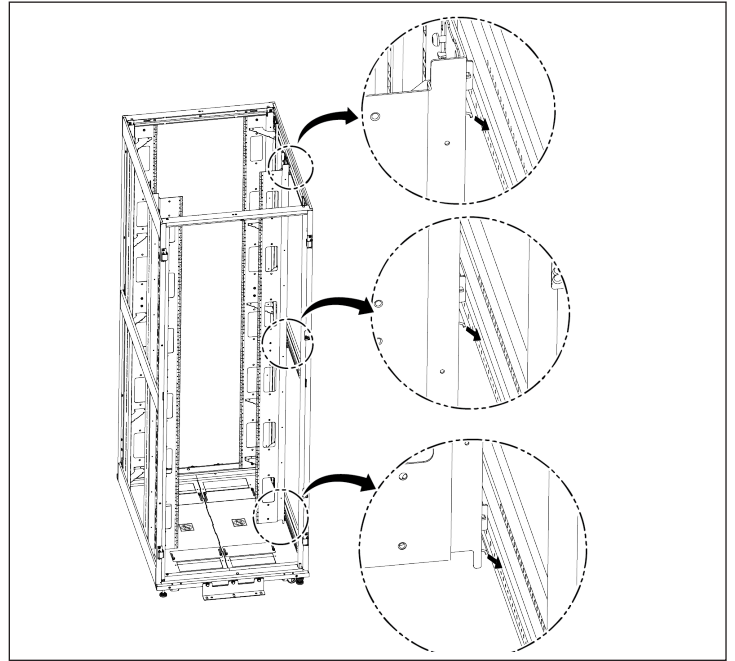

Rail Conversion Kit Installation

2. Loosen the M6 x 12 pan head screws (1) that fix the rail mounting brackets to the rails. Slide the rail mounting bracket (2) up to attach it to the front channel of each member.
3. Tighten the screws (2) to fix the rail mounting brackets.
4. Install a total of four rails (one conversion kit) on the rack.

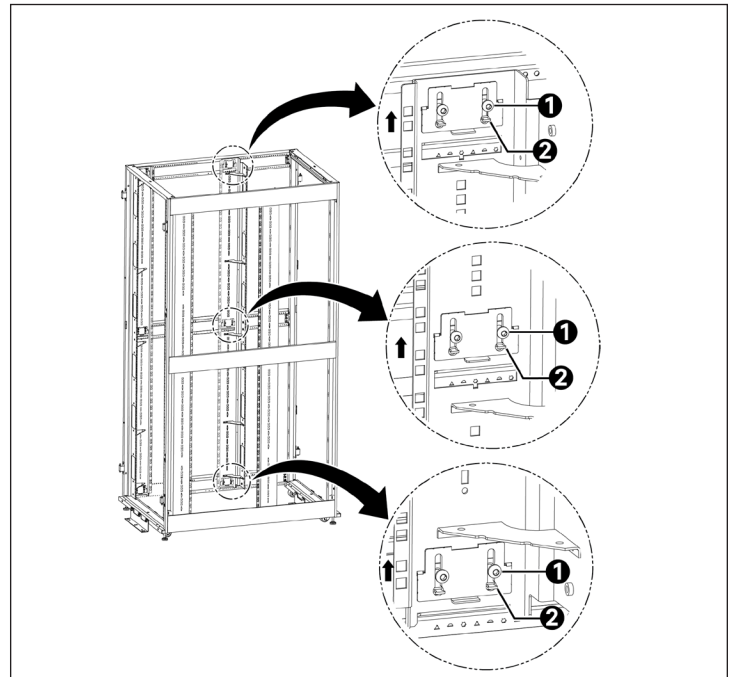

To contact Vertiv Technical Support: visit www.Vertiv.com

© 2023 Vertiv Group Corp. All rights reserved. Vertiv™ and the Vertiv logo are trademarks or registered trademarks of Vertiv Group Corp. All other names and logos referred to are trade names, trademarks or registered trademarks of their respective owners. While every precaution has been taken to ensure accuracy and completeness here, Vertiv Group Corp. assumes no responsibility, and disclaims all liability, for damages resulting from use of this information or for any errors or omissions.

