



# NetSure™ 5100 Series -48 VDC Power System

## Installation Manual

Specification Number: 582137100

Model Number: 5100

The information contained in this document is subject to change without notice and may not be suitable for all applications. While every precaution has been taken to ensure the accuracy and completeness of this document, Vertiv assumes no responsibility and disclaims all liability for damages resulting from use of this information or for any errors or omissions. Refer to other local practices or building codes as applicable for the correct methods, tools, and materials to be used in performing procedures not specifically described in this document.

The products covered by this instruction manual are manufactured and/or sold by Vertiv. This document is the property of Vertiv and contains confidential and proprietary information owned by Vertiv. Any copying, use or disclosure of it without the written permission of Vertiv is strictly prohibited.

Names of companies and products are trademarks or registered trademarks of the respective companies. Any questions regarding usage of trademark names should be directed to the original manufacturer.

### **Technical Support Site**

If you encounter any installation or operational issues with your product, check the pertinent section of this manual to see if the issue can be resolved by following outlined procedures.

Visit <https://www.vertiv.com/en-us/support/> for additional assistance.

## TABLE OF CONTENTS

<b>Admonishments Used in this Document</b> .....	<b>vi</b>
<b>Important Safety Instructions</b> .....	<b>vii</b>
Safety Admonishments Definitions.....	vii
Safety and Regulatory Statements.....	vii
Déclarations de Sécurité et de Réglementation.....	vii
<b>1 Customer Documentation Package</b> .....	<b>1</b>
<b>2 Installation Acceptance Checklist</b> .....	<b>2</b>
<b>3 Installing the System</b> .....	<b>4</b>
3.1 General Requirements.....	4
3.2 Securing the Relay Rack to the Floor.....	4
3.3 Mounting the System in a Relay Rack or an Equipment Rack.....	10
3.3.1 Mounting the Distribution Cabinet with Module Mounting Assembly(s).....	10
3.3.2 Installing a List 93, 94 Battery Tray.....	16
3.3.3 Installing Optional 4-Post Flush Mounting Kit for Data Cabinets, P/N 559801.....	27
3.4 Changing Orientation of Load Return Busbars Located in a List 20, 21, 25, or 26 Distribution Cabinet.....	31
3.5 Installing Optional Lug Adapter Busbar Kits.....	33
3.6 Installing Circuit Breakers, Fuses, and Optional Transient Voltage Surge Suppressor (TVSS) Device(s).....	34
3.7 Vertiv™ NetSure™ SPD (Surge Protection Device) Field Installation Kit P/N 60051981 and P/N 60056702 Installation Instructions.....	42
3.7.1 Kit Description.....	42
3.7.2 Kit Contents.....	42
3.7.3 Tools and Material Required.....	44
3.7.4 Installation Procedure.....	44
<b>4 Setting Jumper and Switch Options</b> .....	<b>57</b>
4.1 Circuit Cards with Jumpers and Switches in a List 20, 21, 25, 26, 27 Distribution Cabinet.....	57
4.2 Jumper Settings on the System Interface Circuit Card.....	60
4.3 Switch Settings on the IB2 (Controller Interface Board).....	61
4.4 Switch Settings on Optional EIB (Controller Extended Interface Board).....	62
4.5 Switch Settings on the SM-DU (List 60 Hybrid Connection Cabinet).....	63
4.5.1 Procedure.....	63
<b>5 Making Electrical Connections</b> .....	<b>67</b>
5.1 Important Safety Instructions.....	67
5.2 Wiring Considerations.....	67
5.3 Relay Rack / Equipment Cabinet Frame Grounding Connection.....	68
5.4 Power System Shelf Frame Grounding Requirements.....	69
5.5 Assemblies Comprising the Power System Frame Grounding Connection.....	70
5.6 Central Office Ground Connection.....	70
5.7 Rectifier Nominal 120 VAC / 208 VAC / 240 VAC Input and AC Input Equipment Grounding Connections.....	71
5.7.1 Wiring Considerations.....	71
5.7.2 To 19" or 23" Rectifier AC Input / Solar Converter DC Input Panel (List 40, 45) and 23" Rectifier AC Input Panel (List 46).....	71
5.7.3 To Individual Module Mounting Assembly(s) Equipped with Molex Connectors and Provided with Rectifier AC Input Cable Assemblies or Rectifier AC Input Line Cords.....	77

5.8	Solar Converter 140 VDC to 200 VDC / 200 VDC to 400 VDC Input Connections.....	78
5.8.1	Wiring Considerations .....	78
5.8.2	To 19" or 23" Rectifier AC Input / Solar Converter DC Input Panel (List 40, 45).....	78
5.8.3	To 23" Solar Connection Cabinet (List 61).....	81
5.8.4	To Individual Module Mounting Assembly(s) Equipped with Molex Connectors and Provided with Solar Converter DC Input Cable Assemblies.....	81
5.9	-48 VDC System Connections to an Optional List 60 Hybrid Connection Cabinet.....	84
5.10	Optional Inverter System Nominal 120 VAC Input and Equipment Grounding Connections (List 50, 51, 52, 53, 54, 55, 56, 57).....	85
5.11	Inverter System AC "Neutral" Reference Point (When DC Input Source Only Connected).....	87
5.12	Optional Inverter System Nominal 120 VAC Output Connections (List 50, 51, 52, 53, 54, 55, 56, 57).....	89
5.12.1	List 50, 52, 54, 56 (bulk output).....	89
5.12.2	List 51, 53, 55, 57 (NEMA output).....	89
5.13	External Alarm, Reference, Monitoring, and Control Connections .....	92
5.13.1	External Alarm, Reference, Monitoring, and Control Connection Locations.....	92
5.13.2	System Interface Circuit Card Connections (if required) .....	95
5.13.3	RS485 Modbus Connection (if required).....	96
5.13.4	IB2 (Controller Interface Board) Connections (if required) .....	96
5.13.5	Optional EIB (Controller Extended Interface Board) Connections (if required).....	106
5.13.6	Circuit Breaker Alarm and Shunt Monitoring Connections to an Optional List 60 Hybrid Connection Cabinet .....	112
5.13.7	Optional Customer Fuel Sensor Input.....	114
5.13.8	Connecting a Device or System to the NCU CAN Bus (if required).....	115
5.14	NCU Controller Ethernet Connection (if required).....	115
5.15	Control Bus Connections between Controller and Module Mounting Assemblies.....	118
5.16	Optional Transient Voltage Surge Suppressor (TVSS) Device Ground Connection.....	119
5.17	Load Connections.....	122
5.17.1	Load Connections to a List 20, 25 Distribution Cabinet.....	122
5.17.2	Load Connections to a List 21, 26 Distribution Cabinet .....	127
5.17.3	Load Connections to a List 27 Distribution Cabinet.....	138
5.17.4	Load Connections to an Optional GMT Fuse Block.....	141
5.17.5	Load Connections to a List KG Distribution Panel .....	142
5.18	Connections to an Optional List 60 Hybrid Connection Cabinet.....	143
5.19	Input Battery Connections.....	144
5.19.1	Input Battery Connections to List 20, 25 Distribution Cabinet.....	144
5.19.2	Input Battery Connections to List 21, 26 Distribution Cabinet.....	147
5.19.3	Input Battery Connections to List 27 Distribution Cabinet .....	151
5.20	Remote Distribution Unit (DU) Connections.....	151
5.20.1	List 27 Distribution Cabinet .....	151
5.21	Installing and Connecting Batteries in an Optional List 93 or 94 Battery Tray (if furnished).....	153
5.22	Important Safety Instructions.....	153
<b>6</b>	<b>Installing the Modules.....</b>	<b>155</b>
6.1	Installing Rectifier, Solar Converter, and Converter Modules.....	155
6.2	Installing Inverter Module in Inverter Module Mounting Assembly (If Equipped with Optional Inverter System).....	160
<b>7</b>	<b>Initially Starting, Configuring, and Checking System Operation.....</b>	<b>161</b>

7.1	Initial Startup Preparation .....	161
7.2	Initially Starting the System .....	161
7.3	NCU Controller Initialization .....	162
7.4	Verifying and Setting the NCU Controller as Required for Your Application.....	163
7.5	Checking System Status .....	168
7.6	Final Steps .....	169

## Admonishments Used in this Document



**DANGER!** Warns of a hazard the reader **will** be exposed to that will **likely** result in death or serious injury if not avoided. (ANSI, OSHA)



**WARNING!** Warns of a potential hazard the reader **may** be exposed to that **could** result in death or serious injury if not avoided. This admonition is not used for situations that pose a risk only to equipment, software, data, or service. (ANSI)



**CAUTION!** Warns of a potential hazard the reader **may** be exposed to that **could** result in minor or moderate injury if not avoided. (ANSI, OSHA) This admonition is not used for situations that pose a risk only to equipment, data, or service, even if such use appears to be permitted in some of the applicable standards. (OSHA)



**ALERT!** Alerts the reader to an action that **must be avoided** in order to protect equipment, software, data, or service. (ISO)



**ALERT!** Alerts the reader to an action that **must be performed** in order to prevent equipment damage, software corruption, data loss, or service interruption. (ISO)



**FIRE SAFETY!** Informs the reader of fire safety information, reminders, precautions, or policies, or of the locations of fire-fighting and fire-safety equipment. (ISO)



**SAFETY!** Informs the reader of general safety information, reminders, precautions, or policies not related to a particular source of hazard or to fire safety. (ISO, ANSI, OSHA)

# **Important Safety Instructions**

## **Safety Admonishments Definitions**

Definitions of the safety admonishments used in this document are listed under “Admonishments Used in this Document” on page vi.

## **Safety and Regulatory Statements**

Refer to Section 4154 (provided with your customer documentation) for Safety and Regulatory Statements.

## **Déclarations de Sécurité et de Réglementation**

Reportez-vous à la Section 4154 (fourni avec les documents de votre client) pour les déclarations de sécurité et de réglementation.

This page intentionally left blank.



# 1 Customer Documentation Package

This document (IM582137100) provides *Installation Instructions* for Vertiv™ NetSure™ -48 VDC Power System Model 5100, Spec. No. 582137100.

The complete Customer Documentation Package consists of...

## **-48 VDC Power System Installation Manual**

- Power System Installation Instructions: IM582137100

## **NCU Controller User Manual**

- NCU Controller User Instructions: UM1M830BNA

## **USB Drive with All Customer Documentation**

- Power System Installation Instructions: IM582137100
- Power System User Instructions: UM582137100
- Power System “System Application Guide”: SAG582137100
- Module Mounting Assembly Power Data Sheet: PD588705300
- NCU Controller User Instructions: UM1M830BNA
- Rectifier Instructions: UM1R482000E3
- Solar Converter Instructions: UM1S482000E3
- -48 VDC to +24 VDC Converter Instructions: UM1C48241500
- -48 VDC to -58 VDC Converter Instructions: UM1C48582000P3
- Inverter Instructions: UM1I1201000
- Engineering Drawings
- Also provided on the USB drive is a controller configuration drawing and the controller configuration files loaded into the controller as shipped.

## 2 Installation Acceptance Checklist

Provided in this section is an Installation Acceptance Checklist. This checklist helps ensure proper installation and initial operation of the system. As the procedures presented in this document are completed, check the appropriate box on this list. If the procedure is not required to be performed for your installation site, also check the box in this list to indicate that the procedure was read. When installation is done, ensure that each block in this list has been checked. Some of these procedures may have been factory performed for you.



**NOTE!** The system is not powered up until the end of this checklist.



**NOTE!** Some of these procedures may have been performed at the factory for you.

### **Installing the System**

- Relay Rack Secured to Floor (if required)
- Distribution Cabinet with Module Mounting Assembly(s) Secured to Relay Rack or Equipment Rack
- Optional Battery Tray Installed
- Optional Battery Tray Battery Disconnect Circuit Breaker Installed
- Optional P/N 559801 4-Post Flush Mounting Kit for Data Cabinets Installed (if required)
- Optional P/N 560075 Field Expansion Module Mounting Assembly Spacer Kit Installed (if required)
- Optional P/N 559802 Flush Mounting Kit for Relay Rack, NEBS Zone 2 Installed (if required)
- Load Return Busbar Orientation Changed (if required)
- Optional Lug Adapter Busbar Kits Installed
- Circuit Breakers and/or Fuses Installed
- Optional Transient Voltage Surge Suppressor (TVSS) Device(s) Installed

### **Setting Jumper and Switch Options**

- Jumper on System Interface Circuit Card Set
- Factory Switch Setting on IB2 (Controller Interface Board) Verified
- Factory Switch Setting on Optional EIB (Controller Extended Interface Board) Verified
- Factory Switch Settings on SM-DU Circuit Card (located in Optional List 60 Hybrid Connection Cabinet) Verified

### **Making Electrical Connections**

- Relay Rack / Cabinet Frame Grounding Connection Made
- Assemblies Comprising the Power System Frame Grounding Connection Made
- Central Office Ground Connection Made
- Rectifier AC Input and AC Input Equipment Grounding Connections Made
- Solar Converter DC Input Connections Made (if required)

- 48 VDC System Connections to an Optional List 60 Hybrid Connection Cabinet Made (if required)
- Optional Inverter System AC Input and AC Input Equipment Grounding Connections (List 50, 51, 52, 53, 54, 55, 56, 57) Made
- AC "Neutral" Reference Point (If Equipped with Optional Inverter System) Made (if required)
- Optional Inverter System AC Output Connections (List 50, 51, 52, 53, 54, 55, 56, 57) Made
- External Alarm, Reference, Monitoring, and Control Connections to System Interface Circuit Card Made
- External Alarm, Reference, Monitoring, and Control Connections to IB2 (Controller Interface Board) Made
- External Alarm, Reference, Monitoring, and Control Connections to Optional EIB (Controller Extended Interface Board) Made
- Fuel Sensor Connection Made (if required)
- Circuit Breaker Alarm and Shunt Monitoring Connections to SM-DU Circuit Card (located in Optional List 60 Hybrid Connection Cabinet) Made
- External Device (such as SM-Temp Module) Connection to NCU Controller CAN Bus Made (if required)
- NCU Controller Ethernet Port Connection Made
- NCU Controller Second Ethernet Port Connection Made (if required)
- Factory NCU Control Bus Connections between NCU Controller and Module Mounting Assembly(s) Verified
- Optional Transient Voltage Surge Suppressor (TVSS) Device(s) Ground Connection Made
- Load Connections to Distribution Cabinet Made
- Load Connections to GMT Fuse Block Made (if required)
- Connections to Optional List 60 Hybrid Connection Cabinet Made
- External Battery Connections Made
- Internal Batteries Installed and Connected in an Optional Battery Tray

### **Installing the Modules**

- Rectifier, Solar Converter, Converter Modules, and Inverter Modules (if equipped with Optional Inverter System) Installed

### **Initially Starting the System**

- System Started, Configured, and Checked

## 3 Installing the System

### 3.1 General Requirements

- This product is intended only for installation in a restricted access location on or above a non-combustible surface.
- This product must be located in a controlled environment with access to crafts persons only.
- This product is intended for installation in network telecommunication facilities (CO, vault, hut, or other environmentally controlled electronic equipment enclosure).
- This product is intended for connection to the common bonding network in a network telecommunication facility (CO, vault, hut, or other environmentally controlled electronic equipment enclosure).
- The DC return connection to this system can remain isolated from system frame and chassis (DC-I).
- This system is suitable for installation as part of the Common Bonding Network (CBN).
- The installer should be familiar with the installation requirements and techniques to be used in securing the relay rack to the floor.
- The installer should be familiar with the installation requirements and techniques to be used in securing the distribution cabinet with module mounting assembly(s) to a relay rack or equipment rack.
- The system must be mounted in an environment that does not exceed the rated operating ambient temperature range found in SAG582137100.
- Clearance requirements are:
  - a) Recommended minimum aisle space clearance for the front of each bay is 2' 6".
  - b) Recommended minimum aisle space clearance for the rear of each bay is 2' 0" for any of the following conditions:
    1. Addition of a module mounting assembly in the field.
    2. Making input connections to a field installed module mounting assembly.
    3. Adding battery tray(s) in the field.

For all other conditions, required minimum spacing from the rear of the system to a wall or other solid structure must not be less than four (4) inches and from the front of the system not less than two (2) inches. This will assure proper airflow through the rectifier, solar converter, and converter modules.



**NOTE!** Minimum spacing specified for ventilation may not permit replacement of certain components such as busbars or module mounting assemblies.

- Front door and top / rear covers must be removed in cabinet applications above +40 °C (+104 °F). See SAG582137100 for temperature ratings.

### 3.2 Securing the Relay Rack to the Floor

All equipment ordered is factory mounted to the relay rack or shipping rails specified when ordered.

Secure the relay rack to the floor per site requirements. Refer to “General Requirements” on page 4.

#### **Ventilation Requirements**

Refer to “General Requirements” on page 4.

## Relay Rack Floor Mounting Dimensions

Refer to Figure 3.1 and Figure 3.2 for relay rack floor mounting dimensions.

### Optional Relay Rack Isolation Kit

Refer to Figure 3.3 when using the Optional Relay Rack Isolation Kit.

**Figure 3.1 Relay Rack Floor Mounting Dimensions - 23" (cont'd on next page)**

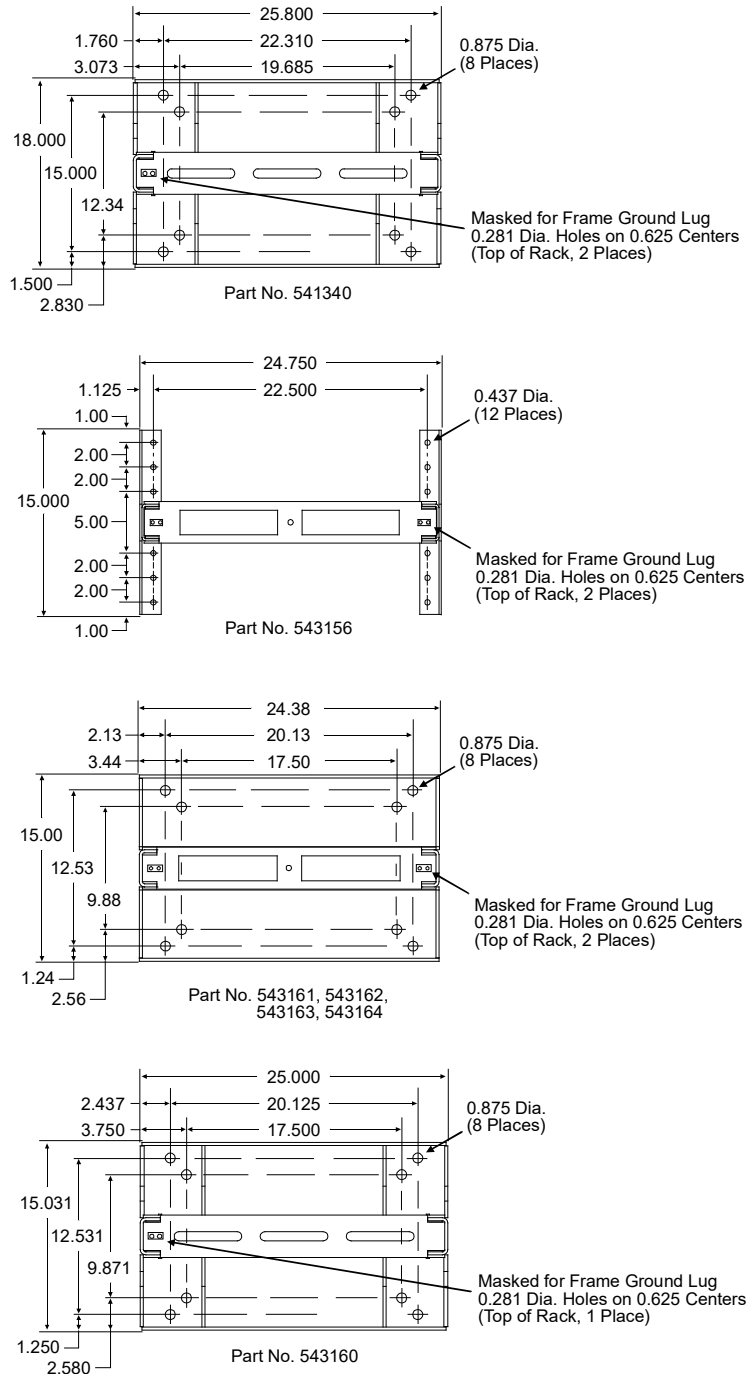
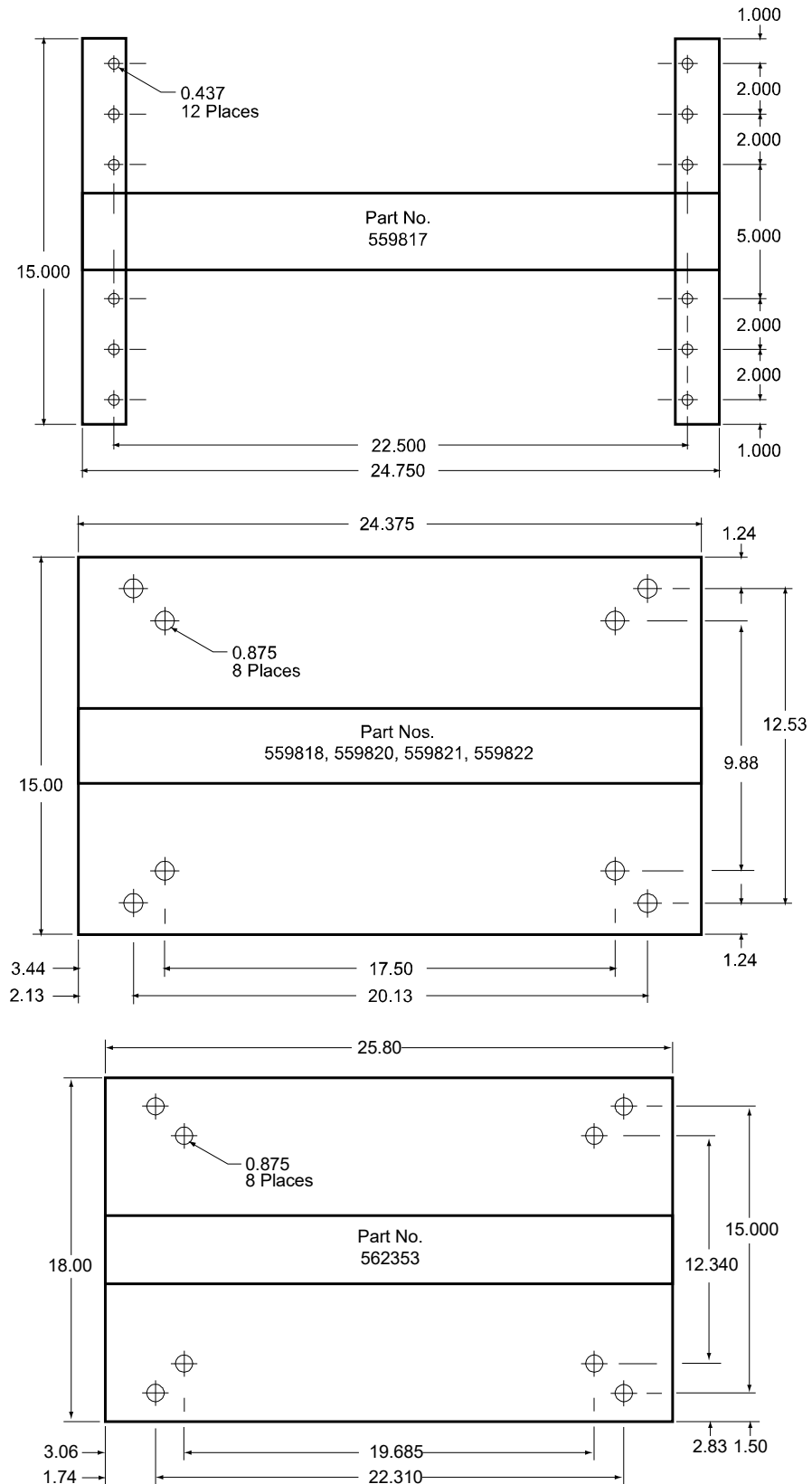
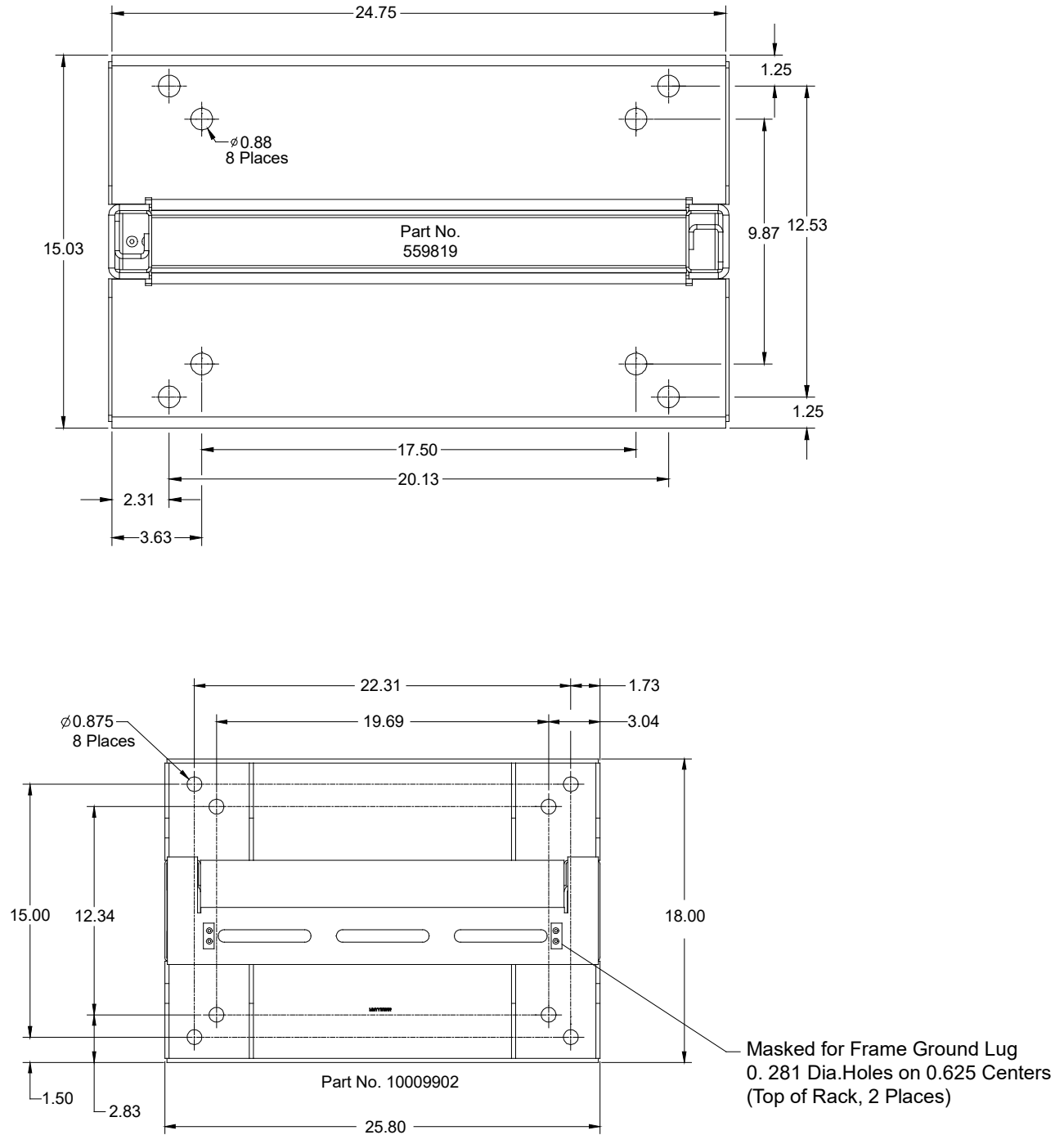


Figure 3.1 Relay Rack Floor Mounting Dimensions - 23" (cont'd from previous page, cont'd on next page)



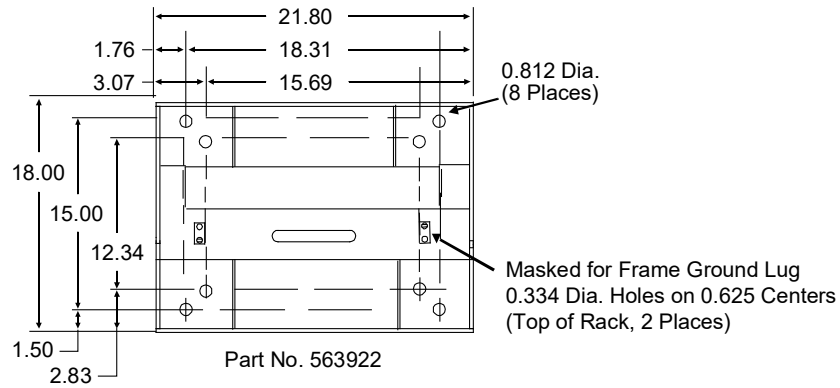
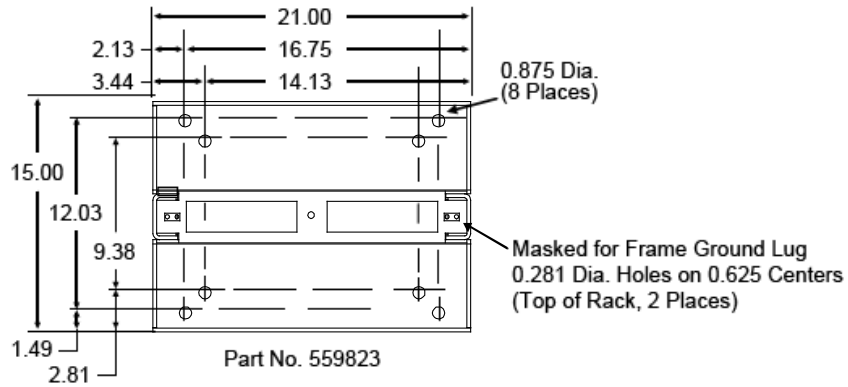
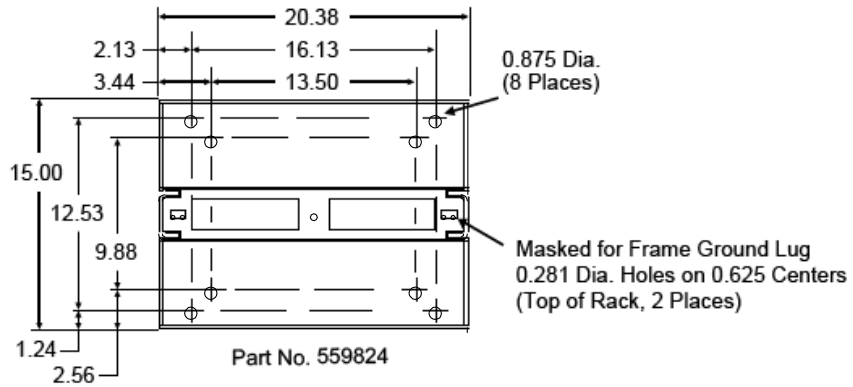
Notes:  
1. All dimensions are in inches.

Figure 3.1 Relay Rack Floor Mounting Dimensions - 23" (cont'd from previous page)



Notes:  
 1. All dimensions are in inches.

**Figure 3.2 Relay Rack Floor Mounting Dimensions - 19"**

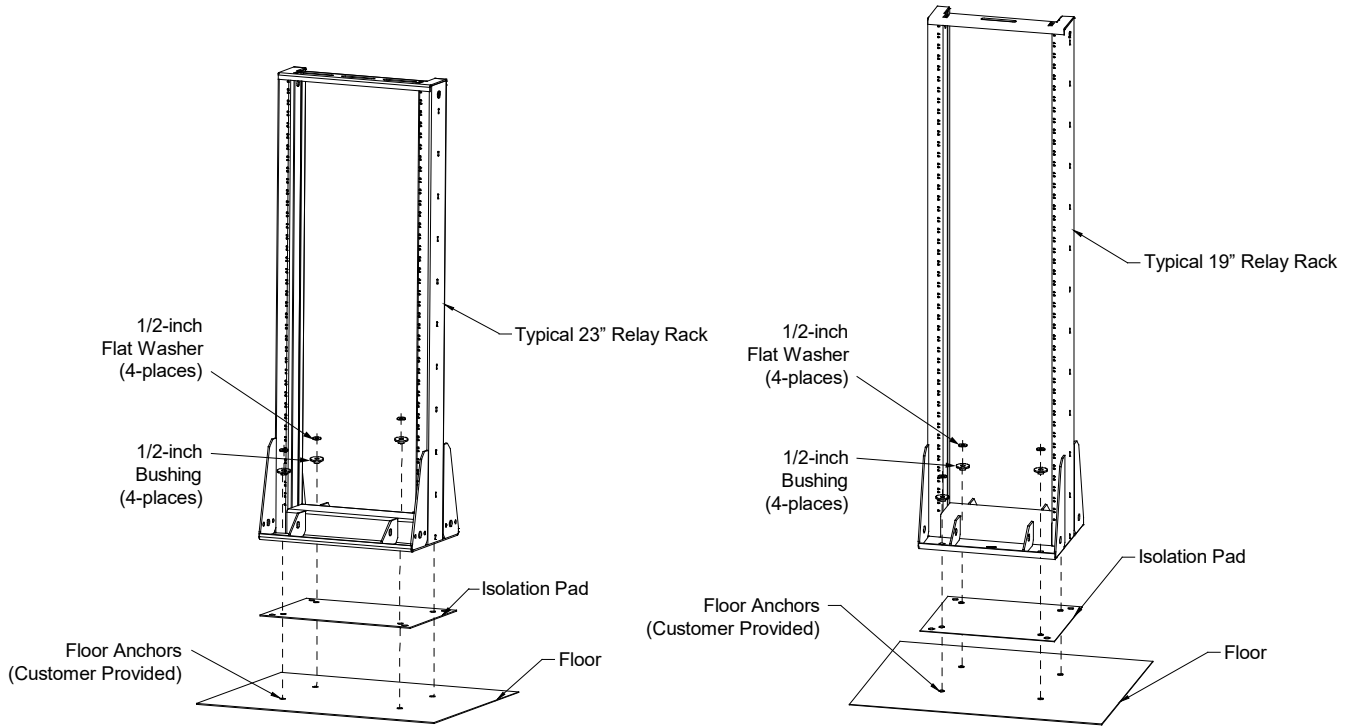


**Notes:**

1. All dimensions are in inches.



Figure 3.3 Optional Relay Rack Isolation Kit Mounting



### 3.3 Mounting the System in a Relay Rack or an Equipment Rack



**NOTE!** If the power system was ordered in a relay rack, these procedures have been performed at the factory.

This power system is designed to mount in a standard 19" or 23" (depending on configuration ordered) relay rack or equipment rack having 1" or 1-3/4" multiple drillings. Refer to System Application Guide SAG582137100 for overall dimensions and a list of available relay racks.



**NOTE!** Refer to "General Requirements" on page 4 for mounting restrictions and ventilation requirements.



**NOTE!** A 4-post mounting kit for a data cabinet is available. See SAG582137100.



**NOTE!** A special mounting bracket kit (P/N 564300) is available. See SAG582137100. Mounting instructions using this kit is provided in this section.



**NOTE!** A 19" to 23" wide relay rack mounting bracket kit (P/N 553630) is available. See SAG582137100. Mounting instructions using this kit is provided in this section.

#### 3.3.1 Mounting the Distribution Cabinet with Module Mounting Assembly(s)



**NOTE!** The distribution cabinet is factory connected to the module mounting assembly(s). The distribution cabinet with module mounting assembly(s) is mounted as a complete assembly.

The distribution cabinet with module mounting assembly(s) must be the top-most component in the rack. Perform the following steps to mount the distribution cabinet with module mounting assembly(s).



**DANGER!** If the system is mounted in a relay rack, the relay rack must be securely anchored to the floor before the distribution cabinet with module mounting assembly(s) is installed.



**DANGER!** The distribution cabinet with module mounting assembly(s) is heavy. Use a hoist, battery lift, or other appropriate lifting device to raise and support the assembly during the installation. Take appropriate precautions to avoid injury.

#### **Procedure**

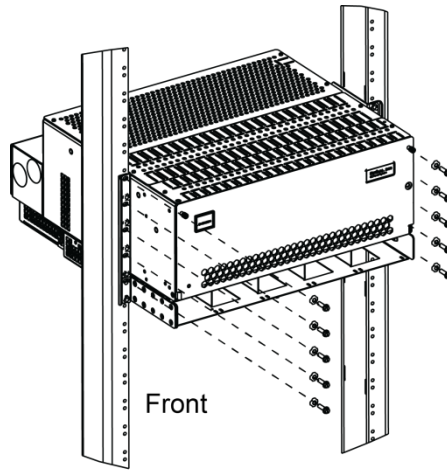
1. Remove the distribution cabinet with module mounting assembly(s) from its shipping rails. Position the assembly in the relay rack or equipment rack.



**NOTE!** In the next steps, install (orient) the ground washers so the teeth dig into the mounting angles for a secure ground connection.

2. Mount the distribution cabinet to the rack using hardware as shown in Figure 3.4 or Figure 3.5. Refer to Figure 3.4 or Figure 3.5 for recommended torque.
3. Mount the module mounting assembly(s) to the rack using hardware as shown in Figure 3.4 or Figure 3.5. Refer to Figure 3.4 or Figure 3.5 for recommended torque.

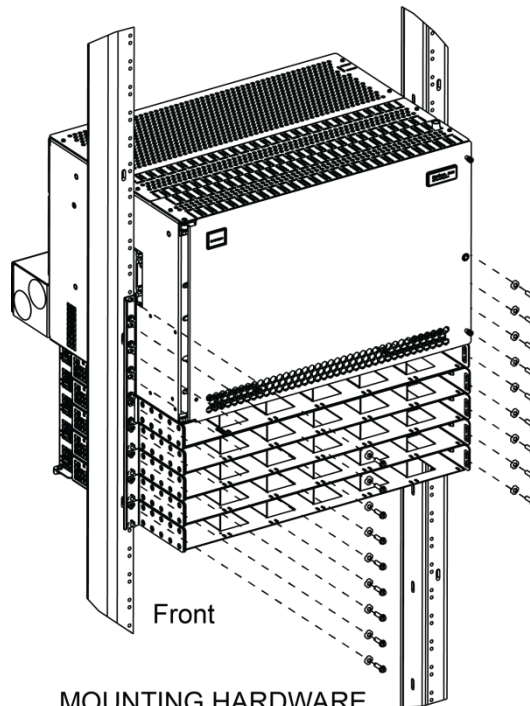
**Figure 3.4 Mounting a System with a 1-Row Distribution Cabinet (List 20, 25, 27)**



**MOUNTING HARDWARE**

12-24 x 3/4" Thread Forming  
Hex Head Screw  
No. 10/12 Ground Washer  
Torque: 65 in-lbs.

**Figure 3.5 Mounting a System with a 2-Row Distribution Cabinet (List 21, 26)**



**MOUNTING HARDWARE**

12-24 x 3/4" Thread Forming  
Hex Head Screw  
No. 10/12 Ground Washer  
Torque: 65 in-lbs.

## **Mounting the Distribution Cabinet with Module Mounting Assembly Using Special Mounting Bracket Kit P/N 564300**

The special mounting bracket kit P/N 564300 is used to mount a system configuration consisting of a single row distribution panel and a single module mounting assembly in a 1" center to center mounting hole relay rack with a maximum of 7-3/4" from the front side of the rack to the back of the system.



**NOTE!** *The distribution cabinet is factory connected to the module mounting assembly. The distribution cabinet with module mounting assembly is mounted as a complete assembly.*

Perform the following steps to mount the distribution cabinet with module mounting assembly.



**DANGER!** If the system is mounted in a relay rack, the relay rack must be securely anchored to the floor before the distribution cabinet with module mounting assembly is installed.



**DANGER!** The distribution cabinet with module mounting assembly is heavy. Use a hoist, battery lift, or other appropriate lifting device to raise and support the assembly during the installation. Take appropriate precautions to avoid injury.

### **Procedure**



**NOTE!** *In the next step, install (orient) the kit supplied ground washers so the teeth dig into the special mounting brackets for a secure ground connection.*

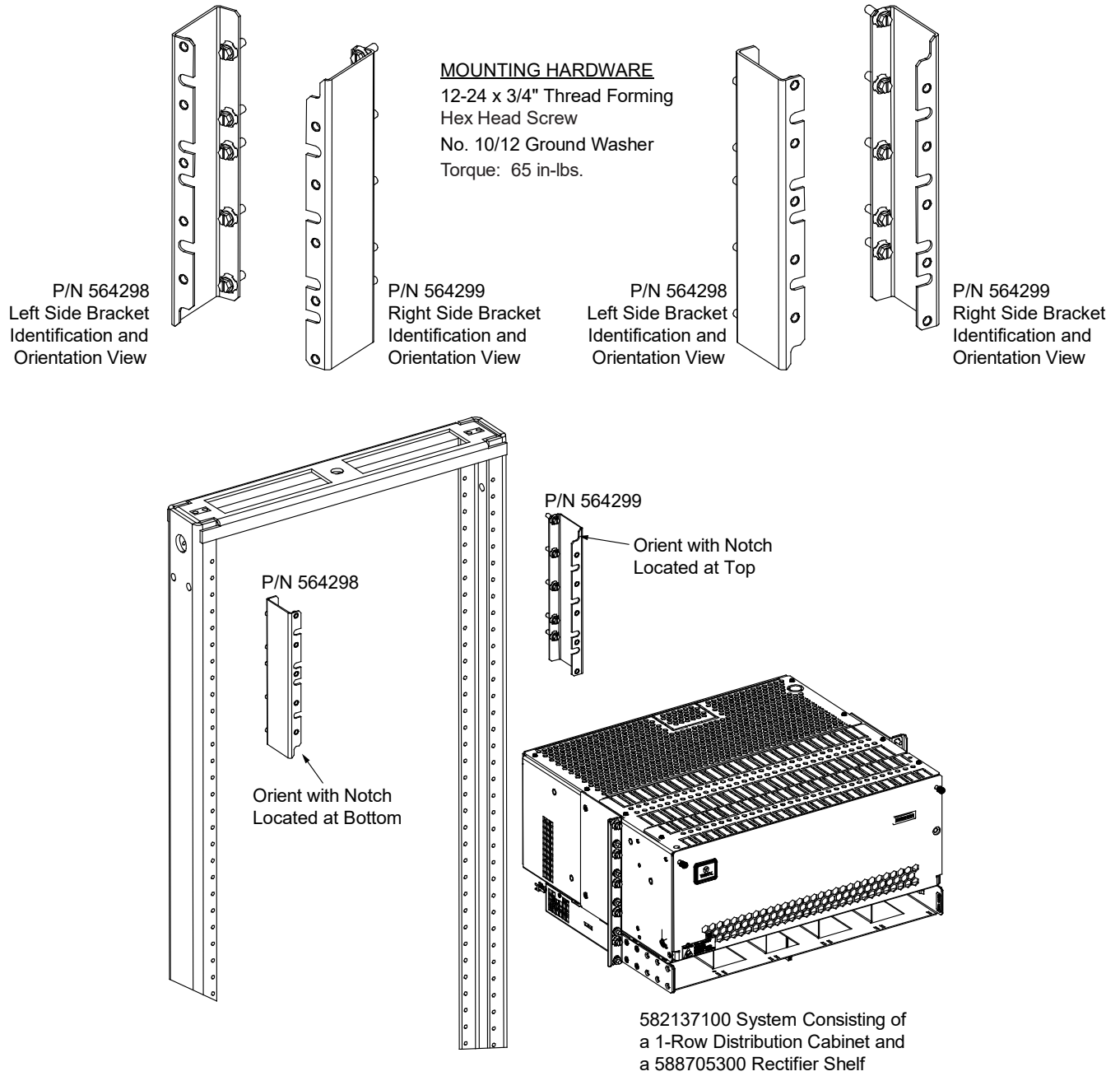
1. Refer to Figure 3.6 and attach the left and right kit supplied special mounting brackets to the rack. Refer to Figure 3.6 to identify the left and right special mounting brackets and to orient the brackets correctly. Refer to Figure 3.6 for recommended torque.
2. Remove the distribution cabinet with module mounting assembly from its shipping rails or box. Mount the assembly onto the special mounting brackets attached to the rack in the previous step.



**NOTE!** *In the next step, install (orient) the ground washers so the teeth dig into the mounting angles for a secure ground connection.*

3. Mount the distribution cabinet with module mounting assembly to the rack using hardware as shown in Figure 3.4. Refer to Figure 3.4 for recommended torque.

**Figure 3.6 Mounting a System with a 1-Row Distribution Cabinet and a Single Module Mounting Assembly using Kit P/N 564300**



## **Mounting the Distribution Cabinet with Module Mounting Assembly Using 19" to 23" Wide Relay Rack Mounting Bracket Kit P/N 553630**

The 19" to 23" wide relay rack mounting bracket kit (P/N 553630) allows mounting of a 6RU system consisting of a 19" wide 1-row distribution cabinet (582137100 List 20) and two (2) 19" wide module mounting assemblies (588705300) in a 23" wide relay rack.



**NOTE!** *The distribution cabinet is factory connected to the module mounting assembly. The distribution cabinet with module mounting assembly is mounted as a complete assembly.*

Perform the following steps to mount the distribution cabinet with module mounting assembly.



**DANGER!** If the system is mounted in a relay rack, the relay rack must be securely anchored to the floor before the distribution cabinet with module mounting assembly is installed.



**DANGER!** The distribution cabinet with module mounting assembly is heavy. Use a hoist, battery lift, or other appropriate lifting device to raise and support the assembly during the installation. Take appropriate precautions to avoid injury.

### **Procedure**



**NOTE!** *In the next step, install (orient) the kit supplied ground washers so the teeth dig into the mounting brackets for a secure ground connection.*

1. Remove the distribution cabinet with module mounting assembly from its shipping rails or box. Attach the kit supplied mounting brackets to the 6RU power system using hardware as shown in Figure 3.7. Refer to Figure 3.7 for recommended torque.

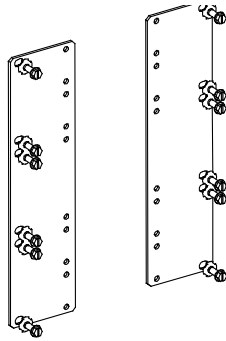


**NOTE!** *In the next step, install (orient) the kit supplied ground washers so the teeth dig into the mounting brackets for a secure ground connection.*

2. Mount the 6RU power system with the mounting bracket kit installed to the 23" relay rack using hardware as shown in Figure 3.7. Refer to Figure 3.7 for recommended torque.

**Figure 3.7 Mounting the Distribution Cabinet with Module Mounting Assembly Using 19" to 23" Wide Relay Rack Mounting Bracket Kit P/N 553630**

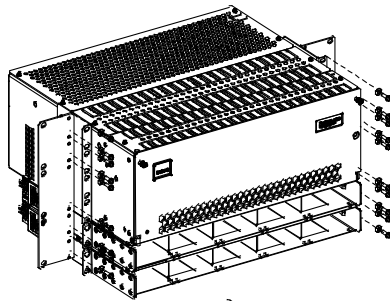
P/N 553630  
19" to 23" Wide  
Relay Rack Mounting  
Bracket Kit



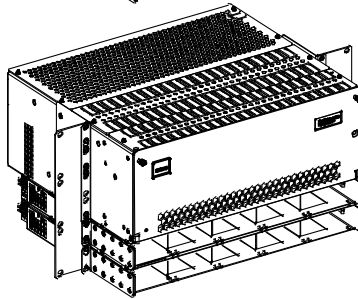
Install P/N 553630  
Mounting Bracket Kit  
to 6RU Power System

MOUNTING HARDWARE

12-24 x 3/4" Thread  
Forming Hex Head Screw  
No. 10/12 Ground Washer  
Torque: 65 in-lbs.



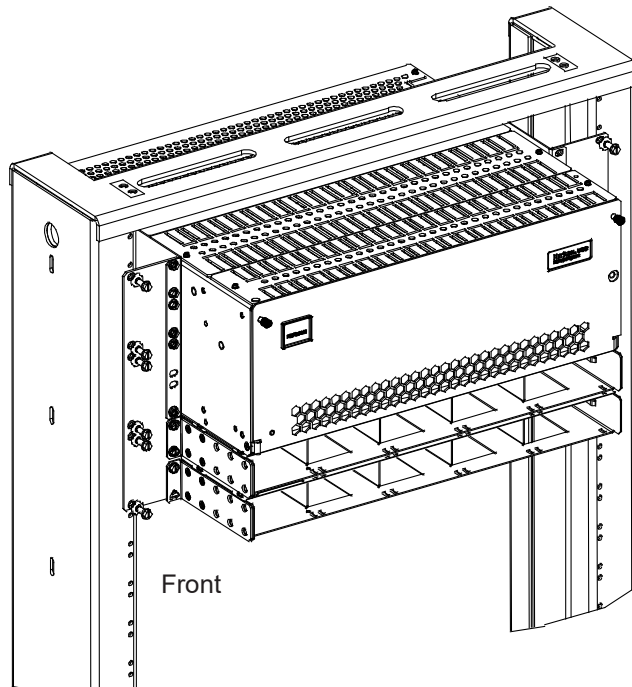
Bracket Kit  
Installed View



Install 6RU Power System  
(with bracket kit) to  
23" Wide Relay Rack

MOUNTING HARDWARE

12-24 x 3/4" Thread  
Forming Hex Head Screw  
No. 10/12 Ground Washer  
Torque: 65 in-lbs.



### 3.3.2 Installing a List 93, 94 Battery Tray

Perform the following procedures to install a battery tray.



**DANGER!** The relay rack must be securely anchored to the floor before a battery tray is installed.

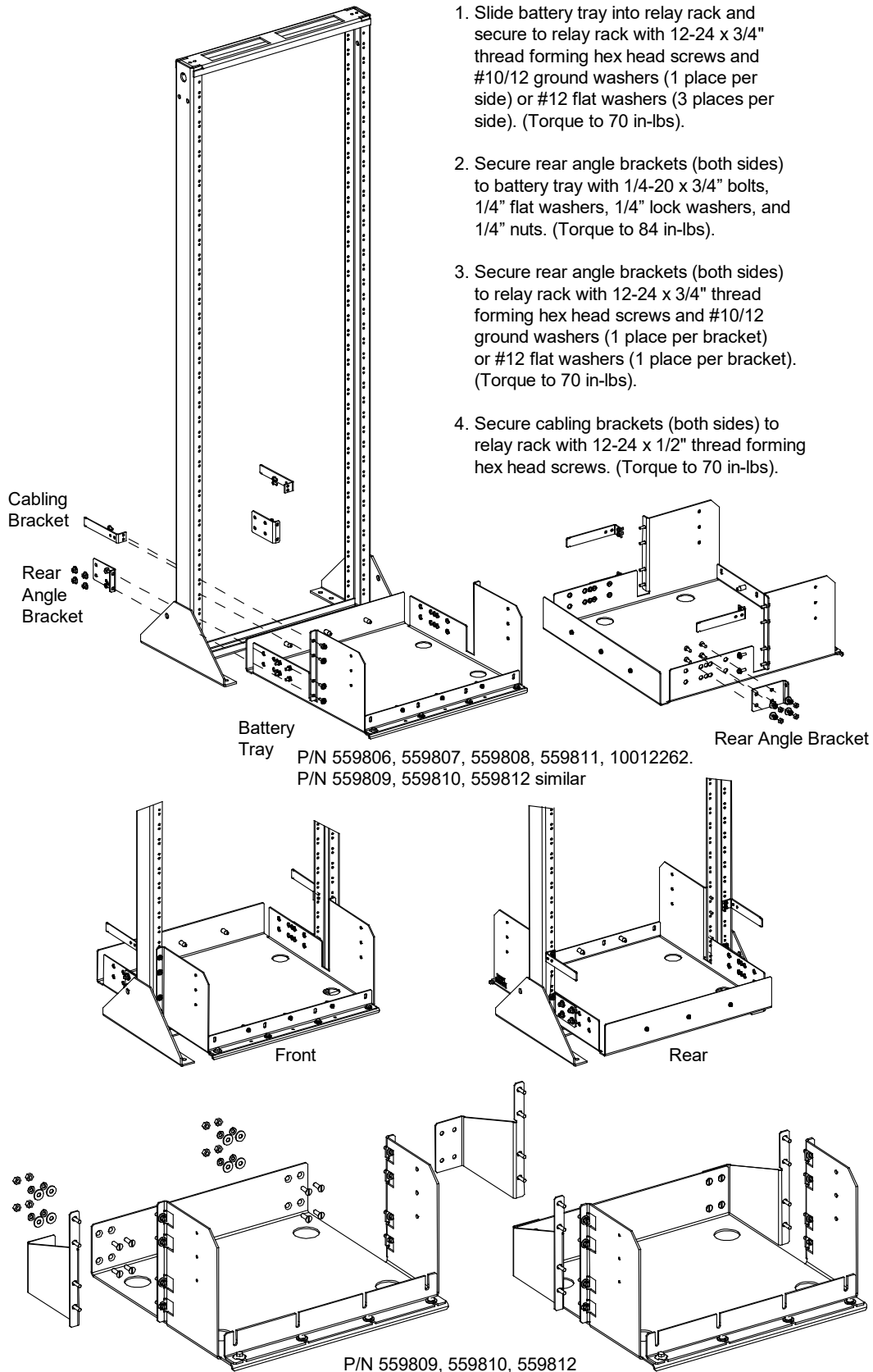
#### **Battery Tray Installation**

##### **Procedure**

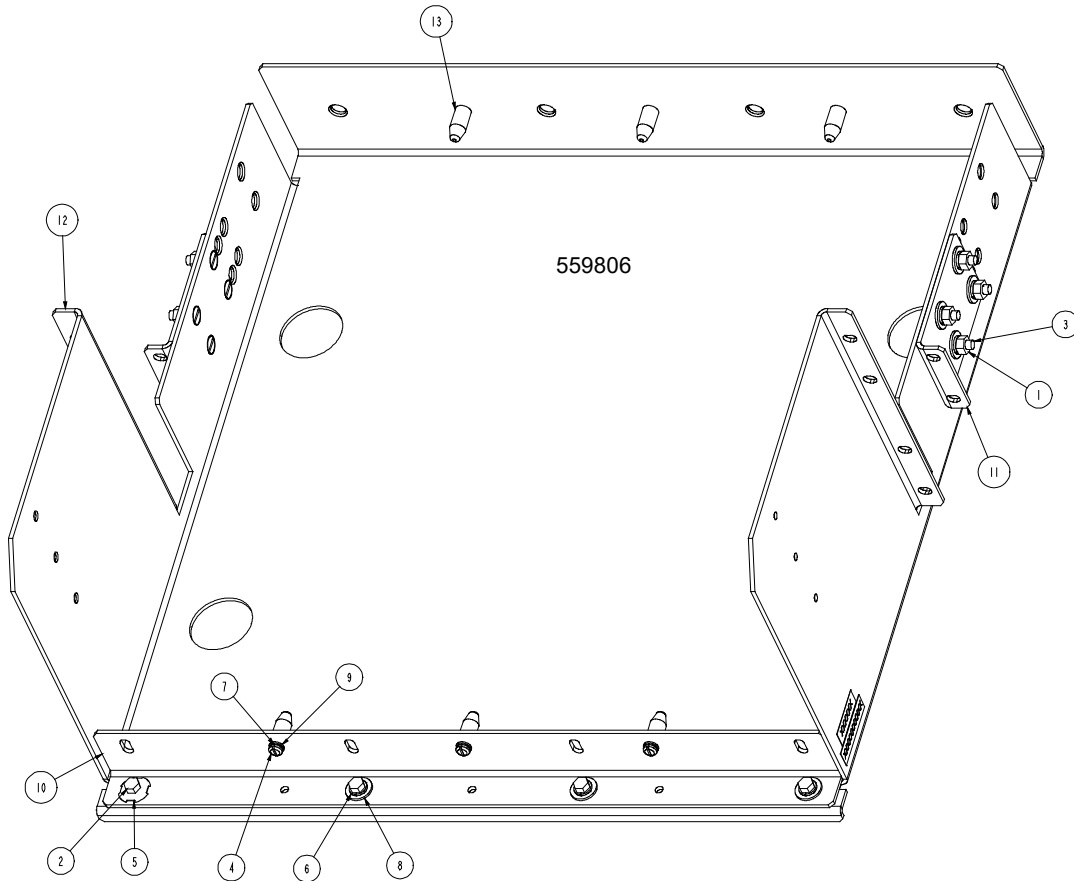
1. To install a battery tray, perform the procedure detailed in Figure 3.8. See also Figure 3.9, Figure 3.10, Figure 3.11, Figure 3.12, Figure 3.13, Figure 3.14, and Figure 3.15.



Figure 3.8 Installing a List 93, 94 Battery Tray

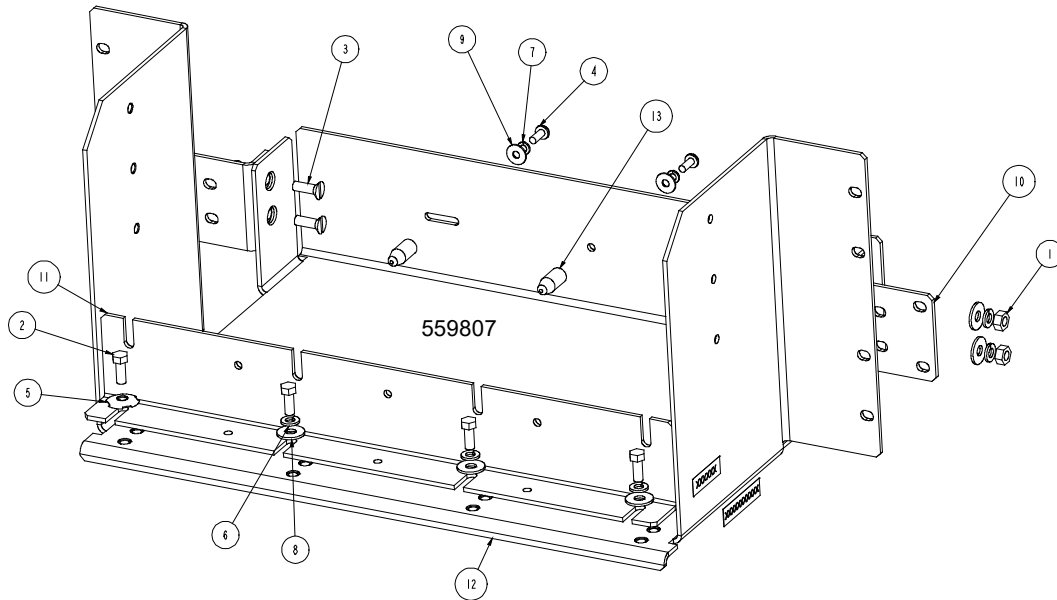


**Figure 3.9 559806 Battery Tray**



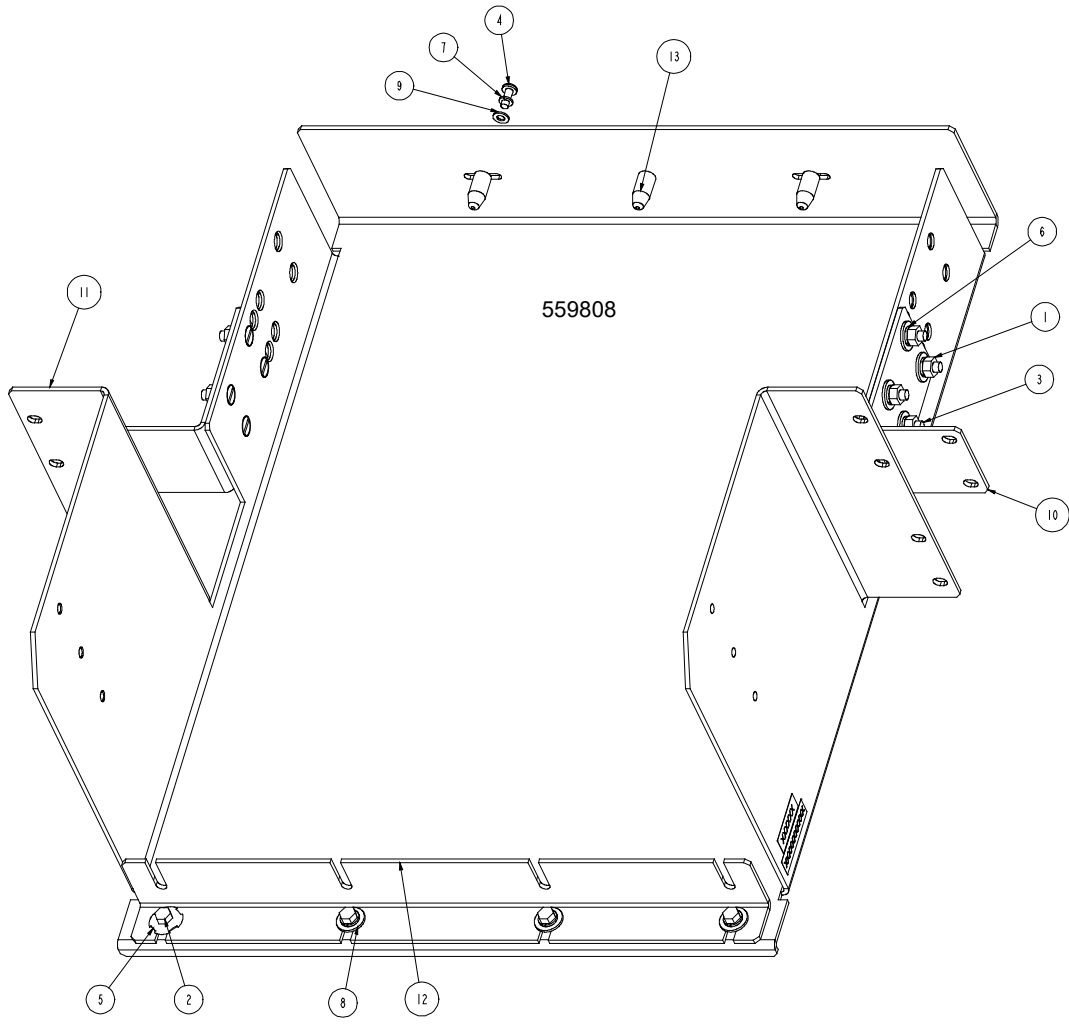
13	525095	SPACER, BATTERY	6
12	SXK2300175/1	TRAY, BATTERY	1
11	SXA2300174/1	BRACKET, BATTERY TRAY, MOUNTING	2
10	SXA2300173/1	BRACKET, BATTERY	1
9	214108100	FW, NO.10, .406 OD, .040 THK	6
8	214110200	FW, 1/4, .734 OD, .063 THK	11
7	215110900	LW, NO.10, .344 OD, .047 THK	6
6	215111100	LW, 1/4, .489 OD, .062 THK	11
5	215640800	GND.W, 1/4	1
4	221631400	PH, 10-32 X 1/2, SLOTTED	6
3	224430600	FH, 1/4-20 X 3/4	8
2	227640300	HHCS, 1/4-20 X 5/8	4
1	228557100	NUT, - HEX -, 1/4-20	8
INDEX	PART NO.	DESCRIPTION	QTY
PARTS/MATERIAL LIST			

Figure 3.10 559807 Battery Tray



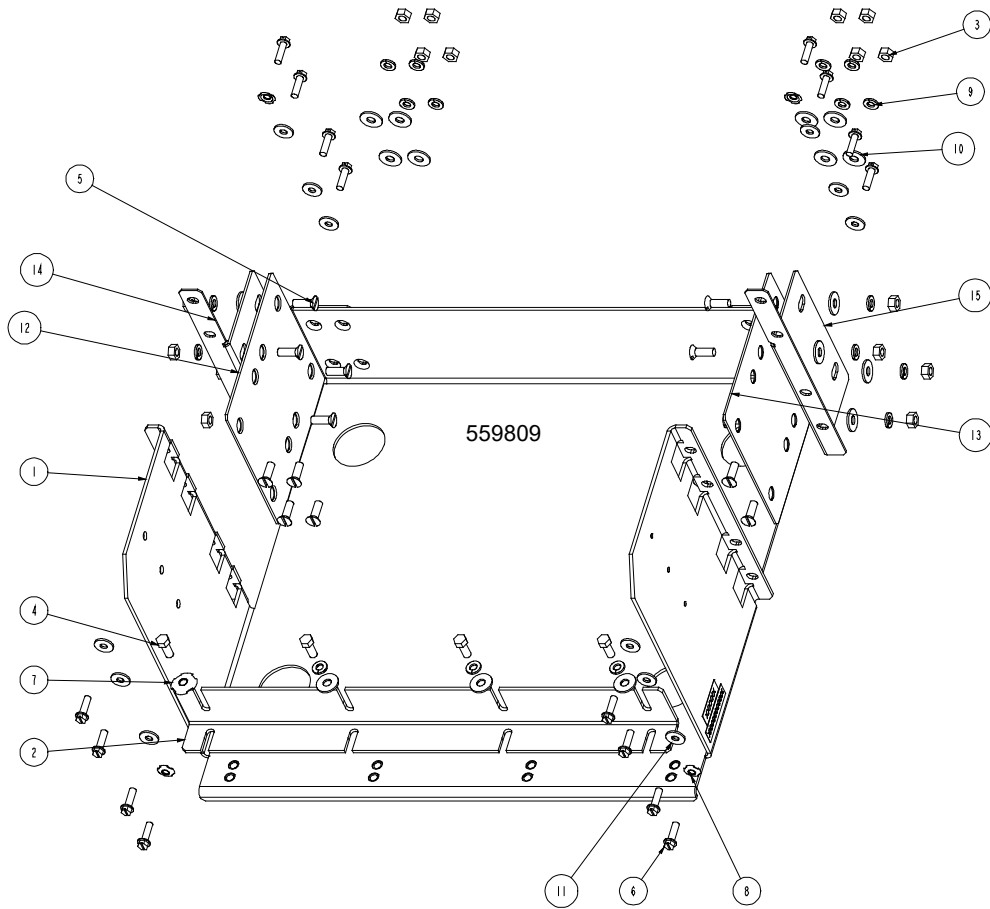
13	525095	SPACER, BATTERY	3
12	SXK2300172/1	TRAY, BATTERY, 23 IN, MTG	1
11	SXA2300171/1	BRKT, BAT. HLD, 19 IN	1
10	SXA2300170/1	BRKT, BAT TRAY, MTG	2
9	214108200	FW, NO.10, .562 OD, .040 THK	3
8	214110200	FW, 1/4, .734 OD, .063 THK	7
7	215110900	LW, NO.10, .344 OD, .047 THK	3
6	215111100	LW, 1/4, .489 OD, .062 THK	7
5	215640800	GND.W, 1/4	1
4	221631400	PH, 10-32 X 1/2, SLOTTED	3
3	224430600	FH, 1/4-20 X 3/4	4
2	227640300	HHCS, 1/4-20 X 5/8	4
1	228557100	NUT, - HEX -, 1/4-20	4
INDEX	PART NO.	DESCRIPTION	QTY
PARTS/MATERIAL LIST			

**Figure 3.11 559808 Battery Tray**



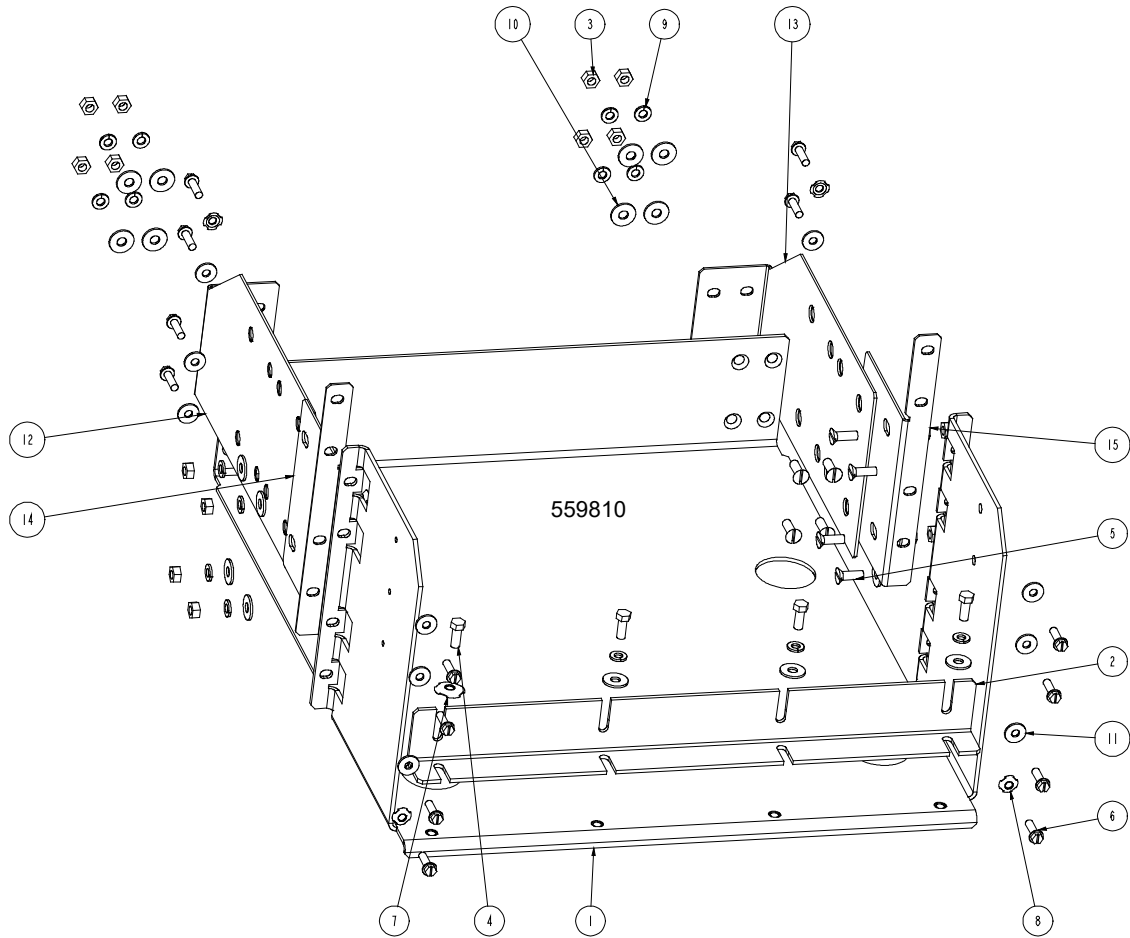
13	525095	SPACER, BATTERY	3
12	SXA2300177/1	BRACKET, BATTERY	1
11	SXK2300178/1	TRAY, BATTERY	1
10	SXA2300176/1	BRKT, BATTERY TRAY, MOUNTING	2
9	214108100	FW, NO.10, .406 OD, .040 THK	3
8	214110200	FW, 1/4, .734 OD, .063 THK	11
7	215110900	LW, NO.10, .344 OD, .047 THK	3
6	215111100	LW, 1/4, .489 OD, .062 THK	11
5	215640800	GND.W, 1/4	1
4	221631400	PH, 10-32 X 1/2, SLOTTED	3
3	224430600	FH, 1/4-20 X 3/4	8
2	227640300	HHCS, 1/4-20 X 5/8	4
1	228557100	NUT, - HEX -, 1/4-20	8
INDEX	PART NO.	DESCRIPTION	QTY
PARTS/MATERIAL LIST			

Figure 3.12 559809 Battery Tray



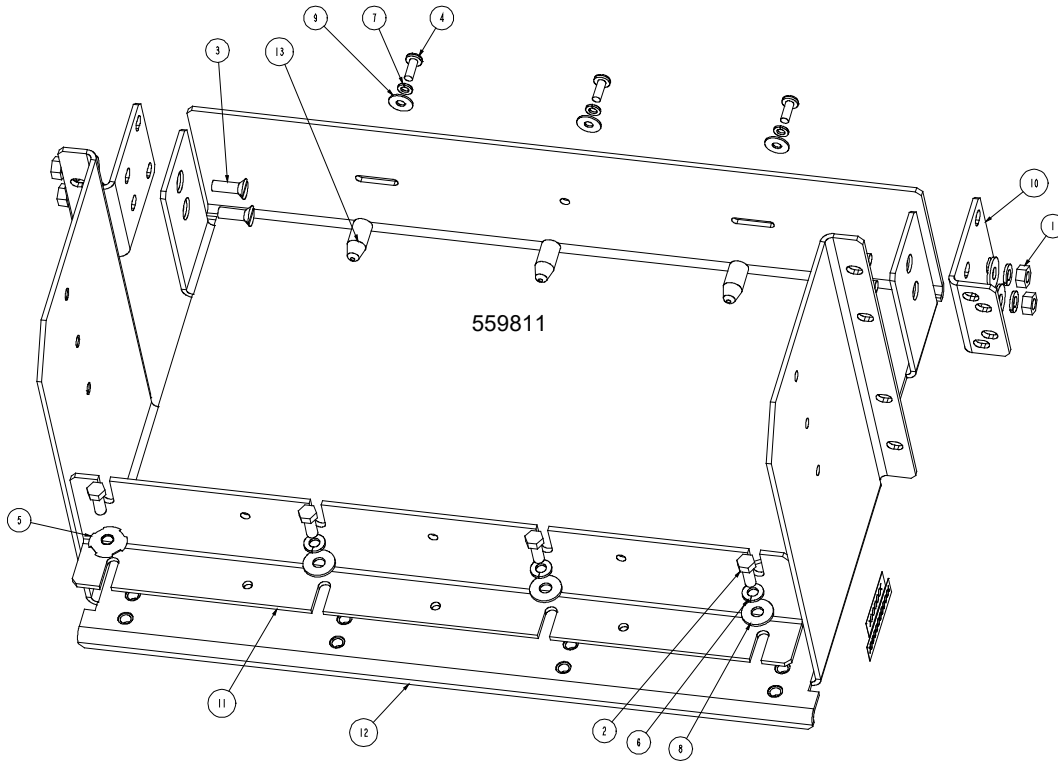
15	565089	BRKT, BATT TRAY, RIGHT MTG	1
14	565090	BRKT, BATT TRAY, LEFT MTG	1
13	565091	BRKT, BATT TRAY, RIGHT	1
12	565092	BRKT, BATT TRAY, RIGHT	1
11	214109200	FW, NO.12, .625 OD, .063 THK	12
10	214110200	FW, 1/4, .734 OD, .063 THK	19
9	215111100	LW, 1/4, .489 OD, .062 THK	19
8	215640600	GND.W, 10/12	4
7	215640800	GND.W, 1/4	1
6	218710600	TFHH, 12-24 X 3/4	16
5	224430600	FH, 1/4-20 X 3/4	16
4	227640300	HHCS, 1/4-20 X 5/8	4
3	228557100	NUT, - HEX -, 1/4-20	16
2	SXA2300177/1	BRACKET, BATTERY	1
1	SXK2300200/1	TRAY, BATTERY, 19" MTG	1
INDEX	PART NO.	DESCRIPTION	QTY
PARTS/MATERIAL LIST			

**Figure 3.13 559810 Battery Tray**



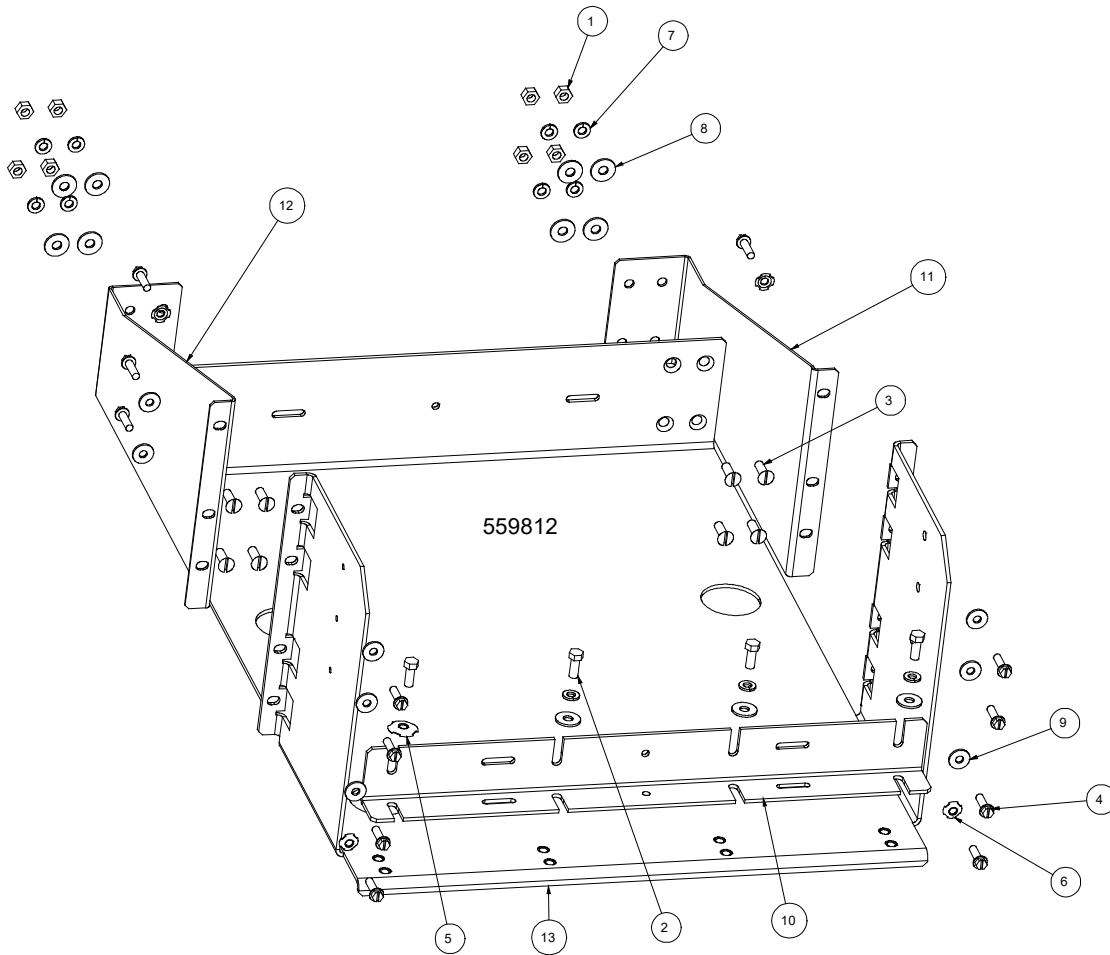
15	564857	BRKT, BATT TRAY, RIGHT MTG	1
14	564858	BRKT, BATT TRAY, LEFT MTG	1
13	564859	BRKT, BATT TRAY, RIGHT	1
12	564860	BRKT, BATT TRAY, LEFT	1
11	214109200	FW, NO.12, .625 OD, .063 THK	12
10	214110200	FW, 1/4, .734 OD, .063 THK	19
9	215111100	LW, 1/4, .489 OD, .062 THK	19
8	215640600	GND.W, 10/12	4
7	215640800	GND.W, 1/4	1
6	218710600	TFHH, 12-24 X 3/4	16
5	224430600	FH, 1/4-20 X 3/4	16
4	227640300	HHCS, 1/4-20 X 5/8	4
3	228557100	NUT, - HEX -, 1/4-20	16
2	SXA2300177/1	BRACKET, BATTERY	1
1	SXK2300193/1	TRAY, BATTERY, 19" MTG	1
INDEX	PART NO.	DESCRIPTION	QTY
PARTS/MATERIAL LIST			

Figure 3.14 559811 Battery Tray



13	525095	SPACER, BATTERY	3
12	SXK2300197/1	TRAY, BATTERY, 19 IN, MTG	1
11	SXA2300171/1	BRKT, BAT. HLDR, 19 IN	1
10	SXA2300196/1	BRKT, BAT TRAY, MTG	2
9	214108200	FW, NO.10, .562 OD, .040 THK	3
8	214110200	FW, 1/4, .734 OD, .063 THK	7
7	215110900	LW, NO.10, .344 OD, .047 THK	3
6	215111100	LW, 1/4, .489 OD, .062 THK	7
5	215640800	GND.W, 1/4	1
4	221631400	PH, 10-32 X 1/2, SLOTTED	3
3	224430600	FH, 1/4-20 X 3/4	4
2	227640300	HHCS, 1/4-20 X 5/8	4
1	228557100	NUT, - HEX -, 1/4-20	4
INDEX	PART NO.	DESCRIPTION	QTY
PARTS/MATERIAL LIST			

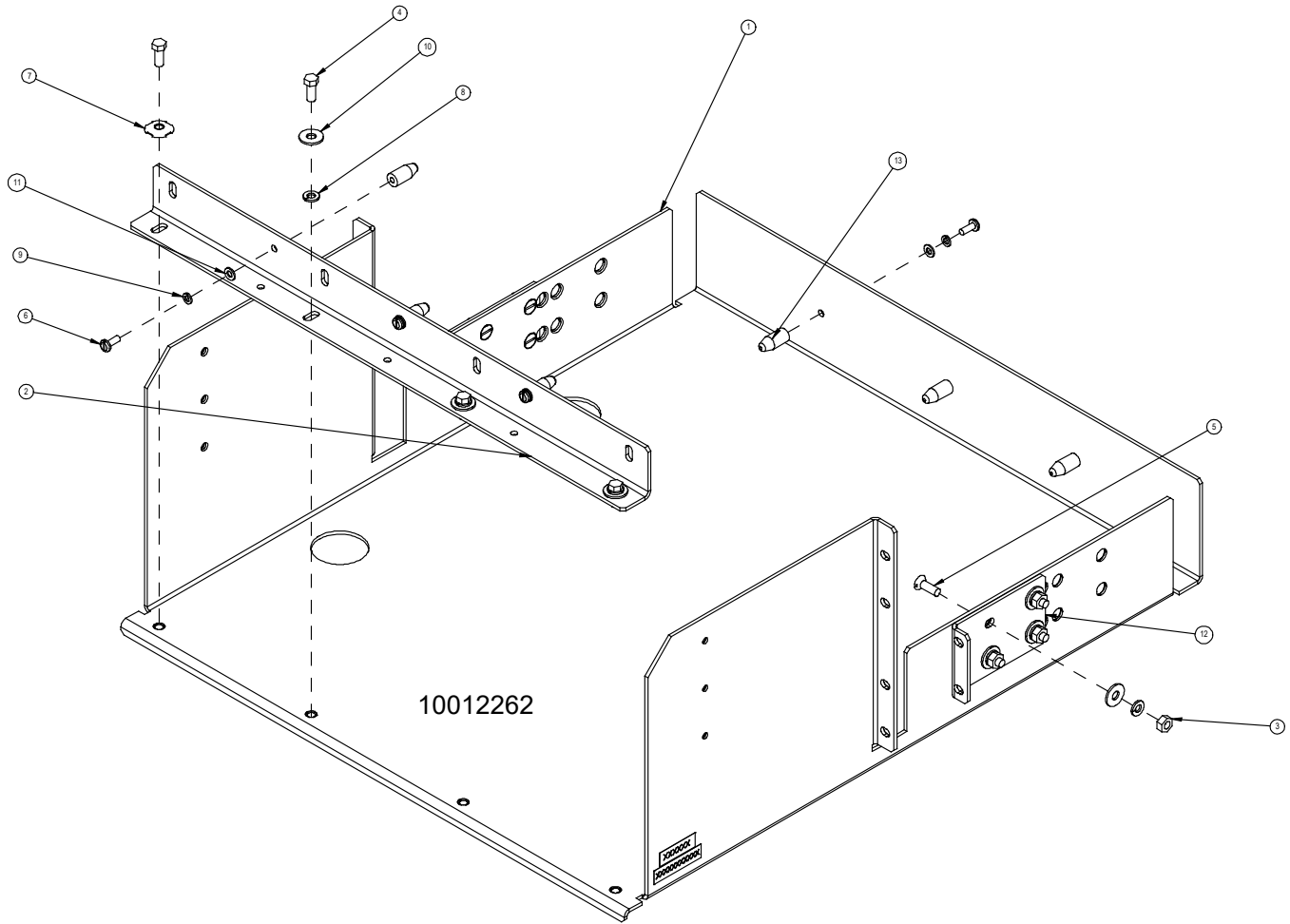
Figure 3.15 559812 Battery Tray



13	SXK2300204/1	TRAY, BATTERY, 19" MTG	1
12	SXA2300203/1	BRKT, BATT TRAY, LEFT, MTG	1
11	SXA2300202/1	BRKT, BATT TRAY, RIGHT, MTG	1
10	SXA2300205/1	BRACKET, BATTERY	1
9	214109200	FW, NO.12, .625 OD, .063 THK	10
8	214110200	FW, 1/4, .734 OD, .063 THK	11
7	215111100	LW, 1/4, .489 OD, .062 THK	11
6	215640600	GND.W, 10/12	4
5	215640800	GND.W, 1/4	1
4	218710600	TFHH, 12-24 X 3/4	14
3	224430600	FH, 1/4-20 X 3/4	8
2	227640300	HHCS, 1/4-20 X 5/8	4
1	228557100	NUT, - HEX -, 1/4-20	8
INDEX	PART NO.	DESCRIPTION	QTY
PARTS/MATERIAL LIST			



Figure 3.16 10012262 Battery Tray



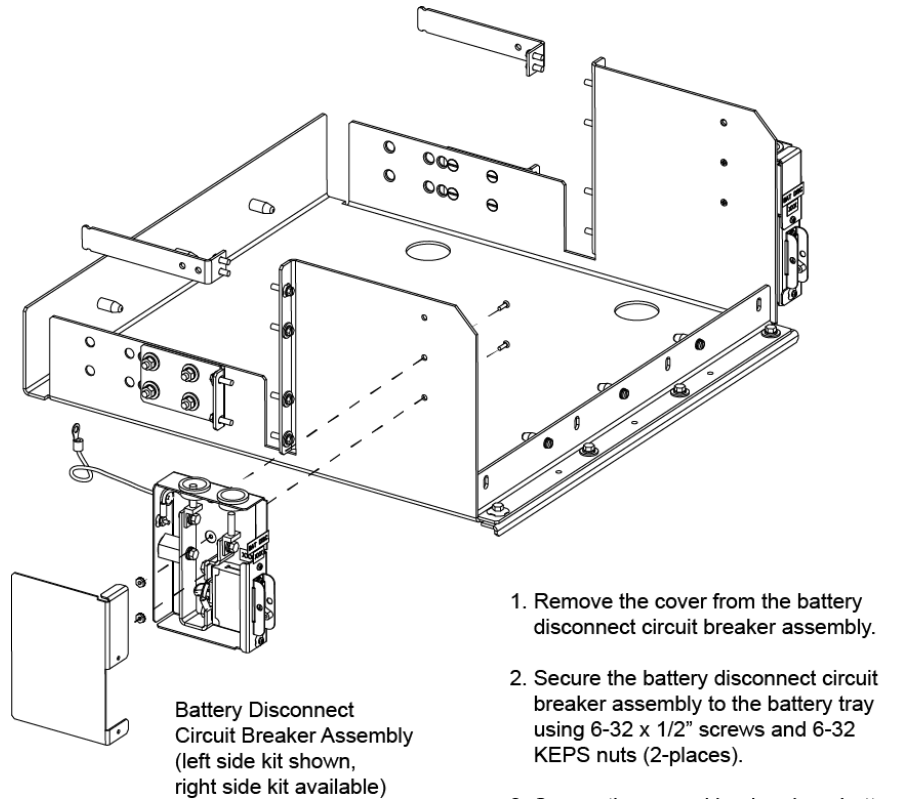
13	525095	SPACER, BATTERY,	6
12	SXA2300174_1	BRACKET, BATTERY TRAY, MOUNTING	2
11	214108100	FW, NO.10, .406 OD, .040 THK,	6
10	214110200	FW, 1/4, .734 OD, .063 THK,	11
9	215110900	LW, NO.10, .344 OD, .047 THK,	6
8	215111100	LW, 1/4, .489 OD, .062 THK,	11
7	215640800	GND.W, 1/4,	1
6	221631400	PH, 10-32 X 1/2, SLOTTED	6
5	224430600	FH, 1/4-20 X 3/4,	8
4	227640300	HHCS, 1/4-20 X 5/8,	4
3	228557100	NUT, - HEX -, 1/4-20	8
2	SXA2300173_1	BRACKET, BATTERY,	1
1	10012261	TRAY, BATTERY, 23"	1
INDEX	PART NO.	DESCRIPTION	QTY
PARTS/MATERIAL LIST			

## **Installing Optional Battery Disconnect Circuit Breaker onto a List 93, 94 Battery Tray**

### **Procedure**

1. To install an optional battery disconnect circuit breaker onto the battery tray perform the procedure detailed in Figure 3.17.
2. Battery tray wiring is shown in “Installing and Connecting Batteries in an Optional List 93 or 94 Battery Tray (if furnished)” on page 153.

**Figure 3.17** Installing Optional Battery Disconnect Circuit Breaker onto a List 93, 94 Battery Tray



### 3.3.3 Installing Optional 4-Post Flush Mounting Kit for Data Cabinets, P/N 559801

Adds strength when flush mounting the system in 19" mounting rails of a compliant data cabinet. Mounts to the inside surfaces of the data cabinet's vertical rails. Adjustable Depth: from 23.0 in [584 mm] to 30.0 in [762 mm]. Weight Load: 160 lbs.

#### **Procedure**

1. See Figure 3.18 for an assembly illustration.

### **Installing Field Expansion Module Mounting Assembly Spacer Kit, P/N 560075**

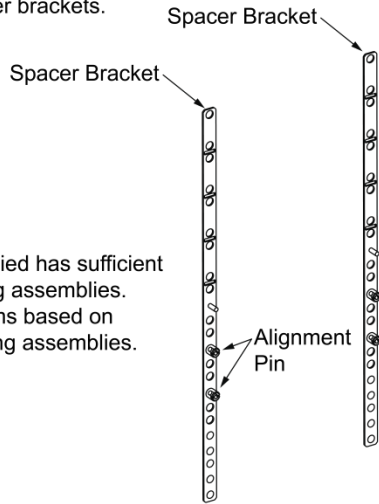
Provided with List 34, 36 field expansion module mounting assemblies is spacer kit (P/N 560075) for use with the 4-post flush mounting kit for data cabinets. Mounts to the inside surfaces of the data cabinet's vertical rails.



**NOTE!** *Installation instructions for the Field Expansion Module Mounting Assembly Spacer Kit, P/N 560075 is provided in the User Instructions (UM582137100).*

**Figure 3.18** Installing Optional 4-Post Flush Mounting Kit for Data Cabinets, P/N 559801 (cont'd on next page)

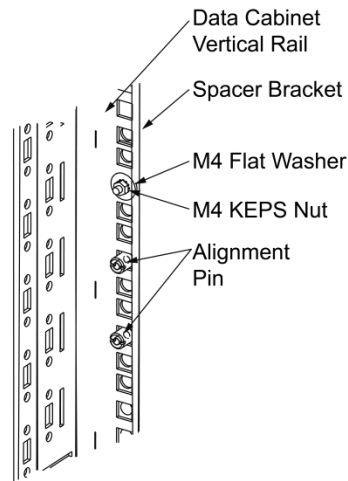
1. Assemble M4 alignment pins to spacer bracket.  
(2)-places on each of two spacer brackets.  
Torque: 18 in-lbs.



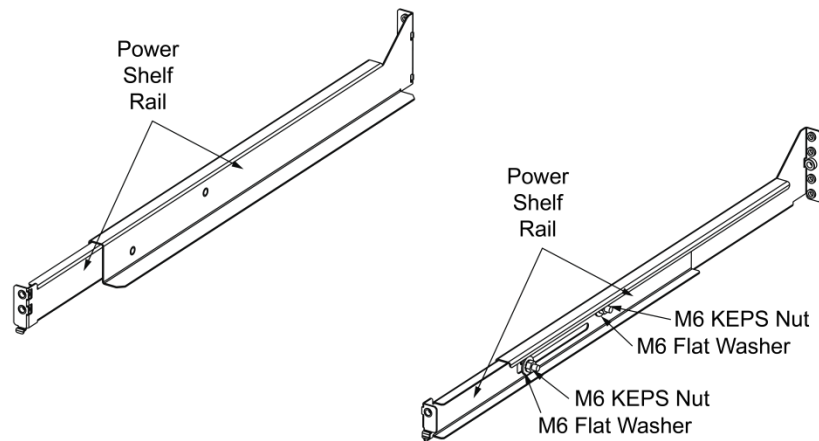
See next pages for additional detail.

2. Spacer bracket length as supplied has sufficient height for five module mounting assemblies.  
Cut spacer bracket to fit systems based on fewer than five module mounting assemblies.

3. Assemble spacer brackets to outside front surface of data cabinet vertical rails using M4 flat washer and M4 keps nut.  
(1)-places on each of two spacer brackets.  
Torque: 18 in-lbs.



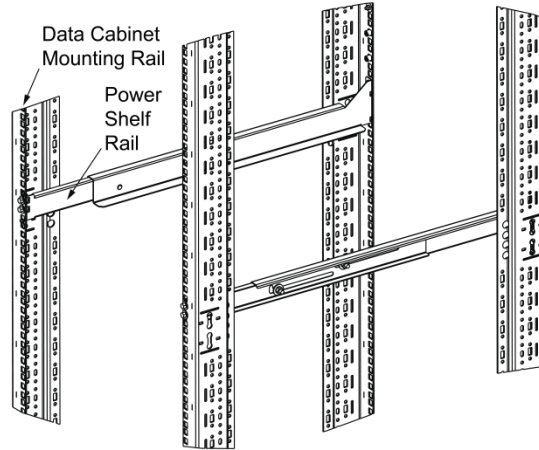
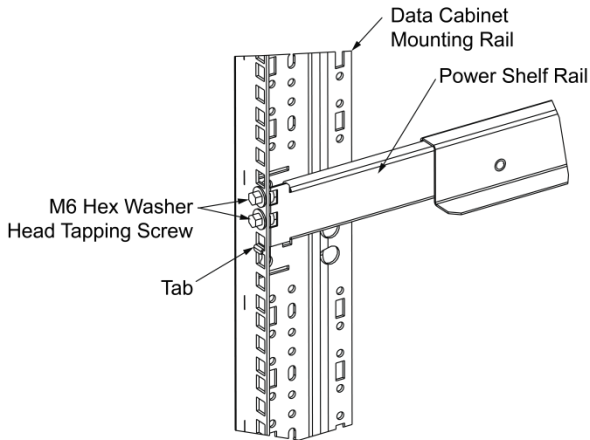
4. Assemble front and rear sections of power rails along the sides using M6 flat washer and M6 keps nut. Do not tighten.



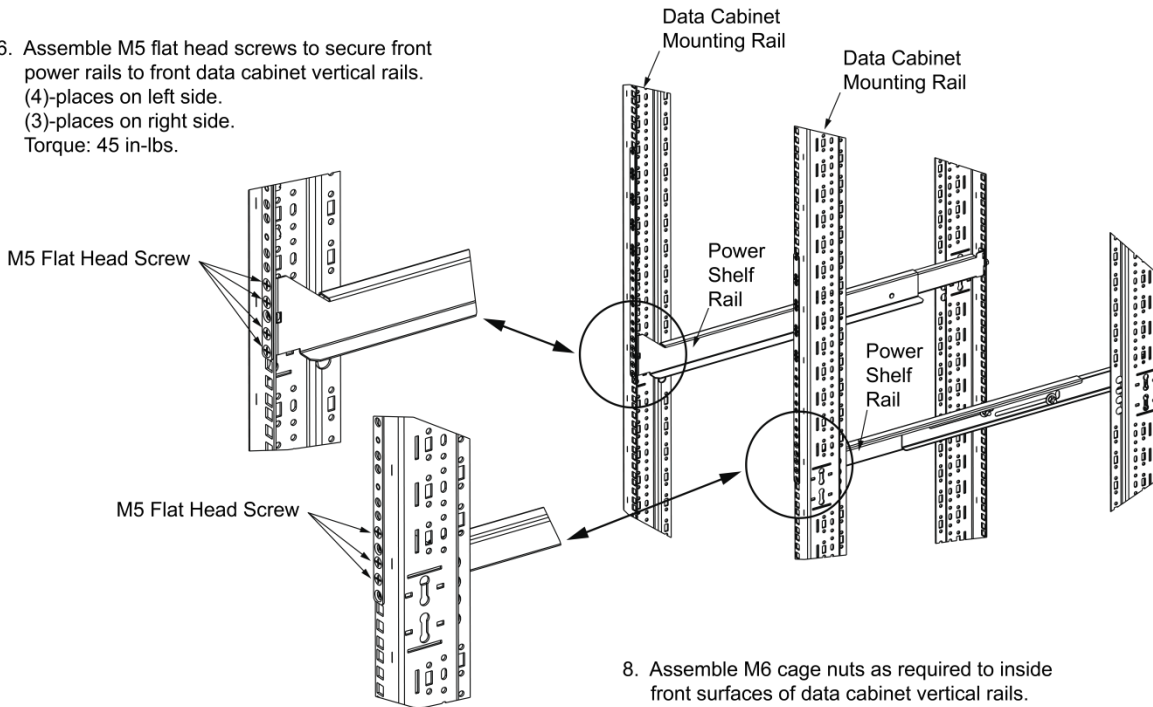
**Figure 3.18** Installing Optional 4-Post Flush Mounting Kit for Data Cabinets, P/N 559801 (cont'd from previous page, cont'd on next page)

- Engage tab of rear power rails into rear data cabinet rear vertical mounting rails.  
Assemble M6 hex washer screws.  
(2)-places per side. Torque: 60 in-lbs.

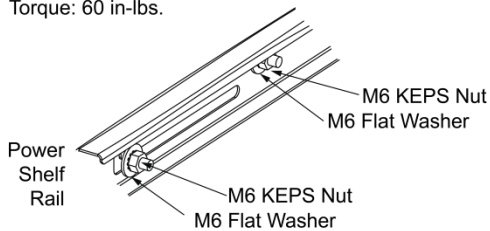
See next page for additional detail.



- Assemble M5 flat head screws to secure front power rails to front data cabinet vertical rails.  
(4)-places on left side.  
(3)-places on right side.  
Torque: 45 in-lbs.

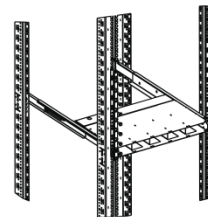


- Tighten M6 keps nut securing front and rear sections of power rails.  
Torque: 60 in-lbs.



- Assemble M6 cage nuts as required to inside front surfaces of data cabinet vertical rails.

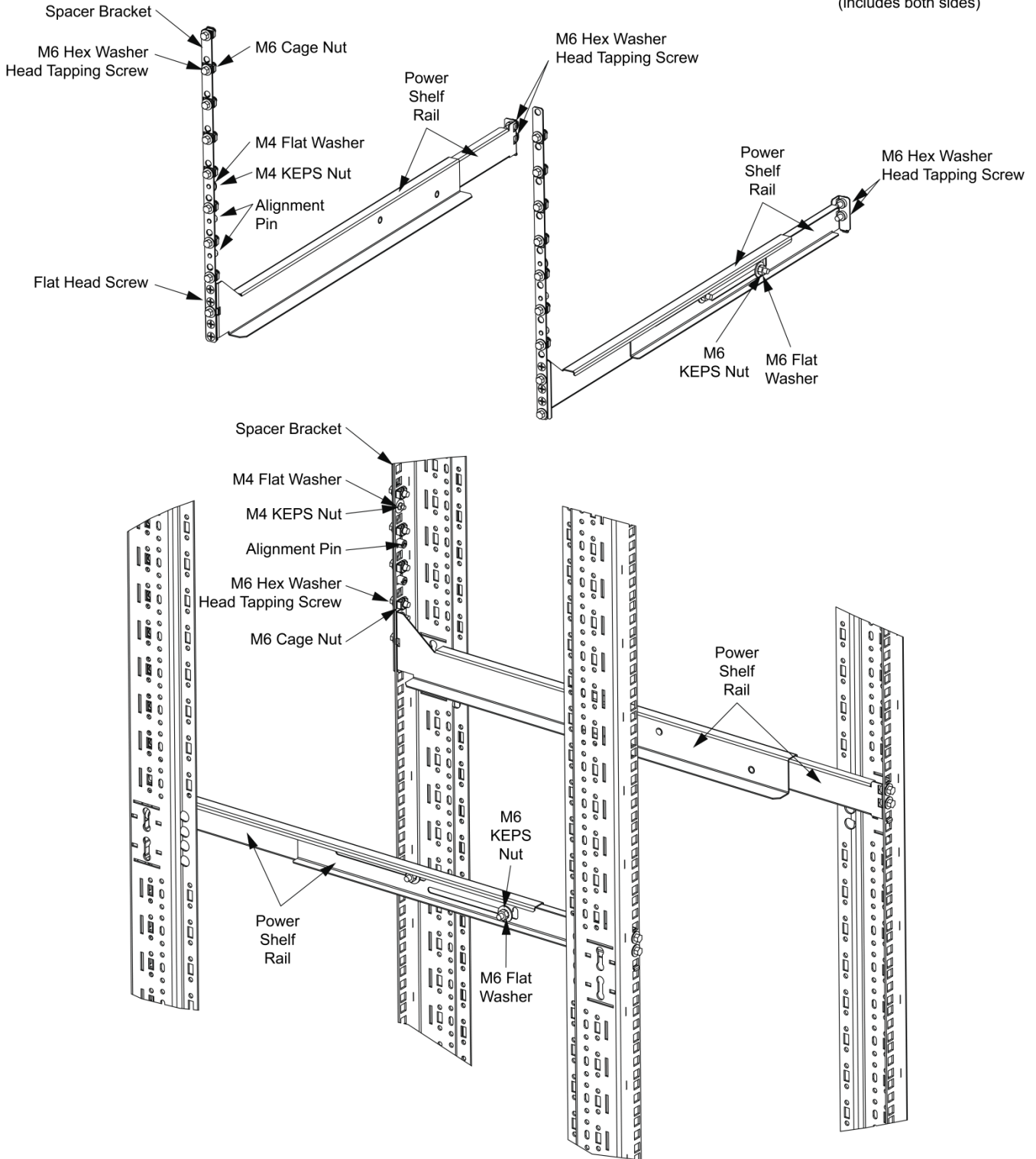
- Assemble 582137100 power system into data cabinet.  
Secure with M6 hex washer screws as required.  
Torque: 60 in-lbs.



**Figure 3.18** Installing Optional 4-Post Flush Mounting Kit for Data Cabinets, P/N 559801 (cont'd from previous page)

Note: Cut spacer bracket to fit system based on number of module mounting assemblies.

P/N 559801 Optional 4-Post  
Flush Mounting Kit for Data Cabinets  
(includes both sides)



### 3.4 Changing Orientation of Load Return Busbars Located in a List 20, 21, 25, or 26 Distribution Cabinet

The installer can rotate the load return busbar(s) located in a List 20, 21, 25, and 26 distribution cabinet from the factory default horizontal orientation (for wiring through the cabinet rear) to a vertical orientation (for wiring through the cabinet top).



**WARNING!** In a List 25, if you change the orientation in the field of the load return busbars (from horizontal to vertical), visually check that with the door closed the return busbar studs do not contact the door sheet metal surface. Instead, if contact is made it is with the insulation strip adhered on the door.



**CAUTION!** When performing any step in this procedure that requires removal or installation of hardware, use caution to ensure no hardware is dropped and left inside the cabinet; otherwise, service interruption or equipment damage may result.



**NOTE!** When performing any step in this procedure that requires removal of existing hardware, retain all hardware for use in subsequent steps.

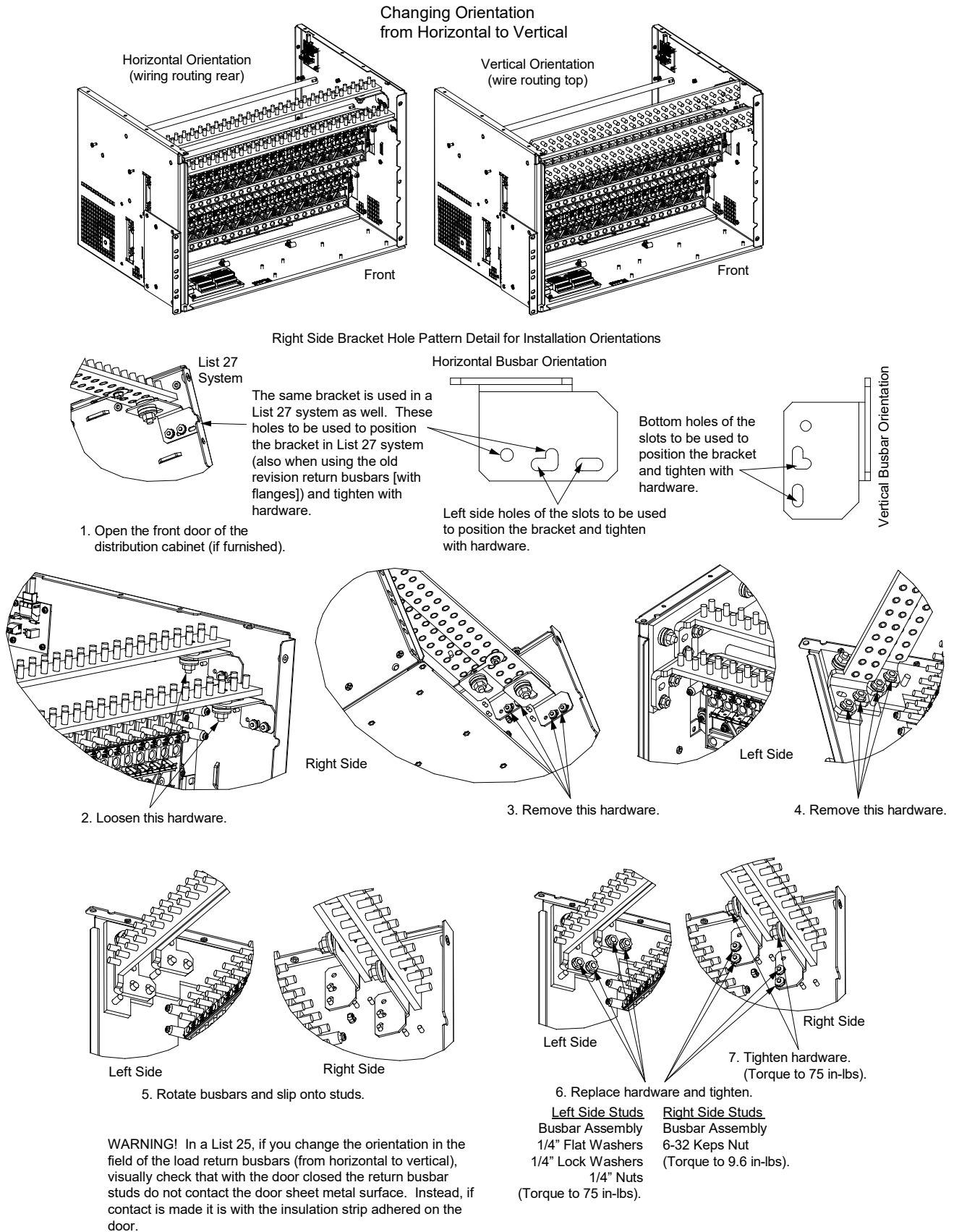


**NOTE!** With the load return bar in the vertical position, customer load lugs will stick out over the top of the cover.

#### **Procedure**

1. Perform the procedure detailed in Figure 3.19.

**Figure 3.19 Changing Orientation of Load Return Busbars Located in a List 20, 21, 25, or 26 Distribution Cabinet**





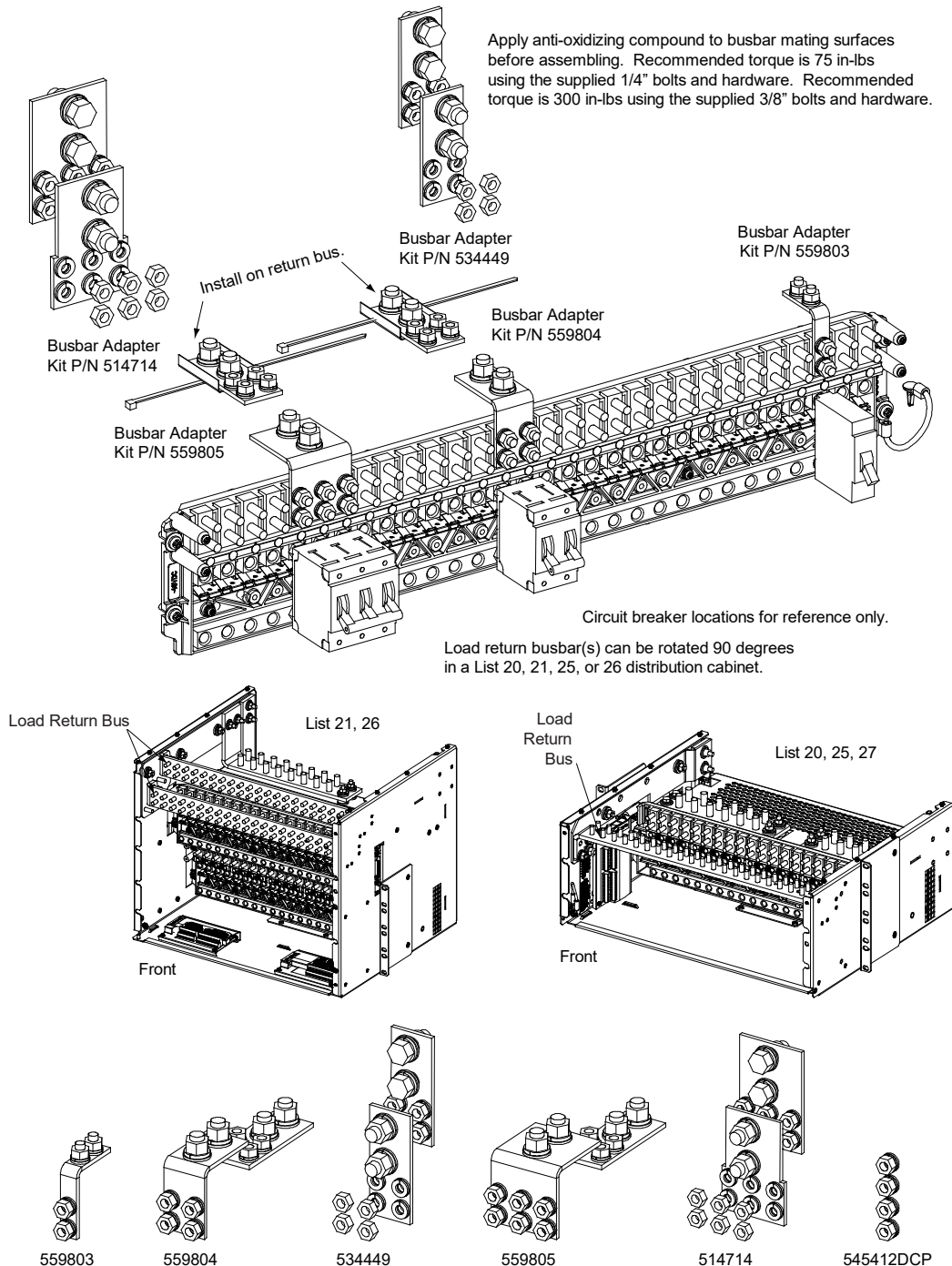
### 3.5 Installing Optional Lug Adapter Busbar Kits

These kits provide lug adapter busbars plus hardware for use with 2-pole and 3-pole circuit breakers. A right angle kit is also available for 1-pole devices.

#### Procedure

1. Refer to Figure 3.20 to install the lug adapter busbars kits.

**Figure 3.20** Installing Optional Lug Adapter Busbar Kits



### 3.6 Installing Circuit Breakers, Fuses, and Optional Transient Voltage Surge Suppressor (TVSS) Device(s)

Circuit breakers and/or fuses may have been factory installed for you. If so, verify their positions and sizes.

#### **Installing Bullet Nose Type Fuseholders and TPS/TLS Fuses in a List 20, 21, 25, 26, 27 Distribution Cabinet**



**CAUTION!** See SAG582137100 for temperature, sizing, and spacing restrictions.

Refer to the following procedure and install bullet nose type fuseholders and appropriately sized TPS/TLS fuses into the proper mounting positions in the distribution cabinet.

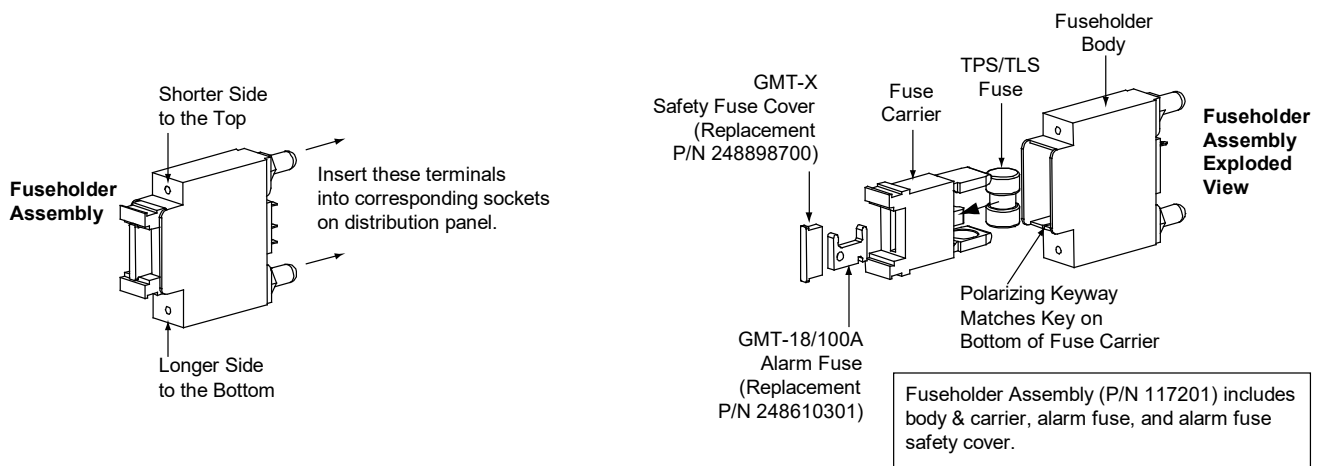
#### **Procedure**



**NOTE!** Refer to Figure 3.21 as this procedure is performed.

1. Orient the fuseholder as shown in Figure 3.21. Insert the terminals on the rear of the fuseholder into their corresponding sockets on the distribution panel. Ensure the alarm contact on the back of the fuseholder makes contact with the alarm terminal on the spring strip. Push fuseholder in firmly until fully seated in the distribution panel.
2. When all fuseholders are installed, install an appropriately sized TPS/TLS fuse in each. To do this, remove the fuse carrier from the mounted fuseholder body. Hold the fuseholder body while you pull the fuse carrier from the body. Slide the fuse in place between the contacts of the fuse carrier. When done, push the fuse carrier back into the fuseholder body. Note that a polarizing key on the bottom of the carrier prevents the carrier from being inserted upside down.
3. Verify that an 18/100 ampere alarm fuse is present in each fuseholder and that a plastic safety cover is installed on this fuse.
4. Record all fuse sizes on the label provided on the shield.

**Figure 3.21 Installing a Bullet Nose Type Fuseholder and TPS/TLS Fuse**



## Installing Bullet Nose Type Circuit Breakers in a List 20, 21, 25, 26, 27 Distribution Cabinet



**CAUTION!** See SAG582137100 for temperature, sizing, and spacing restrictions.

Refer to the following procedure and install appropriately sized bullet nose type circuit breakers into the proper mounting positions in the distribution cabinet.

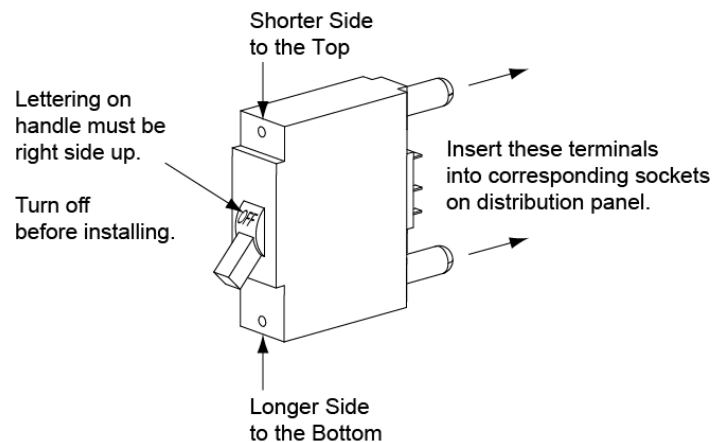
### Procedure



**NOTE!** Refer to Figure 3.22 as this procedure is performed.

1. Ensure that the circuit breaker is in the OFF position and is of the correct rating. Orient the circuit breaker as shown in Figure 3.22. Insert the terminals on the rear of the circuit breaker into their corresponding sockets on the distribution panel. Ensure the alarm contact on the back of the circuit breaker makes contact with the alarm terminal on the spring strip. Push distribution device in firmly until fully seated in the distribution panel.
2. Record all circuit breaker sizes on the label provided on the shield.

**Figure 3.22** Installing a Bullet Nose Type Circuit Breaker



## **Installing Optional Transient Voltage Surge Suppressor (TVSS) Device in a List 20, 21, 25, 26, 27 Distribution Cabinet**



**CAUTION!** See SAG582137100 for spacing restrictions.



**CAUTION!** The TVSS device occupies two mounting positions. Leave an additional empty mounting position between the TVSS device and any overcurrent protective device.

Refer to the following procedure and install an optional transient voltage surge suppressor (TVSS) device(s) into a distribution cabinet.

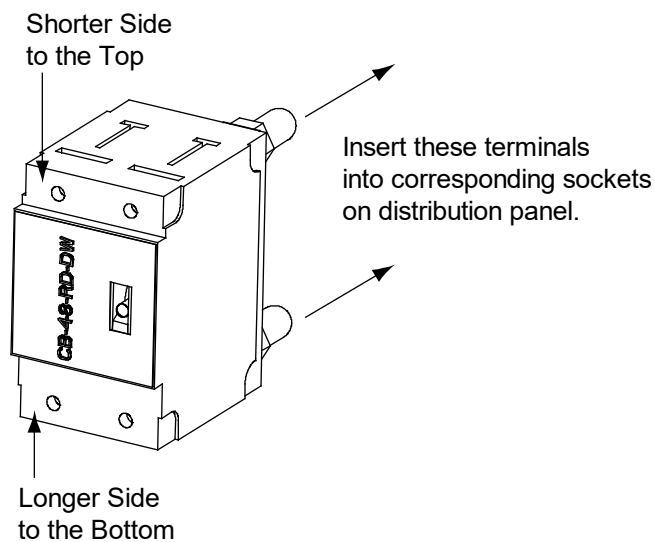
An optional Transient Voltage Surge Suppressor (TVSS) device is installed in the 'distribution device' mounting position of a bullet nose type distribution panel.

Install the TVSS device in the mounting position closest to the distribution panel's input busbar.

### **Procedure**

1. Install the TVSS device(s) as required. Refer to Figure 3.23.
2. Refer to "Optional Transient Voltage Surge Suppressor (TVSS) Device Ground Connection" and install the ground connection.

**Figure 3.23** Installing an Optional Transient Voltage Surge Suppressor (TVSS) Device

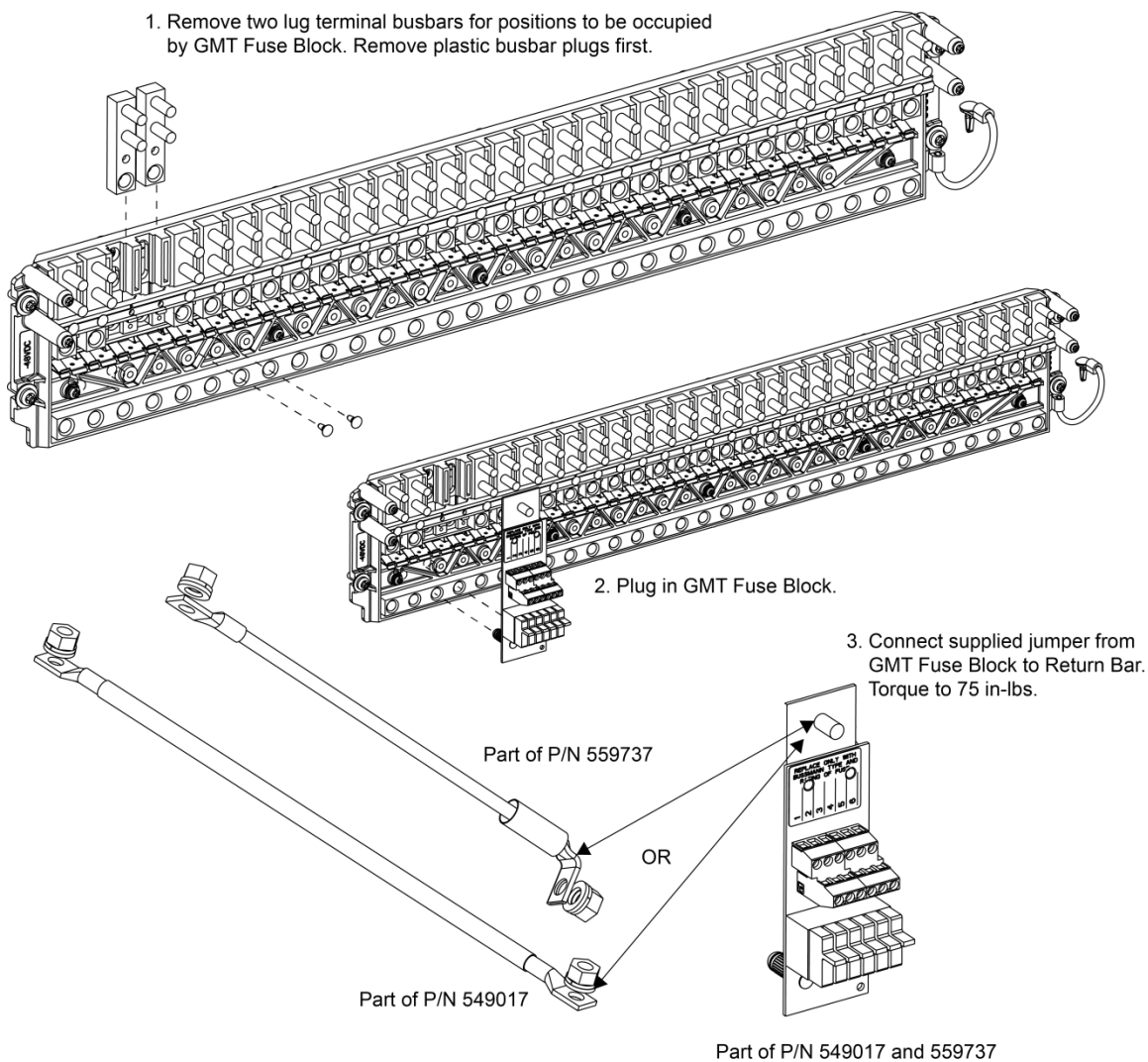


## **Installing an Optional Bullet Nose Type 6-Position GMT Distribution Fuse Block (P/N 559737 or 549017) in a List 20, 21, 25, 26, 27 Distribution Cabinet**

### **Procedure**

1. Refer to Figure 3.24 to install the GMT fuse block.
2. Install an appropriately sized GMT fuse in each fuse mounting position on the GMT fuse block as required. If dummy fuses are installed, first remove the dummy fuse.
  - a) Verify that dummy fuses are installed in all unused fuse positions on the GMT fuse block.
  - b) Verify that a plastic safety cover is installed on all GMT fuses on the GMT fuse block.
3. Record all fuse sizes installed in the GMT fuse block on the label provided on the GMT fuse block.

**Figure 3.24** Installing an Optional Bullet Nose Type 6-Position GMT Distribution Fuse Block (P/N 559737 or 549017) in a List 20, 21, 25, 26, 27 Distribution Cabinet

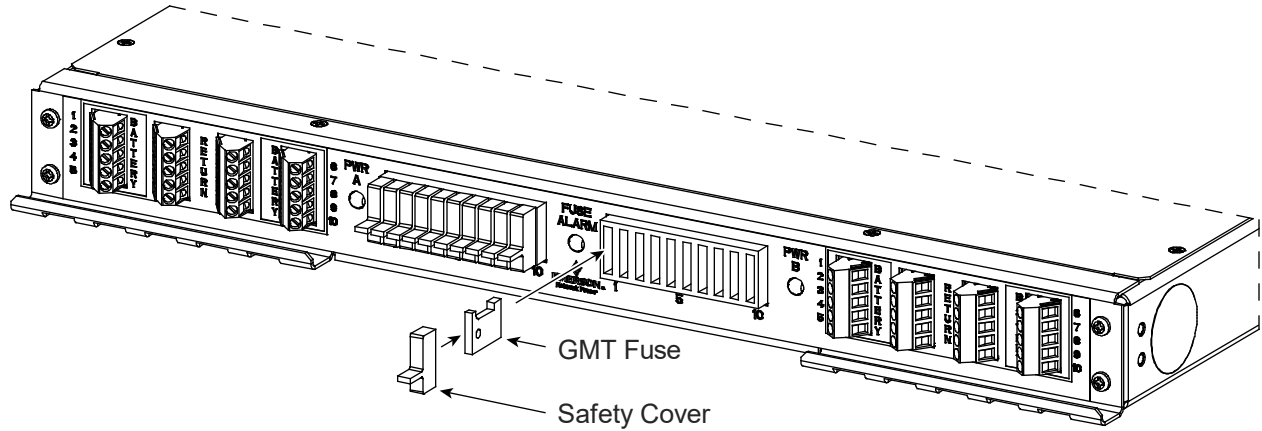


## Installing GMT Load Distribution Fuses in a List KG

### Procedure

1. Install correctly sized GMT fuses into the fuseholders located on the front of the distribution panel, as required. If a dummy fuse is installed, first remove the dummy fuse. Install a safety fuse cover over each GMT fuse. Install a dummy fuse in all unused fuse positions. See to Figure 3.25.

Figure 3.25 Installing GMT Load Distribution Fuses in a List KG



**Installing (Removing) a Circuit Breaker in an Optional List 60 Hybrid Connection Cabinet**

**CAUTION!** When performing any step in procedures that requires removal or installation of hardware, use caution to ensure no hardware is dropped and left inside the unit; otherwise service interruption or equipment damage may occur.



**CAUTION!** See SAG582137100 for temperature and sizing restrictions.

**Installing (Removing) a Blank Circuit Breaker Position Cover Panel Procedure**

1. Refer to Figure 3.26 to install/remove a blank circuit breaker position cover panel.

**Installing (Removing) a Circuit Breaker Procedure**

1. Refer to Figure 3.26 to install/remove a circuit breaker.  
Refer also to the following to install circuit breakers.  
Reverse the procedure to remove a circuit breaker.
2. Remove the front cover panels with the blank circuit breaker position cover panels.
3. Remove blank circuit breaker position cover panels as required. See Figure 3.26 for assembly details.
4. Provided with each circuit breaker is an alarm jumper (P/N RPM2300007/1) and a shunt jumper (P/N 520787). Attach the alarm jumper connectors to the back of the circuit breaker. Attach the shunt jumper connectors to the back of the circuit breaker. Wiring diagrams are provided in Figure 5.24 and Figure 5.25. The other ends to these jumpers will be connected in the procedure “Circuit Breaker Alarm and Shunt Monitoring Connections to an Optional List 60 Hybrid Connection Cabinet” starting on page 112.



**NOTE!** *Shunt leads must be terminated before switching breaker ON to avoid circuit fault.*

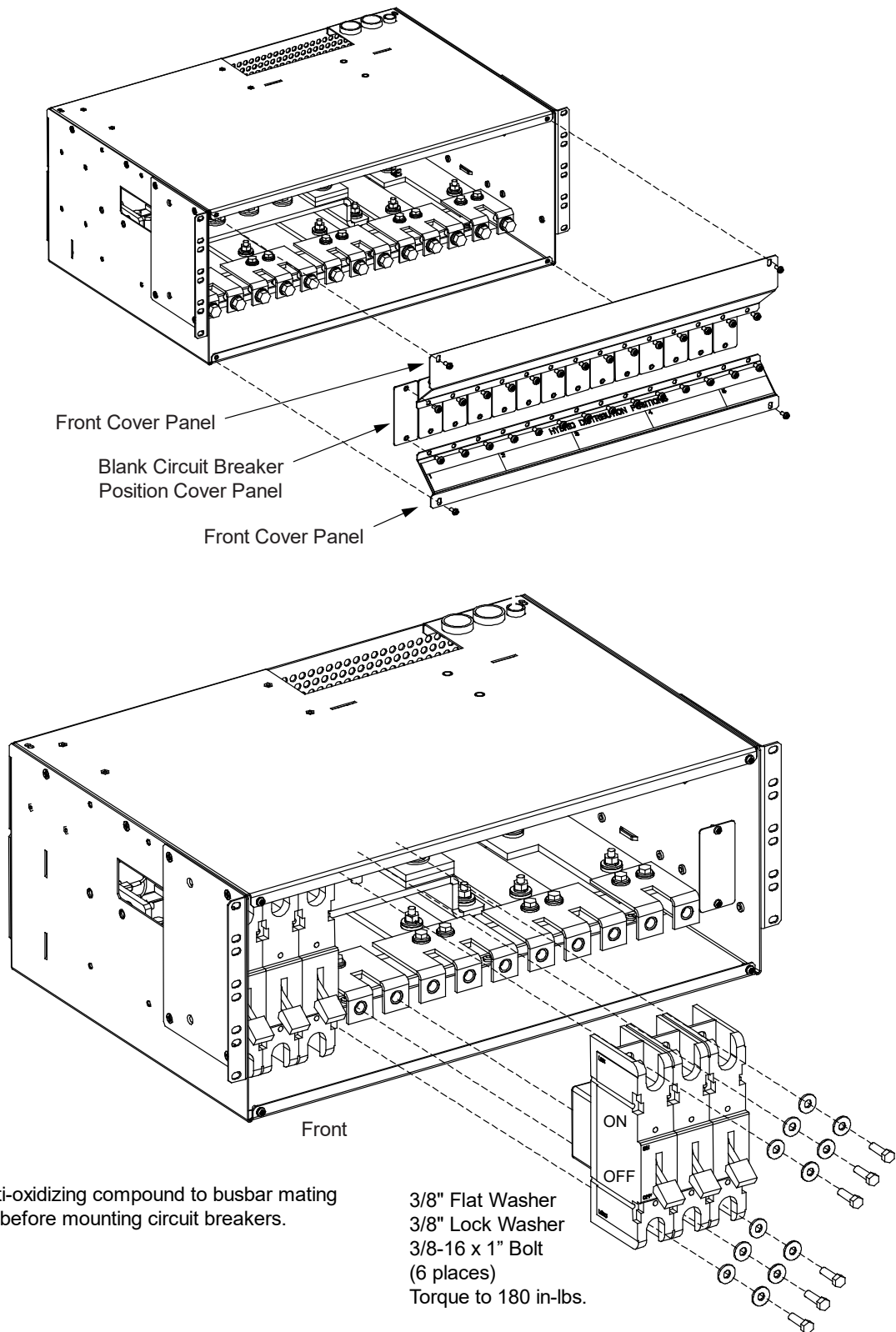
5. Ensure that the circuit breaker is in the OFF position, and is of the correct rating and type (electrical trip/mechanical trip or electrical trip only).
6. Apply anti-oxidizing compound to busbar mating surfaces on the hybrid connection cabinet and the circuit breaker.
7. Orient the circuit breaker over its mounting location.



**DANGER!** The bolts being installed in the following step may be at system potential. Use insulated tools.

8. Install the circuit breaker into its mounting position and secure with the provided hardware. Torque to 60 in-lbs.
9. Replace front cover panels.

Figure 3.26 Installing/Removing a Circuit Breaker in an Optional List 60 Hybrid Connection Cabinet





## **Installing (Removing) a Circuit Breaker in an Optional List 61 Solar Connection Cabinet**

### **Installing (Removing) a Blank Circuit Breaker Position Cover Panel Procedure**

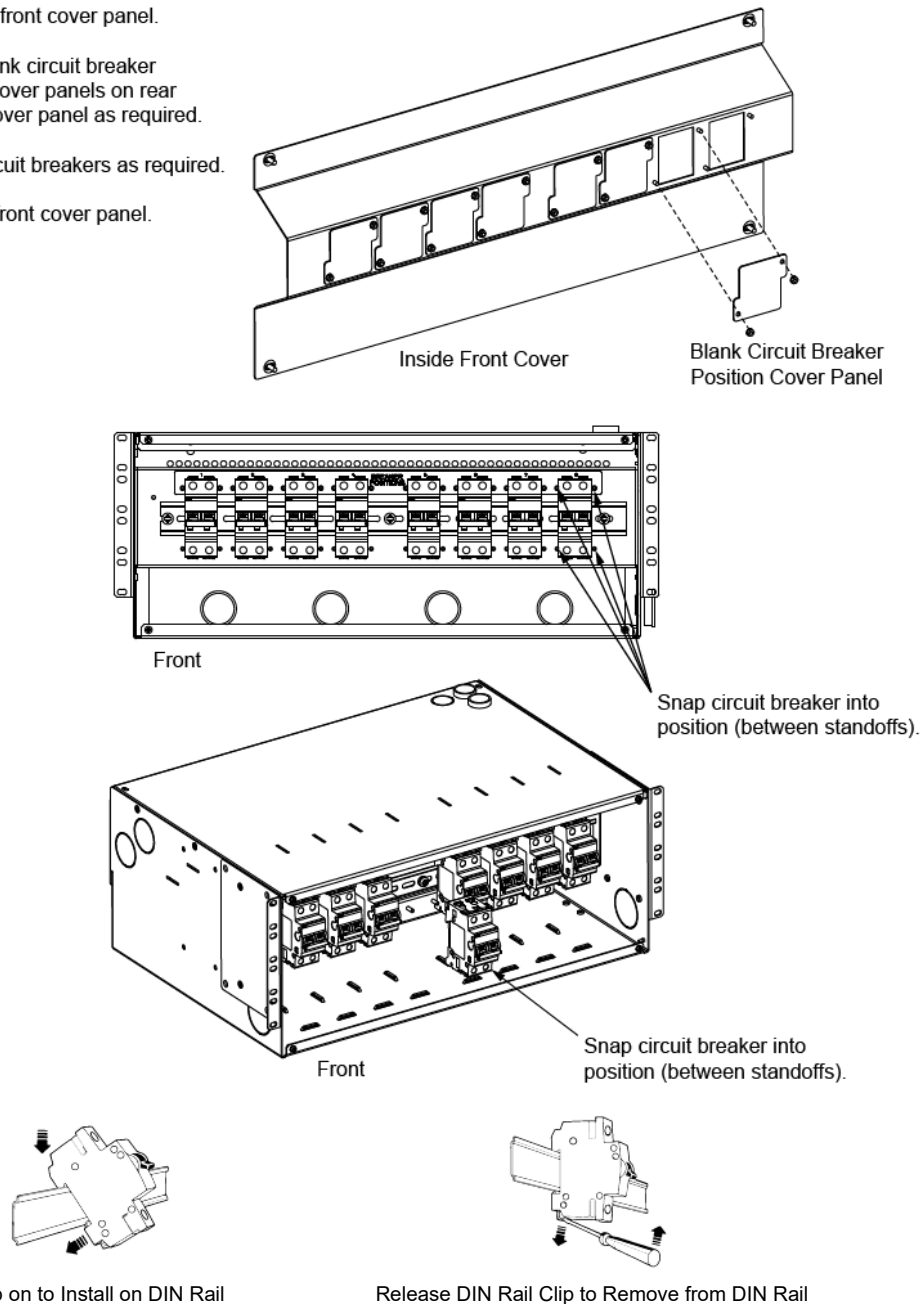
1. Refer to Figure 3.27 to install/remove a blank circuit breaker position cover panel.

### **Installing (Removing) a Circuit Breaker Procedure**

1. Refer to Figure 3.27 to install/remove a circuit breaker.

**Figure 3.27** Installing/Removing a Circuit Breaker in an Optional List 61 Solar Connection Cabinet

1. Remove front cover panel.
2. Install blank circuit breaker position cover panels on rear of front cover panel as required.
3. Install circuit breakers as required.
4. Replace front cover panel.



### 3.7 Vertiv™ NetSure™ SPD (Surge Protection Device) Field Installation Kit P/N 60051981 and P/N 60056702 Installation Instructions

#### 3.7.1 Kit Description

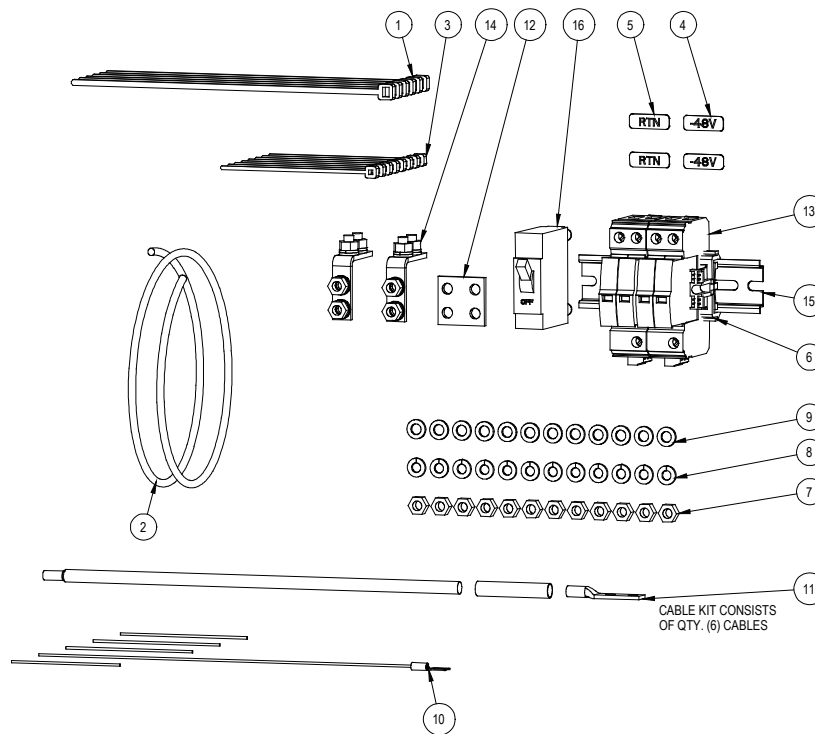
These instructions provide a step-by-step procedure to field install this kit and connect it to the power system if not already installed in the cabinet.

This kit provides SPD (Surge Protection Device) Assemblies which are installed external to the power system. Installation materials are also provided to connect the SPD devices to the power system.

#### 3.7.2 Kit Contents

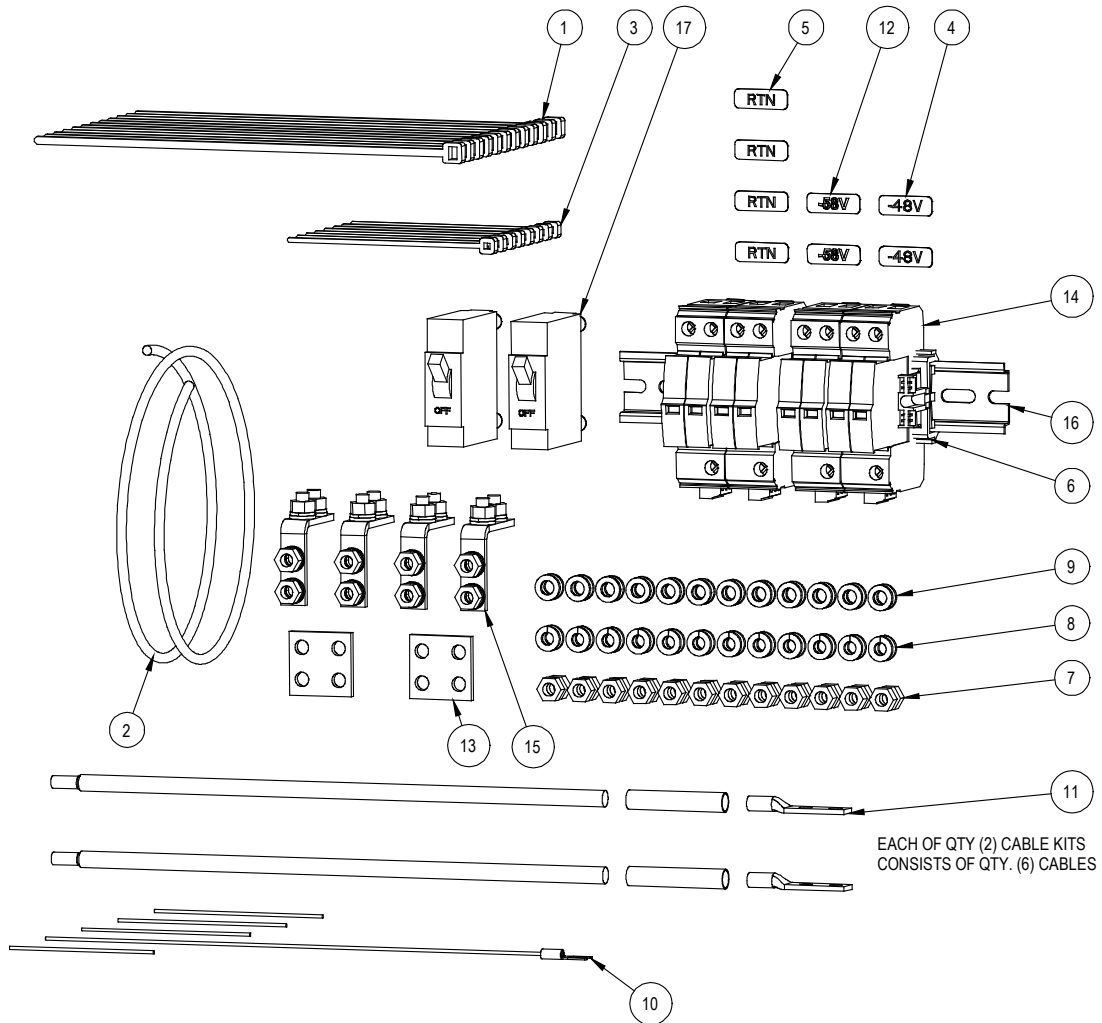
Figure 3.28 and Figure 3.29 lists the items furnished as a part of these kits. Before installing the kit, check the items furnished against those listed to ensure that there are no shortages.

Figure 3.28 60056702 Kit Contents



16	101609	BRKR, BULLET NOSE, 75A, 80VDC	1
15	144991	DIN RAIL, 35MM X 7.5MM, 5.00" LONG	1
14	559803	KIT, ADAPTER, 1 POLE	2
13	10034885	SPD, VAL-SEC-T2-2+0-48DC-FM, 2907865 PHOENIX	2
12	60016097	ADAPTER, 2 LUG, PLATE	1
11	60056563	KIT, CABLES, 6GA, SPD FIELD INSTALLATION	1
10	60056635	KIT, JUMPERS, SPD ALARM	1
9	214110100	FW, 1/4, .500 OD, .063 THK	12
8	215111100	LW, 1/4, .489 OD, .062 THK	12
7	228557100	NUT, - HEX -, 1/4-20	12
6	118175DCP	END CLAMP, DIN RAIL	2
5	545676DCP	LABEL, BUSBAR, RTN	2
4	545677DCP	LABEL, POWER BUS, -48V	2
3	P18298	TY-RAP, 4.0" LONG, EXPENSE / BULK	8
2	P59888A	CABLE, 2PAIR/24 SOLID TINNED, INSIDE WIRE	8 ft
1	P88555	CBL TIE, 8.5" LONG, 40 LBS, UV RESIST	6
INDEX	PART NO.	DESCRIPTION	QTY
PARTS/MATERIAL LIST			

Figure 3.29 60051981 Kit Contents



17	101609	BRKR, BULLET NOSE, 75A, 80VDC	2
16	121449	DIN RAIL, 35MM X 7.5MM, 5.00" LONG	1
15	559803	KIT, ADAPTER, 1 POLE	4
14	10034885	SPD, VAL-SEC-T2-2+0-48DC-FM, 2907865 PHOENIX	4
13	60016097	ADAPTER, 2 LUG, PLATE	2
12	60028661	LABEL, BUS BAR, -58V	2
11	60056563	KIT, CABLES, 6GA, SPD FIELD INSTALLATION	2
10	60056635	KIT, JUMPERS, SPD ALARM	1
9	214110100	FW, 1/4, .500 OD, .063 THK	24
8	215111100	LW, 1/4, .489 OD, .062 THK	24
7	228557100	NUT, - HEX -, 1/4-20	24
6	118175DCP	END CLAMP, DIN RAIL	3
5	545676DCP	LABEL, BUSBAR, RTN	4
4	545677DCP	LABEL, POWER BUS, -48V	2
3	P18298	TY-RAP, 4.0" LONG, EXPENSE / BULK	8
2	P59888A	CABLE, 2PAIR/24 SOLID TINNED, INSIDE WIRE	8 ft
1	P88555	CBL TIE, 8.5" LONG, 40 LBS, UV RESIST	12
INDEX	PART NO.	DESCRIPTION	QTY
PARTS/MATERIAL LIST			

### 3.7.3 Tools and Material Required

Table 3.1 lists the items required to install this kit.

**Table 3.1 Tools and Material Required**

Description
Wire Cutter (6 AWG, 24 AWG, 22 AWG)
Wire Insulation Strip Tool (6 AWG, 24 AWG, 22 AWG)
2-Hole Lug Crimp Tool for 6 AWG Flex Wire
7/16" Socket
Small Flat-Blade Screwdriver
#2 Phillips Screwdriver
Torque Wrench
Heat Gun (For Heat Shrink Tubing)

### 3.7.4 Installation Procedure

**THESE INSTRUCTIONS SHOULD BE READ THROUGH COMPLETELY BEFORE INSTALLING THE KIT.**

The following is a step-by-step procedure to install the kit. The procedure has been written for ease of use and to minimize the possibility of contact with potentially hazardous energy. This procedure should be performed in the sequence given, and each step should be completely read and fully understood before performing that step. Adhere to the “Important Safety Instructions” starting on page vii and also those presented in the following procedure. As each step of the procedure is completed, the box adjacent to the respective step should be checked. This will minimize the possibility of inadvertently skipping any steps. If the step is not required to be performed for your site, also check the box to indicate that it was read.

#### **Procedure**



**DANGER!** This procedure is performed on a LIVE system. Adhere to the “Important Safety Instructions” starting on page vii.



**NOTE!** As this procedure is performed, refer to Figure 3.30 and Figure 3.31 for typical power system wiring diagrams.

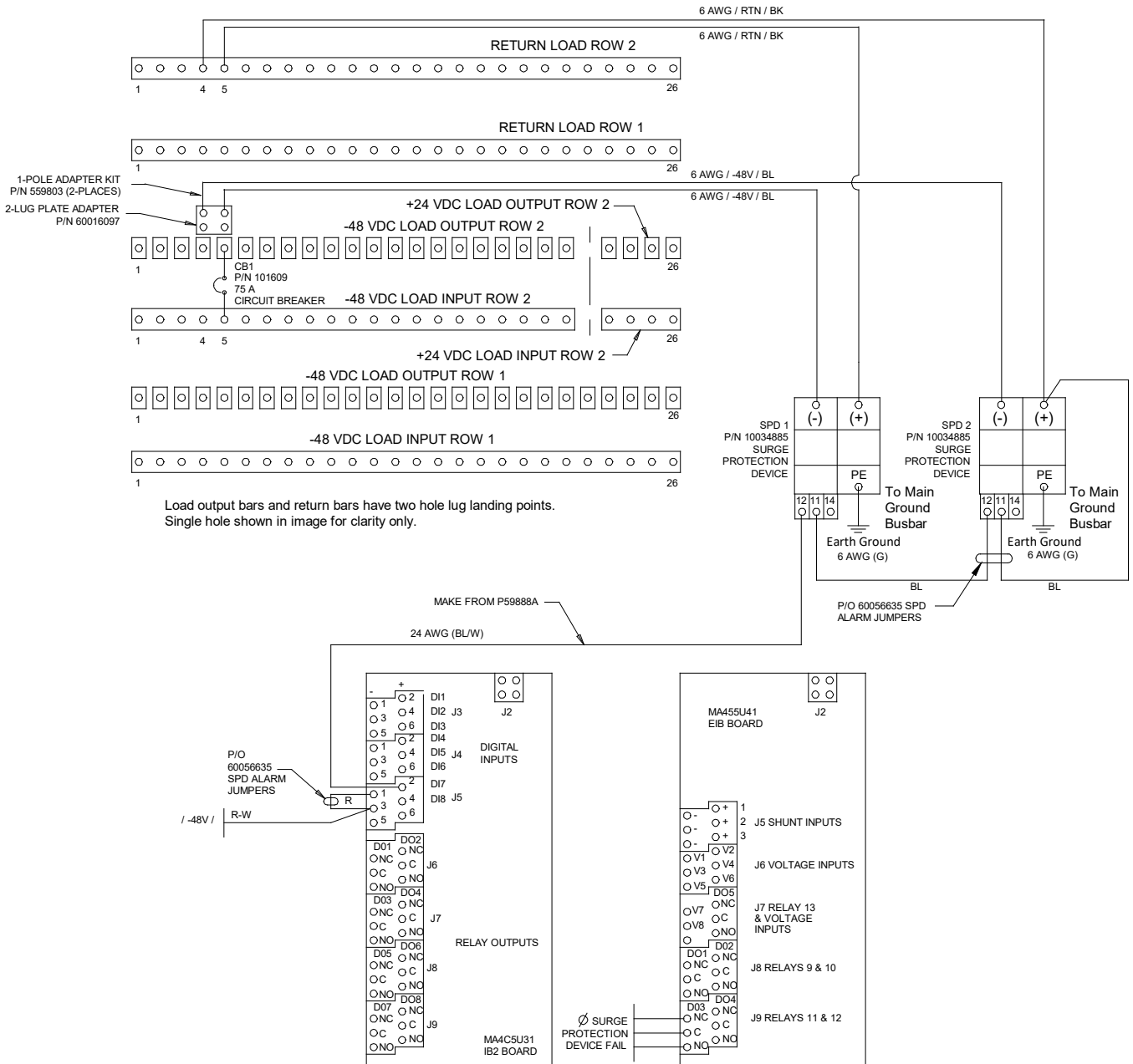


**NOTE!** Locate or relocate if already installed the DC Generator input kit in the bottom distribution row positions 23-26. Refer to the DC Generator input kit directions for more information.

- [ ] 1. Performing this procedure may activate external alarms. Do one of the following. If possible, disable these alarms. If these alarms cannot be easily disabled, notify the appropriate personnel to disregard any future alarms associated with this system while the procedure is being performed.
- [ ] 2. Ensure the enclosure the power system is mounted in has a proper site earth ground. Refer to the enclosure documentation.
- [ ] 3. Ensure the enclosure the power system is mounted in is properly grounded. Refer to the enclosure documentation.

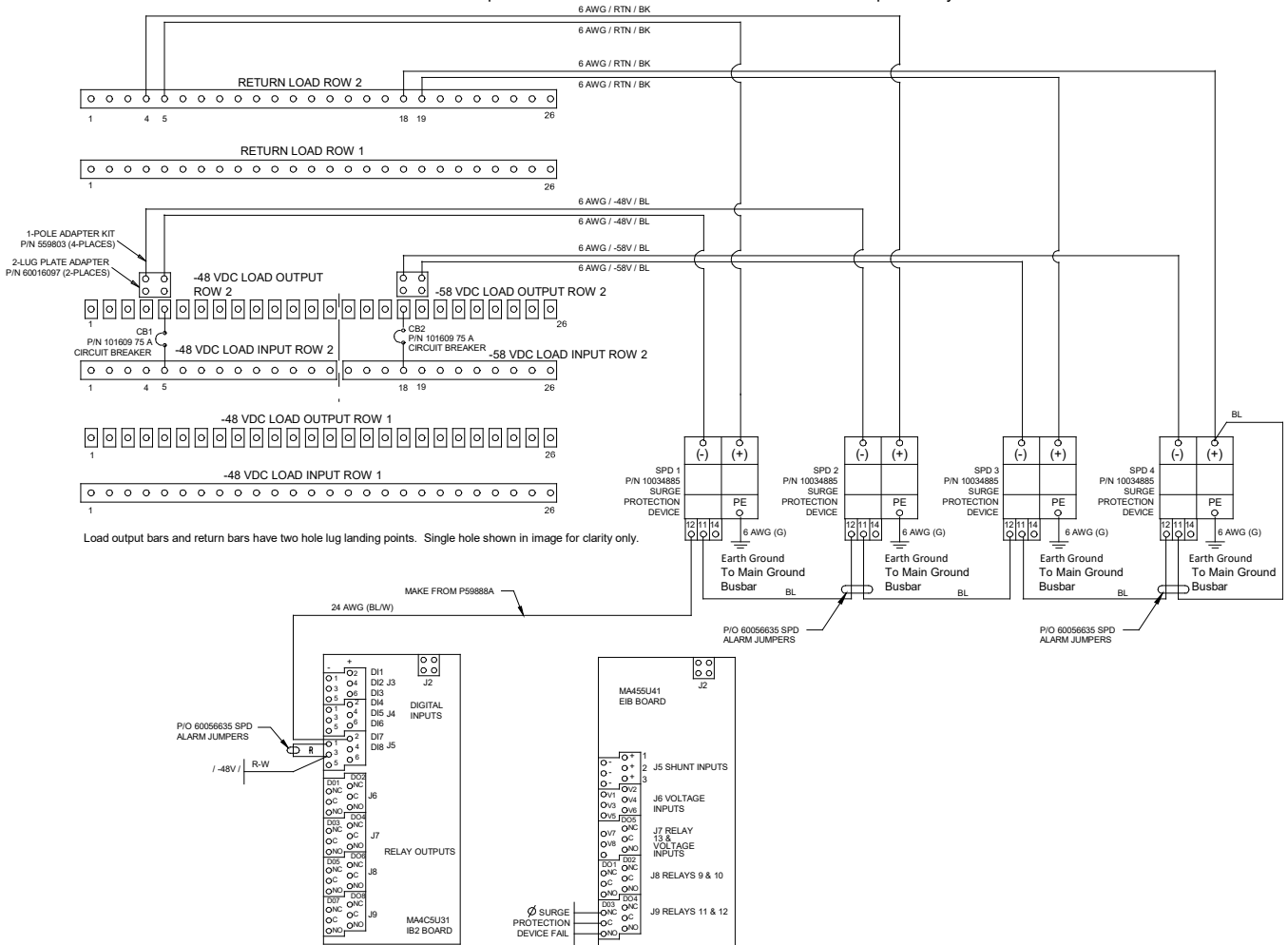
Figure 3.30 P/N 60056702 Surge Protection Device (SPD) Field Installation Kit Power and Alarm Wiring Diagram for -48 VDC and +24 VDC Power System

Note: For 582137100ZZ028 Only



**Figure 3.31 P/N 60051981 Surge Protection Device (SPD) Field Installation Kit Power and Alarm Wiring Diagram for -48 VDC and -58 VDC Power System**

Note: For 582137100500 or a 582137100Z028 plant that has been converted to a 582137100500 plant Only



- [ ] 4. Install the kit supplied DIN rail per site requirements. The SPDs will be mounted to the DIN rail. Typically install the DIN rail onto the enclosure the power system is mounted in. Customer must supply the DIN rail mounting hardware. Take the following into considerations when choosing a DIN rail mounting location:
  - Wire lengths for “+”, “-”, and “Earth Ground” must be minimized.
  - Tight bends in 6 AWG wire (less than 2” radius) must be avoided.
- [ ] 5. Slide the kit supplied SPD devices onto the DIN rail and secure at each end with a kit supplied DIN rail end clamp. Recommended torque for DIN rail end clamps is 15 in-lbs.
  - Note that for kit P/N 60056702 the two SPD devices are installed next to each other. See Figure 3.32 for a diagram.
  - Note that for kit P/N 60051981, two SPD devices are installed next to each other, then a DIN rail end clamp is installed and then the remaining two SPD devices are installed next to each other. See Figure 3.33 for a diagram.

Figure 3.32 Install SPD Devices to DIN Rail Kit P/N 60056702

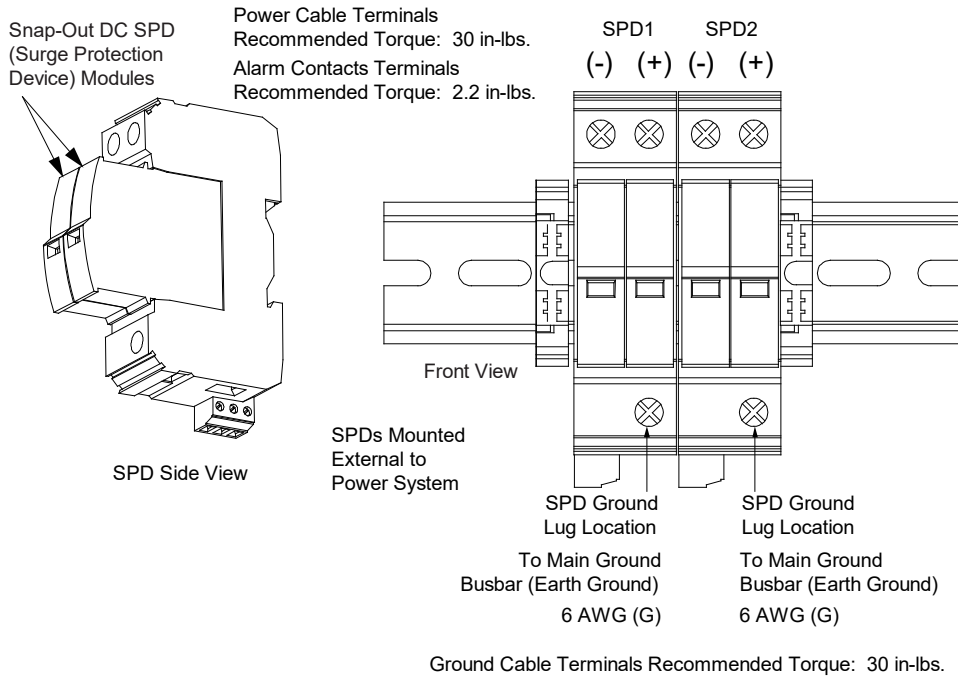
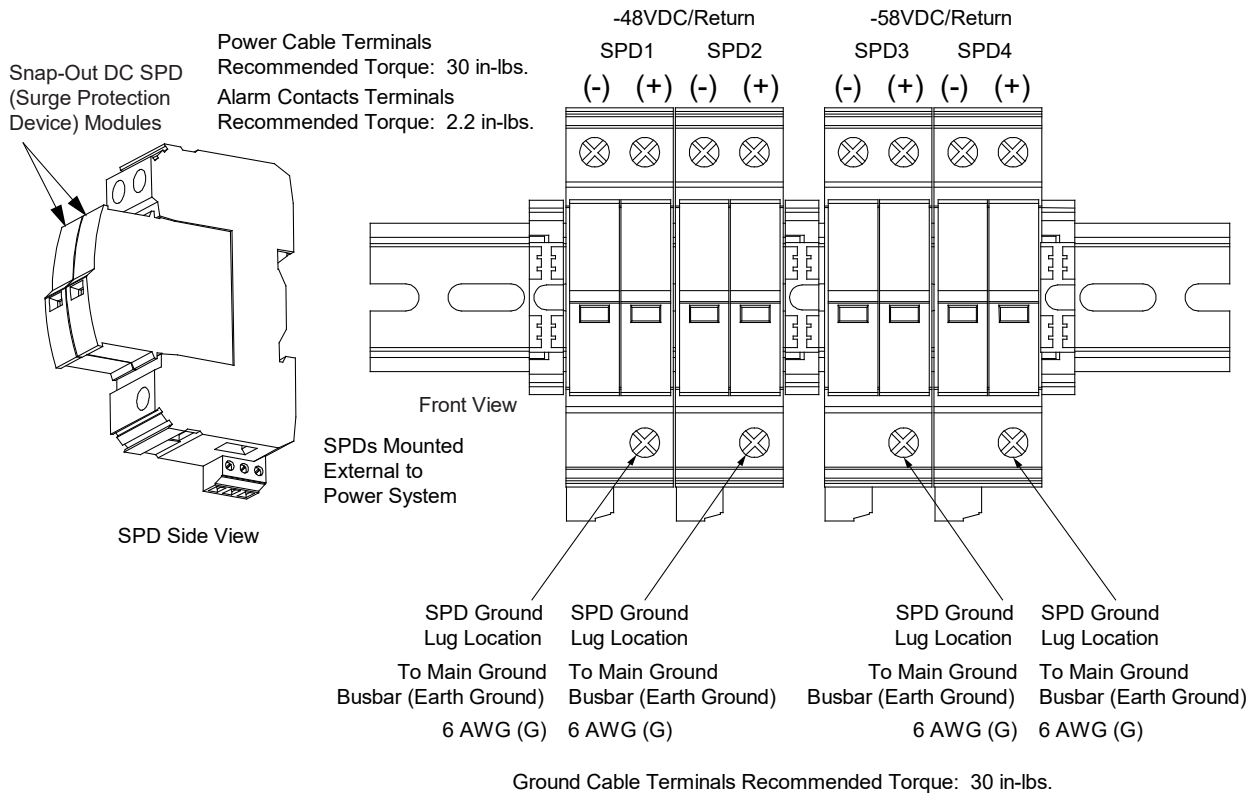


Figure 3.33 Install SPD Devices to DIN Rail Kit P/N 60051981



- [ ] 6. For kit P/N 60056702, install a kit supplied 75 A circuit breaker in the power system's -48 VDC distribution bus (typically position 5, in Row 2 (top) of the distribution cabinet for the 582137100ZZ028 and 582137100500).

For kit P/N 60051981, install a kit supplied 75 A circuit breaker in the power system's -48 VDC distribution bus (typically position 5, in Row 2 (top) of the distribution cabinet for the 582137100ZZ028 and 582137100500) and the remaining kit supplied 75 A circuit breaker in the power system's -58 VDC distribution bus (typically position 18, in Row 2 (top) of the distribution cabinet for the 582137100500).

Take the following into considerations when choosing a circuit breaker mounting location: SPD location and the need to minimize SPD power cable lengths.

- [ ] 7. Connect the alarm jumpers provided in the P/N 60056635 alarm jumper kit supplied with the SPD kit as shown in Figure 3.34.
  - a) Connect the SPD alarm contacts in series using the kit supplied blue alarm jumpers as shown in Figure 3.34. Recommended strip length is 0.25". Recommended torque is 2.2 in-lbs.
  - b) Connect SPD alarm contact terminal 11 of the last SPD to that SPD's "+" terminal as shown in Figure 3.34. Assemble blue alarm jumper with #10 spade lug to SPD "+" terminal slot (under the screw head). Terminal screw will be tightened later in the procedure after the black "+" 6 AWG wire is installed to the same terminal.
  - c) Jumper terminals J5-1 (DI7-) to J5-3 (DI8-) of the power system's IB2 controller interface board using the kit supplied red alarm jumper as shown in Figure 3.34. Recommended torque is 2.2 in-lbs.
- [ ] 8. Connect SPD alarm contact terminal 12 of the first SPD to the power system's IB2 controller interface board using the kit supplied alarm cable (P59888A) as shown in Figure 3.34.
  - a) Trim cable insulation by 1.25" from cable end and discard insulation. Keeping the blue/white wire, trim back the other three wires and discard.
  - b) Strip the blue/white wire by 0.25".
  - c) Assemble blue/white wire to SPD alarm terminal 12. Recommended torque is 2.2 in-lbs.
  - d) Route cable to IB2 board in the power system distribution unit. Cut the cable as required in order to reach IB2 DI7+ (IB2 terminal J5-2).
  - e) Trim cable insulation by 1.25" from cable end and discard insulation. Keeping the blue/white wire, trim back the other three wires and discard.
  - f) Strip the blue/white wire by 0.25".
  - g) Assemble blue/white wire to IB2 DI7+ (IB2 terminal J5-2). Recommended torque is 2.2 in-lbs.



Figure 3.34 Connect SPD Alarm Contacts Wiring (cont'd on next page)

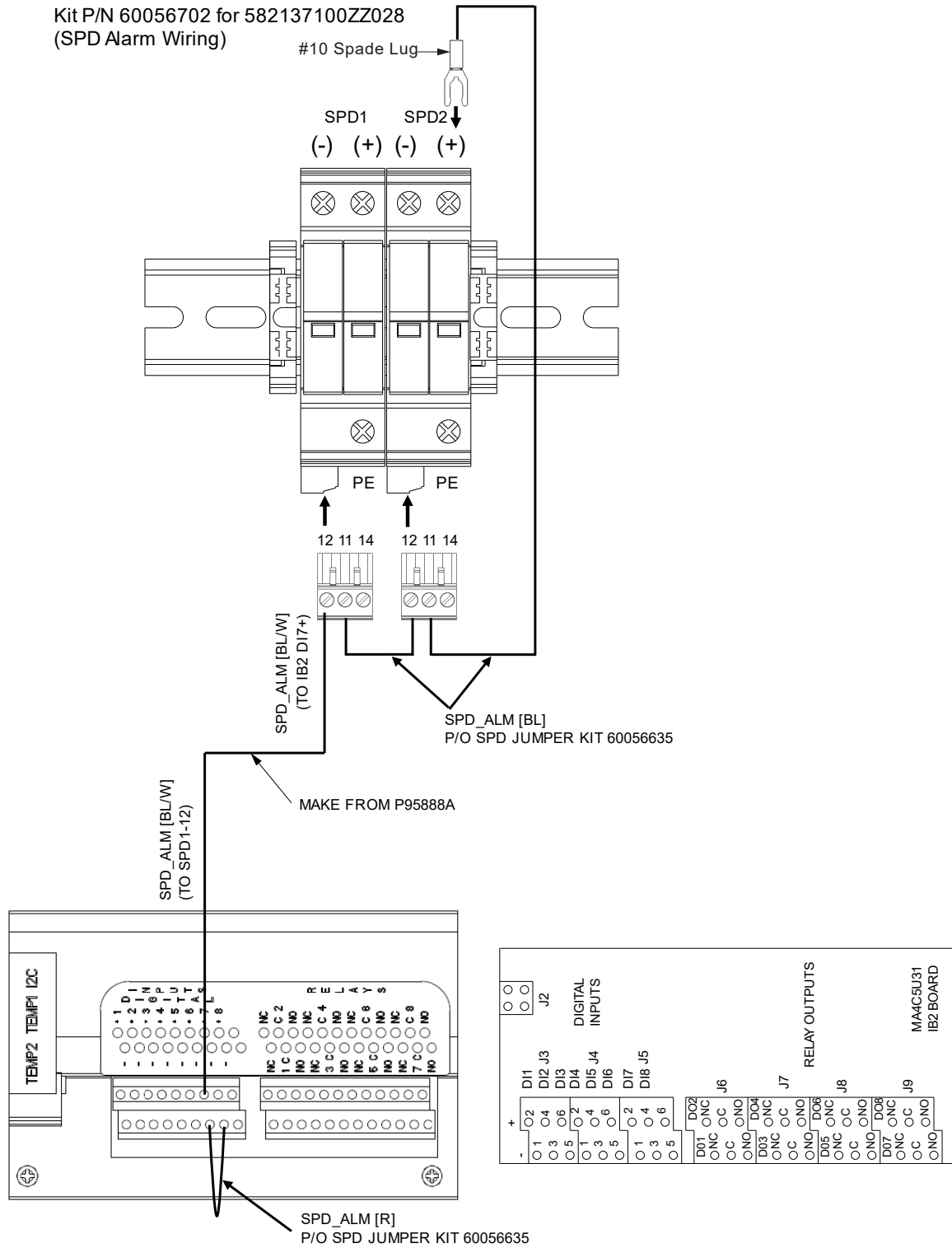
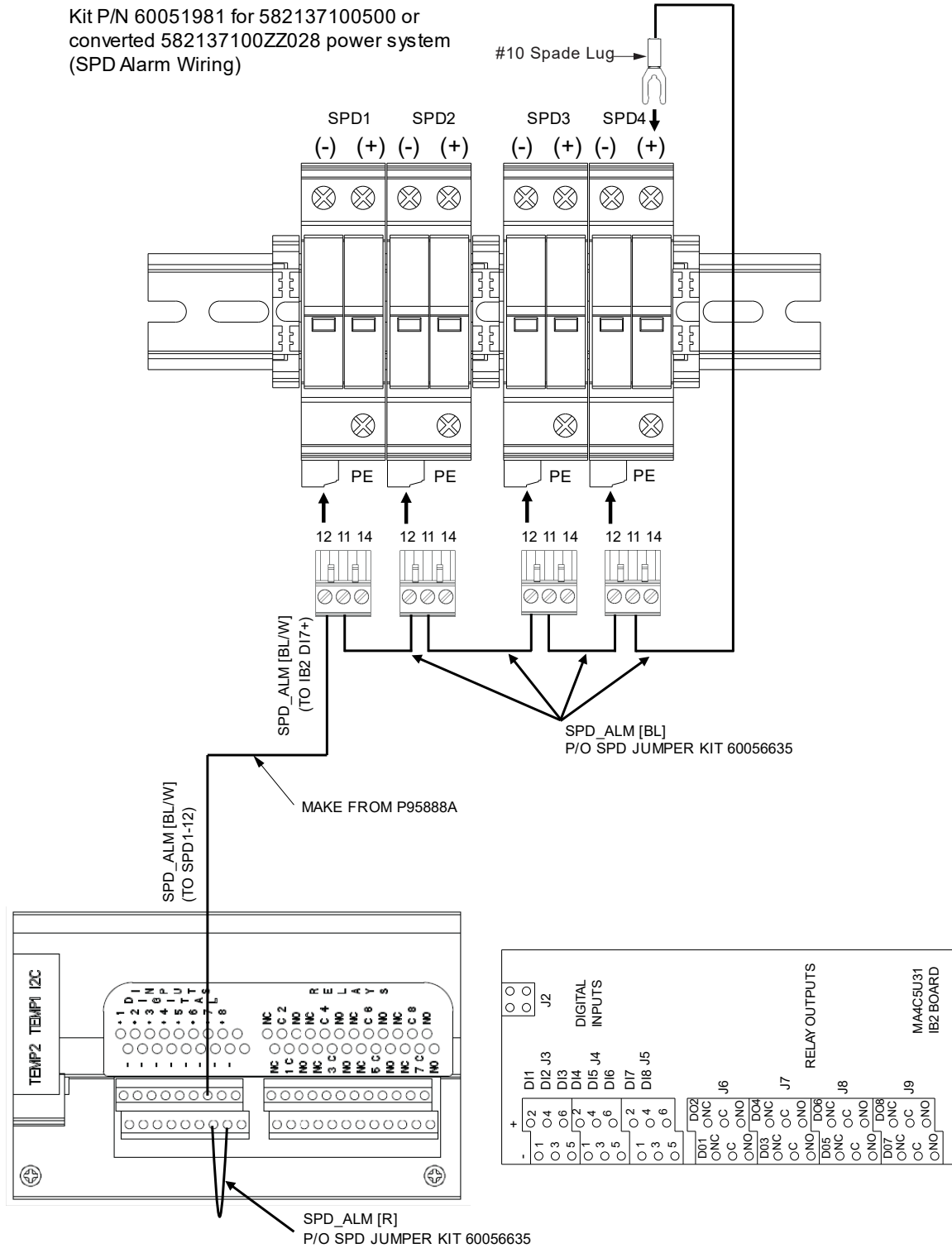


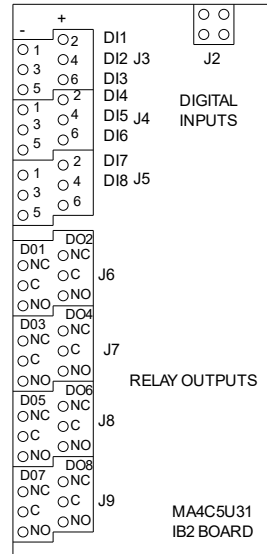
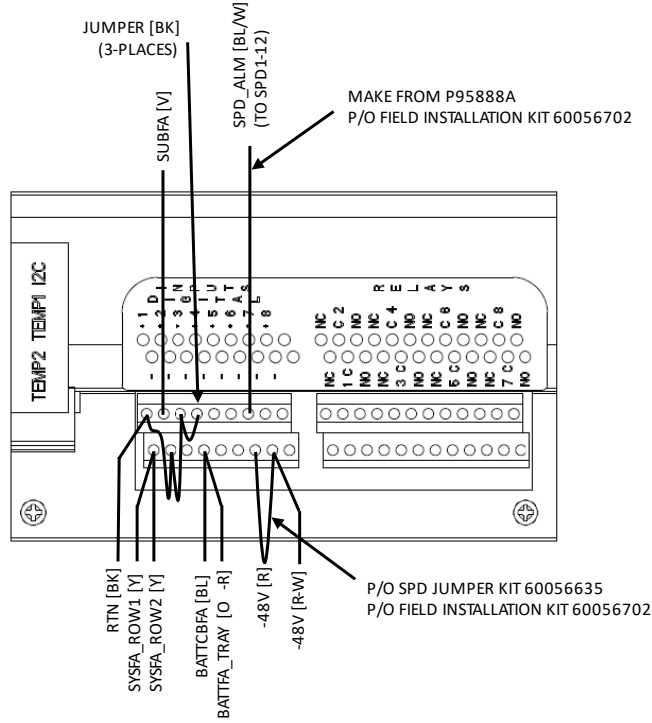
Figure 3.34 Connect SPD Alarm Contacts Wiring (cont'd from previous page)



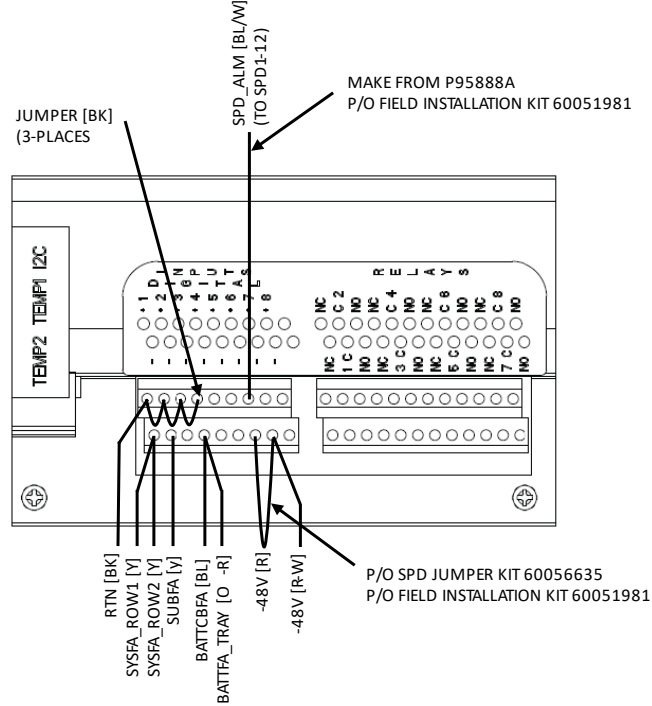
[ ] 9. Refer to Figure 3.35 for typical IB2 controller interface board alarm connections.

Figure 3.35 Typical IB2 Controller Interface Board Alarm Connections

582137100ZZ028 SPD ALARM WIRING



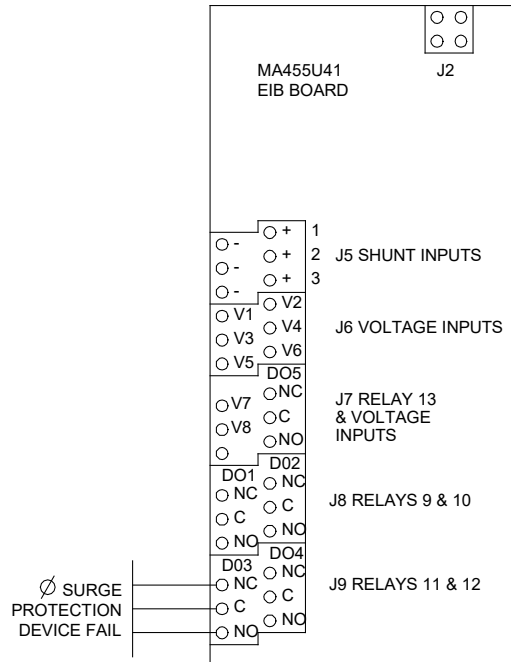
582137100500 SPD ALARM WIRING



- [ ] 10. Connect the EIB controller extended interface board to external surge protection device fail alarms as in Figure 3.36.

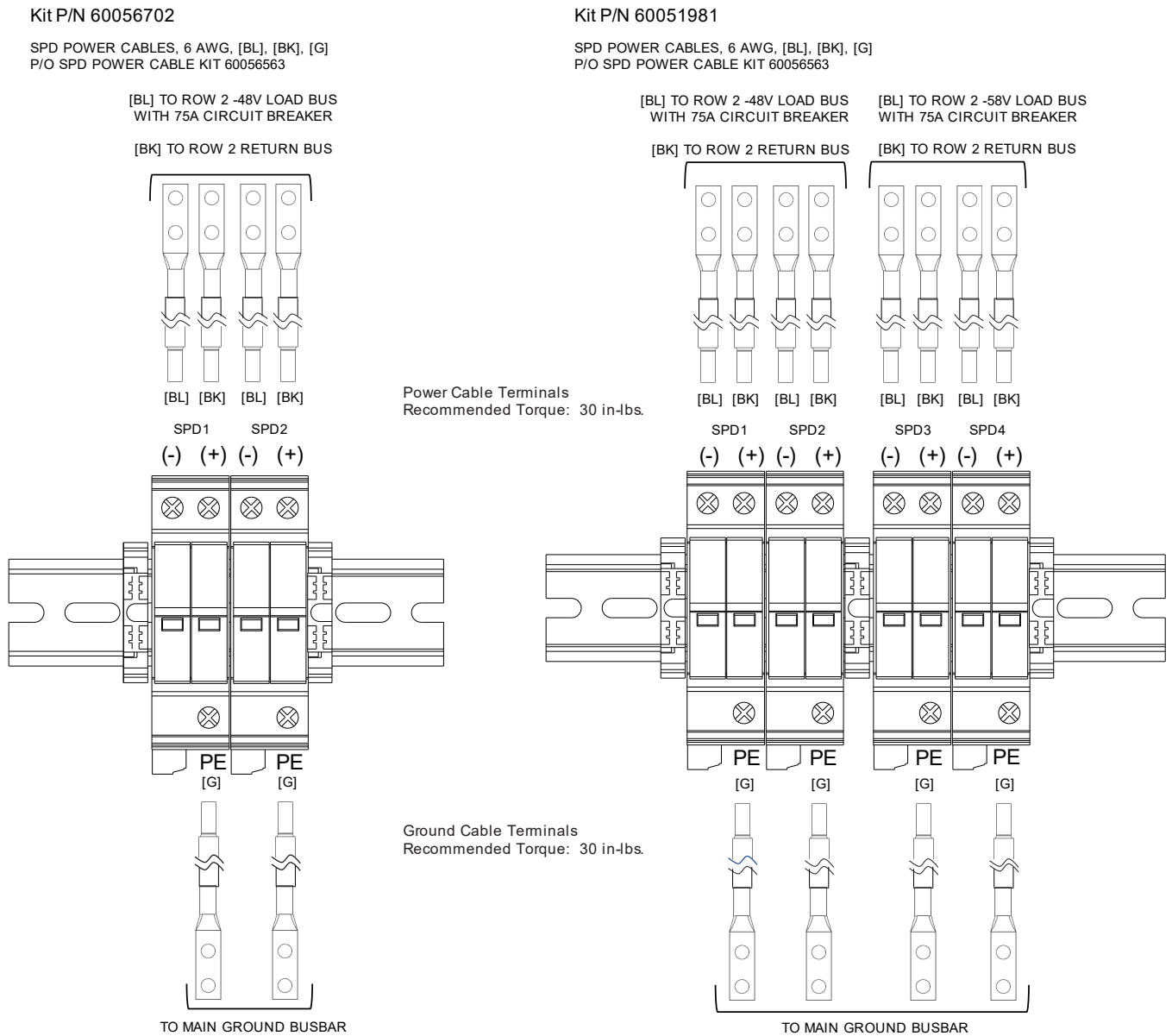
**Figure 3.36 Connect EIB Controller Extended Interface Board to External Surge Protection Device Fail Alarms**

Kit P/N 60056702 for 582137100ZZ028  
 Kit P/N 60051981 for 582137100500



- [ ] 11. Assemble the kit supplied 6 AWG SPD power and ground cables as follows. Refer to Figure 3.37.
  - a) Based on SPD mounting location, measure wire lengths from power system busbar to SPD. Cut the cable to length, strip 0.50" [12,7 mm] from the unterminated end, loosely assemble shrink tube (prior to 2-hole lug crimping), and crimp 2-hole lug onto the 6 AWG wire.
  - b) Apply heat to heat shrink tubing.
  - c) Assemble wire labels.
  - d) Repeat for each cable that needs assembled.

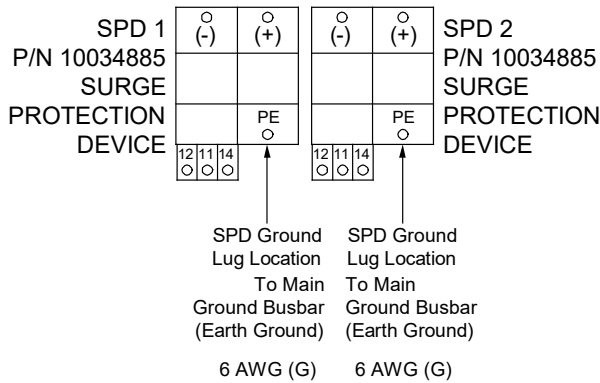
**Figure 3.37 Assemble Kit Supplied 6 AWG SPD Power and Ground Cables**



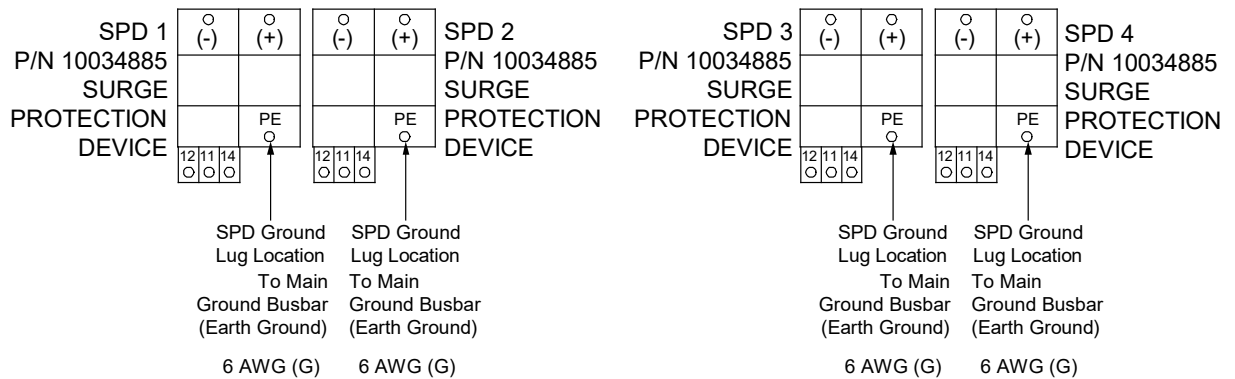
- [ ] 12. Connect each SPD device's PE terminal to the Main Ground Busbar (Earth Ground) using the previously assembled kit supplied cables as shown in Figure 3.38.
  - a) Assemble 2-hole lugs to the Main Ground Busbar (Earth Ground). Apply anti-oxidizing compound to busbar mating surfaces before assembling.
  - b) Assemble the other wire ends to the SPD as shown in Figure 3.38. The wire ends have factory-installed ferrules. Recommended torque is 30 in-lbs.

**Figure 3.38 Installing SPD Ground Cables to Earth Ground**

**Kit P/N 60056702 for 582137100ZZ028**



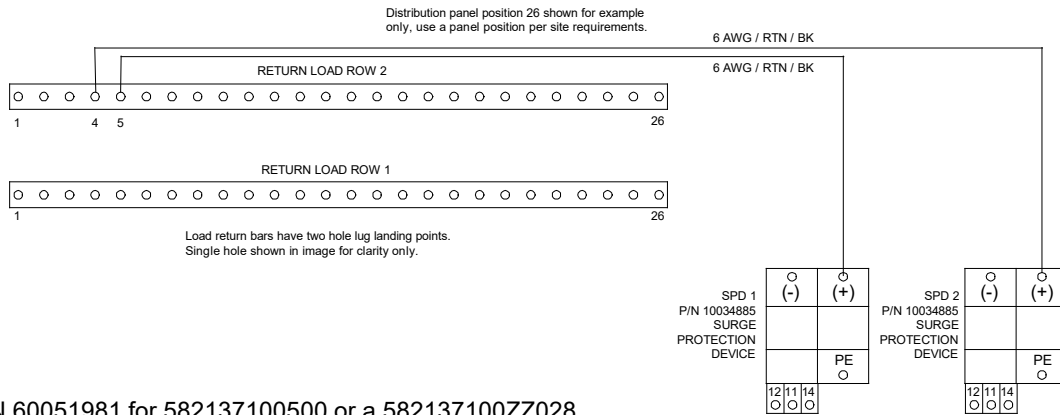
**Kit P/N 60051981 for 582137100500**



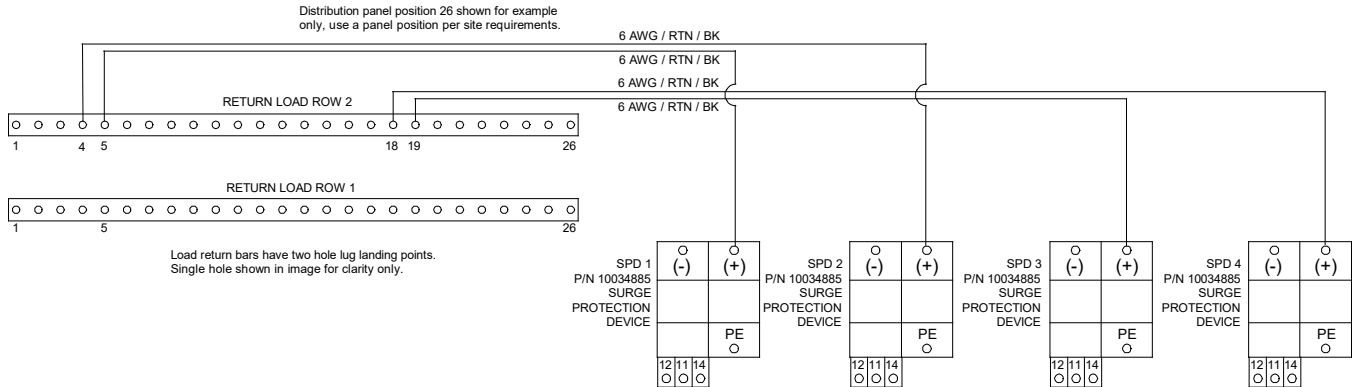
- [ ] 13. Connect each SPD device's (+) terminal to the power system's distribution load return bar using the previously assembled kit supplied cables as shown in Figure 3.39.
  - a) Assemble 2-hole lugs to power system load return busbar as shown in Figure 3.39. Apply anti-oxidizing compound to busbar mating surfaces before assembling. Recommended torque is 72 in-lbs using the kit supplied 1/4" flat washer, lock washers, and hex nuts.
  - b) Assemble the other wire ends to the SPD as shown in Figure 3.39. The wire ends have factory-installed ferrules. Recommended torque is 30 in-lbs.

**Figure 3.39 Installing SPD Power Cables to Return Bar**

**Kit P/N 60056702 for 582137100ZZ028**



**Kit P/N 60051981 for 582137100500 or a 582137100ZZ028 power system that has been converted**



- [ ] 14. For kit P/N 60056702, connect each SPD device's (-) terminal to the 75 A circuit breaker previously installed on the power system's -48 VDC distribution bus using the previously assembled kit supplied cables as shown in Figure 3.40.

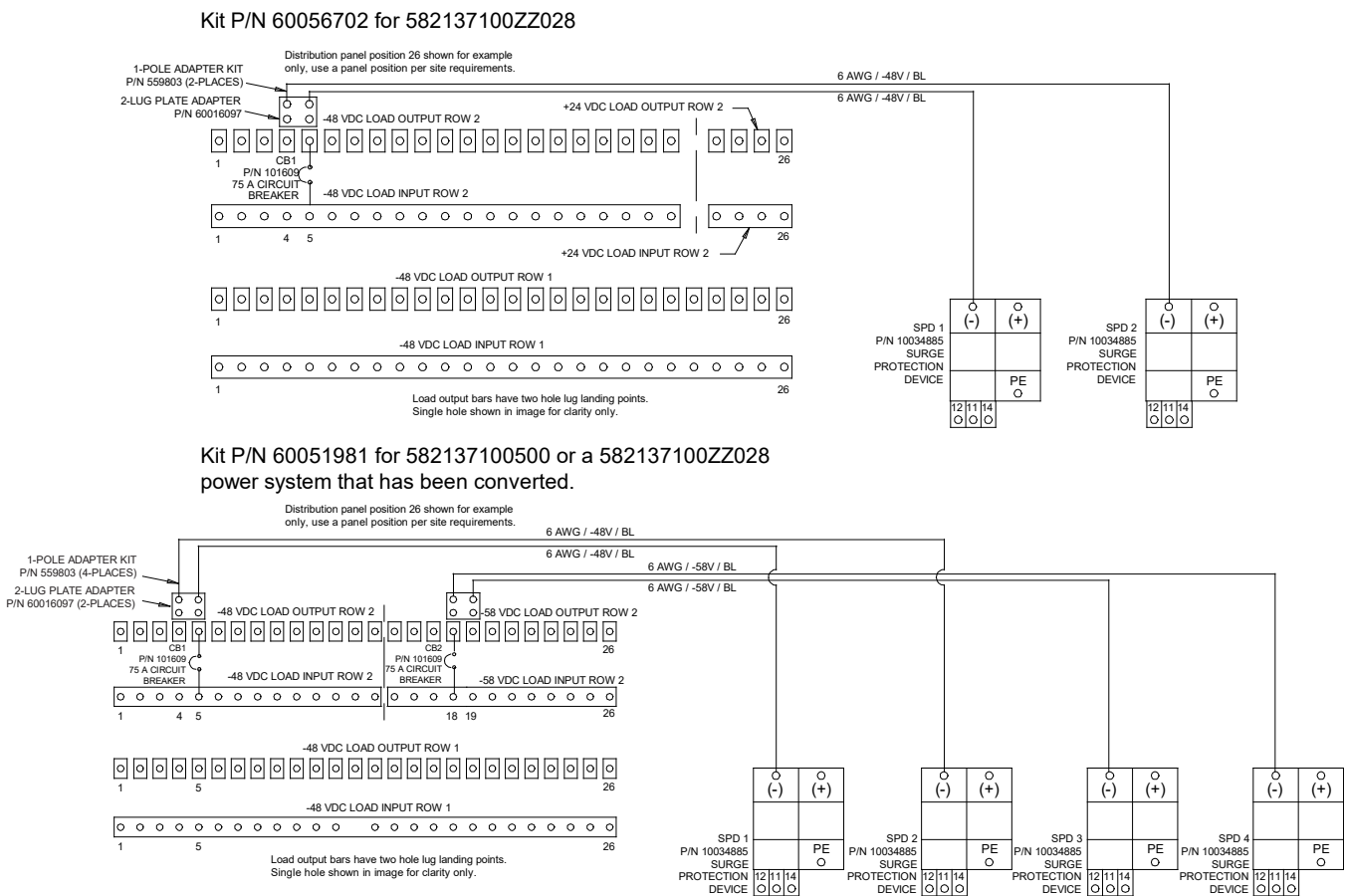
For kit P/N 60051981, connect two SPD device's (-) terminals to the 75 A circuit breaker previously installed on the power system's -48 VDC distribution bus and the remaining two SPD device's (-) terminals to the 75 A circuit breaker previously installed on the power system's -58 VDC distribution bus using the previously assembled kit supplied cables as shown in Figure 3.40.



**NOTE!** DO NOT intermix voltages. Be careful NOT TO run the -48V lead and -58V lead to the same circuit breaker.

- a) Assemble 2-hole lugs to power system bus bar as shown in Figure 3.40. Apply anti-oxidizing compound to busbar mating surfaces before assembling. Recommended torque is 72 in-lbs using the kit supplied 1/4" flat washer, lock washers, and hex nuts.
- b) Assemble the other wire ends to the SPD as shown in Figure 3.40. The wire ends have factory-installed ferrules. Recommended torque is 30 in-lbs.

**Figure 3.40** Installing SPD Power Cables to 75 A Circuit Breaker(s)



- [ ] 15. Dress and secure the installed cables with the kit supplied cable ties, as required.
- [ ] 16. Enable the external alarms or notify appropriate personnel that this procedure is finished.
- [ ] 17. Ensure that there are no local or remote alarms active on the system.



## 4 Setting Jumper and Switch Options

### 4.1 Circuit Cards with Jumpers and Switches in a List 20, 21, 25, 26, 27 Distribution Cabinet

Refer to Figure 4.1, Figure 4.2, and Figure 4.3.

Figure 4.1 Circuit Cards with Jumpers and Switches in a List 20, 25 Distribution Cabinet

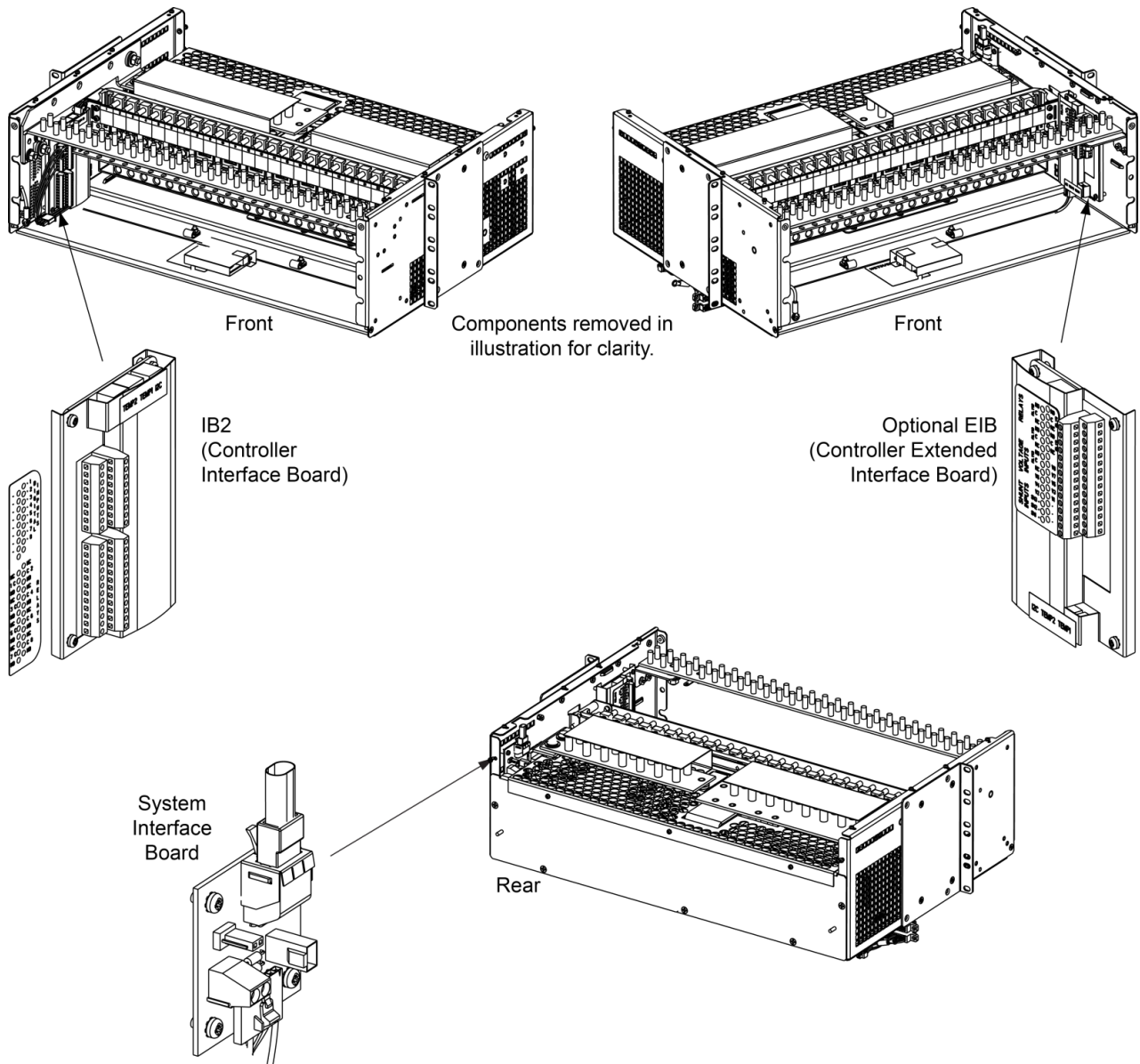


Figure 4.2 Circuit Cards with Jumpers and Switches in a List 21, 26 Distribution Cabinet

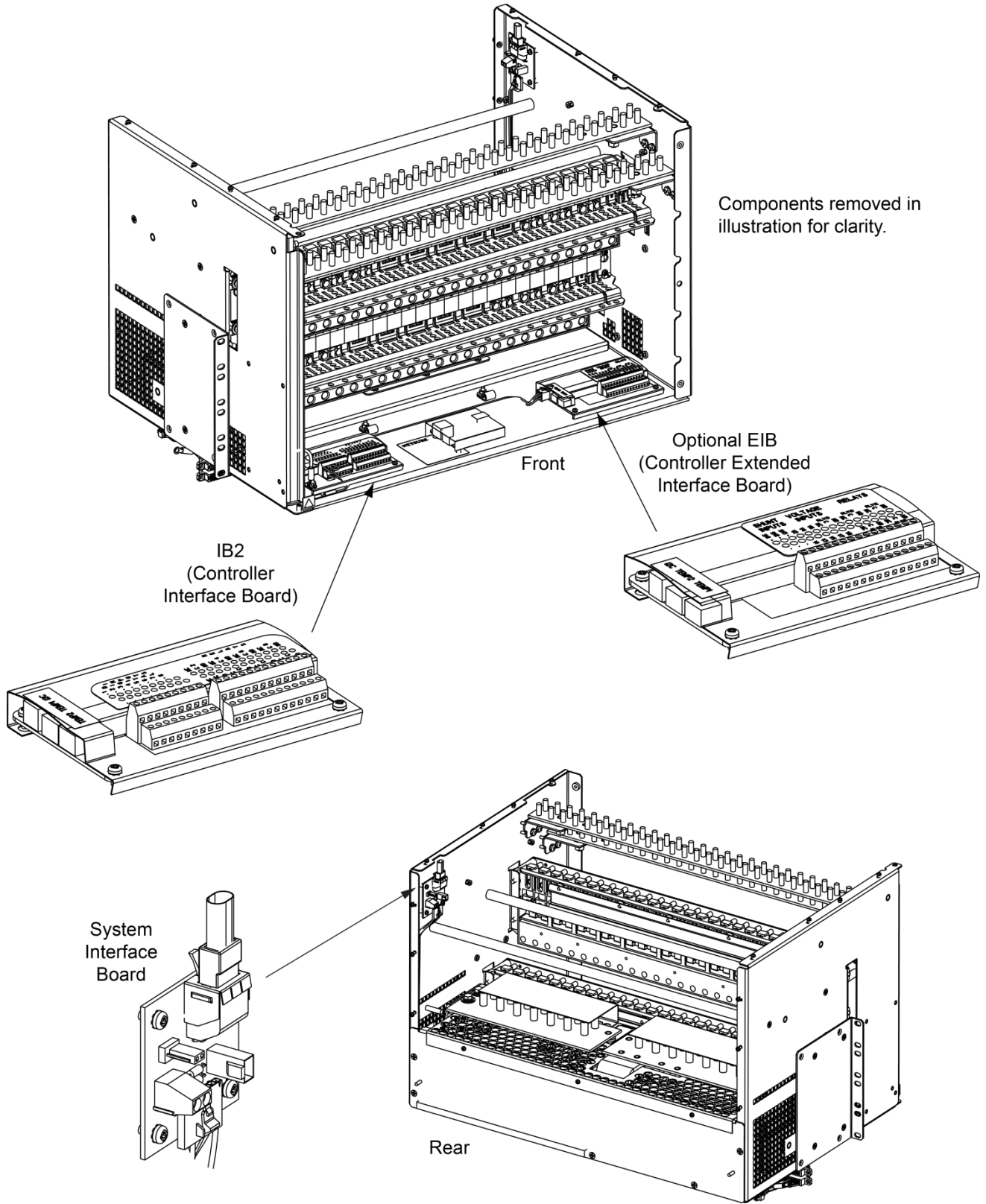
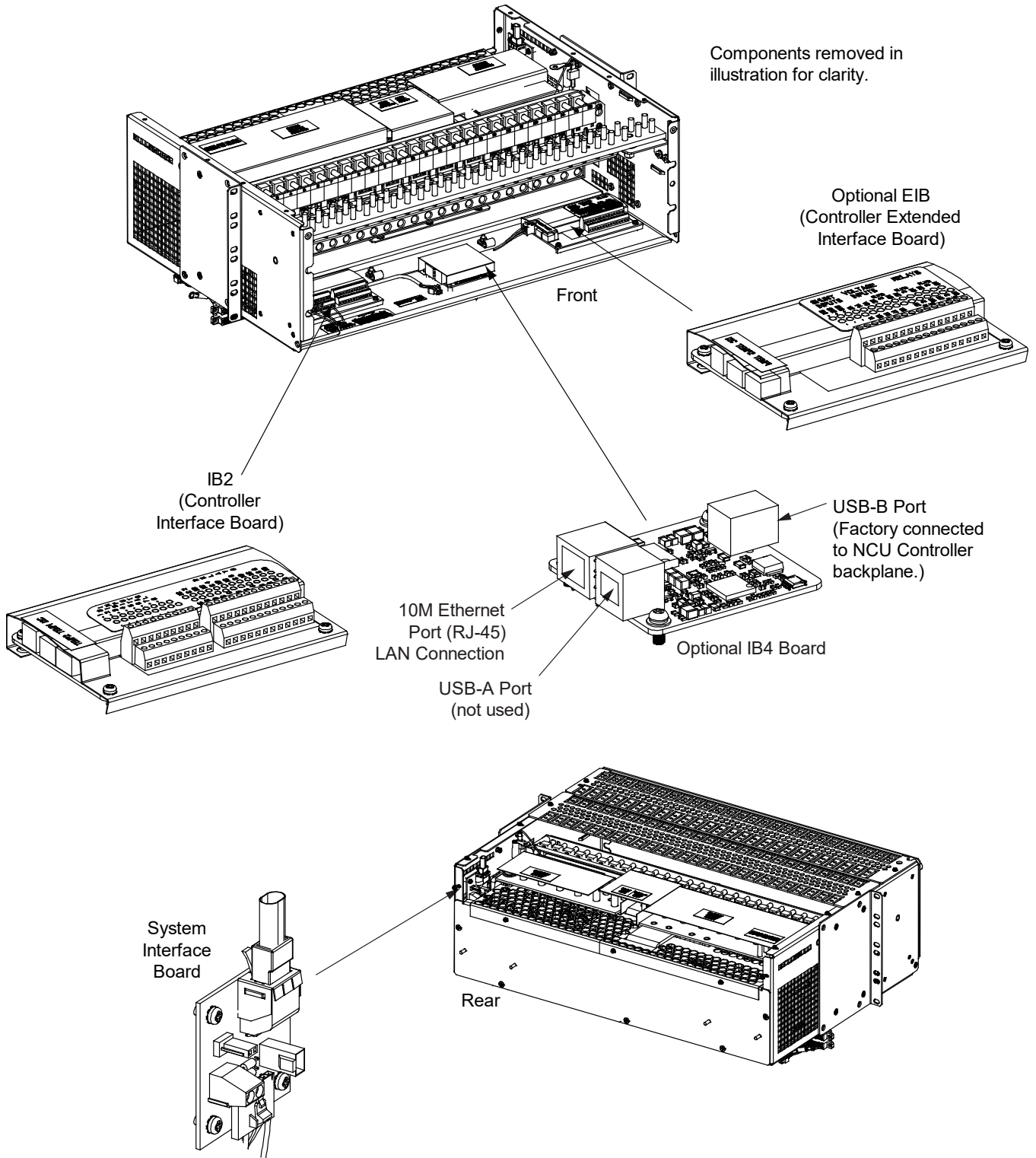


Figure 4.3 Circuit Cards with Jumpers and Switches in a List 27 Distribution Cabinet



## 4.2 Jumper Settings on the System Interface Circuit Card

Perform the following procedures to verify the factory settings and/or make the required settings per your site requirements. These procedures can also be used to make adjustments on a replacement circuit card.

### Controller Power Option

This option allows the controller to remain powered if a battery LVD is furnished and it opens. The controller is powered from the internal “system” bus. Rectifiers and battery are connected to this “system” bus, so the controller is powered both by the rectifiers and by the battery. A jumper option allows the controller to be powered from the “system side” of a battery LVD contactor (if furnished) or the “battery side” of a battery LVD contactor (if furnished). Refer to Figure 4.4 for circuit card location and jumper location.

- Jumper in “No Battery Power” Position: The controller is powered from the “system side” of a battery LVD contactor (if furnished). Note if a battery LVD contactor is not furnished, the controller is powered by both rectifiers and battery. If a battery LVD contactor is furnished and opens, the controller is powered by the rectifiers (if functional).

If you lose AC power and your BLVD opens, the controller will shut down.

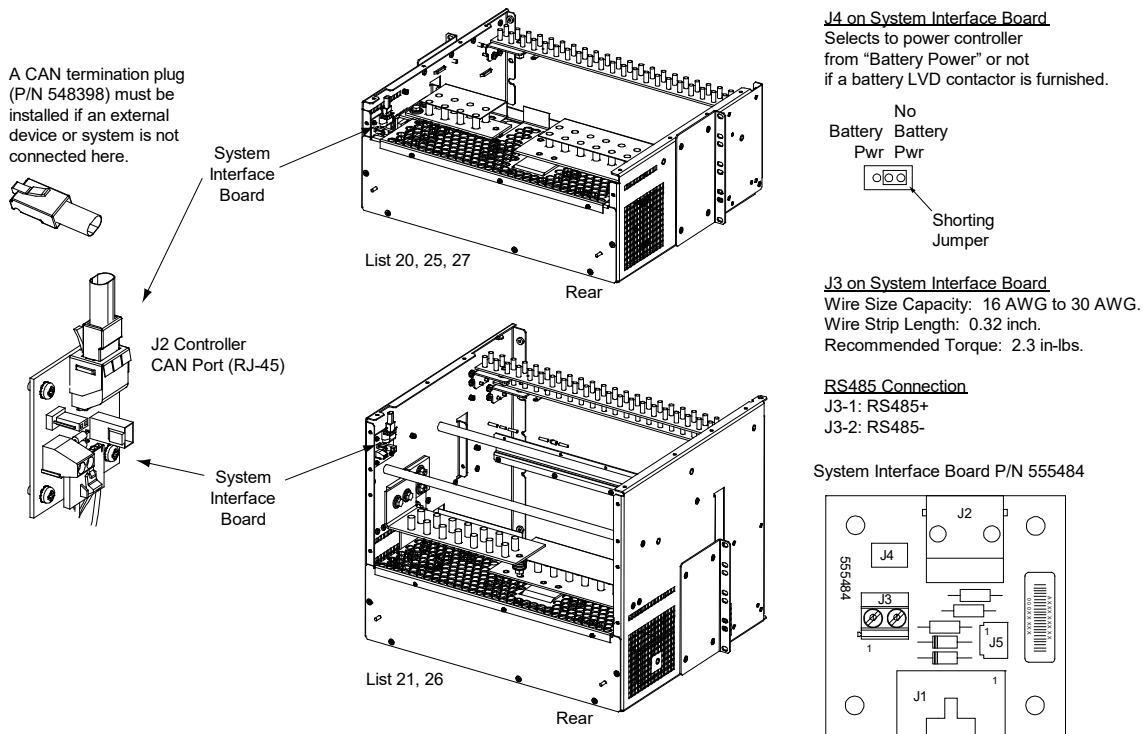
- Jumper in “Battery Power” Position: The controller is powered from the “battery side” of a battery LVD contactor (if furnished). Note if a battery LVD contactor is not furnished, the controller is powered by both rectifiers and battery. If a battery LVD contactor is furnished and opens, the controller is powered by the battery and the battery will drain. The controller’s power consumption is 5W.

If you lose AC power and your BLVD opens, the controller will continue to operate.

### Procedure

1. Refer to Figure 4.4 and place the jumper on J4 in the “Battery Pwr” or “No Battery Pwr” position.

**Figure 4.4 System Interface Board Jumper Location and Settings**



### 4.3 Switch Settings on the IB2 (Controller Interface Board)

Dip Switch SW1 on the IB2 board is used to set the communications address for this board. Refer to Table 4.1 for SW1 settings. Refer to Figure 4.1, Figure 4.2, and Figure 4.3 for circuit card location. Refer to Figure 4.5 for SW1 location.

Perform the following procedure to verify the factory settings.

This procedure can also be used to make adjustments on a replacement circuit card.

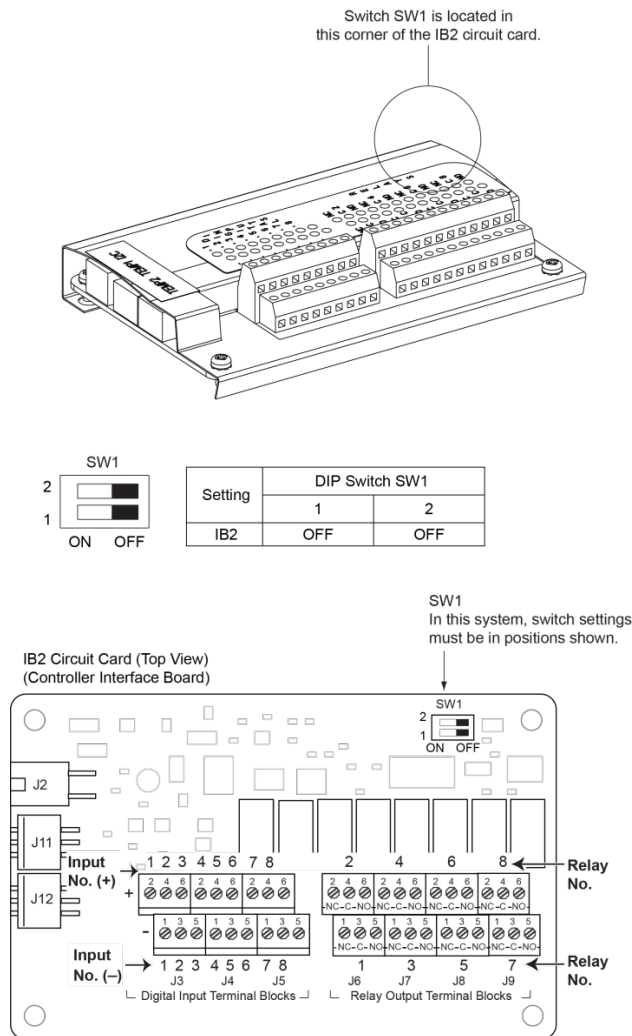
**Procedure**

1. Ensure SW1 is set per Table 4.1. Refer to Figure 4.5 for location.

**Table 4.1 IB2 Interface Board Switch Settings**

Setting	DIP Switch SW1	
	1	2
IB2	OFF	OFF

**Figure 4.5 IB2 Interface Board Switch Location and Settings**



## 4.4 Switch Settings on Optional EIB (Controller Extended Interface Board)

Dip Switch SW1 on the EIB board is used to set the communications address for this board. Refer to Table 4.2 for SW1 settings. Refer to Figure 4.1, Figure 4.2, and Figure 4.3 for circuit card location. Refer to Figure 4.6 for SW1 location.

Perform the following procedure to verify the factory settings.

This procedure can also be used to make adjustments on a replacement circuit card.

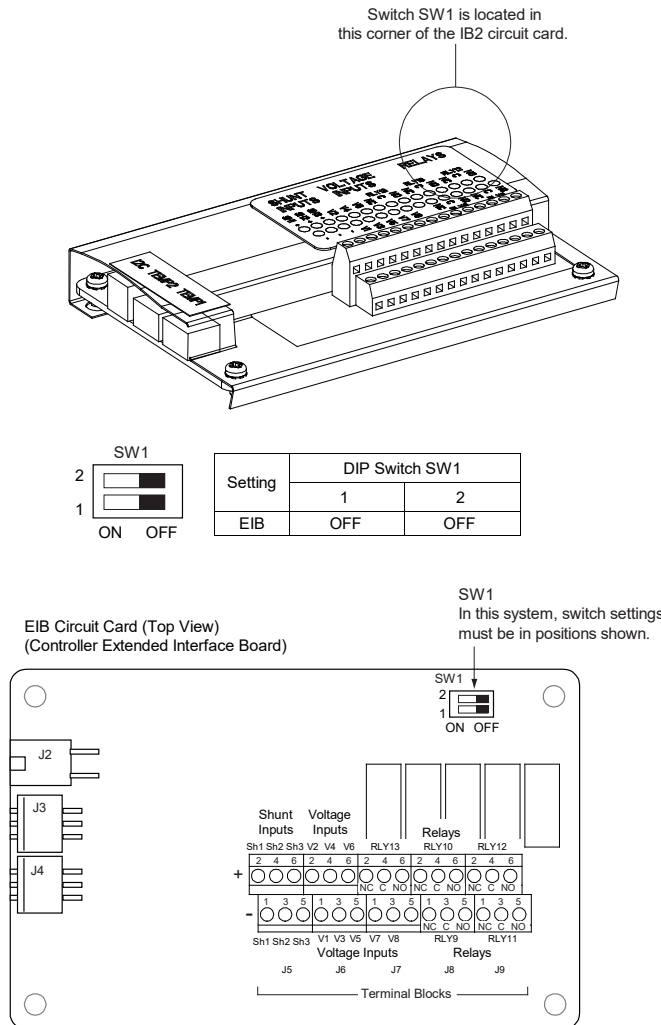
### Procedure

1. Ensure SW1 is set per Table 4.2. Refer to Figure 4.6 for location.

**Table 4.2 Optional EIB Extended Interface Board Switch Settings**

Setting	DIP Switch SW1	
	1	2
EIB	OFF	OFF

**Figure 4.6 Optional EIB Extended Interface Board Switch Location and Settings**



## 4.5 Switch Settings on the SM-DU (List 60 Hybrid Connection Cabinet)

The SM-DU is used in a List 60 Hybrid Connection Cabinet to monitor the internal circuit breaker shunts.

SM-DU uses three (3) 8-bit switches for parameter setting (S1, S2, and S3). Refer to Table 4.3 for switch settings. Refer to Figure 4.7 for switch locations.

Perform the following procedure to verify the factory settings. This procedure can also be used to make adjustments on a replacement circuit card.

### 4.5.1 Procedure

1. Ensure S1, S2, and S3 are set per Table 4.3. Refer to Figure 4.7 for location.

**Table 4.3 Switch Settings on the SM-DU (List 60 Hybrid Connection Cabinet) (cont'd on next page)**

DIP Switch S1								Description of Status
Communication Address			Shunt Voltage		Shunt Current			
1	2	3	4	5	6	7	8	
OFF	OFF	OFF	NA					Address 8#
OFF	OFF	ON						Address 1# <b>(Note 1)</b>
OFF	ON	OFF						Address 2#
OFF	ON	ON						Address 3#
ON	OFF	OFF						Address 4#
ON	OFF	ON						Address 5#
ON	ON	OFF						Address 6#
ON	ON	ON						Address 7#
NA								OFF
			OFF	ON	Shunt Voltage: 25 mV			
			ON	OFF	Shunt Voltage: 50 mV			
			ON	ON	Shunt Voltage: 60 mV			
NA					OFF	OFF	OFF	Shunt Current: 500 A <b>(Note 1)</b>
					OFF	OFF	ON	Shunt Current: 100 A
					OFF	ON	OFF	Shunt Current: 200 A
					OFF	ON	ON	Shunt Current: 300 A
					ON	OFF	OFF	Shunt Current: 400 A
					ON	OFF	ON	Shunt Current: 1000 A
					ON	ON	OFF	Shunt Current: 1500 A
					ON	ON	ON	Shunt Current: 2000 A

Note 1: Setting for this system.

**Table 4.3 Switch Settings on the SM-DU (List 60 Hybrid Connection Cabinet)**  
 (cont'd from previous page, cont'd on next page)

DIP Switch S2								Description of Status
Shunt 1 Setting		Shunt 2 Setting		Shunt 3 Setting		Shunt 4 Setting		
1	2	3	4	5	6	7	8	
OFF	OFF	NA				NA		Shunt 1 is Disabled
OFF	ON							Shunt 1 is Used for Battery
ON	OFF							Shunt 1 is Used for Load
ON	ON							Set via Software <b>(Note 1)</b>
NA		OFF	OFF	NA		NA		Shunt 2 is Disabled
		OFF	ON					Shunt 2 is Used for Battery
		ON	OFF					Shunt 2 is Used for Load
		ON	ON					Set via Software <b>(Note 1)</b>
NA				OFF	OFF	NA		Shunt 3 is Disabled
				OFF	ON			Shunt 3 is Used for Battery
				ON	OFF			Shunt 3 is Used for Load
				ON	ON			Set via Software <b>(Note 1)</b>
NA				OFF	OFF	NA		Shunt 4 is Disabled
				OFF	ON			Shunt 4 is Used for Battery
				ON	OFF			Shunt 4 is Used for Load
				ON	ON			Set via Software <b>(Note 1)</b>

Note 1: Setting for this system.

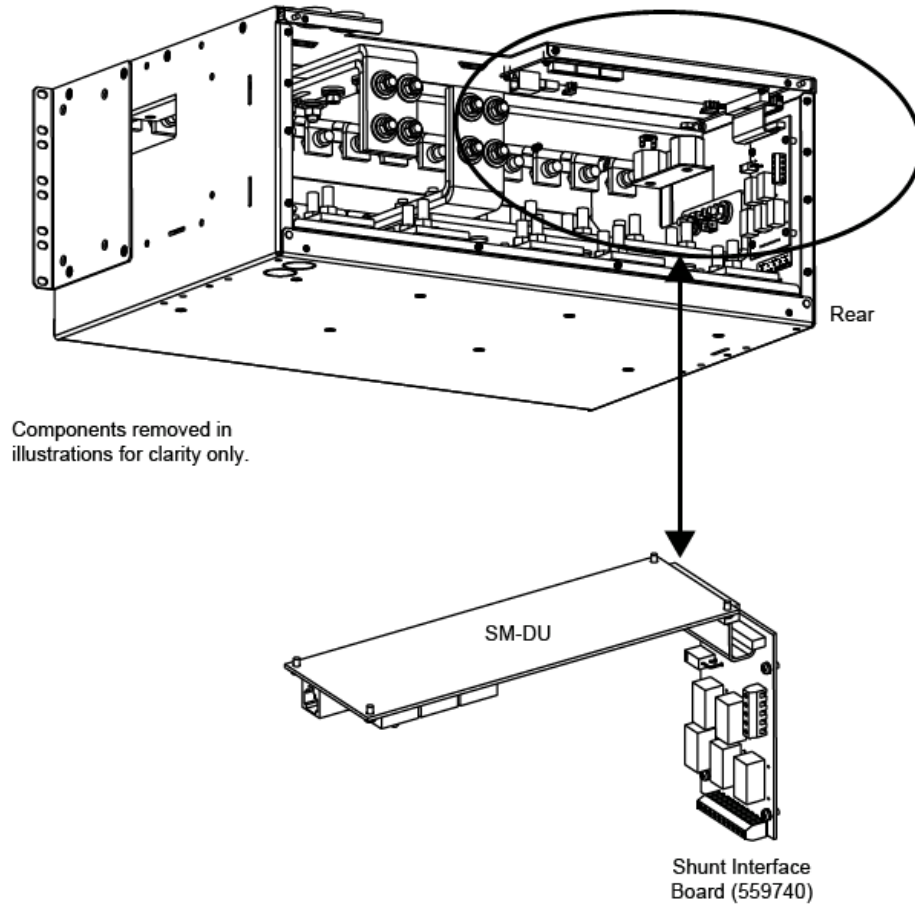


**Table 4.3 Switch Settings on the SM-DU (List 60 Hybrid Connection Cabinet) (cont'd from previous page)**

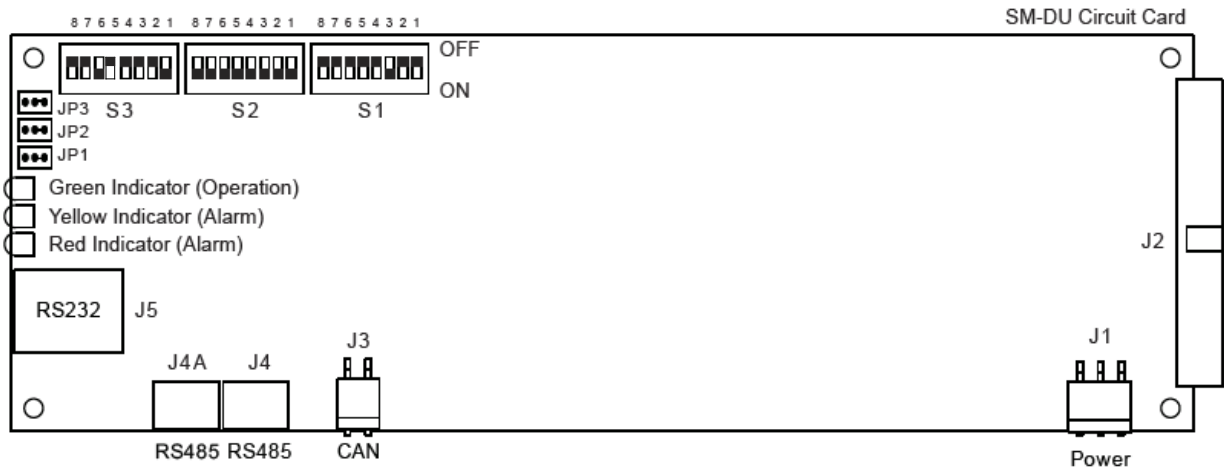
DIP Switch S3				
Set via Software	Contactor Type	Safe Mode	Dry Contact	Description of Status
1	2	3	4	
Off	NA			Shunt parameter is set through DIP switch.
On	NA			Shunt parameter is set via software. <b>(Note 1)</b>
NA	Off	NA		Bi-Stable Contactor <b>(Note 1)</b>
	On	NA		Mono-Stable Contactor
NA		Off	NA	LVD / reconnection is disabled upon communication failure. <b>(Note 1)</b>
		On		LVD / reconnection is enabled upon communication failure.
NA			On	LVD2 is a Dry Contact
			Off	LVD2 <b>(Note 1)</b>
DIP Switch S3				
Shunt 5 Setting		Reserved	Calibration Mode	Description of Status
5	6	7	8	
Off	Off	NA		Shunt 5 is Disabled
Off	On	NA		Shunt 5 is Used for Battery <b>(Note 1)</b>
On	Off	NA		Shunt 5 is Used for Load
On	On	NA		Shunt 5 is Set via Software
NA			Off	Operation Mode <b>(Note 1)</b>
			On	Calibration Mode

Note 1: Setting for this system.

**Figure 4.7 SM-DU Switch Location and Settings (List 60 Hybrid Connection Cabinet)**



Note: Factory switch settings shown.



## 5 Making Electrical Connections

### 5.1 Important Safety Instructions



**DANGER!** Adhere to the “Important Safety Instructions” starting on page vii.

### 5.2 Wiring Considerations

All wiring and branch circuit protection should follow the current edition of the American National Standards Institute (ANSI) approved National Fire Protection Association's (NFPA) National Electrical Code (NEC), and applicable local codes. For operation in countries where the NEC is not recognized, follow applicable codes.

For wire size, branch circuit protection, crimp lug, and general wiring recommendations; refer to System Application Guide SAG582137100 and Power Data Sheet PD588705300.

Lugs should be crimped per lug manufacturer's specifications.

Refer to Table 5.1 for supplemental lug crimping information when using the special application crimp lug / strap combination.

**Table 5.1 Supplemental Lug Crimping Information when Using the Special Application Crimp Lug / Strap Combination**

Crimp Lug Part No.		Crimp Tool Required <sup>1</sup> , T&B Model TBM12 or TBM15 Hydraulic Heads		
		Color Key	Die Index/ Code No.	Die Cat. Number
245393500	Burndy: YA25L-4TCG1	Pink	42H	15508
245393600	Burndy: YA26L-4TCG1	Black	45	15526
245393700	Burndy: YA27L-4TCG1	Orange	50	15530
245393800	Burndy: YA28L-4TCG1	Purple	54H	15511
514872	T & B: 256-30695-1879	Yellow	62	15510
	Burndy: YA29L-4TCG1			
514873	T & B: 256-30695-1880	Red	71	15514
	Burndy: YA31L-4TCG1			

<sup>1</sup> The lugs should be crimped to the specifications given in the manufacturer's instructions furnished with the crimp tool or lug.

### 5.3 Relay Rack / Equipment Cabinet Frame Grounding Connection

For relay rack / equipment cabinet frame grounding requirements, refer to the current edition of the American National Standards Institute (ANSI) approved National Fire Protection Association's (NFPA) National Electrical Code (NEC), applicable local codes, and your specific site requirements.

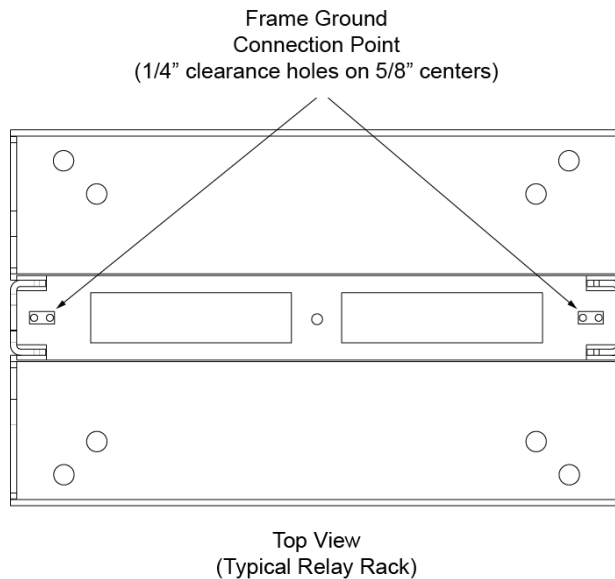
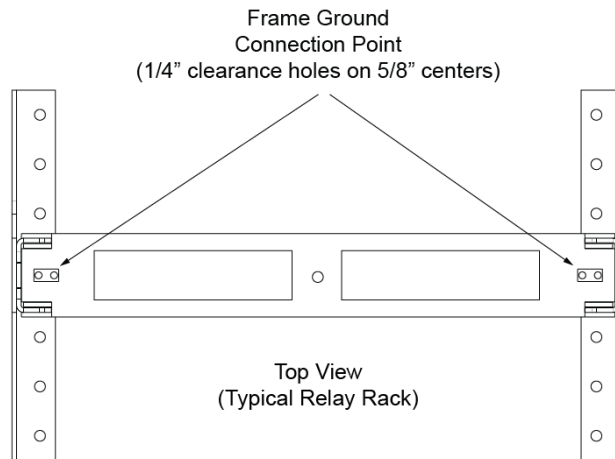
Attach a customer grounding network lead to the equipment mounting rack per site requirements. Holes are provided on the top of each relay rack for installing a lead with a two-hole lug that has 1/4" bolt clearance holes on 5/8" centers. When using 1/4-inch hardware, recommended torque is 84 in-lbs. when a standard flat washer and lock washer are used. Refer to Figure 5.1 for locations.

**NOTE!** REMOVE TAPE FROM HOLE LOCATIONS BEFORE INSTALLING LUG.

**NOTE!** The DC return connection to this system can remain isolated from system frame and chassis (DC-I).

**NOTE!** This system is suitable for installation as part of the Common Bonding Network (CBN).

**Figure 5.1** Relay Rack Frame Grounding Connection Points



## 5.4 Power System Shelf Frame Grounding Requirements

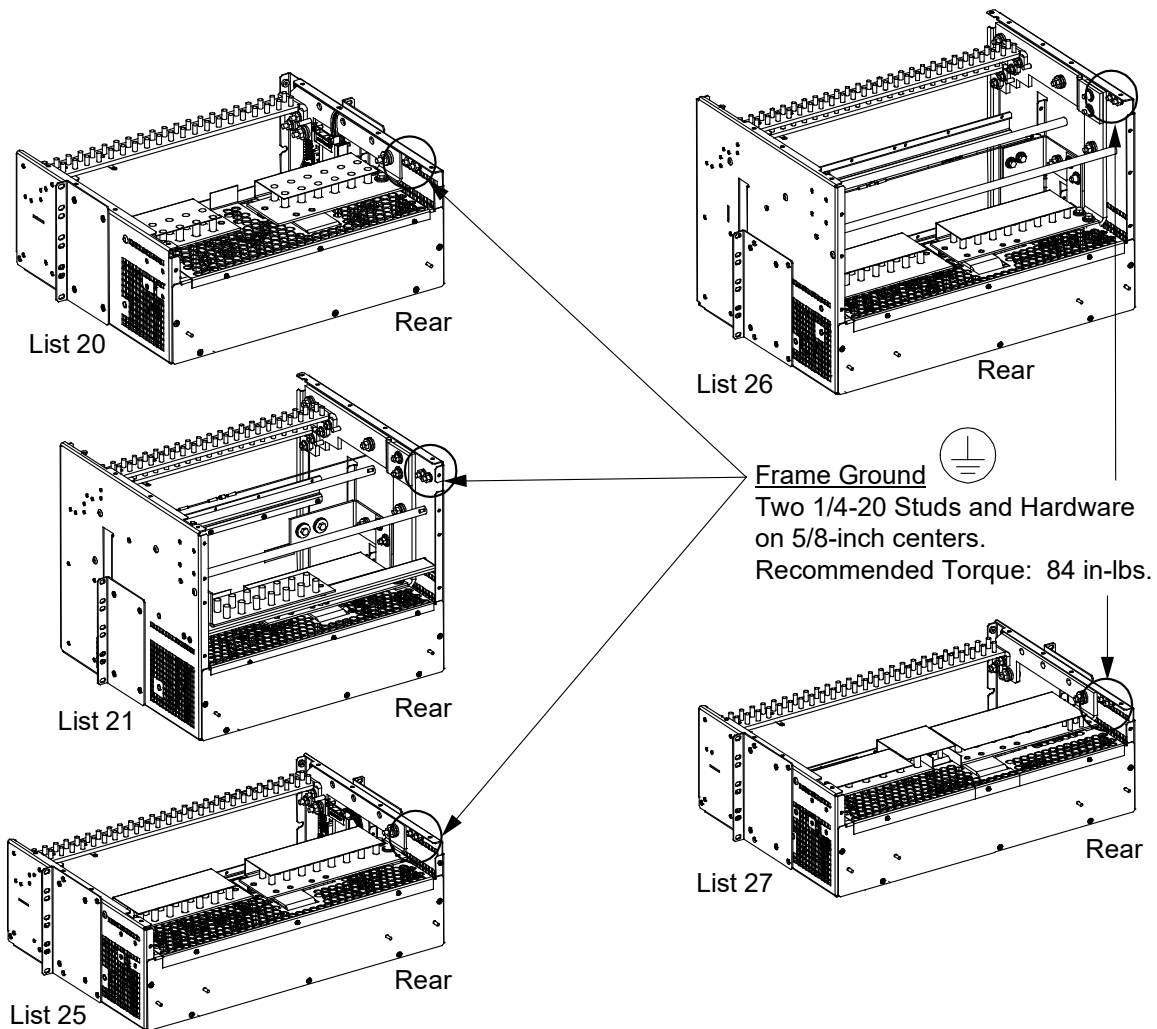
For power system shelf frame grounding requirements, refer to the current edition of the American National Standards Institute (ANSI) approved National Fire Protection Association's (NFPA) National Electrical Code (NEC), applicable local codes, and your specific site requirements.

The frame grounding connection to the power system shelf is made by using grounding washers with the mounting hardware used to secure the shelf to the relay rack or equipment cabinet. Refer to "Mounting the System in a Relay Rack or an Equipment Rack" on page 10. Ensure that the relay rack or equipment cabinet is properly grounded.

One set of frame grounding studs are also provided on the rear of the power system shelf. This provides for the installation of a lead with a two-hole lug that has 1/4" bolt clearance holes on 5/8" centers. Connect a frame grounding lead to the studs as required. Refer to Figure 5.2 for location and recommended torque for this connection.

Recommended frame ground wire size is 6 AWG.

**Figure 5.2 Power System Shelf Frame Ground Connection**



## **5.5 Assemblies Comprising the Power System Frame Grounding Connection**

The module mounting assemblies have M4 frame ground studs located on the rear panel. Refer to PD588705300 for location.

List 40, List 45, and List 46 have 10-32 grounding studs located on the assembly. Refer to Figure 5.3, Figure 5.4, and Figure 5.5 for location.

## **5.6 Central Office Ground Connection**

Landing points are provided on the battery return bus for a central office ground lead (see Figure 5.65, Figure 5.66, Figure 5.70, Figure 5.71, or Figure 5.75). For central office grounding requirements, refer to the current edition of the American National Standards Institute (ANSI) approved National Fire Protection Association's (NFPA) National Electrical Code (NEC), applicable local codes, and your specific site requirements.

## 5.7 Rectifier Nominal 120 VAC / 208 VAC / 240 VAC Input and AC Input Equipment Grounding Connections



**DANGER!** Adhere to the “Important Safety Instructions” starting on page vii.

### 5.7.1 Wiring Considerations

For wire size, branch circuit protection, crimp lug, and general wiring recommendations; refer to System Application Guide SAG582137100 and Power Data Sheet PD588705300.

### 5.7.2 To 19” or 23” Rectifier AC Input / Solar Converter DC Input Panel (List 40, 45) and 23” Rectifier AC Input Panel (List 46)

The Rectifier AC Input / Solar Converter DC Input Panel or Rectifier AC Input Panel provides circular openings at the sides for rectifier AC input and grounding conductors. The openings accept 1.25 inch conduit fittings. It is recommended that AC input wiring be provided to all rectifier mounting positions, including currently unused positions. This wiring will ease future installation of rectifiers to meet increased load requirements.



**NOTE!** A grounding conductor must be provided with each conduit.

Refer to Figure 5.3, Figure 5.4, and Figure 5.5 for connection details and recommended torque.

#### **Procedure**

1. Remove the rear cover.
2. Install conduit fittings as required in the sides of the Rectifier AC Input / Solar Converter DC Input Panel or Rectifier AC Input Panel. Plug buttons are provided and must be installed in the openings not being used.
3. Route wiring into the Rectifier AC Input / Solar Converter DC Input Panel or Rectifier AC Input Panel through the previously installed conduit fittings.
4. Make input connections as shown in Figure 5.3, Figure 5.4, and Figure 5.5. Connect each wire by inserting the stripped end into the wire opening, and then tightening the screw. Torque connections to value shown in the appropriate illustration.



**NOTE!** Terminal blocks for a system with maximum possible rectifier and/or solar converter modules shown. Your system may have less terminal blocks than shown.



**NOTE!** Make equipment grounding connections to earth ground, *not* to the branch circuit neutral conductor.

5. Connect equipment grounding leads to the frame ground studs using installer-provided ring lugs and factory-supplied mounting hardware. Torque connections to value shown in the appropriate illustration.
6. After all input and equipment grounding connections have been made and checked, reinstall the rear cover.
7. Locate the module position identification label either on the inside of the distribution cabinet door (rack mounted systems) or inside the OSP cabinet when no door is furnished. As the system is being wired for module inputs, write the type of module to be placed in each module mounting position in the space provided on the label. Write R for rectifier, C for converter, and S for solar converter. See Figure 5.6.



**NOTE!** For systems with List 46 and -48 VDC to +24 VDC converters or -48 VDC to -58 VDC converters are being used (List 26 two row distribution panel or List 27 single row distribution panel) in the plant, the following module restrictions apply for factory installed shelves 2 through 5:

- Rectifiers can be in any or all six (6) positions if three (3) AC inputs provided.
- +24V or -58V converters can be in the right three (3) positions (positions 4, 5 and 6).
- Rectifiers can be in any position which has AC power that is not taken up with a converter.
- One (1) Solar converter can be installed in the shelf, position 1 or 2.
- Three (3) solar converters can be installed in the shelf, positions 1 or 2, positions 3 or 4 and positions 5 or 6 if the -48V to +24V or -48V to -58V bus bar is not installed to the shelf above.



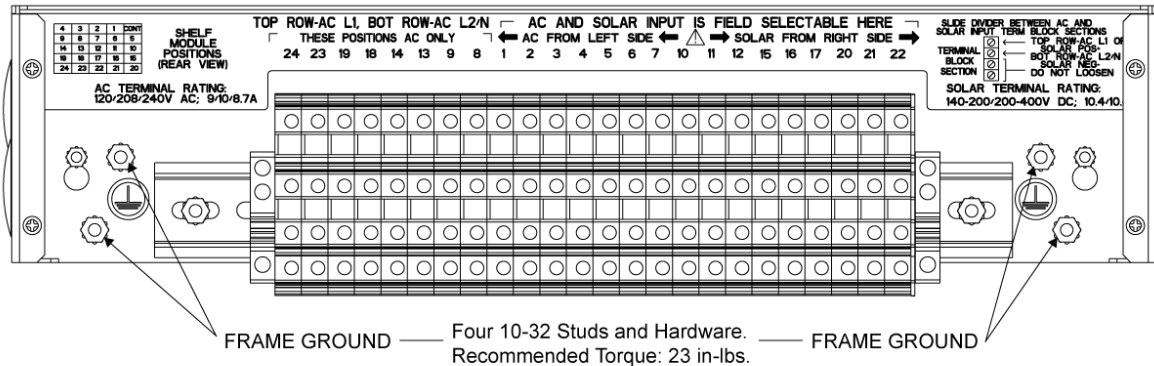
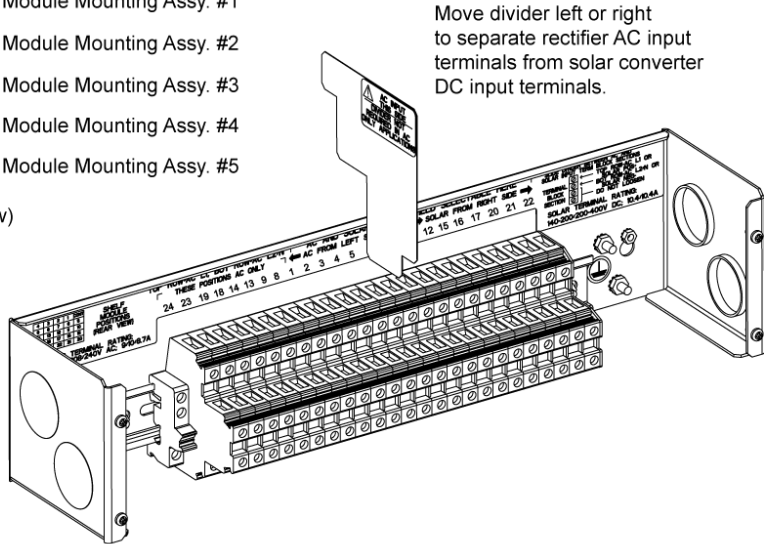
**Figure 5.3 Rectifier AC Input Connections to Rectifier AC Input / Solar Converter DC Input Panel (List 40)**  
 (Nominal 120 VAC / 208 VAC / 240 VAC, Single Phase, 50 Hz / 60 Hz)

AC INPUT CONNECTIONS (582137100 List 40)  
 1 FEED PER 1 RECTIFIER, SINGLE PHASE

4	3	2	1	Controller
9	8	7	6	Module Mounting Assy. #1
14	13	12	11	Module Mounting Assy. #2
19	18	17	16	Module Mounting Assy. #3
24	23	22	21	Module Mounting Assy. #4
			20	Module Mounting Assy. #5

Rectifier Module Mounting Slots (Rear View)

Note:  
 Wiring to a field installed module mounting assembly is done at the rear of the module mounting assembly.



L1  
 RECTIFIER AC INPUT FEED  
 1 FEED PER 1 RECTIFIER  
 120 VAC / 208 VAC / 240 VAC,  
 50 Hz / 60 Hz, SINGLE PHASE

L2 / N

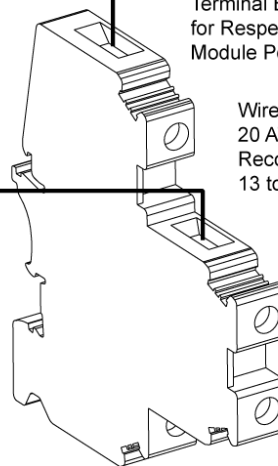
Terminal Block  
 for Respective  
 Module Position

Wire Size Capacity:  
 20 AWG to 6 AWG.  
 Recommended Torque:  
 13 to 16 in-lbs.

**ALERT!**  
 ENSURE PROPER VOLTAGE  
 (AC OR DC) IS CONNECTED  
 TO EACH MODULE MOUNTING  
 POSITION.

Line to Line:  
 Connect Line 1 to L1.  
 Connect Line 2 to L2.

Line to Neutral  
 Connect Line to L1.  
 Connect Neutral to N.



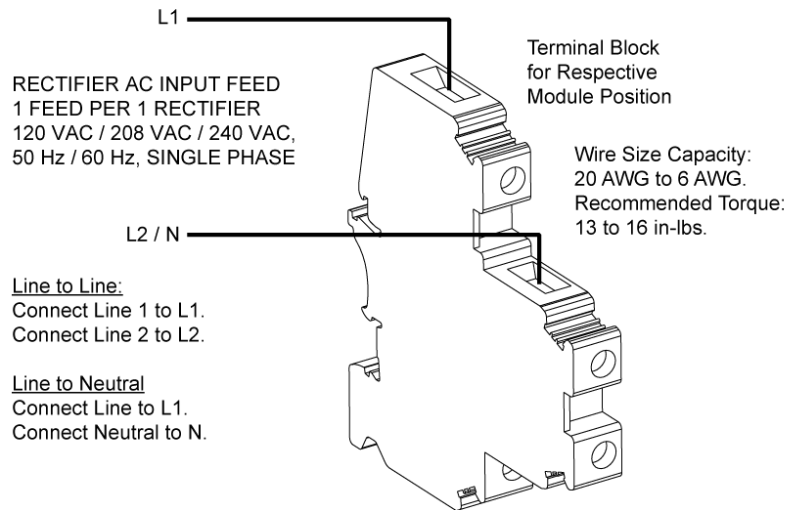
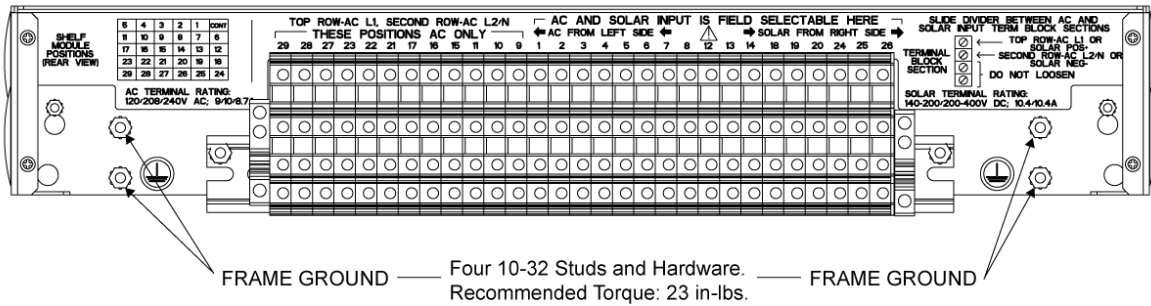
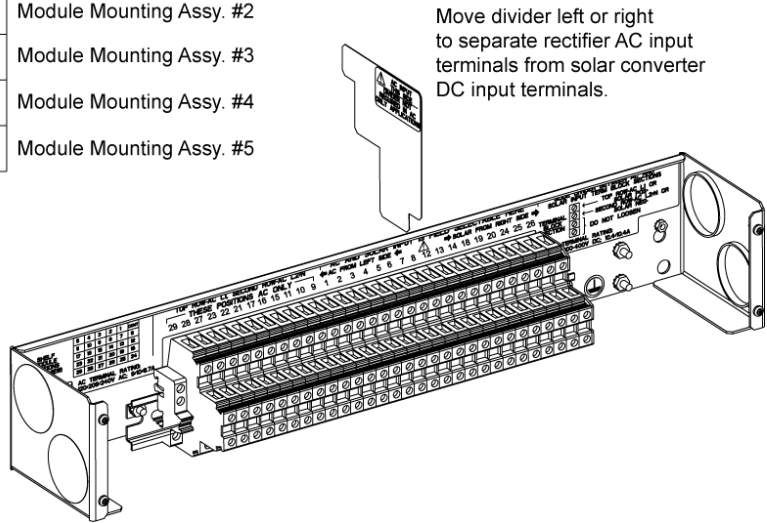
**Figure 5.4 Rectifier AC Input Connections to Rectifier AC Input / Solar Converter DC Input Panel (List 45)**  
 (Nominal 120 VAC / 208 VAC / 240 VAC, Single Phase, 50 Hz / 60 Hz)

AC INPUT CONNECTIONS (582137100 List 45)  
 1 FEED PER 1 RECTIFIER, SINGLE PHASE

5	4	3	2	1	Controller	Module Mounting Assy. #1
11	10	9	8	7	6	Module Mounting Assy. #2
17	16	15	14	13	12	Module Mounting Assy. #3
23	22	21	20	19	18	Module Mounting Assy. #4
29	28	27	26	25	24	Module Mounting Assy. #5

Rectifier Module Mounting Slots (Rear View)

Note:  
 Wiring to a field installed module mounting assembly is done at the rear of the module mounting assembly.



**ALERT!**  
 ENSURE PROPER VOLTAGE  
 (AC OR DC) IS CONNECTED  
 TO EACH MODULE MOUNTING  
 POSITION.

Line to Line:  
 Connect Line 1 to L1.  
 Connect Line 2 to L2.

Line to Neutral  
 Connect Line to L1.  
 Connect Neutral to N.

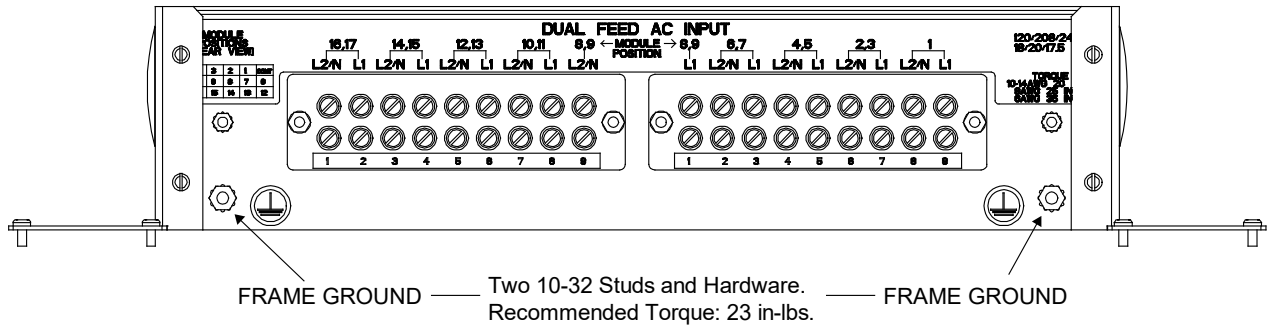
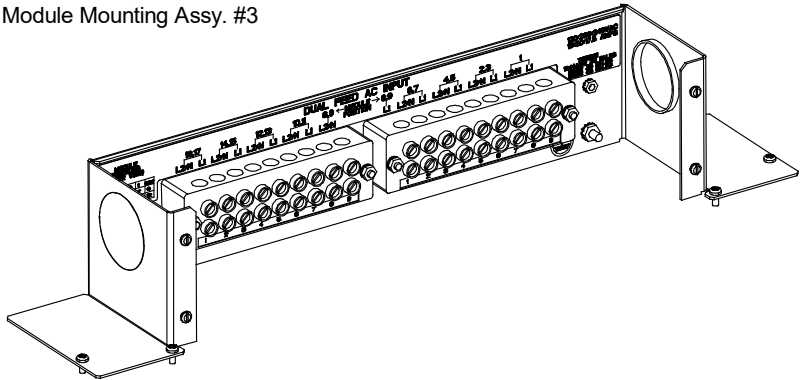
**Figure 5.5 Rectifier AC Input Connections to Rectifier AC Input Panel (List 46)**  
 (Nominal 120 VAC / 208 VAC / 240 VAC, Single Phase, 50 Hz / 60 Hz)

**AC INPUT CONNECTIONS (582137100 List 46)**  
**1 FEED PER 2 RECTIFIERS, SINGLE PHASE**

5	4	3	2	1	Controller	Module Mounting Assy. #1
11	10	9	8	7	6	Module Mounting Assy. #2
17	16	15	14	13	12	Module Mounting Assy. #3

Rectifier Module Mounting Slots (Rear View)

Note:  
 Wiring to a field installed module mounting assembly is done at the rear of the module mounting assembly.

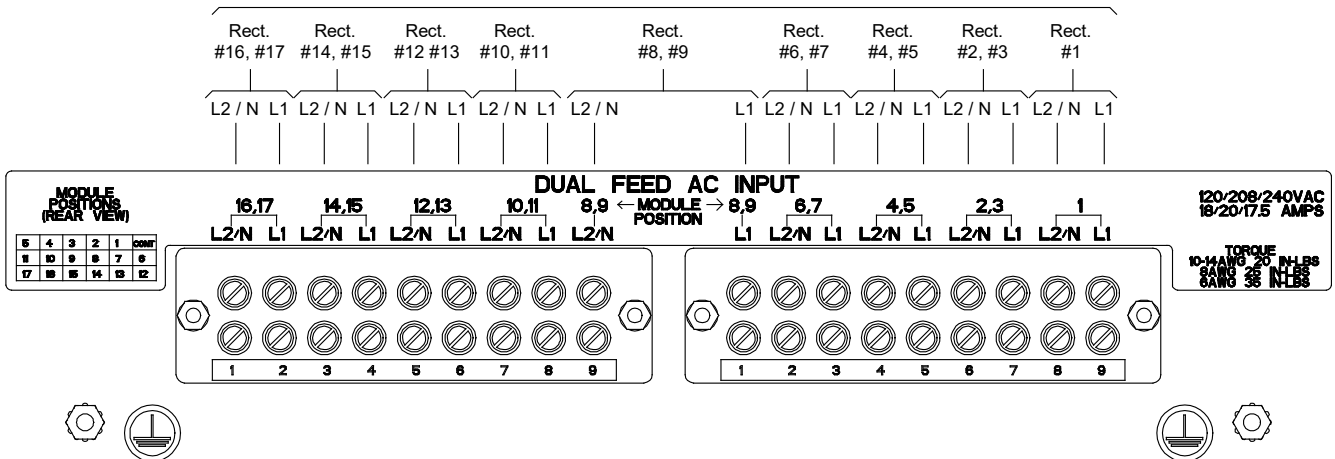


Line to Line:  
 Connect Line 1 to L1.  
 Connect Line 2 to L2.

Line to Neutral:  
 Connect Line to L1.  
 Connect Neutral to N.

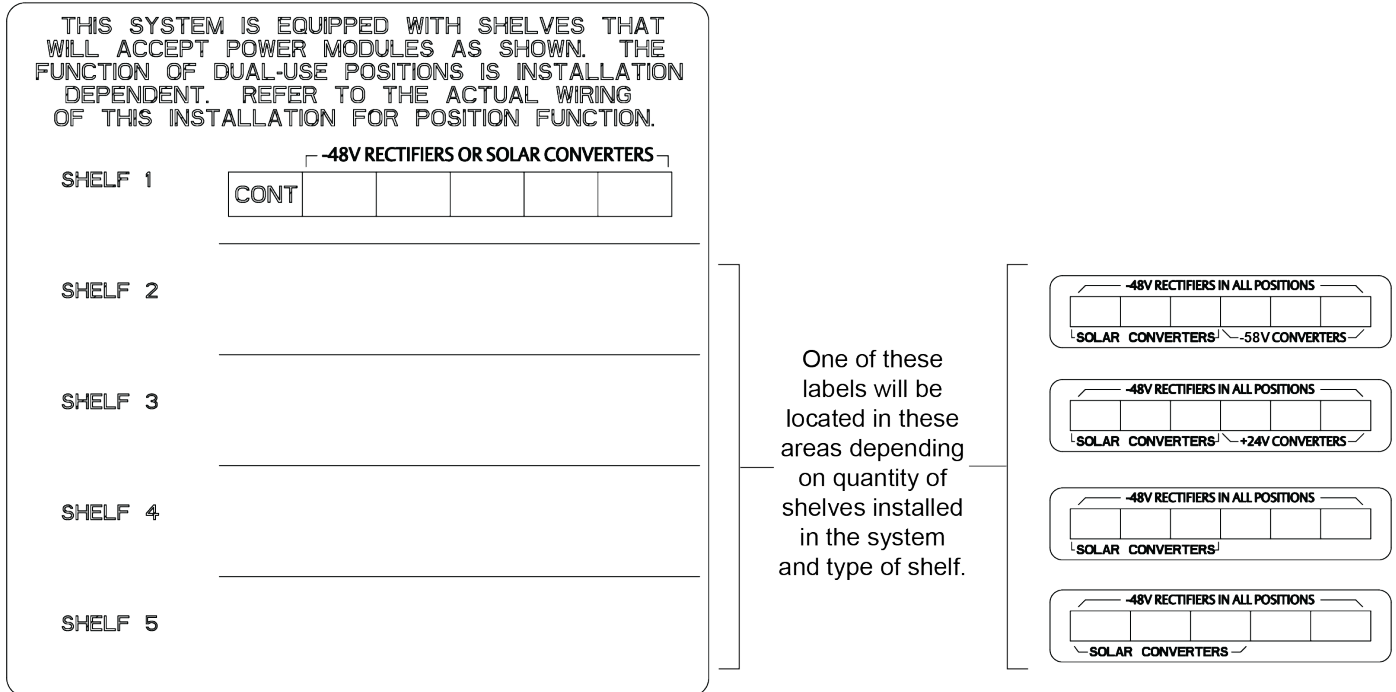
**RECTIFIER AC INPUT FEEDS**  
**1 FEED PER 2 RECTIFIERS**  
**120 VAC / 208 VAC / 240 VAC,**  
**50 Hz / 60 Hz, SINGLE PHASE**

**Wire Size Capacity and Torque:**  
 10 AWG to 14 AWG; 20 in-lbs.  
 8 AWG; 25 in-lbs.  
 6 AWG; 35 in-lbs.



**Figure 5.6 Module Position Identification Label**

The label depicted below is located either on the inside of the distribution cabinet door (rack mounted systems) or inside the OSP cabinet when no door is furnished. As the system is being wired for module inputs, write the type of module to be placed in each module mounting position in the space provided on the label. Write R for rectifier, C for converter, and S for solar converter.



### 5.7.3 To Individual Module Mounting Assembly(s) Equipped with Molex Connectors and Provided with Rectifier AC Input Cable Assemblies or Rectifier AC Input Line Cords

Spec. No. 588705300 module mounting assembly(s) may be equipped with plug-in input connectors located on the rear of the assembly. Input cable assemblies and line cords with mating connectors are available (see Power Data Sheet PD588705300). Refer to Power Data Sheet PD588705300 for connection details.

Locate the module position identification label either on the inside of the distribution cabinet door (rack mounted systems) or inside the OSP cabinet when no door is furnished. As the system is being wired for module inputs, write the type of module to be placed in each module mounting position in the space provided on the label. Write R for rectifier, C for converter, and S for solar converter. See Figure 5.6.

For systems using Molex connected cords and -48 VDC to +24 VDC converters or -48 VDC to -58 VDC converters are being used (List 26 two row distribution panel or List 27 single row distribution panel) in the plant, the following module restrictions apply for factory installed shelves 2 through 5:

- Rectifiers can be in any or all six (6) positions if three (3) AC inputs provided.
- +24V or -58V converters can be in the right three (3) positions (positions 4, 5 and 6).
- Rectifiers can be in any position which has AC power that is not taken up with a converter.
- One (1) Solar converter can be installed in the shelf, position 1 or 2.
- Three (3) solar converters can be installed in the shelf, positions 1 or 2, positions 3 or 4 and positions 5 or 6 if the -48V to +24V or -48V to -58V bus bar is not installed to the shelf above.

## 5.8 Solar Converter 140 VDC to 200 VDC / 200 VDC to 400 VDC Input Connections



**DANGER!** Adhere to the “Important Safety Instructions” starting on page vii.

### 5.8.1 Wiring Considerations

For wire size, branch circuit protection, crimp lug, and general wiring recommendations; refer to System Application Guide SAG582137100 and Power Data Sheet PD588705300.

### 5.8.2 To 19” or 23” Rectifier AC Input / Solar Converter DC Input Panel (List 40, 45)

The Rectifier AC Input / Solar Converter DC Input Panel provide circular openings at the top for solar converter DC input and grounding conductors. The openings accept 1.25 inch conduit fittings. It is recommended that DC input wiring be provided to all solar converter mounting positions, including currently unused positions. This wiring will ease future installation of solar converters to meet increased load requirements.

Refer to Figure 5.7 and Figure 5.8 for connection details and recommended torque.

#### **Procedure**

1. Remove the rear cover.
2. Install conduit fittings as required in the sides of the Rectifier AC Input / Solar Converter DC Input Panel. Plug buttons are provided, and must be installed in the openings not being used.
3. Route wiring into the Rectifier AC Input / Solar Converter DC Input Panel through the previously installed conduit fittings.
4. Make input connections as shown in Figure 5.7 or Figure 5.8. Connect each wire by inserting the stripped end into the wire opening, and then tightening the screw. Torque connections to value shown in the appropriate illustration.



**NOTE!** Some of the module mounting slots cannot be wired for solar converters, as indicated in Figure 5.7 and Figure 5.8.



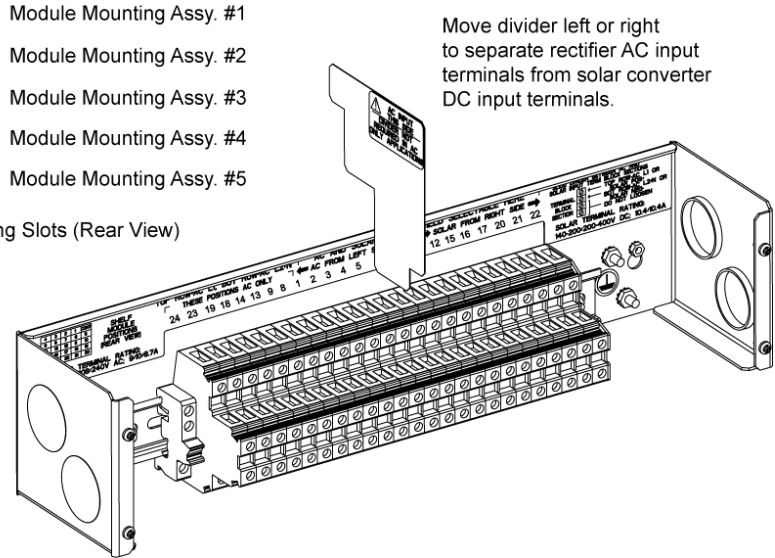
**NOTE!** Terminal blocks for a system with maximum possible rectifier and/or solar converter modules shown. Your system may have less terminal blocks than shown.

5. Connect equipment grounding leads to the frame ground studs using installer-provided ring lugs and factory-supplied mounting hardware. Torque connections to value shown in the appropriate illustration.
6. After all input and equipment grounding connections have been made and checked, reinstall the rear cover.
7. Locate the module position identification label either on the inside of the distribution cabinet door (rack mounted systems) or inside the OSP cabinet when no door is furnished. As the system is being wired for module inputs, write the type of module to be placed in each module mounting position in the space provided on the label. Write R for rectifier, C for converter, and S for solar converter. See Figure 5.6.

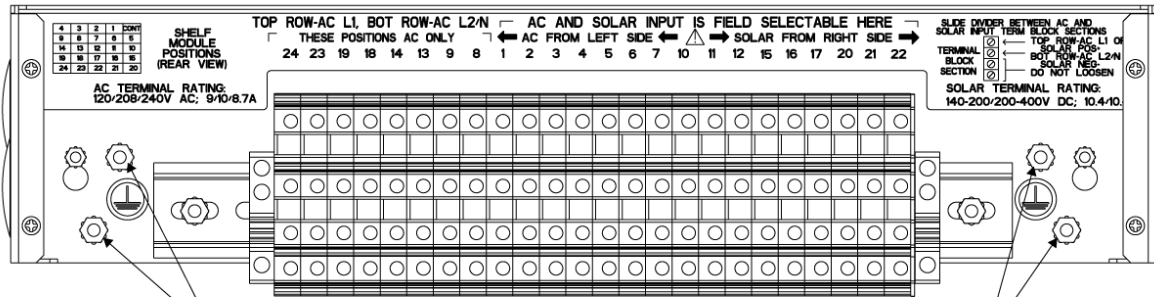
**Figure 5.7 Solar Converter DC Input Connections to Rectifier AC Input / Solar Converter DC Input Panel (List 40) (140 VDC to 200 VDC / 200 VDC to 400 VDC)**

**DC INPUT CONNECTIONS (582137100 List 40)  
1 FEED PER 1 SOLAR CONVERTER**

4	3	2	1	Controller
9	8	7	6	5
14	13	12	11	10
19	18	17	16	15
24	23	22	21	20



Note:  
Wiring to a field installed module mounting assembly is done at the rear of the module mounting assembly.



FRAME GROUND — Four 10-32 Studs and Hardware. Recommended Torque: 23 in-lbs. — FRAME GROUND

POSITIVE (+)  
SOLAR CONVERTER DC INPUT FEED  
1 FEED PER 1 SOLAR CONVERTER  
140 VDC to 200 VDC / 200 VDC to 400 VDC

NEGATIVE (-)

Terminal Block  
for Respective  
Module Position

Wire Size Capacity:  
20 AWG to 6 AWG.  
Recommended Torque:  
13 to 16 in-lbs.

**ALERT!**  
ENSURE PROPER VOLTAGE  
(AC OR DC) IS CONNECTED  
TO EACH MODULE MOUNTING  
POSITION.

**Figure 5.8 Solar Converter DC Input Connections to Rectifier AC Input / Solar Converter DC Input Panel (List 45) (140 VDC to 200 VDC / 200 VDC to 400 VDC)**

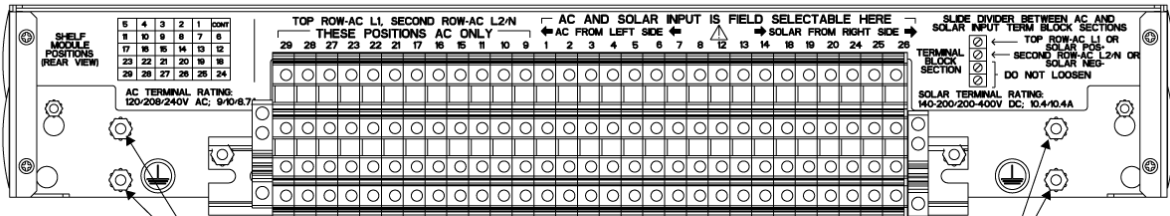
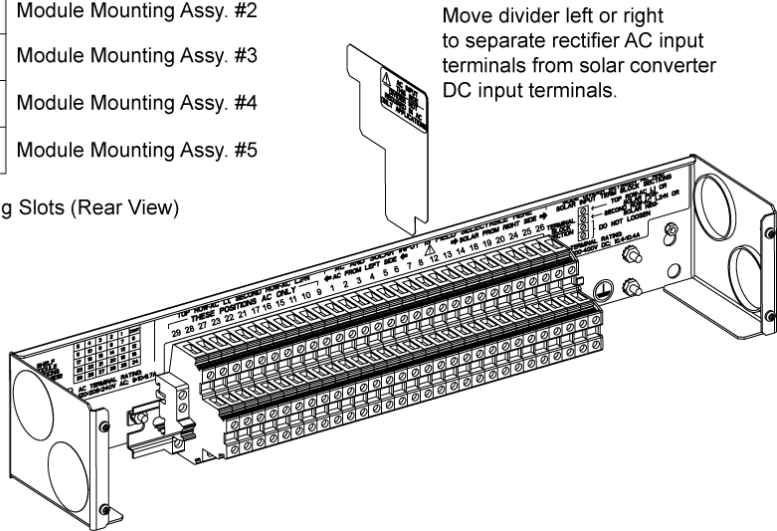
DC INPUT CONNECTIONS (582137100 List 45)  
1 FEED PER 1 SOLAR CONVERTER

5	4	3	2	1	Controller	Module Mounting Assy. #1
11	10	9	8	7	6	Module Mounting Assy. #2
17	16	15	14	13	12	Module Mounting Assy. #3
23	22	21	20	19	18	Module Mounting Assy. #4
29	28	27	26	25	24	Module Mounting Assy. #5

Solar Converter Module Mounting Slots (Rear View)

These module mounting slots cannot be wired for solar converters.

Note:  
Wiring to a field installed module mounting assembly is done at the rear of the module mounting assembly.



FRAME GROUND — Four 10-32 Studs and Hardware. Recommended Torque: 23 in-lbs. — FRAME GROUND

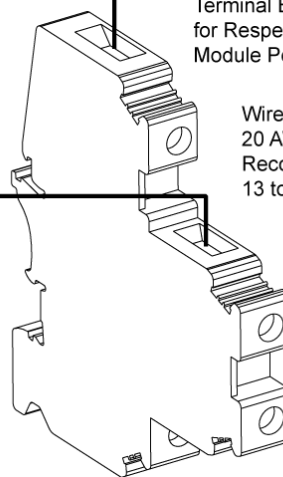
POSITIVE (+)  
SOLAR CONVERTER DC INPUT FEED  
1 FEED PER 1 SOLAR CONVERTER  
140 VDC to 200 VDC / 200 VDC to 400 VDC

NEGATIVE (-)

Terminal Block for Respective Module Position

Wire Size Capacity:  
20 AWG to 6 AWG.  
Recommended Torque:  
13 to 16 in-lbs.

**ALERT!**  
ENSURE PROPER VOLTAGE  
(AC OR DC) IS CONNECTED  
TO EACH MODULE MOUNTING  
POSITION.





### 5.8.3 To 23" Solar Connection Cabinet (List 61)

Provide a solar converter DC input feed to the bottom terminals of each circuit breaker in the List 61 Solar Connection Cabinet. Refer to Figure 5.9 for connection details and recommended torque.



**NOTE!** *The voltage applied to the circuit breakers of List 61 shall not exceed 250 VDC between either the positive or the negative conductor and earth. The individual poles of the circuit breaker are rated for a maximum of 250 VDC.*

Connections are also required between the List 61 Solar Connection Cabinet and the solar converter inputs.

- If List 61 Solar Connection Cabinet is factory installed and NO List 45 Rectifier AC Input / Solar Converter DC Input Panel is furnished, the factory provides the wiring between the List 61 Solar Connection Cabinet and the solar converter inputs in the module mounting assembly(s).
- If List 61 Solar Connection Cabinet is field installed or if additional solar converter circuit breakers are field installed, the customer needs to physically run the provided wire harness between the List 61 Solar Connection Cabinet and the solar converter inputs located in the List 45 Rectifier AC Input / Solar Converter DC Input Panel. Customer is also responsible for providing conduit from the List 61 Solar Connection Cabinet to the List 45 Rectifier AC Input / Solar Converter DC Input Panel. Refer to Figure 5.10 for connection details and recommended torque.

Locate the module position identification label either on the inside of the distribution cabinet door (rack mounted systems) or inside the OSP cabinet when no door is furnished. As the system is being wired for module inputs, write the type of module to be placed in each module mounting position in the space provided on the label. Write R for rectifier, C for converter, and S for solar converter. See Figure 5.6.

### 5.8.4 To Individual Module Mounting Assembly(s) Equipped with Molex Connectors and Provided with Solar Converter DC Input Cable Assemblies

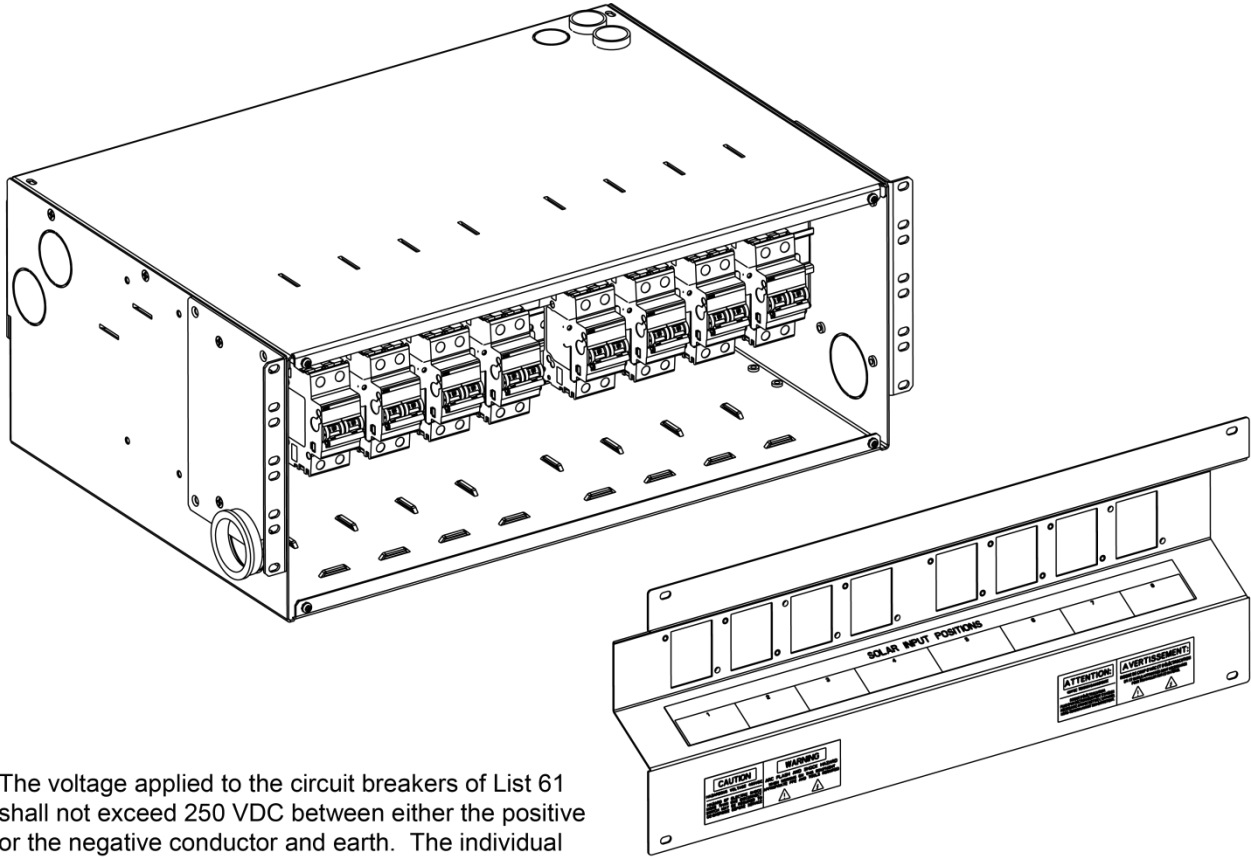
Spec. No. 588705300 module mounting assembly(s) may be equipped with plug-in input connectors located on the rear of the assembly. Input cable assemblies with mating connectors are available (see Power Data Sheet PD588705300). Refer to Power Data Sheet PD588705300 for connection details.

Locate the module position identification label either on the inside of the distribution cabinet door (rack mounted systems) or inside the OSP cabinet when no door is furnished. As the system is being wired for module inputs, write the type of module to be placed in each module mounting position in the space provided on the label. Write R for rectifier, C for converter, and S for solar converter. See Figure 5.6.

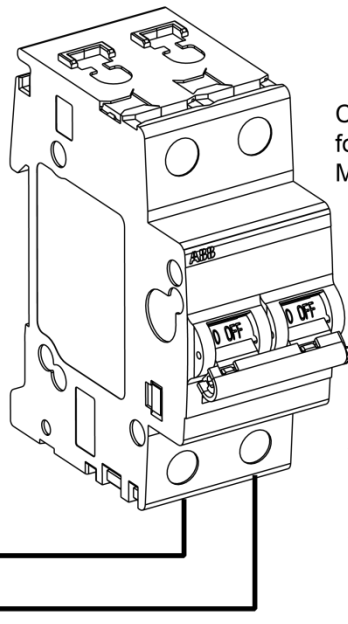
For systems using Molex connected cords and -48 VDC to +24 VDC converters or -48 VDC to -58 VDC converters are being used (List 26 two row distribution panel or List 27 single row distribution panel) in the plant, the following module restrictions apply for factory installed shelves 2 through 5:

- Rectifiers can be in any or all six (6) positions if three (3) AC inputs provided.
- +24V or -58V converters can be in the right three (3) positions (positions 4, 5 and 6).
- Rectifiers can be in any position which has AC power that is not taken up with a converter.
- One (1) Solar converter can be installed in the shelf, position 1 or 2.
- Three (3) solar converters can be installed in the shelf, positions 1 or 2, positions 3 or 4 and positions 5 or 6 if the -48V to +24V or -48V to -58V bus bar is not installed to the shelf above.

**Figure 5.9 Solar Converter DC Input Connections to Solar Connection Cabinet (List 61)  
(140 VDC to 200 VDC / 200 VDC to 400 VDC)**



The voltage applied to the circuit breakers of List 61 shall not exceed 250 VDC between either the positive or the negative conductor and earth. The individual poles of the circuit breaker are rated for a maximum of 250 VDC.

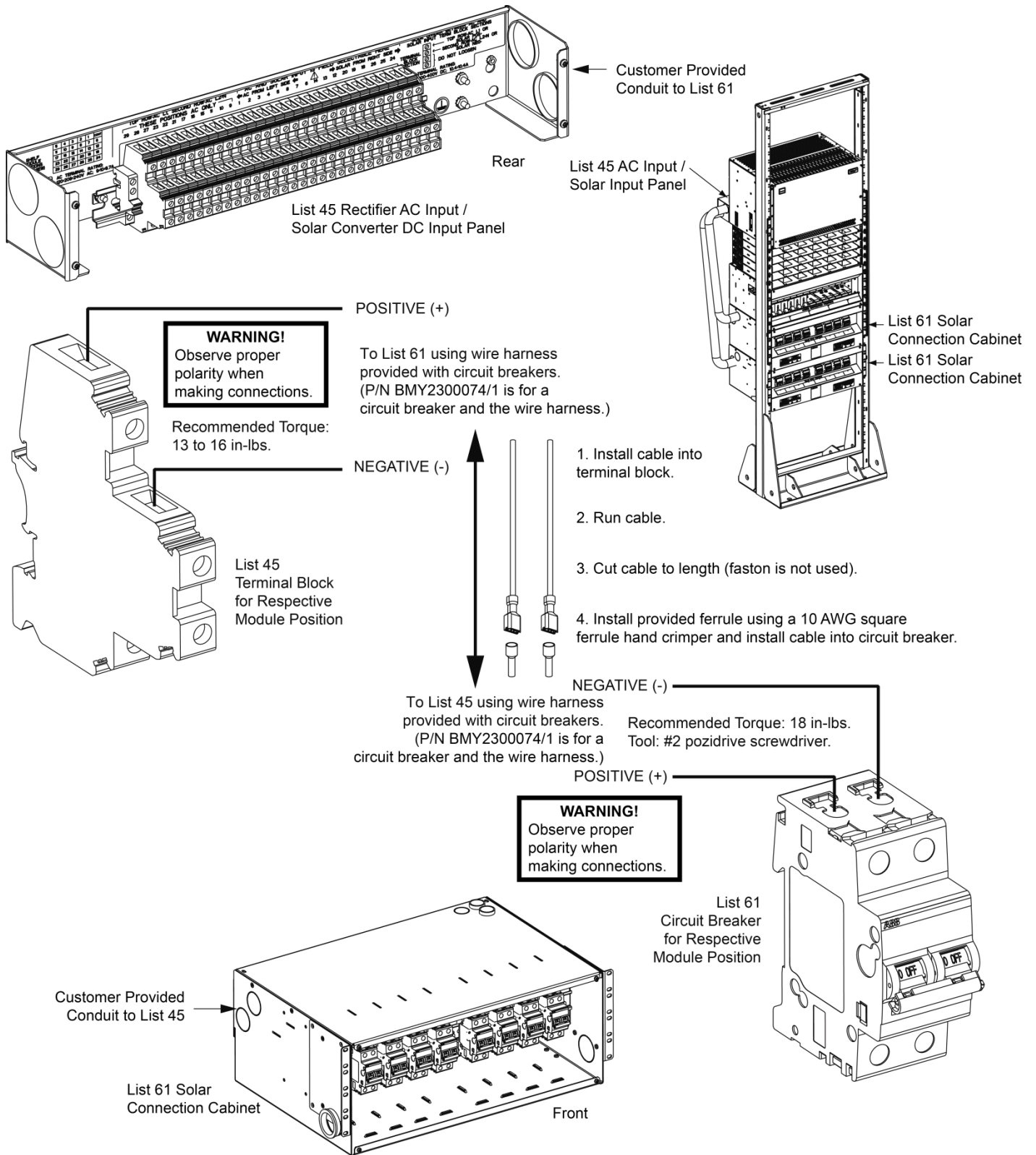


Circuit Breaker for Respective Module Position

SOLAR CONVERTER DC INPUT FEED  
1 FEED PER 1 SOLAR CONVERTER  
140 VDC to 200 VDC / 200 VDC to 400 VDC

Wire Size Capacity: 14 AWG to 4 AWG.  
Strip Length: 0.38 inch.  
Recommended Torque: 18 in-lbs.  
Tool: #2 pozidrive screwdriver.

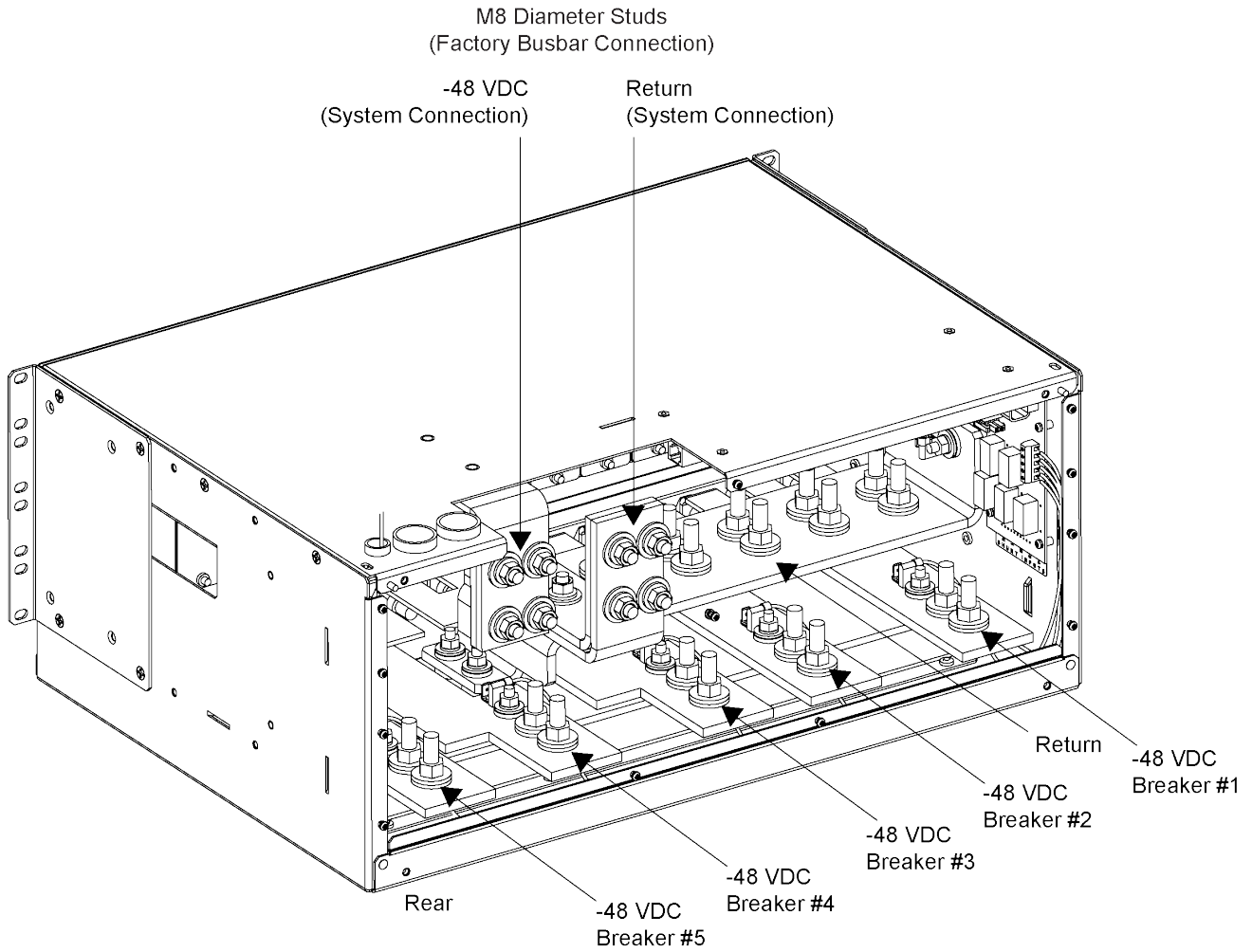
**Figure 5.10 Interconnections between a List 61 Solar Connection Cabinet and a List 45 Rectifier AC Input / Solar Converter DC Input Panel**



## 5.9 -48 VDC System Connections to an Optional List 60 Hybrid Connection Cabinet

-48 VDC system connections to the List 60 Hybrid Connection Cabinet is factory made with system busbars attached to the input terminals. Refer to Figure 5.11 for terminal location.

**Figure 5.11 System Connections to an Optional List 60 Hybrid Connection Cabinet**



3/8" Studs on 1" Centers  
Maximum Lug Width: 2 inches.  
Hardware:  
3/8" Hex Nut  
3/8" Lock Washer  
3/8" Flat Washer  
Torque to 300 in-lbs.

## 5.10 Optional Inverter System Nominal 120 VAC Input and Equipment Grounding Connections (List 50, 51, 52, 53, 54, 55, 56, 57)

The AC input connections are made to an AC input terminal block located in the right-rear of the inverter module mounting shelf portion of the system.

### **Procedure**

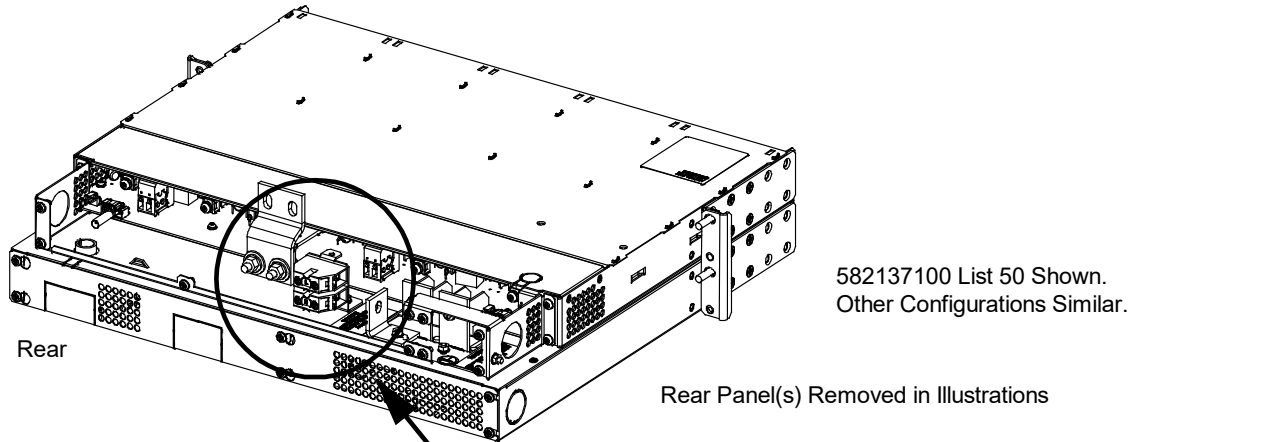
Refer to Figure 5.12 as this procedure is performed.



**NOTE!** A grounding conductor must be provided with each conduit. Make equipment grounding connections to earth ground, not to the branch circuit neutral conductor.

1. Remove the access cover from the rear of the inverter module mounting shelf portion of the system.
2. For Lists 56 and 57, remove the conduit plate from the right side (as viewed from the rear) of the inverter module mounting shelf portion of the system.
3. For Lists 50, 51, 52, and 53; if using the rear panel location, transfer the plug button factory installed in this location to the conduit hole in the right-side panel.
4. Install an appropriate size conduit fitting (see SAG582137100 for details) as required.
5. Route commercial AC input and ground leads into the inverter module mounting shelf portion of the system through the previously installed conduit fitting.
6. Connect the commercial AC input leads to the AC input terminal block inside the inverter module mounting shelf portion of the system as shown in Figure 5.12. Connect each wire by inserting the stripped end into the wire opening, and then tightening the screw. Torque connections to value shown in Figure 5.12.
7. Connect equipment grounding leads to the frame ground stud using installer-provided lug and factory-supplied mounting hardware. Torque connection to value shown in Figure 5.12.
8. After all AC input and equipment grounding connections have been made and checked, reinstall the rear access cover.

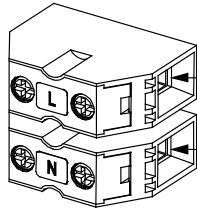
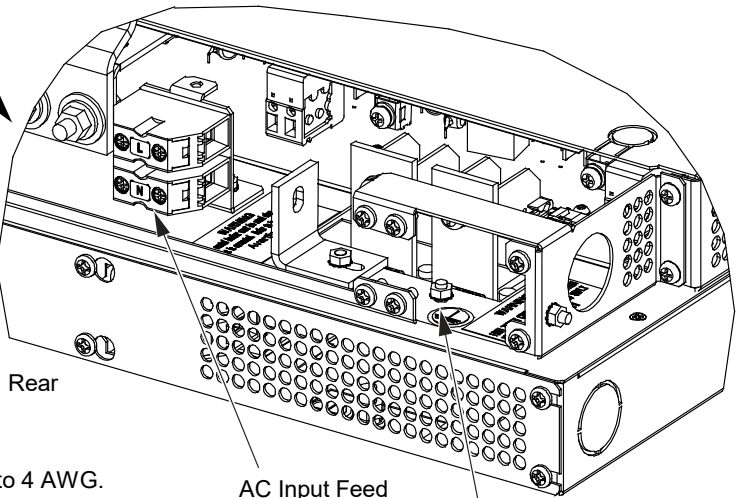
Figure 5.12 Nominal 120 VAC Input and Equipment Grounding Connections



582137100 List 50 Shown.  
Other Configurations Similar.

- 582137100 List 50
- 582137100 List 51
- 582137100 List 52
- 582137100 List 53

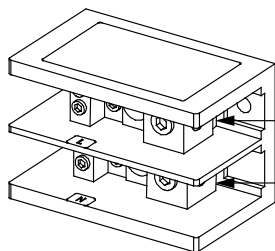
Wire Size Capacity: 20 AWG to 4 AWG.  
Recommended Torque: 26 in-lbs.



Line AC Input Feed Terminal Block  
120 VAC, 50 / 60 HZ,  
Single Phase

Neutral

- 582137100 List 54
  - 582137100 List 55
  - 582137100 List 56
  - 582137100 List 57
- Wire Size Capacity: 14 AWG to 2/0 AWG.  
Recommended Torque:  
35 lbf.in (3.95 N.m) 12 AWG  
35 lbf.in (3.95 N.m) 14 AWG  
40 lbf.in (4.52 N.m) 8 AWG  
120 lbf.in (13.56 N.m) 6 AWG to 2/0 AWG



Line AC Input Feed Terminal Block  
120 VAC, 50 / 60 HZ,  
Single Phase

Neutral

## 5.11 Inverter System AC "Neutral" Reference Point (When DC Input Source Only Connected)

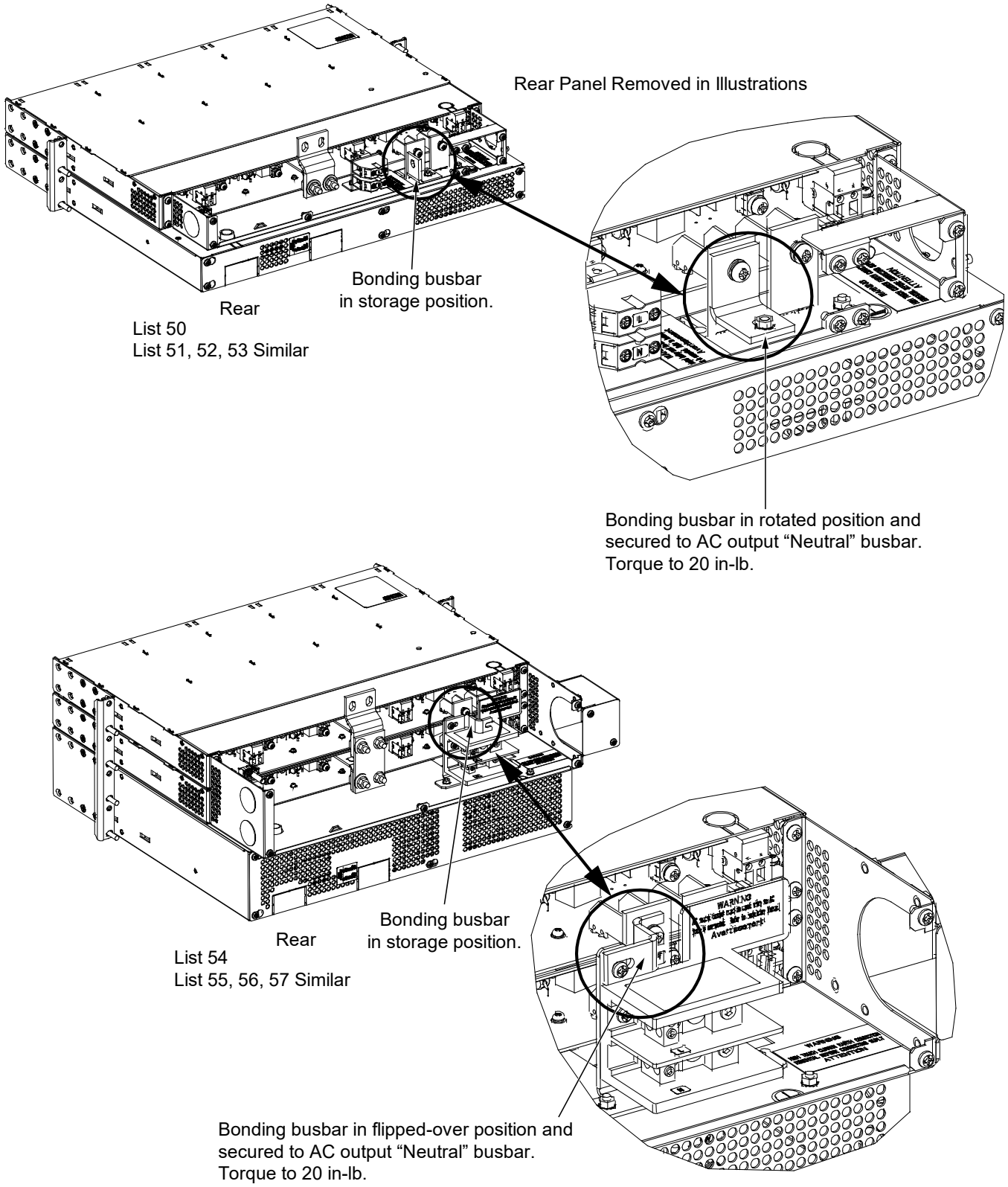
If the input to the inverter system is provided from a DC input source only (no AC input), an AC neutral reference must be provided by bonding the "Neutral" output of the inverter shelf to the frame of the inverter shelf with the furnished bonding busbar. Refer to the following procedure.

### **Procedure**

Refer to Figure 5.13 as this procedure is performed.

1. Remove the access cover from the rear of the inverter module mounting shelf portion of the system.
2. Locate the bonding busbar stored near the AC output neutral busbar. See Figure 5.13.
3. Remove the hardware securing the bonding busbar. Rotate or flip the bonding busbar over as required so it bonds the AC Output "Neutral" busbar to the frame of the inverter shelf. See Figure 5.13. Note that the hardware from the AC Output "Neutral" busbar needs to be removed first in the position where the bonding busbar will be secured. Secure the bonding busbar with the hardware previously removed. Torque the connections as indicated in Figure 5.13.
4. Reinstall the rear access cover.

Figure 5.13 AC "Neutral" Reference Point





## 5.12 Optional Inverter System Nominal 120 VAC Output Connections (List 50, 51, 52, 53, 54, 55, 56, 57)

The AC output connections are made to the AC distribution shelf comprising the system.

### 5.12.1 List 50, 52, 54, 56 (bulk output)

#### **Procedure**

Refer to Figure 5.14 as this procedure is performed.



**NOTE!** A grounding conductor must be provided with each conduit.

1. Remove the access cover from the rear of the AC distribution shelf.
2. Install a 3/4-inch conduit fitting(s) as required in the right-side panel (as viewed from the rear) of the AC distribution shelf.
3. Route AC output and ground leads into the AC distribution shelf through the previously installed conduit fitting(s).
4. Connect the AC output leads to the appropriate AC output terminal block inside the AC distribution shelf as shown in Figure 5.14. Connect each wire by inserting the stripped end into the wire opening, and then tightening the screw. Torque connections to value shown in Figure 5.14.
5. Connect ground leads to the frame ground stud(s) using installer-provided lug(s) and factory-supplied mounting hardware. Torque connections to value shown in Figure 5.14.
6. After all AC output and ground connections have been made and checked, reinstall the rear access cover.

### 5.12.2 List 51, 53, 55, 57 (NEMA output)

#### **Procedure**

Refer to Figure 5.15 as this procedure is performed.

1. Connect the AC output leads to the NEMA 5-15R receptacles provided on the front of the system. See Figure 5.15.

Figure 5.14 Nominal 120 VAC Output Connections, Lists 50, 52, 54, 56 (Bulk Output)

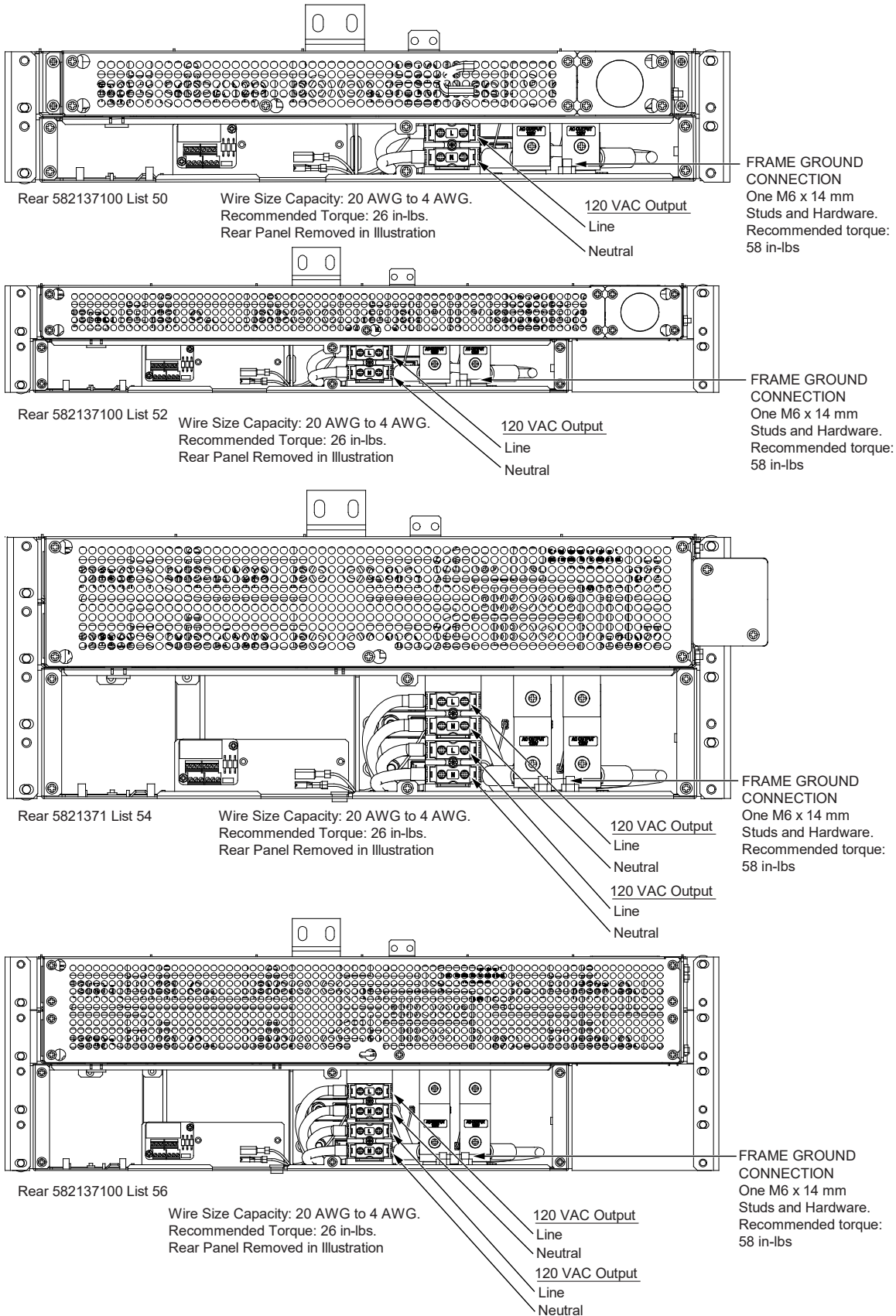
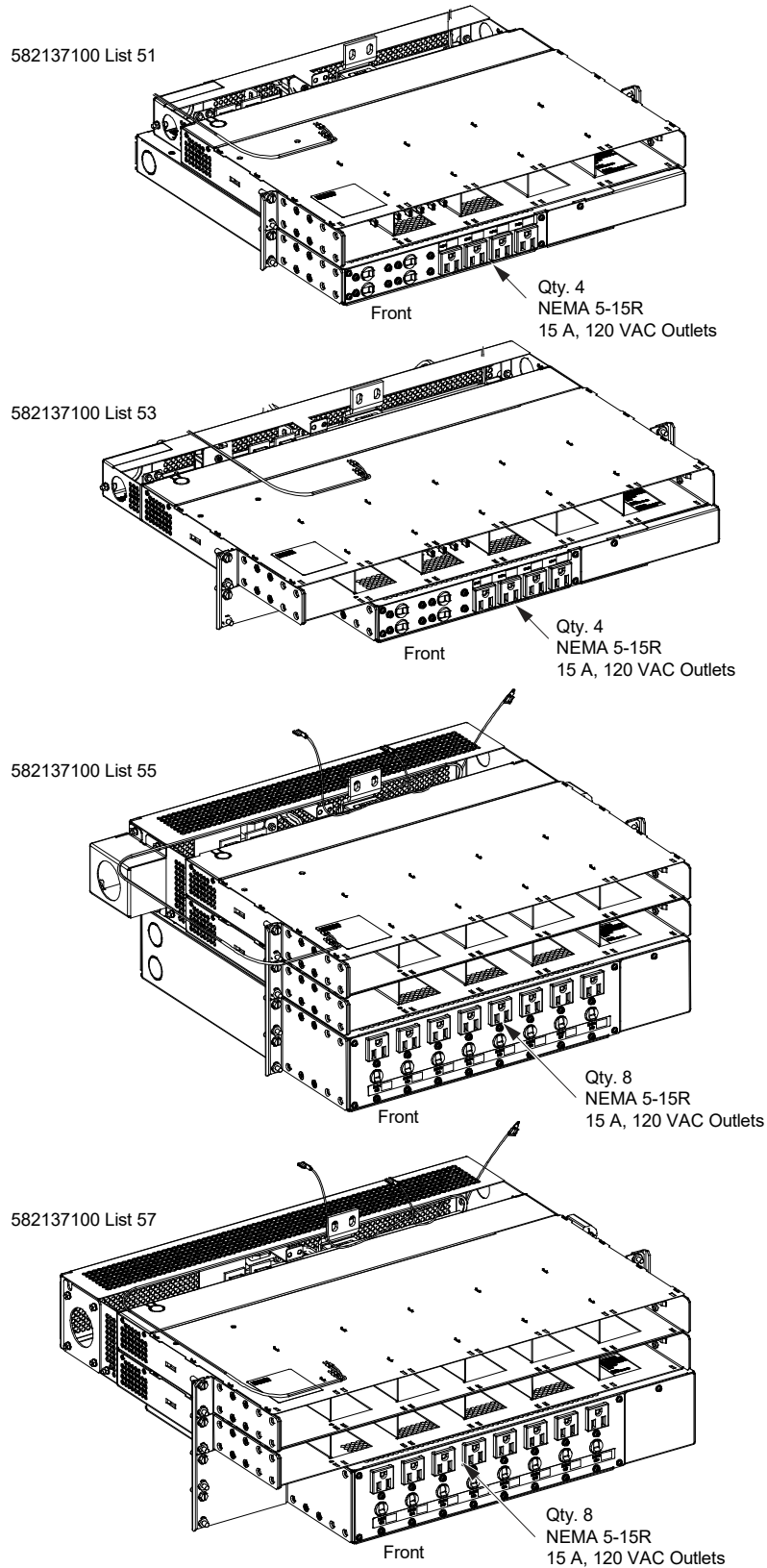


Figure 5.15 Nominal 120 VAC Output Connections, Lists 51, 53, 55, 57 (NEMA Output)

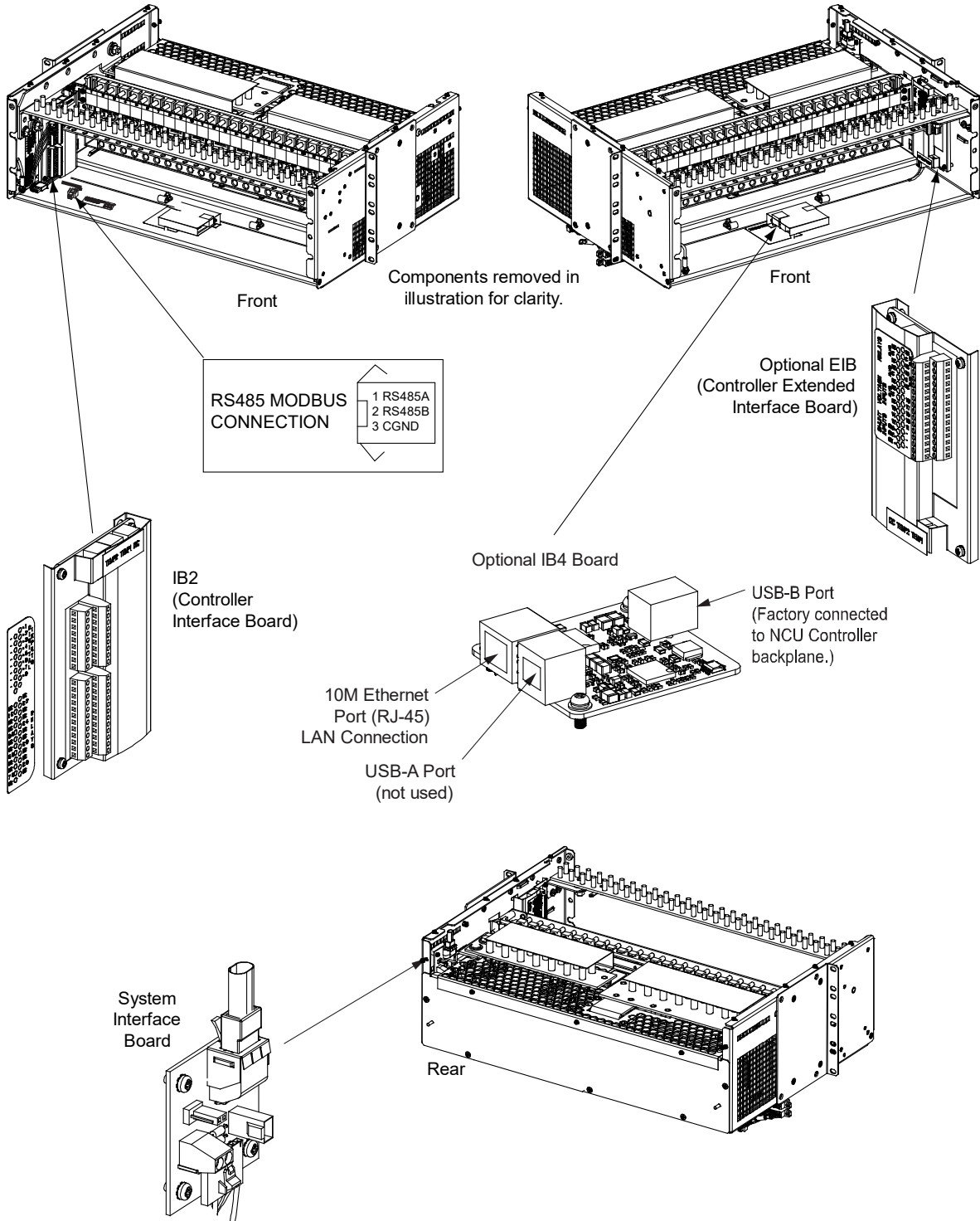


## 5.13 External Alarm, Reference, Monitoring, and Control Connections

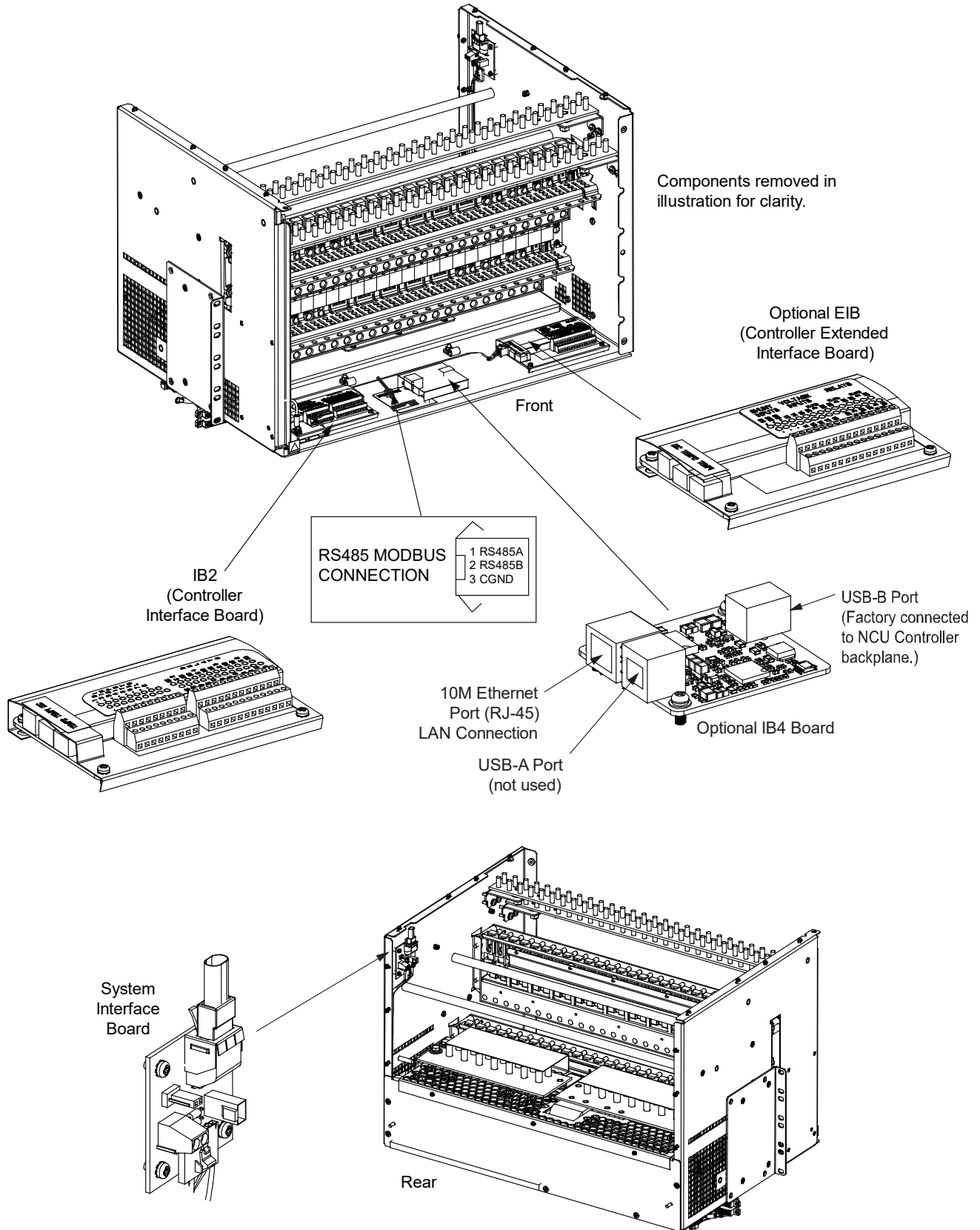
### 5.13.1 External Alarm, Reference, Monitoring, and Control Connection Locations

Refer to Figure 5.16, Figure 5.17, Figure 5.18.

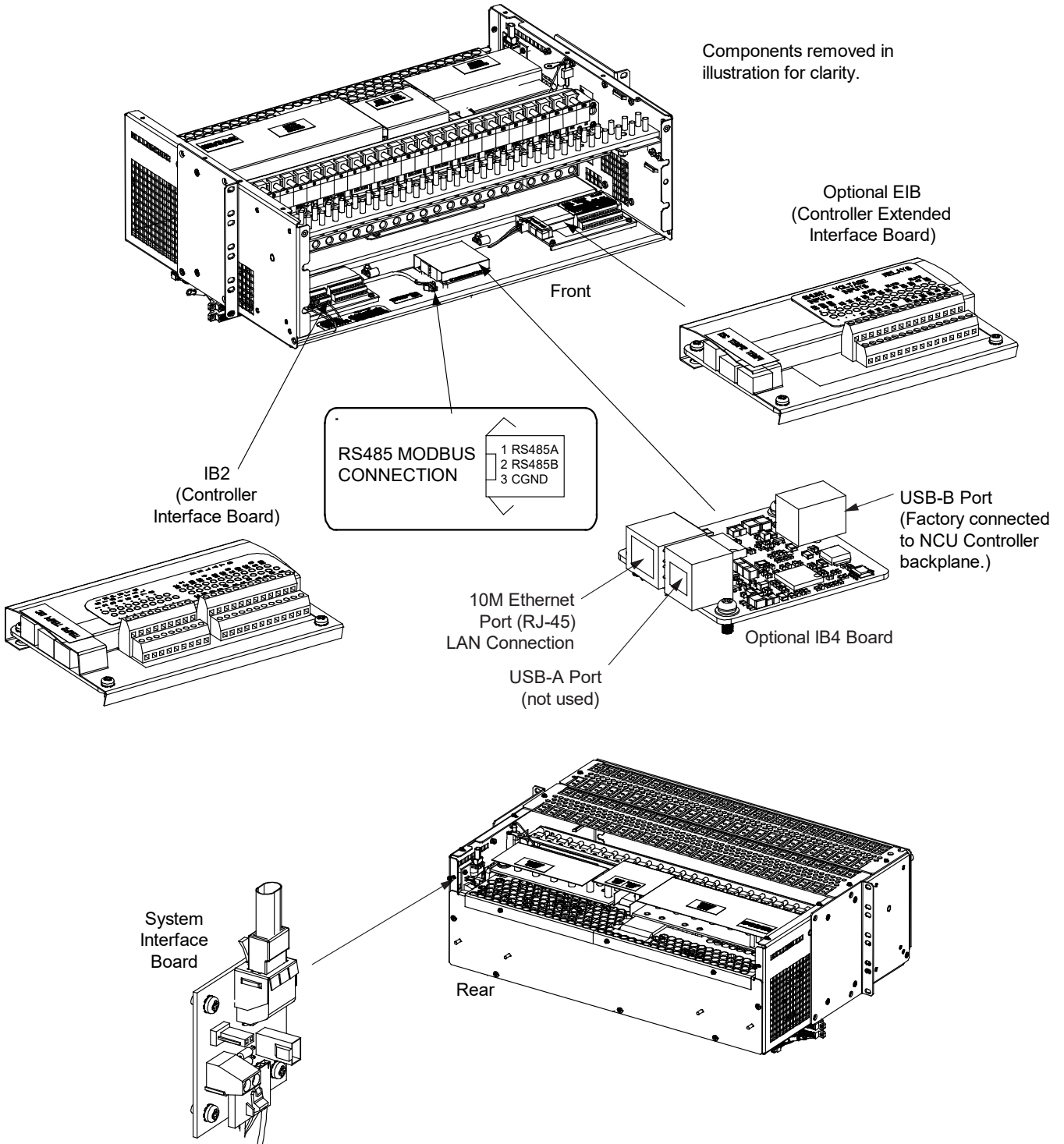
**Figure 5.16** External Alarm, Reference, Monitoring, and Control Connections in a List 20, 25 Distribution Cabinet (see preceding pages for connection details)



**Figure 5.17** External Alarm, Reference, Monitoring, and Control Connections in a List 21, 26 Distribution Cabinet (see preceding pages for connection details)



**Figure 5.18** External Alarm, Reference, Monitoring, and Control Connections in a List 27 Distribution Cabinet (see preceding pages for connection details)

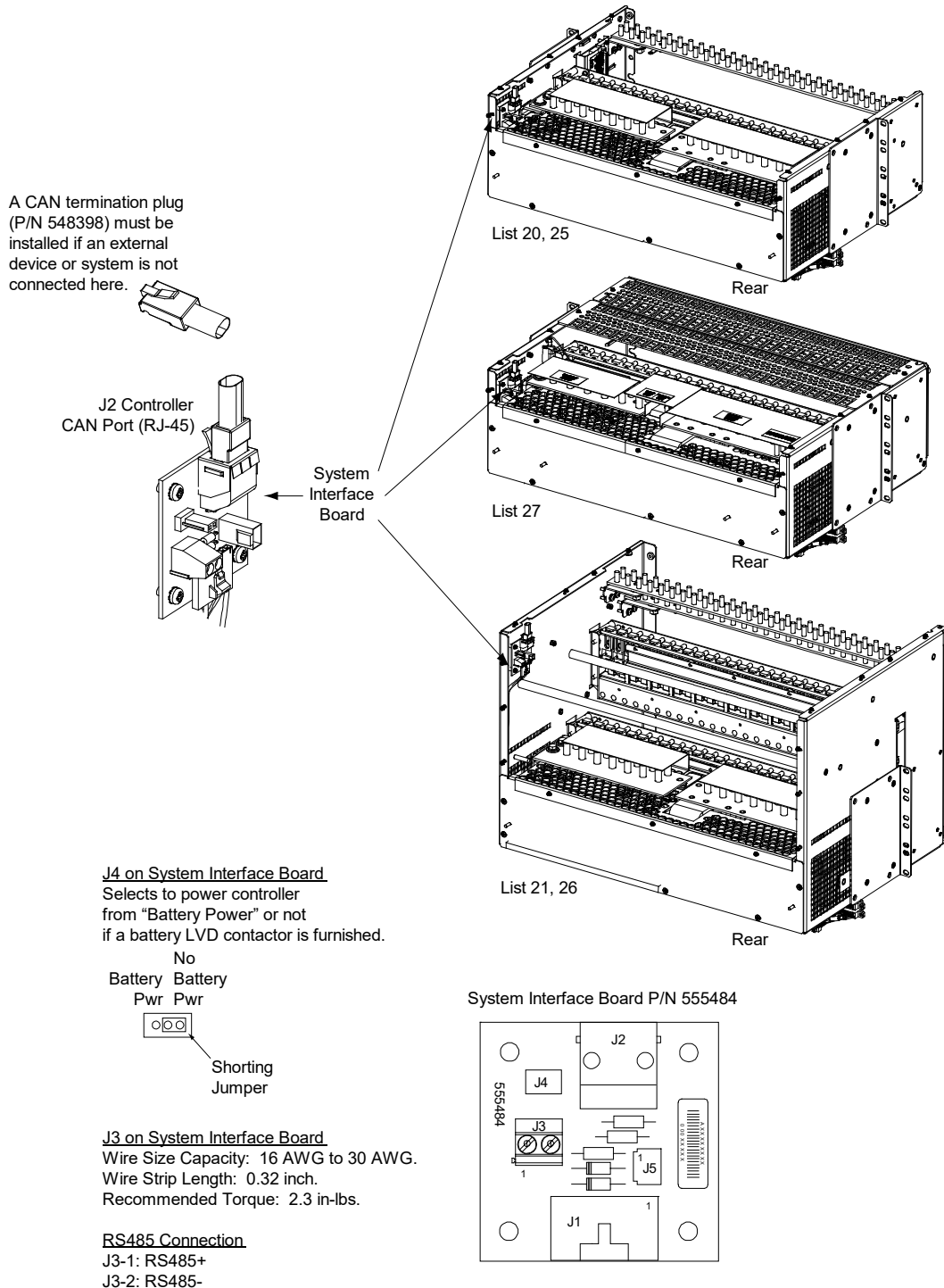


### 5.13.2 System Interface Circuit Card Connections (if required)

The system interface circuit card provides connections for the following. Refer to Figure 5.19 for circuit card location and connections details.

- RS-485 (used for communication with SM modules)

**Figure 5.19 System Interface Circuit Card Connections**



### 5.13.3 RS485 Modbus Connection (if required)

Refer to Figure 5.16, Figure 5.17, or Figure 5.18 for location of the RS485 Modbus connector in the system. Note the an RS485 Modbus interface cable is available (P/N 564643). This cable is 4' long and is terminated at one end with a mating connector and unterminated at the other end. Refer to Table 5.2 for pinouts.

**Table 5.2 RS485 Modbus Connector**

RS485 Modbus Interface Cable P/N 564643		
Pin	Wire Color	Designation
1	Red	RS485A
2	Black	RS485B
3	Green	CGND

### 5.13.4 IB2 (Controller Interface Board) Connections (if required)

The IB2 (Controller Interface Board) provides connection points for digital inputs, programmable relay outputs, and temperature probes. The IB2 interface board is mounted inside the distribution cabinet. Refer to Figure 5.16, Figure 5.17, or Figure 5.18.

#### **Digital Inputs and Programmable Relay Outputs**

Digital input and relay output leads are connected to screw-type terminal blocks located on the IB2. Recommended torque for these connections is 2.2 in-lbs. Refer to Figure 5.20 for terminal locations. Refer to Table 5.3, Table 5.4, and Table 5.5 for pin-out information.



**NOTE!** Two sets of alarm cables are available (see SAG582137100 for part numbers). One set for the digital inputs and another set for the relay outputs. Refer to Table 5.3 and Table 5.5 for color scheme. If the Relay Outputs Alarm Cable or Digital Inputs Alarm Cable is ordered, one half is factory connected in the distribution cabinet. The other half has a mating connector on one end and is un-terminated on the other end.



**NOTE!** A custom digital input cable kit is available. Refer to Table 5.4 for color scheme.



**CAUTION!** All conductors in this harness may be connected within the cabinet. Shorting or grounding of unused conductors may result in service interruption or equipment damage. Therefore, insulate all conductor ends not being used in your application.

#### **Digital Inputs**

Connect up to seven (7) digital inputs to the IB2. Note that you must supply both paths for the digital input (either a positive or negative signal and the opposite polarity return path). Observe proper polarity. Refer to Figure 5.20 for terminal locations and Table 5.3 or Table 5.4 for pin-out information.

The digital inputs can be programmed to provide an alarm when the signal is applied (HIGH) or removed (LOW). Refer to the NCU Instructions (UM1M830BNA) for programming information.

Digital Input Ratings: Refer to the following.

- a) Maximum Voltage Rating: 60V DC.
- b) Active High: > 19V DC.
- c) Active Low: < 1V DC.



The digital inputs may be preprogrammed for specific functions. Refer to the configuration drawing (C-drawing) supplied with your system for your system's specific configuration.

### **Power System ESTOP Function**

If an ESTOP switch is wired to the IB2-1 Controller Interface Board, customer-furnished system ground applied to terminal DI8+ activates the ESTOP function. The ESTOP function shuts down and locks out the rectifiers and solar converters, shuts down and locks out the optional -48 VDC to +24 VDC converters or optional -48 VDC to -58 VDC converters, shuts down and locks out the inverters (if equipped with optional inverter system), and opens the optional low voltage disconnect (LVD) contactors (battery and load type). If the system has battery connected and does not contain a battery LVD or the controller power option is set to Battery Pwr (jumper J4 on the system interface board is set to Battery Pwr), the controller will remain operational. If the system does not contain battery or load LVD(s) and has battery connected, the loads will be sustained by the battery voltage.

For Systems NOT Containing a Battery LVD: When the ESTOP signal is removed, LVD contactors (load type) will close after the "LVD Reconnect Delay" has elapsed (customer configurable via the controller) if battery voltage is present on the bus. Rectifiers, solar converters, optional -48 VDC to +24 VDC converters or optional -48 VDC to -58 VDC converters, and inverters (if equipped with optional inverter system) will remain off. The rectifiers, solar converters, and inverters (if equipped with optional inverter system) will restart when the input power to these is removed and restored after 30 seconds or more (until the LEDs on the modules extinguish). To restart the -48 VDC to +24 VDC converters or -48 VDC to -58 VDC converters: remove the converter, wait 30 seconds or more (until the LEDs on the converter extinguish), then re-insert the converter.

For Systems Containing a Battery LVD: When the ESTOP signal is removed, LVD contactors (battery and load type) will remain open. Rectifiers, solar converters, optional -48 VDC to +24 VDC converters or optional -48 VDC to -58 VDC converters, and inverters (if equipped with optional inverter system) will remain off. The rectifiers and solar converters will restart when the input power to these is removed and restored after 30 seconds or more (until the LEDs on the modules extinguish). When the rectifiers restart, LVD contactors (battery and load type) will close after the "LVD Reconnect Delay" has elapsed (customer configurable via the controller) and the -48 VDC to +24 VDC converters or -48 VDC to -58 VDC converters, and inverters (if equipped with optional inverter system) will restart.



**NOTE!** *If a customer-furnished method to disconnect the input power to the system is not provided, the rectifiers will stay locked OFF until the input power is recycled. If the ESTOP signal is removed without recycling the input power, the rectifiers will remain off and have a local alarm visible on the module. The ESTOP alarm from the controller will extinguish. The controller will not issue an alarm for this condition.*

### **Inverter System EPO Function**

The inverter system contains an EPO (Emergency Power Off) function. Connection points for a normally closed external EPO switch are provided on the customer interface board. If an external EPO switch is wired to the customer interface board, activating the switch to open the circuit activates the EPO function. The EPO function shuts down and locks out the inverters. When the EPO switch is returned to normal (closed loop), the inverters remain off. The inverters will restart when the AC and DC power inputs are removed and restored after 30 seconds or more (until the LEDs on the modules extinguish) (depending on the synchronizing time with the system). (Note that there is an EPO shorting link factory installed that can be replaced with a customer provided switch.)



**NOTE!** *If a customer-furnished method to disconnect the AC and DC power inputs to the system is not provided, the inverters will stay locked OFF until the input power is recycled. If the EPO switch is returned to normal (closed loop) without recycling the input power, the inverters will remain off and have a local alarm visible on the module. The EPO alarm from the controller will extinguish. The controller will not issue an alarm for this condition.*



**NOTE!** *The power system's ESTOP function described above is factory wired into the inverter system's EPO function. If an EPO switch is not wired, the inverter system will still respond to the power system's ESTOP function.*

### **External Battery Disconnect Circuit Breaker Alarm Input**

Connect the alarm lead from an optional external battery disconnect unit or the battery disconnect circuit breaker on an optional battery tray to the negative (–) side of Digital Input #3 (terminal 5 of connector J3). –48VDC is applied to the alarm lead when the circuit breaker is in the OFF position. Refer to Figure 5.21.

### **Programmable Relay Outputs**

The IB2 provides eight (8) programmable alarm relays with dry Form-C contacts. Connect up to eight (8) relay outputs to the IB2. Refer to Figure 5.20 for terminal locations and Table 5.5 for pin-out information.

Refer to the NCU Instructions (UM1M830BNA) for programming information.

Relay Ratings: Refer to the following.

- a) Steady State: 0.5 A @ 60V DC; 1.0 A @ 30V DC.
- b) Peak: 3 A @ 30V DC.

The relays may be preprogrammed for specific functions. Refer to the configuration drawing (C-drawing) supplied with your system for your system's specific configuration.

### **Temperature Probes**



**NOTE!** Each temperature probe consists of two or three pieces that plug together to make a complete probe. See SAG582137100 for part numbers and descriptions.

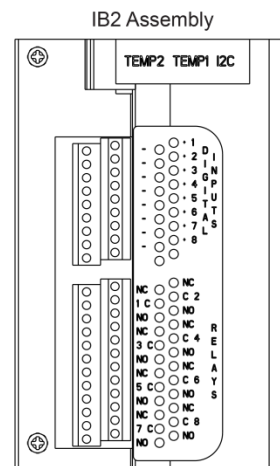
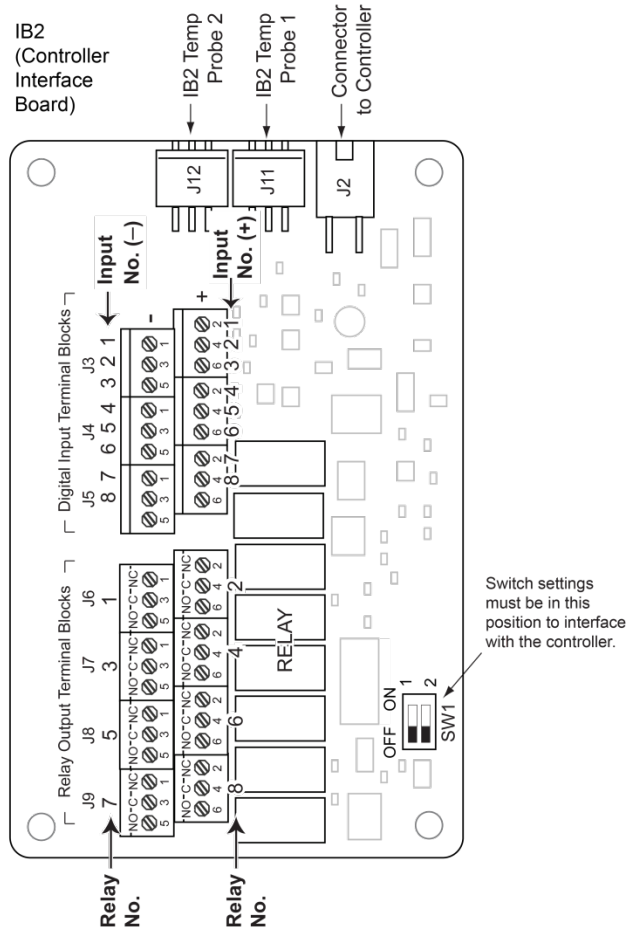
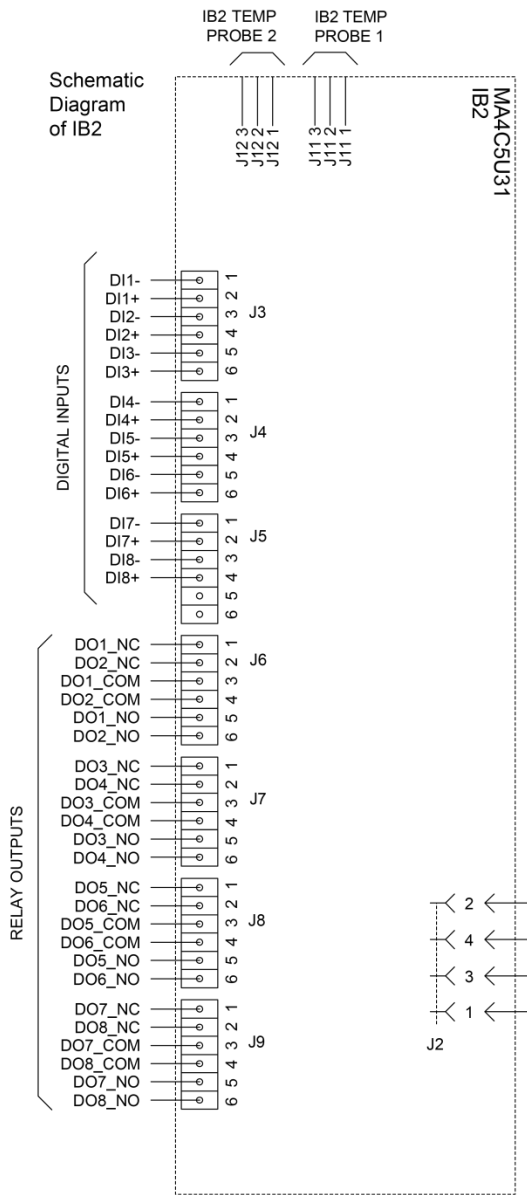
Temperature probes are connected to the IB2 (Controller Interface Board) and/or optional EIB (Controller Extended Interface Board) mounted inside the distribution cabinet.

Up to two (2) temperature probes can be connected to the IB2. Up to two (2) additional temperature probes can be connected to the EIB. Any combination of the four (4) temperature probes can be programmed to monitor ambient temperature and/or battery temperature. A temperature probe set to monitor battery temperature can also be used for the rectifier battery charge temperature compensation feature, or the battery charge temperature compensation feature can be programmed to use the average or highest value of all battery temperature probes. The battery charge temperature compensation feature allows the controller to automatically increase or decrease the output voltage of the system to maintain battery float current as battery temperature decreases or increases, respectively. Battery life can be extended when an optimum charge voltage to the battery with respect to temperature is maintained. A temperature probe set to monitor battery temperature can also be used for the BTRM (Battery Thermal Runaway Management) feature. The BTRM feature lowers output voltage when a high temperature condition exists to control against battery thermal runaway.

The temperature sensor end of the probe contains a tab with a 5/16" clearance hole for mounting.

A temperature probe programmed to monitor battery temperature should be mounted on the negative post of a battery cell to sense battery temperature. A temperature probe used for battery charge temperature compensation and/or BTRM (Battery Thermal Runaway Management) should also be mounted on the negative post of a battery cell. A temperature probe programmed to monitor ambient temperature should be mounted in a convenient location, away from direct sources of heat or cold.

Figure 5.20 IB2 (Controller Interface Board) Connections



\* The controller relay assigned to "Critical Summary" alarm (relay 1 by default) will operate in the "Fail Safe Mode". "Fail Safe Mode" means Relay 1 is de-energized during an alarm condition, opening the contacts between the C and NO terminals, and closing the contacts between the C and NC terminals.

The controller's remaining seven (7) relays energize during an alarm condition, closing the contacts between the C and NO terminals, and opening the contacts between the C and NC terminals.

Not all I/O points are available for customer connection (some are used for factory system connections).

**J3-J9:**

- Wire Size Capacity: 16 AWG to 26 AWG.
- Wire Strip Length: 0.20 inch.
- Recommended Torque: 2.2 in-lbs.

**Table 5.3 Programmable Digital Inputs (Factory Default) – IB2, Standard Cable P/N 541311**

Programmable Digital Input	IB2 Pin No.		P/N 541311 Digital Input Cable Color Scheme	Factory Wiring	Dedicated to...
1	J3-2	+	--	Ground	Internal -48 VDC Load Circuit Breaker / Fuse Alarm
	J3-1	-	--	-48 VDC Load CBA / FA	
2	J3-4	+	--	+24 VDC Load CBA / FA	Internal +24 VDC Load Circuit Breaker / Fuse Alarm
	J3-3	-	--	Ground	
3	J3-6	+	--	Ground	Internal Battery Circuit Breaker / Fuse Alarm or External Battery Circuit Breaker / Fuse Alarm
	J3-5	-	(also for external battery CBA / FA signal)	Internal Battery CBA / FA	
4	J4-2	+	--	Ground	List 60 Hybrid Connection Cabinet (if furnished) Circuit Breaker Alarm or User Defined
	J4-1	-	S-W (for List 60 CBA / FA signal)	--	
5	J4-4	+	W-BR	--	User Defined
	J4-3	-	BR-W	--	
6	J4-6	+	W-G	--	User Defined
	J4-5	-	G-W	--	
7	J5-2	+	W-O	--	User Defined
	J5-1	-	O-W	--	
8	J5-4	+	W-BL (for ESTOP signal)	--	Emergency Stop
	J5-3	-	--	-48 VDC	
--	J5-5		Not Used		
--	J5-6				



**CAUTION!** All conductors in this harness may be connected within the cabinet. Shorting or grounding of unused conductors may result in service interruption or equipment damage. Therefore, insulate all conductor ends not being used in your application.



**NOTE!** -48V is factory wired to the Digital Input #8 (-) terminal for your convenience and function predefined for ESTOP. Customer-furnished system ground applied to terminal Digital Input #8 (+) activates the ESTOP function. See Power System ESTOP Function on page 97.

Table 5.4 Programmable Digital Inputs (Factory Default) – IB2, Special Application Cable P/N 563753

Programmable Digital Input	IB2 Pin No.		Special Application Cable P/N 563753 Color Scheme	Dedicated to...
1	J3-2	+	Brown	User Defined
	J3-1	-	None	
2	J3-4	+	Orange	User Defined
	J3-3	-	-48 VDC Applied Internally	
3	J3-6	+	Violet	User Defined
	J3-5	-	-48 VDC Applied Internally	
4	J4-2	+	Slate	User Defined
	J4-1	-	-48 VDC Applied Internally	
5	J4-4	+	Black	User Defined
	J4-3	-	-48 VDC Applied Internally	
6	J4-6	+	Blue	User Defined
	J4-5	-	-48 VDC Applied Internally	
7	J5-2	+	White	User Defined
	J5-1	-	-48 VDC Applied Internally	
8	J5-4	+	None	Emergency Stop or User Defined
	J5-3	-	Y (factory wired) (see note below)	
--	J5-5		not used	--
	J5-6			



**CAUTION!** All conductors in this harness may be connected within the cabinet. Shorting or grounding of unused conductors may result in service interruption or equipment damage. Therefore, insulate all conductor ends not being used in your application.



**NOTE!** -48V is factory wired to the Digital Input #8 (-) terminal for your convenience and function can be predefined for ESTOP or another function defined by the User. If defined as ESTOP, customer-furnished system ground applied to terminal Digital Input #8 (+) activates the ESTOP function. See Power System ESTOP Function on page 97.

**Table 5.5 Relay Outputs (Factory Default) – IB2**

Programmable Relay Output	IB2 Pin No.	P/N 541309 Alarm Cable Color Scheme	Alarms Assigned to this Relay (Default)	Alarms Assigned to this Relay (Custom)
1*	NO	J6-5	W-BL	Any Critical Alarm
	COM	J6-3	BL-W	
	NC	J6-1	W-O	
2	NO	J6-6	O-W	Any Major Alarm
	COM	J6-4	W-G	
	NC	J6-2	G-W	
3	NO	J7-5	W-BR	DC Volt High #1
	COM	J7-3	BR-W	
	NC	J7-1	W-S	
4	NO	J7-6	S-W	Batt Discharge DC Volt Low #1
	COM	J7-4	R-BL	
	NC	J7-2	BL-R	
5	NO	J8-5	R-O	DC Volt Low #2
	COM	J8-3	O-R	
	NC	J8-1	R-G	
6	NO	J8-6	G-R	AC Failure
	COM	J8-4	R-BR	
	NC	J8-2	BR-R	
7	NO	J9-5	R-S	Fuse Alarm
	COM	J9-3	S-R	
	NC	J9-1	BK-BL	
8	NO	J9-6	BL-BK	Load Share Alarm Rect Not Respond Rect HVSD Rect AC Fail Rect Failure Rect Protect Rect Fan Fail Rect Derated Rect Temp Alarm
	COM	J9-4	BK-O	
	NC	J9-2	O-BK	



**CAUTION!** All conductors in this harness may be connected within the cabinet. Shorting or grounding of unused conductors may result in service interruption or equipment damage. Therefore insulate all conductor ends not being used in your application.



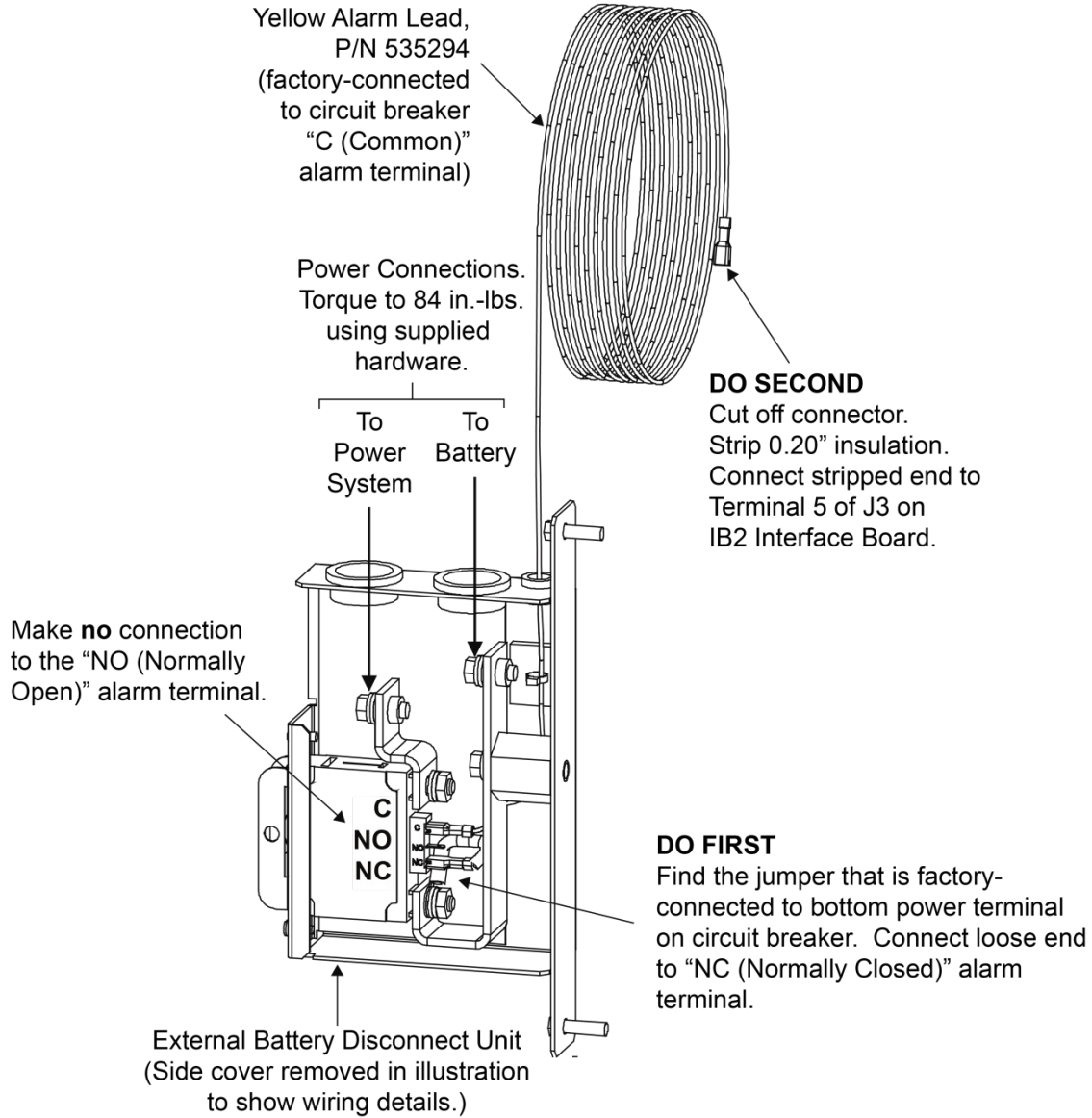
**NOTE!** The controller relay assigned to “Critical Summary” alarm (relay 1 by default) will operate in the “Fail Safe Mode”. “Fail Safe Mode” means Relay 1 is de-energized during an alarm condition, opening the contacts between the C and NO terminals, and closing the contacts between the C and NC terminals. The controller’s seven (7) remaining relays energize during an alarm condition, closing the contacts between the C and NO terminals, and opening the contacts between the C and NC terminals.



**NOTE!** The output relay configuration may not be set according to the factory default setting. Refer to the configuration drawing (C-drawing) supplied with your system for your system’s specific configuration.

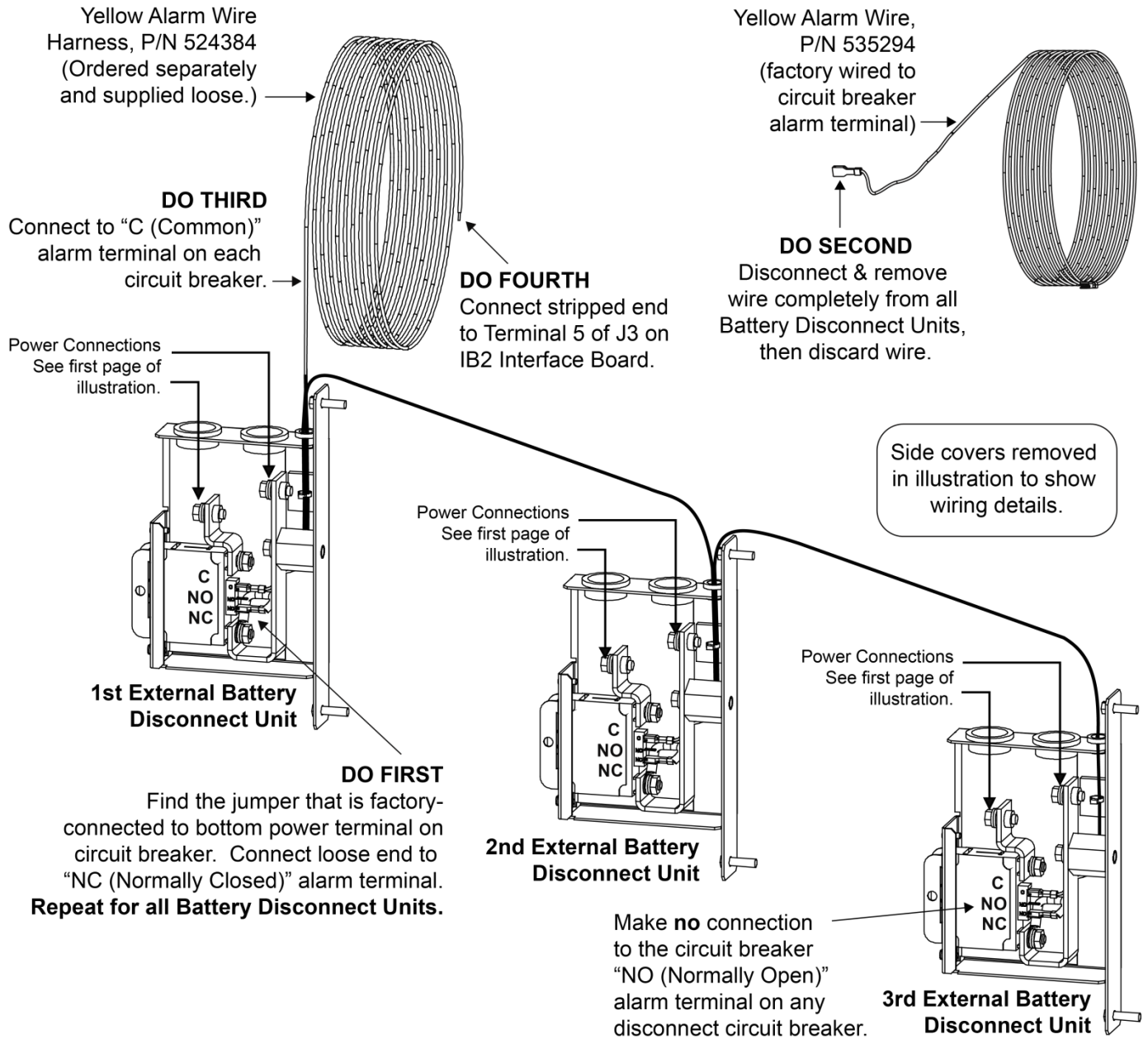
Figure 5.21 External Interface Connections to External Battery Disconnect Unit(s) (cont'd on next page)

### Alarm Wiring to a Single External Battery Disconnect Unit



**Figure 5.21 External Interface Connections to External Battery Disconnect Unit(s) (cont'd from previous page and on next page)**

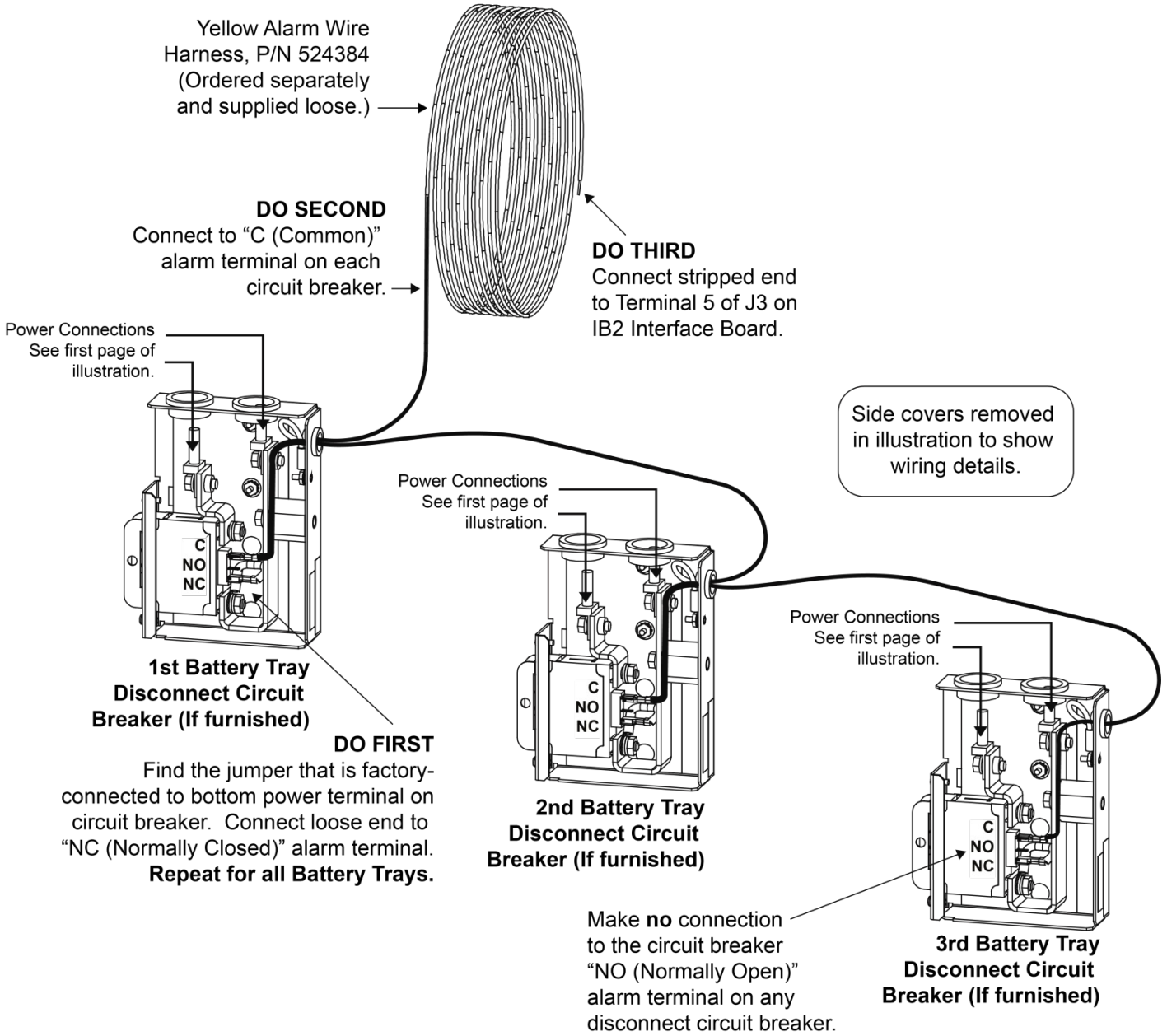
### Alarm Wiring to (2) or (3) External Battery Disconnect Units





**Figure 5.21 External Interface Connections to Disconnect Circuit Breakers on Battery Tray(s)**  
(cont'd from previous page)

**Alarm Wiring to Battery Disconnect Circuit Breakers when (1) to (3) Battery Trays are Used (Factory-connected if ordered with system)**



### 5.13.5 Optional EIB (Controller Extended Interface Board) Connections (if required)

The optional EIB (Controller Extended Interface Board) provides additional connection points for voltage and current inputs, programmable relay outputs, and temperature probes. The EIB extended interface board is mounted inside the distribution cabinet. Refer to Figure 5.16, Figure 5.17, or Figure 5.18.

#### **Current Inputs, Voltage Inputs, and Programmable Relay Outputs**

Current input, voltage input, and relay output leads are connected to screw-type terminal blocks located on the EIB. Recommended torque for these connections is 2.2 in-lbs. Refer to Figure 5.22 for terminal locations. Refer to Table 5.6, Table 5.7, and Table 5.8 for pin-out information.

#### **Current Inputs**

Connect up to three (3) shunt inputs to the EIB. Observe proper polarity. Refer to Figure 5.22 for terminal locations and Table 5.6 for pin-out information.

Refer to the NCU Instructions (UM1M830BNA) and program the shunt input parameters found in the EIB menu.



**NOTE!** *The shunt needs to be installed in the hot (-48V) bus. Connect the plus side of the shunt to the positive shunt input on the EIB. Connect the negative side of the shunt to the negative shunt input on the EIB.*

#### **Voltage Inputs for Battery Block and Battery Midpoint Monitoring**

The NCU can monitor battery blocks (12V blocks) or midpoint battery voltage of battery strings connected to the EIB. The EIB provides a total of eight (8) DC voltage inputs for these connections. An alarm is issued when either battery block voltage or battery midpoint voltage is abnormal. Refer to Figure 5.22 for terminal locations and Table 5.7 for pin-out information.

Refer to Figure 5.23 for connection details. Refer to the NCU Instructions (UM1M830BNA) and program the following parameters found in the EIB menu.

- **Midpoint Monitoring**

Voltage Type: Set to “Midpoint”. This selects the EIB to monitor the midpoint voltage of up to eight (8) battery strings.

BlockVDiff (Mid): This menu item appears if “Midpoint” is selected above. Set to the alarm threshold for battery midpoint monitoring per site requirements. The NCU issues an alarm when any battery midpoint voltage of any battery string has an abnormal value. The alarm is issued when the difference between any battery midpoint voltage and a reference voltage is greater than the value of the block voltage difference setting.

Block In-Use: Set to number of 12V battery blocks being used.

- **Battery Block Monitoring**

Voltage Type: Set to “48 (Block 4)”. This selects the EIB to monitor up to two (2) 48V battery strings with four (4) 12V blocks per string.

BlockVDiff (12V): This menu item appears if “48 (Block 4)” is selected above. Set to the alarm threshold for battery block monitoring per site requirements. The NCU issues an alarm when any block voltage of any battery string has an abnormal value. The alarm is issued when the difference between any block voltage and a reference voltage is greater than the value of the block voltage difference setting.

Block In-Use: Set to the number of 12V battery blocks being used.

#### **Programmable Relay Outputs**

The EIB provides five (5) programmable alarm relays with dry Form-C contacts. Connect up to five (5) relay outputs to the EIB. Refer to Figure 5.22 for terminal locations and Table 5.7 for pin-out information.

Refer to the NCU Instructions (UM1M830BNA) for programming information.

Relay Ratings: Refer to the following.

- a) Steady State: 0.5 A @ 60V DC; 1.0 A @ 30V DC.
- b) Peak: 3 A @ 30V DC.

The relays may be preprogrammed for specific functions. Refer to the configuration drawing (C-drawing) supplied with your system for your system's specific configuration.

### **Temperature Probes**

Temperature probes can be connected to the EIB (NCU Extended Interface Board) mounted inside the distribution cabinet. Refer to "Temperature Probes" on page 98.

**Figure 5.22** Optional EIB (Controller Extended Interface Board) Connections

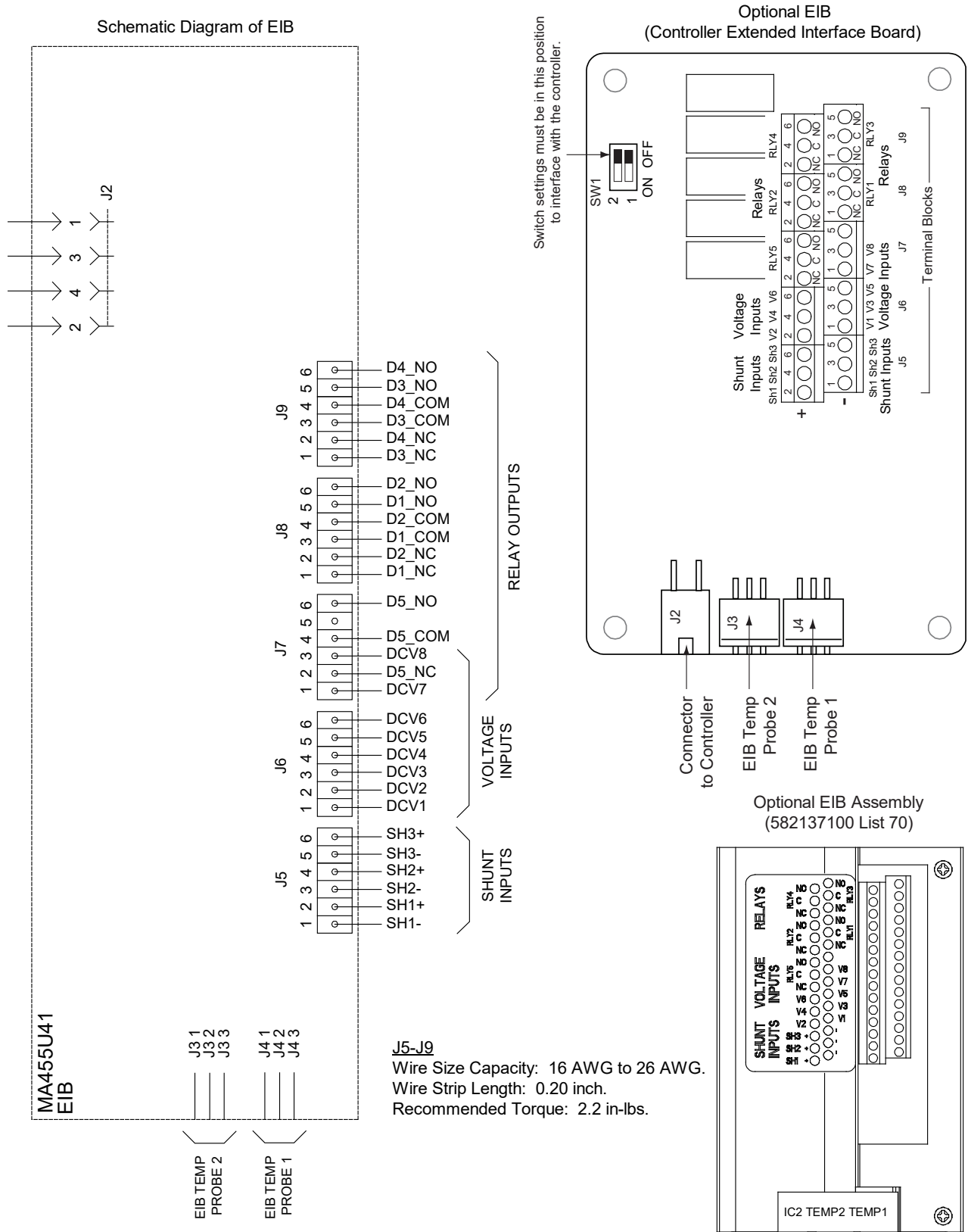
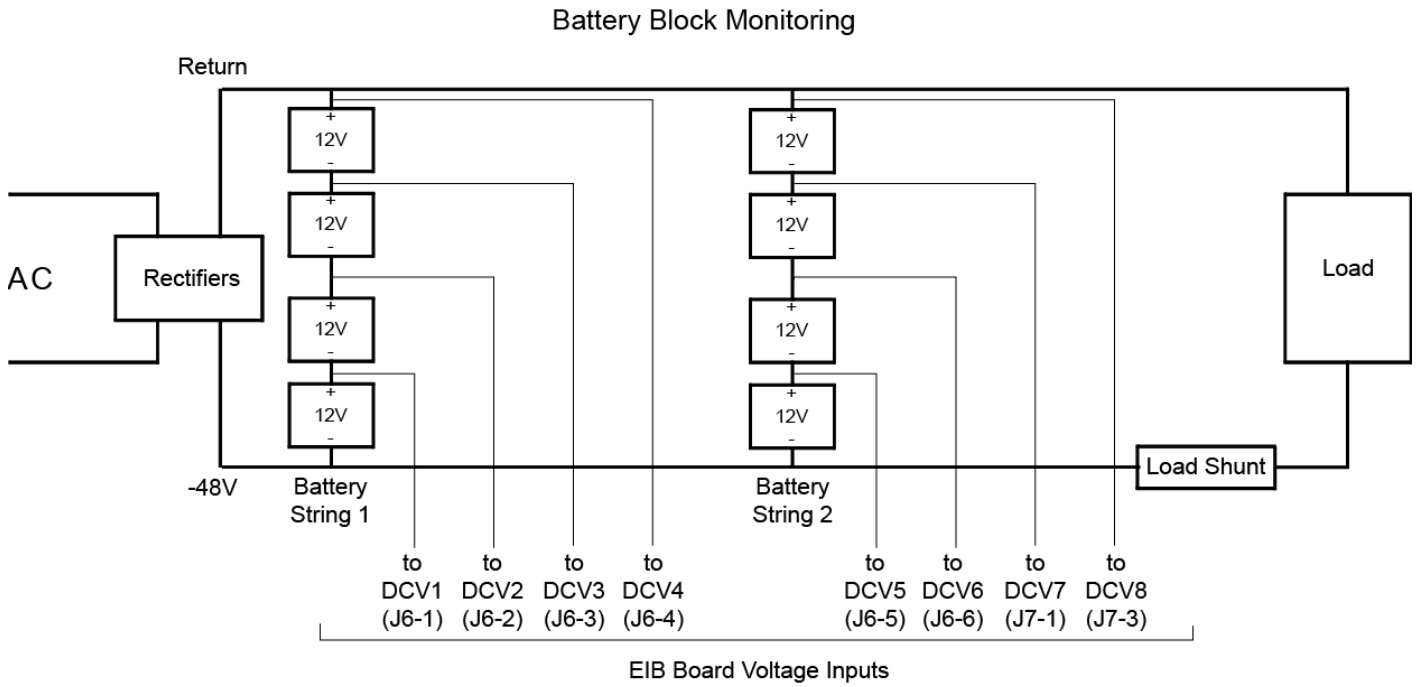
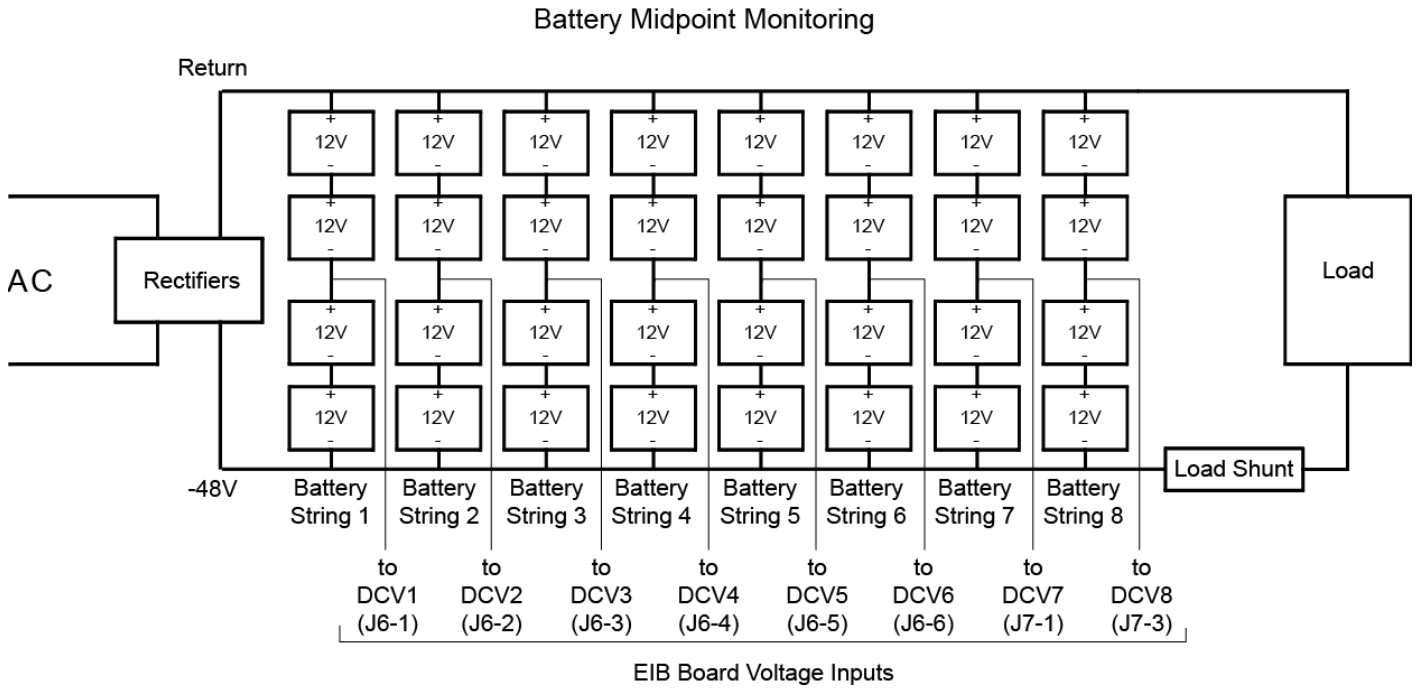


Figure 5.23 Sample Battery Block or Battery Midpoint Monitoring Connections



**Table 5.6 Shunt Inputs – EIB**

Shunt Input	EIB Pin No.		Factory Wiring	Default Function	Customer Defined Function
Sh1	J5-2	+	--	none	
	J5-1	-	--		
Sh2	J5-4	+	--	none	
	J5-3	-	--		
Sh3	J5-6	+	--	none	
	J5-5	-	--		

**Table 5.7 Voltage Inputs – EIB**

Voltage Input	EIB Pin No.	Factory Wiring	Default Function
1	J6-1	--	Battery Block Monitoring
2	J6-2	--	
3	J6-3	--	
4	J6-4	--	
5	J6-5	--	
6	J6-6	--	
7	J7-1	--	
8	J7-3	--	



**NOTE!** The output relay configuration may not be set according to the factory default setting. Refer to the configuration drawing (C-drawing) supplied with your system for your system's specific configuration.

**Table 5.8 Relay Outputs (Factory Default) – EIB**

Programmable Relay Output	EIB Pin No.	541309 Alarm Cable Color Scheme	Factory Wiring	Alarms Assigned to this Relay (Default)	Alarms Assigned to this Relay (Custom)
1	NO	J8-5	W-BL	--	--
	COM	J8-3	BL-W	--	
	NC	J8-1	W-O	--	
2	NO	J8-6	O-W	--	--
	COM	J8-4	W-G	--	
	NC	J8-2	G-W	--	
3	NO	J9-5	W-BR	--	--
	COM	J9-3	BR-W	--	
	NC	J9-1	W-S	--	
4	NO	J9-6	S-W	--	--
	COM	J9-4	R-BL	--	
	NC	J9-2	BL-R	--	
5	NO	J7-6	--	--	Critical Alarm
	COM	J7-4	--	Resistive Battery	
	NC	J7-2	--	Optional Critical Alarm LED	



**CAUTION!** All conductors in this harness may be connected within the cabinet. Shorting or grounding of unused conductors may result in service interruption or equipment damage. Therefore insulate all conductor ends not being used in your application.



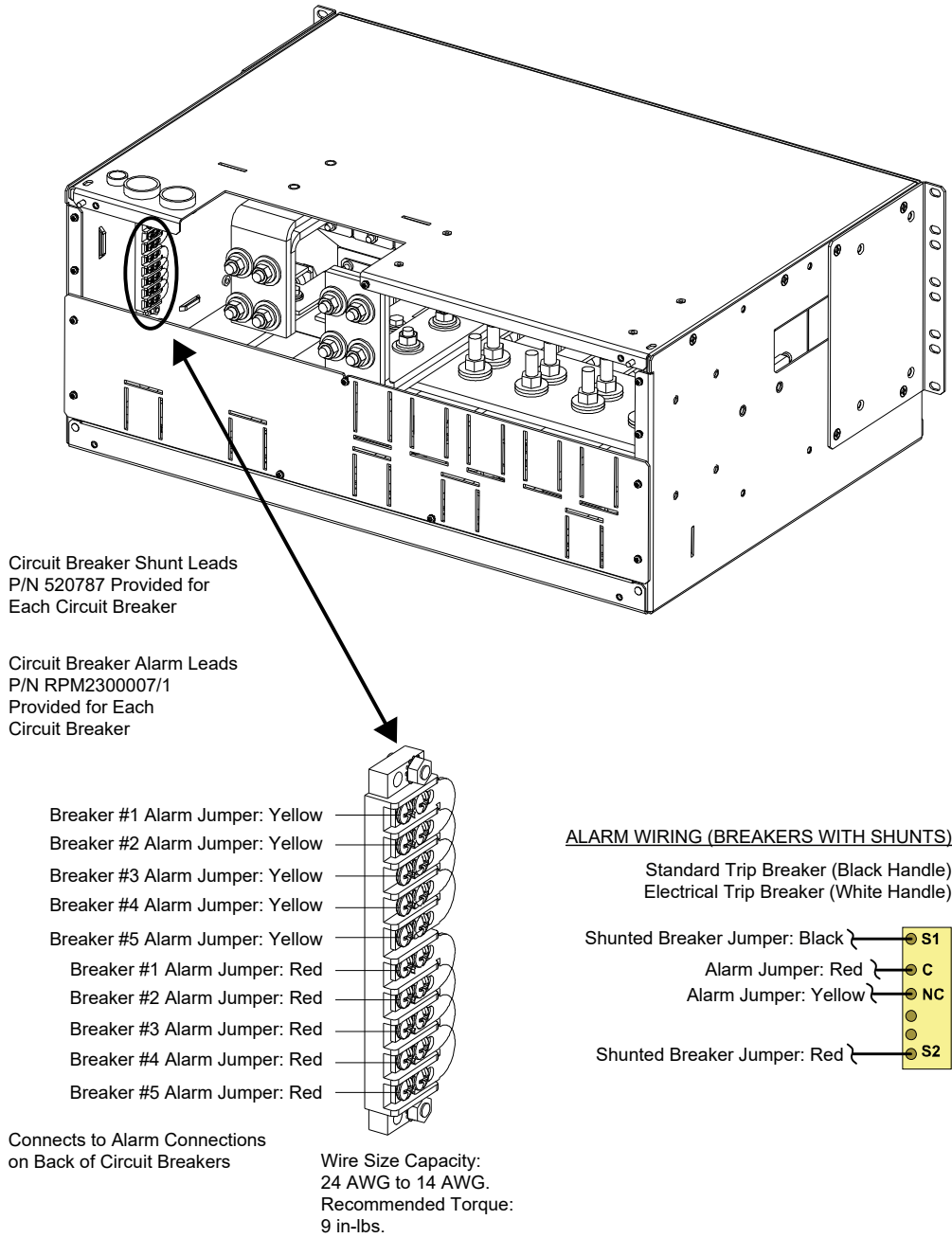
**NOTE!** The relays energize during an alarm condition, closing the contacts between the C and NO terminals, and opening the contacts between the C and NC terminals.

### 5.13.6 Circuit Breaker Alarm and Shunt Monitoring Connections to an Optional List 60 Hybrid Connection Cabinet

#### Circuit Breaker Alarm Connections

Refer to Figure 5.24 for connection details. Torque connections as shown in the illustration.

**Figure 5.24** Circuit Breaker Alarm Connections to an Optional List 60 Hybrid Connection Cabinet

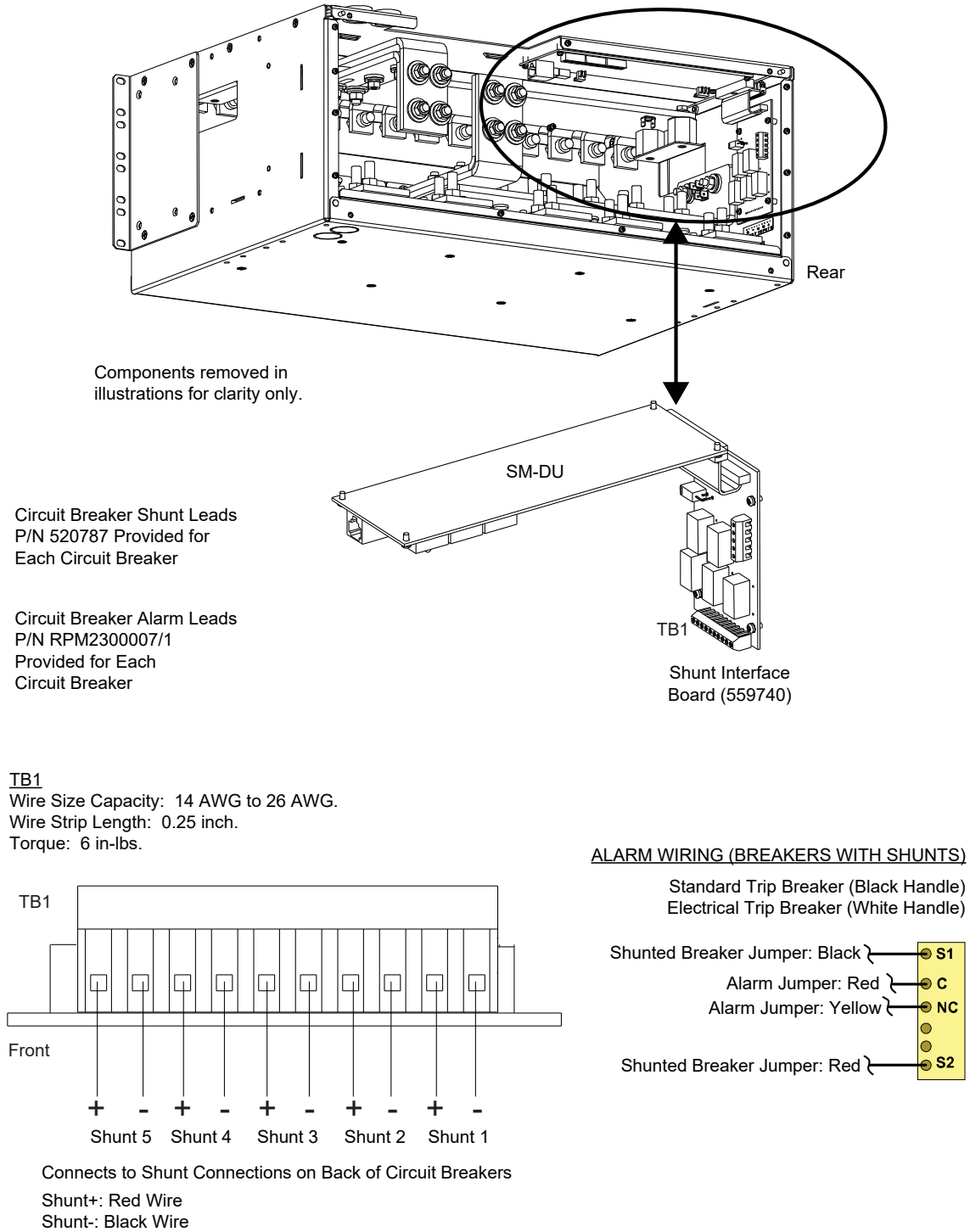




### Shunt Connections

Refer to Figure 5.25 for connection details. Torque connections as shown in the illustration.

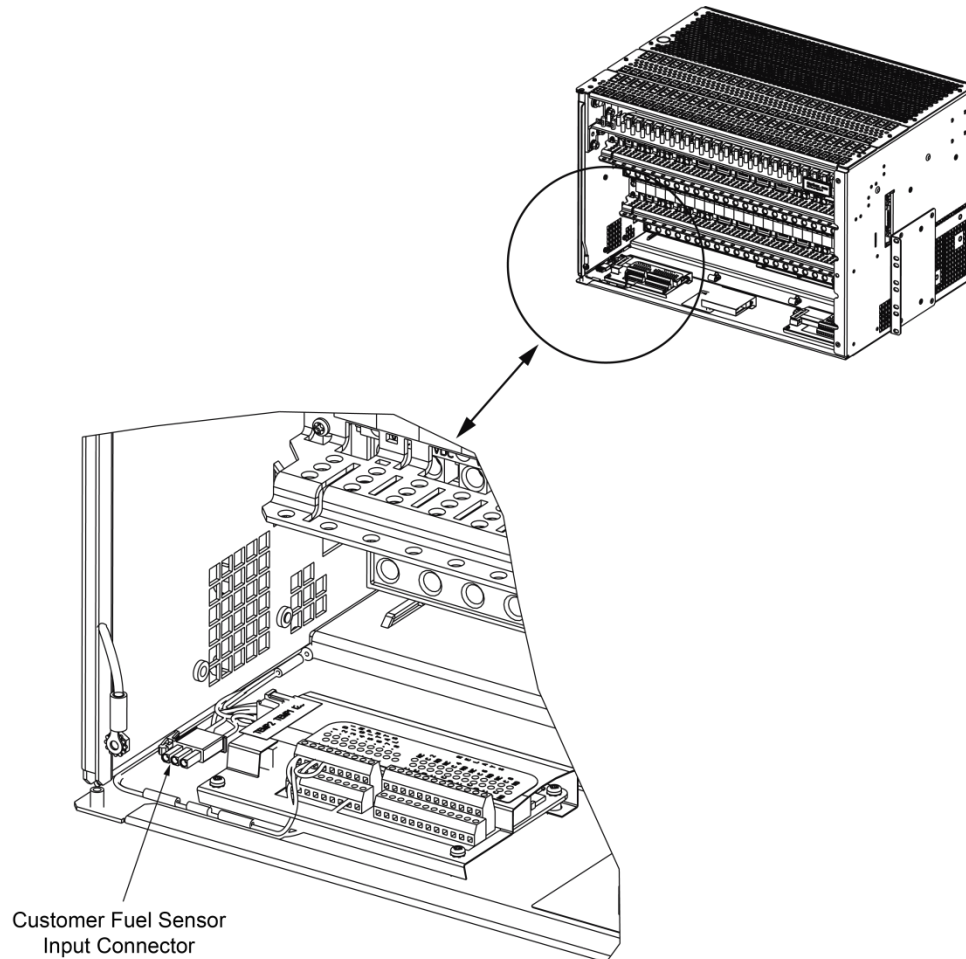
**Figure 5.25 Shunt Connections to an Optional List 60 Hybrid Connection Cabinet**



### 5.13.7 Optional Customer Fuel Sensor Input

A customer fuel sensor input connector is located in the wire harness in front of the bottom row distribution panel. See Figure 5.26 for location and connection details.

**Figure 5.26** Customer Fuel Sensor Input



- Pin 1: Fuel Sensor 1 coming from the controller which is current loop signal (0 mA to 20 mA).
- Pin 2: Sensor return coming from -48 VDC distribution busbar.
- Pin 3: Fuel\_PS, a 12 VDC power supply from the controller to feed the sensor.

Mating Components for Customer Fuel Sensor Input Connector

3-Position Housing: Tyco P/N 172158-1

Pin Terminal: Tyco P/N 170364-1

### 5.13.8 Connecting a Device or System to the NCU CAN Bus (if required)

A supporting device or system may be connected to the NCU CAN Port located inside a distribution cabinet. Refer to Figure 5.19 for location. Refer to Table 5.9 for pin-outs. Refer also to the external device's or system's instruction manual.

#### **General Procedure**

1. Remove the CAN termination plug from the CAN Port connector (see Figure 5.19 for location). Connect the device or system to the NCU Controller's CAN port. Refer to Table 5.9 for pinouts. Ensure that the last device on the controller's CAN bus has a CAN termination plug. Refer also to the external device's or system's instruction manual.

#### **Optional SM-Temp Module Procedure**

The analog output of the SM-Temp Module may be connected to an NCU temperature port input. In lieu of connecting the analog output of the SM-TEMP module to an NCU temperature port input, the SM-TEMP module can simply be connected at the end of the NCU CAN bus. Refer to the SM-Temp Module Instructions (UM547490) for details.

#### Connecting the SM-Temp Module to the Controller's CAN Bus

1. Remove the CAN termination plug from the CAN Port connector (see Figure 5.19 for location). Connect the SM-Temp Module CAN bus to the CAN Port connector using separately ordered SM-Temp CAN bus interface cable (P/N 562868). Refer to Table 5.9 for pinouts. Ensure the last SM-Temp Module (or if only one) has a CAN termination strap as shown in the SM-Temp Module Instructions (UM547490).

**Table 5.9 CAN Port Connections**

NCU CAN Port (RJ-45)		SM-Temp Module CAN Port Pin Number
Pin Number	Function	
1	CAN L	TB1-5 (CAN L)
2	CAN H	TB1-3 (CAN H)
3	--	--
4	--	--
5	--	--
6	--	--
7	--	--
8	--	--

### 5.14 NCU Controller Ethernet Connection (if required)

The NCU Controller provides a Web Interface via an Ethernet connection to a TCP/IP network. This interface can be accessed locally on a computer or remotely through a network. An RJ-45 10BaseT jack is provided on the front of the NCU for connection into a customer's network. This jack has a standard Ethernet pin configuration scheme, twisted pair. Refer to Figure 5.27 and for location and Table 5.10 for pin outs. Use shielded Ethernet cable (grounded at both ends). Note that the NCU RJ-45 jack is connected to chassis ground. Refer to the NCU Instructions (UM1M830BNA) for operational details.



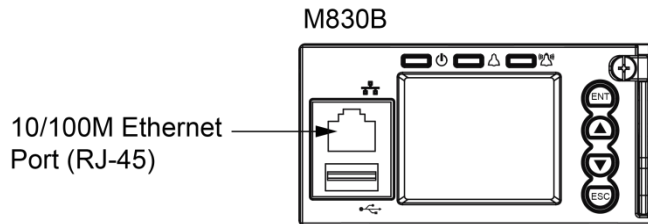
**NOTE!** You can access the Web pages of the power system locally by using a "crossover" or "straight" cable connected directly between your PC and the NCU.



**WARNING!** The intra-building port(s) of the equipment or subassembly is suitable for connection to intra-building or unexposed wiring or cabling only. The intra-building port(s) of the equipment or subassembly **MUST NOT** be metalically connected to the interfaces that connect to the OSP or its wiring. These interfaces are designed for use as intra-building interfaces only (Type 2 or Type 4 ports as described in GR-1089-CORE, Issue 4) and require isolation from the exposed OSP cabling. The addition of Primary Protectors is not sufficient protection in order to connect these interfaces metalically to OSP wiring.

The intra-building port (RJ-45) of the equipment or subassembly must use shielded intra-building cabling/wiring that is grounded at both ends.

**Figure 5.27 NCU Ethernet Port**



**NOTE!** If your system has an IB4 board, **DO NOT** connect your Local Area Network (LAN) to the NCU front Ethernet port. See “NCU Controller Second Ethernet Port Connection (if IB4 board furnished)” on page 116.

**Table 5.10 NCU RJ-45 Ethernet Port Pin Configuration**

Port Pin Number	Name	Definition
1	Tx+	Write Signal +
2	Tx-	Write Signal -
3	Rx+	Read Signal +
4	--	no connection
5	--	no connection
6	Rx-	Read Signal -
7	--	no connection
8	--	no connection

### **NCU Controller Second Ethernet Port Connection (if IB4 board furnished)**

Your system may be furnished with an IB4 board connected to the NCU backplane via a factory furnished and connected cable. The IB4 board provides a second Ethernet port. The Ethernet port located on the NCU Controller’s front panel can **ONLY** be used to connect a computer directly to the NCU. The Ethernet port located on the IB4 board can be used to connect the NCU to your Local Area Network (LAN).



**NOTE!** If your system has an IB4 board, **DO NOT** connect your Local Area Network (LAN) to the NCU front Ethernet port.

An RJ-45 10BaseT jack is provided on the IB4 board for connection into a customer's network. This jack has a standard Ethernet pin configuration scheme, twisted pair. Refer to Figure 5.28 for location and Table 5.10 for pin outs. Use shielded Ethernet cable (grounded at both ends). Note that the IB4 board’s RJ-45 jack is connected to chassis ground. Refer to the NCU Instructions (UM1M830BNA) for operational details.

**Default IB4 Ethernet Port Parameters**IPv4

IP Address: 192.168.1.2  
 Subnet Mask: 255.255.255.0  
 Default Gateway: 192.168.1.1

IPv6

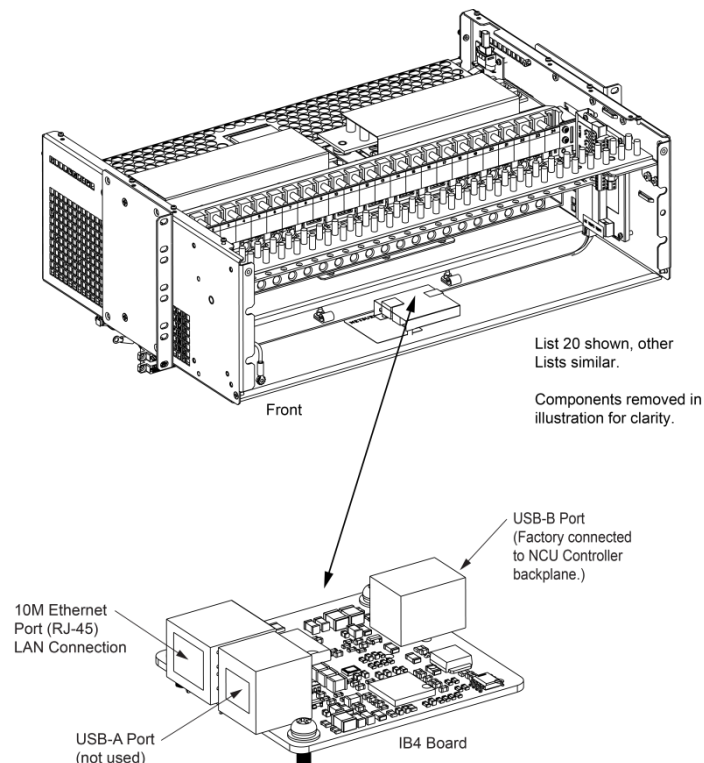
IPv6 Address: 20fa:fffd:fffc:fffb:ffa:fff9:fff8:fff7  
 IPv6 Prefix: 0  
 IPv6 Gateway: 20fa:1:ffff:ffff:fffd:ffff:fffe



**WARNING!** The intra-building port(s) of the equipment or subassembly is suitable for connection to intra-building or unexposed wiring or cabling only. The intra-building port(s) of the equipment or subassembly **MUST NOT** be metallically connected to the interfaces that connect to the OSP or its wiring. These interfaces are designed for use as intra-building interfaces only (Type 2 or Type 4 ports as described in GR-1089-CORE, Issue 4) and require isolation from the exposed OSP cabling. The addition of Primary Protectors is not sufficient protection in order to connect these interfaces metallically to OSP wiring.

The intra-building port (RJ-45) of the equipment or subassembly must use shielded intra-building cabling/wiring that is grounded at both ends.

**Figure 5.28 IB4 Board NCU Controller Second Ethernet Port**



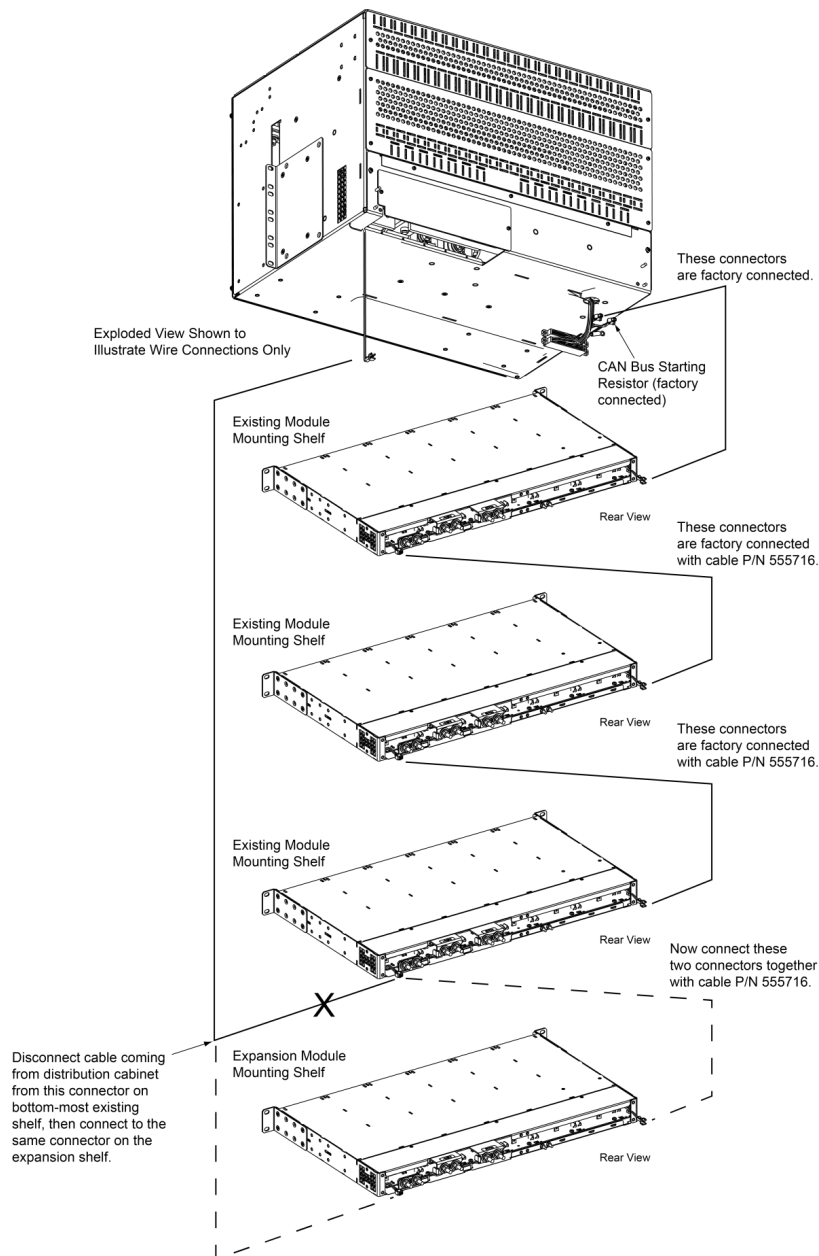
## 5.15 Control Bus Connections between Controller and Module Mounting Assemblies

### General

Each module mounting assembly in the system is daisy-chained to the controller. NCU CAN bus connectors are located at the left and right rear of each module mounting assembly. These connectors are used to interconnect the module mounting assemblies to the controller and to other module mounting assemblies.

The right side module mounting assembly NCU CAN bus connector is factory jumpered so both connectors can be accessed from the left side of the module mounting assembly. Refer to Figure 5.29 for connector locations and an interconnect diagram. These connections are factory made for module mounting assemblies factory installed. For field expansion, the new module mounting assembly must be tied into the interconnect scheme as shown in Power System User Instructions UM582137100.

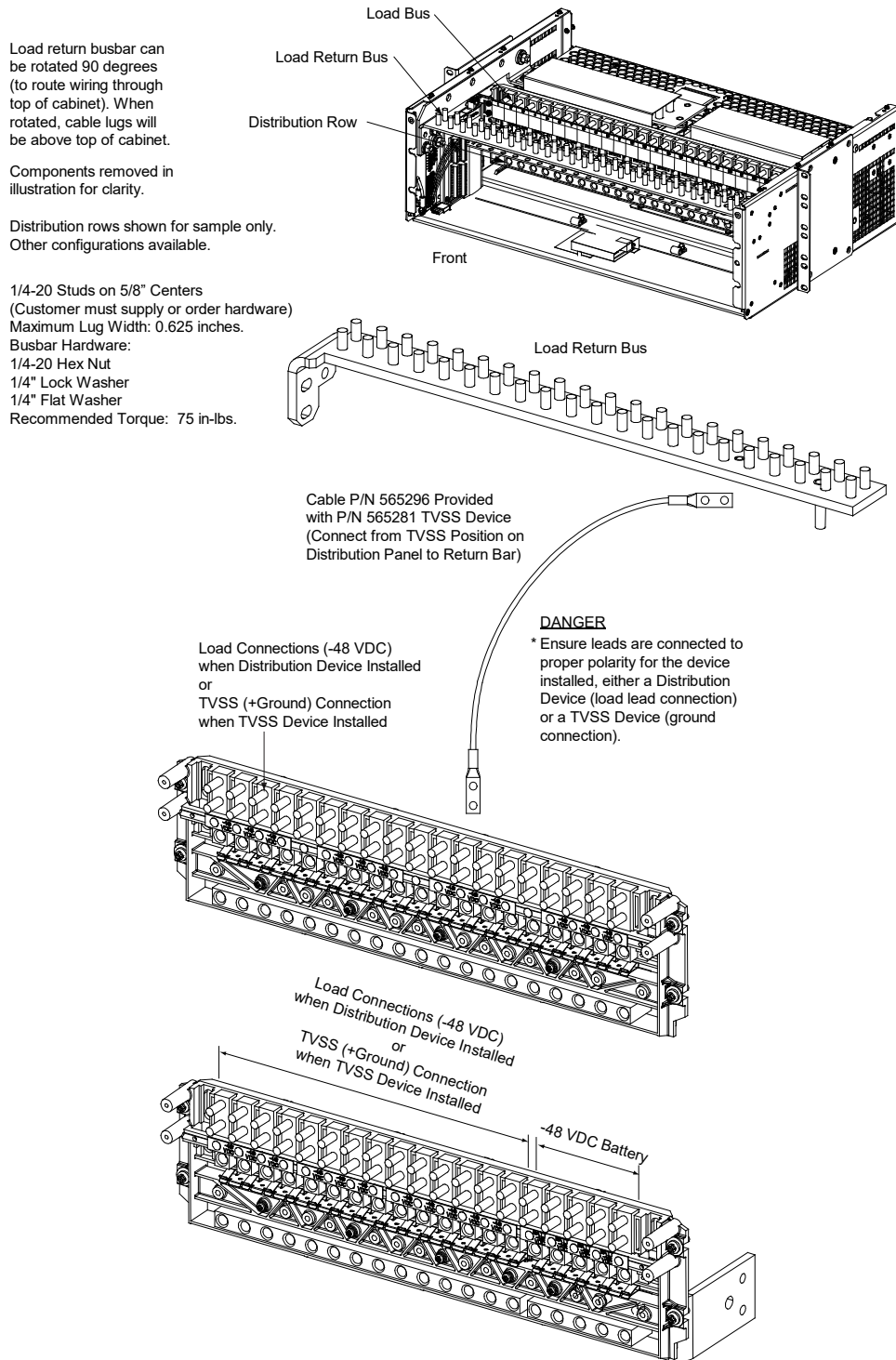
**Figure 5.29 Control Bus Connections between Controller and Module Mounting Assemblies**



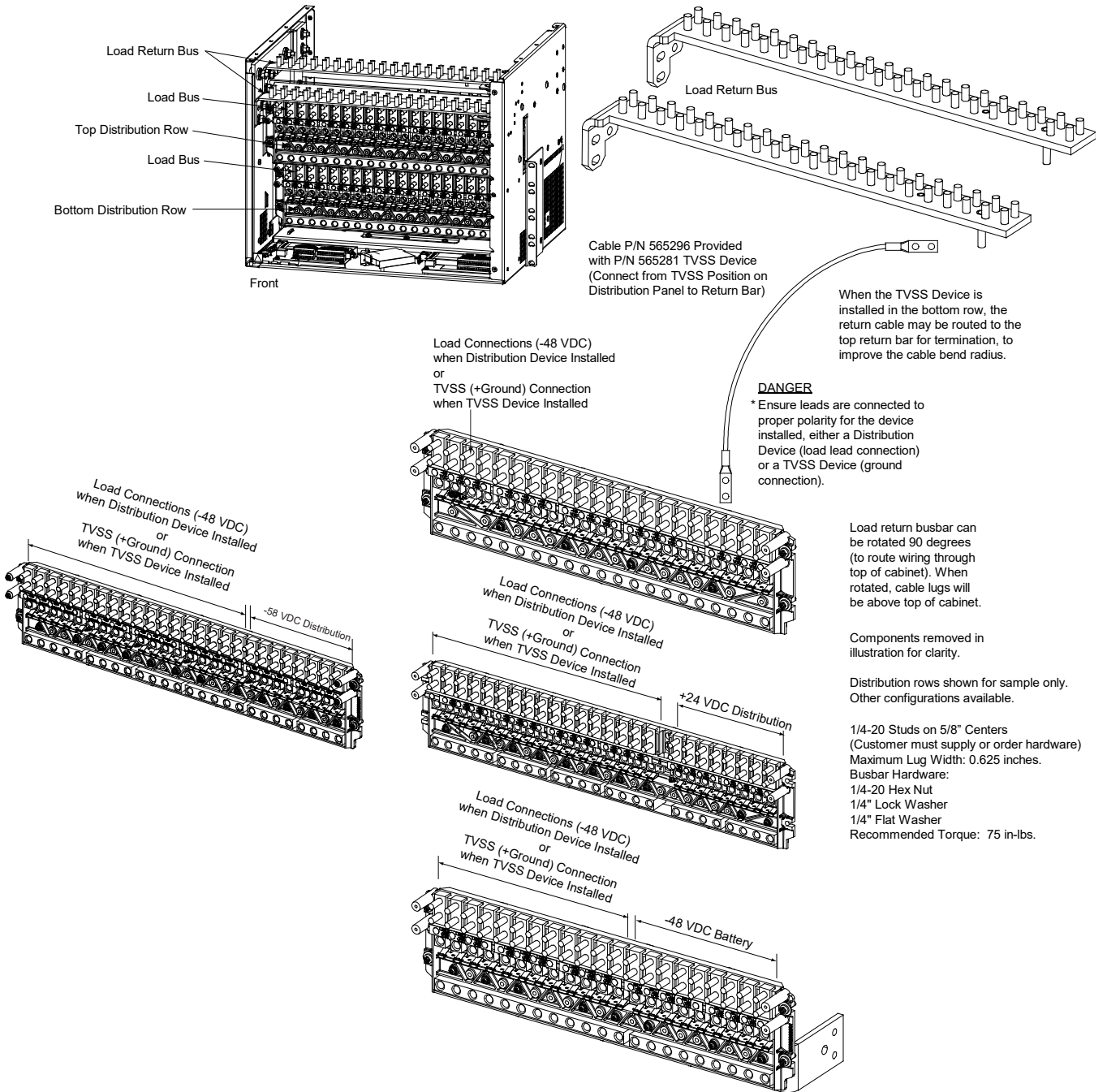
## 5.16 Optional Transient Voltage Surge Suppressor (TVSS) Device Ground Connection

Connect cable P/N 565296 (provided with P/N 565281 TVSS device) from the TVSS position on the distribution panel to the return bar. Refer to Figure 5.30, Figure 5.31, and Figure 5.32.

**Figure 5.30 582137100 List 20, List 25 Distribution Cabinet Optional Transient Voltage Surge Suppressor (TVSS) Device Ground Connection**



**Figure 5.31 582137100 List 21, List 26 Distribution Cabinet Optional Transient Voltage Surge Suppressor (TVSS) Device Ground Connection**





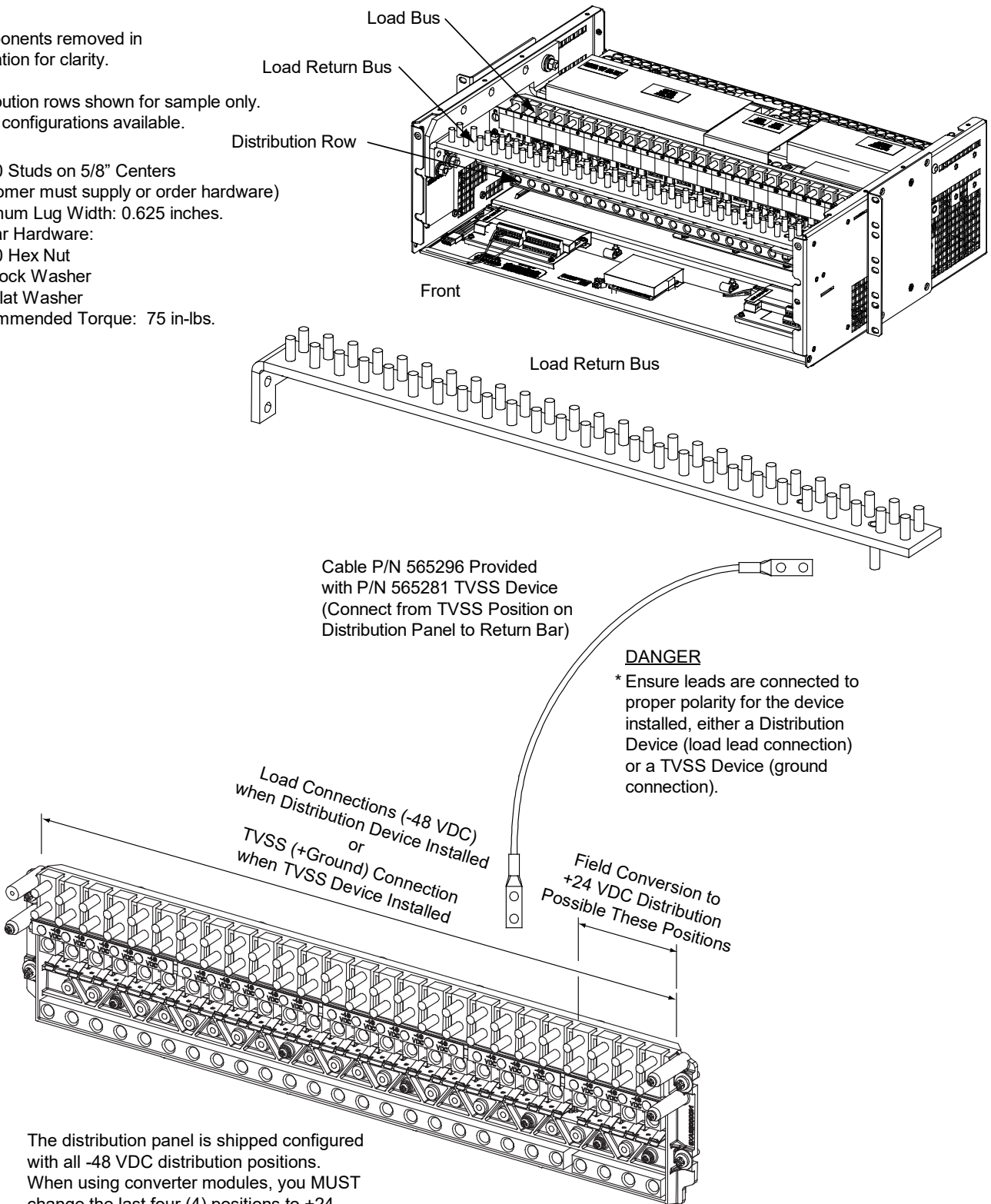
**Figure 5.32 582137100 List 27 Distribution Cabinet Optional Transient Voltage Surge Suppressor (TVSS) Device Ground Connection**

Components removed in illustration for clarity.

Distribution rows shown for sample only. Other configurations available.

1/4-20 Studs on 5/8" Centers  
(Customer must supply or order hardware)

Maximum Lug Width: 0.625 inches.  
Busbar Hardware:  
1/4-20 Hex Nut  
1/4" Lock Washer  
1/4" Flat Washer  
Recommended Torque: 75 in-lbs.



The distribution panel is shipped configured with all -48 VDC distribution positions. When using converter modules, you MUST change the last four (4) positions to +24 VDC distribution positions in the field. Refer to UM582137100 for a procedure.

## 5.17 Load Connections

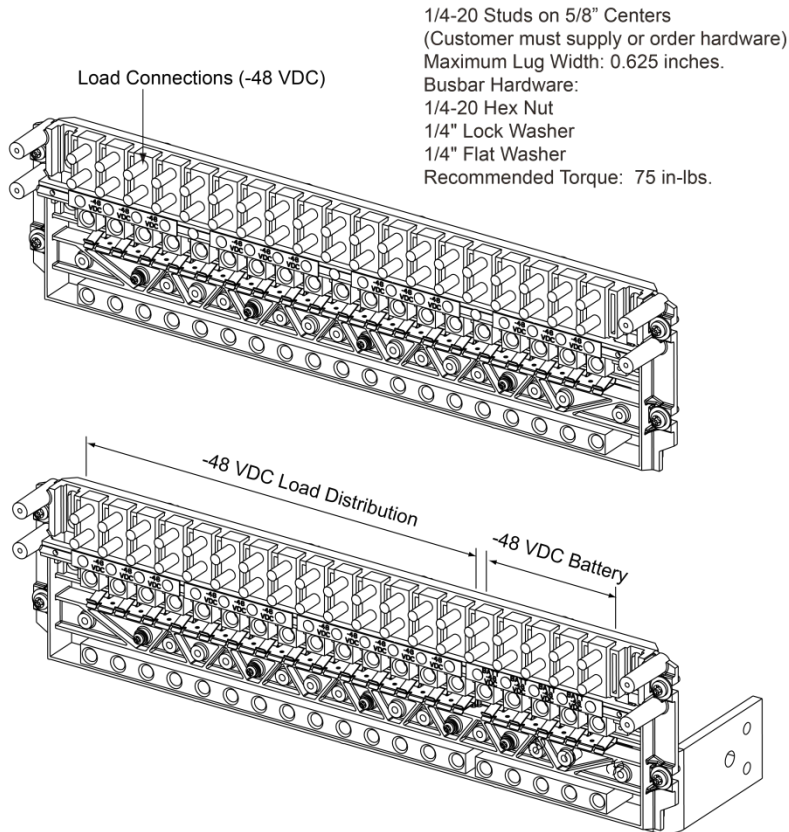
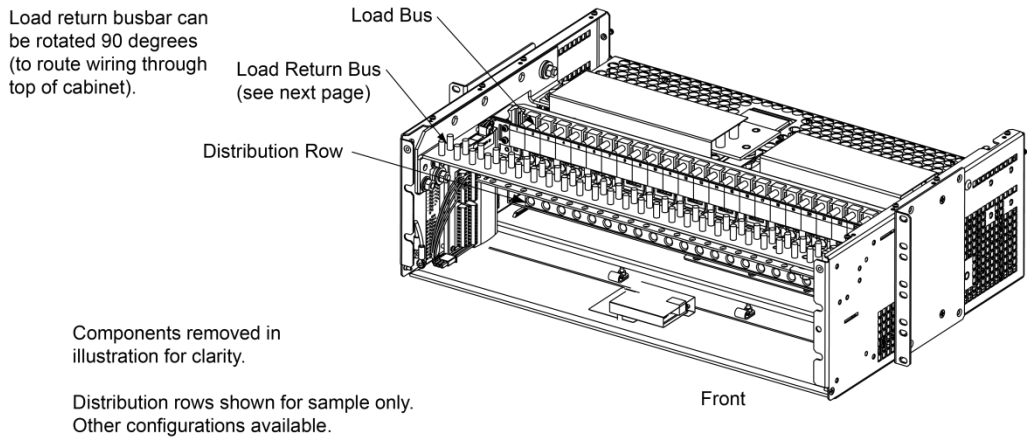
### 5.17.1 Load Connections to a List 20, 25 Distribution Cabinet

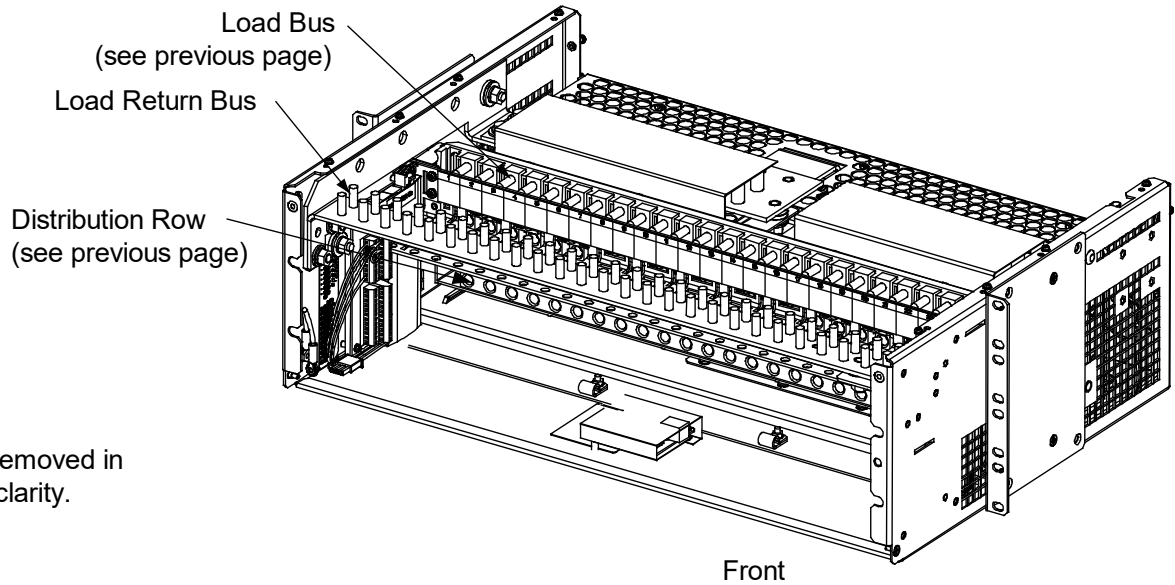


**WARNING!** Observe proper polarity when making load connections.

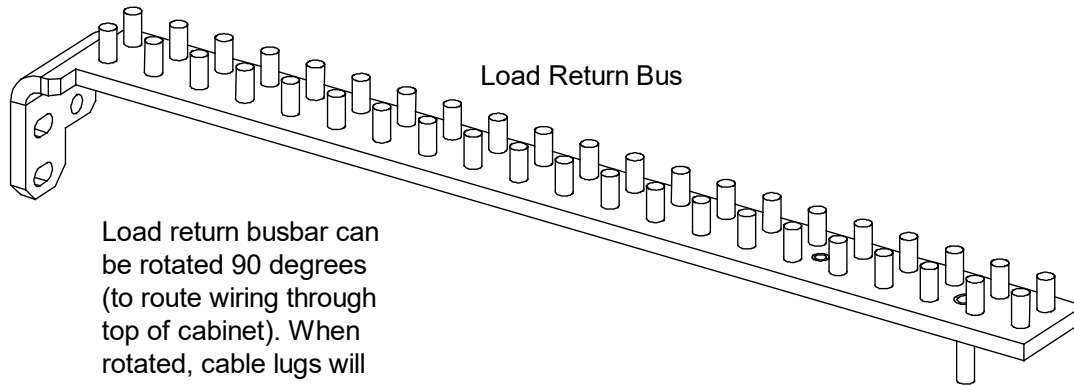
Load leads are connected to the individual load busbars located on the distribution panel (refer to Figure 5.33). Load return leads are connected to the return busbar located at the top of the distribution cabinet (refer to Figure 5.34). Refer to Figure 5.35 through Figure 5.39 for illustrations of the available distribution panels. Torque connections as shown in the illustrations.

**Figure 5.33 Load Side Connections in a List 20, 25 Distribution Cabinet**



**Figure 5.34** Load Return Side Connections in a List 20, 25 Distribution Cabinet

Components removed in illustration for clarity.



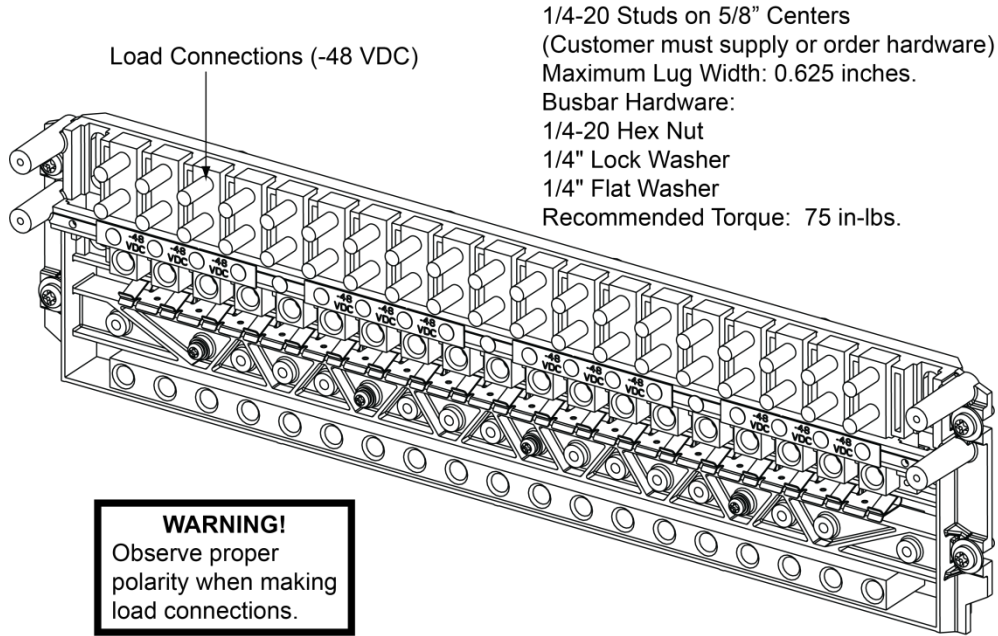
Load return busbar can be rotated 90 degrees (to route wiring through top of cabinet). When rotated, cable lugs will be above top of cabinet.

1/4-20 Studs on 5/8" Centers  
(Customer must supply or order hardware)  
Maximum Lug Width: 0.625 inches.  
Busbar Hardware:  
1/4-20 Hex Nut  
1/4" Lock Washer  
1/4" Flat Washer  
Recommended Torque: 75 in-lbs.

### Load Connections to Single Voltage Distribution Panels in a List 20, 25 Distribution Cabinet

Figure 5.35 List AN Load Connections in a List 20 Distribution Cabinet

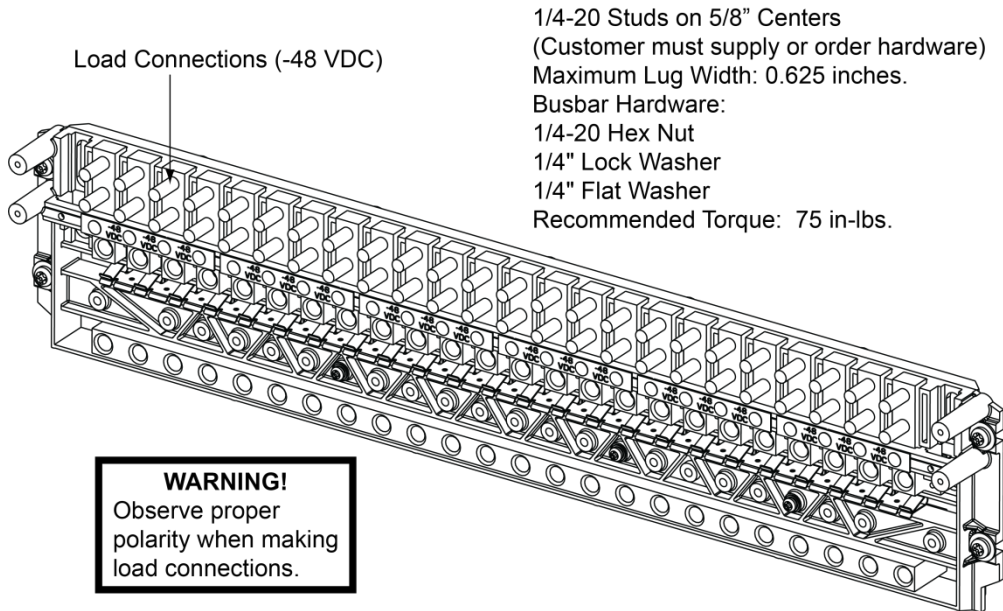
(19) -48 VDC Load Bullet/TPS/TLS Circuit Breaker/Fuse Positions



See SAG582137100 for temperature, sizing, and spacing restrictions.

Figure 5.36 List AA Load Connections in a List 25 Distribution Cabinet

(24) -48 VDC Load Bullet/TPS/TLS Circuit Breaker/Fuse Positions

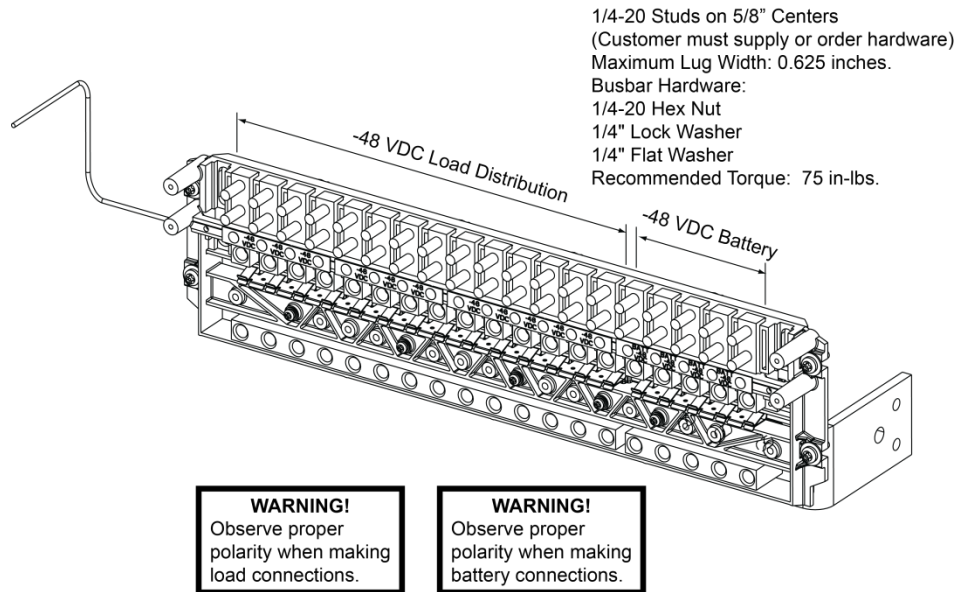


See SAG582137100 for temperature, sizing, and spacing restrictions.

**Load Connections to Single Voltage Plus Battery Disconnect Distribution Panels in a List 20, 25 Distribution Cabinet**

**Figure 5.37** List BN Load Connections in a List 20 Distribution Cabinet

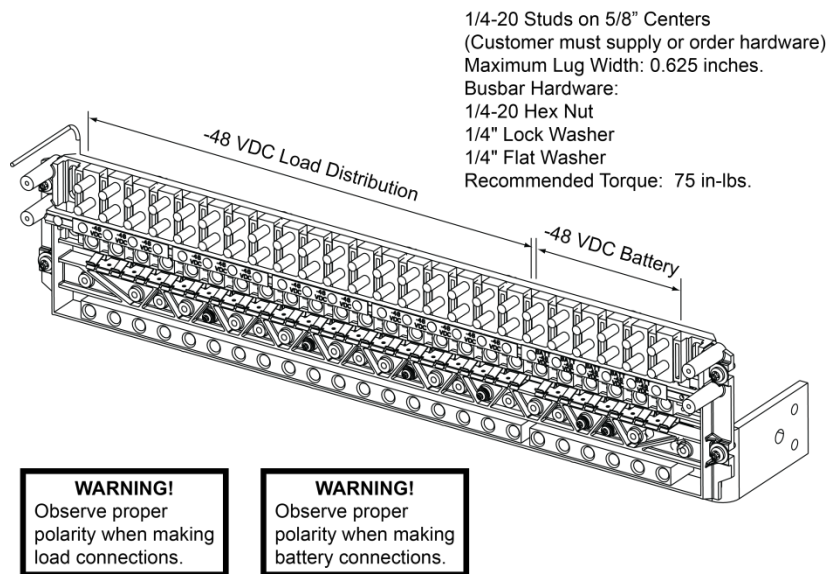
- (14) -48 VDC Load Bullet/TPS/TLS Circuit Breaker/Fuse Positions and
- (5) -48 VDC Battery Disconnect Bullet/TPS/TLS Circuit Breaker/Fuse Positions



See SAG582137100 for temperature, sizing, and spacing restrictions.

**Figure 5.38** List BA Load Connections in a List 25 Distribution Cabinet

- (18) -48 VDC Load Bullet/TPS/TLS Circuit Breaker/Fuse Positions and
- (6) -48 VDC Battery Disconnect Bullet/TPS/TLS Circuit Breaker/Fuse Positions

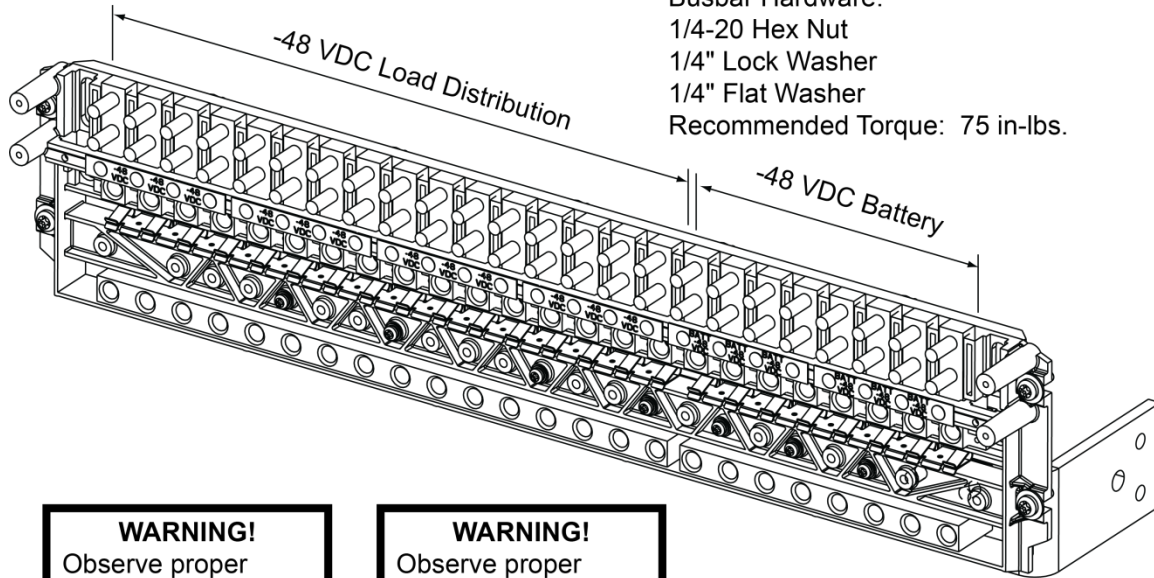


See SAG582137100 for temperature, sizing, and spacing restrictions.

**Figure 5.39** List BC Load Connections in a List 25 Distribution Cabinet

- (16) -48 VDC Load Bullet/TPS/TLS Circuit Breaker/Fuse Positions and
- (8) -48 VDC Battery Disconnect Bullet/TPS/TLS Circuit Breaker/Fuse Positions

1/4-20 Studs on 5/8" Centers  
(Customer must supply or order hardware)  
Maximum Lug Width: 0.625 inches.  
Busbar Hardware:  
1/4-20 Hex Nut  
1/4" Lock Washer  
1/4" Flat Washer  
Recommended Torque: 75 in-lbs.



**WARNING!**  
Observe proper polarity when making load connections.

**WARNING!**  
Observe proper polarity when making battery connections.

See SAG582137100 for temperature, sizing, and spacing restrictions.

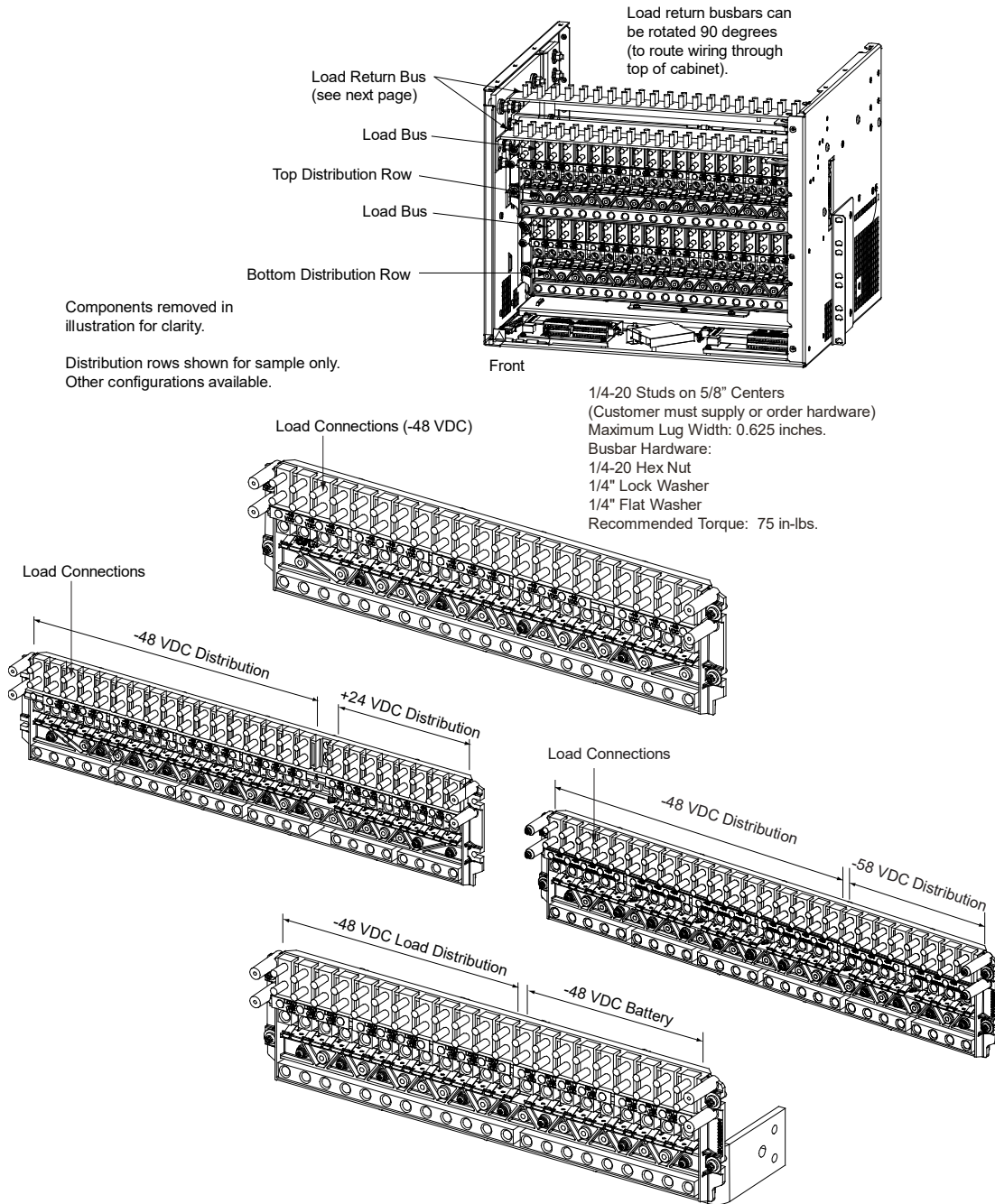
### 5.17.2 Load Connections to a List 21, 26 Distribution Cabinet



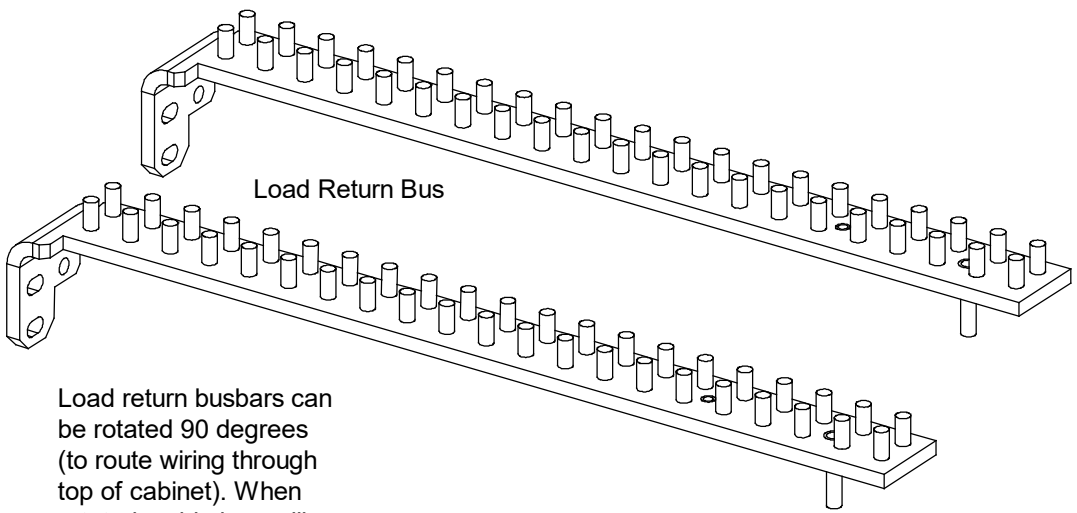
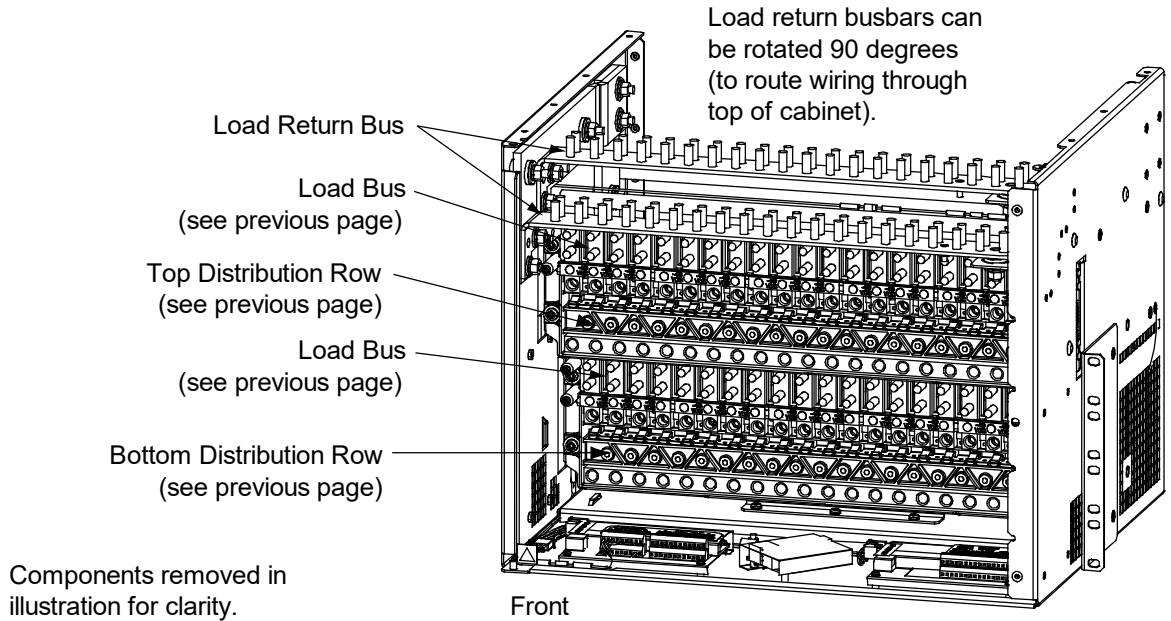
**WARNING!** Observe proper polarity when making output connections.

Load leads are connected to the individual load busbars located on the distribution panels (refer to Figure 5.40). Load return leads are connected to separate return busbars located at the top of the distribution cabinet (refer to Figure 5.41). Refer to Figure 5.42 through Figure 5.58 for illustrations of the available distribution panels. Torque connections as shown in the illustrations.

**Figure 5.40 Load Side Connections in a List 21, 26 Distribution Cabinet**



**Figure 5.41 Load Return Side Connections in a List 21, 26 Distribution Cabinet**



Load return busbars can be rotated 90 degrees (to route wiring through top of cabinet). When rotated, cable lugs will be above top of cabinet.

- 1/4-20 Studs on 5/8" Centers
- (Customer must supply or order hardware)
- Maximum Lug Width: 0.625 inches.
- Busbar Hardware:
- 1/4-20 Hex Nut
- 1/4" Lock Washer
- 1/4" Flat Washer
- Recommended Torque: 75 in-lbs.

Note: If you have a larger cable, use the lug adapter kits as follows and connect the flat busbar adapter piece to the top return bar:

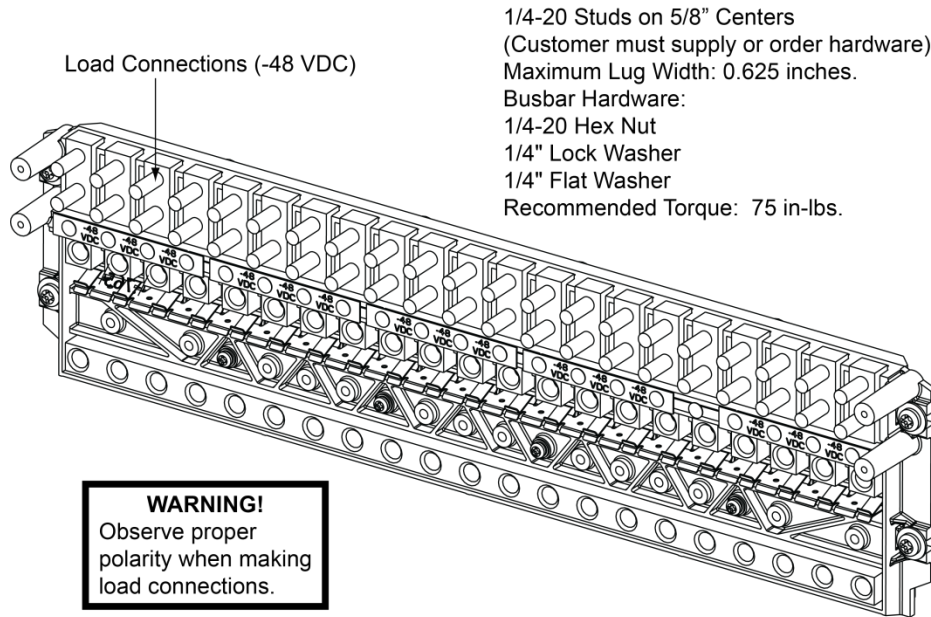
<u>Rear Feed</u>	<u>Top Feed</u>
2-pole - 559804	2-pole - 563191
3-pole - 559805	3-pole - 563193

You could also use the "Special Application Crimp Lug/Strap Combination" listed in SAG582137100 and connect to either return bar.



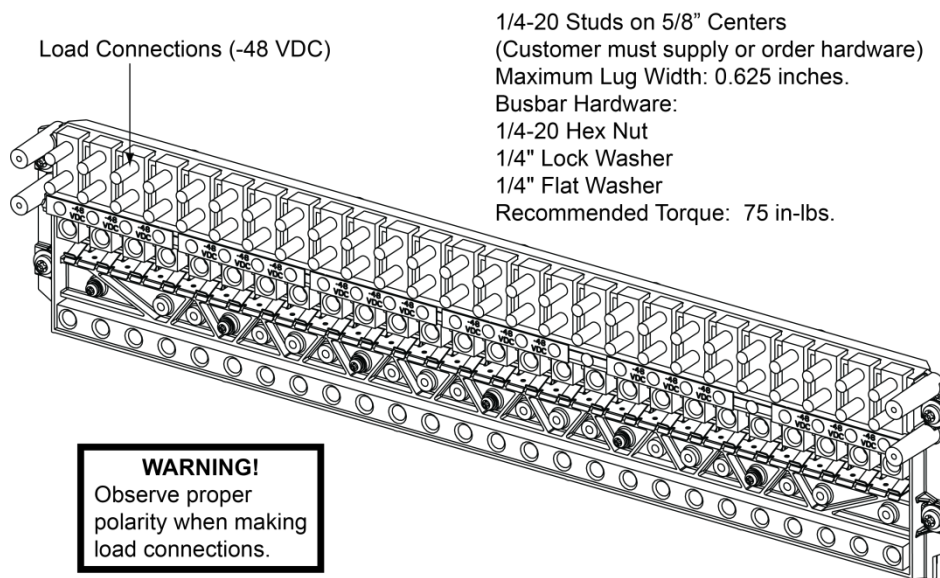
## Load Connections to Single Voltage Distribution Panels in a List 21, 26 Distribution Cabinet

**Figure 5.42** List AO Load Connections in a List 21 Distribution Cabinet  
(21) -48 VDC Load Bullet/TPS/TLS Circuit Breaker/Fuse Positions



See SAG582137100 for temperature, sizing, and spacing restrictions.

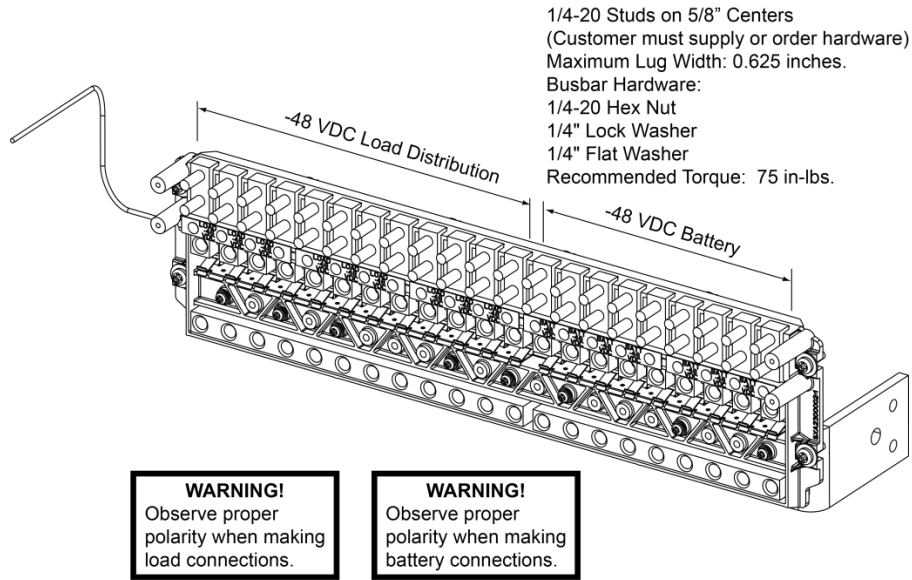
**Figure 5.43** List AB Load Connections in a List 26 Distribution Cabinet  
(26) -48 VDC Load Bullet/TPS/TLS Circuit Breaker/Fuse Positions



See SAG582137100 for temperature, sizing, and spacing restrictions.

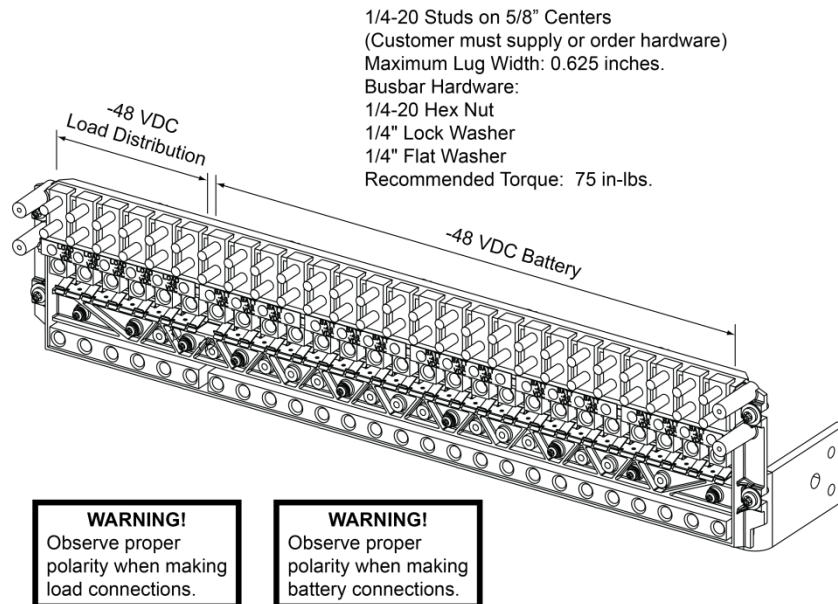
**Load Connections to Single Voltage Plus Battery Disconnect Distribution Panels in a List 21, 26 Distribution Cabinet**

**Figure 5.44** List BO Load Connections in a List 21 Distribution Cabinet  
 (12) -48 VDC Load Bullet/TPS/TLS Circuit Breaker/Fuse Positions and  
 (9) -48 VDC Battery Disconnect Bullet/TPS/TLS Circuit Breaker/Fuse Positions



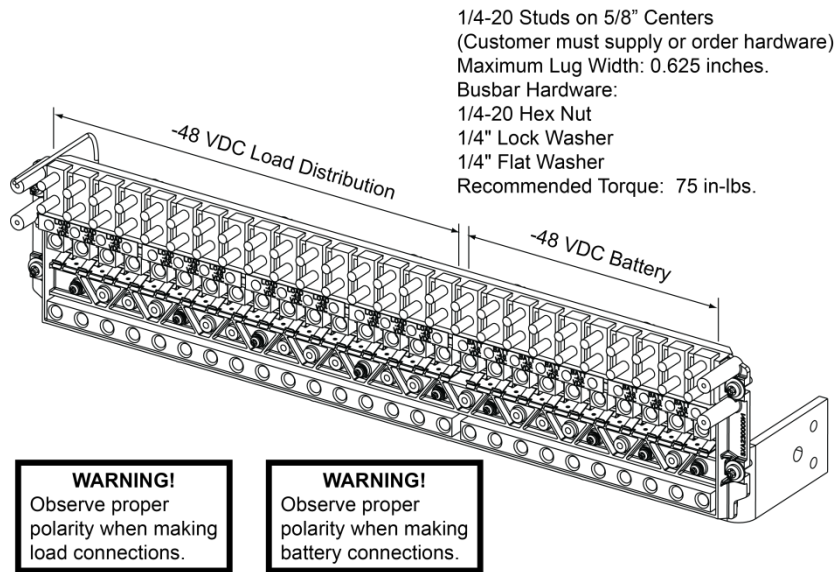
See SAG582137100 for temperature, sizing, and spacing restrictions.

**Figure 5.45** List BB Load Connections in a List 26 Distribution Cabinet  
 (6) -48 VDC Load Bullet/TPS/TLS Circuit Breaker/Fuse Positions and  
 (20) -48 VDC Battery Disconnect Bullet/TPS/TLS Circuit Breaker/Fuse Positions



See SAG582137100 for temperature, sizing, and spacing restrictions.

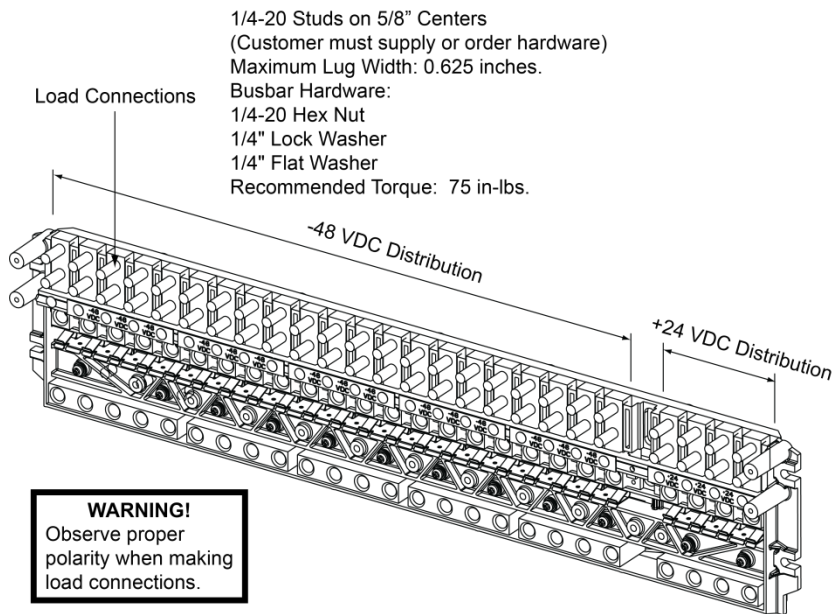
**Figure 5.46** List BD Load Connections in a List 26 Distribution Cabinet  
 (16) -48 VDC Load Bullet/TPS/TLS Circuit Breaker/Fuse Positions and  
 (10) -48 VDC Battery Disconnect Bullet/TPS/TLS Circuit Breaker/Fuse Positions



See SAG582137100 for temperature, sizing, and spacing restrictions.

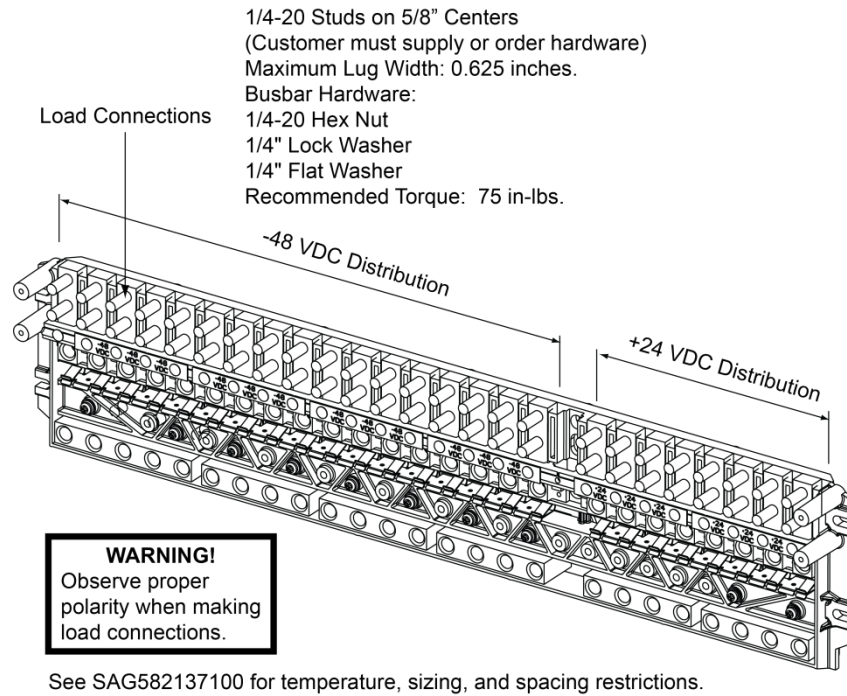
**Load Connections to Dual Voltage Distribution Panels in a List 26 Distribution Cabinet**

**Figure 5.47** List DA Load Connections in a List 26 Distribution Cabinet  
 (21) -48 VDC Load Bullet/TPS/TLS Circuit Breaker/Fuse Positions and  
 (4) +24 VDC Load Bullet/TPS/TLS Circuit Breaker/Fuse Positions

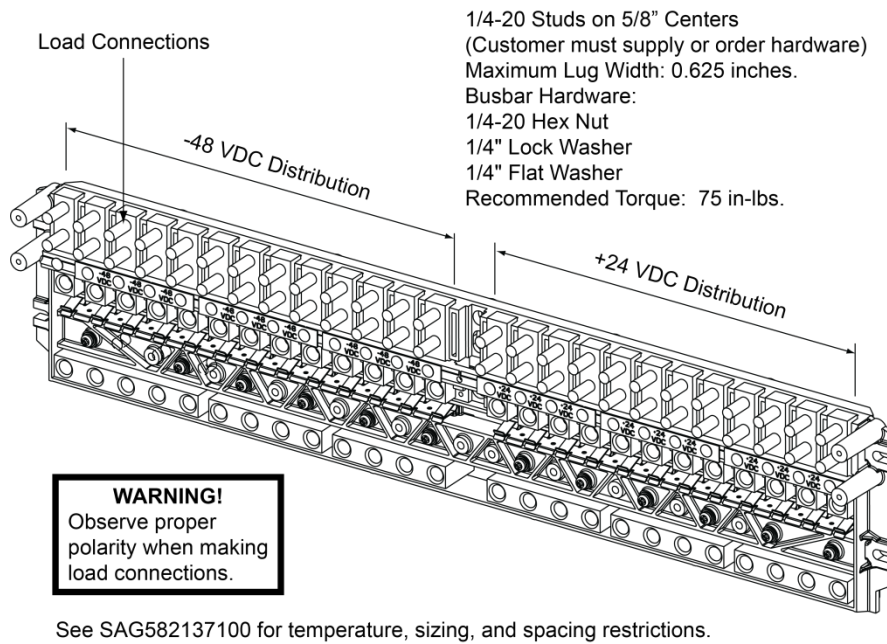


See SAG582137100 for temperature, sizing, and spacing restrictions.

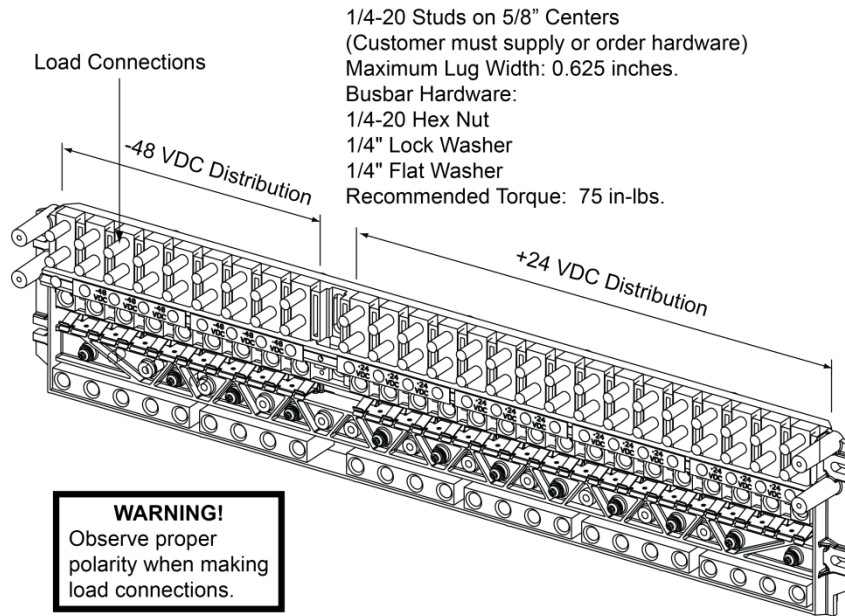
**Figure 5.48** List DB Load Connections in a List 26 Distribution Cabinet  
 (17) -48 VDC Load Bullet/TPS/TLS Circuit Breaker/Fuse Positions and  
 (8) +24 VDC Load Bullet/TPS/TLS Circuit Breaker/Fuse Positions



**Figure 5.49** List DC Load Connections in a List 26 Distribution Cabinet  
 (13) -48 VDC Load Bullet/TPS/TLS Circuit Breaker/Fuse Positions and  
 (12) +24 VDC Load Bullet/TPS/TLS Circuit Breaker/Fuse Positions

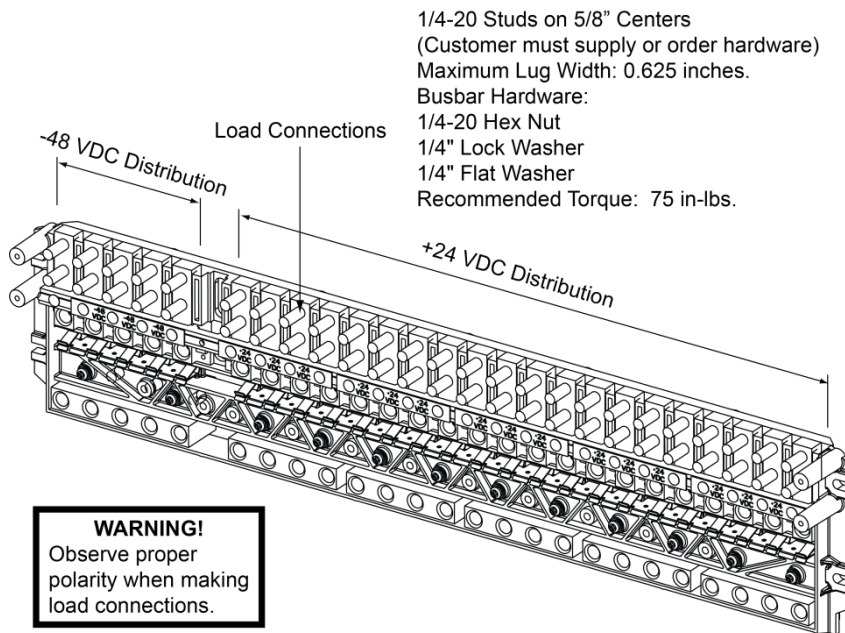


**Figure 5.50** List DD Load Connections in a List 26 Distribution Cabinet  
 (9) -48 VDC Load Bullet/TPS/TLS Circuit Breaker/Fuse Positions and  
 (16) +24 VDC Load Bullet/TPS/TLS Circuit Breaker/Fuse Positions



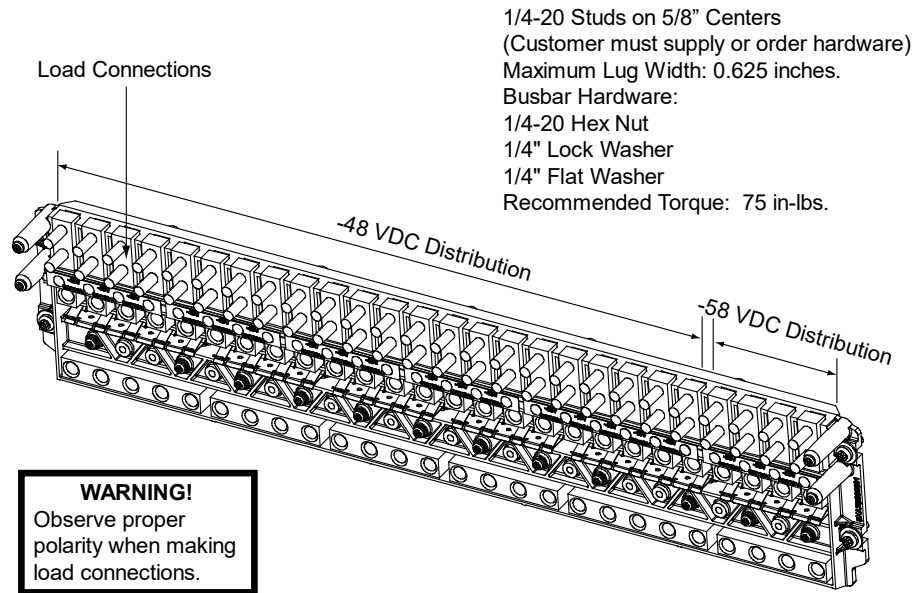
See SAG582137100 for temperature, sizing, and spacing restrictions.

**Figure 5.51** List DE Load Connections in a List 26 Distribution Cabinet  
 (5) -48 VDC Load Bullet/TPS/TLS Circuit Breaker/Fuse Positions and  
 (20) +24 VDC Load Bullet/TPS/TLS Circuit Breaker/Fuse Positions



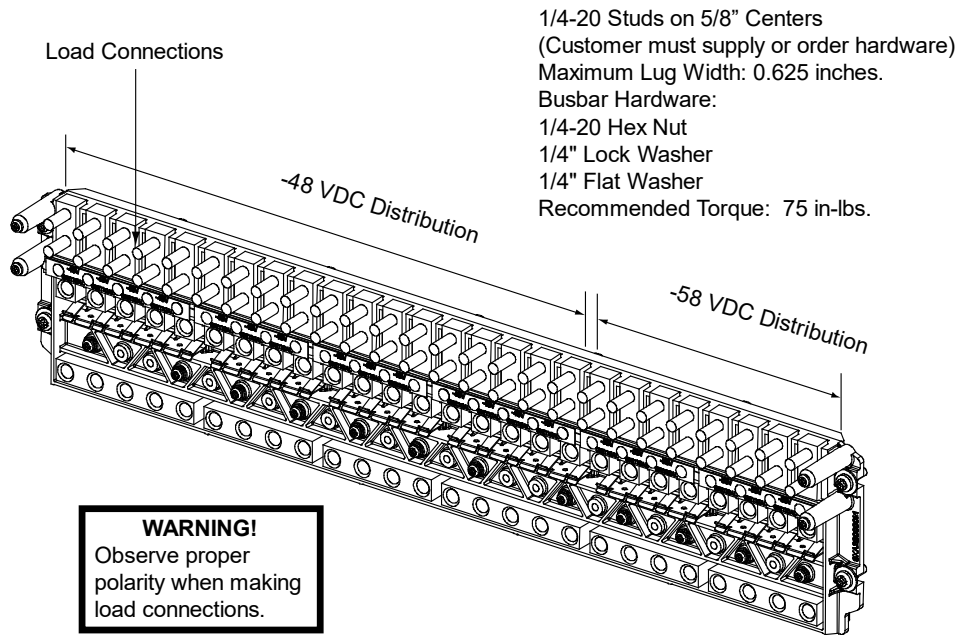
See SAG582137100 for temperature, sizing, and spacing restrictions.

**Figure 5.52 List FA Load Connections in a List 26 Distribution Cabinet**  
(22) -48 VDC Load Bullet/TPS/TLS Circuit Breaker/Fuse Positions and  
(4) -58 VDC Load Bullet/TPS/TLS Circuit Breaker/Fuse Positions



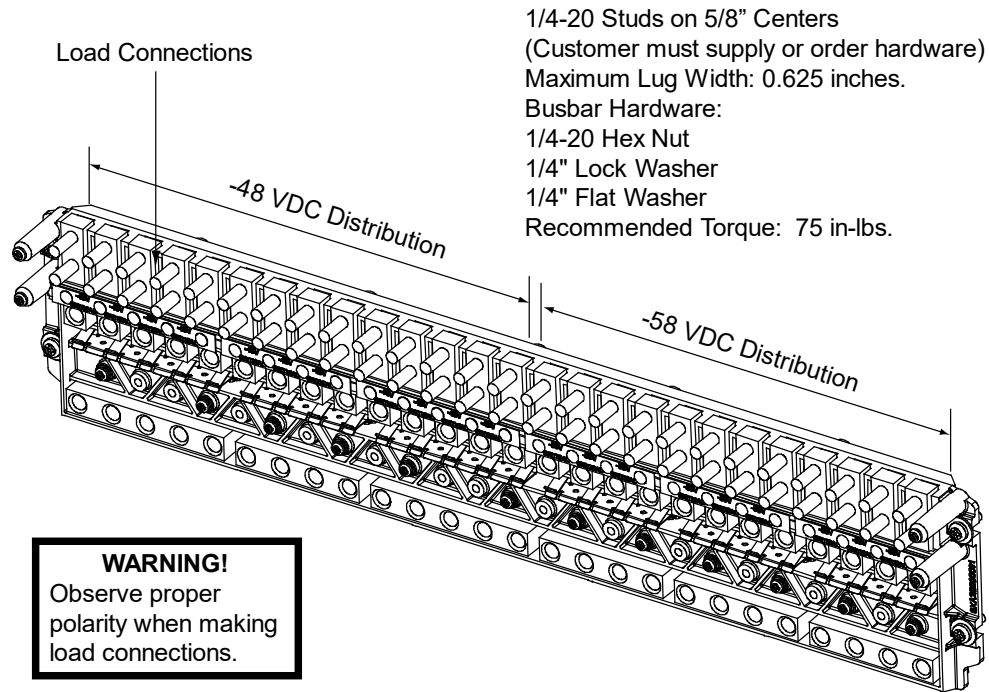
See SAG582137100 for temperature, sizing, and spacing restrictions.

**Figure 5.53 List FB Load Connections in a List 26 Distribution Cabinet**  
(18) -48 VDC Load Bullet/TPS/TLS Circuit Breaker/Fuse Positions and  
(8) -58 VDC Load Bullet/TPS/TLS Circuit Breaker/Fuse Positions



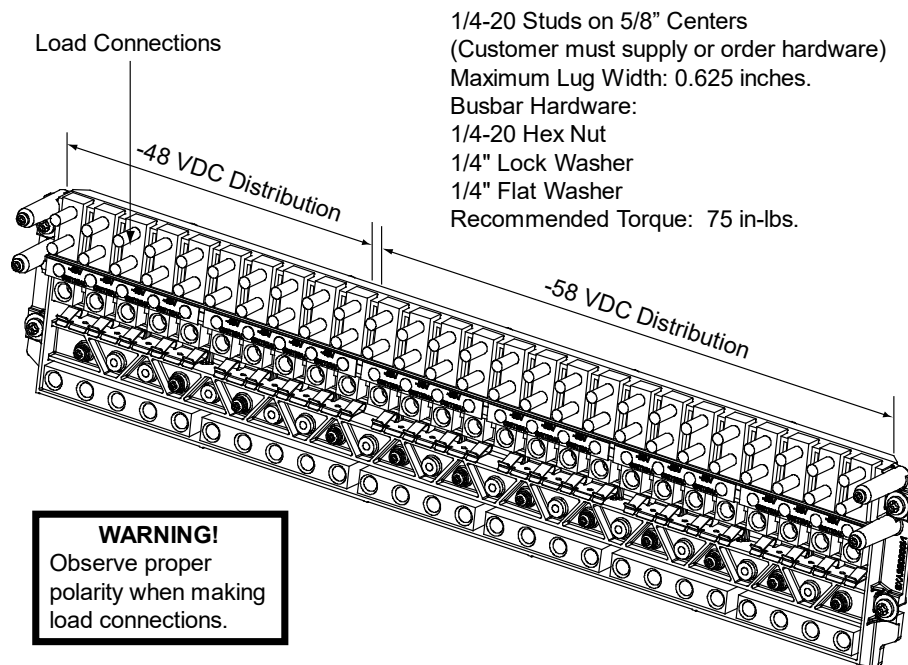
See SAG582137100 for temperature, sizing, and spacing restrictions.

**Figure 5.54** List FC Load Connections in a List 26 Distribution Cabinet  
 (14) -48 VDC Load Bullet/TPS/TLS Circuit Breaker/Fuse Positions and  
 (12) -58 VDC Load Bullet/TPS/TLS Circuit Breaker/Fuse Positions



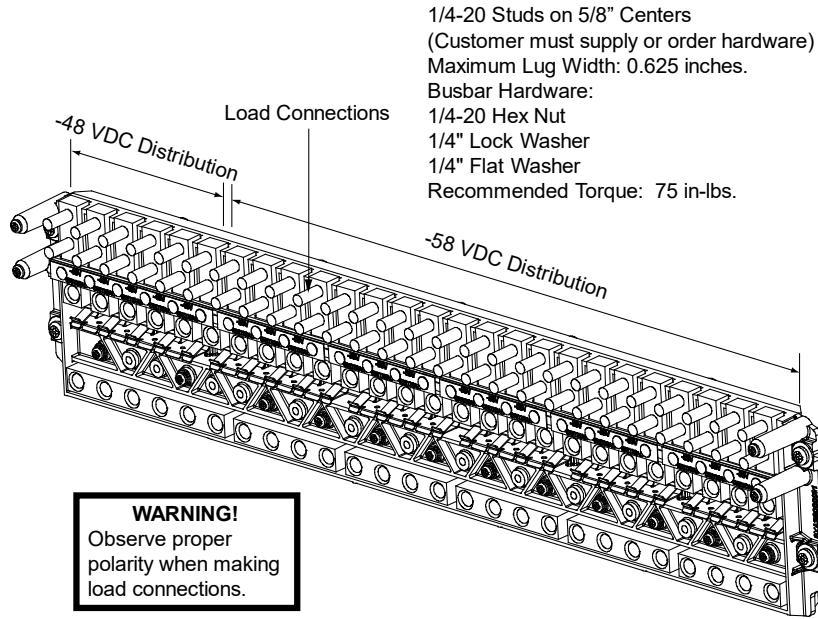
See SAG582137100 for temperature, sizing, and spacing restrictions.

**Figure 5.55** List FD Load Connections in a List 26 Distribution Cabinet  
 (10) -48 VDC Load Bullet/TPS/TLS Circuit Breaker/Fuse Positions and  
 (16) -58 VDC Load Bullet/TPS/TLS Circuit Breaker/Fuse Positions



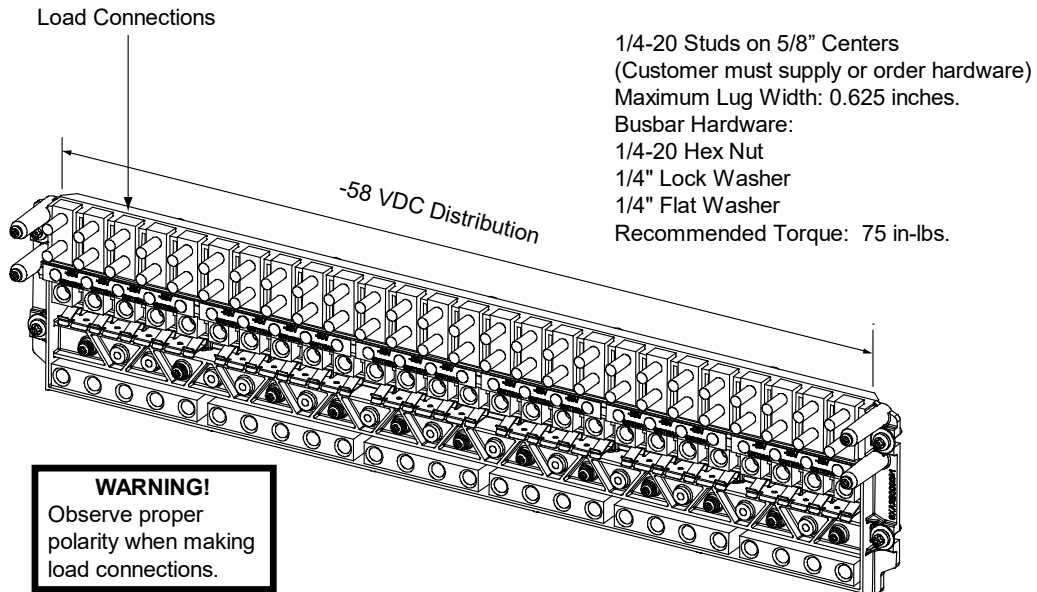
See SAG582137100 for temperature, sizing, and spacing restrictions.

**Figure 5.56** List FE Load Connections in a List 26 Distribution Cabinet  
 (6) -48 VDC Load Bullet/TPS/TLS Circuit Breaker/Fuse Positions and  
 (20) -58 VDC Load Bullet/TPS/TLS Circuit Breaker/Fuse Positions



See SAG582137100 for temperature, sizing, and spacing restrictions.

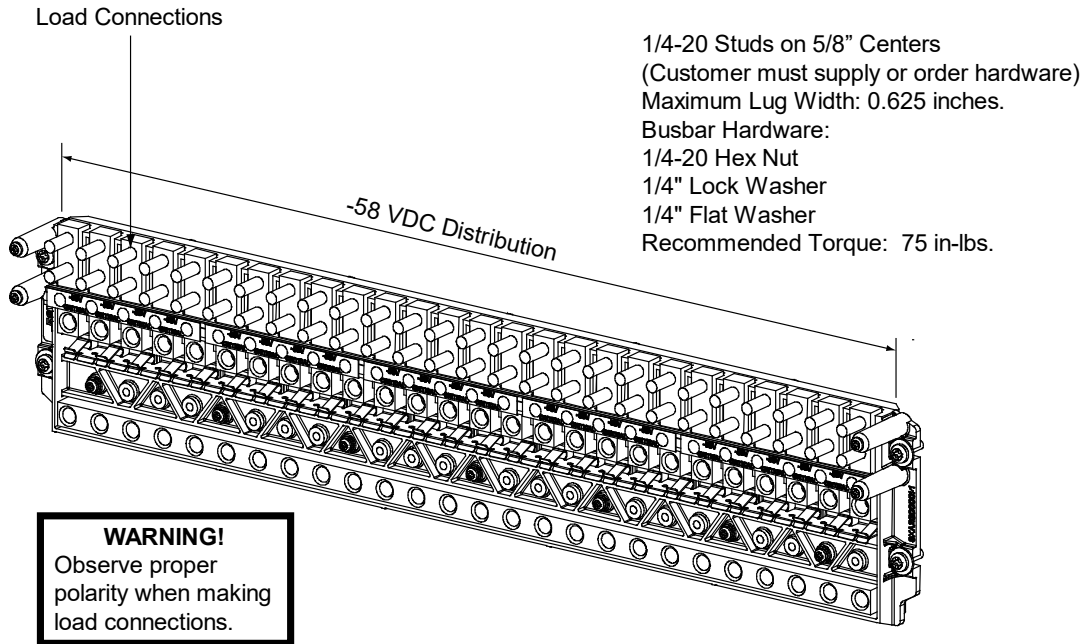
**Figure 5.57** List FF Load Connections in a List 26 Distribution Cabinet  
 (26) -58 VDC Load Bullet/TPS/TLS Circuit Breaker/Fuse Positions



See SAG582137100 for temperature, sizing, and spacing restrictions.



Figure 5.58 List GB Load Connections in a List 26 Distribution Cabinet  
(26) -58 VDC Load Bullet/TPS/TLS Circuit Breaker/Fuse Positions



See SAG582137100 for temperature, sizing, and spacing restrictions.

Note: List GB panel is installed in the bottom row of List 26.

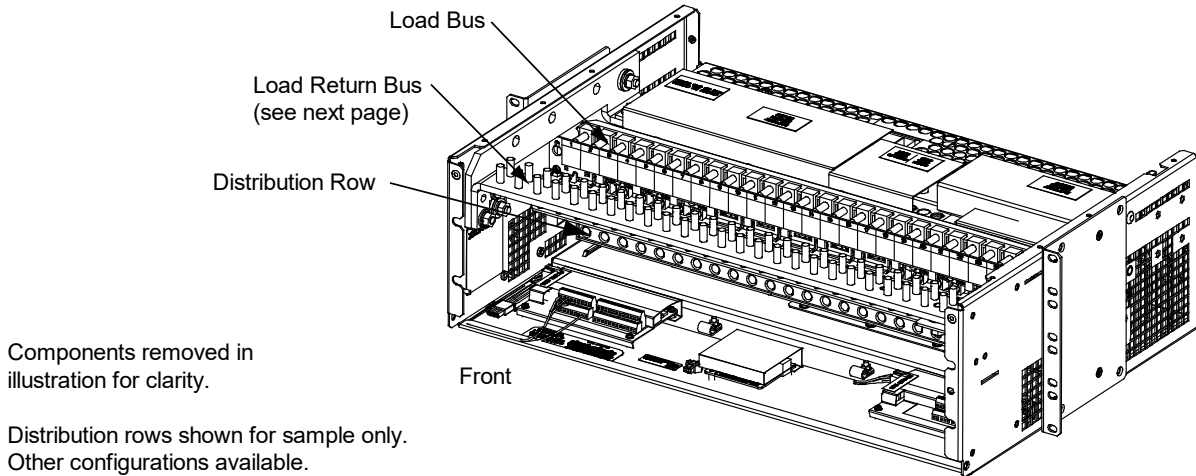
### 5.17.3 Load Connections to a List 27 Distribution Cabinet



**WARNING!** Observe proper polarity when making output connections.

Load leads are connected to the individual load busbar located on the distribution panel (refer to Figure 5.59). Load return leads are connected to separate return busbar located at the top of the distribution cabinet (refer to Figure 5.60). Refer to Figure 5.61 for an illustration of the available distribution panel. Torque connections as shown in the illustration.

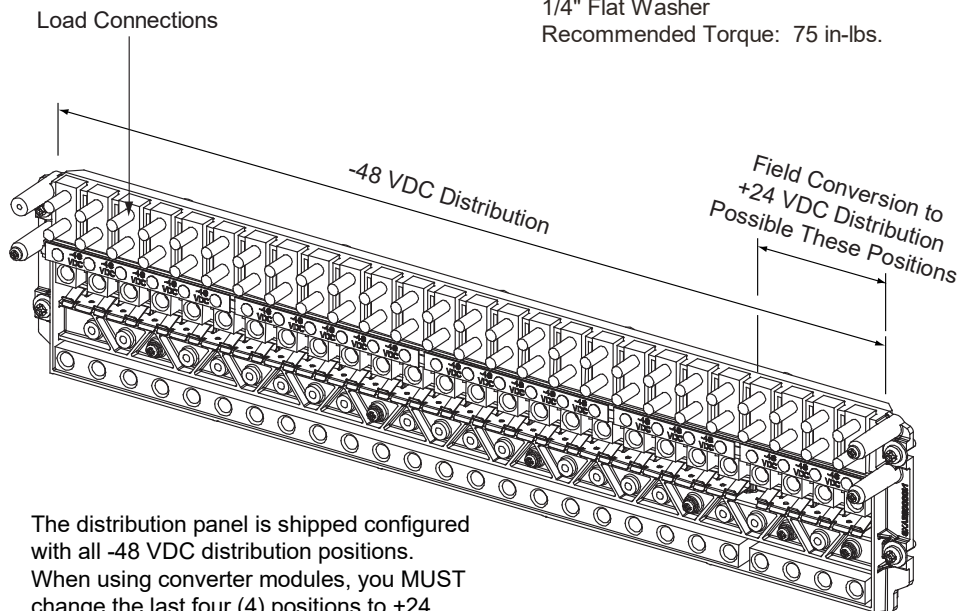
**Figure 5.59 Load Side Connections in a List 27 Distribution Cabinet**



Components removed in illustration for clarity.

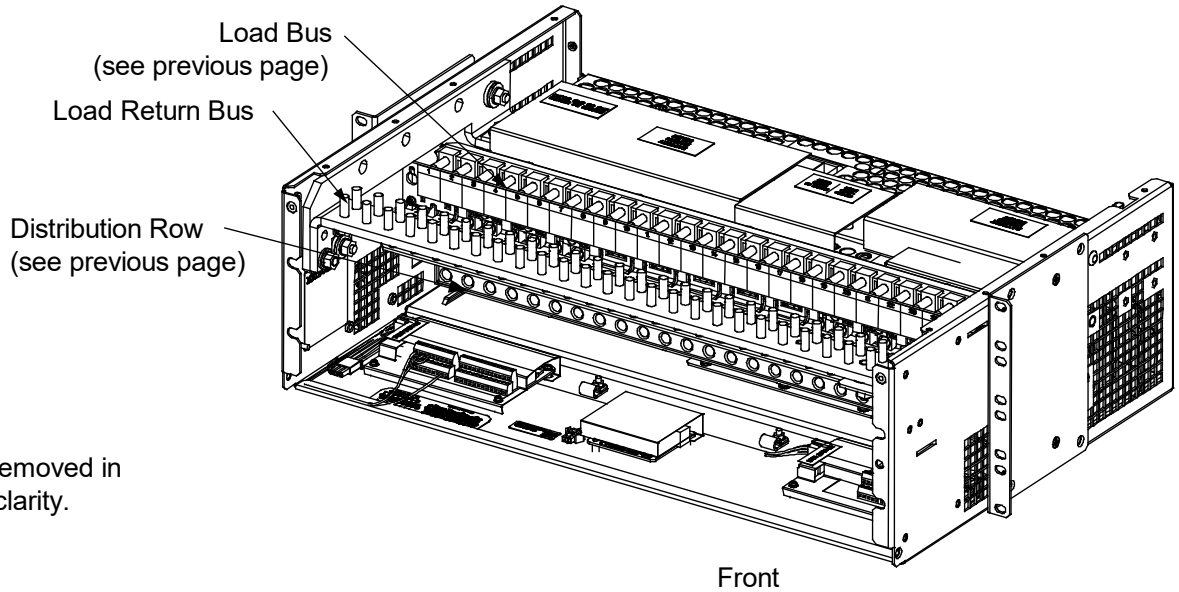
Distribution rows shown for sample only. Other configurations available.

1/4-20 Studs on 5/8" Centers  
 (Customer must supply or order hardware)  
 Maximum Lug Width: 0.625 inches.  
 Busbar Hardware:  
 1/4-20 Hex Nut  
 1/4" Lock Washer  
 1/4" Flat Washer  
 Recommended Torque: 75 in-lbs.

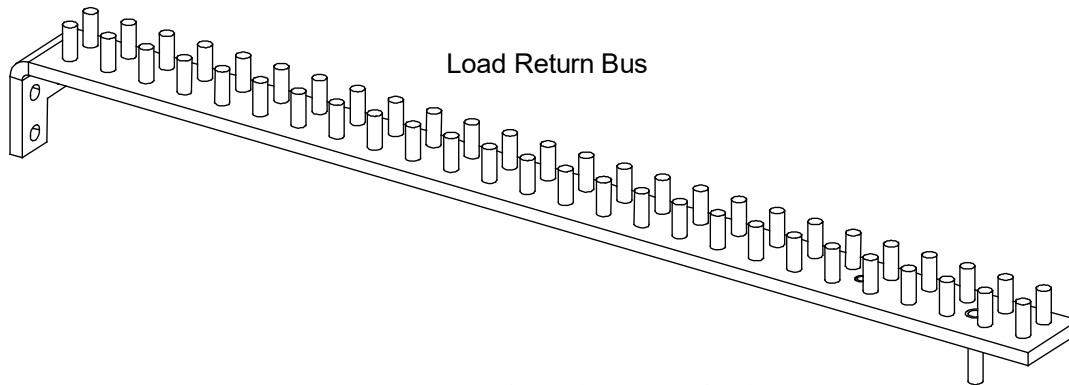


The distribution panel is shipped configured with all -48 VDC distribution positions. When using converter modules, you **MUST** change the last four (4) positions to +24 VDC distribution positions in the field. Refer to UM582137100 for a procedure.

**Figure 5.60** Load Return Side Connections in a List 27 Distribution Cabinet



Components removed in illustration for clarity.

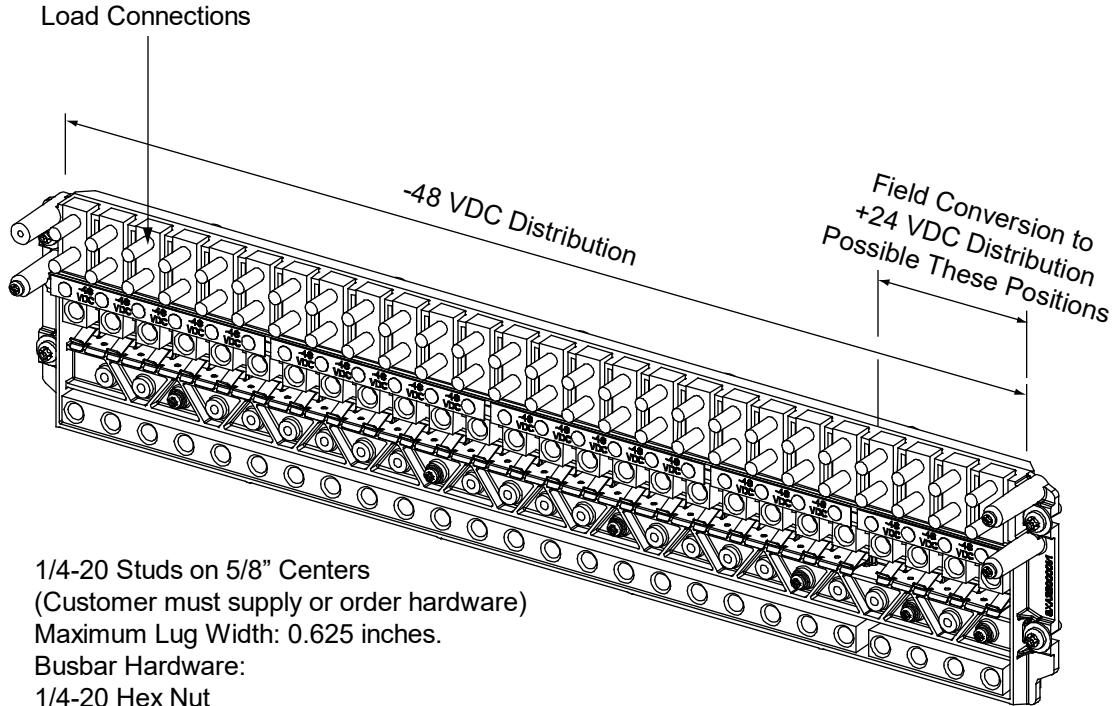


1/4-20 Studs on 5/8" Centers  
 (Customer must supply or order hardware)  
 Maximum Lug Width: 0.625 inches.  
 Busbar Hardware:  
 1/4-20 Hex Nut  
 1/4" Lock Washer  
 1/4" Flat Washer  
 Recommended Torque: 75 in-lbs.

## Load Connections to Dual Voltage Distribution Panel in a List 27 Distribution Cabinet

**Figure 5.61** List DF Load Connections in a List 27 Distribution Cabinet

(26) -48 VDC Load Bullet/TPS/TLS Circuit Breaker/Fuse Positions and  
(4) Positions Can Be Converted from -48 VDC to +24 VDC Positions in the Field



1/4-20 Studs on 5/8" Centers  
(Customer must supply or order hardware)  
Maximum Lug Width: 0.625 inches.  
Busbar Hardware:  
1/4-20 Hex Nut  
1/4" Lock Washer  
1/4" Flat Washer  
Recommended Torque: 75 in-lbs.

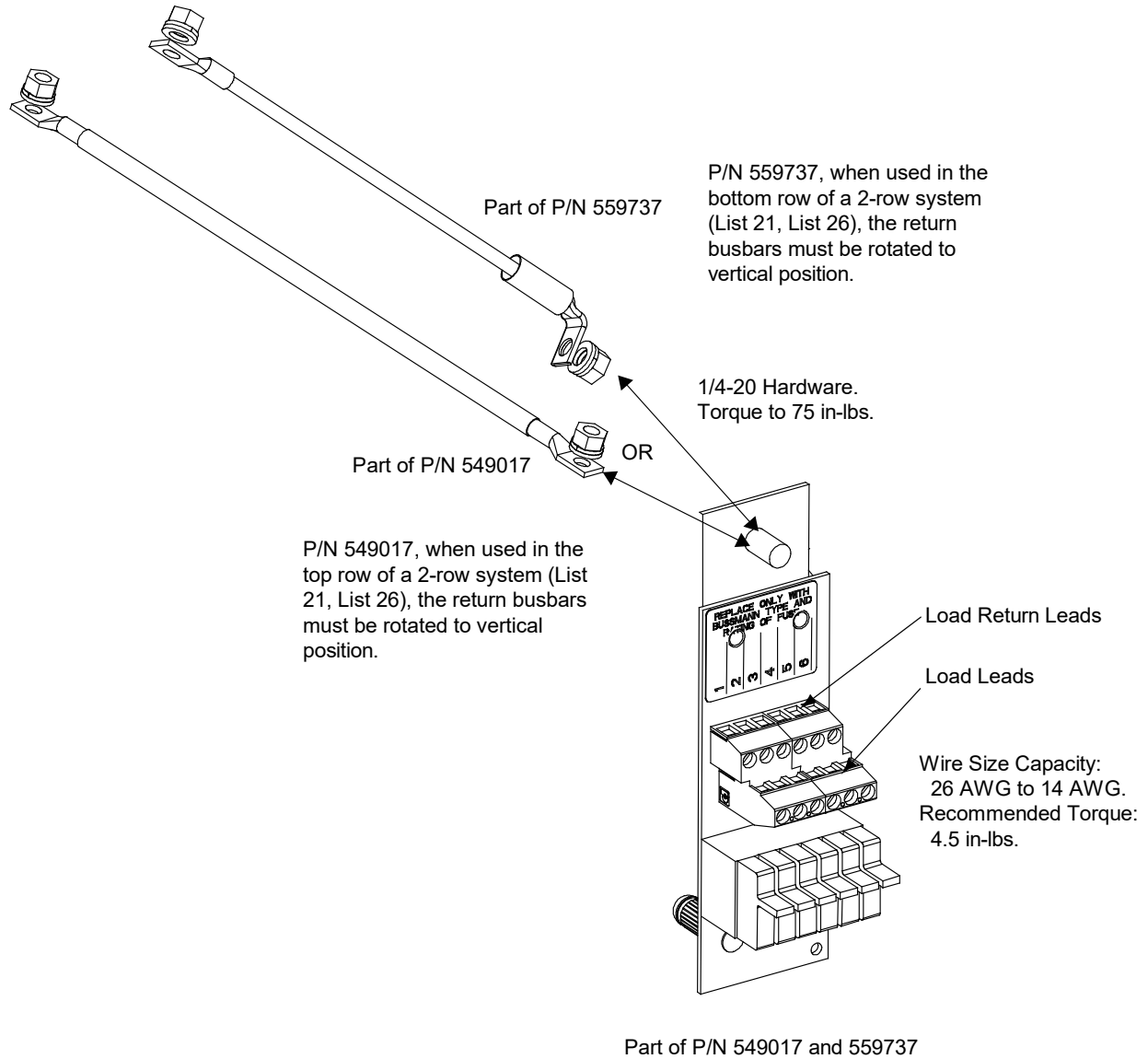
The distribution panel is shipped configured with all -48 VDC distribution positions. When using converter modules, you **MUST** change the last four (4) positions to +24 VDC distribution positions in the field. Refer to UM582137100 for a procedure.

### 5.17.4 Load Connections to an Optional GMT Fuse Block

**WARNING!** Observe proper polarity when making output connections.

Refer to Figure 5.62 if an optional “Bullet Nose Type 6-Position GMT Distribution Fuse Block” is furnished. Torque connections as shown in the illustration.

**Figure 5.62** Load Connections to an Optional GMT Fuse Block



### 5.17.5 Load Connections to a List KG Distribution Panel

Refer to Figure 5.63.

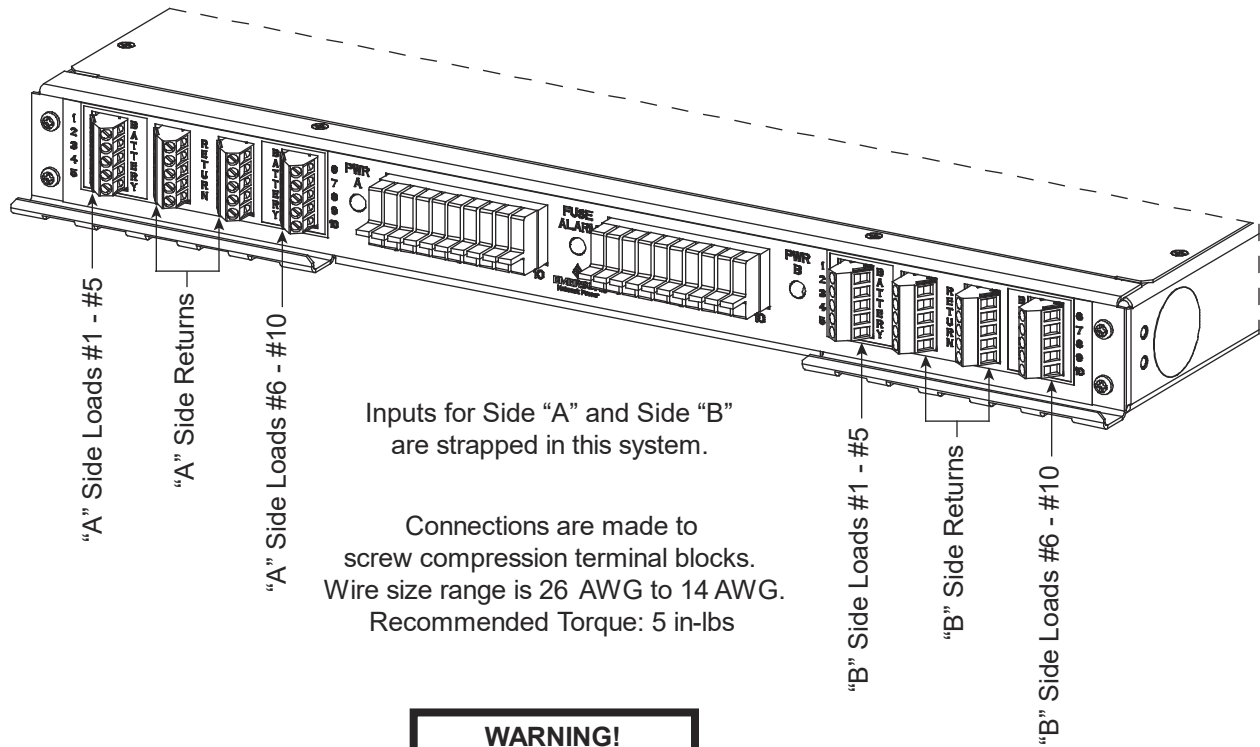


**NOTE!** "A" Side and "B" Side inputs are strapped in this power system.

#### GMT Fuse Blocks

Load and load return leads are connected to screw-type terminal blocks located on the front of the distribution panel. Refer to Figure 5.63 for terminal block wire size capacity and recommended torque.

**Figure 5.63** Load Connections to a List KG Distribution Panel



**WARNING!**  
Observe proper polarity when making load connections.

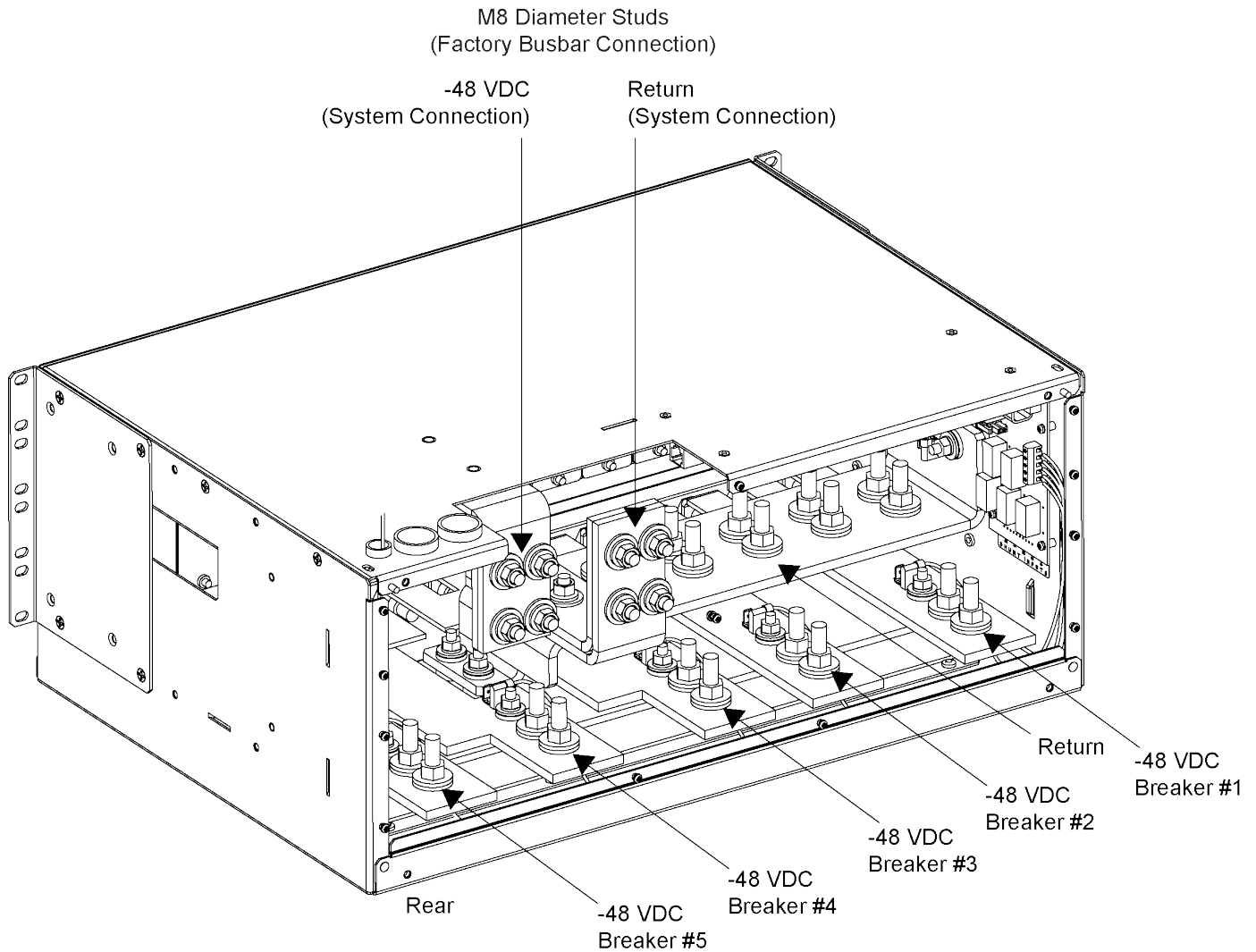
## 5.18 Connections to an Optional List 60 Hybrid Connection Cabinet



**WARNING!** Observe proper polarity when making output connections.

Refer to Figure 5.64 for terminal location and torque information.

**Figure 5.64** Connections to an Optional List 60 Hybrid Connection Cabinet



3/8" Studs on 1" Centers  
Maximum Lug Width: 2 inches.  
Hardware:  
3/8" Hex Nut  
3/8" Lock Washer  
3/8" Flat Washer  
Torque to 300 in-lbs.

## 5.19 Input Battery Connections

### 5.19.1 Input Battery Connections to List 20, 25 Distribution Cabinet

Refer to the following.

#### Important Safety Instructions



**DANGER!** Adhere to the “Important Safety Instructions” starting on page vii.



**WARNING!** Observe proper polarity when making output connections.

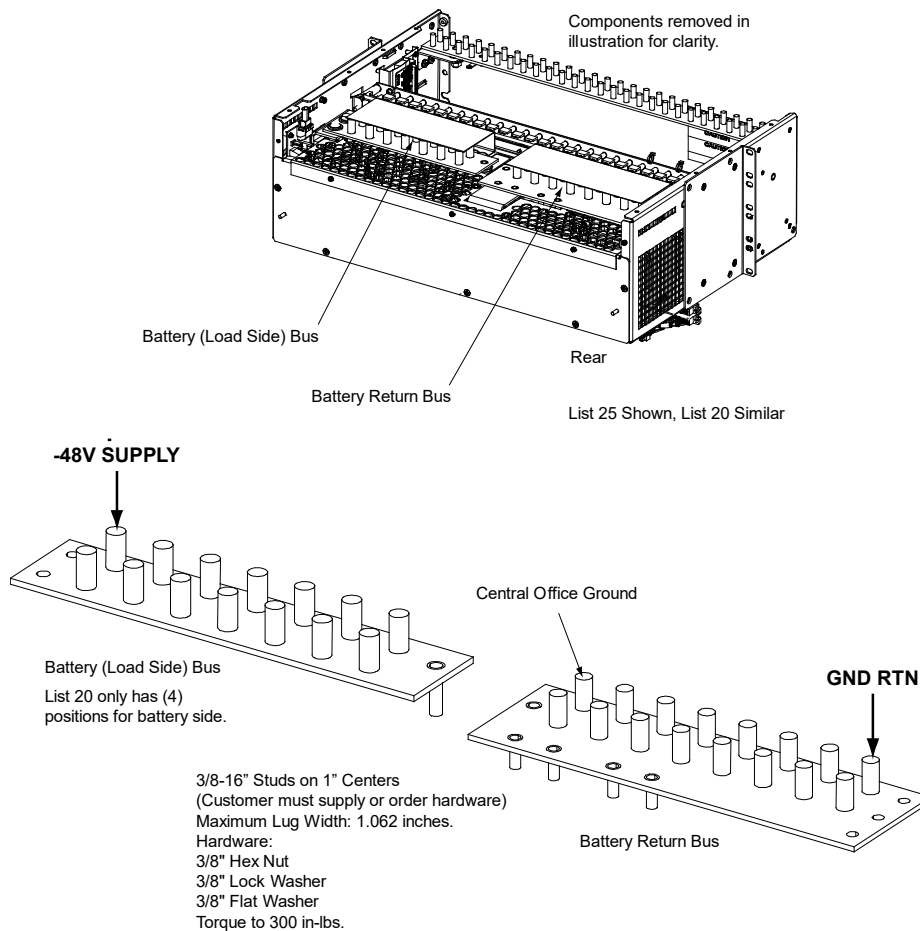
#### To Battery and Battery Return Busbars

Input battery leads are connected to the battery (load side) busbar and battery return busbar. Refer to Figure 5.65 for connection details and recommended torque.

#### To Battery Disconnect Circuit Breakers and Battery Return Busbar (if furnished)

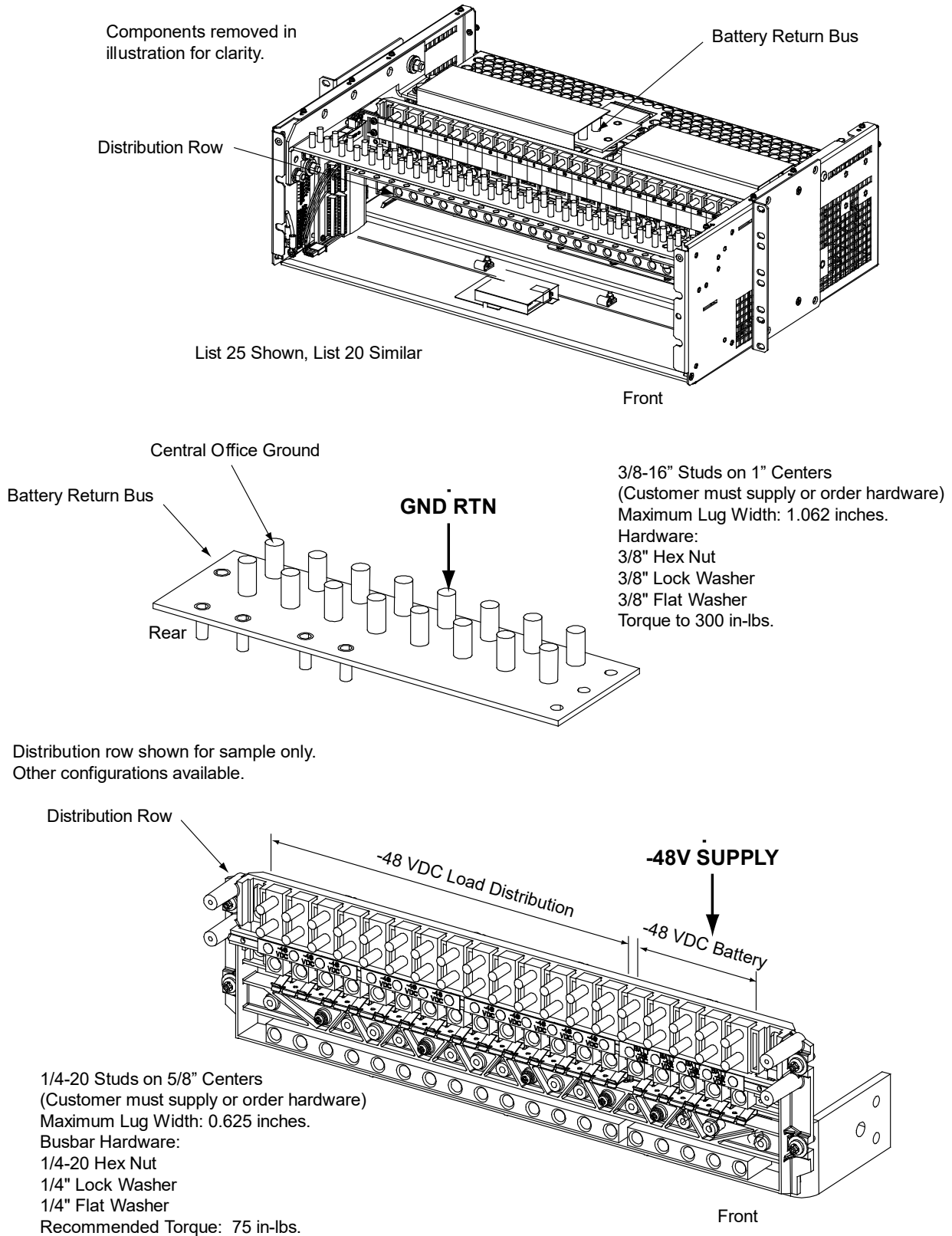
Input battery leads are connected to the battery disconnect device battery busbars located on the distribution panel. Battery return leads are connected to the battery return busbar located at the top of the distribution cabinet. Refer to Figure 5.66 for connection details. Refer to Figure 5.67 through Figure 5.69 for illustrations of the available distribution panels. Torque connections as shown in the illustrations.

**Figure 5.65 Battery and Central Office Ground Connections to List 20, 25 Distribution Cabinet Battery Busbars**





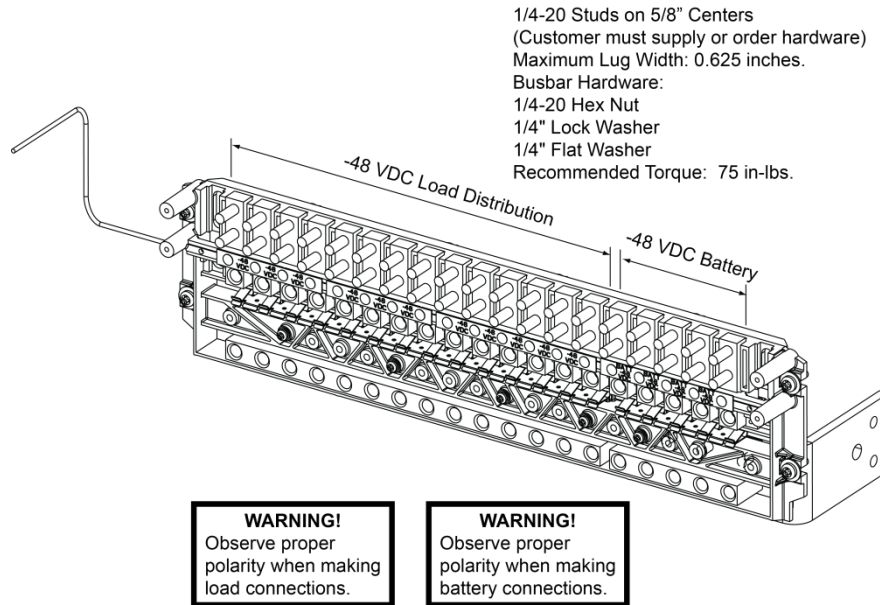
**Figure 5.66 Battery and Central Office Ground Connections to List 20, 25 Battery Disconnect Distribution Positions**



**Battery Connections to Single Voltage Plus Battery Disconnect Distribution Panels in a List 20, 25 Distribution Cabinet**

**Figure 5.67** List BN Battery Connections in a List 20 Distribution Cabinet

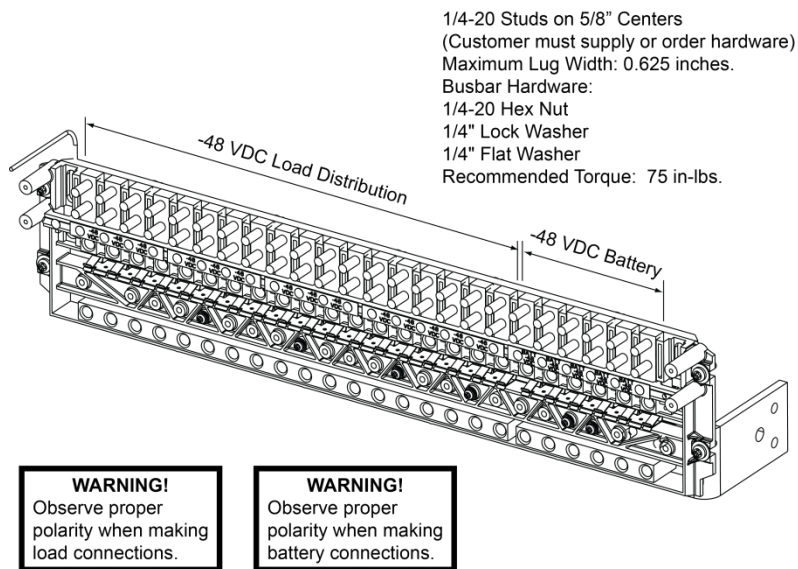
- (14) -48 VDC Load Bullet/TPS/TLS Circuit Breaker/Fuse Positions and
- (5) -48 VDC Battery Disconnect Bullet/TPS/TLS Circuit Breaker/Fuse Positions



See SAG582137100 for temperature, sizing, and spacing restrictions.

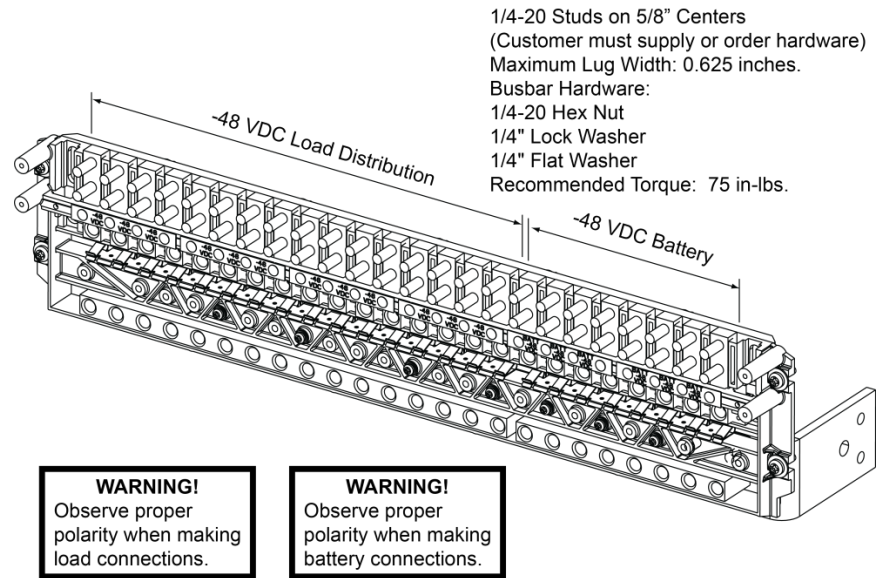
**Figure 5.68** List BA Battery Connections in a List 25 Distribution Cabinet

- (18) -48 VDC Load Bullet/TPS/TLS Circuit Breaker/Fuse Positions and
- (6) -48 VDC Battery Disconnect Bullet/TPS/TLS Circuit Breaker/Fuse Positions



See SAG582137100 for temperature, sizing, and spacing restrictions.

**Figure 5.69 List BC Battery Connections in a List 25 Distribution Cabinet**  
 (16) -48 VDC Load Bullet/TPS/TLS Circuit Breaker/Fuse Positions and  
 (8) -48 VDC Battery Disconnect Bullet/TPS/TLS Circuit Breaker/Fuse Positions



See SAG582137100 for temperature, sizing, and spacing restrictions.

## 5.19.2 Input Battery Connections to List 21, 26 Distribution Cabinet

Refer to the following.

### **Important Safety Instructions**



**DANGER!** Adhere to the "Important Safety Instructions" starting on page vii.



**WARNING!** Observe proper polarity when making output connections.

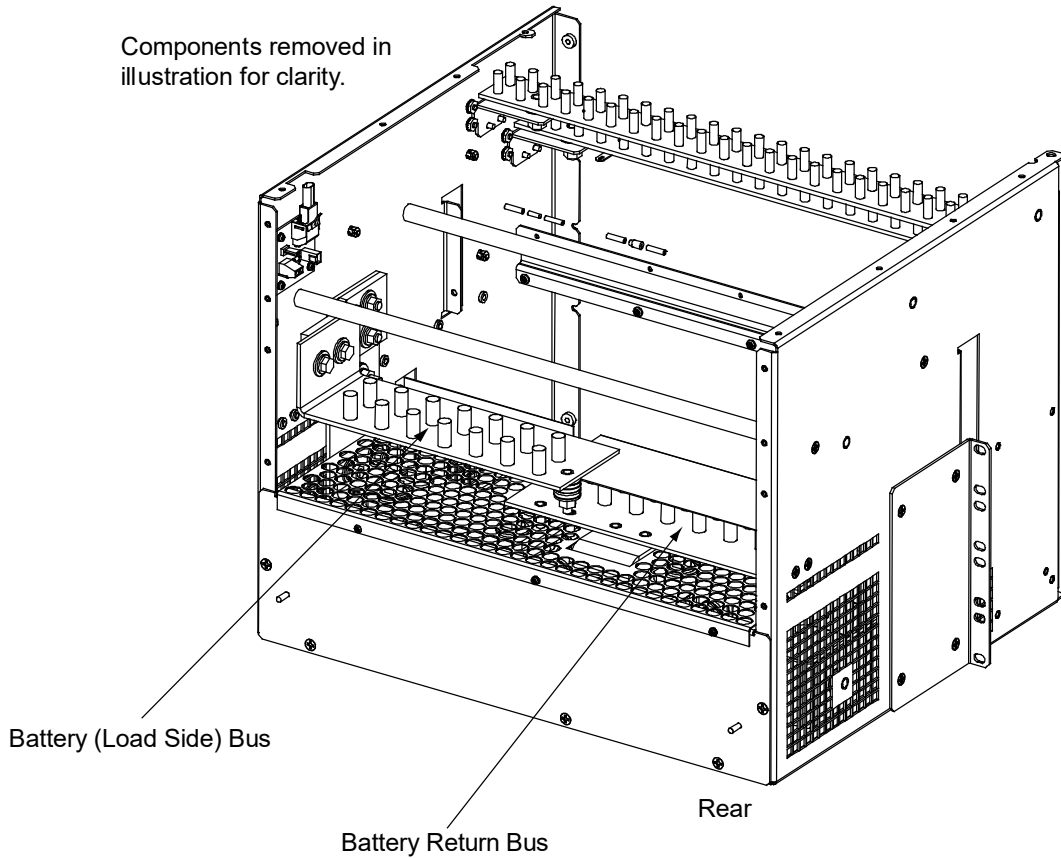
### **To Battery and Battery Return Busbars**

Input battery leads are connected to the battery (load side) busbar and battery return busbar. Refer to Figure 5.70 for connection details and recommended torque.

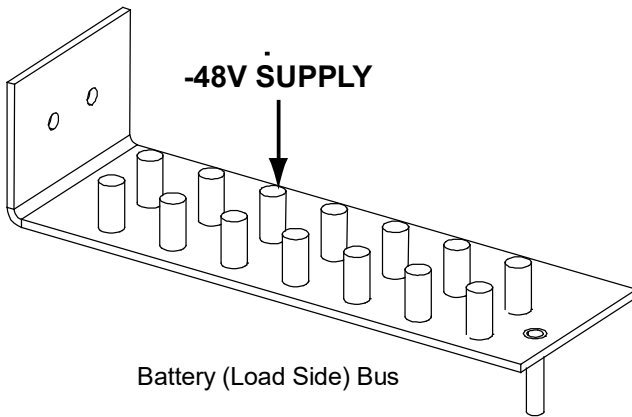
### **To Battery Disconnect Circuit Breakers and Battery Return Busbar (if furnished)**

Input battery leads are connected to the battery disconnect device battery busbars located on the distribution panel. Battery return leads are connected to the battery return busbar located at the top of the distribution cabinet. Refer to Figure 5.71 for connection details. Refer to Figure 5.72 through Figure 5.74 for illustrations of the available distribution panels. Torque connections as shown in the illustrations.

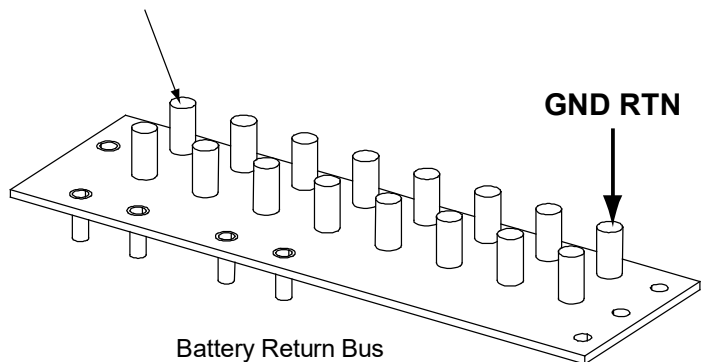
**Figure 5.70** Battery and Central Office Ground Connections to List 21, 26 Distribution Cabinet Battery Busbars



List 21 Shown, List 26 Similar

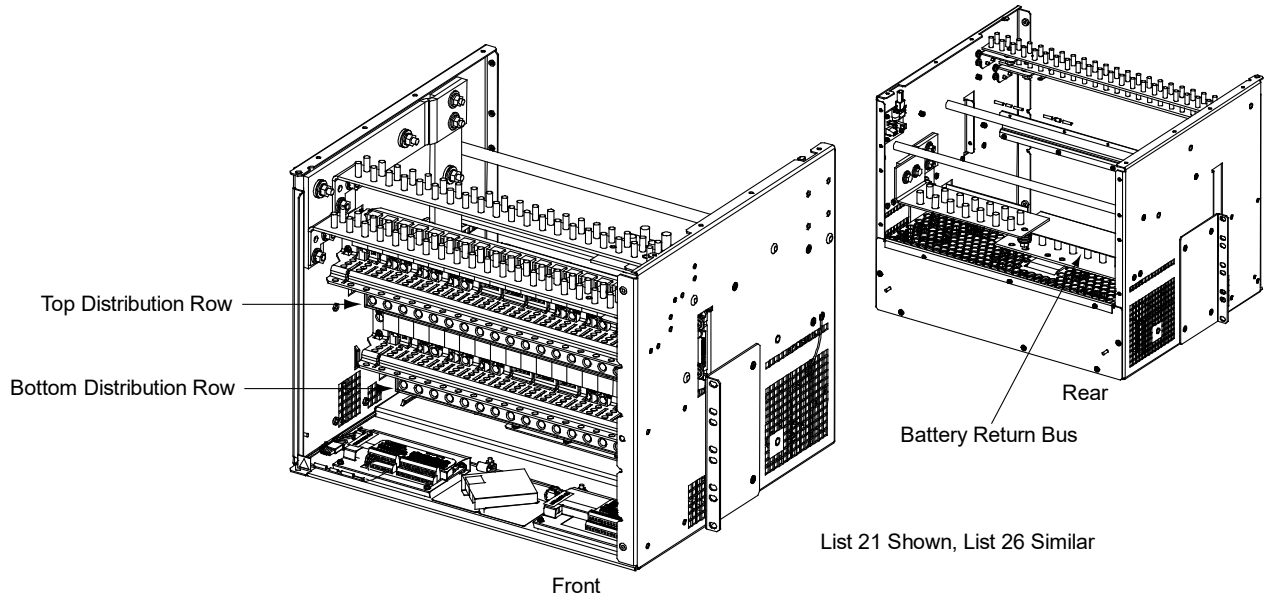


Central Office Ground

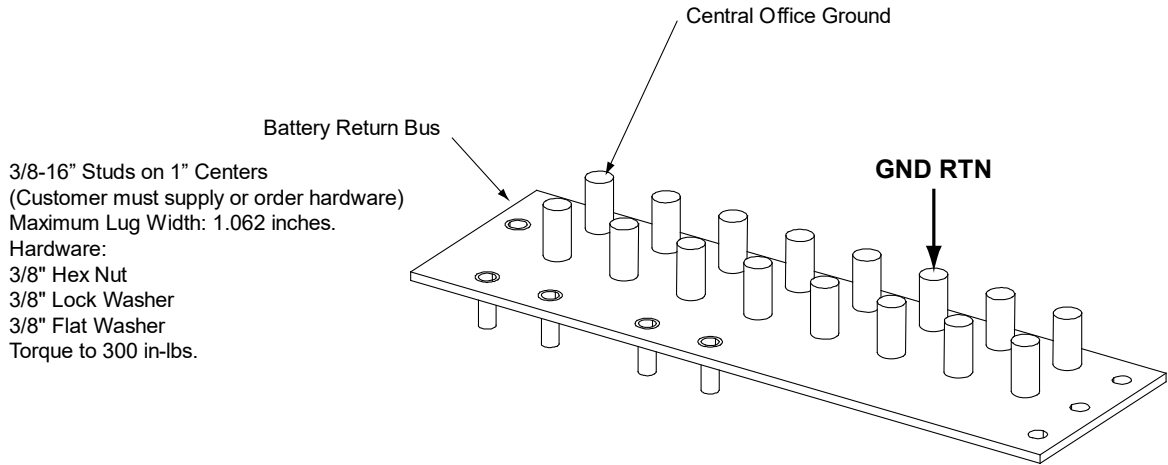


3/8-16" Studs on 1" Centers  
 (Customer must supply or order hardware)  
 Maximum Lug Width: 1.062 inches.  
 Hardware:  
 3/8" Hex Nut  
 3/8" Lock Washer  
 3/8" Flat Washer  
 Torque to 300 in-lbs.

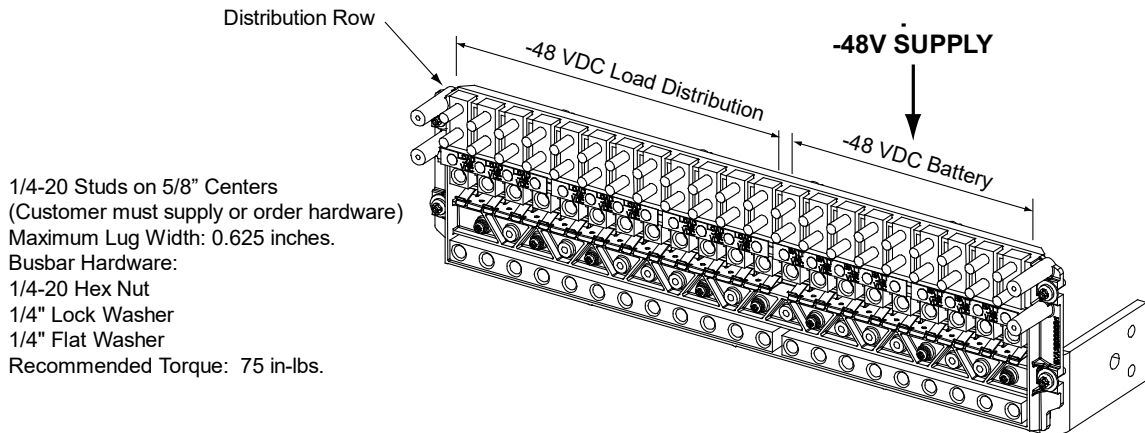
**Figure 5.71 Battery and Central Office Ground Connections to List 21, 26 Battery Disconnect Distribution Positions**



Components removed in illustration for clarity.

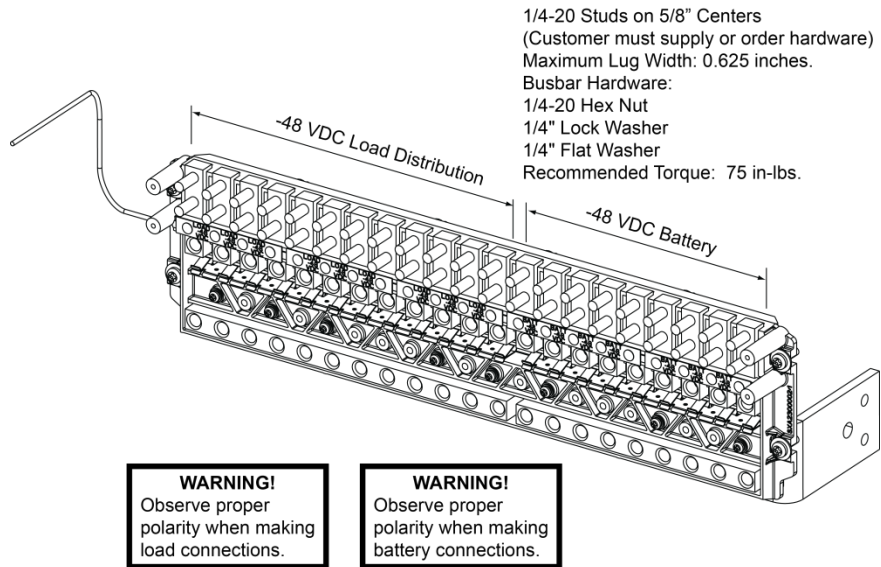


Distribution row shown for sample only.  
Other configurations available.



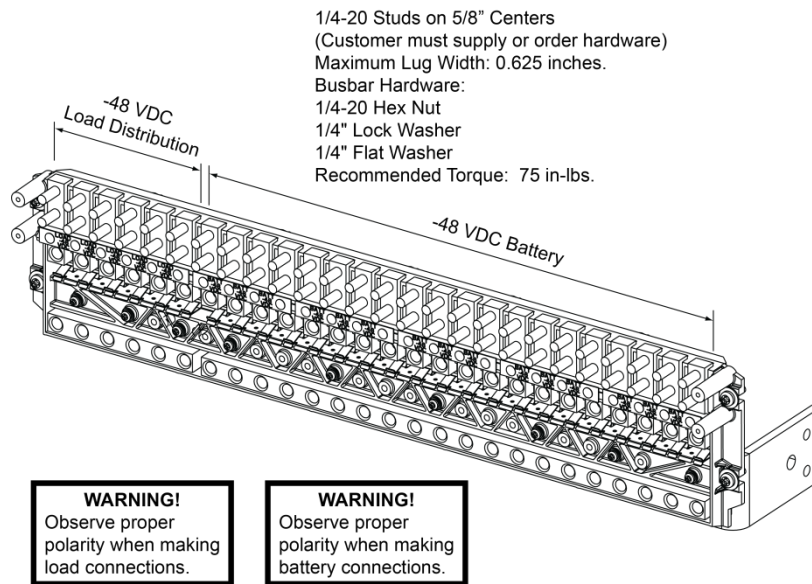
**Battery Connections to Single Voltage Plus Battery Disconnect Distribution Panels in a List 21, 26 Distribution Cabinet**

**Figure 5.72 List BO Battery Connections in a List 21 Distribution Cabinet**  
 (12) -48 VDC Load Bullet/TPS/TLS Circuit Breaker/Fuse Positions and  
 (9) -48 VDC Battery Disconnect Bullet/TPS/TLS Circuit Breaker/Fuse Positions



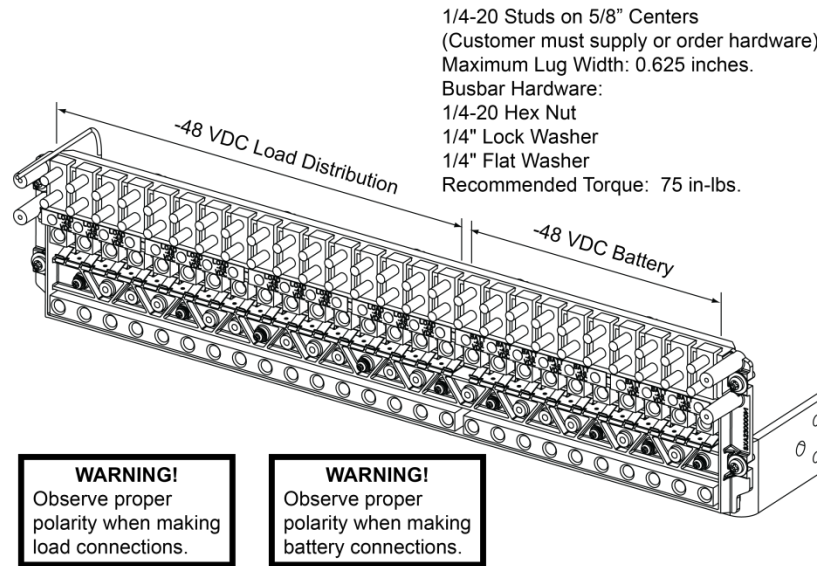
See SAG582137100 for temperature, sizing, and spacing restrictions.

**Figure 5.73 List BB Battery Connections in a List 26 Distribution Cabinet**  
 (6) -48 VDC Load Bullet/TPS/TLS Circuit Breaker/Fuse Positions and  
 (20) -48 VDC Battery Disconnect Bullet/TPS/TLS Circuit Breaker/Fuse Positions



See SAG582137100 for temperature, sizing, and spacing restrictions.

**Figure 5.74 List BD Battery Connections in a List 26 Distribution Cabinet**  
 (16) -48 VDC Load Bullet/TPS/TLS Circuit Breaker/Fuse Positions and  
 (10) -48 VDC Battery Disconnect Bullet/TPS/TLS Circuit Breaker/Fuse Positions



See SAG582137100 for temperature, sizing, and spacing restrictions.

### 5.19.3 Input Battery Connections to List 27 Distribution Cabinet

Refer to the following.

#### **Important Safety Instructions**



**DANGER!** Adhere to the "Important Safety Instructions" starting on page vii.



**WARNING!** Observe proper polarity when making output connections.

#### **To Battery and Battery Return Busbars**

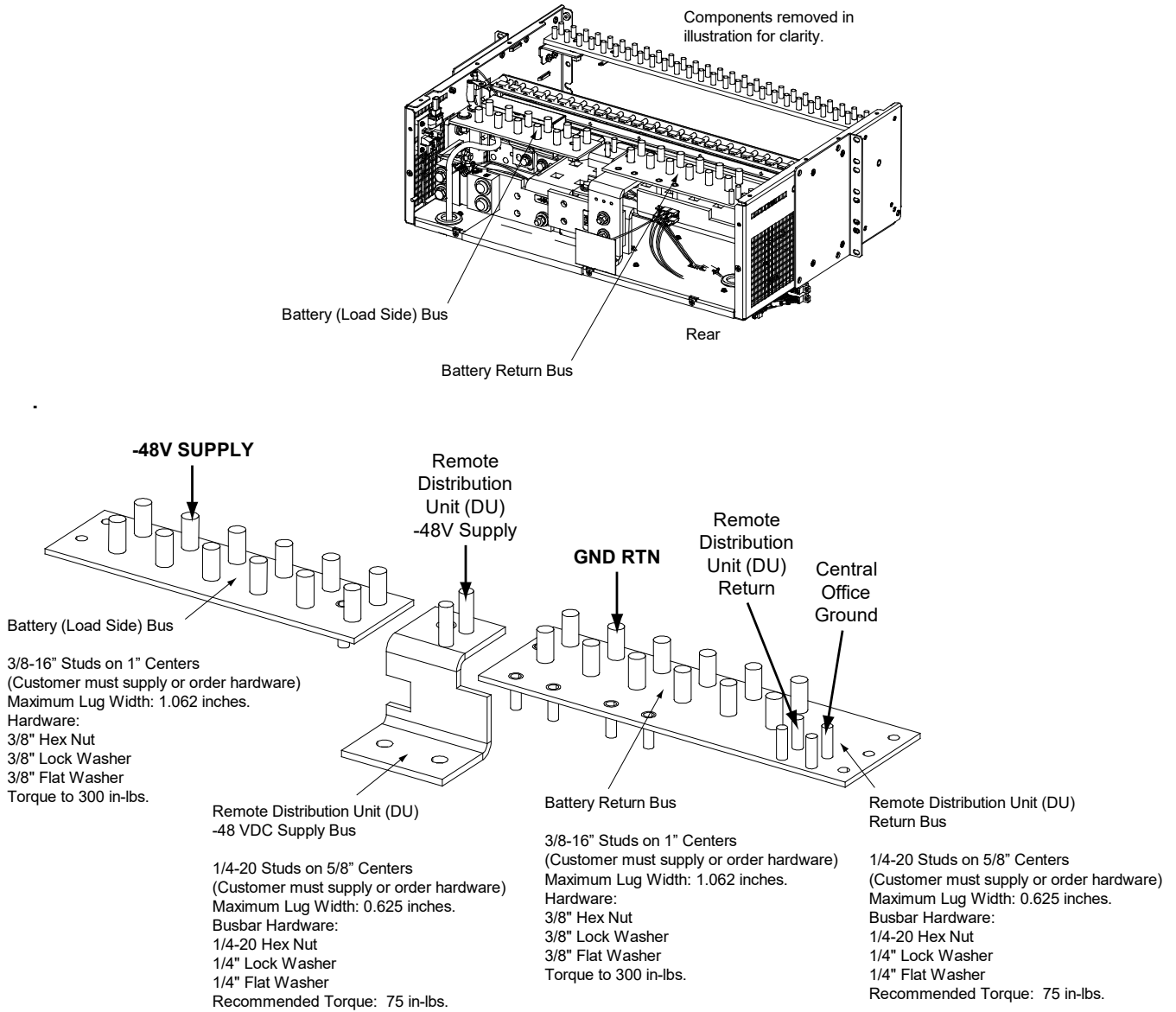
Input battery leads are connected to the battery (load side) busbar and battery return busbar. Refer to Figure 5.75 for connection details and recommended torque.

## 5.20 Remote Distribution Unit (DU) Connections

### 5.20.1 List 27 Distribution Cabinet

Remote Distribution Unit (DU) input leads are connected to the remote DU input busbar and battery return busbar. Refer to Figure 5.75 for connection details and recommended torque.

**Figure 5.75 Battery, Remote DU, and Central Office Ground Connections to List 27 Distribution Cabinet Battery Busbars**





## 5.21 Installing and Connecting Batteries in an Optional List 93 or 94 Battery Tray (if furnished)

### 5.22 Important Safety Instructions



**DANGER!** Adhere to the “Important Safety Instructions” starting on page vii.

#### **Battery Manufacturer Information**

Refer to System Application Guide SAG582137100 for specifications and manufacturers of the batteries to be installed in this power system.

#### **Installing and Connecting Batteries**



**DANGER!** Adhere to the “Important Safety Instructions” starting on page vii.

#### **Procedure**

Tray P/N 559806 is used in the following procedure. The procedure for all other available trays is similar.



**NOTE!** Refer to Figure 5.76 as this procedure is performed.

1. **If Battery Trays are Equipped With a Circuit Breaker:** Turn OFF the battery Disconnect circuit breaker located on all battery trays. Refer to Figure 5.76 for locations. Follow local lockout/tagout procedures to ensure circuit breakers remain in the off position during installation.
2. Remove the battery retention bracket as shown in Figure 5.76. To do so, remove the four 1/4-20 x 5/8” bolts and associated washers.
3. Slide batteries into the tray, with the battery terminals toward the front as shown in Figure 5.76. Slide batteries into the tray as far as they will go.



**NOTE!** The battery retention bracket can be oriented two ways to accommodate batteries of different lengths. A correctly oriented bracket will fit snugly against the batteries. If your batteries require the alternate bracket orientation shown in Detail A of Figure 5.76, remove and reinstall the bullet-shaped spacers (trays P/N 559806 and 559807 only) as shown in Detail A before performing the next step.

4. Reinstall the battery retention bracket. The spacers on the bracket should separate the batteries from each other. Secure with the hardware removed in a previous step. Refer to Figure 5.76 for washer location.



**NOTE!** The spacers on the bracket are used to accommodate the various sizes of batteries available. Install or remove the spacers as required so that the batteries are tight in the battery tray.

5. Connect three links supplied by the battery manufacturer between pairs of battery terminals as shown in Figure 5.76. Use hardware furnished by the battery manufacturer. Torque hardware to battery manufacturer’s recommendations.
6. Ensure the battery cable ends in all trays are insulated with sleeving before performing the next step.



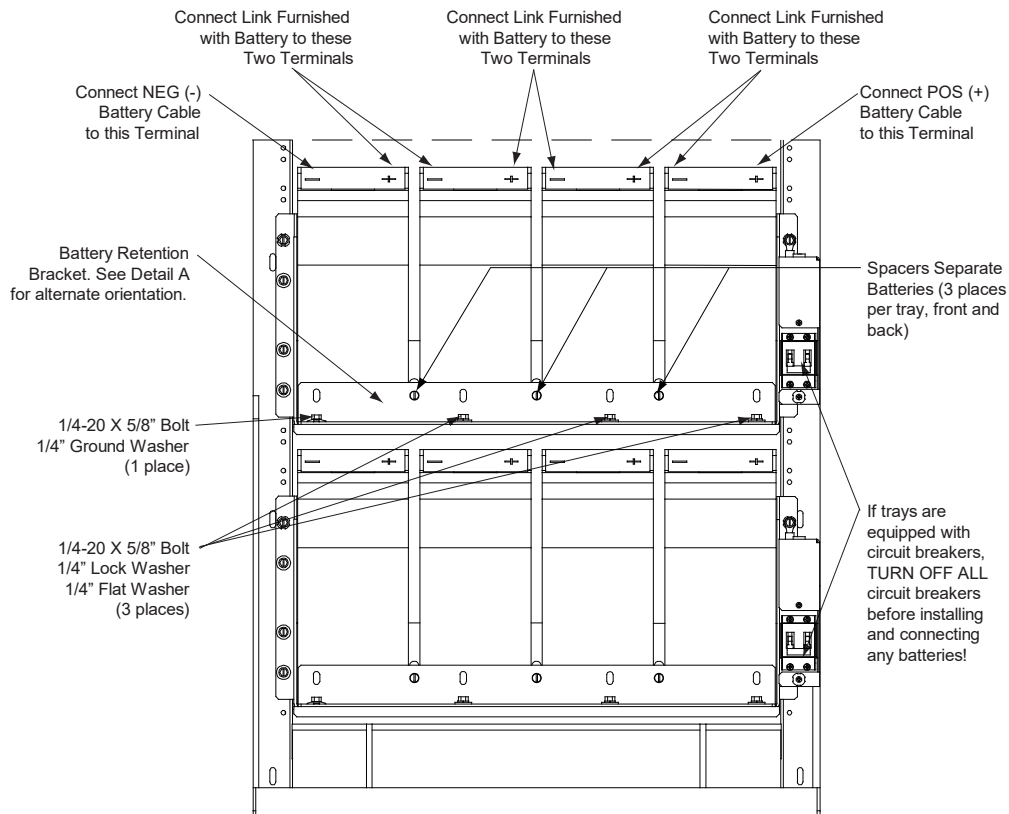
**DANGER!** In multiple-tray installations, when batteries in one tray are connected, the battery cables in all trays will be energized. Remove sleeving from and connect one cable at a time. Do not allow a cable end to contact the battery tray or equipment rack.



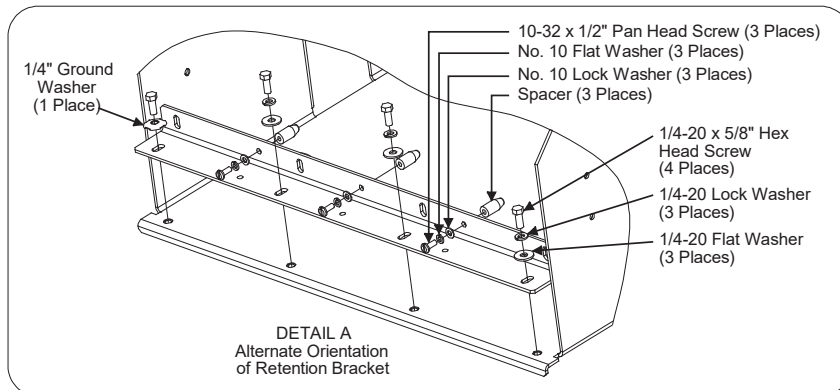
**WARNING!** In the next step, observe correct polarity. Connect only cables labeled “+” to battery terminals labeled “+”. Likewise, connect only cables labeled “-” to battery terminals labeled “-”.

7. Connect the cables found in the battery tray to the battery terminals, “+” to “+” and “-” to “-”. Observe correct polarity. Refer to Figure 5.76. Secure with hardware furnished with the battery. Torque hardware to battery manufacturer’s recommendations.
8. Repeat steps 1 through 7 for any remaining battery trays.
9. **If Battery Trays Are Equipped With a Circuit Breaker:** To connect the batteries to the power system, turn ON the battery disconnect circuit breaker located on all battery trays.

**Figure 5.76 List 93 and 94 Battery Tray Battery Installation Details**



Note:  
 1. Two trays shown as example.  
 2. Cabling detail omitted.



## 6 Installing the Modules

### 6.1 Installing Rectifier, Solar Converter, and Converter Modules

Rectifier, solar converter, optional -48 VDC to +24 VDC converter modules, and optional -48 VDC to -58 VDC converter modules can be inserted or removed with power applied (hot swappable).

#### Procedure



**NOTE!** Each module locks into the module mounting assembly by means of a latch located on the bottom of the module. The latch and module handle are interactive. Pushing the handle up into the module's front panel causes the latch to extend to the locking position; pulling the handle down out from the module's front panel causes the latch to retract. See Figure 6.3, Figure 6.4, or Figure 6.5.



**NOTE!** For systems using an AC feed option where each feed connects to two (2) slots in the shelf (List 46 or Molex connected cords) and -48 VDC to +24 VDC converters or -48 VDC to -58 VDC converters are being used (List 26 two row distribution panel or List 27 single row distribution panel) in the plant, the following module restrictions apply for factory installed shelves 2 through 5:

- Rectifiers can be in any or all six (6) positions if three (3) AC inputs provided.
- +24V or -58V converters can be in the right three (3) positions (positions 4, 5 and 6).
- Rectifiers can be in any position which has AC power that is not taken up with a converter.
- One (1) Solar converter can be installed in the shelf, position 1 or 2.
- Three (3) solar converters can be installed in the shelf, positions 1 or 2, positions 3 or 4 and positions 5 or 6 if the -48V to +24V or -48V to -58V bus bar is not installed to the shelf above.



**WARNING!** To prevent damage to the latching mechanism, ensure the handle is in the open position when installing or removing a module. NEVER hold the handle in the closed position when installing a module into a module mounting assembly.

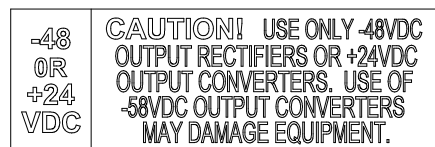


**ALERT!** The system can either have +24V DC-DC converters installed or -58V DC-DC converters installed. The system cannot have both types of converters installed at the same time.



**ALERT!** The -48 VDC to +24 VDC converter modules must only be installed in a system position that accepts a +24V DC-DC converter. Refer to labeling on the system's module mounting shelf. A sample of this labeling is provided in Figure 6.1.

Figure 6.1 Sample Module Mounting Shelf Labeling



**ALERT!** The -48 VDC to -58 VDC converter modules must only be installed in a system position that accepts a -58V DC-DC converter. Refer to labeling on the system's module mounting shelf. A sample of this labeling is provided in Figure 6.2.

Figure 6.2 Sample Module Mounting Shelf Labeling



1. Unpack the modules.
2. Note the model number located on the front of each module. Model numbers starting with the letter “R” are rectifier modules. Model numbers starting with the letter “C” are converter modules. Model numbers starting with the letter “S” are solar converter modules.
3. Place the module into an unoccupied mounting position without sliding it in completely. Each module mounting assembly may house rectifier modules, optional solar converter modules, optional -48 VDC to +24 VDC converter modules or optional -48 VDC to -58 VDC converter modules, and a controller (depending on configuration).



**NOTE!** Refer to the module position identification label located either on the inside of the distribution cabinet door (rack mounted systems) or inside the OSP cabinet when no door is furnished for acceptable rectifier, solar converter, optional -48 VDC to +24 VDC converter module, and optional -48 VDC to -58 VDC converter modules mounting positions in the specific module mounting assembly(s) contained in your system. See Figure 5.6.



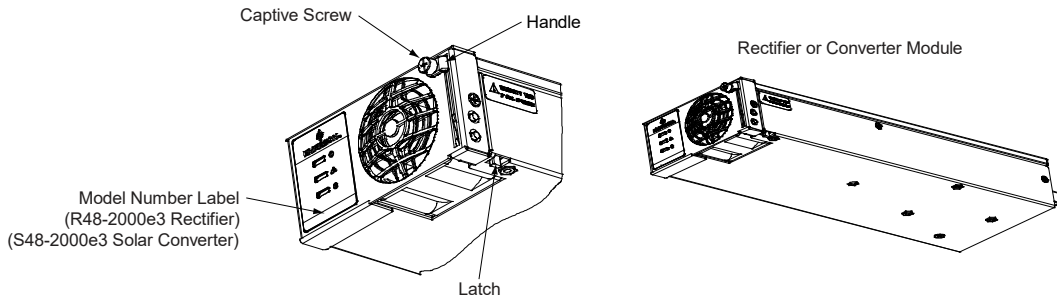
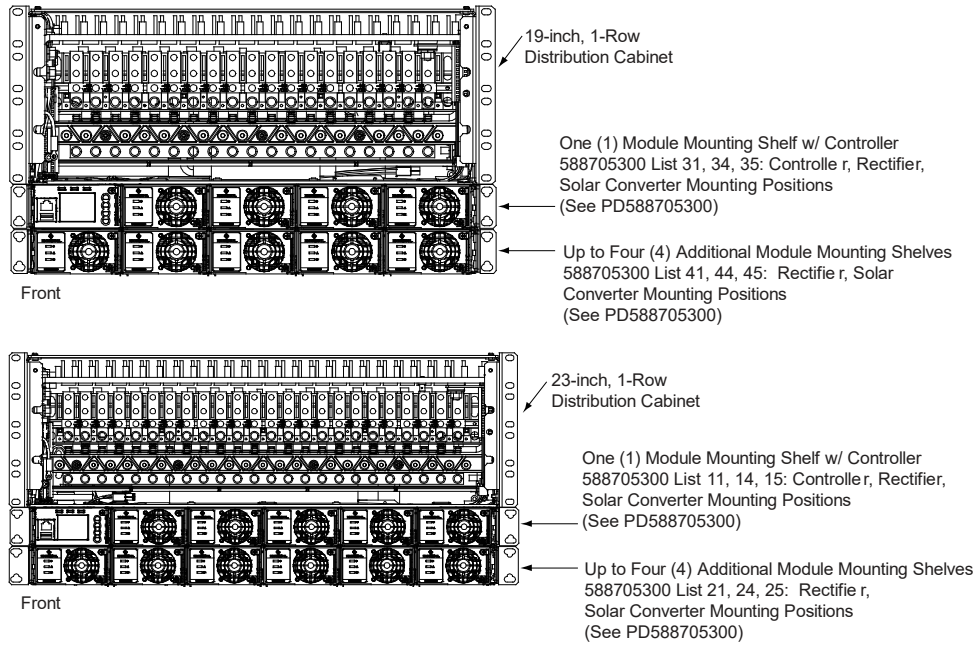
**NOTE!** See PD588705300 for additional acceptable module position details.



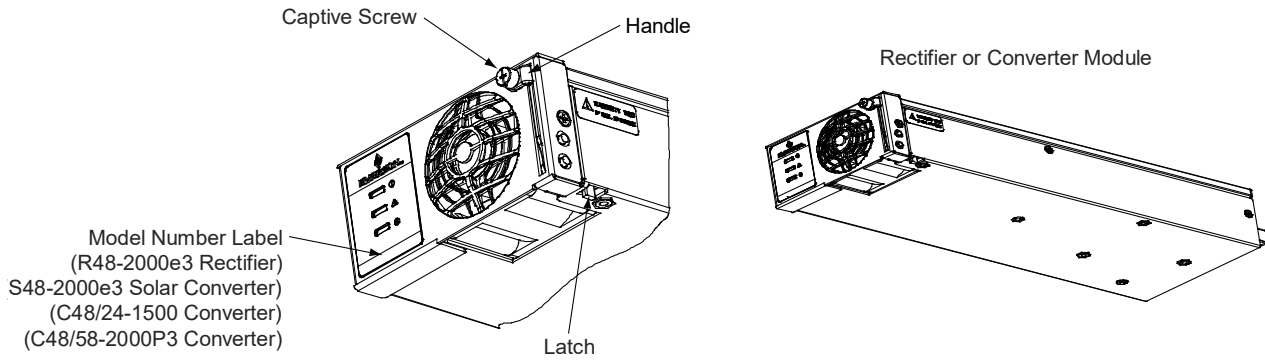
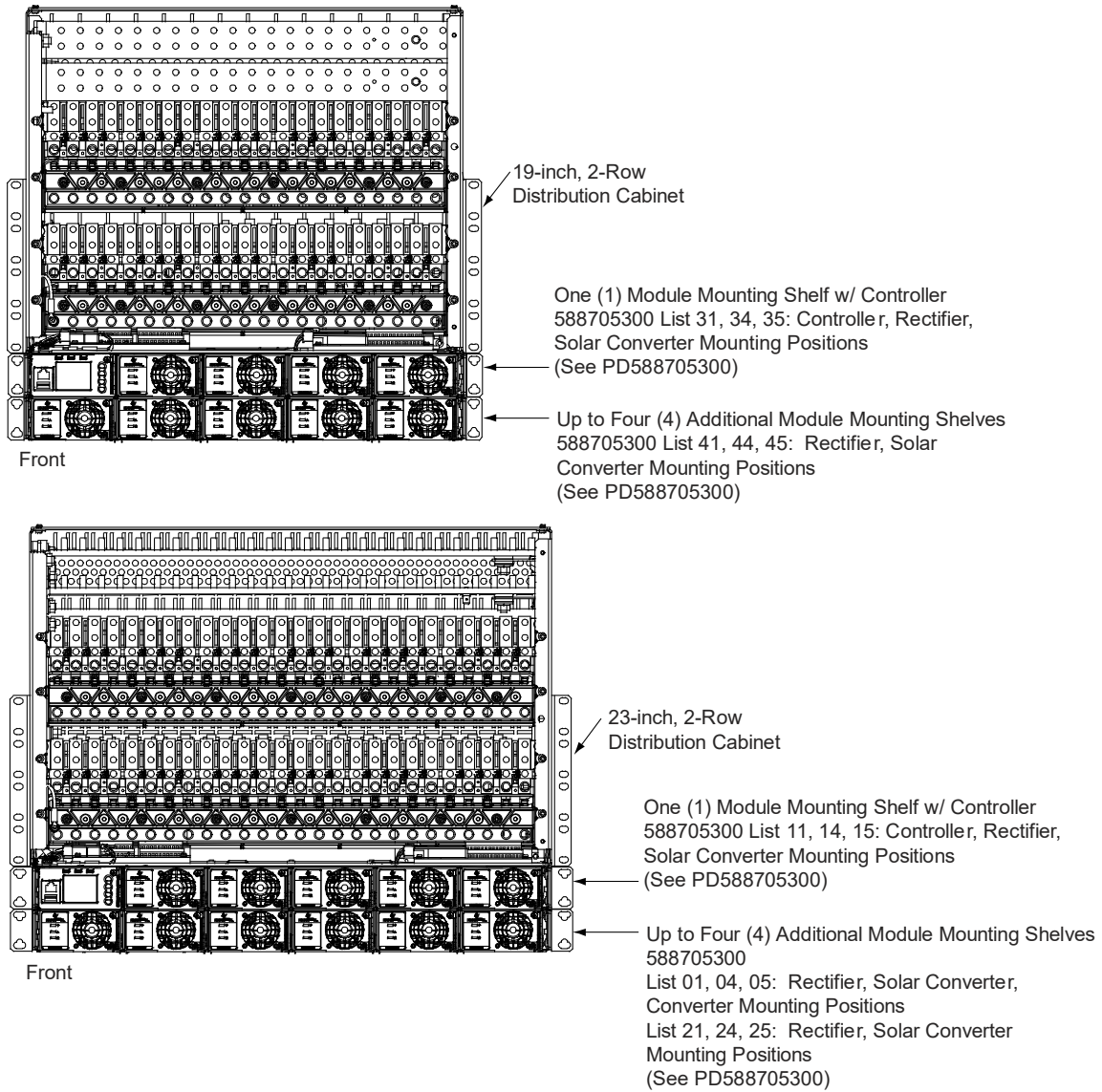
**NOTE!** Refer to the NOTE on page 155 regarding restrictions when using an AC feed option where each feed connects to two (2) slots in the shelf (List 46 or Molex connected cords) and -48 VDC to +24 VDC converters or -48 VDC to -58 VDC converters are being used (List 26 two row distribution panel or List 27 single row distribution panel).

4. Loosen the captive screw on the module’s handle. Pull the handle down out from the module’s front panel (this will also retract the latch mechanism). See Figure 6.3, Figure 6.4, or Figure 6.5.
5. Push the module completely into the module mounting assembly.
6. Push the handle up into the module’s front panel. This will lock the module securely to the module mounting assembly. Tighten the captive screw on the handle.
7. Repeat the above steps for each module being installed in the system.
8. After the modules are physically installed in the mounting module mounting assembly(s), they are ready for operation immediately after power is supplied to them.

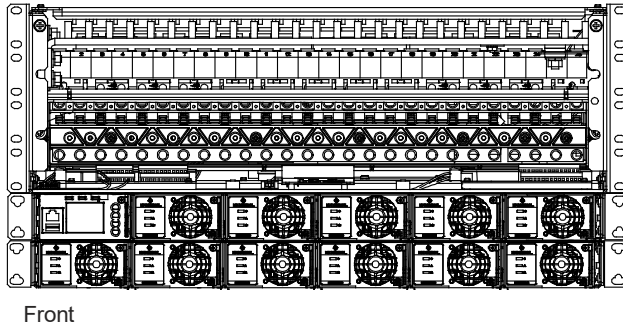
**Figure 6.3 Installing Rectifier and Solar Converter Modules (List 20, 25)**



**Figure 6.4** Installing Rectifier, Solar Converter, and Converter Modules (List 21, 26)



**Figure 6.5** Installing Rectifier and Converter Modules (List 27)

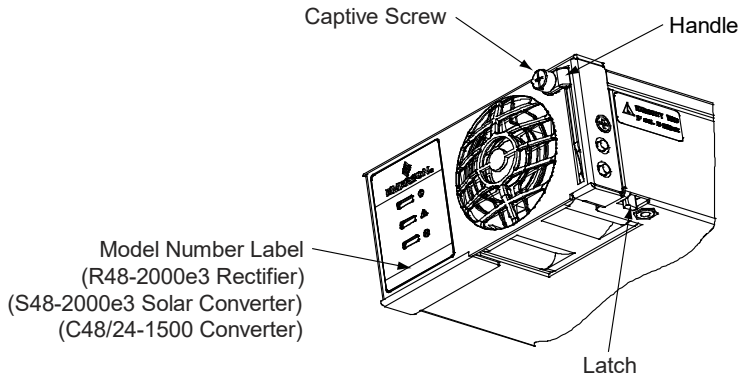


23-inch, 1-Row  
Distribution Cabinet

One (1) Module Mounting Shelf w/ Controller  
588705300 List 11, 14, 15: Controller, Rectifier,  
Solar Converter Mounting Positions  
(See PD588705300)

Up to Four (4) Additional Module Mounting Shelves  
588705300  
List 01, 04, 05: Rectifier, Solar Converter,  
Converter Mounting Positions  
List 21, 24, 25: Rectifier, Solar Converter  
Mounting Positions  
(See PD588705300)

Front

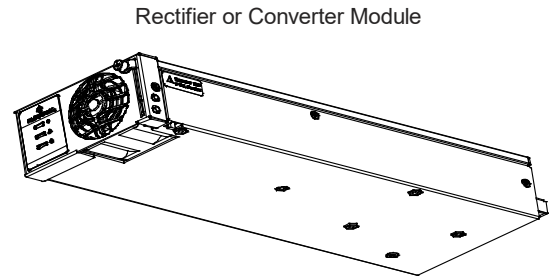


Captive Screw

Handle

Model Number Label  
(R48-2000e3 Rectifier)  
(S48-2000e3 Solar Converter)  
(C48/24-1500 Converter)

Latch



Rectifier or Converter Module

## 6.2 Installing Inverter Module in Inverter Module Mounting Assembly (If Equipped with Optional Inverter System)

Inverter modules can be inserted or removed with power applied (hot swappable).



**NOTE!** Each inverter module locks into the module mounting shelf by means of a latch located on the bottom of the inverter module. The latch and inverter module handle are interactive. Pushing the handle up into the inverter module's front panel causes the latch to extend to the locking position; pulling the handle down out from the inverter module's front panel causes the latch to retract. See Figure 6.6.

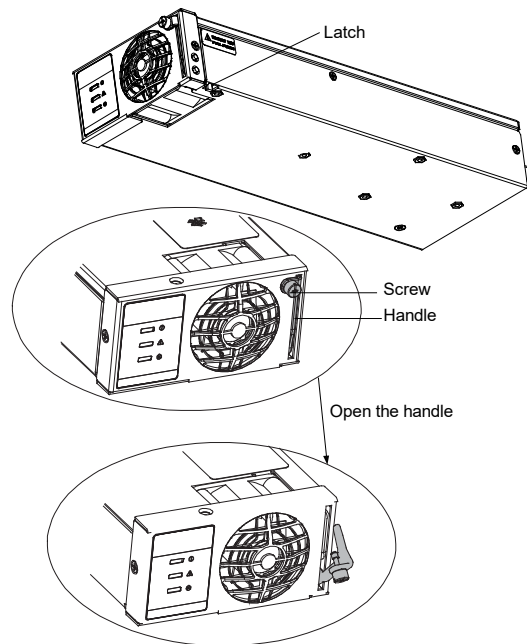


**WARNING!** To prevent damage to the latching mechanism, ensure the handle is in the open position when installing or removing an inverter module. NEVER hold the handle in the closed position when installing an inverter module into a shelf.

### Procedure

1. Unpack the inverter modules.
2. If present, remove blank cover panels from the module mounting positions into which inverter modules are to be installed.
3. Place the inverter module into an unoccupied mounting position without sliding it in completely.
4. Loosen the captive screw on the inverter module's handle. Pull the handle down out from the inverter module's front panel (this will also retract the latch mechanism). See Figure 6.6.
5. Push the inverter module completely into the shelf.
6. Push the handle up into the inverter module's front panel. This will lock the inverter module securely to the shelf. Tighten the captive screw on the handle.
7. Repeat the above steps for each inverter module being installed in the system.
8. After the inverter modules are physically installed in the mounting shelf(s), they are ready for operation immediately after power is supplied to them.

Figure 6.6 Installing Inverter Modules





## 7 Initially Starting, Configuring, and Checking System Operation



**CAUTION!** Performing various steps in the following procedures may cause a service interruption and/or result in the extension of alarms. Notify any appropriate personnel before starting these procedures. Also, notify personnel when these procedures are completed.

### 7.1 Initial Startup Preparation

- Ensure that all blocks (except the last one) in the Installation Acceptance Checklist on 2 have been checked.
- Ensure that module mounting positions are filled by a rectifier module, solar converter module, -48 VDC to +24 VDC converter module, or -48 VDC to -58 VDC converter module, and inverter module as required. It is acceptable for positions to be left vacant.
- Refer to the separate NCU User Manual supplied with your power system for complete controller operating information.
- Refer to the configuration drawing (C-drawing) supplied with your power system documentation for factory settings of adjustable parameters.

### 7.2 Initially Starting the System

#### **Procedure**

1. Apply battery power to the system by closing the external battery disconnect(s) or protective device(s) that supplies battery power to the system, if furnished. Close the system's internal battery disconnect circuit breakers, if furnished.
2. Apply rectifier and inverter system (if equipped) AC input power to the system by closing ALL external AC disconnects or protective devices that supply AC power to the rectifier module mounting assemblies and inverter system (if equipped). Rectifiers, -48 VDC to +24 VDC converters or -48 VDC to -58 VDC converters (if furnished), and inverters (if furnished) automatically start.



**NOTE!** By default, the inverter runs in AC Mode. Refer to the NCU Instructions (UM1M830BNA) to change this mode, if required.

3. Apply solar converter DC input power to the system (if required) by closing ALL external DC disconnects or protective devices that supply solar converter DC power to the module mounting assemblies. Solar converters (if furnished) automatically start. Close the system's internal solar converter input circuit breakers, if furnished.



**NOTE!** After startup, verify that the controller is configured to the correct solar operating mode (disabled, rect-solar, solar). Refer to "Configuring the Controller for Rect/Solar Mode when Solar Converters are Furnished" on page 167. The controller will not recognize solar converters when the solar mode is disabled.

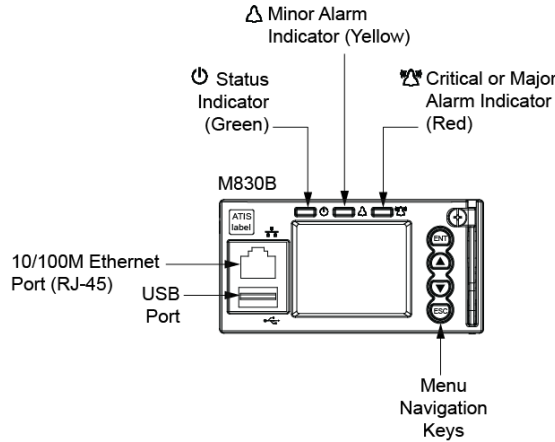
4. Open the distribution cabinet's front door. Place each distribution circuit breaker (if furnished) to the ON position.
5. Place each circuit breaker located on the AC distribution shelf(s) to the ON position (if equipped with optional inverter system).

### 7.3 NCU Controller Initialization

Refer to the NCU Instructions (UM1M830BNA) for detailed instructions.

Refer to Figure 7.1 for locations of the NCU local indicators and navigation keys.

**Figure 7.1 NCU Local Indicators and Navigation Keys**

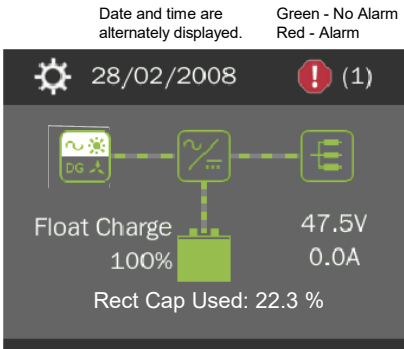


**Procedure**

**NOTE!** The initialization routine takes several minutes. During that time various alarm indicators may illuminate on the NCU front panel and an audible alarm may sound. Disregard all alarms. An audible alarm can be silenced at any time by momentarily depressing the **ENT** key on the NCU Controller.

1. After the NCU is powered on, the display shows the “logo” screen. The controller is initializing.
2. When initialization is complete, the language screen appears. Press the up or down arrow key to select the desired language. Press the **ENT** key to confirm the selection.
3. The Main Menu displays.

**Main Menu**



Date and time are alternately displayed. Green - No Alarm Red - Alarm

Press the UP and DOWN keys to highlight the desired Menu graphic in the Main Menu. Press the ENT key to enter the selected menu.

The number in ( ) indicates the total number of alarms.

Graphics	Menu Name	Description
	Alarm (Green - No Alarm) (Red - Alarm)	View active alarms and alarm history.
	Settings	Gain access to the NCU Controller's settings menus.
	Input Power	View AC, Solar, DG, and Wind related information.
	Module	View rectifier, solar converter, and converter module related information.
	DC	View DC equipments related information.
	Battery	View battery related information.

To reboot the Controller, from the Main Menu press the ENT and ESC keys at the same time. Release both keys. Press ENT to confirm.

4. System information is displayed in multiple screens. Press the ESC key to view other system information. Press the down arrow key to view the next screen. Press the ESC key to return to the Main Menu.

- From the Main Menu, press the UP and DOWN keys to highlight the desired Menu graphic in the Main Menu. Press the ENT key to enter the selected menu.



**NOTE!** Repeatedly press the “ESC” key to return in reverse order level by level from any submenu until the Main Menu appears.

- Refer to the following procedures to verify and set the NCU controller as required for your application.

## 7.4 Verifying and Setting the NCU Controller as Required for Your Application



**NOTE!** If equipped with optional inverter system, the NCU is factory configured for use with this inverter system and no adjustment is required.

Refer to the NCU Instructions (UM1M830BNA) for additional information.

Note that you will have to program the NCU for any temperature probes and external inputs/outputs connected to the IB2 Interface Board and optional EIB Extended Interface Board.

Refer also to “NCU Start Wizard” on page 163.



**NOTE!** When setting total rectifier current limit, the set point to each unit is the total set point divided by the number of units. For example, if the system contains five rectifiers and the current limit is set to 150 amps then each rectifier has a current limit set point of 30 amps. If one or more rectifiers are removed or fail, it will take several seconds for the individual set points to the remaining rectifiers to be reset. In the example given, if one rectifier is removed the current limit set point will drop to 120 amps (30 amps times four remaining rectifiers) until the controller can send updated set points to the remaining rectifiers. This takes a couple communication cycles (several seconds) after which each rectifier would have a new set point of 37.5 amps for a total of 150 amps. The total current limit of the rectifiers should not be set such that the loss of the redundant rectifiers will cause this temporary set point to drop below the actual maximum expected load. If batteries are used on the rectifier output, the batteries should support the load until the current limit set points can be re-established due to loss of a rectifier.

### **NCU Start Wizard**

For initial startup, you can perform the Start Wizard from the local keypad and display to enter basic programmable parameters in one session. Refer to the “Start Wizard” section in the NCU Instructions (UM1M830BNA).

### **Verifying the Configuration File**

Your NCU was programmed with a configuration file that sets all adjustable parameters. The version number of the configuration file can be found on the configuration drawing (C-drawing) that is supplied with your power system documentation, and on a label located on the NCU. You can verify that the correct configuration file has been loaded into your NCU by performing the following procedure.

#### **Procedure**

- With the Main Menu displayed, press **ESC**. A screen displays the NCU name, serial number, IP number, software version, hardware version, and configuration version number.
- Press **ESC** to return to the Main Menu.

## Checking Basic System Settings

Navigate through the controller menus and submenus to check system settings. You can adjust any parameter as required. Note that these settings can also be checked (and changed if required) via the WEB Interface. Refer also to “NCU Start Wizard” on page 163.



**NOTE!** Repeatedly press the “ESC” key to return in reverse order level by level from any submenu until the Main Menu appears.

### Procedure

1. **To Select a Sub-Menu:**  
Press the UP and DOWN keys to highlight the desired sub-menu. Press the ENT key to enter the selected sub-menu.
2. **To Select a User:**  
To select a User, use the UP and DOWN keys to move the cursor to the Select User field. Press ENT. Use the UP and DOWN keys to select a User previously programmed into the NCU. Press ENT to select the User. Note that only Users programmed into the NCU are shown. Users are programmed via the Web Interface. The default User is admin.
3. **To Enter a Password:**  
If a password screen opens, a password must be entered to allow the User to make adjustments. To enter a password, use the UP and DOWN keys to move the cursor to the Enter Password field. Press ENT. Use the UP and DOWN keys to choose a character. Press ENT to accept and move to the next character. Continue this process until all characters are entered. Press ENT again to accept the password. The default password is 640275.
4. **To Change a Parameter:**  
Press the UP and DOWN keys to move up and down the list of parameters. Press ENT to select the parameter. Press the UP and DOWN keys to change the parameter. Press ENT to make the change. Press ESC to cancel the change.
5. Table 7.1 shows the menu navigation for some basic settings. Refer to the separate NCU Manual (UM1M830BNA) supplied with your power system for complete Local Display menus.

Table 7.1 NCU Basic Settings Menu Navigation

Parameter	Menu Navigation
Date	Main Menu / Settings Icon / Sys Settings / Date.
Time	Main Menu / Settings Icon / Sys Settings / Time.
IP Communications Parameters (IP address, subnet mask address, gateway address)	Main Menu / Settings Icon / Comm Settings / enter parameters.
Float Voltage	Main Menu / Settings Icon / Batt Settings / Charge / Float Volt(R).
Equalize Voltage	Main Menu / Settings Icon / Batt Settings / Charge / EQ Voltage(R).
Converter Output Voltage	Main Menu / Settings Icon / Other Settings / Conv Volt Set.
Converter Current Limit	<b>Web Menu Navigation Only:</b> Settings Menu / "DC/DC" Converter Tab / Current Limit and Current Limit Point.
Solar Converter Output Voltage	Main Menu / Settings Icon / Batt Settings / Charge / Float Volt(S) and EQ Voltage(S).
Solar Converter Current Limit	<b>Web Menu Navigation Only:</b> Settings Menu / Solar Tab / Solar Converter Current Limit.
Battery Current Limit	Main Menu / Settings Icon / Batt Settings / Curr Limit Mode and Batt Curr Limit.
Battery Capacity	Main Menu / Settings Icon / Batt Settings / Batt1 Settings / Rated Capacity.
BTRM Feature	<b>Web Menu Navigation Only:</b> Settings Menu / Battery Tab.
Battery Charge Temperature Compensation	Main Menu / Settings Icon / Batt Settings / Temp Comp (enter parameters).
HVSD Limit	<b>Web Menu Navigation Only:</b> Settings Menu / Rectifiers Tab / HVSD (set to enabled) then set HVSD Limit.
Rectifier Current Limit	Main Menu / Settings Icon / Rect Settings / Current Limit (set to enabled) then set Curr Limit Pt.
Over Voltage Alarm 1	Main Menu / Settings Icon / Other Settings / Over Voltage 1.
Over Voltage Alarm 2	Main Menu / Settings Icon / Other Settings / Over Voltage 2.
Under Voltage Alarm 1	Main Menu / Settings Icon / Other Settings / Under Voltage 1.
Under Voltage Alarm 2	Main Menu / Settings Icon / Other Settings / Under Voltage 2.

### Changing Battery Capacity Rating in the NCU

1. Change the battery capacity setting of the NCU to match the battery connected to the power system.



**NOTE!** After setting the battery capacity, the User should also reset the battery capacity (battery must be fully charged).

#### Local Menu Navigation:

Main Menu / Settings Icon / Batt Settings / Batt1 Settings / Rated Capacity.

#### Web Menu Navigation:

Settings Menu / Battery Tab / Batt1 Rated Capacity.

2. Reset the battery capacity (resets the battery capacity calculation).



**NOTE!** Only reset the battery capacity when the battery is fully charged; otherwise, the battery charge status may not be accurate.

#### Local Menu Navigation:

Main Menu / Settings Icon / Batt Settings / Basic Settings / Reset Batt Cap.

#### Web Menu Navigation:

Settings Menu / Battery Tab / Reset Battery Capacity.

Refer to the NCU Instructions (UM1M830BNA) for detailed instructions.

### **Configuring the NCU Identification of Rectifiers and Assigning which Input Feed is Connected to the Rectifiers**

When rectifiers are all installed prior to applying power and starting the system, the order in which the NCU identifies the rectifiers is by serial number (lowest serial number is Rect 1, next lowest is Rect 2, etc.). If you prefer the NCU to identify the rectifiers by position in the system, perform the following procedure.

Upon power up, the NCU arbitrarily assigns Feed AC1, AC2, or AC3 to each rectifier. This assignment is used to display rectifier AC input feed voltage(s). The User may reassign the feed to each rectifier per your specific installation by following the procedure below.

#### **Local Menu Navigation:**

None.

#### **Web Menu Navigation:**

Refer to the NCU Instructions (UM1M830BNA) for detailed instructions.

### **Configuring the NCU Identification of Solar Converters**

When solar converters are all installed prior to applying power and starting the system, the order in which the NCU identifies the solar converters is by serial number (lowest serial number is Solar Conv 1, next lowest is Solar Conv 2, etc.). If you prefer the NCU to identify the solar converters by position in the system, perform the following procedure.



**NOTE!** See also “Configuring the Controller for Rect/Solar Mode when Solar Converters are Furnished” on page 167.

#### **Local Menu Navigation:**

None.

#### **Web Menu Navigation:**

Refer to the NCU Instructions (UM1M830BNA) for detailed instructions.

### **Configuring the NCU Identification of -48 VDC to +24 VDC Converters or -48 VDC to -58 VDC Converters**

When -48 VDC to +24 VDC converters or -48 VDC to -58 VDC converters are all installed prior to applying power and starting the system, the order in which the NCU identifies the -48 VDC to +24 VDC converters or -48 VDC to -58 VDC converters is by serial number (lowest serial number is Conv 1, next lowest is Conv 2, etc.). If you prefer the NCU to identify the -48 VDC to +24 VDC converters or -48 VDC to -58 VDC converters by position in the system, perform the following procedure.

#### **Local Menu Navigation:**

None.

#### **Web Menu Navigation:**

Refer to the NCU Instructions (UM1M830BNA) for detailed instructions.

### **Configuring the NCU Identification of Inverters**

When inverters are all installed prior to applying power and starting the system, the order in which the NCU identifies the inverter is by serial number (lowest serial number is Inv 1, next lowest is Inv 2, etc.). If you prefer the NCU to identify the inverters by position in the system, perform the following procedure.

#### **Local Menu Navigation:**

None.

#### **Web Menu Navigation:**

Refer to the NCU Instructions (UM1M830BNA) for detailed instructions.

## **NCU Alarm Relay Check**

To verify operation of the external alarm relays, use the NCU alarm relay test feature. Refer to the NCU Instructions (UM1M830BNA) for instructions in using this feature.



**NOTE!** *The relays may be preprogrammed for specific functions. Refer to the configuration drawing (C-drawing) supplied with your system for your system's specific configuration.*

## **Configuring the Shunt Channels for a Hybrid Connection Cabinet (SM-DU)**

### **Procedure**

1. Refer to "Setting Shunts (Connected to the SM-DU Assembly)" in the NCU Instructions (UM1M830BNA).

## **Configuring the Controller for Rect/Solar Mode when Solar Converters are Furnished**

### **Enabling Solar Mode Procedure**

#### **Local Menu Navigation:**

None.

#### **Web Menu Navigation:**

Settings / Power System / Solar Mode / set to "SOLAR" or "RECT-SOLAR" or "Disabled".

- **RECT-SOLAR:** If you have both rectifiers and solar converters in the system, set Solar Mode to "RECT-SOLAR". Also set the "Float Charge Voltage (Solar)" parameter to the desired float setting. The parameter "Float Charge Voltage (Rect)" setting **MUST** be set 0.5 V lower than the "Float Charge Voltage (Solar)" parameter setting for solar converters to operate properly.
- **SOLAR:** If you have only solar converters in the system, set Solar Mode to "SOLAR". Also set the "Float Charge Voltage (Solar)" parameter to the desired float setting.


















**NOTE!** *When solar converters are all installed prior to applying power and starting system, the NCU will NOT communicate with solar converters until SOLAR MODE is enabled.*

## 7.5 Checking System Status

### Procedure

1. Observe the status of the indicators located on the controller, rectifiers, solar converters, -48 VDC to +24 VDC converters or -48 VDC to -58 VDC converters (if furnished), and inverters (if furnished). If the system is operating normally, the status of these is as shown in Table 7.2.

**Table 7.2 Status and Alarm Indicators**

Component	Indicator	Indicator	Normal State
NCU		Status (Green)	On
		Minor Alarm (Yellow)	Off
		Critical or Major Alarm (Red)	Off
Rectifier Modules		Power (Green)	On
		Protection (Yellow)	Off
		Alarm (Red)	Off
Solar Converter Modules		Power (Green)	On
		Protection (Yellow)	Off
		Alarm (Red)	Off
-48 VDC to +24 VDC Converter Modules and -48 VDC to -58 VDC Converter Modules		Power (Green)	On
		Protection (Yellow)	Off
		Alarm (Red)	Off
Inverter Modules		Power (Green)	On
		Protection (Yellow)	Off
		Alarm (Red)	Off



## 7.6 Final Steps

### **Procedure**

1. If any controller configuration settings were changed, refer to the NCU Instructions (UM1M830BNA) and save a copy of the configuration file. This file can be used to restore the controller settings, if required, at a later date.



**NOTE!** *Provided on a USB drive furnished with the system is a controller configuration drawing (C-drawing) and the controller configuration files loaded into the controller as shipped.*

2. Close and secure the distribution cabinet's front door.
3. Verify all rectifier, solar converter, converter modules, inverter modules (if equipped with optional inverter system) and the controller are fully seated, latched, and the latch handle screws secured.
4. Verify there are no external alarms, and the local indicators are as shown in Table 7.2.

This page intentionally left blank.

**Connect with Vertiv on Social Media**



<https://www.facebook.com/vertiv/>



<https://www.instagram.com/vertiv/>



<https://www.linkedin.com/company/vertiv/>



<https://www.twitter.com/vertiv/>



---

Vertiv.com | Vertiv Headquarters, 505 N Cleveland Ave, Westerville, OH 43082, USA

© 2023 Vertiv Group Corp. All rights reserved. Vertiv™ and the Vertiv logo are trademarks or registered trademarks of Vertiv Group Corp. All other names and logos referred to are trade names, trademarks or registered trademarks of their respective owners. While every precaution has been taken to ensure accuracy and completeness here, Vertiv Group Corp. assumes no responsibility, and disclaims all liability, for damages resulting from use of this information or for any errors or omissions.