



Liebert®

AF2

Next Generation Active Harmonic Filter



You Need To Be Aware Of Harmonics

During the last few years industries has witnessed an increasing awareness of clean power, power system harmonics and associated problems in low-voltage systems, both in power utilities and consumer segment. Harmonics being one of the major contributors of poor power quality, a better understanding is essential to minimize it's effects.

...Because Today's Systems Are Getting More Diverse

As the business processes and manufacturing facilities become more and more automated, new equipment either replaces or augments functions that were previously done manually. In today's complex and diverse electrical environment, achieving system compatibility is often a steep challenge.

...Because Today's Equipment Is More Sensitive

Modern IT facilities, Data centers, Telecommunication equipments, Industrial processes and Medical equipment rely on sophisticated electronics for precise and continuous control, and the sensitivity of such electronics can jeopardize process reliability.

...Because You Need To Protect Your Facility

The different levels of harmonics generated by such sensitive equipment cause concern to the facility engineers. The power system pollution created by them can lead to damage of other equipment with consequent loss of production or network down time. When equipment and appliances get along in the same electrical environment, they are said to be in a state of system compatibility. It is essential to understand all the equipment in a facility to achieve system compatibility.

What are Harmonics?

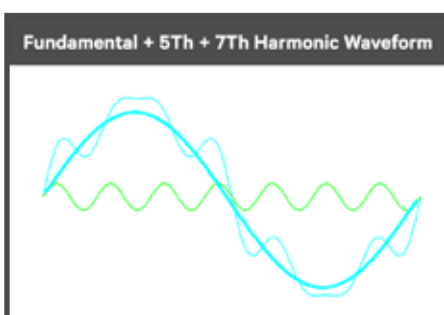
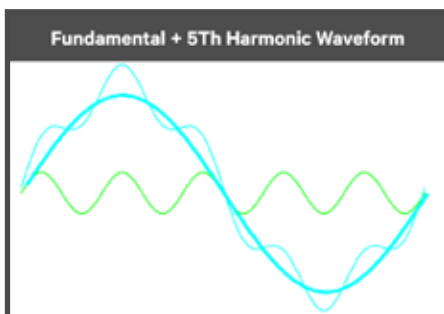

LIEBERT® AF2 TRUE HARMONICS SOLUTION

- Active Harmonic Compensation
- Reactive Power Compensation
- Improved Power Quality
- Easy Selection & Installation
- Minimum Losses
- Modular, Scalable Architecture for Easy up-gradation
- Ranges from 35A to 960A

Harmonics are periodic, sinusoidal & integer multiples of fundamental frequency (50 or 60Hz), current or voltage components, present in non-sinusoidal waveform.

It distorts pure sinusoidal waveform and turns it to a non-sinusoidal waveform.

Current Harmonics are Load generated components and usually have effect on Voltage waveform and make it non-sinusoidal.

Voltage Harmonics are predominantly by-products of current harmonics except for few occasions, where a power is generated out of DC voltages or low capacity generators.

Harmonics can only be measured by electronic measurement devices.

Does Your Facility Have A Harmonics Problem?

Today's Modern Offices, Data centers and Manufacturing plants often faces unique problems which leads to loss of Business Critical Continuity. Some of commonly faced problems are:

- Transformers getting overheated while supplying seemingly average loads
- Audible noise / hum in transformers
- Significant Transient activity in supply system
- Decreasing distribution capacity due to hot cables
- Excessive N-G voltages
- Neutral conductors in 3-Phase balanced circuits getting overheated and / or burnt
- Circuit breakers are tripping for no apparent reason
- Failure of PF improvement capacitors
- Interference in telecommunication equipments
- Generator Hunting
- Electronic Control Clock errors
- Quivering Monitors and CRT displays
- Supply Voltage distortion and lagging power factor
- And many more

Yet, the standard trouble shooting procedures show everything to be normal!

Which Equipment in your facility is responsible?

Harmonics are the by-products of Modern facilities and Electronic equipment. These are called often called non-linear loads. Examples of such loads are:

- Servers, Computers, PCs, Printers and other IT Equipment (Having Switch Mode Power Supplies)
- Controlled Rectifiers, Battery Chargers, Uninterrupted Power Supply (UPS) systems
- Phase controlled AC voltage regulators
- Compact Fluorescent Lamps, Fan regulators
- Traction Equipment
- Arc Furnaces or Induction Furnaces, Welding Machines
- Adjustable Speed AC and DC Variable speed motor drives
- PLC, DCS and SCADA systems (SMPS)
- Solid State Heater Controls
- HVDC sending and receiving end equipment



Flow of Harmonics

- In an electrical system, the harmonics are not typically generated in the generator except in case of small generators.
- If by chance the supply system has harmonics, then on a linear load (purely resistive, capacitive & inductive load), there will be harmonic currents produced in the load. Under these conditions, direction of flow of the harmonic power is then downstream.
- On the contrary, even if the supply voltage is purely sinusoidal and of fundamental frequency (50 Hz or 60Hz) and the load is nonlinear, harmonic currents are generated and due to the line impedance harmonic voltages are developed at the distribution end. Under these conditions the harmonic power flows upstream.

No One Knows Power Protection Better Than Vertiv

- Vertiv has consistently developed the power, cooling and monitoring technologies that IT organizations rely on to manage growth and integrate new technologies.
- From the first precision-cooling system in 1965, to the first enclosed protection system in 1994, to the first high-density cooling system in 2002, Vertiv's Liebert® technology has given IT organizations the reliability and flexibility they need to succeed.
- That's why every company in the Fortune 500 uses Vertiv. And they are not alone: 497 of the Information Week 500, 97 of the Computerworld Premier 100, and hundreds of thousands of small and midsize organizations around the world use Liebert® technology to protect business-critical systems.
- Through joint research and technology sharing, Vertiv is taking critical availability to new levels and enabling organizations like yours to achieve their business continuity objectives.

Our Integrated Solutions

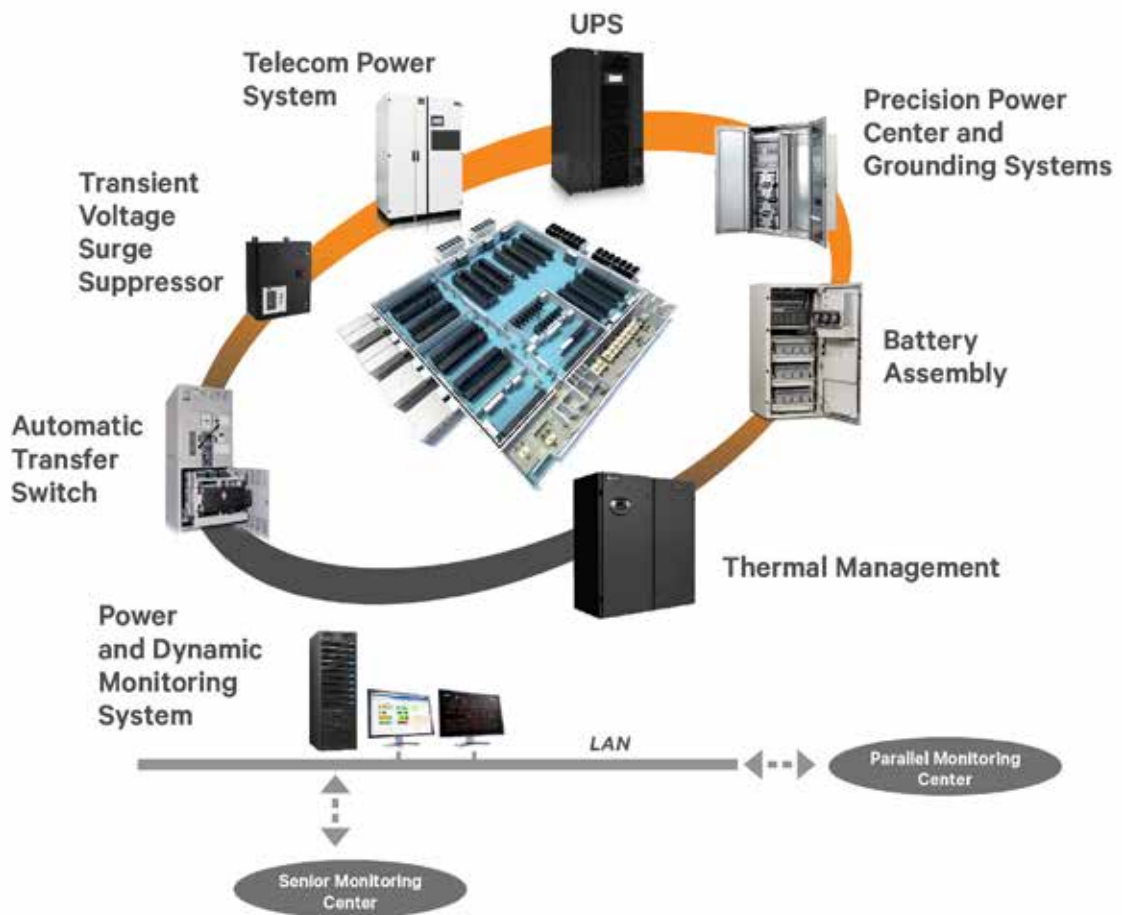

Liebert®, by virtue of its prolonged experience in power quality field, offers various solutions to protect equipments from load generated harmonics. Some of these solutions are:

- Active harmonic solution with Liebert® AF2 which are used for UPS or Non-UPS applications. This not only protects your systems from harmonic problems but also can be used to improve displacement power factor which maximize your active power usage.
- Different kinds harmonic trap filters (compensated or uncompensated) in front of Liebert® UPS systems.
- Different configurations of Isolation transformers to trap certain orders of harmonics in a distribution system.
- Certain Combinations of above.

LIEBERT® AF2

Active Harmonics Solution

While there are many ways to reduce the harmonic effect in a distribution system correcting harmonic effect through incorporation of active harmonic filter is regarded as one of the best methods.



Liebert® AF2, the next generation active harmonics solution, is a solid-state power converter that brings you the ultimate Power Quality Solution from harmonic problems to ensure your facility's Business-Critical Continuity:

With a true active filter design, Liebert® AF measures the harmonics generated from the non-linear loads and cancel them with its own generated, opposite phase shifted harmonic current of the same amplitude.

Selection of Liebert® AF depends on the level of correction needed by distribution system from the view point of Load THDi (Current Harmonics) and Power factor. There is no need to measure the impedance of the power system or analyze the load harmonic spectrum and their individual amplitude.

Wide variety of Choices:

Liebert® AF2 now comes with variety of mounting choices.

- 19" rack mount options
- Wall mount options
- Floor mount options

In case you need any support to size the Active Filter rating, please call Vertiv Quality Experts who will be at your door steps to select proper product for you. Else, please ask for Liebert® AF Ready selection Chart to select on your own.

LIEBERT® AF2 TRUE HARMONICS SOLUTION

- Active Harmonic Compensation
- Improved Power Quality
- Easy Selection & Installation
- Minimum Losses
- Scalable Architecture for Easy up-gradation
- Ranges from 25A

Benefits of Liebert® AF2

Improved Current Harmonics and Power Factor

Unique Design of Liebert® AF 2 compensates current harmonics up to 51st Order and thus reduces Load harmonics, reflected to source, to less than 3% and thus improves lagging power factor from Non-Linear loads. The Current wave form, as seen by Source (Generator or Transformer), is nearly Sinusoidal with a very high dynamic correction rate under sudden load increase or decrease. Thus it helps reduction in Cable rating, Switchgear rating, upstream transformer & generator rating. It also protects critical loads connected on the upstream power distribution from various harmonic caused disturbances. Add Pictures of wave forms that you included in 'Instantaneous Dynamic Response'.

Easy to deploy. Set and Forge

Liebert® AF2 requires Current transformers (CT) connected on load side to detect & compensate the harmonic components. Connect the Power terminals on the incoming source and feed the CT inputs to Liebert® AF. It will take care of the rest. The Ultra-Reliable Liebert® AF increases the overall reliability of your critical power systems. Even in an Overload state, when load harmonics are greater than the rating of the Liebert® AF, the system will operate in full compensation mode without tripping or bypassing. This will ensure the total power system will operate with only a slightly elevated level of harmonics until additional capacity can be installed.

Easy to Install, Fit & forget

Liebert® AF2 requires Current transformers (CT)*, connected on load side or Source side to detect & compensate load generated harmonic components. Connect the Power terminals on the incoming source and feed the CT inputs to Liebert® AF. It will take care of the rest. High degree of Reliability of Liebert® AF2 ensures Zero down time of your critical loads. Even under over load condition when load harmonics is more than the Liebert® AF2 rating it operates in Full compensation mode without getting tripped except for the fact that the desired level of compensation will not be achieved.

Compatible to Work with Liebert® UPS systems:

Liebert® AF2 is designed to work in tandem with all Liebert® UPS systems, 50Hz or 60Hz, to provide optimum harmonic solutions for your Power system distribution. Please contact Vertiv Quality Expert for optimum solution, required for your facility.

Close Loop or Open loop Control enables perfection in harmonic compensation based on applications

Digital technology of Liebert® AF2 offers adaptive harmonic compensation in variety of applications. It can be configured to operate both in open loop or close loop mode that helps users with flexible operations and enable best performance of Liebert® AF2 that suits their requirements.

Scalable,Adaptable

Has your load harmonic current increased due to change in load or additional load? Do not worry. The modular, scalable design of as Liebert® AF2.

Easy Monitoring and Control

Liebert® AF2 is optionally fitted with Large Screen, Blue Black light LCD display which enables the users to monitor, set and control it. You can have ready reference of all parameters, waveforms harmonic spectrum for managing power quality of your harmonic generating loads. It gives you easy access to monitor load, source & Liebert® AF. Users can easily monitor and understand complicated parameters of harmonic, power factor, voltage, current, frequency and kVA. Even log, status & alarm with buzzer help users to take corrective steps at much ease. As a standard feature, Liebert® AF is fitted with LED display with user friendly control panel.



Digital Technology:

DSP controlled Liebert® AF2 ensures precise control of its performance, stable, user friendly operations and improved dynamic response. The same Liebert® AF2 can now be used for both 3 phase 3 wire and 3 phase 4 wire applications.

Remote monitoring and easy Communication Capability:

With an array of communications options users are able to monitor this critical piece of equipment locally or from remote locations.

- Liebert® AF2 uses Modbus/J-bus protocol and offers two (2) communication slots that can offer any of following communication cards
 - Standard RS232/USB card
 - Optional RS22/RS485 card
 - Optional Ethernet card
- Dry Contact
 - Programmable five (5) output dry contacts
 - One (1) input dry contact
 - Emergency Power Off (EPO) switch for emergency shut-down
- Optional 'Liebert® AF2 Monitoring Software'
 - Offers local or remote monitoring of your Liebert® AF2 unit/s
 - Monitor up to 255 units
 - Real time monitoring
 - Download parameters, waveforms, harmonic spectrums and event logs
 - Dry contact programming
 - Parameter recorder

Harmonic Attenuation Ratio

The compensation ability of Vertiv's Liebert® AF2 is defined In terms of Harmonic Attenuation Ratio (HAR, I_{lh}/I_{sh}). Typically it is greater than 10

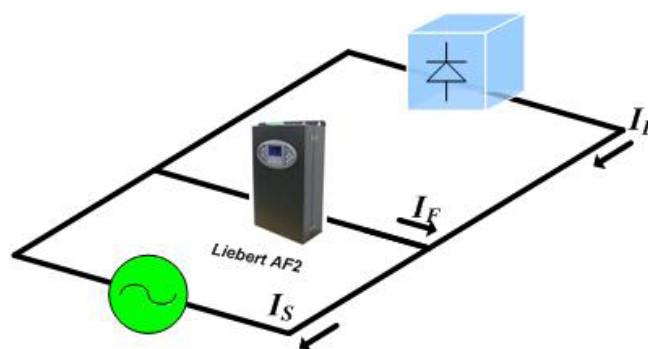

Architecture of the Liebert® AF2

The Liebert® AF2 provides 3 phase harmonic current compensation, with or without neutral compensation. The main components of Liebert® AF are as follows:

- Controller Module
- IGBT controlled Power Converter Modules

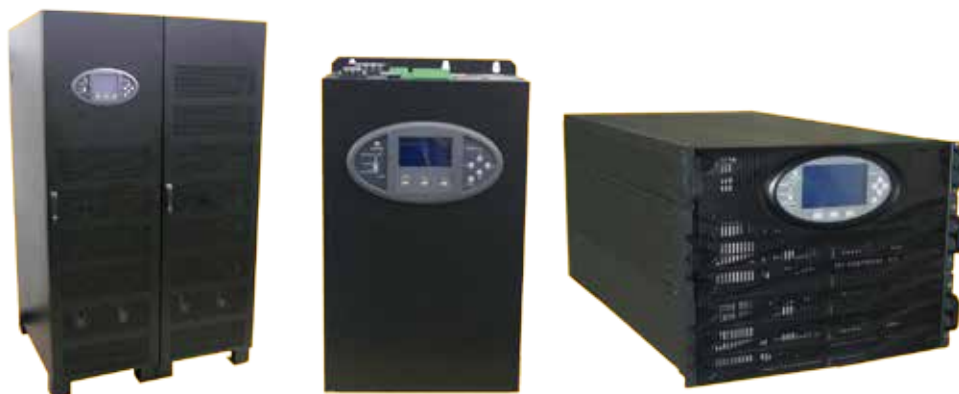

Typical Connection Configuration of Liebert® AF2 with Liebert® UPS systems

A typical 6-pulse rectifier UPS system feeds back 33% Current Harmonics to its source. This may have an adverse effect on Upstream Distribution transformer or generator, depending on their capacity, type and size. Liebert® AF2 of suitable rating, connected in front of such configurations of UPS reduces the THDi to 3% value, improves power factor to 0.98 lagging and thus make the electrical distribution system stable and clean.

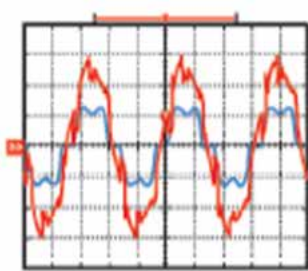
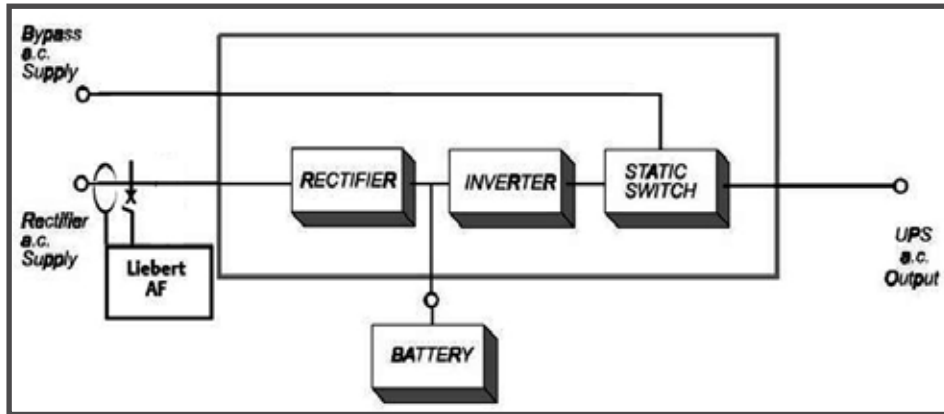

V & Is / Ir
while Liebert® AF2 is off
THDV = 17.4%

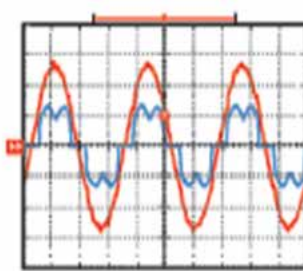

V & Ir
while Liebert® AF2 is on
THDV = 3.1%
THDir= 30.0%

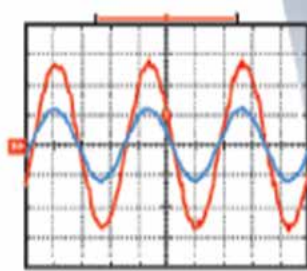

V & Is
while Liebert® AF2 is on
THDIs= 2.5%

Technical Specifications

GENERAL CHARACTERISTICS

Storage Temperature	-20°C ~ +70°C
Operating Temperature	+ 0°C ~ +40°C
Relative Humidity	< 95%
Operating Altitude	<1000 m
Reference Harmonic Standard	EN 61000-3-4 , IEEE 519-1992
Reference Design Standard	EN60146
Safety Standard	EN50178
Electromagnetic Compatibility	IEC 61000-4-2, IEC 61000-4-3, IEC 61000-4-4, IEC 61000-4-5, IEC 61000-4-6

POWER MODULE SPECIFICATION

Input Voltage	400V + 15% , -20% 380V + 21% , -15% 480V or 208V (±10%)
Phase / Wires	3 phase 4 wires/3wires
Frequency	50 / 60 ±3 Hz (Auto Sensing)
Maximum Compensation Current/Phase/Power Module	35 Arms
De-rating Compensation Current/Phase/Power Module (1)	30 Arms
Maximum Compensation Current for Natural/Power Module	105 Arms
Inrush Current	Less than rated current
Current Limitation	Yes, at full correcting
Maximum Heat losses	650 Watt per Power Module
Color	RAL9011 (PANTONE Process Black C)
Ingress Protection	IP20
Dimensions (W x D x H)	440 x 710 x 131mm (3U)
Weight	31 Kg (when unpacked)

When 2 and above Power Modules work in power scalable configuration, the power module will downgrade automatically from 35A to 30A. It means total capacity will be 60A/90A/120A when 2/3/4 400V power modules are connected in parallel.

CONTROL MODULE SPECIFICATION

Input Voltage	400V + 15% , -20% 380V + 21% , -15% 480V or 208V (±10%)
Phase / Wires	3 phase 4 wires / 3wires
Frequency	50 / 60 ±3 Hz (Auto Sensing)
Compensated Harmonic Orders	From 2nd to 51st order.
Individual Harmonic Order selectable up to 12 orders (2nd ~31st), that works simultaneously.	30 Arms
Higher Order Group Harmonic Compensation (32nd-51st) by Disable/Enable function.	105 Arms
Power Factor Correction	Compensate both lagging and leading reactive power.
Power factor can be programmed from 0.7 lagging to 0.7 leading	Yes, at full correcting
CT Ratio	Can be set.
Primary Current: 100A~10000A	RAL9011 (PANTONE Process Black C)
secondary Current: 1A	IP20
CT Location	Source Side for Close Loop Control
Load Side for Open Loop Control	31 Kg (when unpacked)
Harmonic Attenuation Ratio	Typical >10
Response Time	< 20 msec
Number of Power Modules, controllable by one Control Module	Up to 4 Power Modules.
Parallel Operation	Up to 8 Control Modules. The maximum Filter capacity up to 960A.
Maximum Heat losses	50 Watt per Control Module
Color	RAL9011(PANTONE Process Black C)
Ingress Protection	IP20
Dimensions (W x D x H)	440 x 710 x 86mm (2U)
Weight	5 Kg (when unpacked)

For 480V, 208V or other voltage systems, contact Factory for details and support

Technical Specifications

CONTROL PANEL SPECIFICATION

LED Control Panel	<ul style="list-style-type: none"> a. 4 Status LED indicators: POWER ON, FILTERING, FULL CORRECTING and ERROR b. ON/OFF and RESET key pads. c. 8 alarm LED indicators Diagnostic Message. d. 4-status LED indicators: POWER ON, FILTERING, FULL CORRECTING and ERROR
LCD Control & Display Panel (Optional)	<ul style="list-style-type: none"> a. 4 Status LED indicators: POWER ON, FILTERING, FULL CORRECTING and ERROR b. ON/OFF and RESET key pads. c. 4 Directional Scrolling Keys/Enter Key/Escape key. d. LCD Display Panel offers following functions: <ul style="list-style-type: none"> • Meter: parameter, waveform and spectrum. • Event Log: Up to 300 records (FIFO). • Configuration: Compensation Setting, Compensation Logic Control and System Setting. • Multi-Language Setting: up to different languages.

COMMUNICATION INTERFACE SPECIFICATION

Dry Contact (Standard Configuration)	<ul style="list-style-type: none"> a. 5 Output Dry Contacts b. 1 Input Dry Contact c. 1 EPO
Communication Interface	Standard: RS232/USB Optional: RS485/RS422 Ethernet Card
Programming	Setting by expert service software or LCD control panel
Monitoring Software (Optional)	Liebert® AF2 Monitoring Software
Communication Protocol	J-Bus/MOD Bus Protocol

FLOOR MOUNT PANEL SPECIFICATION

Maximum Installation Capacity	Panel with Bezel: 180Arms (2 Control Modules + 6 Power Modules) Panel with Bezel: 240Arms (2 Control Modules + 8 Power Modules)
Color	RAL7021
Ingress Protection	IP20
Dimension (WxDxH)	600 x 1000 x 1950mm
Maximum Weight	130 Kg (when unpacked)





VertivCo.com

© 2017 Vertiv Co. All rights reserved. Vertiv, the Vertiv logo are trademarks or registered trademarks of Vertiv Co. All other names and logos referred to are trade names, trademarks or registered trademarks of their respective owners. While every precaution has been taken to ensure accuracy and completeness herein, Vertiv Co. assumes no responsibility, and disclaims all liability, for damages resulting from use of this information or for any errors or omissions. Specifications are subject to change without notice.

Liebert-AF2-BR-EN-Asia-V1