



Liebert® XDU450

Coolant Distribution Unit

Installation and Commissioning Guide

The information contained in this document is subject to change without notice and may not be suitable for all applications. While every precaution has been taken to ensure the accuracy and completeness of this document, Vertiv assumes no responsibility and disclaims all liability for damages resulting from use of this information or for any errors or omissions.

Vertiv recommends installing a monitored fluid detection system that is wired to activate the automatic closure of field-installed coolant fluid supply and return shut off valves, where applicable, to reduce the amount of coolant fluid leakage and consequential equipment and building damage. Refer to local regulations and building codes relating to the application, installation, and operation of this product. The consulting engineer, installer, and/or end user is responsible for compliance with all applicable laws and regulations relating to the application, installation, and operation of this product.

The products covered by this instruction manual are manufactured and/or sold by Vertiv. This document is the property of Vertiv and contains confidential and proprietary information owned by Vertiv. Any copying, use, or disclosure of it without the written permission of Vertiv is strictly prohibited.

Names of companies and products are trademarks or registered trademarks of the respective companies. Any questions regarding usage of trademark names should be directed to the original manufacturer.

Technical Support Site

If you encounter any installation or operational issues with your product, check the pertinent section of this manual to see if the issue can be resolved by following outlined procedures.

Visit <https://www.vertiv.com/en-us/support/> for additional assistance.

TABLE OF CONTENTS

1 Important Safety Information	1
1.1 General	5
1.2 Installation/Handling	6
1.3 Application	6
1.4 Warranty	6
1.5 Electrical Connection	6
1.6 Replacement Parts	7
1.7 Waste Disposal	7
1.8 Documentation	7
2 Agency	9
2.1 Product Standards and Approvals	9
2.2 ROHS 2 Compliance	9
3 Product Description	11
3.1 General	11
3.2 Vertiv™ Liebert® XDU450 Model Number Nomenclature	11
3.3 Product Views	13
4 Technical Data	17
4.1 General	17
4.2 Pipe Connections	18
4.3 Circuit Fluid Volumes	19
4.4 Electrical Data	20
4.5 Noise	20
5 Installation	21
5.1 Unloading and Positioning	21
5.2 Piping	23
5.2.1 Primary Facility Circuit Connections	23
5.2.2 Secondary Circuit Connections	25
5.3 Electrical	29
5.3.1 Power Wiring	29
5.3.2 Controls Wiring	31
5.3.3 Communications Wiring	31
5.3.4 Group Control	33
5.4 Pre-Commissioning Checks	34
5.4.1 Site Check	34
5.4.2 Mechanical Installation Check	34
5.4.3 Electrical Installation Check	35
5.4.4 Primary Liquid (Facility) Specification	37
5.4.5 Secondary Liquid Specification	39

- 6 Commissioning 41**
- 6.1 Primary Circuit 41
 - 6.1.1 Primary Pipework Installation 41
 - 6.1.2 Facility Water Supply 41
 - 6.1.3 Primary By-Pass Valve 41
 - 6.1.4 Primary Circuit Filling 42
 - 6.1.5 Primary Flow Setup 42
- 6.2 Secondary Circuit 42
 - 6.2.1 Secondary Pipework Connections 42
 - 6.2.2 Secondary Circuit Filling 43
- 6.3 Unit Configuration 44
- 6.4 Unit Low Speed Circulation 44
- 6.5 Overrides and Full Speed Operation 45
- 6.6 Pump Rotation 45
- 6.7 Full Manual Control 46
- 6.8 Subsequent Filling 46
- Appendices 49**
- Appendix A: Technical Support and Contacts 49
- Appendix B: Pipe Schematic Vertiv™ Liebert® XDU450 51
- Appendix C: Warranty Details 53
- Appendix D: Automatic Transfer Switch Installation and Commissioning 55
- Appendix E: Notes 65
- Appendix F: Disposal Information 67

1 Important Safety Information

Save These Instructions

This manual contains important instructions that should be followed during operation and maintenance of the Vertiv™ Liebert® XDU450.



WARNING! Arc flash and electric shock hazard. Can cause serious injury or death. Building and equipment damage may also result. Disconnect all local and remote electric power supplies and wear appropriate, OSHA-approved personal protective equipment (PPE) per NFPA 70E before working within the electric control enclosure. Customer must provide earth ground to unit, per NEC, CEC and local codes, as applicable.

Verify with a voltmeter that power is Off. The Vertiv™ Liebert® iCOM™ controller does not isolate power from the unit, even in the “Unit Off” mode. Some internal components still require and receive power even during the “Unit Off” mode of the Liebert® iCOM™ controller. The factory-supplied, optional disconnect switch is inside the unit. The line side of this switch contains live high voltage. The only way to ensure that there is NO voltage inside the unit is to install and open a remote disconnect switch. Refer to unit electrical schematic.

Before proceeding with installation, read all instructions, verify that all the parts are included and check the nameplate to be sure the voltage matches available utility power. Follow all local codes.



WARNING! Risk of electric shock. Can cause serious injury or death. Building and equipment damage may also result. Open all local and remote electric power supply disconnect switches and verify that power is off with a voltmeter before working within any electric connection enclosures. The Liebert® iCOM™ controller does not isolate power from the unit, even in the "Unit Off" mode. Some internal components require and receive power even during the "unit off" mode of the Liebert® iCOM™ controller.

Installation, service, and maintenance work must be performed only by properly trained and qualified personnel and in accordance with applicable regulations and manufacturers' specifications. Opening or removing the covers to any equipment may expose personnel to lethal voltages within the unit even when it is apparently not operating and the input wiring is disconnected from the electrical source.



WARNING! Risk of short circuits and electric shock. Can cause serious injury or death. Building and equipment damage can result from cut insulation or damaged wires. Can cause overheated wiring, smoke, fire, and activation of fire suppression systems and EMS personnel. Verify that all wiring connections are tight and that all wiring is contained within the junction box prior to closing and securing the cover.

Insert CSA-certified or UL-listed bushings into holes and/or knockouts used to route wiring through metal panels to protect the wire insulation from contact with sheet metal edges.



WARNING! Risk of improper wire sizing/rating and loose electrical connections causing overheated wire and electrical connection terminals resulting in smoke or fire. Can cause serious injury or death. Building and equipment damage may also result. Use correctly sized copper wire only and verify that all electrical connections are tight before turning power On. Check all electrical connections periodically and tighten as necessary.



WARNING! Risk of improper wiring, piping, moving, lifting and handling. Can cause serious injury or death. Building and equipment damage may also result. Installation and service of this equipment should be done only by qualified personnel who have been specially-trained in the installation of air-conditioning equipment and who are wearing appropriate, OSHA-approved PPE.



WARNING! Risk of improper moving. Can cause serious injury or death. Building and equipment damage may also result. Use only lifting equipment that is rated for the unit weight by an OSHA-certified rating organization. Shipping weights and unit weights are listed in the tables in [General on page 17](#) . Use the center of gravity indicators on the unit to determine the position of the slings.



WARNING! Risk of top-heavy unit falling over when improperly lifted or moved. Can cause serious injury or death. Building and equipment damage may also result. Read all of the following instructions and verify that all lifting and moving equipment is rated for the weight of the unit before attempting to move, lift, remove packaging from or prepare the unit for installation. Unit weights are specified in [General on page 17](#) .



WARNING! Risk of unsecured unit rolling off pallet. Can cause serious injury or death. Building and equipment damage may also result. The unit is on casters. Ensure that the unit and pallet are located on a flat surface before loosening the hardware securing the unit to its shipping pallet.



CAUTION: Risk of contact with extremely hot or cold surfaces. Can cause injury. Verify that all components have reached a temperature that is safe for human contact or wear appropriate, OSHA-approved PPE before working with the electric connection enclosures or unit cabinet. Perform maintenance only when the system is de-energized and component temperatures have become safe for human contact.



CAUTION: Risk of contact with sharp edges, splinters and exposed fasteners. Can cause injury. Only properly trained and qualified personnel wearing appropriate, OSHA-approved PPE should attempt to move, lift, remove packaging from or prepare the unit for installation.



CAUTION: Risk of improper handling heavy and lengthy parts. Can cause injury. Building and equipment damage may also result. Cabinet panels can exceed 5 ft. (1.5 m) in length and weigh more than 35 lb (15.9 kg). Follow relevant OSHA lifting recommendations and consider using a two-person lift for safe and comfortable removal and installation of cabinet panels. Only properly trained and qualified personnel wearing appropriate, OSHA-approved PPE should attempt to remove or install cabinet panels.



CAUTION: Risk of improper piping installation, leak checking, fluid chemistry and fluid maintenance. Can cause injury. Building and equipment damage may also result. Installation and service of this equipment should be done only by qualified personnel who have been specially-trained in the installation of air-conditioning equipment and who are wearing appropriate, OSHA-approved PPE.

NOTICE

Risk of improper power-supply connection. Can cause equipment damage and loss of warranty coverage.

Prior to connecting any equipment to a main or alternate power source (for example back-up generator systems) for start-up, commissioning, testing, or normal operation, ensure that these sources are correctly adjusted to the nameplate voltage and frequency of all equipment to be connected. In general, power-source voltages should be stabilized and regulated to within +/- 5% of the load nameplate nominal voltage. Also, ensure that no three-phase sources are single-phased at any time.

See transformer label for primary tap connections. Installer will need to change transformer primary taps if applied unit voltage is other than pre-wired tap voltage.

NOTICE

Risk of improper electrical connection of three-phase input power. Can cause backward pump rotation and unit damage. Service technicians should use a gauge set on the system during the initial start up to verify that the three-phase power is connected properly. Three-phase power must be connected to the unit line voltage terminals in the proper sequence so that the pump rotates in the proper direction. Incoming power must be properly phased to prevent pump from running backward. We recommend checking the unit's phasing with proper instrumentation to ensure that the power connections were made correctly. We also recommend verifying discharge and suction pressures during start up to ensure that the pumps are running in the correct direction.

NOTICE

Risk of piping-system corrosion and freezing fluids. Can cause leaks resulting in equipment and very expensive building damage. Heat exchangers and piping systems are at high risk of freezing and premature corrosion. Fluids in these systems must contain the proper antifreeze and inhibitors to prevent freezing and premature coil and piping corrosion. When the cooling unit or piping may be exposed to freezing temperatures, charge the system with coolant fluid based on the coldest ambient design temperature. Automotive antifreeze is unacceptable and must NOT be used in any fluid system. Use only coolant fluid solution that meets the requirements of recommended industry practices. Do not use galvanized pipe.

The system coolant fluid must be analyzed by a competent fluid-treatment specialist before start up to establish the inhibitor and antifreeze solution requirement and evaluated at regularly scheduled intervals throughout the life of the system to determine the pattern of inhibitor depletion.

The fluid complexity and variants of required treatment programs make it extremely important to obtain the advice of a competent and experienced fluid-treatment specialist and follow a regularly scheduled coolant-fluid system-maintenance program.

Fluid chemistry varies greatly as do the required additives, called inhibitors, that reduce the corrosive effect of the fluids on the piping systems and components.

The chemistry of the coolant fluid used must be considered, because some sources may contain corrosive elements that reduce the effectiveness of the inhibited formulation. Sediment deposits prevent the formation of a protective oxide layer on the inside of the coolant system components and piping. The coolant fluid must be treated and circulating through the system continuously to prevent the buildup of deposits and/or growth of sulfate reducing bacteria. Proper inhibitor maintenance must be performed to prevent corrosion of the system.

Consult fluid manufacturer for testing and maintenance of inhibitors.

Commercial-grade coolant fluid is generally less corrosive to the common metals of construction than water itself. It will, however, assume the corrosivity of the coolant fluid from which it is prepared and may become increasingly corrosive with use if not properly inhibited.

Vertiv recommends installing a monitored fluid-detection system that is wired to activate the automatic-closure of field-installed coolant-fluid supply and return shut-off valves to reduce the amount of coolant-fluid leakage and consequential equipment and building damage. The shut-off valves must be sized to close-off against the maximum coolant-fluid system pressure in case of a catastrophic fluid leak.

NOTICE

Risk of no-flow condition. Can cause equipment damage. Do not leave the water/coolant fluid-supply circuit in a no-flow condition. Idle fluid allows the collection of sediment that prevents the formation of a protective oxide layer on the inside of the tubes. Keep unit switched On and water/ coolant fluid-supply circuit system operating continuously.

NOTICE

Risk of leaking chilled water lines. Can cause equipment and building damage. Lines and joints must be inspected regularly. Improper installation, application and service practices can result in water leakage from the unit. Water leakage can result in severe property damage and loss of critical data center equipment. Do not locate unit directly above any equipment that could sustain water damage.

Vertiv recommends installing monitored leak detection equipment for the unit and supply and return lines.

NOTICE

Risk of a catastrophic water circuit rupture. Can cause expensive building and equipment damage.

Install an overflow drain pan under the unit with a monitored leak detection system in the pan and shutoff valves in the supply and return water lines that automatically close if water is detected by the leak detection system. The shutoff valves should be spring return and must be rated for a close-off pressure that is the same as or higher than the supply water pressure. If it is not possible to install an overflow drain pan, then a monitored leak detection system should be installed in the base of the unit or under the unit to actuate the shutoff valves immediately on a leak detection signal.

The overflow drain pan should have a drain line connected to it that flows to a floor drain or maintenance sink in case of a shutoff valve or leak detection system malfunction.

NOTICE

Risk of passageway interference. Can cause unit and/or structure damage. The unit may be too large to fit through a passageway while on or off the skid. Measure the unit and passageway dimensions, and refer to the installation plans prior to moving the unit to verify clearances.

NOTICE

Risk of damage from forklift. Can cause unit damage. Keep tines of the forklift level and at a height suitable to fit below the skid and/or unit to prevent exterior and/or underside damage.

NOTICE

Risk of improper storage. Can cause unit damage.

Keep the unit upright, indoors and protected from dampness, freezing temperatures and contact damage.

NOTICE

Risk of improper control circuits. Can cause equipment damage.

When using jumpers for troubleshooting, always remove jumpers when maintenance is complete. Jumpers left connected could override controls and cause equipment damage.

1.1 General

Mechanical and electrical equipment such as coolant distribution units present potential mechanical and electrical hazards. All safety, installation, operation and maintenance instructions must be adhered to. Any work on or use of the equipment must only be carried out by technically competent personnel who are fully trained. This product is designed to minimize all potential hazards by restricting access through unit casings, doors and covers while equipment is operational.

Before any maintenance work being carried out, ensure:

1. Equipment is switched OFF.
2. Equipment and controls are disconnected from the electrical supply.
3. All rotating parts such as pumps and 3-way valve have come to rest.

If in any doubt over anything regarding safety, installation, operation or maintenance instructions, it is essential that the manufacturer, their agent or appointed representative is consulted for clarification and advice.

1.2 Installation/Handling



WARNING! Risk of improper wiring, piping, moving, lifting and handling. Can cause serious injury or death. Building and equipment damage may also result. Installation and service of this equipment should be done only by qualified personnel who have been specially-trained in the installation of air-conditioning equipment and who are wearing appropriate, OSHA-approved PPE.

Installation and operation must be conducted in accordance with local and national regulations and normal codes of good practice. When moving or lifting the product, caution must be observed to ensure the safety of personnel. Only the appropriate lifting equipment must be used.

1.3 Application

This product is to be used indoors only and must only be used for the application it was designed for. This product must not be used in a hazardous environment.

1.4 Warranty

Failure to comply with the Vertiv installation, maintenance, and operation instructions may affect the reliability and performance of the unit and invalidate any warranty.

1.5 Electrical Connection



WARNING! Arc flash and electric shock hazard. Can cause serious injury or death. Building and equipment damage may also result. Disconnect all local and remote electric power supplies and wear appropriate, OSHA-approved personal protective equipment (PPE) per NFPA 70E before working within the electric control enclosure. Customer must provide earth ground to unit, per NEC, CEC and local codes, as applicable.

Verify with a voltmeter that power is Off. The Vertiv™ Liebert® iCOM™ controller does not isolate power from the unit, even in the “Unit Off” mode. Some internal components still require and receive power even during the “Unit Off” mode of the Liebert® iCOM™ controller. The factory-supplied, optional disconnect switch is inside the unit. The line side of this switch contains live high voltage. The only way to ensure that there is NO voltage inside the unit is to install and open a remote disconnect switch. Refer to unit electrical schematic.

Before proceeding with installation, read all instructions, verify that all the parts are included and check the nameplate to be sure the voltage matches available utility power. Follow all local codes.

Electrical connections should be carried out in accordance with local and national regulations by a qualified electrician. Never make any electrical connections inside, or to the unit unless the electricity supply has been switched OFF at the disconnect (isolator).

1.6 Replacement Parts

Any parts replaced during maintenance or servicing must be the same specification as those being replaced and should only be obtained from Vertiv.

The use of incorrect replacement parts may affect the operation or reliability of the unit and invalidate any warranty. Please contact your local Vertiv representative for Vertiv engineered parts, check <https://www.Vertiv.com/en-us/support/> or call 1-800-543-2778.

1.7 Waste Disposal

Any waste or single use materials must be disposed of in a responsible manner and in strict adherence to local and national environmental regulations. For details, consult local environmental agencies.

1.8 Documentation

Operation and maintenance documentation together with commissioning, maintenance or service records must remain with the unit always.

This page intentionally left blank

2 Agency

2.1 Product Standards and Approvals

Vertiv products installed and operated in compliance with this document, the operation and maintenance guide and installation and commissioning guide, conform to the Low Voltage directive 2014/35/EU, the EMC directive 2014/30/EU and the Pressure Equipment directive 2014/68/EU. As manufactured, Vertiv products are designed to comply with an IP21 rating. This product is cUL listed for the appropriate voltage models and certificates will be made available on request (cUL certificate pending).



2.2 ROHS 2 Compliance

Vertiv certifies that all products manufactured and supplied by Vertiv are fully RoHS compliant in accordance with EU RoHS Directives 2002/95/EC – 2011/65/EU and the Council of 8 June 2011 directives, unless specified otherwise.



This page intentionally left blank

3 Product Description

3.1 General

This document describes the physical and electrical characteristics of the Vertiv™ Liebert® XDU450 for installation and commissioning purposes.

The Liebert® XDU450 contains a Secondary closed loop circuit that provides a supply of cooling liquid to IT equipment, either through indirect cooling (e.g. rack mounted rear door heat exchangers), or direct cooling (e.g. cold plates at chip level).

The Secondary circuit is a low pressure sealed system with the heat removed from the high heat density areas of IT equipment rejected to an external cooled liquid source (Primary circuit) via a low pressure drop plate heat exchanger.

The Secondary circuit ensures that the cooling fluid in a data center environment can be kept to a minimum volume, is closely controlled for flow, pressure, and temperature (with condensation control) and can be accurately maintained for liquid quality (with filtration and additives).

The Primary cooling source can be a chilled water system (either dedicated or from building system), fluid cooler, cooling tower or dry air cooler, depending on the desired Secondary temperature and heat transfer duty (refer to the Application and Planning Guide for more information).

3.2 Vertiv™ Liebert® XDU450 Model Number Nomenclature

The Liebert® XDU450 can be configured for voltage option to suit any global location, Primary/Secondary filtration, Primary Top/Bottom connections and Secondary Top/Bottom connections, or Secondary Manifold ready (i.e. ready to accept an internal manifold and cabinet extension).

Table 3.1 below is an example of the Liebert® XDU450 model number, fully configured. **Table 3.2** below describes each digit of the model number.

Table 3.1 Liebert® XDU450 Model Number

Digit	1	2	3	4	5	6	7	8	9	10	11	12	13	14	15	16	17	18	19	20	21	22	23	24	25	
Model #	X	D	U	0	4	5	0	A	A	0	0	A	2	B	B	0	0	0	0	0	0	1	2	3	4	E

Table 3.2 Liebert® XDU450 Model Number Definitions

Digit	Description
Digit 1-7, Model	Liebert® XDU450
Digit 8, Revision	A
Digit 9, Voltage	A = 460V/3PH/60Hz C = 208V/3PH/60Hz
Digit 10, ATS	0 = None C = ATS 200/208V A = ATS 440/480V
Digit 11, Communication	0 = Standard (Modbus) 1 = Standard with BACnet Gateway

Table 3.2 Liebert® XDU450 Model Number Definitions (continued)

Digit	Description
Digit 12, Primary Filtration	0 = None 1 = Fitted (500 μ)
Digit 13, Secondary Filtration	0 = None (included 6 bar relief) 2 = Fitted (50 μ) (includes 3 bar relief)
Digit 14, Primary Connection	T = Top Connection B = Bottom Connection
Digit 15, Secondary Connection	T = Top Connection Kit B = Bottom Connection Kit M = Manifold Ready
Digit 16, Manifolding	0 = None P = 6-way header with 1" BSP(P) thread R = 6-way header with 1" BSP BV valve S = 6-way header with 1" BSP BV/DRV valve T = 8-way header with 1" BSP thread U = 8-way header with 1" BSP BV valve V = 6-way header with 1" NPT (P) thread W = 6-way header with 1" NPT BV valve X = 6-way header with 1" NPT/DRV valve Y = 8-way header with 1" NPT thread Z = 8-way header with 1" NPT 8V valve
Digit 17	Open
Digit 18	Open
Digit 19	Open
Digit 20	Open
Digit 21-24, Factory Configuration	-
Digit 25, Configuration Code Digit	A-Z = Standard Configuration (excluding S) S = Special Feature Authorization

3.3 Product Views

Figure 3.1 Front View of Vertiv™ Liebert® XDU450 (without panels)

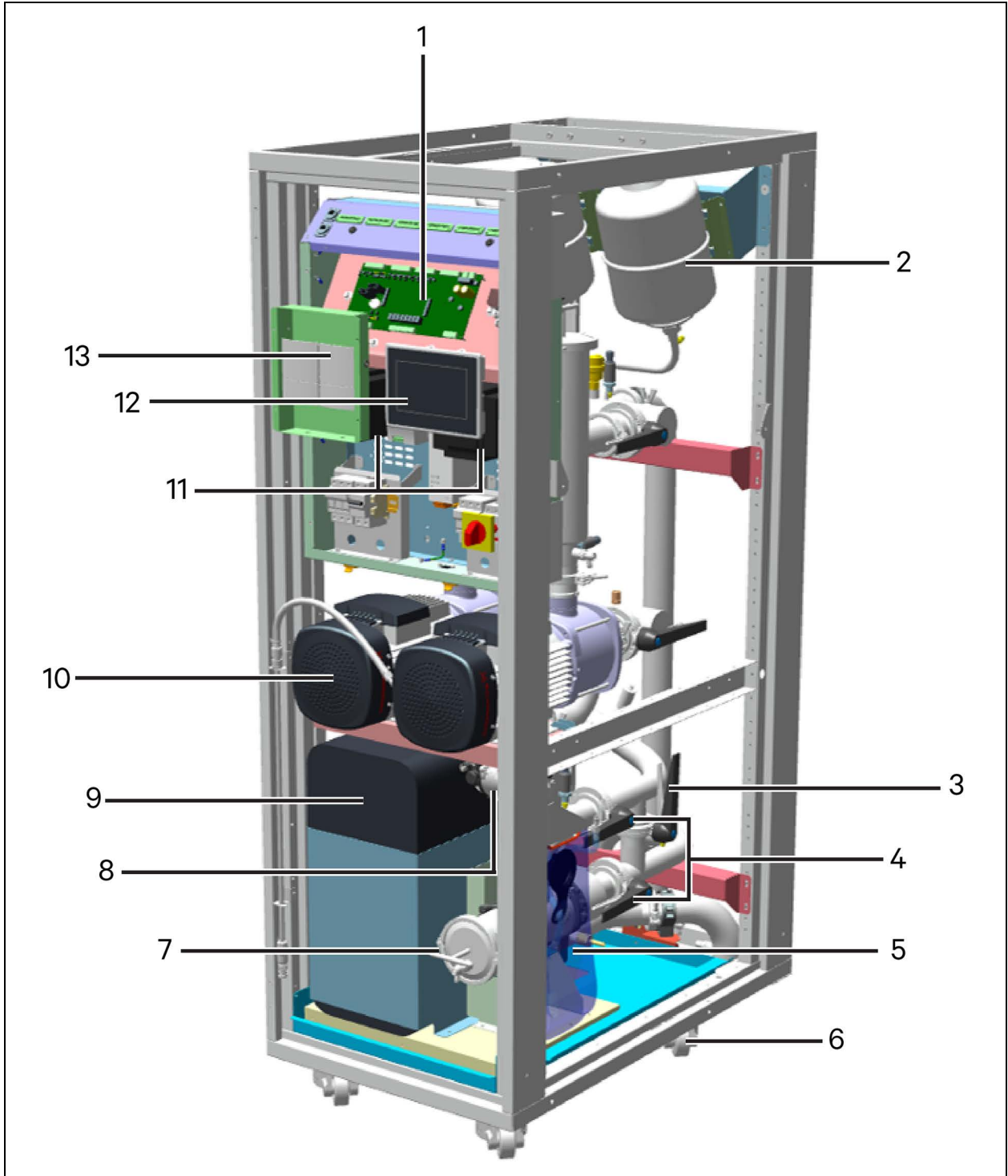

Item	Description
1	Controller/processor
2	Expansion vessels
3	Primary filter by-pass valve (if fitted)
4	Primary filter isolation valves (if fitted)
5	Water make-up container
6	Wheels and adjustable feet
7	Primary filter (optional)
8	Filling pump
9	Plate heat exchanger
10	Secondary pumps (dual pump unit shown)
11	Pump inverter drives
12	Controller touchscreen (mounted to front door)
13	Room temperature and RH sensors (mounted to front door)

Figure 3.2 Rear View of Vertiv™ Liebert® XDU450 (with bottom exit Primary and Secondary tails)

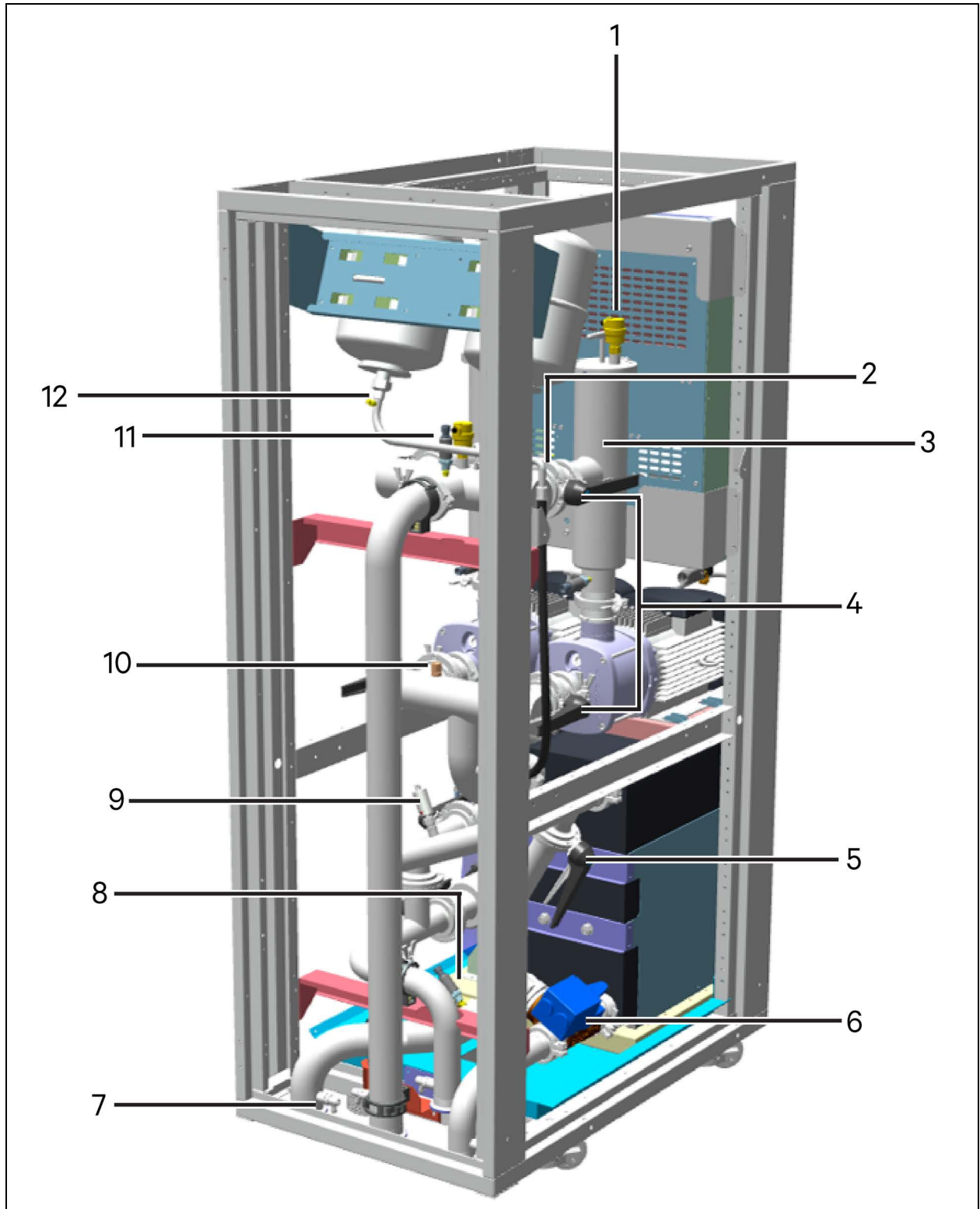

Item	Description
1	Auto air vent (fitted to each filter housing)
2	Pressure relief valve
3	Optional secondary filters
4	Filter/pump isolation valves
5	By-pass shut-off valve (closed to convert 3-way primary control valve to 2-way)
6	Primary cooling valve (3-way with manual override)
7	Drain valves
8	Secondary flow meter
9	Primary flow meter
10	Level sensors
11	Pressure sensors
12	Manual air vents (fitted beneath expansion vessels)

4 Technical Data

4.1 General

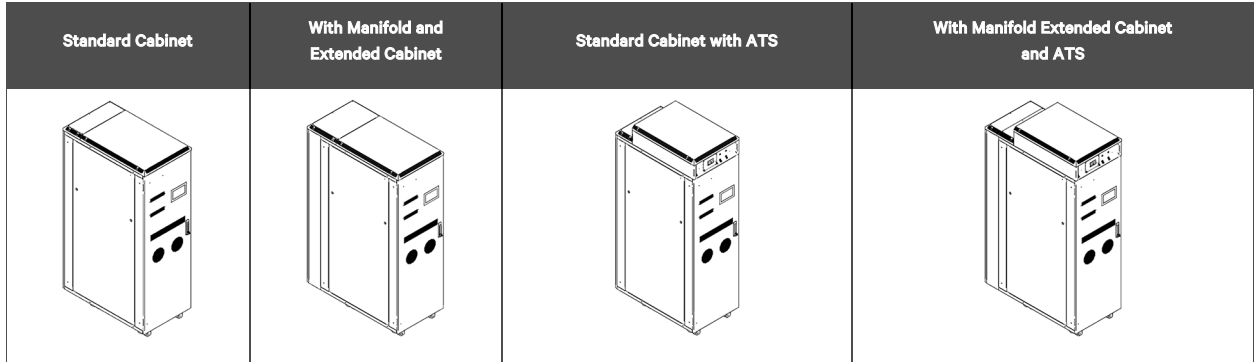

Table 4.1 Unit Dimensions

Base Unit	Width		Depth		Height	
	in.	mm	in.	mm	in.	mm
Standard cabinet	23.6	600	41	1042	74.8	1900
With manifold and extended cabinet	23.6	600	47	1194	74.8	1900
Standard cabinet with ATS	23.6	600	41	1042	81.1	2060
With manifold extended cabinet and ATS	23.6	600	47	1194	81.1	2060

Table 4.2 Shipping Dimensions - Domestic

Base Unit	Width		Depth		Height	
	in.	mm	in.	mm	in.	mm
Standard cabinet	29.5	1000	47.2	1150	82.7	2080
With manifold and extended cabinet	29.5	1000	57.1	1400	82.7	2080
Standard cabinet with ATS	29.5	1000	47.2	1150	89	2240
With manifold extended cabinet and ATS	29.5	1000	57.1	1400	89	2240

Table 4.3 Weight

Base Unit	Dry		Operating		Shipping Domestic	
	lbs.	kg	lbs.	kg	lbs.	kg
Standard cabinet	848	385	910	413	1143	518
With manifold and extended cabinet	890	397	938	425	1225	549
Standard cabinet with ATS	881	400	943	428	1196	543
With manifold extended cabinet and ATS	923	412	971	440	1258	564

4.2 Pipe Connections



CAUTION: Risk of improper piping installation, leak checking, fluid chemistry and fluid maintenance. Can cause injury. Building and equipment damage may also result. Installation and service of this equipment should be done only by qualified personnel who have been specially-trained in the installation of air conditioning equipment and who are wearing appropriate, OSHA-approved PPE.

NOTICE

Risk of piping-system corrosion and freezing fluids. Can cause leaks resulting in equipment and very expensive building damage. Heat exchangers and piping systems are at high risk of freezing and premature piping corrosion. Fluids in these systems must contain the proper antifreeze and inhibitors to prevent freezing and premature coil and piping corrosion. When the cooling unit or piping may be exposed to freezing temperatures, charge the system with coolant fluid based on the coldest ambient design temperature. Automotive antifreeze is unacceptable and must NOT be used in any fluid system. Use only coolant fluid solution that meets the requirements of recommended industry practices. Do not use galvanized pipe.

The system coolant fluid must be analyzed by a competent fluid-treatment specialist before start up to establish the inhibitor and antifreeze solution requirement and evaluated at regularly scheduled intervals throughout the life of the system to determine the pattern of inhibitor depletion.

The fluid complexity and variants of required treatment programs make it extremely important to obtain the advice of a competent and experienced fluid-treatment specialist and follow a regularly scheduled coolant-fluid system-maintenance program.

Fluid chemistry varies greatly as do the required additives, called inhibitors, that reduce the corrosive effect of the fluids on the piping systems and components.

The chemistry of the coolant fluid used must be considered, because some sources may contain corrosive elements that reduce the effectiveness of the inhibited formulation. Sediment deposits prevent the formation of a protective oxide layer on the inside of the coolant system components and piping. The coolant fluid must be treated and circulating through the system continuously to prevent the buildup of deposits and/or growth of sulfate reducing bacteria. Proper inhibitor maintenance must be performed to prevent corrosion of the system.

Consult fluid manufacturer for testing and maintenance of inhibitors.

Commercial-grade coolant fluid is generally less corrosive to the common metals of construction than water itself. It will, however, assume the corrosivity of the coolant fluid from which it is prepared and may become increasingly corrosive with use if not properly inhibited.

Vertiv recommends installing a monitored fluid-detection system that is wired to activate the automatic-closure of field-installed coolant-fluid supply and return shut-off valves to reduce the amount of coolant-fluid leakage and consequential equipment and building damage. The shut-off valves must be sized to close-off against the maximum coolant-fluid system pressure in case of a catastrophic fluid leak.

NOTICE

Risk of no-flow condition. Can cause equipment damage. Do not leave the water/coolant fluid-supply circuit in a no-flow condition. Idle fluid allows the collection of sediment that prevents the formation of a protective oxide layer on the inside of the tubes. Keep unit switched On and water/coolant fluid-supply circuit system operating continuously. In multiple unit teams, allow standby units to enter the rotation automatically or schedule regular manual rotations.

NOTICE

Risk of leaking chilled water lines. Can cause equipment and building damage.

Lines and joints must be inspected regularly. Improper installation, application and service practices can result in water leakage from the unit. Water leakage can result in severe property damage and loss of critical data center equipment. Do not locate unit directly above any equipment that could sustain water damage.

Vertiv recommends installing monitored leak detection equipment for the unit and supply and return lines.

NOTICE

Risk of a catastrophic water circuit rupture. Can cause expensive building and equipment damage.

Install an overflow drain pan under the unit with a monitored leak detection system in the pan and shutoff valves in the supply and return water lines that automatically close if water is detected by the leak detection system. The shutoff valves should be spring return and must be rated for a close-off pressure that is the same as or higher than the supply water pressure. If it is not possible to install an overflow drain pan, then a monitored leak detection system should be installed in the base of the unit or under the unit to actuate the shutoff valves immediately on a leak detection signal.

The overflow drain pan should have a drain line connected to it that flows to a floor drain or maintenance sink in case of a shutoff valve or leak detection system malfunction.

Pipe connections for both Primary and Secondary circuits are made at the rear of the cabinet and can be either top or bottom exit according to how the unit has been specified.

Table 4.4 Sanitary Flanges

Primary (facility) circuit:	2" (DN50) sanitary flanges, top or bottom exit
Secondary circuit:	2-1/2" (DN65) sanitary flanges, top or bottom exit or manifold system with up to 8 x 1" feeds – configurable according to customer requirements, top or bottom exit.

4.3 Circuit Fluid Volumes

Pipe connections for both Primary and Secondary circuits are made at the rear of the cabinet and can be either top or bottom exit according to how the unit has been specified.

Primary (facility) circuit:	5.86 gal. (22.2 L) basic
Options (additional volume added to basic volume):	1.08 gal. (4.1 L) for filter
	0.34 gal. (1.3 L) for bottom exit tails
	1.63 gal. (6.2 L) for top exit tails
Secondary circuit:	8.40 gal. (31.8 L)
Options (additional volume added to basic volume):	1.32 gal. (5.0 L) for filters
	1.45 gal. (5.5 L) for bottom exit tails
	2.13 gal. (8.1 L) for top exit tails
	1.95 gal. (7.4 L) for external manifolds

4.4 Electrical Data

Table 4.5 Supported Power Supplies

Voltage	FLA	WSA	OPD
208*	16.8 A	30 A	50 A
480**	15.0 A	30 A	40 A
Installed load	12.5 kVA (max.)		
Typical power	7.5 kW		
*Tolerance on three phase power is 208 V (+/- 5%), 60 Hz (+/- 3 Hz)			
**Tolerance on three phase power is 480 V (+/- 5%) 60 Hz (+/- 3 Hz)			

4.5 Noise

Sound power level at 3 m: <55 dBA

5 Installation

5.1 Unloading and Positioning



WARNING! Risk of improper wiring, piping, moving, lifting and handling. Can cause serious injury or death. Building and equipment damage may also result. Installation and service of this equipment should be done only by qualified personnel who have been specially-trained in the installation of air-conditioning equipment and who are wearing appropriate, OSHA-approved PPE.



WARNING! Risk of improper moving. Can cause serious injury or death. Building and equipment damage may also result. Use only lifting equipment that is rated for the unit weight by an OSHA-certified rating organization. Shipping weights and unit weights are listed in the tables in [General](#) on page 17 .



WARNING! Risk of top-heavy unit falling over when improperly lifted or moved. Can cause serious injury or death. Building and equipment damage may also result. Read all of the following instructions and verify that all lifting and moving equipment is rated for the weight of the unit before attempting to move, lift, remove packaging from or prepare the unit for installation. Unit weights are specified in [General](#) on page 17 .



WARNING! Risk of unsecured unit rolling off pallet. Can cause serious injury or death. Building and equipment damage may also result. The unit is on casters. Ensure that the unit and pallet are located on a flat surface before loosening the hardware securing the unit to its shipping pallet.



CAUTION: Risk of improper handling heavy and lengthy parts. Can cause injury. Building and equipment damage may also result. Cabinet panels can exceed 5 ft. (1.5 m) in length and weigh more than 35 lb (15.9 kg). Follow relevant OSHA lifting recommendations and consider using a two-person lift for safe and comfortable removal and installation of cabinet panels. Only properly trained and qualified personnel wearing appropriate, OSHA-approved PPE should attempt to remove or install cabinet panels.



CAUTION: Risk of contact with sharp edges, splinters and exposed fasteners. Can cause injury. Only properly trained and qualified personnel wearing appropriate, OSHA-approved PPE should attempt to move, lift, remove packaging from or prepare the unit for installation.

NOTICE

Risk of passageway interference. Can cause unit and/or structure damage. The unit may be too large to fit through a passageway while on or off the skid. Measure the unit and passageway dimensions, and refer to the installation plans prior to moving the unit to verify clearances.

NOTICE

Risk of damage from forklift. Can cause unit damage. Keep tines of the forklift level and at a height suitable to fit below the skid and/or unit to prevent exterior and/or underside damage.

NOTICE

Risk of improper storage can cause unit damage. Keep the unit upright, indoors and protected from dampness, freezing temperatures and contact damage.

On arrival at site, the Vertiv™ Liebert® XDU450 crate should be placed on a level solid surface to safely unload the unit from the crate.

Check crate for any signs of external transit damage (any serious damage must be reported to manufacturer and shipper immediately, prior to unpacking).

The crate has been designed with a hinge down front panel to allow the Liebert® XDU450 to be easily wheeled off the pallet to floor level. Two wooden support blocks are provided inside the crate, which should be removed and placed under the hinge down panel to provide necessary support prior to wheeling the Liebert® XDU450 out, along with an infill strip to fill in the gap between door and pallet. The top and sides of the crate may also be removed for improved access if required.

! **CAUTION: The Liebert® XDU450 is a heavy piece of equipment and at least two operatives will be required to carry out the unloading task safely.**

Figure 5.1 Unloading Liebert® XDU450 Unit from Crate

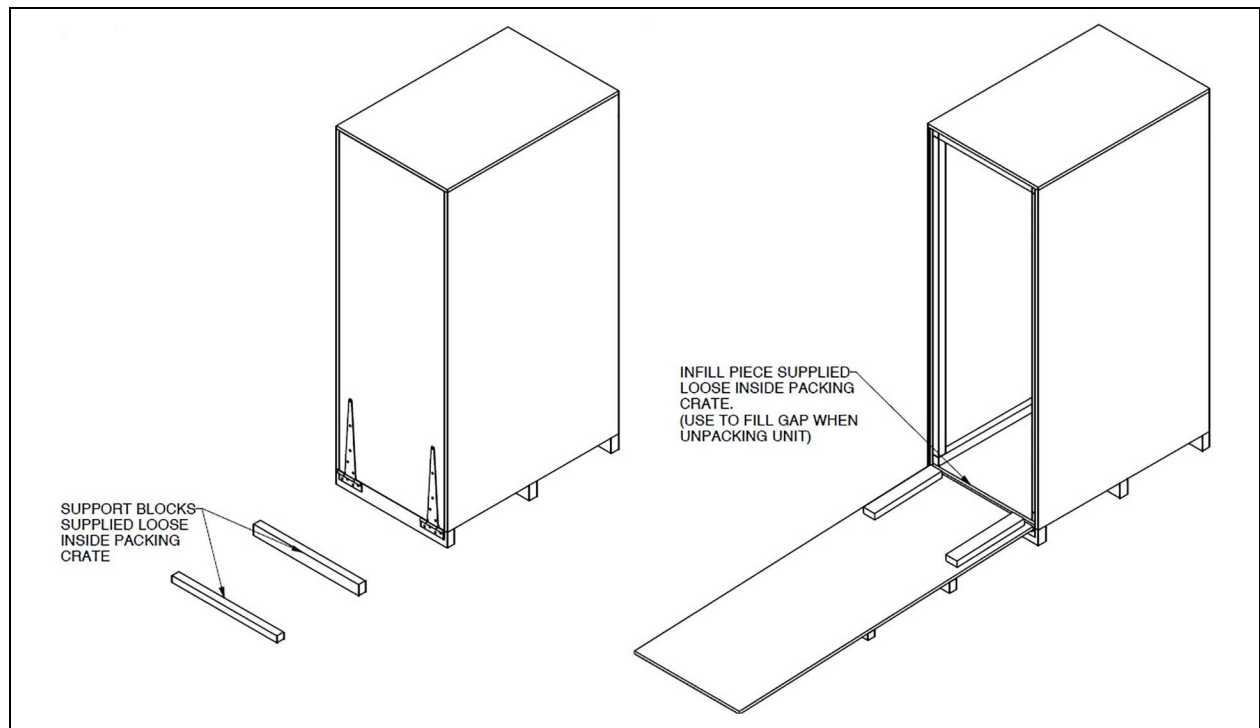

Once at floor level, the protective bubble wrap should be removed, and the unit inspected for any transit damage – any damage found must be reported to the manufacturer immediately and prior to installation.

The Liebert® XDU450 can be maneuvered into position on the supplied load bearing wheels and once in its final location, may be secured, raised and leveled using the in-built jacking feet. The keys for front and rear doors are supplied in a bag tied to the inside of the front door.

Space should be allowed at the front and rear of the unit in excess of 24 inches (600 mm) to allow the access doors to be fully opened.

5.2 Piping

The Vertiv™ Liebert® XDU450 is intended to be positioned on a smooth, level floor, ideally a raised floor (if bottom exit pipework) with at least 12 inches (300 mm) clear under floor space for a manifold system or hose runs to IT equipment. If the Liebert® XDU450 has bottom exit pipework, provision should be made to cut away the floor tiles as required to allow pipework to run to/from the XDU450 under the floor.

Overhead field piping should be fitted by the installer with high point air vents to remove air during filing and commissioning. These may be manual or automatic style vents. Automatic vents should not be placed in lines overhead of cabinets containing sensitive electronics or other electrical equipment.

External isolation valves should be fitted by the installer to both supply and return pipes, as close as possible to the Liebert® XDU450 for maintenance purposes and care should be taken that all inter-connecting pipework to/from the XDU450 is adequately supported, as the XDU450 is not designed for any external pipe loads. If the unit is to be installed in a seismic location, then suitable flexible joints should be fitted as determined by engineer of record.

5.2.1 Primary Facility Circuit Connections



CAUTION: Risk of improper piping installation, leak checking, fluid chemistry and fluid maintenance can cause equipment damage and personal injury. Installation and service of this equipment should be done only by qualified personnel who have been specially-trained in the installation of air-conditioning equipment and who are wearing appropriate, OSHA-approved PPE.

NOTICE

Risk of leaking chilled water lines. Can cause equipment and building damage.

Lines and joints must be inspected regularly. Improper installation, application and service practices can result in water leakage from the unit. Water leakage can result in severe property damage and loss of critical data center equipment. Do not locate unit directly above any equipment that could sustain water damage.

Vertiv recommends installing monitored leak detection equipment for the unit and supply and return lines.

NOTICE

Risk of a catastrophic water circuit rupture. Can cause expensive building and equipment damage.

Install an overflow drain pan under the unit with a monitored leak detection system in the pan and shutoff valves in the supply and return water lines that automatically close if water is detected by the leak detection system. The shutoff valves should be spring return and must be rated for a close-off pressure that is the same as or higher than the supply water pressure. If it is not possible to install an overflow drain pan, then a monitored leak detection system should be installed in the base of the unit or under the unit to actuate the shutoff valves immediately on a leak detection signal.

The overflow drain pan should have a drain line connected to it that flows to a floor drain or maintenance sink in case of a shutoff valve or leak detection system malfunction.

The primary facility chilled water is supplied by the end user. The Vertiv™ Liebert® XDU450 Primary connections are 2 inch (DN50) sanitary flanges (to BS4825 Pt.3 or equivalent with 64 mm diameter flange). The flanges are fitted with stainless steel blanking caps to ensure pipework remains contaminant free during transit, which will need to be removed for installation.

Optional 2 inch BSP or NPT threaded, or other types of adapters can be provided if specified at the time of order. The Vertiv™ Liebert® XDU450 Primary connections are located at the rear of the unit and can be configured for bottom or top exit from the cabinet as illustrated, which should be specified at time of order.

Figure 5.2 Primary Facility Circuit Connections

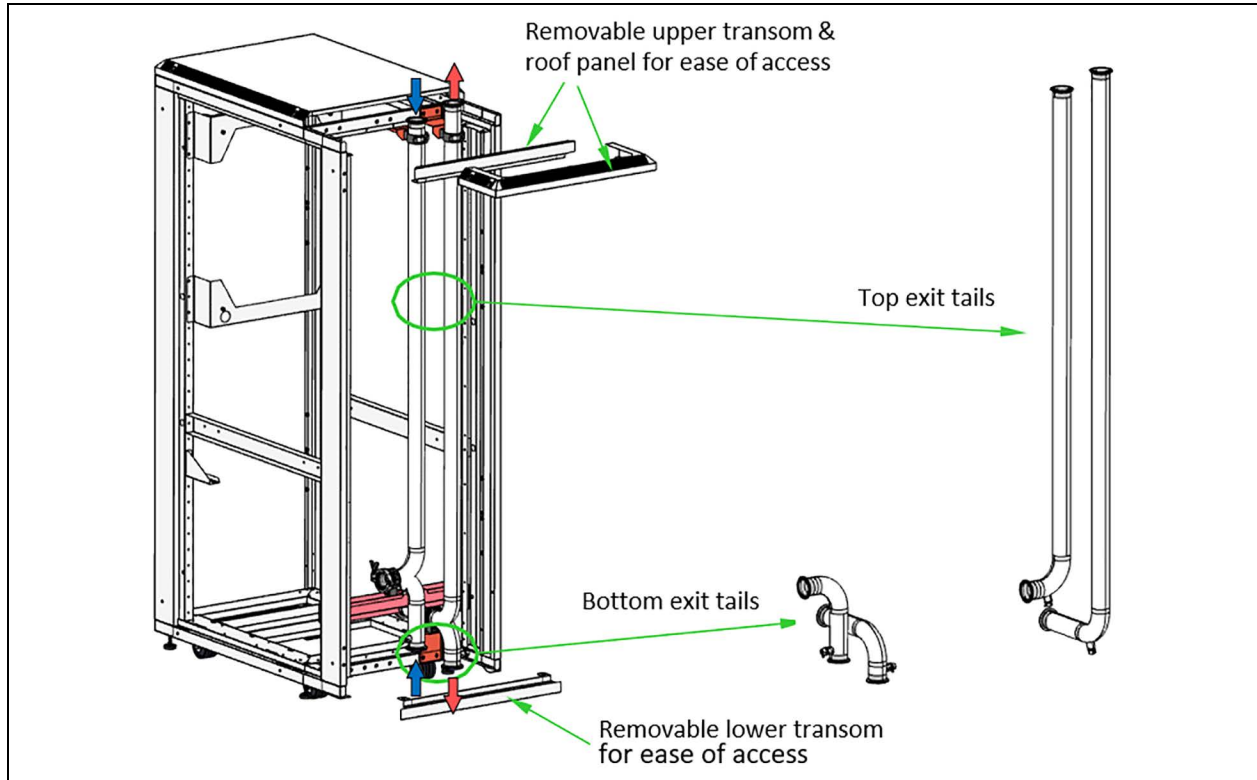

External isolation valves should be fitted by the installer to both supply and return pipes, as close as possible to the Liebert® XDU450 for maintenance purposes and care should be taken that all inter-connecting pipework to/from the XDU450 is adequately supported, as the XDU450 is not designed for any external pipe loads. If the unit is to be installed in a seismic location, then suitable flexible connections should be fitted as determined by engineer of record.

All primary circuit pipework and components should be insulated to protect against condensation.

5.2.2 Secondary Circuit Connections



CAUTION: Risk of improper piping installation, leak checking, fluid chemistry and fluid maintenance can cause equipment damage and personal injury. Installation and service of this equipment should be done only by qualified personnel who have been specially-trained in the installation of air-conditioning equipment and who are wearing appropriate, OSHA-approved PPE.

NOTICE

Risk of leaking chilled water lines. Can cause equipment and building damage.

Lines and joints must be inspected regularly. Improper installation, application and service practices can result in water leakage from the unit. Water leakage can result in severe property damage and loss of critical data center equipment. Do not locate unit directly above any equipment that could sustain water damage.

Vertiv recommends installing monitored leak detection equipment for the unit and supply and return lines.

NOTICE

Risk of a catastrophic water circuit rupture. Can cause expensive building and equipment damage.

Install an overflow drain pan under the unit with a monitored leak detection system in the pan and shutoff valves in the supply and return water lines that automatically close if water is detected by the leak detection system. The shutoff valves should be spring return and must be rated for a close-off pressure that is the same as or higher than the supply water pressure. If it is not possible to install an overflow drain pan, then a monitored leak detection system should be installed in the base of the unit or under the unit to actuate the shutoff valves immediately on a leak detection signal.

The overflow drain pan should have a drain line connected to it that flows to a floor drain or maintenance sink in case of a shutoff valve or leak detection system malfunction.

NOTE: Install manual shut-off valves at the primary and secondary lines to each unit to permit routine service and emergency isolation of the unit.

The Vertiv™ Liebert® XDU450 Secondary connections are 2.5 inch (DN65) sanitary flanges (to BS4825 Pt.3 or equivalent with 3 inch (77.5 mm) diameter flange). The flanges are fitted with stainless steel blanking caps to ensure pipework remains contaminant free during transit, which will need to be removed for installation. Optional other types of adapters can be provided if specified at the time of order.

The Liebert® XDU450 Secondary connections are located at the rear of the unit and can be configured for bottom or top exit from the cabinet as illustrated, which should be specified at time of order. Alternatively, an external manifold (up to eight-ways) can be fitted, housed in a 8.8 inch (225 mm) deep cabinet extension.

External isolation valves should be fitted by the installer to both supply and return pipes, as close as possible to the Liebert® XDU450 for maintenance purposes and care should be taken that all inter-connecting pipework to/from the XDU450 is adequately supported, as the XDU450 is not designed for any external pipe loads. If the unit is to be installed in a seismic location, then suitable flexible joints should be fitted as determined by engineer of record.

Figure 5.3 Secondary Circuit Connections

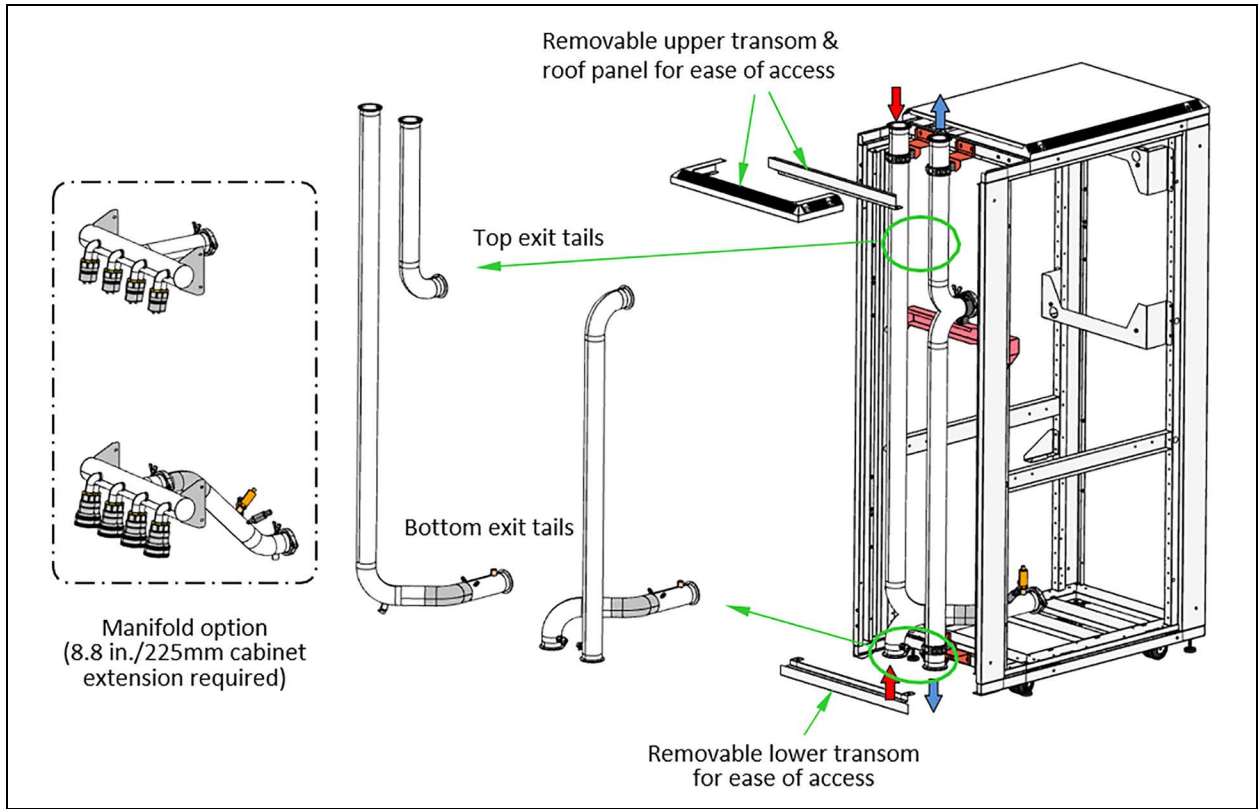
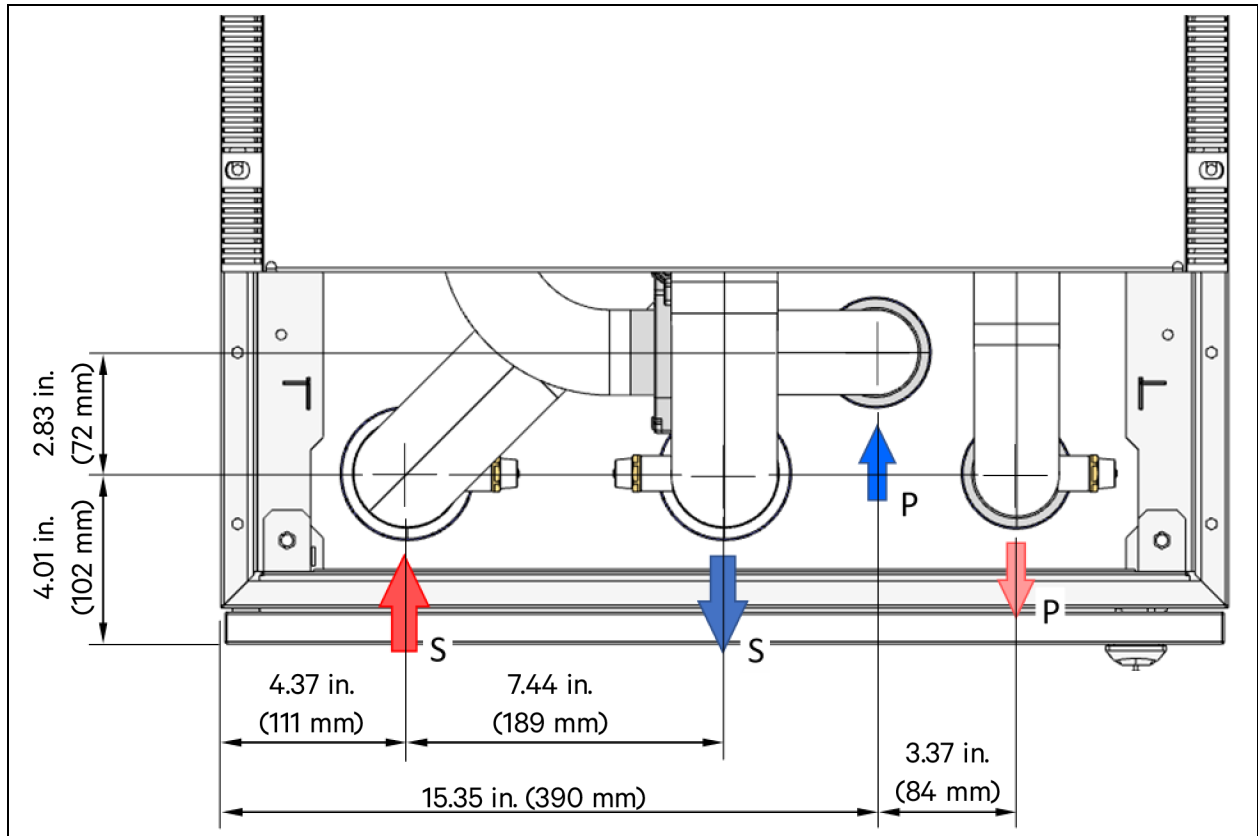

Figure 5.4 Rear Section Showing Primary Facility and Secondary Pipe Connection Locations



Plan view of Vertiv™ Liebert® XDU450 rear section showing Primary Facility and Secondary circuit pipe connection locations. Positions will be the same for both Bottom and Top Exit pipework.

- S = Secondary Circuit
- P = Primary Facility Circuit Connections

Figure 5.5 Internal Piping Detail

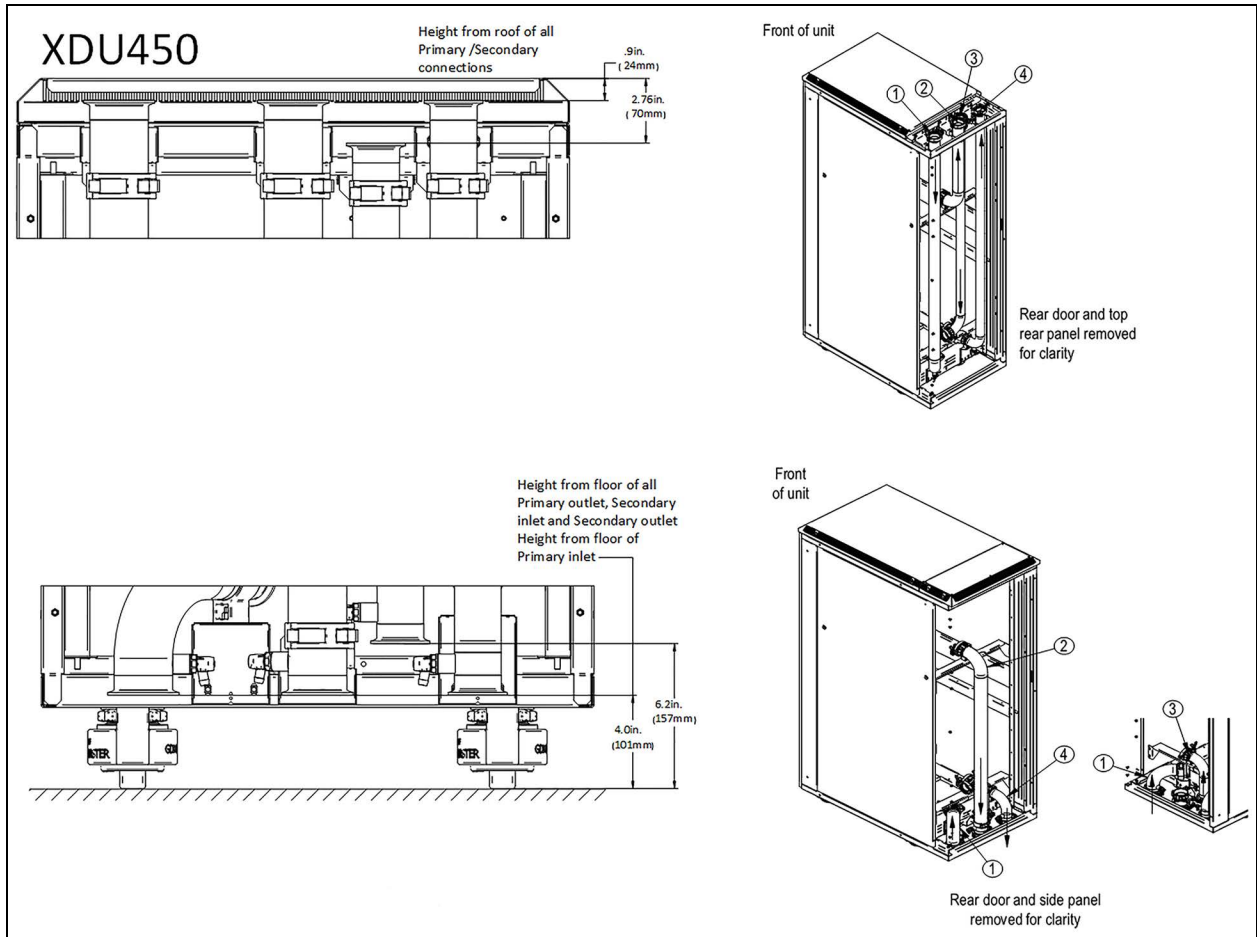

Item	Description	Size
1	Second circuit return from heat load	2.5 inch (DN65) sanitary flanges
2	Secondary circuit supply to heat load	2.5 inch (DN65) sanitary flanges
3	Facility supply fluid to CDU	2 inch (DN50) sanitary flanges
4	Facility return fluid to heat rejection	2 inch (DN50) sanitary flanges

5.3 Electrical

5.3.1 Power Wiring



WARNING! Arc flash and electric shock hazard. Can cause serious injury or death. Building and equipment damage may also result. Disconnect all local and remote electric power supplies and wear appropriate, OSHA-approved personal protective equipment (PPE) per NFPA 70E before working within the electric control enclosure. Customer must provide earth ground to unit, per NEC, CEC and local codes, as applicable.

Verify with a voltmeter that power is Off. Vertiv™ Liebert® iCOM™ controller does not isolate power from the unit, even in the “Unit Off” mode. Some internal components still require and receive power even during the “Unit Off” mode of the Liebert® iCOM™ controller. The factory-supplied, optional disconnect switch is inside the unit. The line side of this switch contains live high voltage. The only way to ensure that there is NO voltage inside the unit is to install and open a remote disconnect switch. Refer to unit electrical schematic.

Before proceeding with installation, read all instructions, verify that all the parts are included and check the nameplate to be sure the voltage matches available utility power. Follow all local codes.



WARNING! Risk of electric shock. Can cause serious injury or death. Building and equipment damage may also result. Open all local and remote electric power supply disconnect switches and verify that power is off with a voltmeter before working within any electric connection enclosures. The Liebert® iCOM™ controller does not isolate power from the unit, even in the "Unit Off" mode. Some internal components require and receive power even during the "unit off" mode of the Liebert® iCOM™ controller.

Installation, service, and maintenance work must be performed only by properly trained and qualified personnel and in accordance with applicable regulations and manufacturers' specifications. Opening or removing the covers to any equipment may expose personnel to lethal voltages within the unit even when it is apparently not operating and the input wiring is disconnected from the electrical source.



WARNING! Risk of short circuits and electric shock. Can cause serious injury or death. Building and equipment damage can result from cut insulation or damaged wires. Can cause overheated wiring, smoke, fire, activation of fire suppression systems and EMS personnel, and loss of power to fans. Verify that all wiring connections are tight and that all wiring is contained within the junction box prior to closing and securing the cover.

Insert CSA-certified or UL-listed bushings into holes and/or knockouts used to route wiring through metal panels to protect the wire insulation from contact with sheet metal edges.



WARNING! Risk of improper wire sizing/rating and loose electrical connections causing overheated wire and electrical connection terminals resulting in smoke or fire. Can cause serious injury or death. Building and equipment damage may also result. Use correctly sized copper wire only and verify that all electrical connections are tight before turning power On. Check all electrical connections periodically and tighten as necessary.



WARNING! Risk of improper wiring, piping, moving, lifting and handling. Can cause serious injury or death. Building and equipment damage may also result. Installation and service of this equipment should be done only by qualified personnel who have been specially-trained in the installation of air-conditioning equipment and who are wearing appropriate, OSHA-approved PPE.

NOTICE

Risk of improper power-supply connection. Can cause equipment damage and loss of warranty coverage.

Prior to connecting any equipment to a main or alternate power source (for example back-up generator systems) for start-up, commissioning, testing, or normal operation, ensure that these sources are correctly adjusted to the nameplate voltage and frequency of all equipment to be connected. In general, power-source voltages should be stabilized and regulated to within +/- 5% of the load nameplate nominal voltage. Also, ensure that no three-phase sources are single-phased at any time.

See transformer label for primary tap connections. Installer will need to change transformer primary taps if applied unit voltage is other than pre-wired tap voltage.

NOTICE

Risk of improper electrical connection of three-phase input power. Can cause backward pump rotation and unit damage. Service technicians should use a gauge set on the system during the initial start up to verify that the three-phase power is connected properly. Three-phase power must be connected to the unit line voltage terminals in the proper sequence so that the pump rotates in the proper direction. Incoming power must be properly phased to prevent pump from running backward. We recommend checking the unit's phasing with proper instrumentation to ensure that the power connections were made correctly. We also recommend verifying discharge and suction pressures during start up to ensure that the pumps are running in the correct direction.

The incoming power cable can be routed into the unit via the floor void or through the cabinet roof panel.

The electrical panel is divided into two compartments - the upper section is dedicated to extra-low voltage for controls, while the lower section is for mains power and has a door interlocked disconnect/isolator to remove power prior to opening. Both sections require an 0.31 inch (8 mm) triangular key to open (unit is provided with cabinet keys).

A 1 inch (25 mm) cable gland is provided on the back face of the electrical panel, at the lower right-hand corner, to accept a 0.35 inch - 0.63 inch (9 -16 mm) diameter power cable. The cable termination point is at the main electrical panel disconnect (isolator) and adjacent ground (earth) terminal. Upstream protection must be provided by the end user in the form of fuses or breakers in accordance with the maximum loads stipulated on the wiring diagram and in accordance to local regulations.

RF Earth Connection – For EMC compliance, two M6 earth studs are provided at the rear of the cabinet (one at the top and one at the bottom) for connection of a braided EMC earth strap at either point.

The Vertiv™ Liebert® XDU450 units are supplied configured for the required voltage option stated in [Electrical Data](#) on page 20 . This will have been specified at the time of order. Check data plate information for compatibility prior to installation.

The Liebert® XDU450 can accept A and B power supplies when provided with the optional factory installed ATS (Automatic Transfer Switch). The ATS may also be added as a field installed option. See [Automatic Transfer Switch Installation and Commissioning](#) on page 55 for installation, connection, and commissioning of the ATS option.

5.3.2 Controls Wiring

NOTICE

Risk of improper control circuits. Can cause equipment damage. When using jumpers for troubleshooting, always remove jumpers when maintenance is complete. Jumpers left connected could override controls and cause equipment damage.

If required terminal 1 and 2 of connector SK8 on top of the electrical panel (see **Figure 5.6** below) can be wired to a remote volt free start/stop signal. Breaking this circuit will stop the unit and re-making will allow the unit to automatically re-start - this can be configured as normally open or normally closed (default) if required. Terminals 5 and 6 and 7 and 8 on SK8 are volt free contacts for remote indication of warnings and alarms – configurable as normally open (default) or normally closed.

A single room temperature and RH sensor is provided as standard on the Vertiv™ Liebert® XDU450, fitted to the cabinet front door panel behind a ventilation grille to monitor the room temperature and humidity. The temperature and humidity sensor must be installed in areas where conditions are representative of the space conditioned by the Liebert® XDU . Vertiv recommends installing the sensor in different areas near the heat load by the Liebert® XDU. The temperature and humidity sensor may be mounted remotely up to 200 feet using field supplied Beldon 3106A, or equivalent cable. Do not install the sensors where ambient air might cause false readings, for example, near unsealed doors or windows, or areas with stagnant air.

A Leak detection tape (optional) can be connected to terminals 5 and 6 on SK7 for leak detection under the floor.

5.3.3 Communications Wiring

Several alternative communications options are provided on the Vertiv™ Liebert® XDU450:

1. RS485 Modbus (terminals 1, 2 and 3 on connector SK3) – use Beldon 3106 A, or equivalent (1 pair +1, shielded 22 AWG).
2. CANbus (terminals 4, 5 and 6 on connector SK3) – use Beldon 3106 A, or equivalent (1 pair +1, shielded 22 AWG). CANbus is used for communication between Liebert® XDU450s for “Group Control”.
3. Two Ethernet ports (RJ45) - Cat5e shielded cable.

Figure 5.6 Communication Options and Locations

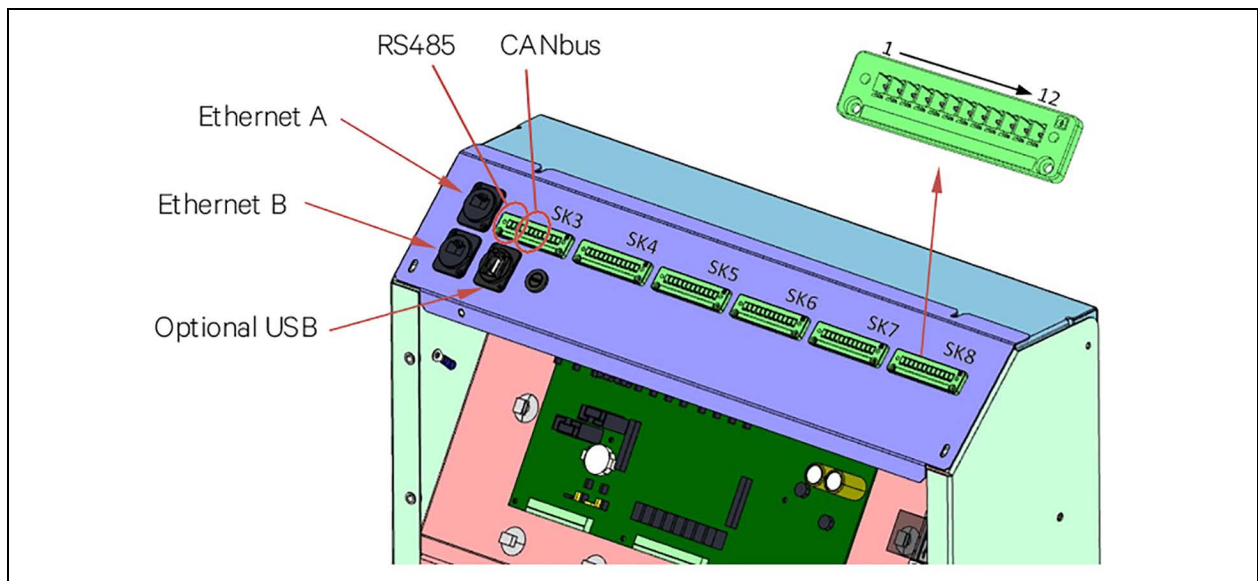

Optional BACnet communications is also available if specified.

BACnet IP– Ethernet 10/100

- Ethernet RJ45 connection on unit mounted BACnet gateway
- Cable provided by others for connection to the BMS. No special considerations are required when using Cat5e/Cat6 for connection between the unit and BMS which is not greater than 328ft (100m).

BACnet MSTP– RS485

- Terminals B1, 2 & 3 on unit mounted BACnet gateway
- Cable provided by others for connection to the BMS. No special considerations are required when using Cat5e/Cat6 for connection between the unit and BMS which is not greater than 4000ft (1220m).
- Use Beldon 89207 (plenum rated), or Alpha Wire 6454 or equivalent (1 pair +1, shielded 22AWG).

Figure 5.7 BACnet Wiring

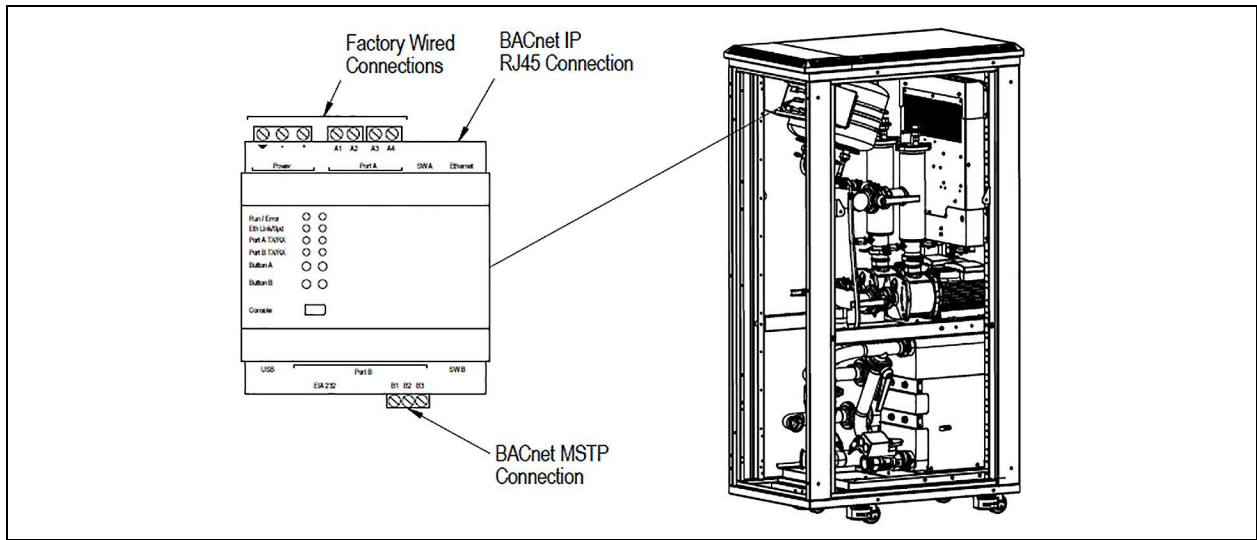

NOTE: Some Building Management Systems can be configured to send continuous updates for device setpoints, usually setting the same value. The BMS should be configured to send, on a sustained average, no more than two writes per second to the device. This will allow the device to catch up after a burst of updates when required while allowing other communication with the device to proceed.

5.3.4 Group Control

Figure 5.8 Vertiv™ Liebert® XDU450 Group Control (max number of units in a single group is 8)

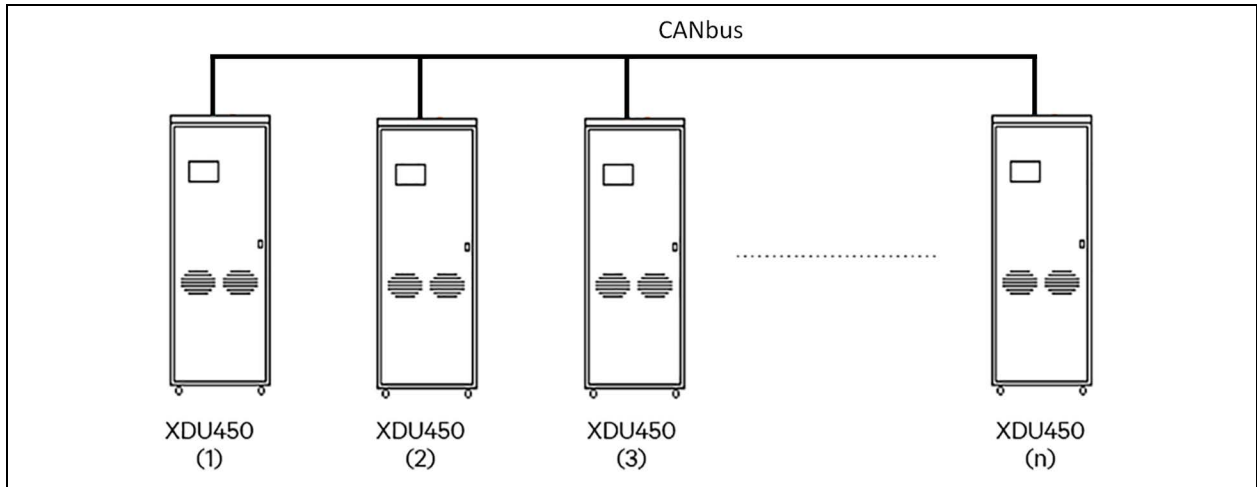

For larger and N+x redundancy installations, Liebert® XDU450s can be connected using CANbus high speed, robust twisted pair.

The units become self-organizing, the master unit is automatically selected which coordinates the running state of each unit in group based on:

- Configured level of redundancy
- System pressure requirements
- Alarm conditions

Changes to settings are automatically synced across the network.

Figure 5.9 Vertiv™ Liebert® XDU450 Group Control Status Screen

Group Control Status							
CDU	Mode	DP bar	Flow Rate l/m	Pump Speed %	Temp T2 °C	Cooling Demand %	Lead
1	Online (Running)	1.89	230	55	18.2	67	1
2	Online (Running)	1.92	235	55	18.1	73	0
3	Online (Running)	1.97	210	55	18.0	59	0
4	Group Standby	1.76	0	0	18.8	0	0
5	Shutdown	1.23	0	0	19.2	0	0
6	Not In Group	0	0	0	0	0	0
7	Not In Group	0	0	0	0	0	0
8	Not In Group	0	0	0	0	0	0

Average System DP	1.91 bar	Total System Flow Rate	670 l/m
-------------------	----------	------------------------	---------



5.4 Pre-Commissioning Checks

5.4.1 Site Check

1. Check if the site requires protective equipment such as safety boots, etc.
2. Check that the coolant has been delivered to site.
3. Check any required biocide and corrosion inhibitors have been supplied.
4. Ensure that site contact is aware of the location of Vertiv™ Liebert® XDU450 power supply fuse board/circuit breakers.
5. Ensure that site contact is aware of the location of the chiller/building services cold water supply and associated isolation valves.

5.4.2 Mechanical Installation Check

1. Confirm that Vertiv™ Liebert® XDU450 has been successfully unloaded from its crate and thoroughly inspected for damage, paying particular attention to external cabinet panels and water circuit pipework.
2. Liebert® XDU450 has been positioned and secured in correct location.
3. If the unit has bottom exit pipework, or manifold and hoses - confirm that floor tiles have been cut away as required, ideally fitted with brush strip grommets to allow hoses or pipes to run neatly into the under-floor void.
4. Check cable baskets/cable trays/drip trays, etc have been installed to provide adequate support for the hoses or manifold.
5. Confirm 24 inches of clearance is available in front and rear of the unit to fully open the access doors.
6. Ensure the unit has been raised and leveled with the jacking feet into its final permanent position.

5.4.3 Electrical Installation Check



WARNING! Arc flash and electric shock hazard. Can cause serious injury or death. Building and equipment damage may also result. Disconnect all local and remote electric power supplies and wear appropriate, OSHA-approved personal protective equipment (PPE) per NFPA 70E before working within the electric control enclosure. Customer must provide earth ground to unit, per NEC, CEC and local codes, as applicable.

Verify with a voltmeter that power is Off. Vertiv™ Liebert® iCOM™ controller does not isolate power from the unit, even in the “Unit Off” mode. Some internal components still require and receive power even during the “Unit Off” mode of the Liebert® iCOM™ controller. The factory-supplied, optional disconnect switch is inside the unit. The line side of this switch contains live high voltage. The only way to ensure that there is NO voltage inside the unit is to install and open a remote disconnect switch. Refer to unit electrical schematic.

Before proceeding with installation, read all instructions, verify that all the parts are included and check the nameplate to be sure the voltage matches available utility power. Follow all local codes.



WARNING! Risk of electric shock. Can cause serious injury or death. Building and equipment damage may also result. Open all local and remote electric power supply disconnect switches and verify that power is off with a voltmeter before working within any electric connection enclosures. The Liebert® iCOM™ controller does not isolate power from the unit, even in the "Unit Off" mode. Some internal components require and receive power even during the "unit off" mode of the Liebert® iCOM™ controller.

Installation, service, and maintenance work must be performed only by properly trained and qualified personnel and in accordance with applicable regulations and manufacturers' specifications. Opening or removing the covers to any equipment may expose personnel to lethal voltages within the unit even when it is apparently not operating and the input wiring is disconnected from the electrical source.



WARNING! Risk of short circuits and electric shock. Can cause serious injury or death. Building and equipment damage can result from cut insulation or damaged wires. Can cause overheated wiring, smoke, fire, activation of fire suppression systems and EMS personnel, and loss of power to fans. Verify that all wiring connections are tight and that all wiring is contained within the junction box prior to closing and securing the cover.

Insert CSA-certified or UL-listed bushings into holes and/or knockouts used to route wiring through metal panels to protect the wire insulation from contact with sheet metal edges.



WARNING! Risk of improper wire sizing/rating and loose electrical connections causing overheated wire and electrical connection terminals resulting in smoke or fire. Can cause serious injury or death. Building and equipment damage may also result. Use correctly sized copper wire only and verify that all electrical connections are tight before turning power On. Check all electrical connections periodically and tighten as necessary.



WARNING! Risk of improper wiring, piping, moving, lifting and handling. Can cause serious injury or death. Building and equipment damage may also result. Installation and service of this equipment should be done only by qualified personnel who have been specially-trained in the installation of air-conditioning equipment and who are wearing appropriate, OSHA-approved PPE.

NOTICE

Risk of improper power-supply connection. Can cause equipment damage and loss of warranty coverage.

Prior to connecting any equipment to a main or alternate power source (for example back-up generator systems) for start-up, commissioning, testing, or normal operation, ensure that these sources are correctly adjusted to the nameplate voltage and frequency of all equipment to be connected. In general, power-source voltages should be stabilized and regulated to within +/- 5% of the load nameplate nominal voltage. Also, ensure that no three-phase sources are single-phased at any time.

See transformer label for primary tap connections. Installer will need to change transformer primary taps if applied unit voltage is other than pre-wired tap voltage.

NOTICE

Risk of improper electrical connection of three-phase input power. Can cause backward pump rotation and unit damage. Service technicians should use a gauge set on the system during the initial start up to verify that the three-phase power is connected properly. Three-phase power must be connected to the unit line voltage terminals in the proper sequence so that the pump rotates in the proper direction. Incoming power must be properly phased to prevent pump from running backward. We recommend checking the unit's phasing with proper instrumentation to ensure that the power connections were made correctly. We also recommend verifying discharge and suction pressures during start up to ensure that the pumps are running in the correct direction.

1. Confirm installed Vertiv™ Liebert® XDU450 model is suitable for site supply voltage.
2. Power wiring connections completed between the remote and unit mounted disconnect switch.
3. Verify that the rating of the circuit breaker/fuses supplying the Liebert® XDU450 meets specification and rating as dictated by the latest wiring diagram.
4. If rating differs from Liebert® XDU450 specification, please note spec and confirm acceptability.
5. Check and record the voltage available across each of the three phases meets Liebert® XDU450 model requirements.
6. All internal and external high- and low-voltage wiring connections are tight.
7. Confirm that the Liebert® XDU450 is properly grounded to an earth ground and electrical service conforms to national and local codes.
8. If Liebert® XDU450 is in a different location to the IT racks, confirm the room Temp/RH sensor(s) have been installed on a wall adjacent to the data racks at a height of approximately 72 inches (1.8 m) using the correct extension cable.
9. Confirm any required external peripheral alarms/sensors are correctly fitted.

NOTE: The Liebert® XDU450 unit is shipped without the Class C fuses fitted upstream of the inverter drives (FS4 to FS9). These are shipped separately and will need to be fitted during installation of the unit.

NOTE: Due to international restrictions in the transport of cell batteries by air, the controller PCB may not have a battery fitted and a suitable battery will need to be sourced and fitted locally (type CR2032). The sole purpose of this battery is to maintain the real time clock in the event of power down and its absence will not generally affect the overall operation and running of the unit.

Although the touchscreen display also has a receptacle for a battery, there is no requirement to fit one to this PCB.

5.4.4 Primary Liquid (Facility) Specification

NOTICE

Risk of piping-system corrosion and freezing fluids. Can cause leaks resulting in equipment and very expensive building damage. Heat exchangers and piping systems are at high risk of freezing and premature corrosion. Fluids in these systems must contain the proper antifreeze and inhibitors to prevent freezing and premature coil and piping corrosion. When the cooling unit or piping may be exposed to freezing temperatures, charge the system with coolant fluid based on the coldest ambient design temperature. Automotive antifreeze is unacceptable and must NOT be used in any fluid system. Use only coolant fluid solution that meets the requirements of recommended industry practices. Do not use galvanized pipe.

The system coolant fluid must be analyzed by a competent fluid-treatment specialist before start up to establish the inhibitor and antifreeze solution requirement and evaluated at regularly scheduled intervals throughout the life of the system to determine the pattern of inhibitor depletion.

The fluid complexity and variants of required treatment programs make it extremely important to obtain the advice of a competent and experienced fluid-treatment specialist and follow a regularly scheduled coolant-fluid system-maintenance program.

Fluid chemistry varies greatly as do the required additives, called inhibitors, that reduce the corrosive effect of the fluids on the piping systems and components.

The chemistry of the coolant fluid used must be considered, because some sources may contain corrosive elements that reduce the effectiveness of the inhibited formulation. Sediment deposits prevent the formation of a protective oxide layer on the inside of the coolant system components and piping. The coolant fluid must be treated and circulating through the system continuously to prevent the buildup of deposits and/or growth of sulfate reducing bacteria. Proper inhibitor maintenance must be performed to prevent corrosion of the system.

Consult fluid manufacturer for testing and maintenance of inhibitors.

Commercial-grade coolant fluid is generally less corrosive to the common metals of construction than water itself. It will, however, assume the corrosivity of the coolant fluid from which it is prepared and may become increasingly corrosive with use if not properly inhibited.

Vertiv recommends installing a monitored fluid-detection system that is wired to activate the automatic-closure of field-installed coolant-fluid supply and return shut-off valves to reduce the amount of coolant-fluid leakage and consequential equipment and building damage. The shut-off valves must be sized to close-off against the maximum coolant-fluid system pressure in case of a catastrophic fluid leak.

The Vertiv™ Liebert® XDU450 is designed for use with a Primary (facility) supply of plain water or up to 20% glycol/water from a site chilled water ring main or a dedicated chiller. A 20% glycol concentration will give frost protection to approx. 16 °F (-9 °C). If a higher concentration of glycol is used, then the cooling capacity of the unit may have to be de-rated (contact manufacturer for advice).

It is the responsibility of the installer to make sure the primary water is filtered to a level of at least 500 micron, if the optional filter internal to the Liebert® XDU450 was not specified at time of order.

5.4.5 Secondary Liquid Specification

NOTICE

Risk of piping-system corrosion and freezing fluids. Can cause leaks resulting in equipment and very expensive building damage. Heat exchangers and piping systems are at high risk of freezing and premature corrosion. Fluids in these systems must contain the proper antifreeze and inhibitors to prevent freezing and premature coil and piping corrosion. When the cooling unit or piping may be exposed to freezing temperatures, charge the system with coolant fluid based on the coldest ambient design temperature. Automotive antifreeze is unacceptable and must NOT be used in any fluid system. Use only coolant fluid solution that meets the requirements of recommended industry practices. Do not use galvanized pipe.

The system coolant fluid must be analyzed by a competent fluid-treatment specialist before start up to establish the inhibitor and antifreeze solution requirement and evaluated at regularly scheduled intervals throughout the life of the system to determine the pattern of inhibitor depletion.

The fluid complexity and variants of required treatment programs make it extremely important to obtain the advice of a competent and experienced fluid-treatment specialist and follow a regularly scheduled coolant-fluid system-maintenance program.

Fluid chemistry varies greatly as do the required additives, called inhibitors, that reduce the corrosive effect of the fluids on the piping systems and components.

The chemistry of the coolant fluid used must be considered, because some sources may contain corrosive elements that reduce the effectiveness of the inhibited formulation. Sediment deposits prevent the formation of a protective oxide layer on the inside of the coolant system components and piping. The coolant fluid must be treated and circulating through the system continuously to prevent the buildup of deposits and/or growth of sulfate reducing bacteria. Proper inhibitor maintenance must be performed to prevent corrosion of the system.

Consult fluid manufacturer for testing and maintenance of inhibitors.

Commercial-grade coolant fluid is generally less corrosive to the common metals of construction than water itself. It will, however, assume the corrosivity of the coolant fluid from which it is prepared and may become increasingly corrosive with use if not properly inhibited.

Vertiv recommends installing a monitored fluid-detection system that is wired to activate the automatic-closure of field-installed coolant-fluid supply and return shut-off valves to reduce the amount of coolant-fluid leakage and consequential equipment and building damage. The shut-off valves must be sized to close-off against the maximum coolant-fluid system pressure in case of a catastrophic fluid leak.

The secondary circuit should be filled with particulate free coolant (see suggested specification below) treated with suitable corrosion inhibitors and biocides for the cooling application.

Failure to use proper water treatment can result in decreased system performance and reliability due to corrosion, scaling, fouling and microbiological growth and may invalidate the unit warranty.

Suitable Secondary circuit heat transfer fluid can be provided by the Vertiv™ Liebert® XDU450 supplier on request.

Table 5.1 Deionized Water Specification

Property	Value
Conductivity	< 15 μ S/0.4 in. (1 cm)
pH	6 to 8

Table 5.2 Mineral Content

Property	Value
Cadmium (Cd)	< 10 μ g/33.8 fl. oz. (1 L)
Copper (Cu)	< 10 μ g/33.8 fl. oz. (1 L)
Iron (Fe)	< 10 μ g/33.8 fl. oz. (1 L)
Lead (Pb)	< 10 μ g/33.8 fl. oz. (1 L)
Manganese (Mn)	< 10 μ g/33.8 fl. oz. (1 L)
Nickel (Ni)	< 10 μ g/33.8 fl. oz. (1 L)
Zinc (Zn)	< 10 μ g/33.8 fl. oz. (1 L)
Chloride (Cl)	< 2 μ g/33.8 fl. oz. (1 L)

6 Commissioning

6.1 Primary Circuit

6.1.1 Primary Pipework Installation

1. Confirm newly installed primary pipework has been correctly flushed (especially if any hot works have been carried out).
2. Confirm that the installed primary circuit pipework has been fitted with valves for unit isolation/maintenance.
3. Check supply/return connections are the correct way around.
4. Check that all pipe joints are tight.
5. Verify that newly fitted primary pipework and connections have been tested for leaks.

NOTE: We recommend isolating the unit with field-installed shutoff valves during leak checking of field-installed piping. When the units are included in a leak test, use of fluid for pressure testing is recommended. When pressurized gas is used for leak testing the unit, the maximum recommended pressure is 30 psig (207 kPa) and tightness of the unit should be verified by pressure decay over time, (<2 psig/hour [13.8 kPa/hour]) or sensing a tracer gas with suitable instrumentation. Dry seals in fluid valves and pumps may not hold a high gas pressure.

6. Check all primary circuit pipework, hoses, and valves have been insulated as per installation requirements.
7. Check that the external primary circuit has the means to vent air from the system, either automatically (preferable) or manually.
8. Verify water detection is properly installed around all units (recommended).

6.1.2 Facility Water Supply

1. Confirm Facility/Primary water supply is available prior to Vertiv™ Liebert® XDU450 installation and commissioning. If a dedicated chiller is to be utilized, ensure this has been fully commissioned at least 24 hours prior to Liebert® XDU450 commissioning.
2. Check that facility water or chiller has been connected to the Liebert® XDU450 primary water circuit.
3. Confirm there are no potential issues with low flow switches in the facility water circuit.
4. Confirm correct specification external filter is installed (see [Primary Liquid \(Facility\) Specification](#) on page 37), with isolation valves for maintenance (see [Primary Facility Circuit Connections](#) on page 23).
5. Verify that Facility/Primary water supply is fully operational and will provide sufficient flow rate/temperature at <145 psi (10 Bar)pressure, as per the original installation specifications.
6. Verify water detection is properly installed around all units (recommended).

6.1.3 Primary By-Pass Valve

If the end user has specified two-way cooling valve operation, check that the primary circuit by-pass valve has been closed (default position is open).

NOTE: With three-way valve operation, the water flow to/from the chiller will be reasonably constant. With two-way valve operation the flow to/from the chiller will vary 0 to 100% depending on valve position.

6.1.4 Primary Circuit Filling

1. Crack open the supply and return valves fitted in the pipework to the Vertiv™ Liebert® XDU450 unit to allow the primary circuit within the cabinet to gently fill from the chilled water supply. If the optional internal primary filter is fitted, check the filter valves are open and filter by-pass valve is closed.
2. Check circuit for leaks.

NOTE: Check that the installed primary chilled water system has an automatic water make-up facility and that filling the Liebert® XDU450 unit will not result in the chilled water system shutting down due to loss of water.

6.1.5 Primary Flow Setup

NOTE: Before attempting to monitor and adjust the Primary circuit flow, the operator should be fully knowledgeable with the operation of the Vertiv™ Liebert® XDU450 – refer to the XDU450 Operating and Maintenance Guide for more information.

For optimum performance, the primary water flow should be set to match the required heat load transfer and according to the primary inlet temperature and level of glycol (refer to XDU450 Application and Planning Guide for more information).

If the water flow is below the necessary requirement, there will be insufficient cooling and the load temperatures will start to rise. If there is too much flow, then the temperature control could become unstable.

An external means of restricting or by-passing excessive primary flow should be available in the external pipework.

To adjust the primary flow rate: Set the controller to 'Overrides' as described in [Unit Low Speed Circulation](#) on page 44 and adjust 'Cooling Valve' to 100%, this will force the cooling valve to open fully for maximum flow through the heat exchanger. Next go back to the 'Status' screen (second page) or Home screen to view the Primary flow rate.

Adjust external valve to regulate the flow through the Liebert® XDU450 to the required approximate setting.

6.2 Secondary Circuit

6.2.1 Secondary Pipework Connections

1. Check the manifold and drip tray have been installed in correct location (if applicable).
2. Check the manifold has been correctly flushed (especially if any hot works have been carried out).
3. Verify that newly fitted secondary pipework and connections, including hoses have been tested for leaks.

NOTE: We recommend isolating the unit with field-installed shutoff valves during leak checking of field-installed piping. When the units are included in a leak test, use of fluid for pressure testing is recommended. When pressurized gas is used for leak testing the unit, the maximum recommended pressure is 30 psig (207 kPa) and tightness of the unit should be verified by pressure decay over time, (<2 psig/hour [13.8 kPa/hour]) or sensing a tracer gas with suitable instrumentation. Dry seals in fluid valves and pumps may not hold a high gas pressure.

4. Check the leak detection tape (if applicable) has been installed into drip tray(s).
5. Check any hoses have been cut to the correct size, allowing sufficient length to ensure supply/return pipes will run smoothly from Vertiv™ Liebert® XDU450/manifold to racks without kinking.
6. Check all hose ends have been correctly labeled, e.g. Hose 1 from Liebert® XDU450 outlet 1 to rack 1 and supply/return flow direction.
7. Check all hoses have been correctly and neatly routed from the Liebert® XDU450/manifold to racks.
8. Confirm final connection of hoses to Liebert® XDU450/manifold and racks are tight.

6.2.2 Secondary Circuit Filling

NOTE: When filling and running the Secondary circuit, the operator should be fully knowledgeable with the operation of the Vertiv™ Liebert® XDU450 – refer to the XDU450 Operating and Maintenance Guide for more information.

1. Position container of pre-treated deionized water in front of the Liebert® XDU450.
2. Ensure all automatic air vent bleed screws are loose, but not removed (located at the top of each filter housing and on discharge header).
3. Insert the filling wand into the container, then connect fill wand hose to the fill pump quick release coupling.
4. Log on to the controller with the "Service" access code (5699).
5. Select 'Fill Pump Request', then the fill pump will start pumping the cooling liquid into the system at the rate of approximately 1 gpm (4 l/m).
6. The fill pressure (PS1) can be monitored under the Status screen – Page 3, during filling.
7. Observe the water level of container and stop the fill pump by 'Fill Pump Request' before changing the water container.
8. Repeat the process with more water containers until the fill pump automatically stops.
9. Pump will stop when inlet pressure PS1 reaches the default 15 psi (1 bar).
10. Manually vent air from the expansion vessel pipes by depressing the Schrader valves located beneath each vessel (fill pump may re-start).
11. Leave the filling wand connected and in the container of water as more air will be expelled during the initial operation.
12. Check for leaks.

The **Figure 6.1** below shows the unit pressure monitoring and fill pump control during filling operation as part of commissioning (unit off-line):

Figure 6.1 Pressure Monitoring and Filling Operation

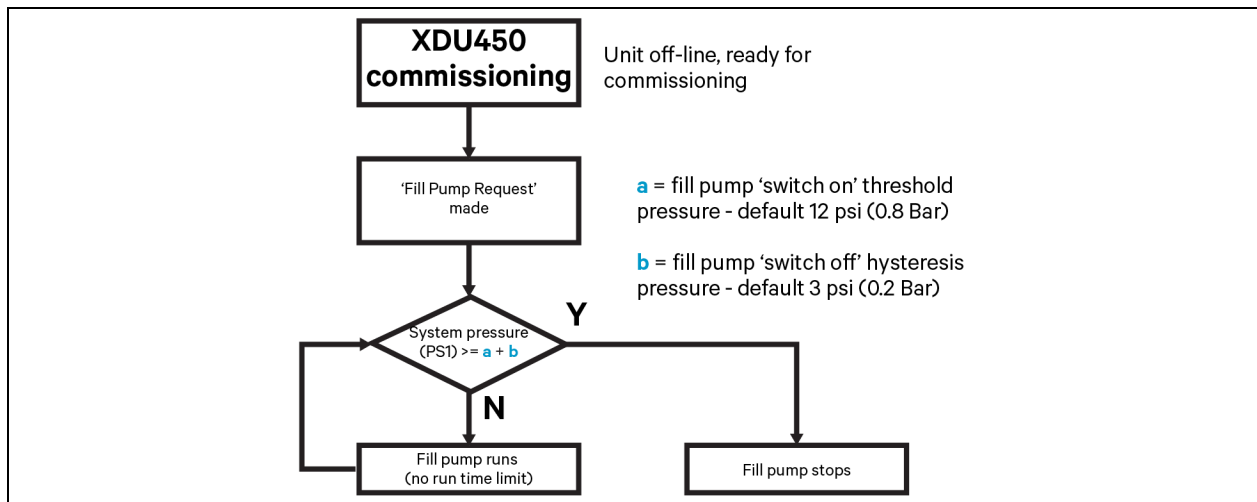

6.3 Unit Configuration

Prior to running the Vertiv™ Liebert® XDU450, the configuration should be checked to ensure the unit is set up according to the site requirements.

Flow or DP control – See Configuration menu/Pump Control/Flow or DP (P201). This will control the pump speed according to the required flow rate or differential pressure.

Flow/DP set point – See Configuration menu/Flow Setpoint (P202) or Differential Setpoint (P203). This will set the required flow or differential pressure to be achieved.

NOTE: It's best to leave these values at default, then set at the final stages of commissioning.

Single or twin pump operation – See Configuration menu/Twin Pump Control (P208)/Single or Twin. Single pump setting operates the pumps as run/standby. Twin pump setting allows both pumps to be run simultaneously.

NOTE: Twin pump setting is only available on the 480 volt model .

Over Pressure Action – See Configuration menu/Pump Control/Over Pressure Action (P212)/Alarm, Alarm + Shutdown or Alarm + Back-off. This will determine if the unit should continue to run (with or without back-off control) or shutdown in the event of a system over pressure situation.

Temperature control Mode – See Configuration menu/Temperature Control/Control Mode (P302)/Fixed Setpoint or Fixed Setpoint and Dew Point Override. This will either keep the Secondary supply temperature at a fixed temperature or allow it to rise if there is a danger of condensation.

Leak detection – See Configuration menu/Leak Detection - Flood Tray (P601) and Leak Detection - Underfloor (P602)/Alarm or Shutdown and Alarm. This will determine if the unit should continue to run or shutdown in the event of an internal or external leak.

Power failure option – See Configuration menu/Miscellaneous/Post Power Failure Options (P904)/Run or Standby. This will determine if the unit will automatically re-start or remain in standby after a power outage.

Communications – See Setup menu.

6.4 Unit Low Speed Circulation

After the initial fill process, it is advisable to run the unit at a reduced pump speed to gently circulate the water - enabling any trapped air to vent out through the auto air vents. If the Flow/DP setpoints have been left at the default values, then this will happen naturally as these values have been deliberately set quite low. Manually vent the expansion vessels at the Schrader points.

To adjust the pump speed with the Overrides function:

1. Start the unit in normal automatic mode and allow the pump speed(s) to settle at the default Flow or DP setpoint.

NOTE: The minimum allowable pump speed is 15%, to enable adequate motor fan cooling and the default Flow/DP may not be achieved if it requires the pump to operate below this speed - will depend on system impedance.

2. Leave the unit running like this for approx. 30 minutes to allow any trapped air to vent.

NOTE: While the main pump is running, the fill pressure at PS1 may drop as air is purged from the system and the fill pump may automatically re-activate again.

6.5 Overrides and Full Speed Operation

After this period of reduced speed running, the pump speed(s) can be ramped up to full 100% speed to determine full flow/DP maximum performance available. Ideally the system should be a complete installation with all IT load circuits connected.

1. Go to the 'Logon' screen and enter the 'Service' access code (5699).
2. Go to the Service menu and select 'Overrides'. Select either 'Pump 1 Speed' or 'Pump 2 Speed' as required and enter the desired speed as a percentage of full 60 Hz operation, followed by the OK button. If the unit is configured for 'Twin Pump Control'; repeat for second pump.



The display will show the  icon on the Home screen all the time this function is operational.

NOTE: If there is no interaction with the touchscreen for 15 minutes (default) or more, the controller will revert to full automatic mode.

Once satisfied that all air has been expelled from the system and the Vertiv™ Liebert® XDU450 maximum performance has been achieved, the pump operation can be set back to automatic control. Go back into Overrides and set the pump speed(s) back to 0%, which will put the control back into automatic mode. The final required flow rate or DP can then be set in the Configuration menu/Pump Control/Flow Setpoint (P202) or Differential Pressure Setpoint (P203).

6.6 Pump Rotation



WARNING! Risk of improper wiring, piping, moving, lifting and handling. Can cause serious injury or death. Building and equipment damage may also result. Installation and service of this equipment should be done only by qualified personnel who have been specially-trained in the installation of air-conditioning equipment and who are wearing appropriate, OSHA-approved PPE.

NOTICE

Risk of improper electrical connection of three-phase input power. Can cause backward pump rotation and unit damage. Service technicians should use a gauge set on the system during the initial start up to verify that the three-phase power is connected properly. Three-phase power must be connected to the unit line voltage terminals in the proper sequence so that the pump rotates in the proper direction. Incoming power must be properly phased to prevent pump from running backward. We recommend checking the unit's phasing with proper instrumentation to ensure that the power connections were made correctly. We also recommend verifying discharge and suction pressures during start up to ensure that the pumps are running in the correct direction.

Once running, the pump rotation direction should be checked. This should be counterclockwise when viewed on the pump end (fan cowl). The pumps are fitted with a direction indicator flag located on the fan cowl: if the flag is 'black', then rotation is correct, if flag is white, then pump running clockwise/reverse.

If the direction is clockwise then invert 2 – phases on the electrical supply connection.

Figure 6.2 Indicator Flag Location

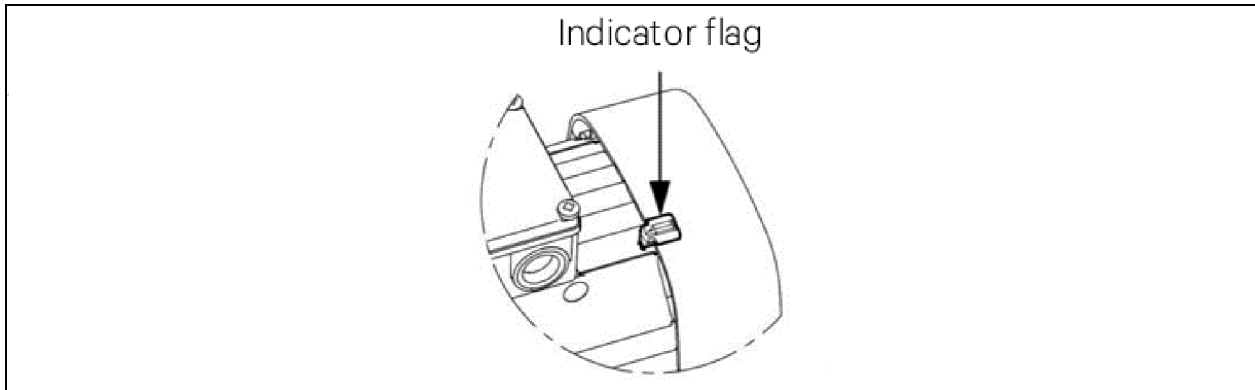

6.7 Full Manual Control

The Full Manual Control mode can be accessed from the Service screen (when logged-on at Engineering level) and may be used when just one or more outputs need to be manually controlled in total isolation from the automatic operation of the rest of the unit.

Selection causes the unit to shut down and all outputs will be inactive unless manually set and all alarms will be ignored (see Installation and Commissioning manual for more information).

It's unlikely that this function will be required while commissioning, Full Manual Control is more usually used during fault finding.

NOTE: If the unit was previously running in Automatic mode, as soon as Full Manual Control is selected, the unit will shut down completely.

6.8 Subsequent Filling



WARNING! Risk of improper wiring, piping, moving, lifting and handling. Can cause serious injury or death. Building and equipment damage may also result. Installation and service of this equipment should be done only by qualified personnel who have been specially-trained in the installation of air-conditioning equipment and who are wearing appropriate, OSHA-approved PPE.



CAUTION: Risk of contact with extremely hot or cold surfaces. Can cause injury. Verify that all components have reached a temperature that is safe for human contact or wear appropriate, OSHA-approved PPE before working with the electric connection enclosures or unit cabinet. Perform maintenance only when the system is de-energized and component temperatures have become safe for human contact.



CAUTION: Risk of improper piping installation, leak checking, fluid chemistry and fluid maintenance. Can cause injury. Building and equipment damage may also result. Installation and service of this equipment should be done only by qualified personnel who have been specially-trained in the installation of air-conditioning equipment and who are wearing appropriate, OSHA-approved PPE.

NOTICE

Risk of piping-system corrosion and freezing fluids. Can cause leaks resulting in equipment and very expensive building damage. Heat exchangers and piping systems are at high risk of freezing and premature corrosion. Fluids in these systems must contain the proper antifreeze and inhibitors to prevent freezing and premature coil and piping corrosion. When the cooling unit or piping may be exposed to freezing temperatures, charge the system with coolant fluid based on the coldest ambient design temperature. Automotive antifreeze is unacceptable and must NOT be used in any fluid system. Use only coolant fluid solution that meets the requirements of recommended industry practices. Do not use galvanized pipe.

The system coolant fluid must be analyzed by a competent fluid-treatment specialist before start up to establish the inhibitor and antifreeze solution requirement and evaluated at regularly scheduled intervals throughout the life of the system to determine the pattern of inhibitor depletion.

The fluid complexity and variants of required treatment programs make it extremely important to obtain the advice of a competent and experienced fluid-treatment specialist and follow a regularly scheduled coolant-fluid system-maintenance program.

Fluid chemistry varies greatly as do the required additives, called inhibitors, that reduce the corrosive effect of the fluids on the piping systems and components.

The chemistry of the coolant fluid used must be considered, because some sources may contain corrosive elements that reduce the effectiveness of the inhibited formulation. Sediment deposits prevent the formation of a protective oxide layer on the inside of the coolant system components and piping. The coolant fluid must be treated and circulating through the system continuously to prevent the buildup of deposits and/or growth of sulfate reducing bacteria. Proper inhibitor maintenance must be performed to prevent corrosion of the system.

Consult fluid manufacturer for testing and maintenance of inhibitors.

Commercial-grade coolant fluid is generally less corrosive to the common metals of construction than water itself. It will, however, assume the corrosivity of the coolant fluid from which it is prepared and may become increasingly corrosive with use if not properly inhibited.

Vertiv recommends installing a monitored fluid-detection system that is wired to activate the automatic-closure of field-installed coolant-fluid supply and return shut-off valves to reduce the amount of coolant-fluid leakage and consequential equipment and building damage. The shut-off valves must be sized to close-off against the maximum coolant-fluid system pressure in case of a catastrophic fluid leak.

NOTICE

Risk of no-flow condition. Can cause equipment damage. Do not leave the water/coolant fluid-supply circuit in a no-flow condition. Idle fluid allows the collection of sediment that prevents the formation of a protective oxide layer on the inside of the tubes. Keep unit switched On and water/ coolant fluid-supply circuit system operating continuously. In multiple unit teams, allow standby units to enter the rotation automatically or schedule regular manual rotations.

NOTICE

Risk of leaking chilled water lines. Can cause equipment and building damage.

Lines and joints must be inspected regularly. Improper installation, application and service practices can result in water leakage from the unit. Water leakage can result in severe property damage and loss of critical data center equipment. Do not locate unit directly above any equipment that could sustain water damage.

Vertiv recommends installing monitored leak detection equipment for the unit and supply and return lines.

NOTICE

Risk of a catastrophic water circuit rupture. Can cause expensive building and equipment damage.

Install an overflow drain pan under the unit with a monitored leak detection system in the pan and shutoff valves in the supply and return water lines that automatically close if water is detected by the leak detection system.

The shutoff valves should be spring return and must be rated for a close-off pressure that is the same as or higher than the supply water pressure. If it is not possible to install an overflow drain pan, then a monitored leak detection system should be installed in the base of the unit or under the unit to actuate the shutoff valves immediately on a leak detection signal.

The overflow drain pan should have a drain line connected to it that flows to a floor drain or maintenance sink in case of a shutoff valve or leak detection system malfunction.

Once the unit is commissioned - the filling wand may be disconnected and the flexible make-up container (approximately 0.5 gal. (2 l) capacity, filled with coolant) may be connected in its place, which will allow the unit to self-fill while unattended, in the event of minor water loss or when any remaining trapped air is purged out of the system.

The container should be regularly inspected during service visits and refilled if required, although any fill pump activity after commissioning greater than 5 seconds duration will be raised as an 'A38 - Check Water Make-up Level' alarm, as a reminder for investigation.

Before connecting the make-up container, the air in the container hose should be purged. Fill the container with water, screw on the fill cap and then squeeze the bag while depressing the valve on the end of the quick release coupling until air is expelled and hose is full of water.

If there is already pressure in system and air is introduced into the fill pump suction line, then the fill pump may cease to pump. To rectify; leave the unit running while opening a drain valve to relieve pressure, until fill pump starts to pump again.

Appendices

Appendix A: Technical Support and Contacts

A.1 Technical Support/Service in the United States

Vertiv Group Corporation

24x7 dispatch of technicians for all products.

1-800-543-2378

Liebert® Thermal Management Products

1-800-543-2778

Liebert® Channel Products

1-800-222-5877

Liebert® AC and DC Power Products

1-800-543-2378

A.2 Locations

United States

Vertiv Headquarters

1050 Dearborn Drive

Columbus, OH, 43085, USA

Europe

Via Leonardo Da Vinci 8 Zona Industriale Tognana

35028 Piove Di Sacco (PD) Italy

Asia

7/F, Dah Sing Financial Centre

3108 Gloucester Road, Wanchai

Hong Kong

This page intentionally left blank

This page intentionally left blank

Appendix C: Warranty Details

C.1 Limited Product and Service Warranty

Extended warranties, service and maintenance programs are available in most locations, details available upon request. To obtain further details of limited warranty, also after sales service offerings, contact your local sales representative or technical support if you have any questions or problems during unit installation.

This page intentionally left blank

Appendix D: Automatic Transfer Switch Installation and Commissioning

D.1 Product Description

General

This document describes the physical and electrical characteristics of the Vertiv™ Liebert® XDU450 Automatic Transfer Switch (ATS) for Installation and Commissioning purposes.

The ATS allows the Liebert® XDU450 unit to be connected to 'A' and 'B' electrical supplies. Supply 'A' will be the default power source, but should this supply fail for any reason, then the ATS unit will seamlessly switch over to Supply 'B', without any stoppage or function loss in the Liebert® XDU450.

When Supply 'A' comes back on-line, the ATS will automatically switch back to this supply as the default.

Reasons for Supply Switchover

Listed below are the issues that will trigger a switchover from Supply 'A' to Supply 'B'.

1. Complete supply failure
2. Individual phase loss
3. Incorrect phase sequence
4. Over voltage
5. Under voltage

Product Views

Figure D.1 Front view of ATS

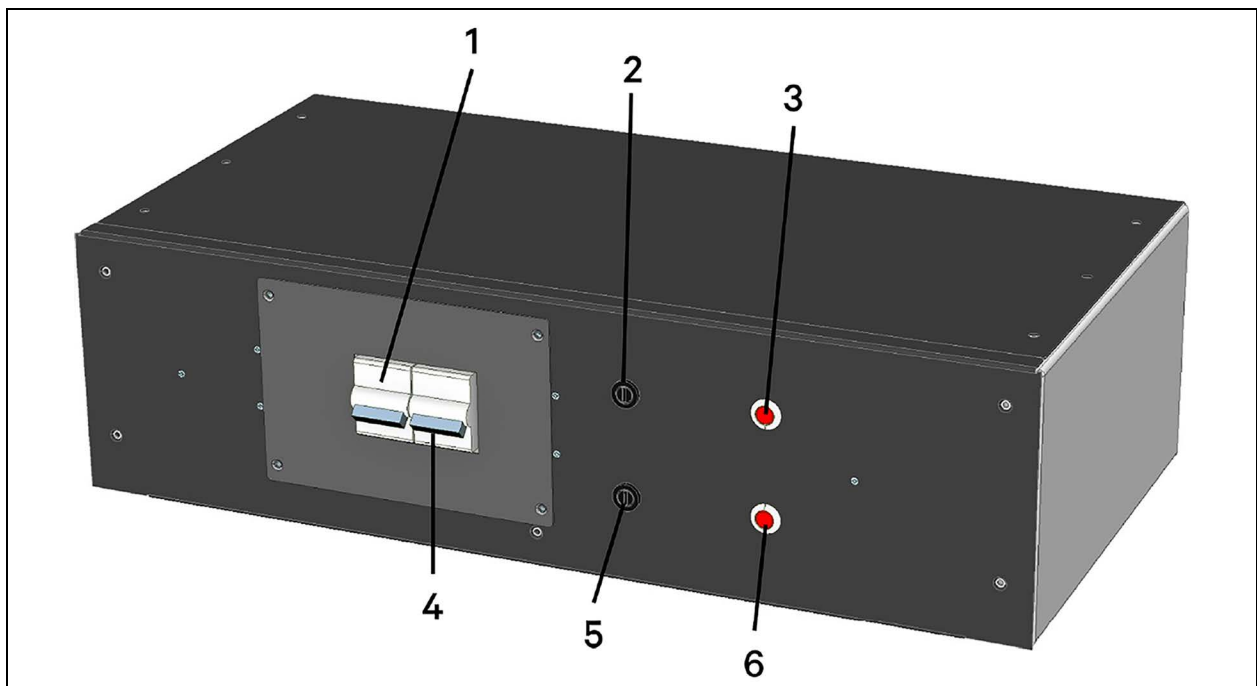

Item	Description
1	MCB for Supply 'A' PSU
2	Supply 'A' DC control fuse
3	Supply 'A' activated indicator
4	MCB for Supply 'B' PSU
5	Supply 'B' DC control fuse
6	Supply 'B' activated indicator

Figure D.2 Rear and Inner View of ATS

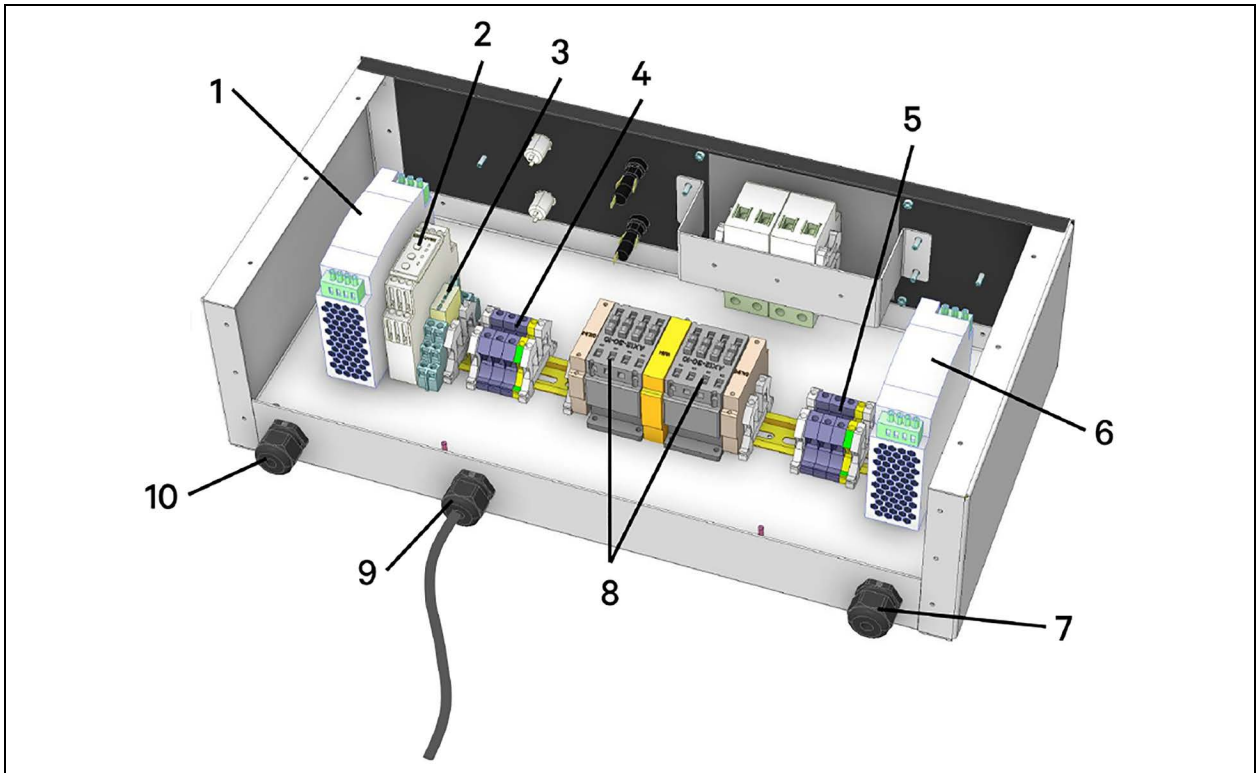

Item	Description
1	PSU for Supply 'B'
2	Phase Failure Relay
3	Relay
4	Cable terminations for Supply 'B'
5	Cable terminations for Supply 'A'
6	PSU for Supply 'A'
7	Cable gland entry for Supply 'A'

Item	Description
8	Contractors
9	Cable gland exit for supply to Liebert® XDU450 (cable supplied pre-fitted)
10	Cable gland entry for Supply 'B'

Technical Data

Table D.1 Unit Dimensions

Base Unit	Width		Depth		Height	
	in.	mm	in.	mm	in.	mm
Maximum	23.6	600	32.3	821	6.3	160

Table D.2 Shipping Dimensions

Base Unit	Width		Depth		Height	
	in.	mm	in.	mm	in.	mm
Maximum	27.6	700	35.4	900	9.0	230

Table D.3 Weight

Base Unit	Operating		Shipping	
	lbs.	kg	lbs.	kg
Maximum	33	15	44	20

Table D.4 Conditions

Base Unit	
Operating	41 °F to 104 °F (5 to 40 °C) - ambient, 10 to 80%RH (non-condensing)
Storage	-4 °F to 149 °F (-20 to 65 °C), 5 to 95%RH (non-condensing)

Electrical Data

Table D.5 Supported Power Supplies

Voltage	FLA	WSA	OPD
208*	16.8	35	50
480**	15.0 A	36 A	45 A
Installed load	12.5 kVA (max.)		

Table D.5 Supported Power Supplies (continued)

Voltage	FLA	WSA	OPD
Typical power		7.5 kW	
* Tolerance on three phase power is 208 V (+/- 5%), 60 Hz (+/- 3 Hz)			
** Tolerance on three phase power is 480 V (+/- 5%), 60 Hz (+/- 3 Hz)			

D.2 Installation

NOTE: If the XDU is supplied with a factory installed ATS, continue to [Electrical Installation](#) on page 60

Unpacking and Positioning

On arrival at site, the Vertiv™ Liebert® XDU450 ATS should be unpacked from the shipping crate and checked for any signs of external transit damage (any serious damage must be reported to manufacturer and shipper immediately, prior to installation).

The Liebert® XDU450 ATS is designed to fit on top of the XDU450 cabinet.



WARNING! Installation of the ATS to the top of the Liebert® XDU450 cabinet will require a minimum of two operatives.

Mechanical Installation

1. First loosen (but do not remove) the 4 x M4 screws holding the front section of the cabinet roof.
2. With the screws loose, the roof panel can be slid forwards, then lifted up to release (see **Figure D.3** on the facing page).
3. Place the left and right hand ATS side panels on top of the cabinet and fix in position using the 4 x M4 screws remaining from the roof panel (see **Figure D.4** on the facing page).
4. Remove the cover panel of the ATS box (panel earth cable can be disconnected to allow full removal), then splay the fixed side panels apart slightly to allow the ATS box to drop between.
5. Once positioned between the side panels, the ATS box can be screwed in position with 3 x M4 screws on either side (see **Figure D.5** on page 60).
6. Loosely screw in 4 x M4 screws to the top faces of the side panels for re-location of the roof panel, once installation is complete.
7. Fix the rear panel into position with 4 x M4 screws as shown (see **Figure D.5** on page 60).

Figure D.3 Roof Panel Removal

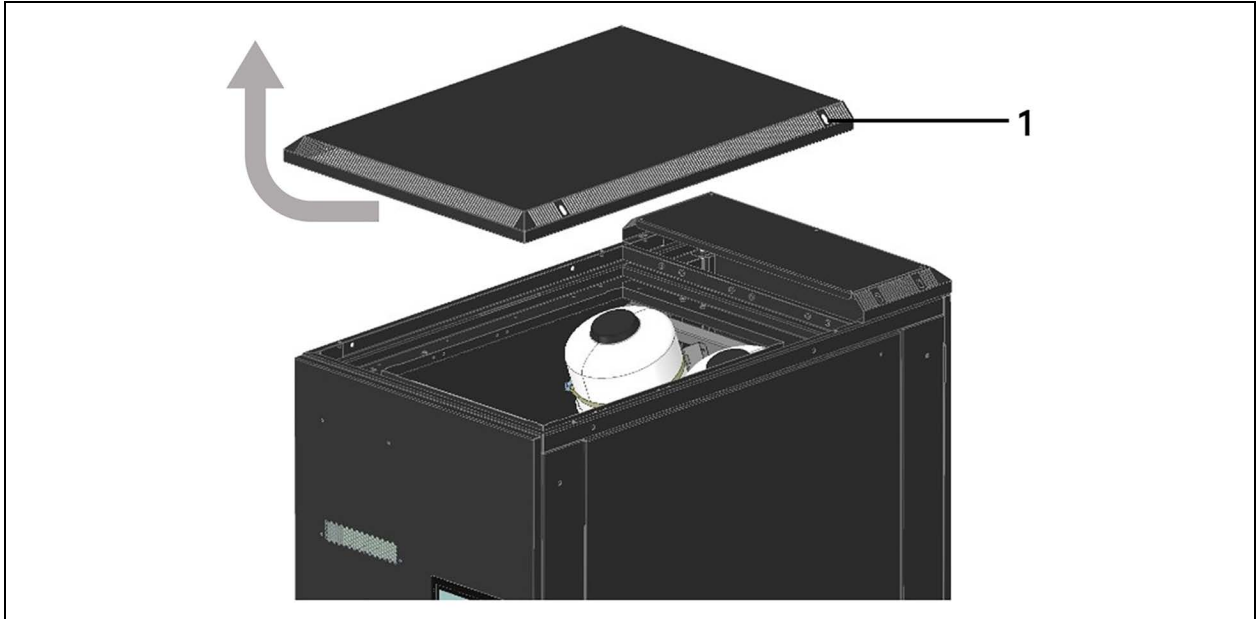

Item	Description
1	Loosen 4 x M4 roof panel retaining screws. When the screws are released, slide the roof panel forward, then lift to free.

Figure D.4 Initial ATS Installation

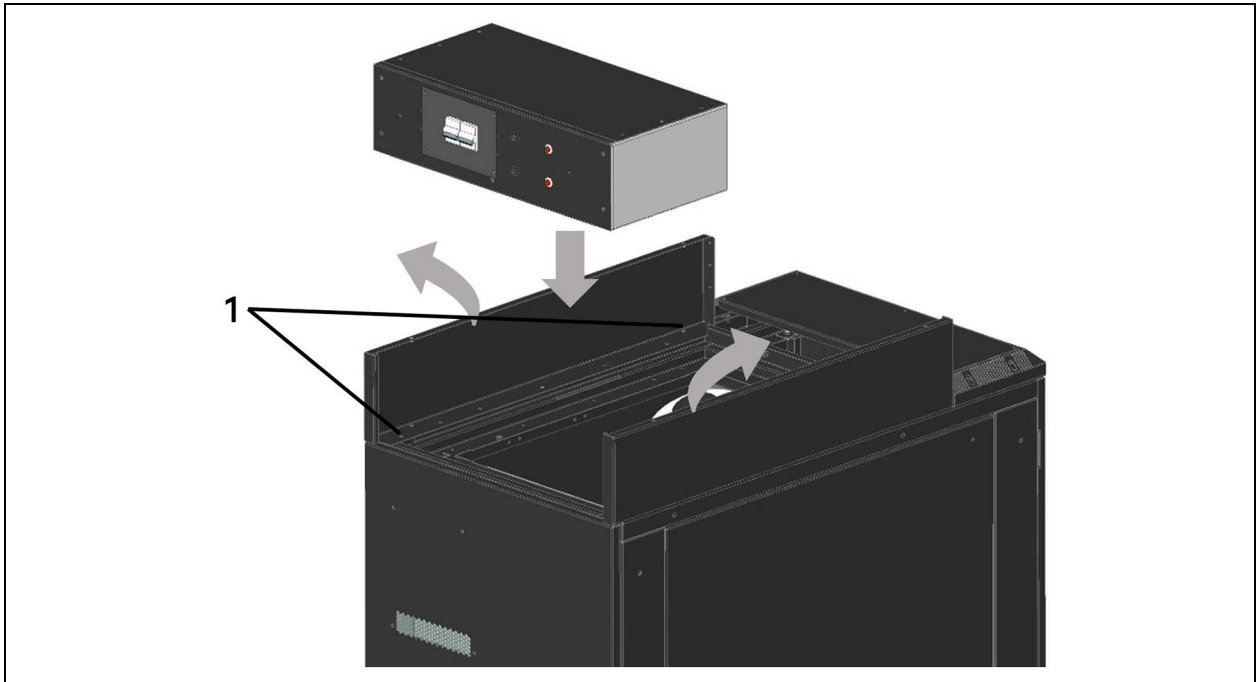

Item	Description
1	Splay side panels apart slightly to allow ATS box to drop between. Position and fix down the left and right-hand side panels to the top of the cabinet, using the M4 screws left from the roof panel.

Figure D.5 Full ATS Installation

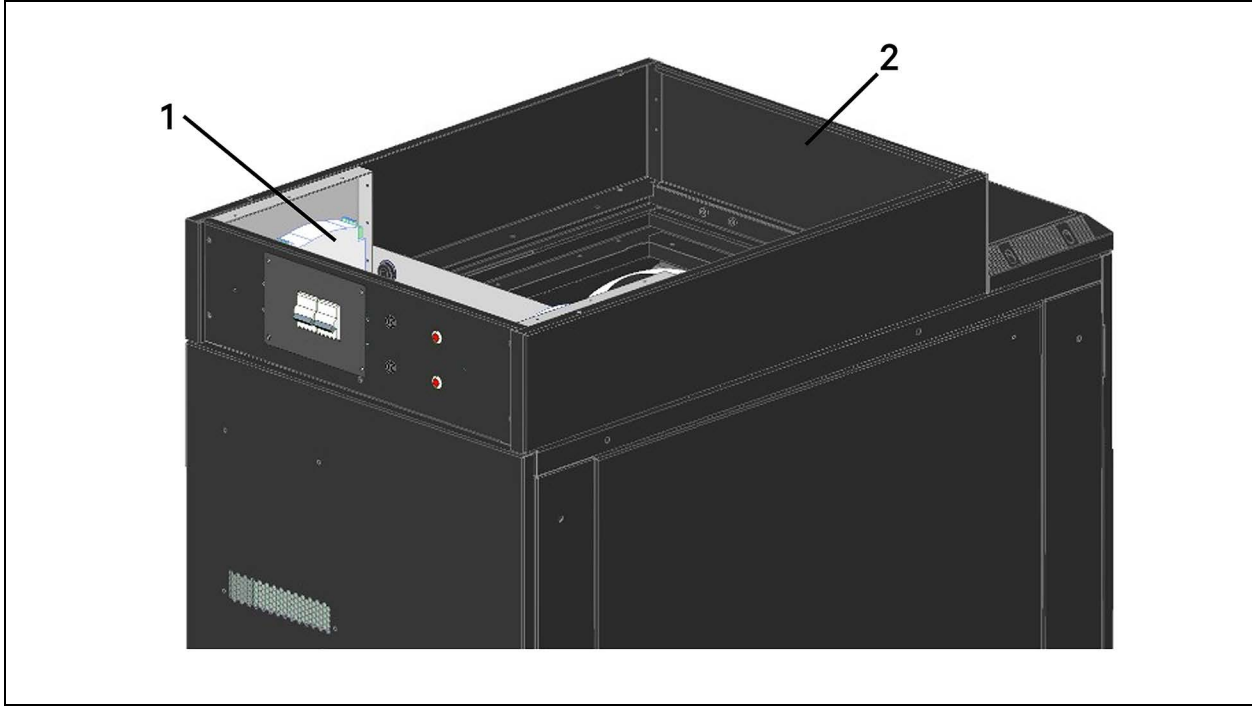

Item	Description
1	Remove the cover from the ATS box and screw the base of the box to the side panels (3 x M4 fixings either side).
2	Fit rear panel to the two side panels with M4 screws.

D.3 Electrical Installation

With the ATS mechanically installed, the A and B electrical connections can be made.



WARNING! This unit is powered by HIGH VOLTAGE. Serious injury or death can occur. All electrical work must only be carried out by a suitably qualified electrician.

1. Route the 4-core flying cable, supplied with the ATS, down the back of the Vertiv™ Liebert® XDU450 electrical panel and in through the cable gland provided. Terminate this cable as normal to the Liebert® XDU450 disconnect switch (isolator) and adjacent ground (earth) terminal (refer to XDU450 Installation and Commissioning Guide for more information, if required).
2. The incoming 'A' and 'B' supply cables can be routed over the safety edge of the ATS rear panel (see **Figure D.6** on the facing page), then routed down and through the 1 in. (25 mm) cable glands provided on the back of the ATS box. The cable glands will accept cable diameters between 3/8-5/8 in. (9 -16 mm).

3. The recommended cable size should be 4-core 4.0 mm² (11AWG) minimum (or can be 2.5 mm² if run/standby pump operation only).
4. Upstream protection must be provided by the end user in the form of fuses or breakers in accordance with the maximum loads stipulated on the wiring diagram and in accordance to local regulations.
5. Terminals are provided inside the ATS box for power cable termination (see **Figure D.2** on page 56).
6. The 'A' and 'B' power cables can be fixed to the rear panel safety edge if required.

Figure D.6 ATS Wiring

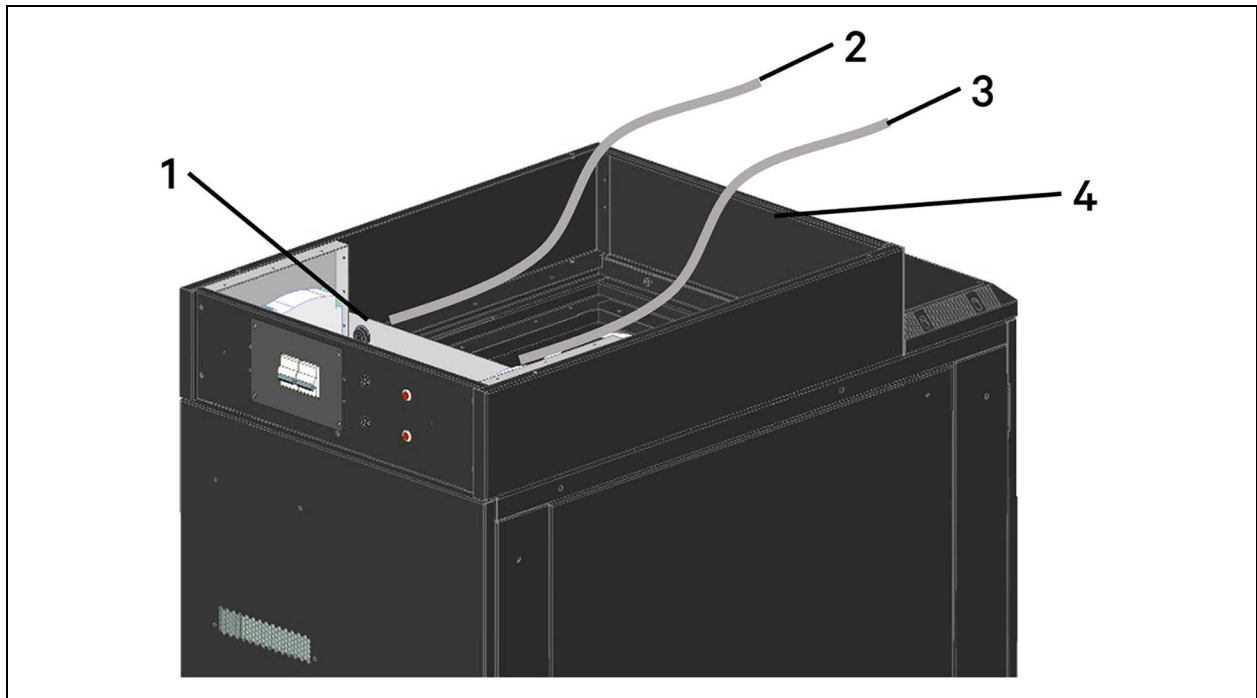

Item	Description
1	Cable gland entry to ATS box
2	Supply 'A'
3	Supply 'B'
4	Safety edge on ATS rear panel for cable protection. Cables can be anchored here as required.

Electrical Checks



WARNING! This unit is powered by HIGH VOLTAGE. Serious injury or death can occur. All electrical work must only be carried out by a suitably qualified electrician.

1. Confirm installed Vertiv™ Liebert® XDU450 model and associated ATS is suitable for site supply voltage.
2. Check that the ATS has been connected to power supply, with a minimum of 4-core 4.0mm² (2.5mm² for run/standby pump operation) power cable.
3. Verify that the rating of the circuit breaker/fuses supplying the ATS meets specification and rating as dictated by the latest wiring diagram.

4. Check and record the voltage available across each of the 3 phases meets Vertiv™ Liebert® XDU450 model requirements.
5. Confirm that all electrical connections are tight and have been safety tested/certified.

Completion

1. Re-attach the earth cable to the ATS cover panel, then screw the cover panel in place on the ATS box with M4 screws.
2. Install the roof panel in position on top of the ATS to complete the installation.

D.4 Commissioning

Phase Failure Relay

On arrival at site, the Vertiv™ Liebert® XDU450 ATS should be pre-set to suit the site voltage. However, it is recommended that prior to connection of the power supplies, the settings of the phase failure relay are checked according to the information in [Phase Failure Relay \(DIP switch positions\)](#) below .

Phase Failure Relay (DIP switch positions)

The DIP switches on the phase failure relay are located on the underside, so to check the position of these it will require the removal of the relay from the DIN rail.

The DIP switches should be set according to **Table D.6** on the facing page , selecting a voltage that is closest to the actual site voltage.

Figure D.7 DIP Switch Pins

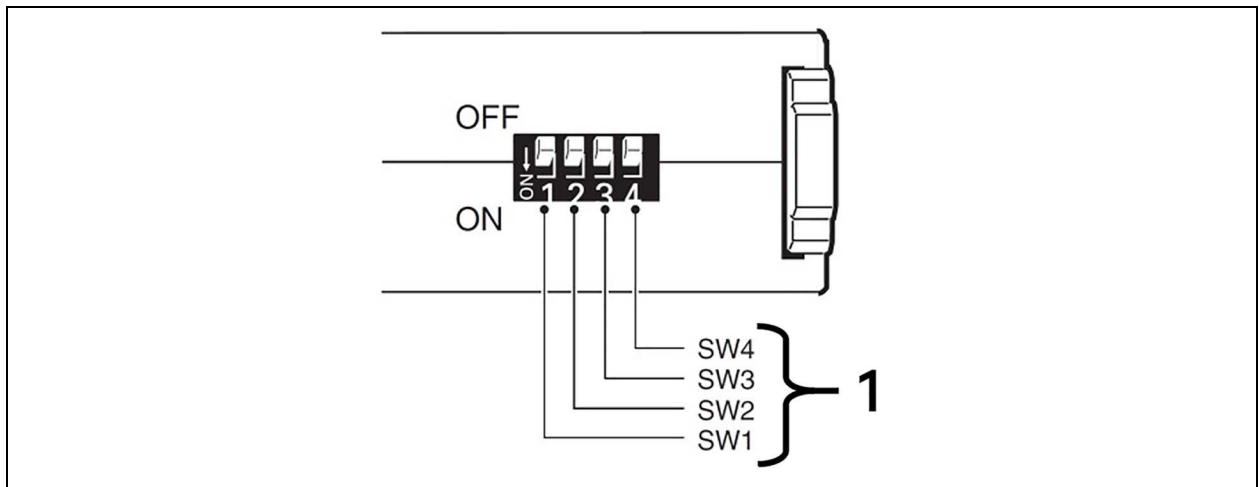

Item	Description
1	DIP Switch Pins

Table D.6 Voltage and DIP Switch Positions

Voltage Settings	Relay Model Number	DIP Switch Positions			
		SW1	SW2	SW3	SW4
200 v	K8AK-PW1	Off	Off	Off	Off
380 v	K8AK-PW1	Off	Off	Off	Off
400 v	K8AK-PW1	Off	Off	On	Off
415 v	K8AK-PW1	Off	Off	Off	On
480 v	K8AK-PW1	Off	Off	On	On

Phase Failure Relay (under/over voltage thresholds)

The under and over voltage trip thresholds are supplied from the factory set to nominal values and these may require adjustment to the customer's preference.

Figure D.8 Voltage Trip Thresholds

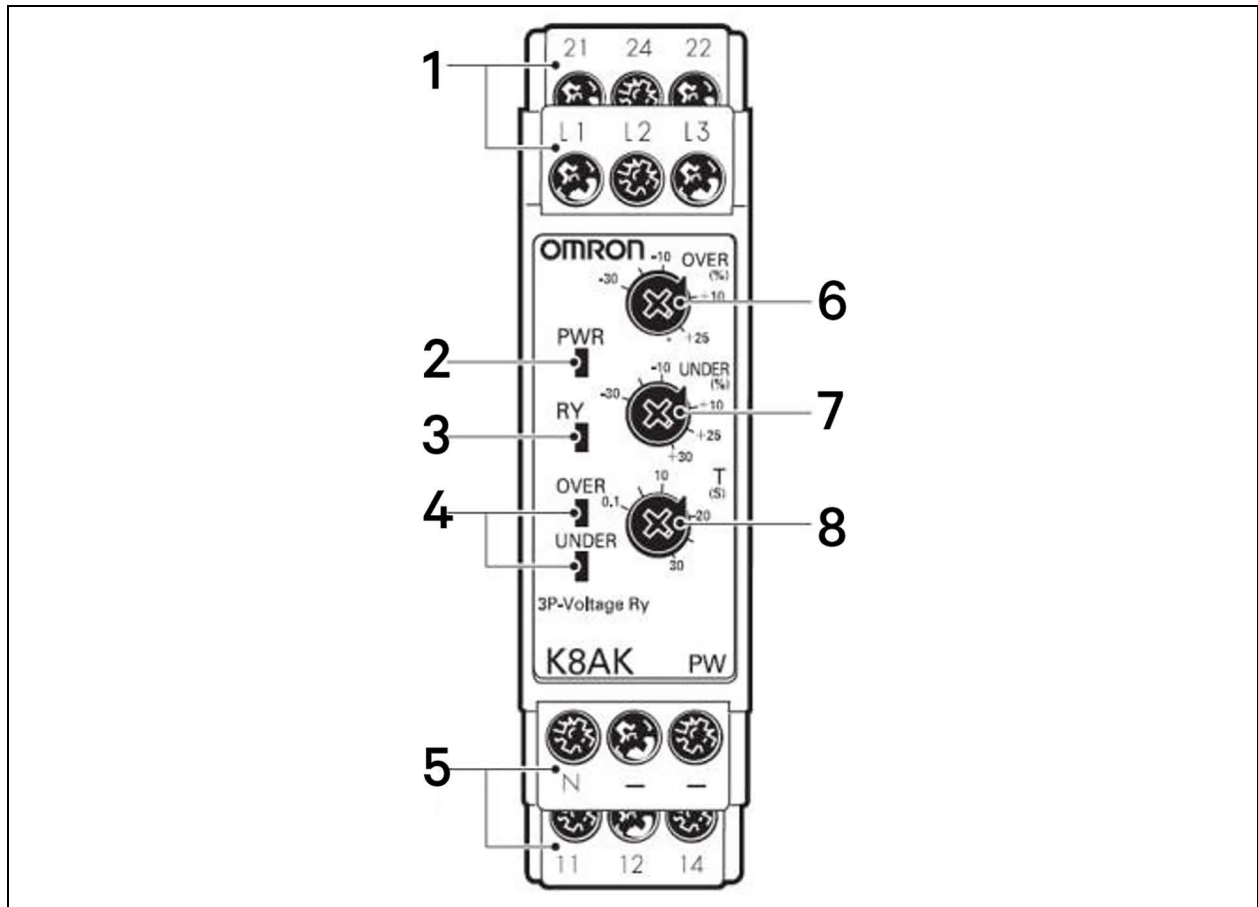

Item	Description
1	Terminal block
2	Power indicator
3	Relay status indicator
4	Alarm indicator
5	Terminal block
6	Over-voltage knob (Over)
7	Under-voltage knob (Under)
8	Operating time knob (T)

In order to facilitate accurate over/undervoltage trip thresholds, the DIP switches should be set to a voltage that is closest to the actual site voltage, as shown in **Table D.6** on the previous page .

Example: If the site voltage is 480 v and the relay has been set for 480v, then adjusting the overvoltage dial to +5% will set the trip threshold at, or above 504 v. Similarly, for the undervoltage, setting the dial to -5% will set the trip threshold at, or below 456 v.

NOTE: If the site voltage is outside the pre-defined DIP switch settings, then the over/undervoltage dials will need to be set slightly differently.

Example: If the site voltage is 460 v, the nearest DIP switch setting will still be 480 v. However to achieve 460 v \pm 5% trip thresholds of 483 v (460v +5%) and 437 v (460 v -5%), the over-voltage dial will need to be set to +1% (i.e. 480 v +1% = 483 v) and the under-voltage dial will need to be set to -9% (i.e. 480v -9% = 437 v). A similar approach will need to be taken for a site voltage of 208 v, for the 200 v relay setting.

Phase Failure Relay (operating time)

The operating time knob determines how much of a time lag there is in an under/over voltage situation before the relay trips (adjustable 0.1 to 30 seconds) and initiates a power supply changeover from 'Supply A' to 'Supply B'.

As soon as 'Supply A' returns to a healthy condition, the ATS unit will automatically revert to Supply A as the default supply.

This page intentionally left blank

Appendix F: Disposal Information

NOTE: Waste materials must be disposed of in a responsible manner in line with environmental regulations.

The de-commissioning and disposal of this product should be undertaken by qualified personnel in adherence to local and national safety regulations, particularly for protection of lungs, eyes and skin from chemicals, dust etc. Approved lifting gear and power tools should be used and access to the work area must be restricted to authorised personnel.

The following steps are a guide only and should be adjusted to take into account local site conditions:

1. Disconnect unit from electrical supply.
2. Drain and dispose of any heat transfer fluid through an approved recycling facility.
3. Remove unit to approved recycling facilities only.

This page intentionally left blank

Connect with Vertiv on Social Media



<https://www.facebook.com/vertiv/>



<https://www.instagram.com/vertiv/>



<https://www.linkedin.com/company/vertiv/>



<https://www.twitter.com/Vertiv/>



Vertiv.com | Vertiv Headquarters, 1050 Dearborn Drive, Columbus, OH, 43085, USA

© 2022 Vertiv Group Corp. All rights reserved. Vertiv™ and the Vertiv logo are trademarks or registered trademarks of Vertiv Group Corp. All other names and logos referred to are trade names, trademarks or registered trademarks of their respective owners. While every precaution has been taken to ensure accuracy and completeness here, Vertiv Group Corp. assumes no responsibility, and disclaims all liability, for damages resulting from use of this information or for any errors or omissions. Specifications, rebates and other promotional offers are subject to change at Vertiv's sole discretion upon notice.

SL-70624_REVB_07-22