



# VERTIV™ AVOCENT® VHX131L | VHX231L

## HDMI Matrix KVM over IP Extender

Installer/User Guide

Version 1.0 | November | 2024



**VHX131LT/VHX131LR**

**VHX231LT/VHX231LR**

## **User's Manual**

Version V1.0

Revision date 2024-11-15

---

We provide customers with total-solution technical support. Users may contact our nearest local sales office or service center, or directly contact our Corporate.

© Copyright 2024

All rights reserved. The contents in this document are subject to change without notice.

**EMI Statements:** Products which are certified for EMC in the regions or countries indicated will have the required marking or statement on the product label. The applicable statement for that country is listed below.

China warns the users that this is a Class A information product, which may cause radio frequency interference when used in the living environment. In this case, users will be required to take some appropriate countermeasures.

**Technical Support Site:** If you encounter any installation or operational issues with your product, check the pertinent section of this manual to see if the issue can be resolved by following outlined procedures. For additional assistance, please contact our technical department.

Thanks for purchasing this Virtual Matrix KVM over IP Extender. With our highly reliable and quality product, you can enjoy countless benefits by using them.

## Table of the Contents

Chapter 1 Introduction.....	1
Chapter 2 Features .....	2
Chapter 3 Package Contents .....	3
Chapter 4 Specification .....	4
4.1 VHX131LT/VHX131LR Specification .....	4
4.2 VHX231LT/VHX231LR Specification .....	4
Chapter 5 Product Overview .....	5
5.1 VHX131LT/VHX131LR .....	5
5.2 VHX231LT/VHX231LR .....	7
Chapter 6 Connection Diagram .....	8
6.1 Before Connection .....	8
6.2 System Deployment with Direct Connection .....	8
6.3 System Deployment with Network Switch Connection .....	9
Chapter 7 Operation.....	11
7.1 Front Panel Buttons and LED Indication .....	11
7.1.1 Functions of LINK Button and MODE Button.....	11
7.1.2 LED Indication .....	11
7.1.3 Keyboard Hotkeys .....	12
7.2 OSD Menu .....	12
7.3 Receiver Configuration .....	14
7.3.1 Advanced settings .....	14
7.3.2 Console Collaboration Function.....	15
7.3.3 Video Wall Function.....	17
7.4 Transmitter Configuration .....	17
Chapter 8 Web-based Management Interface .....	19
8.1 Interface Introduction .....	19
8.2 [System] Tab.....	19
8.3 [Video Wall] Tab.....	22
8.3.1 [Basic Setup] page of [Video Wall] Tab .....	22
8.3.2 Example of Building up a 2 x 2 Video Wall .....	23
8.3.3 Example of Removing an existing Video Wall layout.....	24
8.3.4 [Advanced Setup] page of [Video Wall] Tab .....	25
8.4 [Network] Tab.....	27
8.5 [Functions] Tab .....	27
Chapter 9 Technical Support.....	30
Chapter 10 FCC/CE Statements .....	31

# Chapter 1 Introduction

**VHX131L/VHX231L** is an IP-based Matrix KVM over IP extender which allows users to remotely access HDMI, USB, Analog audio, RS-232 and IR signals at local sites over a Gigabit Local Area Network. This Virtual Matrix KVM extender includes two main units, the transmitter unit, and the receiver unit. Those two units have their unique IP addresses so that they can transmit and receive KVM signals over the Gigabit LAN. Multiple transmitters and receivers connected to the Gigabit LAN can realize a virtual cross point IP matrix switching. The maximum number of single-display TX units in the LAN is 100 (e.g. 100 single-display TX units or 50 dual-display TX units).

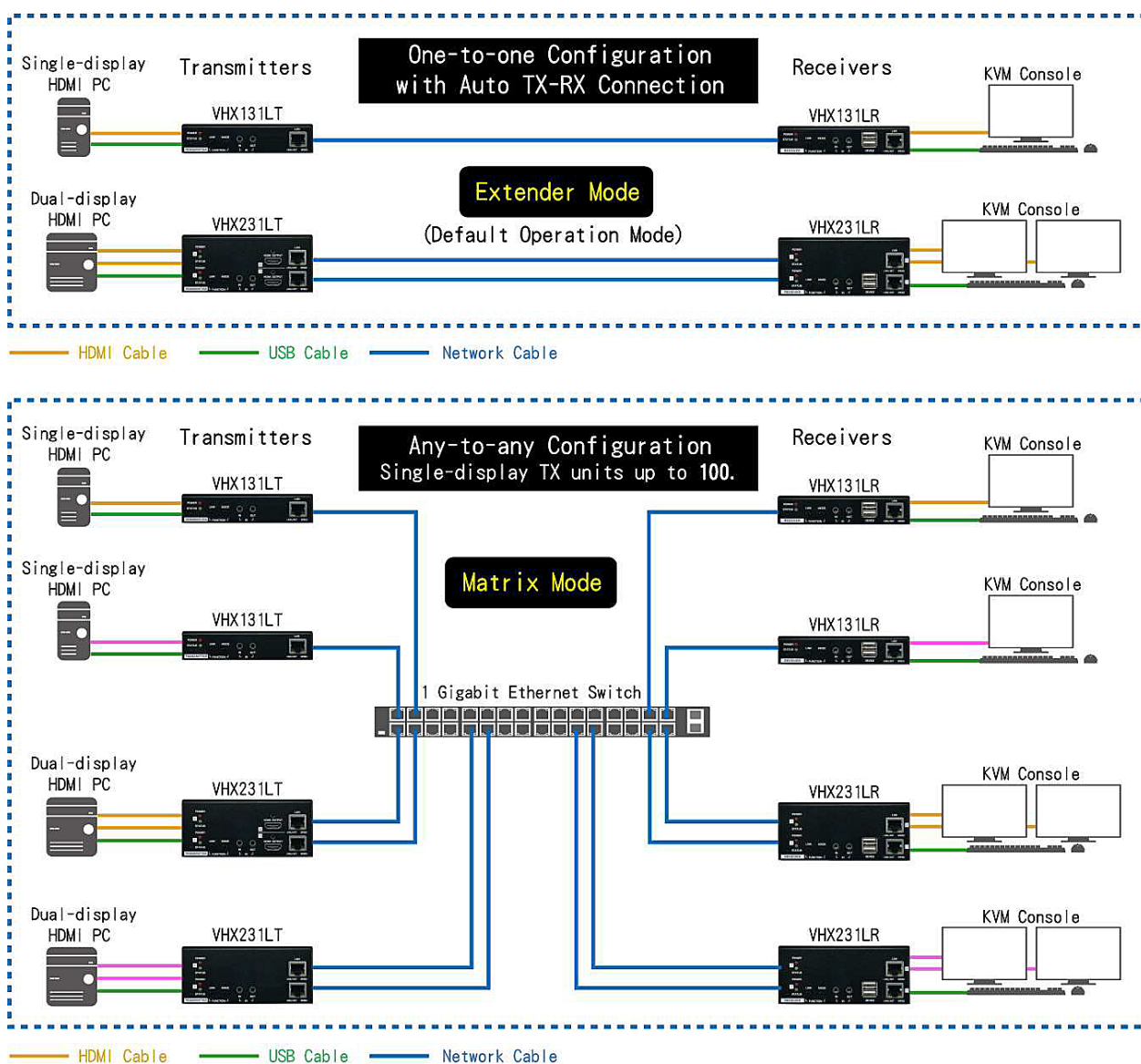


Figure 1-1 VHX131L/VHX231L Extenders One-to-one Configuration and Any-to-any Configuration

## Chapter 2 Features

- Less-than-a-second switching among target PCs
- Any-to-Any matrix configuration
- IP-based technology eliminates distance limitation between TX and RX units
- Value-added functions including video wall and console collaboration
- Multicast 1:1 pixel mapping with instant video transmission
- USB 2.0 specification enables most USB 2.0 compliant devices

## Chapter 3 Package Contents

The packaging lists of VHX131L / VHX231L KVM extenders are shown in the following tables.

*Table 3-1 VHX131L/VHX231L Package Contents*

<b>VHX131L Single-display HDMI KVM Extender</b>	
VHX131LT (Single-display Transmitter)	VHX131LR (Single-display Receiver)
Transmitter unit x 1	Receiver unit x 1
Power adapter x 1	Power adapter x 1
User's manual x 1	User's manual x 1
RS-232 DB9 female to RJ-12 male cable x 1	RS-232 DB9 male to RJ-12 male cable x 1
USB Type-A male to Type-B male cable x 1	* Optional IR Remote Control Unit Pack (Including: Wired IR Emitter/Receiver)
Audio/Mic. male-to-male cable x 1	
HDMI male-to-male cable x 1	
* Optional IR Remote Control Unit Pack (Including: Wired IR Emitter/Receiver)	

<b>VHX231L Dual-display HDMI KVM Extender</b>	
VHX231LT (Dual-display Transmitter)	VHX231LR (Dual-display Receiver)
Transmitter unit x 1	Receiver unit x 1
Power adapter x 1	Power adapter x 1
User's manual x 1	User's manual x 1
RS-232 DB9 female to RJ-12 male cable x 1	RS-232 DB9 male to RJ-12 male cable x 1
USB Type-A male to Type-B male cable x 1	* Optional IR Remote Control Unit Pack (Including: Wired IR Emitter/Receiver)
Audio/Mic. male-to-male cable x 1	
HDMI male-to-male cable x 2	
* Optional IR Remote Control Unit Pack (Including: Wired IR Emitter/Receiver)	

## Chapter 4 Specification

### 4.1 VHX131LT/VHX131LR Specification

Table 4-1 VHX131LT / VHX131LR Specification

	VHX131LT	VHX131LR
<b>VHX131L Extender</b>	1 x HDMI Input	1 x HDMI Output
	1 x USB Type-B Connector	2 x USB Type-A (Keyboard/Mouse) Connector
	1 x IR Input + 1 x IR Output	2 x USB Type-A (Device) Connector
	2 x 3.5mm Audio Jack	1 x IR Input + 1 x IR Output
	2 x Push Button (LINK/MODE)	2 x 3.5mm Audio Jack
	1 x RJ-12 RS-232 Connector (Female)	2 x Push Button (LINK/MODE)
	1 x RJ-45 LAN Connector	1 x RJ-12 RS-232 Connector (Female)
	1 x 2.1mm Power Jack	1 x RJ-45 LAN Connector
	2 x LED Indicators (POWER/STATUS)	1 x 2.1mm Power Jack
		2 x LED Indicators (POWER/STATUS)
	<b>USB</b>	Supports USB 2.0 Devices (Low Speed/Full Speed/High Speed)
<b>Max. Video Resolution</b>	3840 x 2160@30Hz	
<b>Audio</b>	Analog Line In/Out 2 channel 16bit 48KHz 1 Vrms	
<b>Network</b>	1 Gbps Ethernet network for Matrix Switching Access	
<b>Certificates</b>	CE, FCC, BIS	

\*This specification is subject to change without prior notice.

### 4.2 VHX231LT/VHX231LR Specification

Table 4-2 VHX231LT / VHX231LR Specification

	VHX231LT	VHX231LR
<b>VHX231L Extender</b>	2 x HDMI Input + 2 HDMI Output	2 x HDMI Output
	1 x USB Type-B Connector	2 x USB Type-A (Keyboard/Mouse) Connector
	1 x IR Input + 1 x IR Output	2 x USB Type-A (Device)
	2 x 3.5mm Audio Jack	1 x IR Input + 1 x IR Output
	2 x Push Button (LINK/MODE)	2 x 3.5mm Audio Jack
	1 x RJ-12 RS-232 Connector (Female)	2 x Push Button (LINK/MODE)
	2 x RJ-45 LAN Connector	1 x RJ-12 RS-232 Connector (Female)
	1 x 2.1mm Power Jack	2 x RJ-45 LAN Connector
	4 x LED Indicators (POWER/STATUS)	1 x 2.1mm Power Jack
		4 x LED Indicators (POWER/STATUS)
<b>USB</b>	Supports USB 2.0 Devices (Low Speed/Full Speed/High Speed)	
<b>Max. Video Resolution</b>	3840 x 2160@30Hz	
<b>Audio</b>	Analog Line In/Out 2 channel 16bit 48KHz 1 Vrms	
<b>Network</b>	1 Gbps Ethernet network for Matrix Switching Access	
<b>Certificates</b>	CE, FCC, BIS	

\*This specification is subject to change without prior notice.

## Chapter 5 Product Overview

### 5.1 VHX131LT/VHX131LR

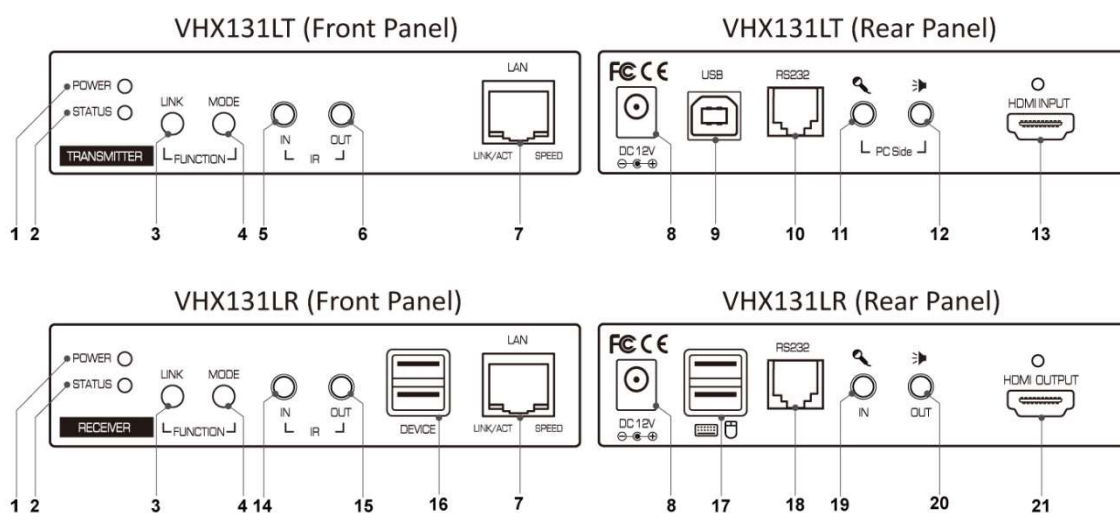


Figure 5-1 VHX131LT / VHX131LR Panels

Table 5-1 VHX131L Description

No.	Item	Description
1	POWER indicator	Lights when the unit power is on.
2	STATUS indicator	Lights when the video source for transmitter/receiver is available. Flashes when the video source for transmitter/receiver is unavailable.
3	LINK button	Press to enable/disable the connection between a transmitter and a receiver.
4	MODE button	After using LINK button to disconnect TX/RX, use this button to set Jumbo Frames.
5	IR input jack (Group A)	Connect to an IR receiver (TX controls RX).
6	IR output jack (Group B)	Connect to an IR emitter (RX controls TX).
7	LAN port	Connect to a LAN port of a Gigabit Ethernet Switch.
8	Power jack	Connect to the power adapter.
9	USB Type-B connector	Connect to the host PC.
10	RS-232 connector	Connect to the RS-232 port of the PC.
11	Mic. output jack	Connect to the mic. input jack of the PC.
12	Audio input jack	Connect to the audio output jack of the PC.
13	HDMI input connector	Connect to the HDMI output of the PC.
14	IR input jack (Group B)	Connect to an IR receiver (RX controls TX).
15	IR output jack (Group A)	Connect to an IR emitter (TX controls RX).
16	USB Type-A connector	Connect to USB peripherals.
17	USB Type-A connector	Connect to a set of USB keyboard and mouse.
18	RS-232 connector	Connect to a console RS-232 device.
19	Mic. input jack	Connect to a console microphone.
20	Audio output jack	Connect to a console speaker.
21	HDMI output	Connect to a console HDMI monitor.

## 5.2 VHX231LT/VHX231LR

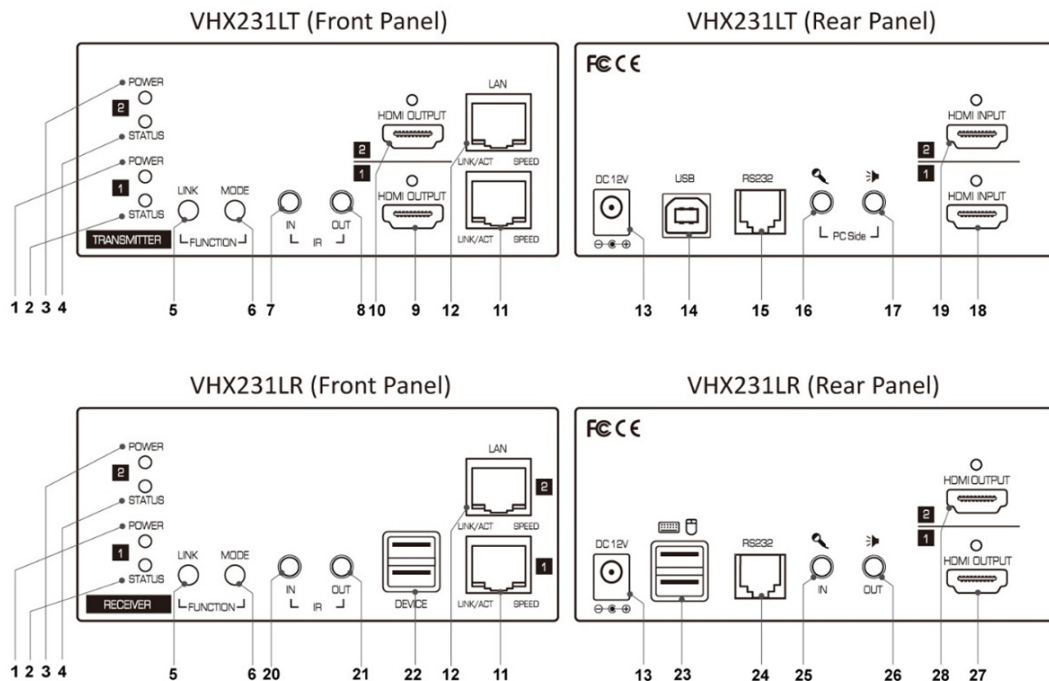


Figure 5-2 VHX231LT / VHX231LR Panels

Table 5-2 VHX231L Description

No.	Item	Description
1	CH1 POWER indicator	Lights when the transmitter/receiver CH1 power is on.
2	CH1 STATUS indicator	Lights when the video source for transmitter/receiver CH1 is available. Flashes when the video source for transmitter/receiver CH1 is unavailable.
3	CH2 POWER indicator	Lights when the transmitter/receiver CH2 power is on.
4	CH2 STATUS indicator	Lights when the video source for transmitter/receiver CH2 is available. Flashes when the video source for transmitter/receiver CH2 is unavailable.
5	LINK button	Press to enable/disable the connection between a transmitter and a receiver.
6	MODE button	After using LINK button to disconnect TX/RX, use this button to set Jumbo Frames.
7	IR input jack (Group A)	Connect to an IR receiver (TX controls RX).
8	IR output jack (Group B)	Connect to an IR emitter (RX controls TX).
9	CH1 HDMI Output (Loop-back)	Connect to a primary HDMI monitor at the local PC site.
10	CH2 HDMI Output (Loop-back)	Connect to a secondary HDMI monitor at the local PC site.
11	CH1 LAN port	Connect to a LAN port of a Gigabit Ethernet Switch.
12	CH2 LAN port	Connect to a LAN port of a Gigabit Ethernet Switch.
13	Power jack	Connect to the power adapter.
14	USB Type-B connector	Connect to the host PC.
15	RS-232 connector	Connect to the RS-232 port of the PC.
16	Mic. output jack	Connect to the mic. input jack of the PC.
17	Audio input jack	Connect to the audio output jack of the PC.
18	CH1 HDMI input	Connect to the primary HDMI output of the PC.
19	CH2 HDMI input	Connect to the secondary HDMI output of the PC.
20	IR input jack (Group B)	Connect to an IR receiver (RX controls TX).
21	IR output jack (Group A)	Connect to an IR emitter (TX controls RX).
22	USB Type-A connector	Connect to USB peripherals.
23	USB Type-A connector	Connect to a set of USB keyboard and mouse.
24	RS-232 connector	Connect to a console RS-232 device.
25	Mic. input jack	Connect to a console microphone.
26	Audio output jack	Connect to a console speaker.
27	CH1 HDMI output	Connect to the console primary HDMI monitor on which the OSD menu is displayed.
28	CH2 HDMI output	Connect to the console secondary HDMI monitor.

## Chapter 6 Connection Diagram

The diagrams illustrated here are examples of the Virtual Matrix KVM over IP system, the actual applications may vary. All illustrated computers, network switch, accessories and monitors are not included in the package, it is for reference only. Make sure all the devices and peripherals are connected appropriately before using the system.

The Virtual Matrix KVM over IP system supports TX/RX extender unit connection directly or via a Gigabit Ethernet Switch according to your requirement.

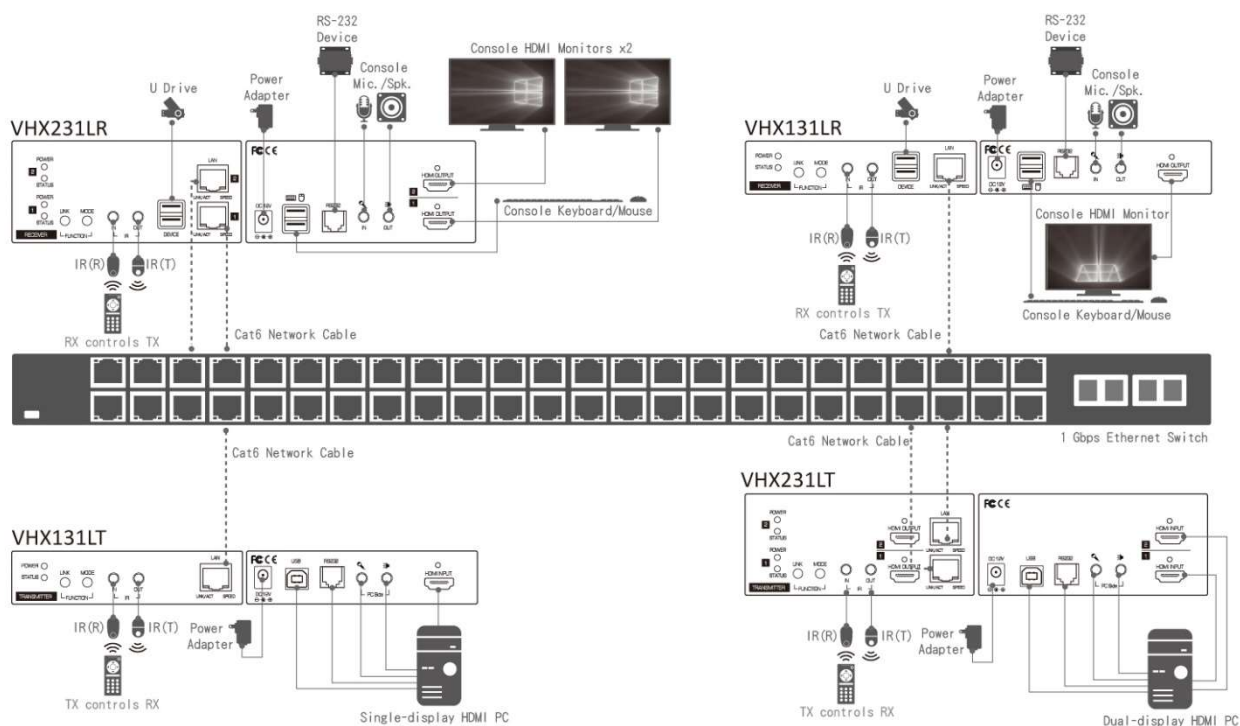


Figure 6-1 Virtual Matrix KVM over IP System Connection Diagram

### 6.1 Before Connection

Before you configure the Virtual Matrix KVM over IP System, you should have these items on the checklist ready:

1. Plan the layout path and deploy the UTP cable for extension.
2. Plan the path through which the CAT5e/CAT6 UTP cable (or higher category network cable) will be deployed across the distance between the Transmitters and the Receivers. You should choose the layout path not only based on shortest possible length consideration, but also on least electromagnetic interference.

#### Notes

Using good quality CAT5e/CAT6 cable can produce better video outcome with longer distance span.

An ideal location is near the power outlets where you locate the extenders.

### 6.2 System Deployment with Direct Connection

Users can extend the PC KVM signals using a point-to-point connection simply via a CAT5e/CAT6 cable. FIG. 6-2 and FIG. 6-3 respectively show the direct connections of single-display extender models and dual-display extender models.

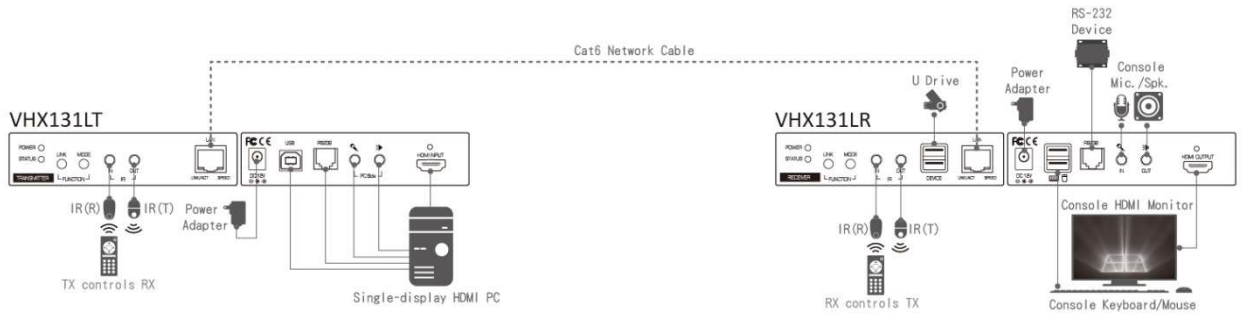


Figure 6-2 Single-display model (VHX131L) Direct Connection

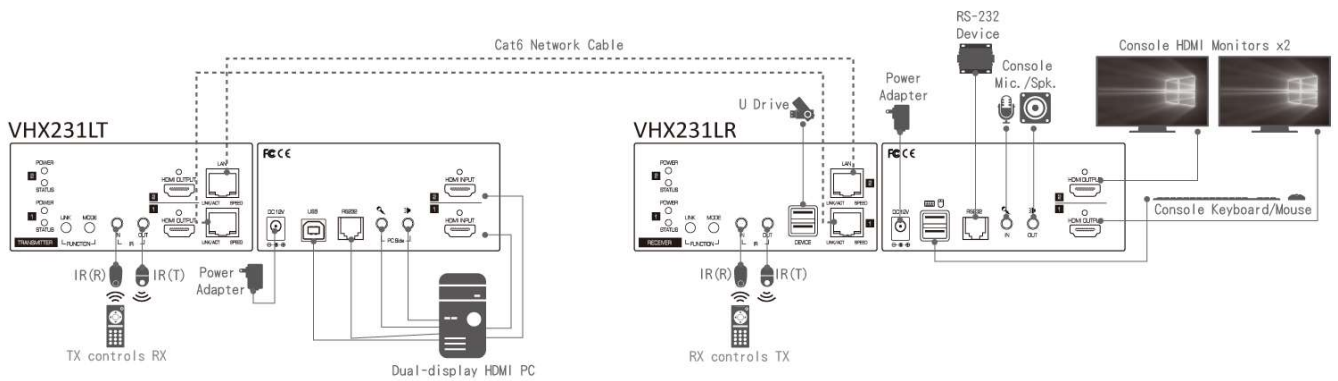
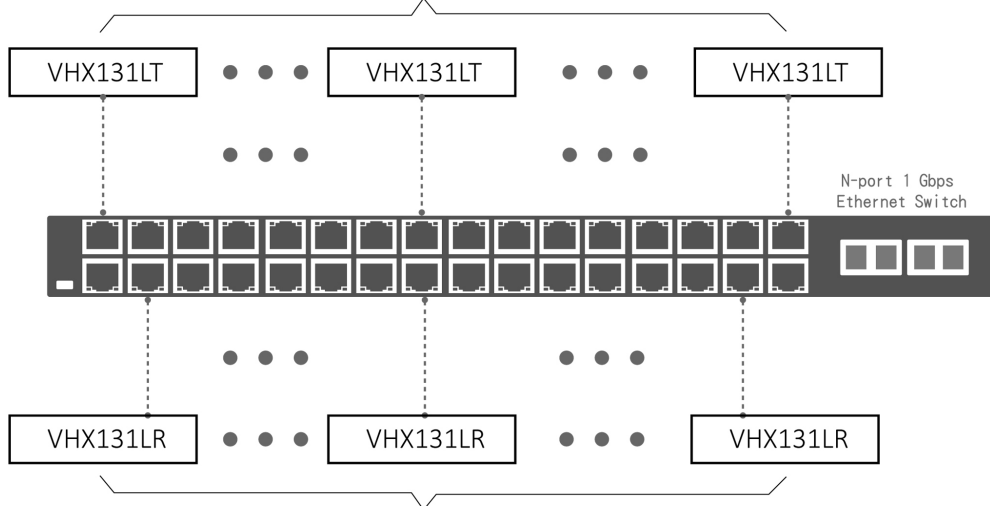


Figure 6-3 Dual-display model (VHX231L) Direct Connection

### 6.3 System Deployment with Network Switch Connection

Based on your requirement, you can also connect a transmitter to multiple receivers with a Gigabit Ethernet Switch. A Gigabit Ethernet Switch is necessary if your application includes more than one TX unit and one RX unit. The Virtual Matrix KVM over IP system allows deploying up to 100 single-display transmitter units (or 50 dual-display transmitter units) in a 1Gbps LAN.

100 Single-display/50 Dual-display Transmitter Units (100 video-channels in total)



As the maximum number of single-display transmitter units VHX131LT deployed is 100, the maximum number of single-display receiver units deployed VHX131LR will be 65435.

Figure 6-4 System Deployment with Network Switch Connection

Some key requirements of the Gigabit Switch need to be considered as follows:

When deploying these TX/RX units, a Gigabit-class Ethernet Switch is required, to guarantee good video streaming quality with its sufficient bandwidth. To ensure better quality of signal transmission, a reputable switch brand is highly recommended.

Some of featured functions of the Gigabit Ethernet Switch are required, for example, **IGMP V2 Snooping**, **Multicast Filtering**, **Jumbo Frame**, **IGMP Querier**, and **IGMP Fast Leave** are also strongly recommended. Especially when multiple TX units are connected to the same LAN without supporting **IGMP Querier** by the Ethernet Switch, the Extender System may work incorrectly. Following screenshots are examples of those configurations, for more setting details, please refer to the instruction manual of your Ethernet Switch.

**[IGMP Snooping] function**

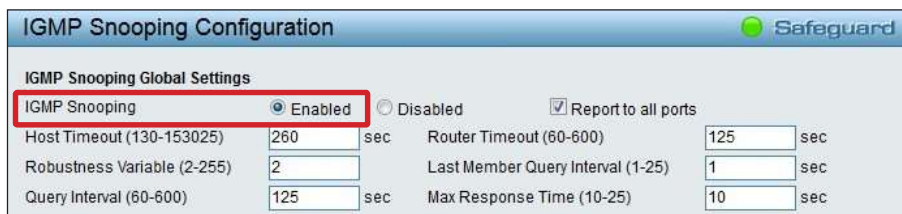


Figure 6-5 IGMP Snooping

**[Jumbo Frame] function**



Figure 6-6 Jumbo Frame

**[Multicast Filtering] function**



Figure 6-7 Multicast Filtering

Make sure you have enough available bandwidth between switches if the LAN you deployed is a cascading architecture, otherwise, the video streaming quality may become lowered.

## Chapter 7 Operation

1. Power on the transmitters, receivers and all the connected devices.
2. Long press (for at least 3 seconds) the **LINK** button on the front panels of transmitters or receivers to make connections between TX and RX units. (**\*Note:** This button will not function if the TX/RX device hasn't been previously linked to another RX/TX device with the RX OSD menu.)

For more details, refer to the section description of *7.1 Front Panel Buttons and LED Indication*.

Note: This Matrix KVM over IP system allows multiple receiver users to access single computer connected via a transmitter; however, the access contention of mouse/keyboard may happen if multiple users are trying to access the same computer simultaneously. To avoid access contention, the system only grants the access right of keyboard/mouse to the first receiver user who accesses the computer first. If other receiver users want to access the keyboard/mouse, a time-out time will start from the moment which the first receiver user stopped operating his keyboard/mouse. As the time-out time elapses, the next receiver user who first operates his keyboard/mouse will gain the access right of the computer and the previous (first) receiver user will lose the same at the same time. Under this rule, there will be only one receiver user allowed to access the computer at any moment with his keyboard/mouse.

### 7.1 Front Panel Buttons and LED Indication

These front panel buttons provide a simple and intuitive operation for users. It is easy to configure the transmitter/receiver units by pressing the buttons directly.

#### 7.1.1 Functions of LINK Button and MODE Button

1. **Enable/Disable Device Connection:** Long press the **LINK** button to toggle TX/RX connection/disconnection.
2. **Restore Factory Default Settings:** Unplug the power jack. Press and hold the **LINK** button then plug in the power jack again to power the unit on. The red **POWER** LED and green **STATUS** LED will first light up then extinguish at the same time. Next, red **POWER** LED will start blinking. Keep the **LINK** button pressed until green **STATUS** LED and red **POWER** LED turn constantly ON. Next, unplug and plug in the power jack again. The transmitter/receiver will restore factory default settings.
3. **Access USB devices:** Long press the **MODE** button on the receiver front panel and then connect the USB device. When multiple receivers are connected to the same transmitter, a user can press the **MODE** button and then insert his USB device to prioritize the USB device detection of the computer for this USB device.
4. **Set up Jumbo Frames:** Long press the **LINK** button of the transmitter or receiver to disconnect network connection. Next, long press the **MODE** button and the **STATUS** LED lights up steady which represents the Jumbo Frame is set as 8000. Or short press the **MODE** button and the **STATUS** LED flashes, which represents the Jumbo Frame is set as 1500. Note that the Jumbo Frame settings of the connected transmitter and receiver must be the same.

#### 7.1.2 LED Indication

1. LED Indications after Power is ON.

Table 7-1 LED Indication

Unit Operation	Power Jack Inserted	Starting up	Start-up Completed	Not Connected Yet	Connection Completed
Red LED (POWER)	OFF	Blinking	Constantly ON	Constantly ON	Constantly ON
Green LED (STATUS)	OFF	OFF	OFF	Blinking	Constantly ON

2. Ethernet LAN Port LED Indications.

As VHX131LT/VHX231LT and VHX131LR/VHX231LR are connected to the LAN successfully, the Yellow LED of the unit Ethernet LAN Port is constantly ON and the Green LED is blinking.

### 7.1.3 Keyboard Hotkeys

To select different PCs connected with transmitters from the receiver console, multiple keyboard hotkeys are provided for use. Each keyboard hotkey includes at least three keystrokes.

Keyboard Hotkey = < **Scroll Lock**, **Scroll Lock** (the first two same keystrokes are the hotkey preceding sequence), **Command key(s)**>

For more keyboard hotkeys and their corresponding functional commands, refer to the below table.

In addition, you can also define a preferred hotkey preceding sequence other than the **Scroll Lock** key if it's been used as the hotkey by other programs.

User-definable keys as hotkey preceding sequence: **Scroll Lock** key, **Num Lock** key, **Caps Lock** key, **Left Alt** key or **Right Alt** key.

Table 7-2 Keyboard Hotkey Table

Command Description	Keyboard Hotkey
Switch to previous listed transmitter in the OSD menu.	<Scroll Lock, Scroll Lock, Up>
Switch to next listed transmitter in the OSD menu.	<Scroll Lock, Scroll Lock, Down>
Copy EDID to the selected transmitter.	<Scroll Lock, Scroll Lock, M>
USB connection (device port) at the front panel of the receiver. Switch among USB devices connected to different receivers.	<Scroll Lock, Scroll Lock, U>
Transmitter Direct Switching Directly switch to connect the current RX unit to a desired TX unit in any preset numbers. (*Preset numbers must be defined in Advanced Setting at the receiver OSD menu.)	<Scroll Lock, Scroll Lock, Numbers, Enter>
Receiver Output Resolution Setup Select the output resolution: <b>F1</b> (Pass-through): Default Setting <b>F2</b> (Fixed 1920 x 1200) <b>F3</b> (Fixed 1920 x 1080)	<Scroll Lock, Scroll Lock, F1/F2/F3>
Resume the connection with the previously "connected" transmitter.	<Scroll Lock, Scroll Lock, Backspace>

\*Note: For <Scroll Lock, Scroll Lock, U> hotkey, several USB devices may be plugged in different receiver consoles at the same time if the system is operated in matrix mode. You may use this keyboard hotkey to request the highest USB device detection priority by the PC connected to the TX unit which is being connected to the current RX unit.

## 7.2 OSD Menu

Once you have completed the connection (refer to the chapter of connection diagram), press <Scroll Lock, Scroll Lock, Space> hotkey to bring up the OSD menu from the receiver console. Note: Double press left Ctrl key <Ctrl, Ctrl> to prompt the OSD menu quickly.

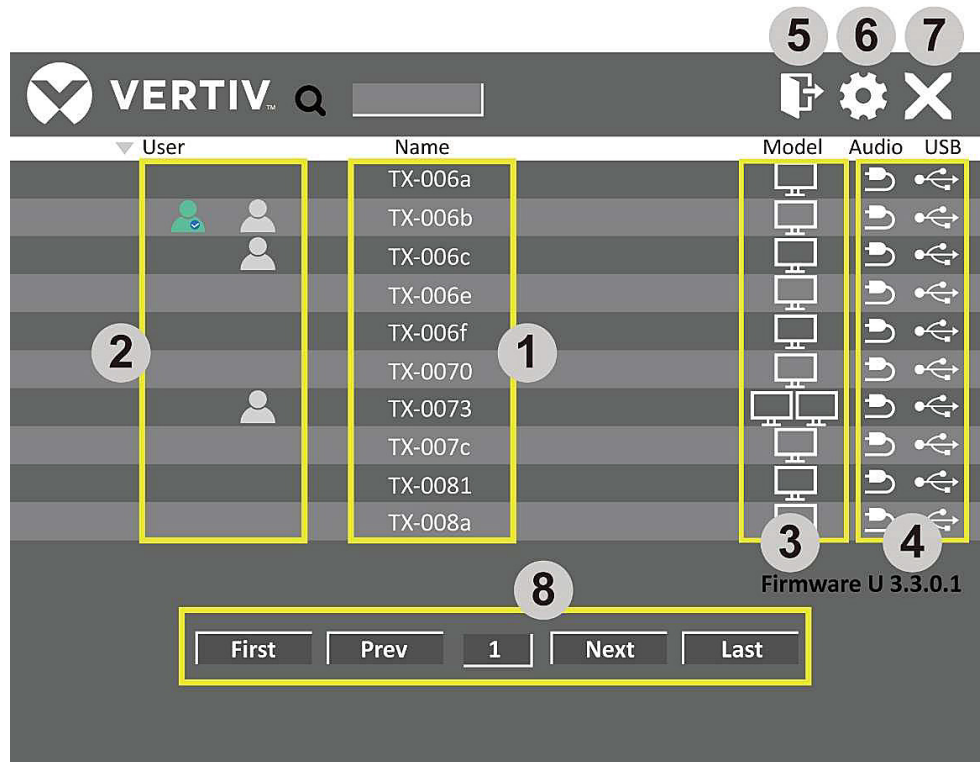


Figure 7-1 Receiver OSD menu transmitter list page

The annotations in Figure 7-1 are as follows:

1. Double click any name of the TX units on the transmitter list you want to connect to. After the connection between selected transmitter and the current receiver has been established, the console monitor will display the video source from the computer connected to the selected transmitter, which allows the user to access the computer at the receiver console. The OSD menu size will be adjusted to an adaptive proportion to the computer desktop after the computer connection is done. (\*Note: When the receiver hasn't connected to any transmitters yet, the OSD menu will be in full-screen size).

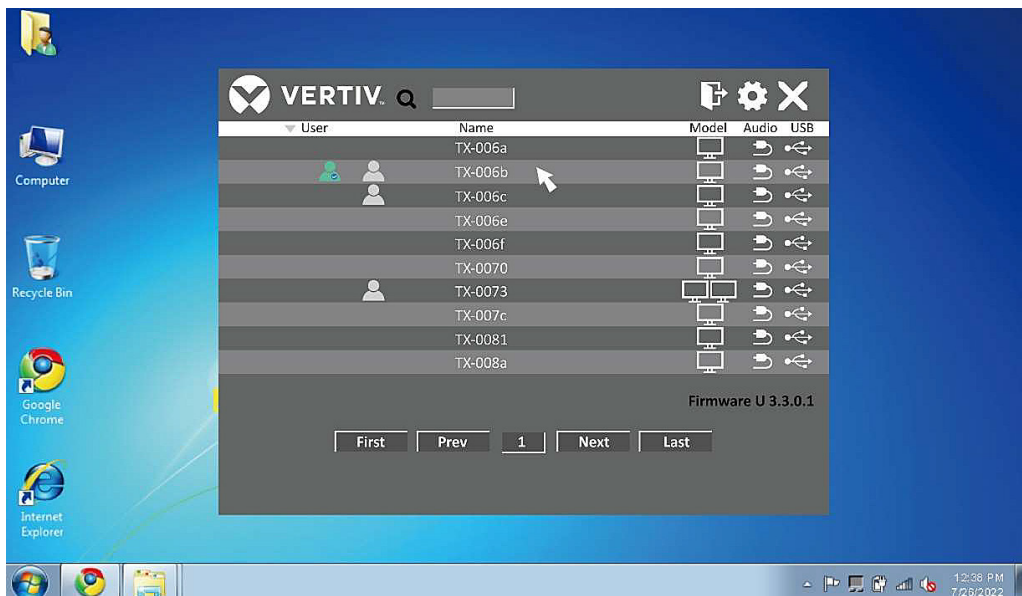


Figure 7-2 OSD Menu in adaptive proportion to computer desktop

2. It shows the status of all receiver users. The yellow user icon represents the user who is using this receiver console. The grey user icons represent other receiver users who are accessing these listed transmitters. Take TX-006b transmitter for example, the OSD menu shows this transmitter is being connected with the current receiver and other receiver(s).
3. Double click on any monitor-icon to configure its corresponding transmitter. Refer to section 7.4 Transmitter Configuration.
4. Click to log out of the OSD menu.
5. Click the gear-icon to configure the receiver. Refer to section 7.3 Receiver Configuration.

6. Click to close the OSD menu.
7. Find all listed transmitter devices page by page.
8. Click to enter Console Collaboration page.
9. The total number of TX and RX units deployed in the LAN. It is updated in real time manner.

## 7.3 Receiver Configuration

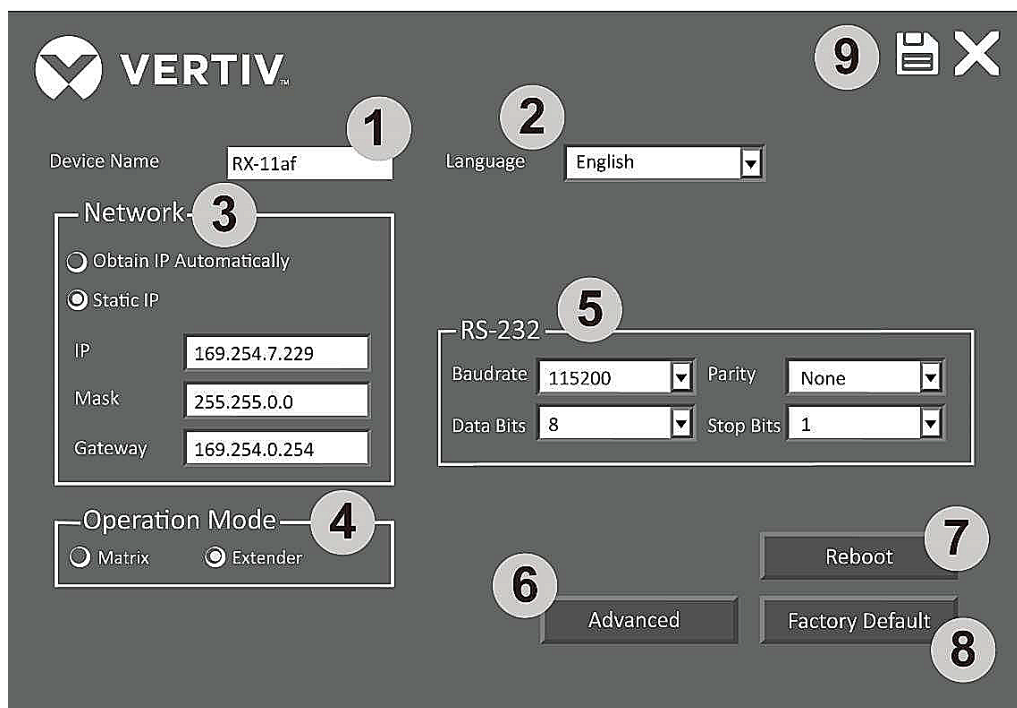


Figure 7-3 Receiver Setting Page

The annotations in Figure 7-3 are as follows:

1. **Device Name:** User can change the name of the receiver for easy recognition.
2. **Language:** Drop down the list to select a preferred language.
3. **Network:** Select **Obtain IP Automatically** (\*receiver unit self-assigned algorithm, not DHCP approach) or set up **Static IP** manually.
4. **Operation Mode:** Select a preferred mode according to your requirement. Make sure that this option matches with the operation mode setting of its connected transmitter. Whenever the Operation Mode options of the two connected TX and RX units are inconsistent, a black screen on the RX monitor will occur.
5. **RS-232:** Setup the serial parameters for the connected RS-232 device. Make sure these parameters must match with the RS-232 settings of the connected transmitter. By default, the system settings are as follows:  
Baud rate: 115200    Data bits: 8    Parity: None    Stop bits: 1
6. **Advanced:** Refer to section 7.3.1 Advanced Settings for more details.
7. **Reboot:** Click to reboot the receiver unit, and then click <OK> button to confirm.
8. **Factory default:** Click to resume the receiver unit to factory default settings, and then click <OK> button to confirm.
9. **Save:** Click to save all settings after you have made any changes to them.

**\*Note: (1) As you need to manually assign IP addresses for transmitter and receiver devices, please always set up TX device before setting up RX device and make sure that their IP addresses are within the same network segment.**  
**(2) New settings will only be applied after the receiver reboots.**

### 7.3.1 Advanced settings

This Matrix KVM over IP system not only supports connecting a preferred transmitter on the OSD menu, but also supports connecting transmitter by directly inputting the keyboard hotkey: <Scroll Lock, Scroll Lock, Number key> and then pressing the <Enter> key. Users can also define their preferred hotkey preceding sequence (Hotkey Prefix) other than the <Scroll Lock> key.

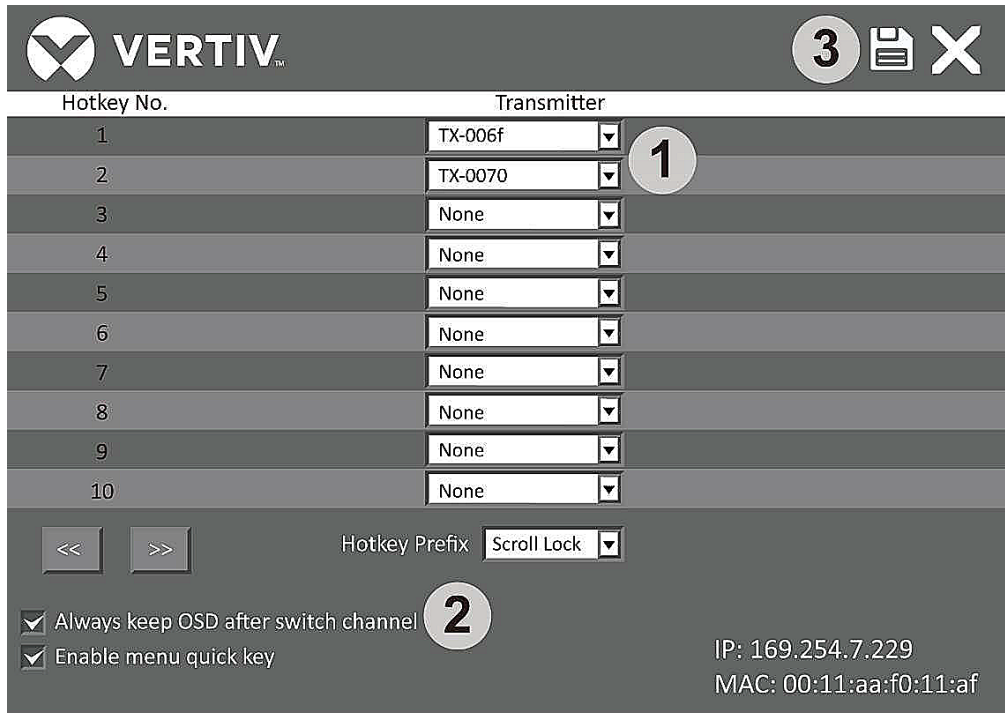


Figure 7-4 Advanced Settings Page

1. Click to drop down the transmitter list and select a desired transmitter to correspond a hotkey number.
2. **Always keep OSD after switch channel:** Check this box to continue displaying the OSD menu on the monitor after switching the receiver connection to another transmitter.
3. **Hotkey Prefix:** Users can change Hotkey Preceding Sequence from this drop-down list, the available options are: **Scroll Lock, Num Lock, Caps Lock, Left Alt** or **Right Alt**.
4. **Save:** Click to save the changed settings.

### 7.3.2 Console Collaboration Function

VHX131LR/VHX231LR Receiver supports Console Collaboration function. With intuitive push/pull operations on the OSD menu, users can share a transmitter signal source which is being connected to a first receiver unit with a second receiver unit. Such that the second receiver unit can also access the computer that is being connected to the transmitter unit, as the first receiver unit does.

The following example shows how to use Console Collaboration function to share a TX source of a RX unit with another RX unit.

- a. Prompt the OSD menus of five RX units (RX-A/RX-B/RX-C/RX-D/RX-E) respectively. Then click the names of 5 TX units (TX-1/TX-2/TX-3/TX-4/TX-5) on the TX lists of the OSD menu respectively to create connections as below:

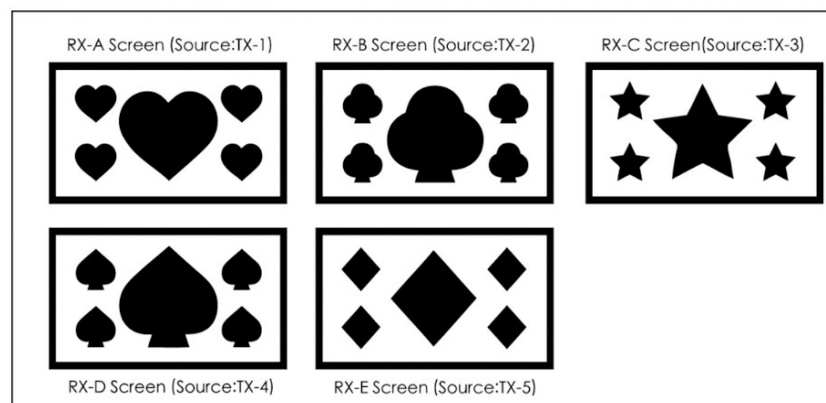


Figure 7-5 5 RX monitors being connected to 5 TX image sources

- b. In the OSD menu of RX-D receiver, click the <Collaborative Console Sharing> icon  to enter the following page:

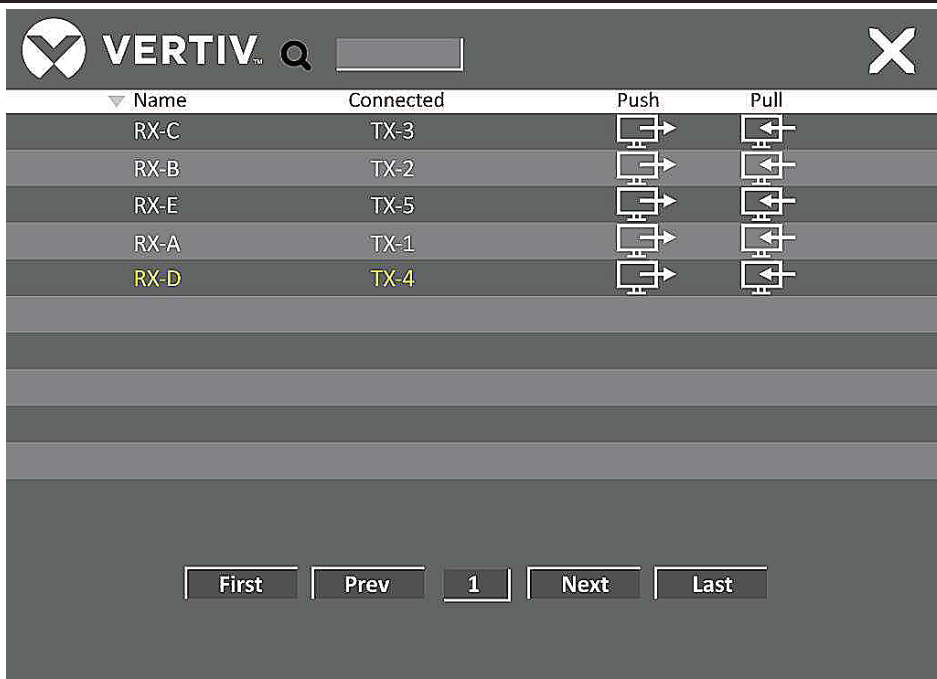


Figure 7-6 Console Collaboration Page

c. User can use the **<Push-sharing>** icon to share the TX-4 source that the RX-D receiver is connecting to with any other available RX target units (e.g. RX-C/RX-B/RX-E/RX-A). Or use the **<Pull-sharing>** icon to connect any sources of TX-3, TX-2, TX-5, TX-1 to the currently used RX-D unit. Such that the RX-D user can also remotely control any desired computers connected to any of those TX sources. The following examples respectively introduce two scenarios of push-sharing and pull-sharing operations.

d. (Push-sharing Operation Scenario)

Click the **<Push-sharing>** icon of RX-E row in RX-D's OSD menu, and the TX-4 source connected to RX-D will be pushed to display on RX-E's monitor. Please note that as RX-D sends out the push-sharing request to RX-E, a confirmation window will prompt to get RX-E user's approval. RX-E user can accept or decline it depending on his working condition.

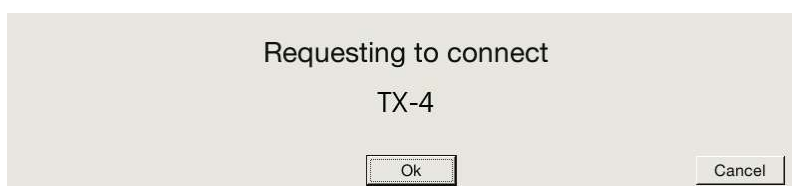


Figure 7-7 Connection Requesting Window

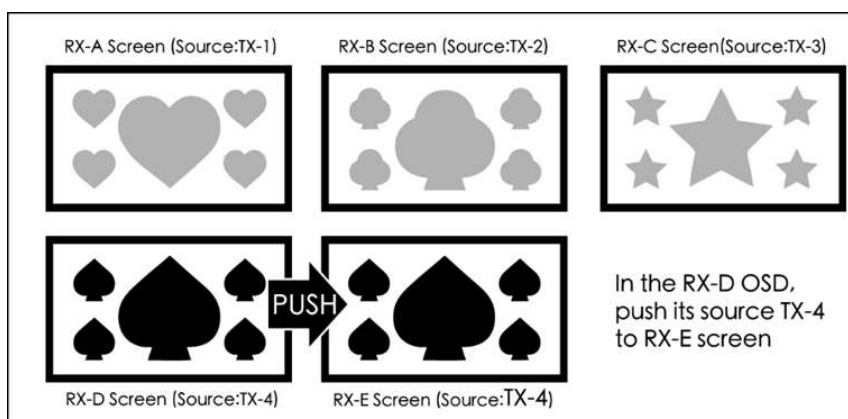



Figure 7-8 Push-sharing Operation Scenario (TX-4 to RX-E)

e. (Pull-sharing Operation Scenario)

Click the <Pull-sharing> icon  of RX-B row in RX-D's OSD menu, and the TX-2 source connected to RX-B will be pulled to display on RX-D's monitor. Also note that, different from push-sharing operation scenario, system will not prompt any request window to request RX-B user's approval.

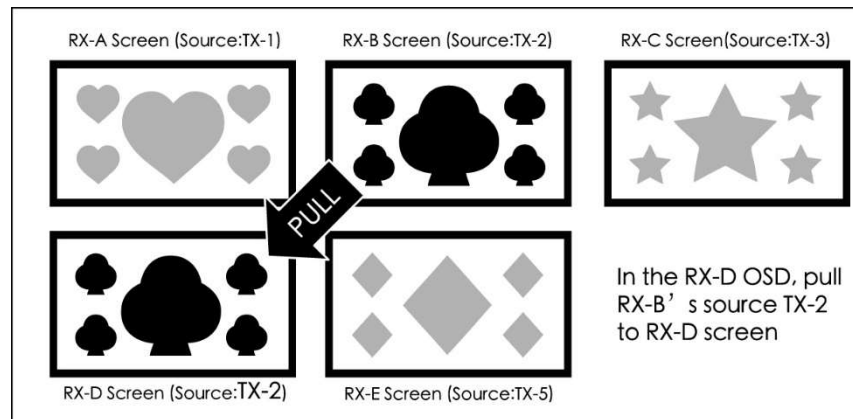
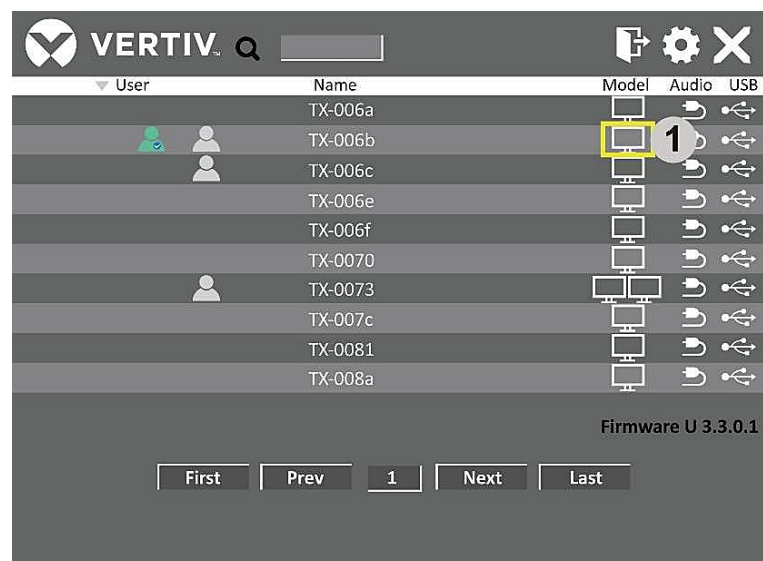


Figure 7-9 Pull-sharing Operation Scenario (TX-2 to RX-D)

### 7.3.3 Video Wall Function

VHX131LR/VHX231LR Receiver supports Video Wall function. Users can group multiple receiver units and assign a Video-wall task to them. After the Video-wall configuration has been set up, a plurality of monitors connected to those Video-wall receiver units can collaborate to show a single video signal from one transmitter unit. Refer to Chapter 8, the [video wall] section of the web-based management interface in this manual, for more details.

## 7.4 Transmitter Configuration



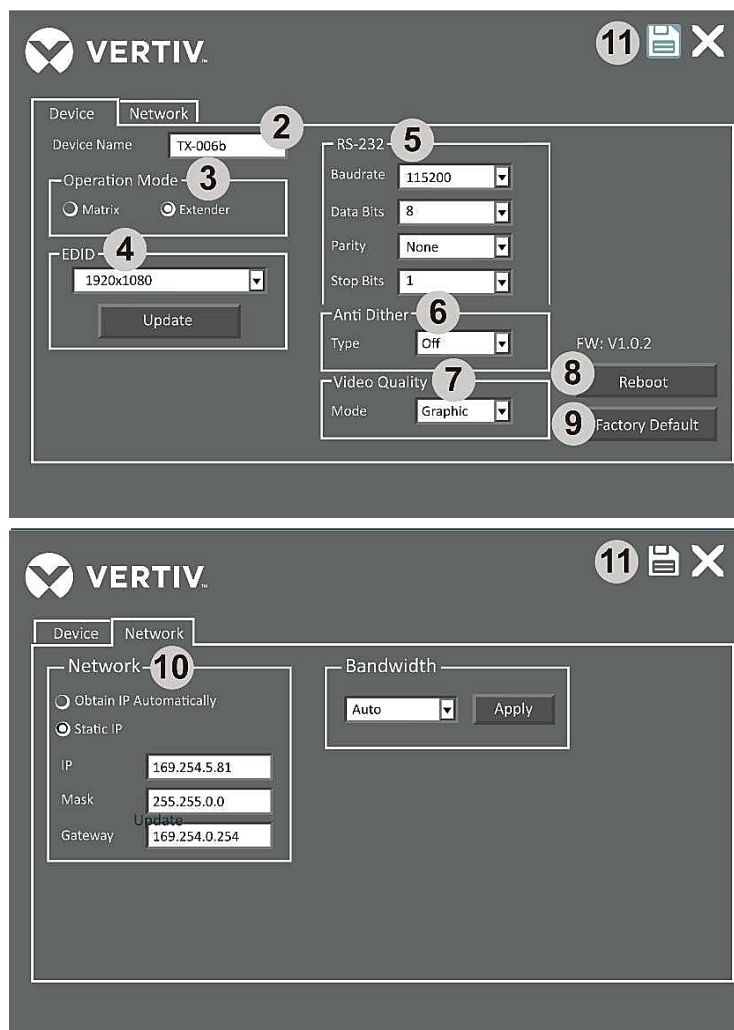


Figure 7-10 Transmitter Setting Page

The annotations in Figure 7-10 are as follows:

1. Double click on the monitor-icon of any desired transmitter to enter its setting page.
2. **Device Name:** User can change the name of the transmitter for easy recognition.
3. **Operation Mode:** Select a preferred mode according to your requirement. Make sure that this option matches with the operation mode setting of its connected receiver. Whenever the Operation Mode options of the two connected TX and RX units are inconsistent, a black screen on the RX monitor will occur.
4. **EDID:** Select the output resolution of the image source, or you can click <Update> button to upload the monitor EDID.
5. **RS-232:** Setup the serial parameters for the connected PC RS-232 port. Make sure these parameters match with the RS-232 settings of the connected receiver. By default, the system settings are as follows:  
Baud rate: 115200    Data bits: 8    Parity: None    Stop bits: 1
6. **Anti Dither:** Apply when the video displayed on the monitor connected to the RX unit is abnormal. (Options: Off/Mode 1/Mode 2).
7. **Video Quality:** Adjust according to user's requirement. (Options: Auto/Graphic/Video).
8. **Reboot:** Click to reboot the transmitter unit, and then click <OK> button to confirm.
9. **Factory default:** Click to resume the transmitter unit to the factory default settings, and then click <OK> button to confirm.
10. **Network:** Select **Obtain IP Automatically** (\*transmitter unit self-assigned algorithm, not DHCP approach) or set up **Static IP** manually.
11. **Save:** Click to save the settings after you have made any change to them.

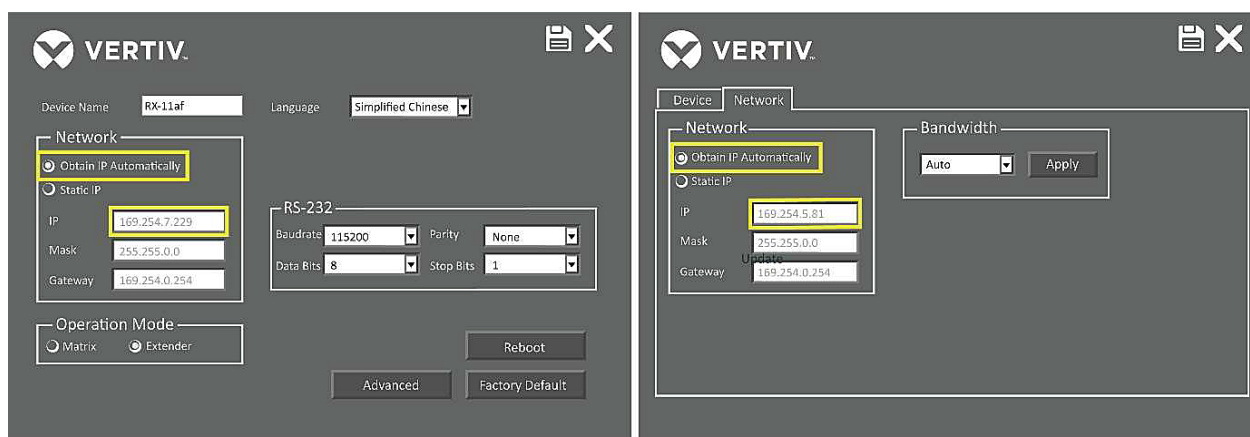
**Note: (1) As you need to manually assign IP addresses for transmitter and receiver devices, please always set up TX device before setting up RX device and make sure that their IP addresses are within the same network segment.**

**(2) New settings will only be applied after the transmitter reboots.**

## Chapter 8 Web-based Management Interface

### 8.1 Interface Introduction

VHX131L/VHX231L Extender includes a web-based management interface for users' device configuration. To access the web-based management interface of an extender unit, please connect a PC with installed web browsers to the same LAN that the extender units are also connected to. Next, you need to collect the IP address information of each TX and RX units. Refer to the previous chapters for the following network setting pages to respectively learn their self-assigned auto IP addresses.



Auto IP address (Receiver Network Setting)

Auto IP address (Transmitter Network Setting)

Figure 8-1 Auto IP addresses Information of Receiver and Transmitter

To enter the web-based management interface of each extender unit, please open a web browser at the PC and directly input its IP address. Taking the above RX unit **RX-11af** as an example, input **169.254.7.229** at the web browser address bar, then press <Enter> key. The web-based management interface menu includes four tabs which are: [System], [Video Wall], [Network], and [Functions].



Figure 8-2 4 Tabs of the Web-based Management Interface Mmenu

### 8.2 [System] Tab

There are four pages in the [System] Tab as the following table shows.

Page	Options	Description
Version Information		Display the information of unit.
* Update Firmware	Update the firmware.	Click <Browse> button to select a firmware file and click <Upload> button to upgrade it. The browser will be reloaded after updating.

		Contact the local distributors for technical support if you have any problems.
<b>Utilities</b>	Factory Default	Restore the factory default settings.
	Reboot	Restart the unit.
	Reset EDID to Default Value	Reset EDID to factory default settings.
	Console API Command	Request technical support from the local distributors to learn the console commands.
<b>* Statistics</b>	Display detailed information of network and video.	

Table 8-1 Tab Introduction of the Web-based Management Interface Menu

### \* [Update Firmware] Page

Keeping your extender firmware with the latest firmware version allows your extender units to operate at best performance with new functions. Following are exemplary steps to update the firmware of the above receiver unit (**RX-11af**):

- (1) Input the IP address, e.g. **169.254.7.229**, at the web browser address bar to enter **RX-11af** receiver’s web-based management interface.
- (2) Check the current unit firmware version (e.g. V1.0.5) before upgrading your extender unit. If you have a newer firmware version than the current one, go on the following steps.

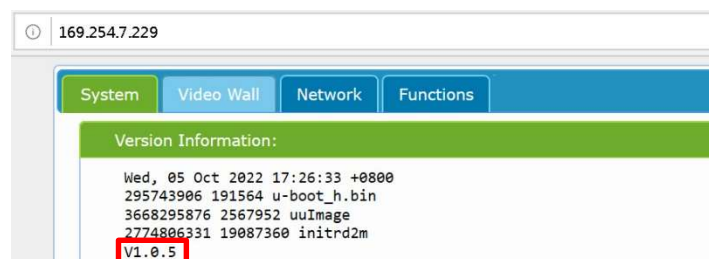


Figure 8-3 [Version Information] Page

- (3) Click on the [Update Firmware] page.
- (4) Click on the <Browse> button to select a target firmware file, and then click the <Upload> button.

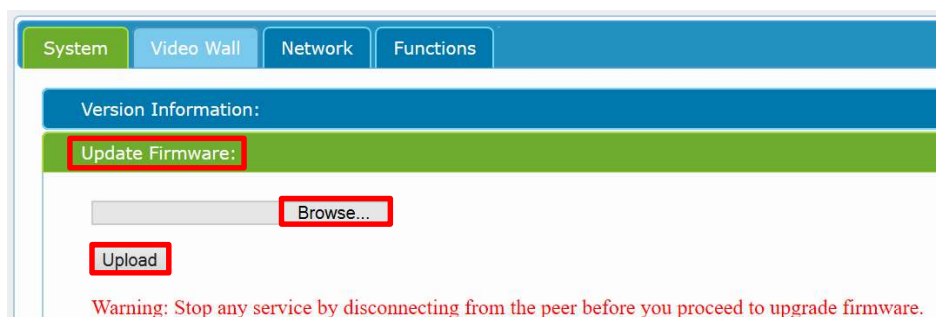


Figure 8-4 [Update Firmware] Page

(5) While the firmware of the extender is being upgraded, the above webpage will display the upgrading progress. In addition, when the firmware of the receiver is being upgraded, the receiver OSD menu will also prompt a warning message: “Upgrading is in progress... DO NOT remove the power”. This is to avoid the user misunderstanding that the unit fails and deciding to remove the power of the receiver unit.

\*Note: As the firmware is being upgraded, the system will also disable user’s keyboard/mouse operation. To avoid any data loss or hardware failure, please wait patiently and DO NOT remove the power of the extender unit during firmware upgrade is in progress.

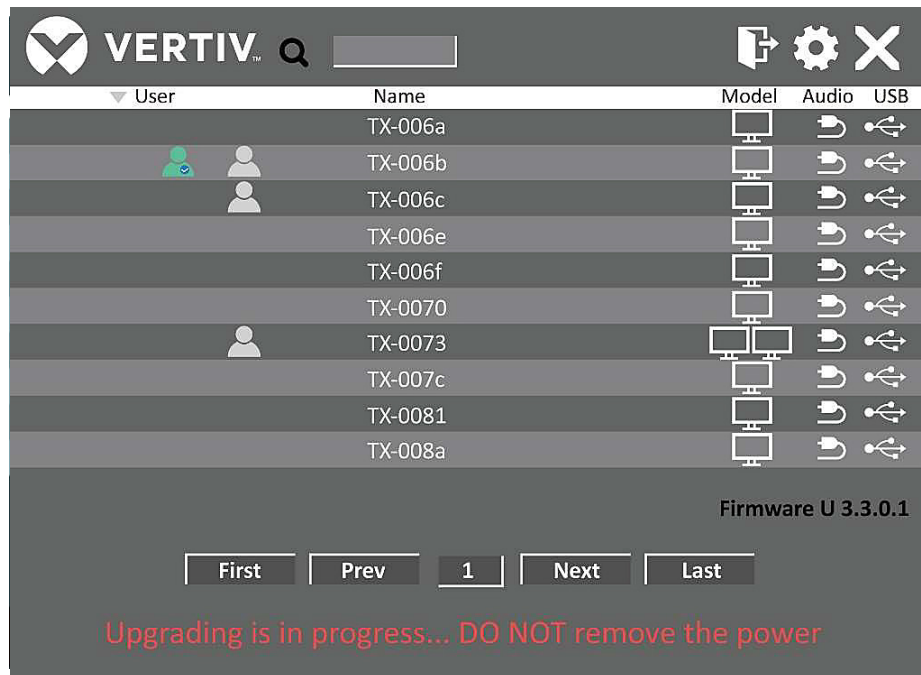


Figure 8-5 Receiver OSD Screenshot during Firmware Upgrade

**\* [Statistics] Page**

This page mainly displays detailed information about Network and Video. When you encounter network and video related issues, please keep the screenshot of this page for troubleshooting.

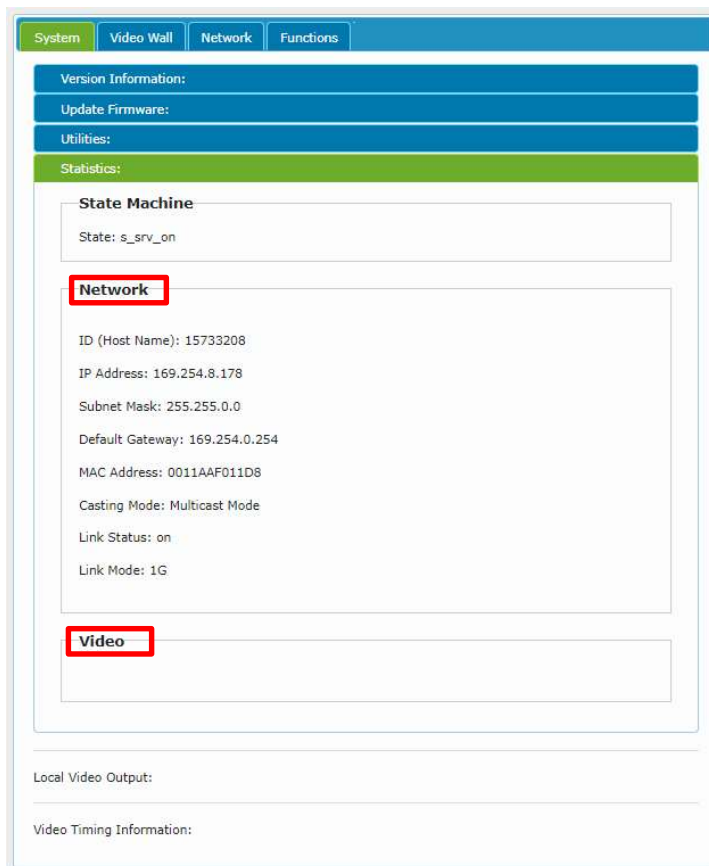


Figure 8-6 [Statistics] Page for Network and Video Detailed Information

## 8.3 [Video Wall] Tab

Note that the video wall settings are only applicable for receivers. However, besides configuring video wall settings in receiver's web-based management interface, you may also configure the receiver video wall settings in any web-based management interfaces of the detected extender units (even in the transmitter units) within the same LAN.

### 8.3.1 [Basic Setup] page of [Video Wall] Tab

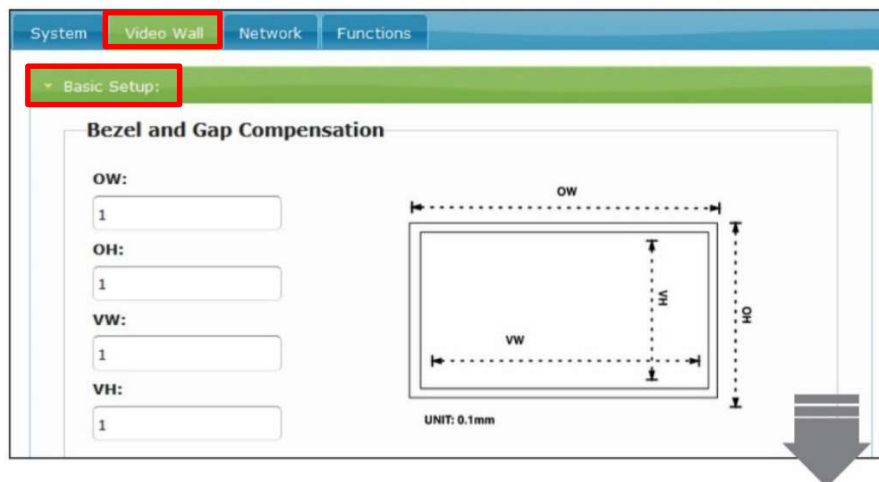


Figure 8-7 [Basic Setup] Page of [Video Wall] Tab

The [Basic Setup] page focuses on the application of symmetric video wall. Note that all the settings here are only applicable to receivers, not transmitters.

Item	Option	Description
<b>Bezel and Gap Compensation</b>	OW	Fill in the width of the monitor outer frame. (e.g. 540, for 540mm)
	OH	Fill in the height of monitor outer frame. (e.g. 320, for 320mm)
	VW	Fill in the width of monitor inner viewable area. (e.g. 525 for 525mm)
	VH	Fill in the height of monitor inner viewable area. (e.g. 305, for 305mm)
<b>Wall Size and Position Layout</b>	Vertical Monitor Count	Set the number of vertical monitors (from 1 to 8).
	Horizontal Monitor Count	Set the number of horizontal monitors (from 1 to 16).
	Row Position	Specify the row position of monitor. The vertical row order number from top to bottom is 0-7.
	Column Position	Specify the column position of monitor. The horizontal column order number from left to right is 0-15.
<b>Preferences</b>	Stretch Type	Select a preferred display type ( <b>Fit In</b> : keep original image size / <b>Stretch Out</b> : Force full-screen image display).
	Clockwise Rotate	Make image clockwise rotation when needed (180°/270°).
<b>Apply to: "All" device(s) in the list</b>		Select the client (receiver) units to apply the settings you have changed. * You may configure the video wall settings to apply on any receivers with the web-based management interface of any detected extender units within the same LAN.
<b>Show OSD</b>		Check/Uncheck to show/hide each receiver's number with OSD on connected monitors.

Table 8-2 Option introduction of [Basic Setup] page of [Video Wall] Tab



Figure 8-8 Display Effect of Checking/Unchecking Show OSD box

### 8.3.2 Example of Building up a 2 x 2 Video Wall

The following example guides you to build up a 2 x 2 Video Wall.

**Step 1)** Connect four RX units to four monitors which are arranged as a Video Wall Matrix.

**Step 2)** Bring up the OSD Menu of each RX units with <ScrLk, ScrLk, Space> keyboard hotkey. Click on the same TX unit name (e.g. TX-006b) from the TX list for each RX unit.

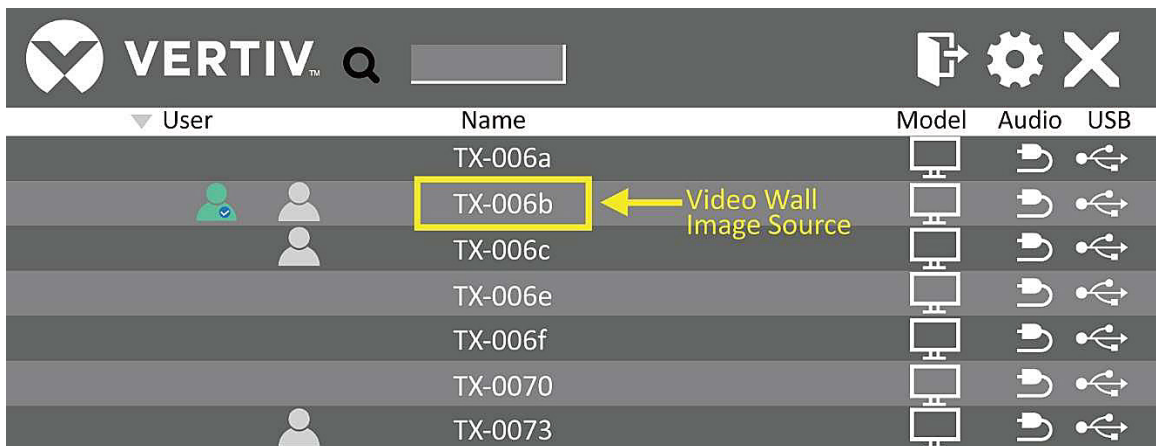
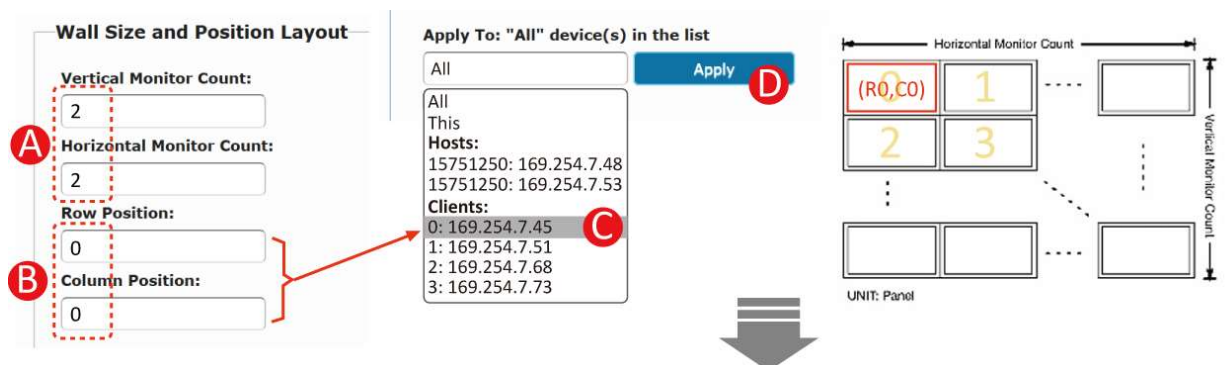


Figure 8-9 TX List Page of the Receiver's OSD Menu

**Step 3)** Designate corresponding positions of each receiver (monitor) to complete the Video Wall layout.

In the [Basic Setup] page of the [Video Wall] Tab, input the Vertical/Horizontal Monitor Count as 2 and 2, respectively. Repeat the same steps (A), (B), (C) and (D) to set up for 4 monitors (from position R0, C0 to position R1, C1). After that, the 4 monitors can collaborate to display a complete image sourced from the TX-006b transmitter unit.



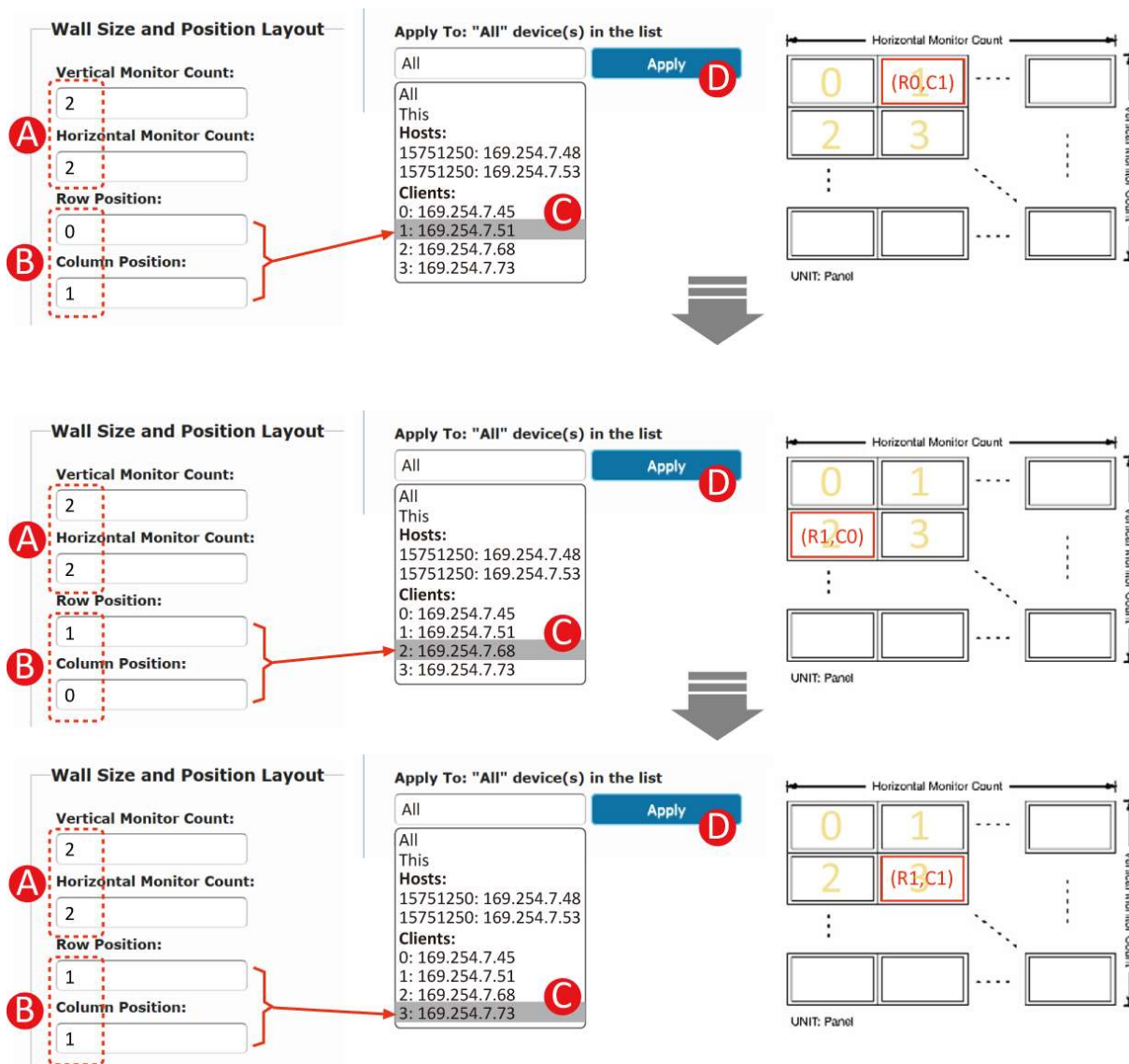


Figure 8-10 Steps to Designate the Receiver/Monitor Positions of a Video Wall

### 8.3.3 Example of Removing an existing Video Wall layout

To remove an existing Video Wall layout, input the default settings: Vertical/Horizontal Monitor Count: 1/1 and Row/Column position 0/0. Select the [All] option, then click on the <Apply> button.

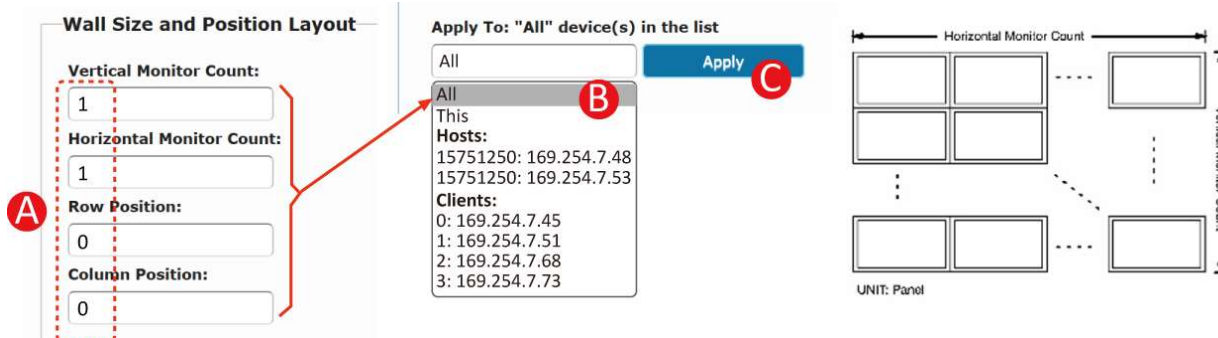


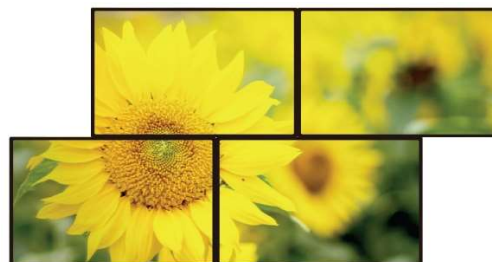
Figure 8-11 Steps to Remove an Existing Video Wall Layout

8.3.4 [Advanced Setup] page of [Video Wall] Tab

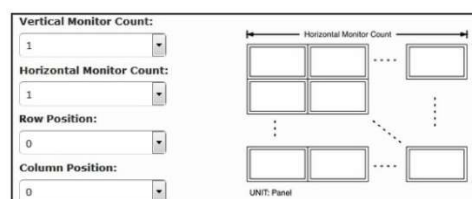



Figure 8-12 [Advanced Setup] Page of [Video Wall] Tab

The [Advanced Setup] page focuses on featured video wall application (refer to the following illustration). User can design an asymmetric video wall according to their requirement. Note that all the settings here are only applicable to receivers, not transmitters.



2. Before setting the [Advanced Setup] page, make sure the video wall layout has been set on the [Basic Setup] page; otherwise, all the options will be unable to select.



2. Click to select the desired receiver unit you wish to configure or click  to select all receiver units. Once a specific desired receiver unit has been selected and clicked, its corresponding button will change to green from blue.



3. Control Options

Item	Options	Description
Show OSD	Check/Uncheck	to show/hide the OSD with each receiver's number on connected monitors.



<b>Control Options</b>	Reset to Basic Setup	You may click to restore if confusing all the video wall settings below. All the settings will restore the settings on the <b>[Basic Setup]</b> page.
	Stretch Type	Select a preferred display type ( <b>Fit In:</b> keep original image size / <b>Stretch Out:</b> Force full-screen image display).
	Clockwise Rotate	Make image clockwise rotation when needed (180°/270°).
	Screen Layout (Row x Column)	Set the layout of video wall. Make sure the layout settings here is same as that in the <b>[Basic Setup]</b> page.
	Row Position	Change the row position of the selected unit.
	Column Position	Change the column position of the selected unit.
	Horizontal Shift	Fine-tune the image position horizontally to left or right. Note that the screen will be displayed in loop horizontally if the image position is adjusted out of edge. It's recommended to enlarge the image from the option of <b>Horizontal/Vertical scale up</b> first before shifting the image position. 
	Vertical Shift	Fine-tune the image position vertically to up or down. Note that the screen will be displayed in loop vertically if the image position is adjusted out of edge. It's recommended to enlarge the image from the option of <b>Horizontal/Vertical scale up</b> first before shifting the image position. 
	Horizontal Scale Up (N pixels/column_count)	Scale up the image from the receiver horizontally.
	Vertical Scale Up (N pixels/row_count)	Scale up the image from the receiver vertically.
Console API Command	Request the <b>UAPI commands</b> guidance from the local distributors.	

Table 8-3 Option introduction of **[Advanced Setup]** page of **[Video Wall]** Tab

## 8.4 [Network] Tab

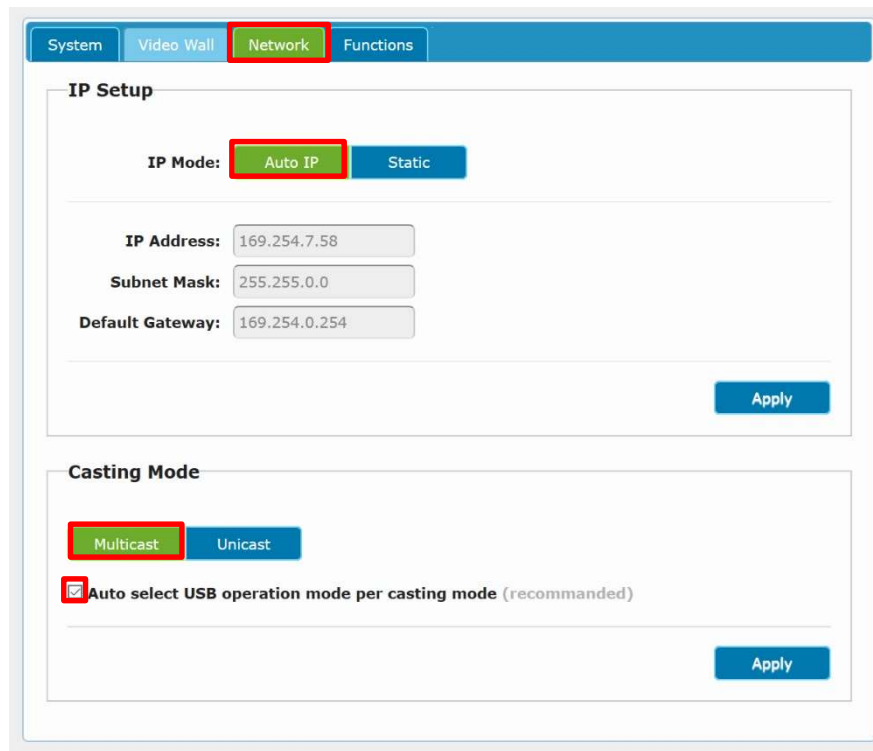


Figure 8-13 [Network] Tab

Item	Options	Description
IP Setup	Auto IP	Assign an IP address by system automatically (recommended).
	Static	Assign an IP address manually. After clicking the <Apply> button, all the settings will be stored even the unit is shut down.
Casting Mode	Multicast	Select this option if your extender's operation mode is set as "Matrix".
	Unicast	Select this option if your extender's operation mode is set as "Extender".
	Auto select USB operation mode per casting mode	Check this box to automatically apply a corresponding USB operation mode according to the selected extender's casting mode. This works the same as checking the "Auto select mode" box in the [USB over IP] item of the [Functions] tab.

Table 8-4 Option Introduction of [Network] Tab

## 8.5 [Functions] Tab

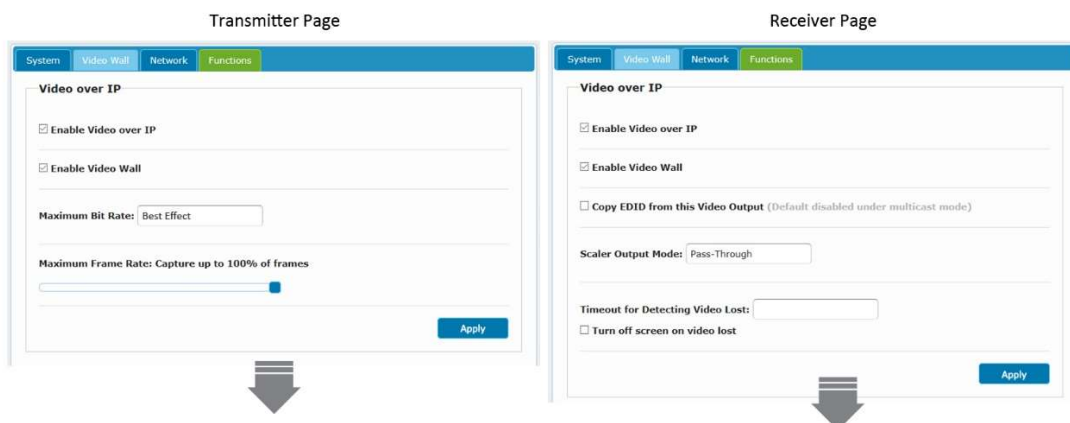
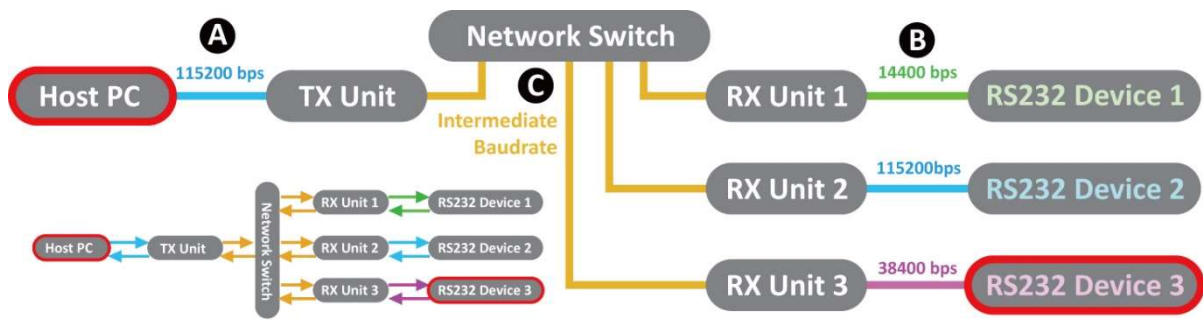


Figure 8-14 [Functions] Tab

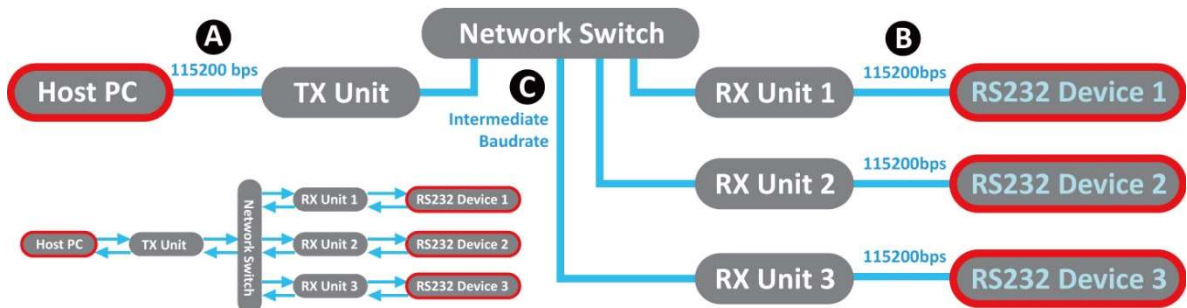
Item	Options	Description
<b>Video over IP</b>	Enable Video over IP	Check/uncheck this box to enable/disable video transmission over IP.
	Enable Video Wall	Check/uncheck this box to show/hide <b>[Video Wall]</b> tab from the main menu.
	Copy EDID from this Video Output	Check this box to copy EDID from the monitor when booting ( <b>only for unicast mode</b> ). Default setting is unchecked.
	Maximum bit rate (for transmitter only)	Select an appropriate bitrate according to your network bandwidth. (Options: <b>Best Effect/300 Mbps/150 Mbps/100 Mbps/50 Mbps/10 Mbps</b> )
	Scaler Output Mode (for receiver only)	Options: <b>Pass-Through/Auto Detect (Per EDID)/Full HD 1080p60/Full HD 1080p50/Ultra HD 2160p30/Ultra HD 2160p25/Ultra HD 2160p24/Customize.</b>
	Timeout for detecting video lost (for receiver only)	Select the detection duration of video lost (Options: <b>3s/5s/10s/20s/30s/60s/Never</b> ) or check the " <b>Turn off screen on video lost</b> " box to disable the video-lost detection.
<b>USB over IP</b>	Enable USB over IP	Check/uncheck this box to enable/disable USB transmission over IP.
	Operation Mode	<p>Select a preferred USB operation mode when connecting to a USB device.</p> <ul style="list-style-type: none"> <li>● <b>Auto select mode:</b> Select this option to automatically apply a corresponding USB operation mode according to the detected extender operation mode. This works the same as checking the "<b>Auto select USB operation mode per casting mode</b>" box in the <b>[Network]</b> tab.</li> <li>● <b>Active on link:</b> Select this option if your extender operation mode is set as "Extender".</li> <li>● <b>Active per request:</b> Select this option if your extender operation mode is set as "Matrix".</li> </ul>
	Compatibility Mode	<ul style="list-style-type: none"> <li>● <b>Mouse not responding well</b> (for transmitter only): Check this box if the USB mouse responding is slow and queer.</li> <li>● <b>K/M over IP:</b> Uncheck this box if the keyboard, mouse, touch panel don't work as expected. By default, this box is checked.</li> </ul>
<b>Serial over IP</b>	Enable Serial over IP	Check/uncheck this box to enable/disable RS-232 data transmission over IP.
	Operation Mode	<ul style="list-style-type: none"> <li>● <b>Type 1 mode (Incongruent baud rate):</b> Communicate with different RS-232 devices from host device through RS-232 port (Normally the host device is a PC). The communication baud rate (A) between the host PC and the transmitter can be unequal to the communication baud rate (B) between the receiver and the RS-232 device. The communication baud rate (C) of the network switch can also be unequal to (A) and (B).</li> <li>● <b>Type 2 mode (Congruent baud rate):</b> Communicate with many RS-232 devices from host device through RS-232 port (Normally the host device is a PC). The communication baud rate (A) between the host PC and the transmitter is equal to the communication baud rate (B) between the receiver and the RS-232 device and the communication baud rate (C) of the network switch. *Type 2 mode is the recommended mode for serial transmission over IP.</li> <li>● <b>Type 1 guest mode: (Don't use this mode)</b></li> <li>● <b>Type 2 guest mode:</b> We recommend you contact our local distributor for technical support.</li> </ul>
	Baud rate Setting for Type 2	Set up baud rate settings for Type 2 operation mode.

Table 8-5 Option Introduction of **[Functions]** Tab



**Type 1 mode: Baudrate A ≠ Baudrate B ≠ Intermediate Baudrate C**

Figure 8-15 Type 1 Configuration of Serial Communication



**Type 2 mode: Baudrate A = Baudrate B = Intermediate Baudrate C**

Figure 8-16 Type 2 Configuration of Serial Communication

## Chapter 9 Technical Support

Please contact your local distributors for more information or technical support

## Chapter 10 FCC/CE Statements

**FCC Statement:** This equipment has been tested and found to comply with the regulations for a Class B digital device, pursuant to Part 15 of the FCC Rules. These limits are designed to provide reasonable protection against harmful interference when the equipment is operated in a commercial environment. This equipment generates, uses, and can radiate radio frequency energy and, if not installed and used in accordance with this User Guide, may cause harmful interference to radio communications. Operation of this equipment in a residential area is likely to cause harmful interference in which case, the user will be required to correct the interference at his/her own expense.

**CE Statement:** This is a Class B product in a domestic environment, this product may cause radio interference, in which case the user may be required to take adequate measures.

## Chapter 9 Technical Support

Please contact your local distributors for more information or technical support



The manual contents are subject to change without prior notice.

© Copyright 2024. All Rights Reserved.





**Vertiv.com**

© 2025 Vertiv Group Corp. All rights reserved. Vertiv™ and the Vertiv logo are trademarks or registered trademarks of Vertiv Group Corp. All other names and logos referred to are trade names, trademarks or registered trademarks of their respective owners. While every precaution has been taken to ensure accuracy and completeness here, Vertiv Group Corp. assumes no responsibility, and disclaims all liability, for damages resulting from use of this information or for any errors or omissions. Specifications, rebates and other promotional offers are subject to change at Vertiv's sole discretion upon notice.

Vertiv™ Avocent® VHX131L | VHX231L\_UM\_EN\_AP (R01/020425)