

# Battery Disconnect Testing: Interrupting and Arc Flash Results at 60KA, 98VDC

**Mike Morroni**  
**Senior Design Electrical Engineer**  
**Electric Equipment & Engineering Co.**  
**Denver, CO 80216**

## Introduction

DC short circuit tests per the UL 489<sup>[1]</sup> standard were performed on four battery disconnects rated 200 through 2400 amp. UL 489 is the standard for Molded-Case Circuit Breakers, Molded-Case Switches and Circuit Breaker enclosures. In regards to short circuits, UL 489 is concerned with the maximum interrupting levels obtained and the integrity of the switch or breaker after the completion of the tests. UL 489 does not concern itself with peak let-through currents, clearing times or incident energy. However, while performing these short circuit tests, additional data acquisition was employed to capture peak let-through currents, clearing times and incident energy. These data points are relevant to arc flash calculations. This paper presents those results and compares them to theoretical calculations. The test conditions and their relevance to the test results will be explored.

## Short Circuit Tests – UL 489

UL 489 requires two short circuit tests; a withstand test (O) and a closing test (CO). The withstand test is conducted with the breaker closed when the short circuit is applied. The closing test is performed with the breaker open and is remotely closed into the short circuit. UL489 allows the manufacturer to determine the test current level. Under UL 489 these short circuit tests are considered successful when:

- The protective device interrupts the desired current
- There is no visible physical damage
- After tripping, the protective device can be reclosed
- A 30 amp non-time delay fuse between source and ground does not blow
- A hipot test shows no insulation breakdown

## Test Samples

The molded case devices tested have two possible types of protective trips; overload and instantaneous. The difference between molded case switches and breakers is as follows:

- Molded Case Switches – Instantaneous (magnetic) trip only
- Molded Case Breakers – Overload (thermal) and Instantaneous (magnetic) trips

A thermal trip is used for overload protection and consists of a bi-metallic element that expands with temperature over time. If the ampere rating of the breaker is exceeded, the element heats, continues to expand until it mechanically operates an internal trip lever and opens the breaker.

In the event of a short circuit, it is desirable to interrupt the current instantaneously. Conductors that carry current have a magnetic field encircling the conductor. Under short circuit conditions, the magnetic field is significantly greater. Under short circuit currents, a magnetic trip coil internal to the disconnect is energized and “instantaneously” operates an internal trip lever to open the disconnect. Assuming the disconnect can clear the fault, the higher the short circuit current, the faster the magnetic trip coil operates. Thus clearing times will be reduced at higher short circuit currents. These tests were conducted using the molded case switches.

## Test Circuit

The tested disconnects are used primarily in 48VDC, VRLA telecom applications. A review of the major battery manufacturers reveals the highest available battery short circuit current at the battery terminals is 43.8kA. For this reason, a test level of 60kA DC was selected to cover present and future battery short circuit levels.

Tests were performed at the Rockwell high current test lab in Milwaukee. This lab utilizes a three phase, 500 MVA AC generator coupled to a three phase DC bridge. In order to deliver the desired 60kA DC current, pre-short circuit calibration tests showed it was necessary to raise the open circuit output voltage to 98 VDC.

## Test Connections

Typical DC UL 489 circuit breaker applications interrupt both the (+) and (-) polarities as shown in Figure 1. This is the typical connection diagram utilized when circuit breaker manufacturers obtain their maximum DC short circuit ratings.

In 48 VDC telecommunications applications, one polarity of the battery is grounded. It is not necessary to switch both polarities. The UL 489 tests described in this paper were performed with the disconnect connected as shown in Figure 2, switching only the ungrounded polarity.

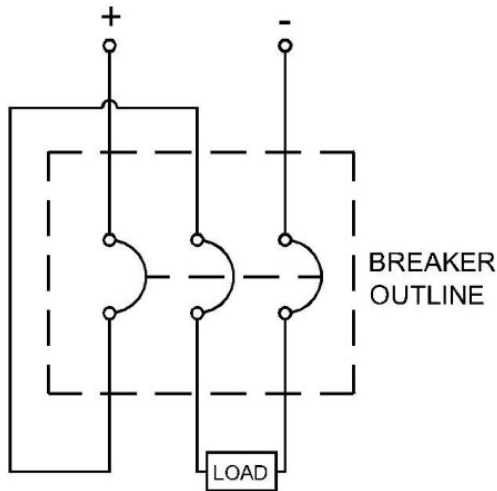

Figure 1. Typical DC Breaker Wiring

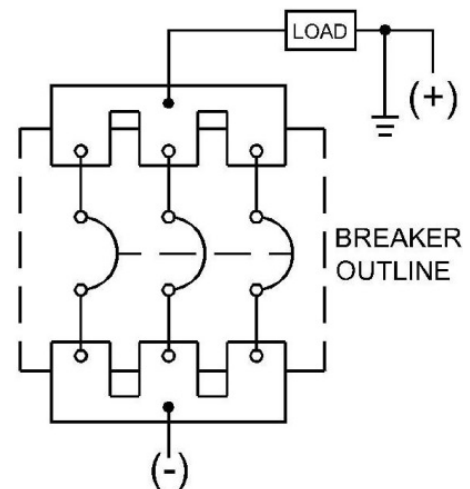

Figure 2. Connections As Tested

### Disconnect Location and Short Circuit Protection - Two Possible Locations

A disconnect utilizing the connection diagram shown in Figure 1 requires remote mounting from the battery terminals. A short circuit between the battery and the remotely mounted disconnect would thus not be protected.

By comparison, utilizing the connection diagram shown in Figure 2, the disconnect can mount on the VRLA battery and connect directly to the negative terminal (Figure 3). In this case, both the connected equipment and the entire cable run have short circuit protection.



**Figure 3. Disconnect Terminated on Negative Pole**

### Arc Flash Test

Arc flash tests are generally conducted on a piece of equipment by shorting the source to ground with a specific wire size to determine how much energy is produced before the upstream protective device clears the fault. The battery disconnect is the upstream protective device. For these tests, arc flash measurements were obtained directly in front of the disconnect. The tested disconnects, when interrupting a short circuit, discharge the heated arcing gases vertically out the top of the device. For these tests, the surface of the arc flash measuring device was positioned 3 inches from the front face of the disconnect (Figure 4). The measuring device was positioned vertically between the handle and the top edge of the disconnect to capture the radiant energy at the handle and the discharge area. Information on test equipment used is provided after the Bibliography at the end of this paper.

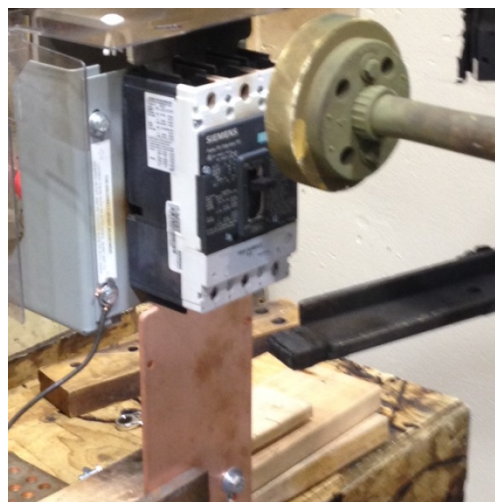

**Figure 4. Arc Flash Test Set-Up**

### Sample Test Data

The test data captured during the withstand (O) short circuit test on a 1200 amp disconnect is shown in Figure 5. This data plot displays the pre-test parameters; system voltage 98 VDC and available short circuit current 60.6 kA DC. Data captured during the laboratory tests record the peak short circuit current and the time required to clear the short circuit. Similar curves were captured for all 4 disconnect frames sizes for both withstand and closing tests.

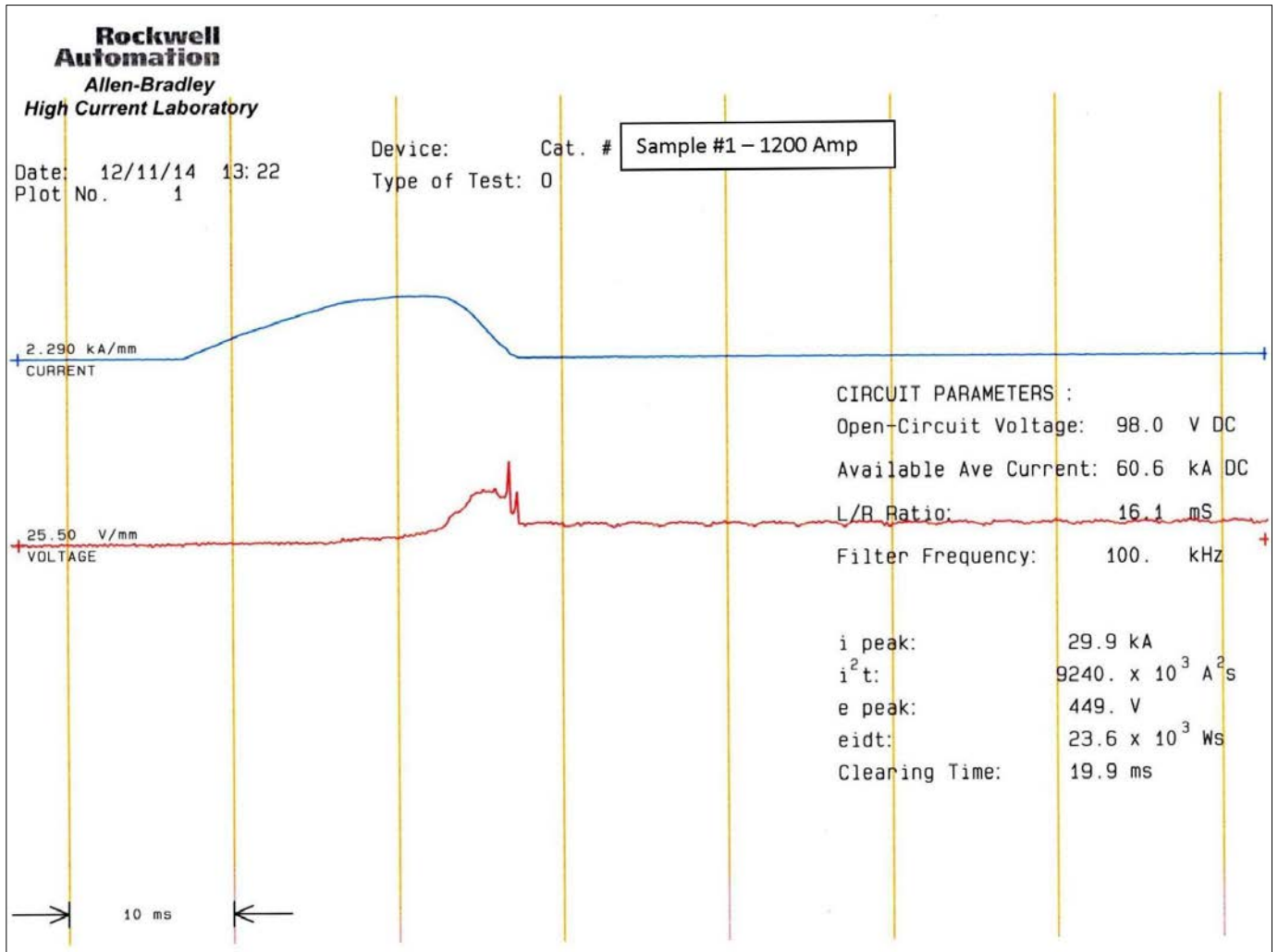

Figure 5. Short Circuit Curve (1200 Amp Sample)

## Arc Flash Calculations

Arc flash data was captured independently and is summarized in Table 1 for each sample tested. The test sample associated with Figure 5 is outlined in red in Table 1. The table compares the test results to the theoretical formulas given in NFPA 70E<sup>[2]</sup> as outlined below.

NFPA 70E 2012 Edition, Annex D provides two formulas for calculating DC arc flash:

$$\text{Formula \# (1) } IE_m = 0.01 \times V_{\text{sys}} \times I_{\text{arc}} \times T_{\text{arc}} / D^2$$

$$\text{Formula \# (2) } I_{\text{arc}} = 0.5 \times I_{\text{bf}}$$

Where:

- $IE_m$  – Arc Flash Energy at maximum power point (cal/cm<sup>2</sup>)
- $V_{\text{sys}}$  – System Voltage (volts)
- $I_{\text{arc}}$  – Arcing current (amperes)
- $I_{\text{bf}}$  – Bolted fault current (amperes)
- $T_{\text{arc}}$  – Total arcing time (seconds)
- $D$  – Working distance from the arc (cm)

From the data acquired in Figure 5:

$$I_{\text{arc}} = i_{\text{peak}} \text{ (peak let-through current)} = 29,900 \text{ amps}$$

$$T_{\text{arc}} = \text{Clearing Time} = 19.9 \text{ msec}$$

Using the distance to the arc flash measurement surface as shown in Figure 4:

$$D = 3 \text{ inches (7.62 cm)}$$

Formula # (1) becomes:

$$IE_m = 0.01 \times V_{\text{sys}} \times I_{\text{arc}} \times T_{\text{arc}} / D^2 \quad IE_m = 0.01 \times (98) \times (29900) \times (0.0199) / (7.62)^2 = \underline{10.04 \text{ cal/cm}^2}$$

By comparison, applying Formula (1) when ***no protective device is present***, the following values are used:

$$I_{\text{arc}} = 0.5 \times I_{\text{bf}} \quad I_{\text{arc}} = 0.5 \times 60,000 = 30,000$$

$$T_{\text{arc}} = 2 \text{ seconds (the estimated time for the arc to burn out or personnel to back away)}$$

$$D = 18 \text{ inches (45.72 cm)} \text{ – Estimated distance to the chest of working personnel}$$

$$\text{This yields: } IE_m = 0.01 \times V_{\text{sys}} \times I_{\text{arc}} \times T_{\text{arc}} / D^2 \quad IE_m = 0.01 \times (98) \times (30,000) \times (2) / (45.72)^2 = \underline{28.13 \text{ cal/cm}^2}$$

## Test Results

**Table 1. Comparison of Theoretical and Actual Test Data**

Laboratory Captured Test Data							NFPA 70E Calculations		
Open Circuit Voltage:		$V_{sys}$	98.0 V DC				Based On Test Data with D = 3" *	Based On Test Data with D = 18" **	Assumes No Protective Device with D = 18" ***
Available Short Circuit Current:		$I_{bf}$	60.6 kA DC						
Working Distance:		D	3" (7.62 cm)						
Open Air		Peak Let-Through		% of $I_{bf}$	$I^2t$	Clearing Time	Measured Incident Energy		
Disconnect Size	UL 489 Test	$I_{arc}$ (KA)			$A^2S$	$T_{arc}$ (msec)	$IE_m$ (Cal/cm <sup>2</sup> )		
200 - 750 Amp	Closing	21.7	36%	2840 k	17.7	0.0275	6.48	0.180	28.13
	Withstand	23.7	39%	3290 k	17.6	0.0344	7.04	0.196	28.13
800 - 1200 Amp	Closing	28.6	47%	6570 k	17.2	0.0146	8.3	0.231	28.13
	Withstand	29.9	49%	9240 k	19.9	0.0148	10.04	0.279	28.13
1350 - 1800 Amp	Closing	32.1	53%	9030 k	19.4	0.0262	10.51	0.292	28.13
	Withstand	31.5	52%	10000 k	20.6	0.0498	10.95	0.304	28.13
2100 - 2400 Amp	Closing	35.6	59%	21900 k	32.6	0.0347	19.59	0.544	28.13
	Withstand	39.7	66%	26200 k	31	0.027	20.77	0.578	28.13
Average		30.4	50%		22.0	0.029			
DC Arc Flash Calculations Annex D - D.8.1.1			$IE_m = 0.01 \times V_{sys} \times I_{arc} \times T_{arc} / D^2$			$I_{arc} = 0.5 \times I_{bf}$			
* Use Formula with test result data for clearing time ( $T_{arc}$ ) and peak let through current ( $I_{arc}$ ). Test distance, D = 3 in. (7.62 cm)									
** Use Formula with test result data for clearing time ( $T_{arc}$ ) and peak let through current ( $I_{arc}$ ). Test distance, D = 18 in. (45.72 cm)									
*** Use Formula as if no protective device. $I_{arc} = 0.5 \times I_{bf} = 30,000$ , $T_{arc} = 2$ seconds, D = 18 in (45.72 cm).									

## Observations from Test Results

- With a protective disconnect in the circuit, measured incident energy was significantly less than the calculated value.
- From Formula (1) the incident energy decreases by the square of the distance. Test results were measured at 3". This should make the laboratory test results 36 times more severe than at the default distance of 18".
- With these disconnects in the circuit, test data shows on average  $I_{arc} = 50\%$  of the  $I_{bf}$ , and thus validates Formula (2). Note the range was 36-66%
- The resulting incident energy measurements (3" in front of the disconnect handle) were well below the 1.2 cal/cm<sup>2</sup> threshold (usually calculated at 18") that distinguishes where PPE equipment is required. Visual observations during the tests report discharge gas/sparks venting an estimated 6 feet above the disconnect rather than in front of the handle.

**Additional Test Performed – Disconnects with 50mV Shunts**

Short circuit tests (withstand and closing) were also performed on a 600 and a 1200 amp disconnect each with an integral 50mV metering shunt (Figure 6). Over these four tests, the increased impedance of the shunt raised the let-through short circuit current an average of 1kA and decreased the clearing time an average of 1.9 msec. The physical and electrical properties of the shunts were not affected.



**Figure 6. Disconnect with Integrated Metering Shunt**

**Additional Test Performed – “Breaker in a Box”**

Short circuit tests were performed on a 1200 amp disconnect in a NEMA1 enclosure (Figure 7). The enclosure size (42” x 16” x 8”) was based on NEC<sup>[3]</sup> maximum wire bending space requirements. One test was performed with the door closed , another with the door open (Table 2). With the disconnect mounted as shown, the arc flash energy was consistent with the open air test.

Open Circuit Voltage:  $V_{sys}$  98.0 V DC  
 Available Ave. Current:  $I_{bf}$  60.6 kA DC  
 Working Distance: D 3" (7.62 cm)

NEMA 1 Enclosure	UL 489 Test	Peak Let-Through $I_{arc}$ (KA)	Clearing Time $T_{arc}$ (msec)	Measured
				Incident Energy $IE_m$ (Cal/cm <sup>2</sup> )
1200 Amp - Door Closed	Closing	27.7	16.6	0.0042
	Withstand	30.6	19.8	0.0057
1200 Amp - Door Open	Closing	27.8	17	0.0078
	Withstand	31	19.3	0.0131

**Table 2. Arc Flash Data in an Enclosure**



**Figure 7. 1200 Amp Enclosure**

## Inherent Design Characteristics of Test Samples

The family of disconnects used for these tests were molded case switches and molded case breakers with internal arc chutes. When a circuit carrying current is interrupted, an arc is generated. As the contact surfaces separate, a conductive heated gas is produced (arc) that attempts to bridge the gap between the two contact surfaces. Arc chutes are a series of plates that are used to extinguish the arc as the contacts separate (Figure 8). The gas is vented upward and escapes the molded case device out the top (Figure 9).



Figure 8. Arc Chute



Figure 9. Arcing Vents

## Conclusions

Selecting the battery disconnect location can have a strategic effect on system protection for both short circuit and arc flash events. Connecting the disconnect directly to the battery terminal post more effectively protects equipment downstream.

Test results demonstrate that insertion of these protective battery disconnects into a 98 V, 60 kA DC circuit will limit the incident energy at the disconnect to well under 1.2 cal/cm<sup>2</sup>. The incident energy measured test results were considerably less when compared to NFPA 70E theoretical calculations.

Test conditions should be taken into account before applying these results in practical applications:

- Atypical circuit connections (Figure 2) utilize the entire capacity of the disconnect to interrupt one polarity of the battery.
- Disconnect construction varies by manufacturer. Interrupting capacity, magnetic trip time and the method used to vent the arc flash energy were integral to the results obtained.
- Disconnect construction that utilize arc chutes and proper venting technologies are necessary to limit the incident energy at the front face of the disconnect.
- The 60 kA DC available short circuit test current is much greater than the typical 48V DC, VRLA telecommunications application which may be 10 kA or less. The internal magnetic trip coil used to open the disconnect does not have a linear clearing time vs. short circuit characteristic. Clearing times at 10 kA could be significantly longer, while the current much less ( $I_{arc} = 5000$ ). Additional testing at lower levels is therefore needed.



## References

1. UL 489 Standard for Safety Molded-Case Circuit Breakers, Molded Case Switches and Circuit Breaker Enclosures, 2013
2. NFPA 70E Standard for Electrical Safety in the Workplace, 2012: Quincy, MA.
3. NFPA 70 National Electrical Code 2014: Quincy, MA

## Bibliography

1. Cantor, William, "DC Arc Flash. The Implications of NFPA 70E 2012 On Battery Maintenance," proceedings from 2012 Battcon conference.
2. Doan, Daniel R., "Arc Flash Calculations for Exposures to DC Systems"

## Acknowledgments

Robert Kerr – Rockwell Automation, Technologist, Test & Certification Laboratories

John D. Hubbard – Rockwell Automation, Engineer, Product Performance Testing

## Arc Flash Test Equipment

Arc flash measurements were performed by Rockwell lab technicians. The copper slug used for measurement is manufactured by KAS Technical for use in arc flash testing as described in IEEE 1584. The slug itself is an 18 gram copper disc, 4cm in diameter and 1.6mm thick with a Type J thermocouple embedded at its center. Connected to the calorimeter's output via a miniature thermocouple connector was a Dewetron isolated input module model DAQP-THERM, serial number 373940, mounted in slot 7 of a Dewetron mainframe model DEWE-50-USB2-8, serial number 53110454, which was sampling at 5,000 samples per second. The data files were recorded from the hardware using Dewesoft 7.0.6 software.